

# DocuPrint CP305 d



## User Guide

# Contents

1	Specifications.....	27
2	Basic Operation .....	31
	Main Components .....	32
	Front View.....	33
	Rear View .....	34
	Operator Panel .....	35
	Securing the Printer .....	36
	Preparing Printer Hardware.....	37
	Installing Optional Accessories.....	38
	Installing the Optional Memory Module .....	39
	Installing the Optional 250-Sheet Feeder .....	42
	Turning on the Printer.....	46
	Printing a Panel Settings Page.....	47
	Power Saver Mode.....	48
	Exiting the Power Saver Mode .....	49
3	Printer Management Software .....	51
	Print Drivers.....	52
	CentreWare Internet Services .....	53
	Creating an Administrative Password .....	54
	SimpleMonitor (Windows Only) .....	55
	Setup Disk Creation Tool (Windows Only) .....	56
4	Network Basics .....	57
	Overview of Network Setup and Configuration.....	58
	Connecting Your Printer .....	59
	Connecting Printer to Computer or Network.....	60
	Setting the IP Address.....	63
	TCP/IP and IP Addresses.....	64
	Automatically Setting the Printer's IP Address .....	65
	Dynamic Methods of Setting the Printer's IP Address .....	66
	Assigning an IP Address (for IPv4 Mode).....	67
	Verifying the IP Settings .....	69
	Printing and Checking the Printer Settings Page.....	70
	Installing Print Driver on Computers Running Windows.....	71
	Identifying Print Driver Pre-install Status (For Network Connection Setup).....	72
	Inserting the CD-ROM .....	73
	USB Connection Setup.....	74
	Network Connection Setup .....	75

	Setting Up for Shared Printing .....	76
	Installing Print Driver on Computers Running Mac OS X .....	81
	Installing Print Driver on Computers Running Linux (CUPS) .....	82
	Installing the Print Driver.....	83
	Setting Up the Queue .....	84
	Setting the Default Queue .....	87
	Specifying the Printing Options.....	88
	Setting the Password for Authority as the Printer Administrator.....	90
	Uninstalling the Print Driver .....	91
<b>5</b>	<b>Printing Basics .....</b>	<b>93</b>
	About Print Media .....	94
	Print Media Usage Guidelines .....	95
	Print Media That Can Damage Your Printer .....	96
	Print Media Storage Guidelines .....	97
	Supported Print Media .....	98
	Print Media Dimensions.....	99
	Usable Print Media .....	100
	Loading Print Media.....	103
	Capacity.....	104
	Loading Print Media in the Standard 250-Sheet Tray and the Optional 250-Sheet Feeder .....	105
	Loading Print Media in the Single Sheet Feeder (SSF).....	110
	Setting Paper Sizes and Types .....	114
	Setting Paper Sizes .....	115
	Setting Paper Types .....	116
	Printing .....	117
	Sending a Job to Print .....	118
	Canceling a Print Job.....	119
	Using the Stored Print Function.....	120
	Printing PDF Files Using PDF Bridge (Windows Only).....	122
	Duplex Printing .....	124
	Selecting Printing Options .....	126
	Printing Custom Size Paper.....	132
	Auditron .....	134
	Checking Status of Print Data.....	135
	Printing a Report Page .....	136
	Printer Settings .....	137
	Printing With Web Services on Devices (WSD) .....	138
	Adding Roles of Print Services .....	139
	Printer Setup.....	140
<b>6</b>	<b>Using the Operator Panel Menus .....</b>	<b>141</b>
	Understanding the Printer Menus.....	142
	Report/List .....	143

	Meter Readings .....	145
	Admin Menu.....	146
	Tray Settings.....	169
	Panel Lock Function.....	173
	Enabling the Panel Lock .....	174
	Disabling the Panel Lock .....	175
	Setting the Power Saver Time Option .....	176
	Resetting to Factory Defaults .....	177
<b>7</b>	<b>Troubleshooting .....</b>	<b>179</b>
	Clearing Jams.....	180
	Avoiding Jams .....	181
	Identifying the Location of Paper Jams.....	182
	Clearing Paper Jams From the SSF.....	183
	Clearing Paper Jams From the Standard 250-Sheet Tray .....	186
	Clearing Paper Jams From the Fuser Unit .....	189
	Clearing Paper Jams From the Duplexer .....	191
	Clearing Paper Jams From the Optional 250-Sheet Feeder .....	192
	Jam Problems.....	195
	Basic Printer Problems .....	199
	Display Problems.....	200
	Printing Problems .....	201
	Print Quality Problems.....	203
	The Output Is Too Light.....	204
	Toner Smears or Print Comes Off .....	206
	Random Spots/Blurred Images.....	207
	The Entire Output Is Blank.....	208
	Streaks Appear on the Output .....	210
	Part or the Entire Output Is Black .....	211
	Pitched Color Dots.....	212
	Vertical Blanks .....	213
	Mottle .....	214
	Ghosting .....	215
	Light-Induced Fatigue .....	216
	Fog.....	217
	Bead-Carry-Out (BCO) .....	218
	Jagged Characters .....	219
	Banding.....	220
	Auger Mark .....	221
	Wrinkled/Stained Paper .....	222
	Damage on the Leading Edge of Paper .....	223
	The Top and Side Margins Are Incorrect.....	224
	Color Registration Is out of Alignment .....	225
	Protrudent/Bumpy Paper .....	226
	Adjusting Color Registration .....	227
	Performing Auto Adjust.....	228



	Printing the Color Registration Chart .....	229
	Determining Values .....	230
	Entering Values .....	231
	Problems With Installed Optional Accessories .....	233
	Other Problems .....	234
	Understanding Printer Messages .....	235
	Contacting Service .....	238
	Getting Help.....	239
	LCD Panel Messages .....	240
	SimpleMonitor Alerts.....	241
	Obtaining the Product Information .....	242
	Non-Genuine Mode .....	243
<b>8</b>	<b>Maintenance .....</b>	<b>245</b>
	Cleaning the Printer.....	246
	Cleaning Inside the Printer .....	247
	Cleaning the Color Toner Density (CTD) Sensor .....	250
	Replacing Toner Cartridges.....	252
	Overview .....	253
	Removing the Toner Cartridges.....	254
	Installing a Toner Cartridge .....	255
	Replacing the Drum Cartridge .....	257
	Removing the Drum Cartridge .....	258
	Installing the Drum Cartridge .....	260
	Replacing the Fuser Unit.....	263
	Removing the Fuser Unit.....	264
	Installing the Fuser Unit.....	266
	Resetting the Counter of the Fuser Unit .....	268
	Replacing the Feed Roller Unit.....	269
	Removing the Feed Roller Unit in the Standard 250-Sheet Tray ..	270
	Installing the Feed Roller Unit in the Standard 250-Sheet Tray ...	271
	Ordering Supplies.....	272
	Consumables.....	273
	When to Order Supplies .....	274
	Recycling Supplies .....	275
	Storing Print Media.....	276
	Storing Consumables .....	277
	Managing the Printer .....	278
	Checking or Managing the Printer with CentreWare Internet Services .....	279
	Checking Printer Status with SimpleMonitor (Windows Only) .....	280
	Conserving Supplies.....	281
	Checking Page Counts.....	282
	Moving the Printer .....	283
	Removing Options .....	285
	Removing the Optional Memory Module .....	286

Removing the Optional 250-Sheet Feeder .....	288
Contacting Fuji Xerox .....	291
Technical Support.....	292
Online Services .....	293



# Preface

---

Thank you for purchasing the DocuPrint CP305 d.

This guide is intended for users who use the printer for the first time, and provides all the necessary operating information about the printer function.

Please read this guide to achieve the best performance from this printer.

This guide assumes you are familiar with computers and the basics of network operation and configuration.

After reading this guide, keep it safe and handy for future reference.

DocuPrint CP305 d User Guide Help

Copyright© 2011 by Fuji Xerox Co., Ltd.

Fuji Xerox Co., Ltd.

January 2011 (Edition 1)

ME5055E2-1

# Trademarks and Document Disclaimer

---

Apple®, Bonjour®, ColorSync®, Macintosh®, and Mac OS® are trademarks of Apple Inc. in the United States and/or other countries.

PCL® is a trademark of Hewlett-Packard Corporation in the United States and/or other countries.

Microsoft®, Windows Vista®, Windows®, and Windows Server® are trademarks of Microsoft Corporation in the United States and/or other countries.

Linux is a registered trademark of Linus Torvalds.

Novell is a registered trademark and SUSE is a trademark of Novell, Inc. in the United States and other countries.

Red Hat and Red Hat Enterprise Linux are registered trademarks of Red Hat, Inc. in the U.S. and other countries.

All product/brand names are trademarks or registered trademarks of the respective holders.

In this manual, safety instructions are preceded by the symbol . Always read and follow the instructions before performing the required procedures.

It may be a legal offence to print currency notes, certificates of stocks and securities, or any other documents of similar nature, regardless of whether they will be used.

Fuji Xerox is not responsible for any breakdown of machines due to infection of computer virus or computer hacking.

## **IMPORTANT:**

1. This manual is copyrighted with all rights reserved. Under the copyright laws, this manual may not be copied or modified in whole or part, without the written consent of the publisher.
2. Parts of this manual are subject to change without prior notice.
3. We welcome any comments on ambiguities, errors, omissions, or missing pages.
4. Never attempt any procedure on the machine that is not specifically described in this manual. Unauthorized operation can cause faults or accidents. Fuji Xerox is not liable for any problems resulting from unauthorized operation of the equipment.
5. Decompiling this manual is prohibited.

An export of this product is strictly controlled in accordance with Laws concerning Foreign Exchange and Foreign Trade of Japan and/or the export control regulations of the United States.

XEROX, the sphere of connectivity design, and DocuPrint are trademarks or registered trademarks of Xerox Corporation in the U.S. or Fuji Xerox Co., Ltd.

All Xerox and Fuji Xerox product names are either registered trademarks or trademarks of Xerox Corporation or Fuji Xerox Co., Ltd.

# About License

---

## **RSA BSAFE**

RSA BSAFE software, produced by RSA Security Inc., has been installed on this printer.



## **DES**

This product includes software developed by Eric Young.

(eay@mincom.oz.au)

## **AES**

Copyright© 2003, Dr BrianGladman, Worcester, UK. All rights reserved. This product uses published AES software provided by Dr Brian Gladman under BSD licensing terms.

## **TIFF(libtiff)**

LibTIFFCopyright© 1988-1997 SamLeffler

Copyright© 1991-1997 Silicon Graphics, Inc.

## **ICC Profile (Little cms)**

LittlecmsCopyright© 1998-2004 Marti Maria

## **JPEG**

Our printer software uses some of the codes defined by the Independent JPEG Group.

# Types of Manuals

---

## Manuals included with the printer

The following manuals are provided with the DocuPrint CP305 d.

Safety Guide	Describes the information you need to know before using the printer and to operate the printer safely.
Setup Guide	Provides step-by-step instructions on how to set up your printer.
User Guide (CHM Help for Windows/HTML files for Mac OS X)	Describes how to get ready to print and set various features. It also covers the operator panel menus, troubleshooting tips, and maintenance information. This guide is on the <i>Driver CD Kit</i> .
PostScript® User Guide	Describes how to set up your printer as a PostScript® printer and the features that can be configured on your print driver. This guide is on the <i>PostScript Driver Library CD</i> .

## Manuals included with an optional accessory

The following manual is provided with the optional accessories (sold separately).

Installation Guide	Optional accessories that require an installation at the customer's site are provided with an Installation Guide.
--------------------	---

# Using This Guide

---

This section includes:

- ["Organization" on page 12](#)
- ["Conventions" on page 13](#)



## ■ Organization

This guide is organized into the following chapters. The summary of each chapter is as follows:

<a href="#">1 Specifications</a>	Describes the printer specifications.
<a href="#">2 Basic Operation</a>	Describes the main components of the printer, the power saver mode, and the preparation of the printer to use.
<a href="#">3 Printer Management Software</a>	Describes the software available for the printer.
<a href="#">4 Network Basics</a>	Describes the basic information about how to connect the printer to your computer via the network or USB and how to install the print driver.
<a href="#">5 Printing Basics</a>	Describes the supported paper, how to load paper, and how to print data using various print features.
<a href="#">6 Using the Operator Panel Menus</a>	Describes the setting items available on the operator panel, and their setup procedures.
<a href="#">7 Troubleshooting</a>	Describes the troubleshooting tips for printer problems such as paper jams.
<a href="#">8 Maintenance</a>	Describes how to clean the printer, how to replace consumables, and how to see the printer status.
<a href="#">9 Contacting Fuji Xerox</a>	Describes support information.

## ■ Conventions

**1** In this guide, personal computers and workstations are collectively called “computers”.

**2** The following terms are used throughout this guide:

### **IMPORTANT:**

- Important information that must be read and followed.

### **NOTE:**

- Additional information that merits emphasis.

### **See also:**

- References within this guide.

# Safety Notes























Before using this product, read "Safety Notes" carefully for safety use.

This product and recommended supplies have been tested and found to comply with strict safety requirements including safety agency approvals and compliance with environmental standards. Follow the following instructions for safety use.

 **WARNING:**

- Any unauthorized alteration including an addition of new functions or connection to external devices may not be covered by the product warranty. Contact your local Fuji Xerox representative for more information.

Follow all warning instructions marked on this product. The warning marks stand for the followings:

 <b>DANGER</b>	Used for item that if not followed strictly, can lead death or severe or fatal injuries and the possibility to do it is comparatively high.					
 <b>WARNING</b>	Used for items that if not followed strictly, can lead to severe or fatal injuries.					
 <b>CAUTION</b>	Used for items that if not followed strictly, can cause injuries to user or damages to machine.					
 : A symbol for items to pay attention to when handling machine. Follow instructions carefully to use machine safely.						
 Caution	 Flammable	 Explodable	 Electric shock	 Heated surface	 Moving object	 Pinched fingers
 : A symbol for prohibited items. Follow instructions carefully to avoid any dangerous acts.						
 Prohibited	 No fire	 Do not touch	 Do not use in bathroom	 Do not tear down	 Keep away from wet	 Never touch with wet hand
 : A symbol for items that must be performed. Follow instructions carefully to carry out these essential tasks.						
 Instructions	 Unplug	 Ground/Earth				

# ■ Electrical Safety

## WARNING

This product shall be operated by the power source as indicated on the product's data plate. Consult your local power company to check if your power source meets the requirements.



### WARNING:

- **Connect this product to a protective earth circuit.**

This product is supplied with a plug that has a protective earth pin. The plug fits only into an earthed electrical outlet. This is a safety feature. If the plug doesn't fit to the outlet, contact an electrician to replace the outlet to avoid risk of electric shock. Never use an earthed adapter plug to connect the product to the electrical outlet that has no earth connection terminal.

Improper connection of a grounding conductor may cause electric shock.



Plug the power cord directly into a grounded electrical outlet. To prevent overheat and a fire accident, do not use an extension cord, a multi-plug adaptor or a multiple connector. Consult your local Fuji Xerox representative to check if an outlet is grounded.



Connect this product to a branch circuit or an outlet that has larger capacity than the rated ampere and voltage of this product. See the data plate on the rear panel of this product for its rated ampere and voltage.



Never touch the power cord with wet hands. It may cause electric shock.



Do not place an object on the power cord.



Always keep the plug connection free of dust. The dusty and damp environment may bring about minute electric current in a connector. It may generate heat and eventually cause a fire accident.



To avoid the risk of electric shock and a fire accident, only use the power cord supplied with this product or the ones designated by Fuji Xerox.

The power cord is exclusive use for this product. Do not use it for any other product.

Do not damage or alter the power cord. Damage and alteration may generate heat and eventually cause electric shock or a fire accident.

If the power cord is damaged or insulated wires are exposed, contact your local Fuji Xerox representative for its replacement. Do not use a damaged or uninsulated cord to avoid the risk of electric shock and a fire accident.

---

## CAUTION



When cleaning this product, always switch off and unplug it. Access to a live machine interior may cause electric shock.



When cleaning this product, switch off the product and its switchboard (branch circuit). Access to a live machine interior may cause electric shock.



Do not unplug or re-plug this product with the switch on. Plugging and unplugging a live connector may deform the plug and generate heat, and eventually cause a fire accident.

---



Hold the plug not the cord when unplugging this product, or it may damage the cord and cause electric shock or a fire accident.



Always switch off and unplug the machine when it is not used over weekends or long holidays. It may cause deterioration of insulations and eventually electric shock or a fire accident.



Once a month, switch off this product and check if

- the power cord is plugged firmly into an electrical outlet;
- the plug is not excessively heated, rusted or bent;
- the plug and electrical outlet are free of dust; and
- the power cord is not cracked or worn down.

Once you notice any unusual condition, switch off and unplug this product first and contact your local Fuji Xerox representative.

---

## ■ Machine Installation

### ⚠ WARNING



Do not locate this product where people might step on or trip over the power cord. Friction or excessive pressure may generate heat and eventually cause electric shock or a fire accident.

### ⚠ CAUTION



Never locate this product in the following places:

- Near radiators or any other heat sources
- Near volatile flammable materials such as curtains
- In the hot, humid, dusty or poorly ventilated environment
- In the place receiving direct sunlight
- Near cookers or humidifiers



This product weighs 19.8 kg \*(the main unit with consumables)\*. When moving it, always carry it by a team of two or more persons to avoid mishandling or injury.



Locate this product on a level and sturdy surface that can withstand 19.8 Kg.

Otherwise, if tilted, the product may fall over and cause injuries.



Locate this product in a well-ventilated area. Do not obstruct ventilation openings of the product.

Keep the minimum clearance as follows for ventilation and an access to the power plug. Unplug the product if an abnormal condition is noted.

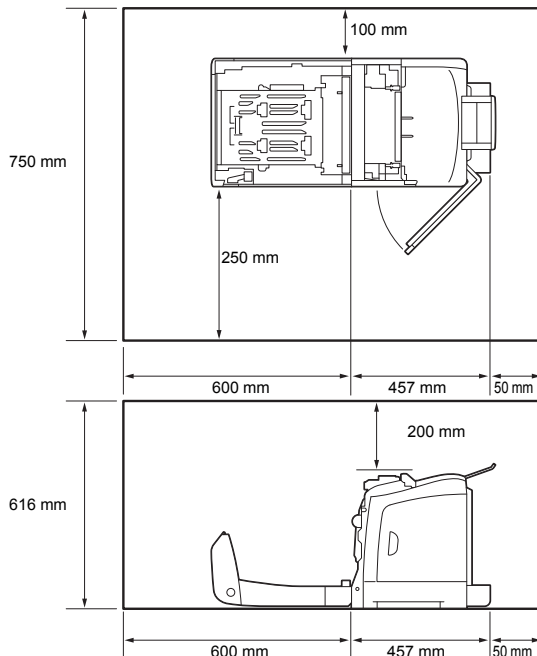



Do not incline the product at more than 10 degree angle. Otherwise, it may fall over and cause injuries.

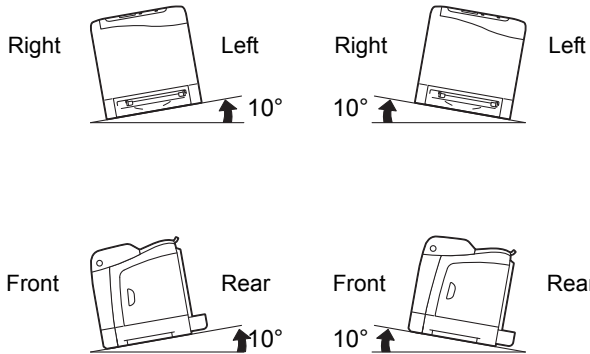

To bundle wires and cables, always use the cable ties and spiral tubes that Fuji Xerox supplies. Otherwise, it may cause some defects.

## ■ Operational Safety

### WARNING



The operator's product maintenance procedures are described in the customer documentation supplied with this product. Do not carry out any other maintenance procedures not described in the documentation.



This product features safety design not to allow operators access to hazard areas. The hazard areas are isolated from operators by covers or protectors which require a tool to remove. To prevent electric shock and injuries, never remove those covers and protectors.



To avoid the risk of electric shock and a fire accident, switch off and unplug the product promptly in the following conditions, then contact your local Fuji Xerox representative.

- The product emits smoke or its surface is unusually hot.
- The product emits unusual noise or odor.
- The power cord is cracked or worn down.
- A circuit breaker, fuse or any other safety device is activated.
- Any liquid is spilled into the product.
- The product is soaked in water.
- Any part of the product is damaged.



Do not insert any object into slots or openings of this product.  
Do not place any of the followings on the product:

- Liquid container such as flower vases or coffee cups
- Metal parts such as staples or clips
- Heavy objects

If liquid is spilled over or metal parts are slipped into the product, it may cause electric shock or a fire accident.



When cleaning this product, use the designated cleaning materials exclusive to it. Other cleaning materials may result in poor performance of the product. Never use aerosol cleaners, or it may catch fire and cause explosion.



Never play the CD-ROM supplied with the product on an audio player. Always use a CD-ROM player. Otherwise, large sound may damage audio players or your ears.



Laser Safety

#### Caution:

- **Any operations or adjustments not stated in the operation manual may cause hazardous light exposure and eventually burn injuries or loss of eyesight.**

This product has been tested and found to comply with the Class 1 Laser Equipment requirements defined by the international standard IEC60825 and has no light exposure hazard. The product has no hazardous light emission as it features light protection components and covers to shut in all light beam during operation and maintenance.

### CAUTION



Always follow all warning instructions marked on or supplied with this product.

To avoid the risk of burn injuries and electric shock, never touch the area with the "High Temperature" or "High Voltage" marks on.



Ventilate well during extended operation or mass copying. It may affect the office air environment due to odor such as ozone in a poorly ventilated room. Provide proper ventilation to ensure the comfortable and safe environment.



## ■ Consumable

### WARNING



---

Store all consumables in accordance with the instructions given on its package or container.



---

Use a broom or a wet cloth to wipe off spilled toner. Never use a vacuum cleaner for the spills. It may catch fire by electric sparks inside the vacuum cleaner and cause explosion. If you spill a large volume of toner, contact your local Fuji Xerox representative.



---

Never throw a toner cartridge into an open flame. Remaining toner in the cartridge may catch fire and cause burn injuries or explosion.

If you have a used toner cartridge no longer needed, contact your local Fuji Xerox representative for its disposal.

---

### CAUTION



---

Keep drum cartridge and toner cartridges out of the reach of children. If a child accidentally swallows toner, spit it out, rinse mouth with water, drink water and consult a physician immediately.



---

When replacing drum cartridge and toner cartridges, be careful not to spill the toner. In case of any toner spills, avoid contact with clothes, skin, eyes and mouth as well as inhalation.



---

If toner spills onto your skin or clothing, wash it off with soap and water.

If you get toner particles in your eyes, wash it out with plenty of water for at least 15 minutes until irritation is gone. Consult a physician if necessary.

If you inhale toner particles, move to a fresh air location and rinse your mouth with water.

If you swallow toner, spit it out, rinse your mouth with water, drink plenty of water and consult a physician immediately.

---

## ■ Warning and Caution Labels

Be sure to follow the warning and caution labels placed on the machine. Do not touch areas with labels indicating high voltage or temperature. This can cause an electric shock or burn.

### CAUTION:

- Always follow all warning instructions marked on or supplied with this product. To avoid the risk of burn injuries and electric shock, never touch the area with the "High Temperature" or "High Voltage" marks on.

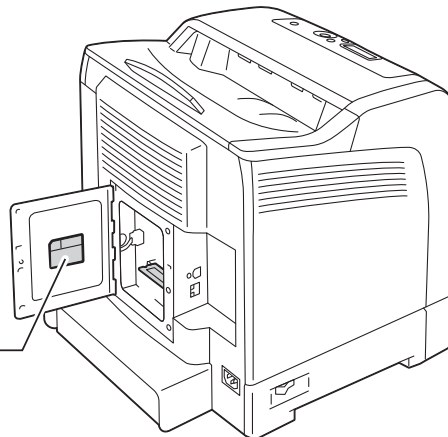
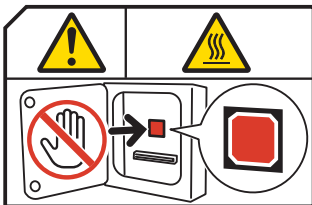
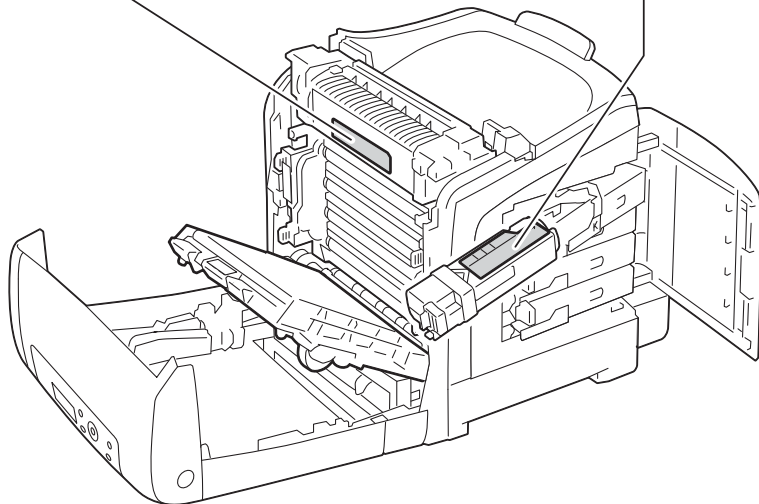
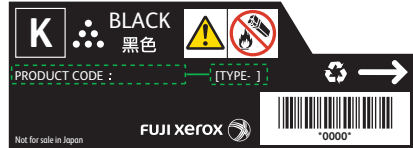
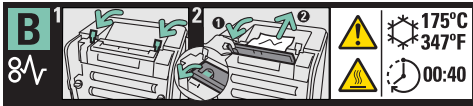

# Environment

---

- For environmental protection and efficient use of resources, Fuji Xerox reuses returned toner cartridges and drum cartridge to make recycle parts, recycle materials or energy recovery.
- Proper disposal is required for toner cartridges and drum cartridge no longer needed. Do not open toner cartridges and drum cartridge containers. Return them to your local Fuji Xerox representative.

# Regulation

---

## ■ Radio Frequency Emissions (Class B)



**NOTE:** This equipment has been tested and found to comply with the limits for a Class B digital device, pursuant to CISPR Publ.22 and Radio communication Act 1992 in Australia/NewZealand.

These limits are designed to provide reasonable protection against harmful interference in a residential installation. This equipment generates, uses and can radiate radio frequency energy and, if not installed and used in accordance with the instructions, may cause harmful interference to radio communications. However, there is no guarantee that interference will not occur in a particular installation. If this equipment does cause harmful interference to radio or television reception, which can be determined by turning the equipment off and on, the user is encouraged to try to correct the interference by one or more of the following measures:

- Reorient or relocate the receiving antenna.
- Increase the separation between the equipment and receiver.
- Connect the equipment into an outlet on a circuit different from that to which the receiver is connected.
- Consult the dealer or an experienced radio/TV technician for help.

Changes and modifications to this equipment not specifically approved by Fuji Xerox may void the user's authority to operate this product.

---

# Illegal Copies and Printouts

---

Copying or printing certain documents may be illegal in your country. Penalties of fines or imprisonment may be imposed on those found guilty. The following are examples of items that may be illegal to copy or print in your country.

- Currency
- Banknotes and checks
- Bank and government bonds and securities
- Passports and identification cards
- Copyright material or trademarks without the consent of the owner
- Postage stamps and other negotiable instruments

This list is not inclusive and no liability is assumed for either its completeness or accuracy. In case of doubt, contact your legal counsel.

# Product Features

---

This section describes the product features and indicates their links.

## 2 Sided Print (Duplex Print)

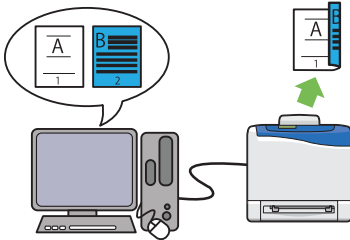

2 Sided Print is to print two or more pages on the front and back side of a single sheet of paper. This feature allows you to reduce the paper consumption.

For more information, see ["Duplex Printing" on page 124](#).

## Using the Stored Print Function (Stored Print)

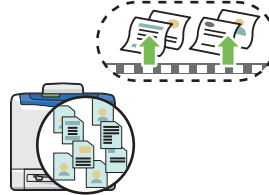

The Stored Print feature allows you to temporarily store your print data in the printer memory and output it later. You can effectively manage your time when you print confidential data or large-volume data at off-peak hours.

For more information, see ["Using the Stored Print Function" on page 120](#).

## Multiple-Up Print

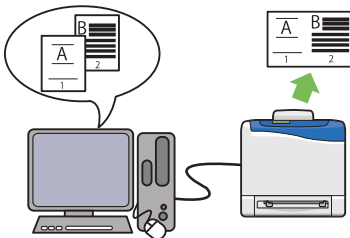



Multiple-Up enables you to print multiple pages on a single sheet of paper. This feature allows you to reduce the paper consumption.

For more information, see the print driver's help.



# Specifications

This chapter lists the main specifications of the printer. Note that the specifications of the product may change without prior notice.

Items	Description
Product Code	DocuPrint CP305 d
Type	Console
Printing method	Laser Xerography  <b>IMPORTANT:</b> <ul style="list-style-type: none"> <li>Laser + electrophotographic system</li> </ul>
Fusing system	Thermal fusing system
Warm-up Time	20 seconds or less (after powering on at 22 °C temperature)
Continuous print speed <sup>*1</sup>	A4 plain paper Color 1 Sided <sup>*2</sup> : 23 sheets/min; 2 Sided <sup>*3</sup> : 16 pages/min Monochrome 1 Sided: 23 sheets/min; 2 Sided: 16 pages/min  <b>IMPORTANT:</b> *1 Print speed may decrease due to factors such as paper type, paper size, and printing conditions. *2 When continuously printing a single document of A4  . *3 A4  continuous printing
First print	15.5 seconds  <b>IMPORTANT:</b> <ul style="list-style-type: none"> <li>Measurements based on Fuji Xerox test pattern. Time from printer startup until output of the first page is complete.</li> </ul>
Resolution	Output Resolution: 600 × 600 dpi
Tone/Color	256 tones/color (16.7 million colors)



Items	Description
Paper Size	<p>A4, B5, A5, Legal (8.5 × 14"), Folio (8.5 × 13"), Letter (8.5 × 11"), Executive, Com-10, Monarch, DL, C5, Custom Paper (Width: 76.2 – 215.9 mm, Length: 127 – 355.6 mm)</p> <p>Image loss: 4.1 mm from the top, bottom, left, and right edges</p>
Paper Type	<p>Plain Paper, Card Stock (Thin/Thick), Envelope, Labels (Normal/Thick), Letterhead, Glossy Paper (Normal/Thick), Pre-Punched, Colored Paper, Special</p> <p><b>IMPORTANT:</b></p> <ul style="list-style-type: none"> <li>• Fuji Xerox P paper (64 g/m<sup>2</sup>)</li> <li>• Use only the recommended paper. Using paper other than that recommended for the printer can cause printing problems. Do not use special ink jet paper.</li> <li>• Note that poor printing quality due to paper-related printing problems can occur when using the printer in an environment that is dry, cold, or very humid.</li> <li>• Printing over the printed side or on the reverse side of paper that already has been printed on can result in poor print quality.</li> <li>• When printing on envelopes, use envelopes that do not have adhesive applied.</li> <li>• The type of paper being used and environmental conditions can affect printing quality. Because of this, it is recommended that you test print and confirm proper print quality before using the printer.</li> </ul>
Paper capacity	<p>Standard:</p> <p>Standard 250-sheet tray: 250 sheets  Optional 250-sheet feeder: 250 sheets  SSF: 1 sheet</p> <p><b>IMPORTANT:</b></p> <ul style="list-style-type: none"> <li>• Fuji Xerox P paper (64 g/m<sup>2</sup>)</li> </ul>
Output tray capacity	<p>Standard: approximately 150 sheets (face down)</p> <p><b>IMPORTANT:</b></p> <ul style="list-style-type: none"> <li>• Fuji Xerox P paper (64 g/m<sup>2</sup>)</li> </ul>
2-sided Printing Feature	Standard
CPU	ARM11 400MHz
Memory capacity	<p>Standard: 256 MB (Onboard)  Maximum: 768 MB (Onboard256 MB + DIMM512 MB)</p> <p><b>IMPORTANT:</b></p> <ul style="list-style-type: none"> <li>• The above memory capacity does not guarantee print quality depending on the type and content of print data.</li> </ul>
Hard disk	—
Fonts	<p>Build-in fonts</p> <p>PCL5 and PCL6 fonts: 81 fonts and 36 symbol sets</p> <p>PostScript 3: 136 fonts</p> <p>PDF Font: 14 fonts</p>
Page Description Language	PCL 5e, PCL 5c, PCL 6, PostScript 3, FX-PDF, HBPL

Items	Description
Supported OS	<p>Standard: PCL6 and PostScript drivers</p> <p>Microsoft® Windows® 2000,  Microsoft® Windows® XP,  Microsoft® Windows Server® 2003,  Microsoft® Windows Server® 2008,  Microsoft® Windows Vista®,  Microsoft® Windows® 7,  Microsoft® Windows® XP x64,  Microsoft® Windows Server® 2003 x64,  Microsoft® Windows Server® 2008 x64,  Microsoft® Windows Vista® x64,  Microsoft® Windows Server® 2008 R2 x64,  Microsoft® Windows® 7 x64,  Mac OS® X 10.3 – 10.6,  Red Hat Enterprise Linux 4 WS/5 Client (x86),  SUSE Linux Enterprise Desktop 10/11 (x86)</p> <p><b>IMPORTANT:</b></p> <ul style="list-style-type: none"> <li>For information about the latest supported OS, contact our Customer Support Center.</li> </ul>
Interface	Standard: Ethernet (1000BASE-TX/100BASE-TX/10BASE-T), USB 2.0
Supported protocol	TCP/IP (LPD, Port9100, WSD, HTTP, SMTP, RARP, AutoIP, WINS, FTP, Telnet, DDNS, IPP, SMB), SNMP, DHCP, BOOTP, Bonjour (mDNS)
Power	<p>AC 110 - 127 V ± 10%; 10 A or less; both 50/60 Hz ± 3%</p> <p>AC 220 - 240 V ± 10%; 5 A or less; both 50/60 Hz ± 3%</p> <p><b>IMPORTANT:</b></p> <ul style="list-style-type: none"> <li>Power outlets that provide the above power level is recommended. Maximum machine measured current: 12.5A</li> </ul>
Operating noise (main unit only)	<p>During operation:</p> <p>color : 6.8 B; 53.5 dB (A)  monochrome : 6.8 B; 53.5 dB (A)</p> <p>During stand-by: 4.3 B</p> <p><b>IMPORTANT:</b></p> <ul style="list-style-type: none"> <li>Measurements based on ISO7779  Unit B: acoustic power level (LwAd)  Unit dB (A): radiated sound pressure (bystander position)</li> </ul>
Power consumption	<p>Maximum: 1100 W, During the Sleep mode: 8 W or less</p> <p>Average:</p> <p>During standby: 60 W,  During continuous color printing: 365 W,  During continuous monochrome printing: 365 W</p> <p><b>IMPORTANT:</b></p> <ul style="list-style-type: none"> <li>Sleep Mode: 8 W average  (The printer does not use electricity when the power is switched off even with the power cord is plugged in.)</li> </ul>

Items	Description
Dimensions (main unit only)	400 (W) x 460.9 (D) x 436.4 (H) mm
Weight	Main Unit: 19.8 kg (main unit only, including consumables)
Usage Environment	<p data-bbox="543 239 1222 297">During Use: Temperature: 5 - 32 °C; Humidity: 10 - 85% (except malfunctions due to dew condensation)</p> <p data-bbox="543 311 1204 369">Non-Use: Temperature: -20 - 40 °C; Humidity: 5 - 85% (except malfunctions due to dew condensation)</p> <p data-bbox="543 388 705 417"><b>IMPORTANT:</b></p> <ul data-bbox="550 426 1263 511" style="list-style-type: none"> <li data-bbox="550 426 1263 511">• Until the conditions (temperature and humidity) inside the printer become acclimated to the installation environment, certain qualities of the paper can cause poor printing.</li> </ul>

# Basic Operation

This chapter includes:

- ["Main Components" on page 32](#)
- ["Preparing Printer Hardware" on page 37](#)
- ["Installing Optional Accessories" on page 38](#)
- ["Turning on the Printer" on page 46](#)
- ["Printing a Panel Settings Page" on page 47](#)
- ["Power Saver Mode" on page 48](#)

# Main Components

---

This section provides an overview of your DocuPrint CP305 d.

This section includes:

- ["Front View" on page 33](#)
- ["Rear View" on page 34](#)
- ["Operator Panel" on page 35](#)
- ["Securing the Printer" on page 36](#)

## ■ Front View

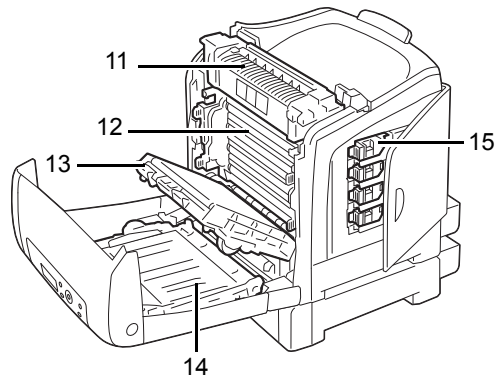
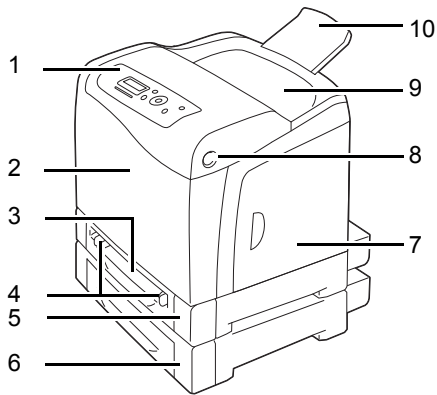

1	Operator Panel	2	Front Cover
3	Single Sheet Feeder (SSF)	4	Width Guides
5	Standard 250-Sheet Tray	6	Optional 250-Sheet Feeder
7	Side Cover	8	Side Button
9	Output Tray	10	Output Tray Extension
11	Fuser Unit	12	Drum Cartridge
13	Belt Unit	14	Duplexer
15	Toner Cartridge		

## ■ Rear View

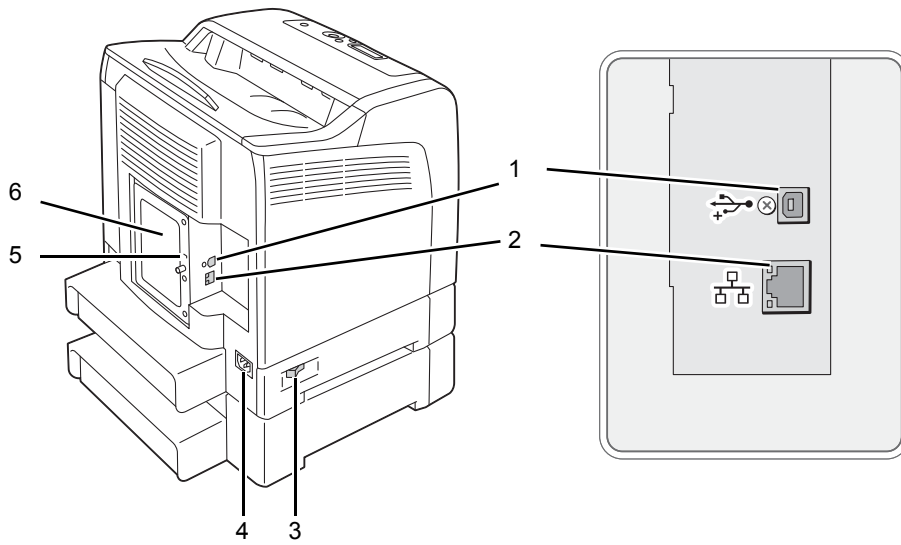

1	USB Port	2	Ethernet Port
3	Power Switch	4	Power Connector
5	Security Slot	6	Control Board Cover

# ■ Operator Panel

The operator panel has a liquid crystal display (LCD) and buttons.

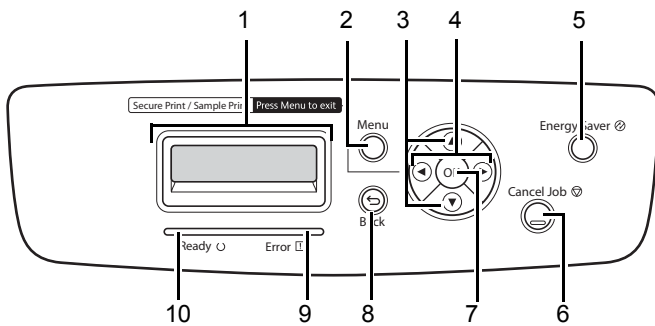

- 1 LCD Panel**
  - Displays various settings, instructions, and error messages.
- 2 Menu button**
  - Moves to the top menu.
- 3 ▲ ▼ buttons**
  - Scrolls through menus or items in the Menu mode. To enter numbers or passwords, press these buttons.
- 4 ◀ ▶ buttons**
  - Selects submenus or setting values in the Menu mode.
- 5 Energy Saver button**
  - Lights up in the Sleep mode. Press this button to exit the Sleep mode.
- 6 Cancel Job button**
  - Cancels the current print job.
- 7 OK button**
  - Displays the selected menu or item and determines the selected value in the Menu mode.
- 8 Back button**
  - Switches to the Print mode from the top menu of the Menu mode.
  - Returns to the upper hierarchy of the menu from the submenu of the Menu mode.
- 9 Error LED**
  - Lights up when the printer has an error.
- 10 Ready LED**
  - Lights up when the printer is ready.



## ■ Securing the Printer

To protect your printer from theft, you can use the optional Kensington lock.

Attach the Kensington lock to the security slot on your printer.

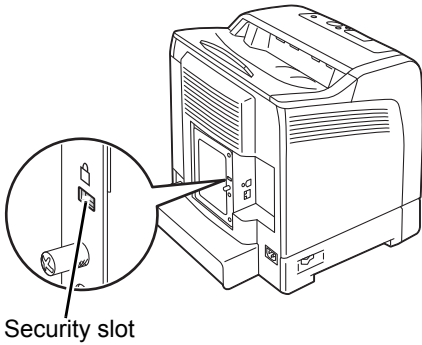

For details, see the operating instructions supplied with the Kensington lock.

# Preparing Printer Hardware

---

- 1 Open the side cover.

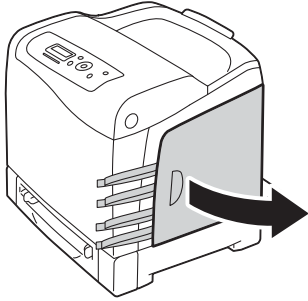

- 2 Completely pull out the eight yellow ribbons.

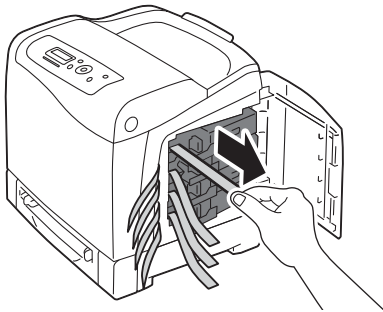

- 3 Close the side cover.

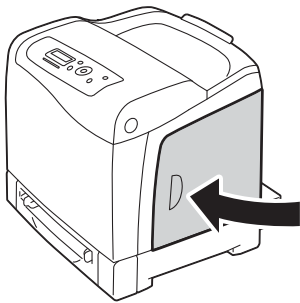

# Installing Optional Accessories

---

You can make the printer more functional by installing the optional accessories. This section describes how to install the printer's options such as the optional memory module and optional 250-sheet feeder.

This section includes:

- ["Installing the Optional Memory Module" on page 39](#)
- ["Installing the Optional 250-Sheet Feeder" on page 42](#)

## ■ Installing the Optional Memory Module

### NOTE:

- Your printer supports additional 512 MB memory module.

- 1 Turn off the printer.

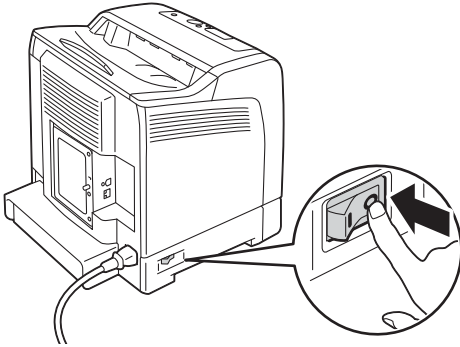

- 2 Turn the screw on the control board cover counterclockwise, and open the cover.

### NOTE:

- Loosen the screw. You do not need to remove the screw.

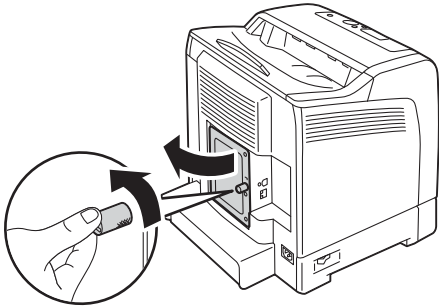

- 3 Align the connector of the memory module with the slot and insert the memory module into the slot.

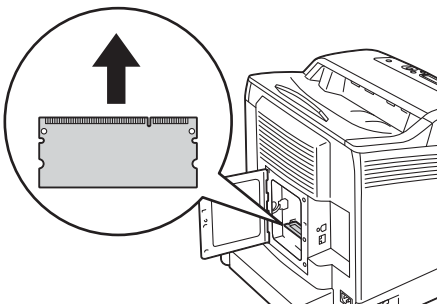

- 4 Push the memory module firmly into the slot.

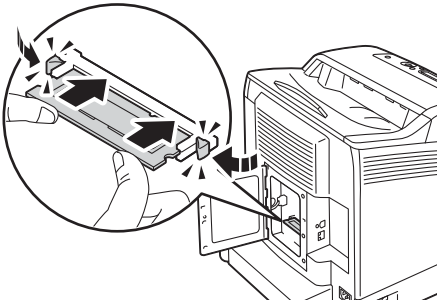

**NOTE:**

- Ensure that the memory module is firmly fixed in the slot and does not move easily.

- 5 Close the control board cover, and turn the screw clockwise.

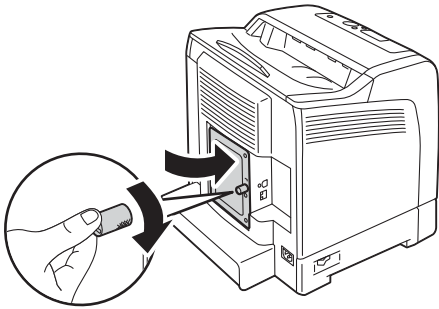

- 6 Turn on the printer.

- 7 Print the Printer Settings page to confirm that the newly installed memory module is detected by the printer.

a Press the **Menu** button.

b Select `Report/List`, and then press the **OK** button.

c Select `Printer Settings`, and then press the **OK** button.

The Printer Settings page is printed.

- 8 Confirm the amount of **Memory Capacity** listed under **General** in the Printer Settings page.

If the memory capacity has not increased, turn off the printer, unplug the power cord, and re-install the memory module.

- 9 If you installed the optional memory module after installing the print driver, update your driver by following the instructions for the operating system you are using. If the printer is on a network, update the driver for each client.

# Updating Your Driver to Detect Optional Memory Module

The following procedure uses Microsoft® Windows® and the PCL 6 driver as an example.

---

Microsoft® Windows® 7/Windows 7 x64/ Windows Server® 2008 R2 x64	<ol style="list-style-type: none"><li>1 Click <b>Start</b> → <b>Devices and Printers</b>.</li><li>2 Right-click the printer icon of the DocuPrint CP305 d and select <b>Printer properties</b>.</li><li>3 Click the <b>Options</b> tab, and then click <b>Get Information from Printer</b>.</li><li>4 Click <b>Apply</b>, and then click <b>OK</b>.</li><li>5 Close the <b>Devices and Printers</b> folder.</li></ol>
Windows Vista®/ Windows Vista x64	<ol style="list-style-type: none"><li>1 Click <b>Start</b> → <b>Control Panel</b> → <b>Hardware and Sound</b> → <b>Printers</b>.</li><li>2 Right-click the printer icon of the DocuPrint CP305 d and select <b>Properties</b>.</li><li>3 Click the <b>Options</b> tab, and then click <b>Get Information from Printer</b>.</li><li>4 Click <b>Apply</b>, and then click <b>OK</b>.</li><li>5 Close the <b>Printers</b> folder.</li></ol>
Windows Server 2008/ Windows Server 2008 x64	<ol style="list-style-type: none"><li>1 Click <b>Start</b> → <b>Control Panel</b> → <b>Printers</b>.</li><li>2 Right-click the printer icon of the DocuPrint CP305 d and select <b>Properties</b>.</li><li>3 Click the <b>Options</b> tab, and then click <b>Get Information from Printer</b>.</li><li>4 Click <b>Apply</b>, and then click <b>OK</b>.</li><li>5 Close the <b>Printers</b> folder.</li></ol>
Windows XP/ Windows XP x64/ Windows Server 2003/ Windows Server 2003 x64	<ol style="list-style-type: none"><li>1 Click <b>Start</b> (<b>start</b> for Windows XP) → <b>Printers and Faxes</b>.</li><li>2 Right-click the printer icon of the DocuPrint CP305 d and select <b>Properties</b>.</li><li>3 Click the <b>Options</b> tab, and then click <b>Get Information from Printer</b>.</li><li>4 Click <b>Apply</b>, and then click <b>OK</b>.</li><li>5 Close the <b>Printers and Faxes</b> folder.</li></ol>

---

If the printer information is not updated automatically after clicking **Get Information from Printer**, follow these steps:

- 1 Click the **Options** tab, and then select **Memory Capacity** in **Items**.
- 2 Select the total amount of the installed printer memory in **Memory Capacity**.
- 3 Click **Apply**, and then click **OK**.
- 4 Close the **Printers and Faxes** (, **Printers**, or **Devices and Printers**) folder.

## ■ Installing the Optional 250-Sheet Feeder

- 1 Turn off the printer.

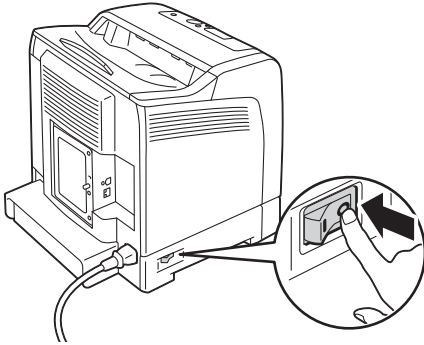

- 2 Disconnect the power cord from the power connector on the rear of the printer.

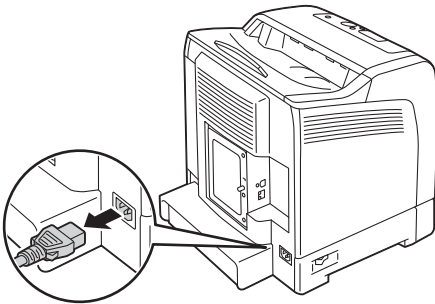

- 3 Remove the tape and the bag holding the screws.
- 4 Place the optional 250-sheet feeder in the location that the printer is located.
- 5 Pull the standard 250-sheet tray out of the printer about 200 mm. Hold the standard 250-sheet tray with both hands, and remove it from the printer.

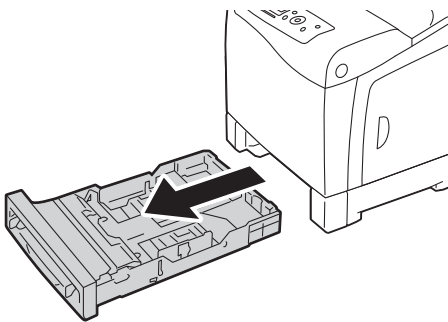

- 6 Lift the printer and align the five guide pins of the optional 250-sheet feeder with the holes at the bottom of the printer. Gently lower the printer onto the optional 250-sheet feeder.

### CAUTION:

- Two people are required to lift the printer.

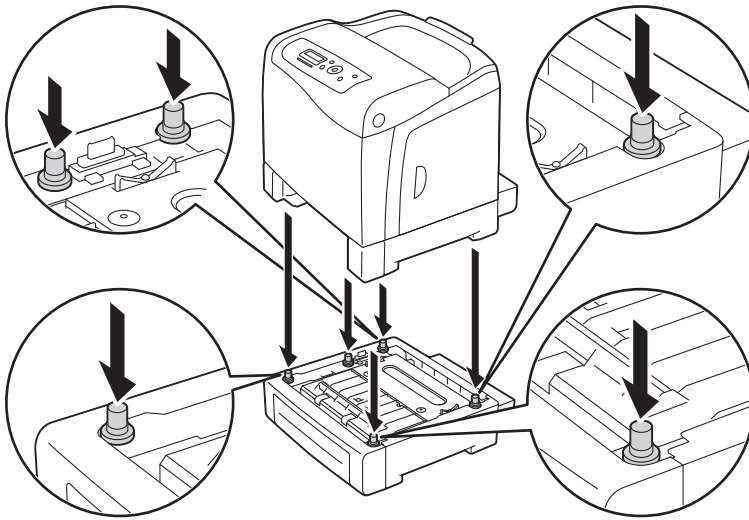

**⚠ CAUTION:**

- Be careful not to pinch your fingers when lowering the printer onto the optional 250-sheet feeder.

- 7** Secure the optional 250-sheet feeder to the printer by tightening the two screws provided with the feeder with a coin or similar object.

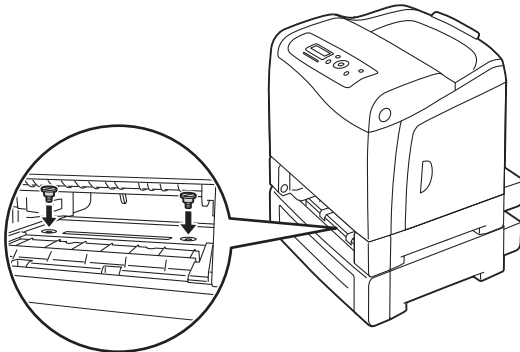

- 8** Insert the standard 250-sheet tray into the printer, and push until it stops.

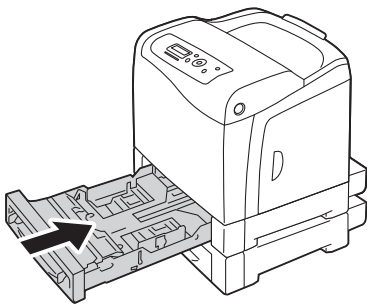



**IMPORTANT:**





- Do not use excessive force on the tray. Doing so could damage the tray or the inside of the printer.

- 9** Reconnect all cables into the rear of the printer and turn on the printer.

**NOTE:**



- The printer will automatically detect the attached tray but will not detect the paper type.
- 10** Print the Printer Settings page to confirm the optional 250-sheet feeder is installed correctly.
    - a** Press the **Menu** button.
    - b** Select `Report/List`, and then press the  button.
    - c** Select `Printer Settings`, and then press the  button.

The Printer Settings page is printed.
  - 11** Confirm **Tray 2 (250 Sheet Feeder)** is listed under **Printer Options** in the Printer Settings page. If the feeder is not listed, turn off the printer, unplug the power cord, and re-install the optional 250-sheet feeder.
  - 12** After loading paper in the optional 250-sheet feeder, specify the paper type from the printer operator panel.
    - a** Press the **Menu** button.
    - b** Select `Tray Settings`, and then press the  button.
    - c** Select `Tray 2`, and then press the  button.
    - d** Select `Paper Type`, and then press the  button.
    - e** Select the paper type for the optional 250-sheet feeder, and then press the  button.
  - 13** If you installed the optional 250-sheet feeder after installing the print driver, update your driver by following the instructions for each operating system. If the printer is on a network, update the driver for each client.

# Updating Your Driver to Detect Optional 250-Sheet Feeder

The following procedure uses Microsoft® Windows® and the PCL 6 driver as an example.

---

Microsoft Windows 7/ Windows 7 x64/ Windows Server 2008 R2 x64	<ol style="list-style-type: none"><li>1 Click <b>Start</b> → <b>Devices and Printers</b>.</li><li>2 Right-click the printer icon of the DocuPrint CP305 d and select <b>Printer properties</b>.</li><li>3 Click the <b>Options</b> tab, and then click <b>Get Information from Printer</b>.</li><li>4 Click <b>Apply</b>, and then click <b>OK</b>.</li><li>5 Close the <b>Devices and Printers</b> folder.</li></ol>
Windows Vista/ Windows Vista x64	<ol style="list-style-type: none"><li>1 Click <b>Start</b> → <b>Control Panel</b> → <b>Hardware and Sound</b> → <b>Printers</b>.</li><li>2 Right-click the printer icon of the DocuPrint CP305 d and select <b>Properties</b>.</li><li>3 Click the <b>Options</b> tab, and then click <b>Get Information from Printer</b>.</li><li>4 Click <b>Apply</b>, and then click <b>OK</b>.</li><li>5 Close the <b>Printers</b> folder.</li></ol>
Windows Server 2008/ Windows Server 2008 x64	<ol style="list-style-type: none"><li>1 Click <b>Start</b> → <b>Control Panel</b> → <b>Printers</b>.</li><li>2 Right-click the printer icon of the DocuPrint CP305 d and select <b>Properties</b>.</li><li>3 Click the <b>Options</b> tab, and then click <b>Get Information from Printer</b>.</li><li>4 Click <b>Apply</b>, and then click <b>OK</b>.</li><li>5 Close the <b>Printers</b> folder.</li></ol>
Windows XP/ Windows XP x64/ Windows Server 2003/ Windows Server 2003 x64	<ol style="list-style-type: none"><li>1 Click <b>Start</b> (<b>start</b> for Windows XP) → <b>Printers and Faxes</b>.</li><li>2 Right-click the printer icon of the DocuPrint CP305 d and select <b>Properties</b>.</li><li>3 Click the <b>Options</b> tab, and then click <b>Get Information from Printer</b>.</li><li>4 Click <b>Apply</b>, and then click <b>OK</b>.</li><li>5 Close the <b>Printers and Faxes</b> folder.</li></ol>

---

If the printer information is not updated automatically after clicking **Get Information from Printer**, follow these steps:

- 1 Click the **Options** tab, and then select **Paper Tray Configuration** in **Items**.
- 2 Select **Two trays** for the optional 250-sheet feeder setting in **Paper Tray Configuration**.
- 3 Click **Apply**, and then click **OK**.
- 4 Close the **Printers and Faxes** (, **Printers**, or **Devices and Printers**) folder.

# Turning on the Printer

---

## IMPORTANT:

- Do not use extension cords or power strips.
  - The printer should not be connected to an uninterrupted power supply (UPS) system.
- 1 Connect the power cord to the power connector on the rear of your printer.

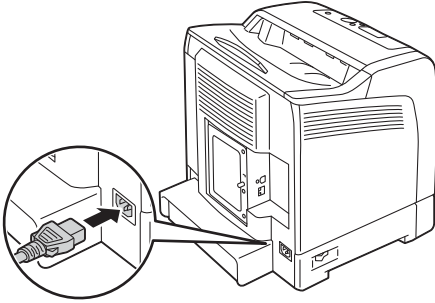

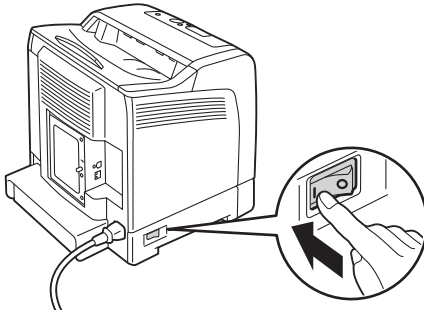

- 2 Connect the other end of the power cord to the power source.
- 3 Turn on the printer.



# Printing a Panel Settings Page

---

The Panel Settings page shows current settings for the operator panel menus.

- 1 Press the **Menu** button.
- 2 Select `Report/List`, and then press the  button.
- 3 Select `Panel Settings`, and then press the  button.  
The Panel Settings page is printed.

# Power Saver Mode

---

The printer has a power saving feature that reduces power consumption during periods of inactivity. This feature operates in two modes: the Low Power mode and Sleep mode. As delivered, the printer switches to the Low Power mode three minutes after the last print job is printed. The printer then switches to the Sleep mode after another six minutes of inactivity. When the printer is in the Low Power mode, the LCD backlight turns off. In the Sleep mode, **Energy Saver** button lights up. The display also goes blank and displays nothing.

The factory default settings of three minutes (Low Power mode) and six minutes (Sleep mode) are changeable within the range of 3 to 60 minutes (Low Power mode) and 1 to 6 minutes (Sleep mode). The printer returns to the ready-to-print state in about 30 seconds when re-activated.

## See also:

- ["Setting the Power Saver Time Option" on page 176.](#)

## ■ Exiting the Power Saver Mode

The printer automatically exits the Power Saver mode when it receives a print job from a computer. To manually exit the Low Power mode, press any button on the operator panel. To exit the Sleep mode, press the **Energy Saver** button.

### NOTE:

- Opening and closing a cover will cause the printer to exit the Low Power mode and the Sleep mode.
- When the printer is in the Sleep mode, all buttons on the operator panel except for the **Energy Saver** button do not function. To use the buttons on the operator panel, press the **Energy Saver** button to exit the Sleep mode.

### See also:

- ["Setting the Power Saver Time Option" on page 176.](#)



# Printer Management Software

Use the CD-ROMs shipped with your printer to install a combination of software programs, depending on your operating system.

This chapter includes:

- ["Print Drivers" on page 52](#)
- ["CentreWare Internet Services" on page 53](#)
- ["SimpleMonitor \(Windows Only\)" on page 55](#)
- ["Setup Disk Creation Tool \(Windows Only\)" on page 56](#)



# Print Drivers

---

To access all of your printer's features, install the print drivers from the *Driver CD Kit* or *PostScript Driver Library CD*.

- The print drivers enable your computer and printer to communicate and provide access to your printer features.

# CentreWare Internet Services

---

This section provides information on CentreWare Internet Services, a hyper text transfer protocol (HTTP)-based web page service that installs with your print driver and is accessed through your web browser.

These pages give you instant access to printer status, and printer configuration options. Anyone on your network can access the printer using their web browser software. In administrative mode you can change the configuration of the printer, and manage your printer settings without leaving your computer.

## **NOTE:**

- Users who are not given passwords by the administrator can still view the configuration settings and options in user mode. They will not be able to save or apply any changes to the current configuration.

## ■ Creating an Administrative Password

- 1 Launch your web browser.
- 2 Enter the IP address in the browser's **Address** field, and then press the **Enter** key.
- 3 Click the **Properties** tab.
- 4 In the left navigation panel, scroll down to **Security** and select **Administrator Settings**.
- 5 Select **Enabled** for **Administrator Mode**.
- 6 In the **Administrator Login ID** field, enter a name for the administrator.

**NOTE:**

- The default ID and password are "11111" and "x-admin", respectively.
- 7 In the **Administrator Password** and **Re-enter Password** fields, enter a password for the administrator.
  - 8 In the **Maximum Login Attempts** field, enter the number of login attempts allowed.
  - 9 Click **Apply**. Your new password has been set and anyone with the administrator name and password can log in and change the printer configuration and settings.

# SimpleMonitor (Windows Only)

---

You can check the printer status with SimpleMonitor. Double-click the SimpleMonitor printer icon on the taskbar at the bottom right of the screen. The **Select Printer** window appears, which displays the printer name, printer connection ports, and printer status. Check the column **Status** to know the current status of your printer.

**Status Settings** button: Displays the **Status Settings** dialog box and allows you to modify the SimpleMonitor settings.

Click the name of the desired printer listed on the **Select Printer** window. The **Printer Status** window appears.

The **Printer Status** window alerts you when there is a warning or when an error occurs, for example, when a paper jam occurs or toner is running low.

By default, the **Printer Status** window launches when printing and an error occurs. When an error occurs, the error message appears on the **Printer Status** window. You can specify the conditions for starting the **Printer Status** window in **Auto start setup**.

To change the pop-up settings for the **Printer Status** window:

The following procedure uses Microsoft® Windows® XP as an example.

- 1 Click **start** → **All Programs** → **Fuji Xerox** → **SimpleMonitor for Asia-Pacific** → **Activate SimpleMonitor**.

The **Select Printer** window appears.

- 2 Click **Status Settings**.

The **Status Settings** dialog box appears.

- 3 Select the **Pop-up Settings** tab, and then select the type of the pop-up from **Auto start setup**.

You can also check the toner level of your printer.

SimpleMonitor can be installed from the *Driver CD Kit*. It is available only for Windows.

# Setup Disk Creation Tool (Windows Only)

---

The Setup Disk Creation Tool on the *Driver CD Kit* and the print drivers on the *Driver CD Kit* and *PostScript Driver Library CD* are used to create driver installation packages that contain custom driver settings. A driver installation package can contain a group of saved print driver settings and other data for things such as:

- Print orientation and Multiple Up (document settings)
- Watermarks
- Font references

If you want to install the print driver with the same settings on multiple computers running the same operating system, create a setup disk in a floppy disk or in a server on the network. Using the setup disk that you have created will reduce the amount of work required when installing the print driver.

- Install the DocuPrint CP305 d driver in the computer on which the setup disk is to be created.
- The setup disk can only be used on the operating system on which the disk was created or computers running the same operating system. Create a separate setup disk for each of the operating systems.

# Network Basics

This chapter includes:

- ["Overview of Network Setup and Configuration" on page 58](#)
- ["Connecting Your Printer" on page 59](#)
- ["Setting the IP Address" on page 63](#)
- ["Installing Print Driver on Computers Running Windows" on page 71](#)
- ["Installing Print Driver on Computers Running Mac OS X" on page 81](#)
- ["Installing Print Driver on Computers Running Linux \(CUPS\)" on page 82](#)

# Overview of Network Setup and Configuration

---

To set up and configure the network:

- 1 Connect the printer to the network using the recommended hardware and cables.
- 2 Turn on the printer and the computer.
- 3 Print the Printer Settings page and keep it for referencing network settings.
- 4 Install the driver software on the computer from the *Driver CD Kit* or *PostScript Driver Library CD*. For information on driver installation, see the section in this chapter for the specific operating system you are using.
- 5 Configure the printer's TCP/IP address, which is required to identify the printer on the network.
  - Microsoft® Windows® operating systems: Run the Installer on the *Driver CD Kit* or *PostScript Driver Library CD* to automatically set the printer's IP address if the printer is connected to an established TCP/IP network. You can also manually set the printer's IP address on the operator panel.
  - Mac OS® X and Linux systems: Manually set the printer's TCP/IP address on the operator panel.
- 6 Print a Printer Settings page to verify the new settings.

## NOTE:

- If the *Driver CD Kit* or *PostScript Driver Library CD* is not available, you can download the latest driver from the Fuji Xerox Web Site: <http://www.fujixeroxprinters.com/>

## See also:

- "Printing a Printer Settings Page" on page 136

# Connecting Your Printer

Your DocuPrint CP305 d interconnection cables must meet the following requirements:

Connection Type	Connection Specifications
USB	USB 2.0
Ethernet	10 Base-T/100 Base-TX/1000 Base-TX

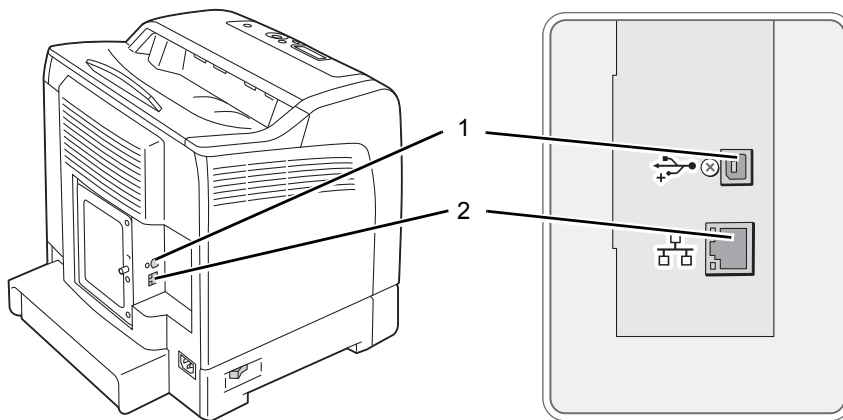

1 USB port



2 Ethernet port





## ■ Connecting Printer to Computer or Network

Connect the printer via Ethernet or USB. A USB connection is a direct connection and is not used for networking. An Ethernet connection is used for networking. Hardware and cabling requirements vary for the different connection methods. Ethernet cable and hardware are generally not included with your printer and must be purchased separately.

The available features for each connection type are shown in the following table.

<b>Connection Type</b>	<b>Available Features</b>
USB	When connected via USB you can: <ul style="list-style-type: none"><li>• Instruct print jobs from a computer.</li></ul>
Ethernet	When connected via Ethernet you can: <ul style="list-style-type: none"><li>• Instruct print jobs from a computer on the network.</li></ul>

## USB Connection

A local printer is directly connected to your computer using the USB cable. If your printer is connected to a network instead of your computer, skip this section and go to ["Network Connection" on page 62](#).

To connect the printer to a computer:

- 1 Connect the smaller USB connector into the USB port on the rear of the printer.

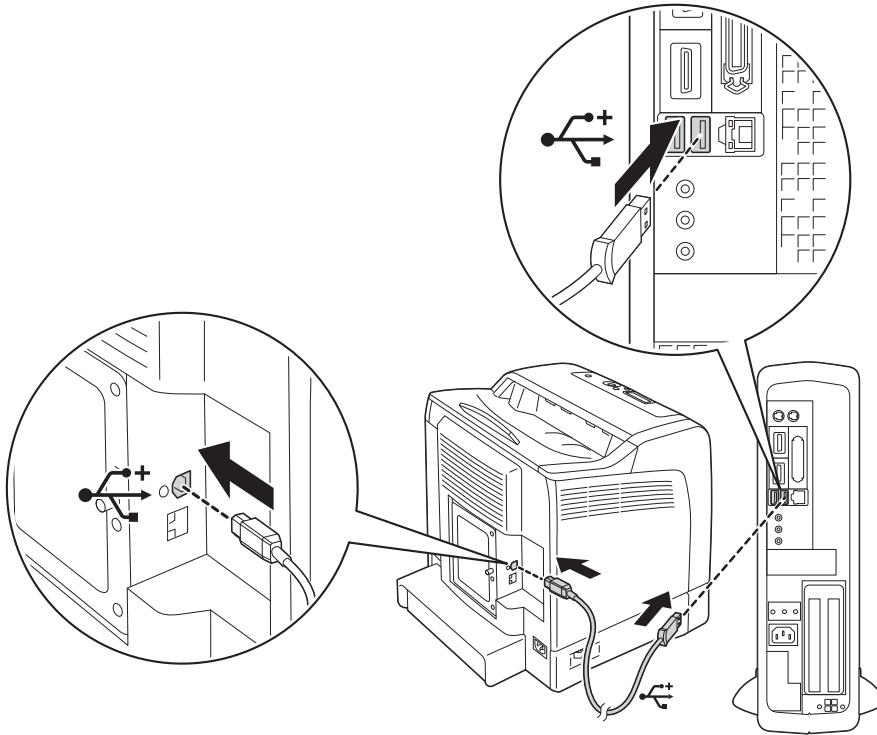

### NOTE:

- Ensure that you match the USB symbol on the cable to the USB symbol on the printer.

- 2 Connect the other end of the cable into a USB port of the computer.

### NOTE:

- Do not connect the printer USB cable to the USB port available on the keyboard.

## Network Connection

To connect the printer to a network:

- 1 Connect an Ethernet cable.

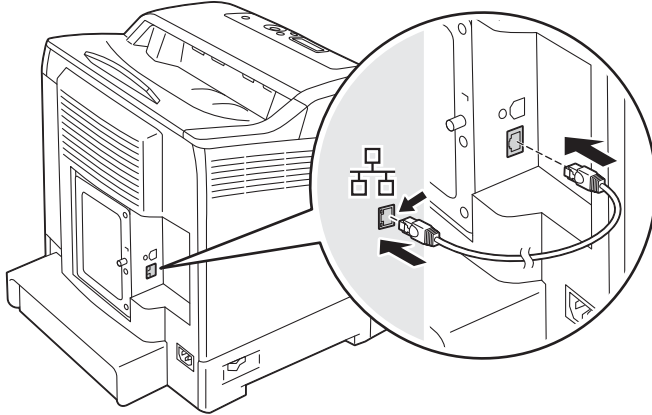

To connect the printer to the network, connect one end of the Ethernet cable into the Ethernet port on the rear of the printer, and the other end to a LAN drop or hub.

# Setting the IP Address

---

This section includes:

- ["TCP/IP and IP Addresses" on page 64](#)
- ["Automatically Setting the Printer's IP Address" on page 65](#)
- ["Dynamic Methods of Setting the Printer's IP Address" on page 66](#)
- ["Assigning an IP Address \(for IPv4 Mode\)" on page 67](#)
- ["Verifying the IP Settings" on page 69](#)
- ["Printing and Checking the Printer Settings Page" on page 70](#)

## ■ TCP/IP and IP Addresses

If your computer is on a large network, contact your network administrator for the appropriate TCP/IP addresses and additional system settings information.

If you are creating your own small Local Area Network or connecting the printer directly to your computer using Ethernet, follow the procedure for automatically setting the printer's IP address.

Computers and printers primarily use TCP/IP protocols to communicate over an Ethernet network. With TCP/IP protocols, each printer and computer must have a unique IP address. It is important that the addresses are similar, but not the same; only the last digit needs to be different. For example, your printer can have the address 192.168.1.2 while your computer has the address 192.168.1.3. Another device can have the address 192.168.1.4.

Many networks have a Dynamic Host Configuration Protocol (DHCP) server. A DHCP server automatically programs an IP address into every computer and printer on the network that is configured to use DHCP. A DHCP server is built into most cable and Digital Subscriber Line (DSL) routers. If you use a cable or DSL router, see your router's documentation for information on IP addressing.

## ■ Automatically Setting the Printer's IP Address

If the printer is connected to a small established TCP/IP network without a DHCP server, use the installer on the *Driver CD Kit* or *PostScript Driver Library CD* to detect or assign an IP address to your printer. For further instructions, insert the *Driver CD Kit* or *PostScript Driver Library CD* into your computer's CD-ROM drive. After the Installer launches, follow the prompts for installation.

### NOTE:

- For the automatic installer to function, the printer must be connected to an established TCP/IP network.

## ■ Dynamic Methods of Setting the Printer's IP Address

There are two protocols available for dynamically setting the printer's IP address:

- DHCP (enabled by default)
- AutoIP

You can turn on/off both protocols using the operator panel, or use CentreWare Internet Services to turn on/off DHCP.

### NOTE:

- You can print a report that includes the printer's IP address. On the operator panel, press the **Menu** button, select **Report/List**, press the **OK** button, select **Printer Settings**, and then press the **OK** button. The IP address is listed on the Printer Settings page.

## Using the Operator Panel

To turn on/off either the DHCP or AutoIP protocol:

- 1 On the operator panel, press the **Menu** button.
- 2 Select **Admin Menu**, and then press the **OK** button.
- 3 Select **Wired Network**, and then press the **OK** button.
- 4 Select **TCP/IP**, and then press the **OK** button.
- 5 Select **IPv4**, and then press the **OK** button.
- 6 Select **Get IP Address**, and then press the **OK** button.
- 7 Select **DHCP / Autonet**, and then press the **OK** button.

## Using CentreWare Internet Services

To turn on/off the DHCP protocol:

- 1 Launch your web browser.
- 2 Enter the IP address in the browser's **Address** field, and then press the **Enter** key.
- 3 Select **Properties**.
- 4 Select the **Protocol Settings** folder on the left navigation panel.
- 5 Select **TCP/IP**.
- 6 In the **Get IP Address** field, select the **DHCP / Autonet** option.
- 7 Click the **Apply** button.

## ■ Assigning an IP Address (for IPv4 Mode)



### NOTE:

- When you assign an IP address manually in **IPv6** mode, use the CentreWare Internet Services. To display the CentreWare Internet Services, use the link local address. To check a link local address, see ["Printing and Checking the Printer Settings Page" on page 70](#).
- Assigning an IP address is considered as an advanced function and is normally done by a system administrator.
- Depending on the address class, the range of the IP address assigned may be different. On Class A, for example, an IP address in the range from 0 . 0 . 0 . 0 to 127 . 255 . 255 . 255 will be assigned. For assignment of IP addresses, contact your system administrator.

You can assign the IP address by using the operator panel.

- 1 Turn on the printer.  
Ensure that `Ready` message appears on the LCD panel.
- 2 On the operator panel, press the **Menu** button.
- 3 Select `Admin Menu`, and then press the **OK** button.
- 4 Select `Wired Network`, and then press the **OK** button.
- 5 Select `TCP/IP`, and then press the **OK** button.
- 6 Select `IPv4`, and then press the **OK** button.
- 7 Select `Get IP Address`, and then press the **OK** button.
- 8 Select `Panel`, and then press the **OK** button.
- 9 Ensure that the message `Restart Printer to apply setting` appears, and then press any button.
- 10 Press the **▼** button to select `IP Address`, and then press the **OK** button.  
The cursor is located at the first octet of the IP address.
- 11 Specify the value of the IP address using the **▲** or **▼** button.
- 12 Press the **▶** button.  
The cursor moves to the next octet.
- 13 Repeat steps 11 to 12 to set all of the digits in the IP address, and then press the **OK** button.
- 14 Ensure that the message `Restart Printer to apply setting` appears, and then press any button.
- 15 Press the **▼** button to select `Subnet Mask`, and then press the **OK** button.  
The cursor is located at the first octet of the subnet mask.
- 16 Specify the value of the subnet mask using the **▲** or **▼** button.
- 17 Press the **▶** button.  
The cursor moves to the next octet.
- 18 Repeat steps 16 to 17 to set subnet mask, and then press the **OK** button.



- 19** Ensure that the message `Restart Printer to apply setting` appears, and then press any button.
- 20** Press the ▼ button to select `Gateway Address`, and then press the  button. The cursor is located at the first octet of the gateway address.
- 21** Specify the value of the gateway address using the ▲ or ▼ button.
- 22** Press the ► button. The cursor moves to the next octet.
- 23** Repeat steps 21 to 22 to set gateway address, and then press the  button.
- 24** Ensure that the message `Restart Printer to apply setting` appears, and then press any button.
- 25** Turn off and turn on the printer.

**See also:**

- ["Operator Panel" on page 35](#)

## ■ Verifying the IP Settings

You can confirm the settings by printing the system settings report or using the ping command.

The following procedure uses Windows XP as an example.

- 1 Print the Printer Settings page.
- 2 Look under the **IPv4** heading on the Printer Settings page to ensure that the IP address, subnet mask, and gateway are appropriate.

To verify if the printer is active on the network, run the ping command in your computer:



- 1 Click **start**, and select **Run**.
- 2 Enter **cmd**, and then click **OK**.  
A black window is displayed.
- 3 Enter **ping xx.xx.xx.xx** (where **xx.xx.xx.xx** is the IP address of your printer), and then press the **Enter** key.
- 4 Reply from the IP address denotes printer is active on the network.

### See also:

- ["Printing and Checking the Printer Settings Page" on page 70](#)

## ■ Printing and Checking the Printer Settings Page

Print the Printer Settings page and check your printer's IP address by using the operator panel.

- 1 On the operator panel, press the **Menu** button.
- 2 Select `Report/List`, and then press the  button.
- 3 Select `Printer Settings`, and then press the  button.  
The Printer Settings page is printed.
- 4 Confirm the IP address next to **IP Address** under **Network (Wired)** on the Printer Settings page. If the IP address is **0.0.0.0**, wait for a few minutes to resolve the IP address automatically, and then print the Printer Settings page again.  
If the IP address is not resolved automatically, see ["Assigning an IP Address \(for IPv4 Mode\)"](#) on [page 67](#).

# Installing Print Driver on Computers Running Windows

---

This section includes:

- ["Identifying Print Driver Pre-install Status \(For Network Connection Setup\)" on page 72](#)
- ["Inserting the CD-ROM" on page 73](#)
- ["USB Connection Setup" on page 74](#)
- ["Network Connection Setup" on page 75](#)
- ["Setting Up for Shared Printing" on page 76](#)



## ■ Identifying Print Driver Pre-install Status (For Network Connection Setup)

Before installing the print driver on your computer, print the Printer Settings page to check the IP address of your printer.

This section includes:

- ["The Operator Panel" on page 72](#)
- ["Disabling the Firewall Before Installing Your Printer" on page 72](#)

### The Operator Panel

- 1 Press the **Menu** button.
- 2 Select `Report/List`, and then press the  button.
- 3 Select `Printer Settings`, and then press the  button.  
The Printer Settings page is printed.
- 4 Find the IP address under **Network (Wired)** on the Printer Settings page.  
If the IP address is **0.0.0.0**, wait for a few minutes to resolve the IP address automatically, and then print the Printer Settings page again.  
  
If the IP address is not resolved automatically, see ["Assigning an IP Address \(for IPv4 Mode\)" on page 67](#).

### Disabling the Firewall Before Installing Your Printer

#### NOTE:

- For Windows XP, Service Pack 2 or 3 must be installed.

If you are running one of the following operating systems, you must disable the firewall before installing the Fuji Xerox printer software:

- Windows 7
- Windows Vista
- Windows Server 2008 R2
- Windows Server 2008
- Windows XP

The following procedure uses Windows XP as an example.

- 1 Click **start** → **Help and Support**.

#### NOTE:

- For Windows Vista, Windows Server 2008, Windows Server 2008 R2 and Windows 7 operating systems, if you use **Online Help**, switch to **Offline Help** on **Windows Help and Support** window.

- 2 In the **Search** box, enter **firewall** and then press the **Enter** key.  
In the list, click **Turn Windows Firewall on or off** and then follow the instructions on the screen.  
Enable the firewall after the installation of the Fuji Xerox printer software is complete.

## ■ Inserting the CD-ROM

### For Installing PCL Print Driver

- 1 Insert the *Driver CD Kit* into your computer to start **Easy Install Navi**.

**NOTE:**

- If the CD does not automatically launch, click **Start** (**start** for Windows XP) → **All Programs** (for Windows Vista and Windows 7) → **Accessories** (for Windows Vista and Windows 7) → **Run**, and then enter **D:\setup.exe** (where D is the drive letter of your CD), and then click **OK**.

### For Installing PostScript Print Driver

- 1 Insert the *PostScript Driver Library CD* into your computer.

## ■ USB Connection Setup

### For Installing PCL Print Driver

- 1 Click **Installing Driver and Software**.
- 2 Click **Print Driver**.
- 3 Click **Connect via USB**.
- 4 Follow the procedures described in the Help to install the print driver.

### • USB Printing

A personal printer is a printer attached to your computer or a print server using a USB. If your printer is attached to a network and not your computer, see ["Network Connection Setup" on page 75](#).

### For Installing PostScript Print Driver

Windows users should read the *PostScript User Guide* for information on how to install the print driver.

## ■ Network Connection Setup

### NOTE:

- To use this printer in a Linux environment, you need to install a Linux driver. For more information on how to install and use these, see also "[Installing Print Driver on Computers Running Linux \(CUPS\)](#)" on page 82.
- When using a CD drive in a Linux environment, you need to mount the CD according to your system environment. The command strings are mount/media/CD-ROM.

### For installing PCL print driver

- 1 Click **Installing Driver and Software**.
- 2 Click **Print Driver**.
- 3 Select **Standard** or **Custom** setup.
- 4 Follow the on-screen instructions to install the print driver.

### For installing PostScript print driver

Windows users should read the *PostScript User Guide* for information on how to install the print driver.



## ■ Setting Up for Shared Printing

You can share your new printer on the network using the *Driver CD Kit* that comes with your printer, or using Microsoft peer-to-peer method. However, if you use the Microsoft method, some features, such as the SimpleMonitor and other printer utilities, installed with the *Driver CD Kit*, may not be available.

If you want to use the printer on a network, share the printer and install its drivers on all the computers on the network.

### NOTE:

- You need to purchase an Ethernet cable for shared printing.
- **For Windows XP, Windows XP 64-bit Edition, Windows Server 2003, and Windows Server 2003 x64 Edition**
    - 1 Click **Start** (**start** for Windows XP) → **Printers and Faxes**.
    - 2 Right-click the printer icon and select **Properties**.
    - 3 On the **Sharing** tab, select the **Share this printer** radio button, and then enter a name in **Share name** text box.
    - 4 Click **Additional Drivers** and select the operating systems of all network clients that print to the printer.
    - 5 Click **OK**.  
If you are missing files, you are prompted to insert the server operating system CD.
    - 6 Click **Apply**, and then click **OK**.
  - **For Windows Vista and Windows Vista 64-bit Edition**
    - 1 Click **Start** → **Control Panel** → **Hardware and Sound** → **Printers**.
    - 2 Right-click the printer icon and select **Sharing**.
    - 3 Click **Change sharing options**.  
The message **Windows needs your permission to continue** appears.
    - 4 Click **Continue**.
    - 5 Select the **Share this printer** check box, and then enter a name in **Share name**.
    - 6 Click **Additional Drivers** and select the operating systems of all network clients that print to the printer.
    - 7 Click **OK**.
    - 8 Click **Apply**, and then click **OK**.

## • For Windows Server 2008 and Windows Server 2008 64-bit Edition

- 1 Click **Start** → **Control Panel** → **Printers**.
- 2 Right-click the printer icon and select **Sharing**.
- 3 Select the **Share this printer** check box, and then enter a name in **Share name**.
- 4 Click **Additional Drivers** and select the operating systems of all network clients that print to the printer.
- 5 Click **OK**.
- 6 Click **Apply**, and then click **OK**.

## • For Windows 7, Windows 7 64-bit Edition, and Windows Server 2008 R2

- 1 Click **Start** → **Devices and Printers**.
- 2 Right-click the printer icon and select **Printer properties**.
- 3 On the **Sharing** tab, select the **Share this printer** check box, and then enter a name in **Share name** text box.
- 4 Click **Additional Drivers** and select the operating systems of all network clients that print to the printer.
- 5 Click **OK**.
- 6 Click **Apply**, and then click **OK**.

To confirm that the printer is properly shared:

- Ensure that the printer object in the **Printers, Printers and Faxes** or **Devices and Printers** folder is shared. The shared icon is shown under the printer icon.
- Browse **Network** or **My Network Places**. Find the host name of the server and the shared name you assigned to the printer.

Now that the printer is shared, you can install the printer on network clients using the peer-to-peer method.

## Peer-to-Peer

If you use the peer-to-peer method, the print driver is fully installed on each client computer. Network clients retain control of driver modifications. The client computer handles the print job processing.

## • For Windows XP, Windows XP 64-bit Edition, Windows Server 2003, and Windows Server 2003 x64 Edition

- 1 Click **start** (**Start** for Windows Server 2003 / Windows Server 2003 x64 Edition) → **Printers and Faxes**.
- 2 Click **Add a printer** (**Add Printer** for Windows Server 2003 / Windows Server 2003 x64 Edition) to launch the **Add Printer Wizard**.
- 3 Click **Next**.
- 4 Select **A network printer, or a printer attached to another computer**, and then click **Next**. If the printer is not listed, enter the path to the printer in the text box.

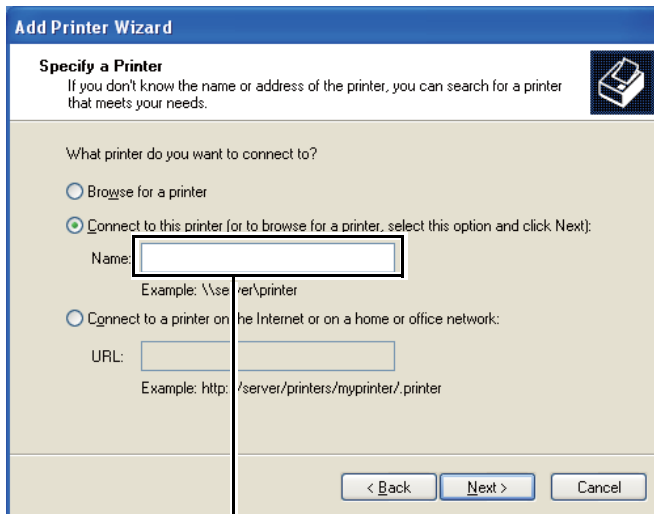

For example: \\<server host name>\<shared printer name>

The server host name is the name of the server computer that identifies it on the network. The shared printer name is the name assigned during the server installation process.

- 5 Click **Browse for a printer**, and then click **Next**.
- 6 Select the printer, and then click **Next**.  
If this is a new printer, you may be prompted to install a print driver. If no system driver is available, you need to specify the path to available drivers.
- 7 Select **Yes** if you want this printer to be set as the default printer, and then click **Next**.  
If you want to verify installation, click **Yes** to print a test page.
- 8 Click **Finish**.  
When a test page prints successfully, installation is complete.

## • For Windows Vista and Windows Vista 64-bit Edition

- 1 Click **Start** → **Control Panel** → **Hardware and Sound** → **Printers**.
- 2 Click **Add a Printer** to launch the **Add Printer** wizard.
- 3 Select **Add a network, wireless or Bluetooth printer**, and then click **Next**. If the printer is listed, select the printer and click **Next**, or select **The printer that I want isn't listed** and enter the path of the printer in **Select a shared printer by name** and click **Next**.

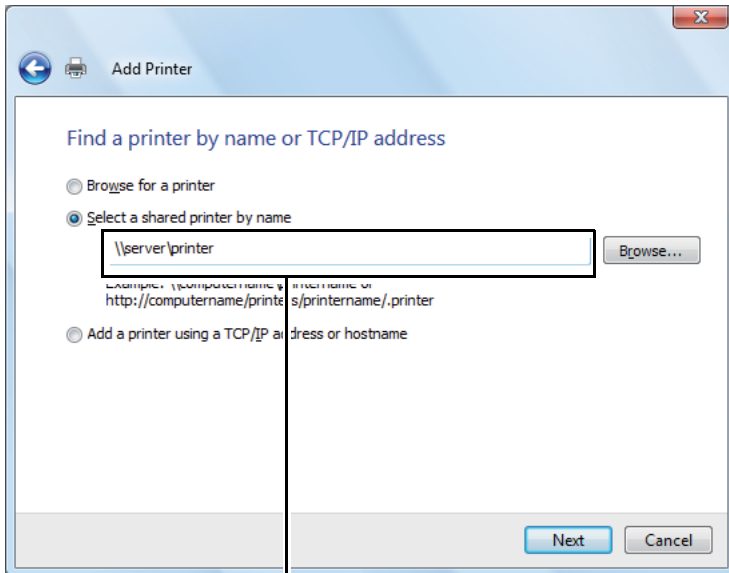

For example: \\<server host name>\<shared printer name>

The server host name is the name of the server computer that identifies it on the network. The shared printer name is the name assigned during the server installation process.

- 4 If this is a new printer, you may be prompted to install a print driver. If no system driver is available, you need to specify the path to available drivers.
- 5 Select **Yes** if you want this printer to be set as the default printer, and then click **Next**.
- 6 If you want to verify installation, click **Print a test page**.
- 7 Click **Finish**.

When a test page prints successfully, installation is complete.

## • For Windows Server 2008 and Windows Server 2008 64-bit Edition

- 1 Click **Start** → **Control Panel** → **Printers**.
- 2 Click **Add a Printer** to launch the **Add Printer** wizard.
- 3 Select **Add a network, wireless or Bluetooth printer**, and then click **Next**. If the printer is listed, select the printer and click **Next**, or select **The printer that I want isn't listed** and enter the path to the printer in **Select a shared printer by name** and click **Next**.  
For example: \\<server host name>\<shared printer name>  
The server host name is the name of the server computer that identifies it on the network. The shared printer name is the name assigned during the server installation process.
- 4 If this is a new printer, you may be prompted to install a print driver. If no system driver is available, you will need to provide a path to available drivers.
- 5 Select **Yes** if you want this printer to be set as the default printer, and then click **Next**.
- 6 Click **Print a test page** if you want to verify installation.
- 7 Click **Finish**.  
When a test page prints successfully, installation is complete.

## • For Windows 7, Windows 7 64-bit Edition, and Windows Server 2008 R2

- 1 Click **Start** → **Devices and Printers**.
- 2 Click **Add a Printer** to launch the **Add Printer** wizard.
- 3 Select **Add a network, wireless or Bluetooth printer**. If the printer is listed, select the printer and click **Next**, or select **The printer that I want isn't listed**. Click **Select a shared printer by name** and enter the path of the printer in the text box, and then click **Next**.  
For example: \\<server host name>\<shared printer name>  
The server host name is the name of the server computer that identifies it to the network. The shared printer name is the name assigned during the server installation process.
- 4 If this is a new printer, you may be prompted to install a print driver. If no system driver is available, you will need to provide the path to the available driver.
- 5 Confirm the printer name, and then click **Next**.
- 6 Select **Yes** if you want this printer to be set as the default printer, and then click **Next**.
- 7 Click **Print a test page** if you want to verify installation.
- 8 Click **Finish**.  
When a test page prints successfully, installation is complete.

# Installing Print Driver on Computers Running Mac OS X

---

For information on how to install the print driver, refer to the *PostScript User Guide*.

# Installing Print Driver on Computers Running Linux (CUPS)

---

This section provides information for installing or setting up the print driver with CUPS (Common UNIX Printing System) on Red Hat® Enterprise Linux® 4 WS/5 Client or SUSE® Linux Enterprise Desktop 10/11.

This section includes:

- ["Installing the Print Driver" on page 83](#)
- ["Setting Up the Queue" on page 84](#)
- ["Setting the Default Queue" on page 87](#)
- ["Specifying the Printing Options" on page 88](#)
- ["Setting the Password for Authority as the Printer Administrator" on page 90](#)
- ["Uninstalling the Print Driver" on page 91](#)

## ■ Installing the Print Driver

This section includes:

- "For Red Hat Enterprise Linux 4 WS/5 Client" on page 83
- "For SUSE Linux Enterprise Desktop 10" on page 83
- "For SUSE Linux Enterprise Desktop 11" on page 83

### NOTE:

- The print driver **Fuji\_Xerox-DocuPrint\_CP305\_d-x.x-y.noarch.rpm** is included in the **Linux** folder in the **Common** folder on the *Driver CD Kit*.

### • For Red Hat Enterprise Linux 4 WS/5 Client

#### IMPORTANT:

- Before you install the print driver on Red Hat Enterprise Linux 4, confirm that Update 8 or higher is applied to your operating system. Consult your Linux distributor for the upgrade of your system.

- 1 Double-click **Fuji\_Xerox-DocuPrint\_CP305\_d-x.x-y.noarch.rpm** in the *Driver CD Kit*.
- 2 Enter the administrator's password.
- 3 Click **Continue** in the **Completed System Preparation** window.  
Installation starts. When the installation is complete, the window is automatically closed.

### • For SUSE Linux Enterprise Desktop 10

- 1 Double-click **Fuji\_Xerox-DocuPrint\_CP305\_d-x.x-y.noarch.rpm** in the *Driver CD Kit*.
- 2 Enter the administrator password, and click **Install**.  
Installation starts. When the installation is complete, the window is automatically closed.

### • For SUSE Linux Enterprise Desktop 11

- 1 Double-click **Fuji\_Xerox-DocuPrint\_CP305\_d-x.x-y.noarch.rpm** in the *Driver CD Kit*.
- 2 Enter the administrator password, and click **Continue**.  
Installation starts. When the installation is complete, the window is automatically closed.



## ■ Setting Up the Queue

To execute printing, you must set up the print queue on your workstation.

### NOTE:

- When you have finished setting up the queue, you can print jobs from the applications. Start the print job from the application, and specify the queue in the print dialog box. However, you may be able to print only from the default queue depending on the application (for example Mozilla). In these cases, before you start printing, set queue you want to print to as the default queue. For information on specifying the default queue, see also "[Setting the Default Queue](#)" on page 87.

### • For Red Hat Enterprise Linux 4 WS/5 Client

**1** Open the URL "<http://localhost:631>" using a web browser.

**2** Click **Administration**.

**3** Enter **root** as the user name, and enter the administrator password.

**4** Click **Add Printer**.

Enter the name of the printer in **Name** in the **Add New Printer** window, and click **Continue**.

You can optionally specify the location and description of the printer for further information.

For network connections:

**a** Select **LPD/LPR Host or Printer** from the **Device** menu, and click **Continue**.

**b** Enter the IP address of the printer in **Device URI**.

**c** Format: **lpd://xxx.xxx.xxx.xxx** (the IP address of the printer)

For USB connections with Red Hat Enterprise Linux 4 WS:

**a** Select **USB Printer #1** from the **Device** menu.

For USB connections with Red Hat Enterprise Linux 5 Client:

**a** Select **DocuPrint XXX USB #1** or **DocuPrint XXX** from the **Device** menu.

**5** Select **Fuji Xerox** from the **Make** menu, and click **Continue**.

**6** Select **DocuPrint XXX** from the **Model** menu, and click **Continue**.

The message **Printer xxx has been added successfully.** appears.

The setup is complete.

## • For SUSE Linux Enterprise Desktop 10

1 Select **Computer** → **More Applications...** and select **YaST** on the Application Browser.

2 Enter the administrator password.  
**YaST Control Center** is activated.

3 Select **Hardware** on **YaST Control Center**, and select **Printer**.

4 **Printer setup: Autodetected printers** is activated.

For network connections:

a Click **Add**.

b Select **Network Printers** as **Printer Type**, and click **Next**.

c Select the **Print via LPD-Style Network Server** as **Printer Type**, and click **Next**.

d Enter the IP address of the printer in **Host name of the printer server**.

e Enter the name of the printer queue in **Name of the remote queue**, and click **Next**.

f Enter the printer name in **Name for printing**.

### NOTE:

• The **Description of Printer** and **Location of Printer** do not have to be specified.

g Select the **Do Local Filtering** check box, and click **Next**.

h Select **Fuji Xerox** as **Select manufacturer**. Select **XXX** as **Select Model**, and click **Next**.

i Confirm the settings in **Edit configuration**, and click **OK**.

For USB connections:

a Select **DocuPrint XXX on USB (//DocuPrint/XXX or /dev/usb\*lp\*)** as **Available are**, and click **Configure....**

b Confirm the settings in **Edit configuration**, and click **OK**.

5 Click **Finish**.

## • For SUSE Linux Enterprise Desktop 11

- 1 Select **Computer** → **More Applications...**, and select **YaST** on the Application Browser.
- 2 Enter the administrator password.  
**YaST Control Center** is activated.
- 3 Select **Hardware** on **YaST Control Center**, and select **Printer**.  
The **Printer Configurations** dialog box opens.  
For network connections:
  - a Click **Add**.  
The **Add New Printer Configuration** dialog box opens.
  - b Click **Connection Wizard**.  
The **Connection Wizard** dialog box opens.
  - c Select **Line Printer Daemon (LPD) Protocol** from **Access Network Printer or Printserver Box via**.
  - d Enter the IP address of the printer in **IP Address or Host Name**:.  
e Select **Fuji Xerox** in **Select the printer manufacturer**:.  
f Click **OK**.  
The **Add New Printer Configuration** dialog box appear.
  - g Select **DocuPrint XXX vx.x [DocuPrint/DocuPrint\_XXX.ppd.gz]** from the **Search for Drivers**: list.

### NOTE:

- You can specify the printer name in **Set Name**:.  
h Confirm the settings, and click **OK**.

For USB connections:

- a Click **Add**.  
The **Add New Printer Configuration** dialog box opens.  
The printer name is displayed in the **Determine Connection** list.
- b Select **DocuPrint XXX vx.x. [DocuPrint/DocuPrint\_XXX.ppd.gz]** from the **Search for Drivers**: list.

### NOTE:

- You can specify the printer name in **Set Name**:.  
h Confirm the settings, and click **OK**.

## ■ Setting the Default Queue

### • For Red Hat Enterprise Linux 4 WS/5 Client

- 1 Select **Applications** → **System Tools** → **Terminal**.
- 2 Enter the following command in the terminal window.

```
su  
(Enter the administrator password)  
lpadmin -d (Enter the queue name)
```

### • For SUSE Linux Enterprise Desktop 10

- 1 To activate the **Printer setup: Autodetected printers**, do the following.
  - a Select **Computer** → **More Applications...** and select **YaST** on the Application Browser.
  - b Enter the administrator password.  
**YaST Control Center** is activated.
  - c Select **Hardware** on **YaST Control Center**, and select **Printer**.
- 2 Select the printer you want to set to default on the **Printer Configuration**, and select **Set default** in the **Other button menu**.
- 3 Click **Finish**.

### • For SUSE Linux Enterprise Desktop 11

- 1 Select **Computer** → **More Applications...**, and select **YaST** on the Application Browser.
- 2 Enter the administrator password.  
**YaST Control Center** is activated.
- 3 Select **Hardware** on **YaST Control Center**, and select **Printer**.  
The **Printer Configurations** dialog box opens.
- 4 Click **Edit**.  
A dialog box to modify the specified queue opens.
- 5 Confirm that the printer you want to set is selected in the **Connection** list.
- 6 Select the **Default Printer** check box.
- 7 Confirm the settings, and click **OK**.

## ■ Specifying the Printing Options

You can specify the printing options such as the color mode or 2-sided printing.

### • For Red Hat Enterprise Linux 4 WS/5 Client

- 1 Open the URL "**http://localhost:631**" using a web browser.
- 2 Click **Manage Printers**.
- 3 Click **Configure Printer** of the queue for which you want to specify the printing options.
- 4 Enter **root** as the user name, and enter the administrator password.
- 5 Specify the required settings, and click **Continue**.  
The message **Printer xxx has been configured successfully.** appears.  
The setting is complete.

### • For SUSE Linux Enterprise Desktop 10

- 1 Open a web browser.
- 2 Enter **http://localhost:631/admin** in **Location**, and press the **Enter** key.
- 3 Enter **root** as the user name, and enter the administrator password.  
The **CUPS** window appears.

#### NOTE:

- Set the password for authority as the printer administrator before setting the printer queue. If you have not set it, go to "[Setting the Password for Authority as the Printer Administrator](#)" on page 90.
- 4 Click **Manage Printers**.
  - 5 Specify the required settings, and click **Continue**.  
The message **Printer xxx has been configured successfully.** appears.  
The setting is complete. Execute printing from the application.

## • For SUSE Linux Enterprise Desktop 11

- 1 Open a web browser.
- 2 Enter **http://localhost:631/admin** in **Location**, and press the **Enter** key.
- 3 Enter **root** as the user name, and enter the administrator password.  
The **CUPS** window appears.

### NOTE:

- Set the password for authority as the printer administrator before setting the printer queue. If you have not set it, go to "[Setting the Password for Authority as the Printer Administrator](#)" on page 90.

- 4 Click **Manage Printers**.
- 5 Specify the required settings, and click **Continue**.  
The message **Printer xxx has been configured successfully** appears.  
The setting is complete. Execute printing from the application.

## ■ Setting the Password for Authority as the Printer Administrator

For SUSE Linux Enterprise Desktop 10 and 11, you must set the password for authority as the printer administrator to do operations as the printer administrator.

### • For SUSE Linux Enterprise Desktop 10

- 1 Select **Computer** → **More Applications...** and select **Konsole** on the Application Browser.
- 2 Enter the following command in the terminal window.

```
su
(Enter the administrator password)
lppasswd -g sys -a root
(Enter the password for authority as the printer administrator
after the Enter password prompt.)
(Reenter the password for authority as the printer administrator
after the Enter password again prompt.)
```

### • For SUSE Linux Enterprise Desktop 11

- 1 Select **Computer** → **More Applications...** and select **GNOME Terminal** on the Application Browser.
- 2 Enter the following command in the terminal window.

```
su
(Enter the administrator password)
lppasswd -g sys -a root
(Enter the password for authority as the printer administrator
after the Enter password prompt.)
(Reenter the password for authority as the printer administrator
after the Enter password again prompt.)
```

## ■ Uninstalling the Print Driver

### • For Red Hat Enterprise Linux 4 WS/5 Client

- 1 Select **Applications** → **System Tools** → **Terminal**.
- 2 Enter the following command in the terminal window to delete the print queue.

```
su
(Enter the administrator password)
/usr/sbin/lpadmin -x (Enter the print queue name)
```

- 3 Repeat the command above for all queues for the same model.
- 4 Enter the following command in the terminal window.

```
su
(Enter the administrator password)
rpm -e Fuji_Xerox-DocuPrint_CP305_d
```

The print driver is uninstalled.

### • For SUSE Linux Enterprise Desktop 10

- 1 Select **Computer** → **More Applications...** and select **Konsole** on the Application Browser.
- 2 Enter the following command in the terminal window to delete the print queue.

```
su
(Enter the administrator password)
/usr/sbin/lpadmin -x (Enter the print queue name)
```

- 3 Repeat the command above for all queues for the same model.
- 4 Enter the following command in the terminal window.

```
su
(Enter the administrator password)
rpm -e Fuji_Xerox-DocuPrint_CP305_d
```

The print driver is uninstalled.



## • For SUSE Linux Enterprise Desktop 11

- 1 Select **Computer** → **More Applications...** and select **GNOME Terminal** on the Application Browser.
- 2 Enter the following command in the terminal window to delete the print queue.

```
su  
(Enter the administrator password)  
/usr/sbin/lpadmin -x (Enter the print queue name)
```

- 3 Repeat the command above for all queues for the same model.
- 4 Enter the following command in the terminal window.

```
su  
(Enter the administrator password)  
rpm -e Fuji_Xerox-DocuPrint_CP305_d
```

The print driver is uninstalled.

# Printing Basics

This chapter includes:

- ["About Print Media" on page 94](#)
- ["Supported Print Media" on page 98](#)
- ["Loading Print Media" on page 103](#)
- ["Setting Paper Sizes and Types" on page 114](#)
- ["Printing" on page 117](#)
- ["Printing With Web Services on Devices \(WSD\)" on page 138](#)

# About Print Media

---

This section includes:

- ["Print Media Usage Guidelines" on page 95](#)
- ["Print Media That Can Damage Your Printer" on page 96](#)
- ["Print Media Storage Guidelines" on page 97](#)

Using paper that is not appropriate for the printer can cause paper jams, image quality problems, or printer failure. To achieve the best performance from your printer, we recommend you to use only the paper described in this section.

When using paper other than that recommended, contact the Fuji Xerox local representative office or an authorised dealer.

## ■ Print Media Usage Guidelines

The printer tray accommodates most sizes and types of paper and other specialty media. Follow these guidelines when loading paper and media in the tray:

- Envelopes can be printed from the single sheet feeder (SSF) and standard 250-sheet tray.
- Fan paper or other specialty media before loading in the paper tray.
- Do not print on label stock once a label has been removed from a sheet.
- Use only paper envelopes. Do not use envelopes with windows, metal clasps, or adhesives with release strips.
- Print all envelopes single-sided only.
- Some wrinkling and embossing may occur when printing envelopes.
- Do not overload the paper tray. Do not load print media above the fill line on the inside of the paper width guides.
- Adjust the paper width guides to fit the paper size.
- If excessive jams or wrinkles occur, use paper or other media from a new package.



### **WARNING:**

- **Do not use conductive paper such as origami paper, carbonic paper or conductively-coated paper. When paper jam occurs, it may cause short-circuit and eventually a fire accident.**

### **See also:**

- ["Loading Print Media in the Standard 250-Sheet Tray and the Optional 250-Sheet Feeder" on page 105](#)
- ["Loading Envelope in the Standard 250-Sheet Tray" on page 107](#)
- ["Loading Print Media in the Single Sheet Feeder \(SSF\)" on page 110](#)
- ["Loading Envelope in the Single Sheet Feeder \(SSF\)" on page 111](#)
- ["Printing on Custom Size Paper" on page 133](#)

## ■ Print Media That Can Damage Your Printer

The following paper types are not recommended for use with the printer:

- Chemically treated paper used to make copies without carbon paper, also known as carbonless paper, carbonless copy paper (CCP), or no carbon required (NCR) paper.
- Preprinted paper with chemicals that may contaminate the printer.
- Preprinted paper that can be affected by the temperature in the fuser unit.
- Preprinted paper that requires a registration (the precise print location on the page) greater than  $\pm 0.09$  inches, such as optical character recognition (OCR) forms.  
In some cases, you can adjust registration with your software program to successfully print on these forms.
- Coated paper (erasable bond), synthetic paper, and thermal paper.
- Rough-edged, rough or heavily textured surface paper, or curled paper.
- Recycled paper containing more than 25% post-consumer waste that does not meet DIN 19 309.
- Multiple-part forms or documents.
- Print quality may deteriorate (blank spaces or blotches may appear in the text) when you print on talc or acid paper.



### **WARNING:**

- **Do not use conductive paper such as origami paper, carbonic paper or conductively-coated paper. When paper jam occurs, it may cause short-circuit and eventually a fire accident.**

## ■ Print Media Storage Guidelines

For proper print media storage, the following guidelines will help to avoid media feeding problems and uneven print quality.

- Store print media in an environment where the temperature is approximately 70 °F/21 °C and the relative humidity is 40%.
- Store print media in dark, cool, relatively dry locations. Most paper items are susceptible to damage from ultraviolet (UV) and visible light. UV radiation, which is emitted by the sun and fluorescent bulbs, is particularly damaging to paper items. The intensity and length of exposure to visible light on paper items should be reduced as much as possible.
- Maintain constant temperatures and relative humidity.
- Avoid attics, kitchens, garages, and basements for storing print media.
- Store print media flat. Print media should be stored on pallets, cartons, shelves, or in cabinets.
- Avoid having food or drinks in the area where print media is stored or handled.
- Do not open sealed packages of paper until you are ready to load them into the printer. Leave paper in the original packaging. For most commercial cut-size grades, the ream wrapper contains an inner lining that protects the paper from moisture loss or gain.
- Leave the media inside the bag until you are ready to use it; reinsert unused media in the bag and reseal it for protection. Some specialty media is packaged inside resealable plastic bags.
- Do not place anything on top of the print media packages.

# Supported Print Media

---

Using unsuitable print media may lead to paper jams, poor print quality, breakdown and damage to your printer. To use the features of this printer effectively, use the suggested print media that is recommended here.

## **IMPORTANT:**

- The toner may come off the print media, if it gets wet by water, rain, steam and so on. For details, contact the Fuji Xerox local representative office or an authorised dealer.

## ■ Print Media Dimensions

The maximum dimensions of print media that the standard 250-sheet tray and SSF can handle are:

- Width: 76.2 mm (3.00 inches) to 215.9 mm (8.5 inches)
- Length: 127 mm (5.00 inches) to 355.6 mm (14.00 inches)

The maximum dimensions of print media that the optional 250-sheet feeder can handle are:

- Width: 148 mm (5.83 inches) to 215.9 mm (8.5 inches)
- Length: 210 mm (8.27 inches) to 355.6 mm (14.00 inches)



## ■ Usable Print Media

The types of print media that can be used on this printer are as follows:

### Single Sheet Feeder (SSF)

---

<b>Paper Size</b>	A4 SEF (210 × 297 mm) A5 SEF (148 × 210 mm) B5 SEF (182 × 257 mm) Letter SEF (8.5 × 11 inches) Folio SEF (8.5 × 13 inches) Legal SEF (8.5 × 14 inches) Executive SEF (7.25 × 10.5 inches) Com-10 SEF (4.125 × 9.5 inches) Monarch Envelope SEF (3.875 × 7.5 inches) DL Envelope SEF (110 × 220 mm) C5 Envelope SEF (162 × 229 mm) Custom Size: Width: 76.2–215.9 mm (3–8.5 inches) Length: 127–355.6 mm (5–14 inches)
<b>Paper Type (Weight)</b>	Plain Plain Paper Light Lightweight Cardstock Heavyweight Cardstock Envelope Letterhead Lightweight Glossy Cardstock Heavyweight Glossy Cardstock Hole Punched Colored Special
<b>Loading Capacity</b>	1 sheet of standard paper

---

# Standard 250-Sheet Tray

---

<b>Paper Size</b>	A4 SEF (210 × 297 mm) A5 SEF (148 × 210 mm) B5 SEF (182 × 257 mm) Letter SEF (8.5 × 11 inches) Folio SEF (8.5 × 13 inches) Legal SEF (8.5 × 14 inches) Executive SEF (7.25 × 10.5 inches) Com-10 SEF (4.125 × 9.5 inches) Monarch Envelope SEF (3.875 × 7.5 inches) Monarch Envelope LEF (7.5 × 3.8 inches) DL Envelope SEF (110 × 220 mm) DL Envelope LEF (220 × 110 mm) C5 Envelope SEF (162 × 229 mm) Custom Size: Width: 76.2–215.9 mm (3–8.5 inches)* <sup>1</sup> Length: 127–355.6 mm (5 –14 inches)* <sup>2</sup>
<b>Paper Type (Weight)</b>	Plain Plain Paper Light Lightweight Cardstock Heavyweight Cardstock Envelope Labels Label Thick Letterhead Hole Punched Colored Special
<b>Loading Capacity</b>	250 sheets of standard paper

---

\*1: Maximum width 220 mm for envelope (DL LEF)  
DL and Monarch can be supported by LEF with flap opened.  
\*2: Minimum length 98.4 mm for envelope (Monarch LEF)

---

## Optional 250-Sheet Feeder

<b>Paper Size</b>	A4 SEF (210 × 297 mm)
	A5 SEF (148 × 210 mm)
	B5 SEF (182 × 257 mm)
	Letter SEF (8.5 × 11 inches)
	Folio SEF (8.5 × 13 inches)
	Legal SEF (8.5 × 14 inches)
	Executive SEF (7.25 × 10.5 inches)
<b>Paper Type (Weight)</b>	Plain
	Plain Paper Light
	Letterhead
	Hole Punched
	Colored
<b>Loading Capacity</b>	250 sheets of standard paper

### NOTE:

- SEF and LEF indicate the paper feed direction; SEF stands for short-edge feed. LEF stands for long-edge feed.

### See also:

- ["Loading Print Media in the Standard 250-Sheet Tray and the Optional 250-Sheet Feeder" on page 105](#)
- ["Loading Envelope in the Standard 250-Sheet Tray" on page 107](#)
- ["Loading Letterhead in the Standard 250-Sheet Tray and the Optional 250-Sheet Feeder" on page 109](#)
- ["Loading Print Media in the Single Sheet Feeder \(SSF\)" on page 110](#)
- ["Loading Envelope in the Single Sheet Feeder \(SSF\)" on page 111](#)

Printing on print media that differs from the paper size or paper type selected on the print driver, or loading print media into an unsuitable paper tray for printing, may lead to paper jams. To ensure that printing is correctly done, select the correct paper size, paper type, and paper tray.

# Loading Print Media

---

Loading print media properly helps prevent jams and ensures trouble-free printing.

Before loading any print media, identify the recommended print side of the print media. This information is usually indicated on the print media package.

## ■ Capacity

The standard 250-sheet tray and optional 250-sheet feeder can hold:

- 250 sheets of the standard paper.

The SSF can hold:

- 1 sheet of the standard paper.

## ■ Loading Print Media in the Standard 250-Sheet Tray and the Optional 250-Sheet Feeder

### NOTE:

- To avoid paper jams, do not remove the tray while printing is in progress.
- Use only laser print media. Do not use ink jet paper in your printer.

- 1 Pull the tray out of the printer about 200 mm. Hold the tray with both hands, and remove it from the printer.

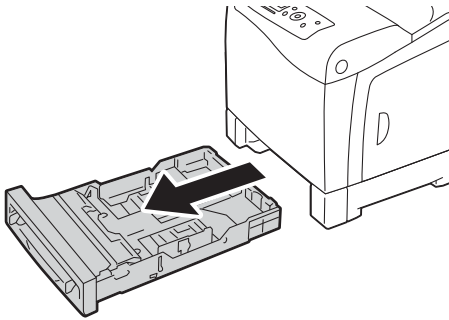

- 2 Adjust the paper guides.

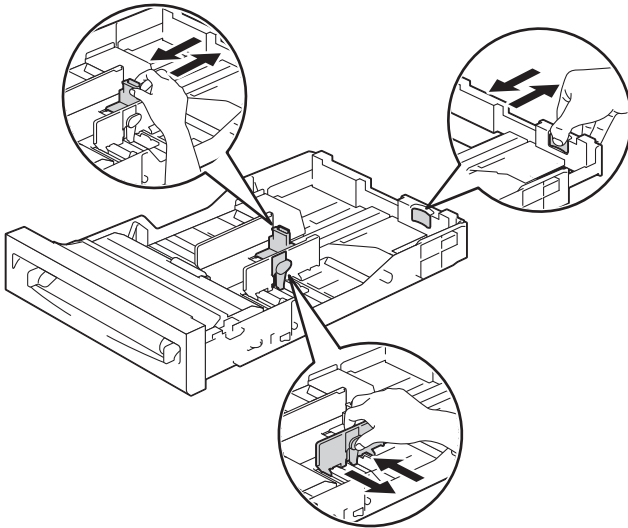

### NOTE:

- Extend the rear side of the tray when you load Legal size paper.

- 3 Before loading the print media, flex the sheets and fan them. Straighten the edges of the stack on a level surface.

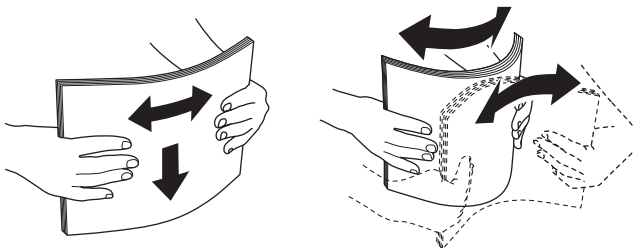

- 4 Load the print media into the tray with the recommended print side facing up.

**NOTE:**

- Do not exceed the maximum fill line in the tray. Overfilling the tray may cause paper jams.
- When loading coated paper, load coated paper one sheet at a time.

- 5 Align the width guides against the edges of the paper.

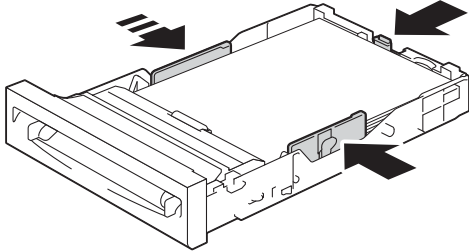

**NOTE:**

- When loading user-specified print media, adjust the width guides and slide the extendable part of the tray by pinching the length guide and sliding it until it rests lightly against the edge of the paper.

- 6 After confirming that the guides are securely adjusted, insert the tray into the printer.

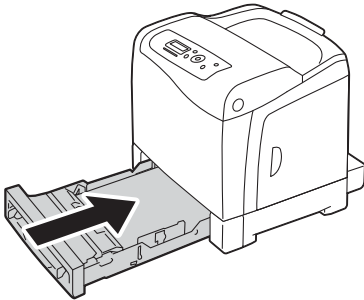

- 7 On the operator panel, select the desired paper size, and then press the **OK** button.

- 8 Select the desired paper type, and then press the **OK** button.

## Loading Envelope in the Standard 250-Sheet Tray

Use the following guidelines when loading envelopes in the standard 250-sheet tray:

### NOTE:

- If you do not load envelopes in the standard 250-sheet tray right after they have been removed from the packaging, they may bulge. To avoid jams, flatten them as shown below before loading the envelopes in the tray.

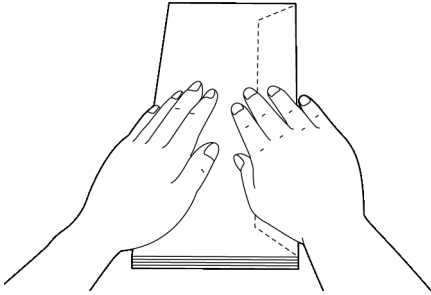

### • Com-10

Load the envelopes short edge feed with the flaps closed and the print side up. Ensure that the flaps come at the right when you face towards the printer.

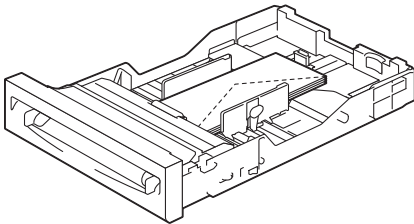



## • Monarch or DL

The Monarch or DL envelopes can be loaded in one of the following ways:

Load the envelopes short edge feed with the flaps closed and the print side up. Ensure that the flaps come at the right when you face towards the printer.

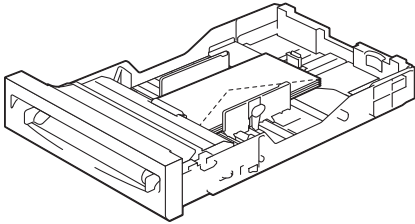

OR

Load the envelopes long edge feed with the flaps open and the print side up. Ensure that the flaps come at the top when you face towards the printer.

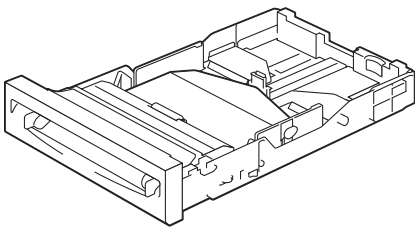

## • C5

Load the envelopes short edge feed with the flaps closed and the print side up. Ensure that the flaps come at the bottom when you face towards the printer.

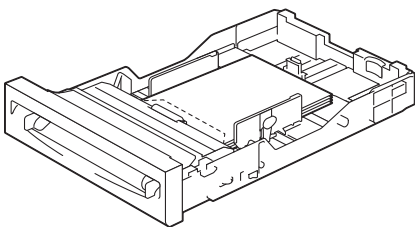

## Loading Letterhead in the Standard 250-Sheet Tray and the Optional 250-Sheet Feeder

When you use the standard 250-sheet tray and optional 250-sheet feeder, letterhead and hole punched paper enter the printer with the print side facing up.

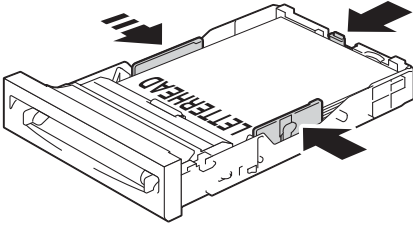

## ■ Loading Print Media in the Single Sheet Feeder (SSF)

- 1 Adjust the width guides to the print media's width.

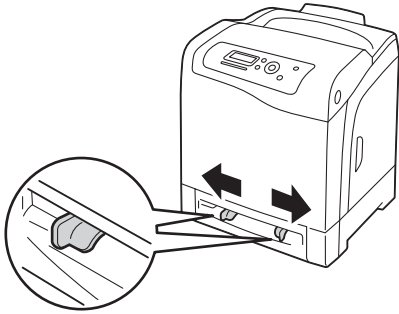

- 2 Hold both sides of the print media face down close to the SSF, and push it 8 cm to 9 cm (4 inches) into the printer until it automatically feeds.

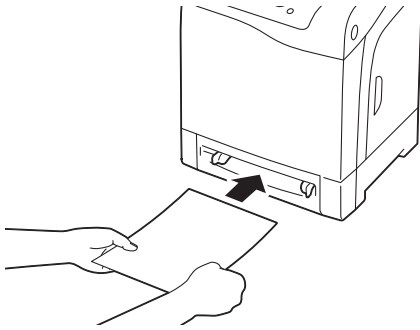

### NOTE:

- Do not force the print media into the SSF.
- Load letterhead face down, with the top of the sheet entering the printer first.
- If you experience problems with paper feed, turn the paper around.

## Loading Envelope in the Single Sheet Feeder (SSF)

### • Com-10, Monarch, or DL

To load an envelope into the SSF, insert the envelope short edge feed with the flap closed and the print side down. Ensure that the flap comes at the right when you face towards the printer.

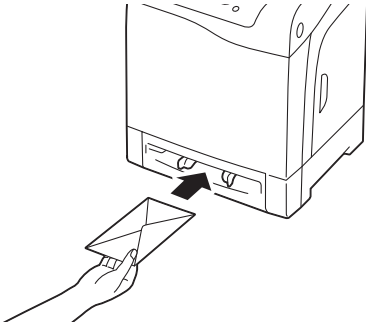

### IMPORTANT:

- Never use envelopes with windows, coated linings, or self-stick adhesives. These lead to paper jams and can cause damage to the printer.

### NOTE:

- Ensure that you load an envelope with the flap completely closed.
- Insert an envelope with the flap side face up and with the stamp area on the top right side.

## • C5

To load an envelope into the SSF, insert the envelope short edge feed with the flap open and the print side down. Ensure that the flap comes at the bottom when you face towards the printer.

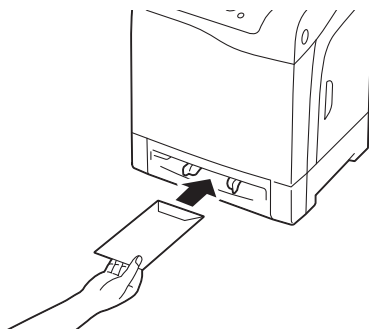
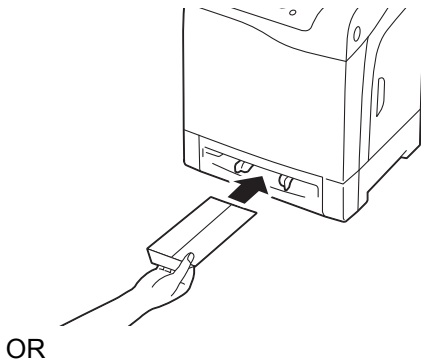

### IMPORTANT:

- Never use envelopes with windows, coated linings, or self-stick adhesives. These lead to paper jams and can cause damage to the printer.

### NOTE:

- Ensure that you load an envelope with the flap completely opened.
- Insert an envelope with the flap side face up and with the stamp area on the bottom right side.

## Loading Letterhead in the Single Sheet Feeder (SSF)

When you use the SSF letterhead enters the printer first with the print side facing down.

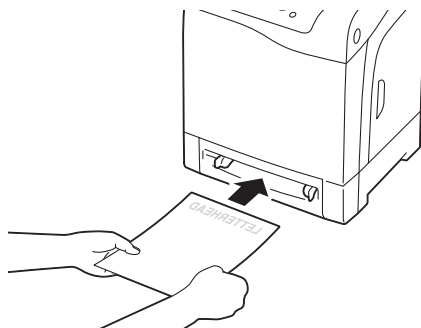

## Using the Single Sheet Feeder (SSF)

- Load only one size and type of print media during a single print job.
- To achieve the best possible print quality, use only high-quality print media that is designed for use in laser printer. For more guidelines on print media, see ["Print Media Usage Guidelines" on page 95](#).
- Do not add or remove print media when the printer is printing from the SSF. This may result in a paper jam.
- Print media should be loaded with the recommended print side down and the top of the print media going into the SSF first.
- Do not place objects on the SSF. Also, avoid pressing down or applying excessive force on it.
- The icons on the SSF show how to load the SSF with paper, and how to turn an envelope for printing.

# Setting Paper Sizes and Types

---

When loading print media in the standard 250-sheet tray and optional 250-sheet feeder, set the paper size and type on the operator panel before printing.

## **NOTE:**

- When loading print media in the SSF, use the print driver to set the paper size and type. For more information, refer to the online help of the driver.

This section describes how to set the paper size and type on the operator panel.





## **See also:**

- ["Understanding the Printer Menus" on page 142](#)

This section includes:

- ["Setting Paper Sizes" on page 115](#)
- ["Setting Paper Types" on page 116](#)

## ■ Setting Paper Sizes





- 1 On the operator panel, press the **Menu** button.
- 2 Select `Tray Settings`, and then press the  button.
- 3 Select `Tray 1` or `Tray 2`, and then press the  button.
- 4 Select `Paper Size`, and then press the  button.
- 5 Select the correct paper size for the print media loaded, and then press the  button.



## ■ Setting Paper Types

### IMPORTANT:

- Paper type settings must match those of the actual print media loaded in the tray or the feeder. Otherwise, print-quality problems can occur.

- 1 On the operator panel, press the **Menu** button.
- 2 Select `Tray Settings`, and then press the  button.
- 3 Select `Tray 1` or `Tray 2`, and then press the  button.
- 4 Select `Paper Type`, and then press the  button.
- 5 Select the correct paper type for the print media loaded, and then press the  button.

# Printing

---

This section covers how to print certain lists of information from your printer and how to cancel a job.

This section includes:

- ["Sending a Job to Print" on page 118](#)
- ["Canceling a Print Job" on page 119](#)
- ["Using the Stored Print Function" on page 120](#)
- ["Printing PDF Files Using PDF Bridge \(Windows Only\)" on page 122](#)
- ["Selecting Printing Options" on page 126](#)
- ["Printing Custom Size Paper" on page 132](#)
- ["Auditron" on page 134](#)
- ["Checking Status of Print Data" on page 135](#)
- ["Printing a Report Page" on page 136](#)
- ["Printer Settings" on page 137](#)

## ■ Sending a Job to Print

To support all of the printer features, use the print driver. When you choose **Print** from a software program, a window representing the print driver opens. Select the appropriate settings for the specific job that you are sending to print. Print settings selected from the driver override the default menu settings selected from the operator panel.

You may need to click **Preferences** from the initial **Print** box to see all of the available system settings you can change. If you are not familiar with a feature in the print driver window, open the online Help for more information.

To print a job from a typical Microsoft® Windows® application:

- 1 Open the file you want to print.
- 2 From the **File** menu, select **Print**.
- 3 Verify that the correct printer is selected in the dialog box. Modify the system settings as appropriate (such as the pages you want to print or the number of copies).
- 4 Click **Preferences** to adjust system settings that are not available from the first screen, and then click **OK**.
- 5 Click **OK** or **Print** to send the job to the selected printer.

## ■ Canceling a Print Job

There are several methods for canceling a job.

This section includes:

- ["Canceling a Job From the Operator Panel" on page 119](#)
- ["Canceling a Job From the Computer Running Windows" on page 119](#)

### Canceling a Job From the Operator Panel

To cancel a job after it has started printing:

- 1 Press the **Stop** button.
- 2 From `Active Jobs`, select `Print`, and then press the **Stop** button.  
Printing is canceled only for the current job. All the following jobs will continue to print.

### Canceling a Job From the Computer Running Windows

#### • Canceling a Job From the Taskbar

When you send a job to print, a small printer icon appears in the bottom right corner of the taskbar.

- 1 Double-click the printer icon.  
A list of print jobs appears in the printer window.
- 2 Select the job you want to cancel.
- 3 Press **Delete** key on the keyboard.

#### • Canceling a Job From the Desktop

- 1 Click **start** → **Printers and Faxes** (for Windows XP).  
Click **Start** → **Printers and Faxes** (for Windows Server 2003).  
Click **Start** → **Devices and Printers** (for Windows 7 and Windows Server 2008 R2).  
Click **Start** → **Control Panel** → **Hardware and Sound** → **Printers** (for Windows Vista).  
Click **Start** → **Control Panel** → **Printers** (for Windows Server 2008).
- 2 Double-click the printer that you selected when you sent the job for print.  
A list of print jobs appears in the printer window.
- 3 Select the job you want to cancel.
- 4 Press **Delete** key on the keyboard.

## ■ Using the Stored Print Function

When you send a job to the printer, you can specify in the driver that you want the printer to store the job in the memory. When you are ready to print the job, go to the printer and use the operator panel menus to identify which job in the memory you want to print.

The stored print function includes the following job types:

- [Secure Print](#)
- [Sample Print](#)

### NOTE:

- Stored Print function is available when:
  - The optional memory module is installed.
  - The RAM disk is enabled in the operator panel menu.
  - **RAM Disk** is set to **Available** in the print driver.
- The data in memory is cleared when the printer is turned off.

## Secure Print

You can store print jobs temporarily in printer memory and print them later from the operator panel. This feature can be used to print confidential documents. A stored print job will be deleted after you print it or at a designated time.

### NOTE:

- Secure Print is available when you use the PCL driver.
- Secure Print requires specifying a password for confidentiality.

## Sample Print

When you specify multiple copies for a collated job, this feature allows you to print only the first set for checking, before proceeding to print the remaining copies at the printer. You can select whether the remaining data is printed or deleted.

### NOTE:

- If a print job is too large for the memory available, the print may display error messages.
- If a document name is not assigned to your print job in the print driver, the job's name will be identified using the printer's time and date of submission to distinguish it from other jobs you have stored under your name.
- Sample Print is available when you use the PCL driver.

## Storing Print Jobs

In the print driver, you can specify a setting that enables you to store print jobs in temporary memory. For example, select a job type other than **Normal Print** in the **Paper / Output** tab of the PCL 6 driver. The job will be stored in temporary memory until you request to print it from the operator panel or turn off the printer.

## Printing the Stored Jobs

Once jobs are stored, you can use the operator panel to specify printing. Select the job type you are using from Secure Print and Sample Print. Then, select your user ID from a list. Secure Print requires the password you specified in the driver when you sent the job.

To print the stored documents, use the procedure below.

- 1 Press the ◀ button.
- 2 Select `Secure Print` or `Sample Print`, and then press the **OK** button.
- 3 Select your user ID, and then press the **OK** button.
- 4 Select the document you want to print, and then press the **OK** button.
- 5 Select the desired job type, and then press the **OK** button.
- 6 Select `Use PC Settings` or `Input Number`, and then press the **OK** button.

### NOTE:

- When you select `Input Number`, you can specify the number of copies to be printed before pressing the **OK** button.

The stored document will be printed.

## Specifying Your Password on the Operator Panel (Secure Print)

When you select your user ID for Secure Print, the following prompt appears:

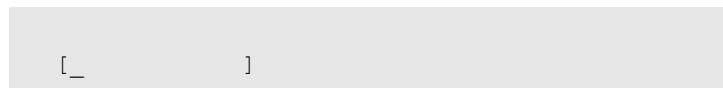

Use the buttons on the operator panel to enter the numeric password you specified in the print driver. The password you entered will be displayed as asterisks (\*\*\*\*\*) to ensure confidentiality.

If you enter an invalid password, the message "Wrong password Re-enter" appears. Wait three seconds, or press the **OK** button to return to the screen for user selection.

When you enter a valid password, you have access to all print jobs matching the user name and password you entered. The print jobs matching the password you entered appear on the screen. You can then choose to print or to delete jobs matching the password you entered. (See "[Printing the Stored Jobs](#)" for more information.)

## Deleting Stored Jobs

With Secure Print, a job that has been stored will be deleted after printing if entered on the operator panel or at turning off the printer.

For Sample Print, these jobs remain stored until you delete them on the operator panel or turn off the printer.

## ■ Printing PDF Files Using PDF Bridge (Windows Only)

The printer has the PDF Bridge feature, which enables you to print PDF files directly without a print driver. Printing PDF files without a print driver is much easier and faster when compared to printing with a print driver. This section describes how to print PDF files using PDF Bridge.

This section includes:

- ["Supported PDF Files" on page 122](#)
- ["Using the ContentsBridge Utility" on page 122](#)
- ["Using the Commands" on page 123](#)

### Supported PDF Files

PDF files created on the following versions of Adobe Acrobat can be printed using PDF Bridge.

- Adobe Acrobat 5.X (excluding some of the features added to PDF1.4)
- Adobe Acrobat 6.X (excluding some of the features added to PDF1.5)
- Adobe Acrobat 7.X (excluding some of the features added to PDF1.6)

#### NOTE:

- Some PDF files cannot be printed depending on how they are created. In such case, open the files and print them using a print driver.

### Using the ContentsBridge Utility

The ContentsBridge Utility is software that enables direct printing of PDF files by simply dragging and dropping files onto the icon. To use the ContentsBridge Utility, refer to the manual included on the *Driver CD Kit*.

## Using the Commands

You can also print PDF files using the `lpr` or `ftp` command. When you print using these commands, the following PDF settings on the operator panel become effective.

- Quantity
- 2-Sided Print
- Print Mode
- Password
- Collated
- Output Size
- Layout
- Output Color

### NOTE:

- When you print using the `lpr` command, the print quantity must be set also using `lpr` command. In such case, the Quantity setting on the operator panel becomes invalid. If you do not specify the quantity using the `lpr` command, the printer recognizes the quantity as "1 set".
- To print PDF files using the `lpr` or `ftp` command, you must enable the printer's LPD or FTP port using the operator panel or CentreWare Internet Services (default: Enable).

### Using the `lpr` command

In the command prompt, enter the `lpr` command as described in the following example:

Example: Printing "event.pdf" when the printer's IP address is 192.168.1.100.

```
C:\> lpr -S 192.168.1.100 -P lp event.pdf
```

### Using the `ftp` command

In the command prompt, enter the `ftp` command as described in the following example:

Example: Printing "event.pdf" when the printer's IP address is 192.168.1.100.

```
C:\> ftp 192.168.1.100
Connected to 192.168.1.100.
220 FUJI XEROX DocuPrint XXXX
User (192.168.1.100:(none)):
331 Password required
Password:
230 Logged in
ftp> bin
200 Command successful
ftp> put event.pdf
200 Command successful
150 Opening data connection
226 Transfer complete
ftp: xxxxx bytes sent in xxxSeconds
xxxxxkbytes/sec.
ftp>
```



## ■ Duplex Printing

This section includes:

- ["Automatic Duplex Printing" on page 124](#)
- ["Using Booklet Print" on page 125](#)

### Automatic Duplex Printing

Automatic duplex printing (or 2-sided printing) allows you to print on both sides of a sheet of paper. A4, Letter, Folio, and Legal paper sizes are acceptable.

The following procedure uses the PCL 6 driver as an example.

- 1 Click **start** → **Printers and Faxes** (for Windows XP).  
Click **Start** → **Printers and Faxes** (for Windows Server 2003).  
Click **Start** → **Devices and Printers** (for Windows 7 and Windows Server 2008 R2).  
Click **Start** → **Control Panel** → **Hardware and Sound** → **Printers** (for Windows Vista).  
Click **Start** → **Control Panel** → **Printers** (for Windows Server 2008).

A list of available printers appears.

- 2 Right-click the printer and select **Printing Preferences**.  
The **Paper / Output** tab appears.
- 3 From **Paper Tray**, select **Tray1**, **Tray2**, or **Auto Paper Select**.
- 4 From **2 Sided Print**, select **2 Sided Print** or **2 Sided, Flip on Short Edge**.

#### NOTE:

- For details on the **2 Sided Print** and **2 Sided, Flip on Short Edge** options, see ["2 Sided Print" on page 125](#) and ["2 Sided, Flip on Short Edge" on page 125](#).

- 5 Click **OK**.

# Using Booklet Print

To use the Booklet Print feature, select **Booklet Creation** in the **Booklet / Poster / Mixed Document / Rotation** dialog box displayed by clicking the **Booklet / Poster / Mixed Document / Rotation** button in the **Layout** tab of the printer printing preferences dialog box. **2 Sided Print** binding position is selected by default. If you want to change the position, select **2 Sided, Flip on Short Edge** from the **2 Sided Print** menu in the **Paper / Output** tab of the printer printing preferences dialog box.

**NOTE:**

- To use the booklet printing, select **Tray1**, **Tray2**, or **Auto Paper Select** for **Paper Tray** in the **Paper / Output** tab. Do not select **Manual Feeder**.

---

**2 Sided Print** Assumes binding along the long edge of the page (left edge for portrait orientation and top edge for landscape orientation). The following illustration shows long-edge binding for portrait and landscape pages:

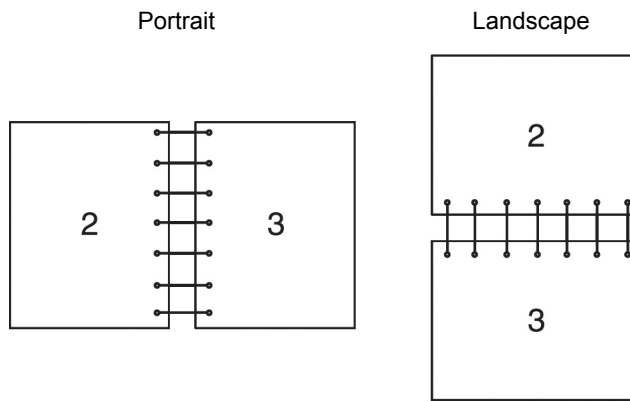

---

**2 Sided, Flip on Short Edge** Assumes binding along the short edge of the page (top edge for portrait orientation and left edge for landscape orientation). The following illustration shows short-edge binding for portrait and landscape pages:

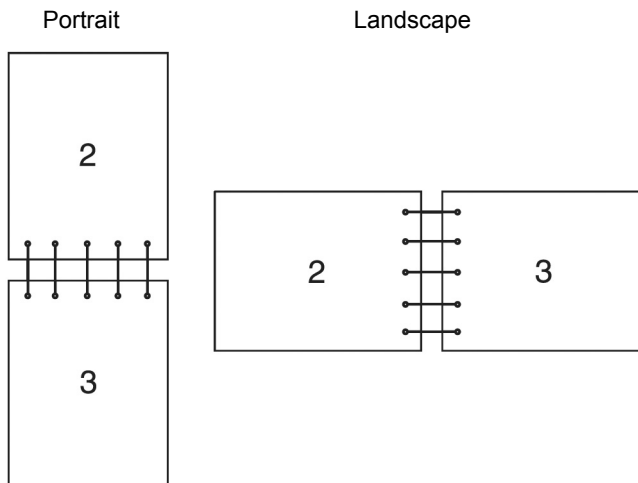

## ■ Selecting Printing Options

This section includes:

- "Selecting Printing Preferences (Windows)" on page 126
- "Selecting Options for an Individual Job (Windows)" on page 127
- "Selecting Options for an Individual Job (Mac OS X)" on page 130

### Selecting Printing Preferences (Windows)

Printer preferences control all of your print jobs, unless you override them specifically for a job. For example, if you want to use duplex printing for most jobs, set this option in printer settings.

The following procedure uses the PCL 6 driver as an example.

To select printer preferences:

- 1 Click **start** → **Printers and Faxes** (for Windows XP).  
Click **Start** → **Printers and Faxes** (for Windows Server 2003).  
Click **Start** → **Devices and Printers** (for Windows 7 and Windows Server 2008 R2).  
Click **Start** → **Control Panel** → **Hardware and Sound** → **Printers** (for Windows Vista).  
Click **Start** → **Control Panel** → **Printers** (for Windows Server 2008).  
A list of available printers appears.
- 2 Right-click the icon for your printer, and then select **Printing Preferences**.  
The **FX DocuPrint CP305 d PCL 6 Printing Preferences** screen appears.
- 3 Select the **Advanced Settings** tab, and then click **Defaults**.
- 4 Make selections on the driver tabs, and then click **OK** to save your selections.

#### NOTE:

- For more information about Windows print driver options, click **Help** on the print driver tab to view the online help.

## Selecting Options for an Individual Job (Windows)

If you want to use special printing options for a particular job, change the driver settings before sending the job to the printer. For example, if you want to use Photo print-quality mode for a particular graphic, select this setting in the driver before printing that job.

The following procedure uses the PCL 6 driver as an example.

- 1 With the desired document or graphic open in your application, access the **Print** dialog box.
- 2 Select the FX DocuPrint CP305 d PCL 6 and click **Preferences** to open the print driver.
- 3 Make selections on the driver tabs. See the following table for specific printing options.

### NOTE:

- In Windows XP, Windows Server 2003, Windows Server 2008, Windows Vista, Windows Server 2008 R2, and Windows 7, you can save current printing options with a distinctive name and apply them to other print jobs. Select either the **Paper / Output**, **Image Options**, **Layout**, **Watermarks / Forms**, or **Advanced Settings** tab, and then click **Save** on the **Paper / Output** tab. Click **Help** for more information.

- 4 Click **OK** to save your selections.
- 5 Print the job.

See the following table for specific printing options:

The table shown below uses the PCL 6 driver as an example.

### Printing Options for Windows

Operating System	Driver Tab	Printing Options
Windows XP, Windows XP x 64bit, Windows Server 2003, Windows Server 2003 x 64bit, Windows Vista, Windows Vista x 64bit, Windows Server 2008, Windows Server 2008 x 64bit, Windows Server 2008 R2, Windows 7, or Windows 7 x 64bit	<b>Paper / Output</b> tab	<ul style="list-style-type: none"> <li>• Job Type</li> <li>• Saved Settings</li> <li>• 2 Sided Print</li> <li>• Output Color</li> <li>• Quantity</li> <li>• Paper Summary</li> <li>• Paper Size</li> <li>• Paper Tray</li> <li>• Paper Type</li> <li>• Manual Feeder Feed Orientation</li> <li>• Covers / Separators</li> <li>• Envelope/Paper Setup Wizard</li> <li>• Printer Status</li> <li>• Defaults</li> </ul>
	<b>Image Options</b> tab	<ul style="list-style-type: none"> <li>• Output Color</li> <li>• Image Quality</li> <li>• Output Recognition</li> <li>• Image Adjustment Mode</li> <li>• Image Types</li> <li>• Image Auto Correction</li> <li>• Image Settings</li> <li>• Color Balance</li> <li>• Profile Settings</li> <li>• Defaults</li> </ul>
	<b>Layout</b> tab	<ul style="list-style-type: none"> <li>• Image Orientation</li> <li>• Multiple-Up</li> <li>• Booklet / Poster / Mixed Document / Rotation</li> <li>• Fit to New Paper Size</li> <li>• Specify Zoom</li> <li>• Image Shift / Print Position</li> <li>• Defaults</li> </ul>

Operating System	Driver Tab	Printing Options
Windows XP, Windows Server 2003, Windows Vista, Windows Server 2008, or Windows 7	<b>Watermarks / Forms</b> tab	<ul style="list-style-type: none"> <li>• Watermarks <ul style="list-style-type: none"> <li>– New Watermark</li> <li>– New Watermark (Bitmap)</li> <li>– Edit Watermark</li> <li>– Delete Watermark</li> <li>– Apply to First Page Only</li> </ul> </li> <li>• Forms <ul style="list-style-type: none"> <li>– No Forms</li> <li>– Create / Register Forms</li> <li>– Image Overlay</li> </ul> </li> <li>• Annotation</li> <li>• Defaults</li> </ul>
Windows XP, Windows XP x 64bit, Windows Server 2003, Windows Server 2003 x 64bit, Windows Vista, Windows Vista x 64bit, Windows Server 2008, Windows Server 2008 x 64bit, Windows Server 2008 R2, Windows 7, or Windows 7 x 64bit	<b>Advanced Settings</b> tab	<ul style="list-style-type: none"> <li>• Skip Blank Pages</li> <li>• Draft Mode</li> <li>• Banner Sheet</li> <li>• Substitute Tray</li> <li>• Other Settings (Graphics Settings) <ul style="list-style-type: none"> <li>– Items</li> <li>– Settings for</li> <li>– Paper Tray Selection Method</li> </ul> </li> <li>• Specify Font</li> <li>• About</li> <li>• Defaults</li> </ul>

## Selecting Options for an Individual Job (Mac OS X)

To select print settings for a particular job, change the driver settings before sending the job to the printer.

- 1 With the document open in your application, click **File**, and then click **Print**.
- 2 Select the desired printing options from the menus and drop-down lists that are displayed.

### NOTE:

- In Mac OS® X, click **Save as** on the **Presets** menu screen to save the current printer settings. You can create multiple presets and save each with its own distinctive name and printer settings. To print jobs using specific printer settings, click the applicable saved preset in the **Presets** list.

- 3 Click **Print** to print the job.

Mac OS X Print Driver Printing Options:

The table shown below uses Mac OS X 10.6 TextEdit as an example.

### Printing options for Mac OS X

Item	Printing Options
	<ul style="list-style-type: none"><li>• Copies</li><li>• Collated</li><li>• Pages</li><li>• Paper Size</li><li>• Orientation</li></ul>
Layout	<ul style="list-style-type: none"><li>• Pages per Sheet</li><li>• Layout Direction</li><li>• Border</li><li>• Two-Sided</li></ul>
Color Matching	<ul style="list-style-type: none"><li>• ColorSync</li><li>• Profile</li></ul>
Paper Handling	<ul style="list-style-type: none"><li>• Pages to Print</li><li>• Page Order</li><li>• Destination Paper Size</li></ul>
Paper Feed	<ul style="list-style-type: none"><li>• All pages From</li><li>• First Pages From</li><li>• Remaining From</li></ul>
Cover Page	<ul style="list-style-type: none"><li>• Print Cover Page</li><li>• Cover Page Type</li><li>• Billing Info</li></ul>
Scheduler	<ul style="list-style-type: none"><li>• Print Document</li><li>• Priority</li></ul>
Job Accounting	<ul style="list-style-type: none"><li>• Account Mode</li><li>• User Details Setup</li></ul>
Job Type	<ul style="list-style-type: none"><li>• Job Type</li><li>• Setup</li><li>• Defaults</li></ul>

Item	Printing Options
Image Options	<ul style="list-style-type: none"> <li>• Output Color</li> <li>• Image Quality</li> <li>• Brightness</li> <li>• Basic Features/Advanced Features</li> <li>• Image Type</li> <li>• Image Adjustment</li> <li>• Screen</li> <li>• Color Balance</li> <li>• Defaults</li> </ul>
Printer Features	<ul style="list-style-type: none"> <li>• Feature Sets</li> <li>• Gray Guaranteed</li> <li>• Feed Orientation</li> <li>• Paper Type</li> <li>• Substitute Tray</li> <li>• Custom Paper Auto Orientation</li> <li>• Image Enhancement</li> <li>• Draft Mode</li> <li>• Skip Blank Pages</li> <li>• Halftone Screen Lock</li> <li>• High speed for monochrome documents</li> <li>• Trapping</li> <li>• Letterhead Duplex Mode</li> </ul>
Summary	



## ■ Printing Custom Size Paper

This section explains how to print on custom size paper using the print driver.

Custom size paper can be loaded in the SSF and standard 250-sheet tray. The way to load custom size paper in the SSF is the same as the one to load standard size paper. The way to load custom size paper in the standard 250-sheet tray is the same as the one to load standard size paper.

### NOTE:

- Custom size paper cannot be loaded in the optional 250-sheet feeder.

### See also:

- ["Loading Print Media in the Single Sheet Feeder \(SSF\)" on page 110](#)
- ["Loading Print Media in the Standard 250-Sheet Tray and the Optional 250-Sheet Feeder" on page 105](#)
- ["Setting Paper Sizes and Types" on page 114](#)

## Defining Custom Paper Sizes

Before printing, set the custom size on the print driver.

### NOTE:

- When setting the paper size on the print driver and the operator panel, be sure to specify the same size as the actual print media used. Setting the wrong size for printing can cause printer failure. This is especially true if you configure a bigger size when using a narrow width paper.

### • Using the Windows Print Driver

On the Windows print driver, set the custom size in the **Custom Paper Size** dialog box. This section explains the procedure using Windows XP and the PCL 6 driver as an example.

For Windows XP or later, an administrator's password only allows users with administrator rights to change the settings. Users without the rights of administrator can only view the contents.

- 1 Click **start** → **Printers and Faxes**.
- 2 Right-click the printer, and then select **Properties**.
- 3 Select the **Configuration** tab.
- 4 Click **Custom Paper Size**.
- 5 Select the custom setup you want to define from **Details**.
- 6 Specify the length of the short edge and long edge under **Settings for**. You can specify the values either by entering them directly or using the **Up Arrow** and **Down Arrow** buttons. The length of the short edge cannot be longer than the long edge, even if it is within the specified range. The length of the long edge cannot be shorter than the short edge, even if it is within the specified range.
- 7 To assign a paper name, select the **Name Paper Size** check box, and then enter the name in **Paper Name**. Up to 14 characters can be used for the paper name.
- 8 If necessary, repeat steps 5 to 7 to define another custom size.
- 9 Click **OK** twice.

## Printing on Custom Size Paper

Use the following procedures to print using either the Windows or Mac OS X print drivers.

### • Using the Windows Print Driver

To print on custom size paper using the PCL 6 driver as an example:

#### NOTE:

- The way to display the printer **Properties** dialog box differs according to the application software. Refer to the manual of each application software.

- 1 From the **File** menu, select **Print**.
- 2 Select the printer as the printer to be used and click **Preferences**.
- 3 Select the **Paper / Output** tab.
- 4 Select the size of the original document from **Paper Size**.
- 5 Select the appropriate paper type from **Paper Type**.
- 6 Click the **Layout** tab.
- 7 From **Fit to New Paper Size**, select **Same as Paper Size**.
- 8 Click **OK**.
- 9 Click **Print** in the **Printer** dialog box to start printing.

### • Using the Mac OS X Print Driver

This section explains the procedure using Mac OS X 10.6 TextEdit as an example.

- 1 From the **File** menu, select **Page Setup**.
- 2 Select the printer as the printer to be used from **Format For**.
- 3 From **Paper Size**, select **Manage Custom Sizes**.
- 4 In the **Custom Page Sizes** window, click **+**.  
A newly created setting "Untitled" is displayed in the list.
- 5 Double-click "Untitled" and enter the name for the setting.
- 6 Enter the size of the original document in the **Width** and **Height** boxes of **Paper Size**.
- 7 Specify **Non-Printable Area** if necessary.
- 8 Click **OK**.
- 9 From the **File** menu, select **Print**.
- 10 Click **Print** in the **Print** dialog box to start printing.

## ■ Auditron

Auditron contains an authentication function that can set limits on what processes can be used, as well as an account management that can be used to control usage based on authentication.

The following illustration shows how the printer works with Auditron.

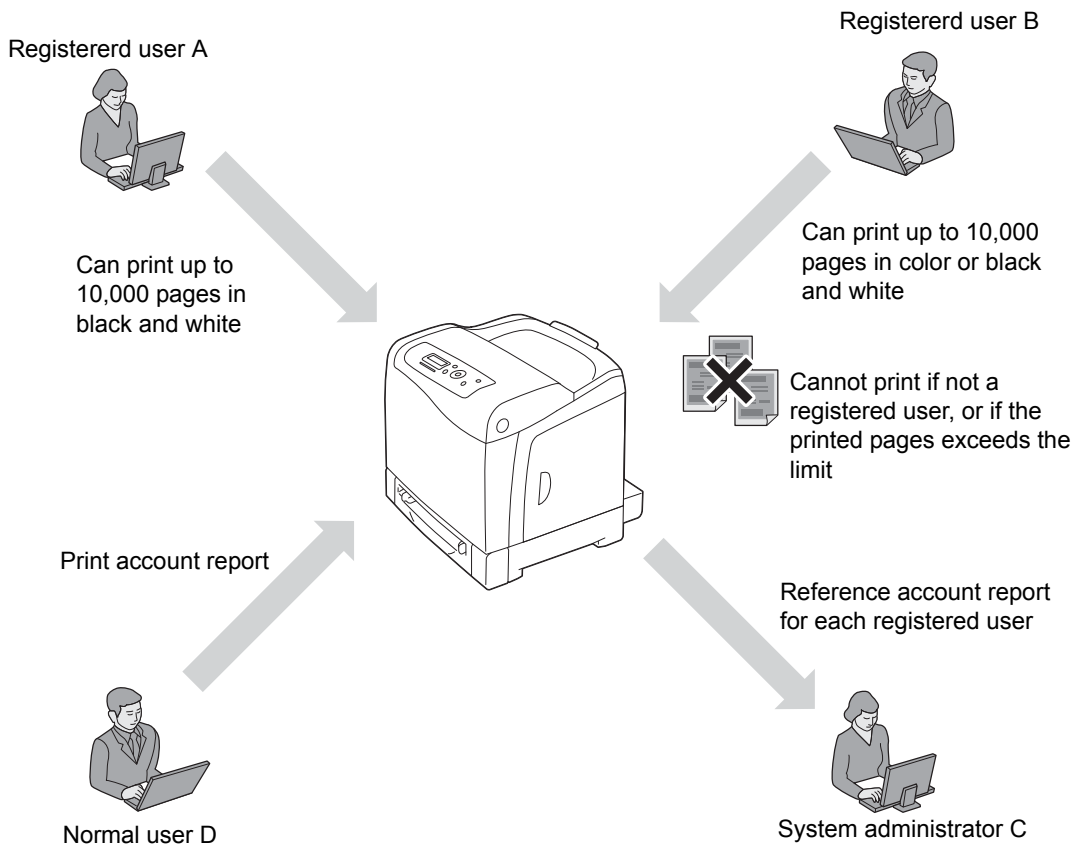

## ■ Checking Status of Print Data

This section includes:

- ["Checking Status \(Windows Only\)" on page 135](#)
- ["Checking Status in CentreWare Internet Services \(Windows & Mac OS X\)" on page 135](#)

### Checking Status (Windows Only)

Printer information and status are displayed on the SimpleMonitor window. Double-click the SimpleMonitor printer icon on the taskbar at the bottom right of the screen. From the displayed window, check the column **Status**.

You can change the display contents with the button on the left of the SimpleMonitor window.

**Status Settings** button: Displays the **Status Settings** dialog box and allows you to check the printer name, printer connection port, and printer status.

For more information about SimpleMonitor, see Help: The following procedure uses Windows XP as an example:

- 1 Click **start** → **All Programs**.
- 2 Select **Fuji Xerox**.
- 3 Select **SimpleMonitor for Asia-Pacific**.
- 4 Select **SimpleMonitor Help**.

#### See also:

- ["SimpleMonitor \(Windows Only\)" on page 55](#)

### Checking Status in CentreWare Internet Services (Windows & Mac OS X)

You can check the status of the print job sent to the printer at the **Status** tab of CentreWare Internet Services.

#### See also:

- ["Printer Management Software" on page 51](#)

## ■ Printing a Report Page



You can print a variety of settings for your printer including printer settings, panel settings, job history, error history, print meter, font list, macro list, stored document list, and demo page. This section describes how to print a report page.

### Printing a Printer Settings Page

To verify detailed printer settings, print a printer settings page. A printed printer settings page also allows you to verify whether or not options have been installed properly.

#### See also:

- ["Understanding the Printer Menus" on page 142](#)

- 1 Press the **Menu** button.
- 2 Select `Report/List`, and then press the  button.
- 3 Select `Printer Settings`, and then press the  button.  
The printer settings page is printed.

If any message appears when you print this page, see the online **Help** for more information.

## ■ Printer Settings

You can select menu items and corresponding values from the operator panel.

When you first browse through the menus from the operator panel, you see some menu items marked with an asterisk (\*).

These items are the factory default and original system settings.



### NOTE:

- Factory defaults may vary for different countries.

When you select a new setting from the operator panel, the item selected is marked with an asterisk (\*) to identify it as the current user default menu setting.



These settings are active until new ones are selected or the factory defaults are restored.

To select a new value as a setting:

- 1 Press the **Menu** button.
- 2 Select the desired menu, and then press the  button.
- 3 Select the desired menu or menu item, and then press the  button.
  - If the selection is a menu, the menu is opened and the first system setting in the menu appears.
  - If the selection is a menu item, the default menu setting for the menu item appears. (The current user default menu setting is marked with an asterisk (\*).)

Each menu item has a list of values for the menu item. A value can be:

- A phrase or word to describe a setting
- A numerical value that can be changed
- An On or Off setting

- 4 Select the desired value, and then press the  button.
- 5 Press the  (**Back**) or  button to return to the previous menu.

To continue setting other items, select the desired menu. To quit setting new values, press the  (**Back**) button.

Driver settings may override changes previously made and may require you to change the operator panel defaults.

# Printing With Web Services on Devices (WSD)

---

This section provides information for network printing with WSD, the new Microsoft protocol for Microsoft Windows Vista, Windows Server 2008, Windows Server 2008 R2, and Windows 7.

This section includes:

- ["Adding Roles of Print Services" on page 139](#)
- ["Printer Setup" on page 140](#)

## ■ Adding Roles of Print Services

When you use Windows Server 2008 or Windows Server 2008 R2, you need to add the roles of print services to the Windows Server 2008 or Windows Server 2008 R2 client.

### • For Windows Server 2008:

- 1 Click **Start**→ **Administrative Tools**→ **Server Manager**.
- 2 Select **Add Roles** from the **Action** menu.
- 3 Select the **Print Services** check box on the **Server Roles** window in the **Add Roles Wizard**, and then click **Next**.
- 4 Click **Next**.
- 5 Select the **Print Server** check box, and then click **Next**.
- 6 Click **Install**.

### • For Windows Server 2008 R2:

- 1 Click **Start**→ **Administrative Tools**→ **Server Manager**.
- 2 Select **Add Roles** from the **Action** menu.
- 3 Select the **Print and Document Services** check box on the **Server Roles** window in the **Add Roles Wizard**, and then click **Next**.
- 4 Click **Next**.
- 5 Select the **Print Server** check box, and then click **Next**.
- 6 Click **Install**.



## ■ Printer Setup

You can install your new printer on the network using the *Driver CD Kit* that shipped with your printer, or using Microsoft Windows' **Add Printer** wizard. The following procedure uses the PCL 6 driver as an example.

### Installing a Print Driver Using the Add Printer Wizard

- 1 Click **Start**→ **Control Panel**→ **Hardware and Sound**→ **Printers** (**Start**→ **Devices and Printers** for Windows Server 2008 R2 and Windows 7).
- 2 Click **Add a printer** to launch the **Add Printer** wizard.
- 3 Select **Add a network, wireless or Bluetooth printer**.
- 4 In the list of available printers, select the one you want to use, and then click **Next**.

#### NOTE:

- In the list of available printers, the WSD printer is displayed in the form of **http://IP address/ws/**.
  - If no WSD printer is displayed in the list, enter the printer's IP address manually to create a WSD printer. To enter the printer's IP address manually, follow the instructions below. For Windows Server 2008 R2, to create a WSD printer, you must be a member of Administrators group.
    - 1 Click **The printer that I want isn't listed**.
    - 2 Select **Add a printer using a TCP/IP address or hostname** and click **Next**.
    - 3 Select **Web Services Device** from **Device type**.
    - 4 Enter the printer's IP address in **Hostname or IP address** and click **Next**.
  - Before installing the driver using the **Add Printer** wizard on Windows Server 2008 R2 or Windows 7, perform one of the following:
    - Establish the Internet connection so that Windows Update can scan your computer.
    - Add the print driver to your computer.
- 5 If prompted, install the print driver on your computer. If you are prompted for an administrator password or confirmation, enter the password or provide confirmation.
  - 6 Complete the additional steps in the wizard, and then click **Finish**.
  - 7 Print a test page to verify print installation.
    - a Click **Start**→ **Control Panel**→ **Hardware and Sound**→ **Printers** (**Start**→ **Devices and Printers** for Windows Server 2008 R2 and Windows 7).
    - b Right-click the printer you just created, and then click **Properties** (**Printer properties** for Windows Server 2008 R2 and Windows 7).  
On the **Options** tab, set each setting item, and then click **Apply**.
    - c On the **General** tab, click **Print Test Page**. When a test page prints successfully, installation is complete.

# Using the Operator Panel Menus

This chapter includes:

- ["Understanding the Printer Menus" on page 142](#)
- ["Panel Lock Function" on page 173](#)
- ["Setting the Power Saver Time Option" on page 176](#)
- ["Resetting to Factory Defaults" on page 177](#)

# Understanding the Printer Menus

---

When your printer is connected to a network and available to a number of users, the access to the `Admin Menu` can be limited. This prevents other users from using the operator panel to inadvertently change a user default that has been set by the administrator.

However, you can use your print driver to override user defaults and select settings for individual print jobs.

## ■ Report/List

Use the `Report/List` menu to print various types of reports and lists.

### Printer Settings

**Purpose:**

To print a list of the current user default values, the installed options, the amount of installed print memory, and the status of printer supplies.

### Panel Settings

**Purpose:**

To print a detailed list of all the settings on the operator panel menus.

### PCL Fonts List

**Purpose:**

To print a sample of the available PCL fonts.

### PCL Macro List

**Purpose:**

To print the information on the downloaded PCL macro.

### PS Fonts List

**Purpose:**

To print a sample of the available PS fonts.

### PDF Fonts List

**Purpose:**

To print a sample of the available PDF fonts.

### Job History

**Purpose:**

To print a detailed list of the print jobs that have been processed. This list contains the last 20 jobs.

### Error History

**Purpose:**

To print a detailed list of paper jams and fatal errors.

### Print Meter

**Purpose:**

To print the reports for the total number of pages printed.

## Demo Page

**Purpose:**

To print a page for testing colors.

## Stored Documents

**NOTE:**

- Stored Documents feature is available only when the 512 MB optional memory module is installed on the printer and RAM Disk under System Settings is enabled.

**Purpose:**

To print a list of all files stored for Secure Print and Sample Print in the RAM disk.

## ■ Meter Readings

### Purpose:

To check the total number of printed pages.

### Values:

<b>Meter 1</b>	Displays the total number of color prints.
<b>Meter 2</b>	Displays the total number of monochrome prints.
<b>Meter 3</b>	Displays the total number of large size color prints.
<b>Meter 4</b>	Displays the total number of color and monochrome prints (Meter 1 + Meter 2).

## ■ Admin Menu

Use the `Admin Menu` menu to configure a variety of printer features.

## PCL Settings

Use the `PCL Settings` menu to change printer settings that only affect jobs using the PCL emulation printer language.

### NOTE:

- Values marked by an asterisk (\*) are the factory default menu settings.

### • Paper Tray

#### Purpose:

To specify the default paper tray.

#### Values:

Auto*
Tray 1
Tray 2 <sup>*1</sup>
Manual Feed

<sup>\*1</sup> Tray 2 is available only when the optional 250-sheet feeder is installed.

## • Output Size

### Purpose:

To specify the default paper size.

### Values:

#### mm series

<b>A4 - 210x297*<sup>1</sup></b>			
<b>A5 - 148x210</b>			
<b>B5 - 182x257</b>			
<b>Letter - 8.5x11</b>			
<b>US Folio-8.5x13</b>			
<b>Legal - 8.5x14</b>			
<b>Executive</b>			
<b>Monarch Env.</b>			
<b>DL Env - 110x220</b>			
<b>C5 Env - 162x229</b>			
<b>#10Env - 4.1x9.5</b>			
<b>New Custom Size</b>	<b>Portrait (Y)</b>	297 mm* 127 - 355 mm	Specifies the length of the custom size paper.
	<b>Landscape (X)</b>	210 mm* 77 - 215 mm	

<sup>\*1</sup> The default for `Output Size` varies depending on country-specific factory.

#### inch series

<b>Letter - 8.5x11*<sup>1</sup></b>			
<b>US Folio-8.5x13</b>			
<b>Legal - 8.5x14</b>			
<b>A4 - 210x297</b>			
<b>A5 - 148x210</b>			
<b>B5 - 182x257</b>			
<b>Executive</b>			
<b>Monarch Env.</b>			
<b>DL Env- 110x220</b>			
<b>C5 Env- 162x229</b>			
<b>#10Env- 4.1x9.5</b>			
<b>New Custom Size</b>	<b>Portrait (Y)</b>	11.7 inch* 5.0-14.0 inches	Specifies the length of the custom size paper.
	<b>Landscape (X)</b>	8.3 inch* 3.0-8.5 inches	

<sup>\*1</sup> The default for `Output Size` varies depending on country-specific factory.

### NOTE:

- Selecting a custom size for the paper size prompts you to enter a custom length and width.



## • Orientation

### Purpose:

To specify how text and graphics are oriented on the page.

### Values:

<b>Portrait*</b>	Prints text and graphics parallel to the short edge of the paper.
<b>Landscape</b>	Prints text and graphics parallel to the long edge of the paper.

## • 2-Sided

### Purpose:

To specify whether to print on both sides of a sheet of paper.

### Values:

<b>2-Sided Print</b>	<b>Off*</b>	Does not print on both sides of a sheet of paper.
	<b>On</b>	Prints on both sides of a sheet of paper.
<b>Binding Edge</b>	<b>Long Edge Flip*</b>	Prints on both sides of a sheet of paper to be bound by long edge.
	<b>Short Edge Flip</b>	Prints on both sides of a sheet of paper to be bound by short edge.

## • Font

### Purpose:

To specify the default font from the fonts registered in the printer.

### Values:

<b>CG Times</b>	<b>LetterGothic</b>	<b>CourierPS</b>
<b>CG Times It</b>	<b>LetterGothic It</b>	<b>CourierPS Ob</b>
<b>CG Times Bd</b>	<b>LetterGothic Bd</b>	<b>CourierPS Bd</b>
<b>CG Times BdIt</b>	<b>Albertus Md</b>	<b>CourierPS BdOb</b>
<b>Univers Md</b>	<b>Albertus XBd</b>	<b>SymbolPS</b>
<b>Univers MdIt</b>	<b>Clarendon Cd</b>	<b>Palatino Roman</b>
<b>Univers Bd</b>	<b>Coronet</b>	<b>Palatino It</b>
<b>Univers BdIt</b>	<b>Marigold</b>	<b>Palatino Bd</b>
<b>Univers MdCd</b>	<b>Arial</b>	<b>Palatino BdIt</b>
<b>Univers MdCdIt</b>	<b>Arial It</b>	<b>ITCBookman Lt</b>
<b>Univers BdCd</b>	<b>Arial Bd</b>	<b>ITCBookman LtIt</b>
<b>Univers BdCdIt</b>	<b>Arial BdIt</b>	<b>ITCBookmanDm</b>
<b>AntiqueOlv</b>	<b>Times New</b>	<b>ITCBookmanDm It</b>
<b>AntiqueOlv It</b>	<b>Times New It</b>	<b>HelveticaNr</b>
<b>AntiqueOlv Bd</b>	<b>Times New Bd</b>	<b>HelveticaNr Ob</b>
<b>CG Omega</b>	<b>Times New BdIt</b>	<b>HelveticaNr Bd</b>
<b>CG Omega It</b>	<b>Symbol</b>	<b>HelveticaNrBdOb</b>
<b>CG Omega Bd</b>	<b>Wingdings</b>	<b>N C Schbk Roman</b>
<b>CG Omega BdIt</b>	<b>Line Printer</b>	<b>N C Schbk It</b>

GaramondAntiqua	Times Roman	N C Schbk Bd
Garamond Krsv	Times It	N C Schbk Bdl
Garamond Hlb	Times Bd	ITC A G Go Bk
GaramondKrsvHlb	Times Bdl	ITC A G Go BkOb
Courier*	Helvetica	ITC A G Go Dm
Courier It	Helvetica Ob	ITC A G Go DmOb
Courier Bd	Helvetica Bd	ZapfC Mdlt
Courier Bdl	Helvetica BdOb	ZapfDingbats

## • Symbol Set

### Purpose:

To specify a symbol set for a specified font.

### Values:

ROMAN-8*	WIN L1	ISO-6
ISO L1	WIN L2	ISO-11
ISO L2	WIN L5	ISO-15
ISO L5	DESKTOP	ISO-17
ISO L6	PS TEXT	ISO-21
PC-8	MC TEXT	ISO-60
PC-8 DN	MS PUB	ISO-69
PC-775	MATH-8	WIN 3.0
PC-850	PS MATH	WINBALT
PC-852	PI FONT	SYMBOL
PC-1004	LEGAL	WINGDINGS
PC-8 TK	ISO-4	DNGBTSMS

## • Font Size

### Purpose:

To specify the font size for scalable typographic fonts, within the range of 4.00 to 50.00. The default is 12.00.

Font size refers to the height of the characters in the font. One point equals approximately 1/72 of an inch.

### NOTE:

- The Font Size menu is only displayed for typographic fonts.

## • Font Pitch

### Purpose:

To specify the font pitch for scalable mono spaced fonts, within the range of 6.00 to 24.00. The default is 10.00.

Font pitch refers to the number of fixed-space characters in a horizontal inch of type. For nonscheduled mono spaced fonts, the pitch is displayed, but cannot be changed.

### NOTE:

- The `Font Pitch` menu is only displayed for fixed or mono spaced fonts.

## • Form Line

### Purpose:

To set the number of lines in a page.

### Values:

<b>64<sup>*1</sup> (mm series)/60<sup>*1</sup> (inch series)</b>	Sets the value in increments of 1.
<b>5–128</b>	
<sup>*1</sup> Denotes country-specific factory default values.	

The printer sets the amount of space between each line (vertical line spacing) based on the `Form Line` and `Orientation` menu items. Select the correct `Form Line` and `Orientation` before changing `Form Line`.

## • Quantity

### Purpose:

To set the default print quantity, within the range of 1 to 999. The default is 1. (Set the number of copies required for a specific job from the print driver. Values selected from the print driver always override values selected from the operator panel.)

## • Image Enhance

### Purpose:

To specify whether to enable the Image Enhance feature, which makes the boundary line between black and white smoother to decrease jagged edges and enhance the visual appearance.

### Values:

<b>Off</b>	Disables the Image Enhance feature.
<b>On<sup>*</sup></b>	Enables the Image Enhance feature.

## • Hex Dump

### Purpose:

To help isolate the source of a print job problem. With `Hex Dump` selected, all data sent to the printer is printed in hexadecimal and character representation. Control codes are not executed.

### Values:

<b>Disable<sup>*</sup></b>	Disables the Hex Dump feature.
<b>Enable</b>	Enables the Hex Dump feature.

## • Draft Mode

### Purpose:

To save toner by printing in the draft mode. The print quality is reduced when you print in the draft mode.

### Values:

<b>Disable*</b>	Does not print in the draft mode.
<b>Enable</b>	Prints in the draft mode.

## • Line Termination

### Purpose:

To add the line termination commands.

### Values:

<b>Off*</b>	The line termination command is not added. CR=CR, LF=LF, FF=FF
<b>Add-LF</b>	The LF command is added. CR=CR-LF, LF=LF, FF=FF
<b>Add-CR</b>	The CR command is added. CR=CR, LF=CR-LF, FF=CR-FF
<b>CR-XX</b>	The CR and LF commands are added. CR=CR-LF, LF=CR-LF, FF=CR-FF

## • Output Color

### Purpose:

To specify the color mode to `Color` or `Black and White`. This setting is used for a print job that does not specify a print mode.

### Values:

<b>Black and White*</b>	Prints in the black and white mode.
<b>Color</b>	Prints in the color mode.

## PDF Settings

Use the `PDF Settings` menu to change printer settings that only affect the PDF jobs.

### NOTE:

- Values marked by an asterisk (\*) are the factory default menu settings.

## • Quantity

### Purpose:

To specify the number of copies to print.

### Values:

<b>1 sets*</b>	Sets the value in increments of 1.
<b>1–999</b>	

## • 2-Sided Print

### Purpose:

To specify whether to print on both sides of a sheet of paper.

### Values:

1-Sided*	Prints on one side of a sheet of paper.
Long Edge Flip	Prints on both sides of a sheet of paper to be bound by long edge.
Short Edge Flip	Prints on both sides of a sheet of paper to be bound by short edge.

## • Print Mode

### Purpose:

To specify the print mode.

### Values:

Normal*	For documents with normal sized characters.
High Quality	For documents with small characters or thin lines, or documents printed using a dot-matrix printer.
High Speed	Prints with the higher speed than the Normal mode, but the quality is less.

## • Password

### Purpose:

To specify the password to print the secure PDF.

### Value:

Password	Enter the password to print the secure PDF.
----------	---

## • Collated

### Purpose:

To specify whether to sort the job.

### Values:

Off*	Does not sort the job.
On	Sorts the job.

## • Output Size

### Purpose:

To specify the output paper size for PDF.

### Values:

A4 - 210x297* <sup>1</sup>
Letter - 8.5x11* <sup>1</sup>
Auto

\*<sup>1</sup> The default paper size is displayed.

## • Layout

### Purpose:

To specify the output layout.

### Values:

Auto %*
100% (No Zoom)
Booklet
2 Pages Up
4 Pages Up

## • Output Color

### Purpose:

To specify the output color.

### Values:

Color (Auto)*
Black and White

## PS Settings

Use the PS Settings menu to change printer settings that only affect jobs using the PostScript emulation printer language.

### NOTE:

- Values marked by an asterisk (\*) are the factory default menu settings.

## • PS Error Report

### Purpose:

To specify whether to print the contents of PostScript errors.

### Values:

Off	Dose not print the PS error report.
On*	Prints the PS error report.

## • PS Job Time-out

### Purpose:

To specify the runtime of one PostScript job.

### Values:

Off*	Does not set the runtime of a PostScript job.
On	Sets the runtime of a PostScript job.
	1 min.
	1-900 min.

## • Paper Select Mode

### Purpose:

To set the way to select the paper tray for PostScript mode.

### Values:

<b>Auto*</b>	Automatically selects the paper tray for PostScript mode.
<b>Select FromTray</b>	Manually selects the paper tray for PostScript mode.

## • Output Color

### Purpose:

To set the default color for PostScript.

### Values:

<b>Color*</b>	Prints in color mode.
<b>Black and White</b>	Prints in black and white mode.

## Wired Network

Use the **Wired Network** menu to change the printer settings affecting jobs sent to the printer through the wired network.

### NOTE:

- Values marked by an asterisk (\*) are the factory default menu settings.

## • Ethernet

### Purpose:

To specify the communication speed and the duplex settings of Ethernet. The change becomes effective after the printer is turned off and then on again.

### Values:

<b>Auto*</b>	Detects the Ethernet settings automatically.
<b>10BASE-T Half</b>	Uses 10BASE-T Half-duplex.
<b>10BASE- T Full</b>	Uses 10BASE-T Full-duplex.
<b>100BASE- TX Half</b>	Uses 100BASE-TX Half-duplex.
<b>100BASE- TX Full</b>	Uses 100BASE-TX Full-duplex.
<b>1000BASE- T Full</b>	Uses 1000BASE-T Full-duplex.

## • TCP/IP

### Purpose:

To configure TCP/IP settings.

### Values:

<b>IP Mode</b>	<b>Dual Stack*</b>	Uses both IPv4 and IPv6 to set the IP address.
	<b>IPv4</b>	Uses IPv4 to set the IP address.
	<b>IPv6</b>	Uses IPv6 to set the IP address.

<b>IPv4</b>	<b>Get IP Address</b>	<b>DHCP / Autonet*</b>	Sets the IP address automatically. A random value in the range of 169.254.1.0 to 169.254.254.255 that is not currently in use on the network is set as the IP address. The subnet mask is set as 255.255.0.0.
		<b>BOOTP</b>	Sets the IP address using BOOTP.
		<b>RARP</b>	Sets the IP address using RARP.
		<b>DHCP</b>	Sets the IP address using DHCP.
		<b>Panel</b>	Use this option when you want to set the IP address manually on the operator panel.
		<b>IP Address</b>	
	<b>Subnet Mask</b>		When an IP address is being set manually, the subnet mask is specified using the format <i>nnn.nnn.nnn.nnn</i> . Each octet that makes up <i>nnn.nnn.nnn.nnn</i> is a value in the range of 0 to 255. 255.255.255 cannot be specified as the subnet mask.
	<b>Gateway Address</b>		When an IP address is being set manually, the gateway address is specified using the format <i>nnn.nnn.nnn.nnn</i> . Each octet that makes up <i>nnn.nnn.nnn.nnn</i> is a value in the range of 0 to 254. 127 and any value in the range of 224 to 254 cannot be specified for the first octet of a gateway address.
<b>IPsec</b>	<b>Disable*</b>		Disables IPsec.

## • Protocol

### Purpose:

To enable or disable each protocol. The change becomes effective after the printer is turned off and then on again.

### Values:

<b>LPD</b>	<b>Disable</b>	Disables the Line Printer Daemon (LPD) port.
	<b>Enable*</b>	Enables the LPD port.
<b>Port9100</b>	<b>Disable</b>	Disables the Port9100 port.
	<b>Enable*</b>	Enables the Port9100 port.
<b>FTP</b>	<b>Disable</b>	Disables the FTP port.
	<b>Enable*</b>	Enables the FTP port.
<b>IPP</b>	<b>Disable</b>	Disables IPP port.
	<b>Enable*</b>	Enables IPP port.
<b>SMB (TCP/IP)</b>	<b>Disable</b>	Disables SMB TCP/IP port.
	<b>Enable*</b>	Enables SMB TCP/IP port.
<b>SMB (NetBEUI)</b>	<b>Disable</b>	Disables SMB Net BEUI port.
	<b>Enable*</b>	Enables SMB Net BEUI port.
<b>WSD</b>	<b>Disable</b>	Disables WSD port.
	<b>Enable*</b>	Enables WSD port.
<b>SNMP (UDP/IP)</b>	<b>Disable</b>	Disables the Simple Network Management Protocol (SNMP) UDP port.
	<b>Enable*</b>	Enables the SNMP UDP port.



<b>StatusMessenger</b>	<b>Disable</b>	Disables the E-Mail Alert feature.
	<b>Enable*</b>	Enables the E-Mail Alert feature.
<b>InternetServices</b>	<b>Disable</b>	Disables an access to <b>CentreWare Internet Services</b> embedded in the printer.
	<b>Enable*</b>	Enables an access to <b>CentreWare Internet Services</b> embedded in the printer.
<b>Bonjour(mDNS)</b>	<b>Disable</b>	Disables Bonjour (mDNS).
	<b>Enable*</b>	Enables Bonjour (mDNS).
<b>Telnet</b>	<b>Disable*</b>	Disables Telnet.
	<b>Enable</b>	Enables Telnet.
<b>HTTP-SSL/TLS</b>	<b>Disable</b>	Disables HTTP-SSL/TLS.
	<b>Enable*</b>	Enables HTTP-SSL/TLS.

## • IP Filter

### NOTE:

- IP Filter feature is available only when `Protocol` is set to `LPD` or `Port9100`.

### Purpose:

To block data received from certain IP addresses through the wired network. You can set up to five IP addresses. The change becomes effective after the printer is turned off and then on again.

### Values:

<b>No. n / Address (n is 1–5.)</b>		Sets the IP address for Filter <i>n</i> .
<b>No. n / Mask (n is 1–5.)</b>		Sets the address mask for Filter <i>n</i> .
<b>No. n / Mode (n is 1–5.)</b>	<b>Off*</b>	Disables the IP Filter feature for Filter <i>n</i> .
	<b>Accept</b>	Accepts an access from the specified IP address.
	<b>Reject</b>	Rejects an access from the specified IP address.

## • IEEE 802.1x

### NOTE:

- IEEE 802.1x feature is available only when the printer is connected using LAN cable and it is available only when the IEEE 802.1 authentication is enabled.

### Purpose:

To disable IEEE 802.1x authentication. The change becomes effective after the printer is turned off and then on again.

### Value:

<b>Disable</b>	Disables IEEE 802.1x.
----------------	-----------------------

## • Initialize NVM

### Purpose:

To initialize wired network data stored in non-volatile memory (NVM). After executing this function and rebooting the printer, all wired network settings are reset to their default values.

## • Adobe Protocol

### Purpose:

To set the PostScript communications protocol.

### Values:

<b>Auto*</b>	Sets the PostScript communications protocol automatically.
<b>Standard</b>	Sets the PostScript communications protocol to <i>Standard</i> .
<b>BCP</b>	Sets the PostScript communications protocol to <i>BCP</i> .
<b>TBCP</b>	Sets the PostScript communications protocol to <i>TBCP</i> .
<b>Binary</b>	Sets the PostScript communications protocol to <i>Binary</i> .

•

## USB Settings

Use the *USB Settings* menu to change printer settings affecting a USB port.

### NOTE:

- Values marked by an asterisk (\*) are the factory default menu settings.

## • Port Status

### Purpose:

To specify whether to enable the USB port. The change becomes effective after the printer is turned off and then on again.

### Values:

<b>Disable</b>	Disables the USB interface.
<b>Enable*</b>	Enables the USB interface.

## • Adobe Protocol

### Purpose:

To set the PostScript communications protocol.

### Values:

<b>Auto</b>	Sets the PostScript communications protocol automatically.
<b>Standard</b>	Sets the PostScript communications protocol to <i>Standard</i> .
<b>BCP</b>	Sets the PostScript communications protocol to <i>BCP</i> .
<b>TBCP*</b>	Sets the PostScript communications protocol to <i>TBCP</i> .
<b>Binary</b>	Sets the PostScript communications protocol to <i>Binary</i> .

## System Settings

Use *System Settings* to configure a variety of printer features.

### NOTE:

- Values marked by an asterisk (\*) are the factory default menu settings.

## • Power Saver Time

### Purpose:

To specify the time for transition to power saver mode.

### Values:

<b>Low Power Timer</b>	<b>3min*</b> <b>3–60 min.</b>	Specifies the time taken by the printer to enter Low Power mode after it finishes a job.
<b>Sleep Timer</b>	<b>6min*</b> <b>1–6 min.</b>	Specifies the time taken by the printer to enter Sleep mode after it has entered Low Power mode.

Enter 5 to put the printer in power saver mode five minutes after it finishes a job. This uses much less energy, but requires more warm-up time for the printer. Enter 5 if your printer shares an electrical circuit with room lighting and you notice lights flickering.

Select a high value if your printer is in constant use. In most circumstances, this keeps the printer ready to operate with minimum warm-up time. Select a value between 5 and 30 minutes for power saver mode if you want a balance between energy consumption and a shorter warm-up period.

The printer automatically returns to the standby mode from the power saver mode when it receives data from the computer. You can also change the status of the printer to the standby mode by pressing the **Energy Saver** button on the operator panel.

## • Auto Reset

### Purpose:

To automatically reset the settings to the default settings and return to the standby mode after you do not specify any settings for the specified time.

### Values:

<b>45sec*</b>
<b>1min</b>
<b>2min</b>
<b>3min</b>
<b>4min</b>

## • Fault Time-out

### Purpose:

To specify the amount of time the printer waits before canceling a job that stops abnormally. The print job is cancelled if the time-out time is exceeded.

### Values:

<b>Off</b>		Disables the fault time-out.
<b>On*</b>	<b>60sec*</b> <b>3–300 sec.</b>	Sets the amount of time the printer waits before canceling a job that stops abnormally.

## • Job Time-out

### Purpose:

To specify the amount of time the printer waits for data to arrive from the computer. The print job is cancelled if the time-out time is exceeded.

### Values:

<b>Off</b>		Disables the job time-out.
<b>On*</b>	<b>30sec*</b> <b>5–300 sec.</b>	Sets the time the printer waits for data to arrive from the computer.

## • Clock Settings

### Purpose:

To specify the date and time formats.

### Values:

<b>Set Date &amp; Time</b>	<b>Time Zone</b>	Sets the time zone.
	<b>Set Date</b>	Sets the date depending on the <code>Date Format</code> settings.
	<b>Set Time</b>	Sets the time.
<b>Date Format</b>	<b>yy/mm/dd</b>	Sets the date format.
	<b>mm/dd/yy</b>	
	<b>dd/mm/yy*</b>	
<b>Time Format</b>	<b>12H</b>	Sets the time in 12-hour format.
	<b>24H*</b>	Sets the time in 24-hour format.

\*1 The default for `Date Format` varies depending on country-specific factory default.

## • Audio Tones

### Purpose:

To configure settings for tones emitted by the printer during operation or when a warning message appears.

### Values:

<b>Control Panel</b>	<b>Off*</b>	Does not emit a tone when the operator panel input is correct.
	<b>On</b>	Emits a tone when the operator panel input is correct.
<b>Invalid Key</b>	<b>Off*</b>	Does not emit a tone when the operator panel input is incorrect.
	<b>On</b>	Emits a tone when the operator panel input is incorrect.
<b>Machine Ready</b>	<b>Off</b>	Does not emit a tone when the printer is ready to process a job.
	<b>On*</b>	Emits a tone when the printer is ready to process a job.
<b>Job Completed</b>	<b>Off</b>	Does not emit a tone when a job is complete.
	<b>On*</b>	Emits a tone when a job is complete.
<b>Fault Tone</b>	<b>Off</b>	Does not emit a tone when a job ends abnormally.
	<b>On*</b>	Emits a tone when a job ends abnormally.
<b>Alert Tone</b>	<b>Off</b>	Does not emit a tone when a problem occurs.
	<b>On*</b>	Emits a tone when a problem occurs.

<b>Out of Paper</b>	<b>Off</b>	Does not emit a tone when the printer runs out of paper.
	<b>On*</b>	Emits a tone when the printer runs out of paper.
<b>Low Toner Alert</b>	<b>Off</b>	Does not emit a tone when a toner is low.
	<b>On*</b>	Emits a tone when a toner is low.
<b>AutoClear Alert</b>	<b>Off*</b>	Does not emit a tone 5 seconds before the printer performs auto clear.
	<b>On</b>	Emits a tone 5 seconds before the printer performs auto clear.
<b>All Tones</b>	<b>Off</b>	Disables all the alert tones.
	<b>On*</b>	Sets the volume of all the alert tones at once.

## • mm / inch

### Purpose:

To specify the default measurement unit displayed after the numeric value on the operator panel.

### Values:

<b>Millimeters (mm)*</b>	Selects millimeter as the default measurement unit.
<b>Inches (")</b>	Selects inch as the default measurement unit.

### NOTE:

- The default for mm/inch varies depending on other settings, such as Country and Document Size.

## • DefaultPaperSize

### Purpose:

To specify the default paper size.

### Values:

<b>A4 - 210x297</b>
<b>Letter - 8.5x11</b>

### NOTE:

- The default for DefaultPaperSize varies depending on country-specific factory default.

## • Auto Job History

### Purpose:

To automatically print a job history report after every 20 jobs.

### Values:

<b>Off*</b>	Does not automatically print a job history report.
<b>On</b>	Automatically prints a job history report.

The Job History report can also be printed using the Report/List menu.

## • Print ID

### Purpose:

To specify a location where the user ID is printed.

### Values:

<b>Off*</b>	Does not print the user ID.
<b>Top Left</b>	Prints the user ID on the top left of the page.
<b>Top Right</b>	Prints the user ID on the top right of the page.
<b>Bottom Left</b>	Prints the user ID on the bottom left of the page.
<b>Bottom Right</b>	Prints the user ID on the bottom right of the page.

### NOTE:

- When you print on DL size paper, a part of the user ID may not be printed correctly.

## • Print Text

### Purpose:

To specify whether the printer outputs PDL data, which is not supported by the printer, as text when the printer receives it. Text data is printed on A4 or Letter size paper.

### Values:

<b>Off</b>	Does not print the received data.
<b>On*</b>	Prints the received data as text data.

## • Banner Sheet

### NOTE:

- Banner Sheet feature is available only when the optional 250-sheet feeder is installed on the printer.

### Purpose:

To specify the position of banner sheet, and also specify the tray in which the banner sheet is loaded.

### Values:

<b>Insert Position</b>	<b>Off*</b>	Does not print the banner sheet.
	<b>Start Sheet</b>	Inserted before the first page of every job.
	<b>End Sheet</b>	Inserted after the last page of every job.
	<b>Start&amp;End Sheet</b>	Inserted before the first page of every job and after the last page of every job.
<b>Select Tray</b>	<b>Tray 1*</b>	The banner sheet is loaded in the standard 250-sheet tray.
	<b>Tray 2</b>	The banner sheet is loaded in the optional 250-sheet feeder.

## • RAM Disk

### NOTE:

- RAM Disk feature is available only when the 512 MB optional memory module is installed on the printer.

### Purpose:

To allocate memory to the RAM disk file system for the Secure Print and Sample Print features. The change becomes effective after the printer is turned off and then on again.

### Values:

<b>Disable</b>		Does not allocate memory to the RAM disk file system. Secure Print and Sample Print jobs will abort and be recorded to the job log.
<b>Enable*</b>	<b>300MB*</b> <b>50-500MB</b>	Sets the allocation of memory to the RAM disk file system in increments of 50 MB.

### NOTE:

- Restart your printer when you change the settings for the RAM Disk menu.

## • Substitute Tray

### Purpose:

Specifies whether to use paper of a different size when the paper that is loaded in the specified tray does not match the paper size settings for the current job.

### Values:

<b>Off*</b>	No tray size substitute accepted.
<b>Larger Size</b>	Substitutes paper of next largest size. When there is no larger paper size, the printer substitutes paper of nearest size.
<b>Closest Size</b>	Substitutes paper of nearest size.

## • Auditron Mode

### Purpose:

To specify whether to limit the functions that can be used per user by Auditron authentication.

### Values:

<b>Off*</b>	Does not limit functions by Auditron authentication.
<b>On</b>	Limits functions by Auditron authentication.

## • No Acct User Prt

### Purpose:

To specify whether to permit the printing of data without authentication information.

### Values:

<b>Off*</b>	Does not permit non-account user to print the data.
<b>On</b>	Permits non-account user to print the data.

## • LetterH Dup Mode

### Purpose:

To specify whether to print on both sides when you use letterhead.

### Values:

<b>Disable*</b>	Does not print on both sides of letterhead.
<b>Enable</b>	Prints on both sides of letterhead.

## • Low Toner Msg

### Purpose:

To specify whether to show the alert message when the toner is low.

### Values:

<b>Off</b>	Does not show the alert message when the toner is low.
<b>On*</b>	Shows the alert message when the toner is low.

## Maintenance Mode

Use the `Maintenance Mode` menu to initialize the NV (non-volatile) memory, configure the plain paper quality adjustment settings, and configure the security settings.

### NOTE:

- Values marked by an asterisk (\*) are the factory default menu settings.

## • F/W Version

### Purpose:

To confirm the current F/W version.

## • Adjust PaperType

### Purpose:

To specify paper density settings.

### Values:

<b>Plain</b>	<b>Lightweight</b>
	<b>Heavyweight*</b>
<b>Labels</b>	<b>Lightweight</b>
	<b>Heavyweight*</b>



## • Adjust BTR

### Purpose:

To specify the transfer roller voltage adjustment for each paper type.

The default settings may not give the best output on all paper types. If you see mottles on the print output, try to increase the voltage. If you see white spots on the print output, try to decrease the voltage.

### NOTE:

- The print quality changes depending on the setting values you select for this item.

### Values:

Plain	0*
	-6 to +6
Light Card	0*
	-6 to +6
Heavy Card	0*
	-6 to +6
Envelope	0*
	-6 to +6
Labels	0*
	-6 to +6
LW Gloss Card	0*
	-6 to +6
HW Gloss Card	0*
	-6 to +6

## • Adjust Fuser

### Purpose:

To adjust the fusing temperature setting for each paper type.

The default settings may not give the best output on all paper types. When the printed paper has curled, try to lower the temperature. When the toner does not fuse on the paper properly, try to increase the temperature.

### NOTE:

- The print quality changes depending on the setting values you select for this item.

### Values:

Plain	0*
	-6 to +6
Light Card	0*
	-6 to +6
Heavy Card	0*
	-6 to +6
Envelope	0*
	-6 to +6

Labels	0*
	-6 to +6
LW Gloss Card	0*
	-6 to +6
HW Gloss Card	0*
	-6 to +6

## • Auto Adjust Regi

### Purpose:

To specify whether to automatically perform color registration adjustment.

### Values:

Off	Does not automatically perform color registration adjustment.
On*	Automatically performs color registration adjustment.

## • Adjust ColorRegi

### Purpose:



To manually perform color registration adjustment.

Manual Color Registration Adjustments are required when the printer is initially installed and after the printer is moved.

### NOTE:

- The `Adjust ColorRegi` feature can be configured when `Auto Adjust Regi` is set to `Off`.

### Values:

<b>Auto Adjust</b>	Automatically performs color registration correction.																			
<b>ColorRegi Chart</b>	Prints a color registration chart. The color registration chart prints a lattice pattern of yellow, magenta, and cyan lines. On the chart, find the values on the right side that are next to the line that is perfectly straight for each of the three colors. If the value for this line is 0, color registration adjustment is not required. If the value for this line is any value other than 0, specify the adjustment values for lateral adjustment and process adjustment under <b>Enter Number</b> .																			
<b>Enter Number</b>	<table border="0"> <tr> <td><b>LY</b></td> <td><b>-9 to +9</b></td> <td rowspan="10">Sets lateral (perpendicular to paper feed direction) and process (paper feed direction) color adjustment values individually for Yellow, Magenta, and Cyan. Enter a number in order of lateral adjustment (left), lateral adjustment (right), and process adjustment. Press the  button to save all the settings.</td> </tr> <tr> <td><b>LM</b></td> <td></td> </tr> <tr> <td><b>LC</b></td> <td></td> </tr> <tr> <td><b>RY</b></td> <td><b>-9 to +9</b></td> </tr> <tr> <td><b>RM</b></td> <td></td> </tr> <tr> <td><b>RC</b></td> <td></td> </tr> <tr> <td><b>PY</b></td> <td><b>-9 to +9</b></td> </tr> <tr> <td><b>PM</b></td> <td></td> </tr> <tr> <td><b>PC</b></td> <td></td> </tr> </table>	<b>LY</b>	<b>-9 to +9</b>	Sets lateral (perpendicular to paper feed direction) and process (paper feed direction) color adjustment values individually for Yellow, Magenta, and Cyan. Enter a number in order of lateral adjustment (left), lateral adjustment (right), and process adjustment. Press the  button to save all the settings.	<b>LM</b>		<b>LC</b>		<b>RY</b>	<b>-9 to +9</b>	<b>RM</b>		<b>RC</b>		<b>PY</b>	<b>-9 to +9</b>	<b>PM</b>		<b>PC</b>	
<b>LY</b>	<b>-9 to +9</b>	Sets lateral (perpendicular to paper feed direction) and process (paper feed direction) color adjustment values individually for Yellow, Magenta, and Cyan. Enter a number in order of lateral adjustment (left), lateral adjustment (right), and process adjustment. Press the  button to save all the settings.																		
<b>LM</b>																				
<b>LC</b>																				
<b>RY</b>	<b>-9 to +9</b>																			
<b>RM</b>																				
<b>RC</b>																				
<b>PY</b>	<b>-9 to +9</b>																			
<b>PM</b>																				
<b>PC</b>																				

### NOTE:

- Ensure that you remove the paper from the single sheet feeder (SSF) before performing `Auto Adjust`.

## • Clean Developer

### Purpose:

To stir the toner in a new toner cartridge.

## • Toner Refresh

### Purpose:

To clean the toner in each toner cartridge.

### Values:

<b>Yellow Crtrdg</b>	Cleans the toner in the yellow toner cartridge.
<b>Magenta Crtrdg</b>	Cleans the toner in the magenta toner cartridge.
<b>Cyan Crtrdg</b>	Cleans the toner in the cyan toner cartridge.
<b>Black Crtrdg</b>	Cleans the toner in the black toner cartridge.

## • Drum Refresh

### Purpose:

To clean the surface of the drum cartridge.

## • Initialize NVM

### Purpose:

To initialize the non-volatile (NV) memory. After executing this function and rebooting the printer, all the menu parameters are reset to their default values.

### See also:

- ["Resetting to Factory Defaults" on page 177.](#)

## • Init Print Meter

### Purpose:

To initialize the print meter of the printer. When the print meter is initialized, the meter count is reset to zero.

## • Reset Fuser

### Purpose:

To initialize the Machine Control Unit life counter.

## • Clear Storage

### NOTE:

- Clear Storage feature is available only when the 512 MB optional memory module is installed.

### Purpose:

To clear all files stored as Secure Print, Sample Print, and Stored Print in the RAM disk.

### Values:

<b>All Clear</b>	Deletes all files stored as Secure Print and Sample Print in the RAM disk.
<b>Secure Document</b>	Deletes all files stored as Secure Print in the RAM disk.
<b>Stored Document</b>	Deletes all files stored as Stored Print in the RAM disk.

## • Non-Genuine

### Purpose:

To use toner cartridge of another manufacturer.

### NOTE:

- Using a non-Fuji Xerox toner cartridge may severely damage your printer. The warranty does not cover damages caused by using non-Fuji Xerox toner cartridges.

### Values:

<b>Toner</b>	<b>Off*</b>	Does not use toner cartridge of another manufacturer.
	<b>On</b>	Uses toner cartridge of another manufacturer.

## • Adjust Altitude

### Purpose:

To specify the altitude of the location where the printer is installed.

The discharge phenomenon for charging the photo conductor varies with barometric pressure. Adjustments are performed by specifying the altitude of the location where the printer is being used.

### NOTE:

- An incorrect altitude adjustment setting leads to problems such as poor printing quality and incorrect indication of remaining toner.

### Values:

<b>0m*</b>	Sets the altitude of the location where the printer is installed.
<b>1000m</b>	
<b>2000m</b>	
<b>3000m</b>	

## Secure Settings

Use the `Secure Settings` menu to set a password to limit access to the menus. This prevents items from being changed accidentally.

### NOTE:

- Values marked by an asterisk (\*) are the factory default menu settings.

## • Panel Lock

### Purpose:

To set a limited access to Admin Menu with a password, and to set or change the password.

### See also:

- ["Panel Lock Function" on page 173.](#)

### Values:

<b>Panel Lock Set</b>	<b>Disable*</b>	Disables password protection for Admin Menu.
	<b>Enable</b>	Enables password protection for Admin Menu.
<b>Change Password*<sup>1</sup></b>	<b>0000–9999</b>	Sets or changes the password required to access Admin Menu.

<sup>1</sup> This item is available only when Panel Lock Set is set to Enable.

## • Login Error

### NOTE:

- Login Error feature is available only when Panel Lock Set is set to Enable.

### Purpose:

To specify the number of error entry attempts allowed when you log in as an administrator in the Admin Menu and Report/List menu.

### Values:

<b>Off*</b>		Does not allow an administrator to log in after one error entry attempt.
<b>On</b>	<b>5 times*</b> <b>1-10</b>	Sets the number of error entry attempts allowed when an administrator logs in.

## ■ Tray Settings

Use the `Tray Settings` menu to define the print media loaded in the standard 250-sheet tray and the optional 250-sheet feeder.

### NOTE:

- Values marked by an asterisk (\*) are the factory default menu settings.

# Tray 1

## Purpose:

To specify the paper loaded in the standard 250-sheet tray.

## Values:

Paper Size	<b>A4 - 210x297*</b>				
	mm series	<b>A5 - 148x210</b>			
		<b>B5 - 182x257</b>			
		<b>Letter - 8.5x11</b>			
		<b>US Folio-8.5x13</b>			
		<b>Legal - 8.5x14</b>			
		<b>Executive</b>			
		<b>Monarch Env.</b>			
		<b>Monarch Env. L</b>			
		<b>DL Env- 110x220</b>			
		<b>DL Env. L</b>			
		<b>C5 Env- 162x229</b>			
		<b>#10Env- 4.1x9.5</b>			
		New Custom Size	Portrait (Y)	297 mm*	Specifies the length of the custom size paper.
				127 - 355 mm	
Landscape (X)			210 mm*	Specifies the width of the custom size paper.	
	77 - 215 mm				
inch series	<b>Letter - 8.5x11*</b>				
	<b>US Folio-8.5x13</b>				
	<b>Legal - 8.5x14</b>				
	<b>A4 - 210x297</b>				
	<b>A5 - 148x210</b>				
	<b>B5 - 182x257</b>				
	<b>Executive</b>				
	<b>Monarch Env.</b>				
	<b>Monarch Env. L</b>				
	<b>DL Env- 110x220</b>				
	<b>DL Env. L</b>				
	<b>C5 Env- 162x229</b>				
	<b>#10Env- 4.1x9.5</b>				
	New Custom Size	Portrait (Y)	11.7 inch*	Specifies the length of the custom size paper.	
			5.0-14.0 inches		
Landscape (X)	8.3 inch*	3.0-8.5 inches	Specifies the width of the custom size paper.		

<b>Paper Type</b>	<b>Plain*</b>	
	<b>Light Card</b>	
	<b>Heavy Card</b>	
	<b>Envelope</b>	
	<b>Labels</b>	
	<b>Letterhead</b>	
	<b>LW Gloss Card</b>	
	<b>HW Gloss Card</b>	
	<b>Hole Punched</b>	
	<b>Colored</b>	
	<b>Special</b>	
<b>Display Screen</b>	<b>Off</b>	Does not display a popup menu that prompts to set <b>Paper Type</b> and <b>Paper Size</b> when paper is loaded in the standard 250-sheet tray.
	<b>On*</b>	Displays a popup menu that prompts to set <b>Paper Type</b> and <b>Paper Size</b> when paper is loaded in the standard 250-sheet tray.

\*1 The default for **Paper Size** varies depending on country-specific factory default.

**NOTE:**

- For more information on supported paper sizes, see also "[Usable Print Media](#)" on page 100.



## Tray 2

### NOTE:

- Tray 2 feature is available only when the optional 250-sheet feeder is installed.

### Purpose:

To specify the paper loaded in the optional 250-sheet feeder.

### Values:

<b>Paper Size</b>	<b>A4 - 210x297<sup>*1</sup></b>	
	mm series	<b>A5 - 148x210</b>
		<b>B5 - 182x257</b>
		<b>Letter - 8.5x11</b>
		<b>US Folio - 8.5x13</b>
		<b>Legal - 8.5x14</b>
		<b>Executive</b>
	inch series	<b>Letter - 8.5x11<sup>*1</sup></b>
		<b>US Folio - 8.5x13</b>
		<b>Legal - 8.5x14</b>
		<b>A4 - 210x297</b>
		<b>A5 - 148x210</b>
		<b>B5 - 182x257</b>
		<b>Executive</b>
<b>Colored</b>		
<b>Paper Type</b>	<b>Plain*</b>	
	<b>Letterhead</b>	
	<b>Hole Punched</b>	
	<b>Colored</b>	
<b>Display Screen</b>	<b>Off</b>	Does not display a popup menu that prompts to set <b>Paper Type</b> and <b>Paper Size</b> when paper is loaded in the optional 250-sheet feeder.
	<b>On*</b>	Displays a popup menu that prompts to set <b>Paper Type</b> and <b>Paper Size</b> when paper is loaded in the optional 250-sheet feeder.
<sup>*1</sup> The default for <b>Paper Size</b> varies depending on country-specific factory default.		

### NOTE:

- For more information on supported paper sizes, see also "[Usable Print Media](#)" on page 100.

# Panel Lock Function







---

This feature prevents unauthorized users from changing settings made by the administrator. However, you can select settings for individual print jobs using the print driver.





This section includes:

- ["Enabling the Panel Lock" on page 174](#)
- ["Disabling the Panel Lock" on page 175](#)







## ■ Enabling the Panel Lock

- 1 Press the **Menu** button.
- 2 Select `Admin Menu`, and then press the  button.
- 3 Select `Secure Settings`, and then press the  button.
- 4 Select `Panel Lock`, and then press the  button.
- 5 Select `Panel Lock Set`, and then press the  button.
- 6 Select `Enable`, and then press the  button.
- 7 Enter the new password, and then press the  button.
- 8 Re-enter the password to confirm the password that you entered, and then press the  button.

### NOTE:

- The factory-default panel password is 0000.
- If you forget your password, turn off the printer. Then, while holding the **Menu** button, turn on the printer. Continue to hold the **Menu** button until the display indicates to enter the new password. Enter the new password, and then press the  button. Re-enter the password, and then press the  button. The display will briefly indicate the password has been initialized.
- If you change the password, perform steps 1 to 2. Enter the current password, and then press the  button. Perform steps 3 to 4. Select `Change Password`, and then press the  button. Enter the current password, and then press the  button. Perform steps 7 and 8. This will change the password.









## ■ Disabling the Panel Lock

- 1 Press the **Menu** button.
- 2 Select `Admin Menu`, and then press the  button.
- 3 Enter the password, and then press the  button.
- 4 Select `Secure Settings`, and then press the  button.
- 5 Select `Panel Lock`, and then press the  button.
- 6 Select `Panel Lock Set`, and then press the  button.
- 7 Select `Disable`, and then press the  button.
- 8 Enter the current password, and then press the  button.

# Setting the Power Saver Time Option

---





You can set the power saver time for the printer. The printer switches to the Power Saver mode after the specified time.

- 1 Press the **Menu** button.
- 2 Select `Admin Menu`, and then press the  button.
- 3 Select `System Settings`, and then press the  button.
- 4 Select `Power Saver Time`, and then press the  button.
- 5 Select `Low Power Timer` or `Sleep Timer`, and then press the  button.
- 6 Press the  or  button or enter the desired value, and then press the  button.  
You can select from 3–60 minutes for `Low Power Timer` or 1–6 minutes for `Sleep Timer`.
- 7 To return to the previous screen, press the  (**Back**) button.

# Resetting to Factory Defaults

---

After executing Initialize NVM and rebooting the printer, all the menu parameters or data are reset to their default values.

- 1 Press the **Menu** button.
- 2 Select `Admin Menu`, and then press the  button.
- 3 Select `Maintenance Mode`, and then press the  button.
- 4 Select `Initialize NVM`, and then press the  button.
- 5 Ensure that `Are You Sure?` appears, and then press the  button.  
The printer restarts automatically to apply the settings.



# Troubleshooting

This chapter includes:

- ["Clearing Jams" on page 180](#)
- ["Basic Printer Problems" on page 199](#)
- ["Display Problems" on page 200](#)
- ["Printing Problems" on page 201](#)
- ["Print Quality Problems" on page 203](#)
- ["Adjusting Color Registration" on page 227](#)
- ["Other Problems" on page 234](#)
- ["Understanding Printer Messages" on page 235](#)
- ["Contacting Service" on page 238](#)
- ["Getting Help" on page 239](#)
- ["Non-Genuine Mode" on page 243](#)



# Clearing Jams

---

This section includes:

- ["Avoiding Jams" on page 181](#)
- ["Identifying the Location of Paper Jams" on page 182](#)
- ["Clearing Paper Jams From the SSF" on page 183](#)
- ["Clearing Paper Jams From the Standard 250-Sheet Tray" on page 186](#)
- ["Clearing Paper Jams From the Fuser Unit" on page 189](#)
- ["Clearing Paper Jams From the Duplexer" on page 191](#)
- ["Clearing Paper Jams From the Optional 250-Sheet Feeder" on page 192](#)

Careful selection of appropriate print media and proper loading allow you to avoid most jams.

## See also:

- ["About Print Media" on page 94](#)
- ["Supported Print Media" on page 98](#)

## NOTE:

- Before buying large quantities of any print media, it is recommended that you try a sample first.

## ■ Avoiding Jams

- Use only recommended print media.
- See ["Loading Print Media in the Standard 250-Sheet Tray and the Optional 250-Sheet Feeder" on page 105](#) and ["Loading Print Media in the Single Sheet Feeder \(SSF\)" on page 110](#) to load print media properly.
- Do not overload the print media sources. Ensure that the print media stack height does not exceed the maximum height indicated by the load-line labels in the tray.
- Do not load wrinkled, creased, damp, or curled print media.
- Flex, fan, and straighten print media before you load it. If a jam occurs with print media, try feeding one sheet at a time through the single sheet feeder (SSF).
- Do not use print media that you have cut or trimmed.
- Do not mix print media sizes, weights, or types in the same print media source.
- Ensure that the recommended print side is face up when you load the print media in the standard 250-sheet tray and the optional 250-sheet feeder. Also, the recommended print side should be face down when you use the SSF.
- Keep print media stored in an acceptable environment.
- Do not remove the feeding tray during a print job.
- Push the tray in firmly after loading.
- Ensure that all cables that connect to the printer are correctly attached.
- Overtightening the guides may cause jams.
- Wipe the feed roller in the tray or SSF with a cloth that is slightly dampened with water if jams caused by misfeeding paper occur frequently.

### See also:

- ["About Print Media" on page 94](#)
- ["Supported Print Media" on page 98](#)
- ["Print Media Storage Guidelines" on page 97](#)

## ■ Identifying the Location of Paper Jams

### CAUTION:

- Do not attempt to remove a paper jammed deeply inside the product, particularly a paper wrapped around a Fuser Unit or a heat roller. Otherwise, it may cause injuries or burns. Switch off the product promptly and contact your local Fuji Xerox representative.

### IMPORTANT:

- Do not attempt to clear any jams using tools or instruments. This may permanently damage the printer.
- The following illustration shows where paper jams may occur along the print media path.

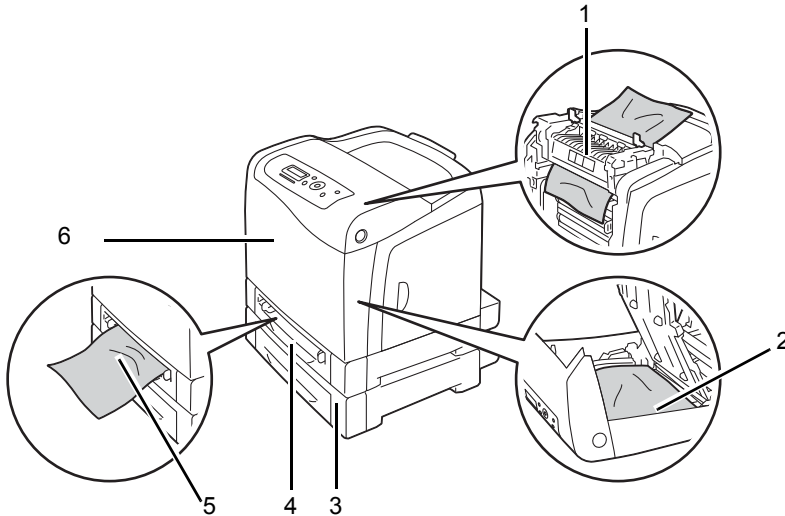

- |   |                           |
|---|---------------------------|
| 1 | Fuser Unit                |
| 2 | Duplexer                  |
| 3 | Optional 250-Sheet Feeder |
| 4 | Standard 250-Sheet Tray   |
| 5 | Single Sheet Feeder (SSF) |
| 6 | Front Cover               |

## ■ Clearing Paper Jams From the SSF

### IMPORTANT:

- Protect the drums of the drum cartridge against bright light. If the front cover remains open for more than 3 minutes, print quality may deteriorate.

### NOTE:

- To resolve the error displayed on the LCD panel, you must clear all print media from the print media path.
- 1 Pull the jammed paper out of the SSF. If you cannot remove the jammed paper or cannot find any jammed paper there, go to the next step to remove the jammed paper from the inside of the printer.

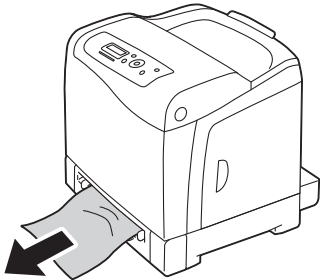

- 2 Remove the standard 250-sheet tray from the printer, and then pull out the jammed paper remaining inside the printer. If you cannot remove the jammed paper or cannot find any jammed paper there, go to the next step to remove the jammed paper from the inside of the printer.

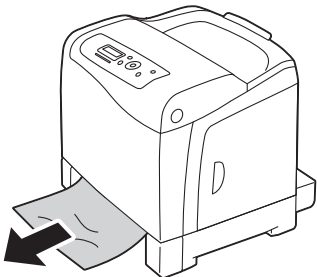
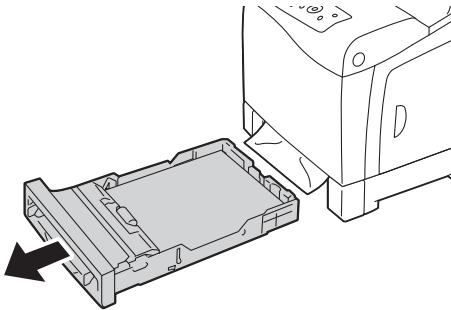

- 3 Push the side button to open the front cover.

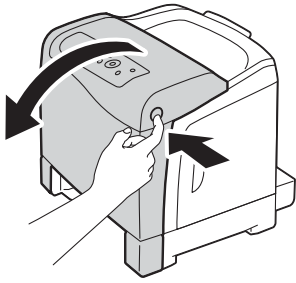

- 4** Open the belt unit until it stops and remove the jammed paper. Confirm that there are no scraps of paper remaining inside the printer.

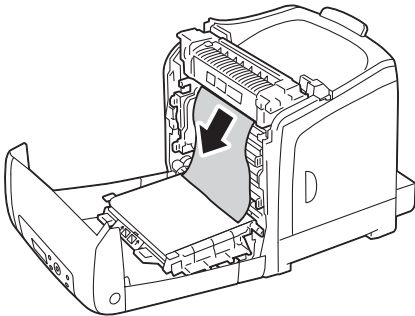
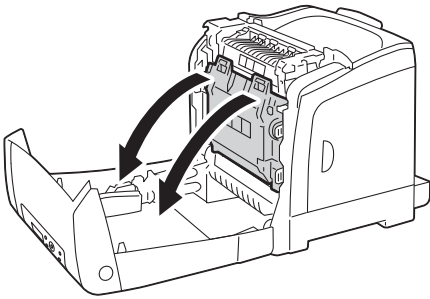

- 5** Close the belt unit, and push at the top of the unit until it clicks.

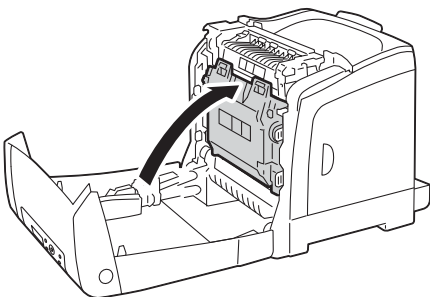

- 6** Close the front cover.

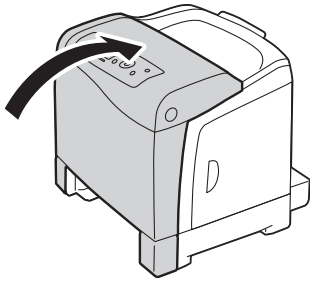

**7** Insert the standard 250-sheet tray into the printer, and push until it stops.

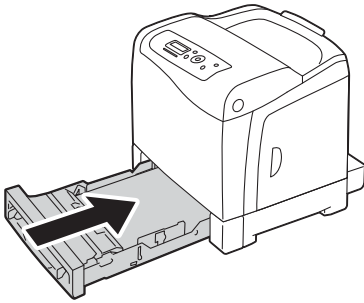

**IMPORTANT:**

- Do not use excessive force on the tray. Doing so could damage the tray or the inside of the printer.

## ■ Clearing Paper Jams From the Standard 250-Sheet Tray

### IMPORTANT:

- Protect the drums of the drum cartridge against bright light. If the front cover remains open for more than 3 minutes, print quality may deteriorate.

### NOTE:

- To resolve the error displayed on the LCD panel, you must clear all print media from the print media path.
- 1 Pull the standard 250-sheet tray out of the printer carefully. Hold the tray with both hands, lift the front slightly, and remove it from the printer.

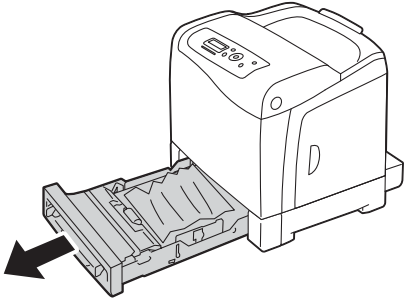

- 2 Remove all the jammed and/or creased paper from the tray.

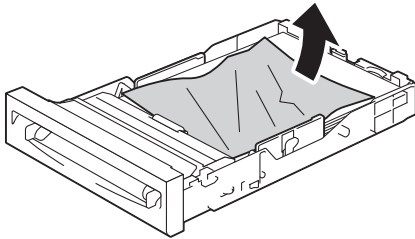

- 3 Pull the jammed paper out carefully to avoid tearing it. If you cannot remove the paper, go to the next step to remove the jammed paper from the inside of the printer.

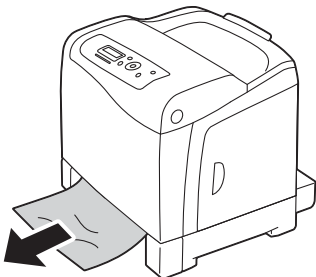

- 4 Push the side button to open the front cover.



- 5** Open the belt unit until it stops and remove the jammed paper. Confirm that there are no scraps of paper remaining inside the printer.

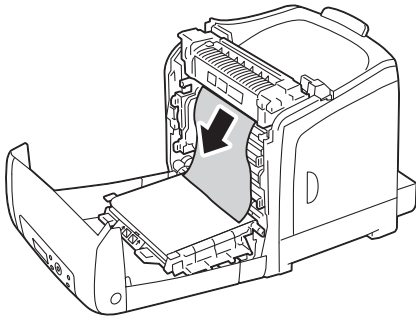
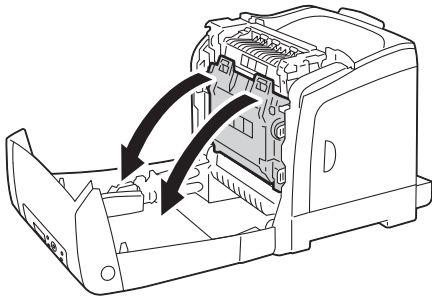

- 6** Close the belt unit, and push at the top of the unit until it clicks.

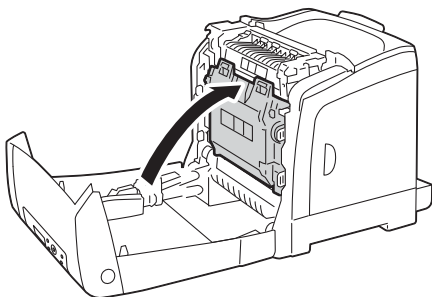

- 7** Close the front cover.



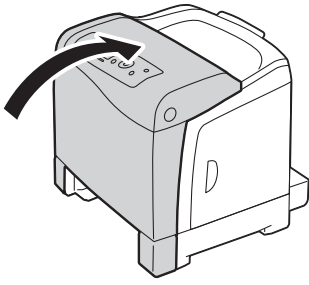

- 8 Insert the standard 250-sheet tray into the printer, and push until it stops.

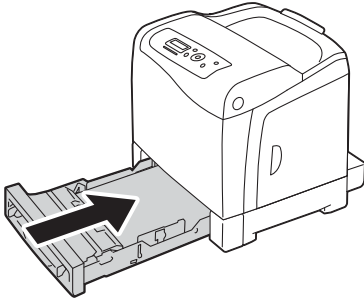

**IMPORTANT:**

- Do not use excessive force on the tray. Doing so could damage the tray or the inside of the printer.

## ■ Clearing Paper Jams From the Fuser Unit

### IMPORTANT:

- Ensure nothing touches or scratches the surface (black-colored film) of the belt unit. Scratches, dirt, or oil from your hands on the film of the belt unit may reduce print quality.
- Protect the drums of the drum cartridge against bright light. If the front cover remains open for more than 3 minutes, print quality may deteriorate.

### NOTE:

- To resolve the error displayed on the LCD panel, you must clear all print media from the print media path.

- 1 Turn off the printer and wait for 30 minutes.
- 2 Push the side button to open the front cover.

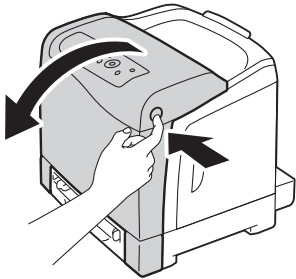

- 3 Open the belt unit.

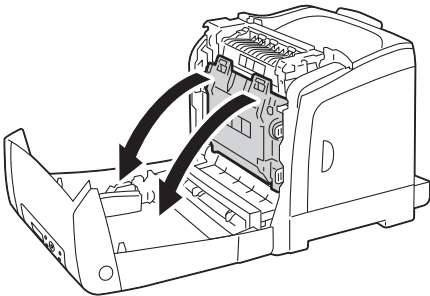

- 4 Lift the levers at both ends of the fuser unit, and remove the jammed paper. If you are still unable to remove the paper, go to the next step.

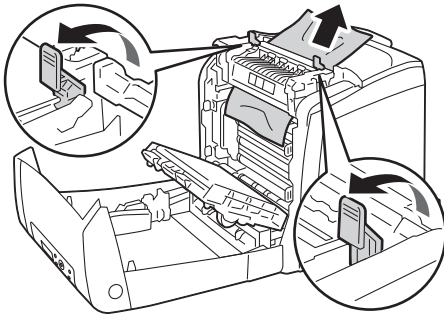

### CAUTION:

- The fuser unit is hot. Do not touch it, doing so may cause burns.

- 5** Open the cover of the fuser unit and remove the jammed paper.

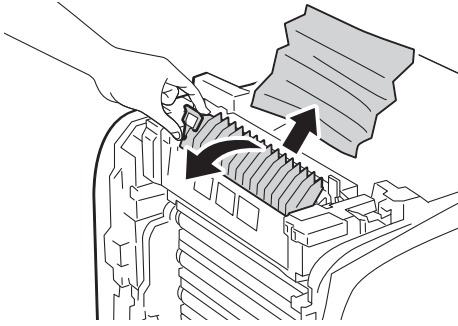

- 6** Close the cover of the fuser unit and press down the levers at both ends of the fuser unit.

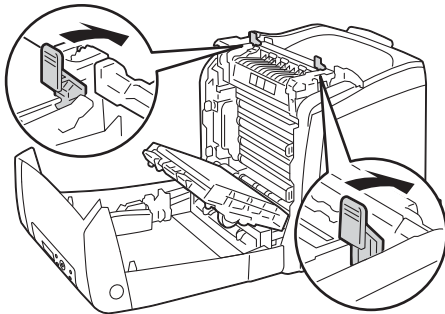

- 7** Confirm that there are no scraps of paper remaining inside the printer, and then close the belt unit.

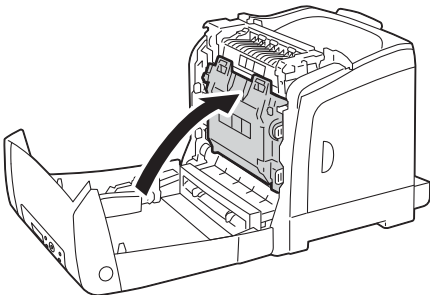

- 8** Close the front cover.

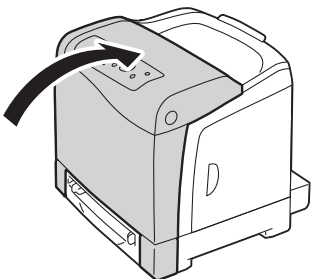

## ■ Clearing Paper Jams From the Duplexer

### NOTE:

- To resolve the error displayed on the LCD panel, you must clear all print media from the print media path.

- 1 Push the side button to open the front cover.

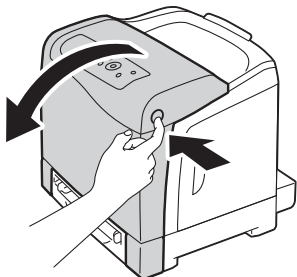

- 2 Open the cover of the duplexer.
- 3 Remove the jammed paper from the duplexer.

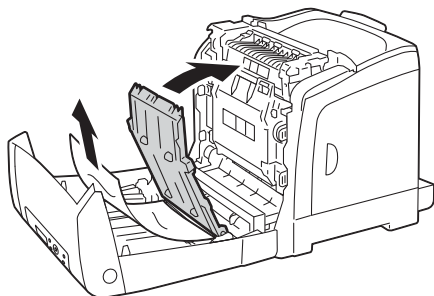

- 4 Close the cover of the duplexer.
- 5 Close the front cover.

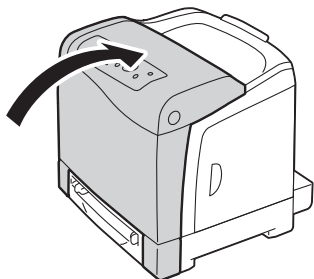

## ■ Clearing Paper Jams From the Optional 250-Sheet Feeder

### NOTE:

- To resolve the error displayed on the LCD panel, you must clear all print media from the print media path.
- 1 Pull the optional 250-sheet feeder out of the printer carefully. Hold the feeder with both hands, and remove it from the printer.

### NOTE:

- Paper in the optional 250-sheet feeder feeds to the printer from the front of the standard 250-sheet tray, therefore paper jammed in the standard 250-sheet tray can block the optional 250-sheet feeder in the printer, preventing you from opening it. Look for the jammed paper sequentially, starting with the optional 250-sheet feeder.

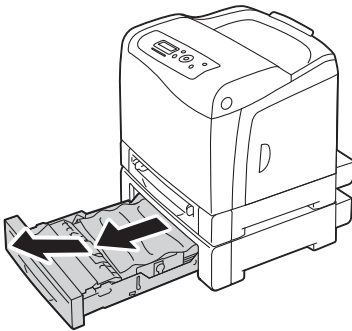

- 2 Remove all jammed and/or creased paper from the feeder.

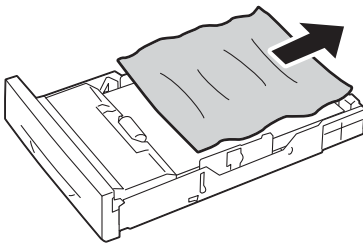

- 3 Pull the jammed paper out carefully to avoid tearing it. If you cannot remove the paper, go to the next step to remove the jammed paper from the inside of the printer.

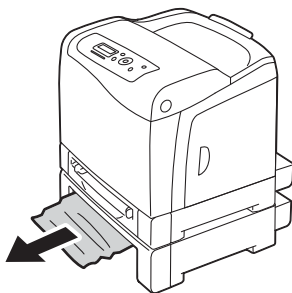

- 4 Push the side button to open the front cover.

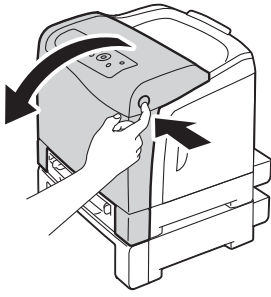

- 5** Open the belt unit until it stops and remove the jammed paper. Confirm that there are no scraps of paper remaining inside the printer.

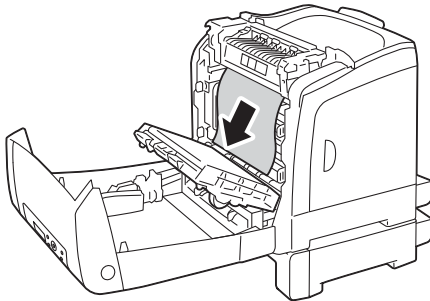
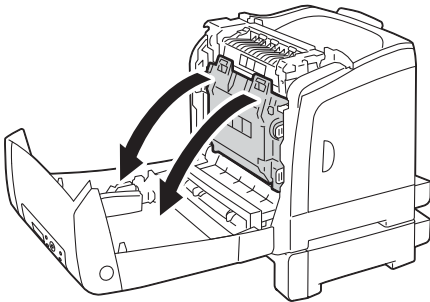

- 6** Close the belt unit, and push at the top of the unit until it clicks.

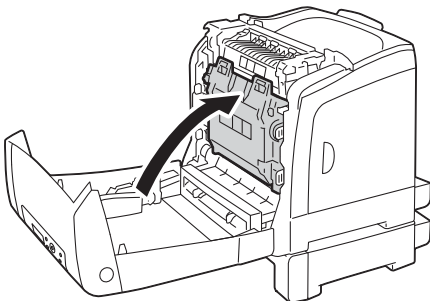

- 7** Close the front cover.

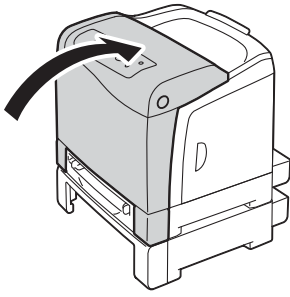

**NOTE:**

- If the paper jam message is not cleared after you close the front cover, pull out the standard 250-sheet tray and check if there is a jammed paper in the opening of the tray.

- 8** Insert the optional 250-sheet feeder into the printer, and push until it stops.

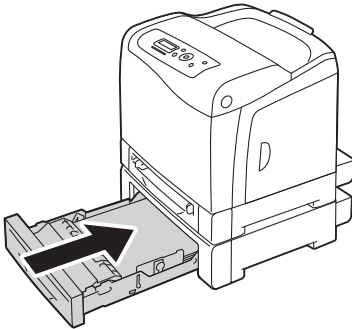

**IMPORTANT:**

- Do not use excessive force on the tray. Doing so could damage the tray or the inside of the printer.

## ■ Jam Problems

This section includes:

- ["Standard 250-Sheet Tray Misfeed Jam" on page 195](#)
- ["SSF Misfeed Jam" on page 196](#)
- ["Optional 250-Sheet Feeder Misfeed Jam" on page 197](#)
- ["Regi Jam \(Exit Sensor On JAM\)" on page 197](#)
- ["Exit Jam \(Exit Sensor Off JAM\)" on page 198](#)
- ["Standard 250-Sheet Tray/Optional 250-Sheet Feeder Multi-feed Jam" on page 198](#)
- ["SSF Multi-feed Jam" on page 198](#)

### Standard 250-Sheet Tray Misfeed Jam

Problem	Action
Print media misfeeds occur in the standard 250-sheet tray.	<p>Ensure that the standard 250-sheet tray is properly inserted.</p> <p>If the problem persists, verify that the correct print media is being used.</p> <hr/> <p>Verify that the correct print media is being used.</p> <p><b>See also:</b></p> <ul style="list-style-type: none"><li>• <a href="#">"Usable Print Media" on page 100</a></li></ul> <p>If not, use the print media recommended for the printer.</p> <p>If the problem persists, ensure that the print media is not damp.</p> <hr/> <p>Ensure that the print media is not curled.</p> <p>If the problem persists, fan the print media.</p> <hr/> <p>Ensure that the print media is not damp.</p> <p>If the print media is damp, turn over the print media.</p> <p>If the problem persists, use print media that is not damp.</p> <p>If the print media is not damp, fan the print media.</p> <hr/> <p>Fan the print media.</p> <p>If the problem persists, wipe the feed roller in the standard 250-sheet tray with a cloth moistened with water.</p> <hr/> <p>Wipe the feed roller in the standard 250-sheet tray with a cloth moistened with water.</p> <p>If the problem persists, replace the drum cartridge if you have a spare cartridge.</p> <hr/> <p>Replace the drum cartridge if you have a spare cartridge.</p> <p>If the problem persists, contact the Fuji Xerox local representative office or an authorised dealer.</p>



## SSF Misfeed Jam

Problem	Action
Print media misfeeds occur in the SSF.	<p data-bbox="541 227 975 253">Ensure that the SSF is properly inserted.</p> <p data-bbox="541 266 1229 324">If the problem persists, verify that the correct print media is being used.</p> <hr/> <p data-bbox="541 338 1048 363">Verify that the correct print media is being used.</p> <p data-bbox="541 388 659 413"><b>See also:</b></p> <ul data-bbox="550 426 938 452" style="list-style-type: none"><li data-bbox="550 426 938 452">• <a href="#">"Usable Print Media" on page 100</a></li></ul> <p data-bbox="541 465 1126 490">If not, use the print media recommended for the printer.</p> <p data-bbox="541 504 1212 529">If the problem persists, ensure that the print media is not damp.</p> <hr/> <p data-bbox="541 542 971 568">Ensure that the print media is not curled.</p> <p data-bbox="541 581 996 606">If the problem persists, fan the print media.</p> <hr/> <p data-bbox="541 620 965 645">Ensure that the print media is not damp.</p> <p data-bbox="541 658 1089 683">If the print media is damp, turn over the print media.</p> <p data-bbox="541 697 1136 722">If the problem persists, use print media that is not damp.</p> <p data-bbox="541 736 1067 761">If the print media is not damp, fan the print media.</p> <hr/> <p data-bbox="541 774 755 799">Fan the print media.</p> <p data-bbox="541 813 1240 871">If the problem persists, wipe the feed roller in the SSF with a cloth moistened with water.</p> <hr/> <p data-bbox="541 884 1232 909">Wipe the feed roller in the SSF with a cloth moistened with water.</p> <p data-bbox="541 923 1269 981">If the problem persists, replace the drum cartridge if you have a spare cartridge.</p> <hr/> <p data-bbox="541 994 1144 1020">Replace the drum cartridge if you have a spare cartridge.</p> <p data-bbox="541 1033 1236 1091">If the problem persists, contact the Fuji Xerox local representative office or an authorised dealer.</p>

## Optional 250-Sheet Feeder Misfeed Jam

Problem	Action
Print media misfeeds occur in the optional 250-sheet feeder.	Ensure that the optional 250-sheet feeder is properly inserted. If the problem persists, ensure that the side cover is closed. Ensure that the side cover is closed. If the problem persists, verify that the correct print media is being used. Verify that the correct print media is being used.
	<b>See also:</b> <ul style="list-style-type: none"><li>• <a href="#">"Usable Print Media" on page 100</a></li></ul>
	If not, use the print media recommended for the printer. If the problem persists, ensure that the print media is not damp. Ensure that the print media is not curled. If the problem persists, fan the print media. Ensure that the print media is not damp. If the print media is damp, turn over the print media. If the problem persists, use print media that is not damp. If the print media is not damp, fan the print media. Fan the print media. If the problem persists, wipe the feed roller in the optional 250-sheet feeder with a cloth moistened with water. Wipe the feed roller in the optional 250-sheet feeder with a cloth moistened with water. If the problem persists, contact the Fuji Xerox local representative office or an authorised dealer.

## Regi Jam (Exit Sensor On JAM)

Problem	Action
Regi jam (Exit Sensor On JAM) occurs.	Ensure that the drum cartridge is installed correctly. If the problem persists, replace the drum cartridge if you have a spare cartridge as instructed in <a href="#">"Replacing the Drum Cartridge" on page 257</a> . Replace the drum cartridge if you have a spare cartridge as instructed in <a href="#">"Replacing the Drum Cartridge" on page 257</a> . If the problem persists, contact the Fuji Xerox local representative office or an authorised dealer.

## Exit Jam (Exit Sensor Off JAM)

Problem	Action
Exit jam (Exit Sensor Off JAM) occurs.	Ensure that the fuser unit is installed correctly. Replace the fuser unit. If the problem persists, contact the Fuji Xerox local representative office or an authorised dealer.

## Standard 250-Sheet Tray/Optional 250-Sheet Feeder Multi-feed Jam

Problem	Action
Print media multiple feeds occur in the standard 250-sheet tray or optional 250-sheet feeder.	Ensure that the tray is properly inserted. If using coated paper, load coated paper one sheet at a time. If using other type of print media, use print media that is not dump. Load coated paper one sheet at a time. If the problem persists, fan the print media. Use print media that is not dump. If the problem persists, fan the print media. Fan the print media. If the problem persists, wipe the feed roller in the tray where the multifeed occurred with a cloth moistened with water. Wipe the feed roller in the tray where the multifeed occurred with a cloth moistened with water. If the problem persists, contact the Fuji Xerox local representative office or an authorised dealer.

## SSF Multi-feed Jam

Problem	Action
Print media multiple feeds occur in the SSF.	Ensure that the media type you are using. If using coated paper, load coated paper one sheet at a time. If using other type of print media, use print media that is not dump. Load coated paper one sheet at a time. If the problem persists, fan the print media. Use print media that is not dump. If the problem persists, fan the print media. Fan the print media. If the problem persists, wipe the feed roller in the tray where the multifeed occurred with a cloth moistened with water. Wipe the feed roller in the tray where the multifeed occurred with a cloth moistened with water. If the problem persists, contact the Fuji Xerox local representative office or an authorised dealer.

# Basic Printer Problems

---

Some printer problems can be easily resolved. If a problem occurs with your printer, check each of the following:

- The power cord is connected to the printer, and to a properly grounded electrical outlet.
- The printer is turned on.
- The electrical outlet is not turned off at any switch or breaker.
- Other electrical equipment plugged into the outlet is working.
- The optional memory module is properly installed.

If you have checked all of the above and still have a problem, turn off the printer, wait for 10 seconds, and then turn on the printer. This often fixes the problem.

# Display Problems

---

Problem	Action
After the printer is turned on, the display on the LCD panel is blank, keeps showing <b>Please wait...</b> , or the back light is not lit.	Turn off the printer, wait for 10 seconds, and turn on the printer. Self Test Message appears on the LCD panel. When the test is completed, <i>Ready</i> is displayed.
Menu settings changed from the operator panel have no effect.	Settings in the software program, the print driver, or the printer utilities have precedence over the settings made on the operator panel.

# Printing Problems

---

Problem	Action
Job did not print or incorrect characters printed.	<p>Ensure that the top menu appears on the LCD panel before you send a job to print. Press the <b>Menu</b> button to return to the top menu.</p> <p>Ensure that the print media is loaded in the printer. Press the <b>Menu</b> button to return to the top menu.</p> <p>Verify that you are using the correct print driver.</p> <p>Ensure that the correct USB or Ethernet cable is securely connected to the printer.</p> <p>Verify that the correct print media size is selected.</p> <p>If you are using a print spooler, verify that the spooler has not stalled.</p> <p>Check the printer's interface from the <code>Admin Menu</code>.</p> <p>Determine the host interface you are using. Print a panel settings page to verify that the current interface settings are correct.</p>
Print media misfeeds or multiple feeds occur in the standard 250-sheet tray or SSF.	<p>Ensure that the print media you are using meets the specifications for your printer.</p> <p><b>See also:</b></p> <ul style="list-style-type: none"><li>• <a href="#">"Usable Print Media" on page 100</a></li></ul> <p>Fan the print media before loading it in the standard 250-sheet tray.</p> <p>Ensure that the print media is loaded correctly.</p> <p>Ensure that the width and length guides of the print media sources are adjusted correctly.</p> <p>Ensure that the standard 250-sheet tray is securely inserted.</p> <p>Do not overload the tray.</p> <p>Do not force print media into the SSF when you load it; otherwise, it may skew or buckle.</p> <p>Ensure that the print media is not curled.</p> <p>Face the recommended print side up or down appropriately for the type of print media you are using.</p> <p><b>See also:</b></p> <ul style="list-style-type: none"><li>• <a href="#">"Loading Print Media" on page 103</a></li></ul> <p>Turn the print media over or around and try printing again to see if feeding improves.</p> <p>Do not mix print media types.</p> <p>Do not mix reams of print media.</p> <p>Remove the top and bottom curled sheets of a ream before loading the print media.</p> <p>Load print media only when the tray is empty.</p> <p>Wipe the feed roller in the standard 250-sheet tray or SSF with a cloth moistened with water.</p> <p>Replace the feed roller.</p>
The envelope is creased after printed.	<p>Make sure that the envelope is loaded in the standard 250-sheet tray or SSF as instructed in <a href="#">"Loading Envelope in the Standard 250-Sheet Tray" on page 107</a> or <a href="#">"Loading Envelope in the Single Sheet Feeder (SSF)" on page 111</a>.</p>

---

<b>Problem</b>	<b>Action</b>
Page breaks in unexpected places.	Increase the value for the time-out on the operator panel or CentreWare Internet Services.
Print media does not stack neatly in the output bin.	Turn the print media stack over in the tray.
Cannot print from the standard 250-sheet tray because the print media in the tray is curled.	Load the print media into the SSF.

---

# Print Quality Problems

---

This section includes:

- ["The Output Is Too Light"](#) on page 204
- ["Toner Smears or Print Comes Off"](#) on page 206
- ["Random Spots/Blurred Images"](#) on page 207
- ["The Entire Output Is Blank"](#) on page 208
- ["Streaks Appear on the Output"](#) on page 210
- ["Part or the Entire Output Is Black"](#) on page 211
- ["Pitched Color Dots"](#) on page 212
- ["Vertical Blanks"](#) on page 213
- ["Ghosting"](#) on page 215
- ["Light-Induced Fatigue"](#) on page 216
- ["Fog"](#) on page 217
- ["Bead-Carry-Out \(BCO\)"](#) on page 218
- ["Jagged Characters"](#) on page 219
- ["Banding"](#) on page 220
- ["Auger Mark"](#) on page 221
- ["Wrinkled/Stained Paper"](#) on page 222
- ["Damage on the Leading Edge of Paper"](#) on page 223

## NOTE:

- In this section, some procedures use the operator panel or CentreWare Internet Services.

## See also:

- ["Understanding the Printer Menus"](#) on page 142
- ["CentreWare Internet Services"](#) on page 53



## ■ The Output Is Too Light

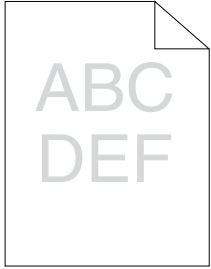

Problem	Action
The output is too light.	<p>The toner cartridges may be low or need to be replaced. Confirm the amount of toner in each toner cartridge.</p>
	<ol style="list-style-type: none"> <li>1 Check the toner level in the Printer Status window.</li> <li>2 Replace the toner cartridges as necessary.</li> </ol>
	<p>If the problem persists, disable Draft Mode in the print driver.</p>
	<p>Disable Draft Mode in the print driver. The following procedure uses the PCL 6 driver as an example.</p>
	<ol style="list-style-type: none"> <li>1 On the <b>Advanced Settings</b> tab, ensure that the <b>Draft Mode</b> check box is not selected.</li> </ol>
	<p>If the problem persists, try changing the Paper Type setting in the print driver.</p>
	<p>The print media surface may be uneven. Try changing the Paper Type setting in the print driver. For example, change the plain paper to heavy using a PCL 6 driver.</p>
	<ol style="list-style-type: none"> <li>1 On the <b>Paper / Output</b> tab, change the Paper Type setting.</li> </ol>
	<p>If the problem persists, verify that the correct print media is being used.</p>
	<p>Verify that the correct print media is being used.</p>
	<p><b>See also:</b></p>
	<ul style="list-style-type: none"> <li>• <a href="#">"Usable Print Media" on page 100</a></li> </ul>
	<p>If not, use the print media recommended for the printer.</p>
	<p>If the problem persists, ensure that the eight yellow ribbons are correctly removed from the drum cartridge.</p>
	<p>Ensure that the eight yellow ribbons are correctly removed from the drum cartridge.</p>
	<p><b>See also:</b></p>
	<ul style="list-style-type: none"> <li>• <a href="#">"Installing a Toner Cartridge" on page 255</a></li> <li>• <a href="#">"Installing the Drum Cartridge" on page 260</a></li> </ul>
	<p>If not, remove the ribbons.</p>
	<p>If the problem persists, replace the drum cartridge if you have a spare cartridge.</p>
	<p>Replace the drum cartridge if you have a spare cartridge.</p>
	<p><b>See also:</b></p>
	<ul style="list-style-type: none"> <li>• <a href="#">"Replacing the Drum Cartridge" on page 257</a></li> <li>• <a href="#">"Installing the Drum Cartridge" on page 260</a></li> </ul>
	<p>If the problem persists, contact the Fuji Xerox local representative office or an authorised dealer.</p>

## ■ Toner Smears or Print Comes Off

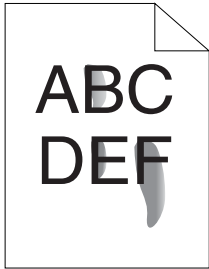

Problem	Action
Toner smears or print comes off.	<p>The print media surface may be uneven. Try changing the Paper Type setting in the print driver. For example, change the plain paper to heavy using a PCL 6 driver.</p> <ol style="list-style-type: none"><li data-bbox="552 610 1199 635">1 On the <b>Paper / Output</b> tab, change the Paper Type setting.</li></ol> <p>If the problem persists, verify that the correct print media is being used.</p> <hr/> <p>Verify that the correct print media is being used.</p> <p><b>See also:</b></p> <ul style="list-style-type: none"><li data-bbox="552 807 938 832">• <a href="#">"Usable Print Media" on page 100</a></li></ul> <p>If not, use the print media recommended for the printer.</p> <p>If the problem persists, replace the drum cartridge if you have a spare cartridge.</p> <hr/> <p>Replace the drum cartridge if you have a spare cartridge.</p> <ol style="list-style-type: none"><li data-bbox="552 991 865 1016">1 Replace the drum cartridge.</li></ol> <p><b>See also:</b></p> <ul style="list-style-type: none"><li data-bbox="552 1078 1050 1103">• <a href="#">"Replacing the Drum Cartridge" on page 257</a></li><li data-bbox="552 1112 1039 1137">• <a href="#">"Installing the Drum Cartridge" on page 260</a></li></ul> <ol style="list-style-type: none"><li data-bbox="552 1151 1222 1205">2 After you replace the drum cartridge, test print your document again.</li></ol> <p>If the problem persists, contact the Fuji Xerox local representative office or an authorised dealer.</p>

## ■ Random Spots/Blurred Images

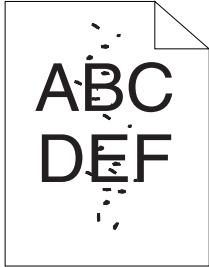

Problem	Action
The printed result has random spots or is blurred.	<p data-bbox="543 517 1115 542">Ensure that the toner cartridges are installed correctly.</p> <p data-bbox="543 571 659 596"><b>See also:</b></p> <ul data-bbox="550 606 1023 631" style="list-style-type: none"><li data-bbox="550 606 1023 631">• <a href="#">"Installing a Toner Cartridge" on page 255</a></li></ul> <p data-bbox="543 645 1229 703">If the problem persists, ensure that the drum cartridge is installed correctly.</p> <hr/> <p data-bbox="543 716 1085 741">Ensure that the drum cartridge is installed correctly.</p> <p data-bbox="543 770 659 795"><b>See also:</b></p> <ul data-bbox="550 805 1050 869" style="list-style-type: none"><li data-bbox="550 805 1050 830">• <a href="#">"Replacing the Drum Cartridge" on page 257</a></li><li data-bbox="550 840 1039 865">• <a href="#">"Installing the Drum Cartridge" on page 260</a></li></ul> <p data-bbox="543 879 1270 937">If the problem persists, replace the drum cartridge if you have a spare cartridge.</p> <hr/> <p data-bbox="543 950 1146 975">Replace the drum cartridge if you have a spare cartridge.</p> <p data-bbox="543 1004 659 1029"><b>See also:</b></p> <ul data-bbox="550 1039 1050 1103" style="list-style-type: none"><li data-bbox="550 1039 1050 1064">• <a href="#">"Replacing the Drum Cartridge" on page 257</a></li><li data-bbox="550 1074 1039 1099">• <a href="#">"Installing the Drum Cartridge" on page 260</a></li></ul> <p data-bbox="543 1112 1236 1170">If the problem persists, contact the Fuji Xerox local representative office or an authorised dealer.</p>

## ■ The Entire Output Is Blank

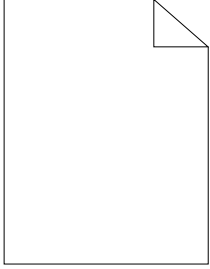

Problem	Action
The entire output is blank.	<p>The toner cartridges may be low or need to be replaced. Confirm the amount of toner in each toner cartridge.</p> <ol style="list-style-type: none"> <li>1 Check the toner level in the Printer Status window.</li> <li>2 Replace the toner cartridges as necessary.</li> </ol> <p>If the problem persists, disable Draft Mode in the print driver.</p> <hr/> <p>Disable Draft Mode in the print driver. The following procedure uses the PCL 6 driver as an example.</p> <ol style="list-style-type: none"> <li>1 On the <b>Advanced Settings</b> tab, ensure that the <b>Draft Mode</b> check box is not selected.</li> </ol> <p>If the problem persists, try changing the Paper Type setting in the print driver.</p> <hr/> <p>The print media surface may be uneven. Try changing the Paper Type setting in the print driver. For example, change the plain paper to heavy using the PCL 6 driver.</p> <ol style="list-style-type: none"> <li>1 On the <b>Paper / Output</b> tab, change the Paper Type setting.</li> </ol> <p>If the problem persists, verify that the correct print media is being used.</p> <hr/> <p>Verify that the correct print media is being used.</p> <p><b>See also:</b></p> <ul style="list-style-type: none"> <li>• <a href="#">"Usable Print Media" on page 100</a></li> </ul> <p>If not, use the print media recommended for the printer.</p> <p>If the problem persists, ensure that the eight yellow ribbons are correctly removed from the drum cartridge.</p> <hr/> <p>Ensure that the eight yellow ribbons are correctly removed from the drum cartridge.</p> <p><b>See also:</b></p> <ul style="list-style-type: none"> <li>• <a href="#">"Installing a Toner Cartridge" on page 255</a></li> <li>• <a href="#">"Installing the Drum Cartridge" on page 260</a></li> </ul> <p>If not, remove the ribbons.</p> <p>If the problem persists, replace the drum cartridge if you have a spare cartridge.</p> <hr/> <p>Replace the drum cartridge if you have a spare cartridge.</p> <p><b>See also:</b></p> <ul style="list-style-type: none"> <li>• <a href="#">"Replacing the Drum Cartridge" on page 257</a></li> <li>• <a href="#">"Installing the Drum Cartridge" on page 260</a></li> </ul> <p>If the problem persists, contact the Fuji Xerox local representative office or an authorised dealer.</p>

## ■ Streaks Appear on the Output

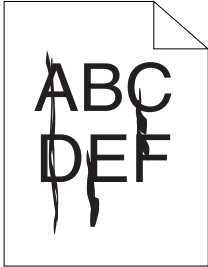

Problem	Action
Streaks appear on the output.	<p>The toner cartridges may be low or need to be replaced. Confirm the amount of toner in each toner cartridge.</p> <ol style="list-style-type: none"><li data-bbox="552 581 1105 606">1 Check the toner level in the Printer Status window.</li><li data-bbox="552 616 1023 641">2 Replace the toner cartridges as necessary.</li></ol> <p>If the problem persists, replace the drum cartridge if you have a spare cartridge.</p> <hr/> <p>Replace the drum cartridge if you have a spare cartridge.</p> <p><b>See also:</b></p> <ul style="list-style-type: none"><li data-bbox="552 813 1050 838">• <a href="#">"Replacing the Drum Cartridge" on page 257</a></li><li data-bbox="552 848 1039 873">• <a href="#">"Installing the Drum Cartridge" on page 260</a></li></ul> <p>If the problem persists, contact the Fuji Xerox local representative office or an authorised dealer.</p>

## ■ Part or the Entire Output Is Black

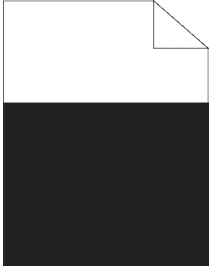

Problem	Action
Part or the entire output is black.	<p>Ensure <b>Output Color</b> is set to <b>Color</b> in the print driver. The following procedure uses the PCL 6 driver as an example.</p> <ol style="list-style-type: none"><li data-bbox="552 581 1270 633">1 On the <b>Image Options</b> tab, ensure that the <b>Output Color</b> is set to <b>Color</b>.</li></ol> <p>If the problem persists, replace the drum cartridge if you have a spare cartridge.</p> <hr/> <p>Replace the drum cartridge if you have a spare cartridge.</p> <p><b>See also:</b></p> <ul style="list-style-type: none"><li data-bbox="552 807 1050 832">• <a href="#">"Replacing the Drum Cartridge" on page 257</a></li><li data-bbox="552 846 1039 871">• <a href="#">"Installing the Drum Cartridge" on page 260</a></li></ul> <p>If the problem persists, contact the Fuji Xerox local representative office or an authorised dealer.</p>



## ■ Pitched Color Dots

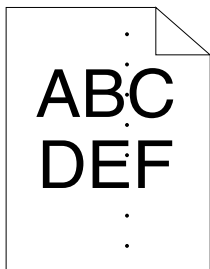

---

**Problem**

The printed result has pitched color dots.

**Action**

Replace the drum cartridge if you have a spare cartridge.

**See also:**

- ["Replacing the Drum Cartridge" on page 257](#)
- ["Installing the Drum Cartridge" on page 260](#)

If the problem persists, contact the Fuji Xerox local representative office or an authorised dealer.

---

## ■ Vertical Blanks

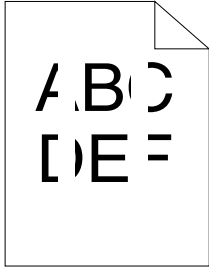

Problem	Action
The printed result has vertical blanks.	<p data-bbox="543 517 924 542">Ensure the light path is not covered.</p> <ol data-bbox="552 552 1181 581" style="list-style-type: none"><li data-bbox="552 552 1181 581">1 Remove the drum cartridge, and keep it in the dark place.</li></ol> <p data-bbox="543 604 659 629"><b>See also:</b></p> <ul data-bbox="552 639 1122 739" style="list-style-type: none"><li data-bbox="552 639 1053 668">• <a href="#">"Replacing the Drum Cartridge" on page 257</a></li><li data-bbox="552 678 1122 707">2 Check the light path, and then remove the shielding.</li><li data-bbox="552 716 879 739">3 Re-install the drum cartridge.</li></ul> <p data-bbox="543 765 659 790"><b>See also:</b></p> <ul data-bbox="552 799 1039 828" style="list-style-type: none"><li data-bbox="552 799 1039 828">• <a href="#">"Installing the Drum Cartridge" on page 260</a></li></ul> <p data-bbox="543 838 1270 896">If the problem persists, replace the drum cartridge if you have a spare cartridge.</p> <hr/> <p data-bbox="543 909 1146 935">Replace the drum cartridge if you have a spare cartridge.</p> <p data-bbox="543 960 659 985"><b>See also:</b></p> <ul data-bbox="552 994 1053 1060" style="list-style-type: none"><li data-bbox="552 994 1053 1023">• <a href="#">"Replacing the Drum Cartridge" on page 257</a></li><li data-bbox="552 1033 1039 1060">• <a href="#">"Installing the Drum Cartridge" on page 260</a></li></ul> <p data-bbox="543 1070 1238 1128">If the problem persists, contact the Fuji Xerox local representative office or an authorised dealer.</p>

## ■ Mottle

---

Problem	Action
The printed result has mottled appearance.	Verify that the print media recommended for the printer is being used. If you use non-recommended print media, use the print media recommended for the printer. If the problem persists, contact the Fuji Xerox local representative office or an authorised dealer.

---

## ■ Ghosting

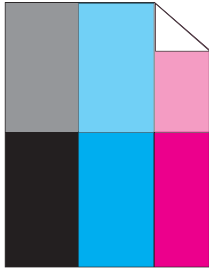

Problem	Action
The printed result has ghosting.	<p>If the type of the ghosting is positive ghost: Replace the drum cartridge if you have a spare cartridge.</p> <p><b>See also:</b></p> <ul style="list-style-type: none"><li>• <a href="#">"Replacing the Drum Cartridge" on page 257</a></li><li>• <a href="#">"Installing the Drum Cartridge" on page 260</a></li></ul> <p>If the problem persists, contact the Fuji Xerox local representative office or an authorised dealer.</p> <hr/> <p>If the type of the ghosting is negative ghost: Verify that the print media recommended for the printer is being used. If you are using non-recommended print media, use the print media recommended for the printer. If the problem is solved, adjust the transfer bias. If the problem persists, replace the drum cartridge if you have a spare cartridge.</p> <hr/> <p>Adjust the transfer bias.</p> <ol style="list-style-type: none"><li>1 On the operator panel, press the <b>Menu</b> button and select <code>Admin Menu</code> → <code>Maintenance Mode</code> → <code>Adjust BTR</code>.</li><li>2 Adjust the setting for the type of print media being used.</li></ol> <p>If the problem persists, contact the Fuji Xerox local representative office or an authorised dealer.</p>

## ■ Light-Induced Fatigue

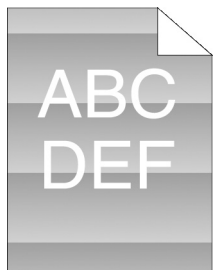

---

Problem	Action
The printed result has light-induced fatigue pattern.	Replace the drum cartridge if you have a spare cartridge.  <b>See also:</b> <ul data-bbox="550 604 1053 672" style="list-style-type: none"><li>• <a href="#">"Replacing the Drum Cartridge" on page 257</a></li><li>• <a href="#">"Installing the Drum Cartridge" on page 260</a></li></ul> If the problem persists, contact the Fuji Xerox local representative office or an authorised dealer.

---

## ■ Fog



---

Problem	Action
The printed result is foggy.	Replace the drum cartridge if you have a spare cartridge.  <b>See also:</b> <ul style="list-style-type: none"><li data-bbox="550 606 1050 631">• <a href="#">"Replacing the Drum Cartridge" on page 257</a></li><li data-bbox="550 643 1039 668">• <a href="#">"Installing the Drum Cartridge" on page 260</a></li></ul> If the problem persists, contact the Fuji Xerox local representative office or an authorised dealer.

---

## ■ Bead-Carry-Out (BCO)

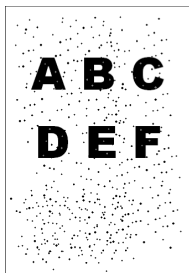

Problem	Action
Bead-Carry-Out (BCO) is happening.	Replace the drum cartridge if you have a spare cartridge.  <b>See also:</b> <ul data-bbox="550 610 1053 672" style="list-style-type: none"><li>• <a href="#">"Replacing the Drum Cartridge" on page 257</a></li><li>• <a href="#">"Installing the Drum Cartridge" on page 260</a></li></ul> If the problem persists, contact the Fuji Xerox local representative office or an authorised dealer.

## ■ Jagged Characters

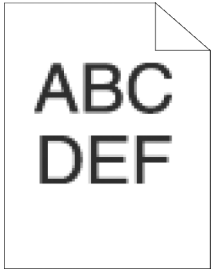

Problem	Action
The printed result has jagged characters.	<p>Set <b>Screen</b> to <b>Fineness</b> in the print driver. The following procedure uses the PCL 6 driver as an example.</p> <ol style="list-style-type: none"><li>1 On the <b>Advanced Settings</b> tab, set <b>Screen</b> under <b>Items:</b> to <b>Fineness</b>.</li></ol> <p>If the problem persists, set <b>Image Quality</b> to <b>High Quality</b> in the print driver.</p>
	<p>Set <b>Image Quality</b> to <b>High Quality</b> in the print driver. The following procedure uses the PCL 6 driver as an example.</p> <ol style="list-style-type: none"><li>1 On the <b>Image Options</b> tab, select <b>High Quality</b> from <b>Image Quality</b>.</li></ol> <p>If the problem persists, enable <b>Bitmap Smoothing</b> in the print driver.</p>
	<p>Enable <b>Bitmap Smoothing</b> in the print driver. The following procedure uses the PCL 6 driver as an example.</p> <ol style="list-style-type: none"><li>1 On the <b>Advanced Settings</b> tab, set <b>Bitmap Smoothing</b> under <b>Items:</b> to <b>On</b>.</li></ol> <p>If the problem persists, enable <b>Bitmap Text Smoothing</b> in the print driver.</p>
	<p>Enable <b>Bitmap Text Smoothing</b> in the print driver. The following procedure uses the PCL 6 driver as an example.</p> <ol style="list-style-type: none"><li>1 On the <b>Advanced Settings</b> tab, set <b>Bitmap Text Smoothing</b> under <b>Items:</b> to <b>On</b>.</li></ol> <p>If the problem persists, check whether or not the downloaded font you are using is recommended.</p>
	<p>If using a downloaded font, ensure that the font is recommended for the printer, operating system, and the application being used.</p> <p>If the problem persists, contact the Fuji Xerox local representative office or an authorised dealer.</p>



## ■ Banding

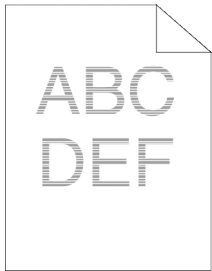

---

Problem	Action
The printed result has banding.	Replace the drum cartridge if you have a spare cartridge.  <b>See also:</b> <ul style="list-style-type: none"><li data-bbox="550 606 1050 631">• <a href="#">"Replacing the Drum Cartridge" on page 257</a></li><li data-bbox="550 643 1039 668">• <a href="#">"Installing the Drum Cartridge" on page 260</a></li></ul> If the problem persists, contact the Fuji Xerox local representative office or an authorised dealer.

---

## ■ Auger Mark

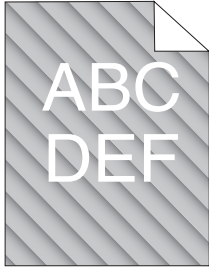

---

Problem	Action
The printed result has auger mark.	Replace the drum cartridge if you have a spare cartridge.  <b>See also:</b> <ul style="list-style-type: none"><li data-bbox="550 606 1050 631">• <a href="#">"Replacing the Drum Cartridge" on page 257</a></li><li data-bbox="550 643 1039 668">• <a href="#">"Installing the Drum Cartridge" on page 260</a></li></ul> If the problem persists, contact the Fuji Xerox local representative office or an authorised dealer.

---

## ■ Wrinkled/Stained Paper

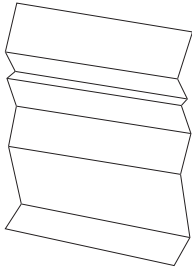

Problem	Action
The output is wrinkled. The output is stained.	<p data-bbox="543 517 1048 540">Verify that the correct print media is being used.</p> <p data-bbox="543 571 659 595"><b>See also:</b></p> <ul data-bbox="550 604 938 668" style="list-style-type: none"><li data-bbox="550 604 938 627">• <a href="#">"Usable Print Media" on page 100</a></li><li data-bbox="550 639 913 662">• <a href="#">"About Print Media" on page 94</a></li></ul> <p data-bbox="543 681 1126 705">If not, use the print media recommended for the printer.</p> <p data-bbox="543 722 1270 774">If the problem with printing on an envelope persists, check the wrinkle of the envelope.</p> <p data-bbox="543 792 1232 871">If the problem with printing on a print media other than envelopes persists, contact the Fuji Xerox local representative office or an authorised dealer.</p> <hr/> <p data-bbox="543 888 1270 940">Check whether the wrinkle of the four edges of the envelope is within 30 mm.</p> <p data-bbox="543 958 1256 1010">If the wrinkle of the four edges of the envelope is within 30 mm, this type of wrinkle is considered normal. Your printer is not at fault.</p> <p data-bbox="543 1027 842 1051">If not, take following actions:</p> <ul data-bbox="550 1060 1263 1267" style="list-style-type: none"><li data-bbox="550 1060 1236 1139">• If the envelope is 220 mm or longer (C5 or Com-10), load the envelope in the standard 250-sheet tray in the short edge feed orientation with the flap closed and print side up.</li><li data-bbox="550 1151 1263 1267">• If the envelope is shorter than 220 mm (Monarch or DL), load the envelope in the standard 250-sheet tray in the short edge feed orientation with the flap closed and print side up, or in the long edge feed orientation with the flap open and print side up.</li></ul> <hr/> <p data-bbox="543 1284 1263 1336">Load the envelopes in the standard 250-sheet tray in the short edge feed orientation with the flap closed and print side up.</p> <p data-bbox="543 1363 659 1387"><b>See also:</b></p> <ul data-bbox="550 1396 1263 1420" style="list-style-type: none"><li data-bbox="550 1396 1263 1420">• <a href="#">"Loading Envelope in the Standard 250-Sheet Tray" on page 107</a></li></ul> <p data-bbox="543 1437 1236 1489">If the problem persists, contact the Fuji Xerox local representative office or an authorised dealer.</p> <hr/> <p data-bbox="543 1506 1256 1559">Load the envelopes in the standard 250-sheet tray in the long edge feed orientation with the flap open and print side up.</p> <p data-bbox="543 1586 659 1609"><b>See also:</b></p> <ul data-bbox="550 1619 893 1642" style="list-style-type: none"><li data-bbox="550 1619 893 1642">• <a href="#">"Monarch or DL" on page 108</a></li></ul> <p data-bbox="543 1659 1236 1711">If the problem persists, contact the Fuji Xerox local representative office or an authorised dealer.</p>

## ■ Damage on the Leading Edge of Paper

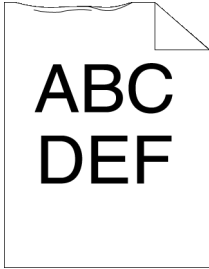

Problem	Action
The output is damaged on its leading edge.	<p>When using the SSF, reverse the paper and then try again.</p> <p>If the problem persists, change the paper with another one and then try again.</p> <p>When using the standard 250-sheet tray or optional 250-sheet feeder, change the paper and then try again.</p> <p>If the problem persists, contact the Fuji Xerox local representative office or an authorised dealer.</p>
	<p>Change the paper with another one and then try again.</p> <p>If the problem persists, use the standard 250-sheet tray or optional 250-sheet feeder in place of the SSF.</p>
	<p>Use the standard 250-sheet tray or optional 250-sheet feeder in place of the SSF.</p> <p>If the problem persists, contact the Fuji Xerox local representative office or an authorised dealer.</p>

## ■ The Top and Side Margins Are Incorrect

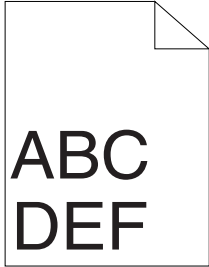



---

Problem	Action
The top and side margins are incorrect.	Ensure that the margins are set correctly on the application being used.  If the problem persists, contact the Fuji Xerox local representative office or an authorised dealer.

---

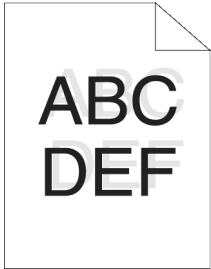
## ■ Color Registration Is out of Alignment



Problem	Action
Color registration is out of alignment.	<p data-bbox="543 517 996 542">Execute auto color registration adjustment.</p> <p data-bbox="552 552 1256 639">1 On the operator panel, press the <b>Menu</b> button and select <code>Admin Menu</code> → <code>Maintenance Mode</code> → <code>Adjust ColorRegi</code> → <code>Auto Adjust</code>, and then press the  button.</p> <p data-bbox="543 649 1263 707">If the problem persists, check whether or not you have a spare drum cartridge.</p> <hr/> <p data-bbox="543 716 1126 741">Check whether or not you have a spare drum cartridge.</p> <p data-bbox="543 755 1201 780">If you have a spare drum cartridge, replace the drum cartridge.</p> <p data-bbox="543 794 1270 852">If you do not have a spare drum cartridge, contact the Fuji Xerox local representative office or an authorised dealer.</p> <hr/> <p data-bbox="543 861 1146 886">Replace the drum cartridge if you have a spare cartridge.</p> <p data-bbox="543 915 659 940"><b>See also:</b></p> <ul data-bbox="552 950 1050 1018" style="list-style-type: none"><li>• <a href="#">"Replacing the Drum Cartridge" on page 257</a></li><li>• <a href="#">"Installing the Drum Cartridge" on page 260</a></li></ul> <p data-bbox="543 1027 1236 1085">If the problem persists, contact the Fuji Xerox local representative office or an authorised dealer.</p>

## ■ Protrudent/Bumpy Paper

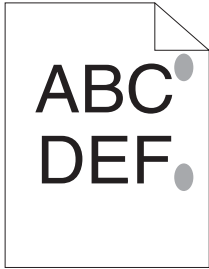

Problem	Action
Printed surface got protrudent/bumpy.	Clean up the fuser unit. <b>1</b> Load one sheet of paper on the SSF, and then print a solid image all over paper. <b>2</b> Load the printed sheet with the side to be printed on facing down, and then print a blank sheet of paper. If the problem persists, contact the Fuji Xerox local representative office or an authorised dealer.

# Adjusting Color Registration

---

This section describes how to adjust the color registration when you first install the printer or after moving it to a new location.

This section includes:





- ["Performing Auto Adjust" on page 228](#)
- ["Printing the Color Registration Chart" on page 229](#)
- ["Determining Values" on page 230](#)
- ["Entering Values" on page 231](#)



## ■ Performing Auto Adjust

Auto Adjust allows you to correct the color registration automatically.

### The Operator Panel

- 1 Press the **Menu** button.
- 2 Select `Admin Menu`, and then press the  button.
- 3 Select `Maintenance Mode`, and then press the  button.
- 4 Select `Adjust ColorRegi`, and then press the  button.
- 5 Select `Auto Adjust`, and then press the  button.
- 6 Ensure that `Are You Sure?` appears, and then press the  button.  
Auto adjust is performed.

## ■ Printing the Color Registration Chart

- 1 Press the **Menu** button.
- 2 Select `Admin Menu`, and then press the **OK** button.
- 3 Select `Maintenance Mode`, and then press the **OK** button.
- 4 Select `Adjust ColorRegi`, and then press the **OK** button.
- 5 Select `ColorRegi Chart`, and then press the **OK** button.
- 6 Ensure that `Are You Sure?` appears, and then press the **OK** button.  
The color registration chart is printed.

## ■ Determining Values

On the color registration chart, there are two types of charts: Chart 1 (fast scan) and Chart 2 (slow scan).

The Chart 1 is used to adjust the color registration for the fast scan direction, which is vertical to paper feed direction. The Chart 2 is used to adjust the color registration for the slow scan direction, which is horizontal to paper feed direction.

The following sections explain how to determine the adjustment values for the fast scan and the slow scan using Chart 1 and Chart 2.

### Fast Scan

On the Chart 1 of the color registration chart, find the straightest lines where the two black lines and the colored line are most closely aligned for each color (**Y**, **M**, and **C**). If you find the straightest line, make a note of the value (**-9 to +9**) indicated by the straightest line for each color.

When the value is **0** for each color, you do not need to adjust the color registration for the fast scan.

When the value is not **0**, enter the value using the procedure in ["Entering Values" on page 231](#).

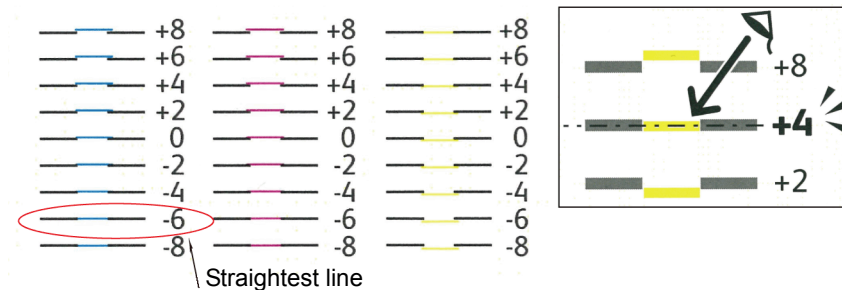

### Slow Scan

On the Chart 2 of the color registration chart, find the medium line within the range of white area for each color pattern (**Y**, **M**, and **C**). If you find the medium line, make a note of the value (**-9 to +9**) indicated by the medium line for each color.

When the value is **0** for each color, you do not need to adjust the color registration for the slow scan.

When the value is not **0**, enter the value using the procedure in ["Entering Values" on page 231](#).

## ■ Entering Values

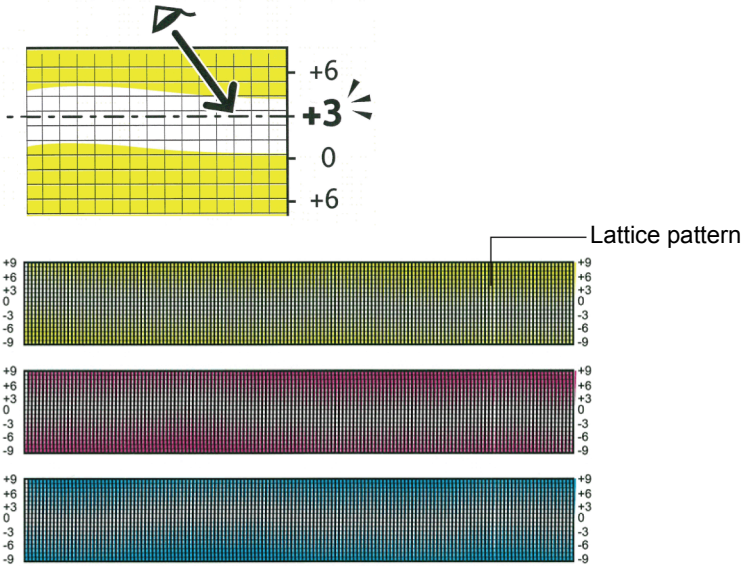

Using the operator panel, enter the values found in the color registration chart to make adjustments.

- 1 Press the **Menu** button.
- 2 Select `Admin Menu`, and then press the **OK** button.
- 3 Select `Maintenance Mode`, and then press the **OK** button.
- 4 Select `Adjust ColorRegi`, and then press the **OK** button.
- 5 Select `Enter Number`, and then press the **OK** button.
- 6 Ensure that `Enter (LY, LM, LC)` appears.
- 7 Press the ▲ or ▼ button to specify the values for LY, LM, and LC.

### NOTE:

- To move the cursor to the next value, press the ► button.

- 8 Press the **OK** button.
- 9 Ensure that `Enter (RY, RM, RC)` appears.
- 10 Press the ▲ or ▼ button to specify the values for RY, RM, and RC.

### NOTE:

- To move the cursor to the next value, press the ► button.

- 11 Press the **OK** button.
- 12 Ensure that `Enter (PY, PM, PC)` appears.
- 13 Press the ▲ or ▼ button to specify the values for PY, PM, and PC.

### NOTE:

- To move the cursor to the next value, press the ► button.

**14** Press the  button.

**15** Select `ColorRegi Chart`, and then press the  button.

**16** Ensure that `Are You Sure?` appears, and then press the  button.

The color registration chart is printed with the new values.

If the straightest line is not at the value of 0, adjust the values again. Checking the charts before and after the adjustments will help you to determine the values to enter.

After printing the color registration chart, do not turn off the printer until the printer motor has stopped running.

**NOTE:**

- If 0 is not next to the straightest lines, determine the values and adjust the printer again.

# Problems With Installed Optional Accessories

---

Problem	Action
The optional 250-sheet feeder does not work correctly.	<p>Ensure that the optional 250-sheet feeder is correctly installed on the printer. Re-install the optional 250-sheet feeder.</p> <p><b>See also:</b></p> <ul style="list-style-type: none"><li>• <a href="#">"Removing the Optional 250-Sheet Feeder" on page 288</a></li><li>• <a href="#">"Installing the Optional 250-Sheet Feeder" on page 42</a></li></ul> <p>If the problem persists, contact customer support.</p> <hr/> <p>Ensure that the print media is loaded correctly.</p> <p><b>See also:</b></p> <ul style="list-style-type: none"><li>• <a href="#">"Loading Print Media in the Standard 250-Sheet Tray and the Optional 250-Sheet Feeder" on page 105</a></li></ul> <p>If the problem persists, contact customer support.</p>
The optional memory module does not work correctly.	<p>Ensure that the optional memory module is securely connected to the memory connector.</p> <p>If the problem persists, contact customer support.</p>

# Other Problems

---





Problem	Action
Condensation has occurred inside the printer.	This usually occurs within several hours after you heat the room in winter. This also occurs when the printer is operating in a location where relative humidity reaches 85% or more. Adjust the humidity or relocate the printer to an appropriate environment.
"092-310", "092-910", or "092-410" is displayed.	Clean the CTD sensor.  <b>See also:</b> <ul style="list-style-type: none"><li>• <a href="#">"Cleaning the Color Toner Density (CTD) Sensor" on page 250</a></li></ul>
No Documents is displayed on the LCD panel when you are selecting a file for Print from USB Memory feature.	Confirm that there are files with the supported file formats (PDF, TIFF, or JPEG) in the USB storage device.  If the target file is in a deep hierarchy in the USB storage device, move the file to the root directory on your computer.  Shorten the target file name in the USB storage device on your computer, and try printing again.

# Understanding Printer Messages

The printer LCD panel displays messages describing the current state of the printer and indicates possible printer problems you must resolve. This section describes messages, their meanings, and how to clear the messages.

## IMPORTANT:

- When an error code is displayed, the print data remaining on the printer and the information accumulated in the memory of the printer are not secured.

Error-Code	What You Can Do
010-317	Turn off the printer and wait for 30 minutes. Open the front cover and make sure that the fuser unit is fully installed.
010-397	Turn off the printer. Confirm that the fuser unit is correctly installed, and turn on the printer. Contact customer support if this failure is repeated.
016-404	Contact your system administrator.
016-405	
016-500	Turn off the printer, and turn it on again. Contact customer support if this failure is repeated.
016-501	
016-502	
016-520	Contact your system administrator.
016-521	
016-522	
016-523	
016-524	
016-527	
016-737	Turn off the printer, and turn it on again. Contact customer support if this failure is repeated.
016-738	
016-741	
016-744	
016-750	Press the  button, or wait for 30 seconds for the printer to recover.
016-753	
016-755	
016-757	The account is not registered. Contact your system administrator.
016-758	The function cannot be used. Contact your system administrator.
016-759	Printable page limit is exceeded. Contact your system administrator.
016-786	Press the  button, or wait for 30 seconds for the printer to recover. Check if the network cable is connected properly. If there is no problem with the network cable, contact server administrator.
016-790	
016-791	Press the  button, or wait for 30 seconds for the printer to recover.
016-799	Press the  button to clear the message and cancel the current print job. Confirm the configuration of the printer on the print driver.
016-930	The device is not supported. Remove it from the USB port.
016-931	The USB hub is not supported. Remove it from the USB port.
024-910	Reload the specified paper on the standard 250-sheet tray.
024-911	Reload the specified paper on the optional 250-sheet feeder.



024-914	Reload the specified paper on the SSF.
024-923	Open the side cover. Remove the used yellow cartridge, and install a new cartridge.
024-924	Open the side cover. Remove the used magenta cartridge, and install a new cartridge.
024-925	Open the side cover. Remove the used cyan cartridge, and install a new cartridge.
024-946	Insert the standard 250-sheet tray.
024-947	Insert the optional 250-sheet feeder.
027-446	Change IP address to avoid duplication. Turn off the printer, and turn it on again.
027-452	
042-700	Wait for a while until the printer cools down.
071-100	Remove the standard 250-sheet tray and jammed paper. Open and close the front cover.
071-920	Set side 2 of the sheet to the standard 250-sheet tray.
071-921	Press the  button.
072-100	Remove the optional 250-sheet feeder and jammed paper. Open and close the front cover.
072-101	Remove the standard 250-sheet tray or the optional 250-sheet feeder, and remove the jammed paper. Open and close the front cover.
072-215	Turn off the printer. Confirm that the optional 250-sheet feeder is correctly installed, and turn on the printer. Contact customer support if this failure is repeated.
072-900	Remove the standard 250-sheet tray or the optional 250-sheet feeder, and remove the jammed paper. Open and close the front cover.
072-920	Set side 2 of the sheet to the optional 250-sheet feeder.
072-921	Press the  button.
075-101	Open the front cover and remove the jammed paper, and then open and close the front cover.
075-102	Pull the jammed paper out of the SSF. Open and close the front cover.
075-920	Set side 2 of the sheet to the SSF.
075-922	Remove the paper from the SSF.
075-923	Pull the paper out of the SSF. Reload the paper in the SSF.
077-215	Turn off the printer. Confirm that the duplexer is correctly installed, and turn on the printer. Contact customer support if this failure is repeated.
077-300	Close the front cover.
077-301	Close the side cover.
091-912	Remove the ribbon from the drum cartridge. Contact customer support if this failure is repeated.
091-916	Open the front cover. Remove the unsupported drum cartridge, and install a supported cartridge.
091-941	Open the side cover. Remove the used yellow cartridge, and install a new cartridge.
091-942	Open the side cover. Remove the used magenta cartridge, and install a new cartridge.
091-943	Open the side cover. Remove the used cyan cartridge, and install a new cartridge.
091-944	Open the side cover. Remove the used black cartridge, and install a new cartridge.
091-972	Open the front cover, and make sure that the drum cartridge is fully installed.
092-410	Clean the CTD sensor.
092-910	
093-912	Open the side cover. Remove the used black cartridge, and install a new cartridge.

093-919	Remove and shake the yellow cartridge. Contact customer support if this failure is repeated.
093-920	Remove and shake the magenta cartridge. Contact customer support if this failure is repeated.
093-921	Remove and shake the cyan cartridge. Contact customer support if this failure is repeated.
093-922	Remove and shake the black cartridge. Contact customer support if this failure is repeated.
093-925	Turn off the printer. Confirm the black cartridge is correctly installed, and turn on the printer. Contact customer support if this failure is repeated.
093-926	Open the side cover. Remove the unsupported black cartridge, and install a supported cartridge.
093-950	Turn off the printer. Confirm the yellow cartridge is correctly installed, and turn on the printer. Contact customer support if this failure is repeated.
093-951	Turn off the printer. Confirm the magenta cartridge is correctly installed, and turn on the printer. Contact customer support if this failure is repeated.
093-952	Turn off the printer. Confirm the cyan cartridge is correctly installed, and turn on the printer. Contact customer support if this failure is repeated.
093-960	Open the side cover. Remove the unsupported yellow cartridge, and install a supported cartridge.
093-961	Open the side cover. Remove the unsupported magenta cartridge, and install a supported cartridge.
093-962	Open the side cover. Remove the unsupported cyan cartridge, and install a supported cartridge.
093-970	Open the side cover, and make sure that the yellow cartridge is fully installed.
093-971	Open the side cover, and make sure that the magenta cartridge is fully installed.
093-972	Open the side cover, and make sure that the cyan cartridge is fully installed.
093-973	Open the side cover, and make sure that the black cartridge is fully installed.
116-316	Turn off the printer. Remove the 512 MB optional memory module from the slot, and then reattach it firmly. Turn on the printer. Contact customer support if this failure is repeated.
116-317	Turn off the printer, and turn it on again. Contact customer support if this failure is repeated.
116-320	Remove the unsupported additional memory module. Contact customer support if this failure is repeated.

# Contacting Service

---

When you call for printer service, be prepared to describe the problem you are experiencing or the error message on the LCD panel.

You need to know the model type and service tag of your printer. See the label located on the rear of your printer.

# Getting Help

---

This section includes:

- ["LCD Panel Messages" on page 240](#)
- ["SimpleMonitor Alerts" on page 241](#)
- ["Obtaining the Product Information" on page 242](#)

Fuji Xerox provides several automatic diagnostic tools to help you produce and maintain print quality.

## ■ LCD Panel Messages

The LCD panel provides you with information and troubleshooting help. When an error or warning condition occurs, the LCD panel displays a message informing you of the problem.

### See also:

- ["Understanding Printer Messages" on page 235](#)

## ■ SimpleMonitor Alerts

The SimpleMonitor is a tool that is included on the *Driver CD Kit*. It automatically checks the printer status when you send a print job. If the printer is unable to print your job, the SimpleMonitor automatically displays an alert on your computer screen to let you know that the printer needs attention.

## ■ Obtaining the Product Information

### Obtaining the Latest Print Driver

The latest print driver can be obtained by downloading it from our web site.

The following procedure uses the PCL 6 driver as an example.

#### NOTE:

- The communication fee shall be borne by users.

- 1** In your print driver's **Printing Preferences** dialog box, click the **Advanced Settings** tab and then click **About**.
- 2** Click **Fuji Xerox Web Site**.  
Your web browser launches and our web site is displayed.
- 3** Follow the instructions on the web site and download an appropriate print driver.

#### NOTE:

- You can browse our web site also on the *Driver CD Kit* included with the printer. To access the web site, click **Fuji Xerox Web Site** on the startup window of the CD-ROM.
- The URL of the driver download service page is as follows: <http://www.fujixeroxprinters.com/>
- For the latest information about the print driver features, refer to the online Help provided for the print driver.

### Updating the Printer's Firmware

Our web site also provides a tool that allows you to update the printer's firmware (software embedded within the printer) from your computer.

The latest firmware and updating tool can be downloaded from the following URL.

Follow the instructions on the web site and download the correct firmware update.

<http://www.fujixeroxprinters.com/>

#### NOTE:

- The communication fee shall be borne by users.

# Non-Genuine Mode

---

When toner within a toner cartridge is empty, the `Replace XXXX Print Cartridge (XXXX: Yellow, Magenta, Cyan, or Black)` message appears.







When you want to use the printer in Non-Genuine mode, program the mode and replace the print cartridge.

## IMPORTANT:

- If you use the printer in the Non-Genuine mode, the performance of the printer may not be at its optimum. And any problems that may arise from the use of the Non-Genuine mode are not covered by our quality guarantee. The continuous use of the Non-Genuine mode can also cause the printer to break down, and any repair charges for such break down will be incurred by users.

## NOTE:

- Before starting the operation described below, confirm that `Ready` is displayed on the LCD panel.

- 1 Press the **Menu** button.
- 2 Select `Admin Menu`, and then press the  button.
- 3 Select `Maintenance Mode`, and then press the  button.
- 4 Select `Non-Genuine`, and then press the  button.
- 5 Select `Toner`, and then press the  button.
- 6 Select `On`, and then press the  button.
- 7 Press the  button twice.

The printer switches to the Non-Genuine mode.





# Maintenance

This chapter includes:

- ["Cleaning the Printer" on page 246](#)
- ["Replacing Toner Cartridges" on page 252](#)
- ["Replacing the Drum Cartridge" on page 257](#)
- ["Replacing the Fuser Unit" on page 263](#)
- ["Replacing the Feed Roller Unit" on page 269](#)
- ["Ordering Supplies" on page 272](#)
- ["Storing Print Media" on page 276](#)
- ["Storing Consumables" on page 277](#)
- ["Managing the Printer" on page 278](#)
- ["Conserving Supplies" on page 281](#)
- ["Checking Page Counts" on page 282](#)
- ["Moving the Printer" on page 283](#)

# Cleaning the Printer

---

This section describes how to clean the printer in order to maintain it in good condition and print clean printouts all the time.

 **WARNING:**

- **When cleaning this product, use the designated cleaning materials exclusive to it. Other cleaning materials may result in poor performance of the product. Never use aerosol cleaners, or it may catch fire and cause explosion.**

 **CAUTION:**

- **When cleaning this product, always switch off and unplug it. Access to a live machine interior may cause electric shock.**

This section includes:

- ["Cleaning Inside the Printer" on page 247](#)
- ["Cleaning the Color Toner Density \(CTD\) Sensor" on page 250](#)

## ■ Cleaning Inside the Printer

Clean the feed roller inside the printer if print media does not feed correctly.

- 1 Turn off the printer and disconnect the power cord.
- 2 Pull the standard 250-sheet tray out of the printer about 200 mm. Hold the standard 250-sheet tray with both hands, and remove it from the printer.

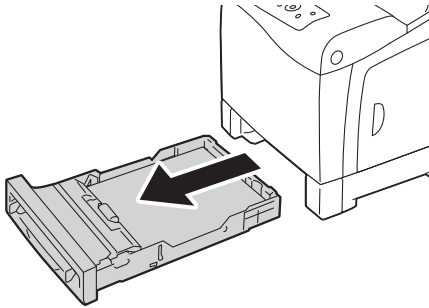

- 3 Push the side button to open the front cover.



- 4 Open the belt unit.

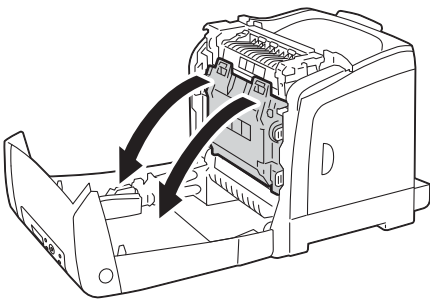

- 5 Turn the four drum cartridge lock levers 90-degrees counterclockwise.

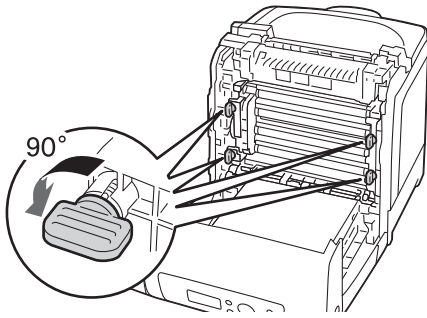

- 6** Hold the drum cartridge levers, and then pull out the drum cartridge.

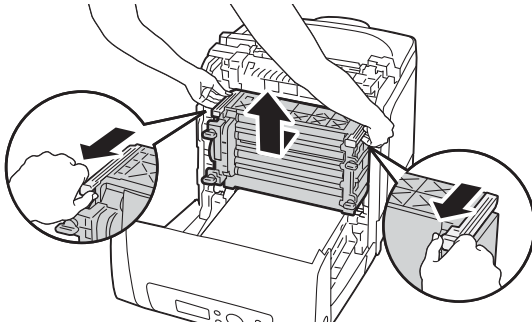

**NOTE:**

- Keep the drum cartridge in a dark place. If the front cover remains open for more than 3 minutes, print quality may deteriorate.

- 7** Clean the feed roller inside the printer with a dry cloth.

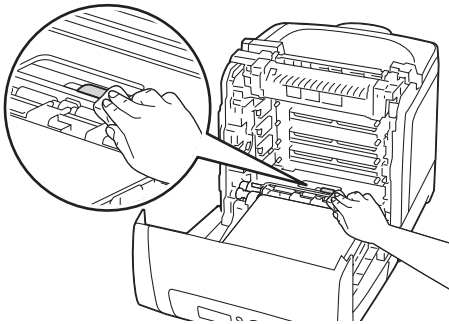

- 8** Insert the drum cartridge until the line on the handle aligns with the white line on the printer.

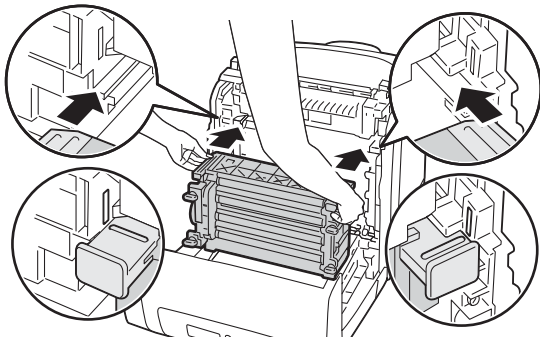

- 9** Turn the four drum cartridge lock levers 90-degrees clockwise to lock the drum cartridge.

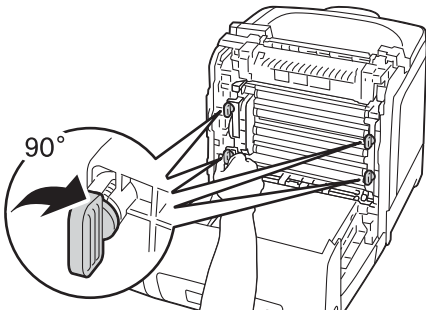

**10** Close the belt unit, and push at the top of the unit until it clicks.

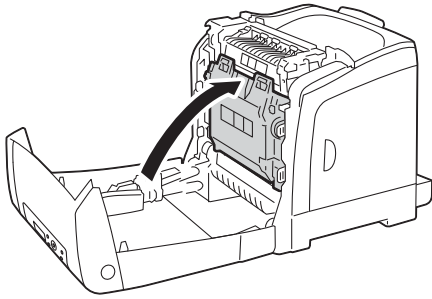

**11** Close the front cover.

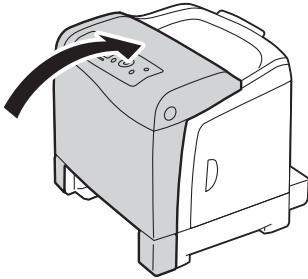

**12** Insert the standard 250-sheet tray into the printer, and push until it stops.

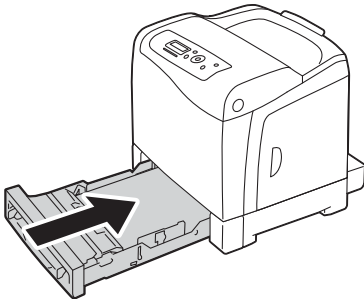

**IMPORTANT:**

- Do not use excessive force on the tray. Doing so could damage the tray or the inside of the printer.

## ■ Cleaning the Color Toner Density (CTD) Sensor

Clean the Color Toner Density (CTD) sensor only when an alert for the CTD sensor is shown on the Printer Status window or operator panel.

- 1 Turn off the printer and disconnect the power cord.
- 2 Pull the standard 250-sheet tray out of the printer about 200 mm. Hold the standard 250-sheet tray with both hands, and remove it from the printer.

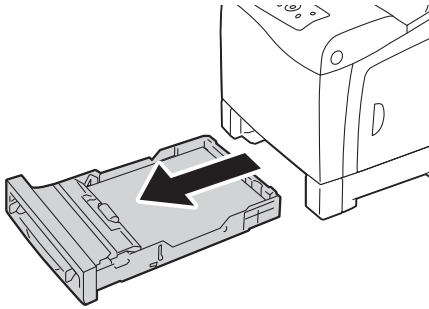

- 3 Push the side button to open the front cover.

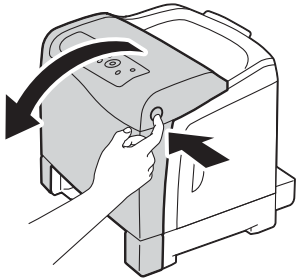

- 4 Open the belt unit.

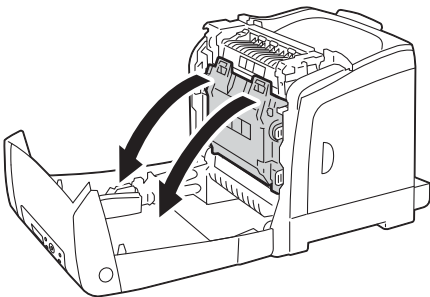

- 5 Clean the CTD sensor inside the printer with a clean dry cotton swab.

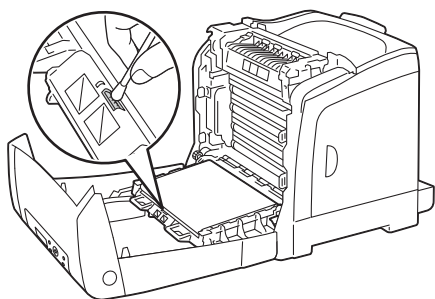

**6** Close the belt unit, and push at the top of the unit until it clicks.

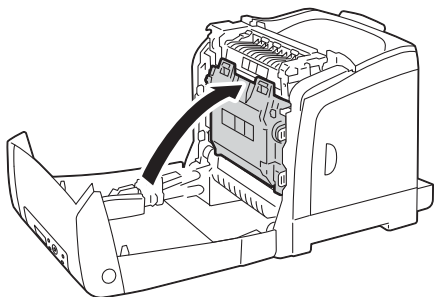

**7** Close the front cover.

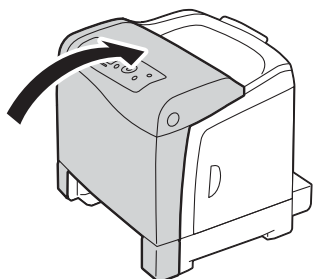

**8** Insert the standard 250-sheet tray into the printer, and push until it stops.

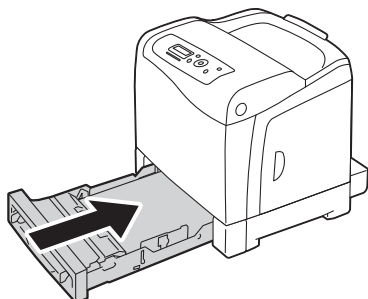

**IMPORTANT:**

- Do not use excessive force on the tray. Doing so could damage the tray or the inside of the printer.



# Replacing Toner Cartridges

---

Fuji Xerox toner cartridges are available only through Fuji Xerox.

It is recommended that you use Fuji Xerox toner cartridges for your printer. Fuji Xerox does not provide warranty coverage for problems caused by using accessories, parts, or components not supplied by Fuji Xerox.

## **WARNING:**

- **Use a broom or a wet cloth to wipe off spilled toner. Never use a vacuum cleaner for the spills. It may catch fire by electric sparks inside the vacuum cleaner and cause explosion. If you spill a large volume of toner, contact your local Fuji Xerox representative.**
- **Never throw a toner cartridge into an open flame. Remaining toner in the cartridge may catch fire and cause burn injuries or explosion. If you have a used toner cartridge no longer needed, contact your local Fuji Xerox representative for its disposal.**

## **CAUTION:**

- **Keep toner cartridges out of the reach of children. If a child accidentally swallows toner, spit it out, rinse mouth with water, drink water and consult a physician immediately.**
- **When replacing toner cartridges, be careful not to spill the toner. In case of any toner spills, avoid contact with clothes, skin, eyes and mouth as well as inhalation.**
- **If toner spills onto your skin or clothing, wash it off with soap and water. If you get toner particles in your eyes, wash it out with plenty of water for at least 15 minutes until irritation is gone. Consult a physician if necessary. If you inhale toner particles, move to a fresh air location and rinse your mouth with water. If you swallow toner, spit it out, rinse your mouth with water, drink plenty of water and consult a physician immediately.**

## **IMPORTANT:**

- Do not shake the used toner cartridge to avoid spilling of the toner.
- Be sure to use the starter toner cartridge shipped with the printer until it gets empty, and then replace it with a purchased one.
- Replace the toner cartridge with the printer turned on. If you turn off the printer, print data remaining in the printer, and information stored on the printer's memory are erased.

This section includes:

- ["Overview" on page 253](#)
- ["Removing the Toner Cartridges" on page 254](#)
- ["Installing a Toner Cartridge" on page 255](#)

## ■ Overview

The printer has toner cartridges of four colors: black (K), yellow (Y), magenta (M), and cyan (C).

When a toner cartridge reaches its usable life-span, the following messages appear on the LCD panel.

Message	Action
Replace XXXX Toner Cartridge Soon	The toner cartridge has become empty. Replace the old toner cartridge with a new one.

### IMPORTANT:

- When placing a used toner cartridge on the floor or on a table, place a few sheets of paper under the toner cartridge to catch any toner that may spill.
- Do not reuse old toner cartridges once you remove them from the printer. Doing so can impair print quality.
- Do not shake or pound the used toner cartridges. The remaining toner may spill.
- We recommend you to use up the toner cartridges within one year after removing them from the packaging.

## ■ Removing the Toner Cartridges

- 1 Open the side cover.

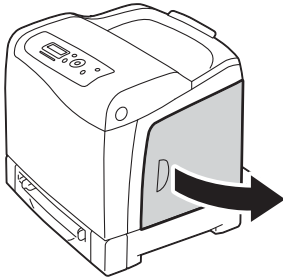

- 2 Push the latch(es) backwards to pop open the toner cartridge(s) that you want to replace.

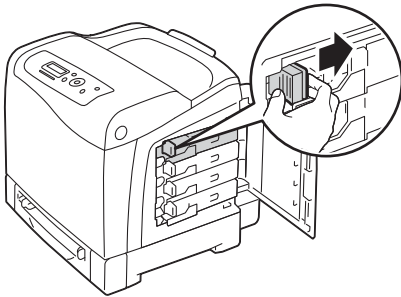

- 3 Pull the cartridge holder until it clicks, and then pull out the toner cartridge.

### **IMPORTANT:**

- Always pull the toner cartridge out slowly so you do not spill any toner.

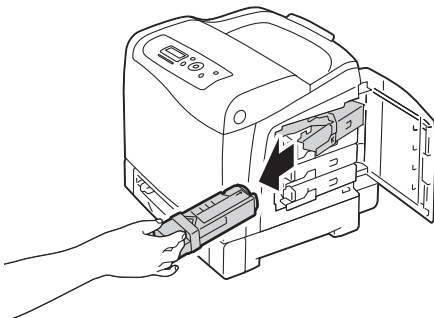

## ■ Installing a Toner Cartridge

- 1 Unpack a new toner cartridge of the desired color and shake it five to six times to distribute the toner evenly.

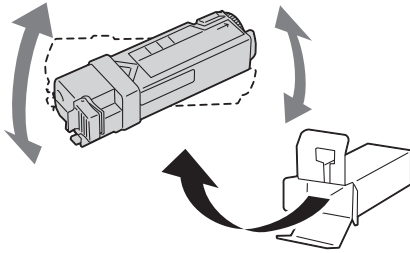

### NOTE:

- Ensure that the color of the new toner cartridge matches that on the handle before replacing it.
- Handle the toner cartridge carefully to avoid spilling of the toner.

- 2 Insert the toner cartridge into the associated cartridge holder, and then slide the latch of the toner cartridge.

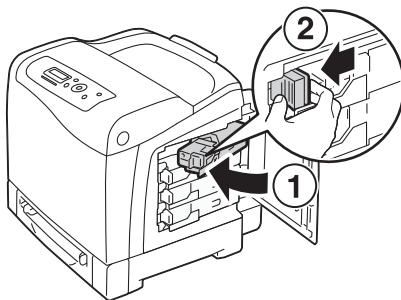
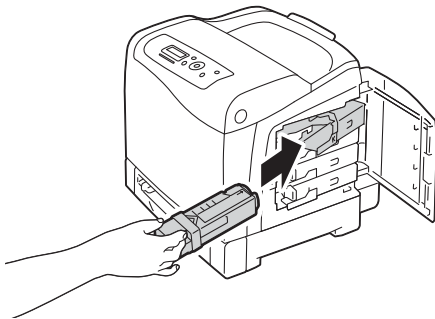

- 3 Close the side cover.

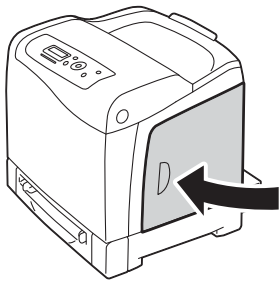

# Replacing the Drum Cartridge

---

This section describes how to replace the drum cartridge.

## **IMPORTANT:**

- Protect the drums of the drum cartridge against bright light. If the front cover remains open for more than 3 minutes, print quality may deteriorate.
- Ensure nothing touches or scratches the surface (black-colored film) of the belt unit. Scratches, dirt, or oil from your hands on the film of the belt unit may reduce print quality.
- Replace the drum cartridge with the printer turned on. If you turn off the printer, print data remaining in the printer, and information stored on the printer's memory are erased.

This section includes:

- ["Removing the Drum Cartridge" on page 258](#)
- ["Installing the Drum Cartridge" on page 260](#)

## ■ Removing the Drum Cartridge

- 1 Pull the standard 250-sheet tray out of the printer about 200 mm. Hold the standard 250-sheet tray with both hands, and remove it from the printer.

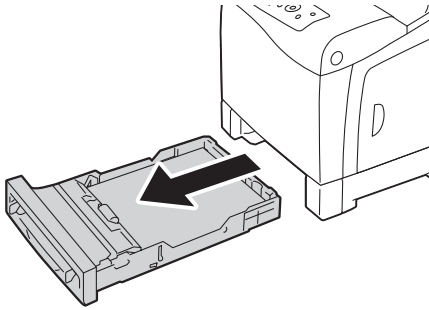

- 2 Push the side button to open the front cover.

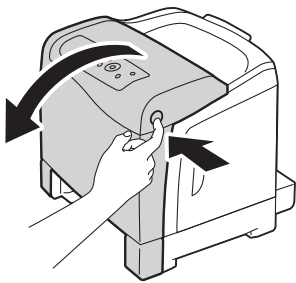

- 3 Open the belt unit.

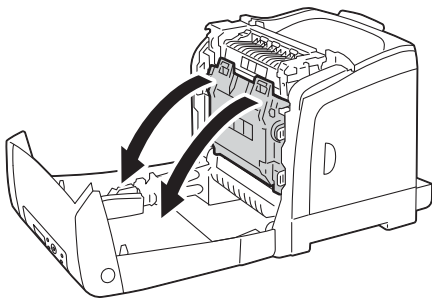

- 4 Turn the four drum cartridge lock levers 90-degrees counterclockwise.

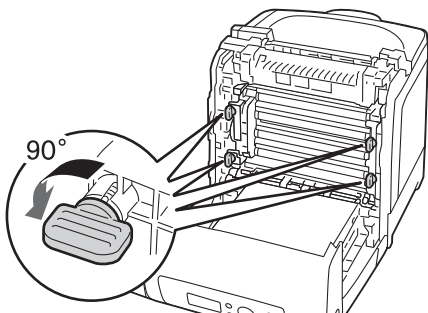

- 5 Hold the drum cartridge levers, and then pull out the drum cartridge.

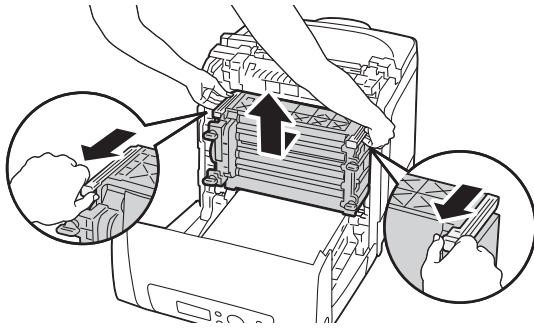



## ■ Installing the Drum Cartridge

- 1 Open the drum cartridge packaging.

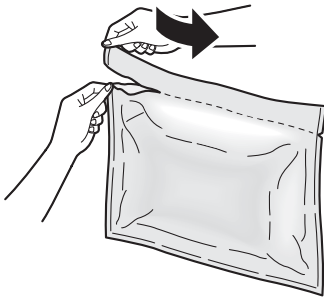

- 2 Take out the drum cartridge from the packaging.

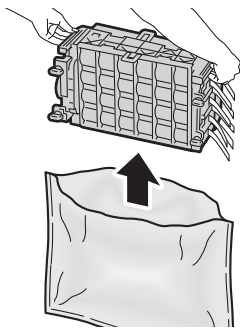

- 3 Completely pull out the eight yellow ribbons from the drum cartridge.

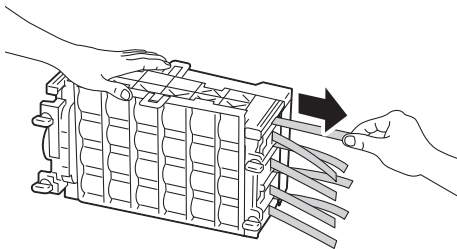

- 4 Remove the rear protective cover from the drum cartridge.

### NOTE:

- Do not remove the front protective cover at this moment.

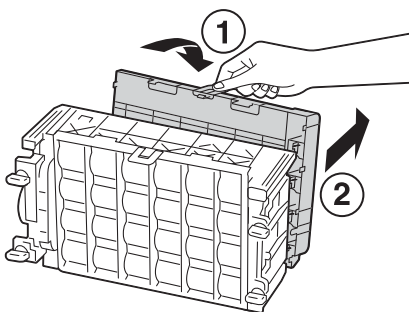

5 Insert the drum cartridge until the line on the handle aligns with the white line on the printer.

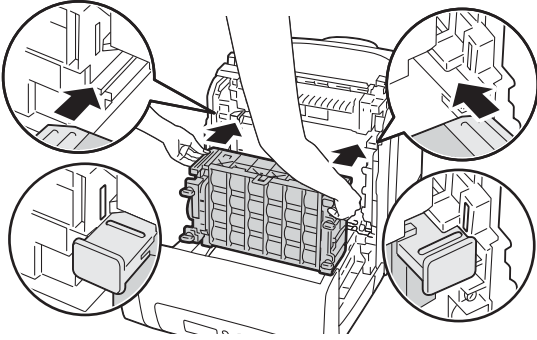

6 Turn the four drum cartridge lock levers 90-degrees clockwise to lock the drum cartridge.

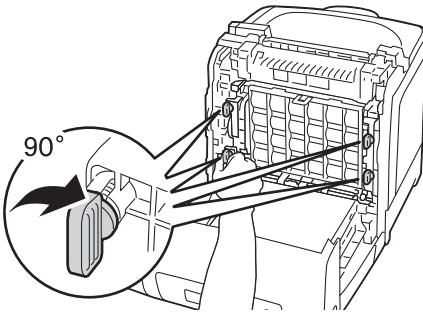

7 Remove the front protective cover from the drum cartridge.

**IMPORTANT:**

- Ensure that you do not hit the belt unit when removing the front protective cover.

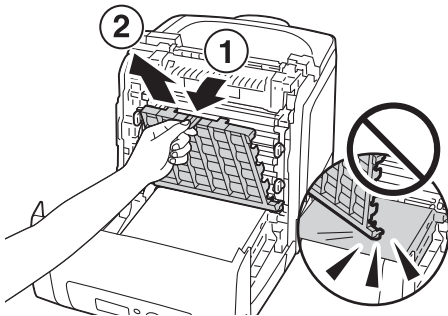

8 Close the belt unit, and push at the top of the unit until it clicks.

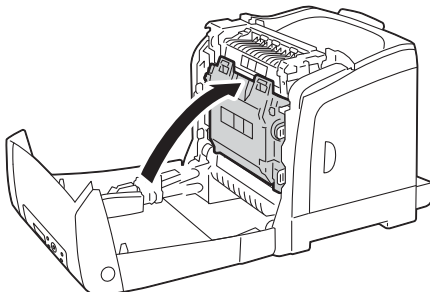

9 Close the front cover.

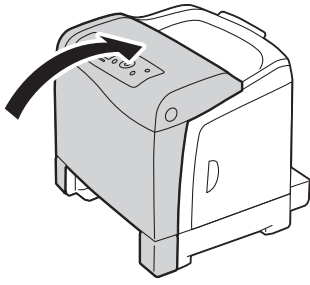

- 10** Insert the standard 250-sheet tray into the printer, and push until it stops.

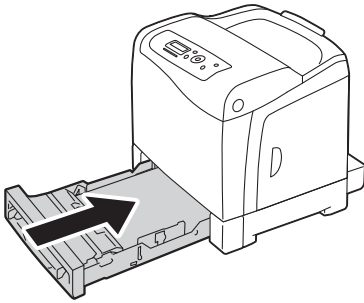

**IMPORTANT:**

- Do not use excessive force on the tray. Doing so could damage the tray or the inside of the printer.

# Replacing the Fuser Unit

---

This section describes how to replace the fuser unit.

 **CAUTION:**

- Before removing the fuser unit, turn off the printer and wait for 40 minutes until the fuser unit cools down.

**IMPORTANT:**

- To prevent electric shock, always turn off the printer and disconnect the power cord from the grounded outlet before performing maintenance.
- Avoid bright light and try to finish the replacement within 3 minutes.

This section includes:

- ["Removing the Fuser Unit" on page 264](#)
- ["Installing the Fuser Unit" on page 266](#)
- ["Resetting the Counter of the Fuser Unit" on page 268](#)

## ■ Removing the Fuser Unit

- 1 Turn off the printer and disconnect the power cord.
- 2 Remove any paper in the output tray.

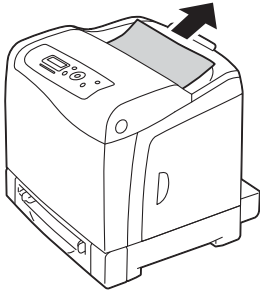

- 3 Push the side button to open the front cover.

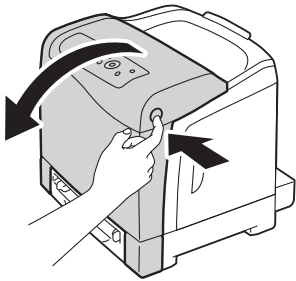

- 4 Open the belt unit.

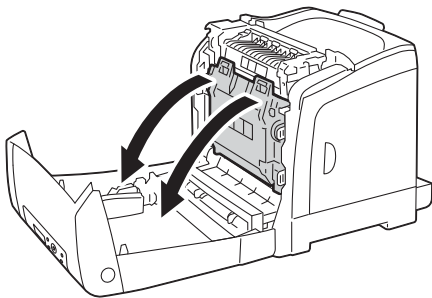

- 5 Pinch the gray lever on the right side of the fuser unit and lower the lever toward you.

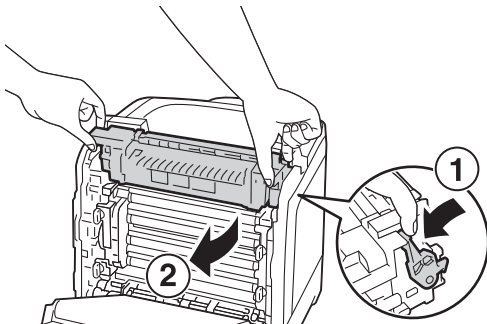

- 6** Hold both sides of the fuser unit. Next, slightly raise the right side while holding down the left side, and slide out the fuser unit.

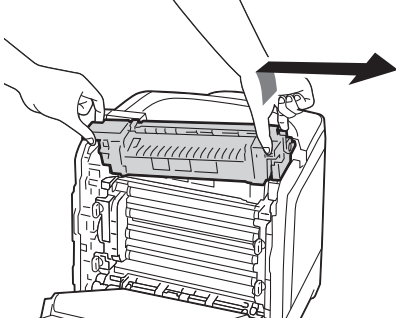

## ■ Installing the Fuser Unit

- 1 Insert the protrusions of the new fuser unit into the two slots of the printer.

### NOTE:

- Hold both sides of the fuser unit with your hands.
- Make sure that the fuser unit is firmly set in the slots and cannot be moved easily.

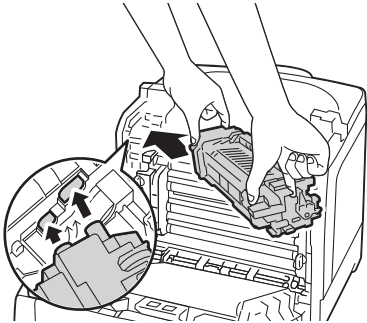

- 2 Push the fuser unit forward until the right groove of the snaps into place.

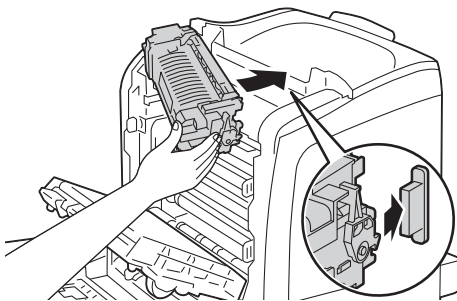

- 3 Close the belt unit, and push at the top of the unit until it clicks.

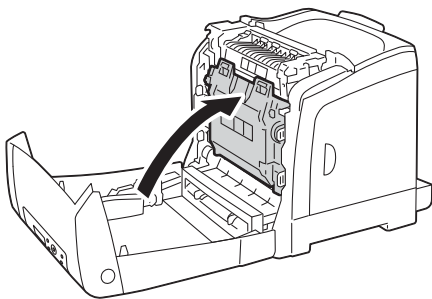

- 4 Close the front cover.

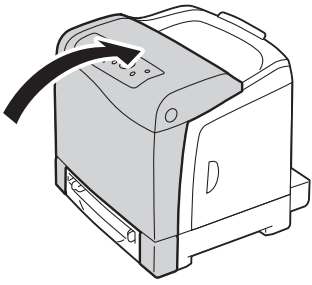





- 5 Reconnect the power cord to the power connector and turn on the printer.



## ■ Resetting the Counter of the Fuser Unit

After replacing the fuser unit, use the operator panel to reset the counter of the fuser unit.

- 1 Press the **Menu** button.
- 2 Select `Admin Menu`, and then press the  button.
- 3 Select `Maintenance Mode`, and then press the  button.
- 4 Select `Reset Fuser`, and then press the  button.
- 5 Ensure that `Are You Sure?` appears, and then press the  button.

# Replacing the Feed Roller Unit

---

This section describes how to replace the feed roller unit in the standard 250-sheet tray. Regularly replacing the feed roller helps ensure the best quality output.

Fuji Xerox feed rollers are available only through Fuji Xerox. To order by phone, see also "[Online Services](#)" on page 293.

It is recommended that you use Fuji Xerox feed rollers for your printer. Fuji Xerox does not provide warranty coverage for problems caused by using accessories, parts, or components not supplied by Fuji Xerox.

This section includes:

- "[Removing the Feed Roller Unit in the Standard 250-Sheet Tray](#)" on page 270
- "[Installing the Feed Roller Unit in the Standard 250-Sheet Tray](#)" on page 271

## ■ Removing the Feed Roller Unit in the Standard 250-Sheet Tray

- 1 Pull the standard 250-sheet tray out of the printer about 200 mm. Hold the standard 250-sheet tray with both hands, and remove it from the printer.

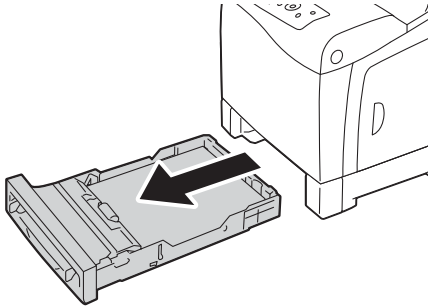

### NOTE:

- Ensure that you remove all the paper from the standard 250-sheet tray before removing the feed roller unit.

- 2 Holding the feed roller tabs with your fingers, pull the feed roller unit out of the groove in the axle.

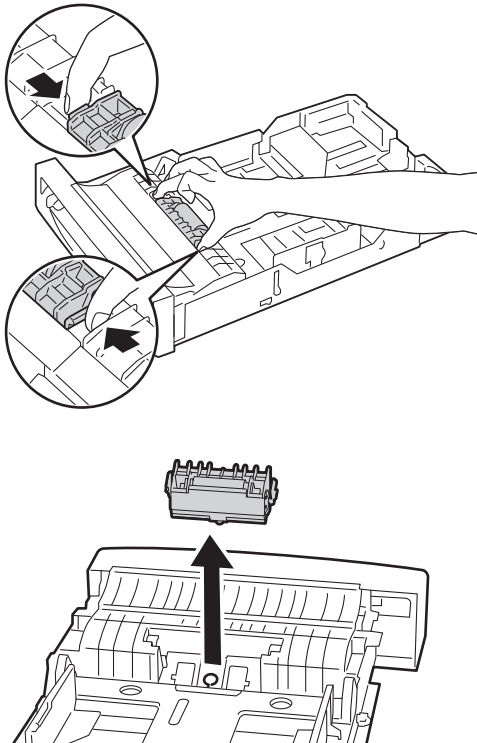

## ■ Installing the Feed Roller Unit in the Standard 250-Sheet Tray

- 1 Align the new feed roller unit with the groove on the axle.

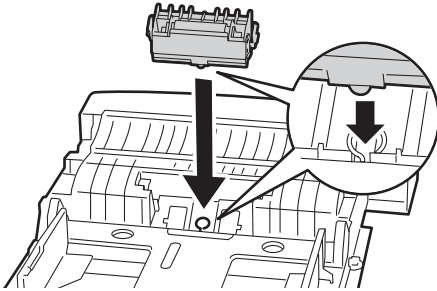

- 2 Insert the feed roller unit into the axle until it snaps. The protrusions fit completely into the slots and the roller hook reseats into the groove on the axle.

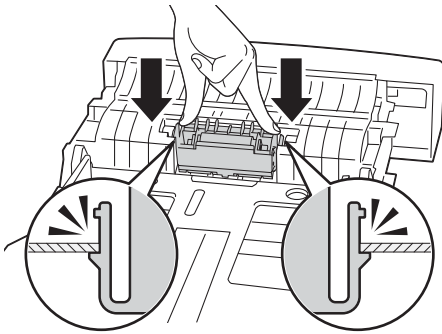

- 3 Load paper in the standard 250-sheet tray, and then insert the standard 250-sheet tray into the printer and push until it stops.

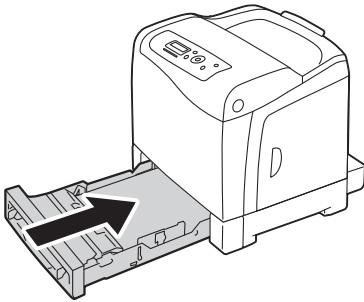

### **IMPORTANT:**

- Do not use excessive force on the tray. Doing so could damage the tray or the inside of the printer.

# Ordering Supplies

---

This section includes:

- ["Consumables" on page 273](#)
- ["When to Order Supplies" on page 274](#)
- ["Recycling Supplies" on page 275](#)

Certain consumables and routine maintenance items need to be ordered occasionally. Each supply includes installation instructions on the box.

## ■ Consumables

### IMPORTANT:

- Use of consumables/periodical replacement parts not recommended by Fuji Xerox can impair machine quality and performance. Use only consumables/periodical replacement parts recommended by Fuji Xerox.

Product Name	Product Code	Printable number of pages
Toner Cartridge K	CT201632	Approx. 3000 pages
Toner Cartridge C	CT201633	Approx. 3000 pages
Toner Cartridge M	CT201634	Approx. 3000 pages
Toner Cartridge Y	CT201635	Approx. 3000 pages
Drum Cartridge	CT350876	Approx. 20000 pages
Fuser Unit-220V	EL300822	Approx. 50000 pages
Fuser Unit-110V	EL300823	Approx. 50000 pages
Feed Roller Unit	EL300775	Approx. 50000 pages

- The number of printable pages are applicable when A4 plain paper SEF (☐) is used and printing is done continuously at a density such that each toner covers 5% of the page. These values are estimates and vary depending on conditions such as the content being printed, paper size, paper type, the printer's operating environment, initializing process done when you turn on or off the printer, and adjustments to maintain print quality.

### NOTE:

- Each toner cartridge includes installation instructions on the box.

## ■ When to Order Supplies

The LCD panel displays a warning when the supply nears its replacement time. Verify that you have replacements on hand. It is important to order these supplies when the messages first appear to avoid interruptions to your printing. The LCD panel displays an error message when the supply must be replaced.

To order supplies, contact the Fuji Xerox local representative office or an authorised dealer.

### **IMPORTANT:**

- This printer is designed to provide the most stable performance and print quality when used with the recommended consumables. Not using consumables recommended for this machine degrades the performance and printing quality of the printer. You could also incur charges if the machine breaks down. To receive customer support and achieve the optimum performance of the printer, be sure to use recommended consumables.

## ■ Recycling Supplies

- For environmental protection and efficient use of resources, Fuji Xerox reuses returned toner cartridges to make recycle parts, recycle materials or energy recovery.
- Proper disposal is required for toner cartridges no longer needed. Do not open toner cartridges containers. Return them to your local Fuji Xerox representative.
- To recover scarce resources, rechargeable batteries used in the returned machines are recycled as materials or reused for energy generation.



# Storing Print Media

---

To avoid potential paper feeding problems and uneven print quality, there are several things you can do:

- To achieve the best possible print quality, store print media in an environment where the temperature is approximately 70 °F/21 °C and the relative humidity is 40%.
- Store cartons of print media on a pallet or shelf, rather than directly on the floor.
- If you store individual packages of print media out of the original carton, ensure that they rest on a flat surface so the edges do not buckle or curl.
- Do not place anything on top of the print media packages.

# Storing Consumables

---

Store consumables in their original packaging until you need to use them. Do not store consumables in:

- Temperatures greater than 104 °F/40 °C.
- An environment with extreme changes in humidity or temperature.
- Direct sunlight.
- Dusty places.
- A car for a long period of time.
- An environment where corrosive gases are present.
- A humid environment.

# Managing the Printer

---

This section includes:

- ["Checking or Managing the Printer with CentreWare Internet Services"](#) on page 279
- ["Checking Printer Status with SimpleMonitor \(Windows Only\)"](#) on page 280

## ■ Checking or Managing the Printer with CentreWare Internet Services

When the printer is installed in a TCP/IP environment, you can use CentreWare Internet Services to check the printer status, the remaining volume of consumables, and the paper loaded in this printer. You can also use CentreWare Internet Services to configure printer settings.

### NOTE:

- When using the printer as a local printer, you cannot use CentreWare Internet Services. For details about checking the status of a local printer, refer to "[Checking Printer Status with SimpleMonitor \(Windows Only\)](#)" on [page 280](#).

## Starting CentreWare Internet Services

Use the following procedure to start CentreWare Internet Services.

- 1 Launch your web browser.
- 2 Enter the IP address in the browser's **Address** field, and then press the **Enter** key.  
The CentreWare Internet Services screen appears.

### • Using Online Help

For details regarding the items that can be set in each CentreWare Internet Services screen, click the **Help** button to display the online Help.

## ■ Checking Printer Status with SimpleMonitor (Windows Only)

SimpleMonitor is a tool that is installed with your Fuji Xerox print driver. It automatically checks the printer status when you send a print job. SimpleMonitor can check the paper size loaded into the tray, the status of the output tray, and the remaining amount of consumables, such as toner cartridges.

### Starting SimpleMonitor

Double-click the SimpleMonitor icon on the taskbar or right-click the icon and select **Select Printer**.

If the SimpleMonitor icon is not displayed on the taskbar, open SimpleMonitor from the **Start** menu:

The following procedure uses Microsoft® Windows® XP as an example.

- 1 Click **start** → **All Programs** → **Fuji Xerox** → **SimpleMonitor for Asia-Pacific** → **Activate SimpleMonitor**.

The **Select Printer** window appears.

- 2 Click the name of the desired printer from the list.

- 3 The Printer Status window appears.

For details about the functions of SimpleMonitor, refer to the online Help.

# Conserving Supplies

---

You can change several settings in your print driver to conserve toner cartridge and paper.

The following descriptions use the PCL 6 driver as an example.

Supply	Setting	Function
Toner cartridge	<b>Draft Mode</b> in the <b>Advanced Settings</b> tab	This check box allows the users to select a print mode that uses less toner. The image quality will be lower when this feature is used.
Print media	<b>Multiple-Up</b> in the <b>Layout</b> tab	The printer prints two or more pages on one side of a sheet. Values for <b>Multiple-Up</b> are 2 Pages Up, 4 Pages Up, 8 Pages Up, 16 Pages Up, 32 Pages Up. Combined with the duplex setting, <b>Multiple-Up</b> allows you to print up to 64 pages on one sheet of paper. (32 images on the front and 32 on the back)

# Checking Page Counts

---

The total number of printed pages can be checked at the operator panel. Four meters are available: Meter 1, Meter 2, Meter 3, and Meter 4.

The Meter Readings counts the number of pages printed properly. Single side color print (including N-up) is counted as one job, and 2-sided print (including N-up) is counted as two. During 2-sided printing, if an error occurs after one side is printed properly, it is counted as one.

When printing color data, which has been converted by using ICC profile on an application, with the Color (Auto) setting, the data is printed by color even if it seems to be black and white data on the monitor. In that case, Meter 1 and Meter 4 are increased.

When doing 2-sided printing, a blank page may be inserted automatically depending on the settings of the application. In this case, the blank page is counted as one page.

For information about the individual meter, see ["Meter Readings" on page 145](#).

Use the following procedure to check a meter:

- 1 Press the **Menu** button.
- 2 Select Meter Readings, and then press the  button.
- 3 Select the desired meter to check the number of pages.

# Moving the Printer

---

This section describes how to move the printer.

## IMPORTANT:

- Two people are required to move the printer.
- To prevent you from dropping the printer and getting backache or injuries, lift the printer by firmly gripping the recessed areas on both sides of the printer. Never lift the printer by gripping any other areas.

## NOTE:

- If the optional 250-sheet feeder has been installed, uninstall the optional 250-sheet feeder before moving the printer. If the optional 250-sheet feeder is not fixed securely to the printer, it may fall to the ground and cause injuries. For details on how to uninstall the optional 250-sheet feeder, see ["Removing the Optional 250-Sheet Feeder" on page 288](#).

- 1 Turn off the printer and disconnect the power cord, interface cable, and any other cables.
- 2 Remove any paper in the output tray and slide the output tray extension inside the printer.

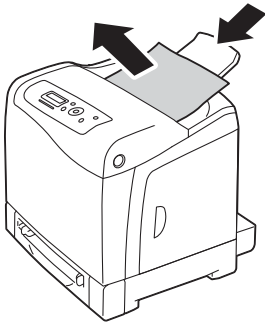

- 3 Pull the standard 250-sheet tray out of the printer about 200 mm. Hold the standard 250-sheet tray with both hands, and remove it from the printer.

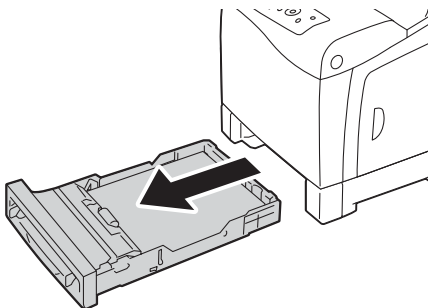

- 4 Lift the printer and move it gently.

## NOTE:

- If you move the printer over a long distance, remove the toner cartridges from the printer to prevent toner from spilling, and pack the printer inside a box.



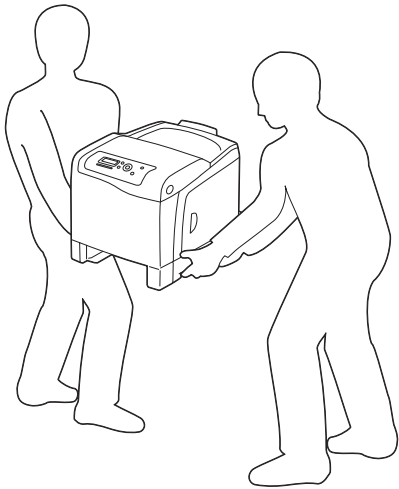

- 5** Insert the standard 250-sheet tray into the printer, and push until it stops.

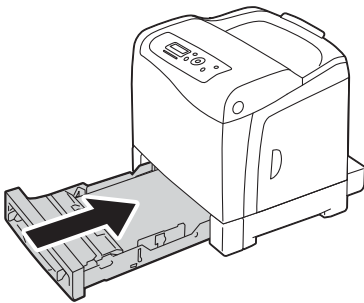

**IMPORTANT:**

- Do not use excessive force on the tray. Doing so could damage the tray or the inside of the printer.

- 6** Adjust the color registration before using your printer.

**See also:**

- ["Adjusting Color Registration" on page 227](#)

# Removing Options

---

If the printer location needs to be changed or the printer and print media handling options need to be shipped to a new location, all print media handling options must be removed from the printer. For shipping, pack the printer and print media handling options securely to avoid damage.

This section includes:

- ["Removing the Optional Memory Module" on page 286](#)
- ["Removing the Optional 250-Sheet Feeder" on page 288](#)

## ■ Removing the Optional Memory Module

- 1 Turn off the printer.

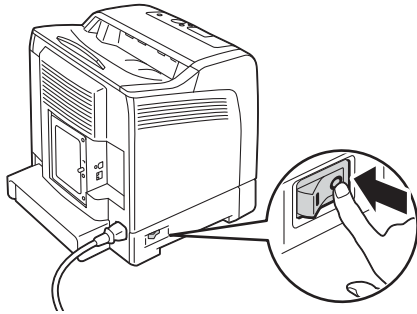

- 2 Turn the screw on the control board cover counterclockwise, and open the cover.

### NOTE:

- Loosen the screw. You do not need to remove the screw.

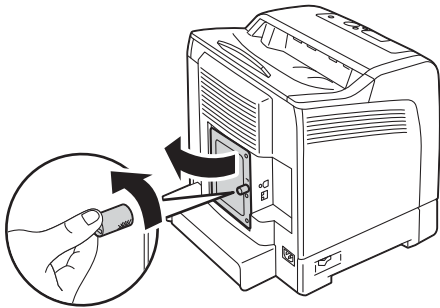

- 3 Push the clips on both sides of the slot outward.

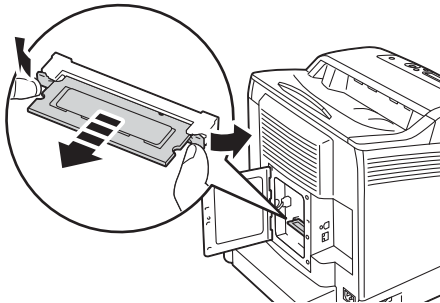

- 4 Hold the memory module and pull it straight out.

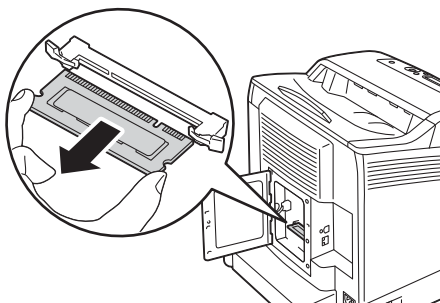

- 5 Close the control board cover, and turn the screw clockwise.

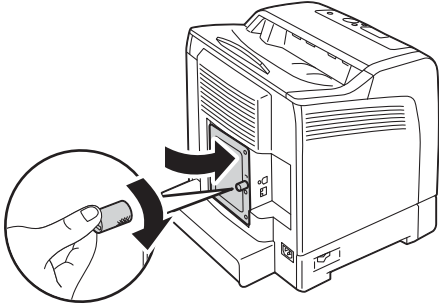

- 6 Turn on the printer.

## ■ Removing the Optional 250-Sheet Feeder

- 1 Turn off the printer.

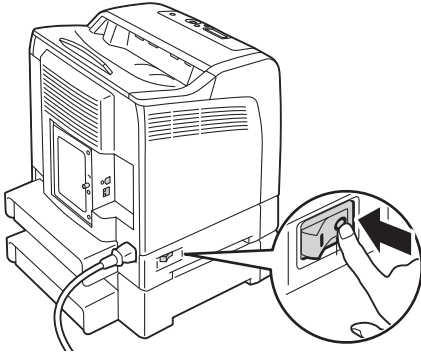

- 2 Disconnect the power cord from the power connector on the rear of the printer.

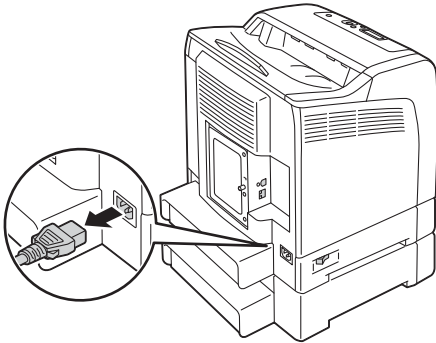

- 3 Pull the standard 250-sheet tray out of the printer about 200 mm. Hold the standard 250-sheet tray with both hands, and remove it from the printer.

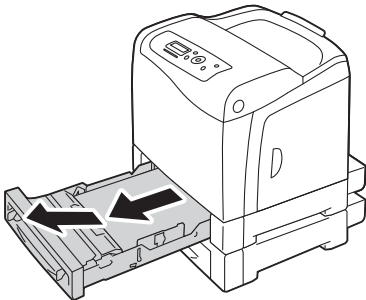

- 4 Remove the two screws joining the printer and the optional 250-sheet feeder by unscrewing them with a coin or similar object.

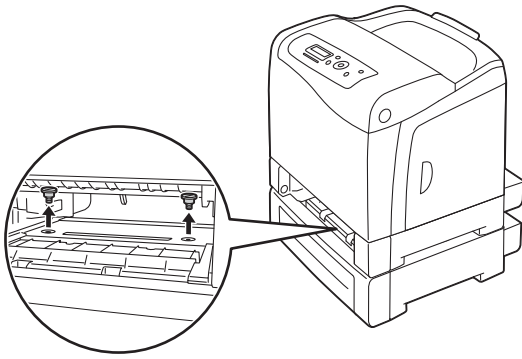

5 Gently lift the printer off the optional 250-sheet feeder, and place it on a level surface.

**⚠ CAUTION:**

- Two people are required to lift the printer.

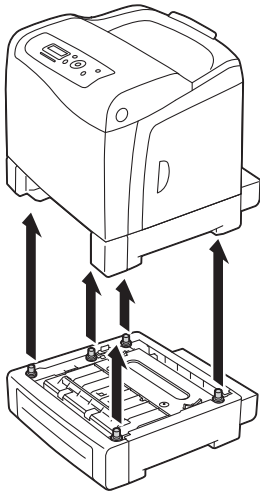

6 Insert the standard 250-sheet tray into the printer, and push until it stops.

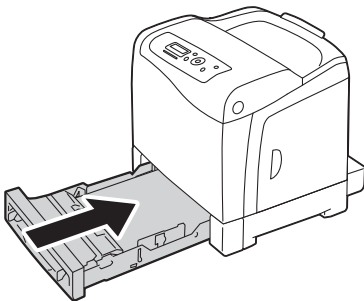

7 Reconnect all cables into the rear of the printer and turn on the printer.



# Contacting Fuji Xerox

This chapter includes:

- ["Technical Support" on page 292](#)
- ["Online Services" on page 293](#)



# Technical Support

---

Fuji Xerox recommends the Customer first utilize support materials shipped with the product, product diagnostics, information contained on the Web, and email support. If unsuccessful, to obtain service under product warranty the Customer must notify Fuji Xerox Telephone Support or its authorized service representative of the defect before the expiration of the warranty period. Customer will provide appropriate assistance to Telephone Support personnel to resolve issues, such as restoration of the operating system, software program and drivers to their default configuration and settings, verification of functionality of Fuji Xerox supplied products, replacement of customer replaceable units, clearing paper misfeeds and cleaning the unit and other prescribed routine and preventative maintenance.

If the Customer's product contains features that enable Fuji Xerox or its authorised service representative to diagnose and repair problems with the product remotely, Fuji Xerox may request that the Customer allow such remote access to the product.

# Online Services

---

You can find detail Product and Consumable warranty information and activate your warranty by registering your details on our website at <http://www.fujixerox.com/support/docuprint/>

Fuji Xerox Online Support Assistant provides instructions and troubleshooting guides to resolve your printer problems. It is an easy-to-use, searchable online help. To find out more, please visit our online support at <http://www.fujixerox.com/support/docuprint/>



# Index

## Numerics

- 2 Sided Print 125
- 2 Sided, Flip on Short Edge 125
- 2-Sided 148
- 2-Sided Print 152

## A

- Adjust Altitude 167
- Adjust BTR 164
- Adjust ColorRegi 165
- Adjust Fuser 164
- Adjust PaperType 163
- Adjusting Color Registration 227
- Admin Menu 146
- Adobe Protocol 157
- Assigning an IP Address 67
- Audio Tones 159
- Auditron 134
- Auditron Mode 162
- Auto Adjust Regi 165
- Auto Job History 160
- Auto Reset 158
- Automatic Duplex Printing 124
- Automatically Setting the IP Address 65
- Avoiding jam 181

## B

- Back button 35
- Banner Sheet 161
- Basic Printer Problems 199
- Belt Unit 33
- Bonjour (mDNS) 156
- Booklet Print 125
- BOOTP 155

## C

- Cancel Job button 35
- Canceling a print job 119
- Canceling print job
  - From Operator panel 119
  - From your computer 119
- CentreWare Internet Services 53
  - managing printer 279
  - online help for 279
  - starting 279
- Checking Page Counts 282
- checking printed pages

- how to check the meter 282
- Checking Status of Print Data 135
- Clean Developer 166
- Cleaning Inside the Printer 247
- Cleaning the CTD Sensor 250
- Clear Storage 167
- Clearing jam 180
- Clearing Paper Jam
  - From Duplexer 191
  - From Fuser Unit 189
  - From Optional 250-sheet Feeder 192
  - From SSF 183
  - From Standard 250-sheet Tray 186
- Clock Settings 159
- Collated 152
- Color registration chart 229
- Connecting local printer 61
- Connecting printer 59
- Connection specification 59
- Connection type 59
- Conserving supplies 281
  - consumables 273
- Contacting Fuji Xerox 291
- Contacting service 238
- ContentsBridge Utility 122
- Control Board Cover 34
- Counter of the Fuser Unit 268
- CTD Sensor 250

## D

- DefaultPaperSize 160
- Demo Page 144
- Determining Values 230
- DHCP 155
- DHCP / AutoIP 155
- Disabling the Panel Lock 175
- Display Problems 200
- Draft Mode 151
- Drum Cartridge 33
- Drum Refresh 166
- Dual Stack 154
- Duplex Printing 124
- Duplexer 33, 182
- Dynamic Methods of Setting the IP Address 66

## E

- electrical safety 15
- Enabling the Panel Lock 174
- Energy Saver button 35

Entering Values 231  
Envelope 164  
Error History 143  
Error LED 35  
Error-Code 235  
Ethernet 154  
Ethernet Port 34, 59

## F

F/W Version 163  
Fast Scan 230  
Fault Time-out 158  
Font 148  
Font Pitch 150  
Font Size 149  
Form Line 150  
Front Cover 33, 182  
FTP 155  
Fuser Unit 33, 182

## G

Gateway Address 155  
Get IP Address 155  
getting help 239  
    SimpleMonitor Alerts 241

## H

Heavy Card 164  
Hex Dump 150  
how to check the meter 282  
How to install option 38  
How to remove option 285  
How to replace feed roller unit 269  
HW Gloss Card 164, 165

## I

IEEE 802.1x 156  
Image Enhance 150  
Init Print Meter 166  
Initialize NVM 156, 166  
Installing a Toner Cartridge 255  
Installing Optional Accessories 38  
Installing Print Driver  
    print driver (Linux) 82  
    print driver (Macintosh) 81  
    print driver (Windows) 71  
Installing the Drum Cartridge 260  
Installing the Feed Roller Unit 271  
Installing the Fuser Unit 266  
Installing the Optional 250-Sheet Feeder 42  
Installing the Optional Memory Module 39  
InternetServices 156  
IP Address 155

IP Filter 156  
IP Mode 154  
IPP 155  
IPv4 154, 155  
IPv6 154

## J

Jam Problems 195  
Job History 143  
Job Time-out 159

## K

Kensington lock 36

## L

Labels 164, 165  
Landscape 148  
Lattice pattern 231  
Layout 153  
LCD 35  
LCD Panel 35  
    messages 240  
LetterH Dup Mode 163  
Light Card 164  
LineTermination 151  
Liquid crystal display 35  
Loading Envelope in the SSF 111  
Loading Envelope in the Standard 250-Sheet  
    Tray 107  
Loading Letterhead in the Optional 250-Sheet  
    Feeder 109  
Loading Letterhead in the SSF 112  
Loading Letterhead in the Standard 250-Sheet  
    Tray 109  
Loading print media 103  
    Optional 250-Sheet Feeder 105  
    SSF 110  
    Standard 250-Sheet Tray 105  
Login Error 168  
Low Toner Msg 163  
LPD 155  
LW Gloss Card 164, 165

## M

main components 32  
Maintenance 245  
Maintenance Mode 163  
managing  
    printer 278  
Memory Module 39  
Menu button 35  
messages

- LCD panel 240
- SimpleMonitor 241
- Meter Readings 145
- meter readings
  - total printed pages 282
- meters
  - total page counts 282
- mm / inch 160
- Mottle 214
- moving
  - printer 283
- Multiple-Up 281

## N

- network basics 57
- Network Connection 62
- Network connection setup 75
- No Acct User Prt 162
- Non-Genuine 167
- Non-Genuine Mode 243

## O

- OK button 35
- Online Services 293
- Operator Panel 33, 35
- Optional 250-Sheet Feeder 33, 182
- Ordering supplies 272
- Orientation 148
- Other Problems 234
- Output Color 151, 153, 154
- Output Size 147, 152
- Output Tray 33
- Output Tray Extension 33

## P

- Panel 155
- Panel Lock 168, 173
- Panel Settings 143
- Panel Settings Page 47
- Paper jam location 182
- Paper Select Mode 154
- Paper Tray 146
- Parts name 32
- Password 152
- PCL Fonts List 143
- PCL Macro List 143
- PCL Settings 146
- PDF Fonts List 143
- PDF Settings 151
- Peer-to-Peer 77
- Plain 164
- Port Status 157
- Port9100 155

- Portrait 148
- Power Connector 34
- Power Saver Time 158, 176
- Power Switch 34
- Preparing Printer Hardware 37
- print driver (Macintosh)
  - Installing print driver 81
- print driver (Linux)
  - Installing print driver 82
- print driver (Windows)
  - Installing print driver 71
- print driver pre-install status 72
- Print ID 161
- Print Media
  - Optional 250-Sheet Feeder 102
  - Single Sheet Feeder (SSF) 100
  - Standard 250-Sheet Tray 101
- Print media 281
- print media
  - dimensions 99
- Print Meter 143
- Print Mode 152
- Print Quality Problems 203
- Print Text 161
- printer
  - managing 278
  - moving 283
- Printer Settings 137, 143
- Printer software 51
- printer status
  - checking with SimpleMonitor 280
- Printing 117
- Printing a Report Page 136
- printing basics 93
- Printing Custom Size Paper 132
- Printing on Custom Size Paper
  - with Mac OS X driver 133
  - with Windows print driver 133
- Printing PDF Files Using PDF Bridge 122
- Printing Problems 201
- Problems With Installed Optional Accessories 233
- Product Features 25
- Protocol 155
- PS Error Report 153
- PS Fonts List 143
- PS Job Time-out 153
- PS Settings 153

## Q

- Quantity 150, 151

## R

- RAM Disk 162
- RARP 155
- Ready LED 35
- recycling supplies 275
- Removing options 285
- Removing Paper Jam 180
  - From Duplexer 191
  - From Fuser Unit 189
  - From Optional 250-sheet Feeder 192
  - From SSF 183
  - From Standard 250-sheet Tray 186
- Removing the Drum Cartridge 258
- Removing the Feed Roller Unit 270
- Removing the Fuser Unit 264
- Removing the optional 250-sheet feeder 288
- Removing the optional memory module 286
- Removing the Toner Cartridges 254
- Replacing the Feed Roller Unit 269
- Report/List 143
- Reset Fuser 166
- Resetting to Factory Defaults 177

## S

- safety
  - electrical 15
  - operational 19
- Sample Print 120
- Secure Print 120
- Secure Settings 167
- Securing the Printer 36
- Security Slot 34, 36
- Selecting Options (Macintosh) 130
- Selecting Options (Windows) 127
- Selecting Printing Options 126
- Selecting Printing Preferences (Windows) 126
- Sending print job 118
- Setting Paper Sizes 115
- Setting Paper Types 116
- Setting the IP Address 63
- Setup disk creation tool 56
- Shared printing 76
- Side Button 33
- Side Cover 33
- SimpleMonitor 55
  - alerts 241
- Single Sheet Feeder (SSF) 33, 182
- Slow Scan 230
- SMB (NetBEUI) 155
- SMB (TCP/IP) 155
- SNMP (UDP/IP) 155
- Specification 27
- Standard 250-Sheet Tray 33, 182

- StatusMessenger 156
- Stored Documents 144
- Stored Print 120
- Storing consumables 277
- Storing print media 276
- Straightest lines 230
- Subnet Mask 155
- Substitute Tray 162
- Supplies
  - recycling 275
  - when to order 274
- Supported Print Media 98
- Symbol Set 149
- System Settings 157

## T

- TCP/IP 154
- TCP/IP and IP Addresses 64
- Technical Support 292
- Telnet 156
- Toner Cartridge 33
- Toner Refresh 166
- Tray 1 170
- Tray 2 172
- Tray Settings 169
- Troubleshooting 179

## U

- Usable Print Media 100
- USB Connection Setup 74
- USB port 34, 59
- USB Settings 157
- Using the Single Sheet Feeder 113

## V

- Verifying IP settings 69

## W

- Web Services on Devices 138
- When to Order Supplies 274
- Width Guides 33
- width guides 106
- Wired Network 154
- WSD 138, 155

## Free Manuals Download Website

<http://myh66.com>

<http://usermanuals.us>

<http://www.somanuals.com>

<http://www.4manuals.cc>

<http://www.manual-lib.com>

<http://www.404manual.com>

<http://www.luxmanual.com>

<http://aubethermostatmanual.com>

Golf course search by state

<http://golfingnear.com>

Email search by domain

<http://emailbydomain.com>

Auto manuals search

<http://auto.somanuals.com>

TV manuals search

<http://tv.somanuals.com>