

Enterprise Server S80
pSeries 680 Model S85



Installation Guide

First Edition (November 2000)

Before using this information and the product it supports, read the information in “Safety Notices” on page v, “Appendix B. Environmental Notices” on page 43, and “Appendix C. Notices” on page 45.

©International Business Machines Corporation 2000. All rights reserved.

Note to U.S. Government Users - Documentation related to restricted rights - Use, duplication, or disclosure is subject to the restrictions set forth in the GSA ADP Schedule Contract with IBM Corp.

Contents

Safety Notices	v
Electrical Safety	v
Laser Safety Information	vi
Data Integrity and Verification	vii
About This Book	ix
ISO 9000	ix
Online Publications.	ix
Related Publications	ix
Trademarks	x
Chapter 1. System Installation Procedure	1
Step 1. Inventory	1
Step 2. Observe this Safety Notice During Installation	1
Step 3. Check the Customer Environment	2
Step 4. Check Customer Outlets	3
Step 5. Set Up the System Racks	4
Step 6A. Attach the I/O Rack to a Concrete Floor.	7
Attaching the I/O Rack to a Concrete Floor	8
Attaching the I/O Rack to a Concrete Floor Beneath a Raised Floor	10
Step 6B. Attach the System Rack to a Concrete Floor	14
Attaching the System Rack to a Concrete Floor	15
Attaching the System Rack to a Concrete Floor Beneath a Raised Floor.	16
Step 7. Attach the Front Electrical Outlet	18
Step 8. Attach the Rear Electrical Outlet	22
Step 9. Remove the Shipping Brackets and Install Covers	26
Step 10. Install the I/O Rack Door Guide	27
Step 11. Connect the Operator Panel Cable and the JTAG Cable Between the Racks	28
Step 12. Connect RIO and SPCN Cables Between the Racks	28
Step 13. Set Up Attached Devices	28
Step 14. Update the Device Records	29
Step 15. Attach External Devices.	29
Step 16. Connect the Power	29
Step 17. Power On and Check Out the System	29
Checklist If Problems Occur	29
Step 18. Service Processor Setup and Test	30
Step 19. Install the Modem and Electronic Service Agent.	30
Step 20. Finish the Installation	30
Chapter 2. Using the System Verification Procedure	33
Chapter 3. Installing Options for Your System	37
Appendix A. Communications Statements	39
Federal Communications Commission (FCC) Statement	39

European Union (EU) Statement	39
International Electrotechnical Commission (IEC) Statement	40
United Kingdom Telecommunications Safety Requirements	40
Avis de conformité aux normes du ministère des Communications du Canada	40
Canadian Department of Communications Compliance Statement	40
VCCI Statement	40
Electromagnetic Interference (EMI) Statement - Taiwan	41
Radio Protection for Germany	41
Appendix B. Environmental Notices	43
Product Recycling and Disposal	43
Environmental Design	43
Unit Emissions	43
Appendix C. Notices	45
Appendix D. Cabling the System Rack and I/O Rack	47
Connecting JTAG and Operator Panel Cables	48
I/O Rack Rear Locations	49
I/O Drawer Locations.	50
10 EIA Unit I/O Drawer Front View	50
10 EIA Unit I/O Drawer Rear View	51
10 EIA Unit I/O Drawer System board Locations.	53
Service Processor Card Locations	55
Fan Monitor Control (FMC) Card Locations (10 EIA Unit I/O Drawer)	56
Power Distribution Board Locations	56
Connecting RIO and SPCN Cables	57
Appendix E. System Records	63
Record the Identification Numbers	63
S80 and S85 System Rack.	63
S80 and S85 System Rack Memory Configuration	63
S80 and S85 System Rack Cabling Configurations - RIO Cabling	63
S80 and S85 System Rack Cabling Configurations - SPCN Cabling	64
Primary I/O Drawer Device Records	65
Additional I/O Drawer Device Records	68
Index	71
Reader's Comments — We'd Like to Hear From You	73

Safety Notices

A *danger* notice indicates the presence of a hazard that has the potential of causing death or serious personal injury.

A *caution* notice indicates the presence of a hazard that has the potential of causing moderate or minor personal injury.

Electrical Safety

Observe the following safety instructions any time you are connecting or disconnecting devices attached to the workstation.

DANGER

An electrical outlet that is not correctly wired could place hazardous voltage on metal parts of the system or the devices that attach to the system. It is the responsibility of the customer to ensure that the outlet is correctly wired and grounded to prevent an electrical shock.

Before installing or removing signal cables, ensure that the power cables for the system unit and all attached devices are unplugged.

When adding or removing any additional devices to or from the system, ensure that the power cables for those devices are unplugged before the signal cables are connected. If possible, disconnect all power cables from the existing system before you add a device.

Use one hand, when possible, to connect or disconnect signal cables to prevent a possible shock from touching two surfaces with different electrical potentials.

During an electrical storm, do not connect cables for display stations, printers, telephones, or station protectors for communication lines.

CAUTION:

This product is equipped with a three-wire power cable and plug for the user's safety. Use this power cable with a properly grounded electrical outlet to avoid electrical shock.

DANGER

To prevent electrical shock hazard, disconnect the power cable

CAUTION:

This unit has more than one power supply cord. To reduce the risk of electrical shock, disconnect two power supply cords before servicing.

Laser Safety Information

The optical drive in this system unit is a laser product. The optical drive has a label that identifies its classification. The label, located on the drive, is shown below.

CLASS 1 LASER PRODUCT LASER KLASSE 1 LUOKAN 1 LASERLAITE APPAREIL À LASER DE CLASSE 1 IEC 825:1984 CENELEC EN 60 825:1991

The optical drive in this system unit is certified in the U.S. to conform to the requirements of the Department of Health and Human Services 21 Code of Federal Regulations (DHHS 21 CFR) Subchapter J for Class 1 laser products. Elsewhere, the drive is certified to conform to the requirements of the International Electrotechnical Commission (IEC) 825 (1st edition 1984) and CENELEC EN 60 825:1991 for Class 1 laser products.



CAUTION:

A class 3 laser is contained in the device. Do not attempt to operate the drive while it is disassembled. Do not attempt to open the covers of the drive as it is not serviceable and is to be replaced as a unit.

Class 1 laser products are not considered to be hazardous. The optical drive contains internally a Class 3B gallium-arsenide laser that is nominally 30 milliwatts at 830 nanometers. The design incorporates a combination of enclosures, electronics, and redundant interlocks such that there is no exposure to laser radiation above a Class 1 level during normal operation, user maintenance, or servicing conditions.

Data Integrity and Verification

IBM computer systems contain mechanisms designed to reduce the possibility of undetected data corruption or loss. This risk, however, cannot be eliminated. Users who experience unplanned outages, system failures, power fluctuations or outages, or component failures must verify the accuracy of operations performed and data saved or transmitted by the system at or near the time of the outage or failure. In addition, users must establish procedures to ensure that there is independent data verification before relying on such data in sensitive or critical operations. Users should periodically check the IBM support websites for updated information and fixes applicable to the system and related software.

About This Book

This book provides information on how to setup and install the system, use diagnostics, use service aids, and verify system operation. This book also provides information to help you solve some of the simpler problems that might occur.

ISO 9000

ISO 9000 registered quality systems were used in the development and manufacturing of this product.

Online Publications

RS/6000 publications are available online. To access the online books, visit our Web site at: http://www.rs6000.ibm.com/resource/hardware_docs/

Related Publications

The following publications are available:

- The *Enterprise Server S80, p Series 680 Model S85 Service Guide*, order number SA38-0560, contains reference information, maintenance analysis procedures (MAPs), error codes, removal and replacement procedures, and a parts catalog.
- The *Diagnostic Information for Multiple Bus Systems*, order number SA38-0509, contains diagnostic information, service request numbers (SRNs), and failing function codes (FFCs).
- The *IBM RS/6000 Adapters, Devices, and Cable Information for Multiple Bus Systems*, order number SA38-0516 contains information about adapters, devices, and cables for your system. This manual is intended to supplement the service information found in the *Diagnostic Information for Multiple Bus Systems*.
- The *Site and Hardware Planning Information*, order number SA38-0508, contains specifications to help you do space and environmental planning before your system is installed.
- The *PCI Adapter Placement Reference*, order number SA38-0538, contains information about slot requirements for installing PCI adapters. This book is intended to be used to help plan and install PCI adapters for maximum performance from your system.
- *SSA Adapters User's Guide and Maintenance Information*, order number SA33-3272, is intended to help users and service representatives work with and diagnose problems with SSA adapters and devices.
- The *High Availability Cluster Multi-Processing for AIX, Version 4.3: Enhanced Scalability Installation and Administration Guide*, order number SC23-4284, is needed for HACMP/ES planning information.
- The *High Availability Cluster Multi-Processing for AIX, Version 4.3: Planning Guide*, order number SC23-4277, is needed for HACMP/ES planning information.

- The *7133 SSA Disk System: Operator Guide*, order number xxxxxxx, describes how to operate the 7133 SSA Disk System and how to install or replace disk drives to the system, and how to deal with problems encountered when using the system.
- The *7133 SSA Disk Subsystem: Service Guide*, order number xxxxxxx, is used by the service technician to repair system failures in the 7133 SSA Disk System.

Trademarks

The following trademarks apply to this information:

- AIX is a registered trademark of the International Business Machines Corporation.
- IBM is a registered trademark of the International Business Machines Corporation.
- Velcro is a trademark of Velcro Industries.

Chapter 1. System Installation Procedure

Follow the procedures in this chapter to install the Enterprise Server S80 and the p Series 680 Model S85. The estimated installation time for the system is:

Install Activity	3.5 Hours
Planning Activity	2.0 Hours
<hr/>	
Total Time	5.5 Hours

Step 1. Inventory

- The *About Your Machine* listing is in a plastic bag attached to the outside of the carton. Check the listing to verify that you have all the items that were shipped with the system.
- AIX operating system publications
- Enterprise Server S80, p Series 680 Model S85 User's Guide, order number SA38-0557
- Enterprise Server S80, p Series 680 Model S85 Service Guide, SA38-0560
- Enterprise Server S80, p Series 680 Model S85 Installation Guide, order number SA38-0582 (this book)
- *Diagnostic Information for Multiple Bus Systems*, order number SA38-0509
- *IBM RS/6000 Adapters, Devices, and Cable Information for Multiple Bus Systems*, order number SA38-0516
- *PCI Adapter Placement Reference*, order number SA38-0538.
- System Unit Safety Information, order number SA23-2652
- *Electronic Service Agent for RS/6000 User's Guide*, order number ZA38-0383
- Support Information and Warranty.

Verify with the customer that the following items are available. You will need them to complete this installation.

1. A floor plan, showing where to place each rack.
2. A console, including cables and a power source.
3. A modem for the electronic customer-support function (if the customer ordered this function). This includes the correct telephone jack, cables, and a power source.

Step 2. Observe this Safety Notice During Installation

Note: For a translation of this notice, see the *System Unit Safety Information* manual.

DANGER

An electrical outlet that is not correctly wired could place hazardous voltage on metal parts of the system or the devices that attach to the system. It is the responsibility of the customer to ensure that the outlet is correctly wired and grounded to prevent an electrical shock.

Before installing or removing signal cables, ensure that the power cables for the system unit and all attached devices are unplugged.

When adding or removing any additional devices to or from the system, ensure that the power cables for those devices are unplugged before the signal cables are connected. If possible, disconnect all power cables from the existing system before you add a device.

Use one hand, when possible, to connect or disconnect signal cables to prevent a possible shock from touching two surfaces with different electrical potentials.

During an electrical storm, do not connect cables for display stations, printers, telephones, or station protectors for communication lines.

CAUTION:

This product is equipped with a three-wire power cable and plug for the user's safety. Use this power cable with a properly grounded electrical outlet to avoid electrical shock.

CAUTION:

This unit has more than one power supply cord. To reduce the risk of electrical shock, disconnect two power supply cords before servicing.

CAUTION:

Energy hazard, remove power before servicing. Disconnect two power supply cords.

Step 3. Check the Customer Environment

1. Verify with your Installation Planning Representative or the customer that any station-protector boxes used are correctly installed according to the Site and Hardware Planning Information manual.
2. Make sure the customer is aware that the recommended temperature for IBM products is 24° C (75° F) and the recommended relative humidity is 45%. The acceptable operating temperature range is 10° C (50° F) to 38° C (100° F), and the acceptable operating humidity range is 8% to 80%.
3. Make sure the customer is aware that the front and rear service clearances around the system rack and I/O rack should be 36 inches (900mm). The service clearances are important for proper air circulation, weight distribution, and the safety of both the service representative and the customer.

Refer to "Specifications" in the Enterprise Server S80 p Series 680 Model S85 Service Guide, order number SA38-0560, for more planning information.

Step 4. Check Customer Outlets

Note: For a translation of this notice, see the *System Unit Safety Information* manual, order number SA23-2652.

CAUTION:

Do not touch the receptacle or the receptacle faceplate with anything other than your test probes before you have met the requirements in Step 8 below.

- ___ 1. Have the customer locate and turn off the branch circuit CB (circuit breaker). Attach tag S229-0237, which reads "Do Not Operate."

Note: All measurements are made with the receptacle faceplate in the normal installed position.

- ___ 2. Some receptacles are enclosed in metal housings. On receptacles of this type, perform the following steps:
- a. Check for less than 1 volt from the receptacle case to any grounded metal structure in the building, such as a raised-floor metal structure, water pipe, building steel, or similar structure.
 - b. Check for less than 1 volt from receptacle ground pin to a grounded point in the building.

Note: If the receptacle case or faceplate is painted, be sure the probe tip penetrates the paint and makes good electrical contact with the metal.

- ___ 3. Check the resistance from the ground pin of the receptacle to the receptacle case. Check resistance from the ground pin to building ground. The reading should be less than 1.0 ohm, which indicates the presence of a continuous grounding conductor.
- ___ 4. If any of the three checks made in substeps 2 and 3 are not correct, ask the customer to remove the power from the branch circuit and make the wiring corrections; then check the receptacle again.

Note: Do not use the digital multimeter to measure grounding resistance.

- ___ 5. Check for infinite resistance between the phase pins. This is a check for a wiring short.

Note: For a translation of this notice, see the *System Unit Safety Information* manual, order number SA23-2652.

CAUTION:

If the reading is other than infinity, do not proceed! Have the customer make necessary wiring corrections before continuing. Do not turn on the branch circuit CB until all the above steps are satisfactorily completed.

- ___ 6. Have the customer turn on the branch circuit CB. Measure for appropriate voltages between phases. If no voltage is present on the receptacle case or grounded pin, the receptacle is safe to touch.
- ___ 7. With an appropriate meter, verify that the voltage at the outlet is correct.
- ___ 8. Verify that the grounding impedance is correct by using the ECOS 1020, 1023, B7106, or an appropriately approved ground impedance tester.

Note: Do *not* use the 120-volt convenience outlets inside a machine to power the tester.

Step 5. Set Up the System Racks

Note: For a translation of this notice, see the *System Unit Safety Information* manual.

CAUTION:

The stabilizer must be firmly attached to the bottom of the I/O rack to prevent the rack from turning over when the drawers are pulled out of the rack. Do not pull out or install any drawer or feature if the stabilizer is not attached to the rack.

Shipping material must be removed, and the system rack and I/O rack and place them where they are to be installed before installation can begin. If this has not been done, consult the customer and the marketing representative as necessary.

1. Remove all packing and tape, if present, from the system rack and the I/O rack.
2. Position the racks according to the customer floor plan.

Note: As viewed from the front, position the primary I/O rack (the primary I/O rack contains the service processor) on the right side of the system rack. A clearance of 10 cm (4 inches) between the racks is required to allow access to the I/O rack door.

If you are attaching the racks to a concrete floor or a raised floor, refer to “Step 6A. Attach the I/O Rack to a Concrete Floor” on page 7, and then return here.

3. On both racks, lock each caster wheel by tightening the thumbscrew on the caster.

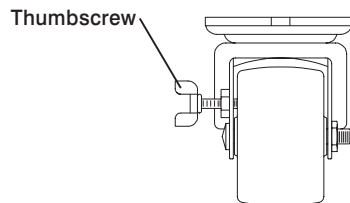

4. Adjust the leveling feet on the I/O rack by doing the following:
 - a. Loosen the locking nut by turning the locking nut counter-clockwise (away from the bottom of the rack).

- b. Adjust the height of the leveling feet by rotating the leveling feet either upward or downward according to the level of the surface on which the rack is placed. Repeat this for the remaining leveling feet as needed.
- c. When the rack is leveled, tighten the locking nuts on all of the leveling feet.

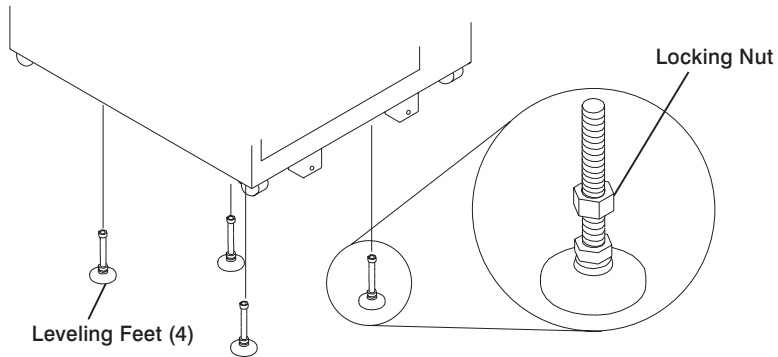

- 5. Align the slots in the stabilizer with the mounting holes in the bottom front of the I/O rack.
- 6. Ensure that the base of the stabilizer rests firmly on the floor.
- 7. Install the two mounting screws and hand-tighten.

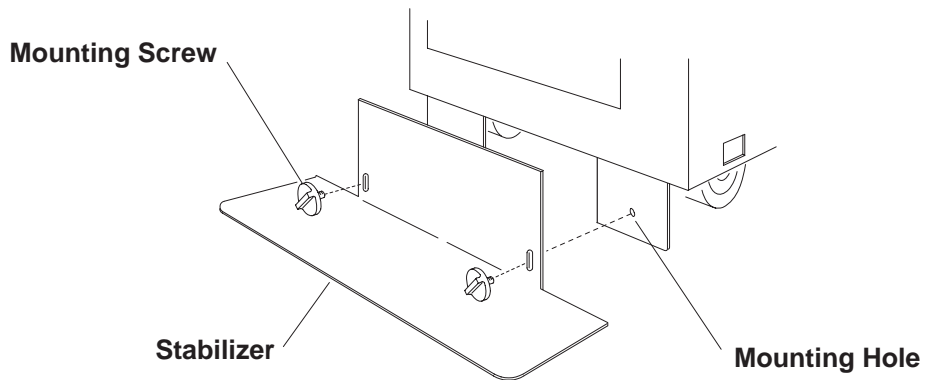

- 8. Use the crank supplied with the system unit to alternately tighten the mounting screws until they are firmly seated.

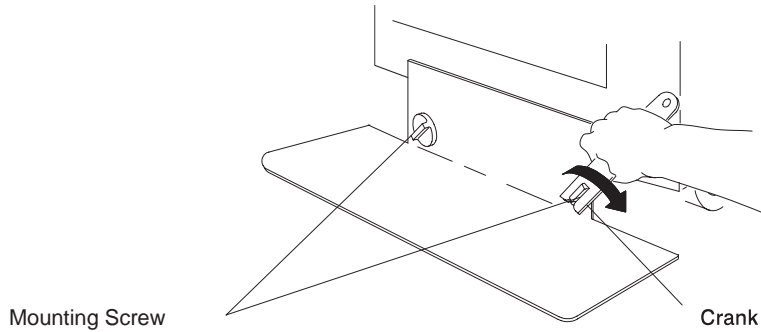

9. Hang the crank and tightening rod on the bracket near the bottom of the right wall inside the back of the rack.

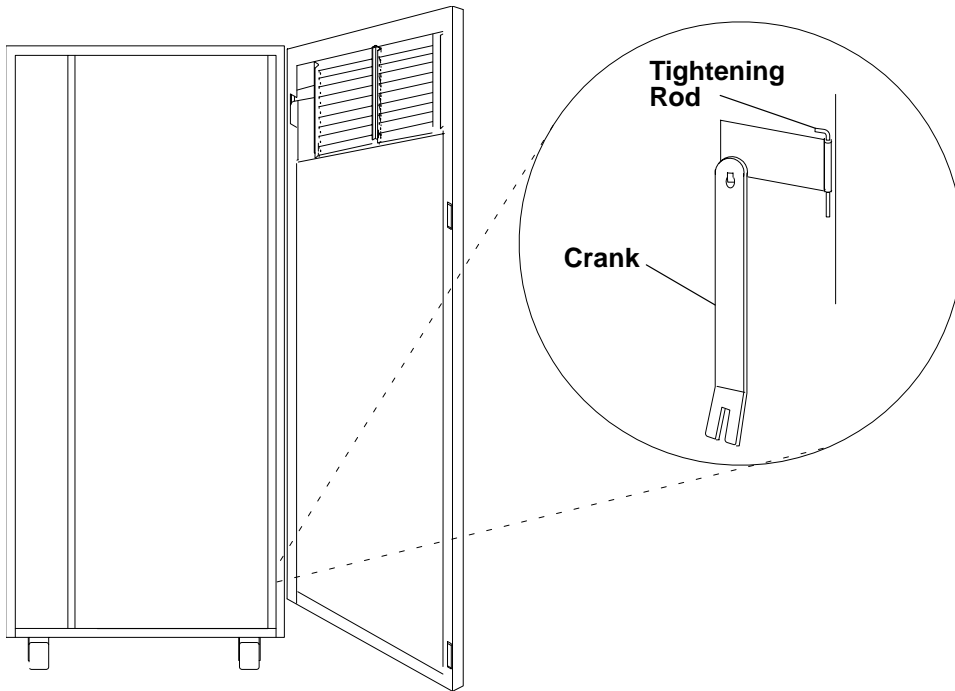

10. Install the rear stabilizer on the I/O rack, as follows:
 - a. Loosen the lower screws on the stabilizer assembly.
 - b. Slide the stabilizer assembly onto the bottom of the rack.
 - c. Install screws at the top of the stabilizer assembly and tighten.
 - d. Tighten the lower screws on the stabilizer assembly.

- e. Adjust the bolts to the floor to ensure that the stabilizer is level and does not move.

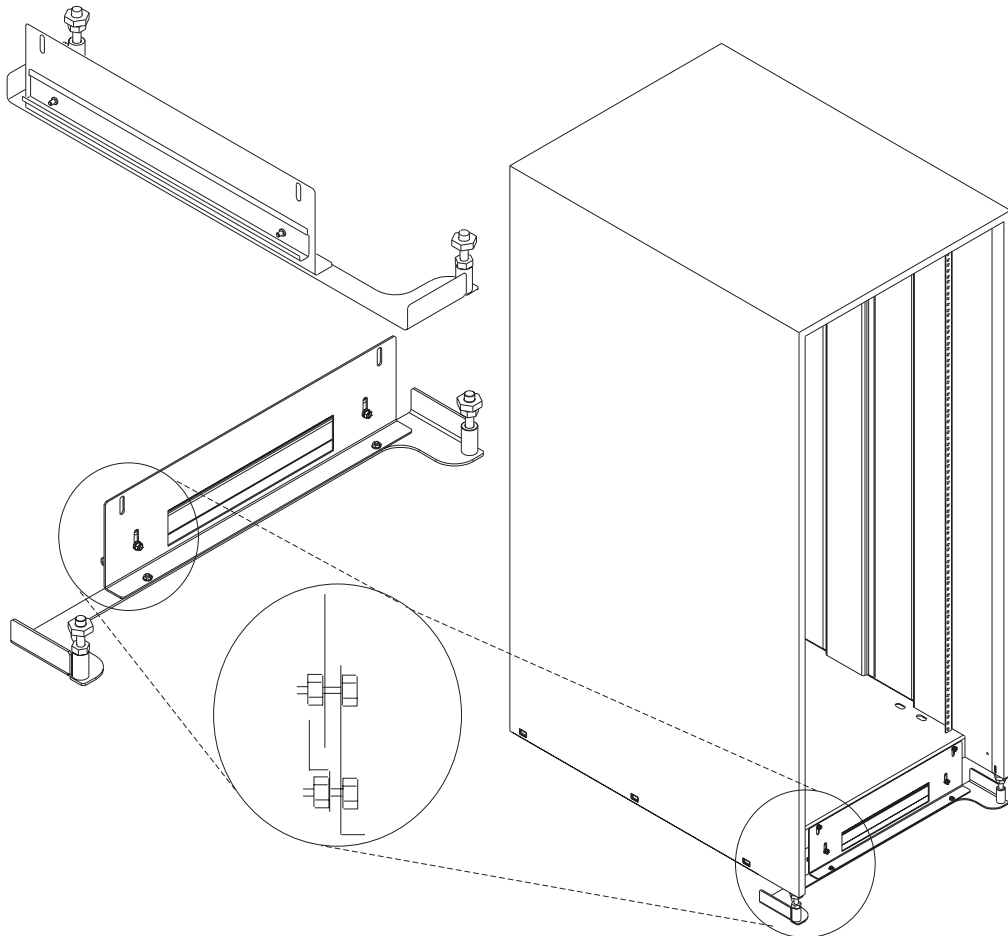

11. If head protectors are installed, remove them from diskette drives.

Step 6A. Attach the I/O Rack to a Concrete Floor

Perform this step if the I/O rack is to be attached to a concrete floor or a concrete floor beneath a raised floor.

Notes:

1. Ensure that the primary I/O rack (the primary I/O rack contains the service processor) is positioned on the right side of the system rack when viewed from the front. A clearance of 10 cm (4 inches) between the racks is required to allow access to the I/O rack door.
2. If you are attaching the I/O rack:

- To a concrete floor, continue with “Attaching the I/O Rack to a Concrete Floor”.
- To a concrete floor below a raised floor, go to “Attaching the I/O Rack to a Concrete Floor Beneath a Raised Floor” on page 10.

If you are not attaching the I/O rack to a concrete floor, continue with “Step 7. Attach the Front Electrical Outlet” on page 18.

Attaching the I/O Rack to a Concrete Floor

The customer is responsible for attaching the rack-mounting plates to the concrete floor.

Note: Because of the length of the four rack-mounting bolts, the drawer located in the bottom position of the rack *must* be removed to install the four rack-mounting bolts to the floor.

1. Mark the floor around the edge of each leveling foot.
2. Place the two mounting plates in the approximate mounting locations under the rack.
3. To align the rack over the mounting plates, do the following:
 - a. Place the four rack-mounting bolts through the mounting holes at the bottom of the rack.
 - b. Position the mounting plates under the four rack-mounting bolts so that the mounting bolts are centered directly over the tapped holes. Insert the rack-mounting bolts three or four rotations into the tapped holes.
4. Mark the floor around the edge of both mounting plates.
5. Remove the mounting bolts from the threaded holes.
6. To access the holes in the mounting plates, raise the four leveling feet, and then move the rack away from the mounting plates.
7. Mark the floor at the center of each hole in the mounting plates (including the tapped holes).
8. Remove the two mounting plates from the marked locations.
9. At the marked location of the tapped mounting holes, drill two holes approximately 1 inch to allow clearance for the ends of the two rack-mounting bolts. The ends of the rack-mounting bolts may protrude past the thickness of the mounting plate.

Note: A minimum of three anchor bolts for each mounting plate must be used to mount the plates to the concrete floor. Because some of the drilled holes may be aligned with concrete reinforcement rods below the surface of the concrete floor, some of the drilled holes may not be usable. For each mounting plate, select at least three usable holes, two that are on opposite sides and opposite ends of each other, and one hole at the center.

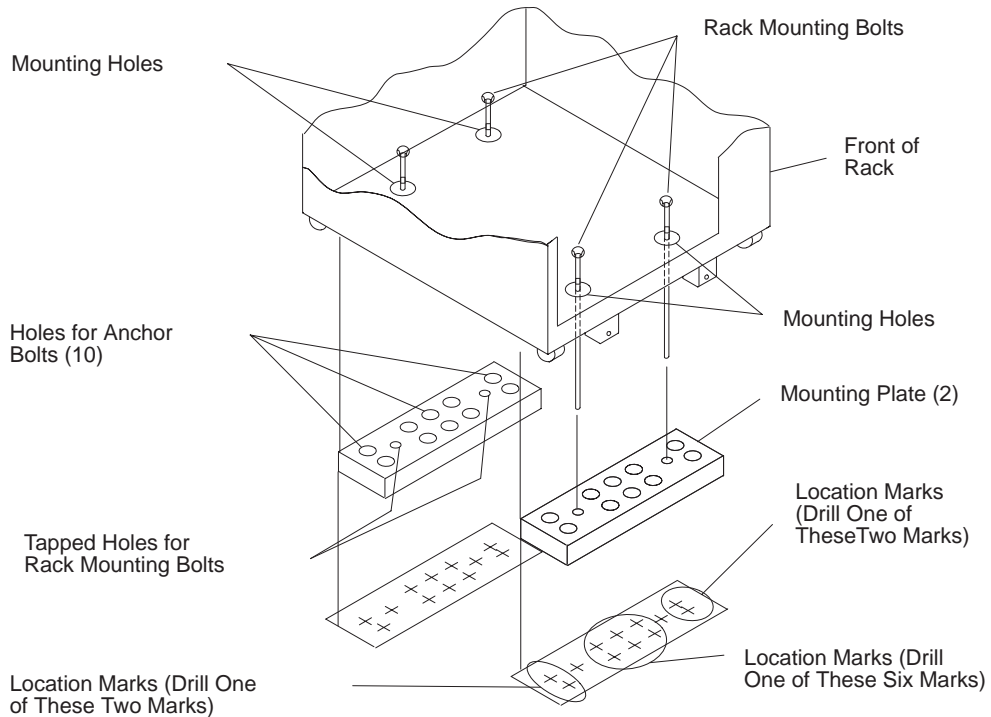

10. Drill one hole in each group of anchor bolt location marks as indicated on the marked floor.
11. Using at least three anchor bolts for each mounting plate, mount the two mounting plates to the concrete floor.
12. Using the location marks for leveling feet as a guide, reposition the rack over the mounting plates.
13. Place the four rack-mounting bolts through the four metal washers, and then through the four plastic isolator washers. The flat side of the plastic isolator washer must be facing upward.
14. To further align the rack over the mounting plates, do the following:
 - a. Place the four rack-mounting bolts (with the four plastic isolator washers) through the mounting holes in the bottom of the rack.
 - b. Align the four mounting bolts to the location of the four tapped holes in the two mounting plates.
 - c. Insert the rack-mounting bolts three to four rotations into the tapped holes.

Note: The bottom of the four leveling feet must be positioned over the four plastic isolator pads when the rack is leveled.

If you are installing an ac-powered rack, do not use the four plastic isolator pads.

15. Place the four plastic isolator pads under the four leveling feet, and then level the rack using the four adjustable leveling feet.
16. Tighten the locking nuts on the leveling feet.

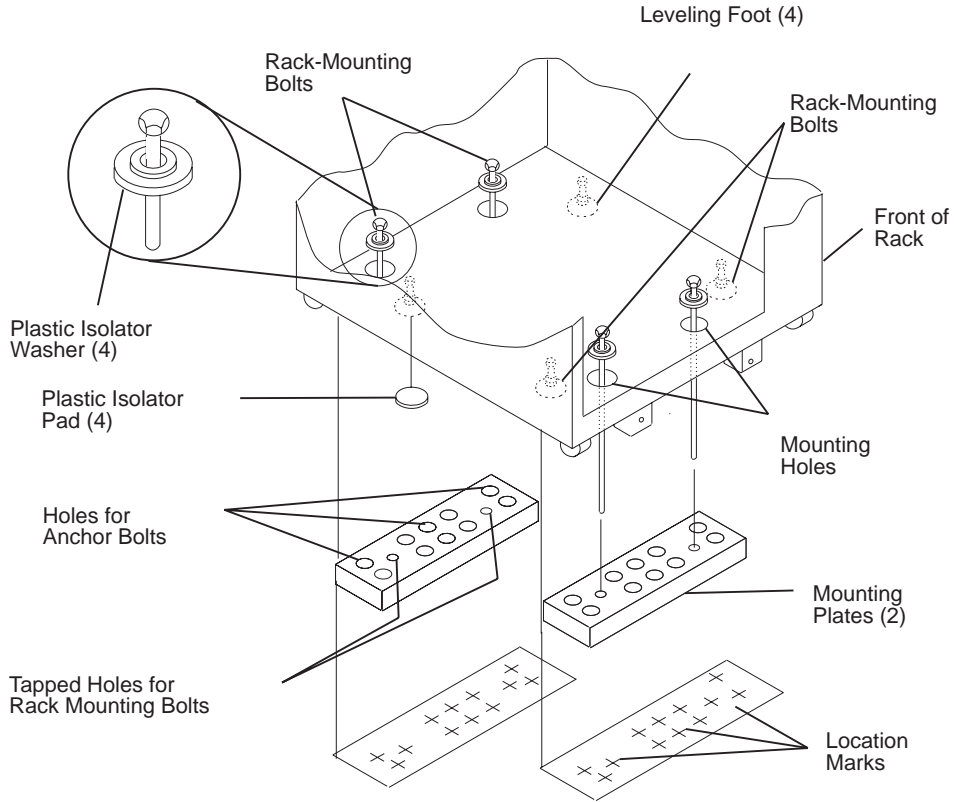

17. Tighten the four rack-mounting bolts into the two mounting plates.
18. If a drawer was removed from the bottom position of the rack, reinstall it.

Attaching the I/O Rack to a Concrete Floor Beneath a Raised Floor

The customer is responsible for obtaining the services of a mechanical contractor to attach the rack-mounting plates on the raised floor with hardware that goes through the raised floor into the concrete floor below the raised floor. The mechanical contractor should determine that the raised floor support and the hardware used to attach the rack mounting plates is sufficient to meet the customer's requirements for the installation.

Note: Because of the length of the four rack-mounting bolts, the drawer located in the bottom position of the rack *must* be removed to install the four rack-mounting bolts to the floor.

1. Mark the floor around the edge of each leveling foot.

2. Place the two mounting plates in the approximate mounting locations under the rack.
3. To align the rack over the mounting plates, do the following:
 - a. Place the four rack-mounting bolts through the mounting holes at the bottom of the rack.
 - b. Position the mounting plates under the four rack-mounting bolts so that the mounting bolts are centered directly over the tapped holes. Insert the rack-mounting bolts three or four rotations into the tapped holes.
4. Mark the raised-floor panel around the edge of both mounting plates.
5. Remove the mounting bolts from the threaded holes.
6. To access the holes in the mounting plates, raise the four leveling feet, and then move the rack away from the mounting plates.
7. Mark the raised-floor panel at the center of each hole in the mounting plates (including the tapped holes).
8. Remove the two mounting plates from the marked locations.

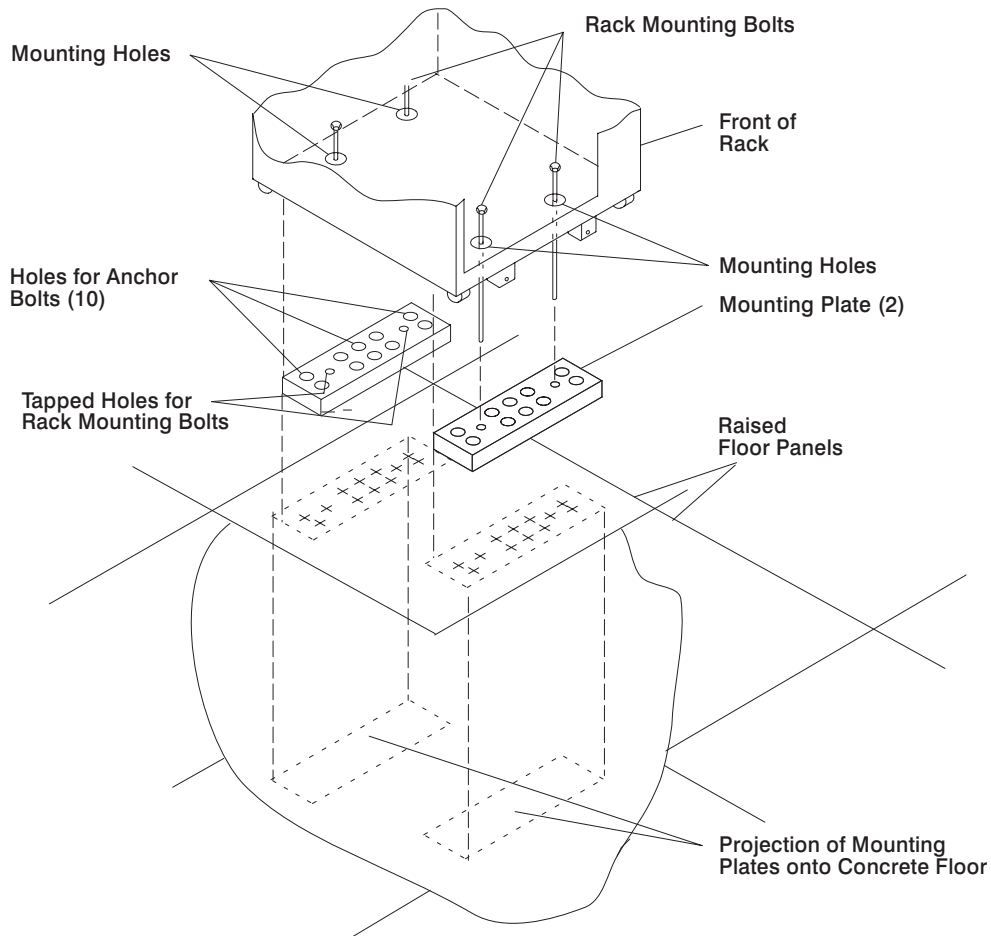

9. At the marked location of the tapped mounting holes, drill two holes approximately 1 inch to allow clearance for the ends of the two rack-mounting bolts. The ends of the rack-mounting bolts may protrude past the thickness of the mounting plate.

Note: A minimum of three anchor bolts for each mounting plate must be used to mount the plates to the raised-floor panel. For each mounting plate, select at least three usable holes, two that are on opposite sides and opposite ends of each other, and one hole at the center.

10. Drill one hole in each group of anchor bolt location marks as indicated on the marked raised floor panel.
11. Ensure that the marks for the holes for the anchor bolts in the concrete floor align with the holes in the raised floor panel.
12. Drill the holes in the concrete floor for the anchor bolts.

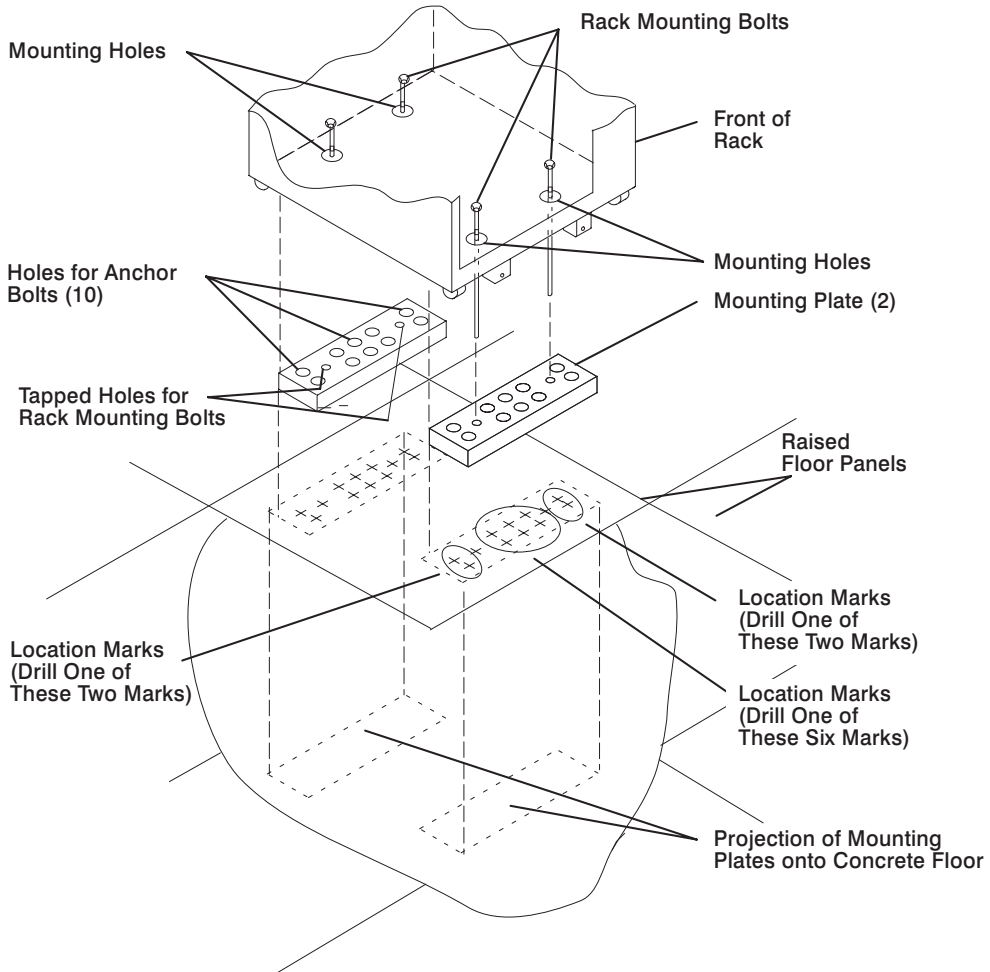

13. Place the two mounting plates on the locations indicated on the marked raised-floor panel.
14. Using at least three anchor bolts for each mounting plate, mount the two mounting plates through the raised-floor panel to the concrete floor.
15. Using the location marks for leveling feet as a guide, reposition the rack over the mounting plates.
16. Place the four rack-mounting bolts through the four metal washers, and then through the four plastic isolator washers. The flat side of the plastic isolator washer must be facing upward.
17. To further align the rack over the mounting plates, do the following:
 - a. Place the four rack-mounting bolts (with the four plastic isolator washers) through the mounting holes in the bottom of the rack.
 - b. Align the four mounting bolts to the location of the four tapped holes in the two mounting plates.

- c. Insert the rack-mounting bolts three to four rotations into the tapped holes.

Note: The bottoms of the four leveling feet must be positioned over the four plastic isolator pads when the rack is leveled. If you are installing an AC powered rack, do not use the four plastic isolator pads.

18. Place the four plastic isolator pads under the four leveling feet, and then level the rack using the four adjustable leveling feet.
19. Tighten the locking nuts on the leveling feet.

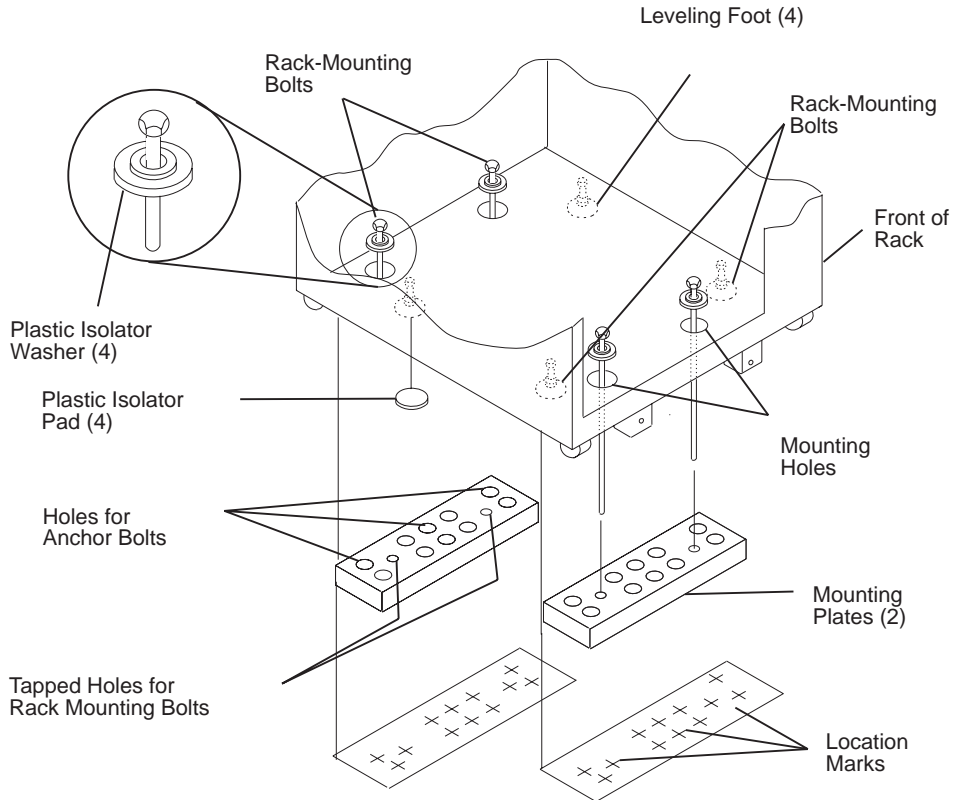

20. Tighten the four rack-mounting bolts into the two mounting plates.
21. If you are attaching an electrical outlet and mounting plate, skip to “Step 7. Attach the Front Electrical Outlet” on page 18 or “Step 8. Attach the Rear Electrical Outlet” on page 22 as appropriate, then return here.
22. If a drawer was removed from the bottom position of the rack, reinstall it.

Step 6B. Attach the System Rack to a Concrete Floor

Perform this step if the system rack is to be attached to a concrete floor or a concrete floor beneath a raised floor.

Notes:

1. Ensure that the primary I/O rack (the primary I/O rack contains the service processor) is positioned on the right side of the system rack when viewed from the front. A clearance of 10 cm (4 inches) between the racks is required to allow access to the I/O rack door.
2. If you are attaching the system rack:
 - To a concrete floor, continue with “Attaching the System Rack to a Concrete Floor”.
 - To a concrete floor below a raised floor, go to “Attaching the System Rack to a Concrete Floor Beneath a Raised Floor” on page 16.

If you are not attaching the system rack to a concrete floor, continue with “Step 7. Attach the Front Electrical Outlet” on page 18.

Attaching the System Rack to a Concrete Floor

The customer is responsible for attaching the rack-mounting plates to the concrete floor.

1. Install the 4 plate assemblies with the leveling feet, bushings and washers. Make sure that the leveling feet are backed off the floor level to allow space for the mounting plates.

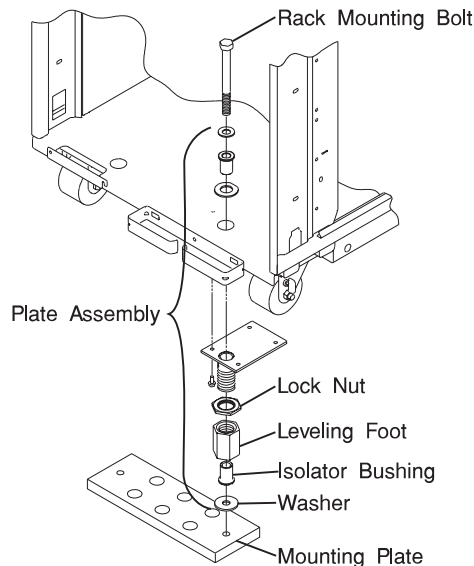

2. Place the mounting plates, front and rear, (note that they are different) in the approximate mounting position under the system rack.
3. To align the system rack over the mounting plate, do the following:
 - a. Place the four rack-mounting bolts through the plate assembly holes at the bottom of the rack (install the bushings and washers to ensure bolt positioning).

- b. Position the mounting plates under the four rack-mounting bolts so that the mounting bolts are centered directly over the tapped holes.
- c. Insert the rack-mounting bolts three or four rotations into the tapped holes.
4. Mark the floor around the edge of the mounting plates.
5. Remove the mounting bolts from the threaded holes.
6. Move the rack away from the mounting plates.
7. Mark the floor at the center of each hole in the mounting plate (including tapped holes).
8. Remove the mounting plates from the marked locations.
9. At the marked location of the tapped mounting holes, drill two holes approximately 1 inch to allow clearance for the ends of the two rack-mounting bolts. The ends of the rack-mounting bolts may protrude past the thickness of the mounting plate.

Note: A minimum of three anchor bolts for each mounting plate must be used to mount the plates to the concrete floor. Because some of the drilled holes may be aligned with concrete reinforcement rods below the surface of the concrete floor, some of the drilled holes may not be usable. For each mounting plate, select at least three usable holes, two that are on opposite sides and opposite ends of each other, and one hole at the center.

Drill one hole in each group of anchor bolt location marks as indicated on the marked floor.

10. Using at least three bolts for each mounting plate, mount the mounting plates to the concrete floor.
11. Reposition the system rack over the mounting plates.
12. Place the four rack-mounting bolts through the plate assemblies with the D-washer positioned so that the straight side of the washer is facing inward toward the system rack.
13. Place the isolator bushing inside the leveling foot with a washer between the isolator bushing and the floor plate.
14. Insert the rack-mounting bolts three or four rotations into the tapped holes.
15. Turn the leveling foot of the plate assembly down until it contacts the mounting plate, and then level the rack using the four leveling feet.
16. Lock the leveling feet by tightening the lock nut.
17. Tighten the four rack-mounting bolts into the mounting plates.

Attaching the System Rack to a Concrete Floor Beneath a Raised Floor

The customer is responsible for obtaining the services of a mechanical contractor to attach the rack-mounting plates on the raised floor with hardware that goes through the raised floor into the concrete floor below the raised floor. The mechanical contractor should determine that the raised floor support and the hardware used to attach the rack mounting plates is sufficient to meet the customer's requirements for the installation.

1. Install the 4 plate assemblies with the levelling feet, bushings, and washers. Make sure that the leveling feet are backed off the floor level to allow space for the mounting plates.

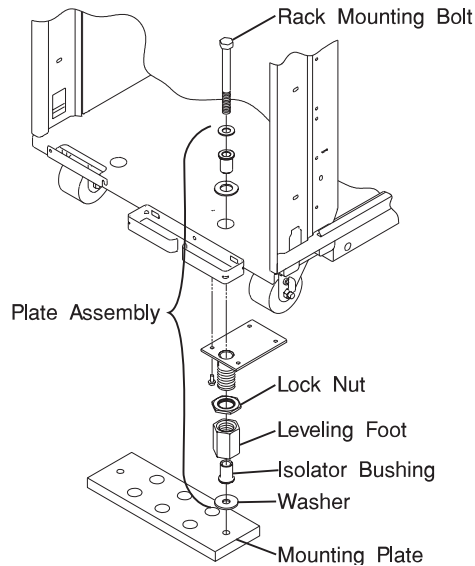

2. Place the mounting plates, front and rear, (note that they are different) in the approximate mounting position under the system rack.
3. To align the system rack over the mounting plate, do the following:
 - a. Place the four rack-mounting bolts through the plate assembly holes at the bottom of the rack (install the bushings and washers to ensure bolt positioning).
 - b. Position the mounting plates under the four rack-mounting bolts so that the mounting bolts are centered directly over the tapped holes.
 - c. Insert the rack-mounting bolts three or four rotations into the tapped holes.
4. Mark the raised-floor panel around the edge of both mounting plates.
5. Remove the mounting bolts from the threaded holes.
6. Move the rack away from the mounting plates.
7. Mark the raised floor at the center of each hole in the mounting plates (including the tapped holes).
8. Remove the two mounting plates from the marked locations.
9. At the marked location of the tapped mounting holes, drill two holes approximately 1 inch to allow clearance for the ends of the two rack-mounting bolts. The ends of the rack-mounting bolts may protrude past the thickness of the mounting plate.

Note: A minimum of three anchor plates for each mounting plate must be used to mount the plates to the concrete floor. Because some of the drilled holes may be aligned with concrete reinforcement rods below the surface of the

concrete floor, some of the drilled holes may not be usable. For each mounting plate, select at least three usable holes, two that are on opposite sides and opposite ends of each other, and one hole at the center.

10. Drill one hole in each group of anchor bolt location marks as indicated on the marked raised-floor panel.
11. Project the holes now in the raised-floor panel down to the concrete floor below. Ensure that the marks for the holes for the anchor bolts in the concrete floor align with the holes in the raised floor panel.
12. Drill the holes in the concrete floor for the anchor bolts.
13. Place the mounting plates on the locations on the marked raised-floor panel.
14. Using the three anchor bolts for each mounting plate, mount the two mounting plates through the raised-floor panel to the concrete floor.
15. Reposition the system rack over the mounting plates.
16. Place the four rack-mounting bolts through the plate assemblies with the D-washer positioned so that the straight side of the washer is facing inward toward the system rack.
17. Place the isolator bushing inside the leveling foot with a washer between the isolator bushing and the floor plate.
18. Insert the rack-mounting bolts three or four rotations into the tapped holes.
19. Turn the leveling foot of the plate assembly down until it contacts the mounting plate, and then level the rack using the four leveling feet.
20. Lock the leveling feet by tightening the lock nut.
21. Tighten the 4 rack-mounting bolts into the mounting plates.

Step 7. Attach the Front Electrical Outlet

Attention: Refer to “Safety Notices” on page v before continuing.

Note: If the rack is on a raised floor without being attached to the concrete floor below the raised floor, a stabilizer must be installed instead of the front-electrical-outlet mounting plate. The front-electrical-outlet mounting plate cannot be installed on the rack when a stabilizer is installed.

1. After the customer has connected the power cable from the customer power source to the electrical outlet assembly, mount the electrical outlet assembly to the mounting plate using the two mounting screws (provided by the customer).

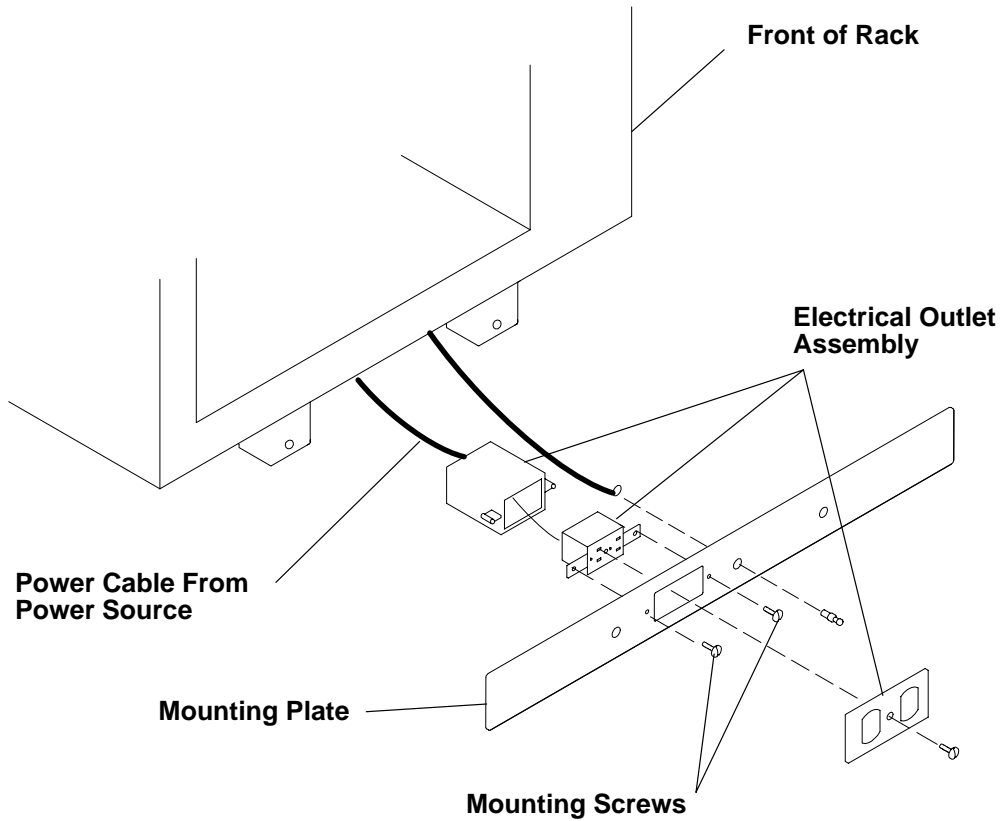

2. Place the ground-cable lug through the mounting hole of the mounting plate.
3. Connect the long end of the ground cable to the threaded side of the ground-cable lug (inside mounting plate), and then install and tighten the ground-lug nut.

Note: The two remaining connections of the ground cable are done in “Step 8. Attach the Rear Electrical Outlet” on page 22.

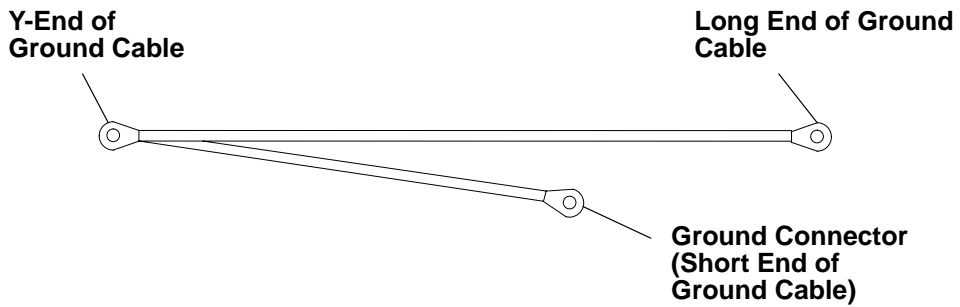
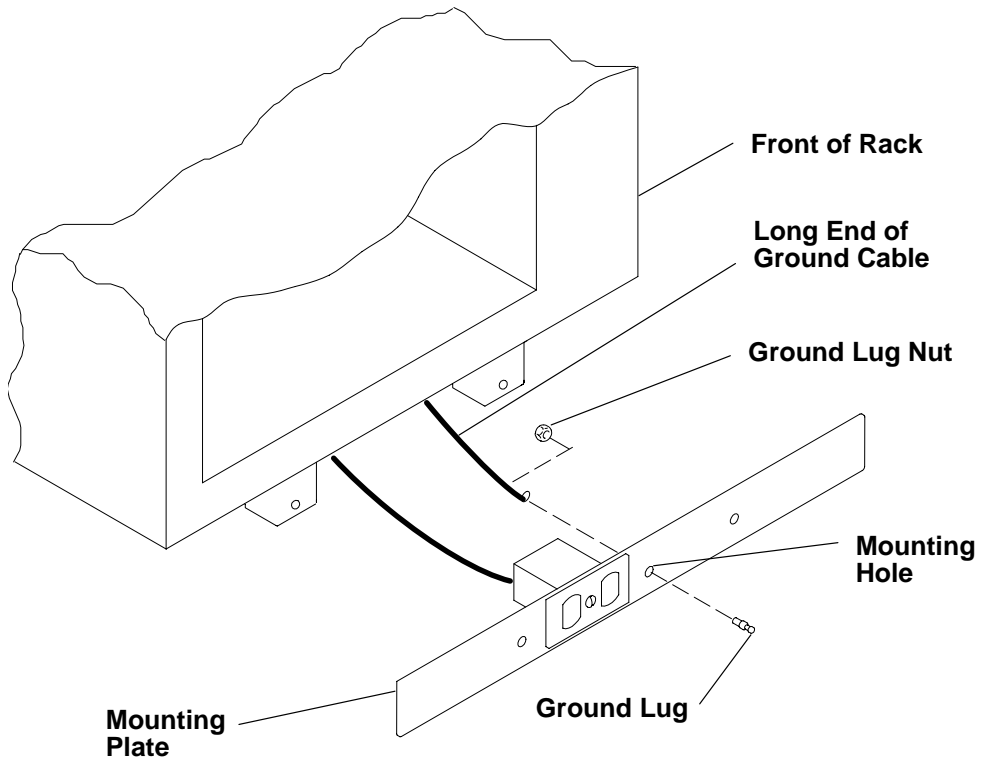

4. Find the crank (for installing the mounting screws) located inside the rear of the rack near the bottom of the right wall.

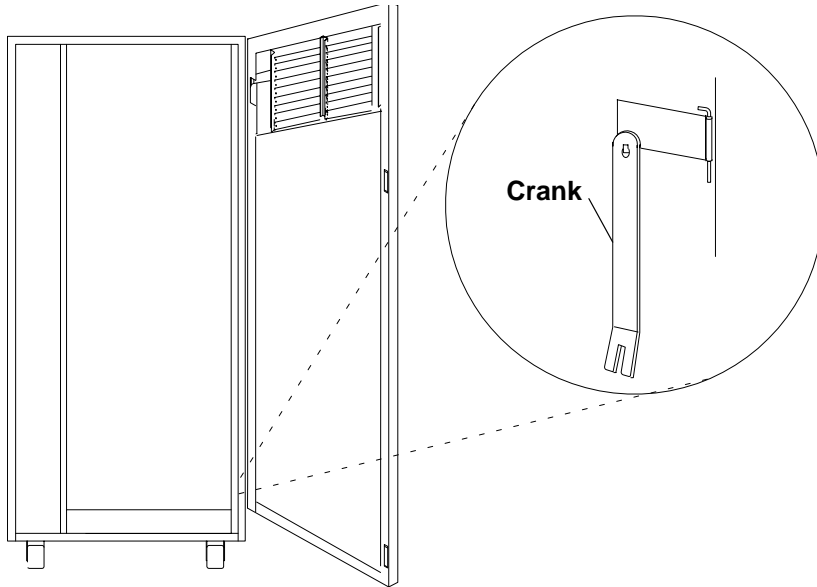

5. Align the holes of the mounting plate with the holes on the rack, and then install the two mounting screws.
6. Using the crank, tighten the two mounting screws.

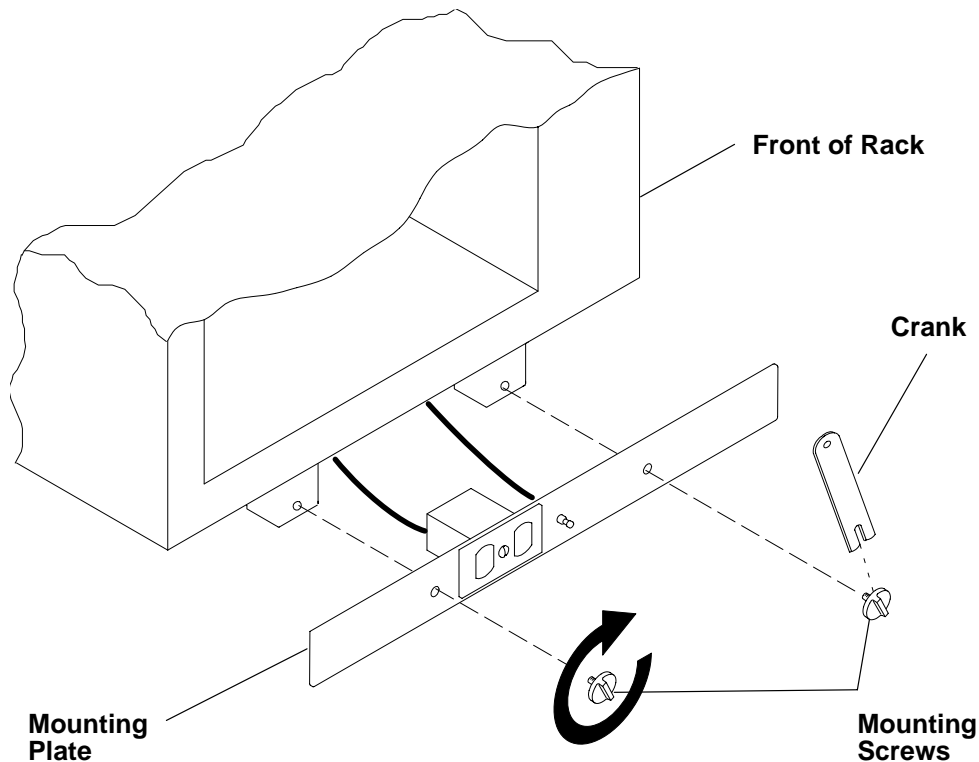

7. Store the crank inside the rear of the rack near the bottom of the right wall.

Notes:

1. If the customer does not want to connect an electrical outlet to the front mounting plate, install the mounting plate without the electrical outlet.
2. The customer is responsible for providing and connecting the electrical outlet assembly.

The customer is also responsible for providing and connecting the power cable from the customer power source to the front electrical outlet.

Step 8. Attach the Rear Electrical Outlet

Attention: Refer to “Safety Notices” on page v before continuing.

Note: The customer is responsible for providing and connecting the electrical outlet assembly.

The customer is also responsible for providing and connecting the power cable from the customer power source to the rear electrical outlet.

1. Open the rear door of the rack.

2. After the customer has connected the power cable from the customer power source to the electrical outlet assembly, mount the electrical outlet assembly to the mounting plate using the two mounting screws (provided by the customer).

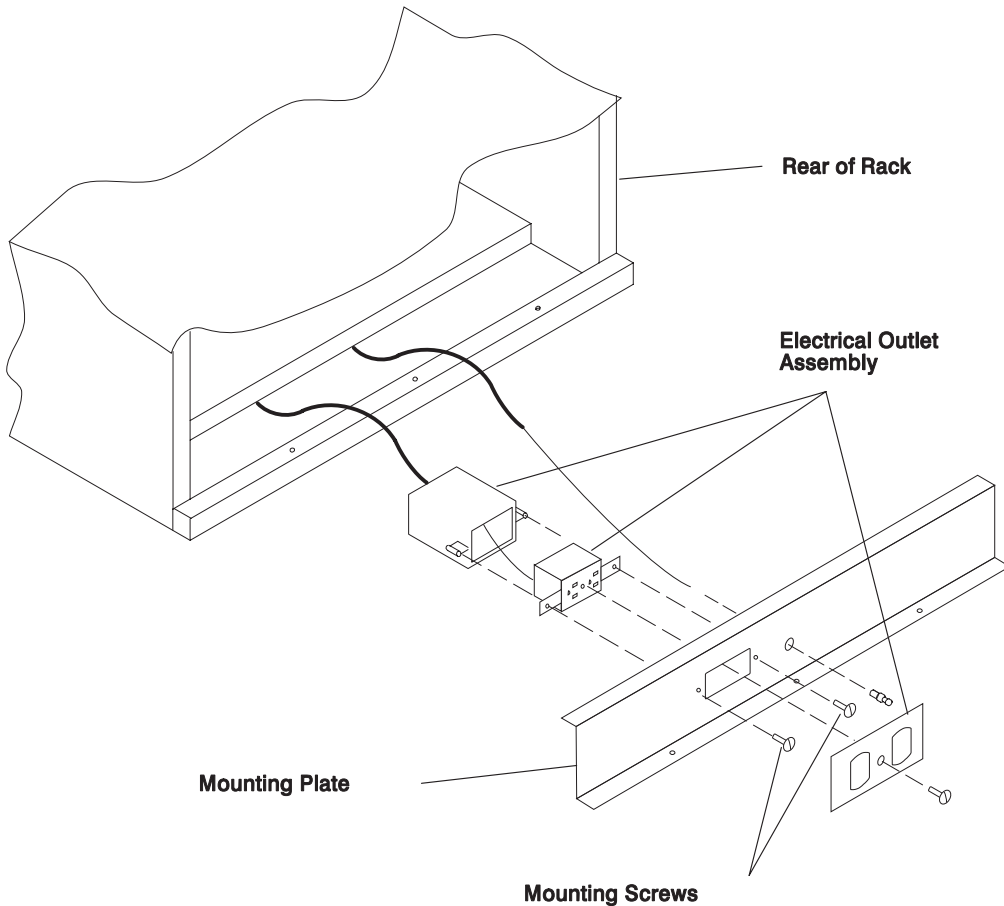

3. Place the ground cable lug through the mounting hole of the mounting plate.
4. Connect the short ground cable to the threaded side of the ground cable lug, and then install and tighten the ground lug nut.

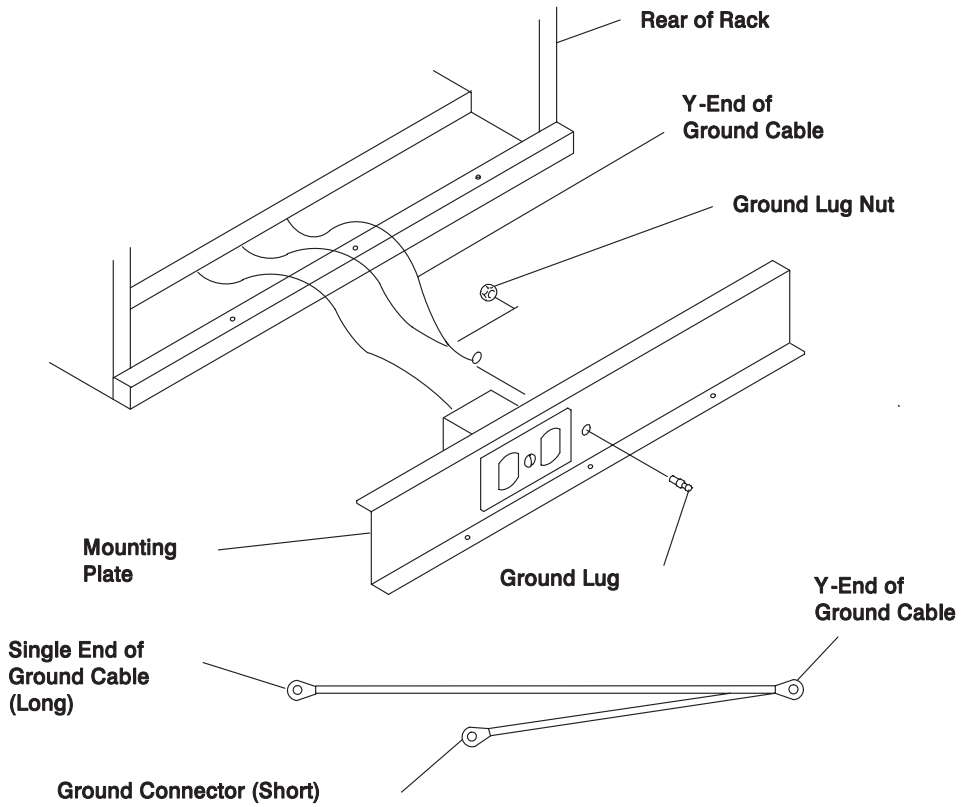

5. Attach the mounting plate to the rack by installing and tightening the three mounting screws.

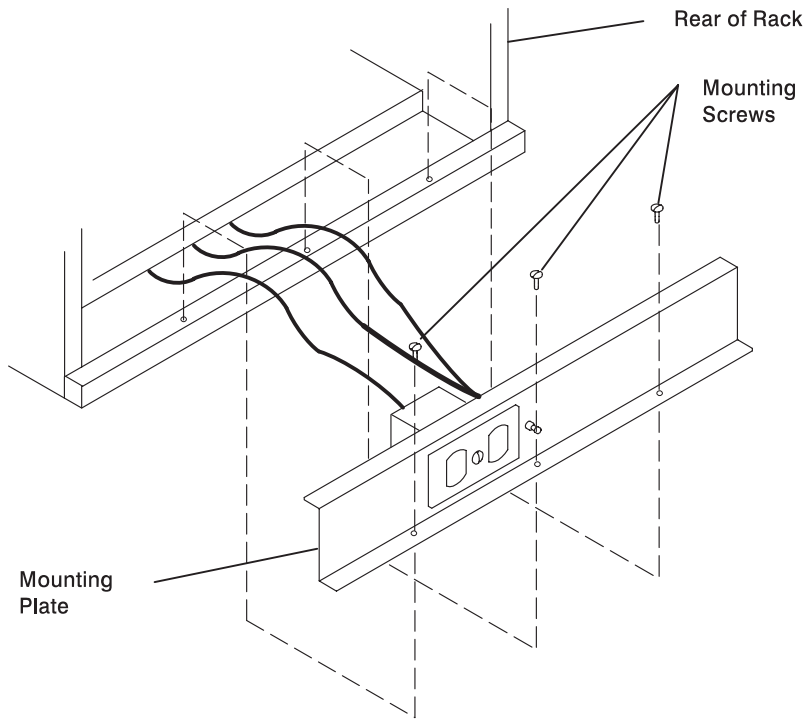

6. Connect the ground connector of the ground cable to the ground bus bar.
7. If a drawer was removed from the bottom position of the rack, reinstall it.
8. Close the rear door of the rack.

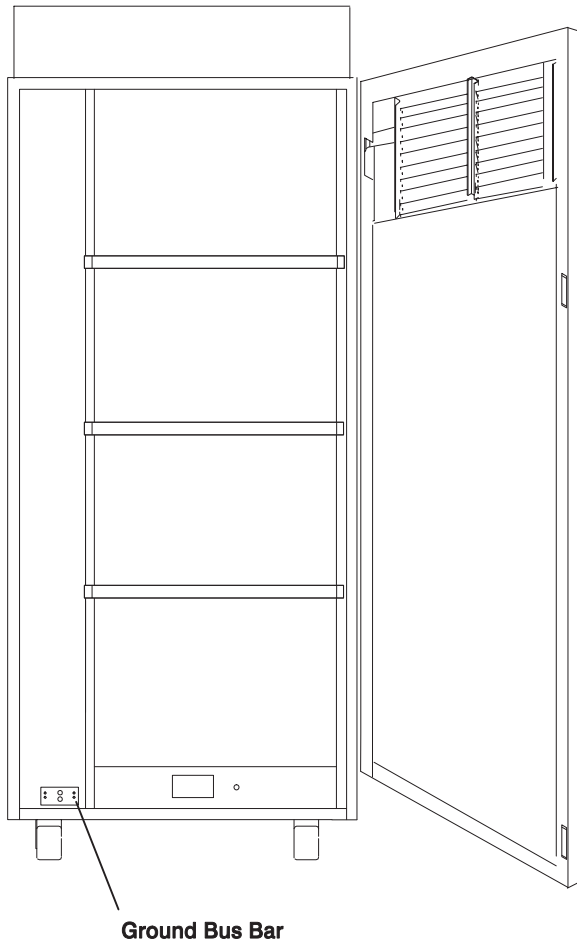

Step 9. Remove the Shipping Brackets and Install Covers

1. Remove any shipping materials from the system rack, I/O racks and from the front and rear of the I/O drawers.
2. Remove the disk drive cover from the front of each I/O drawer. Inspect the disk drives to ensure that the disk-drive carriers are all seated completely and that the carrier latch is in the horizontal locked position.

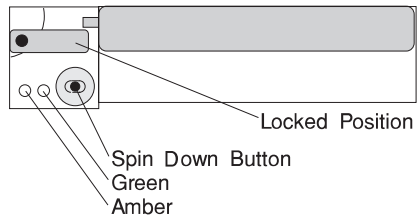

3. Install any covers and shields that you have removed, or that were shipped separately.

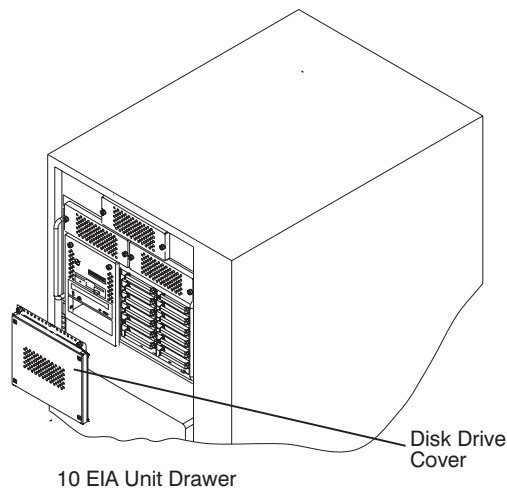

Step 10. Install the I/O Rack Door Guide

1. Locate the I/O rack door guide.
2. Position the door guide as shown.
3. Using a 3mm allen wrench, fasten the door guide to the I/O rack as shown.

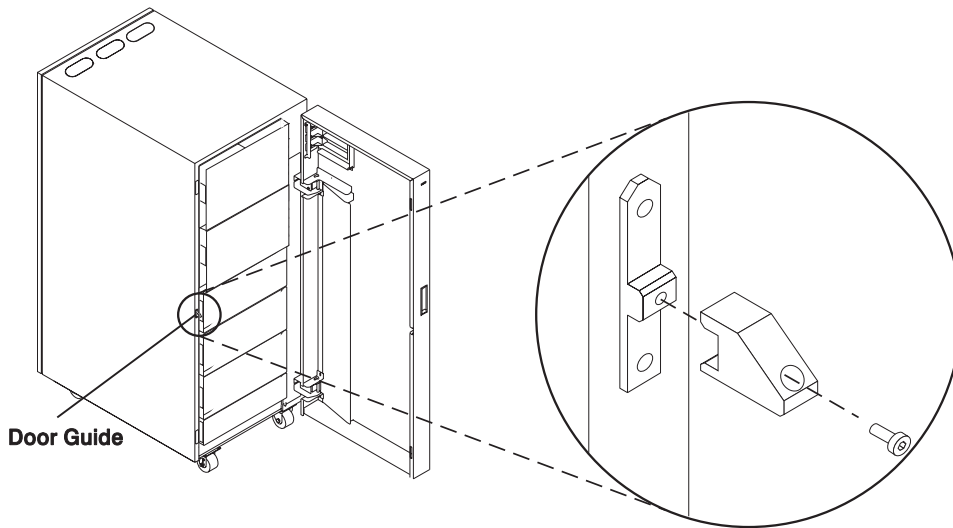

Step 11. Connect the Operator Panel Cable and the JTAG Cable Between the Racks

Using the cables provided, connect the cables between the system rack and the primary I/O drawer. Refer to “Appendix D. Cabling the System Rack and I/O Rack” on page 47 for connector locations for these cables.

Step 12. Connect RIO and SPCN Cables Between the Racks

Using the cables provided, connect the RIO and SPCN cables between the system rack and the I/O drawers. Refer to “Appendix D. Cabling the System Rack and I/O Rack” on page 47 for valid cabling configurations.

Step 13. Set Up Attached Devices

Note: During the setup of each device, connect only the device end of the signal cable. *Do not* connect the device signal cables to the I/O rack now.

Do the setup procedures in the documentation for each device being attached to the I/O rack; then return to “Step 14. Update the Device Records” on page 29.

Connect the ASCII terminal to serial port S1. Connect the keyboard, mouse, and graphics display (if available). Refer to “I/O Drawer Locations” on page 50 for the locations of the connectors.

Step 14. Update the Device Records

External devices used with the S80 and S85 systems are connected to connectors on the primary I/O drawer or to adapters that are installed inside any of the I/O drawers.

Update the “System Records” in “Appendix E. System Records” on page 63 to reflect the configuration of the system adapters and devices that are installed.

Step 15. Attach External Devices

External devices used with the S80 and S85 system are connected to connectors on the primary I/O drawer or to adapters that are installed inside any of the I/O drawers. Refer to “Appendix E. System Records” on page 63 for listings of installed adapters to determine where to attach external devices. Attach any external devices now.

Step 16. Connect the Power

1. Plug the drawer power cords into the power distribution bus (PDB) of the I/O rack.
Attention: If the system has the dual line cord feature, be sure that both power supplies have power cords plugged in.
2. Plug the power cords of the external devices into power outlets.
3. Plug the PDB power cord into the customer’s electrical outlet.
4. Plug the system rack power cord into the customer’s electrical outlet.

Step 17. Power On and Check Out the System

1. If your system is a high-availability system, make sure all power control interface cables (if installed) are disconnected. High-availability systems usually require drawers to remain powered on when the system rack is powered off. If the power control to certain drawers in your system is different from the factory settings, use your planning information and any documentation supplied for the power control system to understand power control.
2. Press the white power button on the operator panel. The operator panel is located inside the front door of the system rack.
3. Go to the chapter titled “Installation Checkout Procedure” in the *Diagnostic Information for Multiple Bus Systems* manual, and follow the procedures there to check out the system.

Note: If the SP system attachment adapter is installed in the system, it will not be recognized until the Parallel System Support Programs (PSSP) software is installed on the system following attachment to the RS/6000 SP system.

Checklist If Problems Occur

If you have a problem when you try to turn on the system power, check to ensure:

- The EPO switch is on
- Rack power cables are installed

- PDB circuit breakers CP1 - CP6 are set correctly (refer to "I/O Rack Rear Locations" on page 49 for locations)
- Customer's supply voltage is correct.

If any failures occur, refer to "Maintenance Analysis Procedures (MAPs)" in the Enterprise Server S80 p Series 680 Model S85 Service Guide, order number SA38-0560.

If you have a problem when you try to IPL the system, do the following:

- Check signal cables
- Check signal cable terminating plugs
- Verify device addresses
- Verify console has power
- Verify cable networks.

If any failures occur, refer to "Maintenance Analysis Procedures (MAPs)" in the Enterprise Server S80 p Series 680 Model S85 Service Guide, order number SA38-0560.

Step 18. Service Processor Setup and Test

Refer to "Service Processor Setup and Test" in the Enterprise Server S80, p Series 680 Model S85 User's Guide, order number SA38-0557, and perform the steps necessary to set up and test the service processor, then return here.

Note: If this system will be attached to an RS/6000 SP system, you only need to modify the "System Name" parameter. See "Privileged User Menus" in the Enterprise Server S80 p Series 680 Model S85 Service Guide, order number SA38-0560.

Step 19. Install the Modem and Electronic Service Agent

If you have not yet installed the modem, do so now (see "Step 15. Attach External Devices" on page 29).

Refer to *Electronic Service Agent for RS/6000 User's Guide*, order number ZA38-0383, and perform the steps necessary to install the Electronic Service Agent for RS/6000, then return here.

Step 20. Finish the Installation

- ___ 1. Record the system identification numbers.
The system has important identification information that may be needed if service is required. Record this information in "Appendix E. System Records" on page 63.
- ___ 2. The Capacity Upgrade on Demand feature may be installed.

If so, see "Capacity Upgrade on Demand Processor Enabling" in *Capacity Upgrade on Demand Installing and Upgrading Processors*, order number SA38-0583, for information regarding installing and enabling this feature.

- ___ 3. If you decided to delay installing any optional devices, you might want to install these now.

Some options you can install may come with a diskette that contains device drivers, configuration files, or test programs. To install these files (after the operating system is installed), follow the instructions provided with the option.

- ___ 4. If this system will be attached to an RS/6000 SP system, continue with procedures in "Installing SP-Attach Server Cables.", "Chapter 2, RS/6000 SP Installation Instructions" in the *RS/6000 SP Maintenance Information Manual, Volume 1, Installation and Customer Engineering Operations* manual, order number GC23-3903.
- ___ 5. To install application programs, follow the instructions supplied with each application program.

If any failures occur, refer to "Maintenance Analysis Procedures (MAPs)" in the Enterprise Server S80 p Series 680 Model S85 Service Guide, order number SA38-0560.

Chapter 2. Using the System Verification Procedure

The system verification procedure is used to check the system for correct operation.

If you are analyzing a hardware problem, see "Hardware Problem Determination" in Enterprise Server S80, p Series 680 Model S85 User's Guide, order number SA38-0557.

Step 1. Considerations before Running This Procedure

Notes:

1. If this system unit is directly attached to another system unit or attached to a network, make sure that communications with the other system unit are stopped.
2. This procedure requires use of all of the system resources. No other activity can be running on the system while you are doing this procedure.
 - This procedure requires a display connected to the video port or an ASCII terminal attached to the S1 port.
 - Before starting this procedure, stop all programs and the operating system.
 - This procedure runs the online diagnostics in service mode or standalone diagnostics. If the online diagnostics are installed, they should be run. See the operator manual for your type of ASCII terminal to find the key sequences you need to respond to the diagnostics.
 - If you need more information about diagnostics, see the Enterprise Server S80, p Series 680 Model S85 User's Guide, order number SA38-0557.
 - If a console display is not selected, the diagnostics stop. The instructions for selecting a console display are displayed on all of the graphic displays and any terminal attached to the S1 port. Follow the instructions to select a console display.
 - Go to Step 2.

Step 2. Loading the Diagnostics

1. Stop all application programs running on the operating system.
2. Stop the operating system.
3. Turn the power off.
4. If you are loading the standalone diagnostics and running them from an ASCII terminal, do the following:
 - The attributes for the terminal must be set to match the defaults of the diagnostics.
 - If you need to change any settings, record the normal settings, and be sure the terminal attributes are set to work with the diagnostics. If needed, see "Running the Diagnostics from a TTY Terminal" in the Enterprise Server S80, p Series 680 Model S85 User's Guide, order number SA38-0557.
 - Proceed to substep 5 when you finish checking the attributes.
5. Turn the power on.

- a. When the keyboard indicator appears, press the 5 key on the keyboard to load the standalone diagnostics or press the 6 key to load the online diagnostics.
 - b. Enter any requested passwords.
 - c. Follow the instructions to select a console.
6. When the Diagnostic Operating Instructions display, go to "Step 3. Running System Verification". If you are unable to load the diagnostics, go to "Problem Determination When Unable to Load Diagnostics" in the Enterprise Server S80, p Series 680 Model S85 User's Guide, order number SA38-0557.

Step 3. Running System Verification

1. On the Diagnostic Operating Instructions screen, press the Enter key.
2. If the terminal type has not been defined, you must use the Initialize Terminal option on the Function Selection menu to initialize the operating system environment before you can continue with the diagnostics.
3. If you want to do a general checkout with minimal operator action, select the Diagnostic Routines option on the Function Selection menu.

If you want to do a more complete checkout including the use of wrap plugs, select the Advanced Diagnostics option on the Function Selection menu. The advanced diagnostics are primarily for the service representative; they may instruct you to install wrap plugs to better isolate a problem.
4. Select the System Verification option on the Diagnostic Mode Selection menu.
5. If you want to run a general checkout of all installed resources, select the All Resource option on the Diagnostic Selection menu.

If you want to check one particular resource, select that resource on the Diagnostic Selection menu.
6. Go to "Step 4. Additional System Verification".

Step 4. Additional System Verification

The checkout programs end with either the Testing Complete menu and a message stating No trouble was found or the A Problem Was Detected On (Time Stamp) menu with an SRN.

1. Press Enter to return to the Diagnostic Selection menu.
2. If you want to check other resources, select the resource. When you have checked all of the resources you need to check, go to "Step 5. Stopping the Diagnostics".

Step 5. Stopping the Diagnostics

1. If you are running online diagnostics, shut down the system, using the following procedure:
 - a. Press the 3 key repeatedly until you get to the Diagnostic Operating Instructions, then follow the displayed instructions.
 - b. Press the 3 key once, and then follow the displayed instructions to shut down the system.
2. If you changed any attributes on your ASCII terminal to run the diagnostics, change the settings back to normal.

3. This completes the system verification. Report the SRN if you received one to the service organization. To do a normal boot, turn off the system unit and wait 30 seconds, and then turn the system power on.

Chapter 3. Installing Options for Your System

There are no customer-installable options for the Enterprise Server S80 or the p Series 680 Model S85.

The Capacity Upgrade On-Demand feature may be installed. See *Capacity Upgrade on Demand Installing and Upgrading Processors*, order number SA38-0583, for information regarding installing and enabling this feature.

Appendix A. Communications Statements

The following statement applies to this product. The statement for other products intended for use with this product appears in their accompanying documentation.

Federal Communications Commission (FCC) Statement

Note: This equipment has been tested and found to comply with the limits for a Class A digital device, pursuant to Part 15 of the FCC Rules. These limits are designed to provide reasonable protection against harmful interference when the equipment is operated in a commercial environment. This equipment generates, uses, and can radiate radio frequency energy and, if not installed and used in accordance with the instruction manual, may cause harmful interference to radio communications. Operation of this equipment in a residential area is likely to cause harmful interference in which case the user will be required to correct the interference at his own expense.

Properly shielded and grounded cables and connectors must be used in order to meet FCC emission limits. Neither the provider nor the manufacturer is responsible for any radio or television interference caused by using other than recommended cables and connectors or by unauthorized changes or modifications to this equipment. Unauthorized changes or modifications could void the user's authority to operate the equipment.

This device complies with Part 15 of the FCC Rules. Operation is subject to the following two conditions: (1) this device may not cause harmful interference, and (2) this device must accept any interference received, including interference that may cause undesired operation.

European Union (EU) Statement

This product is in conformity with the protection requirements of EU Council Directive 89/336/EEC on the approximation of the laws of the Member States relating to electromagnetic compatibility. The manufacturer cannot accept responsibility for any failure to satisfy the protection requirements resulting from a non-recommended modification of the product, including the fitting of option cards supplied by third parties. Consult with your dealer or sales representative for details on your specific hardware.

This product has been tested and found to comply with the limits for Class A Information Technology Equipment according to CISPR 22 / European Standard EN 55022. The limits for Class A equipment were derived for commercial and industrial environments to provide reasonable protection against interference with licensed communication equipment.

Attention: This is a Class A product. In a domestic environment this product may cause radio interference in which case the user may be required to take adequate measures.

International Electrotechnical Commission (IEC) Statement

This product has been designed and built to comply with IEC Standard 950.

United Kingdom Telecommunications Safety Requirements

This equipment is manufactured to the International Safety Standard EN60950 and as such is approved in the UK under the General Approval Number NS/G/1234/J/100003 for indirect connection to the public telecommunication network.

The network adapter interfaces housed within this equipment are approved separately, each one having its own independent approval number. These interface adapters, supplied by the manufacturer, do not use or contain excessive voltages. An excessive voltage is one which exceeds 70.7 V peak ac or 120 V dc. They interface with this equipment using Safe Extra Low Voltages only. In order to maintain the separate (independent) approval of the manufacturer's adapters, it is essential that other optional cards, not supplied by the manufacturer, do not use main voltages or any other excessive voltages. Seek advice from a competent engineer before installing other adapters not supplied by the manufacturer.

Avis de conformité aux normes du ministère des Communications du Canada

Cet appareil numérique de la classe A respecte toutes les exigences du Règlement sur le matériel brouilleur du Canada.

Canadian Department of Communications Compliance Statement

This Class A digital apparatus meets the requirements of the Canadian Interference—Causing Equipment Regulations.

VCCI Statement

この装置は、情報処理装置等電波障害自主規制協議会（VCCI）の基準に基づきクラスA情報技術装置です。この装置を家庭環境で使用すると電波妨害を引き起こすことがあります。この場合には使用者が適切な対策を講ずるよう要求されることがあります。

The following is a summary of the VCCI Japanese statement in the box above.

This is a Class A product based on the standard of the Voluntary Control Council for Interference by Information Technology Equipment (VCCI). If this equipment is used in a domestic environment, radio disturbance may arise. When such trouble occurs, the user may be required to take corrective actions.

Electromagnetic Interference (EMI) Statement - Taiwan

警告使用者:

這是甲類的資訊產品，在居住的環境中使用時，可能會造成射頻干擾，在這種情況下，使用者會被要求採取某些適當的對策。

The following is a summary of the EMI Taiwan statement above.

Warning: This is a Class A product. In a domestic environment this product may cause radio interference in which case the user will be required to take adequate measures.

Radio Protection for Germany

Dieses Gerät ist berechtigt in Übereinstimmung mit Dem deutschen EMVG vom 9.Nov.92 das EG-Konformitätszeichen zu führen.

Der Aussteller der Konformitätserklärung ist die IBM Germany.

Dieses Gerät erfüllt die Bedingungen der EN 55022 Klasse A. Für diese von Geräten gilt folgende Bestimmung nach dem EMVG:

Geräte dürfen an Orten, für die sie nicht ausreichend entstört sind, nur mit besonderer Genehmigung des Bundesministers für Post und Telekommunikation oder des Bundesamtes für Post und Telekommunikation betrieben werden. Die Genehmigung wird erteilt, wenn keine elektromagnetischen Störungen zu erwarten sind.

(Auszug aus dem EMVG vom 9.Nov.92, Para.3, Abs.4)

Hinweis

Dieses Genehmigungsverfahren ist von der Deutschen Bundespost noch nicht veröffentlicht worden.

Appendix B. Environmental Notices

Product Recycling and Disposal

This unit contains materials such as circuit boards and connectors with lead that require special handling and disposal at end of life. Before this unit is disposed of, these materials must be removed and recycled or discarded according to applicable regulations. This manual contains specific information on batteries where applicable. This product may contain nickel-cadmium and/or lithium batteries. The battery(s) must be recycled or disposed of properly. Recycling facilities may not be available in your area. In the United States, IBM has established a collection process for reuse, recycling, or proper disposal of used sealed lead acid, nickel cadmium and nickel metal hydride batteries and battery packs from IBM equipment. For information on proper disposal of the nickel cadmium batteries in this product, please contact IBM at 1-800-426-4333. For information on battery disposal outside the United States, contact your local waste disposal facility.

Environmental Design

The environmental efforts that have gone into the design of this system signify IBM's commitment to improve the quality of its products and processes. Some of these accomplishments include the elimination of the use of Class I ozone-depleting chemicals in the manufacturing process and reductions in manufacturing wastes. For more information, contact an IBM account representative.

Unit Emissions

The unit-related emission value is equal to or lower than 70dB(A).

Der Geräuschpegel der Einheit ist kleiner oder gleich 70 db(A).

Appendix C. Notices

This information was developed for products and services offered in the U.S.A.

The manufacturer may not offer the products, services, or features discussed in this document in other countries. Consult the manufacturer's representative for information on the products and services currently available in your area. Any reference to the manufacturer's product, program, or service is not intended to state or imply that only that product, program, or service may be used. Any functionally equivalent product, program, or service that does not infringe any intellectual property right of the manufacturer may be used instead. However, it is the user's responsibility to evaluate and verify the operation of any product, program, or service.

The manufacturer may have patents or pending patent applications covering subject matter described in this document. The furnishing of this document does not give you any license to these patents. You can send license inquiries, in writing, to the manufacturer.

The following paragraph does not apply to the United Kingdom or any country where such provisions are inconsistent with local law: THIS MANUAL IS PROVIDED "AS IS" WITHOUT WARRANTY OF ANY KIND, EITHER EXPRESSED OR IMPLIED, INCLUDING, BUT NOT LIMITED TO, THE IMPLIED WARRANTIES OF NON-INFRINGEMENT, MERCHANTABILITY OR FITNESS FOR A PARTICULAR PURPOSE. Some states do not allow disclaimer of express or implied warranties in certain transactions; therefore, this statement may not apply to you.

This information could include technical inaccuracies or typographical errors. Changes are periodically made to the information herein; these changes will be incorporated in new editions of the publication. The manufacturer may make improvements and/or changes in the product(s) and/or the program(s) described in this publication at any time without notice.

Information concerning products made by other than the manufacturer was obtained from the suppliers of those products, their published announcements, or other publicly available sources. The manufacturer has not tested those products and cannot confirm the accuracy of performance, compatibility or any other claims related to products made by other than the manufacturer. Questions on the capabilities of products made by other than the manufacturer should be addressed to the suppliers of those products.

Appendix D. Cabling the System Rack and I/O Rack

The minimum system consists of two racks. The system rack contains the system processors, memory and supporting hardware. The I/O rack contains I/O drawer(s) with PCI adapters, disk drives, and media drives. The S80 and S85 must have a minimum of one I/O drawer. This drawer is called the primary I/O drawer and it contains the service processor for the system. Additional I/O drawers can be added to the system. These drawers are called secondary I/O drawers. Secondary I/O drawers are connected to the system rack but do not contain a service processor. The S80 and S85 support up to a total of four I/O drawers in various I/O rack configurations.

There are two steps to connecting the system rack to the I/O drawers in their I/O racks.

1. Connect the JTAG cable and the operator panel cable. These two cables are connected only between the system rack and the primary I/O drawer. See “Connecting JTAG and Operator Panel Cables” on page 48 for diagrams showing these cables.
2. Connect the RIO cables and the SPCN cables. These cables connect between the system rack and all the I/O drawers in loops. See “Connecting RIO and SPCN Cables” on page 57 for diagrams showing these cables.

Connecting JTAG and Operator Panel Cables

Use the following figure to connect the JTAG and operator panel (OP) cables.

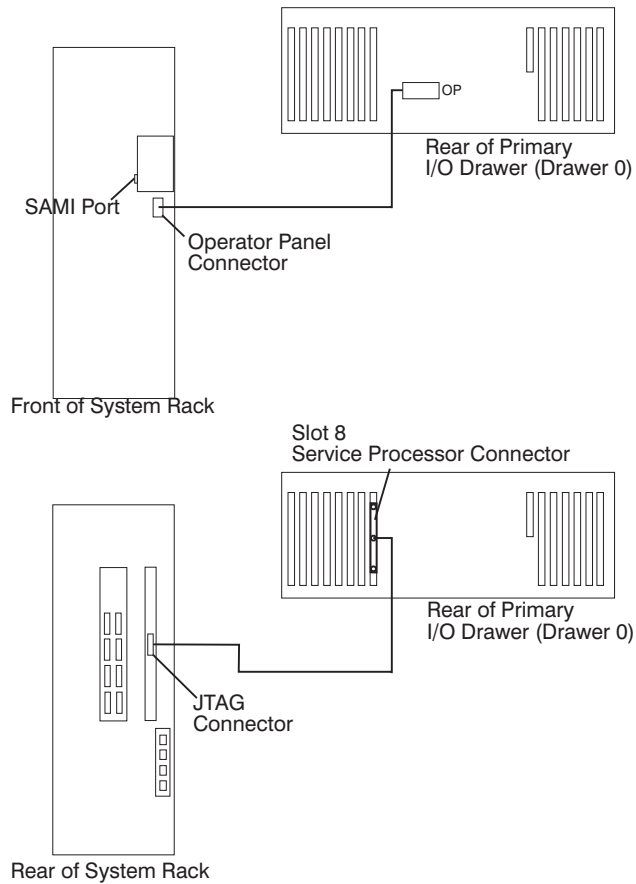

I/O Rack Rear Locations

The following figure shows the rear of an I/O rack. 10 EIA unit I/O drawers can be installed, as shown in the figure.

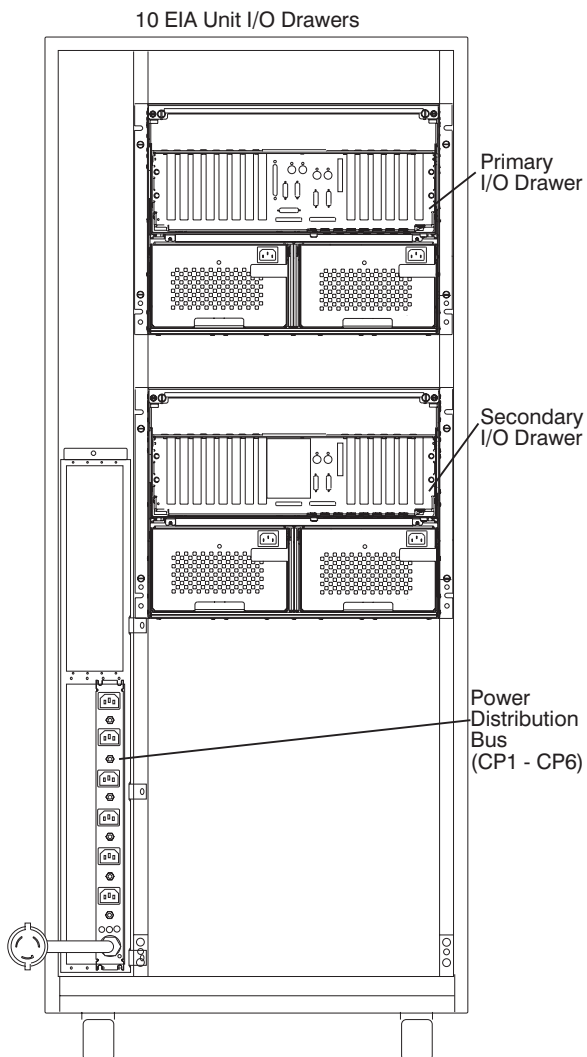

I/O Drawer Locations

This section shows component locations for the 10 EIA unit I/O drawer.

10 EIA Unit I/O Drawer Front View

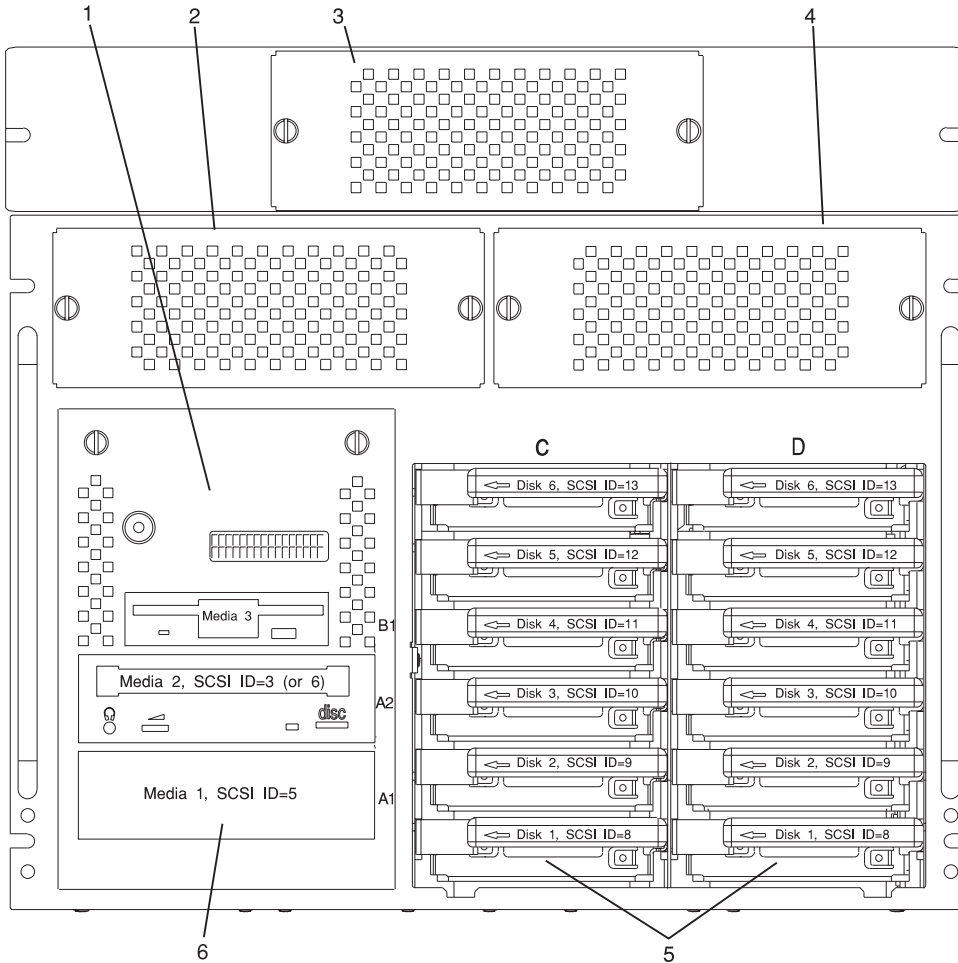

Note: The SCSI IDs shown for media devices indicate how these devices are set when shipped from the factory.

1. Indicator Panel
2. Blower 1 (left)
3. Blower 3 (center)
4. Blower 2 (right)
5. Hot Swap Disk Drive Bays
6. Media Bay

10 EIA Unit I/O Drawer Rear View

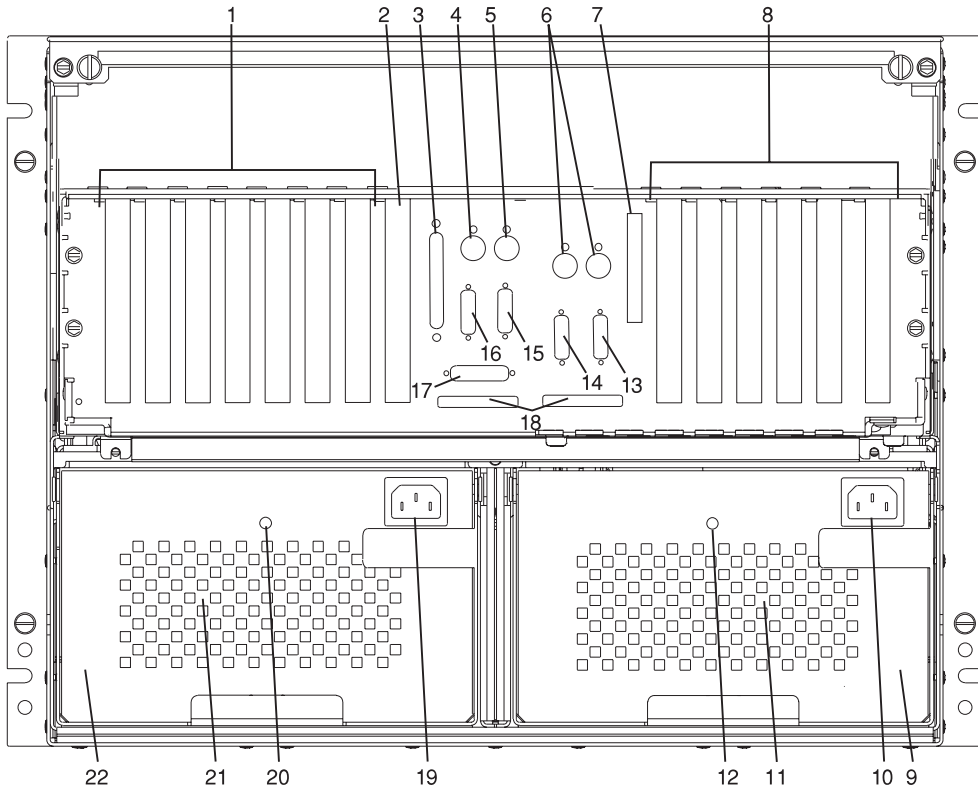

1. PCI adapter slots (1 - 7)
2. PCI adapter slot 8, service processor card and JTAG cable in primary I/O drawer (drawer 0)
3. Parallel connector
4. Keyboard connector
5. Mouse connector
6. Reserved
7. Reserved
8. PCI adapter slots (9 - 14)
9. Right power supply
10. Power cord connector for right power supply
11. Fans (mounted on front end of right power supply)
12. Right power supply, power good LED
13. SPCN2 connector
14. SPCN1 connector
15. Serial port S2*
16. Serial port S1* (Used for TTY terminal connection)

Note: In an RS/6000 SP environment, there is normally a cable attached from this port to the SP Control Workstation. To directly attach a TTY terminal to this port, the cable to the SP Control Workstation must be disconnected. Be sure to reconnect this cable after servicing the system.

17. Operator panel (OP) connector
18. RIO 0 and RIO 1
19. Power cord connector for left power supply
20. Left power supply, power good LED
21. Fans (mounted on front end of left power supply)
22. Left power supply

* Serial ports 1 and 2 can only be used for service processor menus. No "heartbeat" type devices can be used on these ports.

10 EIA Unit I/O Drawer System board Locations

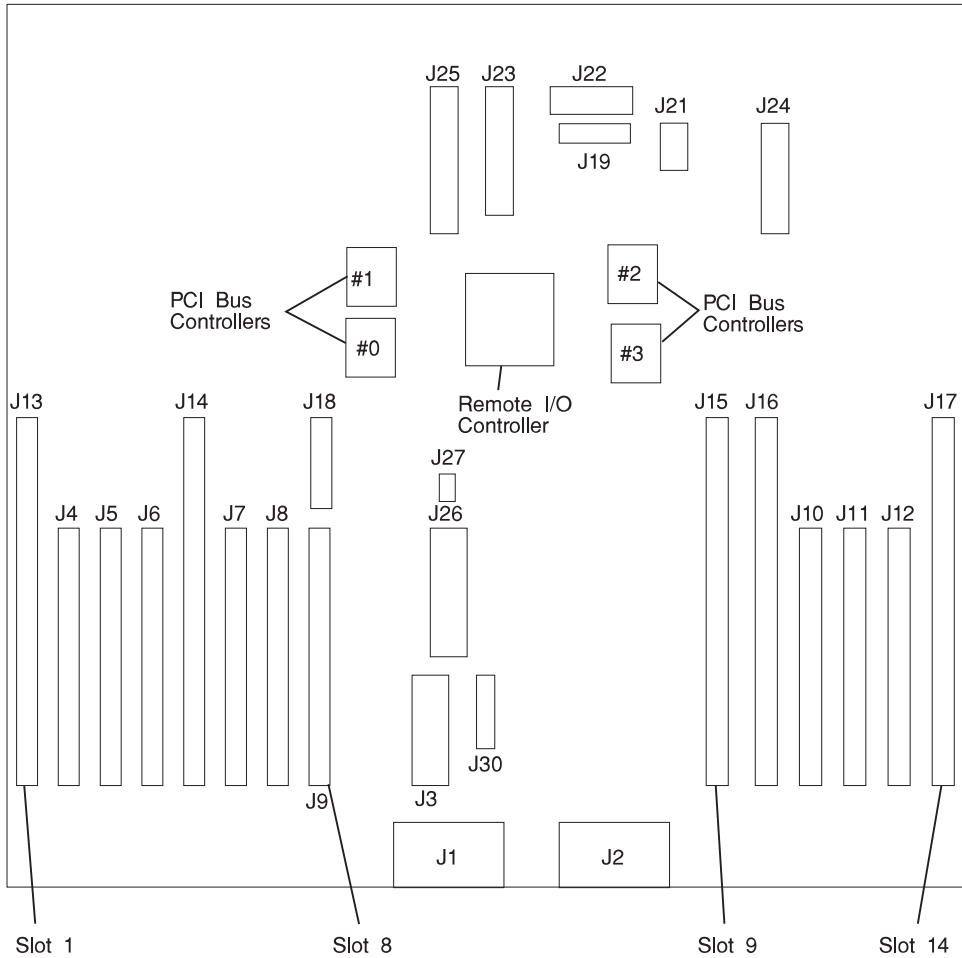

- J1** RIO bus
- J2** RIO bus
- J3** SPCN connector
- J4** PCI slot 2, controller 1
- J5** PCI slot 3, controller 1
- J6** PCI slot 4, controller 1
- J7** PCI slot 6, controller 0
- J8** PCI slot 7, controller 0
- J9** PCI slot 8, controller 0

J10	PCI slot 11, controller 2
J11	PCI slot 12, controller 2
J12	PCI slot 13, controller 2
J13	PCI slot 1, controller 1
J14	PCI slot 5, controller 0
J15	PCI slot 9, controller 3
J16	PCI slot 10, controller 3
J17	PCI slot 14, controller 2
J18	JTAG connector
J19	Display indicator panel (DIP) connector
J21	I35 SCSI backplane connector
J22	Power distribution board (PDB) card connector
J23	PCI slot (1-8) power connector
J24	PCI slot (9-14) power connector
J25	+12 vdc, -12 vdc, and +3.3 vdc, power supply connector
J26	PCI slot power (1-8) +3.3 vdc power connector
J27	Speaker
J30	Reserved

Service Processor Card Locations

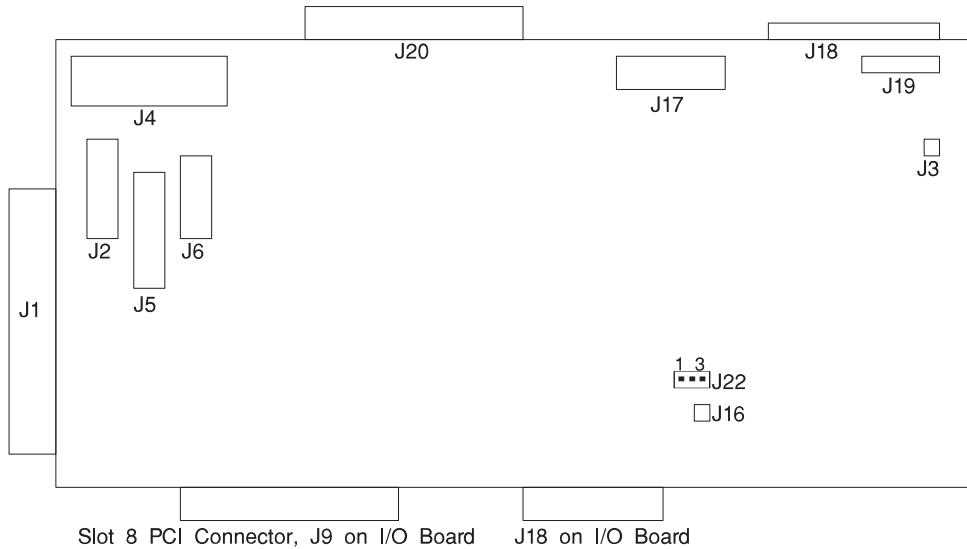

- | | |
|------------|--|
| J1 | JTAG connector to system rack |
| J2 | Serial port connector to inside bulkhead card |
| J3 | Speaker connector |
| J4 | Diskette drive connector |
| J5 | Parallel port connector |
| J6 | Keyboard/mouse connector to inside bulkhead card |
| J16 | Write protect DASD FLASH (if jumper is on pins) |
| J17 | Operator panel connector from the system rack |
| J18 | Test Port 0 |
| J19 | Test Port 1 |
| J20 | Test Port 2 |
| J22 | Write protect boot FLASH (if jumper is set between pins 2 and 3) |

Fan Monitor Control (FMC) Card Locations (10 EIA Unit I/O Drawer)

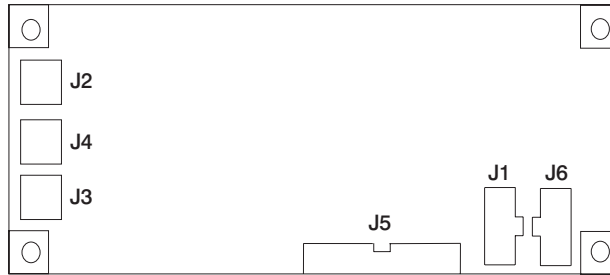

- J1** To Power Distribution Board
- J2** Fan 2 (Left Blower)
- J3** Fan 1 (Center Blower)
- J4** Fan 3 (Right Blower)
- J5** Power Supply and Fans 4, 5, 6, 7 (Power Supply Fan Assemblies)
- J6** To PCI Connectors

Power Distribution Board Locations

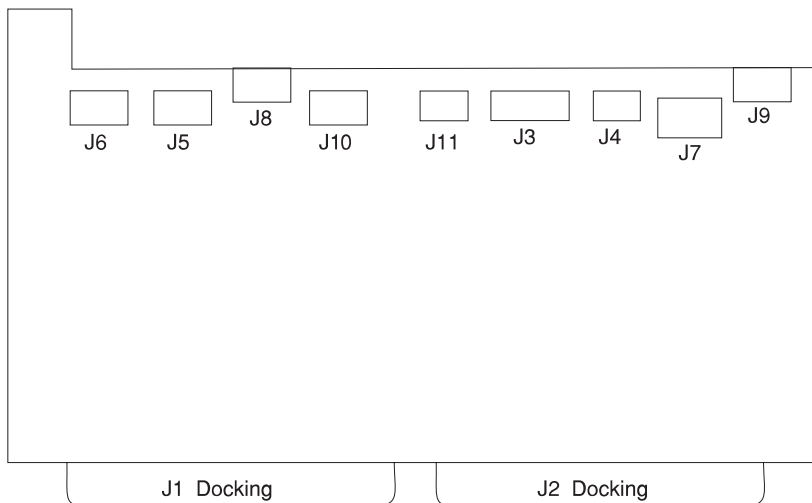

- J1** Power supply docking connector
- J2** Power supply docking connector
- J3** I/O planar connector
- J4** Fan monitoring card connector

J5	+12 V dc, -12 V dc
J6	+5 V dc
J7	+5 V dc
J8	I35 SCSI backplane power connector
J9	Media bay power connector
J10	+5 V dc
J11	Fan monitoring card connector

Connecting RIO and SPCN Cables

The RIO and SPCN cables provide two functions in the S80 and S85 system: remote data bus connection and power control. The following basic rules must be followed when connecting these two types of cables:

- The I/O drawers must be connected in a loop fashion for both the RIO cables and the SPCN cables. The loop connection provides redundant paths so that if a failure occurs in part of a cable, the system will continue to operate. If a failure occurs, a warning message is displayed on the system console but the system continues to operate.
- One loop is required for the SPCN cabling. This loop begins and ends at the system rack.
- Two loops are possible for the RIO cabling depending on the number and desired configuration of I/O drawers. These loops begin and end at the system rack.

RIO Cabling

The following rules apply to RIO cable connections:

- I/O drawers 0 and 1 are connected using the first RIO loop, which uses RIO ports 0 and 1 on the system rack.
- I/O drawers 2 and 3 are connected using the second RIO loop, which uses RIO ports 2 and 3 on the system rack.
- The primary I/O drawer must be installed and connected to RIO port 0 of the system rack. The connection must be made from RIO port 0 of the system rack to RIO port 0 of the primary I/O drawer. This connection is required to make the primary drawer the first drawer in the loop, which allows the firmware to initialize the system.
- If the loop connection between RIO 2 and RIO 3 is broken, the system is not able to differentiate between I/O drawer 2 and I/O drawer 3. The system still configures RIO 0 and RIO 1 ports, but does not configure RIO 2 or RIO 3 ports.

The following figures provide cabling examples of all valid cabling configurations. Match your configuration to the correct figure and connect your RIO cables as shown.

System Rack Attached to One I/O Drawer

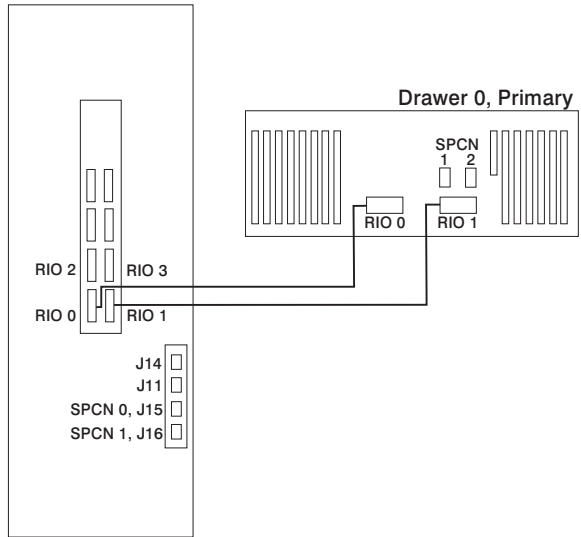

System Rack Attached to Two I/O Drawers

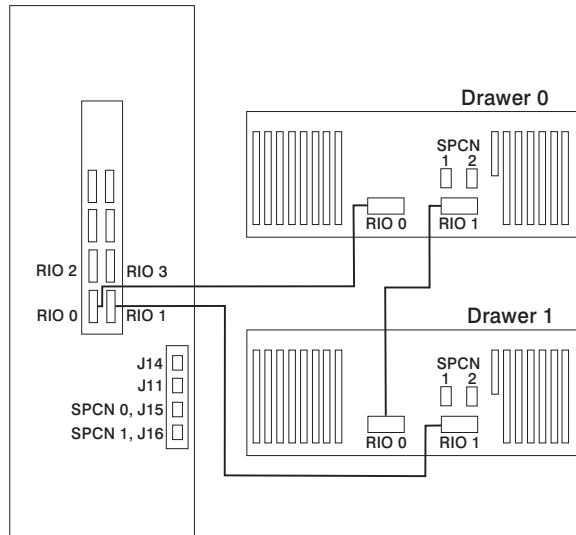

OR

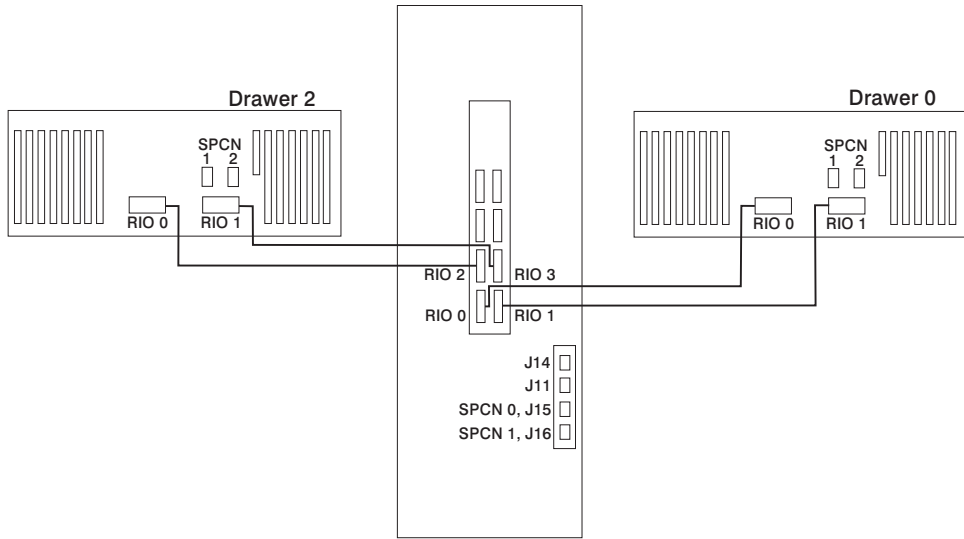

System Rack Attached to Three I/O Drawers

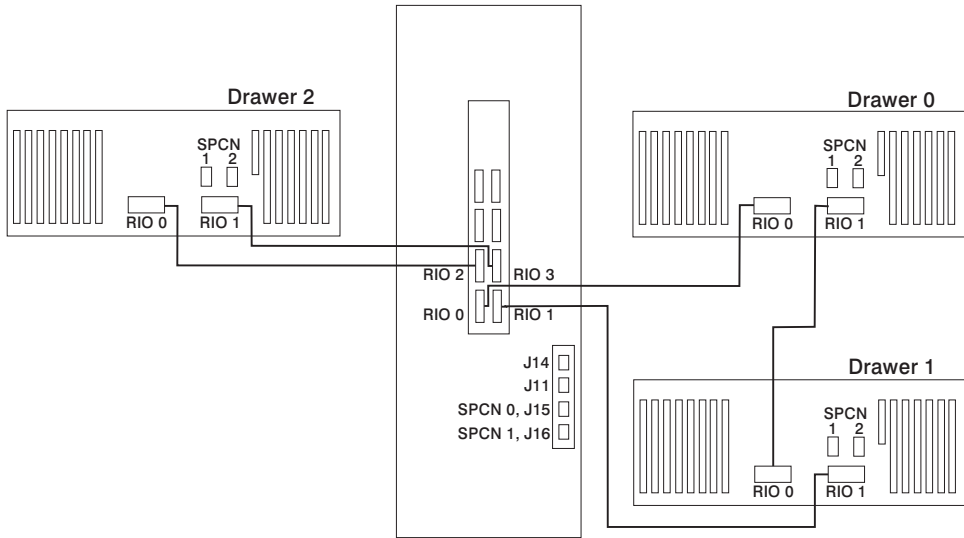

System Rack Attached to Four I/O Drawers

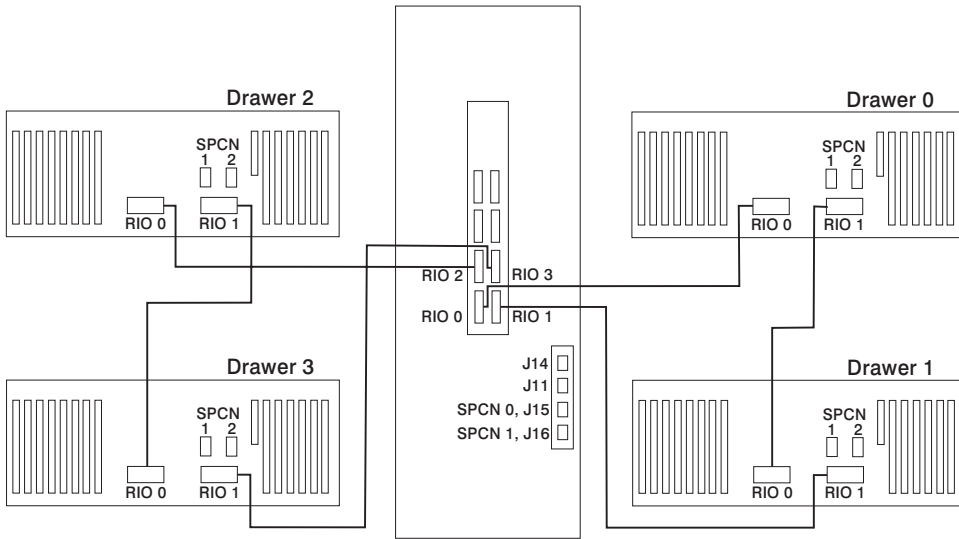

SPCN Cabling

The following figures provide cabling examples for all valid cabling configurations. Match your configuration to the correct figure and connect your SPCN cables as shown.

System Rack Attached to One I/O Drawer

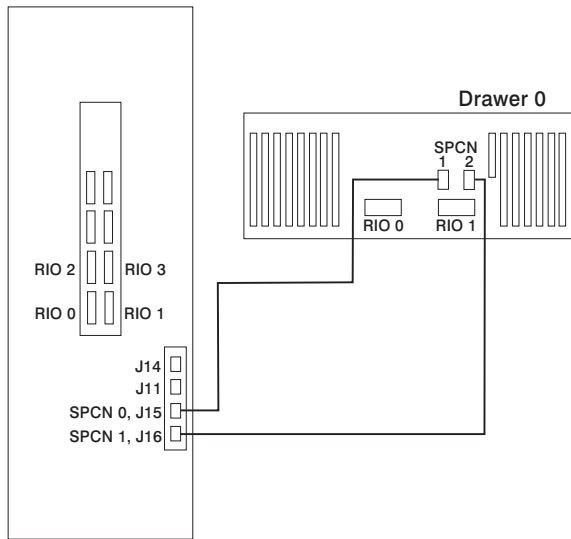

System Rack Attached to Two I/O Drawers

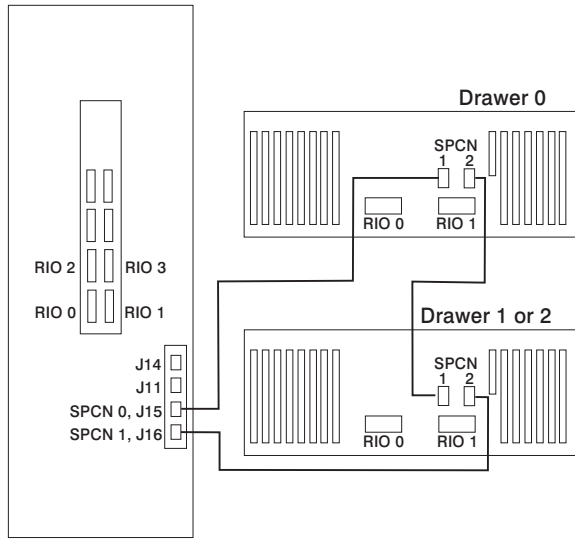

System Rack Attached to Three I/O Drawers

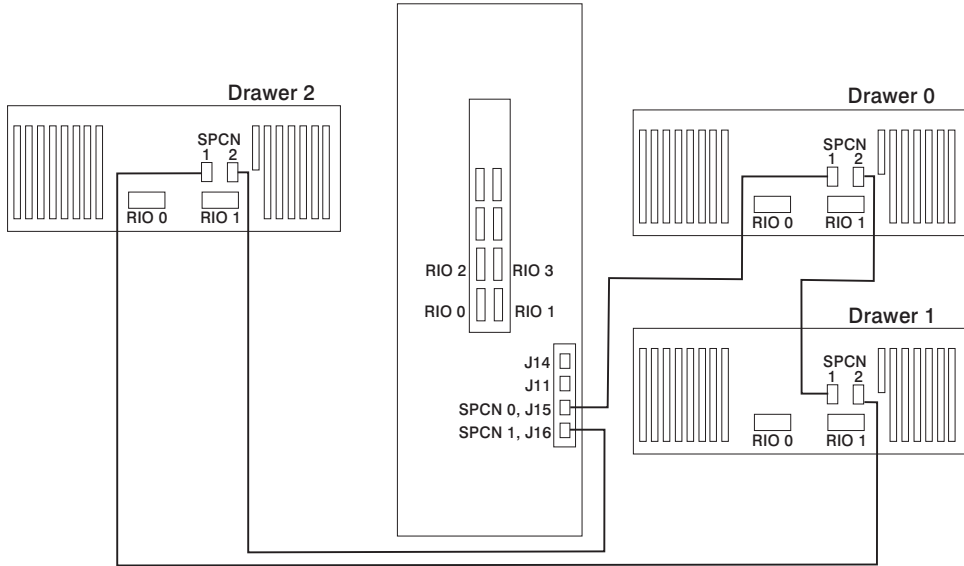

System Rack Attached to Four I/O Drawers

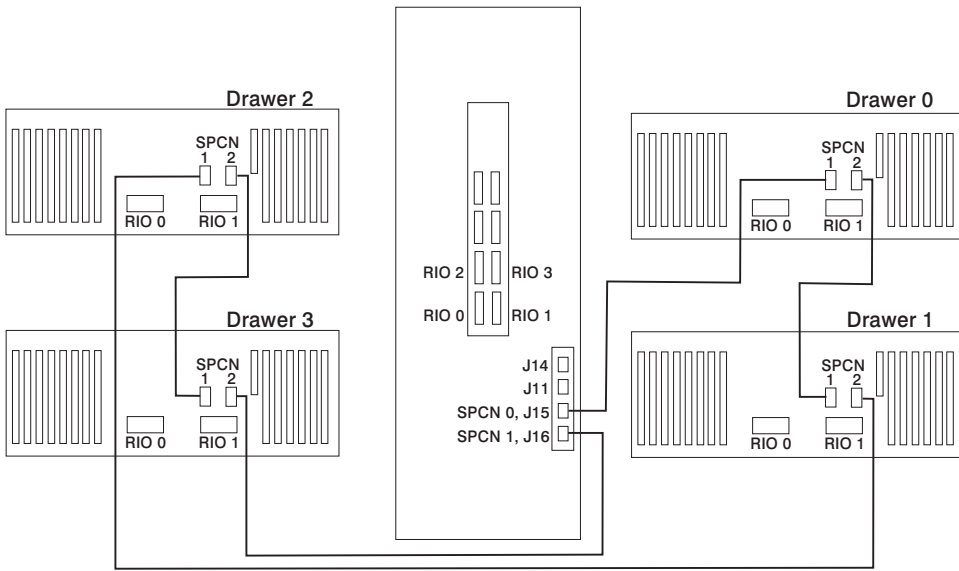

Appendix E. System Records

Use this appendix to keep a record of your system configuration. Pages are provided for system information, cabling diagrams, I/O cards installed, and disk drives installed.

Record the Identification Numbers

Record and retain the following information.

S80 and S85 System Rack

Product Name	S80 and S85 System Rack
Processor Card Slots Installed	
Serial Number	

S80 and S85 System Rack Memory Configuration

Memory Quad	Slots	Memory Card Size
Quad A	M1, M2 M03, M24	
Quad B	M8, M9 M10, M11	
Quad C	M12, M13 M14, M15	
Quad D	M20, M21 M22, M23	

S80 and S85 System Rack Cabling Configurations - RIO Cabling

Use the following diagram to record the RIO cabling configuration from the system rack to the I/O drawer(s).

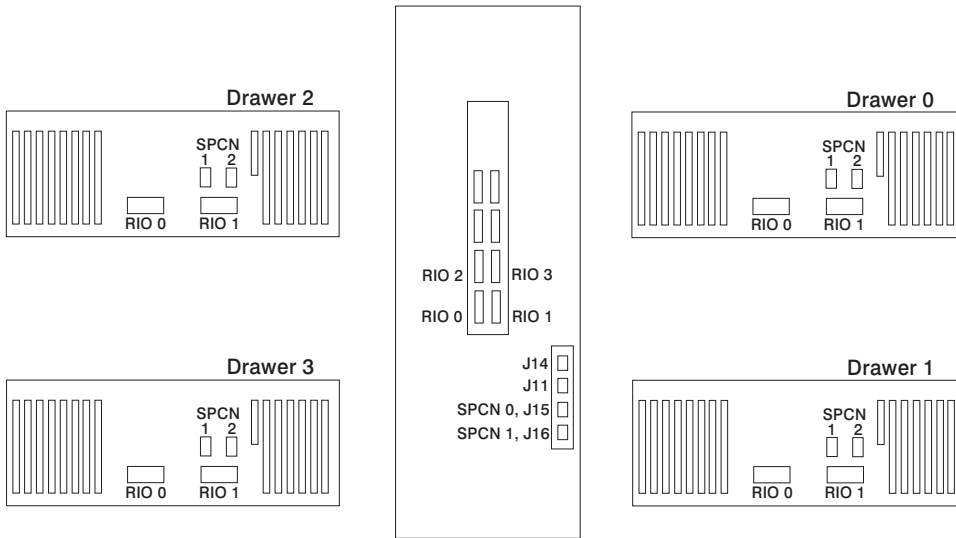

S80 and S85 System Rack Cabling Configurations - SPCN Cabling

Use the following diagram to record the SPCN cabling configuration from the system rack to the I/O drawer(s).

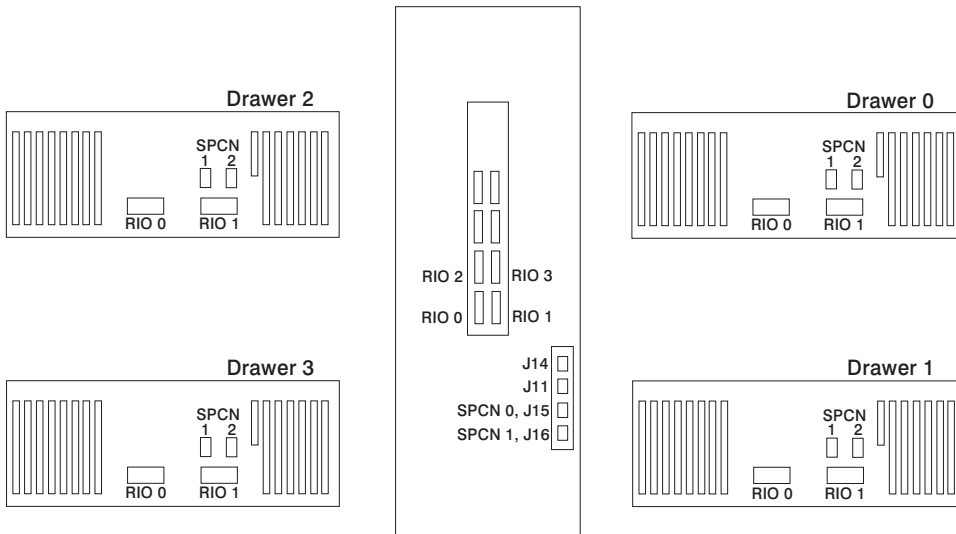

Primary I/O Drawer Device Records

Use the following tables to keep a record of the options installed in or attached to your system. This information can be helpful to you or your service representative when you install additional options in your server.

Table 1. Internal and External Options in Primary Drawer (0)

Location	Option Description
Mouse Connector	<u>Mouse</u> <input type="checkbox"/> Other: _____
Keyboard Connector	<u>Space Saving</u> <input type="checkbox"/> <u>Enhanced</u> <input type="checkbox"/> Other: _____
Expansion Slot 14	
Expansion Slot 13	
Expansion Slot 12	
Expansion Slot 11	
Expansion Slot 10	
Expansion Slot 9	
Expansion Slot 8	RESERVED - Service Processor
Expansion Slot 7	
Expansion Slot 6	
Expansion Slot 5	
Expansion Slot 4	
Expansion Slot 3	
Expansion Slot 2	
Expansion Slot 1	
Parallel Port	
Serial Port 1	

Table 1. Internal and External Options in Primary Drawer (0) (continued)

Serial Port 2

Refer to the following diagram of your server's banks/bays when completing Table 2.

10 EIA Unit I/O Drawer

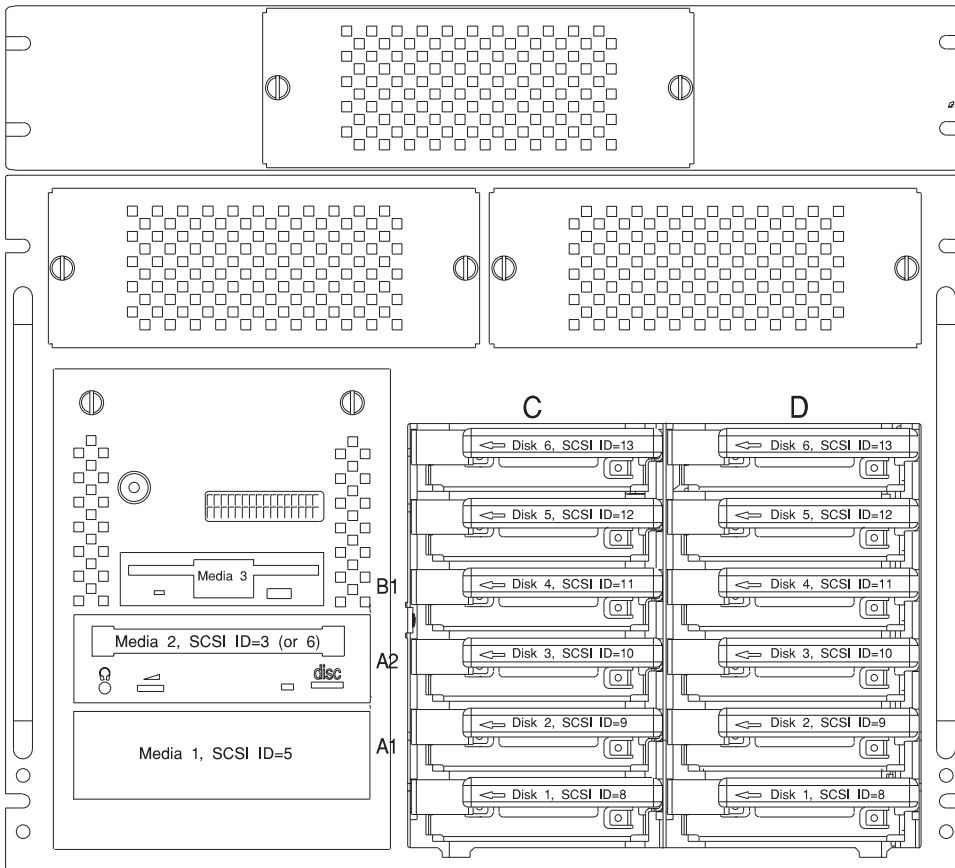

Table 2. Internal Files and Devices in Primary Drawer (0) 10 EIA Unit I/O Drawer

Location/Drive	SCSI ID	Drive Description
Bank B, Bay 1	Non-SCSI	<u>3.5-Inch 1.44MB Diskette Drive</u>
Bank A, Bay 2	3	<u>CD-ROM Drive</u>

Table 2. Internal Files and Devices in Primary Drawer (0) 10 EIA Unit I/O Drawer (continued)

Location/Drive	SCSI ID	Drive Description
Bank A, Bay 1	5	
Bank C, Drive 1	8	
Bank C, Drive 2	9	
Bank C, Drive 3	10	
Bank C, Drive 4	11	
Bank C, Drive 5	12	
Bank C, Drive 6	13	
Bank D, Drive 1	8	
Bank D, Drive 2	9	
Bank D, Drive 3	10	
Bank D, Drive 4	11	
Bank D, Drive 5	12	
Bank D, Drive 6	13	

Additional I/O Drawer Device Records

Use the following tables to keep a record of the options installed in or attached to your system. This information can be helpful to you or your service representative when you install additional options in your server.

Table 3. Internal and External Options in Secondary Drawer (1)

Location	Option Description / Drawer # Description
Expansion Slot 14	
Expansion Slot 13	
Expansion Slot 12	
Expansion Slot 11	
Expansion Slot 10	
Expansion Slot 9	
Expansion Slot 8	
Expansion Slot 7	
Expansion Slot 6	
Expansion Slot 5	
Expansion Slot 4	
Expansion Slot 3	
Expansion Slot 2	
Expansion Slot 1	

Table 4. Internal and External Options in Secondary Drawer (2)

Location	Option Description / Drawer # Description
-----------------	--

Table 4. Internal and External Options in Secondary Drawer (2) (continued)

Expansion Slot 14
Expansion Slot 13
Expansion Slot 12
Expansion Slot 11
Expansion Slot 10
Expansion Slot 9
Expansion Slot 8
Expansion Slot 7
Expansion Slot 6
Expansion Slot 5
Expansion Slot 4
Expansion Slot 3
Expansion Slot 2
Expansion Slot 1

Table 5. Internal and External Options in Secondary Drawer (3)

Location	Option Description / Drawer # Description
Expansion Slot 14	
Expansion Slot 13	
Expansion Slot 12	
Expansion Slot 11	

Table 5. Internal and External Options in Secondary Drawer (3) (continued)

Expansion Slot 10
Expansion Slot 9
Expansion Slot 8
Expansion Slot 7
Expansion Slot 6
Expansion Slot 5
Expansion Slot 4
Expansion Slot 3
Expansion Slot 2
Expansion Slot 1

Index

A

about this book ix

B

battery
disposal, recycling 43

C

cables
JTAG 48
operator panel 48
RIO 57
SPCN 57, 60
cabling 47
connecting cables 47
connecting the system rack and I/O rack 47

D

device records 65, 68
internal and external options 65, 68
internal files and devices 66

F

fan monitor control card 56
FMC card 56

I

installation, system 1
installing cables 47

J

JTAG connection 48

L

laser vi
laser compliance statement vi
laser compliance statement vi
laser safety information vi
locations
10 EIA unit I/O drawer front 50
I/O Drawer rear 51
I/O rack rear 49
service processor card 55

M

memory configuration records 63

N

notices vi

O

online publications ix
operator panel, cable connection 48

P

preface ix
product disposal 43
publications, online ix

R

records, device 65, 68
recycling 43
related publications ix
RIO cabling configurations 63

S

safety notices v
laser compliance statement vi
service processor card locations 55
SPCN cabling 60
SPCN cabling configurations 64
system installation 1
system records 63
cabling configurations, RIO 63
cabling configurations, SPCN 64
key serial number 63
machine type/model 63
memory configuration 63
serial number 63
system verification procedure 33

T

trademarks x

U

using
system verification procedure 33

Reader's Comments — We'd Like to Hear From You

Title: Enterprise Server S80 p Series 680 Model S85 Installation Guide

Order Number: 09P1686

Overall how satisfied are you with the information in this book?

	Very Satisfied	Satisfied	Neutral	Dissatisfied	Very Dissatisfied
Overall Satisfaction	<input type="checkbox"/>	<input type="checkbox"/>	<input type="checkbox"/>	<input type="checkbox"/>	<input type="checkbox"/>

How satisfied are you that the information in this book is:

	Very Satisfied	Satisfied	Neutral	Dissatisfied	Very Dissatisfied
Accurate	<input type="checkbox"/>	<input type="checkbox"/>	<input type="checkbox"/>	<input type="checkbox"/>	<input type="checkbox"/>
Complete	<input type="checkbox"/>	<input type="checkbox"/>	<input type="checkbox"/>	<input type="checkbox"/>	<input type="checkbox"/>
Easy to find	<input type="checkbox"/>	<input type="checkbox"/>	<input type="checkbox"/>	<input type="checkbox"/>	<input type="checkbox"/>
Easy to understand	<input type="checkbox"/>	<input type="checkbox"/>	<input type="checkbox"/>	<input type="checkbox"/>	<input type="checkbox"/>
Well organized	<input type="checkbox"/>	<input type="checkbox"/>	<input type="checkbox"/>	<input type="checkbox"/>	<input type="checkbox"/>
Applicable to your tasks	<input type="checkbox"/>	<input type="checkbox"/>	<input type="checkbox"/>	<input type="checkbox"/>	<input type="checkbox"/>

Please tell us how we can improve this book:

Thank you for your response. May we contact you? Yes No

When you send comments to us, you grant us a nonexclusive right to use or distribute your comments in any way we believe appropriate without incurring any obligation to you.

Name

Address

Company or Organization

Phone Number

Cut or Fold
Along Line

Fold and Tape

Please do not Staple

Fold and Tape



NO POSTAGE
NECESSARY
IF MAILED IN THE
UNITED STATES

BUSINESS REPLY MAIL



POSTAGE WILL BE PAID BY ADDRESSEE

Information Development
Department H6DS-9561
11400 Burnet Road
Austin, TX 78758-3493



Fold and Tape

Please do not Staple

Fold and Tape

Cut or Fold
Along Line



Part Number: 09P1686



Printed in the United States of America
on recycled paper containing 10%
recovered post-consumer fiber.

November 2000

SA38-0582-00



(1P) P/N: 09P1686

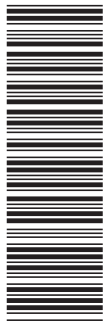

Free Manuals Download Website

<http://myh66.com>

<http://usermanuals.us>

<http://www.somanuals.com>

<http://www.4manuals.cc>

<http://www.manual-lib.com>

<http://www.404manual.com>

<http://www.luxmanual.com>

<http://aubethermostatmanual.com>

Golf course search by state

<http://golfingnear.com>

Email search by domain

<http://emailbydomain.com>

Auto manuals search

<http://auto.somanuals.com>

TV manuals search

<http://tv.somanuals.com>