

# Implementing IBM Tivoli Remote Control Across Firewalls

Achieve Remote Control without  
sacrificing security

Guide for TCP/IP ports used and  
troubleshooting

Set up a secure Remote  
Control environment  
based on realistic  
scenarios

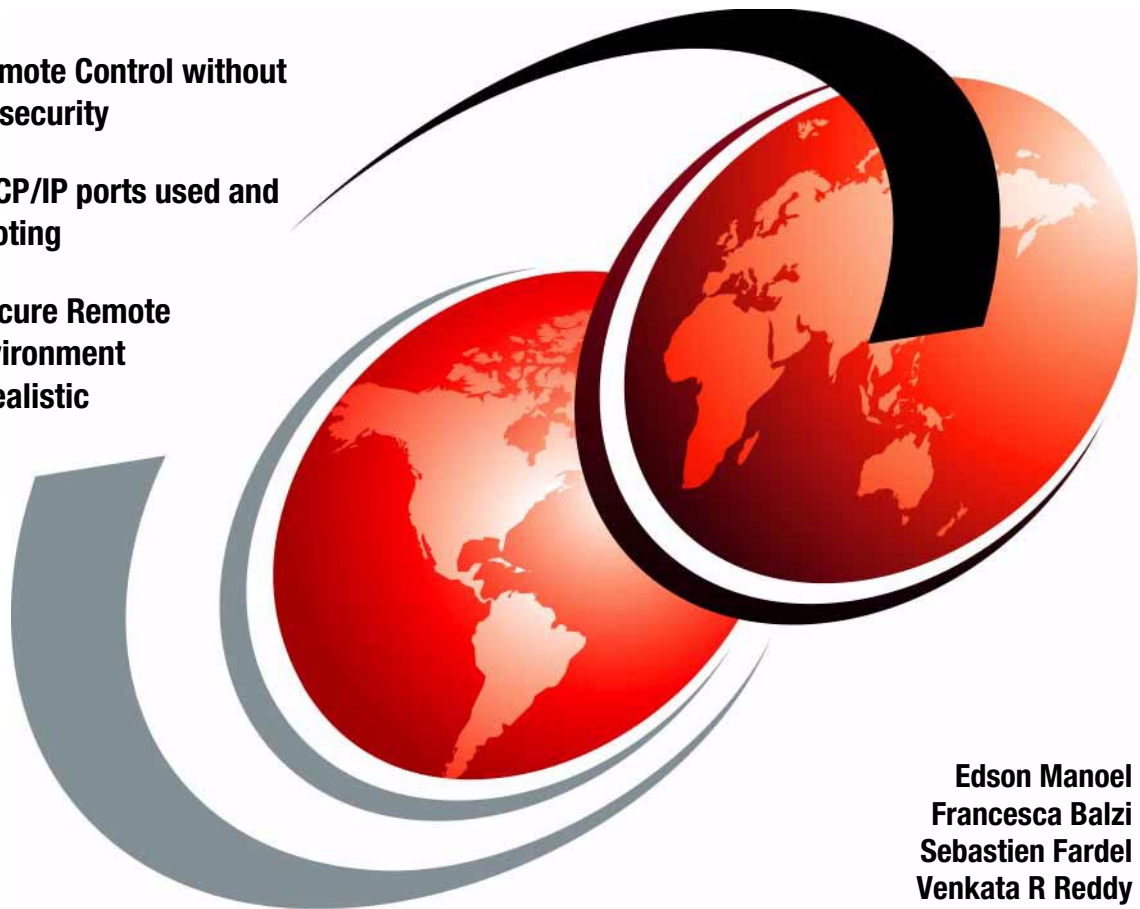

Edson Manoel  
Francesca Balzi  
Sebastien Fardel  
Venkata R Reddy





International Technical Support Organization

**Implementing IBM Tivoli Remote Control Across  
Firewalls**

April 2003

**Note:** Before using this information and the product it supports, read the information in “Notices” on page xiii.

**First Edition (April 2003)**

This edition applies to the following products: IBM Tivoli Remote Control 3.8, IBM Tivoli Management Framework 4.1, and Tivoli Firewall Security Toolbox 1.3.

**© Copyright International Business Machines Corporation 2003. All rights reserved.**

Note to U.S. Government Users Restricted Rights -- Use, duplication or disclosure restricted by GSA ADP Schedule Contract with IBM Corp.

# Contents

<b>Figures</b> .....	vii
<b>Tables</b> .....	ix
<b>Examples</b> .....	xi
<b>Notices</b> .....	xiii
Trademarks .....	xiv
<b>Preface</b> .....	xv
The team that wrote this redbook .....	xv
Become a published author .....	xvi
Comments welcome .....	xvii
<b>Part 1. Concepts and planning</b> .....	1
<b>Chapter 1. Remote Control sessions overview</b> .....	3
1.1 IBM Tivoli Remote Control overview .....	4
1.1.1 IBM Tivoli Management Framework components .....	4
1.1.2 IBM Tivoli Remote Control components .....	7
1.1.3 Tivoli components and communication symbols .....	8
1.1.4 Parent-Child concept .....	10
1.1.5 Proxy connection types .....	11
1.2 IBM Tivoli Remote Control sessions overview .....	12
1.2.1 Session in a single-TMR environment .....	14
1.2.2 Session in a multi-TMR environment .....	21
1.2.3 Session using a Remote Control Gateway .....	31
1.2.4 Session using Remote Control Proxies Standalone .....	35
1.2.5 Session using Remote Control Proxies in a TFST environment .....	45
<b>Chapter 2. Implementation planning</b> .....	57
2.1 Design .....	58
2.1.1 Logical design .....	58
2.1.2 Physical design .....	59
2.1.3 Network considerations .....	61
2.2 Planning for IBM Tivoli Remote Control Proxy .....	73
2.3 Implementation planning case study scenario .....	80
<b>Part 2. Implementation scenarios</b> .....	91

<b>Chapter 3. Implementation scenario: Standalone Proxies</b>	93
3.1 Scenario overview	94
3.2 Environment description	94
3.2.1 Technical infrastructure	95
3.2.2 Data flow description	99
3.3 Scenario installation and configuration	101
3.3.1 Remote Control Proxy installation	101
3.3.2 Remote Control Proxy configuration	104
3.3.3 Firewall configuration table	108
3.3.4 Remote Control Proxy startup	109
<b>Chapter 4. Implementation scenario: Tivoli Firewall Security Toolbox</b>	115
4.1 Scenario overview	116
4.2 Environment description	116
4.2.1 Technical infrastructure	117
4.2.2 Data flow description	121
4.2.3 Firewall configuration tables	124
4.3 Scenario installation and configuration	125
4.3.1 Remote Control Proxy installation	125
4.3.2 Remote Control Proxy configuration	129
4.3.3 Remote Control Proxy startup	133
<b>Part 3. Troubleshooting</b>	139
<b>Chapter 5. Troubleshooting techniques</b>	141
5.1 Generic problem determination outline	142
5.1.1 Session startup	142
5.1.2 Session management	155
5.2 Troubleshooting the Remote Control Proxy	155
5.2.1 The rproxy.log file	155
5.2.2 The remcon.trc	158
5.3 Troubleshooting examples	160
5.3.1 Case 1: Controller not connecting to Target Proxy	160
5.3.2 Case 2: Target Proxy service is not active	163
5.3.3 Case 3: Wrong Proxy configuration	167
5.4 Troubleshooting the firewall	171
<b>Part 4. Appendixes</b>	173
<b>Appendix A. Tivoli Firewall Security Toolbox overview</b>	175
Introduction	176
Components of TFST	176
Endpoint Proxy	176
Gateway Proxy	176

Relay . . . . .	176
Event Sink . . . . .	177
Tivoli environments with single firewall . . . . .	177
Tivoli environments with multiple firewalls . . . . .	178
Sending events across firewalls . . . . .	179
Installation and configuration of TFST . . . . .	180
Installation of TFST . . . . .	180
Configuration of TFST . . . . .	181
TFST components and operations . . . . .	186
Port range configurations . . . . .	186
<b>Appendix B. Introducing firewalls . . . . .</b>	<b>189</b>
Introduction . . . . .	190
Functionality of a firewall . . . . .	190
Firewall tools . . . . .	190
Packet filters . . . . .	191
Proxy servers . . . . .	191
Socks . . . . .	192
Authentication . . . . .	192
DNS and mail gateways . . . . .	193
Network address translation (NAT) . . . . .	193
Virtual Private Networks . . . . .	194
Log management . . . . .	194
Firewalls in the market . . . . .	195
<b>Abbreviations and acronyms . . . . .</b>	<b>197</b>
<b>Related publications . . . . .</b>	<b>199</b>
IBM Redbooks . . . . .	199
Other publications . . . . .	199
Online resources . . . . .	200
How to get IBM Redbooks . . . . .	200
<b>Index . . . . .</b>	<b>201</b>





# Figures

1-1	Parent-Child hierarchy in RC Proxy-TFST architecture . . . . .	11
1-2	RC session data flow in a single-TMR environment . . . . .	14
1-3	RC session data flow in a multi-TMR environment . . . . .	22
1-4	RC session data flow in an RC Gateway/single-TMR environment. . . . .	32
1-5	RC session data flow in an RC Gateway/multi-TMR environment. . . . .	34
1-6	RC session data flow in an RC Proxy Standalone/single-TMR . . . . .	36
1-7	RC session data flow in an RC Proxy Standalone/multi-TMR . . . . .	40
1-8	RC session data flow in an RC Proxy-TFST/single-TMR environment . . . . .	46
1-9	RC session data flow in an RC Proxy-TFST/multi-TMR environment . . . . .	51
2-1	Planning overview for RC Proxy in a Standalone environment . . . . .	74
2-2	Planning overview for Remote Control Proxy in a TFST environment. . . . .	75
2-3	Case study scenario without RC Proxy architecture . . . . .	82
2-4	Case study scenario with RC Proxy architecture - Solution A . . . . .	84
2-5	Case study scenario with RC Proxy architecture - Solution B . . . . .	88
3-1	General testing scenario . . . . .	96
3-2	RC Proxy Implementation . . . . .	99
3-3	Remote Control Data Flow Overview. . . . .	100
3-4	Remote Control Data Flow Overview. . . . .	108
3-5	Startup of Remote Control Proxy using Service Applet . . . . .	110
4-1	General TFST testing scenario . . . . .	118
4-2	Remote Control Proxy Implementation in a TFST environment . . . . .	120
4-3	Data flow overview: Non-Standalone scenario . . . . .	122
5-1	Endpoint problem determination flow. . . . .	144
5-2	TFST problem determination flow . . . . .	148
5-3	RC Proxy problem determination flow . . . . .	152
5-4	Error message displayed on Controller when attempt a session. . . . .	160
5-5	Error message displayed on the Controller at session startup . . . . .	163
5-6	Error message at session startup: Proxy configuration problem . . . . .	167
A-1	Tivoli Endpoint and Gateway proxies communication through firewall . . . . .	177
A-2	Relay connecting Endpoint and Gateway proxies through a DMZ . . . . .	178
A-3	Event Sink collecting non-TME events . . . . .	179



# Tables

2-1	RC ports for unidirectional communication - Parent/initiator . . . . .	63
2-2	RC ports for unidirectional communication - Parent/listener . . . . .	64
2-3	RC ports for unidirectional communication - Relay - Parents/initiators .	65
2-4	RC ports for unidirectional communication - Relay - Parents/listeners .	67
2-5	RC ports for bidirectional communication . . . . .	69
2-6	RC ports for bidirectional communication with Relay. . . . .	71
2-7	Hardware requirements for IBM Tivoli Remote Control Proxy . . . . .	76
2-8	Software requirements for IBM Tivoli Remote Control Proxy. . . . .	77
2-9	RC Proxy network ports for firewall 1 - Solution A. . . . .	86
2-10	RC Proxy network ports for firewall 2 - Solution A. . . . .	87
2-11	RC Proxy network ports for firewall 3 - Solution A. . . . .	87
2-12	RC Proxy network ports for firewall 1 - Solution B. . . . .	90
2-13	RC Proxy network ports for firewall 2 - Solution B. . . . .	90
2-14	RC Proxy network ports for firewall 3 - Solution B. . . . .	90
3-1	RC Target Proxy settings. . . . .	102
3-2	RC Controller Proxy settings . . . . .	103
3-3	Scenario firewall configuration table . . . . .	108
4-1	Summary of Framework and Remote Control resources . . . . .	121
4-2	Summary of port configuration. . . . .	123
4-3	Firewall 1 configuration table . . . . .	124
4-4	Firewall 2 configuration table . . . . .	124
4-5	RC Target Proxy installation settings. . . . .	126
4-6	Relay instance installation settings . . . . .	127
4-7	RC Controller Proxy installation settings . . . . .	128



# Examples

1-1	RC session trace in a single-TMR environment . . . . .	16
1-2	The remote_control method from a single-TMR environment . . . . .	19
1-3	The is_proxied_ep method from a single-TMR environment . . . . .	20
1-4	The nd_start_target method from a single-TMR environment . . . . .	20
1-5	The nd_start_controller method from a single-TMR environment . . . . .	20
1-6	RC session trace from the HUB TMR in a multi-TMR environment . . . . .	25
1-7	RC session trace from the Spoke TMR in a multi-TMR environment . . . . .	25
1-8	The remote_control method from a Spoke TMR . . . . .	28
1-9	The is_proxied_ep method from a Spoke TMR . . . . .	29
1-10	The nd_start_target method from a Spoke TMR . . . . .	29
1-11	The nd_start_controller method from a Spoke TMR . . . . .	29
1-12	The nd_start_controller method from a HUB TMR . . . . .	30
1-13	The rc_def_gw default policy method for Remote Control . . . . .	33
1-14	The rc_def_proxy default policy method for Remote Control . . . . .	38
1-15	The is_proxied_ep method for an RC Proxy Standalone architecture . . . . .	43
1-16	The nd_start_target method for an RC Proxy Standalone architecture . . . . .	43
1-17	The nd_start_controller method for RC Proxy Standalone architecture . . . . .	44
1-18	The rc_def_proxy default policy method for Remote Control . . . . .	49
1-19	The is_proxied_ep method for an RC Proxy-TFST architecture . . . . .	54
1-20	The nd_start_target method for an RC Proxy-TFST architecture . . . . .	55
1-21	The nd_start_controller method for an RC Proxy-TFST architecture . . . . .	55
3-1	Hub TMR region . . . . .	97
3-2	Spoke TMR region . . . . .	97
3-3	Hub TMR Endpoint Gateway . . . . .	98
3-4	Spoke TMR Endpoint Gateway . . . . .	98
3-5	Remote Control Target Proxy configuration file . . . . .	104
3-6	Remote Control Controller Proxy configuration file . . . . .	105
3-7	Target Proxy local-port-range definition . . . . .	105
3-8	Remote Control Proxy routing table configuration file . . . . .	106
3-9	The rc_def_proxy policy method contents . . . . .	107
3-10	How to modify the rc_def_proxy policy method . . . . .	107
3-11	Startup of Remote Control Proxy on AIX operating system . . . . .	109
3-12	The rcproxy.log: RC Target Proxy log file . . . . .	110
3-13	The rcproxy.log: RC Controller Proxy log file . . . . .	111
3-14	The netstat output collected on the RC Target Proxy . . . . .	111
3-15	The netstat output collected on the Controller Proxy . . . . .	112
3-16	The output of the rcproxy -list command . . . . .	113
4-1	RC Controller Proxy configuration file . . . . .	129

4-2	RC Target Proxy configuration file example . . . . .	130
4-3	Modification settings example . . . . .	130
4-4	The Relay.cfg after the installation. . . . .	131
4-5	The Relay.cfg file after the changes . . . . .	132
4-6	The rc_def_proxy policy method contents . . . . .	132
4-7	The rcproxy.log: RC Target Proxy log file . . . . .	133
4-8	The Relay.log: Relay log file contents . . . . .	134
4-9	The rcproxy.log: RC Controller Proxy log file. . . . .	134
4-10	The netstat output collected on the RC Target Proxy . . . . .	135
4-11	The netstat output collected on the Relay . . . . .	135
4-12	The netstat output collected on the Controller Proxy . . . . .	136
4-13	The output of the rcproxy -list command . . . . .	137
5-1	The rcproxy.log file settings in the rcproxy.cfg file . . . . .	155
5-2	The Target Proxy log file . . . . .	156
5-3	The Controller Proxy log file. . . . .	157
5-4	The remcon.trc file for the Controller machine. . . . .	158
5-5	The Target Proxy log file . . . . .	161
5-6	The Controller Proxy log file. . . . .	161
5-7	The remcon.trc file . . . . .	162
5-8	The rc_def_proxy policy method changes in order to fix the problem . . . . .	162
5-9	The Endpoint Proxy log file . . . . .	163
5-10	The Relay log file . . . . .	164
5-11	The Gateway Proxy log file . . . . .	164
5-12	The Target Proxy log file . . . . .	165
5-13	The Relay log file (instance used by remote control proxies) . . . . .	166
5-14	The Controller Proxy log file. . . . .	166
5-15	The remote control Target Proxy log file . . . . .	167
5-16	The remote control Relay log file . . . . .	168
5-17	The remote control Controller log file. . . . .	169
5-18	The Relay configuration file . . . . .	169
5-19	Wrong Target Proxy configuration file . . . . .	170

# Notices

This information was developed for products and services offered in the U.S.A.

IBM may not offer the products, services, or features discussed in this document in other countries. Consult your local IBM representative for information on the products and services currently available in your area. Any reference to an IBM product, program, or service is not intended to state or imply that only that IBM product, program, or service may be used. Any functionally equivalent product, program, or service that does not infringe any IBM intellectual property right may be used instead. However, it is the user's responsibility to evaluate and verify the operation of any non-IBM product, program, or service.

IBM may have patents or pending patent applications covering subject matter described in this document. The furnishing of this document does not give you any license to these patents. You can send license inquiries, in writing, to:

*IBM Director of Licensing, IBM Corporation, North Castle Drive Armonk, NY 10504-1785 U.S.A.*

*The following paragraph does not apply to the United Kingdom or any other country where such provisions are inconsistent with local law:* INTERNATIONAL BUSINESS MACHINES CORPORATION PROVIDES THIS PUBLICATION "AS IS" WITHOUT WARRANTY OF ANY KIND, EITHER EXPRESS OR IMPLIED, INCLUDING, BUT NOT LIMITED TO, THE IMPLIED WARRANTIES OF NON-INFRINGEMENT, MERCHANTABILITY OR FITNESS FOR A PARTICULAR PURPOSE. Some states do not allow disclaimer of express or implied warranties in certain transactions, therefore, this statement may not apply to you.

This information could include technical inaccuracies or typographical errors. Changes are periodically made to the information herein; these changes will be incorporated in new editions of the publication. IBM may make improvements and/or changes in the product(s) and/or the program(s) described in this publication at any time without notice.

Any references in this information to non-IBM Web sites are provided for convenience only and do not in any manner serve as an endorsement of those Web sites. The materials at those Web sites are not part of the materials for this IBM product and use of those Web sites is at your own risk.

IBM may use or distribute any of the information you supply in any way it believes appropriate without incurring any obligation to you.

Information concerning non-IBM products was obtained from the suppliers of those products, their published announcements or other publicly available sources. IBM has not tested those products and cannot confirm the accuracy of performance, compatibility or any other claims related to non-IBM products. Questions on the capabilities of non-IBM products should be addressed to the suppliers of those products.

This information contains examples of data and reports used in daily business operations. To illustrate them as completely as possible, the examples include the names of individuals, companies, brands, and products. All of these names are fictitious and any similarity to the names and addresses used by an actual business enterprise is entirely coincidental.

## COPYRIGHT LICENSE:

This information contains sample application programs in source language, which illustrates programming techniques on various operating platforms. You may copy, modify, and distribute these sample programs in any form without payment to IBM, for the purposes of developing, using, marketing or distributing application programs conforming to the application programming interface for the operating platform for which the sample programs are written. These examples have not been thoroughly tested under all conditions. IBM, therefore, cannot guarantee or imply reliability, serviceability, or function of these programs. You may copy, modify, and distribute these sample programs in any form without payment to IBM for the purposes of developing, using, marketing, or distributing application programs conforming to IBM's application programming interfaces.

# Trademarks

The following terms are trademarks of the International Business Machines Corporation in the United States, other countries, or both:

AIX®  
CT™  
eServer™  
Illustra™  
IBM®  
ibm.com®

pSeries™  
Redbooks™  
Redbooks (logo) ™  
SecureWay®  
SP™  
SP1®

Tivoli Enterprise™  
Tivoli Enterprise Console®  
Tivoli®  
TME 10™  
TME®

The following terms are trademarks of other companies:

ActionMedia, LANDesk, MMX, Pentium and ProShare are trademarks of Intel Corporation in the United States, other countries, or both.

Microsoft, Windows, Windows NT, and the Windows logo are trademarks of Microsoft Corporation in the United States, other countries, or both.

Java and all Java-based trademarks and logos are trademarks or registered trademarks of Sun Microsystems, Inc. in the United States, other countries, or both.

C-bus is a trademark of Corollary, Inc. in the United States, other countries, or both.

UNIX is a registered trademark of The Open Group in the United States and other countries.

SET, SET Secure Electronic Transaction, and the SET Logo are trademarks owned by SET Secure Electronic Transaction LLC.

Other company, product, and service names may be trademarks or service marks of others.



# Preface

System administrators and help desk personnel sometimes need access to remote PCs in order to resolve problems and assist users with important business applications. Most organizations will, at some point, need to expand their management of systems from their regular systems management environment to those that exist on the other side of firewalls. Tivoli® Remote Control allows a system administrator to control the keyboard and mouse input and monitor the display output of a remote machine, independently of the firewall architecture.

This book presents a concise documentation of known requirements for implementing the IBM Tivoli Remote Control 3.8 across firewalls.

This IBM® Redbook will prove invaluable for Tivoli system administrators and Tivoli designers and firewall administrators planning, designing, implementing, and operating a Remote Control environment that involves firewalls. The results from a variety of test scenarios are presented along with tabulated firewall configuration requirements for the various components involved in such solution.

## The team that wrote this redbook

This redbook was produced by a team of specialists from around the world working at the International Technical Support Organization, Austin Center.

**Edson Manoel** is a Software Engineer at the IBM Corporation, International Technical Support Organization (ITSO), Austin Center, working as an IT Specialist in the Systems Management area. Prior to joining the ITSO, Edson worked in the IBM Software Group as a Tivoli Technology Ambassador and in IBM Brasil Professional Services Organization as a Certified IT Specialist. He was involved in numerous projects, designing and implementing systems management solutions for IBM customers and Business Partners. Edson holds a BSc degree in Applied Mathematics from Universidade de Sao Paulo, Brazil.

**Francesca Balzi** is a Tivoli Software Engineer at the IBM Tivoli Software Laboratory, in Italy. She has 7 years of experience in Customer Support. Her areas of expertise include problem determination and source identification in the client-server environment. She is currently performing Level 2 support for the EMEA Geo on IBM Tivoli Remote Control and IBM Tivoli Configuration Manager.

**Sebastien Fardel** is an Advisory IT Specialist at IBM Corporation, Global Services, Switzerland, acting as a Tivoli Architect in the Performance and Availability and Configurations and Operations areas. He has been in the IT industry since 1996 and has experience in IT infrastructure management, programming, and Systems Management area. His e-mail is [sfa@ch.ibm.com](mailto:sfa@ch.ibm.com).

**Venkata Reddy** is a software Engineer working for IBM Software Labs in Bangalore, India. He has three years of IT experience and is working as part of networking software group. He leads the firewall India team for providing Level3 support and Enhancements for IBM SecureWay® firewall. His areas of expertise include network security and firewalls.

Thanks to the following people for their contributions to this project:

Joanne Luedtke, Lupe Brown, Wade Wallace, and Chris Blatchley  
International Technical Support Organization, Austin Center

Yvonne Lyon  
International Technical Support Organization, San Jose Center

Silvia Giacone, Nicola Milanese, and Ugo Madama  
Remote Control Development and Verification Team, IBM Rome

Alan Hsu  
Market Manager - Remote Control, IBM Software Group Austin

## Become a published author

Join us for a two- to six-week residency program! Help write an IBM Redbook dealing with specific products or solutions, while getting hands-on experience with leading-edge technologies. You'll team with IBM technical professionals, Business Partners and/or customers.

Your efforts will help increase product acceptance and customer satisfaction. As a bonus, you'll develop a network of contacts in IBM development labs, and increase your productivity and marketability.

Find out more about the residency program, browse the residency index, and apply online at:

[ibm.com/redbooks/residencies.html](http://ibm.com/redbooks/residencies.html)

## Comments welcome

Your comments are important to us!

We want our Redbooks™ to be as helpful as possible. Send us your comments about this or other Redbooks in one of the following ways:

- ▶ Use the online **Contact us** review redbook form found at:

[ibm.com/redbooks](http://ibm.com/redbooks)

- ▶ Send your comments in an Internet note to:

[redbook@us.ibm.com](mailto:redbook@us.ibm.com)

- ▶ Mail your comments to:

IBM Corporation, International Technical Support Organization  
Dept. JN9B Building 003 Internal Zip 2834  
11400 Burnet Road  
Austin, Texas 78758-3493





# Part 1

# Concepts and planning





# Remote Control sessions overview

System administrators often need to manage servers or workstations in distant secure locations — for example, in an outsourcing project. If a problem on one of these machines requires attention, the administrator traditionally has two options: try to resolve the problem over the telephone with an authorized person (with a high chance of miscommunication); or relocate to the user's location for problem determination (which is often impractical). IBM Tivoli Remote Control allows an administrator to control the keyboard and mouse input and monitor the display output of a remote machine even in zones protected by any kind of network controlling process like firewalls. In addition, the administrator can just monitor, reboot the PC, or transfer files in a really simple way.

In this chapter we cover the following topics:

- ▶ Business perspectives for a solution using IBM Tivoli Remote Control across firewalls
- ▶ An overview of the IBM Tivoli Remote Control functionality
- ▶ A detailed description of the IBM Tivoli Remote Control components that will help to manage machines inside secure areas
- ▶ A detailed description of each type of communication used to exchange information between the different zones

## 1.1 IBM Tivoli Remote Control overview

The purpose of this chapter is not only to explain how IBM Tivoli Remote Control works in general, but to emphasize its architecture and functionality in a firewall environment. Even though the architecture and implementation of IBM Tivoli Remote Control may differ when firewalls are involved from implementation to implementation, the IBM Tivoli Remote Control functionality will remain the same. Therefore, in order to fully understand how remote control sessions work across firewalls, it is important to understand how this works in a non-secure environment.

IBM Tivoli Remote Control (ITRC) provides a complete real-time solution for remote controlling the target systems. For all intents and purposes, the technician or administrator's keyboard and mouse become the primary keyboard and mouse for the target system for the duration of a remote control session. Functionalities such as chat, reboot, and file transfer are available to the administrator.

IBM Tivoli Remote Control runs on top of the IBM Tivoli Management Framework. However, in the context of a firewalls environment, some other components must be installed in order to simplify and secure the way that communications are exchanged between the different components of IBM Tivoli Remote Control. Before continuing and defining the complete Remote Control process across firewalls, it is important to first know and understand the utility and functionality of each component of IBM Tivoli Remote Control and of IBM Tivoli Management Framework.

### 1.1.1 IBM Tivoli Management Framework components

The IBM Tivoli Management Framework enables you to install and create several management components (services) that allow you to manage the resources in your network. You can install any or all of these services, depending on your organizational needs. As a minimum, one TMR server must be installed. The following is a list of the management services provided by the Tivoli Management Framework and a brief description of each:

#### **TMR Server**

The Tivoli Management Region (TMR) Server includes the libraries, binaries, data files, and graphical user interface (GUI) needed to install and manage your Tivoli environment. The TMR Server maintains the Object DataBase and coordinates all communications with Tivoli managed systems, like Managed Nodes and Endpoints (through Tivoli Endpoint Gateways). The server also performs the authentication and verification necessary to ensure the security of Tivoli Enterprise™ data.



<b>Managed Node</b>	A Tivoli Managed Node runs the same software that runs on a TMR Server. Managed Nodes maintain their own Object DataBases, which can be accessed by the TMR Server. When Managed Nodes communicate directly with other Managed Nodes, they perform the same communication or security operations as they would perform with the TMR Server. Although there is no clear distinction between managed systems and managing systems, the introduction of the Endpoints architecture leads to a paradigm shift. Managed Nodes are considered to be managing systems (hosting the desktop or running as a gateway), whereas endpoints are the managed systems.
<b>Endpoint Manager</b>	The Endpoint Manager establishes and maintains the relationship between an Endpoint and its assigned Gateway. It is involved in taking the Endpoint in charge when its assigned Gateway is no longer responding. It is also involved in identifying the Gateways that an Endpoint is assigned to when applications are trying to contact the Endpoint. The Endpoint Manager runs on top of the TMR Server and is automatically created during the TMR Server installation process.
<b>Endpoint Gateway</b>	The Endpoint Gateway provides access to the Endpoint methods and provides the communications with the TMR Server that the Endpoints occasionally require. A single Gateway can support communications with thousands of Endpoints and can launch methods on an Endpoint or run methods on the Endpoint's behalf. A Gateway is created on an existing managed node.
<b>Endpoint Proxy</b>	An Endpoint Proxy is an optional component that emulates Endpoints to the Gateway to simplify the Tivoli communications in a firewall environment through a common port. The Endpoint Proxy funnels requests for specific Endpoints through a single TCP/IP port and passes it down to a Relay or a Gateway Proxy. This component is part of the Tivoli Firewall Security Toolbox and must be installed on the same network zone as the Tivoli Endpoint Gateway on which it is connected.

<b>Relay</b>	The Relay component's purpose is to pass information sent to it up or down the chain to an Endpoint Proxy, Gateway Proxy, or other Relays. This component is optional and is part of the Tivoli Firewall Security Toolbox. It must be installed in the network zone between the Endpoint Proxy and the Gateway Proxy. Multiple Relays could be chained to allow this connection if Endpoint Proxy and Gateway Proxy are separated by multiple network zones. There can be multiple instances of the Relay running on the same machine.
<b>Gateway proxy</b>	A Gateway Proxy is an optional component that emulates a Gateway to the Endpoints to simplify the Tivoli communications in a firewall environment through a common port. The Endpoints are not explicitly aware of the fact that this destination is not truly a Gateway. This component is part of the Tivoli Firewall Security Toolbox and must be installed on the same network zone as the distant Endpoints.
<b>Endpoint</b>	A Tivoli Management Agent (TMA) is any system that runs an Endpoint service (or daemon). Typically, an Endpoint is installed on a machine that is not used for daily management operations. Endpoints run a very small amount of software and do not maintain a database. The majority of systems in most Tivoli Enterprise installations will be Endpoints.
<b>Policy Region</b>	A Policy Region is a collection of Tivoli resources that are governed by a common set of policies. A Policy Region is often created to represent a management domain or area of influence for one or more system administrators.
<b>Administrator</b>	Tivoli Administrators are persons who will be responsible for managing various aspects of enterprise wide systems management. Tivoli functionality allows administrative functions that may be performed at many levels and locations of the organization. Administrators may be individuals or groups of persons with different logins.
<b>Collection</b>	The Collection is a container that groups objects on a Tivoli Desktop, thus providing the Tivoli Administrator with as single view of related resources. Such Collections are defined when an Administrator has the need to centralize miscellaneous resources stored in different Policy Regions. A Collection provides a "shortcut" for using resources.

For more information about TMR Server, Managed Node, Endpoint Gateway, Endpoint and Policy Region, refer to *Tivoli Management Framework Planning for Deployment Guide*, GC32-0803.

For more information about Endpoint Proxy, Gateway Proxy and Relay, refer to *Firewall Security Toolbox User's Guide*, GC23-4826 and to *Tivoli Enterprise Management Across Firewalls*, SG24-5510.

## 1.1.2 IBM Tivoli Remote Control components

As already mentioned, the IBM Tivoli Remote Control is a client-server application that helps you take control over workstations on a network using a specific remote control technology. It could serve as a central location for monitoring and controlling machines at local or remote locations. The following is a definition list of the Remote Control components. Their installation is mandatory except for the Remote Control Proxies and the Remote Control Gateway, which are only used in environments where components of a Tivoli Management Region are separated by firewalls:

<b>RC Server</b>	The Remote Control Server (RC Server) component is installed on the TMR Server and on each Managed Node that will act as an Endpoint Gateway. It manages the Remote Control session request from a Remote Control Controller to a Remote Control Target until the connection between the two machines is successfully initiated.
<b>RC Tool</b>	The Remote Control Tool (RC Tool) is the Remote Control managed resource in the Tivoli Management Region and is associated with a Policy Region. This tool enables remote operations such as remote controlling or rebooting of a workstation, transferring files and chatting. Customizing the default Remote Control policies allows you to change the set of rules that will apply to the RC Tool within a Policy Region.
<b>RC Policies</b>	The Remote Control Policies consist of a set of rules, the so-called policy methods, that allows to change the default behavior and graphical appearance of Remote Control Tools.
<b>RC Controller</b>	The Remote Control Controller component is automatically installed on each Endpoint that initiates a Remote Control session. It will enable a Tivoli Administrator to take control of a remote target workstation to which it is linked over a network. This component is also known as Controller.

<b>RC Target</b>	The Remote Control Target component is automatically installed on each Endpoint when a session from a Remote Control Controller is initiated. This component is also known as Target.
<b>RC Controller Proxy</b>	The Remote Control Controller Proxy is an optional component which could be used to simplify the communication between Controllers and Targets in a firewall environment through a common port. In fact, this component simulates a Remote Control Controller to the Targets that are separated from the Controllers by firewalls. This component must be installed in the same network zone as the Targets. Nevertheless, this component could be either installed on top of a Endpoint/Gateway Proxy or as a Standalone component.
<b>RC Target Proxy</b>	The Remote Control Target Proxy is an optional component which could be used to simplify the communication between Controllers and Targets in a firewall environment through a common port. In fact, this component simulates Remote Control Targets to the Controllers that are separated from the Targets by firewalls. This component must be installed in the same network zone as Controllers. Nevertheless, this component could be either installed on top of a Endpoint/Gateway Proxy or as a Standalone component.
<b>RC Gateway</b>	The Remote Control Gateway is an optional component which could be used when direct link from the Controller to the Target is not authorized. Thus, in this case, a Remote Control Gateway needs to be installed on top of a Tivoli Endpoint Gateway.

### 1.1.3 Tivoli components and communication symbols

In the figures and scenarios that follow, we use the following set of symbols to denote the various components and type of communication for easy recognition:

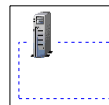

Tivoli Management Region Server (blue line)



Endpoint Gateway, Remote Control Server, Endpoint Manager or Instance of the Tivoli Firewall Security Toolbox Relay



Endpoint, Remote Control Controller or Remote Control Target

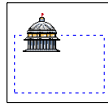

Policy Region (blue line)



Collection (blue line)

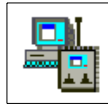

Remote Control Tool



Endpoint Proxy or Gateway Proxy (black line)



Remote Control Target Proxy or Remote Control Controller Proxy

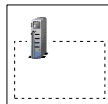

Instance 1 of the Tivoli Firewall Security Toolbox Relay (black line)

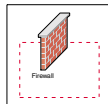

Network zone secured by a firewall (red line)

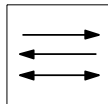

Tivoli Framework communication (black line)

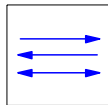

Tivoli Remote Control session communication (blue line)

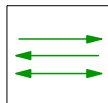

Tivoli proprietary protocol encapsulated in HTTP (green line)

## 1.1.4 Parent-Child concept

The hierarchy of the components of either the Tivoli Firewall Security Toolbox or the Remote Control Proxies (either RC Target Proxy or RC Controller Proxy) is presented in terms of a Parent-Child relationship. Such hierarchy is a subset of the whole Tivoli Top-Down hierarchy. It means that the starting point is the TMR Server and the ending point is the Endpoint. The components close to the TMR Server will be Parents and the ones close to the Endpoints will be Children. However, some components could, at the same time, be a Child and a Parent, as they are just in between the Parent-Child hierarchy. You must also notice that a Parent could have more than one Child but that a Child could only have one Parent.

As the Endpoint Proxy, which simulates Endpoints, is the closest element from the TMR Server, it is a Parent and, as it is directly connected to a Tivoli Gateway, it could not have any Parent. As the Gateway Proxy, which simulates a Tivoli Gateway, is the closest element from the Endpoints, it is a Child and as it the most closest component from the bottom of the hierarchy, it could not have any Child. A Relay could be either a Parent or a Child. When it is connected to an Endpoint Proxy or to another Relay, it becomes a Child of those components. In another way, when a Gateway Proxy or another Relay connects to a Relay, this one also becomes a Parent for these components.

In the case of Remote Control Proxies being installed on top of the Tivoli Firewall Security Toolbox components, the RC Proxy (either Target or Controller Proxy) installed on the Endpoint Proxy is a Parent of Relays or other RC Proxies. The RC Proxy installed on the Gateway Proxy is a Child of an RC Proxy installed on an Endpoint Proxy or a Relay. As no Remote Control components could be installed on the Relay, an RC Proxy could only be either a Parent or a Child, but not both at the same time.

If the Remote Control Proxies are installed as Standalone components, you have to decide on the Parent-Child role for each of the Proxies (Target and Controller Proxies). For configuration improvement, it is advised to configure the Target Proxy as the Parent and the Controller Proxy as the Child. This is because connection requests to the Target Proxy are done by the RC Controller. So, this request is always forwarded by the RC Target Proxy to the RC Controller Proxy. In this case, to logically respect a Top-Down hierarchy and to improve performance for the request, the RC Target should be the Parent.

Figure 1-1 depicts the Top-Down Proxy hierarchy when Remote Control Proxy components are installed on top of the Tivoli Firewall Security Toolbox.

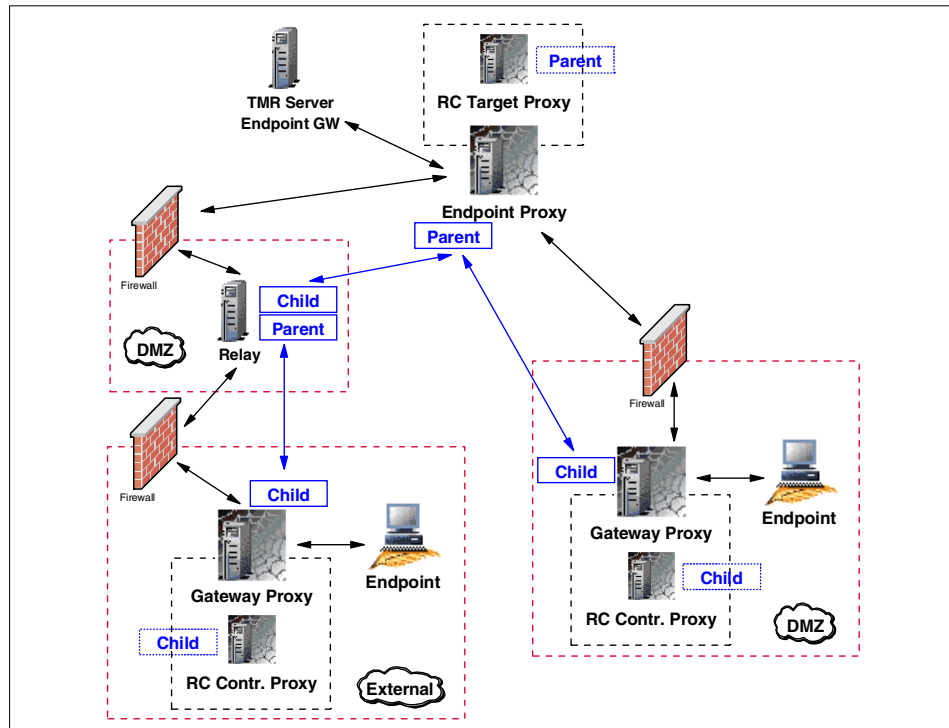

Figure 1-1 Parent-Child hierarchy in RC Proxy-TFST architecture

**Note:** Understanding this hierarchy is important when you install and configure the components.

### 1.1.5 Proxy connection types

In some secure environments, the firewall's constraints are so high that only communications from the more secure environment to the less secure environments are allowed. Either the Tivoli Firewall Security Toolbox or the Remote Control Proxies communications are designed to support those constraints. Even though we explain the proxy connection types in this section using the Tivoli Firewall Security Toolbox components, the same is valid for the Remote Control Proxies.

Different types of communications are available. The key point is which component initiates the communication:

- ▶ **Bidirectional communication:** In simple secure environments, communications could be initiated either by a component on the less secure zone or by the one located on the more secure zone. For example, an Endpoint initiates an upcall that is intercepted by the Gateway Proxy and further sent to the Endpoint Proxy, which in turn will forward it to the Tivoli Endpoint Gateway. In reverse, the Endpoint Proxy could initiate a downcall to the Endpoint without any restrictions.
- ▶ **Unidirectional communication:** In more secure environments, communications could only be initiated by components located in one of the zones. For example, if an Endpoint needs to initiate an upcall, this one is intercepted by the Gateway Proxy and held until the Endpoint Proxy polls their Gateway Proxies, at configurable intervals, to check if any of them have data to be sent. In this case, the Endpoint Gateway is called the *Initiator*, as it will be responsible to poll their Child. The Gateway Proxy is called the *Listener*, as it will wait for a send request before being able to transfer any information. The poll interval is set to 2 seconds by default and could be configured by changing the `polling-interval` parameter in the `epproxy.cfg`, `gwproxy.cfg`, and/or `rcproxy.cfg` configuration files. For more information about the Endpoint and Gateway proxies configuration files, refer to Firewall Security Toolbox User's Guide, GC23-4826. The *IBM Tivoli Remote Control User's Guide*, SC23-4842, provides information for the Remote Control Proxies configuration files.

## 1.2 IBM Tivoli Remote Control sessions overview

In this section we describe in detail the data flow of Remote Control sessions used in different implementations. This is meant to help you to fully understand how the communications of Remote Control work and what you have to consider in your design in order to respect the firewall restrictions.

The example scenarios used in this section are based on commonly found Remote Control architecture implementations in which the RC Controller is installed on the most secure side of the firewall and the Targets on the less secure zone. These scenarios should provide you enough information to master others more complicated situations. Furthermore, only the Remote Control action is discussed, but the process is basically the same for the File Transfer action. More information for these actions can be found in the *IBM Tivoli Remote Control User's Guide*, SC23-4842.

**Attention:** Only the Remote Control and the File Transfer actions can use the Remote Control Proxy technology to cross firewalls.



The Remote Control session scenarios could be divided into the following categories.

- ▶ Sessions in a single-TMR environment with no firewall restrictions. It is important to understand how these kinds of sessions work, because the basic concepts remain valid for all others scenarios.
- ▶ Sessions in a multi-TMR environment with no firewall restrictions. At first it seems similar to the way Remote Control works in a single-TMR environment. However, the HUB-Spoke concept introduces new constraints that need to be discussed. For more information about HUB-Spoke concept, refer to the *Tivoli Management Framework Planning for Deployment Guide*, GC32-0803.
- ▶ Sessions with firewall restrictions using the Remote Control Gateway component. We will describe how sessions are established for both single-TMR and multi-TMR environments when using the Remote Control Gateway component.
- ▶ Sessions with firewall restrictions using StandAlone Remote Control Proxies. We will show how sessions can be established for both single-TMR and multi-TMR environments when using the Remote Control Proxies. This type of sessions are commonly known as Remote Control Proxies in *standalone mode*.
- ▶ Sessions with firewall restrictions using the Remote Control Proxies in conjunction with the TFST components. We will show how sessions can be established for both single-TMR and multi-TMR environments, as well as for multi-firewall environments when using the Remote Control Proxies installed on top of the TFST components.

**Note:** There are three different ways to start a Remote Control session:

- ▶ Using the Tivoli Desktop
- ▶ Via the Tivoli WEB interface
- ▶ Using the Tivoli command line

In the following sections, only the Tivoli Desktop process will be discussed. However, the Remote Control data flow for any of the above methods remains the same. The advantage to use the Tivoli WEB interface is that even if you are on a secure site, the process will use the HTTP protocol, which is firewall friendly, to get the Targets list.

Nevertheless, as the following sections do not describe the best way to start a session, but only how the session works, for illustrative purposes only, we decided to use the Tivoli Desktop interface. For more information on how to start a Remote Control session, refer to the *IBM Tivoli Remote Control User's Guide*, SC23-4842.

## 1.2.1 Session in a single-TMR environment

In order to fully understand how a Remote Control session works, it is important to know in detail the entire data flow between the different elements of IBM Tivoli Remote Control, starting with the most simple scenario.

### Data flow for single-TMR session

Figure 1-2 shows in detail how a Remote Control session works in a single-TMR environment without firewall restrictions.

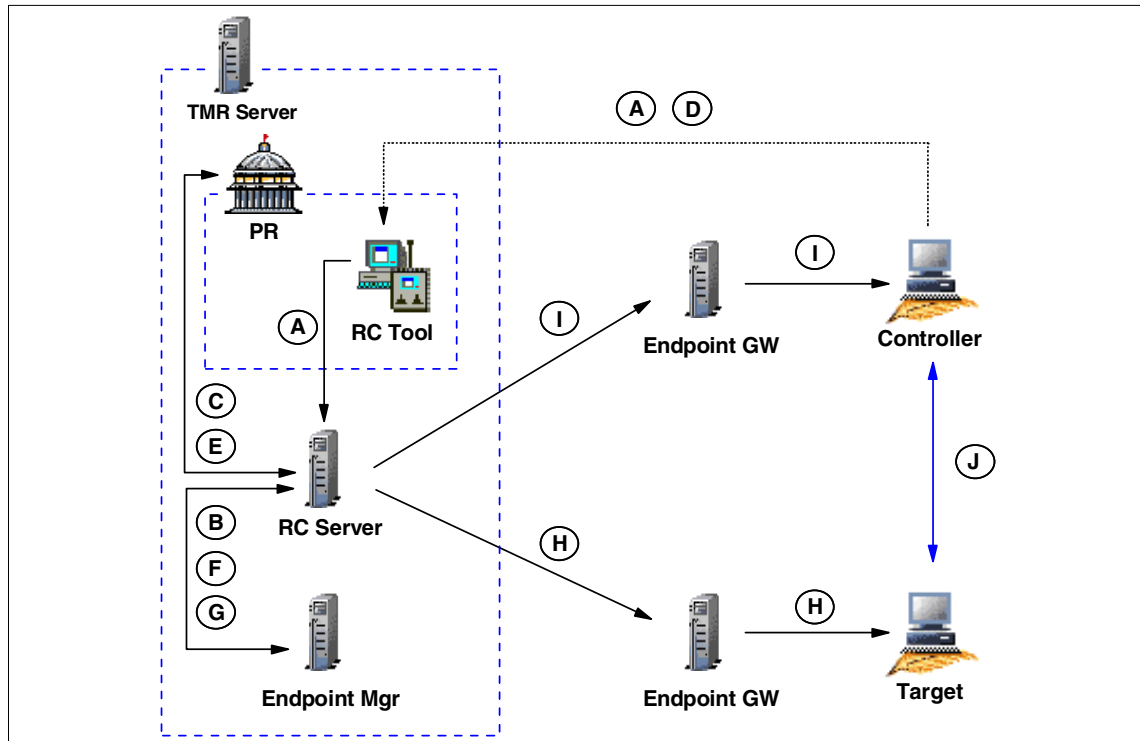

Figure 1-2 RC session data flow in a single-TMR environment

Based on Figure 1-2, here we provide a description of each step, from the time the Tivoli Administrator opens the Remote Control Tool (RC Tool) until the connection is established between the Controller and the Target.

The legend used in this diagram is explained as follows:

- A** The Tivoli Administrator must first open an RC Tool to be able to select a Target from a list. As the RC Tool is located in a Policy Region, it needs to be opened as well.

- B** As soon as the RC Tool is opened, the Remote Control Server needs to validate the Controller by checking:
- If the Controller is an Endpoint
  - If the label of the Endpoint is the same as of the hostname of the Controller
  - If the interpreter of the Controller is supported and able to start a Remote Control session

In order to get this information, the Remote Control Server needs to contact the Endpoint Manager.

- C** If the Controller is validated, the Remote Control Server loads a subset of the Remote Control policies from the Policy Region where the RC Tool is located. For our examples, we will call these *basis* policies. These *basis* policies are only accessed when the RC Tool is opened. No more are loaded for the time the Tool is active.

- D** At this point, the Tivoli Administrator can start a Remote Control session by clicking the **Run** button of the RC Tool after selecting a Target.

- E** The Remote Control Server needs to load the rest of the Remote Control policies. These policies are more network related and, for example, specifies if a Remote Control Proxy or a Remote Control Gateway should be used and which port are defined to start the session. Unlike the basis policies, these Remote Control policies are loaded every time a new session is started from this RC Tool. Example 1-1 shows which policies are read when the session starts, and which are read when the RC Tool is opened.

- F** As soon as all Remote Control policies are loaded, the Remote Control Server needs to obtain additional information for both the Controller and the Target, such as their IP addresses. In order to get this information, the Remote Control Server must contact the Endpoint Manager.

- G** Before initiating the connection, the Remote Control Server needs to know if the Target needs to be reached using an Endpoint Proxy/Gateway proxy infrastructure or not. If the Target is a proxied Endpoint, the Remote Control Server should send the request through an Endpoint Proxy instead of using the standard Tivoli Endpoint Gateway communication process.

- H** As soon as the Remote Control Server knows how it should contact the Target, it sends the `nd_start_target` method down to the Target and waits for the process to start. The local process started on the Target machine is named `EQNRCMAI.EXE`.

- I As soon as the Target is started, the Remote Control Server sends the `nd_start_controller` method to the Controller and waits for the process to start. The local process started on the Controller machine is named `EQNRSMAI.EXE`.
- J The Remote Control session is now established. It is important to notice that once the session established, the Controller talks directly with the Target; this is a peer-to-peer communication. The Target is listening on port 2501 (port 2502 for File Transfer and port 2503 for chat) by default. On the Controller side, by default, the port is assigned by the communication stack. However, these ports could be easily changed by configuring the `rc_def_ports` Remote Control Policy.

### Tracing for single-TMR session

Example 1-1 is a subset of the output from a IBM Tivoli Management Framework `odstat` command. It shows each method used to start a Remote Control session in a single-TMR environment as described above. This trace was captured from the time when a Tivoli Administrator opened an RC Tool until the session was established after the Administrator clicked the **Run** button of this RC Tool. This trace helps to fully depict the data flow shown in Figure 1-2 on page 14.

From the trace file, we can see what basis Remote Control policies are loaded when the Tivoli Administrator opens the RC Tool, and all the network related Remote Control policies that are loaded each time a Target request is started from a Controller. We can also see that the session is first started on the Target and then on the Controller before the peer-to-peer connection is established.

#### *Example 1-1 RC session trace in a single-TMR environment*

---

```
*****
Remote Control Tool is opened and RC Controller is checked.
*****

0.0.0 get_name_registry
1562174364.1.26 lookup
1562174364.1.1418#PcController::controller# _get_info
1562174364.1.26 lookup
1562174364.1.26 lookup
1562174364.1.4 lookup_id
1562174364.1.4##6@LCFData::ep_tnr_info_s describe
1562174364.1.26 lookup
1562174364.1.531#TMF_LCF::EpMgr# get_endpoint_key_value
1562174364.1.1413#PcRC::RemoteControl# get_policy_region
1562174364.1.1413#PcRC::RemoteControl# get_policy_region_name
1562174364.1.1413#PcRC::RemoteControl# _get_label
```

```
*****
“Basis” Remote Control Policies are loaded.
*****
```

```
1562174364.1.1127#TMF_PolicyRegion::GUI# rc_def_define
1562174364.1.1127#TMF_PolicyRegion::GUI# rc_def_uncheckedlist
0.0.0 get_name_registry
1562174364.1.26 lookup
1562174364.1.14#TMF_SysAdmin::Library# find_members
1562174364.1.184#TMF_SysAdmin::InstanceManager# find_members
1562174364.1.26 lookup
1562174364.1.4 lookup_id
1562174364.1.4##2@TMF_PolicyRegion::GUI describe
1562174364.1.4##2@TMF_PolicyRegion::GUI _get_type
1562174364.1.1139#TMF_PolicyRegion::GUI# find_members
0.0.0 get_name_registry
1562174364.1.26 lookup
1562174364.1.14#TMF_SysAdmin::Library# find_members
1562174364.1.184#TMF_SysAdmin::InstanceManager# find_members
1562174364.1.26 lookup
1562174364.1.4 lookup_id
1562174364.1.4##2@TMF_PolicyRegion::GUI describe
1562174364.1.4##2@TMF_PolicyRegion::GUI _get_type
1562174364.1.1141#TMF_PolicyRegion::GUI# find_members
1562174364.1.1413#PcRC::RemoteControl# _get_pres_object
1562174364.1.635#TMF_UI::Presentation# _get_dialogs
1562174364.1.635#TMF_UI::Presentation# _get_bitmaps
1562174364.1.1127#TMF_PolicyRegion::GUI# rc_def_command
1562174364.1.1127#TMF_PolicyRegion::GUI# rc_def_gw
1562174364.1.178#TMF_Administrator::Configuration_GUI# _get_label
1562174364.1.1127#TMF_PolicyRegion::GUI# rc_def_rcmode
1562174364.1.1127#TMF_PolicyRegion::GUI# rc_def_ftmode
1562174364.1.1127#TMF_PolicyRegion::GUI# rc_def_grace_time
1562174364.1.1127#TMF_PolicyRegion::GUI# rc_def_timeout_op
1562174364.1.1127#TMF_PolicyRegion::GUI# rc_def_optimize
1562174364.1.1127#TMF_PolicyRegion::GUI# rc_def_initstate
1562174364.1.1127#TMF_PolicyRegion::GUI# rc_def_alt_t
1562174364.1.1127#TMF_PolicyRegion::GUI# rc_def_backgrnd
1562174364.1.1127#TMF_PolicyRegion::GUI# rc_def_rate
1562174364.1.1127#TMF_PolicyRegion::GUI# rc_def_color
1562174364.1.1127#TMF_PolicyRegion::GUI# rc_def_inactivity
1562174364.1.1127#TMF_PolicyRegion::GUI# rc_def_gw
1562174364.1.1127#TMF_PolicyRegion::GUI# rc_def_comp
```

```
*****
Remote Control session is initiated by pressing the Run button of the RC Tool
*****
```

```

1562174364.1.1413#PcRC::RemoteControl# remote_control
1562174364.1.1127#TMF_PolicyRegion::GUI# rc_def_gw
1562174364.1.1127#TMF_PolicyRegion::GUI# rc_def_ports
1562174364.1.1127#TMF_PolicyRegion::GUI# rc_def_encryption
1562174364.1.1127#TMF_PolicyRegion::GUI# rc_def_proxy
1562174364.1.26 lookup
1562174364.1.531#TMF_LCF::EpMgr# get_endpoint_key_value
1562174364.21.517+#TMF_Endpoint::Endpoint# _get_label
1562174364.17.517+#TMF_Endpoint::Endpoint# _get_label
1562174364.1.26 lookup
1562174364.1.531#TMF_LCF::EpMgr# get_endpoint_key_value
1562174364.1.531#TMF_LCF::EpMgr# get_endpoint_key_value
1562174364.21.517+#TMF_Endpoint::Endpoint# is_proxied_ep
1562174364.21.517+#TMF_Endpoint::Endpoint# nd_start_target
1562174364.1.26 lookup
1562174364.1.531#TMF_LCF::EpMgr# get_endpoint_key_value
1562174364.17.517+#TMF_Endpoint::Endpoint# nd_start_controller
1562174364.1.26 lookup
1562174364.1.531#TMF_LCF::EpMgr# get_endpoint_key_value

```

---

In order to further explain the Remote Control session process, it is necessary to understand how the Remote Control Server knows which Controller the session is initiated from, and which Target the session should be started to. This information can be found in the IBM Tivoli Management Framework **wtrace** command output (**wtrace -jHk \$DBDIR**). This trace was captured at the same time as the **odstat** command trace. The following examples show the detailed information from the **wtrace** output about the most important lines of the IBM Tivoli Management Framework **odstat** trace file shown in Example 1-1 on page 16.

As a reference, the following information is important to understand the content of the examples:

- ▶ The object ID of the Target is 1562174364.21.517+#TMF\_Endpoint::Endpoint#
- ▶ The object ID of the Controller is  
1562174364.17.517+#TMF\_Endpoint::Endpoint#
- ▶ The Object ID of the Remote Control Tool  
1562174364.1.1413#PcRC::RemoteControl#
- ▶ The Tivoli Administrator who initiates this session is  
Root\_ITS0-region(ITS0\Administrator@ITS0)

Example 1-2 details the `remote_control` method which could also be named the Target request. It refers to the following line in Example 1-1 on page 16:

```
1562174364.1.1413#PcRC::RemoteControl# remote_control
```

*Example 1-2 The remote\_control method from a single-TMR environment*

---

```
loc-ic 687 M-hdoq 1-426 776
Time run: [Mon 27-Jan 17:11:33]

Object ID: 1562174364.1.1413#PcRC::RemoteControl#
Method: remote_control
Principal: ITS0\Administrator@ITS0 (8731208/0)
Path: /w32-ix86/TME/PCREMOTE/pcremote
Trans Id:
{
  1562174364:1,1562174364:1,220:135
}
#4
Input Data: (encoded):

{
  251658240
  [
    "WD_DIALOG_OWNER=1562174364.1.1413#PcRC::RemoteControl#"
    "WD_GADGET_PATH=" "WD_SOURCE_PATH=btn_run" "WD_DIALOG_NAME
    =pcremote" "WD_DIALOG_INSTANCE=3668:0" "WD_DESKTOP_OID=1562
    174364.1.549#TMF_UI::Extd_Desktop#" "WD_DESKTOP_PID=3436"
    "WD_DESKTOP_HOST=ITS0" "WD_DESKTOP_FQ_HOST=ITS0" "WD_DISPLAY
    =ITS0:0" "WD_OCO_OID=1562174364.1.178#TMF_Administrator:
    :Configuration_GUI#" "WD_VERSION=1" "WD_TYPE=Windows"
    "LANG=en" "LC_ALL=EN_US"
  ]
}
"1562174364.21.517+#TMF_Endpoint::Endpoint#" "1562174364.17.517
+#TMF_Endpoint::Endpoint#" 67109120 "controla" " /R50 /B /C8"
"" "Root_ITS0-region(ITS0\Administrator@ITS0)
```

---

Example 1-3 details the `is_proxied_ep` method. It refers to the following line in Example 1-1 on page 16:

```
1562174364.21.517+#TMF_Endpoint::Endpoint# is_proxied_ep
```

This method checks if the Target is behind an Endpoint Proxy/Gateway Proxy architecture. If the result is true, Remote Control knows that an Endpoint Proxy must be used to contact the Target. We can see that the result of this method is false; this means that the Target is not an Endpoint connected to a Gateway Proxy.

*Example 1-3 The is\_proxied\_ep method from a single-TMR environment*

---

```
loc-oc 699 9
Results: (encoded):
false
```

---

Example 1-4 details the `nd_start_target` method. It refers to the following line in Example 1-1 on page 16:

```
1562174364.21.517+#TMF_Endpoint::Endpoint# nd_start_target
```

This method is used to start the local Remote Control process on the Target. The **wtrace** command output doesn't show much information about this method in this type of architecture. However, it is important to know which method is used to start the session on the Target because, in some different situations, more information will be available for this method.

The return code of this method is 0; this means that the session starts without an error.

*Example 1-4 The nd\_start\_target method from a single-TMR environment*

---

```
loc-oc 700 23
Results: (encoded):
" 0
```

---

Example 1-4 detailed the `nd_start_controller` method. The **odstat** line is:

```
1562174364.17.517+#TMF_Endpoint::Endpoint# nd_start_controller
```

This method is used to start the local Remote Control process on the Controller. The **wtrace** process doesn't show much information about this method in this type of architecture. However, it is important to know which method is used to start the session on the Controller because, in some different situations, more information will be available for this method.

The return code of this method is 0; this means that the session starts without error.

*Example 1-5 The nd\_start\_controller method from a single-TMR environment*

---

```
loc-oc 703 12
Results: (encoded):
0
```

---



## 1.2.2 Session in a multi-TMR environment

In order to continue to master the Remote Control session processes, it is also important to know in detail the whole data flow between the different elements of IBM Tivoli Remote Control in a multi-TMR environment. In a HUB-Spoke architecture, all managed resources should be placed in the Spoke TMR, and all profiles dedicated for the management should be created in the HUB TMR. As RC Tools are managed resources, we assume that they are created in the Spoke TMR. We also assume that the Targets are all managed by the Spoke TMR.

However, in order to let the Tivoli Administrator manage the Spoke TMR's resources from the HUB TMR, the Controller has to be declared in the HUB TMR. This is because the resources of one Spoke TMR should never be able to directly access resources of another Spoke TMR; only the HUB TMR resources could manage all others. Furthermore, some resources, such as Endpoints, Policy Region, and RemoteControl, need to be exchanged between the HUB and Spoke TMRs. For more information about resources exchange between TMRs, refer to the *Tivoli Management Framework Planning for Deployment Guide*, GC32-0803.

### Data flow for a multi-TMR session

Figure 1-3 shows in detail how a Remote Control session is working in a HUB-Spoke TMR environment without firewall restrictions.

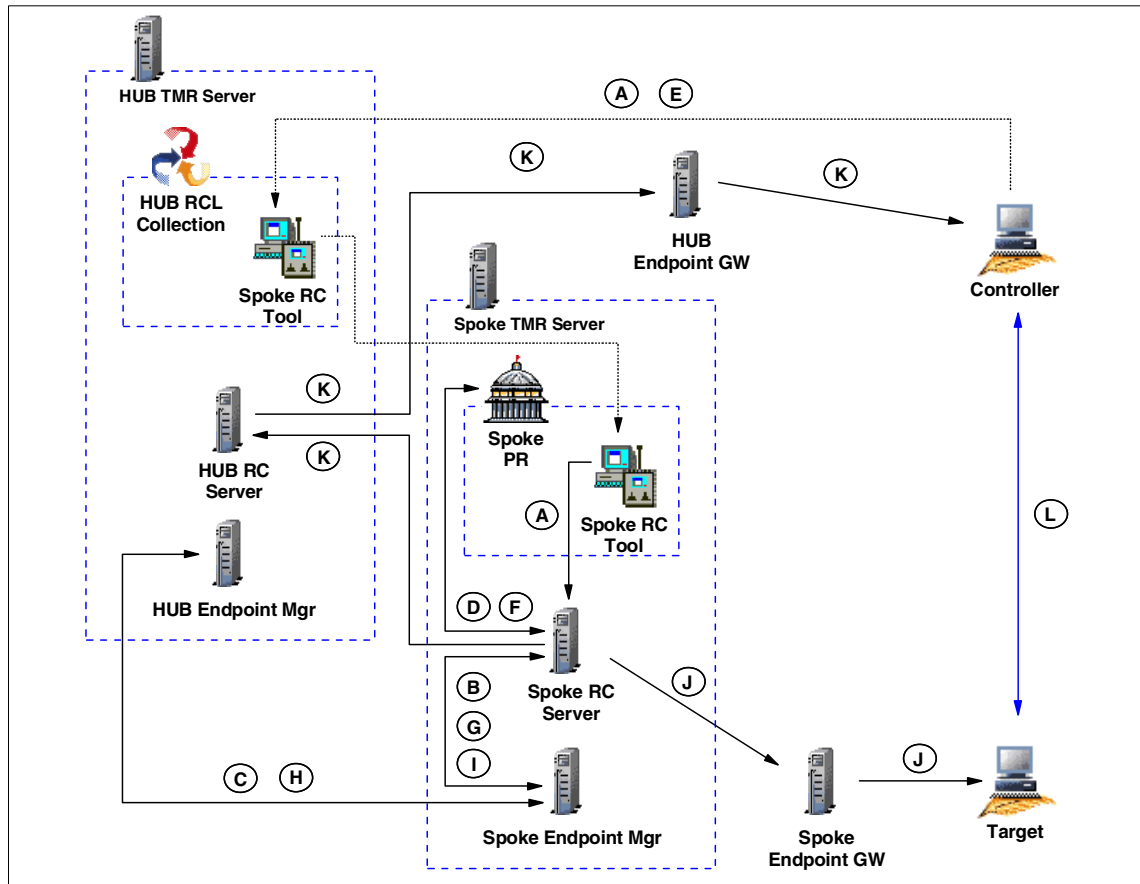

Figure 1-3 RC session data flow in a multi-TMR environment

Based on Figure 1-3, here we detail each step from the time when the Tivoli Administrator opens an RC Tool from a Collection located in the HUB TMR until the connection is established between the Controller and the Target.

The legend used in Figure 1-3 is explained as follows:

- A** The Tivoli Administrator must first open an RC Tool to be able to select a Target from a list. As the RC Tool is located in a Policy Region of the Spoke TMR, a Collection containing the Spoke RC Tool is available in the HUB TMR.
- B** As soon as the RC Tool on the Spoke is opened, the Spoke Remote Control Server needs to validate the Controller by checking:
  - If the Controller is an Endpoint.

- If the label of the Endpoint is the same as of the hostname of the Controller
- If the interpreter of the Controller is supported and able to start a Remote Control session.

In order to get this information, the Spoke Remote Control Server needs to contact the Spoke Endpoint Manager.

- C** As the Controller is not an Endpoint of the Spoke TMR, thus not known by the Spoke Endpoint Manager, the Spoke Endpoint Manager must get the Region ID from the Controller Object ID and must find a way to contact the Endpoint Manager of this other TMR known by the Region ID. As soon as the Spoke Endpoint Manager find the way to contact the HUB Endpoint Manager, it transfers the request it receives from the Spoke Remote Control Server and waits for the return.
- D** If the Controller, based on the information received from the HUB Endpoint Manager, is authorized to be a Controller, the Spoke Remote Control server loads a subset of the Remote Control policies. For our examples, we will call these policies *basis* policies. These policies are not loaded not from the Spoke RC Tool but from the Spoke Policy Region where the Tool is located. These *basis* policies are only accessed when the RC Tool is opened and no more loaded for the time the Tool is active.
- E** At this point, the Tivoli Administrator could decide to start a session by clicking the **Run** button of the Spoke Remote Control Tool after selecting a Target.
- F** The Spoke Remote Control Server needs to load the rest of the Remote Control policies. These policies are more network related and, for example, specify if a Remote Control Proxy or a Remote Control Gateway should be used and which ports are defined to start the session. Unlike the *basis* policies, these Remote Control policies are loaded every time a new session is started from this Spoke RC Tool. Example 1-7 on page 25 shows which policies are read when the session starts and which are read when the RC Tool is opened.
- G** As soon as all Remote Control policies are loaded, the Spoke Remote Control Server needs to obtain additional information for both the Controller and the Target, such as their IP addresses. In order to get this information, the Remote Control Server must contact the Spoke Endpoint Manager.

- H** The Spoke Endpoint Manager is able to provide information for the Target machine as this Endpoint is part of the same TMR. However, for the Controller, once again, it could not find any information for it inside its Endpoint Database. The Spoke Endpoint Manager needs to extract the Region ID of the Controller Object ID and must find a way to contact the HUB Endpoint Manager. As soon the Spoke Endpoint Manager find the way to contact the HUB Endpoint Manager, it transfers the request it receives from the Spoke Remote Control Server and waits for the return.
- I** Before initiating the connection, the Spoke Remote Control Server needs to know if the Target needs to be reached using an Endpoint Proxy/Gateway proxy infrastructure or not. If the Target is a proxied Endpoint, the Spoke Remote Control Server should send the request through an Endpoint Proxy instead of using the standard Tivoli Endpoint Gateway communication process.
- J** As soon as the Spoke Remote Control Server knows how to contact the Target, it sends the `nd_start_target` method down to the Target and waits for the process to start. The local process started on the machine is named `EQNRCMAI.EXE`.
- K** As soon as the Target is started, the Spoke Remote Control Server sends an `nd_start_controller` method to the Controller, but as it knows that the Controller is not part of the Spoke TMR, it forwards the request to the HUB TMR. The HUB Remote Control Server is sending the `nd_start_controller` method to the Controller and waits for the process to start. The local process started on the machine is named `EQNRSMAI.EXE`.
- L** The Remote Control session is now established. Notice that once the session established, the Controller talks directly with the Target; this is a peer-to-peer communication. The Target is listening on port 2501 (port 2502 for File Transfer and port 2503 for chat) by default. On the Controller side, by default, the port is assigned by the communication stack. However, these ports could be easily changed by configuring the `rc_def_ports` Remote Control Policy.

### Tracing for a multi-TMR session

Example 1-6 and Example 1-7 show subsets of IBM Tivoli Management Framework `odstat` command output from the HUB TMR and the Spoke TMR respectively. They show each method used to start a Remote Control session in a multi-TMR environment described above. This trace was captured from the time the Tivoli Administrator opened an RC Tool until the session was established after the Administrator clicked the **Run** button of this RC Tool. This trace helps to fully depict the data flow that was shown in Figure 1-3 on page 22.

From Example 1-7, we could analyze that all methods needed to get information from the HUB TMR are initiated on the Spoke TMR. Furthermore, all of these methods will be found again in the HUB TMR trace file. Even if these methods are initiated by the Spoke TMR, they are nevertheless managed by the HUB TMR. In the Spoke TMR trace file (Example 1-7), we could also see that all *basis* Remote Control policies are loaded when the Tivoli Administrator opens the RC Tool, and that all network related Remote Control policies are loaded each time a Target request is started from a Controller. In addition to that, we could also remark that the session is first started on the Target and then on the Controller before the peer-to-peer connection between them is established.

In order to understand the information shown in the trace files, the Region IDs of the HUB and Spoke TMRs in our environment are:

- ▶ HUB TMR: 1380596993
- ▶ Spoke TMR: 1519322503

Example 1-6 is the trace file from the HUB TMR Server.

*Example 1-6 RC session trace from the HUB TMR in a multi-TMR environment*

---

```
1380596993.1.536#TMF_LCF::EpMgr# get_endpoint_key_value
1380596993.1.536#TMF_LCF::EpMgr# get_endpoint_key_value
1380596993.1.179#TMF_Administrator::Configuration_GUI# _get_label
1380596993.1.631#TMF_UI::Extd_Desktop# connect
1380596993.7.522+#TMF_Endpoint::Endpoint# _get_label
1380596993.1.536#TMF_LCF::EpMgr# get_endpoint_key_value
1380596993.7.522+#TMF_Endpoint::Endpoint# nd_start_controller
1380596993.1.536#TMF_LCF::EpMgr# get_endpoint_key_value
```

---

Example 1-7 is the trace file from the Spoke TMR Server.

*Example 1-7 RC session trace from the Spoke TMR in a multi-TMR environment*

---

```
*****
Remote Control Tool is opened and RC Controller is checked.
*****

0.0.0 get_name_registry
1519322503.1.26 lookup
1519322503.1.26 lookup
1519322503.1.26 lookup
1519322503.1.26 lookup
1519322503.1.26 lookup
1519322503.1.4 lookup_id
1519322503.1.4##6@LCFData::ep_tnr_info_s describe
1519322503.1.26 lookup
1519322503.1.536#TMF_LCF::EpMgr# get_endpoint_key_value
```

```

1380596993.1.536#TMF_LCF::EpMgr# get_endpoint_key_value
1519322503.1.26 lookup
1519322503.1.536#TMF_LCF::EpMgr# get_endpoint_key_value
1380596993.1.536#TMF_LCF::EpMgr# get_endpoint_key_value
1519322503.1.707#PcRC::RemoteControl# get_policy_region
1519322503.1.707#PcRC::RemoteControl# get_policy_region_name
1519322503.1.707#PcRC::RemoteControl# _get_label

*****
“Basis” Remote Control Policies are loaded.
*****

1519322503.1.705#TMF_PolicyRegion::GUI# rc_def_define
1519322503.1.705#TMF_PolicyRegion::GUI# rc_def_uncheckedlist
0.0.0 get_name_registry
1519322503.1.26 lookup
1519322503.1.14#TMF_SysAdmin::Library# lookup_object
1519322503.1.521#TMF_SysAdmin::InstanceManager# get_instances_interface
1519322503.1.14#TMF_SysAdmin::Library# select_instance_managers
1519322503.1.26 get_all
1519322503.1.26 lookup
1519322503.1.4 lookup_id
1519322503.1.4##6@LCFData::ep_tnr_info_s describe
1519322503.1.707#PcRC::RemoteControl# _get_pres_object
1519322503.1.679#TMF_UI::Presentation# _get_dialogs
1519322503.1.679#TMF_UI::Presentation# _get_bitmaps
1519322503.1.705#TMF_PolicyRegion::GUI# rc_def_command
1519322503.1.705#TMF_PolicyRegion::GUI# rc_def_gw
1380596993.1.179#TMF_Administrator::Configuration_GUI# _get_label
1519322503.1.705#TMF_PolicyRegion::GUI# rc_def_rcmode
1519322503.1.705#TMF_PolicyRegion::GUI# rc_def_ftmode
1519322503.1.705#TMF_PolicyRegion::GUI# rc_def_grace_time
1519322503.1.705#TMF_PolicyRegion::GUI# rc_def_timeout_op
1519322503.1.705#TMF_PolicyRegion::GUI# rc_def_optimize
1519322503.1.705#TMF_PolicyRegion::GUI# rc_def_initstate
1519322503.1.705#TMF_PolicyRegion::GUI# rc_def_alt_t
1519322503.1.705#TMF_PolicyRegion::GUI# rc_def_backgrnd
1519322503.1.705#TMF_PolicyRegion::GUI# rc_def_rate
1519322503.1.705#TMF_PolicyRegion::GUI# rc_def_color
1519322503.1.705#TMF_PolicyRegion::GUI# rc_def_inactivity
1519322503.1.705#TMF_PolicyRegion::GUI# rc_def_gw
1519322503.1.705#TMF_PolicyRegion::GUI# rc_def_comp
1380596993.1.631#TMF_UI::ExtDesktop# connect
1519322503.1.26 lookup

*****
Remote Control session is initiated by pressing the Run button of the RC Tool
*****

```

```

1519322503.1.707#PcRC::RemoteControl# remote_control
1519322503.1.705#TMF_PolicyRegion::GUI# rc_def_gw
1519322503.1.705#TMF_PolicyRegion::GUI# rc_def_ports
1519322503.1.705#TMF_PolicyRegion::GUI# rc_def_encryption
1519322503.1.705#TMF_PolicyRegion::GUI# rc_def_proxy
1519322503.1.26 lookup
1519322503.1.536#TMF_LCF::EpMgr# get_endpoint_key_value
1519322503.18.522+#TMF_Endpoint::Endpoint# _get_label
1380596993.7.522+#TMF_Endpoint::Endpoint# _get_label
1519322503.1.26 lookup
1519322503.1.536#TMF_LCF::EpMgr# get_endpoint_key_value
1519322503.1.536#TMF_LCF::EpMgr# get_endpoint_key_value
1519322503.18.522+#TMF_Endpoint::Endpoint# is_proxied_ep
1519322503.18.522+#TMF_Endpoint::Endpoint# nd_start_target
1519322503.1.26 lookup
1519322503.1.536#TMF_LCF::EpMgr# get_endpoint_key_value
1380596993.1.536#TMF_LCF::EpMgr# get_endpoint_key_value
1380596993.7.522+#TMF_Endpoint::Endpoint# nd_start_controller
1519322503.1.26 lookup
1519322503.1.536#TMF_LCF::EpMgr# get_endpoint_key_value
1380596993.1.536#TMF_LCF::EpMgr# get_endpoint_key_value
1519322503.1.26 lookup
1519322503.1.88#TMF_SysAdmin::InstanceManager# connect

```

---

In order to explain how the Spoke Remote Control Server knows which Controller the session is initiated from and which Target the session should be started to, we need to analyze the output of the **wtrace** command from the Spoke TMR Server. This trace was captured at the same time as the **odstat** command trace.

The following examples will show the detailed information from the **wtrace** command output about the most important lines of the IBM Tivoli Management Framework **odstat** trace file shown in Example 1-6 on page 25 and in Example 1-7 on page 25.

As a reference, the following information is important to understand the content of the examples:

- ▶ The Object ID of the Target is  
1519322503.18.522+#TMF\_Endpoint::Endpoint#
- ▶ The Object ID of the Controller is  
1380596993.7.522+#TMF\_Endpoint::Endpoint#
- ▶ The Object ID of the RC Tool is 1519322503.1.707#PcRC::RemoteControl#
- ▶ The Tivoli Administrator who initiates the session is  
root@lpar07.itsc.austin.ibm.com

Example 1-8 details the `remote_control` method started from the Spoke TMR Server which could also be named the Target request. It refers to the following line in Example 1-7 on page 25:

```
1519322503.1.707#PcRC::RemoteControl# remote_control
```

*Example 1-8 The remote\_control method from a Spoke TMR*

---

```
loc-ic 4778 M-hdoq 1-4728 782
Time run: [Tue 28-Jan 17:47:15]

Object ID: 1519322503.1.707#PcRC::RemoteControl#
Method: remote_control
Principal: root@lpar07.itsc.austin.ibm.com (-2/-2)
Path: /aix4-r1/TME/PCREMOTE/pcremote
Trans Id:
{
  1519322503:1,1519322503:1,7:1207
}
#4
Input Data: (encoded):

{
  14
  [
    "WD_DIALOG_OWNER=1519322503.1.707#PcRC::RemoteControl#"
    "WD_GADGET_PATH=" "WD_SOURCE_PATH=btn_run" "WD_DIALOG_NAME
    =pcremote" "WD_DIALOG_INSTANCE=30278:0" "WD_DESKTOP_OID=138
    0596993.1.631#TMF_UI::Extd_Desktop#" "WD_DESKTOP_PID=1360"
    "WD_DESKTOP_HOST=TIC01008" "WD_DESKTOP_FQ_HOST=TIC01008"
    "WD_DISPLAY=TIC01008:0" "WD_OCO_OID=1380596993.1.179#TMF_A
    dministrator::Configuration_GUI#" "WD_VERSION=1" "WD_TYPE=Wi
    ndows" "LANG=en"
  ]
}
"1519322503.18.522+#TMF_Endpoint::Endpoint#" "1380596993.7.522+
#TMF_Endpoint::Endpoint#" 65540 "controla" " /R50 /B /C8" ""
"Root_tic01010-region(root@lpar07.itsc.austin.ibm.com)"
```

---

Example 1-9 details the `is_proxied_ep` method started from the Spoke TMR Server. It refers to the following line in Example 1-7 on page 25:

```
1519322503.18.522+#TMF_Endpoint::Endpoint# is_proxied_ep
```

This method checks if the Target is behind an Endpoint Proxy/Gateway Proxy architecture. If the result is true, Remote Control knows that an Endpoint Proxy must be used to contact the Target. We see that the result of this method is false; this means that the Target is not an Endpoint connected to a Gateway Proxy.



*Example 1-9 The is\_proxied\_ep method from a Spoke TMR*

---

```
loc-oc 4695 9
Results: (encoded):
false
```

---

Example 1-10 details the `nd_start_target` method started from the Spoke TMR Server. It refers to the following line in Example 1-7 on page 25:

```
1519322503.18.522+#TMF_Endpoint::Endpoint# nd_start_target
```

This method is used to start the local Remote Control process on the Target. The return code of this method is 0; this means that the session starts without error.

*Example 1-10 The nd\_start\_target method from a Spoke TMR*

---

```
loc-oc 4791 23
Results: (encoded):
" " 0
```

---

Example 1-11 details the `nd_start_controller` method started from the Spoke TMR Server. It refers to the following line in Example 1-7 on page 25:

```
1380596993.7.522+#TMF_Endpoint::Endpoint# nd_start_controller
```

This method is used to start the local Remote Control process on the Controller. However, this method is first started from the Spoke TMR, and as the Endpoint Manager of this TMR doesn't know the Controller Endpoint, the method must be transferred to the HUB TMR with all needed information.

As a reference, the Target IP address is 9.3.4.247 and the Controller IP address is 9.3.4.244.

The return code of this method is 0; this means that the session starts without error.

*Example 1-11 The nd\_start\_controller method from a Spoke TMR*

---

```
rem-ic 4795 M-H 1-4778 236
Time run: [Tue 28-Jan 17:47:22]

Object ID: 1380596993.7.522+#TMF_Endpoint::Endpoint#
Method: nd_start_controller
Principal: root@lpar07.itsc.austin.ibm.com (0/0)
Path:
Input Data: (encoded):
"\tivoli\pcremote\eqnrsmi.exe"
{
1
```

```

        [
            "/I9.3.4.247 /
        ],
        ,(?!?+;
    ]
        /Ntic01006 /
    ],
    ,(?!?+;
]
    /B18 /A /T /
]
;+?!((,,
]
    /HRoot_tic01010-region(root@lpar07.itsc.austin.ibm.com) /
]
;+?!((,,
]
"
]
}
65540 "9.3.4.244"

rem-oc 4795                                12
    Results: (encoded):
        0

```

---

Example 1-12 details the `nd_start_controller` method started from the HUB TMR Server. It refers to the following line in Example 1-6 on page 25:

```
1380596993.7.522+#TMF_Endpoint::Endpoint# nd_start_controller
```

As soon as the Spoke TMR asked the HUB TMR Server to start the Controller, the same `nd_start_controller` method is started on the HUB TMR Server. The return code of this method is 0; this means that the session starts without error.

*Example 1-12 The `nd_start_controller` method from a HUB TMR*

```

loc-oc 6483                                12
    Results: (encoded):
        0

```

---

### 1.2.3 Session using a Remote Control Gateway

In the following sections we describe how Remote Control sessions are established in a firewall environment using the Remote Control Gateway component for both single-TMR and multi-TMR environments. As this technology had been previously developed to allow Remote Control sessions in a firewall environment before the Remote Control Proxy technology was announced, we won't go into details on this process, and no trace will be discussed. Nevertheless, it could be interesting to have an idea of how it works to compare and understand the two different technologies.

The Remote Control Gateway must be installed on top of a Tivoli Endpoint Gateway. If you match the Remote Control Gateway port to your firewall configurations, you enable all Controllers to access all the Targets that reside on the other side of the firewall, through the same Remote Control Gateway. Furthermore, the Remote Control Gateway can't be used to bridge two different LAN.

#### **Data flow for RC Gateway/single-TMR session**

Figure 1-4 shows in detail how a Remote Control session works using a Remote Control Gateway in a single-TMR environment with firewall restrictions.

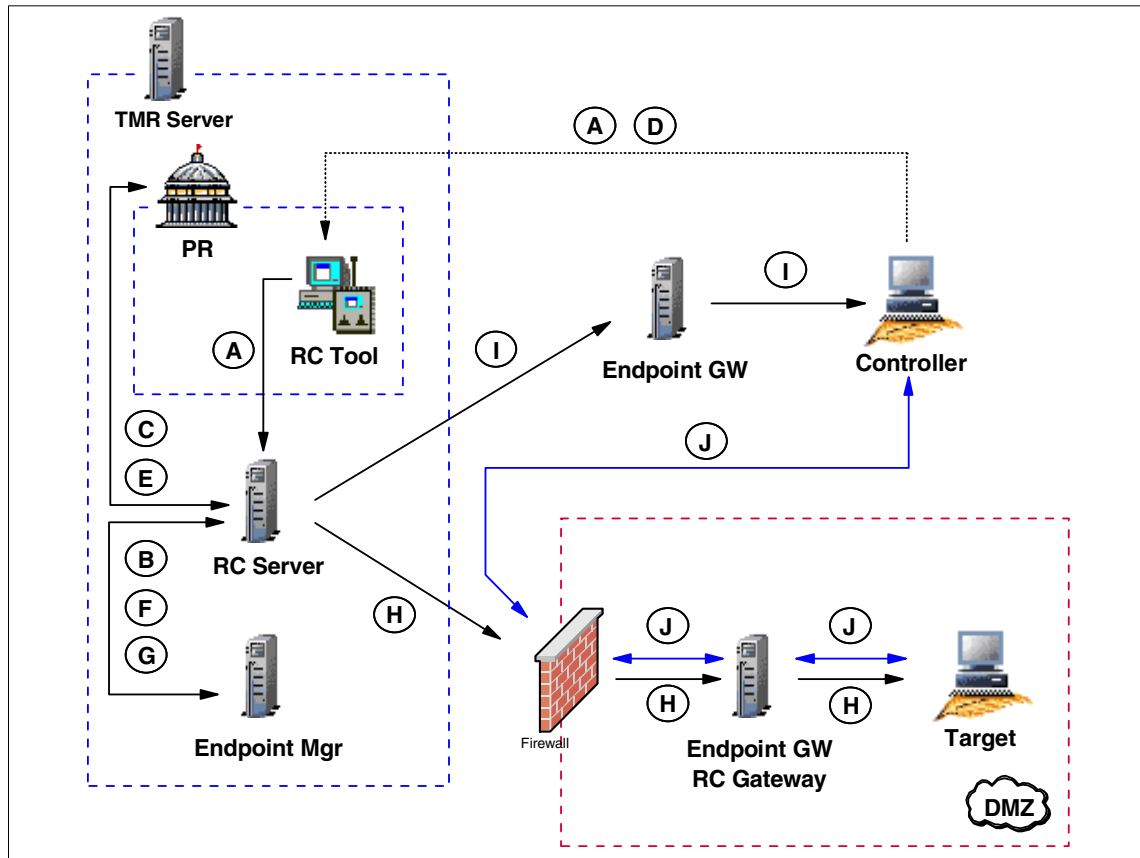

Figure 1-4 RC session data flow in an RC Gateway/single-TMR environment

Based on Figure 1-4, here we detail each step from the time the Tivoli Administrator opens a Remote Control Tool until the connection is established between the Controller and the Target.

The legend used in Figure 1-4 is explained as follows:

Steps **A, B, C, D, E, F, G, H** and **I** remain the same as for a Remote Control session in single-TMR environment without firewall restriction. Refer to “Data flow for single-TMR session” on page 14 for detailed information about these steps.

The remaining step is different and is defined as follows:

- J** The `rc_def_gw` policy has been configured to force the usage of the Remote Control Gateway, and the Remote Control Server has been informed of that on step **E**. The Remote Control server then has

informed the Controller (step I) to use the Remote Control Gateway in order to contact the Target. As the Controller knows on which Managed Node the Remote Control Gateway is installed and which port has to be used, it starts to communicate with the Target using this specific network path. The Remote Control session is now established. It is important to notice that once the session established, the Controller talks directly with the Target, but it's *not* a peer-to-peer communication (Controller-Target) anymore, as the communication flow must always go through the Remote Control Gateway. The Target is listening on the port defined in the `rc_def_gw` policy. If 0 is specified as the parameter, the port is assigned by the communication stack. On the Controller side, by default, the port is assigned by the communication stack. However, this port could be easily fixed by configuring the `rc_def_ports` Remote Control Policy.

In order to force the Remote Control session to use a Remote Control Gateway, the `rc_def_gw` default policy method needs to be configured as shown in Example 1-13.

*Example 1-13 The `rc_def_gw` default policy method for Remote Control*

---

```
#!/bin/sh
#
# Default policy method for Remote Control gateway
#
# This policy method determines whether or not to
# use the Remote Control gateway.
#
# Possible values:
# NO      Do not use the Remote Control gateway.
# YES <ManagedNode-label> <GatewayPort> <MaxSessions> IP:<IP-Port>
#        Use the specified Remote Control gateway,
#        where:
#        <ManagedNode-label> is the name of the managed node
#        to be used as Remote Control gateway.
#        <GatewayPort> is the TCP/IP port used by the Remote
#        Control gateway to listen for connection request from
#        controllers.
#        <MaxSessions> is the number of Tivoli Remote Control
#        sessions between a controller and target that the Remote
#        Control gateway can handle on the same incoming port.
#        The maximum value is 64.
#        <IP-Port> is the local TCP/IP port used by the Remote
#        Control gateway to communicate with TCP/IP targets.
#        If it has the value 0, the Remote Control gateway uses
#        a port generated by the communication stack.
#
# Default value: NO
```

echo "YES tic01002 8877 64 IP:0"

exit 0

## Data flow for an RC Gateway/multi-TMR session

Figure 1-5 shows in detail how a Remote Control session works using a Remote Control Gateway in a multi-TMR environment with firewall restrictions.

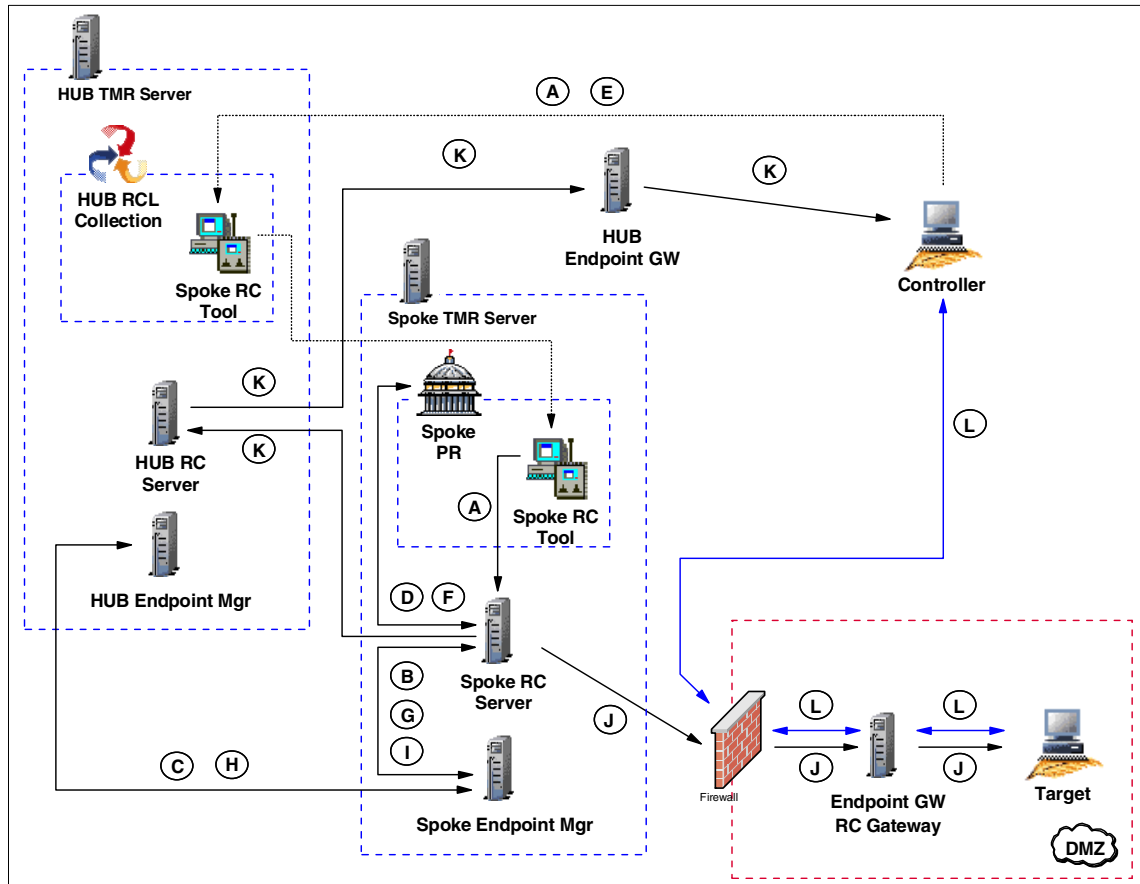

Figure 1-5 RC session data flow in an RC Gateway/multi-TMR environment

Based on Figure 1-5, here we detail each step from the time when the Tivoli Administrator opens a Remote Control Tool until the connection is established between the Controller and the Target.

The legend used in Figure 1-5 is explained as follows:

Steps **A, B,C, D, E, F, G, H, I, J,** and **K** remain the same as for a Remote Control session in a multi-TMR environment without the firewall restriction. Refer to “Data flow for a multi-TMR session” on page 21 for detailed information about these steps.

The remaining step is different and is defined as follows:

- L** The `rc_def_gw` policy has been configured to force the usage of the Remote Control Gateway and the Remote Control Server has been informed of that on step **F**. The Remote Control server then has informed the Controller (step **K**) to use the Remote Control Gateway in order to contact the Target. As the Controller knows on which Managed Node the Remote Control Gateway is installed and which port has to be used, it could start to communicate with the Target using this specific network path. The Remote Control session is now established. It is important to notice that once the session established, the Controller talks directly with the Target, but it's *not* a peer-to-peer communication (Controller-Target) anymore, as the communication flow must always go through the Remote Control Gateway. The Target is listening on port defined in the `rc_def_gw` policy. If 0 is specified as parameter, the port is assigned by the communication stack. On the Controller side, by default, the port is assigned by the communication stack. However, this port could be easily fixed by configuring the `rc_def_ports` Remote Control Policy.

In order to force the Remote Control session to use a Remote Control Gateway, the `rc_def_gw` default policy method needs to be configured as shown in Example 1-13 on page 33. This has to be done in the Spoke TMR where the Remote Control Object is located.

## 1.2.4 Session using Remote Control Proxies Standalone

In the following sections we describe the Remote Control Proxy Standalone architecture for both single-TMR and multi-TMR environments.

The Remote Control Proxy components enable machines on a side of a firewall to communicate, through a common definable port, to machines on the other side of the firewall. Thus, the Controller is able to start a session with a Target by minimizing the impact on the security infrastructure.

However, the Remote Control Proxy Standalone solution could only be used if a standard Tivoli Endpoint Gateway is installed in the same network zone as the Targets. Otherwise, the Remote Control Proxy on top of the Tivoli Firewall Security Toolbox solution needs to be deployed.

The RC Target Proxy emulates the Target located in another network zone to the Controller. The Target Proxy must be able to communicate with the Controller without any firewall constraints, and thus must be located in the same network zone as the Controller.

On the other side, the RC Controller Proxy emulates the Controller located in another zone to the Target. The Controller Proxy must be able to communicate with the Target without any firewall constraints, and thus must be located in the same network zone as the Target.

### Data flow for RC Proxy Standalone/single-TMR session

Figure 1-6 shows in detail how a Remote Control session works using a Remote Control Proxy Standalone architecture in a single-TMR environment with firewall restrictions.

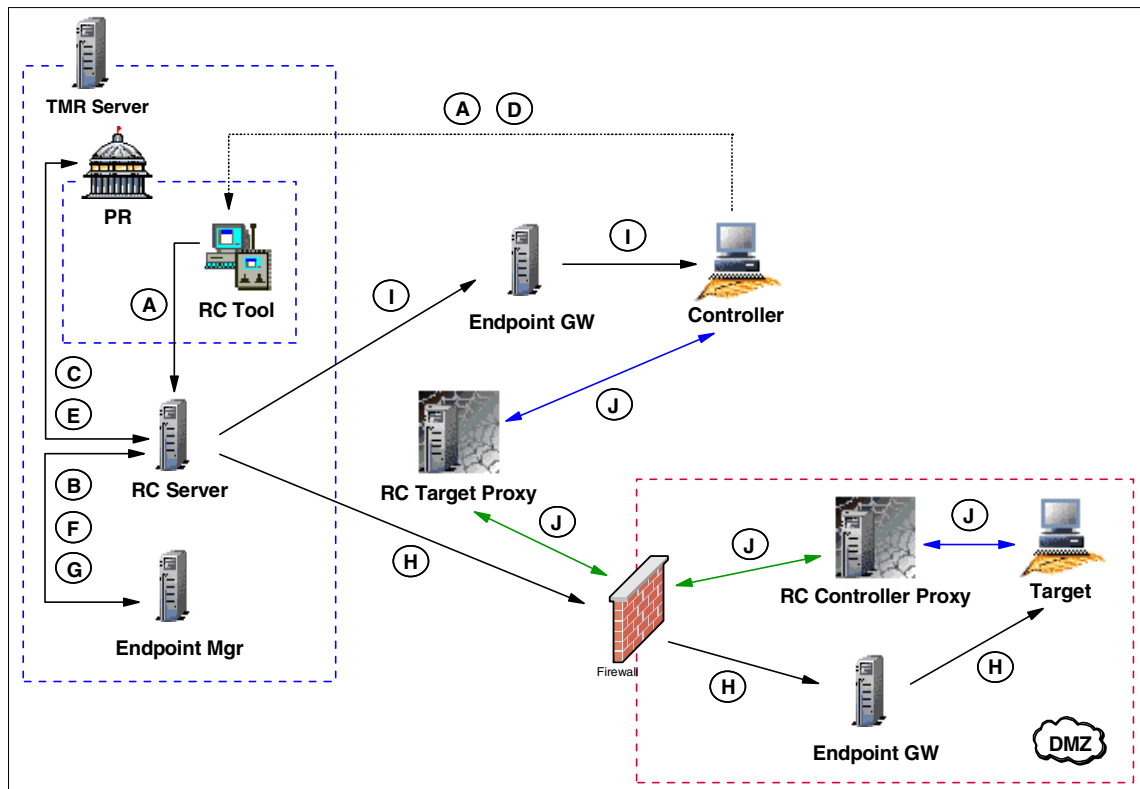

Figure 1-6 RC session data flow in an RC Proxy Standalone/single-TMR



Based on Figure 1-6, here we detail each step from the time the Tivoli Administrator opens a Remote Control Tool until the connection is established between the Controller and the Target using the Remote Control Proxies.

The legend used in Figure 1-6 is explained as follows:

Steps **A, B, C, D, E, F, G, H** and **I** are similar to a Remote Control session in single-TMR environment without firewall restriction. Refer to “Data flow for single-TMR session” on page 14 for detailed information about these steps.

The remaining step is different and defined as follows:

**J** Both sessions on the Target and on the Controller are now started. At this step, the Controller needs to establish the link to control the Target. The `rc_def_proxy` policy has been configured to force the usage of the Remote Control Proxies and the Remote Control Server has been informed of that on step **E**. The Remote Control server then has informed the Controller (step **I**) to use the RC Target Proxy in order to contact the Target. The Controller is able now to transfer the connection request to the RC Target Proxy as it got its IP address.

When the RC Target Proxy receives the request containing the IP address of the requested Target, it can start searching in the `rcproxy.route` file for the RC Controller Proxy the Target is connected to. In fact, this file contains a list of all distant Endpoints and their assigned RC Controller Proxy and needs to be manually customized. For more information about how to configure this file, refer to 3.3.2, “Remote Control Proxy configuration” on page 104. The RC Target Proxy then contacts the correspondent RC Controller Proxy to forward the Target connection request. The RC Controller Proxy uses the Target information stored in the first request to start a session with the Target.

The Remote Control session is now established. It is important to notice that once the session established, the Controller talks directly with the Target, but it's *not* a peer-to-peer communication (Controller-Target) anymore, as the communication flow must always go through the Remote Control Proxies.

The Target is listening on port defined in the `rc_def_ports` policy. On the Controller side, by default, the port is assigned by the communication stack. However, these ports could be easily changed by configuring the `rc_def_ports` Remote Control Policies. The RC Target Proxy and the RC Controller Proxy are listening on the port defined during the installation process. The port specified in the `rc_def_proxy` policy must be the same as defined during the installation process of the RC Target Proxy. The configuration of these RC Proxies ports could be reviewed by editing the `rcproxy.cfg`

configuration file. However, if you decided to change this port, you need to also review the `rc_def_proxy` policy. For more information about the RC Proxies configuration files, refer to *IBM Tivoli Remote Control User's Guide*, SC23-4842.

Sometimes, the Controller could be in a secure zone and managed by a local Tivoli Endpoint Gateway and the Target could be in another secure zone and also be managed by a local Tivoli Endpoint Gateway. In this case, two firewalls separate the Controller and its RC Target Proxy from the Target and its RC Controller Proxy. The TFST Relay could be installed in the zone between the two secure zones and used to pass the information between the RC Target Proxy and the RC Controller Proxy.

In order to implement the Remote Control session to use Remote Control Proxies, the `rc_def_proxy` default policy method needs to be configured as shown in Example 1-14.

*Example 1-14 The `rc_def_proxy` default policy method for Remote Control*

---

```
#!/bin/sh
#
# Default policy method for Remote Control Proxy
#
# This policy method determines whether to use Remote Control Proxies.
# If you use Remote Control Proxies, rc_def_proxy defines how the controller
# uses the Remote Control Proxies to start a session with a target across a
# firewall.
#
# Possible values:
#
# NO      Do not use the Remote Control Proxies.
#
# YES <configuration type> <rc proxy ip address> <rc proxy port>
#       Use the Remote Control Proxies, where:
#
#       <configuration type>
#               Identifies the following scenarios:
#
#               auto
#               The controller and Remote Control Proxies
#               search the route to the target using the
#               information stored by
#               Tivoli Firewall Security Toolbox.
#
#               manual
#               The Remote Control Proxies run as standalone.
#               The controller uses the network address that
#               you specify in this method to reach
```

```

#           the machine where the target
#           proxy runs.
#
#   <rc proxy ip address>
#           Identifies the machine where the target proxy
#           runs. You must use this parameter only with
#           the manual configuration type.
#
#   <rc proxy port>
#           Identifies the port that the target proxy uses to
#           communicate with the controller or the controller
#           proxy.
#
#   Default value: NO
#
#   Examples follow.
#
#   First example:
#   YES manual 192.168.100.50 3501
#
#   Second example:
#   YES auto 3501
#
#   Third example:
#   NO
#
echo "YES manual 9.3.4.169 8888"

exit 0

```

---

## Data flow for an RC Proxy Standalone/multi-TMR session

Figure 1-7 shows in detail how a Remote Control session works using a Remote Control Proxy Standalone architecture in a multi-TMR environment with firewall restrictions.

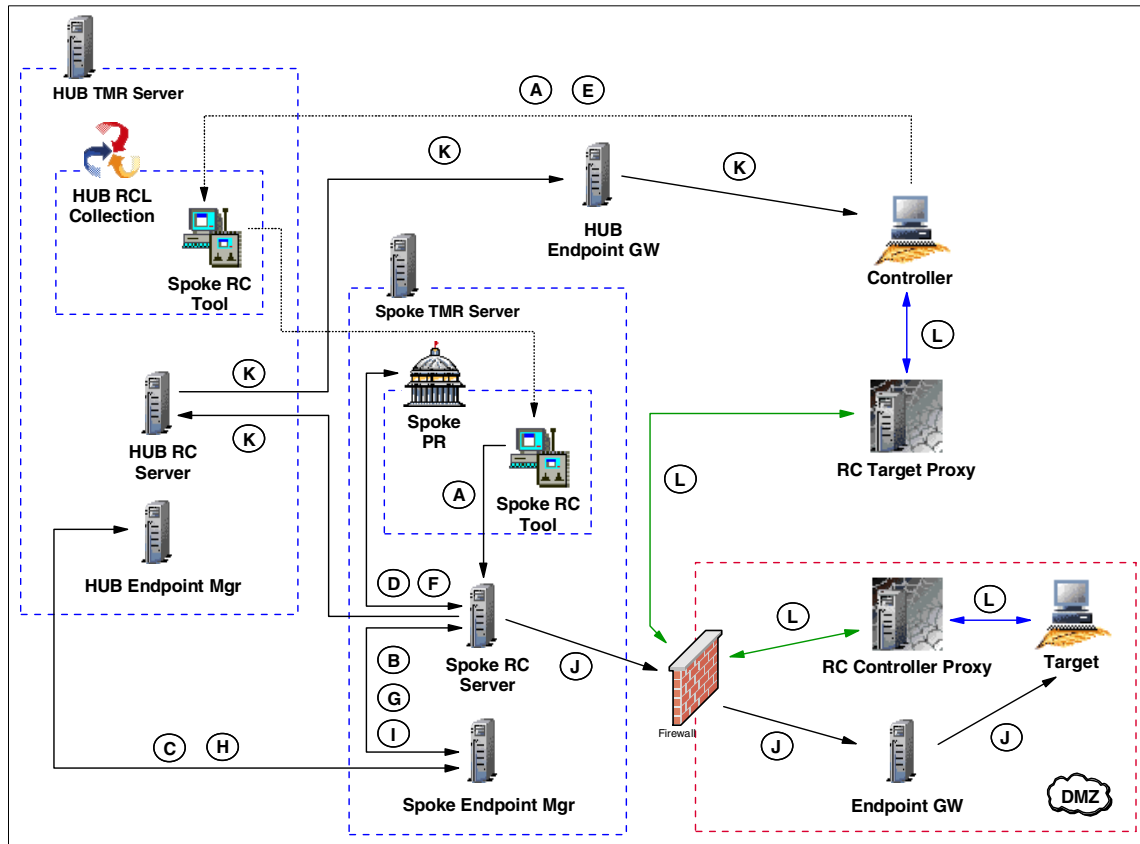

Figure 1-7 RC session data flow in an RC Proxy Standalone/multi-TMR

Based on Figure 1-7, here we detail each step from the time the Tivoli Administrator opens a Remote Control Tool until the connection is established between the Controller and the Target using the Remote Control Proxies.

The legend used in Figure 1-7 is explained as follows:

Steps **A, B, C, D, E, F, G, H, I, J** and **K** are similar to a Remote Control session in multi-TMR environment without firewall restriction. Refer to “Data flow for a multi-TMR session” on page 21 for detailed information about these steps.

The remaining step is different and defined as follows:

- L** Both sessions on the Target and on the Controller are now started. At this step, the Controller need to establish the link to control the Target. The `rc_def_proxy` policy has been configured to force the usage of the Remote Control Proxies and the Remote Control Server

has been informed of that on step **F**. The Remote Control server then has informed the Controller (step **K**) to use the RC Target Proxy in order to contact the Target. The Controller is able now to transfer the connection request to the RC Target Proxy as it got its IP address.

When the RC Target Proxy receives the request containing the IP address of the requested Target, it can start searching in the `rcproxy.route` file for the RC Controller Proxy the Target is connected to. In fact, this file contains a list of all distant Endpoints and their assigned RC Controller Proxy and needs to be manually customized. For more information about how to configure this file, refer to 3.3.2, “Remote Control Proxy configuration” on page 104. The RC Target Proxy then contacts the correspondent RC Controller Proxy to forward the Target connection request. The RC Controller Proxy uses the Target information stored in the first request to start a session with the Target.

The Remote Control session is now established. It is important to notice that once the session established, the Controller talks directly with the Target, but it's *not* a peer-to-peer communication (Controller-Target) anymore, as the communication flow must always go through the Remote Control Proxies.

The Target is listening on port defined in the `rc_def_ports` policy. On the Controller side, by default, the port is assigned by the communication stack. However, these ports could be easily changed by configuring the `rc_def_ports` Remote Control Policies. The RC Target Proxy and the RC Controller Proxy are listening on the port defined during the installation process. The port specified in the `rc_def_proxy` policy must be the same as defined during the installation process of the RC Target Proxy. The configuration of these RC Proxies ports could be reviewed by editing the `rcproxy.cfg` configuration file. However, if you decided to change this port, you need to also review the `rc_def_proxy` policy. For more information about the RC Proxies configuration files, refer to *IBM Tivoli Remote Control User's Guide*, SC23-4842

Sometimes, the Controller could be in a secure zone and managed by a local Tivoli Endpoint Gateway and the Target could be in another secure zone and also managed by a local Tivoli Endpoint Gateway. In this case, two firewalls separate the Controller and RC Target Proxy from the Target and RC Controller Proxy. The TFST Relay could be installed in the zone between the two secure zones and used to pass the information from the RC Target Proxy to the RC Controller Proxy

In order to implement the Remote Control session to use Remote Control Proxies, the `rc_def_proxy` default policy method needs to be configured as shown in Example 1-14 on page 38. This has to be done in the Spoke TMR where the Remote Control Object is located.

## Tracing for RC Proxy Standalone

The Tivoli methods used to start a session in a Remote Control Proxy Standalone architecture are the same used to start a session in a non-secure environment. Refer to Example 1-1 on page 16 for a subset of an IBM Tivoli Management Framework `odstat` output trace file for a single-TMR architecture and to the Example 1-6 on page 25 and Example 1-7 on page 25 for multi-TMR architecture.

Sections “Tracing for single-TMR session” on page 16 and “Tracing for a multi-TMR session” on page 24 provided the details of the most important methods used to start a Remote Control session both in a single-TMR and multi-TMR architecture. As mentioned, the methods are almost the same to start a Remote Control session in a secure environment. Thus, we only provide in this section the main differences for the most important methods.

The Target request, managed by the `remote_control` method, remains the same in a secure environment. For more information about this method, refer to Example 1-2 on page 19 for a single-TMR architecture and to Example 1-8 on page 28 for a multi-TMR architecture.

Example 1-15 details the `is_proxied_ep` method started from either the TMR Server in a single-TMR architecture or from the Spoke TMR Server in a multi-TMR architecture. It refers to the following line in Example 1-7 on page 25:

```
1519322503.29.522+#TMF_Endpoint::Endpoint# is_proxied_ep
```

This method checks if the Target is behind an Endpoint Proxy/Gateway Proxy architecture. If the result is `true`, Remote Control knows that an Endpoint Proxy must be used to contact the Target. We see that the result of this method is `false`; this means that the Target is not an Endpoint connected to a Gateway Proxy.

As a reference, the following information is important to understand the content of the examples:

- ▶ The Target IP address is 10.10.10.7
- ▶ The RC Target Proxy IP address is 9.3.4.169 and it is defined in the `rc_def_proxy` policy file
- ▶ The Controller IP address is 9.3.4.244

*Example 1-15 The is\_proxied\_ep method for an RC Proxy Standalone architecture*

---

```
rem-ic 695 M-H 1-683 21
      Time run: [Thu 30-Jan 11:42:46]

      Object ID: 1519322503.29.522+#TMF_Endpoint::Endpoint#
      Method: is_proxied_ep
      Principal: root@tic01002 (0/0)
      Path:
      Input Data: (encoded):
                  "10.10.10.7"

rem-oc 695 9
      Results: (encoded):
                  false
```

---

Example 1-16 details the `nd_start_target` method started from either the TMR Server in a single-TMR architecture or from the Spoke TMR Server in a multi-TMR architecture. It refers to the following line in Example 1-7 on page 25:

```
1519322503.18.522+#TMF_Endpoint::Endpoint# nd_start_target
```

This method is used to start the local Remote Control process on the Target. The return code of this method is 0; this means that the session starts without error.

*Example 1-16 The nd\_start\_target method for an RC Proxy Standalone architecture*

---

```
rem-ic 1517 M-H 1-1504 199
      Time run: [Thu 30-Jan 13:10:39]

      Object ID: 1519322503.29.522+#TMF_Endpoint::Endpoint#
      Method: nd_start_target
      Principal: root@tic01002 (0/0)
      Path:
      Input Data: (encoded):
                  "\tivoli\pcremote\eqnrcmai.exe"
                  {
                    3
                    [
                      "10.10.10.7" "/HRoot_tic01002-region(root@tic01002)"
                      " /R50 /B /C8 /V1519322503.1.702#PcRC::RemoteControl# /I"
                    ]
                  }
                  65540

rem-oc 1517 23
      Results: (encoded):
```

Example 1-17 details the `nd_start_controller` method started from the Spoke TMR Server in a multi-TMR architecture because it shows more useful information to understand how the information about the Target Proxy is passed to the Controller. It refers to the following line in Example 1-7 on page 25:

```
1380596993.7.522+#TMF_Endpoint::Endpoint# nd_start_controller
```

This method is used to start the local Remote Control process on the Controller. The 8888 number, in fact, is the port number on which the Target Proxy is listening. This port is configurable and defined in the `rc_def_proxy` Policy. The return code of this method is 0; this means that the session starts without error.

*Example 1-17 The `nd_start_controller` method for RC Proxy Standalone architecture*

```
rem-ic 972 M-H 1-955 256
Time run: [Thu 30-Jan 11:49:00]

Object ID: 1380596993.7.522+#TMF_Endpoint::Endpoint#
Method: nd_start_controller
Principal: root@lpar07.itsc.austin.ibm.com (0/0)
Path:
Input Data: (encoded):
    "\tivoli\pcremote\eqnrsmi.exe"
    {
        1
        [
            "/110.10.10.7 /
            ],
            ,(?!?+;
        ]
        /Ntic01007 /
    ],
    ,(?!?+;
    ]
    /C8888 /F9.3.4.169 /B29 /A /T /
    ]
    ;+?!((,,
    ]
    /HRoot_tic01010-region(root@lpar07.itsc.austin.ibm.com) /
    ]
    ;+?!((,,
    ]
    "
    ]
    }
65540 "9.3.4.244"
```



```
Results: (encoded):  
0
```

---

## 1.2.5 Session using Remote Control Proxies in a TFST environment

In the following sections we describe the Remote Control Proxy architecture running on top of Tivoli Firewall Security Toolbox for both single-TMR and multi-TMR environments.

The Remote Control Proxy components enable machines on one side of a firewall to communicate, through a common definable port, with machines on the other side of the firewall. The Controller is able to start a Target session by minimizing the impact on the security infrastructure.

The Remote Control Proxy-TFST solution can only be used if a Tivoli Firewall Security Toolbox environment is already deployed.

The Endpoint Proxy emulates the Endpoints located in another network zone to the standard Tivoli Gateway located in the same network zone as the TMR Server. Thus, the Endpoint Proxy is able to find the path to contact all distant Endpoints. In this context, the RC Target Proxy, which emulates the Target located in another network zone, could take the advantage of the Endpoint Proxy to find the way to contact the Targets. However, the Target Proxy must be able to communicate with the Controller without any firewall constraints, and thus must be located in the same network zone as the Controller.

On the other side, the RC Controller Proxy emulates the Controller located in another zone to the Target. The RC Controller Proxy must be able to communicate with the Target without any firewall constraints, and thus must be located in the same network zone as the Target. Furthermore, as the RC Target Proxy is installed on top of the Endpoint Proxy, the RC Controller Proxy must be installed on the top of the Gateway Proxy, which emulates a standard Tivoli Gateway to the distant Endpoints.

### Data flow for RC Proxy-TFST/single-TMR session

Figure 1-8 shows in detail how a Remote Control session works using a Remote Control Proxy - TFST architecture in a single-TMR environment with firewall restrictions:

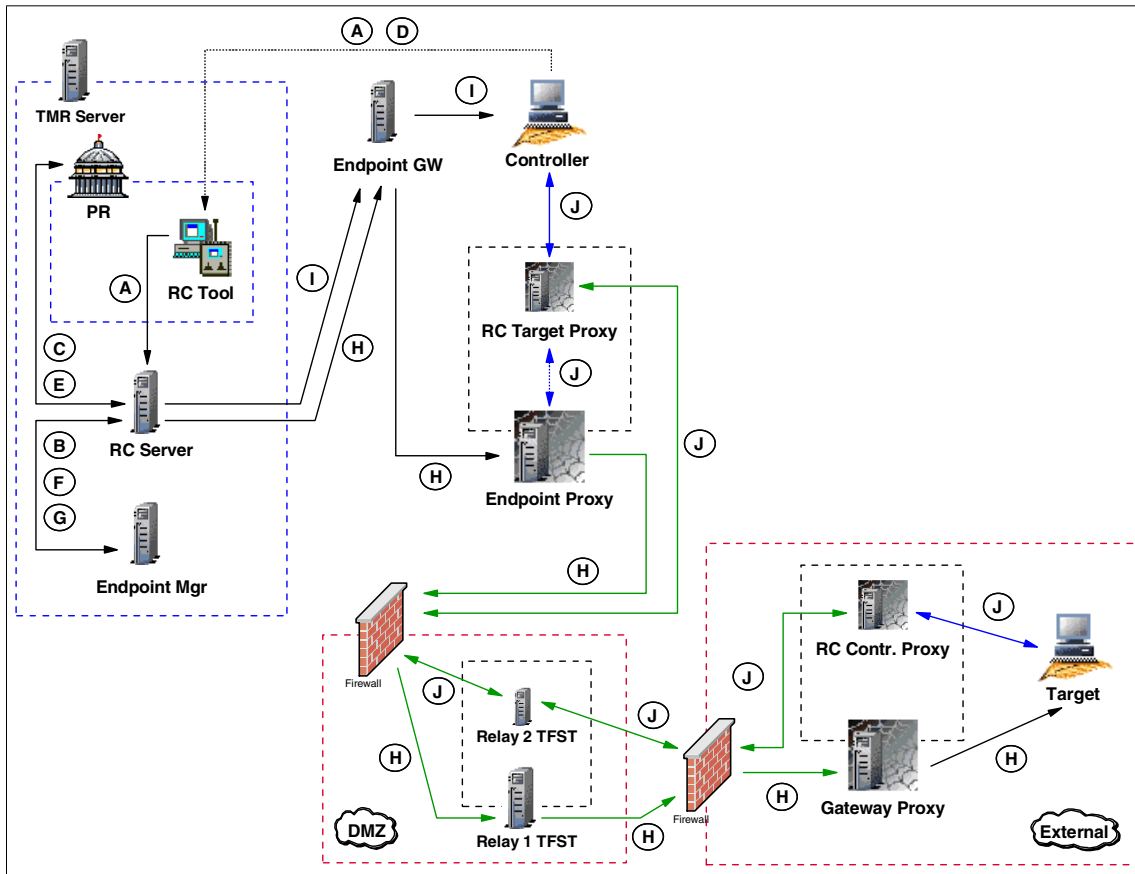

Figure 1-8 RC session data flow in an RC Proxy-TFST/single-TMR environment

Based on Figure 1-8, here we detail each step from the time the Tivoli Administrator opens a Remote Control Tool until the connection is established between the Controller and the Target through the Remote Control Proxies.

The legend used in Figure 1-8 is explained as follows:

Steps **A, B, C, D, E, F, G** and **I** remain the same as for a Remote Control session in single-TMR environment without firewall restriction. Refer to “Data flow for single-TMR session” on page 14 for detailed information about these steps.

The remaining steps are different and are defined as follows:

- H** This step remains almost the same as for a standard session in a non-secure environment. However, in a standard process the `nd_start_target` method is sent to the Target using the standard

Endpoint Communication Protocol packets. In a TFST environment, these packets are encapsulated by the Endpoint Proxy inside common HTTP packets. HTTP protocol has been chosen, as it is “firewall friendly” protocol. The packets are then rebuilt into Tivoli proprietary communication protocol by the Gateway proxy to let the distant Targets understand the order to start an RC session.

When the request arrives from the standard Tivoli environment, it contains the label of the distant Endpoint, which is the Target in this case. The Endpoint Proxy owns its proper Endpoint Database where key information about each distant Endpoint is stored and notably its Gateway Proxy. Using this information, the Endpoint Proxy is able to forward the request to the correct Gateway Proxy, which will forward it at the end to the Endpoint.

In the situation depicted in Figure 1-8 on page 46, there are two firewalls separating the standard Tivoli environment from the distant Endpoints. To let the Endpoint Proxy, which needs to be on the same network zone that the Tivoli Endpoint Gateway, communicate with the Gateway Proxy, which needs to be close to the distant Endpoints, a second instance of the Relay is needed in the zone between the firewalls. Its role is just to forward the packets to the final destination between the different network zones. Multiple Relays could be chained to cross multiple secure zones.

**J** Both sessions on the Target and on the Controller are now started. At this step, the Controller needs to establish the link to control the Target. The `rc_def_proxy` policy has been configured to force the usage of the Remote Control Proxies and the Remote Control Server has been informed of that on step **E**. The Remote Control server then has informed the Controller (step **I**) to use the RC Target Proxy in order to contact the Target. The Controller is able now to transfer the connection request to the RC Target Proxy.

As only the RC Target Proxy port is defined in the `rc_def_proxy` policy in an auto mode, the Controller only receives the address of the Endpoint Proxy. As the RC Target Proxy must be installed on the same machine as the Endpoint Proxy, the Controller can forward the Target request to the RC Target Proxy using the address of the Endpoint Proxy.

When the Target Proxy receives the request, it needs to find which RC Controller Proxy the Endpoint is attached to. In a Tivoli Firewall Security Toolbox environment, the Endpoint Proxy is in charge to manage the key information of the Endpoint. To know the right path to contact the Target, the RC Target Proxy needs to ask the Endpoint Proxy for this information. The Endpoint Proxy provides the host

name of the Gateway Proxy which the Target is connected to. As the RC Controller Proxy must be installed on the same machine as the Gateway Proxy, the RC Target proxy is able to connect to this RC Controller Proxy and forward the Target request using the Gateway Proxy IP Address provided by the Endpoint Proxy. The RC Controller Proxy then uses the Target information stored in the first request to start a session with the Target.

The Remote Control session is now established. It is important to notice that once the session established, the Controller talks directly with the Target, but it's *not* a peer-to-peer communication (Controller-Target) anymore, as the communication flow must always go through the Remote Control Proxies.

The Target is listening on port defined in the `rc_def_ports` policy. On the Controller side, by default, the port is assigned by the communication stack. However, these ports could be easily changed by configuring the `rc_def_ports` Remote Control Policies. The RC Target Proxy and the RC Controller Proxy are listening on the port defined during the installation process. The port specified in the `rc_def_proxy` policy must be the same as defined during the installation process of the RC Target Proxy. The configuration of these RC Proxies ports could be reviewed by editing the `rcproxy.cfg` configuration file. However, if you decided to change this port, you need to also review the `rc_def_proxy` policy. For more information about the RC Proxies configuration files, refer to *IBM Tivoli Remote Control User's Guide, SC23-4842*.

In the scenario depicted in Figure 1-8 on page 46, there are two firewalls separating the standard Tivoli environment from the distant Endpoints. To let the RC Target Proxy, which needs to be on the same network zone that the Controller, communicate with the RC Controller Proxy, which needs to be close to the Target, a second instance of a Relay is needed. Its role is just to forward the packet to the final destination between the different network zones. Multiple Relays could be chained to cross all multiple secure zones. The Relay is not a Remote Control Component, it is a Tivoli Firewall Security Toolbox one. In fact, one instance of the Relay is needed to manage network flow between the Endpoint Proxy and Gateway Proxy and another instance of the same Relay need to be installed on the same machine as the first Relay instance to manage the network flow between the Remote Control Proxies.

In order to implement the Remote Control session to use Remote Control Proxies, the `rc_def_proxy` default policy method needs to be configured, for instance, as shown in Example 1-18.

*Example 1-18 The rc\_def\_proxy default policy method for Remote Control*

---

```
#!/bin/sh
#
# Default policy method for Remote Control Proxy
#
# This policy method determines whether to use Remote Control Proxies.
# If you use Remote Control Proxies, rc_def_proxy defines how the controller
# uses the Remote Control Proxies to start a session with a target across a
# firewall.
#
# Possible values:
#
# NO      Do not use the Remote Control Proxies.
#
# YES <configuration type> <rc proxy ip address> <rc proxy port>
#       Use the Remote Control Proxies, where:
#
#       <configuration type>
#           Identifies the following scenarios:
#
#           auto
#           The controller and Remote Control Proxies
#           search the route to the target using the
#           information stored by
#           Tivoli Firewall Security Toolbox.
#
#           manual
#           The Remote Control Proxies run as standalone.
#           The controller uses the network address that
#           you specify in this method to reach
#           the machine where the target
#           proxy runs.
#
#       <rc proxy ip address>
#           Identifies the machine where the target proxy
#           runs. You must use this parameter only with
#           the manual configuration type.
#
#       <rc proxy port>
#           Identifies the port that the target proxy uses to
#           communicate with the controller or the controller
#           proxy.
#
# Default value: NO
#
# Examples follow.
#
```

```
# First example:
#   YES manual 192.168.100.50 3501
#
# Second example:
#   YES auto 3501
#
# Third example:
#   NO
#
```

```
echo "YES auto 5020"
```

```
exit 0
```

---

### **Data flow for RC Proxy-TFST/multi-TMR session**

Figure 1-9 shows in detail how a Remote Control session works using a Remote Control Proxy - TFST architecture in a multi-TMR environment with firewall restrictions:

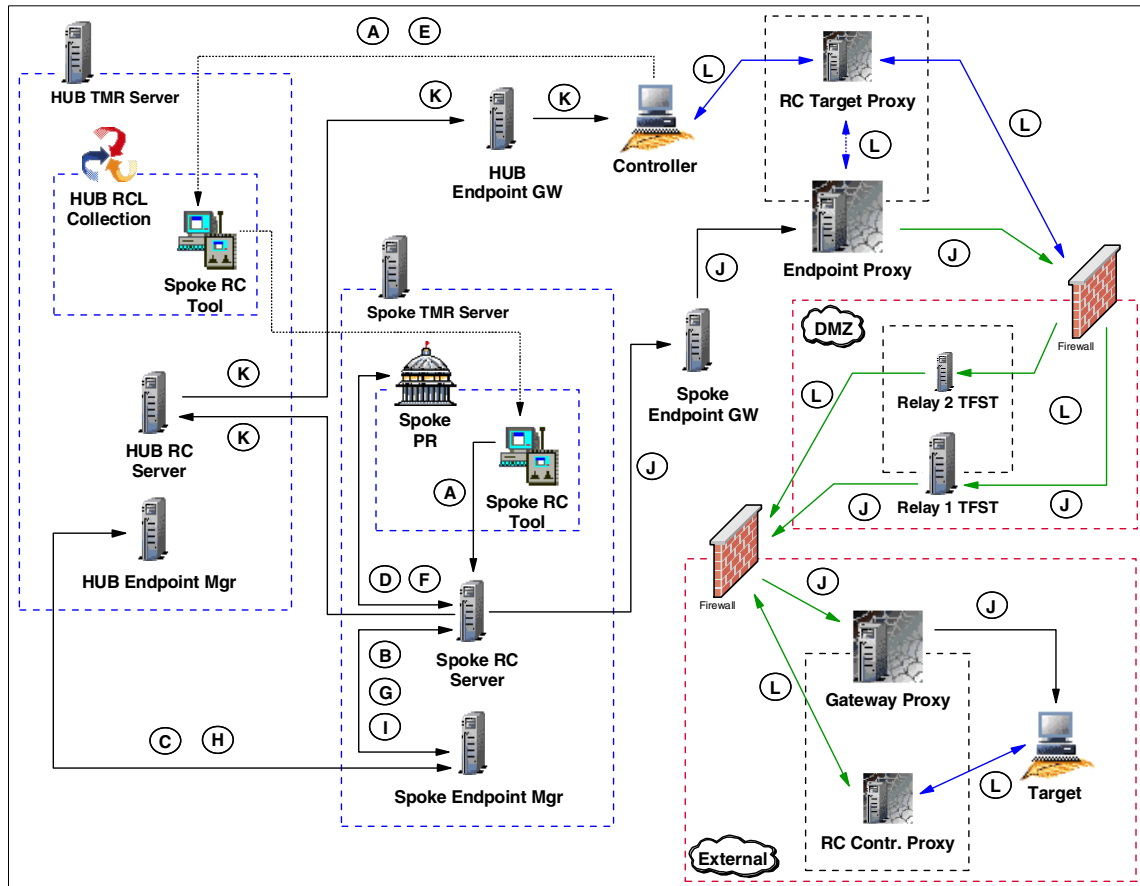

Figure 1-9 RC session data flow in an RC Proxy-TFST/multi-TMR environment

Based on Figure 1-9, here we detail each step from the time the Tivoli Administrator opens a Remote Control Tool until the connection is established between the Controller and the Target through the Remote Control Proxies.

The legend used in Figure 1-9 is explained as follows:

Steps **A, B, C, D, E, F, G, H, I** and **K** remain the same as for a Remote Control session in a multi-TMR environment without firewall restriction. Refer to “Data flow for a multi-TMR session” on page 21 for detailed information about these steps.

The remaining steps are different and are defined as follows:

- J** This step remains almost the same as for a standard session in a non-secure environment. However, in a standard process, the

nd\_start\_target method is sent to the Target using the standard Endpoint Communication Protocol packets. In a TFST environment, these packets are encapsulated by the Endpoint Proxy inside common HTTP packets. HTTP protocol has been chosen, as it is considered a “firewall friendly” protocol. The packets are then rebuilt into Tivoli proprietary protocol by the Gateway proxy to let the distant Targets understand the order to start an RC session.

When the request arrives from the standard Tivoli environment, it contains the label of the distant Endpoint, which is the Target in this case. The Endpoint Proxy owns its proper Endpoint Database where key information about each distant Endpoint is stored and notably its Gateway Proxy. Using this information, the Endpoint Proxy is able to forward the request to the right Gateway Proxy which will forward it at the end to the Endpoint.

In the situation depicted in Figure 1-9 on page 51, there are two firewalls separating the standard Tivoli environment from the distant Endpoints. To let the Endpoint Proxy (which needs to be on the same network zone as the Tivoli Endpoint Gateway) communicate with the Gateway Proxy (which needs to be close to the distant Endpoints), a second instance of the Relay is needed in the zone between the firewalls. Its role is just to forward the packets to the final destination between the different network zones. Multiple Relays could be chained to cross multiple secure zones.

**L** Both sessions on the Target and on the Controller are now started. At this step, the Controller need to establish the link to control the Target. The rc\_def\_proxy policy has been configured to force the usage of the Remote Control Proxies and the Remote Control Server has been informed of that on step I. The Remote Control server then has informed the Controller (step K) to use the RC Target Proxy in order to contact the Target. The Controller is able now to transfer the connection request to the RC Target Proxy.

As only the RC Target Proxy port is defined in the rc\_def\_proxy policy in an auto mode, the Controller only receives the address of the Endpoint Proxy. As the RC Target Proxy must be installed on the same machine as the Endpoint Proxy, the Controller can forward the Target request to the RC Target Proxy using the address of the Endpoint Proxy.

When the Target Proxy receives the request, it needs to find on which RC Controller Proxy the Endpoint is attached to. In a TFST environment, the Endpoint Proxy is in charge to manage the key information of the Endpoint. To know the right path to contact the Target, the RC Target Proxy needs to ask the Endpoint Proxy for this information. The Endpoint Proxy provides the host name of the



Gateway Proxy on which the Target is connected to. As the RC Controller Proxy must be installed on the same machine as the Gateway Proxy, the RC Target proxy is able to connect to this RC Controller Proxy and forward the Target request using the Gateway Proxy Address provided by the Endpoint Proxy. The RC Controller Proxy uses the Target information stored in the first request to start a session with the Target.

The Remote Control session is now established. It is important to notice that once the session established, the Controller talks directly with the Target, but it's NOT a peer-to-peer communication (Controller-Target) anymore, as the communication flow must always go through the Remote Control Proxies.

The Target is listening on port define in the `rc_def_port` policy. On the Controller side, by default, the port is assigned by the communication stack. However, these ports could be easily changed by configuring the `rc_def_ports` Remote Control Policies. The RC Target Proxy and the RC Controller proxy are listening on the port defined during the installation process. The port specified in the `rc_def_proxy` policy must be the same as defined during the installation process of the RC Target Proxy. The configuration of these RC Proxies port could be reviewed by editing the `rcproxy.cfg` configuration file. However, if you decided to change this port, you need to also review the `rc_def_proxy` policy. For more information about the RC Proxies configuration files, refer to *IBM Tivoli Remote Control User's Guide, SC23-4842*.

In the situation depicted in Figure 1-9 on page 51, there are two firewalls separating the standard Tivoli environment from the distant Endpoints. To let the RC Target Proxy (which needs to be on the same network zone as the Controller) communicate with the RC Controller Proxy (which needs to be close to the Target), a second instance of the Relay is needed. Its role is just to forward the packet to the final destination between the different network zones. Multiple Relays could be chained to cross all multiple secure zones. The Relay is not a Remote Control Component, it is a Tivoli Firewall Security Toolbox one. In fact, one instance of the Relay is needed to manage network flow between the Endpoint Proxy and Gateway Proxy and another instance of the same Relay need to be installed on the same machine as the first Relay instance to manage the network flow between the Remote Control Proxies.

In order to implement the Remote Control session to use Remote Control Proxies, the `rc_def_proxy` default policy method needs to be configured as shown in Example 1-18 on page 49. This has to be done in the Spoke TMR where the Remote Control Object is located.

## Tracing for RC Proxy-TFST

The methods used to start a session in a Remote Control Proxy-TFST architecture are the same that are used to start a session in a non-secure environment. Refer to Example 1-1 on page 16 for a subset of an IBM Tivoli Management Framework `odstat` command output for a single-TMR architecture; and to Example 1-6 on page 25 and Example 1-7 on page 25 for multi-TMR architecture.

In “Tracing for single-TMR session” on page 16 and “Tracing for a multi-TMR session” on page 24, we provided the detail of the most important methods used to start a Remote Control session both in a single-TMR and multi-TMR architecture. As mentioned, the methods are almost the same to start a Remote Control session in a secure environment. Thus, we only provide in this section the main differences for the most important methods.

The Target request, managed by the `remote_control` method, remains the same in a secure environment. For more information about this method, refer to Example 1-2 on page 19 for a single-TMR architecture and to Example 1-8 on page 28 for a multi-TMR architecture.

The Example 1-19 details the `is_proxied_ep` method started from either the TMR Server in a single-TMR architecture or from the Spoke TMR Server in a multi-TMR architecture. It refers to the following line in Example 1-7 on page 25:

```
1380596993.12.522+#TMF_Endpoint::Endpoint# is_proxied_ep
```

This method checks if the Target is behind an Endpoint Proxy/Gateway Proxy architecture. If the result is `true`, Remote Control knows that an Endpoint Proxy must be used to contact the Target. We see that the result of this method is `true`; this means that the Target is an Endpoint connected to a Gateway Proxy.

*Example 1-19 The `is_proxied_ep` method for an RC Proxy-TFST architecture*

---

```
loc-oc 11620                               9
  Results: (encoded):
          true
```

---

Example 1-20 details the `nd_start_target` method started from either the TMR Server in a single-TMR architecture or from the Spoke TMR Server in a multi-TMR architecture. It refers to the following line in Example 1-7 on page 25:

```
1380596993.12.522+#TMF_Endpoint::Endpoint# nd_start_target
```

This method is used to start the local Remote Control process on the Target. A return code of 0; this means that the session starts without error.

*Example 1-20 The nd\_start\_target method for an RC Proxy-TFST architecture*

---

```
loc-oc 11621                               23
  Results: (encoded):
    "" 0
```

---

Example 1-21 details the `nd_start_controller` method started from the Spoke TMR Server in a multi-TMR architecture and it shows more useful information to understand how the information about the Target Proxy is passed to the Controller. It refers to the following line in Example 1-7 on page 25:

```
1380596993.7.522+#TMF_Endpoint::Endpoint# nd_start_controller
```

This method is used to start the local Remote Control process on the Controller.

As a reference, the following information is needed to interpret Example 1-21.

- ▶ The Target IP address is 9.3.5.29
- ▶ The Controller IP address is 9.3.4.244
- ▶ As the Target Proxy is installed on the same machine as the Endpoint Proxy, the Controller doesn't need this to know the Target Proxy IP address.

The 5020 number, in fact, is the port number on which the Target Proxy is listening. This port is defined in the `rc_def_proxy` Policy. The return code of this method is 0; this means that the session starts without error.

*Example 1-21 The nd\_start\_controller method for an RC Proxy-TFST architecture*

---

```
rem-ic 11625   M-H 1-11608   227
  Time run:    [Thu 30-Jan 18:34:04]

Object ID:    1519322503.35.522+#TMF_Endpoint::Endpoint#
Method:       nd_start_controller
Principal:    root@tic01002 (0/0)
Path:
Input Data: (encoded):
  "\tivoli\pcremote\eqnrsmi.exe"
  {
  1
  [
  "/I9.3.5.29 /
  ],
  ,(?!?+;
  ]
  /Ntic01007 /
  ],
  ,(?!?+;
  ]
  /C5020 /E /B12 /M /T /
```

```
    ]
    ;+?!((,,
  ]
  /HRoot_tic01002-region(root@tic01002) /
]
;+?!((,,
]
"
]
}
65540 "9.3.4.244"

rem-oc 11625                               12
      Results: (encoded):
            0
```

---



## Implementation planning

In this chapter we provide considerations to ensure an effective implementation of IBM Tivoli Remote Control (ITRC) within environments across an enterprise protected by firewalls.

IBM Tivoli Remote Control is dependent on a number of requirements and supporting applications as the network constraints, the enterprise IT security policies, the Tivoli Management Framework design and, in some situations, the Tivoli Firewall Security Toolbox configuration, which make planning an essential task in order to ensure a successful deployment.

Before implementing IBM Tivoli Remote Control in secured areas, you need to consider the design of your network topology and analyze all technical, network, and security requirements. This should include a Remote Control physical design in order to place all IBM Tivoli Remote Control components efficiently, and a Remote Control Logical design in order to configure all required Remote Control policies and roles. You should also consider the hardware and software requirements and their dependencies on the various functional pieces of the other applications that support the IBM Tivoli Remote Control solution.

The main topics concerning planning discussions in this chapter are:

- ▶ Considerations regarding the Remote Control design
- ▶ Planning for IBM Tivoli Remote Control
- ▶ Case study scenarios of IBM Tivoli Remote Control implementation planning

## 2.1 Design

In this section we address design considerations for the implementation of IBM Tivoli Remote Control in a secure environment. In fact, we assume that the Tivoli environment is already deployed within the enterprise. Thus, no information on planning for the IBM Tivoli Management Framework and the Tivoli Firewall Security Toolbox is provided in this section. For more information about the IBM Tivoli Management Framework architecture, refer to the *Tivoli Management Framework Planning for Deployment Guide*, GC32-0803, and for more information about the Tivoli Firewall Security Toolbox architecture, refer to the *Firewall Security Toolbox User's Guide*, GC23-4826.

Furthermore, as the main topic of this book is to describe IBM Tivoli Remote Control in a firewall environment, this section focuses more on the IBM Tivoli Remote Control Proxy planning considerations than on the whole picture of IBM Tivoli Remote Control planning. You can get more information about architecture considerations and configuration for a standard IBM Tivoli Remote Control environment in the *IBM Tivoli Remote Control User's Guide*, SC23-4842.

We should also point out that we will not cover planning for the Remote Control component, as the Remote Control Proxies provide a better technology and are more flexible in responding to all security constraints an enterprise may have.

### 2.1.1 Logical design

In order to force the RC Controller to use an RC Target Proxy, some specific Remote Control policies need to be configured. This means that a new Logical structure must be defined for each secure environment served by a different RC Target-Controller Proxy architecture.

In order to satisfy this requirement, and because the Remote Control object is a Tivoli managed resource, a new Policy Region must be created to host the new Remote Control Tool (RC Tool) object. This RC Tool will manage the list of Targets for a specific secure zone served by the same RC Target Proxy. All RC Tools created in this Policy Region will respond to the same set of RC policies as they apply to a Policy Region and not to a specific RC Object. You should create as many Policy Regions as RC Target-Controller Proxy architectures you plan to have.

The main RC policies that need be reviewed for a secure environment are:

- ▶ `rc_def_proxy`: Defines whether to use Remote Control Proxies or not.
- ▶ `rc_def_ports`: Defines the ports to use for Controller-Target communications.
- ▶ `rc_def_encryption`: Defines data encryption using DES method.

The remaining RC Policies should follow the same rules defined for all other RC Objects. They don't have a direct impact on the way IBM Tivoli Remote Control works across firewalls. However, they could also be reviewed in order to fulfill some new requirements concerning the type of actions (for example, Remote Control, File Transfer, or Chat) that a Tivoli Administrator is able to use in a secure environment.

For more information about how to configure the Remote Control policies, refer to the *IBM Tivoli Remote Control User's Guide, SC23-4842*.

If you have defined the Administrator Roles at the Resource level rather than at the TMR level, you need to assign the Remote Control roles for the new Policy Regions hosting the new Remote Control Objects to the Administrator.

## 2.1.2 Physical design

This section addresses the Physical design for the implementation of IBM Tivoli Remote Control across firewalls. The Physical design develops the underlying physical infrastructure on which the solution will operate. Sufficient time needs to be allocated to ensure that the correct design has been developed because when deployed and operational, the Physical design may be difficult to change without a disruption of the IBM Tivoli Remote Control environment or, at worst, a disruption of the entire Tivoli infrastructure.

Before defining where the different components of the IBM Tivoli Remote Control Proxy — and, if necessary, the TFST components — should be installed, you first need to identify and determine the existing firewall environment as well as the architecture and all the restrictions that these firewalls impose on your IBM Tivoli Remote Control environment. In addition, the placement of all the other IBM Tivoli Remote Control components (such as RC Controllers and Targets) needs to be identified, especially which network zone they are located in.

As explained in 1.2, “IBM Tivoli Remote Control sessions overview” on page 12, the scenarios supported by IBM Tivoli Remote Control can be divided into two categories corresponding to the firewall placement:

1. Scenarios where a Tivoli Endpoint Gateway is installed in the same secure network zone as the Targets, and the Controllers are located in another network zone managed by another Tivoli Endpoint Gateway. In this case, the IBM Tivoli Remote Control Proxy could be installed as a **Standalone** solution, as the Tivoli Firewall Security Toolbox does not need to be deployed. However, this means that Targets and/or Controllers are separated from their TMR Server by one firewall.

2. Scenarios where the Targets and/or Controllers are separated from their standard Tivoli Endpoint Gateway by a firewall. In this case, a Tivoli Firewall Security Toolbox is needed to manage these Endpoints. IBM Tivoli Remote Control must be installed on top of the Tivoli Firewall Security Toolbox architecture in order for it to be able to contact the Endpoint separated from their TMR Server by, at least, one firewall or more. Such a solution is often referred to as a **Non-Standalone** or **RCProxy-TFST** solution.

At this point, you should know if an IBM Tivoli Remote Control Proxy Standalone solution or a Non-Standalone solution has to be deployed.

In a case of a Non-Standalone solution, you need to identify the placement of both the Endpoint Proxy and Gateway Proxy. If the RC Controller is in the same network zone as the Endpoint Proxy, the RC Target Proxy must be installed on top of the Endpoint Proxy (same physical machine). Similarly, the RC Controller Proxy must be installed on top of the Gateway Proxy. Otherwise, if the RC Controller is in the same network zone as the Gateway Proxy, the RC Target Proxy must be installed on top of the Gateway Proxy, and the RC Controller Proxy on top of the Endpoint Proxy.

However, if the intention is to have RC Controllers and RC Targets in both network zones (more secure and less secure), an RC Target Proxy and an RC Controller could be installed at the same time on top of the Endpoint Proxy and also on top of the Gateway Proxy. If one or many Relays are already installed to let the Endpoint Proxy communicate with the Gateway Proxy through more than one firewall, a new instance of the Relay needs to be installed on top of all Relays already installed (same physical machine) in order to permit the RC Proxies to communicate together through a dedicated channel.

In a case of a Standalone solution, if the RC Controller is in the same network zone as the TMR Server, the RC Target Proxy must be installed inside the more secure zone and the RC Controller Proxy in the less secure zone. Otherwise, if the RC Controller is in the less secure network zone, the RC Target Proxy must be installed in the less secure zone, and the RC Controller Proxy in the more secure zone. However, if you plan to have RC Controllers and RC Targets in both network zones (more secure and less secure), an RC Target Proxy and an RC Controller Proxy could be installed at the same time in the less secure and also in the more secure network zone.

In some situations, the RC Target Proxy needs to cross more than one firewall to contact the RC Controller Proxy. In this case, you must plan to use a Tivoli Firewall Security Toolbox Relay. This component is also able to transfer the RC Target Proxy information to the RC Controller Proxy information even in a Standalone solution.



Having decided where to place the different components, you need now to decide on the Parent-Child relationship. In other words, to define which one of the RC Target Proxy or the RC Controller Proxy must be the Parent and which one must be the Child. For more information about the Parent-Child concept, refer to the 1.1.4, “Parent-Child concept” on page 10.

Furthermore, in both Standalone and Non-Standalone solutions, you must get the security rules defined to manage these secure network zones from your enterprise Security Officer. These rules define which type of communication you will be able to use to cross the firewalls (bidirectional or unidirectional), and which network zone the communication could be initiated from. For more information about the different type of communication, refer to the 1.1.5, “Proxy connection types” on page 11.

As soon as you know which type of communication you are able to use, you need to define the Source and the Destination of the communication and, of course, the network ports that will be used to communicate. The following section provides a list of communication ports for either a bidirectional or unidirectional communications. This information should be discussed with the Security Officer and documented as new firewall policies within your enterprise standard Security documentation.

**Note:** The terms bidirectional and unidirectional communication can be misleading sometimes. In the context of this redbook, they refer to the communication initiation step. Unidirectional communication between two components means that the communication can only be initiated by one of the components. Bidirectional communication between two components means that the communication can be initiated by either one of the components.

### 2.1.3 Network considerations

IBM Tivoli Remote Control Proxies encapsulate the Tivoli proprietary protocol using the Hyper Text Transfer Protocol (HTTP) for communication.

When planning your IBM Tivoli Remote Control Proxy solution, you should take the following as considerations in order to improve RC Target Proxy and RC Controller Proxy networking performance:

- ▶ Introduce high-speed network adapters on all IBM Tivoli Remote Control Proxies.
- ▶ Use local file system storage for binaries, libraries and data.
- ▶ Place the RC Target Proxy and RC Controller Proxy in a high-speed segment so that it could faster serves the different requests.

Regarding the network communication for IBM Tivoli Remote Control, it is important to notice that the communication pipe between the RC Proxies is always opened and started as soon as the local RC Proxies services are started. If a Relay is part of the architecture, the communication pipes between the RC Proxies and the Relay are also always opened and started at the service startup time. The communication channels between the RC Controller and the RC Target Proxy and between the RC Target and the RC Controller Proxy are opened only when the remote session is started.

**Note:** The information provided in the following tables could be used to configure the filtering rules of the firewall.

**Note:** The following sections mainly provide information about the Remote Control Proxies network communication. These communications are the same even if the Remote Control Proxy is a Standalone or a Non-Standalone solution. However, the information provided could also help you to understand the network communication between an Endpoint Proxy and a Gateway Proxy, as the Proxy concept is almost the same for the both products. Furthermore, as the Proxy configuration files are the same, you could replace the RC Target Proxy by the Endpoint Proxy and the RC Controller Proxy by the Gateway Proxy in the sections below. However, you will find more information about the Endpoint Proxy/Gateway Proxy communication in the redbook, *Tivoli Enterprise Management Across Firewalls*, SG24-5510 .

**Note:** In order to better explain the different ports used by IBM Tivoli Remote Control, we assume that the RC Target Proxy is the Parent Proxy and that the RC Controller Proxy is the Child Proxy. However, the communications ports concept will work the same if the RC Target Proxy is installed on the Child Proxy and the RC Controller Proxy on the Parent Proxy.

### **Unidirectional communication without Relay**

Table 2-1 provides an exhaustive list of communication ports required to allow the RC Controller to communicate with the RC Target located in another network zone using a unidirectional communication type between the RC Proxies. In this situation, the Parent Proxy, which is the RC Target Proxy, is the *initiator*. The comments following the table refer to the numbered notes inside the table.

Table 2-1 RC ports for unidirectional communication - Parent/initiator

Source		Destination		Protocol	Description
Type (Service)	Port (Single / Range)	Type (Service)	Port (Single / Range)		
Controller (eqnrsmi)	random or defined <sup>1</sup> (single)	Target Proxy (rcproxy)	9494 <sup>2</sup> (single)	TCP	Started at request. Communication in the same network zone. No firewall rule needed.
Target Proxy (rcproxy)	random or defined <sup>3</sup> (single or range)	Controller Proxy (rcproxy)	defined <sup>4</sup> (single)	TCP	Started at service time. Communication between two network zones. <b>Firewall rule needed.</b> Default polling interval is 2 seconds <sup>5</sup> .
Controller Proxy (rcproxy)	random (single)	Target (eqnrcmai)	2501 <sup>6</sup> (single)	TCP	Started at request. Communication in the same network zone. No firewall rule needed.

Comments:

1. This port can be fixed in the *rc\_def\_ports* RC Policy.
2. This default port could be changed using the *proxy-port* parameter in the *[rcproxy]* section of the Parent *rcproxy.cfg* file, that in this case is the RC Target Proxy configuration file. This port must match with the port defined in the *rc\_def\_proxy* RC Policy.
3. This port or port range could be fixed by configuring the *local-port-range* parameter in the *[children-cm-info]* section of the Parent *rcproxy.cfg* file, in this case the RC Target Proxy configuration file.
4. This port must be configured using the *parent-local-port* parameter in the *[communication-layer]* section of the Child *rcproxy.cfg* file, in this case the RC Controller Proxy configuration file. This port must match with the port specified in the *children-remote-list* parameter in the *[communication-layer]* section of the Parent *rcproxy.cfg* file, in this case the RC Target Proxy configuration file.
5. The default polling interval could be changed by configuring the *polling-interval* parameter in the *[children-cm-info]* section of the Parent *rcproxy.cfg* file, in this case the RC Target Proxy configuration file, as it is the initiator.

6. This default port is for a Remote Control session and could be changed in the *rc\_def\_ports* RC Policy. The default port for a File Transfer session is 2502 and could also be changed in the *rc\_def\_ports* RC Policy.

For more information about how to configure the RC Policies or the Proxy configuration files, refer to the *IBM Tivoli Remote Control User's Guide*, SC23-4842.

Table 2-2 provides the same information as provided in Table 2-1 on page 63, but in this situation, the Parent Proxy, which is the RC Target Proxy, is the *listener*. The comments following the table refer to the numbered notes inside the table.

Table 2-2 RC ports for unidirectional communication - Parent/listener

Source		Destination		Protocol	Description
Type (Service)	Port (Single / Range)	Type (Service)	Port (Single / Range)		
Controller (eqnrsmi)	random or defined <sup>1</sup> (single)	Target Proxy (rcproxy)	9494 <sup>2</sup> (single)	TCP	Started at request. Communication in the same network zone. No firewall rule needed.
Controller Proxy (rcproxy)	random or defined <sup>3</sup> (single or range)	Target Proxy (rcproxy)	defined <sup>4</sup> (single)	TCP	Started at service time. Communication between two network zones. <b>Firewall rule needed.</b> Default polling interval is 2 seconds <sup>5</sup> .
Controller Proxy (rcproxy)	random (single)	Target (eqnrcmai)	2501 <sup>6</sup> (single)	TCP	Started at request. Communication in the same network zone. No firewall rule needed.

Comments:

1. This port could be fixed in the *rc\_def\_ports* RC Policy.
2. This default port could be changed using the *proxy-port* parameter in the *[rcproxy]* section of the Parent *rcproxy.cfg* file, in this case the RC Target Proxy configuration file. This port must be the same as defined in the *rc\_def\_proxy* RC Policy.
3. This port or port range could be fixed by configuring the *local-port-range* parameter in the *[parent-cm-info]* section of the Child *rcproxy.cfg* file, in this case the RC Controller Proxy configuration file.

4. This port must be configured using the *children-local-port* parameter in the *[communication-layer]* section of the Parent *rcproxy.cfg* file, in this case the RC Target Proxy configuration file. This port must be the same as specified in the *parent-remote-port* parameter in the *[communication-layer]* section of the Child *rcproxy.cfg* file, in this case the RC Controller Proxy configuration file.
5. The default polling interval could be changed by configuring the *polling-interval* parameter in the *[parent-cm-info]* section of the Child *rcproxy.cfg* file, in this case the RC Controller Proxy configuration file, as it is the initiator.
6. This default port is for a Remote Control session and could be changed in the *rc\_def\_ports* RC Policy. The default port for a File Transfer session is 2502 and could also be changed in the *rc\_def\_ports* RC Policy.

For more information about how to configure the RC Policies or the Proxy configuration files, refer to the *IBM Tivoli Remote Control User's Guide*, SC23-4842.

### Unidirectional communication with Relay

Table 2-3 describes the same type of communication as detailed in Table 2-1 on page 63, but a new element, a Relay, has been introduced between the two RC Proxies. In this situation, the Parent Proxies, which are the RC Target Proxy and the Relay towards the RC Controller Proxy, are the *initiators*. The comments following the table refer to the numbered notes inside the table.

Table 2-3 RC ports for unidirectional communication - Relay - Parents/initiators

Source		Destination		Protocol	Description
Type (Service)	Port (Single / Range)	Type (Service)	Port (Single / Range)		
Controller (eqnrsmi)	random or defined <sup>1</sup> (single)	Target Proxy (rcproxy)	9494 <sup>2</sup> (single)	TCP	Started at request. Communication in the same network zone. No firewall rule needed.
Target Proxy (rcproxy)	random or defined <sup>3</sup> (single or range)	Relay (Relay)	defined <sup>4</sup> (single)	TCP	Started at service time. Communication between two network zones. <b>Firewall rule needed.</b> Default polling interval is 2 seconds <sup>5</sup> .

Source		Destination		Protocol	Description
Type (Service)	Port (Single / Range)	Type (Service)	Port (Single / Range)		
Relay (ReLay)	random or defined <sup>6</sup> (single or range)	Controller Proxy (rcproxy)	defined <sup>7</sup> (single)	TCP	Started at service time. Communication between two network zones. <b>Firewall rule needed.</b> Default polling interval is 2 seconds <sup>8</sup> .
Controller Proxy (rcproxy)	random (single or range)	Target (eqnrcmai)	2501 <sup>9</sup> (single)	TCP	Started at request. Communication in the same network zone. No firewall rule needed.

Comments:

1. This port could be fixed in the *rc\_def\_ports* RC Policy.
2. This default port could be changed using the *proxy-port* parameter in the *[rcproxy]* section of the Parent *rcproxy.cfg* file, in this case the RC Target Proxy configuration file. This port must be the same as defined in the *rc\_def\_proxy* RC Policy.
3. This port or port range could be fixed by configuring the *local-port-range* parameter in the *[children-cm-info]* section of the Parent *rcproxy.cfg* file, in this case the RC Target Proxy configuration file.
4. This port must be configured using the *parent-local-port* parameter in the *[communication-layer]* section of the Relay *Relay.cfg* file. This port must be the same as specified in the *children-remote-list* parameter in the *[communication-layer]* section of the Parent *rcproxy.cfg* file, in this case the RC Target Proxy configuration file.
5. The default polling interval could be changed by configuring the *polling-interval* parameter in the *[children-cm-info]* section of the Parent *rcproxy.cfg* file, in this case the RC Target Proxy configuration file, as it is the initiator.
6. This port or port range could be fixed by configuring the *local-port-range* parameter in the *[children-cm-info]* section of the Relay *Relay.cfg* file.
7. This port must be configured in the *parent-local-port* parameter in the *[communication-layer]* section of the Child *rcproxy.cfg* file, in this case the RC Controller Proxy configuration file. This port must be the same as specified in the *children-remote-list* parameter in the *[communication-layer]* section of the Parent *rcproxy.cfg* file, in this case the RC Target Proxy configuration file.

8. The default polling interval could be changed by configuring the *polling-interval* parameter in the [*children-cm-info*] section of the Relay *Relay.cfg* file, as it is the initiator.
9. This default port is for a Remote Control session and could be changed in the *rc\_def\_ports* RC Policy. The default port for a File Transfer session is 2502 and could also be changed in the *rc\_def\_ports* RC Policy.

For more information about how to configure the RC Policies or the Proxy configuration files, refer to the *IBM Tivoli Remote Control User's Guide*, SC23-4842.

Table 2-4 provides the same information as given in Table 2-3 on page 65, but in this situation, the Parent Proxies, which are the RC Target Proxy and the Relay towards the RC Controller Proxy, are the *listeners*. The comments following the table refer to the numbered notes inside the table.

Table 2-4 RC ports for unidirectional communication - Relay - Parents/listeners

Source		Destination		Protocol	Description
Type (Service)	Port (Single / Range)	Type (Service)	Port (Single / Range)		
Controller (eqnrsmi)	random or defined <sup>1</sup> (single)	Target Proxy (rcproxy)	9494 <sup>2</sup> (single)	TCP	Started at request. Communication in the same network zone. No firewall rule needed.
Relay (Relay)	random or defined <sup>3</sup> (single or range)	Target Proxy (rcproxy)	defined <sup>4</sup> (single)	TCP	Started at service time. Communication between two network zones. <b>Firewall rule needed.</b> Default polling interval is 2 seconds <sup>5</sup> .
Controller Proxy (rcproxy)	random or defined <sup>6</sup> (single or range)	Relay (Relay)	defined <sup>7</sup> (single)	TCP	Started at service time. Communication between two network zones. <b>Firewall rule needed.</b> Default polling interval is 2 seconds <sup>8</sup> .
Controller Proxy (rcproxy)	random (single or range)	Target (eqnrsmi)	2501 <sup>9</sup> (single)	TCP	Started at request. Communication in the same network zone. No firewall rule needed.

Comments:

1. This port could be fixed in the *rc\_def\_ports* RC Policy
2. This default port could be changed using the *proxy-port* parameter in the *[rcproxy]* section of the Parent *rcproxy.cfg* file, in this case the RC Target Proxy configuration file. This port must be the same as defined in the *rc\_def\_proxy* RC Policy.
3. This port or port range could be fixed by configuring the *local-port-range* parameter in the *[parent-cm-info]* section of the Relay *Relay.cfg* file.
4. This port must be configured using the *children-local-port* parameter in the *[communication-layer]* section of the Parent *rcproxy.cfg* file, in this case the RC Target Proxy configuration file. This port must be the same as specified in the *parent-remote-port* parameter in the *[communication-layer]* section of the Child *rcproxy.cfg* file, in this case the Relay configuration file.
5. The default polling interval could be changed by configuring the *polling-interval* parameter in the *[parent-cm-info]* section of the Relay *Relay.cfg* file, as it is the initiator.
6. This port or port range could be fixed by configuring the *local-port-range* parameter in the *[parent-cm-info]* section of the Child *rcproxy.cfg* file, in this case the RC Controller Proxy configuration file.
7. This port must be configured using the *children-local-port* parameter in the *[communication-layer]* section of the Relay *Relay.cfg* file. This port must be the same as specified in the *parent-remote-port* parameter in the *[communication-layer]* section of the Child *rcproxy.cfg* file, in this case the RC Controller Proxy configuration file.
8. The default polling interval could be changed by configuring the *polling-interval* parameter in the *[parent-cm-info]* section of the Child *rcproxy.cfg* file, in this case the RC Controller Proxy configuration file, as it is the initiator.
9. This default port is for a Remote Control session and could be changed in the *rc\_def\_ports* RC Policy. The default port for a File Transfer session is 2502 and could also be changed in the *rc\_def\_ports* RC Policy.

For more information about how to configure the RC Policies or the Proxy configuration files, refer to the *IBM Tivoli Remote Control User's Guide*, SC23-4842.



**Note:** A Relay could, at the same time, be an initiator and a listener, as it is a Child towards the RC Target Proxy and a Parent towards the RC Controller Proxy in our scenario. The information provided in the Table 2-3 on page 65 and Table 2-4 on page 67 can help you to understand all scenarios.

If the Relay is a Child listener and a Parent listener, get the Child listener communication ports in Table 2-3 on page 65 and the Parent listener ports in Table 2-4 on page 67. Conversely, if the Relay is a Child initiator and a Parent initiator, get the Child initiator communication ports in Table 2-4 on page 67 and the Parent initiator communication ports in Table 2-3 on page 65.

## Bidirectional communication without Relay

Table 2-5 provides an exhaustive list of communication ports required to allow the RC Controller to communicate with the RC Target located in another network zone using a bidirectional communication type between the RC Proxies. The comments following the table refer to the numbered notes inside the table.

Table 2-5 RC ports for bidirectional communication

Source		Destination		Protocol	Description
Type (Service)	Port (Single / Range)	Type (Service)	Port (Single / Range)		
Controller (eqnrsmi)	random or defined <sup>1</sup> (single)	Target Proxy (rcproxy)	9494 <sup>2</sup> (single)	TCP	Started at request. Communication in the same network zone. No firewall rule needed.
Target Proxy (rcproxy)	random or defined <sup>3</sup> (single or range)	Controller Proxy (rcproxy)	defined <sup>4</sup> (single)	TCP	Started at service time. Communication between two network zones. <b>Firewall rule needed.</b>
Controller Proxy (rcproxy)	random or defined <sup>5</sup> (single or range)	Target Proxy (rcproxy)	defined <sup>6</sup> (single)	TCP	Started at service time. Communication between two network zones. <b>Firewall rule needed.</b>
Controller Proxy (rcproxy)	random (single)	Target (eqnrcmai)	2501 <sup>7</sup> (single)	TCP	Started at request. Communication in the same network zone. No firewall rule needed.

Comments:

1. This port could be fixed in the *rc\_def\_ports* RC Policy
2. This default port could be changed using the *proxy-port* parameter in the *[rcproxy]* section of the Parent *rcproxy.cfg* file, in this case the RC Target Proxy configuration file. This port must be the same as defined in the *rc\_def\_proxy* RC Policy.
3. This port or port range could be fixed by configuring the *local-port-range* parameter in the *[children-cm-info]* section of the Parent *rcproxy.cfg* file, in this case the RC Target Proxy configuration file.
4. This port must be configured using the *parent-local-port* parameter in the *[communication-layer]* section of the Child *rcproxy.cfg* file, in this case the RC Controller Proxy configuration file. This port must be the same as specified in the *children-remote-list* parameter in the *[communication-layer]* section of the Parent *rcproxy.cfg* file, in this case the RC Target Proxy configuration file.
5. This port or port range could be fixed by configuring the *local-port-range* parameter in the *[parent-cm-info]* section of the Child *rcproxy.cfg* file, in this case the RC Controller Proxy configuration file.
6. This port must be configured using the *children-local-port* parameter in the *[communication-layer]* section of the Parent *rcproxy.cfg* file, in this case the RC Target Proxy configuration file. This port must be the same as specified in the *parent-remote-port* parameter in the *[communication-layer]* section of the Child *rcproxy.cfg* file, in this case the RC Controller Proxy configuration file.
7. This default port is for a Remote Control session and could be changed in the *rc\_def\_ports* RC Policy. The default port for a File Transfer session is 2502 and could also be changed in the *rc\_def\_ports* RC Policy.

For more information about how to configure the RC Policies or the Proxy configuration files, refer to the *IBM Tivoli Remote Control User's Guide*, SC23-4842.

## **Bidirectional communication with Relay**

Table 2-6 describes the same type of communication as detailed in Table 2-5 on page 69, but a new element, a Relay, has been introduced between the two RC Proxies. The comments following the table refer to the numbered notes inside the table.

Table 2-6 RC ports for bidirectional communication with Relay

Source		Destination		Protocol	Description
Type (Service)	Port (Single / Range)	Type (Service)	Port (Single / Range)		
Controller (eqnrsmi)	random or defined <sup>1</sup> (single)	Target Proxy (rcproxy)	9494 <sup>2</sup> (single)	TCP	Started at request. Communication in the same network zone. No firewall rule needed.
Target Proxy (rcproxy)	random or defined <sup>3</sup> (single or range)	Relay (Relay)	defined <sup>4</sup> (single)	TCP	Started at service time. Communication between two network zones. <b>Firewall rule needed.</b>
Relay (Relay)	random or defined <sup>5</sup> (single or range)	Target Proxy (rcproxy)	defined <sup>6</sup> (single)	TCP	Started at service time. Communication between two network zones. <b>Firewall rule needed.</b>
Relay (Relay)	random or defined <sup>7</sup> (single or range)	Controller Proxy (rcproxy)	defined <sup>8</sup> (single)	TCP	Started at service time. Communication between two network zones. <b>Firewall rule needed.</b>
Controller Proxy (rcproxy)	random or defined <sup>9</sup> (single or range)	Relay (Relay)	defined <sup>10</sup> (single)	TCP	Started at service time. Communication between two network zones. <b>Firewall rule needed.</b>
Controller Proxy (rcproxy)	random (single)	Target (eqnrcmai)	2501 <sup>11</sup> (single)	TCP	Started at request. Communication in the same network zone. No firewall rule needed.

Comments:

1. This port could be fixed in the *rc\_def\_ports* RC Policy
2. This default port could be changed using the *proxy\_port* parameter in the *[rcproxy]* section of the Parent *rcproxy.cfg* file, in this case the RC Target Proxy configuration file. This port must be the same as defined in the *rc\_def\_proxy* RC Policy.
3. This port or port range could be fixed by configuring the *local-port-range* parameter in the *[children-cm-info]* section of the Parent *rcproxy.cfg* file, in this case the RC Target Proxy configuration file.

4. This port must be configured using the *parent-local-port* parameter in the *[communication-layer]* section of the Relay *Relay.cfg* file. This port must be the same as specified in the *children-remote-list* parameter in the *[communication-layer]* section of the Parent *rcproxy.cfg* file, in this case the RC Target Proxy configuration file.
5. This port or port range could be fixed by configuring the *local-port-range* parameter in the *[parent-cm-info]* section of the Relay *Relay.cfg* file.
6. This port must be configured using the *children-local-port* parameter in the *[communication-layer]* section of the Parent *rcproxy.cfg* file, in this case the RC Target Proxy configuration file. This port must be the same as specified in the *parent-remote-port* parameter in the *[communication-layer]* section of the Child *rcproxy.cfg* file, in this case the Relay configuration file.
7. This port or port range could be fixed by configuring the *local-port-range* parameter in the *[children-cm-info]* section of the Relay *Relay.cfg* file.
8. This port must be configured in the *parent-local-port* parameter in the *[communication-layer]* section of the Child *rcproxy.cfg* file, in this case the RC Controller Proxy configuration file. This port must be the same as specified in the *children-remote-list* parameter in the *[communication-layer]* section of the Parent *rcproxy.cfg* file, in this case the RC Target Proxy configuration file.
9. This port or port range could be fixed by configuring the *local-port-range* parameter in the *[parent-cm-info]* section of the Child *rcproxy.cfg* file, in this case the RC Controller Proxy configuration file.
10. This port must be configured using the *children-local-port* parameter in the *[communication-layer]* section of the Relay *Relay.cfg* file. This port must be the same as specified in the *parent-remote-port* parameter in the *[communication-layer]* section of the Child *rcproxy.cfg* file, in this case the RC Controller Proxy configuration file.
11. This default port is for a Remote Control session and could be changed in the *rc\_def\_ports* RC Policy. The default port for a File Transfer session is 2502 and could also be changed in the *rc\_def\_ports* RC Policy.

For more information about how to configure the RC Policies or the Proxy configuration files, refer to the *IBM Tivoli Remote Control User's Guide*, SC23-4842.

**Note:** A Relay could, at the same time, be a Parent of the RC Controller Proxy and Child of the RC Target Proxy in our scenario. This means that the communication between the Relay and the RC Target Proxy could be unidirectional and bidirectional between the Relay and the RC Controller Proxy. The tables provided in 2.1.3, “Network considerations” on page 61 can help you to understand all of the scenarios.

If the communication between the Relay and the RC Target or Controller Proxy is unidirectional, refer to “Unidirectional communication with Relay” on page 65. If the communication between the Relay and the RC Controller or Target Proxy is bidirectional, refer to “Bidirectional communication with Relay” on page 70.

## 2.2 Planning for IBM Tivoli Remote Control Proxy

As IBM Tivoli Remote Control Proxies require additional supporting applications, such as the Tivoli Management Framework and, optionally, the Tivoli Firewall Security Toolbox in an RC Proxy Non-Standalone environment, the entire installation process, including Tivoli installation and firewall configuration phases, is depicted in Figure 2-1 on page 74 and Figure 2-2 on page 75. However, in this section, we do not discuss the installation process for each of the pre-requisite application; instead we focus on the installation process for the IBM Tivoli Remote Control Proxies.

Figure 2-1 shows the entire installation process, which includes the supporting application and the required firewall configurations phases for an IBM Tivoli Remote Control Proxy Standalone environment.

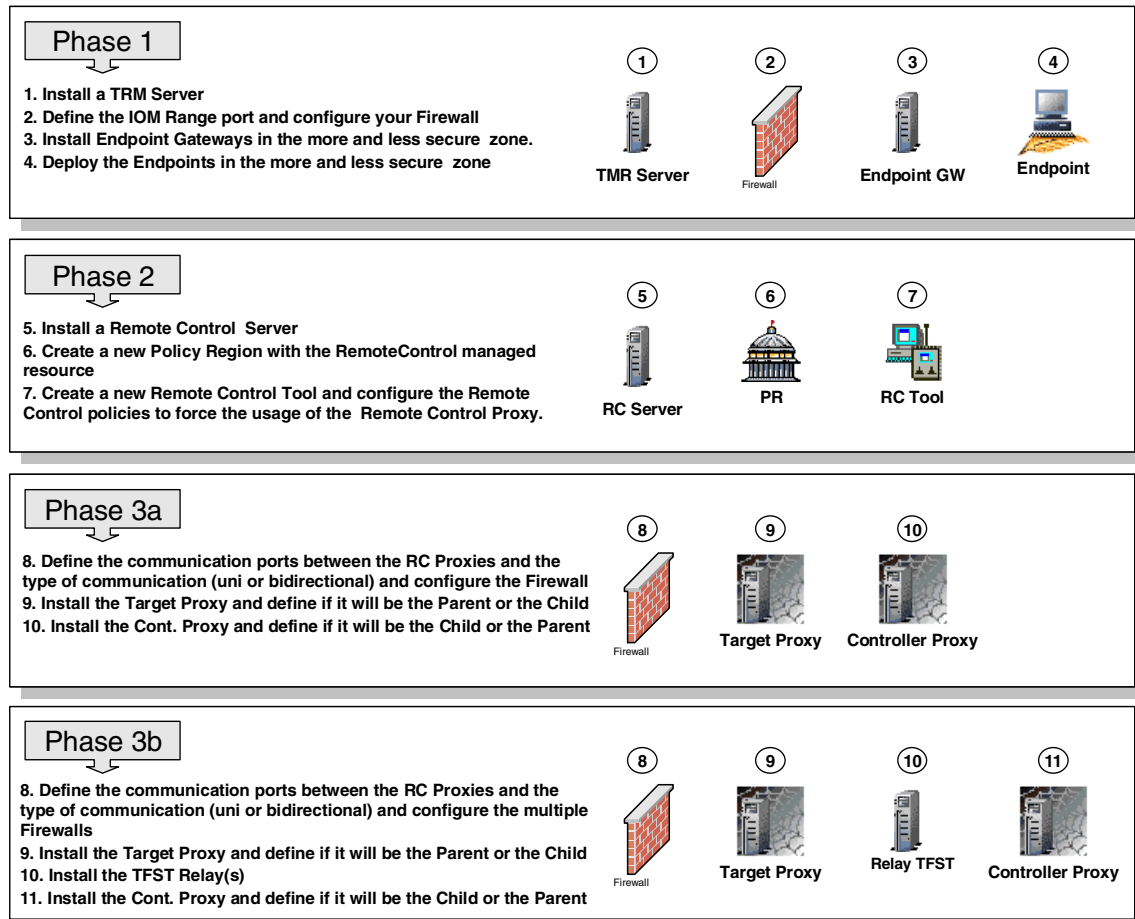

Figure 2-1 Planning overview for RC Proxy in a Standalone environment

Figure 2-2 shows the entire installation process, which includes the supporting application and the required firewall configurations phases for a IBM Tivoli Remote Control Proxy RCProxy-TFST environment.

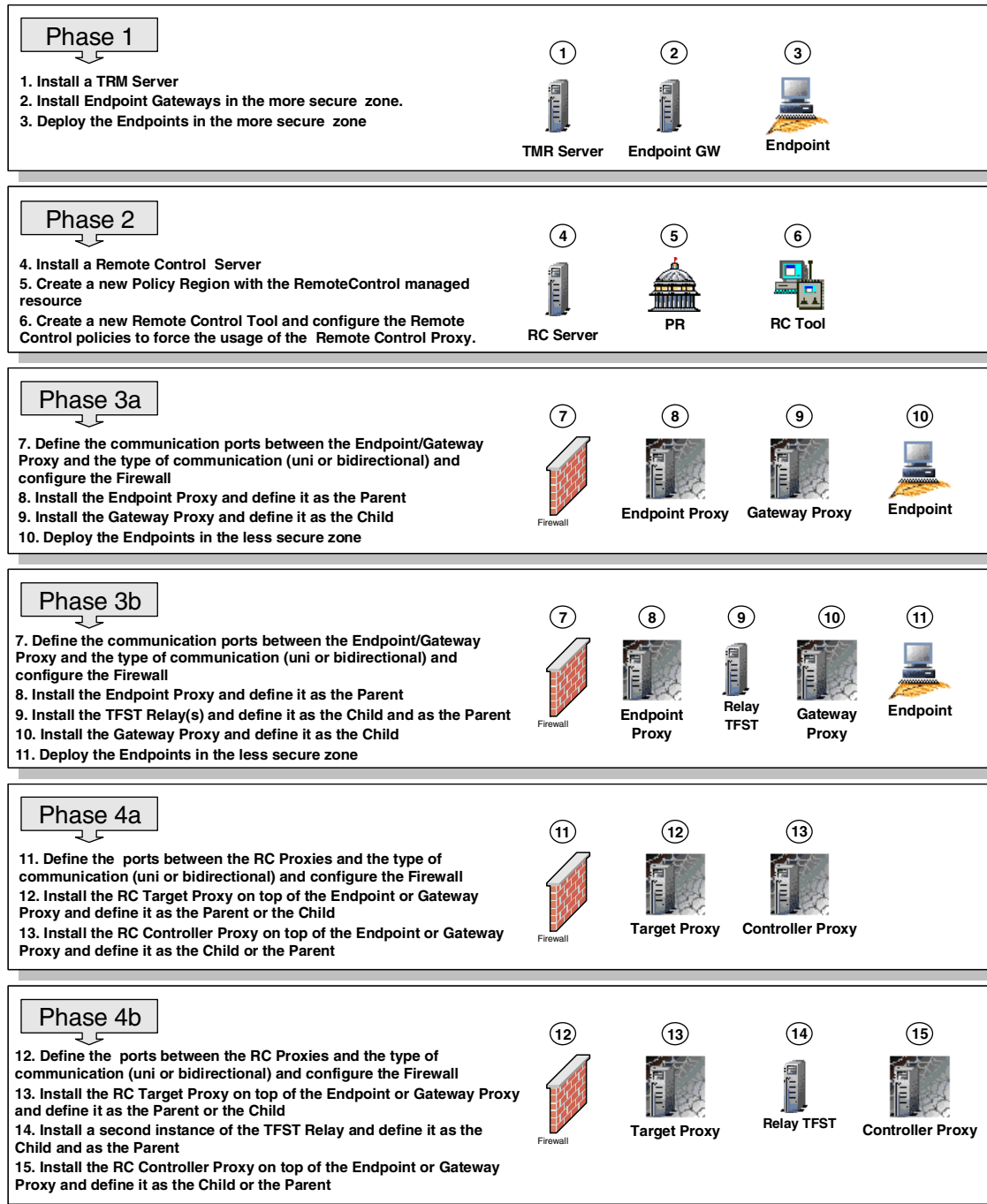

Figure 2-2 Planning overview for Remote Control Proxy in a TFST environment

## Supporting applications requirements

Before installing any IBM Tivoli Remote Control Proxy, you must have the following software components installed, up and running:

- ▶ IBM Tivoli Management Framework 3.7.1 or higher.
- ▶ IBM Tivoli Remote Control 3.8 or higher.
- ▶ Tivoli Firewall Security Toolbox 1.3 or higher for an RC Proxy Non-Standalone architecture.

In addition, you must install:

- ▶ IBM Tivoli Management Framework Agent of the IBM Tivoli Management Framework 3.7.1 or higher (Icf version 91 or higher) on the workstations that should work as Controllers and Targets.
- ▶ IBM Tivoli Management Framework desktop on the workstations where you want to use the Tivoli Remote Control graphical user interface.

You need to have one of the following Web browsers on the workstations where you want to use the IBM Tivoli Remote Control Web interface:

- ▶ Netscape 4.6 or later
- ▶ Internet Explorer 5.0 or 5.5+SP1®

## Hardware requirements

Table 2-7 lists the minimum hardware requirements. These requirements are only for the IBM Tivoli Remote Control Proxies. If you plan to use a Non-Standalone solution, you should also take in consideration the hardware requirements for the Tivoli Firewall Security Toolbox.

Table 2-7 Hardware requirements for IBM Tivoli Remote Control Proxy

HW	Intel platforms	AIX® platforms	SUN platforms
Processor	Any Pentium systems	Any pSeries™ systems	Any SPARC systems
RAM	64 MB minimum 128 MB recommended	64 MB RAM minimum 128 MB recommended	64 MB RAM minimum 128 MB recommended
Hard disk	28.3 MB for Windows 35.7 MB for Linux	32.1MB	57.8 MB

Always refer to the IBM Tivoli Remote Control Release Notes, SC23-4844, for up-to-date hardware requirements for IBM Tivoli Remote Control Proxies.



## Software requirements

Before starting the installation of the IBM Tivoli Remote Control Proxy, you should have installed the minimum product levels listed in the Table 2-8. These requirements are only for the IBM Tivoli Remote Control Proxies. If you plan to use a Non-Standalone solution, you should also take in consideration the software requirements for the Tivoli Firewall Security Toolbox. Please always refer to the IBM Tivoli Remote Control Release Notes, SC23-4844 for up-to-date software requirements for IBM Tivoli Remote Control Proxies.

Table 2-8 Software requirements for IBM Tivoli Remote Control Proxy

Operating system	Required version
AIX ®	4.3.3 (4330-02 ML) / 5.1
Solaris Operating Environment	7 / 8 (All JRE 1.3 and Java 2 SDK, Standard Edition, v1.3.1 patches can be located at: <a href="http://java.sun.com/j2se/1.3/install-solaris-patches.html">http://java.sun.com/j2se/1.3/install-solaris-patches.html</a> )
Red Hat Linux Server	7.1 / 7.2
SuSE Linux	7.3
TurboLinux	6.5
Windows 2000	Server / Advanced Server

For the UNIX platform, you need to have 48 MB of available space in the /tmp file system.

## Information you will need for the installation

The IBM Tivoli Remote Control Proxy Standalone installation process will require you to fill in the following information, and will offer advice about the values you can use during the installation process:

- ▶ Common parts for all installation types, Standalone and Non-Standalone:  
You will be asked for the following information:
  - Licence acceptance:  
You must accept the licence agreement.
  - The destination directory for the installation:  
By default, the Directory is as follows:  
On Windows: C:\Program Files\Tivoli Systems\Remote Control Proxy  
On UNIX: /opt/Tivoli Systems/Remote Control Proxy

This file system will contain the binaries and configuration files for the application. It is recommended to install such applications in another Logical Partition than the Operating System. Furthermore, a directory structure with no spaces in the name could be easier to manage — just in case the directory name might be used in a script, for example.

– Type of installation:

If you choose to add a label to this Proxy, then this Proxy will become a Child. Otherwise, the Proxy will become a Parent.

**Note:** This step only concerns an RC Proxy Standalone installation process. In a Non-Standalone process, the setup application discovers if either an Endpoint or Gateway Proxy is installed on the local machine. Then, it defines the RC Proxy as the Parent if it discovers an Endpoint Proxy, and the RC Proxy as the Child if it discovers a Gateway Proxy.

► If the installation refers to a Standalone mode with a Parent proxy, or an installation on top of an existing Endpoint Proxy, the process will ask for the following information:

– A listening port for the Parent from which it listens for Child connections:

This information will be saved in the `children_local_port` parameter in the `[communication-layer]` section of the `rcproxy.cfg` configuration file.

– An IP Address of the Child (or DNS name) and on which port this Child will be listening for the Parent connections. Repeat this step for all Children you need to define for this Parent.

This information will be saved in the `children_remote_list` parameter in the `[communication-layer]` section of the `rcproxy.cfg` configuration file.

– A type of connection:

This choice must be in accordance with the security rules defined by your Security Officer regarding how communication must be exchanged between different network zones. Refer to 1.1.5, “Proxy connection types” on page 11 for more information about the different types of communications.

This information will be saved in the `children_cm_type` parameter in the `[communication-layer]` section of the `rcproxy.cfg` configuration file. If the connection type selected is unidirectional, the Parent role is saved in the `connection-mode` parameter in the `[children-cm-info]` section of the `rcproxy.cfg` configuration file.

- A list of Tivoli Endpoints that will act as Targets with their dedicated Remote Control Proxy:

This list will be used to find the route to contact the RC Target. This information will be saved in the `rcproxy.route` definition file.

**Note:** This step only concerns an RC Proxy Standalone installation process. In a Non-Standalone process, this information is managed by the Endpoint Proxy and the RC Proxy does not need to maintain a local route file.

- A Proxy role:

You have to define if the Parent proxy will act as an RC Target or an RC Controller Proxy.

For the RC Target Proxy, the process will ask you for the following information:

- A port from which it listens for RC Controller connections:

This port must be the same as registered in the `rc_def_proxy` Policy. This information will be saved in the `proxy-port` parameter in the `[rcproxy]` section of the `rcproxy.cfg` configuration file.

- A listening port for commands of a command line:

This information will be saved in the `command-line-port` parameter in the `[rcproxy]` section of the `rcproxy.cfg` configuration file.

- ▶ If the installation concerns a Standalone Child installation or an installation on top of a Gateway Proxy, the process will ask you for the following information:

- A Proxy label:

This information is used to identify the Child Proxy to its Parent Proxy. It will be saved in the `proxy-label` parameter in the `[rcproxy]` section of the `rcproxy.cfg` configuration file.

**Note:** This step only concerns an RC Proxy Standalone installation process. In a Non-Standalone process, the Proxy label will be the same name defined for the Gateway Proxy.

- A port to be used to listen to Parent connections:

This information will be saved in the `parent_local_port` parameter in the `[communication-layer]` section of the `rcproxy.cfg` configuration file.

- The IP Address (or DNS name) of the Parent:  
This information will be saved in the `parent-remote-host` parameter in the `[communication-layer]` section of the `rcproxy.cfg` configuration file.
- The listening port of the Parent:  
This information will be saved in the `parent-remote-port` parameter in the `[communication-layer]` section of the `rcproxy.cfg` configuration file.
- The type of connection:  
This choice must be in accordance with the security rules defined by your Security Officer regarding how communication must be exchanged between different network zones. Refer to 1.1.5, “Proxy connection types” on page 11 for more information about the different type of communications.  
  
This information will be saved in the `parent_cm_type` parameter in the `[communication-layer]` section of the `rcproxy.cfg` configuration file. If the connection type selected is unidirectional, the Child role is saved in the `connection-mode` parameter in the `[parent-cm-info]` section of the `rcproxy.cfg` configuration file.
- A Proxy role:  
You have to define if this Child will be an RC Target Proxy or an RC Controller Proxy.  
  
For the RC Target Proxy, the process will ask you for the following information:
  - A port from which it listens for RC Controller connections.  
This port must be the same as registered in the `rc_def_proxy` Policy. This information will be saved in the `proxy-port` parameter in the `[rcproxy]` section of the `rcproxy.cfg` configuration file.
- A listening port for commands of a command line:  
This information will be saved in the `command-line-port` parameter in the `[rcproxy]` section of the `rcproxy.cfg` configuration file.

## 2.3 Implementation planning case study scenario

Next, we provide a case study scenario which will help you to understand where to place the different components of the IBM Tivoli Remote Control Proxy, and in which situation an RC Proxy Standalone or an RC Proxy Non-Standalone solution should be selected.

This section provides some examples of the implementation planning that can be implemented for that particular scenario. It is meant to help systems administrators to understand the different solutions for using IBM Tivoli Remote Control across firewalls. However, it does not provide all details needed for a complete implementation. Complete details and more realistic implementations will be provided in Chapter 3, “Implementation scenario: Standalone Proxies” on page 93 and Chapter 4, “Implementation scenario: Tivoli Firewall Security Toolbox” on page 115. Additional information can also be found in the *IBM Tivoli Remote Control User’s Guide*, SC23-4842 and in 1.2, “IBM Tivoli Remote Control sessions overview” on page 12.

### **Implementation planning case study overview**

This case scenario provides a fictitious example of an Enterprise, named CSI Corporation, who decided to outsource its first and second level support, for both workstations and servers, to IBM Switzerland.

In fact, some Endpoint parts of the Tivoli Management Region of the CSI Corporation are installed in the IBM office, which is linked to the customer site with a 128 MB WAN access. These Endpoints will act as the Controllers. However, as these Endpoints in the IBM site are located in the External network zone, and their respective Tivoli Endpoint Gateways are located in the Internal zone, a connection from the Endpoints to their Tivoli Endpoint Gateway must cross a DMZ to be completed. For this reason, the following components have to be installed:

- ▶ A Gateway Proxy in the External zone
- ▶ A second instance of the Relay in the DMZ
- ▶ An Endpoint Proxy connected to a dedicated Tivoli Gateway for IBM Endpoints, in the Internal zone.

All workstations of the customer are placed in the Internal network zone. The Security Officer of the CSI Corporation has defined a secure network zone inside the enterprise to protect most of the enterprise servers. In this case, all IBM Switzerland Administrators thus need to have Remote Control access to both the Internal and the Servers network zones.

Furthermore, in order to maximize security, the Security Officer has decided on the following communication types:

- ▶ Bidirectional between the Endpoint Proxy and the Relay — that is, between the Internal network zone and the DMZ
- ▶ Restricted to unidirectional between the Relay and the Gateway Proxy — that is, between the DMZ and the External network zone

We should also point out that a Tivoli Endpoint Gateway was already deployed before the Tivoli Firewall Security Toolbox technology had been announced, in order to manage the Endpoints in the Servers zone.

Figure 2-3 depicts the current CSI Corporation Tivoli environment prior to the IBM Tivoli Remote Control Proxy solution deployment. The External zone represents the site where the first and second level support location. The DMZ, Internal, and Servers zones are all located at CSI's main site.

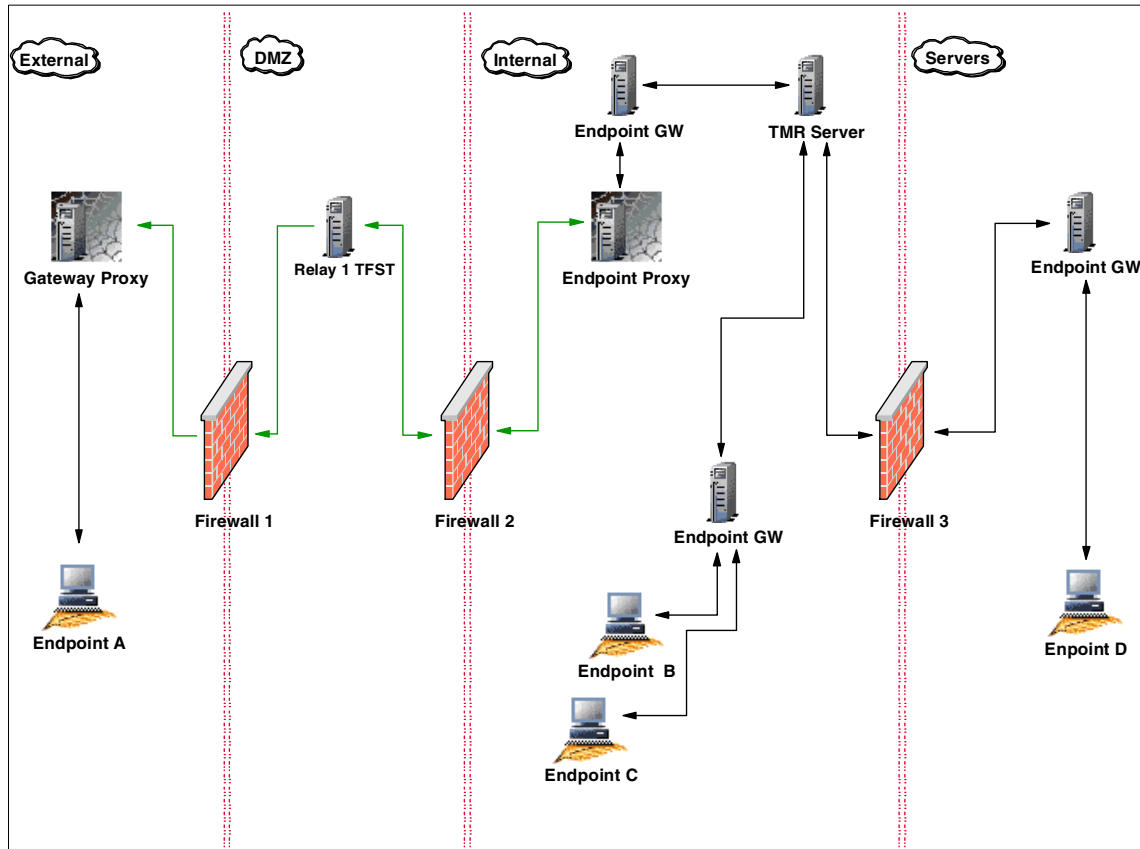

Figure 2-3 Case study scenario without RC Proxy architecture

Based on Figure 2-3, there can be several ways to implement A Remote Control solution for CSI. The following sections present two possible implementation planning as follows:

- ▶ Using a combination of Standalone and Non-Standalone solutions
- ▶ Using Non-Standalone mode solution only

## Implementation Planning Case Study: Solution A

Based on the information gathered in the previous section, we decide to install an RC Controller in the external zone, specifically on Endpoint A. Also, all Targets are located in both the Internal and Servers zone, represented by Endpoints B, C, and D in Figure 2-3. Thus, Endpoint A must be able to contact Endpoint B, Endpoint C, and Endpoint D. This means that the connection from the Controller (Endpoint A) to the Targets in the Internal Zone (Endpoints C and D) must cross two firewalls, and to the Targets in the Servers zone (Endpoint D) three firewalls.

Furthermore, Endpoint D is managed by a Tivoli Endpoint Gateway placed in the same secure network zone. In such a situation, only an IBM Tivoli Remote Control Proxy Standalone solution could be used to access those Targets. In addition, because Endpoint A is managed by an Endpoint/Gateway Proxy A architecture, it is possible to deploy an IBM Tivoli Remote Control Proxy Non-Standalone solution on top of the Tivoli Firewall Security Toolbox components to manage targets in the Internal zone. Thus, in this architecture, a mixed IBM Tivoli Remote Control Proxy solution needs to be deployed.

At this point, we have identified the firewall scenarios and restrictions and we could start designing the architecture of the Remote Control solution.

Figure 2-4 depicts the proposed Tivoli environment with an IBM Tivoli Remote Control Proxy solution for CSI Corporation, for Solution A.

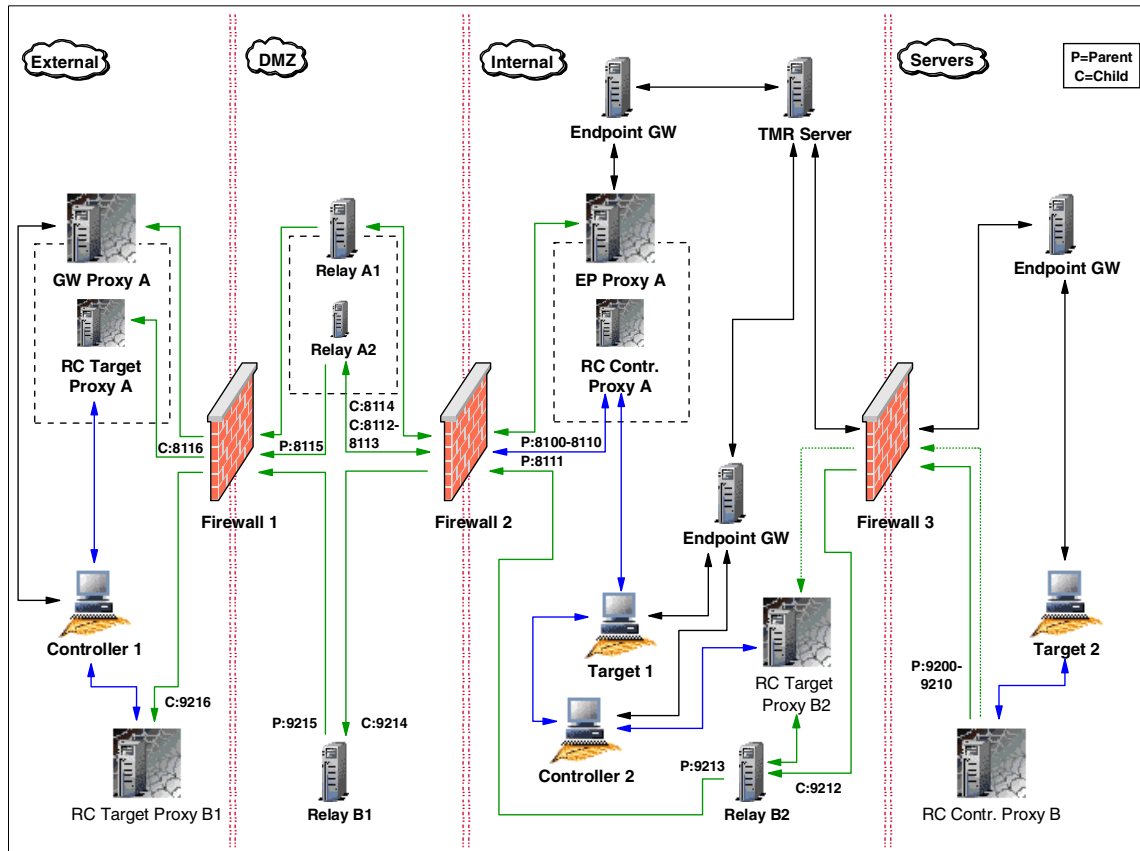

Figure 2-4 Case study scenario with RC Proxy architecture - Solution A

In terms of Remote Control functionality, there are three main requests that need to be addressed:

- ▶ Controllers in the External zone connecting Targets in the Internal zone:

For Controller 1 to contact Target 1, we are able to use the Endpoint/Gateway Proxy A architecture. As Controller 1 is in the External network zone, we need to install the RC Target Proxy A on top of the Gateway Proxy A. This means that the RC Target Proxy A automatically becomes a Child. In addition, we have to install an RC Controller Proxy A on top of the Endpoint Proxy A, and, of course, this component becomes the Parent, as it is installed on top of a TFST Parent component. As a DMZ zone separates the Controller 1 from the Target 1, a new instance of the Relay, Relay A2, component must be installed on top of the existing Relay A1.



As per existing security guidelines, the Security Officer of the CSI Corporation imposes for this communication the same constraints defined for the Endpoint/Gateway Proxy A architecture. In other words, communication between the RC Controller Proxy A and the Relay A2 is set as bidirectional, and between this Relay A2 and the RC Target Proxy A is set as unidirectional. In this scenario, Controller 1 is able to contact Target 1 using the A path.

- ▶ Controllers in the External zone connecting Targets in the Servers zone:

Controller 1 needs also to be able to contact Target 2 in the Server zone. As Target 2 is managed by a Tivoli Endpoint Gateway, placed in the same zone, we need to deploy an RC Proxy Standalone solution. This means that RC Controller Proxy B must be placed in the same zone as Target 2 and RC Target Proxy B1 in the same zone as Controller 1.

However, in this case, two network zones separate the Controller 1 from the Target 2. Thus, a TFST Relay must be installed in each zone in between. They are Relay B1 and Relay B2 and are chained to create a direct link between the two RC Proxies B. It is not possible to use Relay A2 already installed for the first channel because the Parent and Child hierarchy is totally different. For this second channel, we decided that the RC Controller Proxy B is a Parent and, consequently, the RC Target Proxy B1 is the Child. This choice is very important and it will be clear as soon as we explain how Controller 2 contacts Target 2. The two Relays B in between will assume the both roles, Parent and Child, at the same time.

- ▶ Controllers in the Internal zone connecting Targets in the Servers zone:

AS CSI Corporation is keeping the Level 3 support responsibility, CSI administrators need to have remote control access to Targets in both Internal and Servers zone as well. As Controller 2 is in the same secure zone as Target 1, the standard non-secure IBM Tivoli Remote Control process is used. However, as Controller 2 is not able to contact Target 2 using Relay B2, an RC Target Proxy needs to be installed in the Internal network zone. Target Proxy B2 could either be installed on the same machine as the Relay B2 or as a Standalone machine. Furthermore, there are two possibilities to connect this RC Target Proxy B2 to the RC Controller Proxy B:

- Open a new connection in the firewall to let RC Target Proxy B2 communicate directly with RC Controller Proxy B.
- Connect RC Target Proxy B2 to the Relay B2 even if they are in the same network zone.

The main advantage of the second option is that there is no need to open additional ports in the firewall as the communication occurs between the Relay B2 and the RC Controller Proxy B. However, connecting the RC Target B1 to the Relay B2 might decrease the performance of the session, because Relay B2 also handles communication originated from Controller 1.

In this scenario, we decided on the more secure solution and decide to connect the RC Target Proxy B2 to the Relay B2. In addition to that, RC Controller Proxy B is the Parent and, as a Parent could have more than one Child, this allows us to connect the Relay B2 and the RC Target Proxy B1 to the RC Controller Proxy B or to connect the Relay B1 and the RC Target Proxy B2 to the Relay B2.

As per existing security guidelines, the Security Officer of the CSI Corporation imposes only a requirement that the components placed in the more secure site of each firewall are able to initiate the communication to the component on the less secure side. This means only a unidirectional communication from the RC Controller Proxy B to the RC Target Proxy B1 and to the RC Target Proxy B2 is allowed. In this scenario, Controller 1 and Controller 2 are able to contact Target 2 using the B path.

The following tables summarize all needed network communications ports that may help in configuring both the Remote Control Proxies and TFST components, as well as the firewalls for Solution A.

Note that the ports provided in the following tables are examples used in this particular case study scenario only.

*Table 2-9 RC Proxy network ports for firewall 1 - Solution A*

Source		Destination		Protocol	Description
Type (Service)	Ports	Type (Service)	Ports		
Relay A2 (Relay)	8115	Target Proxy A (rcproxy)	8116	TCP	<b>Firewall rule needed.</b> Initiated at service startup time. Polling interval is 2 seconds.
Relay B1 (Relay)	9215	Target Proxy B1 (rcproxy)	9216	TCP	<b>Firewall rule needed.</b> Started at service time. Polling interval is 2 seconds.

Table 2-10 RC Proxy network ports for firewall 2 - Solution A

Source		Destination		Protocol	Description
Type (Service)	Ports	Type (Service)	Ports		
Controller Proxy A (rcproxy)	8100-8110	Relay A2 (Relay)	8114	TCP	<b>Firewall rule needed.</b> Initiated at service startup time
Relay A2 (Relay)	8112-8113	Controller Proxy A (rcproxy)	8111	TCP	<b>Firewall rule needed.</b> Initiated at service startup time.
Relay B2 (Relay)	9213	Relay B1 (Relay)	9214	TCP	<b>Firewall rule needed.</b> Initiated at service startup time. Polling interval is 2 seconds.

Table 2-11 RC Proxy network ports for firewall 3 - Solution A

Source		Destination		Protocol	Description
Type (Service)	Ports	Type (Service)	Ports		
Controller Proxy B (rcproxy)	9200-9210	Relay B2 (Relay)	9212	TCP	<b>Firewall rule needed.</b> Initiated at service startup time. Polling interval is 2 seconds.

The solution presented in this section allows the Controllers in the External and Internal network zones to access Targets in the Internal and Servers zone. However, this solution implies the deployment of the both Standalone and Non-Standalone architectures.

In the next section, we present an alternative solution for CSI that can be simpler and has requires less components and port to be opened in the firewalls. However, this solution requests some changes at the Tivoli Framework physical design, which is not always feasible in production environments.

## Implementation Planning Case Study: Solution B

In this scenario, the requirements imposed by CSI Corporation are the same as presented for Solution A. The goal for in this section is to provide an alternate solution design for CSI — in this case, a change on the existing physical design by eliminating the current Tivoli Endpoint Gateway installed in the Servers network zone. This will allow us to close the IOM Range and other Tivoli ports in the firewalls and decide upon a unidirectional communication from the Servers zone to the Internal zone. In this case, with a new Endpoint/gateway Proxy connection, only one pipe needs to be opened in Firewall 3. In terms of a firewall security solution, this architecture provides a great enhancement. In addition to that, there is only the need to use the RC Non-Standalone solutions.

Figure 2-5 depicts the proposed CSI Corporation Tivoli environment with an IBM Tivoli Remote Control Proxy solution, for Solution B.

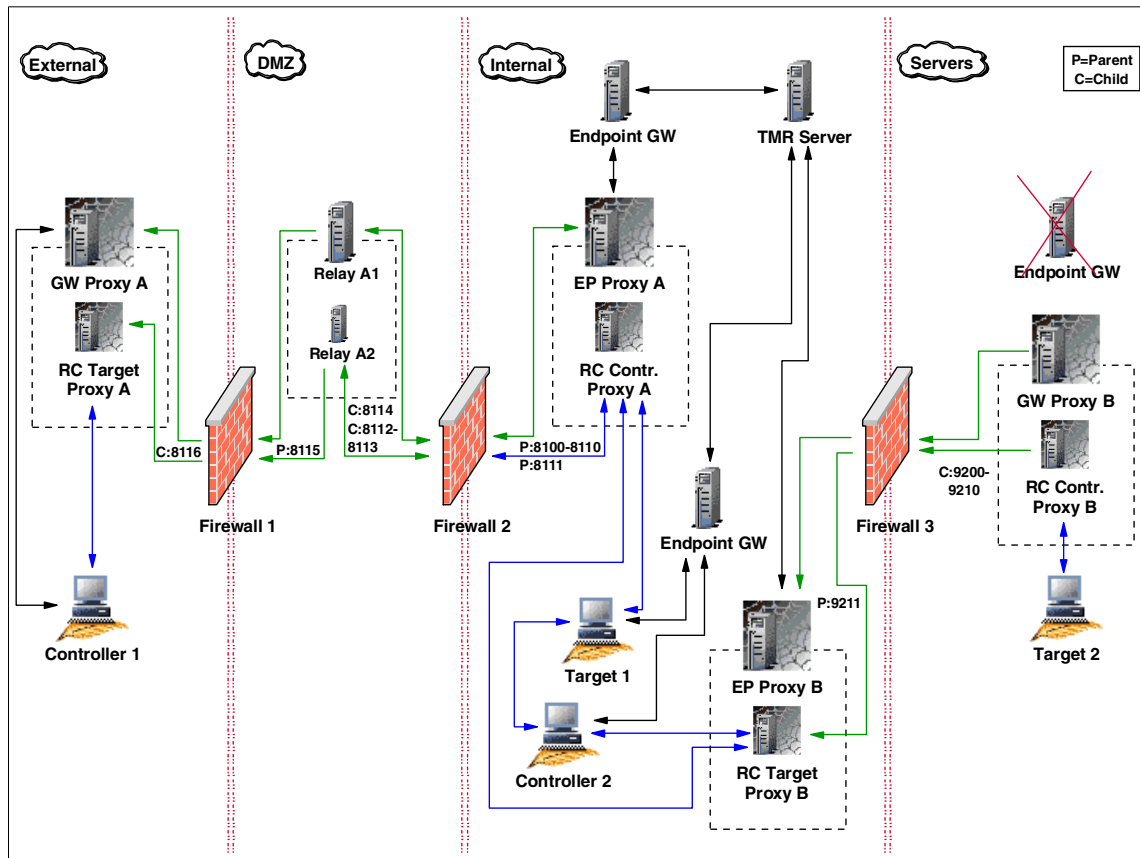

Figure 2-5 Case study scenario with RC Proxy architecture - Solution B

Similarly to Solution A, there are three main requests that need to be addressed:

- ▶ Controllers in the External zone connecting Targets in the Internal zone:

The change in the design has no affect on this request, and Controller 1 is able to connect to Target 1 using the A path, as described in “Implementation Planning Case Study: Solution A” on page 83.

- ▶ Controllers in the External zone connecting Targets in the Servers zone:

The second requirement is that Controller 1 needs to contact Target 2 in the Server zone. As shown in Figure 2-5, because the Endpoint Gateway was removed from the Server zone, a new Endpoint/Gateway Proxy B architecture needs to be deployed to manage Targets in the Server zone.

For Remote Control operations, a new RC Target Proxy B needs to be installed on top of the Endpoint Proxy B and it becomes automatically a Parent, as the Endpoint Proxy is a Parent. On the other side of Firewall 3, a new RC Controller Proxy B needs to be installed on top of the Gateway Proxy B, and, of course, this component becomes the Child. Using this architecture, the request from Controller 2 is forwarded from the A path to the B path using the Endpoint Proxy *routing technology*.

**Important:** Requests initiated by a Controller can be forwarded from one RC Target Proxy/RC Controller Proxy architecture to another RC Target Proxy/RC Controller Proxy architecture. However, these two architectures *must* be RC Proxy Non-Standalone solutions, because the request is transmitted from one part to the other using the routing technology of the Endpoint Proxy components.

For more information about the Endpoint Proxy routing technology, refer to the *Firewall Security Toolbox User 's Guide*, GC23-4826 and to the *Tivoli Enterprise Management Across Firewalls*, SG24-5510.

- ▶ Controllers in the Internal zone connecting Targets in the Servers zone:

The third requirement is still raised by the CSI Level 3 support group. These administrators need to have remote control access to Targets in both Internal and Servers zone. Targets in the Internal zone will be managed by Controller 2 using the non-secure 1 IBM Tivoli Remote Control process. However, the Controller 2 could benefit from the RC Proxy architecture to get the Target 2 sited in the Servers zone. It just needs to connect to the RC Target Proxy B, which will transfer the request to the RC Controller Proxy B. So, the Controller 2 is able to contact the Target 2 using the B path.

Table 2-12, Table 2-13, and Table 2-14 summarize all of the necessary network communications ports that may help in configuring the RC Proxies, TFST components, as well as the firewalls of CSI Corporation.

Note that the ports provided in these tables are examples specific to this case study scenario.

Table 2-12 RC Proxy network ports for firewall 1 - Solution B

Source		Destination		Protocol	Description
Type (Service)	Ports	Type (Service)	Ports		
Relay A2 (Relay)	8115	Target Proxy A (rcproxy)	8116	TCP	<b>Firewall rule needed.</b> Initiated at service startup time. Polling interval is 2 seconds.

Table 2-13 RC Proxy network ports for firewall 2 - Solution B

Source		Destination		Protocol	Description
Type (Service)	Ports	Type (Service)	Ports		
Controller Proxy A (rcproxy)	8100-8110	Relay A2 (Relay)	8114	TCP	<b>Firewall rule needed.</b> Initiated at service startup time.
Relay A2 (Relay)	8112-8113	Controller Proxy A (rcproxy)	8111		<b>Firewall rule needed.</b> Initiated at service startup time.

Table 2-14 RC Proxy network ports for firewall 3 - Solution B

Source		Destination		Protocol	Description
Type (Service)	Ports	Type (Service)	Ports		
Controller Proxy B (rcproxy)	9200-9210	Target Proxy B2 (rcproxy)	9211	TCP	<b>Firewall rule needed.</b> Started at service time. Polling interval is 2 seconds.



# Part 2

# Implementation scenarios







## Implementation scenario: Standalone Proxies

In this chapter we explain the techniques used to implement IBM Tivoli Remote Control 3.8 in a firewall environment. The scenario we describe will help you understand the requirements for establishing Remote Control sessions when a firewall is involved, using a more secure mechanism, the Remote Control Proxy technology in Standalone mode. These topics are covered:

- ▶ Our testing scenario: Using Remote Control Proxies in Standalone mode
- ▶ Remote Control data flow, TCP/IP ports used, and firewall configuration
- ▶ Remote Control Proxies installation and configuration

We make the following assumptions:

- ▶ You have a working knowledge of the TME® architecture and of the IBM Tivoli Management Framework 4.1
- ▶ You have a basic understanding of Tivoli Firewall Security Toolbox 1.3 (TFST). Appendix A, “Tivoli Firewall Security Toolbox overview” on page 175 provides an overview of the main TFST components.
- ▶ You have a basic understanding of large enterprise network architecture, firewall and proxies.

## 3.1 Scenario overview

In this section, we provide an overview of our Remote Control in Standalone mode testing scenario. A typical Remote Control in Standalone mode is defined when the Tivoli Management Gateway (Gateway) and its Endpoints are separated from the Remote Control Controller by a firewall.

The goal of this scenario is to provide detailed information to the System Administrators of the requirements and considerations that will help them work with session management across a firewall.

Since firewalls restrict the communication channel, we will show how Remote Control can work through the firewall, respecting its restrictions, and how the Remote Control Proxies are used for this purpose.

We have included tables of information on ports that need to be configured in the firewall in order to establish Remote Control sessions, as well as pictures related to the scenario we are describing, outlining the flow of data, and a detailed description of the steps required to make such an environment work properly.

Wherever possible, we point out the differences between UNIX and non-UNIX platforms, trying to cover as many situations as possible.

In this testing scenario, we assume the IBM Tivoli Management Framework has been properly installed and that the communication between Endpoints and Gateways, TMR server, and managed nodes work as well. You can refer to the *Tivoli Enterprise Management Across Firewalls*, SG24-5510 for information on this area. This is the basic requirement before configuring and installing IBM Tivoli Remote Control across firewalls. We also assume that the IBM Tivoli Remote Control 3.8 server component is already installed on the TMR server as well as on all Tivoli Gateways hosting the Endpoints, Controllers, and Targets. For additional information, refer to the *IBM Tivoli Remote Control User's Guide*, SC23-4842.

## 3.2 Environment description

In our testing scenario, the goal was to reproduce the most common environment using all the required components in order to provide valuable inputs and illustrate our conclusions. We used different machine types and operating systems. Even though the goal here is not to test firewall products, we used different firewall products with this configuration, keeping in mind the services, protocol, and ports used by the Remote Control Proxies.

As described in Chapter 2, “Implementation planning” on page 57, the following are important items to be considered when planning IBM Tivoli Remote Control 3.8 across firewalls:

- ▶ Firewall topology and its restrictions
- ▶ Placement of Remote Control Controller (RC Controller), Targets, Remote Control Controller Proxy (RC Controller Proxy), and remote Control Target Proxy (RC Target Proxy)
- ▶ Decision on Parent-Child relationship of RC Controller and RC Target Proxies
- ▶ Communication flow: unidirectional or bidirectional communication
- ▶ Hostname and the port used by the RC Controller and RC Target Proxies

The Remote Control Proxies are new components introduced by IBM Tivoli Remote Control 3.8 and are used to simplify the communication between Controller and Targets across firewalls. Remote Control Proxies can be installed on any machine on your environment, and don't need necessarily to be installed on a machine part of the TME. We recommend that you refer to Chapter 2, “Implementation planning” on page 57 to check the supported platforms for this application.

An RC Target Proxy is the component that is connected to the Controllers acting as a Target. The RC Controller Proxy is the component that is connected to the Targets acting as a Controller. These two proxies then communicate to each other through the firewall, using the HTTP protocol.

Prior to installing any Remote Control Proxy component, you need to decide which one will be the Parent Proxy and which one will be the Child Proxy. Usually to get a better and more secure configuration, we recommend that you configure the RC Target Proxy as the Parent and the RC Controller Proxy as the Child. This is because the RC Target Proxy is usually connected to a few Controllers, while the RC Controller Proxy is usually connected to several Targets. Refer to Chapter 1, “Remote Control sessions overview” on page 3 for details.

### **3.2.1 Technical infrastructure**

This section provides a description of our lab environment for the Standalone environment, showing the machine type, operating system, and Tivoli resource we installed on each machine.

For convenience, we installed some components on the same machine, but you can have them on different boxes.

Figure 3-1 illustrates the general testing scenario used in our lab.

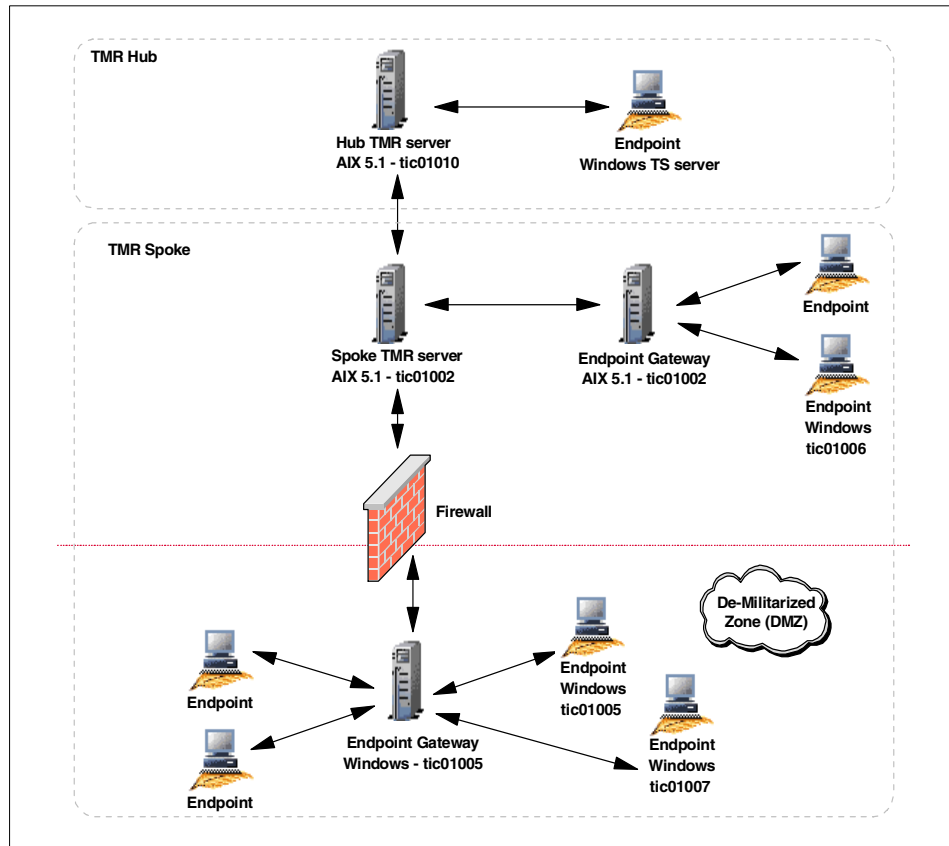

Figure 3-1 General testing scenario

This scenario includes interconnected TMR using the Hub and Spoke architecture, two different Gateways and a set of Endpoints. One of the Gateways is placed in the DMZ (less secure side) to which the Target Endpoints belong, while the other one is placed on the more secure side, to which the Controller Endpoints belong.

Our Administrators have been defined in the TMR Spoke environment, where we have the Controllers. The intention here is to establish Remote Control sessions from TMR Spoke environment (more secure side) to DMZ (less secure side). In our scenario, we defined the Endpoint tic01006 to be a Controller and the Endpoints tic01005 and tic01007 to be the Targets.

For our testing, we used the following products and release levels:

- ▶ Operating systems:
  - IBM AIX 5.1
  - Microsoft Windows 2000 Advanced Server
  - Microsoft Windows 2000 Professional
- ▶ Tivoli Software:
  - IBM Tivoli Management Framework 4.1
  - IBM Tivoli Remote Control 3.8

We interconnected the Hub and Spoke TMR, using a two-way connection, and exchanged the following Tivoli resources:

- ▶ Administrator (two-way)
- ▶ AdministratorCollection (two-way)
- ▶ ManagedNode (two-way)
- ▶ Endpoint (two-way)
- ▶ PolicyRegion (two-way)
- ▶ ProfileManager (two-way)
- ▶ EndpointManager (one-way; only one time from the Spoke to the HUB TMR)

**Note:** We have not exchanged the RemoteControl resource because, in our scenario, there are no Controllers connected to the HUB TMR.

Information related to the interconnected TMRs, managed nodes, their status and IP addresses can be obtained by using **odadmin** command, as shown in both Example 3-1 for the TMR Hub and Example 3-2 for the TMR Spoke.

*Example 3-1 Hub TMR region*

---

```
# odadmin odlist
Region      Disp  Flags  Port      IPaddr    Hostname(s)
1380596993  1     ct-    94        9.3.4.71  tic01010
1519322503  1     ct-    94        9.3.4.169 tic01002
```

---

*Example 3-2 Spoke TMR region*

---

```
# odadmin odlist
Region      Disp  Flags  Port      IPaddr    Hostname(s)
1519322503  1     ct-    94        9.3.4.169 tic01002
             5     ct-    94        10.10.10.5 tic01005
1380596993  1     ct-    94        9.3.4.71  tic01010
```

---

We defined both TMRs and the managed node as Tivoli Gateway resources, as shown in the Example 3-3 and Example 3-4 that list the **wgateway** command output.

*Example 3-3 Hub TMR Endpoint Gateway*

---

Object	Name	Status
1380596993.1.578	tic01010-gw	u

---

*Example 3-4 Spoke TMR Endpoint Gateway*

---

Object	Name	Status
1519322503.1.578	tic01002-gw	u
1519322503.5.21	tic01005-gw	u

---

We defined the machine tic01005 as the Gateway in the DMZ (less secure side) hosting the Targets Endpoints and the machine tic01002 as the Gateway on the more secure side hosting the Controllers Endpoints.

We installed the Remote Control Server on TMR Spoke/Gateway (tic01002), and on the Gateway standing on the less secure side of the firewall (tic01005).

Figure 3-2 shows how we implemented the Remote Control Proxies in the general testing scenario.

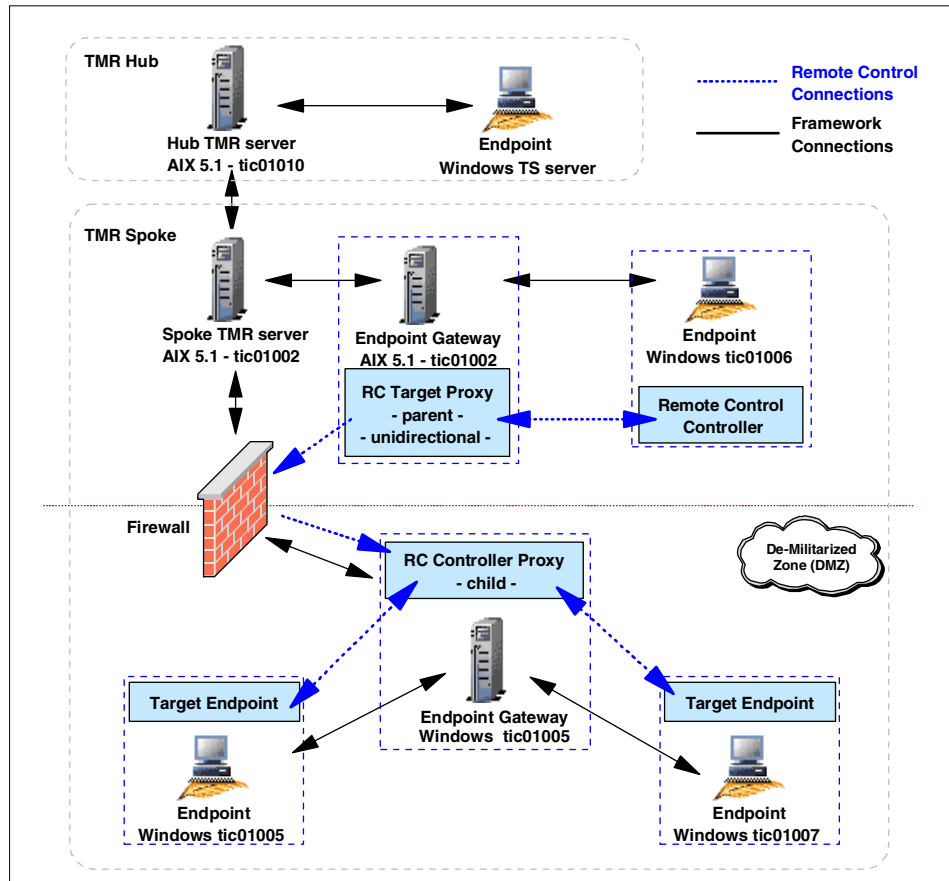

Figure 3-2 RC Proxy Implementation

In this environment, we defined the machine tic01002 as RC Target Proxy and the machine tic01005 as RC Controller Proxy. In our case, both of these are also the Tivoli resources.

The RC Target Proxy has been defined as Parent Proxy, and the RC Controller Proxy has been defined as Child Proxy. We use a unidirectional connection, and we define the RC Target Proxy as the initiator.

### 3.2.2 Data flow description

In this section we describe the data flow in our network topology based on our testing scenario. We also highlight the ports used for the communication between each Remote Control component, preparing the base for 3.3.3, "Firewall configuration table" on page 108.

The schema reported in Figure 3-3 shows an overview of the data flow in our Remote Control StandAlone environment.

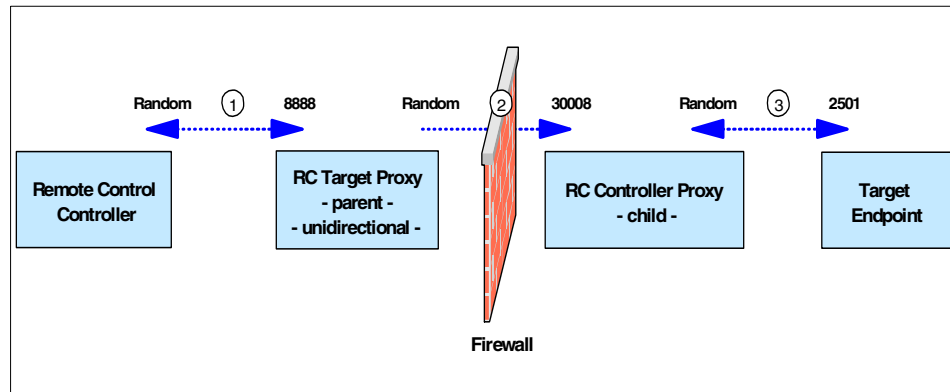

Figure 3-3 Remote Control Data Flow Overview

To briefly describe how the data flow structure is, we numbered each connection reported in Example 3-3, specifying the ports required to establish each connection. Following is a brief description of each number:

1. The Remote Control Controller connects to the RC Target Proxy using the proxy port specified in the `rc_def_proxy` policy method on the Spoke TMR. This policy method is only applied to the Policy Region in which the Remote Control Tool has been created. In our case the value of this port is 8888. The Controller itself uses a random port to establish a connection to port 8888 on the RC Target Proxy. This random port could also be fixed to a specific port by modifying the `rc_def_ports` policy method on the Spoke TMR. For more information on this matter, you can refer to the *IBM Tivoli Remote Control User's Guide*, SC23-4842.
2. Since this is a unidirectional configuration, we defined the RC Target Proxy to be responsible for initiating the connection to the RC Controller Proxy. In our environment the RC Target Proxy uses a random port to establish a connection to port 30008 defined on the RC Controller Proxy. This random port could also be either a fixed port or use a pre-defined range of ports. Information on how to customize it is provided in 3.3.2, "Remote Control Proxy configuration" on page 104. Communications from the RC Target Proxy machine to port 30008 should be allowed by the firewall.
3. Then the RC Controller Proxy communicates with the Endpoint Target using a random port, while the Target listens on the default Remote Control port 2501.



The ports defined as random on the Controller and RC Target Proxy could be customized specifying a single port or a range of ports, depending on the number of connections to be established. For example, we could restrict the ports usage for the communication between the RC Target Proxy Parent and all the RC Controller Proxies Children, so that the configuration on the firewall could be more restrictive. This is further explained in 3.3.2, “Remote Control Proxy configuration” on page 104.

## 3.3 Scenario installation and configuration

In this section, we describe the steps to install the Remote Control Proxies in the environment presented in Figure 3-2 on page 99, including general installation instructions and a table containing the information needed during the installation for both RC Target and RC Controller proxies. We also provide some configuration steps to complete the installation procedure.

Our testing scenario contains only one firewall. However, this scenario could be extended with a second firewall. This would create a demilitarized zone (DMZ) where the RC Target and RC Controller Proxy are not allowed to connect directly across multiple zones. In this case we could take advantage of the Relay function, provided by Tivoli Firewall Security Toolbox (TFST), which can be installed on the DMZ. The Relay would pass the information from the RC Target Proxy to the RC Controller Proxy and vice versa. Even though this new scenario would use the Relay component of the TFST, it is still considered a Remote Control StandAlone environment. For details, refer to Chapter 2, “Implementation planning” on page 57.

### 3.3.1 Remote Control Proxy installation

This section describes how to install:

- ▶ Remote Control Target Proxy
- ▶ Remote Control Controller Proxy

The installation of the Remote Control Proxy component must be done locally and can be done using either the GUI or silent methods, depending on the Install Shield mechanism. You can also take the advantage of other Tivoli Applications, such as IBM Tivoli Configuration Manager, by creating your own package with the Software Package Editor. For more information, refer to the *IBM Tivoli Configuration Manager User's Guide for Software Distribution*, SC23-4711. In addition, you can refer to the *IBM Tivoli Remote Control User's Guide*, SC23-4842 for the information about the silent installation.

The Remote Control Proxies components can be installed on any machine in your environment whether part of the TME environment or not. Refer to Chapter 2, “Implementation planning” on page 57, to check on the various supported operating systems and maintenance levels.

The Remote Control Proxies components code is shipped with the IBM Tivoli Remote Control 3.8 media, the same you used to install the IBM Tivoli Remote Control Server component. The installation process for the RC Target and RC Controller Proxies is the same and uses the same source image and path. The differences are in the configuration piece only. You can refer to Chapter 2, “Implementation planning” on page 57 for details.

In order to install the Remote Control Proxies, issue the following command:

On Windows:

```
<CD-ROM drive>\new\RCPROXY\w32-ix86\setup.exe
```

On AIX:

```
#. ./<CD-ROM drive>/new/RCPROXY/aix/install.sh ./setup.bin
```

**Note:** If the installation on UNIX never displays the GUI panel, make sure the /tmp file system is not 100% used.

Table 3-1 shows the configuration settings we used in our lab for this scenario during the RC Target Proxy installation.

Table 3-1 RC Target Proxy settings

Parameter	Description	Our settings
Local port	Port used locally by the Parent Proxy to listen to its Children	2888
Network interface	Hostname of Child Proxy or Controller Proxy listening for connections	tic01005
Port number used by child proxy	Remote port used by Child Proxy or Controller Proxy to listen for connections	30008
Connection type	Connection direction between the Parent Proxy and its Children	unidirectional
Unidirectional role	Role of this Proxy when connection is unidirectional	Initiator
Target Endpoint labels	Remote Control Target we want to control	tic01005 tic01007

Parameter	Description	Our settings
Remote Control Proxy label	Controller Proxy label where the Endpoint Target are connected to	tic01005
Proxy type	Role of the Parent RC Proxy	Target
Port number	Port on which this Proxy listens for connection from Controllers (must match with rc_def_proxy value).	8888
Command line port	Command line port (used by the <b>rcproxy</b> command)	9000

The above settings are mandatory and, once the installation is completed, all this information is stored in the `rcproxy.cfg` file located at the Remote Control Proxy installation directory. Inputs needed to modify the remote control Target Proxy configuration file are given in “The `rcproxy.cfg` configuration file” on page 104.

Table 3-2 shows the configuration settings we used in our lab for this scenario during the Remote Control Controller Proxy installation:

*Table 3-2 RC Controller Proxy settings*

Parameter	Description	Our settings
Controller Proxy label	Since the Proxy is a Child, you need to assign it a label	tic01005
Local port	Port used locally by this proxy to listen for connections	30008
Parent network interface	Parent or Relay hostname	tic01002
Port used by the Parent	Port used by the Parent or Relay to listen for connections (this is not used in a unidirectional scenario)	2888
Connection type	Connection direction between this Proxy and its Parent or Relay	unidirectional
Unidirectional role	Role of this Proxy when connection is unidirectional	listener
Proxy type	Specify the role of this RC Proxy	Controller
Command line port	Command line port (used by the <b>rcproxy</b> command)	9999

The foregoing settings are mandatory and, once the installation is completed, all this information is stored in the `rcproxy.cfg` file located at the Remote Control Proxy installation directory. Inputs to modify the RC Controller Proxy configuration file are given in “The `rcproxy.cfg` configuration file” on page 104.

### 3.3.2 Remote Control Proxy configuration

This section describes some of the configuration steps to modify the Remote Control Proxy settings. The Remote Control Proxy configuration is done at installation time and can be changed at any time by manipulating the following configuration files:

- ▶ Remote Control Proxy configuration file: `rcproxy.cfg`
- ▶ Remote Control Proxy routing table: `rcproxy.route`
- ▶ Remote Control policy method: `rc_def_proxy`

#### The `rcproxy.cfg` configuration file

The `rcproxy.cfg` file contains all the information related to the Remote Control Proxy, such as Proxy type, ports used, Parent/Children/Relay information, connection type, role, etc.

This file is located in the Remote Control Proxy installation directory that by default is `c:\Program File\Tivoli Systems\Remote Control Proxy` on Windows and `/opt/Tivoli Systems/Remote Control Proxy` on UNIX.

Example 3-5 shows the RC Target Proxy configuration file, based on the values we provided in Table 3-1 on page 102, immediately after the installation process.

#### *Example 3-5 Remote Control Target Proxy configuration file*

---

```
[log]
log-file=rcproxy.log
debug-level=3
max-size=1
[rcproxy]
proxy-port=8888
proxy-type=Target
proxy-interface=tic01002
cmdline-port=9000
[communication-layer]
children-local-host=tic01002
children-local-port=2888
children-remote-list=tic01005+30008
children-cm-type=cm-tcp-unidirectional
buffer-size=1024
[children-cm-info]
connection-mode=client
```

---

Example 3-6, instead, shows the RC Controller Proxy configuration file as result of the installation process, and the values provided in Table 3-2 on page 103.

*Example 3-6 Remote Control Controller Proxy configuration file*

---

```
[log]
log-file=rcproxy.log
debug-level=4
max-size=1
[rcproxy]
proxy-type=Controller
proxy-label=tic01005
cmdline-port=9999
[communication-layer]
parent-local-port=30008
parent-remote-host=tic01002
parent-remote-port=2888
parent-cm-type=cm-tcp-unidirectional
buffer-size=1024
[parent-cm-info]
connection-mode=server
```

---

In order to have a more restrictive security communication between the RC Target and RC Controller Proxies, we decided to define a range of ports the RC Target Proxy could communicate with the RC Controller Proxy. This can be achieved by using the `local-port-range` parameter in the `[children-cm-info]` clause of the `rcproxy.cfg` file. In our scenario, we specified a port range with only two ports (4000-4001) that will allow this RC Target Proxy, acting as Parent, to have only two Child Proxies connect to it. Example 3-7 shows the resulting `rcproxy.cfg` file on the RC Target Proxy:

*Example 3-7 Target Proxy local-port-range definition*

---

```
[log]
log-file=rcproxy.log
debug-level=3
max-size=1
[rcproxy]
proxy-port=8888
proxy-type=Target
proxy-interface=tic01002
cmdline-port=9000
[communication-layer]
children-local-host=tic01002
children-local-port=2888
children-remote-list=tic01005+30008
children-cm-type=cm-tcp-unidirectional
buffer-size=1024
```

```
[children-cm-info]
connection-mode=client
[children-cm-info]
connection-mode=client
local-port-range=4000-4001
```

---

In order to make these changes effective, we need to stop/start the RC Target Proxy service.

## The rcproxy.route routing table configuration file

The rcproxy.route file defines the route to the Target Endpoints. It contains the list of all the Targets the Controller needs to connect to and the related RC Controller Proxy which they belong to. It contains static routing table information for the Remote Control Proxy.

Example 3-8 shows the rcproxy.route file reflecting the settings used in our testing scenario:

### *Example 3-8 Remote Control Proxy routing table configuration file*

---

```
# This file contains static routing table information
# for remote control proxy
# Each line specifies an Endpoint (Target) label and the label
# of the Controller Proxy that serves it, separated by a comma like this:
# Endpoint_label,proxy_label    (ensure that there are no blank spaces
#                               between comma and entries)
#
#
# When you specify a label you can use the following
# wildcard characters:
# asterisk (*)                  to match any string
# question mark (?)            to match any single character
#
tic01005,tic01005
tic01007,tic01005
```

---

To correctly set the routing table information, you need to specify the Endpoint label and its correspondent RC Controller Proxy in each line of the *rcproxy.route* file.

This file is located in the Remote Control Proxy installation directory that by default is c:\Program File\Tivoli Systems\Remote Control Proxy on Windows and /opt/Tivoli Systems/Remote Control Proxy on UNIX.

## The rc\_def\_proxy policy method

In order to customize the Remote Control Proxy in a Standalone environment, it is necessary to modify the rc\_def\_proxy policy method accordingly. This file determines how the Remote Control Proxies usage will be done and how the Controller can connect to the Targets across the firewall.

Example 3-9 shows the settings we used in our rc\_def\_proxy policy method file:

### *Example 3-9 The rc\_def\_proxy policy method contents*

---

```
#!/bin/sh
#
# Default value: NO
echo "YES manual 9.3.4.169 8888"
exit 0
```

---

When using the StandAlone proxy mechanism, it is required to provide the following configuration information:

- ▶ Configuration type
- ▶ RC Target Proxy IP address
- ▶ RC Target Proxy port

In a Standalone scenario, the configuration type *must* always be set to manual. This means that the Controller will always use the IP address provided in the policy method to reach the RC Target Proxy. The Remote Control Proxy port identifies the port the RC Target Proxy listens for requests from the Controller, which in our scenario is 8888.

The **wgetpolm** and **wputpolm** commands are used to modify the rc\_def\_proxy policy method settings. Example 3-10 shows how to perform these changes in our testing scenario, where we use our own policy, named STDAOne, and not the default policy RemoteControl\_PDO:

### *Example 3-10 How to modify the rc\_def\_proxy policy method*

---

```
wlpol -d RemoteControl
RemoteControl_PDO
STDAOne
```

```
wgetpolm -d RemoteControl STDAOne rc_def_proxy > temp_rc_def_proxy.sh
```

modify the rc\_def\_proxy.sh accordingly to Example 3-9

```
wputpolm -d RemoteControl STDAOne rc_def_proxy < temp_rc_def_proxy.sh
```

---

### 3.3.3 Firewall configuration table

This section describes the correlation between the firewall customization and the Tivoli environment to be implemented, providing the information a firewall administrator should need in order to configure the ports properly on the firewall to make the remote control session working, for this particular scenario.

Table 3-3 shows the components that will communicate through the firewall and the ports they use in our scenario.

Table 3-3 Scenario firewall configuration table

Source		Destination		Service/ Protocol	Description/ Activity
Component	Port	Component	Port		
Target Proxy	4000-4001 (1)	Controller Proxy	30008	rcproxy/ TCP	rcproxy service used to connect to the Controller Proxy
Controller Proxy	30008	Target Proxy	4000-4001 (1)	rcproxy/ TCP	rcproxy service response to the Target service

(1) Defined by the local-port-range parameter, as described in the Example 3-7, the Port field should be in the range (4000-4001).

The schema provided in the previous table would allow for a data flow shown in Figure 3-4.

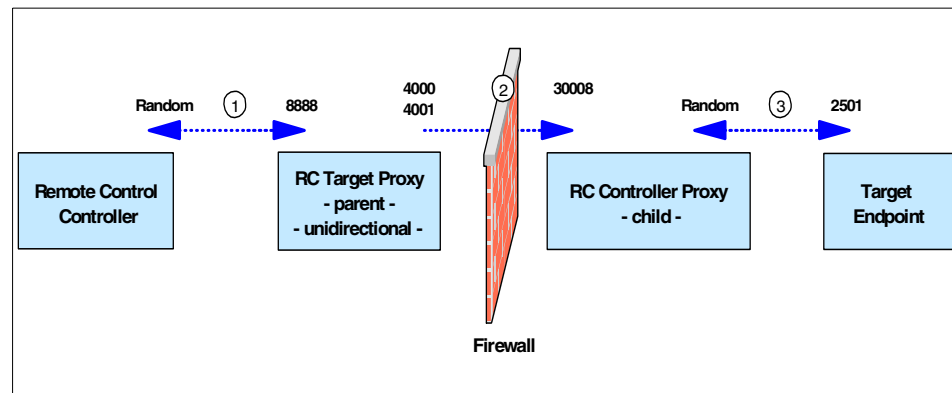

Figure 3-4 Remote Control Data Flow Overview



### 3.3.4 Remote Control Proxy startup

This section describes how you can start up the Remote Control Proxies.

Once the installation has been completed, the RC Target and RC Controller proxies have been properly configured and the firewall administrator has granted the access to ports needed by the Tivoli application to work properly, then you can check if the proxy mechanism works by starting the RC Target and RC Controller Proxy services.

By default, after a successful installation of Remote Control Proxy, the proxy service is automatically started. Actually, both RC Target and RC Controller Proxy can be started using the **rcproxy** command provided with the installation of the Proxy component.

For more information, you can refer to the *IBM Tivoli Remote Control User's Guide*, SC23-4842.

Example 3-11 shows how to startup the remote control proxy on AIX machine:

*Example 3-11 Startup of Remote Control Proxy on AIX operating system*

---

```
# pwd
/usr/local/Tivoli/Remote Control Proxy
# ./rcproxy &
[2] 17186
# 03/01/29 14:33:04 0 1 Log level: 3
03/01/29 14:33:04 0 1 Log file name: rcproxy.log
03/01/29 14:33:04 0 1 Maximum log size: 1 (MB)
#
```

---

In order to start the RC Proxy service installed on Windows 2000, you need to issue the **rcproxy** command. Figure 3-5 shows Service Applet window with the Remote Control Proxy service status.

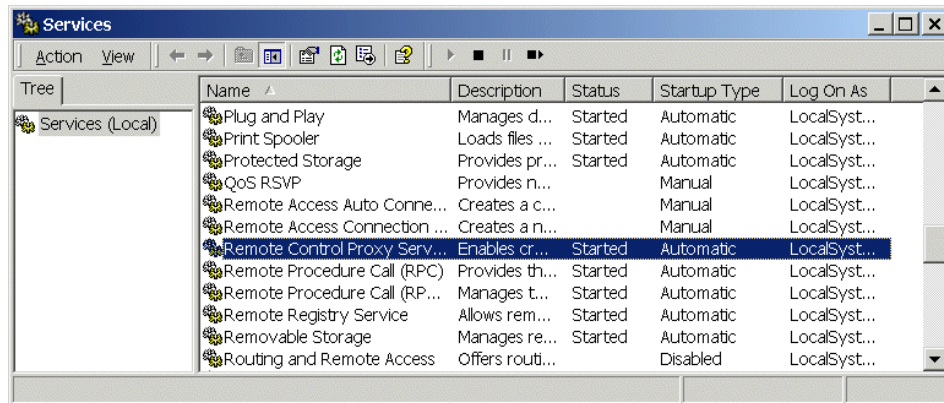

Figure 3-5 Startup of Remote Control Proxy using Service Applet

The command **rcproxy** can also be used for other tasks, such as to check how many proxy connections are active, to stop the Proxy service and to kill any of the active Proxy sessions.

Once the Target and Controller Proxy are up and running, their communication can be checked in two ways:

- ▶ Checking the `rcproxy.log` file
- ▶ Running the **netstat** command

Example 3-12 and Example 3-13 show the `rcproxy.log` files contents for RC Target and RC Controller Proxy components. The last few lines of each of the logs show that the connections are working and that the communication has been established through the firewall:

Example 3-12 The `rcproxy.log`: RC Target Proxy log file

---

```

03/02/11 09:56:05 0 1 Proxy interface: tic01002 (9.3.4.169)
03/02/11 09:56:05 0 1 Proxy listen port: 8888
03/02/11 09:56:05 0 1 No TFST Endpoint proxy directory, working in
standalone mode
03/02/11 09:56:05 2 1 No timeout specified, using default
03/02/11 09:56:05 0 1 Communication timeout: 240
03/02/11 09:56:05 0 1 Max sessions: 10
03/02/11 09:56:05 0 1 Reply to RSM data: no
03/02/11 09:56:05 2 1 initRoutedSessionsManager: children-remote-file
parameter not specified
03/02/11 09:56:05 3 772 routingManager: TELL command received [l=tic01005]
03/02/11 09:56:05 3 772 routingManager: WHO reply command received
[l=tic01005]

```

---

*Example 3-13 The rcproxy.log: RC Controller Proxy log file*

```
03/02/11 09:54:07 0 1228 Proxy label: tic01005
03/02/11 09:54:07 0 1228 Proxy type: Controller
03/02/11 09:54:07 2 1228 No timeout specified, using default
03/02/11 09:54:07 0 1228 Communication timeout: 240
03/02/11 09:54:07 0 1228 Max sessions: 10
03/02/11 09:54:07 0 1228 Reply to RSM data: no
03/02/11 09:54:07 3 1228 initRoutedSessionsManager: no network card specified
for parent-local-host, using random interface
03/02/11 09:54:33 3 1760 routingManager: WHO command received [1=null]
03/02/11 09:54:33 3 1760 routingManager: TELL reply command received
```

In order to check which ports these Proxies are using to communicate and to verify that no other ports are actually being used, we can use any network status command, such as **netstat -a** command or similar. Example 3-14 and Example 3-15 show the output of the **netstat -a** command on both the RC Target Proxy and RC Controller Proxy.

*Example 3-14 The netstat output collected on the RC Target Proxy*

```
Active Internet connections (including servers)
Proto Recv-Q Send-Q Local Address           Foreign Address         (state)

Active Internet connections (including servers)
Proto Recv-Q Send-Q Local Address           Foreign Address         (state)
tcp4      0      0 tic01002.32781         tic01002.601           ESTABLISHED
tcp4      0      0 tic01002.601           tic01002.32781         ESTABLISHED
tcp4      0      0 tic01002.32781         tic01002.602           ESTABLISHED
tcp4      0      0 tic01002.602           tic01002.32781         ESTABLISHED
tcp4      0      0 tic01002.32781         tic01002.651           ESTABLISHED
tcp4      0      0 tic01002.651           tic01002.32781         ESTABLISHED
tcp4      0      0 tic01002.32781         tic01002.718           ESTABLISHED
tcp4      0      0 tic01002.718           tic01002.32781         ESTABLISHED
tcp4      0      0 tic01002.32781         tic01002.766           ESTABLISHED
tcp4      0      0 tic01002.766           tic01002.32781         ESTABLISHED
tcp4      0      0 tic01002.32781         tic01002.784           ESTABLISHED
tcp4      0      0 tic01002.784           tic01002.32781         ESTABLISHED
tcp4      0      0 tic01002.32781         tic01002.812           ESTABLISHED
tcp4      0      0 tic01002.812           tic01002.32781         ESTABLISHED
tcp4      0      0 tic01002.32769         tic01002.830           ESTABLISHED
tcp4      0      0 tic01002.830           tic01002.32769         ESTABLISHED
tcp4      0      0 tic01002.32769         tic01002.832           ESTABLISHED
tcp4      0      0 tic01002.832           tic01002.32769         ESTABLISHED
tcp4      0      0 tic01002.32769         tic01002.833           ESTABLISHED
tcp4      0      0 tic01002.833           tic01002.32769         ESTABLISHED
tcp4      0      0 tic01002.32769         tic01002.834           ESTABLISHED
tcp4      0      0 tic01002.834           tic01002.32769         ESTABLISHED
tcp4      0      0 tic01002.32781         tic01002.926           ESTABLISHED
```

tcp4	0	0	tic01002.926	tic01002.32781	ESTABLISHED
<b>tcp4</b>	<b>0</b>	<b>0</b>	<b>tic01002.4000</b>	<b>tic01005.30008</b>	<b>ESTABLISHED</b>
tcp4	0	0	tic01002.42982	tic01002.42983	ESTABLISHED
tcp4	0	0	tic01002.42983	tic01002.42982	ESTABLISHED
tcp4	0	0	tic01002.55345	tic01002.55346	ESTABLISHED
tcp4	0	0	tic01002.55346	tic01002.55345	ESTABLISHED
tcp4	0	0	tic01002.objcall	tic01010.38466	ESTABLISHED
tcp4	0	0	tic01002.8888	*,*	LISTEN

---

*Example 3-15 The netstat output collected on the Controller Proxy*

---

Active Connections

Proto	Local Address	Foreign Address	State
TCP	tic01005:ftp	tic01005:0	LISTENING
TCP	tic01005:epmap	tic01005:0	LISTENING
TCP	tic01005:microsoft-ds	tic01005:0	LISTENING
TCP	tic01005:1025	tic01005:0	LISTENING
TCP	tic01005:1027	tic01005:0	LISTENING
TCP	tic01005:1077	tic01005:0	LISTENING
TCP	tic01005:1272	tic01005:0	LISTENING
TCP	tic01005:1855	tic01005:0	LISTENING
TCP	tic01005:2107	tic01005:0	LISTENING
TCP	tic01005:2111	tic01005:0	LISTENING
TCP	tic01005:2118	tic01005:0	LISTENING
TCP	tic01005:2119	tic01005:0	LISTENING
TCP	tic01005:2688	tic01005:0	LISTENING
TCP	tic01005:3508	tic01005:0	LISTENING
TCP	tic01005:6000	tic01005:0	LISTENING
TCP	tic01005:30008	tic01005:0	LISTENING
<b>TCP</b>	<b>tic01005:30008</b>	<b>tic01002:4000</b>	<b>ESTABLISHED</b>
TCP	tic01005:9999	tic01005:0	LISTENING

---

The highlighted lines in Example 3-14 and Example 3-15 show the connection between the RC Proxies components.

Also notice that the both netstat outputs were collected *before* any remote control session was actually started

Example 3-16 lists the output of the **rcproxy** command, showing no active connections:

*Example 3-16 The output of the rcproxy -list command*

---

```
# ./rcproxy -list
total sessions = 0
03/02/11 10:27:30 0    1 releaseLock [id=0x2020bfd8] - pthread_mutex_unlock()
failed (e=1)
03/02/11 10:27:30 0    1 releaseLock [id=0x2020bf98] - pthread_mutex_unlock()
failed (e=1)
```

---

An example of **netstat** and **rcproxy -list** commands output during an active session is provided in the section “Remote Control Proxy startup” on page 133.

**Attention:** The **rcproxy** command included in Example 3-16 shows some error messages that can be ignored. That is because the RC Proxies are not installed on top of the TFST Proxies (Endpoint Proxy or Gateway Proxy).





## Implementation scenario: Tivoli Firewall Security Toolbox

In this chapter we describe the techniques used to implement IBM Tivoli Remote Control 3.8 in a firewall environment. The scenario we present will help you understand the requirements for establishing Remote Control sessions when firewall is involved, using a more secure mechanism, the Remote Control Proxy technology using the Tivoli Firewall Security Toolbox. These topics are covered:

- ▶ Our testing scenario: Remote Control Proxies implementation using the Tivoli Firewall Security Toolbox (TFST) environment
- ▶ Data flow, TCP/IP ports used, and firewall configuration
- ▶ Remote Control Proxies installation and configuration

We make the following assumptions:

- ▶ You have a working knowledge of the TME architecture and of the IBM Tivoli Management Framework 4.1
- ▶ You have a basic understanding of Tivoli Firewall Security Toolbox 1.3 (TFST). Appendix A, “Tivoli Firewall Security Toolbox overview” on page 175 provides an overview of the main TFST components.
- ▶ You have a basic understanding of large enterprise network architecture, firewall and proxies.

## 4.1 Scenario overview

In this section we provide an overview of our Remote Control Non-Standalone testing scenario. A typical Remote Control Non-Standalone architecture is implemented when the firewall stands between the Endpoint Targets and the Endpoint Gateway. A common environment, for example, could be managing the Endpoint in the DMZ with the Gateway located at the most secured zone.

The goal of this scenario is to provide detailed information to the System Administrator of the requirements and considerations that will help him to work with session management across the firewall. We provide as much information as possible to deeply describe the implementation of Remote Control using the TFST component functionalities. We also show a diagram outlining the data flow mechanism and include the firewall configuration tables in order to allow the successful usage of IBM Tivoli Remote Control across the firewalls.

In this testing scenario we assume that the IBM Tivoli Management Framework 4.1 and the Tivoli Firewall Security Toolbox 1.3 have been properly installed and configured and that any down call to the Endpoint can be successfully executed as the up call to the Gateway. You can refer to the Firewall Security Toolbox User's Guide, GC23-4826 if you have any problems in this area. Moreover, we assume you have already installed and configured the Endpoint Proxy, Relay, and Gateway Proxy components, and that the communication works from the Framework point of view.

These are the basic requirements before configuring and installing IBM Tivoli Remote Control across firewalls. We assume that IBM Tivoli Remote Control 3.8 server component is already installed on the TMR and all Tivoli Gateways hosting the Endpoints, controllers and Targets. Refer to *IBM Tivoli Remote Control User's Guide*, SC23-4842 for details.

## 4.2 Environment description

In our testing scenario, the goal was to reproduce the most common environment using all the required components in order to provide valuable inputs and illustrate our conclusions. We used different machine types and operating systems. Even though the goal here is not to test firewall products, we used different firewall products with this configuration, keeping in mind the services, protocol, and ports used by the Remote Control Proxies.



We demonstrate how the Remote Control Proxy will allow remote control connections through the firewall with minimal impact on the connection policies enforced by the firewall itself. We explain the seamless integration the Remote Control Proxies have with the Tivoli Firewall Security Toolbox and its ability to handle concurrent sessions.

Complex network may impose the usage of Remote Control across multiple firewalls. Since Remote Control uses the TFST technology, it can take advantage of the Relay component of TFST to bridge two proxies across multiple firewalls. Relays cannot be shared in integrated scenario between Remote Control Proxy and TFST, so we need to have two different Relay entities; one will be used by the Remote Control Proxy, and the other one by the TFST. In this case it is necessary to install another Relay instance on the environment. All those Relay instances *must* be installed on the *same* physical machine. For additional information, refer to Chapter 2, “Implementation planning” on page 57.

### 4.2.1 Technical infrastructure

This section provides a detailed description of our TFST environment, showing the machine type, operating system, and Tivoli resources we installed on each machine.

Figure 4-1 illustrates the general testing scenario used in our lab.

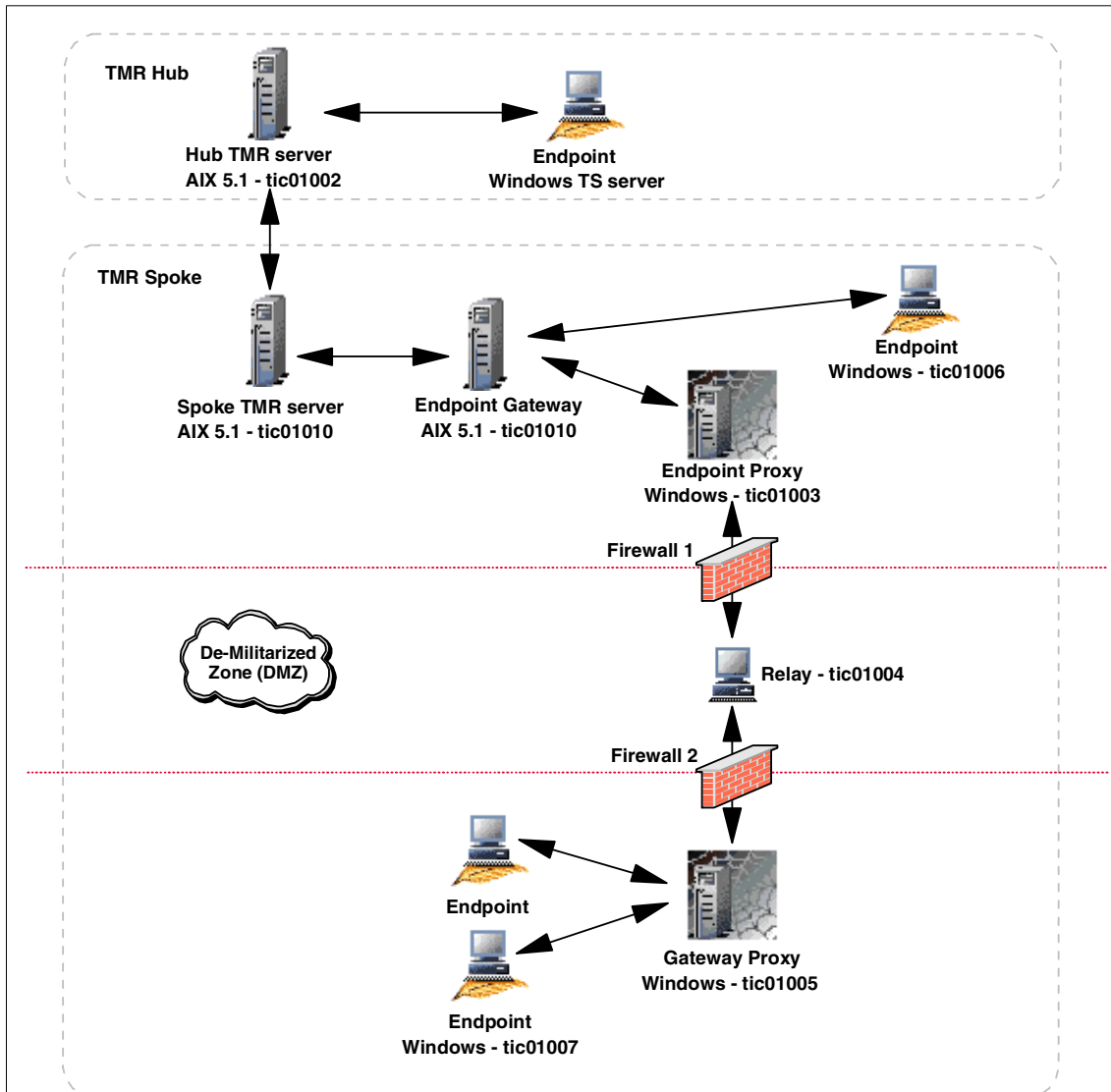

Figure 4-1 General TFST testing scenario

In our testing scenario we have defined two firewalls dividing the Tivoli environment into three zones: a more secure zone where all TMR Servers and Endpoint Gateways reside, a De-Militarized Zone (DMZ), and a less secure zone where the Targets Endpoints are located.

For our testing we used the following products and release levels:

- ▶ Operating systems:
  - IBM AIX 5.1
  - Microsoft Windows 2000 Advanced Server
  - Microsoft Windows 2000 Professional
- ▶ Tivoli Software:
  - IBM Tivoli Management Framework 4.1
  - IBM Tivoli Remote Control 3.8
  - Tivoli Firewall Security Toolbox 1.3

We interconnected the Hub and Spoke TMR, using a two-way connection, and exchanged the following Tivoli resources:

- ▶ Administrator (two-way)
- ▶ AdministratorCollection (two-way)
- ▶ ManagedNode (two-way)
- ▶ Endpoint (two-way)
- ▶ PolicyRegion (two-way)
- ▶ ProfileManager (two-way)
- ▶ EndpointManager (one-way, and only once from the Spoke to the HUB TMR)

**Note:** We have not exchanged the Remote Control resource because, in our scenario, there are no controllers connected to the HUB TMR.

For this scenario, we assume that all Administrators are on the more secure side of our network. Therefore, the Remote Control Server is installed on both of the TMR Servers; and one of the Endpoints in the more secure zone will be the Remote Control Controller. The Administrators need to have remote Control access to the Endpoint located in the less secure zone.

Figure 4-2 shows how we implemented the Remote Control Proxy technology based on the existing TFST configuration.

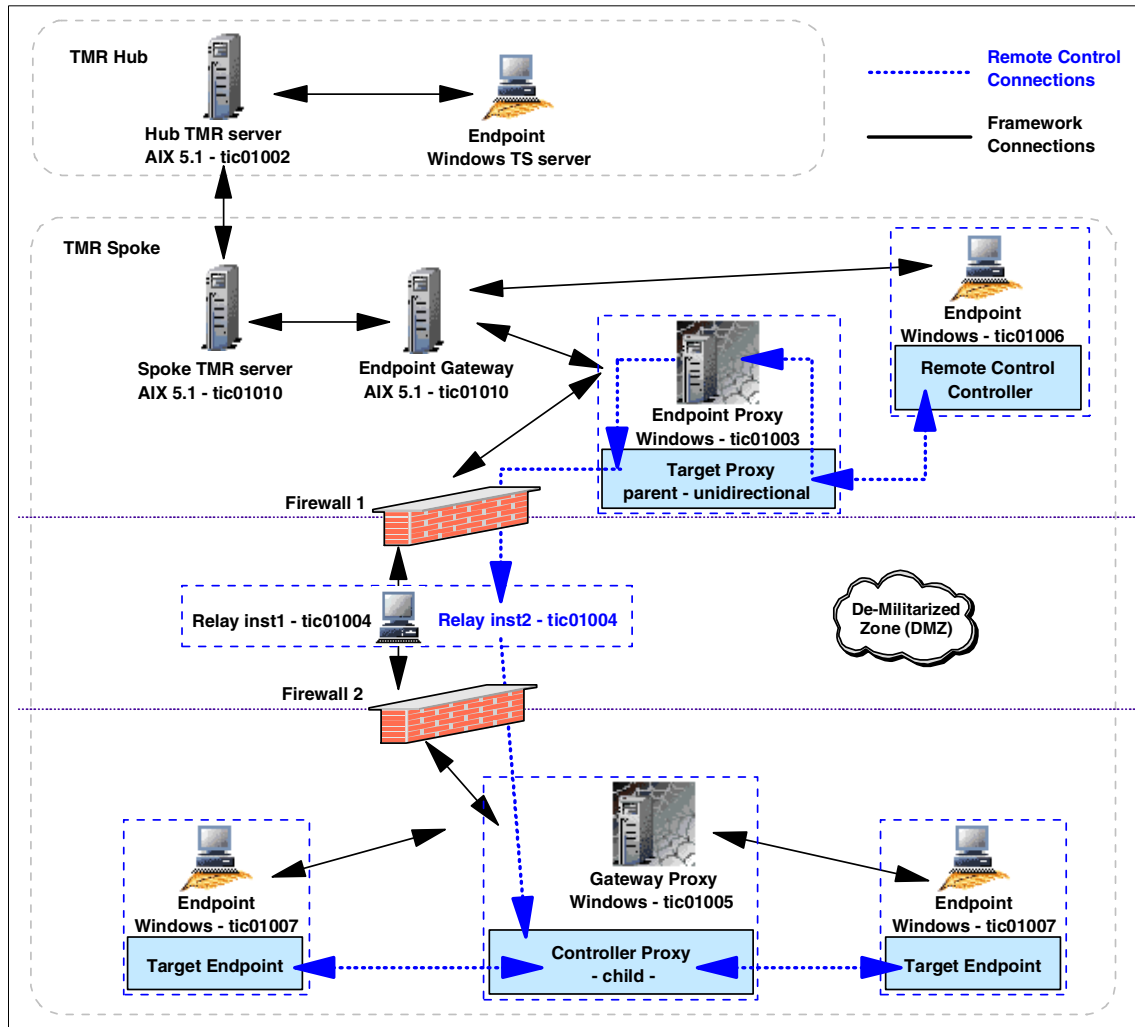

Figure 4-2 Remote Control Proxy Implementation in a TFST environment

Based on Figure 4-2, we configured our testing scenario as follows:

- ▶ An RC Target Proxy needs to be installed on the same machine as the Endpoint Proxy. Because this Endpoint Proxy is a Parent in the TFST structure, this RC Target Proxy automatically becomes a Parent.
- ▶ Per security guidelines, the communication is defined as unidirectional. Therefore, only the RC Target Proxy on the secure zone can be the connection initiator.

- ▶ Since there is a Relay placed in the DMZ to allow the proxies communication across multiple firewalls (Endpoint Proxy in the more secure side and the Gateway Proxy in the less secure side), we need to define an extra Relay instance on this network that will allow the communication between the RC Target Proxy and the RC Controller Proxy. This Relay will be configured as a Child of the RC Target Proxy and a Parent of the RC Controller Proxy.
- ▶ An RC Controller Proxy needs to be installed on the same machine as the Gateway Proxy. This RC Controller Proxy will be configured to be a Child of the second instance of the Relay. Because the RC Controller Proxy is running on the Gateway Proxy machine, its label should be exactly the same as the Gateway Proxy.
- ▶ Since the communication is defined as unidirectional, and the RC Target Proxy is the initiator, the RC Controller Proxy will be defined as listener.

Table 4-1 shows a summary of the configuration of our environment, providing hostname, operating system, and related Tivoli resources installed.

*Table 4-1 Summary of Framework and Remote Control resources*

Hostname	Operating system	Tivoli resource	Remote control resource
tic01010	AIX 5.1	TMR Spoke and Gateway	Remote Control Server
tic01003	Windows 2000 Server	Endpoint Proxy	RC Target Proxy
tic01004	Windows 2000 Server	Relay	Relay
tic01005	Windows 2000 Server	Gateway Proxy	RC Controller Proxy
tic01006	Windows 2000 Professional	Endpoint	Remote Control Controller
tic01007	Windows 2000 Professional	Endpoint	Remote Control Target

## 4.2.2 Data flow description

This section provides a description of the data flow in our network topology, based on our testing scenario, and also highlights the ports used for the communication between each RC Proxy and TFST component, preparing the basis for 4.2.3, “Firewall configuration tables” on page 124.

The schema reported in Figure 4-3 shows an overview of the data flow in our Non-Standalone case study scenario.

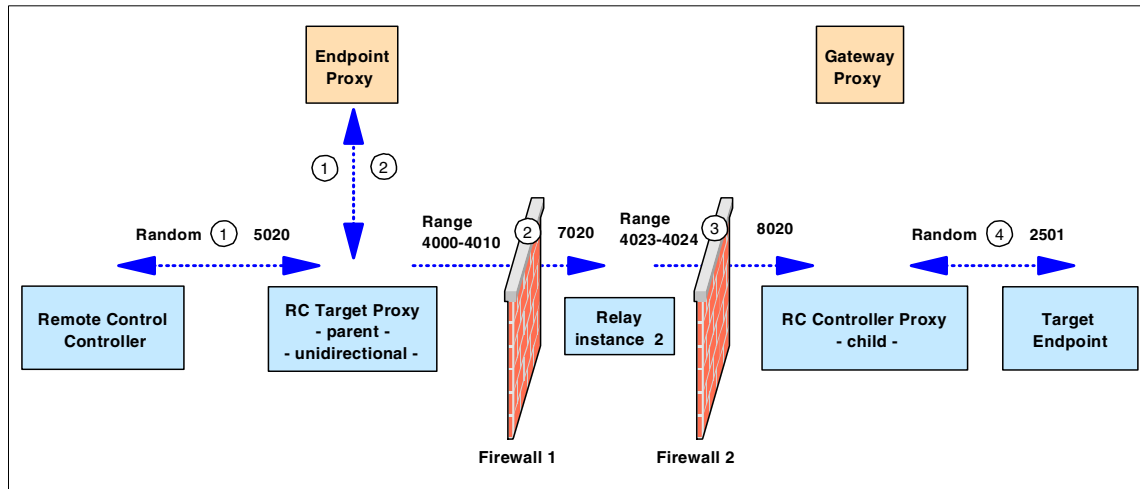

Figure 4-3 Data flow overview: Non-Standalone scenario

To briefly describe how the data flow structure is, we numbered each connection reported in Figure 4-3 specifying the ports required to establish each connection. Follow a brief description of each number:

1. The Remote Control Controller connects to the RC Target Proxy using the proxy port specified in the `rc_def_proxy` policy method on the Spoke TMR. This policy method is only applied to the Policy Region in which the Remote Control Tool has been created. In our case the value of this port is 5020. The Controller itself uses a random port to establish a connection to port 5020 on the RC Target Proxy. This random port could also be fixed to a specific port by modifying the `rc_def_ports` policy method on the Spoke TMR. For more information on this matter you can refer to the *IBM Tivoli Remote Control User's Guide*, SC23-4842. The RC Target Proxy contacts the Endpoint Proxy to find out the path to the requested Target.
2. The Endpoint Proxy then provides to the RC Target Proxy the hostname of the Gateway Proxy responsible for that Target. The RC Target Proxy uses that information to initiate the connection to the RC Controller Proxy. In our environment the RC Target Proxy uses a pre-defined range of ports (4000-4010) to establish a connection to port 7020 defined on the second instance of the Relay. This range of ports need to be defined *after* the installation of the RC Target Proxy. Information on how to customize it will be provided in 4.3.2, "Remote Control Proxy configuration" on page 129. Communications from the RC Target Proxy machine to port 7020 should be allowed by firewall 1.

3. The second instance of the Relay is then responsible for initiating the connection with the RC Controller Proxy. This Relay uses a pre-defined range of ports (4023-4024) to establish a connection to port 8020 defined on the RC Controller Proxy. This range of ports needs to be defined *after* the installation of the second instance of the Relay. Information on how to customize it is given in 4.3.2, “Remote Control Proxy configuration” on page 129. Communications from the RC Target Proxy machine to port 7020 should be allowed by firewall 2.
4. Then the RC Controller Proxy communicates with the Endpoint Target using a random port, while the Target listens on the default Remote Control port 2501.

Table 4-2 summarize the ports that we used to configure both Remote Control Proxies and the Relay.

*Table 4-2 Summary of port configuration*

Source		Destination	
Component	Port	Component	Port
Controller	random	RC Target Proxy	5020
RC Target Proxy	range (4000-4010)	Relay	7020
Relay	range (4023-4024)	RC Controller Proxy	8020
RC Controller Proxy	random	Target	2501
Target	2501	RC Controller Proxy	random
RC Controller Proxy	8020	Relay	range (4023-4024)
Relay	7020	RC Target Proxy	range (4000-4010)
RC Target Proxy	5020	Controller	random

When a remote Control session is initiated, the Remote Control Controller connects to the RC Target Proxy running on the Endpoint Proxy machine. When the Target Endpoint is connected to a Gateway Proxy, it is registered in the Endpoint Manager using the Endpoint Proxy IP address. The RC Target Proxy queries the Endpoint Proxy about the actual Endpoint’s IP address and port and collects this information. The Endpoint Proxy also gives the Gateway Proxy label to the RC Target Proxy.

Since this label must be the same as the Controller Proxy, the RC Target Proxy also knows the Controller Proxy it needs to connect to. The RC Target Proxy then forwards the request to the RC Controller Proxy through the specified Relay instance. When the request is received by the RC Controller Proxy, it will be responsible for connecting to the IP address and port number of the Endpoint Target it has just collected.

### 4.2.3 Firewall configuration tables

This section provides a correlation between firewall customization and the Tivoli environment to be implemented, providing the information a firewall administrator should need in order to configure the ports properly on all the firewalls to make the remote control session working, for this particular scenario.

Table 4-3 shows the components that will communicate through firewall 1 and the ports they use in our scenario.

*Table 4-3 Firewall 1 configuration table*

Source		Destination		Service/ Protocol	Description/ Activity
Component	Port	Component	Port		
RC Target Proxy	range (4000-4010)	Relay	7020	rcproxy / TCP	RC Target Proxy service
Relay	7020	RC Target Proxy	range (4000-4010)	Relay / TCP	Relay service

Table 4-4 shows the components that will communicate through firewall 2 and the ports they use in our scenario.

*Table 4-4 Firewall 2 configuration table*

Source		Destination		Service/ Protocol	Description/ Activity
Component	Port	Component	Port		
Relay	range (4023-4024)	Controller Proxy	8020	Relay	Relay service
Controller Proxy	8020	Relay	range (4023-4024)	rcproxy	RC Controller Proxy service



The port range must have as many ports as the number of Child Proxies the related proxy has. In our example we assume that the RC Target Proxy could have up to 10 additional Child Proxies, while the Relay could have 2 Child Proxies.

## 4.3 Scenario installation and configuration

This section describes scenarios for installing RC Target and Controller Proxies in our Non-Standalone environment. It also includes the configuration steps needed in order to properly customize the Proxies and to allow the Remote Control sessions across firewalls, according to the settings given in 4.2.3, “Firewall configuration tables” on page 124. The installation is performed based on the environment presented in Figure 4-2 on page 120.

### 4.3.1 Remote Control Proxy installation

This section describes how to install:

- ▶ Remote Control Target Proxy
- ▶ Relay instance used by Remote Control
- ▶ Remote Control Controller Proxy

The installation of the Remote Control Proxy component must be done locally and can be done using either the GUI or silent methods depending on the Install Shield mechanism. You can also take the advantage of other Tivoli Applications, such as IBM Tivoli Configuration Manager creating your own package with the Software Package Editor. For more information, see the *IBM Tivoli Configuration Manager User's Guide for Software Distribution*, SC23-4711. In addition, you can refer to the *IBM Tivoli Remote Control User's Guide*, SC23-4842 for information about the silent installation.

The installation procedure for the RC Target and Controller Proxies are the same as we presented for the StandAlone scenario as described in the 3.3.1, “Remote Control Proxy installation” on page 101. However, the RC Target Proxy must be installed on the same machine as the Endpoint Proxy, and the RC Controller Proxy must be installed on the same machine as the Gateway Proxy.

The Remote Control Proxies components code is shipped with the IBM Tivoli Remote Control 3.8 media, the same that you used to install the IBM Tivoli Remote Control Server component. The installation process for the RC Target and RC Controller Proxies is the same and uses the same source image and path. The differences are in the configuration piece only. You can refer to Chapter 2, “Implementation planning” on page 57 for details.

## RC Target Proxy installation

In our testing scenario the RC Target Proxy component should be installed on Windows 2000 Server operating system. The installation is performed using the Install Shield mechanism running the **setup.exe** command from the IBM Tivoli Remote Control 3.8 media as follows:

```
<CD-ROM drive>\new\RCPROXY\w32-ix86\setup.exe
```

As soon as the installation process starts, it automatically detects the TFST code already installed on the machine. Since this installation detects an Endpoint Proxy installation, the RC Target Proxy will be automatically configured as a Parent Proxy.

Table 4-5 shows the configuration settings we used in our lab for this scenario during the RC Target Proxy installation.

Table 4-5 RC Target Proxy installation settings

Parameter	Description	Our settings
Local port	Port used locally by the Parent Proxy to listen from its Children (*)	6020 (*)
Network interface	Hostname of Child Proxy or RC Controller Proxy listening for connection	tic01004
Port number used by Child Proxy	Remote port used by Child Proxy or RC Controller Proxy to listen for connections	7020
Connection type	Connection direction between the Parent Proxy and its Children	unidirectional
Unidirectional role	Role of Parent Proxy when connection is unidirectional: - Initiator (client) - Listener (server)	initiator
Proxy type	Role of the Parent RC Proxy	Target
Port number	Port on which this Proxy listens for connection from Controllers and RC Controller Proxy (must match with value in rc_def_proxy policy)	5020
Command line port	Command line port on which this Proxy listens for request (used by the <b>rcproxy</b> command)	3333
(*) This parameter is mandatory during the installation. Since the connection type is unidirectional and the RC Target Proxy is configured as initiator, port 6020 will never be used.		

For additional information related to the Remote Control Proxy installation you can refer to the *IBM Tivoli Remote Control User's Guide*, SC23-4842.

## Relay instance used by Remote Control

In our testing scenario we have to install a second instance of the Relay to be used that will bridge the RC Target and Controller Proxies. The installation of the Relay component is started by the **TivoliRelay.exe** command provided by the Tivoli Firewall Security Toolbox 1.3 included in the IBM Tivoli Management Framework 4.1 media. On Windows 2000 Advanced Server, issue the following command:

```
<CD-ROM>\tier1\new1\FST\Relay\w32-ix86\TivoliRelay.exe
```

Table 4-6 shows the configuration settings we used in our lab for this scenario during the Relay installation.

*Table 4-6 Relay instance installation settings*

Parameter	Description	Our settings
Relay port	Port used by the Relay to communicate with the Parent	7020
Relay or Endpoint Proxy hostname	Hostname of Endpoint Proxy or Parent Relay	tic01003
Relay or Endpoint Proxy port	Port number of the Parent Relay or Endpoint Proxy which this Relay will communicate (*)	6020 (*)
Connection type	Connection direction between the Relay and its Parent	unidirectional
Unidirectional role in relation to the RC Target Proxy	Role of Relay when connection is unidirectional: - Initiator (client) - Listener (server)	listener
Relay-port (Children session)	Port used by the Relay to communicate with its Child	7021
Relay or Gateway Proxy	The hostname of the Relay or Gateway Proxy machine where this Relay connects to	tic01005
Relay or Gateway Proxy port	Port of the machine where this Relay connects to	8020
Connection type	Connection direction between the Relay and its Child	unidirectional

Parameter	Description	Our settings
Unidirectional role in relation to the RC Controller Proxy	Role of Relay when connection is unidirectional: - Initiator (client) - Listener (server)	initiator
(*) This parameter is mandatory during the installation. Since the connection type is unidirectional and the Relay is configured as listener, port 6020 will never be used.		

## RC Controller Proxy installation

In our testing scenario the RC Controller Proxy component should be installed on the Windows 2000 Server operating system. The installation is performed using the Install Shield mechanism running the **setup.exe** command from the IBM Tivoli Remote Control 3.8 media as follows:

```
<CD-ROM drive>\new\RCPROXY\w32-ix86\setup.exe
```

As soon as the installation process starts, it automatically detects the TFST code already installed on the machine. Since this installation detects a Gateway Proxy installation, the RC Controller Proxy will be automatically configured as a Child Proxy. In addition to that, the Gateway Proxy and the RC Controller Proxy share some TFST libraries and therefore they must have the same label.

Table 4-7 shows the configuration settings we used in our lab for this scenario during the RC Controller Proxy installation.

*Table 4-7 RC Controller Proxy installation settings*

Parameter	Description	Our settings
Local port	Port used to listen for connections	8020
Network interface	Hostname of Parent Proxy or Relay	tic01004
port number used by Child proxy	Port used by Parent Proxy or Relay to listen for connections	7021
Connection type	Connection direction between the Parent Proxy and its Children	unidirectional
Unidirectional role	Role of Parent Proxy when connection is unidirectional: - Initiator (client) - Listener (server)	listener
Proxy type	Role of this Remote Control Proxy	Controller
Command line port	Command line port on which this Proxy listens for request (used by the <b>rcproxy</b> command)	3333

After installing the RC Controller Proxy, all the settings are stored in the `rcproxy.cfg` file placed in the installation path directory. The file contents appear as shown in the Example 4-1.

*Example 4-1 RC Controller Proxy configuration file*

---

```
[log]
log-file=rcproxy.log
debug-level=3
max-size=1
[rcproxy]
proxy-label=tic01005-gw
proxy-type=controller
cmdline-port=3333
[communication-layer]
parent-local-port=8020
parent-remote-host=tic01004
parent-remote-port=7021
parent-cm-type=cm-tcp-unidirectional
buffer-size=1024
[parent-cm-info]
connection-mode=server
```

---

In our testing scenario we configured our Gateway Proxy machine specifying its label to the value `tic01005-gw`. As you can see from the example above, the Proxy label of our RC Controller Proxy is the same as the Gateway Proxy. This is automatically set by the installation process when we install the Controller Proxy, since the installation detects the TFST installation on the Controller Proxy machine and picks up this information.

### 4.3.2 Remote Control Proxy configuration

This section describes some of the configuration steps to modify the Remote Control Proxy settings. The Remote Control Proxy configuration is done at installation time and can be changed at any time by manipulating the following configuration files:

- ▶ Remote Control Proxy configuration file: `rcproxy.cfg`
- ▶ Relay configuration file: `Relay.cfg`
- ▶ Remote Control policy method: `rc_def_proxy`

#### The `rcproxy.cfg` configuration file

The `rcproxy.cfg` file contains all the information related to the Remote Control Proxy, such as Proxy type, ports used, Parent/Children/Relay information, connection type, role, etc.

This file is located in the Remote Control Proxy installation directory that, by default, is c:\Program File\Tivoli Systems\Remote Control Proxy on Windows and /opt/Tivoli Systems/Remote Control Proxy on UNIX.

Example 4-2 shows the RC Target Proxy configuration file based on the values we provided in Table 4-5 on page 126 immediately after the installation process.

*Example 4-2 RC Target Proxy configuration file example*

---

```
[log]
log-file=rcproxy.log
debug-level=3
max-size=1
[rcproxy]
epp-directory=C:\Tivoli\Tivoli Systems\Tivoli Endpoint Proxy
proxy-port=5020
proxy-type=Target
cmdline-port=3333
[communication-layer]
Children-local-port=6020
Children-remote-list=tic01004+7020
Children-cm-type=cm-tcp-unidirectional
buffer-size=1024
[Children-cm-info]
connection-mode=client
```

---

In order to have a more restrictive security communication between the RC Target and Relay, we decided to define a range of ports the RC Target Proxy could communicate with the Relay. This can be achieved by using the `local-port-range` parameter in the `[children-cm-info]` clause of the `rcproxy.cfg` file. In our scenario, we specified a port range with only 11 ports (4000-4010) that will allow this RC Target Proxy, acting as Parent, to have up to 11 Child Proxies connect to it. Example 4-3 shows the resulting `rcproxy.cfg` file on the RC Target Proxy:

*Example 4-3 Modification settings example*

---

```
[log]
log-file=rcproxy.log
debug-level=3
max-size=1
[rcproxy]
epp-directory=C:\Tivoli\Tivoli Systems\Tivoli Endpoint Proxy
proxy-port=5020
proxy-type=Target
cmdline-port=3333
[communication-layer]
Children-local-port=6020
```

```
Children-remote-list=tic01004+7020
Children-cm-type=cm-tcp-unidirectional
buffer-size=1024
[Children-cm-info]
connection-mode=client
local-port-range=4000-4010
```

---

In order to make these changes effective we need to stop/start the RC Target Proxy service.

## The Relay.cfg configuration file

The relay.cfg file contains all the information related to the Relay settings we specified during the Relay component installation,. This file is located in the Relay installation directory and can be modified at any time. Example 4-4 shows the Relay configuration file based on the values we provided in Table 4-6 on page 127 immediately after the installation process.

### *Example 4-4 The Relay.cfg after the installation*

---

```
[communication-layer]
Children-local-port=7021
Children-remote-list=tic01005+8020
parent-local-port=7020
parent-remote-host=tic01003
parent-remote-port=6020
parent-cm-type=cm-tcp-unidirectional
Children-cm-type=cm-tcp-unidirectional
[log]
log-file=Relay.log
debug-level=3
max-size=1
[parent-cm-info]
connection-mode=server
[Children-cm-info]
connection-mode=client
```

---

In order to have a more restrictive security communication between the Relay and the RC Controller Proxy, we decided to define a range of ports the RC Target Proxy could communicate with the Relay. Similarly to the RC Proxies, this can be achieved by using the `local-port-range` parameter in the `[children-cm-info]` clause of the `Relay.cfg` file. In our scenario, we specified a port range with only 2 ports (4023-4024) that will allow this Relay to act as Parent for up to 2 Child Proxies. Example 4-5 shows the resulting `rcproxy.cfg` file on the Relay:

*Example 4-5 The Relay.cfg file after the changes*

---

```
[communication-layer]
Children-local-port=7021
Children-remote-list=tic01005+8020
parent-local-port=7020
parent-remote-host=tic01003
parent-remote-port=6020
parent-cm-type=cm-tcp-unidirectional
Children-cm-type=cm-tcp-unidirectional
[log]
log-file=Relay.log
debug-level=3
max-size=1
[parent-cm-info]
connection-mode=server
[Children-cm-info]
connection-mode=client
local-port-range=4023-4024
```

---

In order to make these changes effective we need to stop/start the Relay service.

### **The rc\_def\_proxy policy method**

In order to customize the Remote Control Proxy in a Non-Standalone environment, it is necessary to modify the `rc_def_proxy` policy method accordingly. This file determines how the Remote Control Proxies usage will be done and how the Controller can connect to the Targets across the firewall.

Example 4-6 shows the settings we used in our `rc_def_proxy` policy method file:

*Example 4-6 The rc\_def\_proxy policy method contents*

---

```
#!/bin/sh
# Default value: NO
echo "YES auto 5020"
exit 0
```

---

When using the Non-Standalone architecture, it is required to provide the following configuration information:

- ▶ Configuration type
- ▶ RC Target Proxy port

In a Non-Standalone scenario, the configuration type *must* always be set to `auto.`, meaning that the Controller will always use the Endpoint Proxy address to reach the RC Target Proxy. The Remote Control Proxy port identifies the port the RC Target Proxy listens for requests from the Controller, which in our scenario is 5020.



The `wgetpolm` and `wputpolm` commands are used to modify the `rc_def_proxy` policy method settings. The procedure is similar to the process shown for the Standalone case study scenario in Example 3-10 on page 107.

### 4.3.3 Remote Control Proxy startup

The process for starting the Remote Control Proxies was described in 3.3.4, “Remote Control Proxy startup” on page 109 and is similar when installed on a Non-Standalone environment. In this section we just provide the content of the `rcproxy.log` file for both the RC Target and Controller Proxies. Since there is a new instance of the Relay exclusive for the Remote Control communications, we also provide the content of the `Relay.log` file. The highlighted lines on the following examples show that the connections between the components separated by a firewall have been established.

Example 4-7 shows the RC Target Proxy log file.

*Example 4-7 The rcproxy.log: RC Target Proxy log file*

---

```
03/02/13 10:49:24 3 2200 logInit - Message logging initialized (level=3,
logmax=1MB).
03/02/13 10:49:25 1 2200 sendCommandLineRequest: cannot connect to
127.0.0.1:3333
03/02/13 10:49:25 0 2200 Proxy label: none (node is root)
03/02/13 10:49:25 0 2200 Proxy type: Target
03/02/13 10:49:25 2 2200 No listen interface specified, defaulting to
INADDY_ANY
03/02/13 10:49:25 0 2200 Proxy listen port: 5020
03/02/13 10:49:25 0 2200 TFST Endpoint Proxy directory: C:\Tivoli\Tivoli
Systems\Tivoli Endpoint Proxy
03/02/13 10:49:25 2 2200 No timeout specified, using default
03/02/13 10:49:25 0 2200 Communication timeout: 240
03/02/13 10:49:25 0 2200 Max sessions: 10
03/02/13 10:49:25 0 2200 Reply to RSM data: no
03/02/13 10:49:25 3 2200 initRoutedSessionsManager: no network card specified
for Children-local-host, using random interface

03/02/13 10:49:25 2 2200 initRoutedSessionsManager: Children-remote-file
parameter not specified
03/02/13 10:49:25 3 2168 routingManager: TELL command received
[1=tic01005-gw]
03/02/13 10:49:25 3 2168 routingManager: WHO reply command received
[1=tic01005-gw]
03/02/13 10:49:25 3 2168 routingManager: TELL command received
[1=tic01005-gw]
```

---

Example 4-8 shows the Relay log file.

*Example 4-8 The Relay.log: Relay log file contents*

---

```
03/02/13 10:52:35 3 844 logInit - Message logging initialized (level=3,
logmax=1MB).
03/02/13 10:52:35 0 844 Relay version 1.3 - level 20020925
03/02/13 10:52:35 0 844 TCP/IP timeout 240
03/02/13 10:52:35 3 844 FSR0001W Relay Started
03/02/13 10:52:35 0 844 Initializing the communication layer ...
03/02/13 10:52:35 3 844 initRoutedSessionsManager: no network card specified
for parent-local-host, using random interface
03/02/13 10:52:35 3 844 initRoutedSessionsManager: no network card specified
for Children-local-host, using random interface

03/02/13 10:52:35 2 844 initRoutedSessionsManager: Children-remote-file
parameter not specified
03/02/13 10:52:36 3 1192 routingManager: TELL command received
[1=tic01005-gw]
03/02/13 10:52:40 3 1920 routingManager: WHO command received
03/02/13 10:52:40 3 1920 routingManager: TELL reply command received
03/02/13 10:52:40 3 1192 routingManager: WHO reply command received
[1=tic01005-gw]
03/02/13 10:52:40 0 844 Communication layer initialized
03/02/13 10:52:40 3 844 Spawn Proxy shutdown monitor thread
03/02/13 10:52:40 3 1920 routingManager: TELL reply command received
```

---

Example 4-9 shows the RC Controller Proxy log file.

*Example 4-9 The rcproxy.log: RC Controller Proxy log file*

---

```
03/02/13 10:44:39 3 1020 logInit - Message logging initialized (level=3,
logmax=1MB).
03/02/13 10:44:41 1 1020 sendCommandLineRequest: cannot connect to
127.0.0.1:3333
03/02/13 10:44:41 0 1020 Proxy label: tic01005-gw
03/02/13 10:44:41 0 1020 Proxy type: controller
03/02/13 10:44:41 2 1020 No timeout specified, using default
03/02/13 10:44:41 0 1020 Communication timeout: 240
03/02/13 10:44:41 0 1020 Max sessions: 10
03/02/13 10:44:41 0 1020 Reply to RSM data: no
03/02/13 10:44:41 3 1020 initRoutedSessionsManager: no network card specified
for parent-local-host, using random interface
03/02/13 10:44:43 3 1032 routingManager: WHO command received [1=null]
03/02/13 10:44:43 3 1032 routingManager: TELL reply command received
```

---

In order to check which ports these Proxies are using to communicate and to verify that no other ports are actually being used, we can use any network status command, such as the **netstat -a** command or similar.

Example 4-10 shows the output of the **netstat -a** command on the RC Target Proxy.

*Example 4-10 The netstat output collected on the RC Target Proxy*

---

Active Connections

Proto	Local Address	Foreign Address	State
TCP	tic010003:1755	tic010003:0	LISTENING
TCP	tic010003:3372	tic010003:0	LISTENING
TCP	tic010003:4000	tic010003:0	LISTENING
TCP	tic010003:4011	tic010003:0	LISTENING
TCP	tic010003:4978	tic010003:0	LISTENING
TCP	tic010003:5020	tic010003:0	LISTENING
TCP	tic010003:6001	tic010003:0	LISTENING
TCP	tic010003:6666	tic010003:0	LISTENING
TCP	tic010003:7007	tic010003:0	LISTENING
TCP	tic010003:7778	tic010003:0	LISTENING
TCP	tic010003:38292	tic010003:0	LISTENING
TCP	tic010003:2334	tic010003:0	LISTENING
TCP	tic010003:3557	tic010003:0	LISTENING
TCP	TIC010003:3557	TIC010003:0	LISTENING
<b>TCP</b>	<b>TIC010003:4000</b>	<b>tic01004:7020</b>	<b>ESTABLISHED</b>
TCP	TIC010003:4011	tic01004:7001	ESTABLISHED
TCP	tic010003:4122	tic010003:0	LISTENING
TCP	tic010003:5020	tic01006:2927	ESTABLISHED
TCP	tic010003:3333	tic010003:0	LISTENING

---

Example 4-11 shows the output of the **netstat -a** command on the Relay.

*Example 4-11 The netstat output collected on the Relay*

---

Active Connections

Proto	Local Address	Foreign Address	State
TCP	tic01004:1025	tic01004:0	LISTENING
TCP	tic01004:1027	tic01004:0	LISTENING
TCP	tic01004:1028	tic01004:0	LISTENING
TCP	tic01004:1033	tic01004:0	LISTENING
TCP	tic01004:1034	tic01004:0	LISTENING
TCP	tic01004:1036	tic01004:0	LISTENING
TCP	tic01004:1040	tic01004:0	LISTENING
TCP	tic01004:1213	tic01004:0	LISTENING
TCP	tic01004:2019	tic01004:0	LISTENING
TCP	tic01004:3372	tic01004:0	LISTENING

TCP	tic01004:4023	tic01004:0	LISTENING
TCP	tic01004:7001	tic01004:0	LISTENING
TCP	tic01004:7020	tic01004:0	LISTENING
TCP	tic01004:8342	tic01004:0	LISTENING
TCP	tic01004:38292	tic01004:0	LISTENING
TCP	tic01004:netbios-ssn	tic01004:0	LISTENING
TCP	tic01004:1056	tic01004:0	LISTENING
TCP	tic01004:4023	tic01005:8020	ESTABLISHED
TCP	tic01004:7001	tic01003:4011	TIME_WAIT
<b>TCP</b>	<b>tic01004:7020</b>	<b>tic01003:4000</b>	<b>ESTABLISHED</b>

---

Example 4-12 shows the output of the `netstat -a` command on the RC Controller Proxy. Notice also that it shows an active connection between the RC Controller Proxy and the Target.

*Example 4-12 The netstat output collected on the Controller Proxy*

---

Active Connections

Proto	Local Address	Foreign Address	State
TCP	tic01005:exec	tic01005:0	LISTENING
TCP	tic01005:1025	tic01005:0	LISTENING
TCP	tic01005:1029	tic01005:0	LISTENING
TCP	tic01005:1034	tic01005:0	LISTENING
TCP	tic01005:1044	tic01005:0	LISTENING
TCP	tic01005:2598	tic01005:0	LISTENING
TCP	tic01005:3372	tic01005:0	LISTENING
TCP	tic01005:7018	tic01005:0	LISTENING
TCP	tic01005:8001	tic01005:0	LISTENING
TCP	tic01005:8020	tic01005:0	LISTENING
TCP	tic01005:9494	tic01005:0	LISTENING
TCP	tic01005:38292	tic01005:0	LISTENING
TCP	tic01005:1428	tic01005:0	LISTENING
<b>TCP</b>	<b>tic01005:2598</b>	<b>tic01007:2501</b>	<b>ESTABLISHED</b>
TCP	tic01005:6947	tic01007:9495	TIME_WAIT
TCP	tic01005:6948	tic01007:9495	TIME_WAIT
TCP	tic01005:8001	tic01004:4021	ESTABLISHED
<b>TCP</b>	<b>tic01005:8020</b>	<b>tic01004:4023</b>	<b>ESTABLISHED</b>
TCP	tic01005:3333	tic01005:0	LISTENING

---

The highlighted lines in the foregoing examples show the connection between the RC Proxies and Relay components.

Also notice that both netstat outputs were collected *before* any remote control session was actually started.

Example 4-13 lists the output of the **rcproxy** command that shows the active connection.

*Example 4-13 The output of the rcproxy -list command*

---

```
id=1, Target=tic01007, proxy_label=n/a  
total sessions = 1
```

---





## Part 3

# Troubleshooting







## Troubleshooting techniques

IBM Tivoli Remote Control 3.8 aims to establish remote control session across firewalls using the Remote Control Proxy technology. While the systems administrator can perform many tasks relatively easy, the code Tivoli provides to achieve those tasks is extraordinarily complex. With the solid foundation of the Tivoli Management Framework, this complexity can remain largely masked from the administrator. However, with such a sophisticated set of products, there will be occasions when those designing, testing, and implementing Tivoli solutions will encounter situations that are not resolved by reference to product manuals alone.

In problem-solving situations, you need to understand what is going on between the product components, what messages and trace output means, and what extra actions you can take to try to resolve a problem.

The following troubleshooting topics are discussed in this chapter:

- ▶ Generic problem determination outline
  - Session startup with emphasis on Framework, Tivoli Firewall Security Toolbox, and RC Proxies problem determination processes
  - Session management
  - Standalone environment
- ▶ Troubleshooting Remote Control Proxies examples
- ▶ Troubleshooting firewall information

## 5.1 Generic problem determination outline

To obtain an overall picture of what is happening on the IBM Tivoli Remote Control side when a session is established through a firewall, there are several troubleshooting steps to follow and logs that need to be analyzed.

You could face problems during:

- ▶ Session startup
- ▶ Session management

In order to help you isolate problems you experience with the Remote Control Proxies, we provide general troubleshooting guidelines and processes that may offer you a way to organize your problem determination strategy.

### 5.1.1 Session startup

As soon as the Remote Control Tool is started, the `pcremote` process is triggered. It performs several checks before starting the session and connecting the RC Controller to the RC Target machine. All the steps performed by the `pcremote` process are tracked in the `pcremote` trace file.

This troubleshooting section does not describe the `pcremote` traces analysis, since the objective here is to only debate the proxy's components. Anyway, by providing general troubleshooting ideas for other items, like the IBM Tivoli Management Framework, Tivoli Firewall Security Toolbox (TFST), and the RC Proxies, this can help you to understand the whole picture of the modules dependencies.

Next, you will find the complete process that is used to determine if there is a problem with the Remote Control Proxies. As IBM Tivoli Remote Control 3.8 has been designed to work with both IBM Tivoli Management Framework and the TSFT, IBM Tivoli Remote Control's functionality is highly dependent on those components. Thus, before analyzing any Remote Control logs or trace files, you need to be sure that any of the IBM Tivoli Management Framework and TFST components are working properly.

The following sections show a series of flows that represent the fundamental steps you need to perform for troubleshooting issues when establishing Remote Control sessions through the firewall, from the time you click the **Run** button of the Remote Control Tool, to the time the session between the RC Controller and the RC Target is established.

## Endpoint problem determination process

Before starting the problem determination, we recommend that you follow these steps in order to have a clear picture of what is going wrong:

1. Set the `lcmd` debug level to 3 on the Endpoint by editing the `last.cfg` file and by changing the `log_threshold` parameter to 3. You need to restart the service.
2. Set the Gateway level to 7 by entering the following commands:

```
wgateway [Gateway label] set_debug_level 7  
wgateway [Gateway label] restart
```

Figure 5-1 defines the most common steps used to isolate Endpoint connection problems. These checks must be made first, because if the Endpoint faces connection problems, the Remote Control session will never start at all.

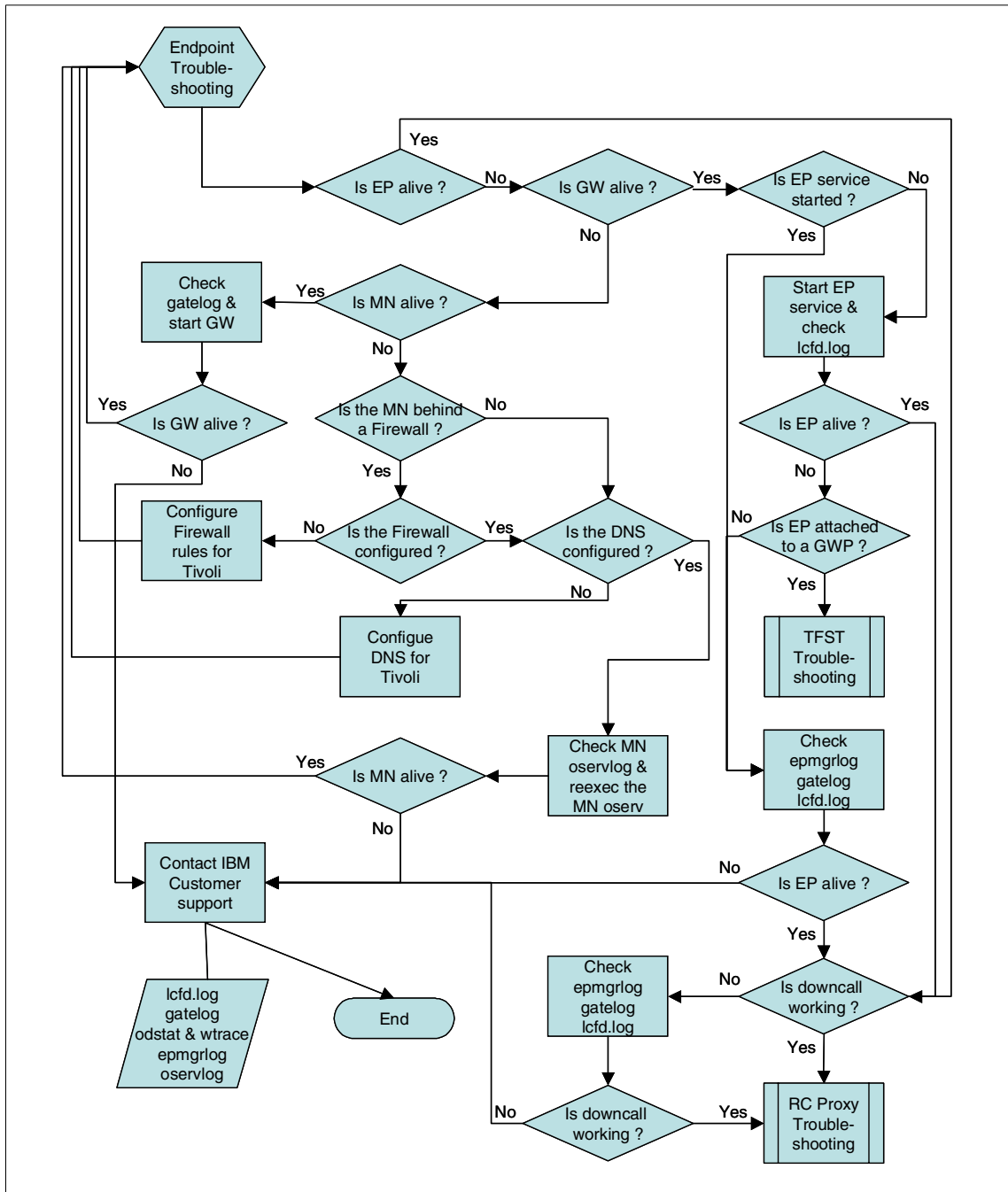

Figure 5-1 Endpoint problem determination flow

From here on, the Endpoint problem determination process is explained in detail. However, for more detailed information regarding Endpoint troubleshooting, refer to the *Tivoli Management Framework Maintenance and Troubleshooting Guide*, GC32-0807.

► Is Endpoint alive?

The Endpoint must be alive in order to let the pcremote process send it the necessary down calls. The following command could be used:

```
wep [Endpoint label] status
```

► Is Gateway alive?

If the Endpoint is not alive, the problem could be issued by the Gateway unavailability. The command that can be used to control the Gateway is:

```
wgateway [Gateway label]
```

► Is the EP service started?

If an Endpoint is not alive and its Gateway is up, you have to control if the Endpoint service is started locally on the machine.

If the service is not started, you have to start it. However, in the case of the service fails to start, you could check the `lcf.d.log` to analyze why the service is failing to start.

If the Endpoint service is started and the Endpoint is still not alive, the `epmgrlog`, located on the TMR Server, the `gatelog`, located on the Endpoint Gateway and the `lcf.d.log`, located on the local machine could you help to isolate the problems.

► Is Endpoint attached to a Gateway Proxy?

If either the RC Controller or the RC Target is connected to a Gateway Proxy, you must be sure that your TFST environment is correctly configured and is working. However, before starting this complex process, first you must be sure that you have made the minimum control on the Endpoint, to verify that the Endpoint itself is not causing the issue. Next, in order to help you follow the necessary steps to determine if your TFST environment is working, we have defined a specific process. Refer to “TFST problem determination process” on page 147 for more information.

► Is downcall working?

Even if the Endpoint is alive, it could be impossible for the Framework to issue down calls on the Endpoint. You could check if the spawning of Framework methods work properly by executing the following command:

```
wadminep [Endpoint label] view_version
```

If you get the version of the Endpoint, this means the downcall is working. Otherwise, you could face some local Endpoint security restrictions. To isolate the problem, you could refer to the `epmgrlog`, located on the TMR Server, the `gatelog`, located on the Endpoint Gateway, and the `lcfid.log`, located on the local machine, which could provide you with much information regarding the Endpoint communication.

► Is the Managed Node alive?

If one of the Gateways is not alive, the Managed Node, which hosts the Gateway, could be down itself. The command to check the availability of the Managed Node is:

```
wping [Managed Node hostname]
```

If the Managed Node is up and the Gateway is not, you could check the `gatelog` located on the Managed Node and try to restart the Gateway using the `wgateway` command.

► Is the Managed Node behind a firewall?

In a Standalone Remote Control Proxy environment, one Managed Node is located behind a firewall, and communication problems could result from this configuration.

► Is the firewall configured?

If the Managed Node is behind a firewall, some ports are defined at the Framework level to fix the Tivoli communications. Rules need to be created on the firewall to allow this type of communication.

► Is the DNS configured?

Tivoli is really dependent of the Domain Name Server (DNS) configuration. If the normal and reserve hostname resolution are not working either from the TMR Server to the Managed Node, or from the Managed Node to the TMR server, the Framework will never be able to establish communications between its different components.

However, if the DNS is correctly configured and the Managed node is still not alive, you could analyze the local Managed Node `oservlog` and/or reexec the Managed Node.

Nevertheless, if the various problems could not be isolated even after you have executed all actions and analyzed all of the logs mentioned above, it is advised that you contact IBM customer support and provide them the following logs:

- `lcfid.log` — located on the local machine
- `gatelog` — located on the Endpoint Gateway
- `epmgrlog` — located on the TMR Server
- `oservlog` — located on the TMR Server and on the Endpoint Gateway

- ▶ The **odstat** and **wtrace** command outputs (for more information on how to get a Framework trace, refer to the *Tivoli Management Framework Maintenance and Troubleshooting Guide*, GC32-0807).

Conversely, if every communication is working fine between the different components of the Framework, the problem could be located at the Remote Control Proxy level. To help you follow the necessary steps to determine if your RC Proxy environment is working, we have defined a specific process. Refer to “RC Proxy problem determination process” on page 151 for more information.

## TFST problem determination process

Before starting the problem determination, we recommend that you follow these steps in order to have a clear picture of what is going wrong:

1. Back up and rename the `epp.log` file on Endpoint Proxy, the `gwp.log` on the Gateway Proxy and the `relay.log` on the Relay. New `epp.log`, `gwp.log`, and `relay.log` files are created by default as soon as the services are started.
2. Edit the `gwp.cfg` file on the Gateway Proxy, change the `debug-level` entry to **8** as explained in the *Firewall Security Toolbox User's Guide*, GC23-4826, and restart the service.
3. Edit the `epp.cfg` file on the Endpoint Proxy, change the `debug-level` entry to **8** as explained in the *Firewall Security Toolbox User's Guide*, GC23-4826, and restart the service.
4. Edit the `relay.cfg` file on the Relay, if used in your environment, change the `debug-level` entry to **8** as explained in the *Firewall Security Toolbox User's Guide*, GC23-4826, and restart the service.
5. Set the `lcmd` debug level to **3** on the Endpoint by editing the `last.cfg` file on the Endpoint and by changing the `log_threshold` parameter to 3. You need to restart the service.
6. Set the Gateway level to **7** by entering the following commands:

```
wgateway [Gateway label] set_debug_level 7  
wgateway [Gateway label] restart
```

Figure 5-2 defines the most common steps used to isolate the TFST connection problems. These checks must be made only if the Remote Control Proxy is installed on top of a TFST environment. If the Endpoint faces connection problems with its Gateway Proxy, or if the Gateway Proxy is not able to communicate with its Endpoint Proxy, the Remote Control session will never start at all.

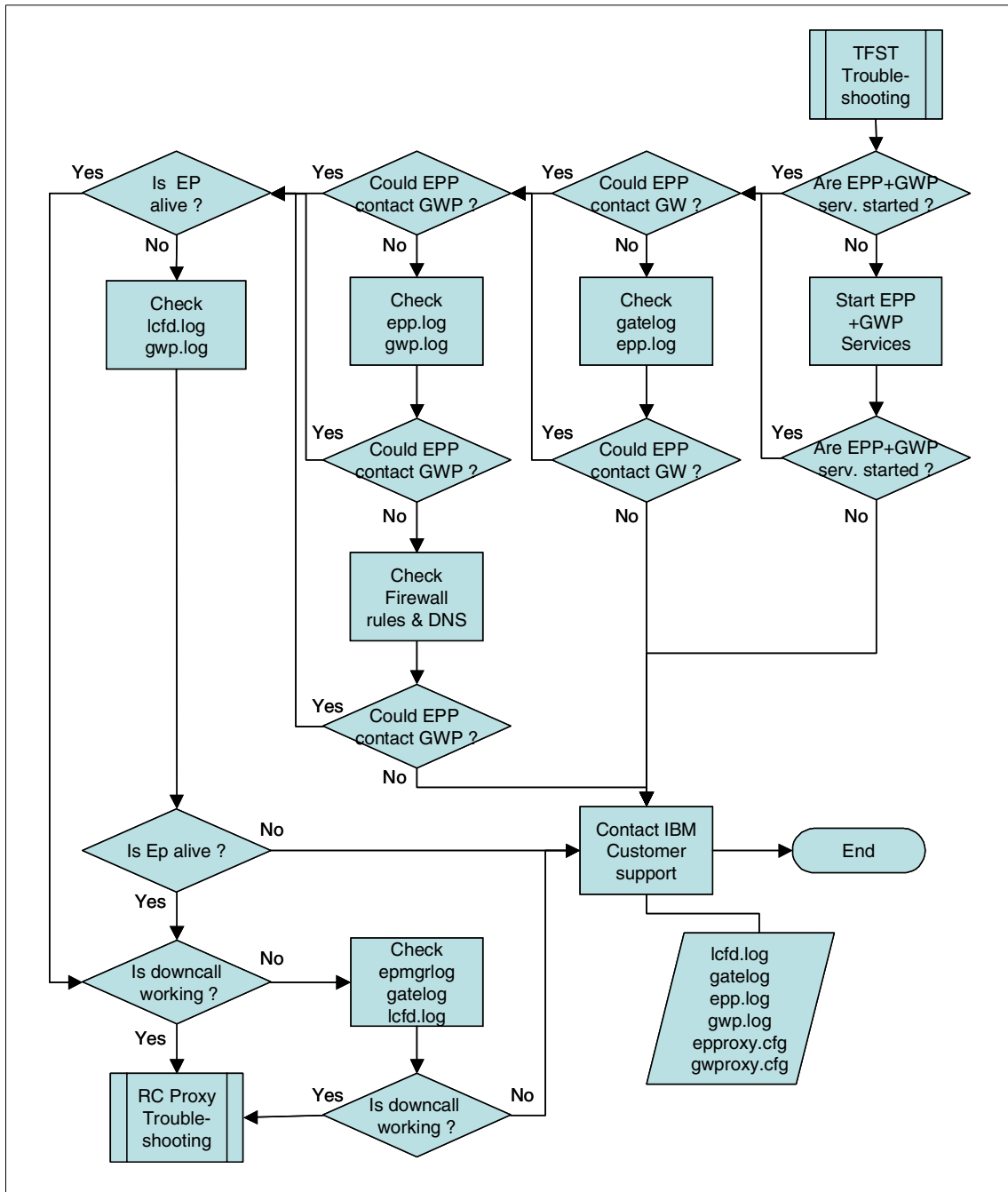

Figure 5-2 TFST problem determination flow



From here on, the TFST problem determination process is explained in detail. However, for more detailed information regarding the TFST troubleshooting refer to the Firewall Security Toolbox User's Guide, GC23-4826.

- ▶ Are Endpoint Proxy and Gateway Proxy services started?

If these services or process are not up and running, you need to start them. If you are using a relay between the two proxies, you need to verify that the Relay service or process is up and running too.

- ▶ Could the Endpoint Proxy contact the Gateway?

Ensure that the Endpoint Proxy is configured to communicate with the correct Gateway (address and port). When the Endpoint Proxy process starts, it logs in the epp.log a message stating the gateway IP and port with which it will communicate.

If the Gateway information found in the log is not correct, you could review it by changing the Gateway Host keyword value of the [Endpoint Proxy] section in the epproxy.cfg file.

- ▶ Could the Endpoint Proxy contact the Gateway Proxy?

When the components are started, they try to exchange signals, called a handshake. The Endpoint Proxy sends to its Gateway Proxy a Who request and then the Gateway Proxy replies. Similarly, the Gateway Proxy sends to its Endpoint Proxy a Tell message and the Endpoint Proxy replies.

These exchanges enable the components in a chain of communication to establish the labels of all the components in the chain. When one of the components is not running, the handshake fails. A message in the epp.log and in the gwp.log file list the component with which the handshake failed.

If you also use a relay, you need to look at the relay.log too to control if the handshake is made between the Endpoint Proxy and the Relay but also between the Relay and the Gateway Proxy.

Furthermore, you have to be sure that the Endpoint Proxy is trying to communicate with the Gateway Proxy, and inversely, using the correct IP address and ports. Check the epproxy.cfg, gwproxy.cfg and the relay.cfg, if a Relay is used, files to control which IP address and ports are configured.

If communication problems occur, check that the ports used by the Proxies are not already used by other applications. Check also that the firewall is not preventing any communication and that the DNS is configured to correctly resolved, normal and reverse resolution, the Tivoli hostnames.

► Is Endpoint alive?

The Endpoint must be alive in order to let the pcremote process send it the necessary down calls. The following command could be used:

```
wep [Endpoint label] status
```

If the Endpoint is not alive, you have to control if the Endpoint is able to communicate with its Gateway Proxy. Check the lcfid.log and the gwp.log to control if the Endpoint is using the correct IP address and port to communicate with its Gateway Proxy.

► Is downcall working?

Even if the Endpoint is alive, it could be impossible for the Framework to issue down calls on the Endpoint. You could check if the spawning of Framework methods work properly by executing the following command:

```
wadminep [Endpoint label] view_version
```

If you get the version of the Endpoint, this means the downcall is working. Otherwise, you could face some local Endpoint security restrictions. To isolate the problem, you could refer to the epmgrlog, located on the TMR Server, the gatelog, located on the Endpoint Gateway and the lcfid.log, located on the local machine which could provide you a lot of information regarding the Endpoint communication.

Nevertheless, if the different problems could not be isolated even after you have executed all actions and analyzed all of the logs mentioned above, it is advised that you contact the IBM customer support by providing them the following logs:

- lcfid.log — located on the local machine
- gatelog — located on the Endpoint Gateway
- epp.log and epproxy.cfg — located on the Endpoint Proxy
- gwp.log and gwproxy.cfg — located on the Gateway Proxy
- relay.log and relay.cfg — located on the Relay, if used in your environment

Conversely, if every communication is working fine between the different components of the TFST, the problem could be located at the Remote Control Proxy level. To help you follow the necessary steps to determine if your RC Proxy environment is working, we have defined a specific process that will be covered in the next section.

## RC Proxy problem determination process

Before starting the problem determination, we recommend that you follow these steps in order to have a clear picture of what is going wrong:

1. Edit the `remcon.ini` file on the RC Controller and RC Target, set `trace_level` parameter to 3 in the Generic section as explained in the *IBM Tivoli Remote Control User's Guide*, SC23-4842 and restart the service.
2. Edit the `relay.cfg` file on the Relay, if used in your environment, change the debug-level entry to 8 as explained in the *Firewall Security Toolbox User's Guide*, GC23-4826 and restart the service.
3. Set the `lcf` debug level to 3 on the Endpoint by editing the `last.cfg` file on the Endpoint and by changing the `log_threshold` parameter to 3. You need to restart the service.
4. Back up and rename the `rcproxy.log` file both on RC Target Proxy and RC Controller Proxy. A new `rcproxy.log` file is created by default as soon as the RC Proxy service is started
5. Back up and rename the `remcon.log` and `remcon.trc` files on the RC Controller and on the RC Target.

Figure 5-3 on page 152 defines the most common steps used to isolate the RC Proxy connection problems. These checks must be made only after controlling if the Framework and TFST communication are correctly configured and that the Endpoint is alive and ready to accept all necessary Remote Control down calls.

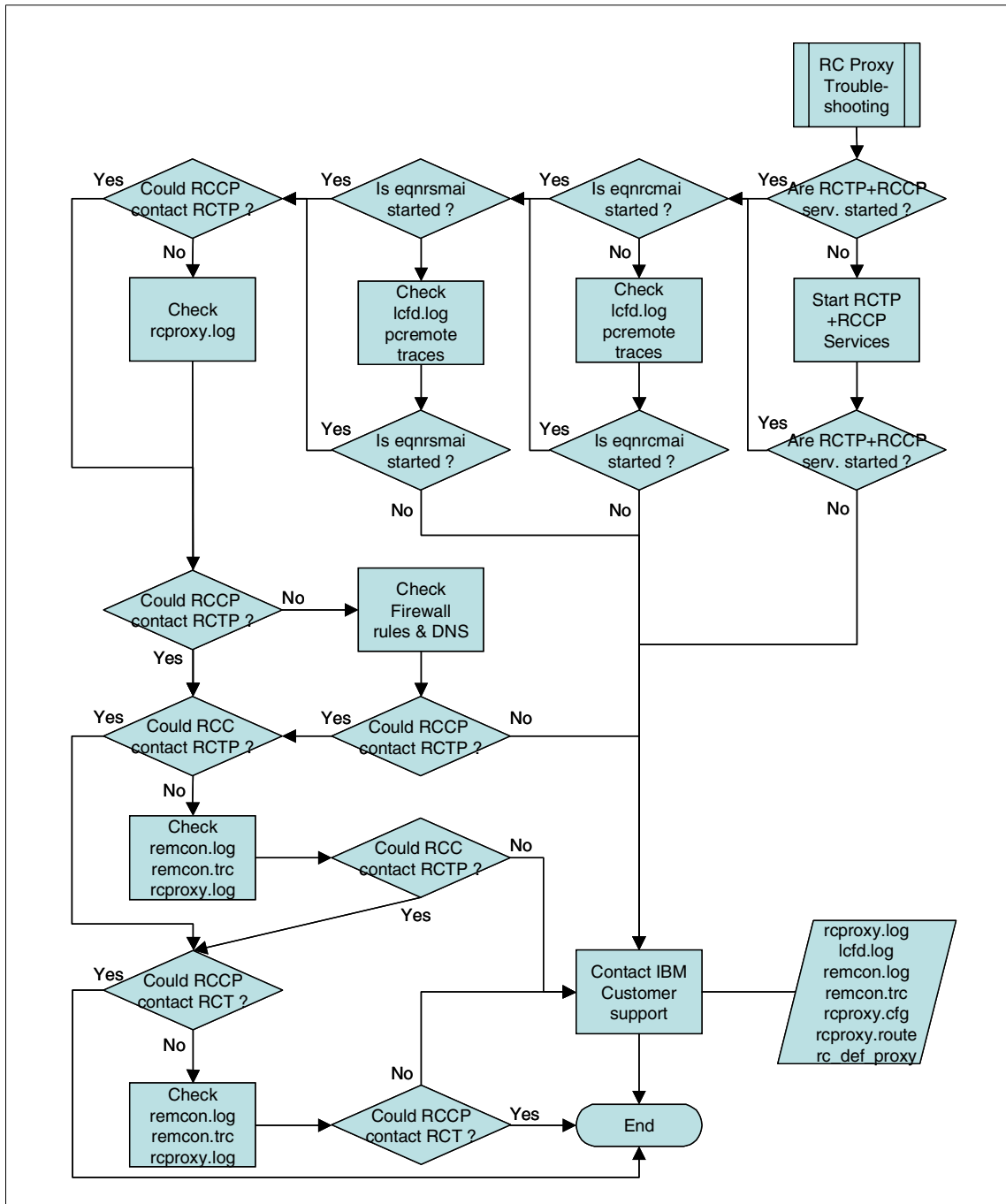

Figure 5-3 RC Proxy problem determination flow

From here on, the RC Proxy problem determination process is explained in detail.

- ▶ Are RC Target Proxy and RC Controller Proxy services started?

If these services or process are not up and running, you need to start them. If you are using a Relay between the two proxies, you need to verify that the Relay service or process is up and running too.

- ▶ Could the RC Target Proxy contact the RC Controller Proxy?

When the components are started, they try to exchange signals, called a handshake. The Parent RC Proxy sends to its Child Proxy a Who request and then the Child Proxy replies. Similarly, the Child RC Proxy sends to its Parent RC Proxy a Tell reply message and the Parent RC Proxy replies.

These exchanges enable the components in a chain of communication to establish the labels of all the components in the chain. When one of the components is not running, the handshake fails. A message in the rcproxy.log on the Parent and Child RC Proxy list the component with which the handshake failed.

You can refer to the section 5.2.1, “The rcproxy.log file” on page 155, to know how to check this information in the rcproxy.log file.

If you also use a relay, you need to look at the relay.log too to control if the handshake is made between the Parent RC Proxy and the Relay but also between the Relay and the Child RC Proxy.

Furthermore, you have to be sure that the Parent RC Proxy is trying to communicate with the Child RC Proxy, and inversely, using the correct IP address and ports. Check the rcproxy.cfg of the RC Target Proxy and RC Controller Proxy and the relay.cfg, if a Relay is used, files to control which IP address and ports are configured.

If communication problems occur, check that the ports used by the RC Proxies are not already used by other applications. Check also that the firewall is not preventing any communication and that the DNS is configured to correctly resolved, normal and reverse resolution, the Tivoli hostnames.

- ▶ Is eqnrcmai process started on RC Target?

You need to verify if the **eqnrcmai.exe** process is spawned on the RC Target. This can be verified by either checking the lcfid.log file or by using a process monitor tool, such as the Windows Task Manager. It maybe possible that this process is already running when you are starting the session, and since it cannot be started twice, you need to kill it or wait 5-10 minutes so that it is automatically killed before attempting a new session.

- ▶ Is the `eqnrsmmai` process started on the RC Controller?

If the `eqnrcmai.exe` is spawned at RC Target, you also need to verify if the `eqnrsmmai.exe` process has been spawned on the RC Controller. This can be verified by either checking the `lcf.d.log` file or by using a process monitor tool, such as Windows Task Manager.

- ▶ Could the RC Controller contact the RC Target Proxy?

As soon as the `eqnrcmai.exe` is spawned at the RC Controller, the RC Controller tries to contact the RC Target Proxy using the IP address and port defined in the `rc_def_proxy` RC Policy. The same port must also be configured in the `proxy-port` parameter of the `[rcproxy]` section in the `rcproxy.cfg` file on the RC Target Proxy.

To control which port is used by each component, check the `remcon.log`, `remcon.trc` and the `rcproxy.log`.

- ▶ Could the RC Controller Proxy contact the RC Target?

Once the RC Target Proxy received the session request from the RC Controller, it has to forward it to the RC Controller Proxy who needs, in its turn, to contact the RC Target. The RC Controller is able to find the RC Target based on the information provided by the RC Target Proxy, either from Endpoint Database of the Endpoint Proxy in a TFST environment or from the `rcproxy.route` file of the RC Target Proxy in a Standalone environment.

To control if the RC Controller Proxy is trying to contact the RC Target using the correct IP Address, check the `remcon.log`, `remcon.trc` and the `rcproxy.log`. If the RC Controller Proxy doesn't use the correct information, check the `rcproxy.route` file on the RC Target Proxy or control if the Endpoint Database of the Endpoint Proxy is not corrupted or contain the correct information.

Nevertheless, if the different problems could not be isolated even after you have executed all actions and analyzed all of the logs mentioned above, it is advised that you contact the IBM customer support by providing them the following logs:

- ▶ `lcf.d.log` — located on the local machine
- ▶ `rcproxy.log` — located on the RC Target Proxy and RC Controller Proxy
- ▶ `remcon.trc` — located on the RC Controller and RC Target
- ▶ `remcon.log` — located on the RC Target and RC Controller
- ▶ `rcproxy.cfg` located on the RC Target Proxy and on the RC Controller Proxy
- ▶ `rc_def_proxy` Default Remote Control Policy method
- ▶ `rcproxy.route` — located on the RC Target Proxy, in a Standalone environment
- ▶ `relay.log` and `relay.cfg` — located on the Relay, if used in your environment

## 5.1.2 Session management

If you experience problems once the session have been successfully established, you need to collect the related RC Controller and RC Target trace files according to the *IBM Tivoli Remote Control User's Guide*, SC23-4842. It is recommended to check also the RC Target Proxy and RC Controller Proxy status in order to verify that the Proxy process isn't crashed or it has not been stopped after establishing the session.

## 5.2 Troubleshooting the Remote Control Proxy

In this section we focus on the IBM Tivoli Remote Control log files. As mentioned in the 5.1, "Generic problem determination outline" on page 142, there are a few logs and trace files we need to look at to troubleshoot the Remote Control Proxy component when starting session across firewalls:

<b>rcproxy.log</b>	Remote Control Target and Controller Proxy log file
<b>remcon.trc</b>	Remote Control Controller generic information trace file

### 5.2.1 The rcproxy.log file

The rcproxy.log file is created at Remote Control Proxy service startup. Both RC Target and Controller Proxies have their own rcproxy.log file. By default, this log file is stored in the Remote Control Proxy installation directory.

The rcproxy.log default settings can be modified editing the rcproxy.cfg file. Example 5-1 shows the log section and the related parameters we can change to create the rcproxy.log file.

*Example 5-1 The rcproxy.log file settings in the rcproxy.cfg file*

---

```
[log]
log-file=rcproxy.log
debug-level=3
max-size=1
[rcproxy]
epp-directory=C:\Tivoli\Tivoli Systems\Tivoli Endpoint Proxy
proxy-port=5020
proxy-type=target
cmdline-port=3333
[communication-layer]
children-local-port=6020
children-remote-list=tic01004+7020
children-cm-type=cm-tcp-unidirectional
buffer-size=1024
[children-cm-info]
connection-mode=client
```

---

By default, the rcproxy.log file has debug level 3, the one we recommend, since it will display comprehensible information. But this parameter can have values between 0-11. Since values higher than 3 contain debugging information used by developers also, we recommend that you set them only if requested by the Customer Support Engineers, since this will notably affect the performance of the Remote Control Proxy service, and because the error messages may not be easily understood.

When the Remote Control Proxy service starts, it loads all the information stored in the rcproxy.cfg. The Proxy service startup and the connection between proxies information are then stored in the rcproxy.log file

Example 5-2 shows the rcproxy.log file contents.

*Example 5-2 The Target Proxy log file*

---

```
03/02/06 15:59:00 3 2104 logInit - Message logging initialized (level=3,
logmax=1MB).
03/02/06 15:59:01 1 2104 sendCommandLineRequest: cannot connect to
127.0.0.1:3333
03/02/06 15:59:01 0 2104 Proxy label: none (node is root)
03/02/06 15:59:01 0 2104 Proxy type: target
03/02/06 15:59:01 2 2104 No listen interface specified, defaulting to
INADDY_ANY
03/02/06 15:59:01 0 2104 Proxy listen port: 5020
03/02/06 15:59:01 0 2104 TFST Endpoint Proxy directory: C:\Tivoli\Tivoli
Systems\Tivoli Endpoint Proxy
03/02/06 15:59:01 2 2104 No timeout specified, using default
03/02/06 15:59:01 0 2104 Communication timeout: 240
03/02/06 15:59:01 0 2104 Max sessions: 10
03/02/06 15:59:01 0 2104 Reply to RSM data: no
03/02/06 15:59:01 3 2104 initRoutedSessionsManager: no network card specified
for children-local-host, using random interface

03/02/06 15:59:01 2 2104 initRoutedSessionsManager: children-remote-file
parameter not specified
03/02/06 15:59:02 3 1344 routingManager: WHO reply command received
[1=tic01005-gw]
03/02/06 16:00:55 3 1344 routingManager: TELL command received
[1=tic01005-gw]
```

---

The structure of the messages is explained as follows:

<date> <time> <debug-level> <thread> <message>

For example:

03/02/06 15:59:01 0 2104 Proxy listen port: 5020, where:



```
<debug-level> = 0
<thread> = 2104
<message> = Proxy listen port: 5020
```

From the log, we are able to gather information regarding the Proxy name and type, if it is a Child or a Parent, if it is running on a TFST environment and, above all, if the connection with the other Proxies is working. Analyzing the log information showed in Example 5-2, we see that:

- ▶ This is a Target Proxy.  
03/02/06 15:59:01 0 2104 Proxy type: target
- ▶ It runs on the Endpoint Proxy machine and therefore it is a Parent Proxy.  
03/02/06 15:59:01 0 2104 Proxy label: none (node is root)  
  
03/02/06 15:59:01 0 2104 TFST Endpoint Proxy directory:  
C:\Tivoli\TivoliSystems\Tivoli Endpoint Proxy
- ▶ The Proxy listen port is 5020, this is the port used by the Controller to communicate with the Target Proxy.  
03/02/06 15:59:01 0 2104 Proxy listen port: 5020
- ▶ The Target Proxy is communicating with the Controller Proxy tic01005-gw.  
03/02/06 15:59:02 3 1344 routingManager: WHO reply command received  
[l=tic01005-gw]  
03/02/06 16:00:55 3 1344 routingManager: TELL command received  
[l=tic01005-gw]

This rcproxy.log file refers to the Target Proxy log file.

A typical example of the Controller Proxy log file is shown in Example 5-3.

*Example 5-3 The Controller Proxy log file*

---

```
03/02/04 15:53:37 1 1000 sendCommandLineRequest: cannot connect to
127.0.0.1:3333
03/02/04 15:53:37 0 1000 Proxy label: tic01005-gw
03/02/04 15:53:37 0 1000 Proxy type: controller
03/02/04 15:53:37 2 1000 No timeout specified, using default
03/02/04 15:53:37 0 1000 Communication timeout: 240
03/02/04 15:53:37 0 1000 Max sessions: 10
03/02/04 15:53:37 0 1000 Reply to RSM data: no
03/02/04 15:53:37 3 1000 initRoutedSessionsManager: no network card specified
for parent-local-host, using random interface
03/02/04 15:53:39 3 892 routingManager: WHO command received [l=null]
03/02/04 15:53:39 3 892 routingManager: TELL reply command received
```

---

The message structure is the same as we have in the Target Proxy log file.

From this log we are able to gather information regarding the Proxy name, Proxy type, the number of sessions that this Proxy can handle at the same time, and the communication status.

The last few lines of the rcproxy.log, marked in bold, show that the communication between Controller and Target Proxy is working.

## 5.2.2 The remcon.trc

This is a generic trace file used to log information related to the Remote Control Controller or Target machine.

On Windows platforms, for example, you can enable the logging of remote control events or errors that occur during a session by setting the keywords of the GENERIC section in the <Windows\_installation\_directory>\remcon.ini file of the Controller and Target workstation.

By default, the debug level of this file is set to 0 (disabled), but this can be changed to different values. For more information on this matter, you can refer to the *IBM Tivoli Remote Control User's Guide, SC23-4842*.

In this section we analyze the Controller trace file only, since the objective is to verify if the Controller is connecting to the Target Proxy.

### Controller trace file

The remcon.trc could be useful when the proxies communication is working but we are still not able to attempt a remote control session through the firewall. The problem, in this case, could be in the Controller area. It could be possible that the Controller is not able to connect to the Target Proxy.

Example 5-4 shows the remcon.trc file of Controller machine. From this file, we need to look at the following parameter settings:

- /C Identifies the Target Proxy port (rc\_def\_proxy policy method)
- /B Identifies the Endpoint object dispatcher number
- /D Identifies the Gateway Proxy this Endpoint belongs to (if any is specified)

Verify they are the correct ones, comparing them with the rc\_def\_proxy policy method and rcproxy.log (Target Proxy):

*Example 5-4 The remcon.trc file for the Controller machine*

---

```
[2808] Thu Feb 06 17:10:45 2003 3 found /C parameter
[2808] Thu Feb 06 17:10:45 2003 3 Proxy port is: [5020]
[2808] Thu Feb 06 17:10:45 2003 3 found /E parameter
[2808] Thu Feb 06 17:10:45 2003 3 found /B parameter
```

```

[2808] Thu Feb 06 17:10:45 2003 3 EP odnum is 12
[2808] Thu Feb 06 17:10:45 2003 3 CMainFrame::OnCreate - Creating status bar
[2808] Thu Feb 06 17:10:45 2003 3 CMainFrame::OnCreate - Creating resizable
toolbar
[2808] Thu Feb 06 17:10:45 2003 3 Connection with proxy
[2808] Thu Feb 06 17:10:45 2003 3 Connection port is: [5020]
[2808] Thu Feb 06 17:10:45 2003 3 Connection was opened
[2808] Thu Feb 06 17:10:45 2003 3 GetSIDofCurrentUser - Entering...
[2808] Thu Feb 06 17:10:45 2003 3 GetSIDofCurrentUser - OS version query
successful
[2808] Thu Feb 06 17:10:45 2003 3 GetSIDofCurrentUser - Query on Winlogon
registry branch successful, returned Administrator
[2808] Thu Feb 06 17:10:45 2003 3 GetSIDofCurrentUser - szMachineName retrieval
successful, returned TIC01006
[2808] Thu Feb 06 17:10:45 2003 3 GetSIDofCurrentUser - szFullUserName is
TIC01006\Administrator
[2808] Thu Feb 06 17:10:45 2003 3 GetSIDofCurrentUser - LookupAccountName
successful, Binary SID for this user retrieved
[2808] Thu Feb 06 17:10:45 2003 3 GetSIDofCurrentUser - Binary SID is valid
[2808] Thu Feb 06 17:10:45 2003 3 GetSIDofCurrentUser - Going to return the SID
for the current user: S-1-5-21-1417001333-76473
3703-1343024091-1010
[2808] Thu Feb 06 17:10:45 2003 3 ProxyData : ep_label TIC01007
[2808] Thu Feb 06 17:10:45 2003 3 ProxyData : ep_address 9.3.5.29
[2808] Thu Feb 06 17:10:45 2003 3 ProxyData : ep_port 2501
[2808] Thu Feb 06 17:10:45 2003 3 ProxyData : ep_is_proxied 1
[2808] Thu Feb 06 17:10:45 2003 3 ProxyData : proxy_port 5020
[2592] Thu Feb 06 17:13:05 2003 3 found /C parameter
[2592] Thu Feb 06 17:13:05 2003 3 Proxy port is: [5020]
[2592] Thu Feb 06 17:13:05 2003 3 found /E parameter
[2592] Thu Feb 06 17:13:05 2003 3 found /B parameter
[2592] Thu Feb 06 17:13:05 2003 3 EP odnum is 12
[2592] Thu Feb 06 17:13:05 2003 3 CMainFrame::OnCreate - Creating status bar
[2592] Thu Feb 06 17:13:05 2003 3 CMainFrame::OnCreate - Creating resizable
toolbar
[2592] Thu Feb 06 17:13:05 2003 3 Connection with proxy
[2592] Thu Feb 06 17:13:05 2003 3 Connection port is: [5020]
[2592] Thu Feb 06 17:13:05 2003 3 Connection was opened

```

---

In our specific example we don't have the /D parameter; this because in our testing scenario the Controller is not connected to a Gateway Proxy.

The Controller trace file is useful if its contents are analyzed together with the rproxy.log (or rproxy.cfg) of the Target Proxy machine. In this way we are able to verify if the Controller is connecting to the right Proxy using the right port. An example is provided in 5.3.1, "Case 1: Controller not connecting to Target Proxy" on page 160.

## 5.3 Troubleshooting examples

In this section we provide a few troubleshooting examples for Remote Control session startup problems in a TFST environment, using the testing scenario in Figure 4-2.

### 5.3.1 Case 1: Controller not connecting to Target Proxy

In this case we describe a troubleshooting example of a startup session problem when the Proxy configuration is not correct. Specifically, the Proxy port specified in the Target Proxy configuration files does not match with the Proxy port specified in the `rc_def_proxy` policy method, and the Controller is not able to connect to the Target Proxy.

As soon as we start the session, the message box shown in Figure 5-4 is displayed on the Controller.

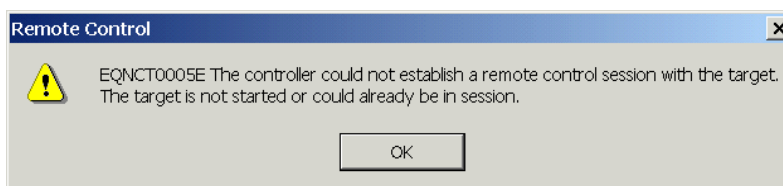

Figure 5-4 Error message displayed on Controller when attempt a session

From this point we start the problem determination, following step-by-step the diagrams reported in 5.1, “Generic problem determination outline” on page 142.

1. Check that both Target and Controller Endpoint are alive and that the Framework down call works against these Endpoints.

Check the Controller Endpoint:

```
wep tic01006 status  
tic01006 is alive
```

Check the Target Endpoint:

```
wep tic01007 status  
tic01007 is alive
```

2. We assume that the Endpoint Proxy, Relay, and Gateway Proxy services and their communication are working.
3. We assume that both Target and Controller Proxy services are up and running.
4. We check the Target and Controller Proxy communication by looking at the Proxy log files.

For this purpose we look at the WHO-TELL message in the Target (Example 5-5) and Controller (Example 5-6) rcproxy.log.

*Example 5-5 The Target Proxy log file*

---

```
03/02/12 11:39:22 3 1340 logInit - Message logging initialized (level=3,
logmax=1MB).
03/02/12 11:39:23 1 1340 sendCommandLineRequest: cannot connect to
127.0.0.1:3333
03/02/12 11:39:23 0 1340 Proxy label: none (node is root)
03/02/12 11:39:23 0 1340 Proxy type: target
03/02/12 11:39:23 2 1340 No listen interface specified, defaulting to
INADDY_ANY
03/02/12 11:39:23 0 1340 Proxy listen port: 5020
03/02/12 11:39:23 0 1340 TFST Endpoint Proxy directory: C:\Tivoli\Tivoli
Systems\Tivoli Endpoint Proxy
03/02/12 11:39:23 2 1340 No timeout specified, using default
03/02/12 11:39:23 0 1340 Communication timeout: 240
03/02/12 11:39:23 0 1340 Max sessions: 10
03/02/12 11:39:23 0 1340 Reply to RSM data: no
03/02/12 11:39:23 3 1340 initRoutedSessionsManager: no network card specified
for children-local-host, using random interface

03/02/12 11:39:23 2 1340 initRoutedSessionsManager: children-remote-file
parameter not specified
03/02/12 11:39:23 3 2104 routingManager: TELL command received
[1=tic01005-gw]
03/02/12 11:39:24 3 2104 routingManager: WHO reply command received
[1=tic01005-gw]
```

---

*Example 5-6 The Controller Proxy log file*

---

```
03/02/12 11:34:39 3 1816 logInit - Message logging initialized (level=3,
logmax=1MB).
03/02/12 11:34:40 1 1816 sendCommandLineRequest: cannot connect to
127.0.0.1:3333
03/02/12 11:34:40 0 1816 Proxy label: tic01005-gw
03/02/12 11:34:40 0 1816 Proxy type: controller
03/02/12 11:34:40 2 1816 No timeout specified, using default
03/02/12 11:34:40 0 1816 Communication timeout: 240
03/02/12 11:34:40 0 1816 Max sessions: 10
03/02/12 11:34:40 0 1816 Reply to RSM data: no
03/02/12 11:34:40 3 1816 initRoutedSessionsManager: no network card specified
for parent-local-host, using random interface
03/02/12 11:34:42 3 1740 routingManager: TELL reply command
received
```

---

Both logs show that the Proxy communication is working.

5. We check if the Controller connects to the Target Proxy by looking at the `remcon.trc`, Example 5-7, checking the value for the `/C` parameter and comparing the result with `rcproxy.log` (Target Proxy log file), Example 5-5.

*Example 5-7 The remcon.trc file*

---

```
[1028] Wed Feb 12 17:35:16 2003 3 found /C parameter
[1028] Wed Feb 12 17:35:16 2003 3 Proxy port is: [5021]
[1028] Wed Feb 12 17:35:16 2003 3 found /E parameter
[1028] Wed Feb 12 17:35:16 2003 3 found /B parameter
[1028] Wed Feb 12 17:35:16 2003 3 EP odnum is 12
[1028] Wed Feb 12 17:35:16 2003 3 CMainFrame::OnCreate - Creating status bar
[1028] Wed Feb 12 17:35:16 2003 3 CMainFrame::OnCreate - Creating resizable
tool bar
[1028] Wed Feb 12 17:35:16 2003 3 Connection with proxy
[1028] Wed Feb 12 17:35:16 2003 3 Connection port is: [5021]
[1028] Wed Feb 12 17:35:43 2003 3 Connection was opened
```

---

From the `rcproxy.log` file in the Example 5-5, we find out that the Proxy listen port is 5020:

```
03/02/12 11:39:23 0 1340 Proxy listen port: 5020
```

While the Controller is trying to connect to port 5021 (Example 5-7):

```
[1028] Wed Feb 12 17:35:16 2003 3 found /C parameter
[1028] Wed Feb 12 17:35:16 2003 3 Proxy port is: [5021]
```

This value is read from the `rc_def_proxy` policy method.

In order to solve this problem, we can either change the `rc_def_proxy` policy method or the `rcproxy.cfg` for the Target Proxy.

In Example 5-8, we change the `rc_def_proxy` policy method as follows in order to solve the problem.

*Example 5-8 The rc\_def\_proxy policy method changes in order to fix the problem*

---

```
#!/bin/sh
# Default value: NO
echo "YES auto 5020" <<===== we replaced 5021 with 5020
exit 0
```

---

### 5.3.2 Case 2: Target Proxy service is not active

In this case we assume that the Target Proxy service is down and the connection between the two Proxies is not working. Based on this scenario we provide troubleshooting examples to discover and solve this issue.

As soon as we start a Remote Control session with the Target Endpoint, we get the error message in Figure 5-5.

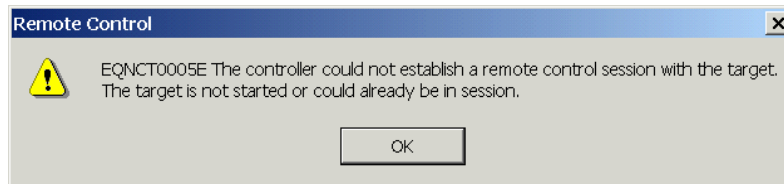

Figure 5-5 Error message displayed on the Controller at session startup

At this point we start the problem determination, taking always as reference the diagrams reported in 5.1, "Generic problem determination outline" on page 142.

1. We check that both Target and Controller Endpoint are alive and that the Framework downcall works against these Endpoints.

Check the Controller Endpoint:

```
wep tic01006 status
tic01006 is alive
```

Check the Target Endpoint:

```
wep tic01007 status
tic01007 is alive
```

2. We assume that Endpoint and Gateway Proxy services are up and running. Then we check Endpoint Proxy, Relay, and Gateway Proxy communication by looking at the epp.log (Example 5-9), gwp.log (Example 5-11) and relay.log (Example 5-10).

Example 5-9 The Endpoint Proxy log file

---

```
03/02/12 15:06:49 3 1860 logInit - Message logging initialized (level=3,
logmax=1MB).
03/02/12 15:06:49 0 1860 Endpoint Proxy version 1.3 - level 20020925
03/02/12 15:06:49 0 1860 Log level 3
03/02/12 15:06:49 0 1860 Maximum log size 1 (MB)
03/02/12 15:06:49 0 1860 Local hostname tic01003
03/02/12 15:06:49 0 1860 Local IP address 9.3.5.29
03/02/12 15:06:49 0 1860 TME Gateway 9.3.4.71+9494
03/02/12 15:06:49 0 1860 TCP/IP timeout 240
03/02/12 15:06:49 0 1860 Accept timeout 300
```

```

03/02/12 15:06:49 0 1860 Database path './'
03/02/12 15:06:49 0 1860 UDP forwarding enabled
03/02/12 15:06:49 0 1860 max sessions 256
03/02/12 15:06:49 3 1860 initGroupHandler - no Proxy groups created
03/02/12 15:06:49 0 1860 Using default port range of 6000-8000
03/02/12 15:06:49 3 1860 FSR0001W Endpoint Proxy Started
03/02/12 15:06:49 0 1860 Initializing the communication layer ...
03/02/12 15:06:49 3 1860 initRoutedSessionsManager: no network card specified
for children-local-host, using random interface
03/02/12 15:06:49 2 1860 initRoutedSessionsManager: children-remote-file
parameter not specified
03/02/12 15:06:49 3 688 routingManager: TELL command received
[1=tic01005-gw]
03/02/12 15:06:49 0 1860 Communication layer initialized
03/02/12 15:06:49 0 1860 Endpoint Proxy initialization successfully completed
03/02/12 15:06:49 3 688 routingManager: WHO reply command received
[1=tic01005-gw]

```

---

The last few lines of the Endpoint Proxy log file show that the Endpoint Proxy is communicating with the Gateway Proxy.

*Example 5-10 The Relay log file*

```

03/02/12 14:20:03 3 844 logInit - Message logging initialized (level=3,
logmax=1MB).
03/02/12 14:20:03 0 844 Relay version 1.3 - level 20020925
03/02/12 14:20:03 0 844 TCP/IP timeout 240
03/02/12 14:20:03 3 844 FSR0001W Relay Started
03/02/12 14:20:03 0 844 Initializing the communication layer ...
03/02/12 14:20:03 3 844 initRoutedSessionsManager: no network card specified
for parent-local-host, using random interface
03/02/12 14:20:03 3 844 initRoutedSessionsManager: no network card specified
for children-local-host, using random interface
03/02/12 14:20:03 2 844 initRoutedSessionsManager: children-remote-file
parameter not specified
03/02/12 14:20:03 3 1544 routingManager: TELL command received
[1=tic01005-gw]
03/02/12 14:20:09 0 844 Communication layer initialized
03/02/12 14:20:09 3 844 Spawn Proxy shutdown monitor thread

```

---

The relay.log file shows that the Relay is communicating with the Gateway Proxy and routing this information to the Endpoint Proxy.

*Example 5-11 The Gateway Proxy log file*

```

03/02/12 15:01:56 3 1144 logInit - Message logging initialized (level=3,
logmax=1MB).
03/02/12 15:01:56 0 1144 Gateway Proxy version 1.3 - level 20020925
03/02/12 15:01:56 0 1144 log level 3

```



```

03/02/12 15:01:56 0 1144 Maximum log size 1 (MB)
03/02/12 15:01:56 3 1144 FSR0001W Gateway Proxy Started
03/02/12 15:01:56 0 1144 gateway port 9494
03/02/12 15:01:56 0 1144 Using 0.0.0.0 for gateway interface
03/02/12 15:01:56 0 1144 TCP/IP timeout 240
03/02/12 15:01:56 0 1144 Gateway Proxy label tic01005-gw.
03/02/12 15:01:56 0 1144 Using default port range of 6000-8000
03/02/12 15:01:56 0 1144 max sessions 256
03/02/12 15:01:56 0 1144 Initializing the communication layer ...
03/02/12 15:01:56 3 1144 initRoutedSessionsManager: no network card specified
for parent-local-host, using random interface
03/02/12 15:02:07 3 1828 routingManager: WHO command received [!=null]
03/02/12 15:02:07 3 1828 routingManager: TELL reply command received
03/02/12 15:02:07 0 1144 Communication layer initialized
03/02/12 15:02:07 3 1144 Run Gateway listener (on Gateway port = 9494)
03/02/12 15:02:07 3 1144 Run UDP listener (on Gateway port = 9494)
03/02/12 15:02:07 0 1144 Gateway Proxy initialization successfully completed

```

---

The Gateway Proxy.log file shows that the Gateway Proxy is communicating with the Endpoint Proxy. So until now, everything seems to be working from Framework point of view.

- Now we need to check what happens at Controller and Target Proxy level, and if the two Proxies have communication problems.

First we look to see if the services are up and running, and we notice that the RC Target Proxy is down.

Example 5-12, Example 5-13, and Example 5-14, respectively, show the Target Proxy, Relay, and Controller Proxy log files when there is a session startup failure caused by the Target Proxy service being down.

*Example 5-12 The Target Proxy log file*

---

```

03/02/12 15:06:53 3 1760 logInit - Message logging initialized (level=3,
logmax=1MB).
03/02/12 15:06:54 1 1760 sendCommandLineRequest: cannot connect to
127.0.0.1:3333
03/02/12 15:06:54 0 1760 Proxy label: none (node is root)
03/02/12 15:06:54 0 1760 Proxy type: target
03/02/12 15:06:54 2 1760 No listen interface specified, defaulting to
INADDY_ANY
03/02/12 15:06:54 0 1760 Proxy listen port: 5020
03/02/12 15:06:54 0 1760 TFST Endpoint Proxy directory: C:\Tivoli\Tivoli
Systems\Tivoli Endpoint Proxy
03/02/12 15:06:54 2 1760 No timeout specified, using default
03/02/12 15:06:54 0 1760 Communication timeout: 240
03/02/12 15:06:54 0 1760 Max sessions: 10
03/02/12 15:06:54 0 1760 Reply to RSM data: no

```

```
03/02/12 15:06:54 3 1760 initRoutedSessionsManager: no network card specified
for children-local-host, using random interface
03/02/12 15:06:54 2 1760 initRoutedSessionsManager: children-remote-file
parameter not specified
03/02/12 15:06:54 3 1736 routingManager: TELL command received
[l=tic01005-gw]
03/02/12 15:06:55 3 1736 routingManager: WHO reply command received
[l=tic01005-gw]
```

---

*Example 5-13 The Relay log file (instance used by remote control proxies)*

---

```
03/02/12 14:24:34 3 1544 logInit - Message logging initialized (level=3,
logmax=1MB).
03/02/12 14:24:34 0 1544 Relay version 1.3 - level 20020925
03/02/12 14:24:34 0 1544 TCP/IP timeout 240
03/02/12 14:24:34 3 1544 FSR0001W Relay Started
03/02/12 14:24:34 0 1544 Initializing the communication layer ...
03/02/12 14:24:34 3 1544 initRoutedSessionsManager: no network card specified
for parent-local-host, using random interface
03/02/12 14:24:34 3 1544 initRoutedSessionsManager: no network card specified
for children-local-host, using random interface
03/02/12 14:24:34 2 1544 initRoutedSessionsManager: children-remote-file
parameter not specified
03/02/12 14:24:34 3 1192 routingManager: TELL command received
[l=tic01005-gw]
03/02/12 14:24:36 3 1192 routingManager: WHO reply command received
[l=tic01005-gw]
03/02/12 14:24:36 3 304 routingManager: TELL reply command received
03/02/12 14:24:36 0 1544 Communication layer initialized
03/02/12 14:24:36 3 1544 Spawn Proxy shutdown monitor thread
03/02/12 14:24:36 3 304 routingManager: TELL reply command received
03/02/12 14:25:36 1 320 ERROR tcpunidir.thread.peer2peer: socket error 10054
```

---

*Example 5-14 The Controller Proxy log file*

---

```
03/02/12 15:02:02 3 2224 logInit - Message logging initialized (level=3,
logmax=1MB).
03/02/12 15:02:03 1 2224 sendCommandLineRequest: cannot connect to
127.0.0.1:3333
03/02/12 15:02:03 0 2224 Proxy label: tic01005-gw
03/02/12 15:02:03 0 2224 Proxy type: controller
03/02/12 15:02:03 2 2224 No timeout specified, using default
03/02/12 15:02:03 0 2224 Communication timeout: 240
03/02/12 15:02:03 0 2224 Max sessions: 10
03/02/12 15:02:03 0 2224 Reply to RSM data: no
03/02/12 15:02:03 3 2224 initRoutedSessionsManager: no network card specified
for parent-local-host, using random interface
03/02/12 15:02:10 3 948 routingManager: WHO command received [l=null]
```

---

### 5.3.3 Case 3: Wrong Proxy configuration

In this case we assume that the Target Proxy is not configured properly and the communication between remote control proxies does not work, while the gateway and Endpoint Proxy communication works fine. Based on this scenario we provide troubleshooting examples to discover and solve this issue.

As soon as we start the session, we get the error message in Figure 5-6.

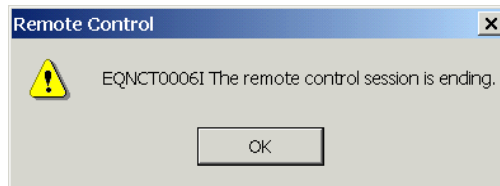

Figure 5-6 Error message at session startup: Proxy configuration problem

We assume that Target and Controller Endpoint are alive and everything works from Framework point of view. We assume also that the Remote Control Proxies services are up and running. So we skip these checks in this example.

We directly analyze the Remote Control Proxy Target and Controller log files, and since our environment uses a Relay, we also analyze the relay.log:

First we analyze the Target Proxy log file as in Example 5-15.

Example 5-15 The remote control Target Proxy log file

---

```
03/02/12 16:09:15 3 1920 logInit - Message logging initialized (level=3,
logmax=1MB).
03/02/12 16:09:16 1 1920 sendCommandLineRequest: cannot connect to
127.0.0.1:3333
03/02/12 16:09:16 0 1920 Proxy label: none (node is root)
03/02/12 16:09:16 0 1920 Proxy type: target
03/02/12 16:09:16 2 1920 No listen interface specified, defaulting to
INADDY_ANY
03/02/12 16:09:16 0 1920 Proxy listen port: 5020
03/02/12 16:09:16 0 1920 TFST Endpoint Proxy directory: C:\Tivoli\Tivoli
Systems\Tivoli Endpoint Proxy
03/02/12 16:09:16 2 1920 No timeout specified, using default
03/02/12 16:09:16 0 1920 Communication timeout: 240
03/02/12 16:09:16 0 1920 Max sessions: 10
03/02/12 16:09:16 0 1920 Reply to RSM data: no
03/02/12 16:09:16 3 1920 initRoutedSessionsManager: no network card specified
for children-local-host, using random interface
```

```

03/02/12 16:09:16 2 1920 initRoutedSessionsManager: children-remote-file
parameter not specified
03/02/12 16:09:17 1 1920 tcpunidir.open [line=683]: connect() failed (e=9,
le=10061, wsa_le=10061)
03/02/12 16:09:17 1 1920 tcpunidir.open: cannot connect to 9.3.4.248+7021
03/02/12 16:09:17 1 1920 ERROR tcpunidir.open: cannot open connection
03/02/12 16:09:17 1 1920 ERROR multiplex.newsessopen: cannot open connection
(type=RM, err=-1)
03/02/12 16:16:46 1 2200 getRoute: sessions manager not found [l=tic01005-gw]
03/02/12 16:16:46 1 2200 routedSessionCreate: routing manager did not return
a valid sessions manager [l=tic01005-gw]
03/02/12 16:16:46 1 2200 threadSetupSessionFromSocket: cannot create routed
session

```

---

From the Target Proxy log file we see that the Target Proxy is not able to connect to the machine 9.3.4.248 on port 7021.

This IP address refers to the machine tic01004, the Relay machine. So, the second step is to analyze the Relay log file as in Example 5-16.

*Example 5-16 The remote control Relay log file*

---

```

03/02/12 16:12:23 3 1172 logInit - Message logging initialized (level=3,
logmax=1MB).
03/02/12 16:12:23 0 1172 Relay version 1.3 - level 20020925
03/02/12 16:12:23 0 1172 TCP/IP timeout 240
03/02/12 16:12:23 3 1172 FSR0001W Relay Started
03/02/12 16:12:23 0 1172 Initializing the communication layer ...
03/02/12 16:12:23 3 1172 initRoutedSessionsManager: no network card specified
for parent-local-host, using random interface
03/02/12 16:12:23 3 1172 initRoutedSessionsManager: no network card specified
for children-local-host, using random interface
03/02/12 16:12:23 2 1172 initRoutedSessionsManager: children-remote-file
parameter not specified
03/02/12 16:12:23 3 972 routingManager: TELL command received
[l=tic01005-gw]
03/02/12 16:12:29 0 1172 Communication layer initialized
03/02/12 16:12:29 3 1172 Spawn Proxy shutdown monitor thread
03/02/12 16:16:39 1 1832 ERROR tcpunidir.thread.peer2peer: socket error 10054

```

---

From the relay.log file we see that the Relay gets a communication error, since it is not able to communicate with its parent.

The we look at the Controller Proxy log file as in Example 5-17.

*Example 5-17 The remote control Controller log file*

---

```
03/02/12 16:03:34 3 1820 logInit - Message logging initialized (level=3,
logmax=1MB).
03/02/12 16:03:35 1 1820 sendCommandLineRequest: cannot connect to
127.0.0.1:3333
03/02/12 16:03:35 0 1820 Proxy label: tic01005-gw
03/02/12 16:03:35 0 1820 Proxy type: controller
03/02/12 16:03:35 2 1820 No timeout specified, using default
03/02/12 16:03:35 0 1820 Communication timeout: 240
03/02/12 16:03:35 0 1820 Max sessions: 10
03/02/12 16:03:35 0 1820 Reply to RSM data: no
03/02/12 16:03:35 3 1820 initRoutedSessionsManager: no network card specified
for parent-local-host, using random interface
03/02/12 16:04:33 3 1876 routingManager: WHO command received [l=null]
03/02/12 16:04:33 3 1876 routingManager: TELL reply command received
03/02/12 16:10:06 3 872 logInit - Message logging initialized (level=3,
logmax=1MB).
03/02/12 16:10:07 1 872 sendCommandLineRequest: cannot connect to
127.0.0.1:3333
03/02/12 16:10:07 0 872 Proxy label: tic01005-gw
03/02/12 16:10:07 0 872 Proxy type: controller
03/02/12 16:10:07 2 872 No timeout specified, using default
03/02/12 16:10:07 0 872 Communication timeout: 240
03/02/12 16:10:07 0 872 Max sessions: 10
03/02/12 16:10:07 0 872 Reply to RSM data: no
03/02/12 16:10:07 3 872 initRoutedSessionsManager: no network card specified
for parent-local-host, using random interface
```

---

No relevant errors are shown in the Controller Proxy log file.

At this point we need to check if there are configuration errors comparing the settings showed in the log file with the related proxies configuration files.

In order to verify the Target Proxy settings, we need to analyze the Relay.cfg file to check that the Target Proxy is using the correct ports and hostname to connect to the Relay, comparing the log file information with the Relay configuration one.

*Example 5-18 The Relay configuration file*

---

```
[communication-layer]
children-local-port=7021
children-remote-list=tic01005+8020
parent-local-port=7020
parent-remote-host=tic01003
parent-remote-port=6020
```

```
parent-cm-type=cm-tcp-unidirectional
children-cm-type=cm-tcp-unidirectional
[log]
log-file=relay.log
debug-level=3
max-size=1
[parent-cm-info]
connection-mode=server
[children-cm-info]
connection-mode=client
local-port-range=4023
```

---

From the configuration file, we find that the Relay uses port 7020 to communicate with the Target Proxy, but the Target Proxy looks for port 7021, as shown in Example 5-15. This means that the rcproxy.cfg of the Target Proxy needs to be changed accordingly. Example 5-19 shows the configuration error we need to fix in the rcproxy.cfg file, highlighting the line that needs to be changed.

*Example 5-19 Wrong Target Proxy configuration file*

---

```
[log]
log-file=rcproxy.log
debug-level=3
max-size=1
[rcproxy]
epp-directory=C:\Tivoli\Tivoli Systems\Tivoli Endpoint Proxy
proxy-port=5020
proxy-type=target
cmdline-port=3333
[communication-layer]
children-local-port=6020
children-remote-list=tic01004+7021 <<=====ERROR
children-cm-type=cm-tcp-unidirectional
buffer-size=1024
[children-cm-info]
connection-mode=client
local-port-range=4000
```

---

Port 7021 needs to be replaced by 7020.

## 5.4 Troubleshooting the firewall

This section describes some of the important points to consider if things go wrong in the firewall environment. The firewall is an important entity when it comes to Tivoli network management across firewalls. There is every chance that some troubleshooting will be required on the firewall to check that firewall rules are properly set up to allow the permitted traffic and deny the unwanted traffic.

These are some points to consider from the firewall point of view if things go wrong in this environment:

1. The firewall log is an important source of information, and this is the one to check first for everything that goes wrong with the firewall environment. The firewall log provides information with the date and time of each log entry, along with some reasoning for the particular log entry. So, you need to analyze the log for any possible problem causes.
2. IBM SecureWay firewall log entries are associated with some tags to identify them, called ICA tags. The IBM SecureWay firewall reference manual that comes with firewall installation gives the troubleshooting information with respect to each ICA tag that is related to some error condition.
3. The problem could be due to some incorrectly configured firewall rules. Check the firewall rules and make sure that everything is set up according to these requirements. This may seem simple, but do make sure you have the firewall rules set up properly for Target Proxy/Relay/Controller Proxy communication. These rule settings must be documented in the standard security documentation, as advised in Chapter 2, "Implementation planning" on page 57.
4. Check to see if there are any alerts generated by the firewall for any possible problem cause.
5. Take the `iptrace` on the firewall machine and see that the required traffic has no problem passing through the firewall. If any problem is found with required traffic across the firewall, check to see if the rules defined are correct or have anything to do this.
6. Some firewall implementations close ports on open connections if they have not been used within a time period. In such cases, it is important that you come to an understanding with the firewall administrators on what firewall policies have to be in place. Take into account that communication between Target Proxies, Relays, and Controller Proxies are established at startup time.
7. Some firewalls are equipped with in built debugging tools. These tools can collect some sort of debug information when a particular activity is carried out. This debug information, in turn, can help analyze and correct the problem.

8. When you alter any configuration on the firewall, some services require that you stop and restart those services. Check if you are missing this point for any of the services or configuration changes you made.
9. Check **netstat -rn** command output and make sure the routing information on the firewall is proper. Check **netstat -an** command output and see that the required protocol ports are in the proper state (listening/established). There are various other sniffer and monitoring tools that give the network status and can be helpful in tracing the problem.
10. Firewall rules are set based on the direction. So, decide on the parent and child relation among target/Relay/Controller Proxies and set the rules accordingly. You need an additional set of rules if you want the traffic flow to be bidirectional (that is, if the initiator can be from both the sides of firewall).
11. It is always recommended that you do not have any other load on the firewall machine. Also see that your machine satisfies all the hardware and software requirements for the specific firewall installation and functionality.





# Part 4

# Appendixes





# A

## **Tivoli Firewall Security Toolbox overview**

In this appendix we provide a brief overview of Tivoli Firewall Security Toolbox, (TFST). We present the basic ideas on the purpose, installation, configuration, and usage of TFST. For additional information, refer to the *Firewall Security Toolbox User 's Guide*, GC23-4826.

## Introduction

Tivoli Firewall Security Toolbox enables Tivoli network management across firewalls without compromising security. When one or more firewalls exist between Endpoint and Gateway, the communication channels permitted by the firewall are limited. The Tivoli firewall Security Toolbox enables the Endpoint and Gateway communication across firewalls while respecting firewall restrictions. In a TFST scenario, the Endpoint Proxy on the secure side and the Gateway Proxy on the less secure side communicate with each other using proprietary Tivoli protocol encapsulated TCP/IP packets through the firewall.

## Components of TFST

In the following sections we describe the four components that make up Tivoli Firewall Security Toolbox:

- ▶ Endpoint Proxy
- ▶ Gateway Proxy
- ▶ Relay
- ▶ Event Sink

### Endpoint Proxy

This component is utilized by the Tivoli Gateway on the secure side and this emulates the Tivoli Endpoint for the Gateway in TME Framework. This in turn establishes the connection with the Gateway Proxy across the firewall on behalf of Tivoli Gateway.

### Gateway Proxy

This component is installed in the less secure side or DMZ to emulate a Tivoli Gateway. This is connected to the Tivoli Endpoints on the less secure side and Tivoli Endpoints are configured to point to this as their Gateway.

### Relay

The Relay allows the Endpoints to be manageable even if they are separated from their Gateway by multiple firewalls, and this component is placed between layers of firewall to manage the Endpoints. The main purpose of the Relay is to pass the information as it is received up or down the chain to the Endpoint Proxy, the Gateway Proxy, or other Relay components in the chain.

## Event Sink

This component emulates the Tivoli Enterprise Console® (TEC) Server. All non-TME adapters served by this Event Sink are configured to point to this as their TEC Server. In the firewall environment where the firewall separates non-TME adapter machine from the Gateway, the Event Sink collects the events sent from non-TME adapters as if it were a TEC server and sends the events to the TEC server. The Event Sink can collect the events from multiple non-TME adapters.

## Tivoli environments with single firewall

On the secure side of the firewall, TFST provides an Endpoint Proxy that connects to the Gateway as if it were the Endpoints. On the less secure side of firewall, Endpoints are connected to the Gateway Proxy as if it were the Gateway. The Gateway Proxy and Endpoint Proxy communicate with each other through the firewall. Figure A-1 shows a simple configuration with one Gateway Proxy and one Endpoint Proxy.

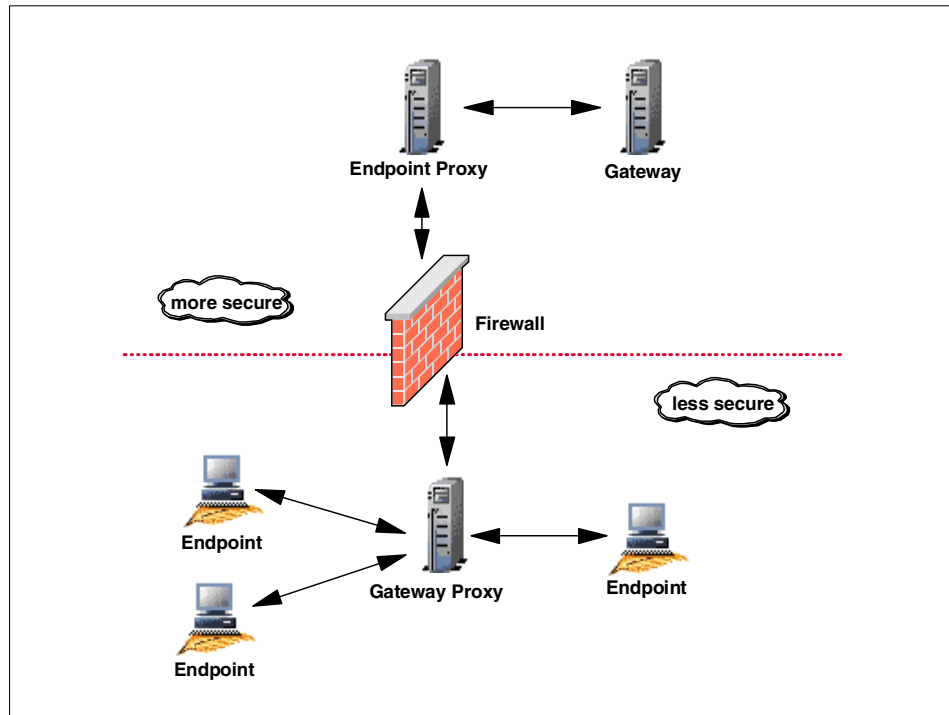

Figure A-1 Tivoli Endpoint and Gateway proxies communication through firewall

Just as multiple Gateways can connect to a single Gateway and multiple Gateways to a single Tivoli server, multiples Endpoints can connect to a single Gateway Proxy and multiple Gateway proxies can connect to a single Endpoint Proxy. And the communication between these Tivoli components is based on a Tivoli Proprietary protocol over TCP/IP.

## Tivoli environments with multiple firewalls

In this scenario, although Gateway Proxy and Endpoint Proxy continue to communicate with Endpoint and Gateway respectively, they no longer communicate directly across multiple firewalls. Instead, TFST provides Relays, which are installed between the layers of firewall in DMZs. These Relays pass on the information from each other and finally to/from the Endpoint Proxy and the Gateway Proxy. Figure A-2 shows an example of this configuration.

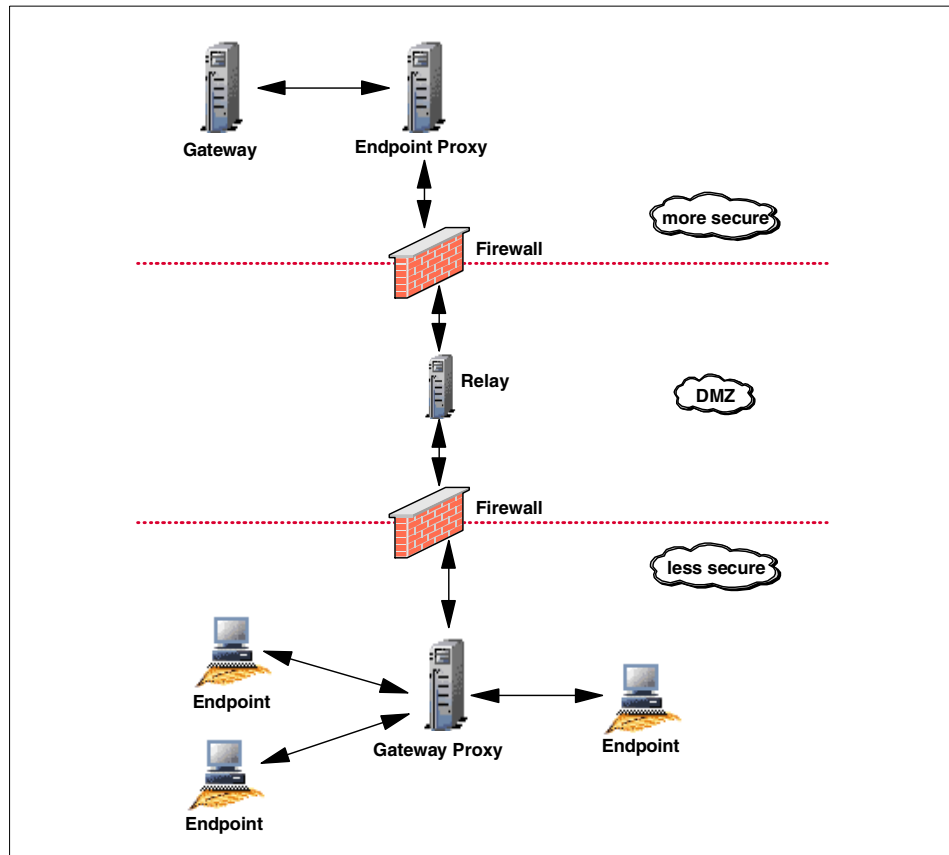

Figure A-2 Relay connecting Endpoint and Gateway proxies through a DMZ

## Sending events across firewalls

Tivoli adapters use Endpoints to send events to the TEC Server through Tivoli connections. When the firewall separates the Endpoint from the TEC server, the machines connect through the Gateway and Endpoint Proxies. Machines that are not part of the Tivoli environment use non-TME adapters to send events to TEC servers through non-Tivoli connections.

When the firewall separates the non-TME adapter machine from the Gateway, TFST provides the Event Sink, which sends the events to the TEC server. The Event Sink, which is installed on an Endpoint outside the firewall, collects the events sent from non-TME adapters as if it were a TEC server and sends them to the TEC server as though they were TME events. Figure A-3 shows the Event Sink collecting events from non-TME adapters and sending them to the TEC server through the firewall.

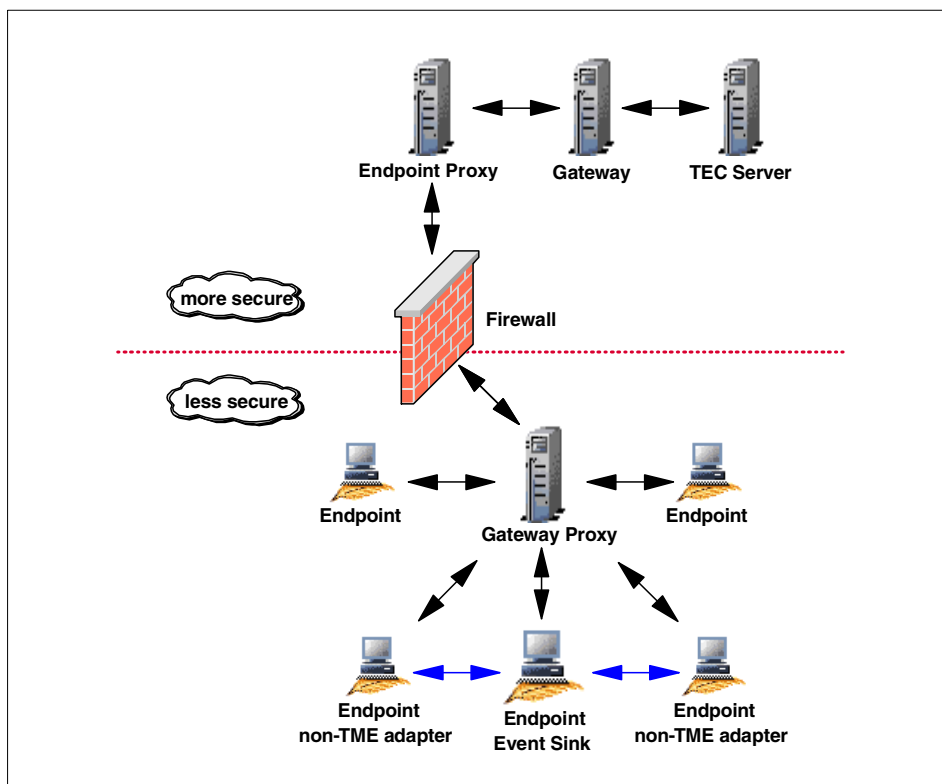

Figure A-3 Event Sink collecting non-TME events

# Installation and configuration of TFST

This section explains how to install and configure the components of Tivoli Firewall Security Toolbox.

## Installation of TFST

Refer to the *Firewall Security Toolbox User's Guide*, GC23-4826, for the prerequisite software and hardware details of Tivoli Firewall Security Toolbox.

To install TFST, decompress the tar file or self-extracting EXE file. Under the main Proxy directory, the file creates directories for each component and copies the installation scripts and executables to subdirectories for each platform.

### Installing the Endpoint Proxy

To install Tivoli Endpoint Proxy, decompress the tar file or self-extracting EXE file, and it will create the Endpoint directory under the main Proxy directory:

- ▶ To install Endpoint Proxy on a UNIX based machine, run **install.sh** from the Endpoint Proxy directory and follow the steps provided in the *Firewall Security Toolbox User's Guide*, GC23-4826.
- ▶ To install Endpoint Proxy on a Windows based machine, run **Tivoli Endpoint Proxy.exe** present under Tivoli Endpoint Proxy\w32-ix86 subdirectory, and the InstallShield starts. Then follow the steps provided in the *Firewall Security Toolbox User's Guide*, GC23-4826.

### Installing the Gateway Proxy

Tivoli Gateway Proxy needs to be installed on a machine that is in the DMZ, where the Endpoints are located. From the Gateway Proxy directory, go to the directory for the platform on which the Proxy will run:

- ▶ To install Endpoint Proxy on UNIX based machine, run **install.sh** from the Gateway Proxy directory and follow the steps provided in *Firewall Security Toolbox User's Guide*, GC23-4826.
- ▶ To install Endpoint Proxy on windows, run **Tivoli Gateway Proxy.exe** present under Tivoli Gateway Proxy\w32-ix86 subdirectory, and the InstallShield starts. Then follow the steps provided in the *Firewall Security Toolbox User's Guide*, GC23-4826.



## Installing Relay instances

You can install multiple instances of Relay on the same machine. Do the following to install the first Relay instance:

- ▶ To install Relay on a UNIX based machine, go to the Relay directory and then to the subdirectory for the platform on which Relay will run and run **install.sh** from the subdirectory. Follow the steps provided in *Firewall Security Toolbox User's Guide*, GC23-4826.
- ▶ To install Relay on a Windows machine, run **setup.exe** from the directory that contains the Tivoli Relay Installation Images and the Tivoli Relay InstallShield wizard starts. Then follow the steps provided in *Firewall Security Toolbox User's Guide*, GC23-4826.

## Installing the Event Sink

The Event Sink is to be installed on an Endpoint, as follows:

- ▶ To install Event Sink on a UNIX machine, go to the Event Sink directory and then to the subdirectory for the platform on which the Proxy will run and run **install.sh** from the subdirectory. Follow the steps provided in *Firewall Security Toolbox User's Guide*, GC23-4826.
- ▶ To install Event Sink on a Windows machine, run **EventSink.exe** located under Event Sink\w32-ix86 subdirectory. The Tivoli Event Sink InstallShield wizard starts. Then follow the steps provided in *Firewall Security Toolbox User's Guide*, GC23-4826.

## Configuration of TFST

This section covers the configuration of the various components of Tivoli Firewall Security Toolbox.

### Configuring the Endpoint Proxy

After you install Endpoint Proxy, the configuration file `epProxy.cfg` is created in the directory where you installed the Proxy. It contains the configuration input supplied during installation. In addition, you can edit this with a text editor to configure other options. You have to stop and restart the component to make any changes to this configuration. The configuration file contains different sections, and each section has a table for keywords and comments. Note that the section titles are case sensitive. Enter the values in the following format.

```
keyword=value
```

Following are the different sections available:

### **Endpoint Proxy**

The [Endpoint-Proxy] section lists the mail options for the Endpoint Proxy. Refer to Table 2 in the *Firewall Security Toolbox User 's Guide*, GC23-4826, under “Configuring the Endpoint Proxy” subsection for the [Endpoint-Proxy] keywords and their descriptions available.

### **Log**

The [log] section lists the log options. Refer to Table 3 in the *Firewall Security Toolbox User 's Guide*, GC23-4826 under “Configuring the Endpoint Proxy” subsection for the [log] keywords and their descriptions available.

### **Communication Layer**

The [communication-layer] lists the options on how the Endpoint Proxy connects to its Relays or Gateway proxies. Refer to Table 4 in the *Firewall Security Toolbox User 's Guide*, GC23-4826 under “Configuring the Endpoint Proxy” subsection for the [communication-layer] keywords and their descriptions available.

### **Children-cm-info**

The [children-cm-info] lists further options about connectivity between the Endpoint Proxy and its children (Relays or Gateway proxies). Refer to Table 5 in the *Firewall Security Toolbox User 's Guide*, GC23-4826 under “Configuring the Endpoint Proxy” subsection for the [children-cm-info] keywords and their descriptions available.

## **Configuring Gateway Proxy**

After you install Gateway Proxy, the configuration file `gwProxy.cfg` is created in the directory in which the Proxy is installed. This file contains the configuration input provided during installation. In addition, to provide other options or change the existing configuration, you can edit `gwProxy.cfg` with a text editor. You have to stop and restart the component to make your changes effective. The configuration file contains different sections and each section has a table for keywords and comments. Note that the section titles are case sensitive. And enter the values in the following format.

```
keyword=value
```

Following are the different sections available:

### **Gateway-Proxy**

The [Gateway-Proxy] section lists the main options for the Gateway Proxy. Refer to Table 6 in the *Firewall Security Toolbox User 's Guide*, GC23-4826 under “Configuring the Gateway Proxy” subsection for the [Gateway-Proxy] keywords and their descriptions available.

### **Log**

The [log] section lists the log options. Refer to Table 7 in the *Firewall Security Toolbox User 's Guide*, GC23-4826 under “Configuring the Gateway Proxy” subsection for the [log] keywords and their descriptions available.

### **Communication-layer**

The [communication-layer] lists the options on how the Gateway Proxy connects to its Relay or Endpoint Proxy. Refer to Table 8 in the *Firewall Security Toolbox User 's Guide*, GC23-4826 under “Configuring the Gateway Proxy” subsection for the [communication-layer] keywords and their descriptions available.

### **Parent-cm-info**

The [parent-cm-info] section lists further options about connectivity between Gateway Proxy and its parent (Relay or Endpoint Proxy). Refer to Table 9 in the *Firewall Security Toolbox User 's Guide*, GC23-4826 under “Configuring the Gateway Proxy” subsection for the [parent-cm-info] keywords and their descriptions available.

## **Configuring the Relay**

After you install Relay, the configuration file `Relay.cfg` is created in the directory in which the component is installed. This file contains the configuration input provided during installation. In addition, to provide other options or change the existing configuration, you can edit `Relay.cfg` with a text editor. You have to stop and restart the component to make your changes effective. The configuration file contains different sections and each section has a table for keywords and comments. Note that the section titles are case sensitive. And enter the values in the following format.

```
keyword=value
```

Following are the different sections available:

### **Relay**

The [Relay] section is required at the top of the file even when you do not specify any keywords. Refer to Table 10 in the *Firewall Security Toolbox User 's Guide*, GC23-4826 under “Configuring the Relay” subsection for the [Relay] keywords and their descriptions available.

## **Log**

The [log] section lists the log options. Refer to Table 11 in the *Firewall Security Toolbox User's Guide*, GC23-4826 under “Configuring the Relay” subsection for the [log] keywords and their descriptions available.

## **Communication layer**

The [communication-layer] section lists the options on how the Relay connects to its parent and children, Relays, Endpoint Proxy or Gateway Proxy. Refer to Table 12 in the *Firewall Security Toolbox User's Guide*, GC23-4826 under “Configuring the Relay” subsection for the [communication-layer] keywords and their descriptions available.

## **Children-cm-info**

The [children-cm-info] lists further options about connectivity between the Relay and its children (Relays or Gateway proxies). Refer to Table 13 in the *Firewall Security Toolbox User's Guide*, GC23-4826 under “Configuring the Relay” subsection for the [children-cm-info] keywords and their descriptions available.

## **parent-cm-info**

The [parent-cm-info] section lists further options about connectivity between Relay and its parent (Relay or Endpoint Proxy). Refer to Table 14 in the *Firewall Security Toolbox User's Guide*, GC23-4826 under “Configuring the Relay” subsection for the [parent-cm-info] keywords and their descriptions available.

## **Configuring the Event Sink**

After you install Event Sink, the configuration file `eventsink.cfg` is created in the directory in which the component is installed. This file contains the configuration input provided during installation.

**Note:** You must configure every non-TME event generator to point to the Event Sink as its TEC server. To configure non-TME adapters, refer to “Non-TME adapters for the Event Sink” in *Firewall Security Toolbox User's Guide*, GC23-4826.

To provide other options or change the existing configuration, you can edit `eventsink.cfg` with a text editor. You have to stop and restart the component to make your changes effective. The configuration file contains different sections and each section has a table for keywords and comments. Note that the section titles are case sensitive. Enter the values in the following format.

```
keyword=value
```

Following are the different sections available:

### **SENDING**

The [SENDING] section lists the options for sending events to the TEC server. Refer to Table 15 in the *Firewall Security Toolbox User's Guide*, GC23-4826 under “Configuring the Event Sink” subsection for the [SENDING] keywords and their descriptions available.

### **RECEPTION**

The [RECEPTION] section lists the options for receiving events from non-TME adapters. Refer to Table 16 in the *Firewall Security Toolbox User's Guide*, GC23-4826 under “Configuring the Event Sink” subsection for the [RECEIVING] keywords and their descriptions available.

### **EIF**

The [EIF] section lists the options for Tivoli Enterprise Integration Facility.

**Note:** You can optionally have the Event Sink forward non-TME events to TEC server as if it were a TEC adapter. To do this, you configure the EIF parameters here like you do for normal adapter. Refer to the *Tivoli Event Integration Facility: User's Guide* for the keywords, formats, and values that apply.

Refer to Table 17 in the *Firewall Security Toolbox User's Guide*, GC23-4826, under “Configuring the Event Sink” subsection for the [EIF] keywords and their descriptions available. Note that ServerLocation parameter in the keyword list here must be specified only if you are configuring the Event Sink to be TEC adapter.

### **Log**

The [log] section lists the log options. Refer to Table 18 in the *Firewall Security Toolbox User's Guide*, GC23-4826, under “Configuring the Event Sink” subsection for the [log] keywords and their descriptions available.

## TFST components and operations

In this section, we discuss the port requirements for the operations of Tivoli Firewall Security Toolbox components in general and Endpoint Proxy and Gateway Proxy in particular.

Each component of TFST (Endpoint Proxy, Gateway Proxy and Relay) will use source and destination ports. TFST gives you the policies to control this port allocation. Note that TFST components can act as both client and server depending on the direction the connection is initiating from. Connections are established when the TMF components such as Gateway or Endpoint initiates the connection. Connection behavior is also governed by the TFST connection policy. Both bidirectional and unidirectional modes are supported:

1. **Source port:** The source port is allocated on the client side of TCP/IP connection by the operating system that is hosting the TFST component. However, TFST does give a way to control the selection of this port range, so that its possible to control which ports are used to connect from. The port-range variable is the policy to control this.
2. **Destination port:** The destination port is the one the server listens on for connections. This port number impacts firewall configuration because TFST components must connect to the server through the firewall to talk to each other. The destination port is controlled by allocating a single listening port per Proxy component.

### Port range configurations

This section describes the various parameters and configuration that govern the port range usage of an Endpoint Proxy and Gateway Proxy:

- ▶ The port-range parameter is the range of ports used by the application (Gateway Proxy or Endpoint Proxy) to connect to their Tivoli counterparts i.e Endpoint Proxy to Gateway and Gateway Proxy to Endpoint.
- ▶ The local-port-range parameter is the range used by the application to connect to their peers (Endpoint Proxy, Relay and Gateway Proxy)
- ▶ The children-local-port parameter is the port on which Endpoint Proxy listens for connections from Relay or Gateway Proxy (Relay uses this port parameter to listen to its children Relay or Gateway Proxy).
- ▶ The parent-local-port parameter is the port on which the Gateway Proxy listens for connections from Endpoint Proxy or Relay. (Relay uses this port parameter to listen from its parent Relay or Endpoint Proxy).

## **Effective Utilization of TFST across firewalls**

The following key points of TFST provide minimum filter rules on the firewall and securely and efficiently configure Tivoli Management Framework across firewalls:

- ▶ Select the Endpoint Proxy to the Relay or Gateway Proxy as unidirectional to permit connections initiated by only one machine.
- ▶ Select the Relay connect to the parent Relay or Endpoint Proxy as unidirectional to permit connections initiated by only one machine.
- ▶ Select the Relay connect to the child Relay or Gateway Proxy as bidirectional to permit connections initiated by either machine.
- ▶ Select the Gateway Proxy connect to the Relay or Gateway Proxy as bidirectional to permit connections initiated by either machine.







# B

## Introducing firewalls

In this appendix we provide a basic overview of firewalls to give you an understanding of the various firewall functionalities, the important tools and components of firewalls, and some of the available firewall products in the market.

## Introduction

A firewall is basically a security solution operating between one or more secure, internal private networks and other (non-secure) networks or the Internet. The main objective of a firewall is to prevent unwanted or unauthorized communication into or out of the secure network. The concept of firewalls started with this basic objective, but has extended its usage and functionality to the changing needs of this corporate world.

## Functionality of a firewall

Some of the objectives and functionality of the firewall as a complete enterprise security solution include these:

1. Selective network access to authorized users from both internal and external networks
2. Use of strong authentication techniques before granting access to sensitive corporate data
3. Ensuring privacy and integrity of data sent across public networks like internet
4. Content security at the gateway to screen the malicious or unwanted content
5. Ability to detect and defeat network attacks and misuse in real time
6. Hiding internal network and conserving IP addresses
7. Ensuring high availability of network resources
8. Detailed logging and accounting information of all the important network activities across the firewall to help the administrators

## Firewall tools

Following are some of the important tools and components provided by the firewalls in order to achieve the foregoing objectives and functionality:

- ▶ Packet filters
- ▶ Proxy servers
- ▶ Socks
- ▶ Authentication
- ▶ DNS and mail gateways
- ▶ Network address translation
- ▶ Virtual private networks
- ▶ Log management

We provide a brief overview of each firewall tool and its components to give you a general understanding of each of these features.

## **Packet filters**

Packet filters are the tools that inspect the information coming in and going out of the network packet by packet. Packet filters inspect packets at the session level based upon multiple criteria such as time of day, source/destination IP address and port number, packet type, and subnet. The filter rules work with the IP gateway function so the machine is required to have two or more network interfaces, each in a separate IP network or subnet. One set of interfaces is declared non-secure and the other set is declared secure. The filter acts between these two sets of interfaces. Packet filtering provides the basic protection mechanism for the firewall. Filters allow you to determine what kind of traffic can pass across the firewall based on IP session details, thereby protecting the secure network from external threats such as scanning for secure servers or IP address spoofing. Packet filters act as the base on which the other higher layer firewall tools can be constructed.

### **Stateful packet filtering**

Some firewalls in the market do implement packet filtering based on state of the session and hence the packet filters being stateful. Every time the connection is established/attempted, the firewall maintains the session details and the state of connection for that session and packet filtering happens, depending on the state diagram for that particular protocol (that is, deciding on what kinds of packets to allow, depending on the state diagram, unlike the stateless packet filters which just allow any permit rule match). But these kinds of stateful packet filters are more prone to DoS attacks, as compared with stateless packet filters.

## **Proxy servers**

Proxies are application level gateways. Unlike filtering, which inspects the packets passing through, proxies perform specific TCP/IP functions on behalf of a network user. There exist a separate proxy for each application, that is, http proxy, telnet proxy, ftp proxy, etc., and they all run on the predefined application ports. Hence, this doesn't require any special client software to connect to proxy servers, and normal clients specific to the application can be used.

The user contacts the proxy server using one of the TCP/IP applications. The proxy server then contacts with the remote host on behalf of the user, thus controlling access while hiding your internal network structure from external users.

This means that, when connecting through a proxy server, the TCP/IP connections are broken at the firewall, so the potential for compromising the secure network is reduced. Users may be required to authenticate themselves, using one of a number of authentication methods.

One major advantage inherent in proxy servers is internal address hiding. All outbound proxy connections use the firewall address. Another major advantage of the proxy server is security. Proxy servers are designed to guard against security weaknesses, which might be on the client machine.

## **Socks**

Socks is a circuit-level gateway that hides the internal network. The Socks server is similar to a proxy server in that the session is broken at the firewall. The difference is that Socks can support all applications instead of requiring a unique proxy for each application. This requires a special “Socksified” client software (client that is Socks-aware) to connect to the Socks server. Socksified clients are available with many applications like Netscape Navigator or Microsoft Internet Explorer, or through TCP/IP software such as Avenail AutoSocks. Socks Protocol Version 5 is the latest standard, which enables the clients to pass an authentication stage before accessing applications on the other side of network.

## **Authentication**

Firewalls can authenticate users with a variety of authentication methods. Users can access useful information on the Internet, without compromising the security of their internal networks.

Authentication just means, use of a password or a stronger method to access your network. This is especially useful when you want to log in remotely, such as when you are traveling or working at home. firewalls can authenticate users with a variety of authentication methods. Users can access useful information on the Internet, without compromising the security of their internal networks.

We describe two of the stronger and more sophisticated methods we tested here to help the user understand this topic: tested with IBM SecureWay firewall.

### **Security Dynamics SecurID token**

The authentication method from Security Dynamics includes a user ID and a SecurID token. When you log in remotely, you get your password from the SecurID token. The password changes every 60 seconds and is good for one-time use only. So, even if someone does intercept your password over the open network, the password is not valid for additional use.

## SecureWay Policy Director integration with firewall

The SecureWay Policy Director administers (writes to) the SecureWay Directory, which is IBM's implementation of the lightweight directory access protocol (LDAP). The firewall can access (reads from) the SecureWay Directory to authenticate firewall users of the following types of proxy services:

- ▶ FTP
- ▶ Telnet
- ▶ HTTP
- ▶ Socks

Some firewalls provide the facility to customize a user exit to support any other authentication mechanism. The IBM SecureWay firewall includes an application programming interface (API) to help you define your own authentication technique. And if you choose to authenticate users with passwords, the rules are robust. The firewalls apply extensive password rules to ensure that nontrivial passwords are used.

## DNS and mail gateways

Access to the domain name records of the secure network is of great assistance to intruders, because it gives them a list of hosts to attack. A subverted DNS server can also provide an access route for an intruder. So, the name server configured on the firewall is essential. From the external network, the name server on the firewall only knows itself and never gives out information on the internal IP network. From the internal network, this name server knows the Internet and is very useful for accessing any machine on the Internet by its name.

Mail is one of the primary reasons why an organization would want to access the Internet. Mail gateways control mail traversal through your network, allowing mail to flow securely inside and outside of your network. One of the important features of mail gateways can include domain name hiding for outgoing mail, which means hiding internal naming conventions and addresses from outside world so that mail appears to be coming from the firewall.

## Network address translation (NAT)

Originally NAT was developed as a solution to the IP depletion problem. The idea of NAT is based on the fact that only a small portion of the hosts in a private network are communicating with the outside world at any point of time. Each host is assigned a valid address from the official IP address pool only when it has to communicate with the outside world.

In the outbound direction, NAT converts the unregistered addresses into valid registered Internet addresses. In the inbound direction, NAT converts the registered Internet address back to the unregistered addresses.

Furthermore, by using NAT, addresses in the private network are hidden from the external world providing an additional level of security. However, NAT doesn't apply to the clients that communicate with internet using a proxy or Socks, because their addresses are not exposed and the TCP/IP connections are anyway broken at the firewall.

## Virtual Private Networks

A Virtual Private Network (VPN) is an extension of an enterprise's private intranet across a backbone network, which typically will be a public backbone such as the Internet. VPN allows the user to obscure the real data being sent between two private networks and also allows you to be assured of the identity of the session partners and the authenticity of the messages, that is, by creating a secure connection to protect the data while it is in transit over the backbone.

The VPN tunnel uses the open IPsec security standards to protect your data from modification or disclosure while it is travelling between firewalls. Your data will flow within a VPN tunnel, which can provide data origin authentication, confidentiality, and integrity checking on every packet. IPsec protocols can keep your data private, hiding it from any eavesdroppers on the public network. Packet filtering in the firewall can be used in conjunction with IPsec technologies to further protect your intranets from unwanted intrusions.

VPN tunnels can be established between pairs of firewalls or between the firewall and any other device (client, router, server, or firewall) that supports the latest open IPsec standards. Encryption support can include 3DES, DES, and CDMF. Authentication support includes HMAC-MD5 and HMAC-SHA.

## Log management

The log management utility is a very important feature of any firewall. Firewall logging should be both very detailed and precise. The firewall log should be able to capture all the important activities across the firewall, and it is very important that it should have the features like generating alerts based on various important criteria for organizational needs. The number of ways alerts can be generated include pager notification, email notification, and logging into some alert log file when a certain threshold set is reached. Some sample thresholds might include: a certain number of authentication failures within a given time, or the number frequent attempts on some deny policy/rule, etc. However, this again depends on one's own requirements. Finally, the firewall log management should provide the facility for proper log archiving and report generation.

## Firewalls in the market

Following are some of the firewall products currently in the market. You can check out the following URLs for more information about each firewall:

- ▶ IBM SecureWay firewall  
<http://www-3.ibm.com/software/security/firewall>
- ▶ Raptor firewall  
<http://www.symantec.com>
- ▶ Cisco PIX  
<http://www.cisco.com>
- ▶ Check Point firewall-1  
<http://www.checkpoint.com>
- ▶ Firewall Toolkit  
<http://www.fwtk.org/main.html>





# Abbreviations and acronyms

<b>ACL</b>	Access Control List	<b>ICMP</b>	Internet Control Message Protocol
<b>ACP</b>	Adapter Configuration Profile	<b>IETF</b>	Internet Engineering Task Force
<b>ADE</b>	Advanced Development Environment	<b>IKE</b>	Internet Key Exchange
<b>API</b>	Application Programming Interface	<b>INV</b>	Inventory
<b>ARM</b>	Application Response Measurement	<b>IOM</b>	Inter Object Messaging
<b>BDT</b>	Bulk Data Transfer	<b>IPX</b>	Internetwork Packet Exchange
<b>BOA</b>	Basic Object Adapter	<b>IR</b>	Install Repository (SIS)
<b>CORBA</b>	Common Object Request Broker Architecture	<b>ISO</b>	International Organization for Standardization
<b>CORP</b>	Corporate Network	<b>ISP</b>	Internet Service Provider
<b>DCE</b>	Distributed Computing Environment	<b>ITSO</b>	International Technical Support Organization
<b>DII</b>	Dynamic Invocation Interface	<b>LAN</b>	Local Area Network
<b>DM</b>	Distributed Monitoring	<b>LDAP</b>	Lightweight Directory Access Protocol
<b>DMZ</b>	Demilitarized Zone	<b>MDist</b>	Multiplexed Distribution
<b>DNS</b>	Domain Name Server	<b>MN</b>	Managed Node
<b>ECP</b>	Endpoint Communications Protocol	<b>NAT</b>	Network Address Translation
<b>EIF</b>	Event Integration Facility	<b>NFS</b>	Network File System
<b>EP</b>	Endpoint	<b>ORB</b>	Object Request Broker
<b>FTP</b>	File Transfer Protocol	<b>PAT</b>	Port Address Translation
<b>GEM</b>	Global Enterprise Manager	<b>RC</b>	Remote Control
<b>GUI</b>	Graphical User Interface	<b>RDBMS</b>	Relational Database Management System
<b>GW</b>	Gateway	<b>RFC</b>	Request for Comments
<b>HTML</b>	Hypertext Markup Language	<b>RIM</b>	RDBMS Interface Module
<b>HTTP</b>	Hypertext Transfer Protocol	<b>RMC</b>	Raptor Management Console
<b>IANA</b>	Internet Assigned Numbers Authority	<b>RPC</b>	Remote Procedure Call
<b>IBM</b>	International Business Machines Corporation	<b>SIS</b>	Software Installation Service

<b>SMB</b>	Server Message Block (Microsoft networking protocol)
<b>SNMP</b>	Simple Network Management Protocol
<b>SPX</b>	Sequenced Packet Exchange
<b>SSL</b>	Secure Sockets Layer
<b>SWD</b>	Software Distribution
<b>TACF</b>	Tivoli Access Control Facility
<b>TCP/IP</b>	Transmission Control Protocol/Internet Protocol
<b>TEC</b>	Tivoli Enterprise Console
<b>TFST</b>	Tivoli Firewall Security Toolbox
<b>TMA</b>	Tivoli Management Agent
<b>TME</b>	Tivoli Management Environment
<b>TMF</b>	Tivoli Management Framework
<b>TMR</b>	Tivoli Management Region
<b>TRIP</b>	Former acronym used for Tivoli Remote Execution Service
<b>TSD</b>	Tivoli Software Distribution
<b>UDP</b>	User Datagram Protocol
<b>VPN</b>	Virtual Private Network
<b>WAN</b>	Wide Area Network

# Related publications

The publications listed in this section are considered particularly suitable for a more detailed discussion of the topics covered in this redbook.

## IBM Redbooks

For information on ordering these publications, see “How to get IBM Redbooks” on page 200. Note that some of the documents referenced here may be available in softcopy only:

- ▶ *All About IBM Tivoli Configuration Manager*, SG24-6612
- ▶ *All About Tivoli Management Agents*, SG24-5134
- ▶ *Check Point FireWall-1 on AIX: A Cookbook for Stand-Alone and High Availability*, SG24-5492
- ▶ *Implementing Tivoli Remote Control in Large Enterprises*, SG24-5125
- ▶ *A Secure Way to Protect Your Network: IBM SecureWay Firewall for AIX Version 4.1*, SG24-5855
- ▶ *Tivoli Enterprise Internals and Problem Determination*, SG24-2034
- ▶ *Tivoli Enterprise Management Across Firewalls*, SG24-5510

## Other publications

These publications are also relevant as further information sources:

- ▶ *IBM Tivoli Remote Control Release Notes*, SC23-4844
- ▶ *IBM Tivoli Remote Control User's Guide*, SC23-4842
- ▶ *Firewall Security Toolbox User's Guide*, GC23-4826
- ▶ *Tivoli Management Framework Planning for Deployment Guide*, GC32-0803
- ▶ *TME 10 Enterprise Console Adapters Guide 3.7*
- ▶ *TME 10 Event Integration Facility User's Guide 3.7*
- ▶ Cheswick, et al, *Firewalls and Internet Security: Repelling the Wily Hacker*, Addison-Wesley, 1994, ISBN 0201633574
- ▶ Stevens, *TCP/IP Illustrated Volume I: The Protocols*, Addison-Wesley, 1993, ISBN 0201633469

- ▶ Zwicky, et al, *Building Internet Firewalls*, O'Reilly and Associates, Inc., 2000, ISBN 1565928717

## Online resources

These Web sites and URLs are also relevant as further information sources:

- ▶ IBM Tivoli Remote Control Product Information  
<http://www-3.ibm.com/software/tivoli/products/remote-control/>
- ▶ IBM SecureWay firewall  
<http://www-3.ibm.com/software/security/firewall>
- ▶ Raptor firewall  
<http://www.symantec.com>
- ▶ Cisco PIX  
<http://www.cisco.com>
- ▶ Check Point firewall-1  
<http://www.checkpoint.com>
- ▶ Firewall Toolkit  
<http://www.fwtk.org/main.html>

## How to get IBM Redbooks

You can search for, view, or download Redbooks, Redpapers, Hints and Tips, draft publications and Additional materials, as well as order hardcopy Redbooks or CD-ROMs, at this Web site:

[ibm.com/redbooks](http://ibm.com/redbooks)

# Index

## Numerics

3DES 194

## A

Authentication 190

AutoSocks 192

## B

bidirectional 61

bidirectional communication 12, 61

bidirectional connection 61

## C

CDMF 194

collection 6

communication ports 62

communication types

    bidirectional 61

    unidirectional 61

configuration files

    eproxy.cfg 12

    gwproxy.cfg 12

    rcproxy.cfg 12

## D

debug level 147

definition

    Controller Proxy 8

    RC Controller 7

    RC Gateway 8

    RC Policies 7

    RC Server 7

    RC Target 8

    RC Tool 7

    Target Proxy 8

DES 194

dispatcher 158

DNS & Mail Gateways 190

## E

endpoint 6

endpoint gateway 5

endpoint manager 5

Endpoint Proxy 176

endpoint proxy 5, 45

epmgrlog 146

epp.log 147, 163

eproxy.cfg 149

eqnrcmai.exe 153

Event Sink 176

EventSink.exe 181

## F

firewall configuration 73

firewall tables 73

firewall troubleshooting 171

## G

gatelog 145

Gateway Proxy 45, 176

gateway proxy 6

gwp.log 147, 163

gwproxy.cfg 149

## H

handshake 149

hardware requirements 76

HMAC-MD5 194

HMAC-SHA 194

HTTP 61

HTTP protocol 95

HUB-Spoke 21

HUB-Spoke architecture 13

HyperText Transfer Protocol 61

## I

ICA tags 171

Initiator 12

initiator 99

Internet Explorer 76

iptrace 171

is\_proxied\_ep method 20, 42

## J

Java xiv  
Java 2 SDK 77  
JRE 1.3 77

## K

keyboard control xv, 3  
keyword  
    Gateway Host 149  
kill processes 110

## L

lcmd.log 145  
Level 3 support 85  
Listener 12  
Log Management 190  
logical design 58

## M

managed node 5  
Methods  
    is\_proxied\_ep 20, 42  
    nd\_start\_controller 44, 55  
    nd\_start\_target 20  
methods for RC sessions 13  
multi-TMR 13

## N

NAT 193  
nd\_start\_controller method 44, 55  
nd\_start\_target method 20, 43, 46, 52, 54  
Netscape 76  
netstat command 110  
netstat -rn 172  
Network Address Translation 190  
network zone 5  
non-TME adapters 177

## O

Object DataBase 4  
odadmin 97  
odstat 18  
oservlog 146  
outsourcing 3

## P

Packet Filters 190  
Parent-Child 61  
Parent-Child hierarchy 10  
pcremote process 142  
peer-to-peer connection 16  
physical design 59  
Policies  
    rc\_def\_gw 32  
    rc\_def\_port 41  
    rc\_def\_ports 58  
    rc\_def\_proxy 107  
    Remote Control 7  
    RemoteControl 16  
policy region 6  
polling-interval 12  
problem determination  
    Endpoint 143  
    RC Proxies 151  
    TFST 147  
proxy  
    endpoint 5  
    gateway 6  
proxy communication  
    bidirectional 12  
    initiator 12  
    Listener 12  
    unidirectional 12  
Proxy Servers 190

## Q

Query 159

## R

RC data flow  
    multi TMR no firewall 21  
    RC gateway multi TMR 34  
    RC gateway single TMR 31  
    single TMR no firewall 14  
    StandAlone multi TMR 39  
    StandAlone single TMR 36  
    TFST multi TMR 50  
    TFST single TMR 45  
RC Proxy installation 101  
rc\_def\_encryption 58  
rc\_def\_gw policy 32  
rc\_def\_port policy 37, 41, 48  
rc\_def\_ports 58

- rc\_def\_ports policy 58
- rc\_def\_proxy 58, 107, 160
- rc\_def\_proxy policy 37, 40, 47, 52, 107
- rcproxy 109, 113
- rcproxy.cfg 156
- rcproxy.cfg file 37, 41, 48
- rcproxy.log 155–156
- rcproxy.route 106, 154
- rcproxy.route file 37, 41
- RCProxy-TFST 60
- Redbooks Web site 200
  - Contact us xvii
- reexec 146
- Relay 176
- relay 6
- relay.cfg 150
- relay.log 150
- remcon.ini 158
- remcon.ini file 151
- remcon.trc 154–155, 162
- Remote Control
  - Controller 7
  - Controller Proxy 8
  - Gateway 8, 31
  - logical design 58
  - physical design 59
  - policies 58
  - Server 7
  - Target 8
  - Target Proxy 8
  - Tool 7
- Remote Control Polices 16
- Remote Control Policies 7
- Remote Control sessions 13
- remote\_control method 19
- reverse resolution 153
- Runtime Java 77

## S

- SDK Java 77
- SecurID 192
- Security Officer 61
- single-TMR 13
- Socks 190
- Socks-aware 192
- software requirements 77
- starting sessions 13
- Stateful packet 191

- subverted DNS 193
- support applications requirements 76

## T

- TCP/IP ports list 62
- Tell reply 149, 153
- Tivoli adapters 179
- Tivoli administrators 6
- Tivoli collection 6
- Tivoli Commands
  - EventSink.exe 181
  - odadmin 97
  - rcproxy 109, 113
  - TivoliRelay.exe 127
  - wep 160, 163
  - wgateway 98
  - wgetpolm 107
  - wping 146
  - wputpolm 107
- Tivoli object database 4
- Tivoli resources 97
  - Administrator 97
  - AdministratorCollection 97
  - Endpoint 97
  - EndpointManager 97
  - ManagedNode 97
  - PolicyRegion 97
  - ProfileManager 97
- Tivoli Top-Down hierarchy 10
- TivoliRelay.exe 127
- TMA 6
- TMR HUB 21
- TMR server 4
- TMR Spoke 96
- Tunnel VPN 194

## U

- unidirectional communication 12, 61
- unidirectional connection 99

## V

- Virtual Private Networks 190
- VPN tunnel 194

## W

- wep 160, 163
- wgateway 98

wgetpolm 107  
Who request 149, 153  
wping 146  
wputpolm 107  
wtrace 18





## Implementing IBM Tivoli Remote Control Across Firewalls

(0.2" spine)  
0.17" x 0.473"  
90 x 249 pages







**Redbooks**

# Implementing IBM Tivoli Remote Control Across Firewalls

**Achieve Remote Control without sacrificing security**

**Guide for TCP/IP ports used and troubleshooting**

**Set up a secure Remote Control environment based on realistic scenarios**

The primary objective of this IBM Redbook is to provide concepts, recommendations, and techniques when planning and implementing IBM Tivoli Remote Control 3.8 in an environment that involves firewalls.

This book can be used as a reference to guide you during the planning, installation, and configuration phases. It focuses on how to effectively deploy IBM Tivoli Remote Control 3.8 across firewalls in a way that quickly generates real business value for customers.

This book will prove invaluable to Tivoli systems administrators, firewall administrators, and security policy administrators, when planning, designing, and operating a systems management environment involving the need to have workstations and servers being remotely controlled, independent of their location in the network.

**INTERNATIONAL  
TECHNICAL  
SUPPORT  
ORGANIZATION**

**BUILDING TECHNICAL  
INFORMATION BASED ON  
PRACTICAL EXPERIENCE**

IBM Redbooks are developed by the IBM International Technical Support Organization. Experts from IBM, Customers and Partners from around the world create timely technical information based on realistic scenarios. Specific recommendations are provided to help you implement IT solutions more effectively in your environment.

**For more information:  
[ibm.com/redbooks](http://ibm.com/redbooks)**

SG24-6944-00

ISBN 0738453404

## Free Manuals Download Website

<http://myh66.com>

<http://usermanuals.us>

<http://www.somanuals.com>

<http://www.4manuals.cc>

<http://www.manual-lib.com>

<http://www.404manual.com>

<http://www.luxmanual.com>

<http://aubethermostatmanual.com>

Golf course search by state

<http://golfingnear.com>

Email search by domain

<http://emailbydomain.com>

Auto manuals search

<http://auto.somanuals.com>

TV manuals search

<http://tv.somanuals.com>