

Thank you for purchasing this Factory Service Manual CD/DVD from servicemanuals4u.com.

Please check out our eBay auctions for more great deals on Factory Service Manuals:

[servicemanuals4u](http://servicemanuals4u.com)

IBM Mobile Systems

S82G-1502-03

**Hardware Maintenance Manual
Volume 2: ThinkPad Computers**

April 1995

**We Want Your Comments!
(Please see page 491)**

This Manual Supports:

- ThinkPad 340x (2610)
- ThinkPad 355x (2619)
- ThinkPad 360x (2620)
- ThinkPad 370x (9545)
- ThinkPad 700x (9552)
- ThinkPad 701x (2630)
- ThinkPad 720x (9552)
- ThinkPad 750x (9545)
- ThinkPad 755x (9545)

IBM Mobile Systems

S82G-1502-03

**Hardware Maintenance Manual
Volume 2: ThinkPad Computers**

April 1995

**We Want Your Comments!
(Please see page 491)**



Note

Before using this information and the product it supports, be sure to read the general information under "Notices" on page 497.

Fourth Edition (April 1995)

The following paragraph does not apply to the United Kingdom or any country where such provisions are inconsistent with local law: INTERNATIONAL BUSINESS MACHINES CORPORATION PROVIDES THIS PUBLICATION "AS IS" WITHOUT WARRANTY OF ANY KIND, EITHER EXPRESS OR IMPLIED, INCLUDING, BUT NOT LIMITED TO, THE IMPLIED WARRANTIES OF MERCHANTABILITY OR FITNESS FOR A PARTICULAR PURPOSE. Some states do not allow disclaimer of express or implied warranties in certain transactions, therefore, this statement may not apply to you.

This publication could include technical inaccuracies or typographical errors. Changes are periodically made to the information herein; these changes will be incorporated in new editions of the publication. IBM may make improvements and/or changes in the product(s) and/or the program(s) described in this publication at any time.

This publication was developed for products and services offered in the United States of America. IBM may not offer the products, services, or features discussed in this document in other countries, and the information is subject to change without notice. Consult your local IBM representative for information on the products, services, and features available in your area.

Requests for technical information about IBM products should be made to your IBM reseller or IBM marketing representative.

© Copyright International Business Machines Corporation 1995. All rights reserved.

Note to U.S. Government users—Documentation related to Restricted rights—Use, duplication, or disclosure is subject to restrictions set forth in GSA ADP Schedule Contract with IBM Corp.

About This Manual

This manual contains service and reference information for IBM* ThinkPad* computer products. Use this manual along with the advanced diagnostic tests to troubleshoot problems effectively.

The manual is divided into sections as follows:

- The Introduction section provides general information, guidelines, and safety information required to service computers.
- The majority of the manual consists of product-specific sections that include service, reference, and product-specific parts information.
- The Common Devices Checkout section provides procedures for testing the devices that are commonly attached to ThinkPad computers.
- The Miscellaneous Information section contains information about acronyms, abbreviations, terms, and a telephone number listing.

Important

This manual is intended for trained servicers who are familiar with ThinkPad products. Use this manual along with the advanced diagnostic tests to troubleshoot problems effectively.

Before servicing an IBM mobile product, be sure to review the safety information under “Safety Notices (Multi-lingual Translations)” on page 7 and “Safety Information” on page 14.

* Trademark of the IBM Corporation.

Related Publications

The following mobile product publications are available through IBM or your IBM Authorized Dealer.

Publication	Part, Form Number
Mobile Systems HMM Volume 1: Laptop, Notebook, Portable, and Thinkpad Computers	30H2356, S82G-1501-01
ThinkPad 700 (9552) HMS	42G2016, S42G-2016
ThinkPad 700 (9552) HMR	42G2015, S42G-2015
ThinkPad 700C (9552) HMS	42G2022, S42G-2022
ThinkPad 700C (9552) HMR	42G2021, S42G-2021
ThinkPad 720/720C (9552) HMS	61G1193, S61G-1193
ThinkPad 720/720C (9552) HMR	61G1187, S61G-1187
ThinkPad 730T (2524) HMM	82G5497, S82G-5497
ThinkPad Exp. Crtg. (3550) HMS	42G2338, S42G-2338
ThinkPad Exp. Crtg. (3550) HMR	42G2339, S42G-2339
PS/2 FaxConcentrator* HMS	15F2262, S15F-2262
PS/2 FaxConcentrator HMR	84F8541, S84F-8541
PS/2 Comm. Cartridge I HMS	10G5993, S10G-5993
PS/2 Comm. Cartridge I HMR	10G5992, S10G-5992
IBM High Speed Internal, PCMCIA Data/Fax Modems	61G1556, S61G-1556

Obsolete Publications

This manual obsoletes the following publication:

Publication	Part, Form Number
Mobile Systems HMM Volume 2: ThinkPad Computers	82G1502, S82G1502 19H1080, S82G1502

Related Diskettes

The following diskettes are available through IBM or your IBM Authorized Dealer.

Diskette	Part, Form Number
ThinkPad 300 (2615) Advanced Diagnostics	33G9361, S33G-9361
ThinkPad 350, 350C, 425, 425C (2618) Advanced Diagnostics Diskette	A211000, GA21-1000
ThinkPad 500 (2603) Adv. Diagnostics Diskette	71G3702, S71G-3702
ThinkPad 510 (2604) Adv. Diagnostics Diskette	83G8095, S83G-8095
ThinkPad 700 (9552) Reference Diskette	42G2017, S42G-2017
ThinkPad 700C (9552) Reference Diskette	42G2023, S42G-2023
ThinkPad 720/720C (9552) Reference Diskette	61G1194, S61G-1194
ThinkPad 750Ce (9545) Hardware Maintenance (for all Models 355x, 360x, 750x, and 755x)	82G3891, S82G-3891
ThinkPad Dock I (3545)	71G4140, S71G-4140
Docking Station (3550)	42G2428, S42G-2428
Data/Fax Modem	61G1556, S61G-1556
FaxConcentrator/A	84F8540, S84F-8540

* Trademark of the IBM Corporation.

Contents

Introduction	1
Portable Computer Descriptions	2
Drive and Diskette Compatibility Matrix	4
Important Service Information	5
Safety Notices (Multi-lingual Translations)	7
Safety Information	14
Laser Compliance Statement	19
Screw Size Chart	20
ThinkPad 340x (IBM 2610)	23
General Checkout	25
Symptom-to-FRU Index	34
Related Service Procedures	43
Product Overview	48
FRU Removals and Replacements	49
Locations	59
Parts Listing	62
ThinkPad 700, 700C, 720, 720C (9552)	67
General Checkout	68
Symptom-to-FRU Index	82
Related Service Procedures	94
Product Overview	102
FRU Removals and Replacements	104
Locations	110
Parts Listing (700)	115
Parts Listing (720, 720C)	118
ThinkPad 701C/701CS (2630)	125
Checkout Guide	127
Symptom-to-FRU Index	141
Related Service Procedures	154
Product Overview	159
FRU Removals and Replacements	161
Locations	181
Parts Listing	190
ThinkPad 355x, 360x, 370C, 750x, 755C, 755Cs	195
Read This First	197
General Checkout	200
Symptom-to-FRU Index	216
Related Service Procedures	228
Product Overview	232
FRU Removals and Replacements	236
Removals Models 355x, 360x	237
Removals Models 370C, 750x, 755C, 755Cs	261
Locations	289
Parts Listing	296
ThinkPad 755CD, 755CDV (9545)	315
General Checkout	317

Symptom-to-FRU Index	331
Related Service Procedures	344
Product Overview	349
FRU Removals and Replacements	350
Locations	381
Parts Listing	383
ThinkPad 755CE, 755CSE, 755CV, 755CX (9545)	391
General Checkout	393
Symptom-to-FRU Index	408
Related Service Procedures	420
Product Overview	424
FRU Removals and Replacements	426
Locations	458
Parts Listing	460
Common Devices Checkout	469
External Diskette Drive Test	470
External Display Self-Test	470
External Keyboard/Auxiliary Input Device Checkout	471
Fax/Modem Checkout	472
Printer Checkout	474
Port Replicator Checkout	475
TrackPoint II Checkout	476
TV Tuner	477
Common Parts Listing	483
Miscellaneous Information	489
Acronyms, Abbreviations and Terms	489
Send Us Your Comments!	491
Do You Need Technical References?	492
Problem Determination Tips	493
Phone Numbers, U.S. and Canada	494
Notices	497

Introduction

Portable Computer Descriptions	2
Drive and Diskette Compatibility Matrix	4
Important Service Information	5
How to Use Error Messages	6
How to Read POST Error Messages	6
Safety Notices (Multi-lingual Translations)	7
Safety Information	14
General Safety	14
Electrical Safety	15
Safety Inspection Guide	16
Handling Electrostatic Discharge-Sensitive Devices	18
Grounding Requirements	18
Laser Compliance Statement	19
Screw Size Chart	20

Portable Computer Descriptions

All models in the following table have VGA video. Models N51, CL57, and P70/75 and Thinkpads 700x and 720x are Micro Channel* systems. All others are AT* bus systems.

Model	Type	Processor	Memory	Hrd Dsk
Model L40SX	8543-044	386SX-20	2M/18M	60M
Model N45 SL	2614-065	386SL-25	2M/8M	80M
	2614-067	386SL-25	2M/8M	120M
Model N51 SLC	8551-025	386SLC-16	2M/10M	80M
Model N51 SX	8551-033	386SX-16	2M/10M	40M
Model CL57 SX	8554-045	386SX-20	2M/16M	80M
Model P70 386	8573-031	80386-16	2M/8M	30M
	8573-061	80386-20	2M/8M	60M
	8573-121	80386-20	2M/8M	120M
Model P75 486	8573-161	80486-33	8M/16M	160M
	8573-401	80486-33	8M/16M	400M
ThinkPad 300	2615-065	386SL-25	4M/12M	80M
	2615-067	386SL-25	4M/12M	120M
ThinkPad 340	2610	486SLC2-50	4M/12M	125M
ThinkPad 350	2618-AOE	486SL-25	4M/20M	85M
	2618-JOA	486SL-25	4M/20M	125M
	2618-LOA	486SL-25	4M/20M	250M
ThinkPad 350C	2618-NOA	486SL-25	4M/20M	125M
	2618-POA	486SL-25	4M/20M	250M
ThinkPad 355	2619	486SX-33	4M/16M	125M
ThinkPad 355C	2619	486SX-33	4M/16M	125M
	2619	486SX-33	4M/16M	250M
ThinkPad 355Cs	2619	486SX-33	2M/16M	170M
	2619	486SX-33	2M/16M	250M
ThinkPad 360	2620	486SX-33	4M/16M	170M
	2620	486SX-33	4M/16M	340M
ThinkPad 360C	2620	486SX-33	4M/16M	170M
	2620	486SX-33	4M/16M	340M
ThinkPad 360Cs	2620	486SX-33	4M/16M	170M
	2620	486SX-33	4M/16M	340M
ThinkPad 360Ce	2620	486DX2-50/25	4M/16M	170M
	2620	486DX2-50/25	4M/16M	340M
	2620	486DX2-50/25	4M/16M	540M
ThinkPad 360Cse	2620	486DX2-50/25	4M/16M	170M
	2620	486DX2-50/25	4M/16M	340M
	2620	486DX2-50/25	4M/16M	540M
ThinkPad 360P	2620	486SX-33	4M/16M	170M
	2620	486SX-33	4M/16M	340M
ThinkPad 370C	9545	486DX4-75/25	4M/32M	340M
	9545	486DX4-75/25	4M/32M	540M
	9545	486DX4-75/33	4M/32M	810M
ThinkPad 500	2603-081	486SLC2-50/254M/12M		80M
	2603-171	486SLC2-50/254M/12M		170M
ThinkPad 510	2604	486BLC2-50/254M/20M		200M
ThinkPad 700	9552-300	486SLC-25	4M/16M	80M
	9552-301	486SLC-25	4M/16M	120M
ThinkPad 700C	9552-30B	486SLC-25	4M/16M	120M

C	Color	T	Tablet
M	Megabyte	TPF	ThinkPad File
P	Pen		

* Trademark of the IBM Corporation.

Model	Type	Processor	Memory	Hrd Dsk
ThinkPad 701C	2630	486DX2-25/50	4M/32M	360MB
	2630	486DX2-25/50	4M/32M	540MB
	2630	486DX4-25/75	8M/32M	360MB
	2630	486DX4-25/75	8M/32M	540MB
ThinkPad 701Cs	2630	486DX2-25/50	4M/32M	360MB
	2630	486DX2-25/50	4M/32M	540MB
	2630	486DX4-25/75	8M/32M	360MB
ThinkPad 710T	2523-09Y	486SLC2-25	4M/12M	TPF
	2523-302	486SLC2-25	4M/12M	60M
	2523-303	486SLC2-25	4M/12M	60M
ThinkPad 720	9552-307	486SLC-25/50	4M/16M	120M
	9552-308	486SLC-25/50	4M/16M	160M
ThinkPad 720C	9552-30J	486SLC-25/50	4M/16M	160M
ThinkPad 730T	2524	486SLC2-25	4M/12M	0M
	2524	486SLC2-25	4M/12M	60M
ThinkPad 750	9545-006	486SL-33	4M/20M	170M
	9545-008	486SL-33	4M/20M	340M
ThinkPad 750C	9545-306	486SL-33	4M/20M	170M
	9545-308	486SL-33	4M/20M	340M
ThinkPad 750Ce	9545	P24S-50/25	4M/20M	340M
ThinkPad 750Cs	9545	486SL-33	4M/20M	170M
	9545	486SL-33	4M/20M	340M
	9545-40C	486SL-33	4M/20M	170M
ThinkPad 750P	9545-40E	486SL-33	4M/20M	340M
	9545-40E	486SL-33	4M/20M	340M
ThinkPad 755C	9545	486DX4-50/25	4M/32M	170M
	9545	486DX4-50/25	4M/32M	340M
	9545	486DX4-50/25	4M/32M	540M
	9545	486DX4-75/25	4M/32M	170M
	9545	486DX4-75/25	4M/32M	340M
	9545	486DX4-75/25	4M/32M	540M
ThinkPad 755CD	9545	486DX4-100/338M/32M		540M
	9545	486DX4-100/338M/32M		810M
ThinkPad 755CDV	9545	486DX4-100/338M/32M		540M
	9545	486DX4-100/338M/32M		810M
ThinkPad 755Ce	9545	486DX4-100/338M/32M		340M
	9545	486DX4-100/338M/32M		540M
	9545	486DX4-100/338M/32M		810M
ThinkPad 755Cs	9545	486DX4-50/25	8M/32M	170M
	9545	486DX4-50/25	8M/32M	340M
	9545	486DX4-50/25	8M/32M	540M
	9545	486DX4-75/25	8M/32M	170M
	9545	486DX4-75/25	8M/32M	340M
	9545	486DX4-75/25	8M/32M	540M
ThinkPad 755Cse	9545	486DX4-100/338M/32M		340M
	9545	486DX4-100/338M/32M		540M
	9545	486DX4-100/338M/32M		810M
ThinkPad 755CV	9545	486DX4-100/338M/32M		540M
	9545	486DX4-100/338M/32M		810M
ThinkPad 755CV	9545	486DX4-100/338M/32M		540M
	9545	486DX4-100/338M/32M		810M

C	Color	T	Tablet
M	Megabyte	TPF	ThinkPad File
P	Pen		

Drive and Diskette Compatibility Matrix

The following table provides identification information for 3.5-inch drives.

Diskette Drive	Identifying Mark
3.5-Inch - 1.44MB	1.44 on the eject button
3.5-Inch - 2.88MB	2.88 on the eject button

The following table provides compatibility information for 3.5-inch diskettes and 3.5-inch diskette drives.

Diskette Capacity	1.44MB Drive	2.88MB Drive
1.0MB	Read/Write	Read/Write
2.0MB	Read/Write	Read/Write
4.0MB	Not Compatible	Read/Write

The following table provides identification information for 5.25-inch diskette drives.

Diskette Drive	Identifying Mark
5.25-Inch - 360KB (External)	Asterisk on bezel
5.25-Inch - 1.2MB (Internal)	1.2 on the eject button

The following table provides compatibility information for 5.25-inch diskettes and 5.25-inch diskette drives.

Diskette Capacity	360KB Drive	1.2MB Drive
360KB	Read/Write	Read/Write
1.2MB	Not Compatible	Read/Write

Note: A 360KB diskette written to or formatted on a 1.2MB drive can be read reliably only on a 1.2MB drive.

Important Service Information

Important

Diskette fixes are customer installable. The diskette fixes are located on the PC Company Bulletin Board Service (BBS). The direct phone line for modem connection is 919-557-0001 or tieline 255-0001.

Advise customers to contact the PC Company HelpCenter at 800-772-2227 if they need assistance in obtaining or installing any diskette fixes.

Customers in Canada should call IBM HelpPC at 800-565-3344 for assistance or down-load information. The Canadian BBS phone numbers are:

Montreal 514-938-3022

Toronto 905-316-4255

Vancouver 604-664-6464

Winnipeg 204-934-2735

FRU Replacement Strategy

Before Replacing Parts

Ensure that all diskette fixes are installed prior to replacing any FRUs listed in this manual.

Use the following strategy to prevent unnecessary FRU replacement and service expense:

- **If you are instructed to replace a FRU and that does not correct the problem, reinstall the original FRU before you continue.**
- Some computers have both a processor board and a system board. If you are instructed to replace either the processor board or the system board, and the first board that you replaced does not correct the problem, reinstall the original board, then replace the other (processor or system) board.
- If an adapter or device consists of more than one FRU, an error code may be caused by any of the FRUs. Before replacing the adapter or device, remove the FRUs, one by one, to see if the symptoms change. Replace only the FRU that changed the symptoms.

Warning: A customized setup configuration (other than default settings) may exist on the computer you are servicing. Running Automatic Configuration may alter those settings. Note the current configuration settings (using the View Configuration option) and verify that the settings are in place when service is complete.

The advanced diagnostic tests are intended to test *only* IBM products. Non-IBM products or modified options can give false errors and invalid responses.

Hard Disk Drive Replacement Strategy:

Always try to run a low-level format before replacing a hard disk drive.

Warning: The drive startup sequence in the computer you are servicing might have been changed. Be extremely careful during write operations such as copying, saving, or formatting. Data or programs can be overwritten if you select an incorrect drive.

How to Use Error Messages

Use the error codes displayed on the screen to diagnose failures. If more than one error code is displayed, begin the diagnosis with the first error code. The cause of the first error code can result in false error codes being displayed. If no error code is displayed, see if the error symptom is listed in the Symptom-to-FRU Index for the computer you are servicing.

How to Read POST Error Messages

POST error messages are displayed on the screen as three, four, five, or eight digits. The error messages that can be displayed as shorter POST messages are highlighted in this index. Some digits will represent different information for SCSI errors versus non-SCSI errors.

The following example shows which digits display the shorter POST error messages and also defines the SCSI information in an eight-digit error message.

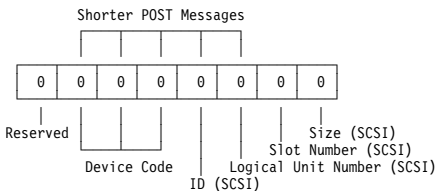

All SCSI devices are set to a different SCSI ID. Duplicate SCSI ID settings can generate a false error message. Use the SCSI ID to determine whether the error message is coming from an internal or an external device.

Safety Notices (Multi-lingual Translations)

In this manual, safety notices appear in English with a page number reference to the appropriate multi-lingual, translated safety notice found in this section.

The following safety notices are provided in English, French, German, Italian, and Spanish languages.

Safety Notice 1

Before the computer is powered-on after FRU replacement, make sure all screws, springs, or other small parts are in place and are not left loose inside the computer. Verify this by shaking the computer and listening for rattling sounds. Metallic parts or metal flakes can cause electrical shorts.

Avant de remettre l'ordinateur sous tension après remplacement d'une unité en clientèle, vérifiez que tous les ressorts, vis et autres pièces sont bien en place et bien fixées. Pour ce faire, secouez l'unité et assurez-vous qu'aucun bruit suspect ne se produit. Des pièces métalliques ou des copeaux de métal pourraient causer un court-circuit.

Bevor nach einem FRU-Austausch der Computer wieder angeschlossen wird, muß sichergestellt werden, daß keine Schrauben, Federn oder andere Kleinteile fehlen oder im Gehäuse vergessen wurden. Der Computer muß geschüttelt und auf Klappergeräusche geprüft werden. Metallteile oder -splitter können Kurzschlüsse erzeugen.

Prima di accendere l'elaboratore dopo che é stata effettuata la sostituzione di una FRU, accertarsi che tutte le viti, le molle e tutte le altri parti di piccole dimensioni siano nella corretta posizione e non siano sparse all'interno dell'elaboratore. Verificare ciò scuotendo l'elaboratore e prestando attenzione ad eventuali rumori; eventuali parti o pezzetti metallici possono provocare cortocircuiti pericolosi.

Antes de encender el sistema despues de sustituir una FRU, compruebe que todos los tornillos, muelles y demás piezas pequeñas se encuentran en su sitio y no se encuentran sueltas dentro del sistema. Compruébelo agitando el sistema y escuchando los posibles ruidos que provocarían. Las piezas metálicas pueden causar cortocircuitos eléctricos.

Safety Notice 2

Some standby batteries contain a small amount of nickel and cadmium. Do not disassemble it, recharge it, throw it into fire or water, or short-circuit it. Dispose of the battery as required by local ordinances or regulations. Use only the battery in the appropriate parts listing. Use of an incorrect battery can result in ignition or explosion of the battery.

Certaines batteries de secours contiennent du nickel et du cadmium. Ne les démontez pas, ne les rechargez pas, ne les exposez ni au feu ni à l'eau. Ne les mettez pas en court-circuit. Pour les mettre au rebut, conformez-vous à la réglementation en vigueur. Lorsque vous remplacez la pile de sauvegarde ou celle de l'horloge temps réel, veillez à n'utiliser que les modèles cités dans la liste de pièces détachées adéquate. Une batterie ou une pile inappropriée risque de prendre feu ou d'exploser.

Die Bereitschaftsbatterie, die sich unter dem Diskettenlaufwerk befindet, kann geringe Mengen Nickel und Cadmium enthalten. Sie darf nur durch die Verkaufsstelle oder den IBM Kundendienst ausgetauscht werden. Sie darf nicht zerlegt, wiederaufgeladen, kurzgeschlossen, oder Feuer oder Wasser ausgesetzt werden. Die Batterie kann schwere Verbrennungen oder Verätzungen verursachen. Bei der Entsorgung die örtlichen Bestimmungen für Sondermüll beachten. Beim Ersetzen der Bereitschafts- oder Systembatterie nur Batterien des Typs verwenden, der in der Ersatzteilliste aufgeführt ist. Der Einsatz falscher Batterien kann zu Entzündung oder Explosion führen.

Alcune batterie di riserva contengono una piccola quantità di nichel e cadmio. Non smontarle, ricaricarle, gettarle nel fuoco o nell'acqua né cortocircuitarle. Smaltirle secondo la normativa in vigore (DPR 915/82, successive disposizioni e disposizioni locali). Quando si sostituisce la batteria dell'RTC (real time clock) o la batteria di supporto, utilizzare soltanto i tipi inseriti nell'appropriato Catalogo parti. L'impiego di una batteria non adatta potrebbe determinare l'incendio o l'esplosione della batteria stessa.

Algunas baterías de reserva contienen una pequeña cantidad de níquel y cadmio. No las desmonte, ni recargue, ni las eche al fuego o al agua ni las cortocircuite. Deséchelas tal como dispone la normativa local. Utilice sólo baterías que se encuentren en la lista de piezas. La utilización de una batería no apropiada puede provocar la ignición o explosión de la misma.

Safety Notice 3

The battery pack contains small amounts of nickel. Do not disassemble it, throw it into fire or water, or short-circuit it. Dispose of the battery pack as required by local ordinances or regulations. Use only the battery in the appropriate parts listing when replacing the battery pack. Use of an incorrect battery can result in ignition or explosion of the battery.

La batterie contient du nickel. Ne la démontez pas, ne l'exposez ni au feu ni à l'eau. Ne la mettez pas en court-circuit. Pour la mettre au rebut, conformez-vous à la réglementation en vigueur. Lorsque vous remplacez la batterie, veillez à n'utiliser que les modèles cités dans la liste de pièces détachées adéquate. En effet, une batterie inappropriée risque de prendre feu ou d'exploser.

Akkus enthalten geringe Mengen von Nickel. Sie dürfen nicht zerlegt, wiederaufgeladen, kurzgeschlossen, oder Feuer oder Wasser ausgesetzt werden. Bei der Entsorgung die örtlichen Bestimmungen für Sondermüll beachten. Beim Ersetzen der Batterie nur Batterien des Typs verwenden, der in der Ersatzteilliste aufgeführt ist. Der Einsatz falscher Batterien kann zu Entzündung oder Explosion führen.

La batteria contiene piccole quantità di nichel. Non smontarla, gettarla nel fuoco o nell'acqua né cortocircuitarla. Smaltirla secondo la normativa in vigore (DPR 915/82, successive disposizioni e disposizioni locali). Quando si sostituisce la batteria, utilizzare soltanto i tipi inseriti nell'appropriato Catalogo parti. L'impiego di una batteria non adatta potrebbe determinare l'incendio o l'esplosione della batteria stessa.

Las baterías contienen pequeñas cantidades de níquel. No las desmonte, ni recargue, ni las eche al fuego o al agua ni las cortocircuite. Deséchelas tal como dispone la normativa local. Utilice sólo baterías que se encuentren en la lista de piezas al sustituir la batería. La utilización de una batería no apropiada puede provocar la ignición o explosión de la misma.

Safety Notice 4

The lithium battery can cause a fire, explosion, or severe burn. Do not recharge it, remove its polarized connector, disassemble it, heat it above 100°C (212°F), incinerate it, or expose its cell contents to water. Dispose of the battery as required by local ordinances or regulations. Use only the battery in the appropriate parts listing. Use of an incorrect battery can result in ignition or explosion of the battery.

La pile de sauvegarde contient du lithium. Elle présente des risques d'incendie, d'explosion ou de brûlures graves. Ne la rechargez pas, ne retirez pas son connecteur polarisé et ne la démontez pas. Ne l'exposez pas à une température supérieure à 100°C, ne la faites pas brûler et n'en exposez pas le contenu à l'eau. Mettez la pile au rebut conformément à la réglementation en vigueur. Une pile inappropriée risque de prendre feu ou d'exploser.

Die Systematterie ist eine Lithiumatterie. Sie kann sich entzünden, explodieren oder schwere Verbrennungen hervorrufen. Batterien dieses Typs dürfen nicht aufgeladen, zerlegt, über 100 C erhitzt oder verbrannt werden. Auch darf ihr Inhalt nicht mit Wasser in Verbindung gebracht oder der zur richtigen Polung angebrachte Verbindungsstecker entfernt werden. Bei der Entsorgung die örtlichen Bestimmungen für Sondermüll beachten. Beim Ersetzen der Batterie nur Batterien des Typs verwenden, der in der Ersatzteilliste aufgeführt ist. Der Einsatz falscher Batterien kann zu Entzündung oder Explosion führen.

La batteria di supporto è una batteria al litio e può incendiarsi, esplodere o procurare gravi ustioni. Evitare di ricaricarla, smontarne il connettore polarizzato, smontarla, riscaldarla ad una temperatura superiore ai 100 gradi centigradi, incendiarla o gettarla in acqua. Smaltirla secondo la normativa in vigore (DPR 915/82, successive disposizioni e disposizioni locali). L'impiego di una batteria non adatta potrebbe determinare l'incendio o l'esplosione della batteria stessa.

La batería de repuesto es una batería de litio y puede provocar incendios, explosiones o quemaduras graves. No la recargue, ni quite el conector polarizado, ni la desmonte, ni caliente por encima de los 100°C (212°F), ni la incinere ni exponga el contenido de sus celdas al agua. Deséchela tal como dispone la normativa local.

Safety Notice 5

If the LCD breaks and the fluid from inside the LCD gets into your eyes or on your hands, immediately wash the affected areas with water for at least 15 minutes. Seek medical care if any symptoms from the fluid are present after washing.

Si le panneau d'affichage à cristaux liquides se brise et que vous recevez dans les yeux ou sur les mains une partie du fluide, rincez-les abondamment pendant au moins quinze minutes. Consultez un médecin si des symptômes persistent après le lavage.

Die Leuchtstoffröhre im LCD-Bildschirm enthält Quecksilber. Bei der Entsorgung die örtlichen Bestimmungen für Sondermüll beachten. Der LCD-Bildschirm besteht aus Glas und kann zerbrechen, wenn er unsachgemäß behandelt wird oder der Computer auf den Boden fällt. Wenn der Bildschirm beschädigt ist und die darin befindliche Flüssigkeit in Kontakt mit Haut und Augen gerät, sollten die betroffenen Stellen mindestens 15 Minuten mit Wasser abgespült und bei Beschwerden anschließend ein Arzt aufgesucht werden.

Nel caso che caso l'LCD si dovesse rompere ed il liquido in esso contenuto entrasse in contatto con gli occhi o le mani, lavare immediatamente le parti interessate con acqua corrente per almeno 15 minuti; poi consultare un medico se i sintomi dovessero permanere.

Si la LCD se rompe y el fluido de su interior entra en contacto con sus ojos o sus manos, lave inmediatamente las áreas afectadas con agua durante 15 minutos como mínimo. Obtenga atención medica si se presenta algún síntoma del fluido despues de lavarse.

Safety Notice 6

To avoid shock, do not remove the plastic cover that surrounds the lower portion of the inverter card.

Afin d'éviter tout risque de choc électrique, ne retirez pas le cache en plastique protégeant la partie inférieure de la carte d'alimentation.

Aus Sicherheitsgründen die Kunststoffabdeckung, die den unteren Teil der Spannungswandlerplatine umgibt, nicht entfernen.

Per evitare scosse elettriche, non rimuovere la copertura in plastica che avvolge la parte inferiore della scheda invertitore.

Para evitar descargas, no quite la cubierta de plástico que rodea la parte baja de la tarjeta invertida.

Safety Notice 7

Though main batteries have low voltage, a shorted or grounded battery can produce enough current to burn combustible materials or personnel.

Bien que le voltage des batteries principales soit peu élevé, le court-circuit ou la mise à la masse d'une batterie peut produire suffisamment de courant pour brûler des matériaux combustibles ou causer des brûlures corporelles graves.

Obwohl Hauptbatterien eine niedrige Spannung haben, können sie doch bei Kurzschluß oder Erdung genug Strom abgeben, um brennbare Materialien zu entzünden oder Verletzungen bei Personen hervorzurufen.

Sebbene le batterie di alimentazione siano a basso voltaggio, una batteria in corto circuito o a massa può fornire corrente sufficiente da bruciare materiali combustibili o provocare ustioni ai tecnici di manutenzione.

Aunque las baterías principales tienen un voltaje bajo, una batería cortocircuitada o con contacto a tierra puede producir la corriente suficiente como para quemar material combustible o provocar quemaduras en el personal.

Safety Notice 8

Before removing any FRU, power-off the computer, unplug all power cords from electrical outlets, remove the battery pack, then disconnect any interconnecting cables.

Avant de retirer une unité remplaçable en clientèle, mettez le système hors tension, débranchez tous les cordons d'alimentation des socles de prise de courant, retirez la batterie et déconnectez tous les cordons d'interface.

Die Stromzufuhr muß abgeschaltet, alle Stromkabel aus der Steckdose gezogen, der Akku entfernt und alle Verbindungskabel abgenommen sein, bevor eine FRU entfernt wird.

Prima di rimuovere qualsiasi FRU, spegnere il sistema, scollegare dalle prese elettriche tutti i cavi di alimentazione, rimuovere la batteria e poi scollegare i cavi di interconnessione.

Antes de quitar una FRU, apague el sistema, desenchufe todos los cables de las tomas de corriente eléctrica, quite la batería y, a continuación, desconecte cualquier cable de conexión entre dispositivos.

Safety Information

The following section contains the safety information that you need to be familiar with before servicing an IBM mobile computer.

General Safety

Follow these rules to ensure general safety:

- Observe good housekeeping in the area of the machines during and after maintenance.
- When lifting any heavy object:
 1. Ensure you can stand safely without slipping.
 2. Distribute the weight of the object equally between your feet.
 3. Use a slow lifting force. Never move suddenly or twist when you attempt to lift.
 4. Lift by standing or by pushing up with your leg muscles; this action removes the strain from the muscles in your back. *Do not attempt to lift any objects that weigh more than 16 kg (35 lb) or objects that you think are too heavy for you.*
- Do not perform any action that causes hazards to the customer, or that makes the equipment unsafe.
- Before you start the machine, ensure that other service representatives and the customer's personnel are not in a hazardous position.
- Place removed covers and other parts in a safe place, away from all personnel, while you are servicing the machine.
- Keep your tool case away from walk areas so that other people will not trip over it.
- Do not wear loose clothing that can be trapped in the moving parts of a machine. Ensure that your sleeves are fastened or rolled up above your elbows. If your hair is long, fasten it.
- Insert the ends of your necktie or scarf inside clothing or fasten it with a nonconductive clip, approximately 8 centimeters (3 inches) from the end.
- Do not wear jewelry, chains, metal-frame eyeglasses, or metal fasteners for your clothing.

Remember: Metal objects are good electrical conductors.

- Wear safety glasses when you are: hammering, drilling soldering, cutting wire, attaching springs, using solvents, or working in any other conditions that might be hazardous to your eyes.
- After service, reinstall all safety shields, guards, labels, and ground wires. Replace any safety device that is worn or defective.
- Reinstall all covers correctly before returning the machine to the customer.

Electrical Safety

Observe the following rules when working on electrical equipment.

Important

Use only approved tools and test equipment. Some hand tools have handles covered with a soft material that does not insulate you when working with live electrical currents.

Many customers have, near their equipment, rubber floor mats that contain small conductive fibers to decrease electrostatic discharges. Do not use this type of mat to protect yourself from electrical shock.

- Find the room emergency power-off (EPO) switch, disconnecting switch, or electrical outlet. If an electrical accident occurs, you can then operate the switch or unplug the power cord quickly.
- Do not work alone under hazardous conditions or near equipment that has hazardous voltages.
- Disconnect all power before:
 - Performing a mechanical inspection
 - Working near power supplies
 - Removing or installing main units
- Before you start to work on the machine, unplug the power cord. If you cannot unplug it, ask the customer to power-off the wall box that supplies power to the machine and to lock the wall box in the off position.
- If you need to work on a machine that has *exposed* electrical circuits, observe the following precautions:
 - Ensure that another person, familiar with the power-off controls, is near you.

Remember: Another person must be there to switch off the power, if necessary.
 - Use only one hand when working with powered-on electrical equipment; keep the other hand in your pocket or behind your back.

Remember: There must be a complete circuit to cause electrical shock. By observing the above rule, you may prevent a current from passing through your body.
 - When using testers, set the controls correctly and use the approved probe leads and accessories for that tester.
 - Stand on suitable rubber mats (obtained locally, if necessary) to insulate you from grounds such as metal floor strips and machine frames.

Observe the special safety precautions when you work with very high voltages; these instructions are in the safety sections of maintenance information. Use extreme care when measuring high voltages.

- Regularly inspect and maintain your electrical hand tools for safe operational condition.
- Do not use worn or broken tools and testers.
- *Never assume* that power has been disconnected from a circuit. First, *check* that it has been powered-off.
- Always look carefully for possible hazards in your work area. Examples of these hazards are moist floors, nongrounded power extension cables, power surges, and missing safety grounds.
- Do not touch live electrical circuits with the reflective surface of a plastic dental mirror. The surface is conductive; such touching can cause personal injury and machine damage.
- Do not service the following parts *with the power on* when they are removed from their normal operating places in a machine:
 - Power supply units
 - Pumps
 - Blowers and fans
 - Motor generators

and similar units. (This practice ensures correct grounding of the units.)

- If an electrical accident occurs:
 - **Use caution; do not become a victim yourself.**
 - **Switch off power.**
 - **Send another person to get medical aid.**

Safety Inspection Guide

The intent of this inspection guide is to assist you in identifying potentially unsafe conditions on these products. Each machine, as it was designed and built, had required safety items installed to protect users and service personnel from injury. This guide addresses only those items. However, good judgment should be used to identify potential safety hazards due to attachment of non-IBM features or options not covered by this inspection guide.

If any unsafe conditions are present, you must determine how serious the apparent hazard could be and whether you can continue without first correcting the problem.

Consider these conditions and the safety hazards they present:

- Electrical hazards, especially primary power (primary voltage on the frame can cause serious or fatal electrical shock).
- Explosive hazards, such as a damaged CRT face or bulging capacitor
- Mechanical hazards, such as loose or missing hardware

The guide consists of a series of steps presented in a checklist. Begin the checks with the power off, and the power cord disconnected.

Checklist:

1. Check exterior covers for damage (loose, broken, or sharp edges).
2. Power-off the computer. Disconnect the power cord.
3. Check the power cord for:
 - a. A third-wire ground connector in good condition. Use a meter to measure third-wire ground continuity for 0.1 ohm or less between the external ground pin and frame ground.
 - b. The power cord should be the appropriate type as specified in the parts listings.
 - c. Insulation must not be frayed or worn.
4. Remove the cover.
5. Check for any obvious non-IBM alterations. Use good judgment as to the safety of any non-IBM alterations.
6. Check inside the unit for any obvious unsafe conditions, such as metal filings, contamination, water or other liquids, or signs of fire or smoke damage.
7. Check for worn, frayed, or pinched cables.
8. Check that the power-supply cover fasteners (screws or rivets) have not been removed or tampered with.

Handling Electrostatic Discharge-Sensitive Devices

Any computer part containing transistors or integrated circuits (ICs) should be considered sensitive to electrostatic discharge (ESD). ESD damage can occur when there is a difference in charge between objects. Protect against ESD damage by equalizing the charge so that the machine, the part, the work mat, and the person handling the part are all at the same charge.

Notes:

1. Use product-specific ESD procedures when they exceed the requirements noted here.
2. Make sure that the ESD protective devices you use have been certified (ISO 9000) as fully effective.

When handling ESD-sensitive parts:

- Keep the parts in protective packages until they are inserted into the product.
- Avoid contact with other people.
- Wear a grounded wrist strap against your skin to eliminate static on your body.
- Prevent the part from touching your clothing. Most clothing is insulative and retains a charge even when you are wearing a wrist strap.
- Use the black side of a grounded work mat to provide a static-free work surface. The mat is especially useful when handling ESD-sensitive devices.
- Select a grounding system, such as those listed below, to provide protection that meets the specific service requirement.

Note: The use of a grounding system is desirable but not required to protect against ESD damage.

- Attach the ESD ground clip to any frame ground, ground braid, or green-wire ground.
- Use an ESD common ground or reference point when working on a double-insulated or battery-operated system. You can use coax or connector-outside shells on these systems.
- Use the round ground-prong of the AC plug on AC-operated computers.

Grounding Requirements

Electrical grounding of the computer is required for operator safety and correct system function. Proper grounding of the electrical outlet can be verified by a certified electrician.

Laser Compliance Statement

The CD-ROM drive in the ThinkPad computer is a laser product. The CD-ROM drive's classification label (shown below) is located on the drive.

CLASS 1 LASER PRODUCT
LASER KLASSE 1
LUOKAN 1 LASERLAITE
APPAREIL A LASER DE CLASSE 1
KLASSE 1 LASER APPARAT

The CD-ROM drive is certified in the U.S. to conform to the requirements of the Department of Health and Human Services 21 Code of Federal Regulations (DHHS 21 CFR) Subchapter J for Class 1 laser products.

In other countries, the drive is certified to conform to the requirements of EN60825.



CAUTION:











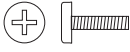



Do not open the drive; no user adjustments or serviceable parts are inside.

Class 1 laser products are not considered to be hazardous. The CD-ROM drive has an internal Class I (1), 0.5-milliwatt, aluminum gallium-arsenide laser that operates at a wavelength of 760 to 810 nanometers.





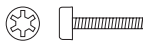





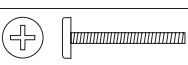

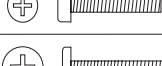

The design of the laser system and the CD-ROM drive ensures that there is no exposure to laser radiation above a Class 1 (1) level during normal operation, user maintenance, or servicing conditions.

Screw Size Chart

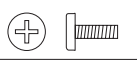

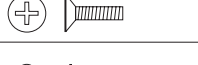

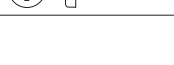









Use the chart below to match the size and shape of the screws used in the computer you are servicing.

A		Silver
B		Black
C		Silver
D		Brass
E		Black
F		Black
G		Black
H		Brass
J		Silver
K		Brass
L		Silver
M		Silver
N		Silver
P		Black
Q		Brass

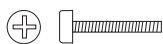
Screw Size Chart (continued): Use the chart below to match the size and shape of the screws used in the computer you are servicing.

R		Brass
S		Black
T		Brass
U		Black
V		Brass
W		Black
X		Black
Y		Brass
Z		Brass
AA		Black
BB		Brass
CC		Brass
DD		Black
EE		Black
FF		Silver

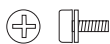
Screw Size Chart (continued): Use the chart below to match the size and shape of the screws used in the computer you are servicing.

GG		Silver
HH		Brass
JJ		Silver
KK		Black
LL		Brass
MM		Brass
NN		Silver
PP		Brass
QQ		Brass
RR		Brass
SS		Brass
TT		Black
UU		Black
WW		Silver
XX		Black

ThinkPad 340x (IBM 2610)

General Checkout	25
Memory Checkout	26
System Board	27
Keyboard/Auxiliary Input Device Checkout	27
TrackPoint II and III Checkout	28
Diskette Drive Test	28
Power Systems Checkout	29
Power Management Features	33
Symptom-to-FRU Index	34
Numeric Error Codes	35
FRU Codes	37
Beep Symptoms	38
No Beep Symptoms	38
LCD Related Symptoms	39
Keyboard/TrackPoint II or III Related Symptoms	40
Indicator Related Symptoms	40
Power Related Symptoms	40
Function/Audio Related Symptoms	41
Peripheral Device Related Symptoms	42
Other Symptoms	42
Intermittent Problems	42
Undetermined Problems	42
Related Service Procedures	43
Status Indicators	44
How to Run the Diagnostics	45
Error Log	45
Reset Pushbutton	46
Checking the Installed Devices List	46
How to Run the Low Level Format	46
PC Test Card LED	46
Fn Key Combinations	47
How To Run the Keyboard Diagnostics	47
Product Overview	48
FRU Removals and Replacements	49
1010 Rear Connector Door	50
1020 Battery Pack	50
1030 Backup Battery	51
1040 IC DRAM Card	51
1050 Standby Battery	51
1060 Top Cover	52
1070 Indicator Card	53
1080 Keyboard Unit	54
1090 LCD Assembly	55
1100 Diskette Drive	57
1110 Hard Disk Drive	57
1120 System Board/Speaker	58
Locations	59
System (Front View)	59
System (Rear View)	60
System (Interior View)	60
System Board	61

Indicator Card	61
Parts Listing	62
Option Parts List	65

General Checkout

Use the following procedure as a guide for computer problems. The diagnostic tests are intended to test *only* IBM products. Non-IBM products, prototype cards, or modified options can give false errors and invalid system responses.

1. Obtain the failing symptoms in as much detail as possible.
2. Verify the symptom. Attempt to recreate the failure by running the diagnostic tests or retrying the same operation.

Note: To run the diagnostics, refer to “How to Run the Diagnostics” on page 45.

3. Use the following table with the verified symptom to determine which page to go to. Search the symptoms column and find the description that best matches your symptom; then go to the page shown in the “Go to” column.

Symptom	Go to
Power failure. (The power indicator does not go on or stay on.)	“Power Systems Checkout” on page 29.
POST does not complete. No beeps/error code are indicated.	“Symptom-to-FRU Index” on page 34, and then use the No Beep Symptoms table.
POST beeps, but no error codes are displayed.	“Symptom-to-FRU Index” on page 34, and then use the Beep Symptoms table.
POST detected an error and displayed numeric error codes.	“Symptom-to-FRU Index” on page 34, and then use the Numeric Error Codes table.
The diagnostic test detected an error and displayed an FRU code.	“FRU Codes” on page 37.
The configuration is not the same as the installed devices.	“Checking the Installed Devices List” on page 46.
Other symptoms (such as LCD display problems).	“Symptom-to-FRU Index” on page 34, and then use the table for related symptoms.
Symptoms cannot be recreated. (Intermittent problems.)	Use the customer reported symptoms and go to “Symptom-to-FRU Index” on page 34.

Memory Checkout

See the following table for the available memory size of each card.

IC DRAM	Memory size
0 MB	3712 KB
2 MB	5760 KB
4 MB	7808 KB
8 MB	11904 KB

Memory errors might stop system operations, show error messages on the screen, or hang the system.

Use the following procedure to isolate memory problems.

Note: Make sure that the memory card is fully installed into the connector. Loose connections can cause errors.

1. Power-off the computer and remove the IC DRAM card from its slot (if installed).
2. Press and hold the F1 key; then power-on the computer. Hold the F1 key down until the Easy-Setup screen appears.
3. Select **Test** and press enter.
4. Select **Memory** and press enter to run the memory test on base memory. If an error appears, replace the system board.
5. Power-off the computer and reinstall the IC DRAM card; then power-on the computer. Verify the memory size; then test the memory. If an error appears, replace the IC DRAM card.

If memory problems occur intermittently, use the loop option to repeat the test. When the test detects an error, an error log is printed on the printer connected to the parallel port. See "Error Log" on page 45 for more information.

System Programs in Flash Memory: System setup programs and diagnostic tests are stored in Flash memory.

Flash Memory Update: A flash memory update is required for the following conditions:

- Connecting the AC Adapter, and installing the *charged* battery pack in the computer.
- New versions of system programs.
- New features or options are added.

To update the flash memory, do the following.

1. Get the appropriate diskette which contains the update.
2. Insert the **System Program Service Diskette** into drive A and power-on the computer.
3. Select **Update system programs** from the menu.

System Board

The processing functions for the computer are performed by the system board. When a numeric code calls out the system board, use the following procedure to isolate the problem.

1. Run the system board test to verify the symptom.
This test verifies the system board. If no error is detected, return to "General Checkout" on page 25.
2. If FRU code 10 appears, replace the system board.
3. Rerun the test to verify the fix.

If above procedure does not correct the problem, go to "Undetermined Problems" on page 42.

Keyboard/Auxiliary Input Device Checkout

Remove the external keyboard if the internal keyboard is to be tested.

If the internal keyboard does not work or an unexpected character appears, make sure that the three flexible cables extending from the keyboard are correctly seated in the connectors on the system board.

If the keyboard cable connection is correct, run the **Keyboard Test** by doing the following:

1. Go to advanced diagnostic menu screen by pressing **Ctrl+A** in the basic diagnostic menu.
2. Press **Ctrl+K**; a layout of the keyboard appears on the screen.
3. Check that when each key is pressed, the key position on the keyboard layout on the screen changes to a black square.

Notes:

- a. When a Fn key is pressed, a black square briefly appears.
- b. Press the Esc key to return to the diagnostic menu.

If the tests detect a keyboard problem, do the following one at a time to correct the problem. Do not replace a non-defective FRU.

- Reseat the three cables.
- Replace the keyboard.
- Replace the system board.

The following auxiliary input devices are supported for this computer.

- Numeric keypad
- Mouse (PS/2 compatible)
- External keyboard (with keyboard/mouse cable)

If any of the above devices do not work, reseal the cable connector and repeat the failing operation.

If the problem does not occur again, recheck the connector.

If the problem is not corrected, replace the device, and then the system board.

TrackPoint II and III Checkout

If the TrackPoint II or III will not work, check the configuration in Easy-Setup by selecting **Keyboard** from the **Config** menu. If the configuration of the TrackPoint II or III is disabled, select **TrackPoint** to enable it.

If this does not correct the TrackPoint II or III problem, continue with the following.

The TrackPoint II or III does automatic compensations to adjust the pointer sensor. During this process, the pointer moves on the screen automatically for a short time. This self-acting pointer movement can occur when a slight, steady pressure is applied to the TrackPoint II or III pointer while the computer is powered on or while the system is running, or re-adjustment is required because the temperature has exceeded its normal operating range. This symptom does not indicate a hardware problem. No service actions are necessary if the pointer movement stops in a short period of time.

If a click button problem or pointing stick problem occurs, do the following:

1. Go to the Easy-Setup screen.
2. Select an item with the pointing stick.
3. Press either the left or right click button.
4. Verify that both buttons work correctly.

If either the pointing stick or the click button will not work, do the following actions one at a time to correct the problem. Do not replace a non-defective FRU.

- Reseat the three keyboard cables.
- Replace the keyboard.
- Replace the system board.

Diskette Drive Test

Do the following to isolate the problem to a controller, drive, or diskette. A scratch, write enabled, non-defective 2HD diskette is required.

Note: Make sure that the diskette does not have more than one label attached to it. Multiple labels can cause damage to the drive or can cause the drive to fail.

1. Do following to select the test device:
 - Select the advanced diagnostic mode and select **Tool**; then select the icon **FDD** and press the

space key. A ✓ mark appears next to the selected icon. Insert the **blank** diskette when instructed.

2. Run the diskette drive test.
 3. If the controller test detects an error, FRU code 10 appears. Replace the system board.
 4. If the controller test runs without errors, the drive read/write tests start automatically.
 5. If the drive test detects an error, FRU code 50 appears. If the diskette itself is known to be good, replace the drive.
- If no errors occur at the FDD position, the drive is not defective.

Power Systems Checkout

To verify the symptom of the problem, power-on the computer using each of the power sources available as follows.

1. Remove the battery pack.
2. Connect the AC Adapter and check that power is supplied.
3. Disconnect the AC Adapter and install the charged battery pack; then check that power is supplied by battery pack.

If you suspect a power problem, see the appropriate power supply check listed below.

- "Checking the AC Adapter."
- "Checking the Battery Pack" on page 30.
- "Checking the Backup Battery" on page 31.
- "Checking the Standby Battery" on page 32.

Checking the AC Adapter: You are here because the computer fails only when the AC Adapter is used. If the power-on indicator does not turn on, check the power cord of the AC Adapter for correct continuity and installation.

1. Unplug the AC Adapter cable from the computer and measure the output voltage at the plug of the AC Adapter cable. See the following figure.

AC Adapter (30W, 40W):

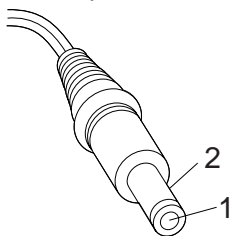

Pin	Voltage (V dc)
1	+17.1 to +18.9
2	Return

AC Adapter (35W):

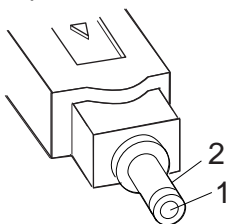

Pin	Voltage (V dc)
1	+15.5 to +17.0
2	Return

- If the voltage is correct, replace the system board. If the problem is not corrected, go to “Undetermined Problems” on page 42.
 - If the voltage is not correct, go to the next step.
2. Unplug the AC Adapter cable from the ac power outlet and wait five minutes or longer to allow the protection circuit to be fully discharged and initialized.
 3. Plug the AC Adapter cable into the ac power outlet.
 4. Measure the output voltage of the AC Adapter.
 5. If the voltage is still not correct, replace the AC Adapter.

Note: An audible noise from the AC Adapter does not always indicate a defective adapter.

Checking the Battery Pack

1. Power-off the computer.
2. Remove the battery pack and measure the voltage between battery terminals 1 (+) and 4 (-). See the following figure.

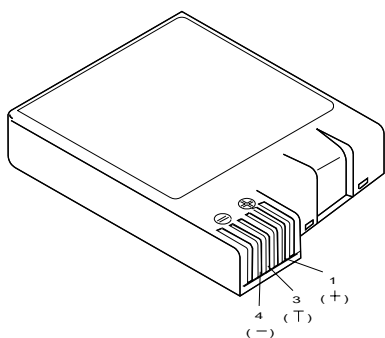

Terminal	Voltage (V dc) / Signal	
	340 (NiCd)	340CSE (NiMH)
1	+10.0 to +18.0	+10.0 to +16.0
2	NC	0 Ω+0 ground (-)
3	10 kΩ between ground (-)	
4	Ground (-)	

- If the voltage is less than +10.0 V dc, the battery pack has been discharged or is defective. Recharge the battery. If the recharging does not work, go to Step 5 to check the charging circuit.

If the voltage is still less than +10.0 V dc after the recharging, replace the battery.

- If the voltage is more than +8.0 V dc, measure the resistance between battery terminals 3 and 4. The resistance must be 4 to 30 kilohms.

If the resistance is not correct, replace the battery pack.

If the resistance is correct, replace the system board.

- To check the charging circuit, do the following. Plug in the AC Adapter with the battery pack removed; then power-on the computer.
- Measure the charging voltage between terminals 1 (+) and 4 (-) on the computer.
- If the voltage is less than +10.0 Vdc, replace the system board. If the voltage is more than +10.0 Vdc, the charging circuit is working correctly, replace the battery pack.

Checking the Backup Battery

- Power-off the computer and unplug the AC Adapter from the computer.
- Remove the backup battery.
- Measure the voltage of the backup battery. See the following figure.

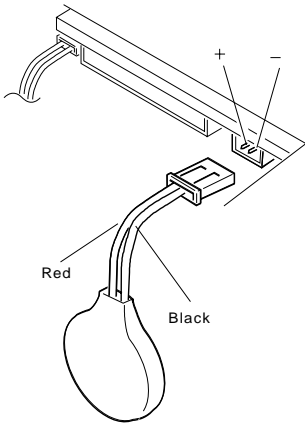

Wire	Voltage (V dc)
Red	+2.9 to +3.3
Black	Ground

- If the voltage is correct, replace the system board.
- If the voltage is not correct, the backup battery has been discharged. Replace the backup battery.
- If the backup battery discharges quickly after replacement, replace the system board.

Checking the Standby Battery: Be careful not to cause a short circuit when measuring the voltage.

1. Power-off the computer and unplug the AC Adapter from the computer.
2. Remove the standby battery.
3. Measure the voltage of the standby battery.
 - If the voltage between red and black is 3.5 V dc or greater, the voltage is correct. Go to Step 9 on page 33 to verify standby battery operation.
 - If the voltage is less than 3.5 V dc, go to the next step.
4. Plug the AC Adapter into the computer and power-on the computer.
5. Measure the output voltage at the connector on the system board.

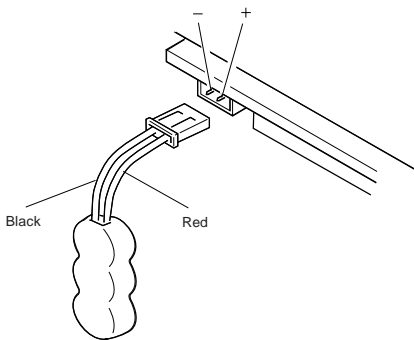

Pin	Voltage (V dc)
+	+4.0
-	Ground

- If the voltage is less than +4.0 V dc, replace the system board.
 - If the voltage is more than +4.0 V dc, power-off the computer, replace the standby battery, and go to the next step.
6. Ensure that the AC Adapter is plugged into the computer; then power-on the computer.
 7. Charging of the standby battery starts. A depleted battery needs approximately 30 minutes to be recharged to the operational voltage of +3.5 V dc.
 8. Unplug the AC Adapter.
 9. Verify the standby battery function by removing and installing the battery pack during suspend mode.

Note: Removing and installing the battery pack during suspend mode should be done within one minute.

The resume operation must start. If the resume operation does not work, switching of power from the battery pack to standby battery will not be correct. Replace the system board.

Power Management Features

Two power management modes are provided by the computer to save power consumption and prolong battery power. For the details of the two modes, see the latest volume of the *Hardware Maintenance Manual* for ThinkPad computers.

Standby Mode: When in standby mode, the following occurs:

- The LCD backlight turns off.
- The hard disk motor stops.

Suspend Mode: When in suspend mode, the following occurs:

- The LCD power is powered-off.
- The hard disk is powered-off.
- The CPU is stopped.

Notes:

1. In the ThinkPad Features Program, the computer can be set to “Will not suspend even if LCD is closed.”
2. When the computer is powered with ac power and is used with one of the following IBM PC cards, the computer enters *standby mode*; the PC card and application program remain active.
 - 3270 Emulation Credit Card Adapter
 - 5250 Emulation Credit Card Adapter
 - Token-Ring 16/4 Credit Card Adapter
 - Credit Card Adapter for Ethernet
3. During the following conditions, the computer cannot enter suspend mode.
 - While the communication link is running.
 - When a serial mouse or other pointing device are selected in the **Config** menu of Easy-Setup.

Symptom-to-FRU Index

The Symptom-to-FRU Index lists the symptoms, errors, and possible causes. (It can be used to help you decide which FRUs to have available when servicing the computer.) The most likely cause is listed first.

Perform the FRU replacement or actions in the sequence shown in the “FRU/Action” column. If a FRU does not solve the problem, put the original part back in the computer and perform the next action.

Numeric error codes show the errors detected in POST or system operation. In the following error codes, **X** can be any number.

If no codes are available, use narrative symptoms.

If the symptom is not listed, go to “Undetermined Problems” on page 42.

Note: For IBM devices not supported by diagnostic codes for the Model 340 and 340CSE, see the manual for that device.

Numeric Error Codes

Symptom/Error	FRU/Action
10X	1. System Board
110	<ol style="list-style-type: none"> 1. Go to “Memory Checkout” on page 26. 2. IC DRAM Card 3. System Board
111	<ol style="list-style-type: none"> 1. Go to “Memory Checkout” on page 26. 2. System Board
161	<ol style="list-style-type: none"> 1. Go to “Checking the Backup Battery” on page 31. 2. Backup Battery 3. System Board
163 (Time and Date was not set.)	<ol style="list-style-type: none"> 1. Set Time and Date. 2. System Board
173 (Configuration data were lost.)	<ol style="list-style-type: none"> 1. Select OK in the error screen; then set time and date. 2. Backup Battery 3. System Board
174 (Perform “Checking the Installed Devices List” on page 46 before changing any FRUs.)	<ol style="list-style-type: none"> 1. Check Device Configuration. 2. System Board 3. Diskette Drive Assembly 4. Hard Disk Drive Assembly
184 (POP check sum error.)	1. Reset the POP in Easy-Setup.
190 (A depleted battery pack was installed when the power was on.)	1. Go to “Checking the Battery Pack” on page 30.
191XX	1. System Board
199XX	1. System Board
1XX	1. System Board
2XX	<ol style="list-style-type: none"> 1. Go to “Memory Checkout” on page 26. 2. IC DRAM Card 3. System Board

Symptom/Error	FRU/Action
301, 303, 304, 305, 3XX	<ol style="list-style-type: none"> 1. Go to “Keyboard/Auxiliary Input Device Checkout” on page 27. 2. Keyboard 3. External Numeric Keypad 4. External Keyboard 5. Keyboard/Mouse Cable 6. System Board
601, 6XX	<ol style="list-style-type: none"> 1. Go to “Diskette Drive Test” on page 28. 2. Diskette Drive Assembly 3. Diskette 4. System Board
602 (Diskette read error.)	<ol style="list-style-type: none"> 1. Go to “Diskette Drive Test” on page 28. 2. Diskette 3. Diskette Drive Assembly
604 (Non-acceptable ID was read from the diskette drive.)	<ol style="list-style-type: none"> 1. Go to “Diskette Drive Test” on page 28. 2. Diskette Drive Assembly 3. System Board
11XX	<ol style="list-style-type: none"> 1. Serial Device (First) 2. Communication Cable 3. System Board
12XX	<ol style="list-style-type: none"> 1. Serial Device (Second) 2. Communication Cable 3. System Board
17XX	<ol style="list-style-type: none"> 1. Hard Disk Drive 2. System Board
24XX	<ol style="list-style-type: none"> 1. System Board
808X	<ol style="list-style-type: none"> 1. PCMCIA Slot Assembly 2. PCMCIA Device 3. System Board
860X (Pointing device error when TrackPoint II or III is disabled.)	<ol style="list-style-type: none"> 1. External Mouse 2. External Keyboard 3. System Board
861X (Pointing device error when TrackPoint II or III is enabled.)	<ol style="list-style-type: none"> 1. Reseat the keyboard TrackPoint II or III cable. (See “1080 Keyboard Unit” on page 54.) 2. Keyboard 3. External Mouse 4. System Board

Symptom/Error	FRU/Action
I9990301 I9990302 I9990305	<ol style="list-style-type: none"> 1. Reseat the boot device. 2. Check the startup sequence for the correct boot device. 3. Check that the operating system has no failures, and is installed correctly.
I9990303	1. System Board
Other codes not listed above	1. Go to “Undetermined Problems” on page 42.

FRU Codes

If an error is detected by the diagnostic tests, a *four-digit* FRU code is displayed. The FRU code indicates two suspected FRUs. Replace the FRU that is indicated by the *two leftmost digits* first, then replace the FRU indicated by the *two rightmost digits*. No FRU is assigned to code 00. If only one FRU is suspected, the other FRU code is filled with zeros. See the referenced page before replacing the FRU.

FRU Code	FRU/Action
10	System Board
20	Memory (See “Memory Checkout” on page 26.)
30	Reserved
32	External Keyboard
33	External Mouse
40	LCD Assembly
45	External CRT
50	<ol style="list-style-type: none"> 1. Reseat the Diskette Drive 2. Diskette Drive
60	<ol style="list-style-type: none"> 1. Reseat the Hard Disk Drive 2. Hard Disk Drive
81	Internal Modem Card (if installed)
90	Reserved

Note: The device ID and error codes are used to indicate the detail portion of the FRU which caused the error. If replacing a FRU does not correct a problem, see the Device ID or error code from the previous failure. If they have changed, the cause might be because the new FRU is defective or that the FRU was incorrectly installed.

If the problem remains after replacement of the FRUs, go to “Undetermined Problems” on page 42.

Beep Symptoms

Symptom/Error	FRU/Action
Continuous beeps.	1. System Board
One beep and a blank, unreadable, or flashing LCD.	1. Reseat the LCD connector. (See "1090 LCD Assembly" on page 55.) 2. LCD Assembly 3. System Board
One beep, and the message "Unable to access boot source."	1. Reseat the boot device. 2. Boot Device 3. System Board
One long, two short beeps and a blank or unreadable LCD.	1. System Board 2. LCD Assembly
One long beep followed by four short beeps each time the power switch is operated. (System cannot power-on due to low battery voltage.)	1. Connect the AC Adapter or install a fully-charged battery.
One long and one short beep.	1. System Board
One beep every second. (System is shutting down due to low battery voltage.)	1. Connect the AC Adapter or install a fully-charged battery (allows the system to completely shutdown before the battery is charged).
Two short beeps with error codes.	1. POST error. (See "Numeric Error Codes" on page 35.)
Two short beeps with blank screen.	1. System Board

No Beep Symptoms

Symptom/Error	FRU/Action
No beep, power-on indicator not on, and a blank LCD during POST.	1. Go to "Power Systems Checkout" on page 29. 2. System Board 3. Power Sources
No beep, power-on indicator on, and a blank LCD during POST.	1. System Board
No beep, power-on indicator on, and a blinking cursor only during POST.	1. System Board

Symptom/Error	FRU/Action
No beep during POST, but system runs correctly.	<ol style="list-style-type: none"> 1. Turn the volume up and listen to the speaker. 2. Speaker

LCD Related Symptoms

Symptom/Error	FRU/Action
Flicker	<ol style="list-style-type: none"> 1. Do not replace any FRUs. In certain brightness/contrast settings, screen flicker can be seen because of technical limitations.
No beep, power-on indicator on, and a blank LCD during POST.	<ol style="list-style-type: none"> 1. System Board
<ul style="list-style-type: none"> • LCD backlight not working • LCD too dark • LCD brightness cannot be adjusted • LCD contrast cannot be adjusted. 	<ol style="list-style-type: none"> 1. Reseat the LCD connector. (See "1090 LCD Assembly" on page 55.) 2. LCD Assembly
<ul style="list-style-type: none"> • LCD screen unreadable, or • Characters missing pels, or • Screen abnormal, or • Wrong characters displayed. 	<ol style="list-style-type: none"> 1. Reseat the LCD connector. (See "1090 LCD Assembly" on page 55.) 2. System Board 3. LCD Assembly
LCD has extra horizontal or vertical lines displayed.	<ol style="list-style-type: none"> 1. LCD Assembly

LCD FRU Replacement Notice: If missing or discolored dots appear on the LCD, carefully read the following note to determine whether you should replace the LCD.

- **Do not** replace the LCD for defective pixels if dots that are less than half the area of a pixel are defective (a total of 11 dots are allowed).
- The LCD **is not** defective if the dots are functional but are slightly different in color from the immediate, surrounding area or appear as a "stain".

Keyboard/TrackPoint II or III Related Symptoms

Symptom/Error	FRU/Action
Keyboard (one or more keys) does not work, or works intermittently.	<ol style="list-style-type: none"> 1. Reseat the three keyboard cables. 2. Reseat the keytop. Ensure the rubber dome under the keytop is straight and in the correct direction, with the larger radius on the top. 3. Keyboard 4. System Board
TrackPoint II or III does not work.	<ol style="list-style-type: none"> 1. Go to “TrackPoint II and III Checkout” on page 28. 2. Keyboard 3. System Board
Pointer moves automatically or does not work correctly.	<ol style="list-style-type: none"> 1. See “TrackPoint II and III Checkout” on page 28.

Indicator Related Symptoms

Symptom/Error	FRU/Action
Indicator incorrectly remains off or on, but system runs correctly.	<ol style="list-style-type: none"> 1. Reseat the indicator card. 2. Indicator Card 3. System Board
Battery power status indicator blinks from green, yellow, to orange.	<ol style="list-style-type: none"> 1. Check that a correct battery is installed. 2. Battery Pack 3. System Board

Power Related Symptoms

Symptom/Error	FRU/Action
Power shut down during operation.	<ol style="list-style-type: none"> 1. Go to “Power Systems Checkout” on page 29. 2. Battery Pack 3. Remove the battery pack and let it cool for two hours. 4. Power Sources
The system will not power-off. (See “Reset Pushbutton” on page 46.)	<ol style="list-style-type: none"> 1. Press the Reset pushbutton. 2. System Board

Function/Audio Related Symptoms

Symptom/Error	FRU/Action
The system will not suspend or resume by opening or closing the keyboard.	<ol style="list-style-type: none"> 1. Go to “Suspend Mode” on page 34 and check that the computer can enter suspend mode. 2. Go to the Easy-Setup screen and press Fn+4. If the computer enters suspend mode, suspect that the application program is defective. 3. System Board
The system will not suspend or resume by opening or closing the LCD.	<ol style="list-style-type: none"> 1. Go to “Suspend Mode” on page 34 and that check that the computer can enter suspend mode. 2. Go to the Easy-Setup screen and press Fn+4. If the computer enters suspend mode, suspect that the application program is defective. 3. System Board
Battery Fuel-Gauge does not go higher than 90%.	<ol style="list-style-type: none"> 1. Go to “Checking the Battery Pack” on page 30 and see the note.
Modem problems. (If installed)	<ol style="list-style-type: none"> 1. Run the Internal Modem Test. 2. Check that the port is set to enable in Easy Setup. 3. Check that the port power is switched on by PS2.EXE. 4. Modem Card (if installed)
Memory count (size) appears differently from actual size.	<ol style="list-style-type: none"> 1. Go to “Memory Checkout” on page 26.
System configuration does not match the installed devices.	<ol style="list-style-type: none"> 1. Go to “Checking the Installed Devices List” on page 46.
System hangs intermittently.	<ol style="list-style-type: none"> 1. Go to “Intermittent Problems” on page 42.

Peripheral Device Related Symptoms

Symptom/Error	FRU/Action
External display does not work correctly.	1. See “External Display Self-Test” in the “Common Devices Checkout” section.
Printer problems.	1. Run Printer Self-test. 2. System Board 3. Parallel Port Device 4. Cable
Serial or parallel port device problems.	1. Device 2. Device Cable 3. System Board

Other Symptoms

Symptom/Error	FRU/Action
PCMCIA slot pin is damaged.	1. System Board

Note: If you cannot find a symptom or error in this list and the problem remains, see “Undetermined Problems.”

Intermittent Problems

Intermittent system hang problems can be caused by a variety of reasons that have nothing to do with a hardware defect such as: cosmic radiation, electrostatic discharge, or software errors. FRUs replacement should only be considered when a recurring problems exists.

When analyzing the intermittent problem, do the following:

1. Run the advanced diagnostic test for the system board in loop mode at least 10 times.
2. If no error is detected, do **not** replace any FRUs.
3. If any error is detected, replace the FRU shown by the FRU code. Rerun the test to verify that no more errors exist.

Undetermined Problems

You are here because the diagnostic tests did not identify which adapter or device failed, installed devices are incorrect, a short circuit is suspected, or the system is inoperative. Follow the procedures below to isolate the failing FRU (do not isolate non-defective FRUs).

Verify that all attached devices are supported by the computer.

Verify that the power supply being used at the time of the failure is operating correctly. (See “Power Systems Checkout” on page 29.)

1. Power-off the computer.

2. Check the cables, wires, and connectors for short circuits and open circuits. Visually check them for damage. If any problems are found, replace the FRU.
3. Remove or disconnect all of the following devices.
 - a. Non-IBM devices
 - b. Devices attached to the expansion bus connector
 - c. Printer, mouse, and other external devices
 - d. Battery pack
 - e. IC DRAM card
 - f. PC cards

Note: Remember that removing the hard disk drive, an IC DRAM card, or any adapter or device, might cause configuration errors. Ignore error code 174.
4. Power-on the computer.
5. Determine if the problem has changed.
6. If the problem does not occur again, reconnect the removed devices one at a time until you find the failing FRU.
7. If the problem remains, replace the following FRUs one at a time. Do not replace a non-defective FRU.
 - Modem card (if installed)
 - LCD assembly
 - System board







Related Service Procedures

This section provides information about the following:

- "Status Indicators" on page 44
- "How to Run the Diagnostics" on page 45
- "Error Log" on page 45
- "Reset Pushbutton" on page 46
- "Checking the Installed Devices List" on page 46
- "How to Run the Low Level Format" on page 46
- "PC Test Card LED" on page 46
- "Fn Key Combinations" on page 47
- "How To Run the Keyboard Diagnostics" on page 47

Status Indicators

The system status indicators show the current computer status in different colors (green, yellow, and orange).

Symbol	Color	Meaning
	Green	Battery is fully charged.
	Yellow (340)	Battery usable. Battery is charging (when the AC Adapter is used). Note: When the battery is fully charged, the indicator turns and stays green.
	Orange	Battery is low
	Blinking orange	Battery is almost depleted
	Blinking yellow (340)	Battery cannot be charged because of its high temperature. Note: When the temperature drops to the acceptable range, charging will start.
	Off (340CSE)	The battery is not installed.
	Orange	Diskette drive is in-use
	Orange	Hard disk drive in-use
	Green	Keyboard is in Num Lock mode
	Green	Keyboard is in Caps Lock mode
	Green	Keyboard is in Scroll Lock mode

Symbol	Color	Meaning
	Green	Computer is powered on

How to Run the Diagnostics

Use either the TrackPoint II or III or the cursor move keys to interact with the tests. The Enter key works the same as selecting the OK icon to reply OK.

1. Press and hold the F1 key; then power-on the computer. Hold the F1 key down until the Easy-setup screen appears.
2. Select **Test** and press Enter.
3. Select a device and press Enter to run the test.
4. The test progress screen appears.
5. **OK** appears when the test ends without any errors.
6. Start the **Advanced Diagnostic test** by pressing **Ctrl+A** on the basic diagnostic menu screen.
7. Select **Tool** to install the tools.
8. Select a device, press the **space** key, and install the tool. Multiple devices can be selected by repeating this step.
A √ mark appears for the selected device.
9. Select **OK** and press Enter if the selection is OK.
10. Select a device and press Enter to start the tests.
11. Select **Test All** to test all devices.
12. Select **Loop Test** to loop tests.

A loop option menu appears in which a device loop or all loop can be selected. Select a device and press the **space** key to select a device. Repeat this step to select multiple devices. Press Enter to start the diagnostic loop. If no device is selected, all device tests are looped.

13. To exit the loop, keep pressing **Ctrl+Pause** until the test exits.

Error Log

Diagnostic errors are printed on the printer that is attached to the parallel port when the error is detected. The error is also logged in the system memory.

Do the following to display the errors.

1. End the test, if it is running.
2. Press **Ctrl+A** to select the advanced diagnostic mode.
3. Press **Ctrl+E**.
4. The error log appears.
5. To exit the screen, select the cancel icon or press Esc.

The error log is not saved when system power is powered-off.

Reset Pushbutton

The reset pushbutton resets the system and forces the power to be powered-off .

Note: Use this pushbutton when the power is not completely off or the system is hung. See "System Board" on page 61 for the location of the pushbutton.

Checking the Installed Devices List

If a device is installed but the icon appears in a gray shade rather than a dark shade on the basic diagnostics screen, the device is defective. Reseat the device connectors. If the symptom remains, replace the device or the system board. If needed, adjust the contrast control to clearly distinguish the shades of the icon.

If a device that is not installed appears in a dark shade, do the following.

1. Replace the **first** device, such as a FDD, HDD, or PCMCIA.
2. If the problem remains, replace the system board.

PCMCIA, Parallel, and Serial icons are always displayed in dark shade, because the icons represent subsystems of the system board and not attachment of the devices.

How to Run the Low Level Format

Do the following to format the hard disk.

Before Formatting the Hard Disk

Make sure that the address of the drive to be formatted is correct. This procedure will erase all information on the disk.

1. Power-off the computer.
2. Insert the **ThinkPad 750Ce hardware maintenance diskette** into diskette drive **A** and power-on the computer.

Note: You can use this maintenance diskette for the Model 340CSE.

3. Select **Format the hard disk** from the main menu.
4. Select the drive from the menu.
5. Follow the instructions on the screen.

PC Test Card LED

The green LED on the PC test card turns on when the PCMCIA test is running. If the LED does not turn on, check that the card is installed correctly by reseating it. If the LED still does not turn on after the card is reseated, try using another slot for the test. If the LED still does not turn on and the test fails, replace the FRU shown in the diagnostic error code.

Fn Key Combinations

The following table shows the **Fn** key and function key combinations and their corresponding functions.

The Fn key works independently from the operating system. The operating system obtains the status through the system management interface to control the system.

Fn +	Description
F1	Reserved
F2	Fuel-gauge display ON/OFF
F3	Standby mode invocation
F4	Suspend mode invocation
F5	Audio volume Down
F6	Audio volume UP
F7	LCD/CRT display switching
F8	LCD normal/reverse switching
F9	Reserved
F10	Reserved
F11	Power management mode switching (Toggles High power, Medium, Low)
F12	Reserved

How To Run the Keyboard Diagnostics

Do the following to run the keyboard test.

1. Go to the advanced diagnostic screen menu by pressing **Ctrl+A** in the Easy-Setup menu.
2. Go to the keyboard diagnostic test menu by pressing **Ctrl+K**.
3. Check that when each key is pressed, the key position on the keyboard layout on the screen changes to a black square.

Note: When a Fn key is pressed, the black square briefly appears.

Product Overview

The following table shows an overview of the system features.

Feature	Description
Processor	<ul style="list-style-type: none">• 340<ul style="list-style-type: none">– IBM486 SLC2 25/50MHz, on the system board• 340CSE<ul style="list-style-type: none">– IBM486 SLC2 25/50MHz, on the system board– IBM486 SLC2 33/66MHz, on the system board
Memory (Standard)	4MB (on the system board)
Memory (Option)	2MB, 4MB, 8MB, IC DRAM card (12MB is maximum)
CMOS RAM	128 Bytes
VGA Video	<ul style="list-style-type: none">• 340<ul style="list-style-type: none">– 9.4-inch, 64 gray, level DSTN LCD monochrome• 340CSE<ul style="list-style-type: none">– 9.4-inch, 256 color, DSTN LCD color– 10.4-inch, 256 color, DSTN LCD color
Diskette Drive	<ul style="list-style-type: none">• 0.720MB, 1.44MB (2-mode), 3.5-inch (for U.S. and European countries)• 0.720MB, 1.2MB, 1.44MB (3-mode), 3.5-inch (for Japan)
Hard Disk Drive	<ul style="list-style-type: none">• 340<ul style="list-style-type: none">– 125MB, 2.5-inch• 340CSE<ul style="list-style-type: none">– 200MB, 2.5-inch– 360MB, 2.5-inch
PCMCIA	One Type-III or Type-II

FRU Removals and Replacements

This section contains information about removals and replacements.

- **An electrostatic discharge (ESD) strap must be used to establish personal grounding.** The system board is sensitive to, and can be damaged by, electrostatic discharge. Establish personal grounding by touching a ground point with one hand before touching these units.
- Do not damage any part. Only certificated and trained personnel should service the computer.
- The arrows in the “Removals and Replacements” section show the direction of movement to remove a FRU, or to turn a screw to release the FRU. The step number with the arrow shows the correct sequence of removal. The circled numbers are sub-steps of the main step.
- When other FRUs must be removed before removing the failing FRU, they are listed at the top of the page.
- To replace a FRU, reverse the removal procedure and follow any notes that pertain to replacement. See “Locations” for internal cable connections and arrangement information.
- When replacing a FRU, use the correct screw size as shown in the table of each section.

Safety Notice 8: Translation on page 13

Before removing any FRU, power-off the computer, unplug all power cords from electrical outlets, remove the battery pack, and then disconnect any interconnecting cables.

Safety Notice 3: Translation on page 9

The battery pack contains Cadmium. Do not disassemble it, throw it into fire or water, or short-circuit it. Dispose of the battery pack as required by local ordinances or regulations.

Safety Notice 1: Translation on page 7

Before the computer is powered-on after FRU replacement, make sure all screws, springs, or other small parts, are in place and are not left loose inside the computer. Verify this by shaking the computer and listening for rattling sounds. Metallic parts or metal flakes can cause electrical shorts.

1010 Rear Connector Door

Remove the rear connector door by flexing it.

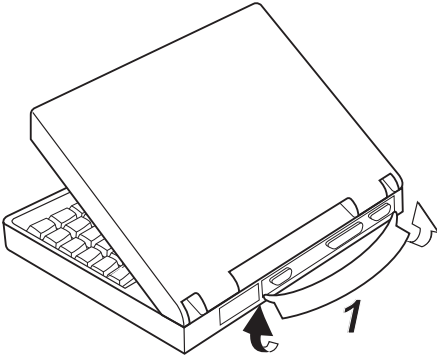

1020 Battery Pack

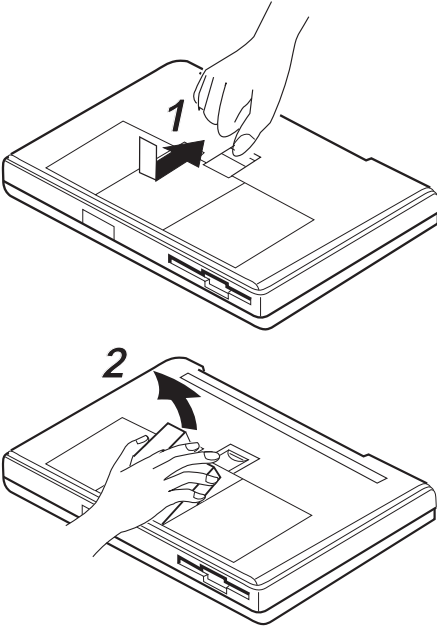

1030 Backup Battery

1040 IC DRAM Card

1050 Standby Battery

- Battery Pack (1020)
 - Step 2:** Standby Battery
 - Step 3:** IC DRAM Card
 - Step 4:** Backup Battery

Note

The IC DRAM card is sensitive to physical shock. Incorrect handling of the card can damage it.

Note: When removing the backup battery or standby battery, use the connector extractor (P/N 39G9977).

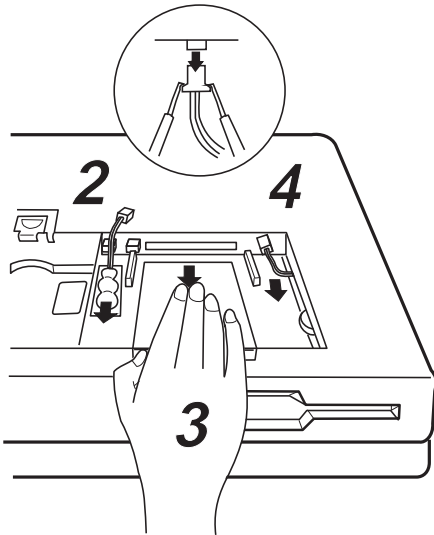
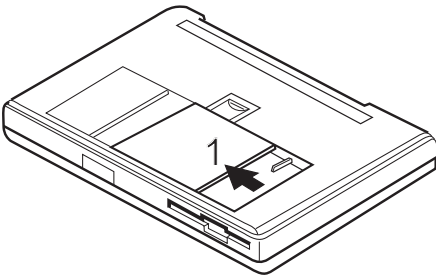

1060 Top Cover

- Battery Pack (1020)

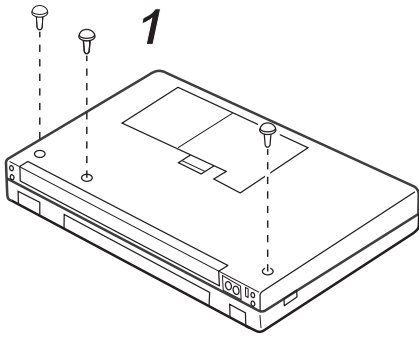

Step	Location (Quantity)	Length
1	Base cover (3)	12 mm

Note: Make sure you use the correct screw.

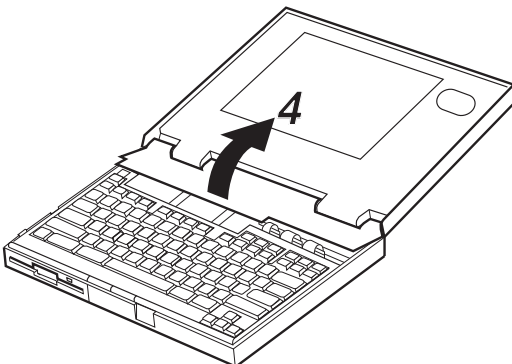
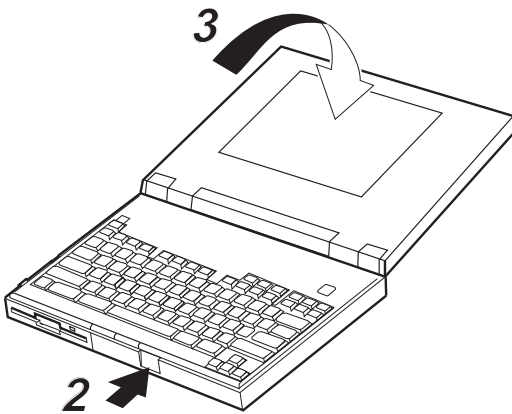

1070 Indicator Card

- Battery Pack (1020)
- Top Cover (1060)

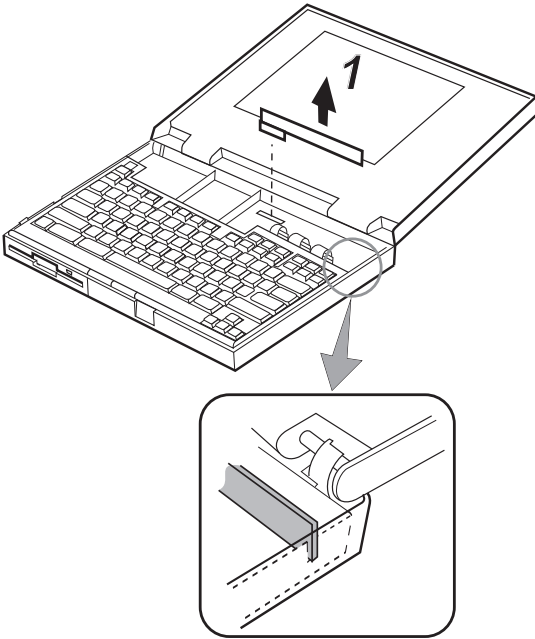

When Replacing

Be careful to not break the pins of the indicator card connector.

1080 Keyboard Unit

- Battery Pack (1020)
- Top Cover (1060)

Notes:

1. There are two keyboard latches on each side of the computer frame. Slide the keyboard as shown in step 2 to release the keyboard from those latches; then remove the keyboard. (Small arrows on the both sides of the keyboard show the locations of the latches.)
2. The keyboard has three cables; be careful not to damage the cables when you open the keyboard and to remove them.

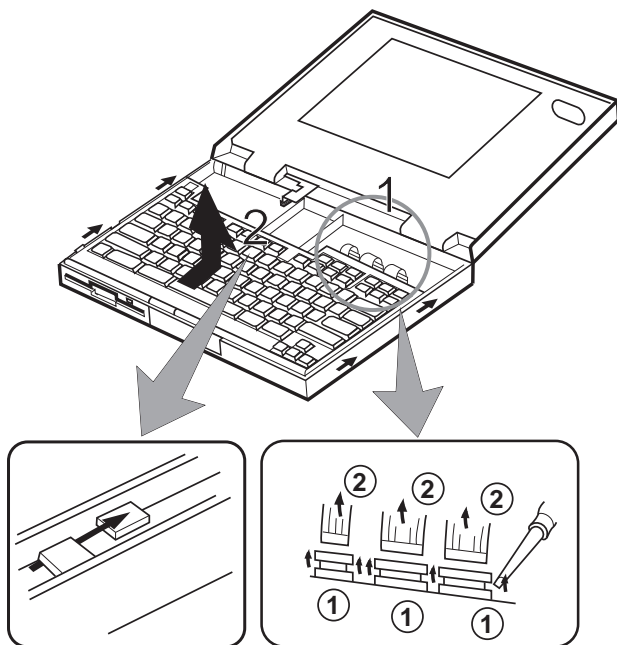

When Replacing

- Check that the three keyboard cables are clean, and inserted straight and fully into the connectors. Slide both ends of each connector latch at the same time to make sure that each cable is correctly inserted.
- Go to "Keyboard/Auxiliary Input Device Checkout" on page 27 and test all keys before returning the computer to the customer.

1090 LCD Assembly

- Battery Pack (1020)
- Top Cover (1060)

Safety Notice 5: Translation on page 11

If the LCD breaks and the fluid from inside the LCD gets into your eyes or on your hands, immediately wash the affected areas with water for at least 15 minutes. Seek medical care if any symptoms from the fluid are present after washing.

Caring for the LCD

- When cleaning of the LCD becomes necessary, gently wipe the LCD with a dry, soft cloth. Do not use alcohol or detergent to clean the LCD.
- To avoid damage to the LCD, do not scratch or apply any force to its surface.
- Do not put anything on the surface of the LCD.
- **Do not pull the LCD cable.** The cable can be damaged if it is disconnected without releasing the latch.

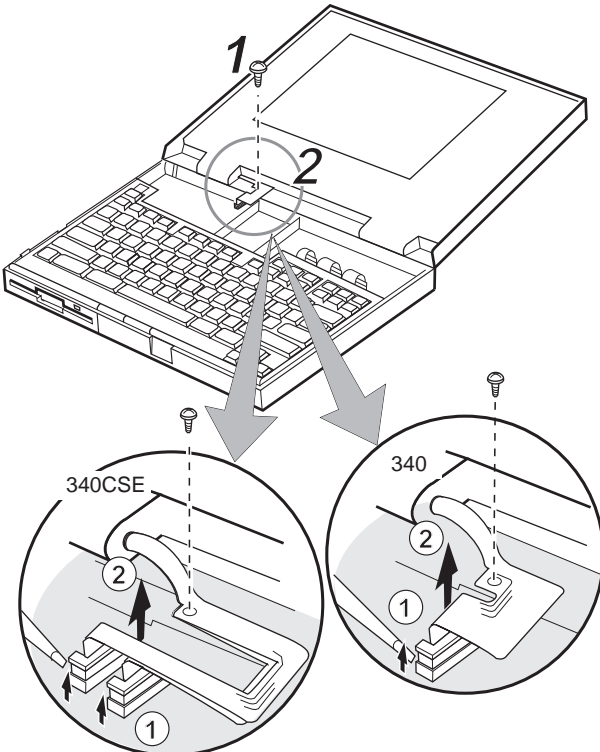

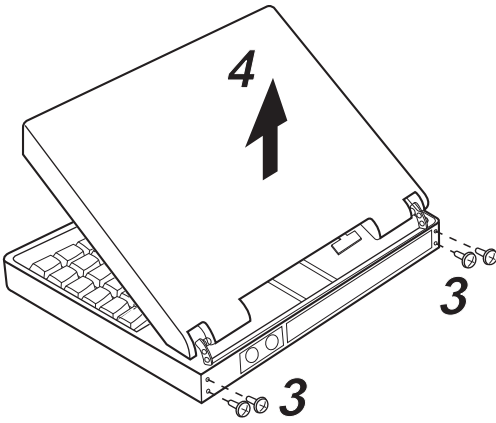

Use the following table for reference when replacing parts.

Step	Location (Quantity)	Length
1	LCD cable (1)	6 mm
3	LCD hinge (4)	8 mm
Note: Make sure you use the correct screw.		

1100 Diskette Drive

1110 Hard Disk Drive

- Battery Pack (1020)
- Top Cover (1060)
- Keyboard Unit (1080)

Steps 1, 2, 3, 4: Diskette Drive

Steps 5, 6: Hard Disk Drive

When Replacing

- Before removing the hard disk drive, have the user make a backup copy of all information on the hard disk
- Never remove the hard disk drive while the system is operating or is in suspend mode.
- Do not pull the hard disk cable. The cable can be damaged if it is disconnected without releasing the latch.
- Do not drop or apply any shock or extra force to the hard disk drive or diskette drive. They are sensitive to physical shock.

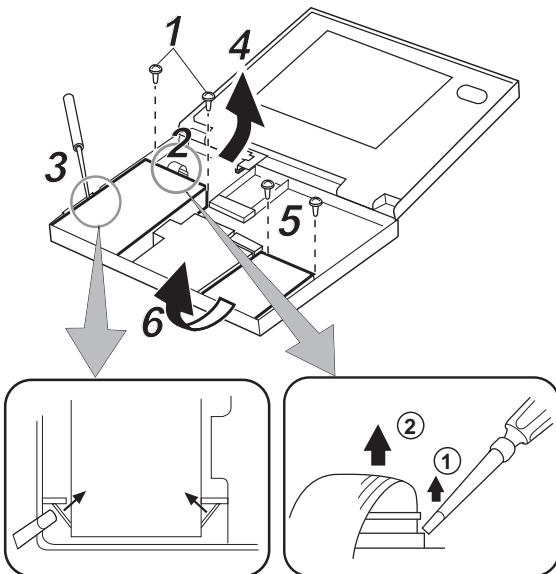

Use the following table for reference when replacing parts.

Step	Location (Quantity)	Length
1	Diskette Drive (2)	8 mm
5	Hard Disk Drive (2)	6 mm

Note: Make sure you use the correct screw.

1120 System Board/Speaker

- Rear Connector Door (1010)
- Battery Pack (1020)
- Backup Battery (1030)
- IC DRAM Card (1040)
- Standby Battery (1050)
- Top Cover (1060)
- Indicator Card (1070)
- Keyboard Unit (1080)
- Diskette Drive (1100)
- Hard Disk Drive (1110)

Step 1, 2, 3, 4: System Board

Step 4, 5: Speaker

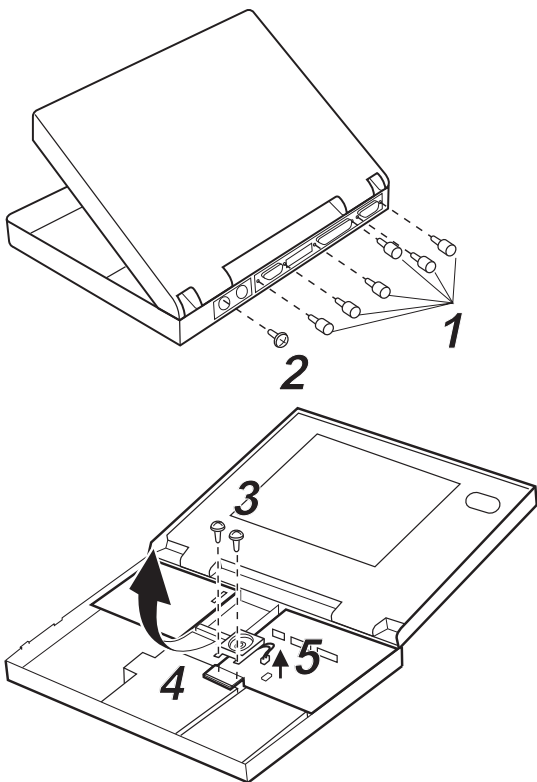

Step	Location (Quantity)	Length
1	I/O connector (6)	Hex-head screws
2	Base cover (1)	8 mm
3	Base cover (2)	12 mm
Note: Make sure you use the correct screws.		

Locations

System (Front View)

- 1** LCD
- 2** Contrast Control
- 3** Brightness Control
- 4** Status Indicator
- 5** Keyboard
- 6** LCD and Keyboard Latch
- 7** Click Button
- 8** Diskette-Eject Button
- 9** Diskette Drive
- 10** Fn Key
- 11** TrackPoint II/III

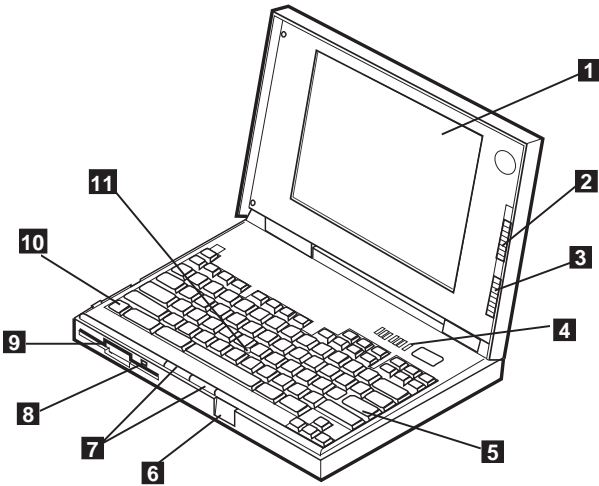

System (Rear View)

- 1** External Display Connector
- 2** Serial Connector
- 3** PCMCIA Slot
- 4** Serial Connector
- 5** Reset Pushbutton
- 6** Power Jack
- 7** External Input Device connector

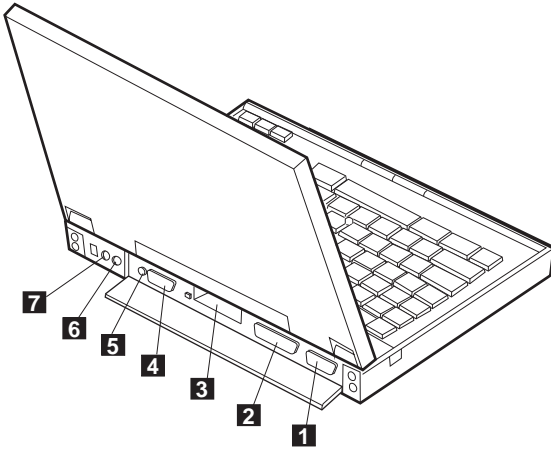

System (Interior View)

- 1** Backup Battery
- 2** IC DRAM Card Slot
- 3** Standby Battery
- 4** Battery Pack

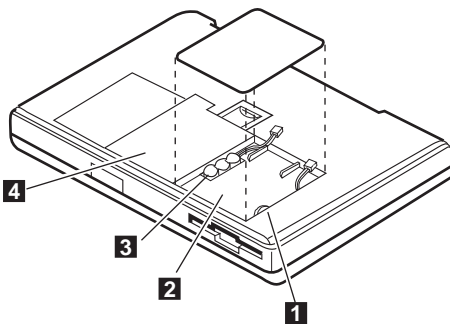

System Board

- 1** Internal Modem Card connector
(Modem model only)
- 2** External Display Connector
- 3** Parallel Connector
- 4** LCD connectors
- 5** PCMCIA Slot
- 6** Indicator Card Connector
- 7** Reset Pushbutton
- 8** LCD Inverter Power Connector (340CSE)
- 9** Serial Connector
- 10** Power Jack
- 11** External Input Device Connector
- 12** Keyboard Signal Connector
- 13** Hard Disk Drive Connector
- 14** Speaker Connector (340CSE only)
- 15** Keyboard TrackPoint II/III Connector
- 16** Battery Pack Terminal
- 17** POP Terminal
- 18** Standby Battery Connector
- 19** IC DRAM Card Connector
- 20** Diskette Drive Interface
- 21** Backup Battery Connector

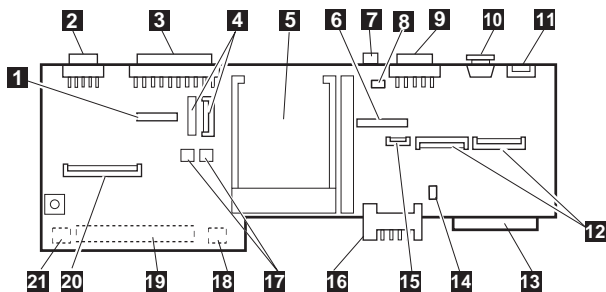

Indicator Card

- 1** Resume/Suspend Switch
- 2** Power Switch
- 3** System board Interface

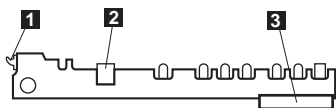

Parts Listing

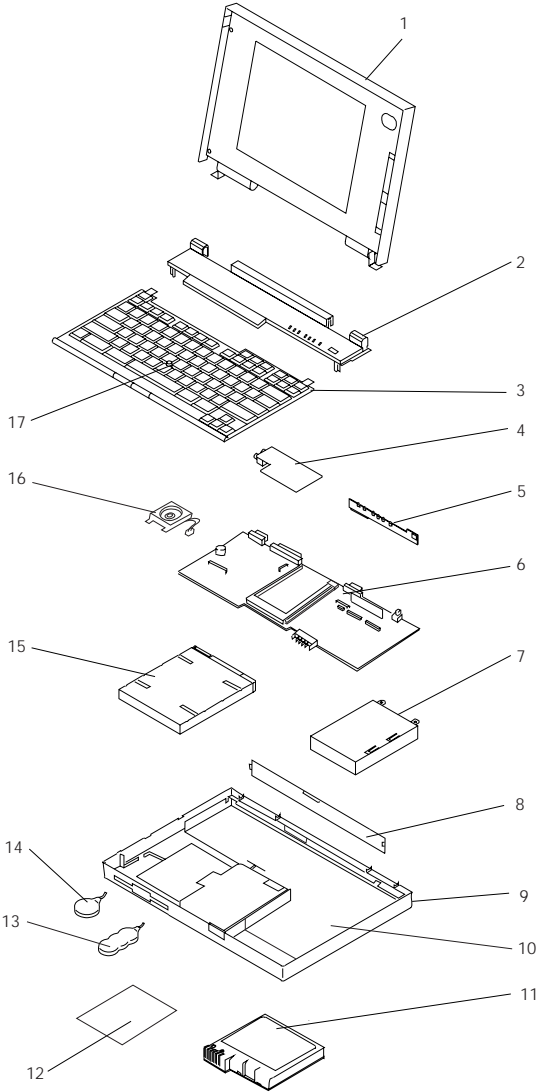

System Unit Models 340 and 340CSE

Index

1	LCD Assembly (340)	84G6678
1	LCD Assembly (340CSE)	
	9.4-inch	85G7601
	10.4-inch	85G7602
2	Top Cover (340)	84G6677
2	Top Cover (340CSE)	85G7600
3	Keyboard Assembly (See keyboard list)	
4	Modem/Fax Card (2400 bps.)	84G5917
5	Indicator Card	84G6662
6	System Board (340)	84G6661
6	System Board (25/50MHz)	
	With modem connector	85G7595
	Without modem connector	85G7596
6	System Board (33/66MHz)	85G7598
	Without modem connector	
7	125MB Hard Disk Drive	84G6663
	200MB Hard Disk Drive	85G7606
	360MB Hard Disk Drive	85G7608
8	Rear Connector Cover	84G6676
9	Base Cover Assembly (340)	84G6656
	For U.S.	84G6890
	For Japan	84G6659
	Base Cover Assembly (340CSE)	85G7612
	For U.S., Japan	85G7611
	Note: Base cover assembly includes coil spring, insulator, foot, power switch, knob, holder, latch buttons	
10	Shield Case	84G6660
11	Battery Pack (Nickel Cadmium)	84G6672
	For U.S.	84G6671
	For Japan	84G6674
11	Battery Pack (Nickel Metal Hydride)	85G7604
12	Accessory Cover	84G6675
13	Standby Battery	84G6668
	For U.S.	84G6667
	For Japan	84G6670
14	Backup Battery	84G6666
	Screw Kit (Includes the following)	84G6764
	10-2.5 x 4 mm; 10-2.5 x 6 mm	
	10-2.5 x 8 mm, Flat head;	
	10-2.5 x 8 mm; 10-2.5 x 16 mm	
	10-hex stud I/O; 10-hex stud bus	
	2-washers for hex stud bus	

DASD

Index

15	Diskette Drive (2-mode)	84G6664
	Diskette Drive (3-mode)	84G6665
16	Speaker (360CSE)	85G7643
17	TrackPoint II Cap	66G6444
17	TrackPoint III Cap	84G6536
	Shield Plate (340)	84G6774
	AC Adapter	84G6679
	For Japan	84G6738
	AC Adapter (small, 35W)	85G4952
	For Japan	85G6669
	DC Plug	85G6669
	IC DRAM Card (See options)	85G6664

Keyboards

Arabic	84G6881
Belgium	84G6879
Canadian French	84G6887
Danish	84G6878
Dutch	84G6876
Finnish, Swedish	84G6875
French	84G6872
German (Black)	84G6870
Greek	84G6885
Hebrew	84G6882
Italian	84G6874
Japanese	84G6888
Latin Spanish	84G6886
Norwegian	84G6880
Portuguese	84G6883
Spanish	84G6877
Swiss, French	84G6873
Swiss, German	84G6871
Turkish	84G6884
U.K. English	84G6869
U.S. English	84G6868

Option Parts List

Notes:

1. When you replace the AC Adapter with a new one, use the one for the country you are in even if the system is from a different country.
2. The warranty for the system unit does not apply to all options.

Basic IC DRAM CARD (no parity) 8MB	84G5725
Basic IC DRAM CARD (no parity) 4MB	84G5724
Basic IC DRAM CARD (no parity) 16MB	84G5726
Keyboard/Mouse Cable	54G0444
Microphone	66G7871
PS/2 Miniature Mouse	95F5723

Numeric Keypad

Belgian	95F5741
Canadian French	95F5466
Danish	95F5467
Dutch	95F5467
French	95F6313
German	95F6314
Greek	95F5467
Hebrew	95F5741
Icelandic	95F5467
Italian	95F6316
Japanese	79F6401
Norwegian	95F5467
Spanish	95F6315
Swedish/Finnish	95F5468
Swiss/French	95F5711
Swiss/German	95F5715
Turkish	95F5467
U.K. English	95F5741
U.S. English	95F5741

Tools

Tri-Connector Wrap Plug	72X8546
PC Test Card	35G4703
Audio Wrap Cable	66G5180
Screwdriver Kit	95F3598

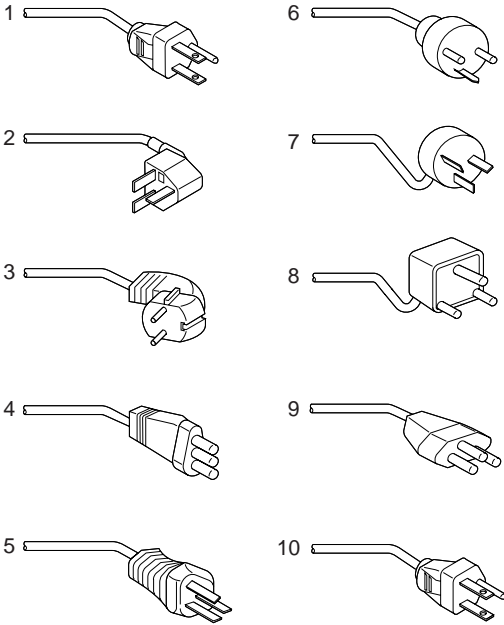

Warning: Use only the power cord certified for your country.

		30/40W	35W
1	Colombia, U.S., Venezuela	13F9959	25H2207
	Japan, 2-pin	6454377	85G6665
	Japan, 3-pin	65F0031	
2	Hong Kong, Singapore, U.K.	14F0033	25H2215
3	France, Germany, Spain	13F9979	25H2209
4	Italy	14F0069	25H2223
5	Australia, New Zealand	13F9940	25H2205
6	Denmark	13F9997	25H2211
7	Israel	14F0087	25H2225
8	Bangladesh, Pakistan, Sri Lanka, South Africa	14F0015	25H2213
9	Switzerland	14F0051	25H2221
10	Thailand	1838574	25H2219

Note: The 30/40W cord is 6 feet long; the 35W cord is 6 inches.

ThinkPad 700, 700C, 720, 720C (9552)

General Checkout	68
Memory Checkout	70
Power Systems Checkout	71
Power Management Features	81
Symptom-to-FRU Index	82
Numeric Error Codes	82
Beep Symptoms	88
Miscellaneous Symptoms	89
Undetermined Problem	93
Related Service Procedures	94
System Status Indicators	94
Check Point (CP) Codes	96
System Error Log	96
Checking the Installed Devices List	97
Power-On Password (700, 700C)	97
Power-On Password (720, 720C)	97
Privileged-Access Password (PAP)	97
Set Startup Sequence	98
Restore System Partition	98
Hard Disk Low Level Format	99
Replacing the Hard Disk Drive	99
System Diskettes (Reference and Diagnostic)	100
Making a System Partition Backup Copy	101
Japanese Model Diskette Drive and Diskette	102
173 and 11350 Error Combination	102
PCMCIA Card Removal Tip	102
Product Overview	102
FRU Removals and Replacements	104
Locations	110
Front View	110
System Board (700)	111
System Board (720, 720C)	112
Video Card	113
Keyboard Control Card	113
Voltage Converter	114
Parts Listing (700)	115
Parts Listing (720, 720C)	118
FRU Service Procedures	124

General Checkout

The diagnostic tests are intended to test *only* IBM products. Non-IBM products, prototype card, or modified options can give false errors and invalid system responses.

Warning: The drives might have been rearranged or the drive startup sequence might have been altered. Be extremely careful during write operations such as copying, saving, or formatting. Data or programs can be written over if you select an incorrect drive.

Japanese Models Only

The Japanese model of the ThinkPad 700C has an 89-key keyboard. This keyboard is identified by the additional keys at the left and right sides of the spacebar.

When testing the diskette drive in the Japanese model, the 1.2MB format (8 sectors per track and 15 sectors per track) in addition to the 720KB and 1.44MB formats are tested to ensure correct operation.

A 2.0MB capacity diskette is required when testing the 1.2MB format.

1. Power-off the computer and all external devices.
2. Check all cables and power cords for correct connection.
3. Make sure that no diskettes are in the drives.
4. Power-on all external devices.
5. Power-on the computer. If any error message appears on the screen, go to "Symptom-to-FRU Index" on page 82.

If no message appears on the screen, press **Ctrl+Alt+Delete** to continue. After the cursor moves to the upper right corner of the screen, press **Ctrl+Alt+Insert** to start the system program. If the IBM logo screen does not appear, insert the backup copy of the system partition into the diskette drive and start the system program again. Then press **Ctrl+A**, and run the system checkout. For information on how to disable the password, see "Power-On Password (700, 700C)" on page 97.

6. Refer to the following table. If you do not find your symptom listed, go to "Symptom-to-FRU Index" on page 82, then go to "Undetermined Problem" on page 93.

Symptom	Go to ...
Error Code or Message	"Symptom-to-FRU Index" on page 82
Configuration Problem	"Checking the Installed Devices List" on page 97
Power Problem	"Power Systems Checkout" on page 71
Memory Problem	"Memory Checkout" on page 70
TrackPoint II or Pointing Stick Problem	"TrackPoint II Checkout" on page 476
ThinkPad 700C, 720C Color LCD Problem	"LCD FRU Replacement Notice" on page 124
ThinkPad 700, 720 Mono Panel Problem	"700, 720 Mono LCD FRU Replacement" on page 124
High Speed Modem Noise Problem	"High-Speed Modem Noise Problems" on page 124

Note

For information about how to run diagnostics, error messages, passwords, and various other tests and service checks, go to "Related Service Procedures" on page 94.

Memory Checkout

Customer diagnostics can eliminate defective memory so no memory error message appears at power-on reset. After you replace a defective base memory card or IC DRAM card, run **Automatic configuration**. Otherwise, the new memory will not be recognized. Power-off the computer before you remove or replace any parts.

001

- Remove all IC DRAM cards from their slots (if installed).
- Power-off the computer, then power it on.
After the cursor moves to the upper right corner of the screen, press **Ctrl+Alt+Insert** to start the system program.
- Press **Ctrl+A** at the Main Menu.

DID THE ADVANCED DIAGNOSTIC MENU APPEAR?

Yes No

002

Replace the base memory card.
If the problem is not corrected, go to “Undetermined Problem” on page 93.

003

- Run the memory tests.
Use the RUN TESTS ONE TIME option.

DID THE MEMORY TESTS END WITHOUT AN ERROR?

Yes No

004

Replace the base memory card.

005

- Install the IC DRAM card into slot 1 and run **Automatic configuration**.
- Run the memory test.
Use the RUN TESTS ONE TIME option.

DID THE MEMORY TESTS END WITHOUT AN ERROR?

Yes No

006

Replace the IC DRAM card in slot 1.
If the problem is not corrected, replace the system board.

007

- Install the IC DRAM card into slot 2 and run **Automatic configuration**.
(Step **007** continues)

007 (continued)

- Run the memory test.
Use the RUN TESTS ONE TIME option.

DID THE MEMORY TESTS END WITHOUT AN ERROR?

Yes **No**

008

Replace the IC DRAM card in slot 2.
If the problem is not corrected, replace the system board.

009

If the problem occurs intermittently, run the memory tests multiple times to create an error log.

Power Systems Checkout

Note: One or all of the batteries can discharge if there is a short circuit in the system.

1. Replace the failing FRU if the power supply problem is caused by a short circuit.
2. Determine if one (or all) of the batteries have become discharged. Replace any discharged battery with its spare, if available.

The test procedures for each power supply are found on the following pages.

"Checking the AC Adapter" on page 72.
"Checking the Car Battery Adapter (700 only)" on page 73.
"Checking the Battery Pack" on page 74.
"Checking the Backup Battery" on page 75
"Checking the Standby Battery" on page 75.
"Checking the Quick Charger" on page 76.
"Checking the Voltage Converter (700, 700C)" on page 77.
"Checking the Voltage Converter (720, 720C)" on page 78.

Checking the AC Adapter: If the Power-On indicator does not turn-on, check the power cord of the AC adapter for correct continuity and installation.

1. If any noise can be heard from the AC adapter when it is plugged into the ac power outlet, replace the AC adapter.

If no noise can be heard from the AC adapter, go to step 3.

2. If a noise is still heard from the new AC adapter, suspect the computer. Replace the AC adapter with the original one, then go to the next step. If no noise is heard from the new AC adapter, the original AC adapter is defective.
3. Unplug the AC adapter cable from the computer and measure the output voltage at the plug of the AC adapter cable. See the following figure.

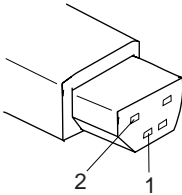

Pin	Voltage (V dc)
1	+19.0 to +21.0
2	Ground

- If the voltage is not correct, go to the next step.
4. Unplug the AC adapter cable from the ac power outlet and wait for a few minutes.
 5. Plug the AC adapter cable into the ac power outlet.
 6. Measure the output voltage of the AC adapter.
 - If the voltage is still not correct, replace the AC adapter.
 - If the voltage is correct, plug the AC adapter cable into the computer and try the failing operation again.
 - If the problem goes away, suspect the continuity or installation of the AC adapter cable.
 - If the problem is not corrected, replace the voltage converter.

Checking the Car Battery Adapter (700

only): If the output voltage from the cigarette lighter socket of the car is less than 10.5 V dc, the power-on indicator on the car battery adapter blinks and a noise can be heard continuously.

1. Unplug the car battery adapter cable from the connector, if connected.
2. Plug the car battery adapter into the cigarette lighter socket.

Note: If the adapter is already plugged in, be sure to unplug the adapter from the cigarette lighter socket, then plug it into the socket again.

3. Measure the output voltage of the car battery adapter cable. See the following figure.

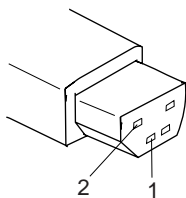

Pin	Voltage (V dc)
1	+19.0 to +21.0
2	Ground

- If the voltage is correct and the power-on indicator on the car battery adapter is on all the time, the car battery is working correctly. Replace the voltage converter. If the problem is not resolved when the voltage converter is replaced, go to “Checking the Voltage Converter (700, 700C)” on page 77 or “Checking the Voltage Converter (720, 720C)” on page 78.
- If the voltage is outside the normal voltage range, do one of the following:
 - Try the above test procedures using a different car, if one is available.
 - Replace the car battery adapter if the computer works with the AC adapter but does not work with the car battery adapter.

Note: If the output voltage from the cigarette lighter socket of the car is less than 10.5 V dc, the power-on indicator on the car battery adapter blinks and a continuous noise can be heard. Have the car battery serviced.

Checking the Battery Pack

1. Carefully place the computer bottom-side up.
2. Remove the battery pack and measure the voltage between the battery terminals 1 (+) and 3 (-). See the following figure.

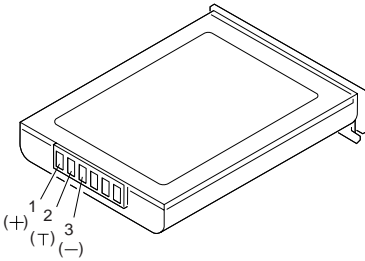

Pin	Voltage (V dc)
1	+10.0 to +18.0
2	Thermal Detection
3	Ground

- If the voltage is less than +10.0 V dc, the battery pack has been discharged or is defective.
 - If the voltage is more than +10.0 V dc, go to the next step.
3. Using an ohm meter, measure the resistance between battery terminals 2 (T) and 3 (-). The resistance must be 4 to 30 kilohms.
 - If the resistance is not correct, replace the battery pack.
 - If the resistance is correct, go to the next step.
 4. Install the battery pack and plug the AC adapter cable into the computer to charge the battery pack.
 - If the **battery power status** indicator is blinking (orange) and **battery charging** indicator is on, replace the battery pack. If the battery is charging normally, the battery is OK.

Checking the Backup Battery

1. Carefully place the computer bottom-side up.
2. Remove the bottom cover.
3. Disconnect the battery connector from the system board.
4. Measure the voltage of the backup battery. See the following figure.

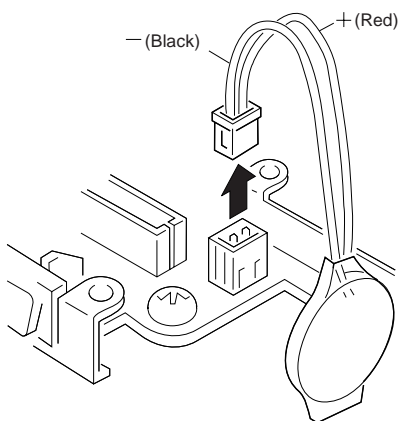

Wire	Voltage (V dc)
Red	+2.5 to +3.7
Black	Ground

- If the voltage is correct, replace the system board.
- If the voltage is not correct, the backup battery has been discharged by a short circuit or it is defective.

Checking the Standby Battery

Note: Make sure that the battery pack is removed from the computer before the standby battery is removed.

1. Power-off the computer and unplug the AC adapter cable from the computer.
2. Remove the battery pack.
3. Remove the indicator cover.
4. Disconnect the standby battery connector from the voltage converter.
5. Plug the AC adapter cable into the computer and power-on the computer.
6. Measure the output voltage at the connector on the voltage converter. See the following figure.

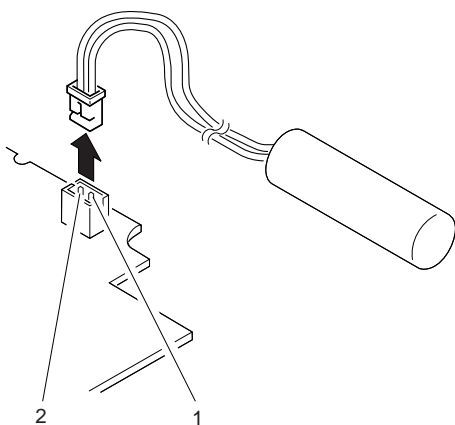

Pin	Voltage (V dc)
1	+4
2	Ground

- If the voltage is less than +4 V dc, replace the voltage converter.
 - If the voltage is more than +4 V dc, go to the next step.
7. Power-off the computer and unplug the AC adapter cable from the computer.
 8. Reconnect the standby battery to the voltage converter.
 9. Plug the AC adapter cable into the computer and power-on the computer. Allow approximately 30 minutes for the standby battery to charge.
 10. Power-off the computer and unplug the AC adapter cable from the computer and remove the standby battery.
 11. Measure the voltage of the standby battery.
 - If the voltage is less than 3.5 V dc, replace the standby battery.

Checking the Quick Charger: If a humming or buzzing sound is heard from the quick charger when it is operating, replace the quick charger. If the charger is operating at a normal quiet sound level, do the following.

1. Perform steps 1 through 3 of the “Checking the Battery Pack” to ensure the battery pack is operating correctly.
2. Connect the power cord to the quick charger and the other end to the ac power outlet. Ensure that the power-on indicator is on.
 - If the power-on indicator does not turn on, check the power cord of the quick charger for correct continuity and installation.

- If the problem is not corrected, replace the quick charger or the power cord.
3. Install the battery pack into the quick charger.
 - If the charging indicator does not start blinking, replace the quick charger.

Checking the Voltage Converter (700, 700C):

Use the following procedure to isolate a problem with the ThinkPad 700, 700C voltage converter.

Note: If the problem only occurs when using the computer with a good battery pack, replace the voltage converter.

1. Power-off the computer.
2. Power-off all attached devices and disconnect them from the computer.
3. Unplug the AC adapter cable and remove the battery pack from the computer.
4. Carefully place the computer bottom-side up and remove the bottom cover.
5. Plug the AC adapter cable into the computer.
6. Power-on the computer.

Important

Be careful not to actuate the suspend switch (located between the Esc key and the LCD) during the operation. When you turn the computer upside down with the LCD opened, put something under the computer to prevent accidentally actuating the suspend switch.

7. Check the voltages of the voltage converter on the system board. See the following figure.

Signal	V dc Min.	V dc Max.
VA	+4.75	+5.25
VG	+4.75	+5.25
VB	+4.75	+5.25
VC	+3.42	+3.78
PWRGOOD	+4.00	+5.25

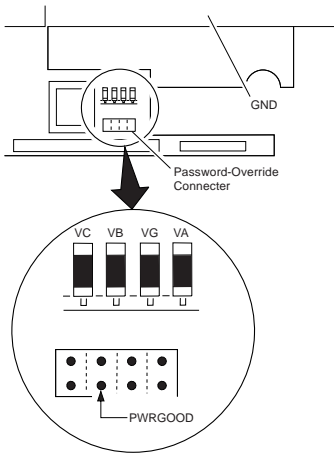

Note: Only VOLT is marked on the system board. Use the above figure to locate the VA, VG, VB, VC, and PWRGOOD signal names.

- If all voltages are correct, the voltage converter is operating correctly.
 - If the voltages are not correct, go to the next step.
8. Power-off the computer and unplug the AC adapter cable from the computer.
 9. Check for a short circuit between GND and VA, VG, VB, or VC.
 - If there is a short circuit, replace the following FRUs one at a time to correct the problem.
 - Voltage converter
 - System board
 - If there is no short circuit, go to the next step.
 10. Check the output voltage of the AC adapter cable (see “Checking the AC Adapter” on page 72).
 - If the output voltage is correct, go to the next step.
 11. Replace the following FRUs one at a time.
 - Voltage converter
 - System board

Checking the Voltage Converter (720, 720C):

Use the following procedure to isolate a problem with the ThinkPad 720, 720C voltage converter.

1. Power-off the computer.
2. Power-off all attached devices and disconnect them from the computer.
3. Unplug the AC adapter cable, then remove the battery pack from the computer.
4. Carefully place the computer bottom-side up and remove the bottom cover.
5. Plug the AC adapter cable into the computer.

6. Open the LCD half-way, then stand the computer on its front edges so that the suspend switch is not activated.
7. Power-on the computer.
8. Check the voltages of the voltage converter on the system board. See the following figure.

Notes:

- a. Make sure the suspend switch (located to the left above the keyboard) is not activated during measurement of the voltage.
- b. Only PG is marked on the system board. Use the following figure to locate the VA, VG, VB, VA3, and VB3 signal names.

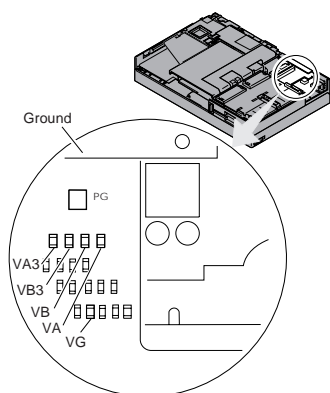

Signal	V dc Min.	V dc Max.
VA	+4.75	+5.25
VG	+4.75	+5.25
VB	+4.75	+5.25
VA3	+3.42	+3.78
VB3	+3.42	+3.78
PG	+4.00	+5.25

- If any voltage is not correct, go to step 9.
 - If all voltages are correct, the voltage converter is operating correctly. If the power problem did no reoccur, reconnect the devices removed in step 2 to isolate a device problem.
 - If all the voltages are correct and the power problem still exists, replace the following FRUs one by one.
 - System board
 - Processor card
9. Power-off the computer and unplug the AC adapter cable from the computer.
 10. Check for a short circuit between Ground and VA, VG, VB, VA3 or VB3. The following table shows which FRUs can cause a short at each signal.

- If there is a short circuit (less than 10 ohms), remove the FRUs indicated one at a time until the short circuit disappears. Replace the FRU causing the short circuit.

FRU	VA	VG	VB	VA3	VB3
Voltage converter	x	x	x	x	
Processor card			x		x
System board	x	x	x	x	x
Video card	x		x	x	x
Base memory card	x				
Keyboard control card	x		x		
Math coprocessor			x		x
Diskette drive			x		
Hard disk drive			x		
LCD	x				
Indicator assembly		x	x		

11. If there is no short circuit, replace the following FRUs one at a time.
- Voltage converter
 - System board

Power Management Features

The suspend and resume functions are unique methods used to save battery power. In suspend mode, all tasks are suspended and their present states are stored in memory to save power. Also, the system enters a *sleep* state where only a minimum amount of power is used.

When the computer returns to normal operation using the resume function, the computer restores the same states as when it entered suspend mode.

Full and Partial Suspend Modes: Suspend mode might be referred as full-suspend mode, as compared to partial-suspend mode.

The computer enters partial-suspend mode when an application software program interferes with the power management capability of the computer and prevents it from entering full-suspend mode. The following sounds indicate suspend mode has occurred:

- One beep for full-suspend mode
- Two beeps for partial-suspend mode

(No beep is heard if the *Power controller beep* parameter is set to off in the Set Advanced Features program.)

The computer enters suspend mode when:

- The LCD is closed (the switch is located on the voltage converter card).
- The specified time has elapsed from the last operation with the keyboard, mouse, hard disk drive, parallel connector, diskette drive, and AC adapter is plugged in. The time is specified by **System suspend** in the Set Advanced Features program.
- When a battery-low condition exists, the battery power indicator blinks (orange).
- The *PS2 OFF* command is set in the Set Advanced Features program.
- The operating temperature is exceeded.

The system returns to normal operation when:

- The LCD is opened.
- *PS2 ON HH:MM:SS* command was set in the Set Advanced Features program before entering suspend mode.
- A "Ring indicator" signal on the communication interface is detected.
- Either button of the pointing stick is pressed.

You can replace the battery pack during full-suspend mode. Never replace the battery pack during partial-suspend mode. If the battery pack is replaced during suspend mode with the LCD opened, close the LCD and open it again to return to normal operation.

Symptom-to-FRU Index

The Symptom-to-FRU Index lists error symptoms and possible causes. The most likely cause is listed first. Always begin with “General Checkout” on page 68. This index also can be used to help you decide which FRUs to have available when servicing a computer.

If you cannot correct the problem using this index, go to “Undetermined Problem” on page 93.

IMPORTANT:

1. If you have both an error message and an incorrect audio response, diagnose the error message first.
2. If you cannot run the advanced diagnostic tests, but did receive a POST error message, diagnose the POST error message.
3. If you did not receive an error message, look for a description of your error symptoms in this index.
4. Check all power supply voltages before you replace the system board. See “Power Systems Checkout” on page 71.
5. If an error message is not listed, there is a device installed that requires an additional diskette or service manual. Refer to the diskette or service manual for that device.

How to Read POST Error Messages

POST error messages are displayed on the screen as 3, 4, 5, or 8 digits. The error messages that can be displayed as shorter POST messages are highlighted in this Symptom-to-FRU Index.

Note: Adjust the speaker volume before you power-on the computer.

In the following error codes, an *X* can be any number.

Numeric Error Codes

Symptom/Error	FRU/Action
00010200, 00010300, 00010400, 00010700	1. System Board
00010800	1. System Board 2. Processor card
00011000	1. Go to “Memory Checkout” on page 70 before replacing any FRUs. 2. Base Memory Card 3. IC DRAM Card 4. System Board
000113XX	1. System Board 2. Processor Card

Symptom/Error	FRU/Action
000118XX	<ol style="list-style-type: none"> 1. Clear Error Log. See “System Error Log” on page 96. 2. If the error remains, replace the FRUs in the following order: <ul style="list-style-type: none"> • Base Memory Card • IC DRAM Card <p>Note: Error Log must be cleared when a FRU is replaced.</p>
00016100	<ol style="list-style-type: none"> 1. See “Checking the Backup Battery” on page 75. 2. System Board 3. Voltage Converter
00016300, 00016400, 00016500, 00016900 (If 00016300 appears, set date and time first in the Reference Diskette.) (If setting configuration does not solve the problem, see “Checking the Installed Devices List” on page 97.)	<ol style="list-style-type: none"> 1. Set Configuration/Features 2. System Board 3. Hard Disk Drive 4. Base Memory Card 5. IC DRAM Card
000171XX, 000172XX	<ol style="list-style-type: none"> 1. System Board
00017300 (700, 700C Only) Before replacing a FRU, restore the system partition with the Reference Diskette Version 1.1 or later. See “Installing a New Version of the System Diskettes” on page 100.	<ol style="list-style-type: none"> 1. See “173 and 11350 Error Combination” on page 102 before replacing FRUs. 2. See “Checking the Backup Battery” on page 75. 3. Voltage Converter
00017400 (If Automatic Configuration does not solve the problem, run Advanced Diagnostic.)	<ol style="list-style-type: none"> 1. Set Configuration/Features
000175XX, 00017700 00017800	<ol style="list-style-type: none"> 1. System Board
000179XX	<ol style="list-style-type: none"> 1. Run System Unit and Memory Diagnostic. - or - 2. Select More utilities to clear the system error log.
000183XX	<ol style="list-style-type: none"> 1. PAP (Privileged Access Password) is needed to boot from the System Program.
000184XX, 00018500	<ol style="list-style-type: none"> 1. System Board

Symptom/Error	FRU/Action
000187XX	<ol style="list-style-type: none"> 1. Set Configuration 2. System Board
000188XX	<ol style="list-style-type: none"> 1. System Board
000189XX	<ol style="list-style-type: none"> 1. Select More utilities to clear the system error log.
00019000	<ol style="list-style-type: none"> 1. Reseat System Board 2. Reseat CPU chip / Processor Card 3. System Board
00019102	<ol style="list-style-type: none"> 1. Rerun diagnostics tests. 2. If error remains, see 000191XX.
000191XX (Not listed above)	<ol style="list-style-type: none"> 1. Reseat System Board 2. Reseat CPU chip / Processor Card 3. System Board
00019200	<ol style="list-style-type: none"> 1. Voltage Converter 2. Keyboard Control Card 3. System Board
00019201	<ol style="list-style-type: none"> 1. Voltage Converter
00019202	<ol style="list-style-type: none"> 1. Run System Unit Diagnostic. If this error message appears frequently, replace the Processor Card.
00019300, 00019301 00019305	<ol style="list-style-type: none"> 1. System Board
00019302	<ol style="list-style-type: none"> 1. Hard Disk Drive 2. System Board
00019303	<ol style="list-style-type: none"> 1. System Board 2. Diskette Drive
00019304	<ol style="list-style-type: none"> 1. PC Card 2. System Board
00019306	<ol style="list-style-type: none"> 1. Keyboard Control Card 2. Keyboard 3. Pointing Device
00019400	<ol style="list-style-type: none"> 1. Processor Card
000199XX	<ol style="list-style-type: none"> 1. System Board
0001XXXX (not listed above)	<ol style="list-style-type: none"> 1. System Board 2. Processor Card
000215XX (720, 720C only)	<ol style="list-style-type: none"> 1. Reseat Base Memory Card (interface connector on system board).

Symptom/Error	FRU/Action
0002XXXX (See "Memory Checkout" on page 70 before replacing any FRUs.)	<ol style="list-style-type: none"> 1. Base Memory Card 2. IC DRAM Card 3. System Board
00030100, 00030500 (Power-on the computer before external devices.) (See "1080 Keyboard Unit" on page 54 before replacing any FRUs.)	<ol style="list-style-type: none"> 1. Keyboard Control Card 2. System Board 3. Keyboard 4. Numeric Keypad or Keyboard/Mouse Cable (if attached) or External Keyboard (if attached)
00030200, 00030300, 00030400 (See "1080 Keyboard Unit" on page 54 before replacing any FRUs.)	<ol style="list-style-type: none"> 1. System Board 2. Keyboard Control Card 3. Keyboard 4. Numeric Keypad or Keyboard/Mouse Cable (if attached) or External Keyboard (if attached)
00030600 (See "1080 Keyboard Unit" on page 54 before replacing any FRUs.)	<ol style="list-style-type: none"> 1. Keyboard 2. Numeric Keypad or Keyboard/Mouse Cable or External Keyboard (if attached) 3. Keyboard Control Card 4. System Board
00030700	<ol style="list-style-type: none"> 1. External Keyboard 2. Keyboard/Mouse Cable
0004XXXX	<ol style="list-style-type: none"> 1. System Board 2. Any Parallel Device 3. Communication Cable
000601XX	<ol style="list-style-type: none"> 1. Diskette Drive 2. System Board 3. Diskette Drive Cable
000602XX	<ol style="list-style-type: none"> 1. Defective Diskette
000628XX	<ol style="list-style-type: none"> 1. Incorrect Diskette Media Type 2. Diskette Drive 3. System Board 4. Diskette Drive Cable
000655XX, 000662XX 000670XX - 000675XX	<ol style="list-style-type: none"> 1. System Board 2. Diskette Drive 3. Diskette Drive Cable
0006XXXX (Unsupported drive or cable)	<ol style="list-style-type: none"> 1. Diskette Drive 2. System Board 3. Diskette Drive Cable
0007XXXX	<ol style="list-style-type: none"> 1. Math Coprocessor 2. Processor Card
0011XX00	<ol style="list-style-type: none"> 1. System Board 2. Any Serial Device 3. Communication Cable

Symptom/Error	FRU/Action
0014XXXX	<ol style="list-style-type: none"> 1. See "Printer Checkout" on page 474 before replacing any FRUs. 2. Printer 3. System Board
00180100, 00186100	<p>Replace the line QEMM386.SYS with QEMM386.SYS XBDA:L in Config.sys.</p>
0024XX00	<ol style="list-style-type: none"> 1. Video Card 2. System Board 3. Voltage Converter (700C, 720C only)
0039G900	<ol style="list-style-type: none"> 1. System Board
005002XX, 005006XX, 005008XX, 005041XX	<ol style="list-style-type: none"> 1. See "External Display Self-Test" on page 470 before replacing any FRUs. 2. Video Card 3. External Display 4. LCD 5. System Board
005004XX, 005010XX, 005030XX - 005032XX, 005051XX - 005062XX	<ol style="list-style-type: none"> 1. Video Card 2. System Board 3. LCD
005009XX, 005040XX	<ol style="list-style-type: none"> 1. See "External Display Self-Test" on page 470 before replacing any FRUs. 2. External Display 3. Video Card 4. System Board
0080XXXX	<ol style="list-style-type: none"> 1. System Board 2. PCMCIA Card Slot
0085XXXX	<ol style="list-style-type: none"> 1. Do not replace any FRUs. The installed Memory Expansion Adapter is not supported by IBM.
00860100, 00860200 See "1080 Keyboard Unit" on page 54 before replacing any FRUs.	<ol style="list-style-type: none"> 1. Pointing Device 2. System Board 3. Numeric Keypad
00860300, 00860400 00862300, 00862400 See "1080 Keyboard Unit" on page 54 before replacing any FRUs.	<ol style="list-style-type: none"> 1. System Board 2. Keyboard Control Card 3. Pointing Device 4. Keyboard (TrackPoint) 5. Numeric Keypad

Symptom/Error	FRU/Action
00861100, 00861200 00861300 See "1080 Keyboard Unit" on page 54 before replacing any FRUs.	<ol style="list-style-type: none"> 1. Keyboard Control Card 2. Keyboard (Pointing Stick) 3. System Board 4. Ext. Keyboard Cable
00861XXX (not listed above) See "1080 Keyboard Unit" on page 54 before replacing any FRUs.	<ol style="list-style-type: none"> 1. Keyboard (Pointing Stick) 2. Keyboard Control Card 3. System Board
00862100, 00862200 See "1080 Keyboard Unit" on page 54 before replacing any FRUs.	<ol style="list-style-type: none"> 1. Keyboard Control Card 2. System Board 3. Keyboard (TrackPoint)
00862500, 00862600 See "1080 Keyboard Unit" on page 54 before replacing any FRUs.	<ol style="list-style-type: none"> 1. Keyboard (Pointing Stick) 2. Keyboard (TrackPoint) 3. Keyboard Control Card
0086XX00 See "1080 Keyboard Unit" on page 54 before replacing any FRUs.	<ol style="list-style-type: none"> 1. Keyboard Control Card 2. Keyboard 3. System Board
010103XX - 010110XX, 010116XX - 010153XX, 010171XX	<ol style="list-style-type: none"> 1. See "Fax/Modem Checkout" on page 472.
010436XX	<ol style="list-style-type: none"> 1. System Board 2. Hard Disk Drive
0104XXXX	<ol style="list-style-type: none"> 1. Hard Disk Drive 2. System Board
0129XXXX	<ol style="list-style-type: none"> 1. Run System Board diagnostics to clear the error log and retest 2. Select N to the question during the System Board diagnostics. 3. Power-on the system. If the error remains, replace the Processor Card. 4. Repeat steps 1 and 2. 5. If the problem remains, replace the system board.
0130XXXX	<ol style="list-style-type: none"> 1. Indicator Assembly 2. System Board 3. Keyboard Control Card 4. Hard Disk Drive 5. Diskette Drive 6. Diskette Drive Cable 7. Speaker

Symptom/Error	FRU/Action
0137XXXX	<ol style="list-style-type: none"> 1. Serial Adapter 2. System Board 3. Video Card 4. Any Serial Device 5. Communication Cable
0194XXXX	<ol style="list-style-type: none"> 1. Do not replace any FRUs. The installed Memory Expansion Adapter is not supported by IBM.
199903XX, 199900XX 199800XX	<ol style="list-style-type: none"> 1. Reseat the hard disk drive to ensure good connection. 2. See "Set Startup Sequence" on page 98. 3. Hard Disk Drive 4. System Board
1999XXXX	Restore the system partition from the Reference Diskette.

Beep Symptoms

Symptom/Error	FRU/Action
Continuous beep.	System Board
Repeating short beeps.	<ol style="list-style-type: none"> 1. See "1080 Keyboard Unit" on page 54 before replacing any FRUs. 2. Keyboard 3. Keyboard Control Card 4. System Board
One long and one short beep.	<ol style="list-style-type: none"> 1. System Board
One long and two short beeps.	<ol style="list-style-type: none"> 1. Video Card 2. System Board
One short beep and a blank, unreadable, illegible, or flashing display with no external display attached.	<ol style="list-style-type: none"> 1. LCD 2. Video Card 3. System Board 4. Voltage Converter
One short beep and a diskette prompt or a program load from the hard disk or unable to read the diskette. (Be sure an external display is not too close to the diskette drive.)	<ol style="list-style-type: none"> 1. Diskette Drive 2. System Board 3. Diskette Drive Cable
Two short beeps and a blank display.	<ol style="list-style-type: none"> 1. System Board

Symptom/Error	FRU/Action
Two long beeps and two short beeps (or two long beeps and no short beeps). (Possibly with a blank screen and blinking speaker icon.)	<ol style="list-style-type: none"> 1. Video Card 2. Incorrect system board (700, 700C) 3. Incorrect processor upgrade (700, 700C) 4. Incorrect 240MB hard disk drive upgrade for this model

Miscellaneous Symptoms

Symptom/Error	FRU/Action
Power-on password is not reactivated.	<ol style="list-style-type: none"> 1. Check the power-on password switch position.
Problem occurs only when port replicator installed.	<ol style="list-style-type: none"> 1. Port Replicator
No beep and a blank or unreadable display during POST.	<ol style="list-style-type: none"> 1. See “Power Systems Checkout” on page 71 before replacing any FRUs. 2. Processor Card 3. System Board 4. Video Card 5. Hard Disk Drive 6. Base Memory Card 7. Any option or device 8. Power source in use when failure occurs 9. Voltage Converter 10. Speaker
No beep with a blinking cursor.	<ol style="list-style-type: none"> 1. System Board 2. Processor Card 3. Any Option or Device
No beep with a normal display during POST.	<ol style="list-style-type: none"> 1. Speaker 2. System Board 3. Keyboard Control Card 4. Voltage Converter
No beep and the system hangs with CP XX at the right-bottom corner of the screen.	<ol style="list-style-type: none"> 1. System Board 2. Processor Card
No beep and the system hangs after displaying the memory count.	<ol style="list-style-type: none"> 1. System Board 2. Processor Card 3. Hard Disk Drive 4. Coprocessor
No boot with blank screen.	<ol style="list-style-type: none"> 1. System Board
Extra horizontal or vertical lines displayed on upper or lower half of the LCD.	<ol style="list-style-type: none"> 1. LCD 2. Video Card 3. System Board

Symptom/Error	FRU/Action
LCD screen unreadable or characters missing pels.	<ol style="list-style-type: none"> 1. See important note for “LCD FRU Replacement Notice” on page 124. 2. LCD Assembly 3. System Board
LCD too dark, unable to adjust contrast or brightness.	<ol style="list-style-type: none"> 1. LCD 2. Video Card
LCD slightly dims when changing to battery power.	<ol style="list-style-type: none"> 1. Normal operation (Dimming of LCD conserves battery power.)
LCD unreadable, illegible, or distorted.	<ol style="list-style-type: none"> 1. LCD 2. Video Card 3. System Board
LCD cannot be powered-on or off.	<ol style="list-style-type: none"> 1. Video Card 2. System Board 3. Voltage Converter
Blank screen, or extra horizontal or vertical lines displayed on upper or lower half of the LCD with no beep or one short beep.	<ol style="list-style-type: none"> 1. LCD 2. Video Card 3. System Board
System status indicator is incorrectly blinking or stays on.	<ol style="list-style-type: none"> 1. System Board 2. Related Device 3. Indicator Assembly
System status indicator stays off, but the POST ends without an error.	<ol style="list-style-type: none"> 1. System Board 2. Related Device 3. Indicator Assembly
No keys on the keyboard work. See “1080 Keyboard Unit” on page 54.	<ol style="list-style-type: none"> 1. Keyboard Control Card 2. Keyboard 3. External Keyboard or Numeric Keypad (if attached) 4. System Board
Keypad problems.	<ol style="list-style-type: none"> 1. Reseat cable 2. External Keypad 3. Keyboard Control Card 4. System Board
One or more keys do not work.	<ol style="list-style-type: none"> 1. See “1080 Keyboard Unit” on page 54 before replacing any FRUs. 2. Keyboard 3. External Keyboard or Numeric Keypad (if attached) 4. Keyboard Control Card

Symptom/Error	FRU/Action
Mouse and Pointing Stick problems.	<ol style="list-style-type: none"> 1. See “1080 Keyboard Unit” on page 54 before replacing any FRUs. 2. Disable Trackpoint and test Mouse again. The Trackpoint can interfere with the operation of some Mouse devices. 3. Mouse 4. Keyboard Control Card 5. Keyboard
Cursor floats or moves erratically.	<ol style="list-style-type: none"> 1. See “TrackPoint II Checkout” on page 476 before replacing any FRUs. 2. Mouse 3. Keyboard
External display problems.	<ol style="list-style-type: none"> 1. See “External Display Self-Test” on page 470 before replacing any FRUs. 2. External Display 3. Video Card 4. System Board
Incorrect memory size during POST.	<ol style="list-style-type: none"> 1. See “Memory Checkout” on page 70 before replacing any FRUs. 2. Base Memory Card 3. IC DRAM Card
System hang or Intermittent hang.	<ol style="list-style-type: none"> 1. See “Undetermined Problem” on page 93 before replacing any FRUs. 2. System Board 3. Hard Disk Drive 4. Replace the last device being tested 5. Voltage Converter
The system goes into suspend mode after the POST.	<ol style="list-style-type: none"> 1. System Board 2. Voltage Converter 3. Keyboard Control Card
The system does not suspend or resume.	<ol style="list-style-type: none"> 1. Check the Suspend/Resume switch operation. If broken, replace the Voltage Converter. 2. System Board 3. Voltage Converter 4. Keyboard Control Card 5. Keyboard
The computer does not power-off.	<ol style="list-style-type: none"> 1. Voltage Converter 2. System Board

Symptom/Error	FRU/Action
Real-time clock inaccurate.	<ol style="list-style-type: none"> 1. See “Checking the Backup Battery” on page 75 before replacing any FRUs. 2. Backup Battery 3. System Board
Printer problems.	<ol style="list-style-type: none"> 1. See “Printer Checkout” on page 474
Serial or serial port device problems.	<ol style="list-style-type: none"> 1. Device 2. Cable 3. Serial Adapter (if attached) 4. System Board
Parallel or parallel port device problems.	<ol style="list-style-type: none"> 1. Device/printer 2. Cable 3. Parallel Adapter (if attached) 4. System Board
Internal Data/Fax modem does not communicate with a remote modem or a facsimile machine.	<ol style="list-style-type: none"> 1. See “Fax/Modem Checkout” on page 472
PS2 command cannot power-off internal modem unless computer is powered-off.	<ol style="list-style-type: none"> 1. Create new PS2 setup program using UINSTALL command. (Reference Diskette must be 1.10 or later.)

Undetermined Problem

You are here because the diagnostic tests did not identify which adapter or device failed, the Devices List is incorrect or the system is inoperative. Follow the procedures below (do not isolate FRUs that are known to be good).

Check the power supply that was being used at the time of the failure. (See "Power Systems Checkout" on page 71.) If the power supply is operating correctly, continue with the following procedure.

1. Power-off the computer.
2. Remove or disconnect one of the following devices or adapter. (Do not isolate FRUs that are known to be good.)
 - a. Non-IBM devices
 - b. Modem, PC card, printer, mouse, or other external devices
 - c. Battery pack
 - d. Hard disk drive (removable disk drive)
 - e. IC DRAM card
 - f. Any adapter or device

Note: Replacing the hard disk drive, an IC DRAM card, or any adapter or device, might cause configuration errors.

3. Power-on the computer.
4. If the problem is not corrected, repeat steps 1 through 3 until you find the failing FRU or until all FRUs have been removed.
5. If all of the FRUs listed have been removed and the problem is not corrected, replace the following FRUs:
 - System board
 - Processor card
 - Video card









Related Service Procedures

This section provides information on the following:

"System Status Indicators"
"Check Point (CP) Codes" on page 96
"System Error Log" on page 96
"Checking the Installed Devices List" on page 97
"Power-On Password (700, 700C)" on page 97
"Power-On Password (720, 720C)" on page 97
"Privileged-Access Password (PAP)" on page 97
"Set Startup Sequence" on page 98
"Restore System Partition" on page 98
"Hard Disk Low Level Format" on page 99
"Replacing the Hard Disk Drive" on page 99
"System Diskettes (Reference and Diagnostic)" on page 100
"Making a System Partition Backup Copy" on page 101
"Japanese Model Diskette Drive and Diskette" on page 102
"173 and 11350 Error Combination" on page 102
"PCMCIA Card Removal Tip" on page 102

System Status Indicators

Symbol	State	Status Indicated
	On	Speaker is enabled

Symbol	State	Status Indicated
	Green	Battery pack is fully-charged.
	Yellow	Battery pack is half-charged.
	Orange	Battery pack is one-fourth charged.
	Blinking Orange	Battery pack is almost discharged (replace with fully charged spare).
	Off	<ul style="list-style-type: none"> • Battery pack is completely discharged. • Battery pack is removed from computer. • Computer is off. • Computer is using external power; car battery or AC power.
	On	Battery is charging
	Off	Battery is full
	On	PC Card is in-use
	On	Diskette drive is active
	On	Hard disk drive is active
	On	Keyboard is in Num Lock mode
	On	Keyboard is in Caps Lock mode
	On	Keyboard is in Scroll Lock mode
	On	Computer is in Suspend Mode
	Blinking	Computer is resuming normal operation

Symbol	State	Status Indicated
①	On	Computer is powered-on (blinking indicates temperature too high - system enters suspend mode until temperature returns to normal).

Check Point (CP) Codes

Codes beginning with "CP" are displayed on the LCD to indicate system status during POST. The CP codes vary with the level of microcode installed and the type of processor card installed. The CP codes are not error codes. If the system detects an error, the CP code is changed to a POST error message.

System Error Log

The computer system maintains a system error log. The BIOS nonmaskable interrupt (NMI) handler writes an entry to the error log each time the system detects an error.

Viewing the error log: To view the error log, start the system programs and select **More utilities** from the Main Menu, then select **Display system error log**. For any error that is displayed, help screens guide you through the actions to take.

Error Storage: The error log stores up to three *unique* errors (for example three parity errors at three different addresses). The multiple log counter (on the screen) displays the number of times each unique error occurred. You can page forward by pressing F8, or backward by pressing F7 to view the stored error logs. The date and time of the most recent occurrence also is displayed. If the POST finds that the error log has stored three unique errors, the POST displays a 000179XX error.

Note: If the system configuration is changed, the system clears any logged errors associated with the FRU that was changed. (For example, if the memory configuration was changed, memory errors are cleared from the error log). The conditions under which errors are cleared vary with the type of hardware and level of microcode installed.

Application: If the system diagnostics run error-free, but you still suspect a problem, look at the error log. If errors were detected, press the F1 key and follow the

instructions on the screen to help you determine which FRU might be causing the failure.

Checking the Installed Devices List

The Installed Devices List shows the adapters and devices installed in the computer.

If an adapter or a device is missing from the list, one of the following conditions might be the cause.

Warning: A customized setup configuration (other than default settings) might exist on the system you are servicing. Running Automatic Configuration can alter the settings. Note the current configuration settings (using the **View configuration**) and verify that the same settings are in place when service is complete.

- The protected partition on the hard disk or the Reference Diskette you are using does not contain the code required to support the device.
- An adapter or device is defective.
- The device missing from the list is not recognized as a device or adapter.
- The device missing from the list requires an additional diskette. (See the device service manual.)
- A power supply voltage is not correct (see "Power Systems Checkout" on page 71).

If the adapter is on the list, run the adapter diagnostic tests.

If the list contains an adapter or device that is not installed, go to "Undetermined Problem" on page 93.

Power-On Password (700, 700C)

Important

This information is not available in this HMM online format. See your IBM Servicer or IBM Authorized Dealer for this procedure.

Power-On Password (720, 720C)

Important

This information is not available in this HMM online format. See your IBM Servicer or IBM Authorized Dealer for this procedure.

Privileged-Access Password (PAP)

This is an option. If a PAP is set, the computer cannot start and you have to get the customer to unlock the PAP. If the PAP is set, then forgotten, it cannot be overridden or removed. The system board must be replaced.

Set Startup Sequence

1. Power-off the computer.
2. Insert the backup copy of the Reference Diskette into the diskette drive.
3. Power-on the computer.
4. Select **Set features** from the Main Menu.
5. Select **Set startup sequence**. If you cannot set the startup sequence, replace the system board.
6. Check the list of devices on the **Set startup sequence** screen.
7. Is the hard disk drive in the list as a startup device?
Yes Exit from this screen and the Main Menu. Remove the backup copy of the Reference Diskette, and power-off the computer. Continue with step 8.
No Add the hard disk drive as a startup device.
8. Is an operating system installed?
Yes Go to step 10.
No Install the operating system.
9. After the operating system is installed, power-off the computer.
10. Power-on the computer.

Note: After the programs have been restored, the Diskette and F1 prompts appear, unless an operating system is present.

Restore System Partition

If the above sequence does not correct the problem, do the following:

1. Power-off the computer.
2. Insert the backup copy of the Reference Diskette into the diskette drive.
3. Power-on the computer.
Note: If the I99900X5 error message appears, the power-on password has been set. To disable the power-on password (see "Power-On Password (700, 700C)" on page 97) before continuing with the next step.
4. Select **Backup/Restore system programs** from the Main Menu, then select **Restore the System Partition**.
5. When the restore process completes, select **Set configuration**, then select **Run automatic configuration**.
6. Power-off the computer and remove the backup copy of the Reference Diskette from the diskette drive.
7. Power-on the computer.

Hard Disk Low Level Format

To format the hard disk and restore the system partition, do the following.

Warning: The following procedure causes permanent loss of the data on the hard disk. Make sure that a backup of all the information on the hard disk is made.

1. Power-off the computer.
2. Insert the backup copy of the Reference Diskette into the diskette drive.
3. Power-on the computer.
4. Proceed to the Main Menu. Press **Ctrl+A** to display the Advanced Diagnostic Menu.
5. Select **Format the hard disk** and follow the instructions on the screen to perform a low level format of the hard disk.
6. After the hard disk format is completed, power-off the computer.
7. Restore the system partition.
8. Reinstall the operating system.

Replacing the Hard Disk Drive

If you replace the internal hard disk drive, you must recopy all of the system programs onto the replacement hard disk drive. To recopy the programs:

1. Start the system using the customer's backup copy of the system partition.
2. Select **Backup/Restore system programs** from the Main Menu.
3. Run **Restore the system partition** to load the IML image, the system programs, and the diagnostic programs onto the hard disk drive just installed.

Notes:

- a. If there is not a backup copy of the system partition, make one before replacing the hard disk drive. (See "Making a System Partition Backup Copy" on page 101.)
- b. If the customer's backup copy of the system partition is incomplete, you cannot restore the whole system partition. If this occurs, after you have recopied the IML image, get the option diskettes and use **Copy an option diskette** to recopy the option files onto the system partition.
- c. If the IML image is loaded onto the hard disk drive, but the customer's operating system has not been loaded, the insert diskette icon will appear on the screen.

System Diskettes (Reference and Diagnostic)

If the hard disk drive is not operational, you can run the system programs from the Reference Diskette.

Note: The Reference Diskette contains the system programs and the Diagnostic Diskette contains the test programs. The Diagnostic Diskette is not self-starting. To run the Diagnostic Diskette, start the system from the Reference Diskette, select **Test the computer**, then follow the instructions on the screen.

Installing a New Version of the System

Diskettes: When you install the new system diskettes onto the hard disk, *all* existing files (including option files) in the system partition are written over. The new system diskettes provide the new system programs but they do not contain the option files; therefore, after completing the following process, you must reinstall the option files.

There are two methods to reinstall the option files.

1. From a backup copy of the current system partition. (this is the easiest way to reinstall the option files). For instructions on making a backup copy, see "Making a System Partition Backup Copy" on page 101.
2. From the original option diskettes.

Do the following for both methods.

1. Insert the new version of the Reference Diskette into the diskette drive.
2. Power-off the computer, then power it on. After the cursor moves to the upper right corner of the screen, press **Ctrl+Alt +Insert**.

Warning: This process writes over *all* existing files in the system partition. Before continuing, you *must* have either a backup copy of the current system partition or all the option diskettes so you can reinstall the option files.

3. Go to the Main Menu of the Reference Diskette and select **Backup/Restore system programs**, then select **Restore the system partition** and follow the instructions on the screen. This transfers all files, programs, and the IML image of the new diskette onto the system partition.
4. When the Main Menu appears again, remove the diskette from the diskette drive and power-off the computer, then power it on.
5. After the cursor moves to the upper right corner of the screen, press **Ctrl+Alt+Insert**.
6. If you have a backup copy of the current system partition, continue with step 7 on page 101. If you *do*

not have a backup copy of the current system partition, but you have the option diskettes, go to step 8 on page 101.

7. Select **Copy an option diskette** from the Main Menu. When the
INSERT YOUR OPTION DISKETTE
message appears, insert the backup copy of the system partition and follow the instructions on the screen. (The backup copy of the system partition is used to reinstall the option files onto the system partition.) Then go to step 9.
8. Select **Copy an option diskette** and follow the instructions on the screen. Repeat the procedure with each option diskette until all option diskettes have been reinstalled.
9. If there *is* a customized configuration installed (settings have been changed via the “Change configuration” screen), continue with step 10. If there *is not* a customized configuration installed, go to step 11.
10. Select **Set configuration** from the Main Menu. When you exit from **Set configuration** by pressing the **F3**, the customized configuration files will be restored onto the system partition as files @CMOS and @NVRAM.

Warning: Do not run **Run automatic configuration** now or you will write over the customized configuration.

11. You are finished with the updating process. Make a *new* backup copy of the system partition. (For information on making a backup copy, see “Making a System Partition Backup Copy.”)

Making a System Partition Backup Copy

Note: You might need two blank 2.0MB diskettes (or the old backup copy).

1. Power-off the computer, then power it on.
2. After the cursor moves to the upper right corner of the screen, press **Ctrl+Alt+Insert**.
3. When the Main Menu appears, select **Backup/Restore system programs**, then select **Backup the system partition**.
4. Insert a blank 2.0MB diskette into the diskette drive and follow the instructions on the screen.

Note: If you receive a message indicating that the diskette is full, and you are not prompted to insert a second diskette, this means that you will not be able to make a backup copy of the entire system partition. The user should keep the system diskettes and option diskette as a backup of these files.

5. When the copies are completed, label each diskette.

Japanese Model Diskette Drive and Diskette

The ThinkPad 700 uses a 1.44MB diskette drive. Both 1.0MB (formatted 720KB) and 2.0MB (formatted 1.44MB) capacity diskettes can be used in this drive.

The ThinkPad 700 Japanese model uses a diskette drive that supports 1.2MB format on 2.0MB capacity diskettes. When servicing a Japanese model, you must test all three formats.

Notes:

1. The ThinkPad 700C Japanese model has an 89-key keyboard. This keyboard is identified by the additional keys at the left and right sides of the spacebar.
2. A 2.0MB capacity diskette is required when testing the 1.2MB format.

173 and 11350 Error Combination

If a POST error combination of 00017300 and 11350 appears and cannot be bypassed, do the following before replacing any FRUs.

1. Power-off the computer.
2. Remove the hard disk drive from the computer.
3. Insert the Reference Diskette and power-on the computer.
4. Ignore any error messages, press **Esc**, **F8**, and **Enter**, then run Automatic Configuration.
5. Ignore the message "An error occurred while updating config" and power-off the computer.
6. Install the hard disk drive.
7. Keep the Reference Diskette in drive A and power-on the computer.
8. Ignore any error messages, press **Y**, and run Automatic Configuration.

PCMCIA Card Removal Tip

For the Model 720x, you can insert or remove the PCMCIA card during most computer operations. However, do not remove the card when the PC Card in-use light is on.

Product Overview

The following table provides a brief overview of the system features.

Feature	Description
Processor (700, 700C)	486SLC 25-MHz

Feature	Description
Processor (720, 720C)	486SLC 25/50-MHz
Bus Architecture	Micro Channel
Memory (Standard)	4MB
Memory (Maximum)	16MB, IC DRAM
CMOS RAM	8KB
Video	VGA
Diskette Drive	3.5-inch
Hard Drive	<ul style="list-style-type: none"> • 80MB, 2.5-inch • 120MB, 2.5-inch • 160MB, 2.5-inch
Audio Subsystem	Yes (Standard)
PCMCIA (720, 720C only)	One Type-III or Two Type-II

FRU Removals and Replacements

Follow the numerical sequence in the FRU removal sequence list and in the exploded view to remove or disconnect parts in the correct order. The letters in parentheses in the list indicate screw types. See the "Screw Size Chart" on page 20 to match the letters to the correct screw type and size before replacing each screw.

Safety Notice 8: Translation on page 13

Before removing any FRU, power-off the computer, unplug all power cords from electrical outlets, remove the battery pack, then disconnect any interconnecting cables.

- 1 Battery Pack**
(Press down and pull out)
- 2 LED Indicator Cover**
(Insert front first, then press rear down.)
- 3 Video Connector**
- 4 Video Power**
- 5 Hinge Covers**
(Install with bevelled edge at front.)
- 6 Two Screws (C)**
(One at each end)
- 7 Four Screws (S)**
(Two at each end)
- 8 LED Indicator Assembly**
(With connector and contact shield)
Lift LCD Assembly from computer
Place computer bottom-side up
- 9 Three Screws (S)**
(On bottom cover; two at front-right, one at rear of math coprocessor access door.)
- 10 Two Memory Bracket Screws (S)**
- 11 Five Screws (4-E, 1-V)**
(From processor card and video card)
- 12 Memory Module**
- 13 Ribbon Cable**
(At rear of diskette drive)
- 14 Diskette Drive**
(Hold the eject button pressed while installing.)
(Make sure the flexible cable gets into the holder plate opening on the IC DRAM card.)
- 15 Hard Disk Drive**
(Have the customer backup all information before replacing the drive. Never replace the hard disk drive when the system is operating or in suspend)

mode. Restore drive system information using the customer's backup copy of the system programs.)

16 Three Keyboard Frame Screws (S)

17 Two Screws (T)

18 System Board
(Restore system configuration data.)

19 Five Frame Stiffener Screws (S)

20 Frame Stiffener

21 Four Keyboard Screws (S)

22 Keyboard

23 One Screw (S) and Keyboard Control Card

24 Two Screws (R) and Voltage Converter with Suspend Resume Pin

(Set the lever on the voltage converter to the middle position before installation. Be sure the suspend pin is installed correctly before installing the voltage converter.)

ThinkPad 700 Exploded View

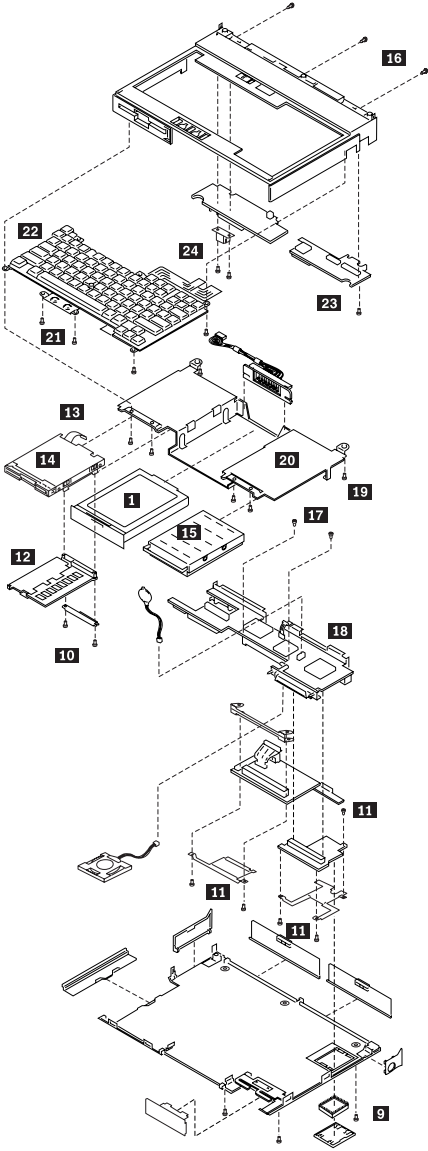

ThinkPad 700 Exploded View (continued)

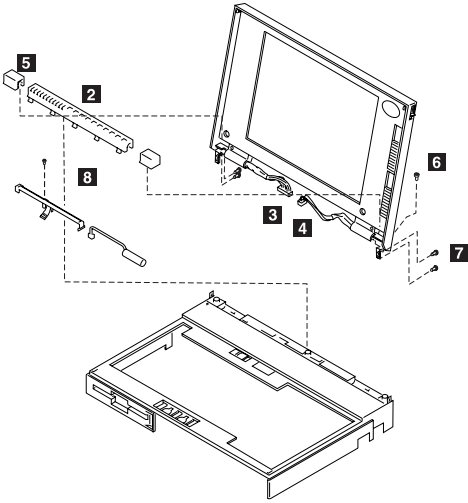

ThinkPad 720, 720C Exploded View

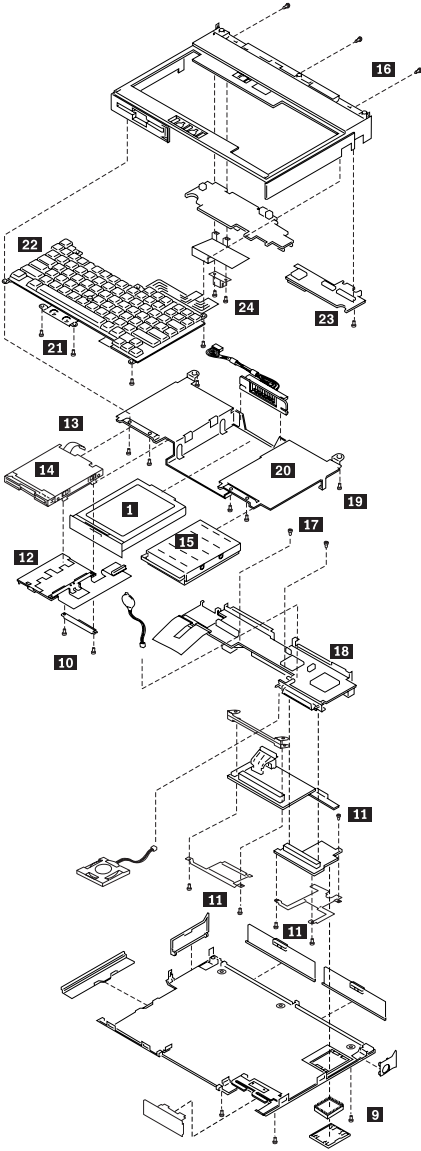

ThinkPad 720, 720C Exploded View (continued)

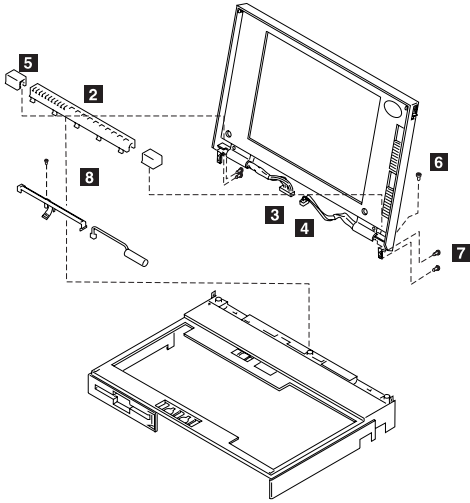

Locations

Front View

- 1** Release Lever
- 2** LCD
- 3** Contrast Control
- 4** Brightness Control
- 5** System Status Indicator
- 6** Power-On Light (green)
- 7** External Input Device Connector
- 8** System Power Switch
- 9** Keyboard
- 10** Reverse Video Switch
- 11** Hard Disk Drive
- 12** Integrated Pointing Stick
- 13** Battery Pack
- 14** Diskette-Eject Button
- 15** Diskette Drive
- 16** Speaker Volume
- 17** Suspend Switch

System Board (700)

- 1** External Input Device Connector
- 2** System-Expansion Connector (240-pin)
- 3** Parallel Connector
- 4** Serial Connector
- 5** Diskette Drive Connector
- 6** Password-override connector
- 7** Base Memory Card Interface
- 8** Video Card Interface
- 9** Backup Battery Connector
- 10** Processor Card Interface
- 11** Hard Disk Drive Connector
- 12** Speaker Connector
- 13** Voltage Converter Interface
- 14** System Status Indicator Connector
- 15** Keyboard Control Card Interface

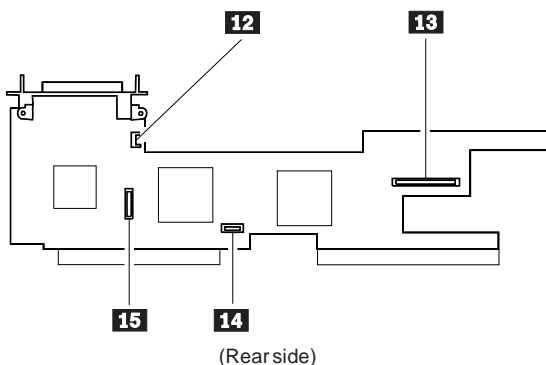
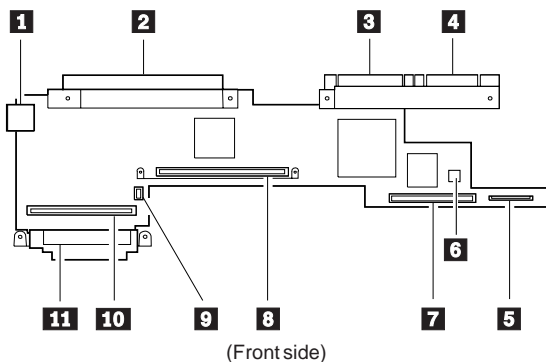

System Board (720, 720C)

- 1** External Input Device Connector
- 2** System-Expansion Connector (240-pin)
- 3** Parallel Connector
- 4** Serial Connector
- 5** Password-override Connector
- 6** PCMCIA Connector
- 7** Base Memory Card Interface
- 8** Video Card Interface
- 9** Backup Battery Connector
- 10** Hard Disk Drive Connector
- 11** Processor Card Interface
- 12** Keyboard Control Card Interface
- 13** Speaker Connector
- 14** Voltage Converter Interface
- 15** Diskette Drive Interface
- 16** System Status Indicator Connector

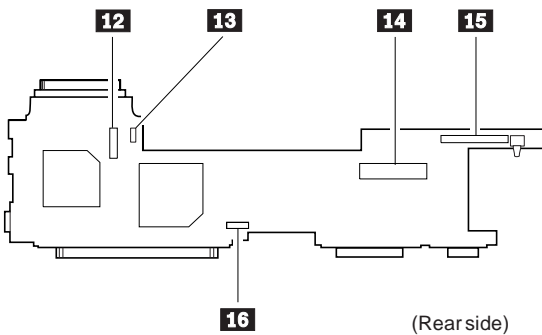
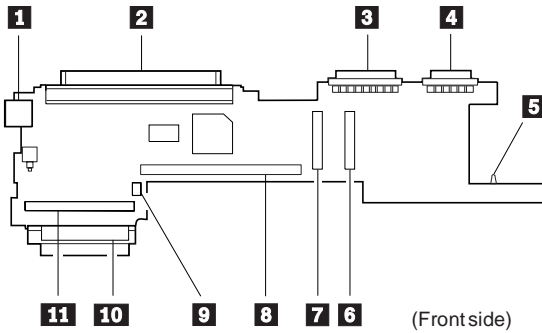

Video Card

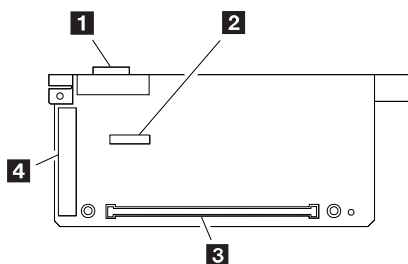

- 1** External Display Connector
- 2** LCD Connector
- 3** System Board Connector
- 4** Communication Adapter Connector

Keyboard Control Card

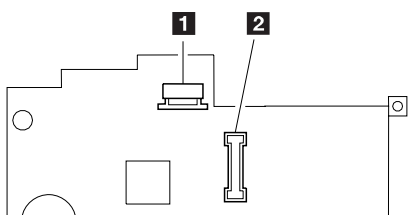

(Front side)

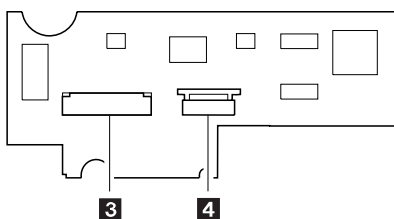

(Rear side)

- 1** Pointing Stick Connector
- 2** System Board Interface
- 3** Keyboard Connector
- 4** Keyboard Connector

Voltage Converter

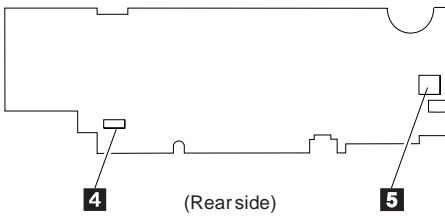
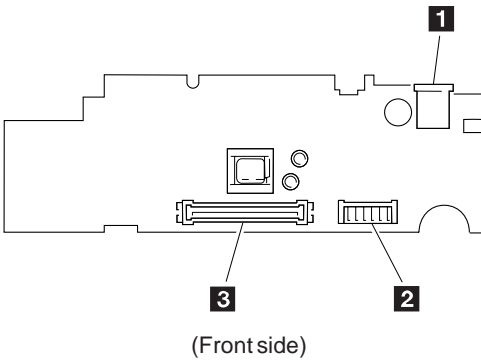

- 1** Power Jack
- 2** Battery Pack Interface
- 3** System Board Interface
- 4** Standby Battery Connector
- 5** Suspend/Resume Switch

Parts Listing (700)

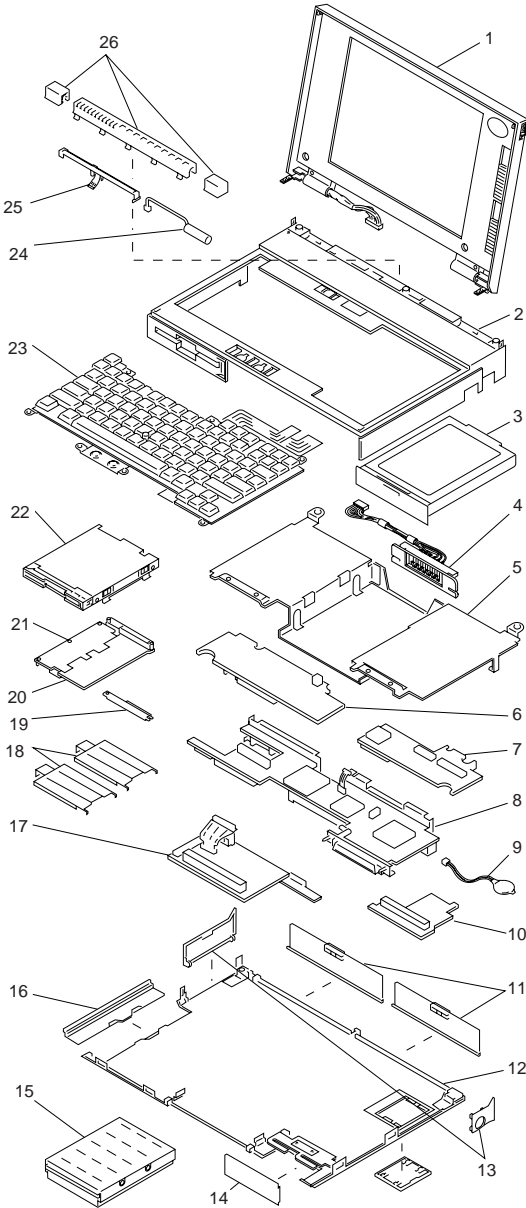

Index

1	LCD (700) 1	44G3806
	For Germany (Gray) (700) 1	48G9321
1	LCD Bezel Assembly (700) 1	53G7831
	For Germany (Gray) 1	53G7832
	Contrast and Brightness Slide (700)	53G7803
1	LCD (700C) 1	48G8723
	For Germany (Gray) (700C) 1	48G9909
1	LCD Hinge Kit	85G8199
1	LCD Case	44G3875
	Frame, Keyboard (700)	44G3797
	For Germany (Gray) (700)	48G9313
	For Japan (700)	44G3798
2	Frame, Keyboard (700C)	48G8945
	For Germany (Gray) (700C)	48G9905
	For Japan (700C)	48G8946
3	Battery Pack, Nickel Metal Hydride	44G3811
	For Benelux	49G2190
	For Germany (Gray)	49G2036
	For Swiss	44G3812
4	Battery Terminal Assembly	44G3779
5	Frame, Stiffener	44G3771
6	Voltage Converter w/lid susp. switch (700)	44G3784
	Voltage Converter w/lid susp. switch (700C)	48G8712
7	Keyboard Control Card, 84-key (U.S.)	44G3783
	Keyboard Control Card, 85-key	49G2096
	Keyboard Control Card, 89-key	49G2097
8	System Board (700)	44G3780
	System Board (700C)	49G1975
	50MHz Upgrade System Board (700)	54G1046
	240/340MB Upgrade System Board (700)	53G7822
	50MHz-240/340MB Upgrade System Board (700)	53G7824
	50MHz Upgrade System Board (700C)	54G1047
	240/340MB Upgrade System Board (700C)	53G7823
	50MHz-240/340MB Upgrade System Board (700C)	53G7825
	Power Switch Knob/Actuator	49G2140
	For Germany (Gray)	49G2156
	LED Flexible Plastic Cable	49G2142
9	Backup Battery, Lithium	44G3778
10	Processor Card	44G3781
10	50MHz Upgrade Processor Card (700,700C)	54G1045
11	I/O Connectors Cover Group	44G3769
	For Germany (Gray)	48G9315
12	Bottom Cover Assy, U.S.,Can,LAD (700)	44G3800
	For Benelux	54G0449
	For European Countries	44G3801
	For Germany (Gray)	48G9314
12	Bottom Cover Assy, U.S.,Can,LAD (700C)	48G8719
	For Benelux	49G2732
	For European Countries	48G8721
	For Germany (Gray)	49G1983
	For Japan	48G8722
13	Covers include spacers for LCD hinge	
	Model 700 Cover	53G7817
	For Germany (Gray)	48G9316

1 See "FRU Service Procedures" on page 124.

Index

	Model 700C Cover	48G8714
	For Germany (Gray)	48G9906
14	Door, Hard Disk Drive	44G3777
	For Germany (Gray)	48G9317
15	Hard Disk Drive, 80MB	95F4743
	Hard Disk Drive, 120MB	95F4744
	Hard Disk Drive, 240MB	66G3200
	Hard Disk Drive, 340MB	53G7862
16	Cover, IC DRAM Card	49G1108
	For Germany (Gray)	49G2154
17	Video Card (700)	44G3782
	Video Card (700C)	35G4823
18	Tray	44G3773
19	Guide, Modem	44G3774
	Modem Door (700)	53G7815
	Modem Door (700) (For Germany)	53G7816
	Modem Door (700C)	53G7817
	Modem Door (700C) (For Germany)	53G7818
	Telephone Cable	94X1540
20	Base Memory Card, 4MB	44G3785
21	Slot Holder, IC DRAM Card	44G3772
22	Diskette Drive Assembly	49G2198
	Cable, Diskette Drive	44G3776
23	Keyboard (see page 121)	
24	Standby Battery	44G3799
	For Benelux	49G1149
	For Swiss	49G2093
25	Indicator Assembly (700)	44G3787
	Standoff LED (700)	44G3788
25	Indicator Assembly (700C)	48G8729
	Standoff LED (700C)	48G8731
26	Panel Groups include LED cover, 2-2.5 x 8mm, left and right hinge bracket supports, left and right hinge cover end caps	
	Panel Cover Group (700)	44G3789
	For Germany (Gray)	48G9320
	Panel Cover Group (700C)	48G8715
	For Germany (Gray)	48G9908
	For Japan	49G1982
	Speaker	07G1229
	Holder, Speaker	44G3786
	AC Adapter (25W, 3-pin) (700)	44G3808
	AC Adapter (40W, 3-pin) (700C)	49G2196
	For Japan (40W, 2-pin)	49G2197
	Data/Fax Modem Adapter (U.S./Can.)	94X2554
	Data/Fax Modem Adapter (Japan only)	94X2506
	High-Speed Data/Fax Modem (U.S./Can.) ²	42G2592
	Serial Adapter	79F6840
	Internal Modem Attachment Screw	53G7847
	Screw Kit (see 720 parts for detail)	53G7819
	Foot, Right/Left (w/ springs)	49G2053
	For Germany (Gray)	49G2155
	Miscellaneous Parts Group (700)	44G3790
	Miscellaneous Parts Group (700C)	48G8944
	Parts Group includes keyboard support bracket, DC-in holder, battery terminal clip, stud, LCD cable clamp, mouse bracket shield, heat sink assembly, base cover hook bracket	

Parts Listing (720, 720C)

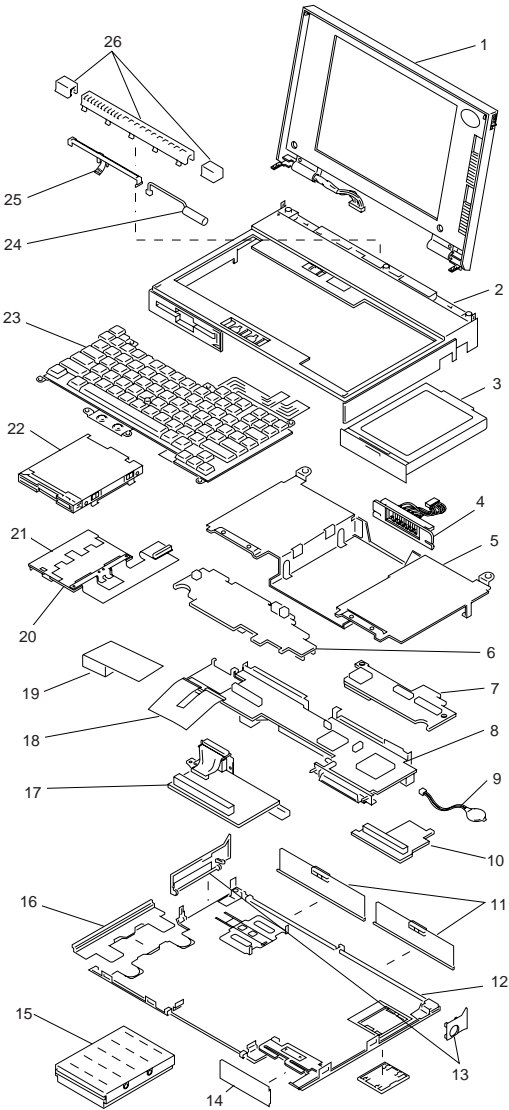

2 See "FRU Service Procedures" on page 124.

Index

1	LCD (720) ³	44G3806
	For Germany (Gray) ³	48G9321
	LCD (720C) ³	53G8137
	For Germany (Gray) ³	53G8138
1	LCD Bezel Assembly (720) ³	53G7831
	For Germany (Gray) ³	53G7832
1	LCD Hinge Kit	85G8199
1	LCD Case	44G3875
2	Frame, Keyboard (720)	53G9211
	For Germany (Gray)	53G9179
	Frame, Keyboard (720C)	53G9212
	For Germany (Gray)	53G9180
	For Japan	53G9209
3	Battery Pack, Nickel Metal Hydride	44G3811
	For Belgian and Dutch	49G2190
	For Germany (Gray)	49G2036
	For Swiss	44G3812
4	Battery Terminal Assembly	53G9202
5	Frame, Stiffener	44G3771
6	Voltage Converter w/ lid suspend switch	53G8114
7	Keyboard Control Card	
	84-key	44G3783
	85-key	49G2096
	89-key	49G2097
8	System Board (720)	53G9204
8	240/340MB Upgrade System Board (720)	53G7826
8	System Board (720C)	53G9205
8	240/340MB Upgrade System Board (720C)	53G7827
	Power Switch Knob/Actuator	49G2140
	For Germany (Gray)	49G2156
	LED Junction	53G9208
9	Backup Battery, Lithium	44G3778
10	Processor Card	54G1045
11	I/O Connectors Cover Group	44G3769
	For Germany (Gray)	48G9315
12	Bottom Cover Assembly (720)	53G9217
	For European Countries	53G9219
	For Belgian and Dutch	53G9221
	For Germany (Gray)	53G9181
	Bottom Cover Assembly (720C)	53G9218
	For European Countries	53G9220
	For Belgian and Dutch	53G9222
	For Germany (Gray)	53G9182
	For Japan	53G9215
13	Model Unique Cover (720)	53G9183
	For Germany (Gray)	53G9185
	Model Unique Cover (720C)	53G9184
	For Germany (Gray)	53G9186
14	Door, Hard Disk Drive	53G9172
	For Germany (Gray)	53G9173
15	Hard Disk Drive	
	120MB	95F4744
	160MB	54G0137
	240MB	66G3200
	340MB	53G7862

³ See "FRU Service Procedures" on page 124.

Index

16	Cover, IC DRAM Card	53G9187
	For Germany (Gray)	53G9188
17	Video Card (720)	53G9206
	Video Card (720C)	53G9207
18	Cable, Diskette Drive	53G9201
19	PCMCIA Card Slots	53G9190
20	Base Memory Card, 4MB	53G9203
21	Slot Holder, IC DRAM Card	53G9189
22	Diskette Drive Assembly	53G9200
23	Keyboard (see page 121)	
24	Standby Battery	44G3799
	For Belgian and Dutch	49G1149
	For Swiss	49G2093
25	Indicator Assembly (720)	53G9191
	Indicator Assembly (720C)	53G9192
	Standoff LED (720)	53G9193
	Standoff LED (720C)	53G9194
26	Panel Cover Groups include LED cover, two screws; 2.5 x 8mm, left and right hinge bracket supports, hinge cover end caps and hinge spacers	
26	Panel Cover Group (720)	53G9213
	For Germany (Gray)	53G9195
	Panel Cover Group (720C)	53G9214
	For Germany (Gray)	53G9196
	PCMCIA Door	53G9199
	For Germany (Gray)	53G9216
	Speaker	07G1229
	Holder, Speaker	44G3786
	Miscellaneous Parts Group (720)	53G9197
	Miscellaneous Parts Group (720C)	53G9198
	Parts Group includes Keyboard support bracket, DC-in holder, battery terminal clip, LCD cable clamp, mouse bracket shield, stud, Heat Sink Assembly, base cover hook bracket	
	Screw Kit	53G7819
	(Includes the following) 2.5 x 3 mm; 2.5 x 4 mm 2.5 x 5 mm; 2.5 x 12 mm 2.5 x 16 mm; 2.6 x 4 mm self-tapping	
	Foot Right/Left (w/ springs)	49G2053
	For Germany (Gray)	49G2155
	AC Adapter (40 W, 3-pin)	49G2196
	For Japan (40 W, 2-pin)	49G2197
	Cap, TrackPoint II	54G0439
	IC DRAM Card Eject Tape	53G9318

Options and Adapters

Important

When you replace the AC adapter or the Quick Charger with a new one, use the one available for the country you are in even though the system is from another country.

Options and Adapters

AC Adapter (50 W)	48G8942
AC Adapter for Japan, 3-pin	49G2206
Car Battery Adapter	49G1148
Keyboard/Mouse Cable	54G0444
IBM ThinkPad Port Replicator	53G9710
IBM IC DRAM Memory Card, 2MB	07G1414
IBM IC DRAM Memory Card, 4MB	07G1415
IBM IC DRAM Memory Card, 8MB	07G1416
Miniature Mouse	95F5723
NiMH Battery with Indicator	53G9166
Quick Charger	49G1110
Quick Charger for Japan, 2-pin	49G1111

Keyboards w/ Trackpoint II (700, 700C, 720, 720C)

Arabic	48G9249
Belgian	48G9238
Canadian French	48G9230
Danish	48G9243
Dutch	48G9247
Finnish	48G9241
French (AZERTY)	48G9235
German (Gray)	48G9236
Greek	48G9252
Hebrew	48G9251
Icelandic	48G9250
Italian	48G9237
Japanese	44G3796
Norwegian	48G9240
Portuguese	48G9246
Spanish	48G9239
Spanish Speaking	48G9231
Swedish/Finnish	48G9241
Swiss/French	48G9244
Swiss/German	48G9245
Turkish	48G9248
U.K.	44G3795
U.S. and European Countries	44G3794
Pointing Stick Caps (3)	54G0439

Numeric Keypad (700, 700C, 720, 720C)

Belgian	95F5741
Canadian French	95F5466
Danish	95F5467
Dutch	95F5467
French	95F6313
German	95F6314
Greek	95F5467
Hebrew	95F5741
Icelandic	95F5467
Italian	95F6316
Japan	79F6401
Norwegian	95F5467
Spanish	95F6315
Swedish/Finnish	95F5468
Swiss/French	95F5711
Swiss/German	95F5715
Turkish	95F5467
U.K. English	95F5741
U.S. English	95F5741

Tools

Tri-Connector Wrap Plug	72X8546
PC Test Card	35G4703
Audio Wrap Cable	66G5180
Screwdriver Kit	95F3598

Power Cords

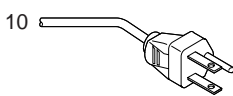
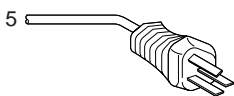
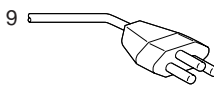
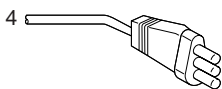
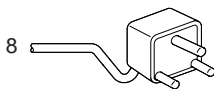
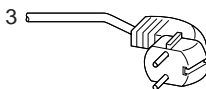
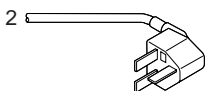
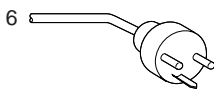
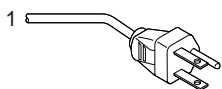

Warning: Use the power cord certified for your country.

1	Colombia, U.S., Venezuela Japan, 2-pin Japan, 3-pin	13F9959 6454377 65F0031
2	Hong Kong, Singapore, U.K.	14F0033
3	France, Germany, Spain	13F9979
4	Italy	14F0069
5	Australia, New Zealand	13F9940
6	Denmark	13F9997
7	Israel	14F0087
8	Bangladesh, Pakistan, Sri Lanka, South Africa	14F0015
9	Switzerland	14F0051
10	Thailand	1838574

FRU Service Procedures

Review these service procedures *before* replacing a FRU.

LCD FRU Replacement Notice: If missing or discolored dots appear on the LCD, carefully read the following note to determine whether or not you should replace the LCD.

The LCD for the Model 700C and 720C contains over 921 000 thin film transistors (TFTs). A small number of missing, discolored or lighted dots (on all the time) is characteristic of TFT LCD technology. Excessive pixel problems can cause viewing concerns. The LCD should be replaced if the number of missing, discolored, or lighted dots in any background is 21 or more.

Hinges on the color LCD are part of the FRU and are returned with the FRU.

700, 720 Mono LCD FRU Replacement:

Hinges are NOT part of the Model 700 or 720 mono LCD FRU (do not return them with the FRU). When replacing the Model 700 or 720 mono LCD, remove the right and left hinge bracket supports and install them on the new LCD. Return only the main FRU. The left and right hinge bracket supports are included in the Mono Panel Cover Group Kit.

High-Speed Modem Noise Problems: A small number of high speed modems might produce a noise when the system is powered-on. To solve this problem, copy PS2.EXE from the Reference Diskette to the root directory using the UINSTALL program. Then, add the following lines to the AUTOEXEC.BAT file.

```
PS2 SET MODEM OFF  
PS2 SET MODEM ON
```

If this does not solve the problem, replace the modem.

ThinkPad 701C/701CS (2630)

Checkout Guide	127
General Checkout	128
Memory Checkout	128
Keyboard/Auxiliary Input Device Checkout	131
TrackPoint III Checkout	132
Diskette Drive Checkout	133
Hard Disk Drive Checkout	133
MultiPort II Checkout	134
Power Systems Checkout	135
Infrared Transceiver Checkout	137
PCMCIA Checkout	139
Symptom-to-FRU Index	141
Numeric Error Codes	142
FRU Codes	144
Beep Symptoms	145
No-Beep Symptoms	146
LCD-Related (Video) Symptoms	146
Keyboard and TrackPoint III Symptoms	148
MultiPort II Related Symptoms	148
Indicator Related Symptoms	149
Power Related Symptoms	149
Function Related Symptoms	150
Infrared Related Symptoms	151
Audio Related Symptoms	151
Peripheral Device Related Symptoms	151
Other Symptoms	152
Intermittent Problems	152
Undetermined Problems	152
Related Service Procedures	154
Understanding Fn Key Combinations	154
Reading Status Indicators	155
Understanding the Power-On Self-Test	155
Removing the Power-On Password	156
Running the Diagnostics	156
Printing and Displaying Error Logs	157
Checking Installed Devices	157
Running the Low-Level Format	158
Reading the PC Test Card LED	158
Removing PCMCIA Cards	159
Product Overview	159
FRU Removals and Replacements	161
Disassembling the ThinkPad 701C/701CS	163
Disassembling the LCD Assembly	172
Replacing the Top System Board	178
Removing and Replacing the SO-DIMM Card	178
Locations	181
System (Front View)	181
System (Left Side View)	182
System (Right Side View)	182
System (Rear View)	183
Top System Board (Top View)	184

Top System Board (Bottom View)	185
Bottom System Board (Top View)	186
Bottom System Board (Bottom View)	187
Inverter Card (Front View)	188
Inverter Card (Rear View)	188
MultiPort II (Front View)	189
MultiPort II (Rear View)	189
Parts Listing	190
Common/Option Parts List	192

Checkout Guide

Service for U. S. and Canada

In the U. S. and Canada, the ThinkPad 701C/701CS is serviced only through EasyServe.

Use the following procedure as a guide for computer problems:

1. Ask the customer for as much detail as possible about the failing symptoms.
2. Verify the symptoms by attempting to recreate the failure either by running the diagnostics test or by repeating the same operation. (To run the diagnostics, refer to "Running the Diagnostics" on page 156.)
3. Use the following table with the verified symptom to determine which page to go to. Search the symptoms column and find the description that best matches your symptom; then, go to the page shown in the "Go to" column.

Note: Before replacing any FRU, see "FRU Removals and Replacements" on page 161.

Symptom	Go to
Power failure. (The power indicator does not go on or stay on.)	"Power Systems Checkout" on page 135.
POST does not complete. No beeps or error codes are indicated.	"No-Beep Symptoms" on page 146.
POST beeps, but no error codes are displayed.	"Beep Symptoms" on page 145.
POST detected an error and displayed numeric error codes.	"Numeric Error Codes" on page 142.
The diagnostics test detected an error and displayed a FRU code.	"FRU Codes" on page 144.
The configuration is not the same as for the installed devices.	"Checking Installed Devices" on page 157.
Other symptoms (such as LCD display problems).	"Symptom-to-FRU Index" on page 141, and then use the symptoms tables.
Symptoms cannot be recreated. (Intermittent problems.)	Use the customer-reported symptoms and also see "Intermittent Problems" on page 152.

General Checkout

The diagnostic tests are intended to test *only* IBM products. Non-IBM products, prototype cards, or modified options can give false errors and invalid system responses.

Warning:

- Only trained personnel should service the computer.
- Drives in the computer that you are servicing might have been rearranged or the drive startup sequence might have been altered. Be extremely careful during write operations such as copying, saving, or formatting. Data or programs can be destroyed if you select an incorrect drive.

Perform the following procedures to complete a general checkout:

1. Power-off the computer and all external devices.
2. Check all cables and power cords for correct connection.
3. Power-on all external devices.
4. Power-on the computer.
5. Press the **F1** key any time while the POST memory count is proceeding. The computer emits one short beep at the end of POST and the Easy-Setup screen appears. If this does not occur, go to "Symptom-to-FRU Index" on page 141.
6. Run the advanced diagnostics tests. For information on how to run the diagnostics tests, see "Running the Diagnostics" on page 156. For information on how to disable the password, see "Removing the Power-On Password" on page 156.
7. Find your symptom in the table in "Checkout Guide" on page 127, and then go to the appropriate page. Otherwise, see "Symptom-to-FRU Index" on page 141, and then go to "Undetermined Problems" on page 152.

Memory Checkout

Depending on the amount of additional memory installed by the customer, the memory size that is available for customer use appears differently. This is *not* a hardware problem. Consult the following table for the available memory on a system with a 4MB base memory when the customer installs different sizes of small outline dual inline memory module (SO-DIMM).

SO-DIMM Installed	Total Memory	Available Memory
None	4MB	3712KB
4MB	8MB	7808KB
8MB	12MB	11904KB
16MB	20MB	20096KB

The following table shows the available memory on a system with an 8MB base memory with different sizes of SO-DIMM.

SO-DIMM Installed	Total Memory	Available Memory
None	8MB	7 808KB
4MB	12MB	11 904KB
8MB	16MB	16 000KB
16MB	24MB	24 192KB

Memory errors might stop system operations or cause error codes to be displayed.

Use the following procedure to isolate memory problems:

Note: Make sure that the SO-DIMM is fully installed in the connector. A loose connection can cause an error. For more information about installing SO-DIMMs, see “FRU Removals and Replacements” on page 161.

1. Power-on the computer. Press the **F1** key any time while the POST memory count is proceeding. At the end of the memory test, the Easy-Setup screen appears.
2. Select **Test** and press **Enter**.
3. Press **Ctrl+A** to enter advanced diagnostics.
4. Select **Memory** and press **Enter** to run the memory test on base memory.
 - If an error appears below 3712KB on a system with a 4MB base memory (7808KB with an 8MB base memory), replace the bottom system board.
 - If an error appears above 3712KB on a system with 4MB base memory (7808KB with an 8MB base memory), replace the SO-DIMM.
5. If after replacing the SO-DIMM, an error above 3712KB on a system with a 4MB base memory or 7808KB with an 8MB base memory still appears, replace the bottom system board.
6. To exit from the test screen, press **Esc**.

If memory problems occur intermittently, use the loop option to repeat the test. For more information on running the loop test, see “Running the Diagnostics” on page 156. When the test detects an error, an error log is printed on the printer connected to the parallel port. See “Printing and Displaying Error Logs” on page 157 for more information.

Do not replace FRUs because of a single, nonreproducible failure. Single failures can occur for a variety of reasons that have nothing to do with a hardware defect, such as electrostatic discharge or software errors. Consider replacing a FRU only when a recurring problem exists. If you suspect that problems besides a failing FRU exist,

clear the error log and run the test again. Do not replace any FRUs if errors do not reoccur.

Updating Flash Memory: BIOS and Easy-Setup, which includes configuration programs and diagnostic tests, are stored in Flash memory. To update them, Flash memory must be updated.

When Updating Flash Memory

Do not power-off the computer, disconnect the Vac power, or remove the battery pack during the Flash update. The system board will have to be replaced if the update is interrupted.

Updating Flash memory also resets all of the customer's configuration settings to the default values.

To update the Flash memory, perform the following steps:

1. Within the Configuration Utility, check the "Startup Sequence" setting and make sure that it is set to **Smart** or **Conventional**. If it is set to **Hard Disk**, change the setting to **Smart** or **Conventional** to set the system to boot from the update diskette in the following procedure.

If you change the user's setting, make a note of the setting before changing it.

2. Power-off the computer.
3. Connect the computer to Vac power and install a charged battery pack.
4. Insert the Flash update diskette in drive A.
5. Power-on the computer.
6. Follow the instructions as they appear to update Flash memory.
7. Power-off the computer, and then power it on again. Error codes 162 and 163 will be displayed.

Press **Enter** to enter the Configuration Utility. Reset the date and time.

8. Press **Esc** to leave the Configuration Utility, and then press **Enter** to save the changes.
9. If the Flash update fails, replace the bottom system board. Save the system board that failed, marking it "to be reflashed."

Keyboard/Auxiliary Input Device Checkout

Remove the external keyboard if the internal keyboard is to be tested.

If the internal keyboard does not work or an unexpected character appears, make sure that the three flexible cables extending from the keyboard are correctly seated in the connectors on the top system board.

If the keyboard cable connection is correct, run the **Keyboard Test** by performing the following steps:

1. Power-off the computer, and then power it on again.
2. Press the **F1** key any time while the POST memory count is proceeding. At the end of the memory test, the Easy-Setup screen appears.
3. Press the left or right arrow key to select **Test** and press **Enter** or position the pointer over the **Test** icon and click the left click button once.
4. Press **Ctrl+A** to enter advanced diagnostics.
5. Press **Ctrl+K** to start the keyboard diagnostics test.
6. Press each key. A shaded box appears in the corresponding key position on the keyboard layout on the screen. Press the key again to remove the box.

Note: The shaded box appears in **Fn** only during the first keyboard test of a diagnostics session.

7. To exit from the test screen, press **Esc**.

If the tests detect a keyboard problem, perform the following tasks one at a time to correct the problem:

Note: Do not replace a nondefective FRU.

- Reseat the three cables.
- Replace the keyboard.
- Replace the top system board.

The following auxiliary input devices are supported for this computer through the MultiPort II:

- Numeric keypad
- Mouse (PS/2* compatible)
- External keyboard (standard PS/2 or with keyboard/mouse cable)

If any of the above devices do not work, reseat the cable connector and repeat the failing operation. If the problem does not reoccur, recheck the connector. If the problem reoccurs, repeat the operation with a device that is known to be good. If the problem still reoccurs, go to "MultiPort II Checkout" on page 134.

TrackPoint III Checkout

If the TrackPoint III does not work, check the configuration in the Configuration Utility by pressing **PgDn** to reach the **I/O Management** screen. If the setting for TrackPoint III is Off, press the left or right arrow to change it to On. If this does not correct the problem, continue with the following procedure:

Note: The TrackPoint III performs automatic compensations to adjust the pointer sensor. During this process, the pointer moves about the screen for a short time. This self-acting pointer movement can occur when a slight, steady pressure is applied to the TrackPoint III pointer when the computer is powered on, when the system is running, or when readjustment is required because the temperature has changed significantly within a short period of time or the temperature is higher than its operating temperature. This symptom does not indicate a hardware problem. No service actions are necessary if the pointer movement stops in a short period of time. However, the TrackPoint III will not stabilize if you apply pressure to it. If pointer movement occurs, you can go into Suspend mode, and then resume normal operation. Resuming or turning the computer on both cause the TrackPoint III to be calibrated, which may correct the problem. If you see continual movement of the pointer, the TrackPoint III is probably defective. In rare cases, the top system board can also cause this problem.

If a click-button problem or TrackPoint III problem occurs, perform the following steps:

1. Power-off the computer, and then power it on again.
2. Press the **F1** key any time while the POST memory count is proceeding. At the end of the memory test, the Easy-Setup screen appears.
3. Select an item with the TrackPoint III.
4. Press either the left or right click button.
5. Verify that both buttons work correctly.

If either the TrackPoint III or the click button does not work, perform the following tasks one at a time to correct the problem:

Note: Do not replace a nondefective FRU.

- Reseat the three keyboard cables.
- Replace the keyboard.
- Replace the top system board.

Diskette Drive Checkout

Use the following procedure to isolate the diskette problem to a controller, drive, or diskette. For this test, you need a scratch, write-enabled, double-sided, high-density diskette (2.0MB that formats to 1.44MB) that is known to be good.

1. Power-off the computer.
2. Attach the external diskette drive if it is not already attached.
3. Power-on the computer.
4. Press the **F1** key any time while the POST memory count is proceeding. When the memory test is completed, the Easy-Setup screen appears.
5. Press the left or right arrow key to select **Test** and press **Enter** or position the pointer over the **Test** icon and click the left click button once.
6. Press **Ctrl+A** to enter the advanced diagnostics.
7. Select the **FDD-1** icon and press **Enter**. This runs the controller test and the drive read/write test.
8. If the controller test detects an error, FRU code 10 appears. First, replace the diskette drive and cable and run the test again. If FRU code 10 appears from this second test, replace the top system board.
9. If the controller test runs without errors, select **Tool** from the advanced diagnostics screen. (See "Running the Diagnostics" on page 156 for instructions.) Select the **FDD-1** icon and insert a scratch diskette to continue with the drive test.
10. Select the **FDD-1** icon from the advanced diagnostics screen and press **Enter**.
11. If the drive test detects an error, FRU code 50 appears. Replace the drive or the drive cable.
12. To exit from the test screen, press **Esc**.

Hard Disk Drive Checkout

1. Power-off the computer.
2. Insert the hard disk drive to be tested.
3. Power-on the computer. Press the **F1** key any time while the POST memory count is proceeding. When the memory test is completed, the Easy-Setup screen appears.
4. Press the left or right arrow key to select **Test** and press **Enter** or position the pointer over the **Test** icon and click the left click button once.
5. Press **Ctrl+A** to enter advanced diagnostics. and press **Enter**.
6. If the test detects an error, FRU code 60 appears under the **HDD-1** icon. Replace the hard disk drive.
7. To exit from the test screen, press **Esc**.

MultiPort II Checkout

Use the following procedure to isolate a MultiPort II problem. The MultiPort II attaches to the system expansion connector at the rear of the computer.

1. Power-off the computer.
2. Remove all of the devices from the MultiPort II.
3. Unplug the AC adapter from the computer, if attached, and plug the AC adapter into the MultiPort II if it is not already attached.
4. Attach wrap plugs to the serial port and the parallel port on the MultiPort II.
5. Power-on the computer.
6. Press the **F1** key any time while the POST memory count is proceeding. When the memory test is completed, the Easy-Setup screen appears.
7. Press the left or right arrow key to select **Test** and press **Enter** or position the pointer over the **Test** icon and click the left click button once.
8. Press **Ctrl+A** to enter advanced diagnostics.
9. Select **Tool** to install the wrap plugs on the ports. (See "Running the Diagnostics" on page 156 for instructions.)
10. Run the diagnostics tests on the parallel and serial ports on the computer and the MultiPort II. To test the external display device, select the **Display** icon. Test results will be displayed under the icon for each selected device.
11. If the diagnostics tests do not find errors, suspect a problem with the previously attached devices.

If the tests find errors, perform the following steps to recheck the computer:

- Power-off the computer.
- Remove the MultiPort II from the computer.
- Power-on the computer and rerun the tests on the available parallel and serial ports.

If the errors do not reoccur, replace the MultiPort II.

If the errors persist, suspect that the errors are related to internal FRUs and replace the appropriate FRU (for information on FRU codes, see "FRU Codes" on page 144).

12. If power problems appear only when using the MultiPort II, replace the MultiPort II.
13. To exit from the test screen, press **Esc**.

Power Systems Checkout

To verify the symptom of the problem, power-on the computer using each of the power sources available as follows:

1. Remove the battery.
2. Connect the AC adapter and check that power is supplied by pressing the power switch.
3. Disconnect the AC adapter and install the charged battery; then, check that power is supplied from the battery by pressing the power switch.

Note: The battery is charged only while the computer is powered-on (the computer can be in the suspend mode). The battery cannot be charged if the computer is powered-off.

If you suspect a power problem, see the appropriate power-supply check listed below:

- “Checking the AC Adapter.”
- “Checking the Battery Pack” on page 136.
- “Checking the Standby Battery” on page 137.

Checking the AC Adapter: Check the AC adapter if the computer fails only when the AC adapter is used, or if the battery does not charge when the AC adapter is attached and the computer is on or in suspend mode.

- If the power problem occurs only when the MultiPort II is used, replace the MultiPort II.
- If the power-on indicator does not turn on, check the AC adapter for correct continuity and installation. If the connection is suspect, replace the AC adapter.
- If the operational charge does not work, go to “Power Related Symptoms” on page 149.

Note: Several types of AC adapters can be supplied with the ThinkPad 701C/701CS. The procedure for checking them is the same.

1. Unplug the AC adapter cable from the computer and measure the output voltage at the plug of the AC adapter cable. See the following figure.

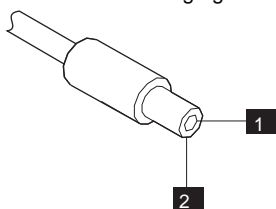

Pin	Voltage (V dc)
1	+15.5 to +17.0
2	Ground

- If the voltage is not correct, replace the AC adapter.
Note: In rare cases, the problem may be in the AC adapter even when the voltage is correct. If an AC adapter is available, try replacing the computer's AC adapter.
- If the voltage is correct, replace the top system board.
If this does not correct the problem, go to "Undetermined Problems" on page 152.

Note: An audible noise from the AC adapter does not always indicate a defective adapter.

Checking the Battery Pack: Perform the following steps to check the battery:

Safety Notice 7: Translation on page 12

Though main batteries have low voltage, a shorted or grounded battery can produce enough current to burn combustible materials or personnel.

- Remove the battery.
Note: To remove the battery, end external communications if you are not using an AC adapter. Power-off the computer, and then close the lid. Unlock the battery compartment door located on the bottom of the computer. Slide the battery out of the compartment.
- Measure the voltage between battery terminals 1 (+) and 4 (-). See the following figure.

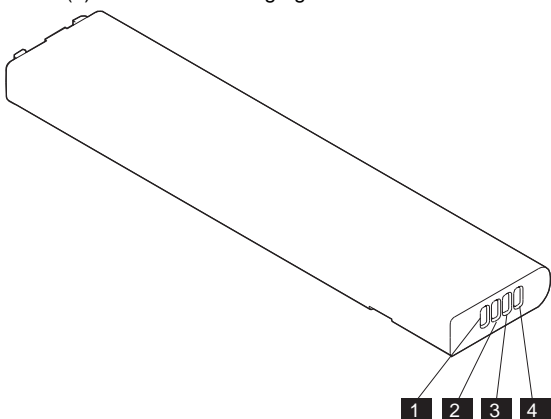

Terminal	Voltage (V dc) / Signal
1	11.0 (nominal) (Range +10.0 to +16.0)
2	VCC
3	I/O
4	Ground

Note: The signal lines not used in these steps, terminals 2 and 3, are used for communication between the system and the battery.

3. If the voltage is less than +10.0 V dc, the battery has been discharged or is defective. Recharge the battery.

If the voltage is still less than +10.0 V dc after the recharging, replace the battery.

Checking the Standby Battery: Before performing the following steps, make sure that the standby battery is fully charged by leaving the computer plugged into ac power while on or in suspend mode for 24 hours. The computer can be used normally while the standby battery is charging. If any problem is not corrected after charging the standby battery, perform the following steps.

1. Power-off the computer and unplug the AC adapter from the computer.
2. Remove the battery.
3. Remove the top system board.
4. Replace the standby battery from the bottom of the top system board.
5. Reinstall the top system board.
6. Plug the computer into ac power, power-on the computer, and let the standby battery charge for 24 hours.
7. To verify standby battery operation, remove and reinstall the battery while the computer is in the suspend mode.

Note: For this test to be valid, the battery should be reinstalled within 1 minute.

The resume operation should start.

8. If the resume operation does not work, replace the top system board.

Infrared Transceiver Checkout

The infrared transceiver is located on the inverter card in the ThinkPad 701C/701CS. When you run diagnostics on the infrared transceiver, the test is actually checking the top system board, not the infrared transceiver itself. Therefore, complete the following steps before running diagnostics or replacing any FRUs.

If the customer cannot establish a connection between the ThinkPad 701C/701CS and a remote system, perform the following steps:

1. Ensure that the device the customer attempted to connect with is an Infrared Data Association (IRDA) compliant device.
2. Check to make sure that both systems are using the same revision level of the same software.
3. Check setup options on both systems to ensure that the baud rate and other setup parameters are the same.
4. Check the Configuration Utility to ensure that the infrared transceiver is assigned to the same serial port that is designated in the application software and that the IRQ assignment is not shared with any other device such as the internal modem or external serial port on the MultiPort II.
5. Verify that the two systems are in close proximity (less than 1 meter [3.2 feet] apart for IRDA-compliant devices) and that the infrared transceiver window on the ThinkPad 701C/701CS is aligned with (directly opposite) the remote device's window.
6. Ensure that the windows on both systems are clean and unobstructed.

If the two systems still will not connect after you have followed the preceding steps and the remote system is another computer with a terminal program (for example, Windows** Terminal** or Procomm**) installed, perform the following tests:

1. Set up the terminal application on each system to communicate with the infrared transceiver serial port at a speed of 115KB per second.
2. Type characters on the ThinkPad 701C/701CS keyboard and check to see whether or not these characters appear on the remote system. (Note that the characters you type will not appear on the ThinkPad 701C/701CS system.)
3. Type characters on the remote keyboard and check to see whether or not these characters appear on the ThinkPad 701C/701CS system.
4. If characters do not appear in either step 2 or 3 and you are certain that infrared is working correctly on the remote system, replace the inverter card.
5. If characters do appear, consult the software vendor to ensure that the customer is using a compatible software package and that the setup parameters are correct.

If data transfers between the ThinkPad 701C/701CS and the remote system are slow or unstable:

1. Verify that the two systems are in close proximity (less than 1 meter [3.2 feet] apart for IRDA-compliant devices) and that the infrared window on the ThinkPad 701C/701CS is aligned with the remote device's window.
2. Ensure that the windows on both systems are clean and unobstructed.
3. If you are using TranXit, check the IRDELAY parameter in the TRANXIT.INI file in the TRANXIT directory. The parameter should be set to 10.

To run the diagnostics test on the infrared transceiver, perform the following steps:

1. Power-off the computer, and then power it on again.
2. Press the **F1** key any time while the POST memory count is proceeding. When the memory test is completed, the Easy-Setup screen appears.
3. Press the left or right arrow key to select **Test** and press **Enter** or position the pointer over the **Test** icon and click the left click button once.
4. Press **Ctrl+A** to enter advanced diagnostics.
5. Select **Infrared** and press **Enter** to run the test on the infrared transceiver. Test results will be displayed under the **Infrared** icon.
6. If no errors are detected, the "OK" message appears.
7. If an error is detected, the FRU code and error description message appear. Go to "FRU Codes" on page 144 and replace the FRU.
8. To exit from the test screen, press **Esc**.

PCMCIA Checkout

For a more thorough test, use one PCMCIA card in each slot. Perform the following steps to test the PCMCIA** slots:

1. Power-off the computer, and then power it on again.
2. Press the **F1** key any time while the POST memory count is proceeding. When the memory test is completed, the Easy-Setup screen appears.
3. Press the left or right arrow key to select **Test** and press **Enter** or position the pointer over the **Test** icon and click the left click button once.
4. Press **Ctrl+A** to enter advanced diagnostics.
5. If you are using PC test cards, select **Tool** to install them. Insert the cards when prompted. (For instructions on installing test cards, see "Running the Diagnostics" on page 156. For instructions on inserting the cards, see "Removing PCMCIA Cards" on page 159.)

6. Select the **PCMCIA** icon and press **Enter** to run the test on the PCMCIA slots. The green LED on the PCMCIA card should turn on when the test runs. (If the green LED does not turn on, see “Reading the PC Test Card LED” on page 158.) Test results will be displayed under the **PCMCIA** icon.
7. If no errors are detected, the “OK” message appears.
8. If an error is detected, the FRU code and error description message appear. Go to “FRU Codes” on page 144 and replace the FRU.
9. To exit from the test screen, press **Esc**.

Symptom-to-FRU Index

The Symptom-to-FRU Index contains tables that list causes of symptoms. The most likely cause is listed first. Use this index to help you decide which FRUs to have available when servicing a computer.

Safety Notice 8: Translation on page 13

Before removing any FRU, power-off the computer, unplug all power cords from electrical outlets, remove the battery pack, then disconnect any interconnecting cables.

Perform the FRU replacement or actions in the sequence shown in the "FRU / Action" columns. If the replacement FRU did not solve the problem, put the original FRU back in the computer.

Notes:

1. Before replacing the top and bottom system boards, try reseating the boards. If reseating the boards does not correct the problem, replace the boards.
2. If possible, install the latest level of BIOS available before replacing any FRU.

Before completely reassembling a computer that has been repaired, try to reboot the computer to check the repairs that have been completed. However, when you reboot without the keyboard attached, the computer will display error codes 8603, 8613, and 86XX.

Use displayed numeric error codes to determine the system problem. If numeric error codes are not available, use the other symptom tables that describe specific symptoms. If the symptom is not listed, go to "Undetermined Problems" on page 152.

Note:

For IBM devices not supported by diagnostics codes of ThinkPad 701C/701CS, see the manual for those devices.

Numeric Error Codes

Numeric error codes show the errors detected in POST or system operation. Use the error codes displayed on the screen to diagnose failures. If more than one error code is displayed, begin the diagnosis with the first error code. The cause of the first error code can result in false error codes being displayed.

In the following error codes, **X** can be any number.

Symptom/Error	FRU/Action
02X, 101, 107	<ol style="list-style-type: none">Battery.AC AdapterMemory Option.Top System Board.
10X	<ol style="list-style-type: none">Bottom System Board.
119	<ol style="list-style-type: none">Top System Board.
161, 163	<ol style="list-style-type: none">Set Configuration. (Press Fn+F1 to enter the Configuration Utility and set the time and date.)Top System Board.Bottom System Board.
162 (Check the Installed Devices list for a missing device.)	<ol style="list-style-type: none">Set Configuration. (Press Fn+F1 to enter the Configuration Utility and set your configuration.)Any Missing Device.Top System Board.Bottom System Board.
164 (Memory size error)	<ol style="list-style-type: none">If a SO-DIMM card has been removed, press Fn+F1 to enter the Configuration Utility, and verify the memory size.Replace the installed SO-DIMM.Bottom System Board.
184	<ol style="list-style-type: none">Press Fn+F1 to enter the Configuration Utility, and then reset the Power-on Password.
195 (The hibernate partition does not match memory size.)	<ol style="list-style-type: none">Check if the disk drive is from another computer or if the memory size has changed.Go to “Hard Disk Drive Checkout” on page 133.Hard Disk Drive

Symptom/Error	FRU/Action
196 (Read error occurred in the hibernate area of the Hard Disk Drive.)	<ol style="list-style-type: none"> 1. Disable, and then enable Hibernate mode. 2. Go to "Hard Disk Drive Checkout" on page 133. 3. Hard Disk Drive
197 (The computer memory size is not equal to the hibernate area size on the Hard Disk Drive.)	<ol style="list-style-type: none"> 1. Disable, and then enable Hibernate mode.
1XX (Not listed above.)	<ol style="list-style-type: none"> 1. Top System Board. 2. Bottom System Board.
2XX	<ol style="list-style-type: none"> 1. Go to "Memory Checkout" on page 128. 2. SO-DIMM 3. Bottom System Board
3XX (Before replacing FRUs, power-off, and then power-on the computer.)	<ol style="list-style-type: none"> 1. Remove attached external devices. 2. Reseat cables. 3. Keyboard 4. Top System Board
6XX	<ol style="list-style-type: none"> 1. Go to "Diskette Drive Checkout" on page 133. 2. Diskette 3. Diskette Drive Cable 4. Diskette Drive 5. Top System Board
09XX, 10XX	<ol style="list-style-type: none"> 1. Top System Board.
11XX	<ol style="list-style-type: none"> 1. Modem 2. Top System Board 3. Bottom System Board
17XX	<ol style="list-style-type: none"> 1. Go to "Hard Disk Drive Checkout" on page 133. 2. Hard Disk Drive 3. Bottom System Board
24XX (For external displays, see the "External Display Self-Test" in the Common Devices Checkout section before replacing any FRUs.)	<ol style="list-style-type: none"> 1. External Display. 2. External Display Power Cord. 3. Backlight Lamp Assembly. 4. LCD Assembly. 5. Bottom System Board. 6. Inverter Card.
8000	<ol style="list-style-type: none"> 1. Set Configuration. 2. PCMCIA Card. 3. Bottom System Board.

Symptom/Error	FRU/Action
860X (Pointing device error when TrackPoint III is disabled.)	<ol style="list-style-type: none"> External Mouse. External Keyboard. Top System Board. Bottom System Board.
861X (Pointing device error when TrackPoint III is enabled.)	<ol style="list-style-type: none"> Reseat the TrackPoint III cable (the narrowest keyboard cable) at the Top System Board. External Mouse. Keyboard. Top System Board. Bottom System Board.
86XX (Not listed above)	<ol style="list-style-type: none"> Pointing Device. TrackPoint III. Keyboard. Numeric Keypad. Top System Board. Bottom System Board.
12902	<ol style="list-style-type: none"> Bottom System Board.
I9990305	<ol style="list-style-type: none"> Go to “Hard Disk Drive Checkout” on page 133. Hard Disk Drive Bottom System Board
Other codes not listed above	<ol style="list-style-type: none"> Go to “Undetermined Problems” on page 152.

FRU Codes

If an error is detected by the diagnostics tests, a *four-digit* FRU code is displayed, along with an error code. The FRU code indicates two suspected FRUs. Replace the FRU that is indicated by the *two leftmost digits* first, and then replace the FRU indicated by the *two rightmost digits*. No FRU is assigned to code 00. If only one FRU is suspected, the other FRU code is filled with zeros. See the referenced page before replacing the FRU.

FRU Code	FRU/Action
10	<ol style="list-style-type: none"> Diskette Drive Bottom System Board Top System Board
12	Top System Board
14	Bottom System Board
20	Memory (See “Memory Checkout” on page 128.)
32	External Keyboard
33	External Mouse

FRU Code	FRU/Action
40	LCD Assembly (See "Disassembling the LCD Assembly" on page 172.)
45	External CRT
50	<ol style="list-style-type: none"> 1. Reseat the Diskette Drive (FDD-1). 2. Diskette Drive (FDD-1)
51	<ol style="list-style-type: none"> 1. Reseat the Diskette Drive (FDD-2). 2. Diskette Drive (FDD-2)
55	<ol style="list-style-type: none"> 1. Insert a correctly formatted 2.0MB diskette into the Diskette Drive.
60	<ol style="list-style-type: none"> 1. Reseat the Hard Disk Drive (HDD-1). 2. Hard Disk Drive (HDD-1)
61	<ol style="list-style-type: none"> 1. Reseat the Hard Disk Drive (HDD-2) on the docking station. 2. Hard Disk Drive (HDD-2)
70	External PCMCIA
81	Internal Modem Card
91	<p>If MultiPort II is installed:</p> <ol style="list-style-type: none"> 1. Reseat MultiPort II. 2. MultiPort II. <p>If Dock II is installed:</p> <ol style="list-style-type: none"> 1. Reseat Dock II. 2. Dock II

Note: The device ID and error codes are used to indicate in detail the portion of the FRU that caused the error. If replacing a FRU does not correct a problem, see the device ID or error code from the previous failure. If they have changed, the new FRU might be defective or incorrectly installed.

If the problem remains after replacement of the FRUs, go to "Undetermined Problems" on page 152.

Beep Symptoms

Symptom/Error	FRU/Action
Continuous beeps.	<ol style="list-style-type: none"> 1. Top System Board
One beep and a blank, unreadable, or flashing LCD.	<ol style="list-style-type: none"> 1. Reseat all LCD connectors. 2. LCD Assembly 3. Bottom System Board
One beep, and the message "Unable to access boot source."	<ol style="list-style-type: none"> 1. Boot device 2. System Board
One long, two short beeps, and a blank or unreadable LCD.	<ol style="list-style-type: none"> 1. Bottom System Board. 2. LCD Assembly

Symptom/Error	FRU/Action
One long beep followed by four short beeps each time the power switch is operated. (System cannot power-on due to low battery voltage.)	1. Connect the AC adapter or install a fully charged battery.
One beep every second. (System is entering Suspend mode due to low battery voltage.)	1. Connect the AC adapter or install a fully charged battery (allows system to suspend operation before changing the battery).
Two short beeps with error codes.	1. POST error. See “Numeric Error Codes” on page 142.
Two short beeps with blank screen.	1. Top System Board. 2. Bottom System Board.

No-Beep Symptoms

Symptom/Error	FRU/Action
No beep, power-on indicator not on, and a blank LCD during POST.	1. Go to “Power Systems Checkout” on page 135. 2. Top System Board. 3. Power sources.
No beep, power-on indicator on, and a blank LCD during POST.	1. Top System Board. 2. Bottom System Board.
No beep, power-on indicator on, and a blinking cursor only during POST.	1. Top System Board. 2. Bottom System Board.
No beep during POST but system runs correctly.	1. Turn the volume up. 2. Speaker. 3. Top System Board.

LCD-Related (Video) Symptoms

Note that LCD-related symptoms might be a result of software problems. Therefore, before working on hardware to correct video problems, make sure that the system has the latest versions of the video drivers installed. Systems that do not have the latest versions of video drivers might experience symptoms such as random extra pixels.

Note: To check the versions of the video drivers, follow these steps:

- In DOS.

Drivers display their version level when they are loaded. To check them after they have been loaded, look in CONFIG.SYS or AUTOEXEC.BAT files for video driver information.

- In Windows.

Drivers installed using the video driver installation utility place an icon in the **Control Panel**, in the **Main** group. Double-click on the **ChipsCPL** icon to display the driver dialog box. Choose the **Version** button to display the driver level.

Symptom/Error	FRU/Action
No beep, power-on indicator on, and a blank LCD during POST.	<ol style="list-style-type: none"> 1. Adjust contrast. 2. Top System Board. 3. Bottom System Board.
<ul style="list-style-type: none"> • LCD backlight not working, or • LCD too dark, or • LCD brightness cannot be adjusted. 	<ol style="list-style-type: none"> 1. Reseat LCD connectors. 2. Reseat inverter card. 3. Inverter Card. 4. LCD Assembly.
LCD contrast cannot be adjusted (ThinkPad 701CS only).	<ol style="list-style-type: none"> 1. Reseat LCD connectors. 2. Top System Board. 3. LCD Assembly.
<ul style="list-style-type: none"> • LCD screen unreadable, or • Characters missing pels, or • Screen abnormal, or • Wrong color displayed. 	<p>[See important note for “Disassembling the LCD Assembly” on page 172.]</p> <ol style="list-style-type: none"> 1. Check that the latest versions of the drivers are installed. 2. Reseat LCD connectors. 3. Bottom System Board. 4. LCD Assembly.
LCD has extra horizontal or vertical lines displayed.	<ol style="list-style-type: none"> 1. LCD Assembly.
Blank LCD, system runs correctly during POST.	<ol style="list-style-type: none"> 1. Check display type. (Press Fn+F1 to enter the Configuration Utility, and then reset Display type to LCD.)

Keyboard and TrackPoint III Symptoms

Symptom/Error	FRU/Action
Keyboard (one or more keys) does not work.	<ol style="list-style-type: none"> 1. Reseat the two larger keyboard cables. 2. Keyboard. 3. Top System Board.
TrackPoint III does not work or the pointer moves automatically ("drifts") or does not work correctly.	<ol style="list-style-type: none"> 1. Go to "TrackPoint III Checkout" on page 132.

MultiPort II Related Symptoms

Before testing or replacing the MultiPort II, ensure that the customer installed the MultiPort II while the computer was powered-off or in Suspend mode. Make sure the problems occur when the MultiPort II has been installed correctly.

Symptom/Error	FRU/Action
Devices connected to the MultiPort II do not work correctly.	<ol style="list-style-type: none"> 1. Check the device connectors to make sure that they are connected correctly. 2. Check the cables to make sure they are not defective or damaged. 3. Go to "MultiPort II Checkout" on page 134.
Problems occur when the MultiPort II is connected or removed (unlatched).	<ol style="list-style-type: none"> 1. Verify that the MultiPort II is correctly seated and that the latches are engaged properly. 2. Go to "MultiPort II Checkout" on page 134.
Power problems occur when the MultiPort II is connected to the computer.	<ol style="list-style-type: none"> 1. Remove and then reattach the AC adapter to the computer or the MultiPort II. 2. MultiPort II. 3. Top System Board.

Indicator Related Symptoms

Symptom/Error	FRU/Action
Indicator incorrectly remains on or off, but system runs correctly.	<ol style="list-style-type: none"> 1. Reseat the inverter card. 2. Inverter Card. 3. Top System Board.
Battery status indicator blinks green and beeps three times at power-on or Resume.	<ol style="list-style-type: none"> 1. Check that a fully charged battery is installed. 2. Battery Pack 3. Reseat Top and Bottom System Boards together. 4. Top System Board. 5. Bottom System Board.
Battery status indicator blinks green at power-on.	<ol style="list-style-type: none"> 1. Check the card-to-card connection. Reseat Top and Bottom System Boards together. 2. Top System Board. 3. Bottom System Board.
Battery status indicator does not turn on when battery fuel gauge is over 90% but less than 100%.	<ol style="list-style-type: none"> 1. This is normal operation if charging continues. Leave the computer charging, and then recheck the battery fuel gauge a short time later to see whether the charge has increased.

Power Related Symptoms

Symptom/Error	FRU/Action
Power shut down during operation.	<ol style="list-style-type: none"> 1. Go to “Power Systems Checkout” on page 135. 2. Battery Pack 3. Power sources 4. Top System Board
The system will not power-off.	<ol style="list-style-type: none"> 1. If you are in Suspend mode, resume by pressing Fn. Then, try to power-off. 2. Disconnect the computer from ac power. 3. Remove the battery. 4. If problem occurs consistently, replace the Top System Board.

Symptom/Error	FRU/Action
Battery pack charges, but the battery status indicator does not light.	<ol style="list-style-type: none"> 1. Reseat the Inverter Card. 2. Replace the Inverter Card.
Battery pack does not charge, the battery status indicator does not light, and the battery fuel gauge is less than 90%.	<ol style="list-style-type: none"> 1. Check the AC adapter connection. Make sure that the computer is powered-on or in Suspend mode. 2. Check the Configuration Utility to ensure that the AC adapter is supplying the correct voltage level. 3. Check the AC adapter. 4. Make sure that the computer is within the operational temperature range. 5. Change the AC adapter. 6. Replace the Battery Pack. 7. Replace the Top System Board.

Function Related Symptoms

Symptom/Error	FRU/Action
The system will not enter Suspend mode or resume by opening or closing the LCD.	<ol style="list-style-type: none"> 1. Check the Configuration Utility to ensure that the Suspend on Lid Close function is enabled. 2. Check that the computer can enter Suspend mode by pressing Fn+F4. 3. Top System Board. 4. Bottom System Board.
Memory count (size) appears different from actual size.	<ol style="list-style-type: none"> 1. Go to “Memory Checkout” on page 128.
System configuration does not match the installed devices.	<ol style="list-style-type: none"> 1. Go to “Checking Installed Devices” on page 157.
System stops intermittently.	<ol style="list-style-type: none"> 1. Go to “Intermittent Problems” on page 152.

Infrared Related Symptoms

See “Infrared Transceiver Checkout” on page 137 for information on the infrared transceiver and infrared transceiver checkout.

Audio Related Symptoms

Symptom/Error	FRU/Action
You cannot hear any sound.	<ol style="list-style-type: none">1. In the Configuration Utility, check the volume level and the settings for Audio Power and Mute.2. Attach external speakers or headphones and check for sound:<ul style="list-style-type: none">• If the external speakers or headphones work, replace the internal speaker.• If the external speakers or headphones do not work, replace the Top System Board.
Internal microphone does not record.	<ol style="list-style-type: none">1. Check the application’s recording source and level.2. Attach an external microphone and check for recording:<ul style="list-style-type: none">• If the external microphone works, replace the internal microphone.• If the external microphone does not work, replace the Top System Board.
Other audio problems.	<ol style="list-style-type: none">1. Replace the Top System Board.

Peripheral Device Related Symptoms

Before testing or replacing any peripheral device, go into the Configuration Utility and ensure that all of the configurations are correct. Also, check applications to ensure that devices are configured correctly.

Symptom/Error	FRU/Action
External display does not work correctly.	<ol style="list-style-type: none">1. See “External Display Self-Test” in “Common Devices Checkout” section.
Printer problems.	<ol style="list-style-type: none">1. Run Printer self-test.2. Cable.3. Parallel Port Device.4. Top System Board.
Serial or parallel port device problems.	<ol style="list-style-type: none">1. Device.2. Device Cable.3. Top System Board.

Other Symptoms

Symptom/Error	FRU/Action
Errors occur only when MultiPort II is used	1. See "MultiPort II Checkout" on page 134.
PCMCIA slot pin is damaged.	1. Bottom System Board.

Note: If you cannot find a symptom or error in this list and the problem remains, see "Undetermined Problems."

Intermittent Problems

Intermittent system interruptions can be caused by a variety of reasons that have nothing to do with a hardware defect, such as electrostatic discharge or software errors. Consider replacing a FRU only when a recurring problem exists.

When analyzing the intermittent problem, perform the following steps:

1. Run the advanced diagnostics test in loop mode at least 10 times.
2. If no error is detected, do **not** replace any FRUs.
3. If any error is detected, replace the FRU shown by the FRU code. Rerun the test to verify that no more errors exist.

Undetermined Problems

Perform the following procedures to isolate the failing FRU if the diagnostics tests did not identify which adapter or device failed, or whether the installed devices are incorrect, a short circuit is suspected, or the system is inoperative.

Note: Do not replace a nondefective FRU.

Before performing these procedures, perform the following actions:

- Verify that all attached devices are supported by the computer.
 - Verify that the power supply being used at the time of the failure is operating correctly. (See "Power Systems Checkout" on page 135.)
1. Power-off the computer.
 2. Check the cables, wires, and connectors for short circuits and open circuits. Visually check them for damage. If any problems are found, replace the FRU.

3. Remove or disconnect all of the following devices:
 - a. Non-IBM devices
 - b. Devices attached to the expansion bus connector
 - c. Printer, mouse, and other external devices
 - d. Battery pack
 - e. Hard disk drive
 - f. Diskette drive or the device attached to the diskette drive connector
 - g. SO-DIMM card
 - h. PCMCIA cards

Note: Remember that removing the hard disk drive, a SO-DIMM card, or any adapter or device will cause configuration errors. Error code 162 will occur.

4. Power-on the computer.
5. Determine whether the problem has changed.
6. If the problem does not occur again, reconnect the removed devices one at a time until you find the failing FRU.
7. If the problem remains, replace the following FRUs one at a time.

Note: Do not replace a nondefective FRU.

- Inverter Card.
- LCD Assembly.
- Top System Board.
- Bottom System Board.

Related Service Procedures

Understanding Fn Key Combinations







The following table shows the **Fn** key and function key combinations and their corresponding functions.

The **Fn** key works independently from the operating system. The operating system obtains the status through the system management interface to control the system.

Fn+	Description
(alone)	Resumes operation from Suspend mode.
F1	Enters the Configuration Utility.
F2	Turns the battery-gauge icon on and off.
F3	Enters Standby mode.
F4	Enters Suspend mode.
F5	Mutes and unmutes speaker.
F6	Turns the hard disk off.
F7	Cycles through display options (LCD, CRT, both).
F8	Reverses video display.
F9	Reserved.
F10	Reserved.
F11	Reserved.
F12	Enters Hibernate mode.
Insert	Increases contrast. (This combination key does not provide this function on ThinkPad 701C as TFT screens do not require contrast adjustment.)
Delete	Decreases contrast. (This combination key does not provide this function on ThinkPad 701C as TFT screens do not require contrast adjustment.)
Home	Increases brightness.
End	Decreases brightness.
PgUp	Increases speaker volume, unmutes speaker.
PgDn	Decreases speaker volume.

Reading Status Indicators

The system status indicators show the current computer status in different colors (green and yellow).

Symbol	Color	Meaning
	Green	Battery charging.
	Blinking green	Battery low.
	Yellow	Hard disk drive in use.
	Green	Keys in NumLk mode.
	Green	Keys in Caps Lock mode.
	Green	Keys in ScrLk mode.
	Green	Computer powered on and not in Suspend mode.

Reading the Battery Status: If the computer is using the battery, the **Battery Status** field in the Configuration Utility indicates whether the battery is OK or low. If the computer is using external power, this field indicates whether the battery is fully charged or still charging. The battery fuel gauge provides a visual indication of the battery power level.

Understanding the Power-On Self-Test

Each time you power-on the computer, the power-on self-test (POST) is initiated. The POST takes up to 90 seconds to complete, depending on the options installed.

The POST checks the following items: system boards, memory, display, keyboard, diskette drive, hard disk drive, parallel port, and serial port.

To start the POST, power-on the computer. The following actions will happen:

1. If a critical error occurs during the POST, the system halts. The system might beep or display a message. If the POST cannot be completed successfully, an error code appears on the display, and you are prompted to press **Esc** or **Enter**. If you press **Esc**, the computer bypasses the error and attempts to complete the POST. If you press **Enter**, the computer displays the Configuration Utility window. You can then try to correct the error. (See "Running the Diagnostics" on page 156.)
2. The computer issues one short beep when the POST ends successfully.

3. The computer attempts to load the operating system as customized. If the computer does not find an operating system, it displays a graphic message requesting that you insert a bootable diskette in the diskette drive and press **F1** to resume operation.

Removing the Power-On Password

Important

This information is not available in this HMM online format. See your IBM Servicer or IBM Authorized Dealer for this procedure.

Running the Diagnostics

Use either the TrackPoint III or the cursor movement keys to interact with the tests. When asked for an "OK" response, press **Enter** or select the **OK** button.

1. With the computer powered-off, attach any test tools to the device to be tested. For example, attach a wrap plug to the serial port on the MultiPort II or insert the PC test cards in the PCMCIA slot.
2. Power-on the computer. Press the **F1** key any time while the POST memory count is proceeding. When the memory test is completed, the Easy-Setup screen appears.
3. Select **Test** and press **Enter**.
4. Press **Ctrl+A** to enter advanced diagnostics.
5. Select **Tool** to install a test tool.

Select the test tool for a device, and press the spacebar or click button to install it. A \checkmark mark appears for the selected device. Repeat this step to install multiple devices.

Note: A graphic message prompts you to attach the selected test tools.

6. Select **OK** and press **Enter** if the selection is correct.
7. Select a device and press **Enter** to start the tests.
8. Select **Test All** to test all devices.
9. Select **Looptest** to loop tests.

A loop option menu appears in which you can select a loop test for one or more devices. Select a device and press the spacebar or click key. A \checkmark mark appears for the selected device. Repeat this step to select multiple devices. Press **Enter** to start the diagnostics loop. If no device is selected, all device tests are looped.

10. To exit the loop, keep pressing **Ctrl+Pause** until the test exits. The system emits a beep sound to notify you that the test program has received the exit interrupt.
11. Press **Esc** to exit the test screen.
12. Choose **Restart** to leave Easy-Setup and restart your system.

13. Select **OK** or press **Enter** to confirm the restart.

Printing and Displaying Error Logs

Diagnostics errors are printed on the printer that is attached to the parallel port when the error is detected. The error is also logged in the system memory.

Use the following procedure to display the errors:

1. End the test, if it is running.
2. Press **Ctrl+A** to enter the advanced diagnostics.
3. Press **Ctrl+E**.
4. The error log appears.
5. To exit the screen, select **Cancel** or press **Esc**.

The error log is not saved when system power is turned off.

Checking Installed Devices

Installed devices are displayed as dark icons on the diagnostics screen. All other devices are displayed with gray icons.

If a device is installed but the icon appears gray rather than dark, the device is defective. Reseat the device connectors, and then restart diagnostics. If the symptom remains, replace the device or the system board. If needed, adjust the contrast control to clearly distinguish the shades of the icon.

If a device that is not installed appears in a dark shade, for example, if HDD-2 appears in a dark shade when a second hard disk drive is not installed, perform the following steps:

1. Replace the *first* device, such as HDD-1.
2. If the problem persists, replace the relevant system board.

The PCMCIA, System Board, Display, and infrared transceiver icons are always displayed in a dark shade, because the icons represent subsystems of the system board and not attached devices. The parallel port icon is dark except when the diskette drive is attached to the parallel port; in that case, the FDD icon is dark and the parallel port icon is gray. Icons for devices attached through the MultiPort II are dark when the devices are attached, and are gray when the devices are removed from the MultiPort II.

The HDD-1 icon represents the *first* drive in the system configuration. Similarly, the HDD-2 icon represents the *second* drive, attached to the docking station.

Running the Low-Level Format

Perform the following steps to format the hard disk:

Warning: All data and formatting on the disk will be destroyed and cannot be recovered. Have the user make a backup copy of all information on the hard disk that should be saved. Make sure that a bootable diskette is available. Make sure that the drive address to be formatted is correct.

Use either the TrackPoint III or the cursor movement keys to interact with the tests. When asked for an "OK" response, press **Enter** or select the **OK** button.

1. Power-off the computer, and then power it on again.
2. Press the **F1** key any time while the POST memory count is proceeding. When the memory test is completed, the Easy-Setup screen appears.
3. Select **Test** and press **Enter**.
4. Press **Ctrl+A** to enter advanced diagnostics.
5. Press **Ctrl+F**. The **Format** icon appears at the top of the advanced diagnostics screen.
6. Select the **Format** icon and press **Enter**.
7. Select the hard disk to be formatted and press **Enter**.
8. A confirmation screen appears, showing the number of cylinders, heads, and sectors on the hard disk.
9. Press **Esc** to exit the low-level format screen without formatting the hard disk.
10. Press **Enter** to begin the low-level format of the hard disk. When the low-level format is completed, the advanced diagnostics screen is displayed.
11. When you restart the computer, a graphic message is displayed at the end of POST, requesting that you insert a bootable diskette into the diskette drive and press **F1** to resume operation.

Reading the PC Test Card LED

The green LED on a PC test card (JEIDA/PCMCIA wrap card) turns on when the PCMCIA test is running. If the LED does not turn on, check that the card is installed correctly by reseating the card. If it still does not turn on after the card is reseated and you are using one PC test card, try using the other slot for the test. If you are using two cards, try swapping the cards in the slots. If the LED still does not turn on and the test fails, replace the FRU shown in the diagnostics error code.

Removing PCMCIA Cards

After removing the PCMCIA cover, and filler plug if it is installed, you can insert or remove PCMCIA cards during most computer operations.

To insert a PCMCIA card, perform the following steps:

1. Insert the PCMCIA card into one of the available slots, with the long row of pin sockets facing the computer and the label on the PCMCIA card facing up. When the card is in place, the blue eject button at the left of the slot pops out. Do not force the card. If the card does not fit into the slot, turn it over.

Note: A Type III PCMCIA card occupies both PCMCIA slots. To insert the card, aim its bottom ridges at the lower PCMCIA card slot.

2. Replace the outer cover over the PCMCIA slots.

To remove a PCMCIA card, perform the following steps:

1. Use a small pointed object such as the point of a pen to press the blue eject button located to the left of the PCMCIA card slot.

Note: A Type III PCMCIA card occupies both PCMCIA slots. To remove the card, press the bottom eject button.

2. Carefully slide the PCMCIA card out of the slot.
3. If both PCMCIA slots are empty, replace the filler plug and replace the outer cover over the PCMCIA slots.

Note: Do not remove PCMCIA cards while the system is in Suspend or Hibernate mode. If you remove a PCMCIA card while the system is in either mode, you might lose configuration information. Or, if you remove a PCMCIA card and insert another card, your system might not recognize the new card.

Product Overview

The following table provides a brief overview of the system features.

Feature	Description
Processor	Intel** 486** DX2 25/50MHz or DX4 25/75MHz, with math coprocessor.
Memory (Standard)	4MB or 8MB (on the system board).
Memory (Optional)	4, 8, or 16MB SO-DIMM.
Bus Architecture (Two Busses)	<ul style="list-style-type: none">• Local bus for hard drive and video (with hardware line draw, BITBLT, cursor, and sprite support).• ISA bus









Feature	Description
CMOS RAM	128 Bytes.
VGA Video	<ul style="list-style-type: none"> <li data-bbox="301 312 718 394">• ThinkPad 701CS 10.4-inch, 640 × 480, 256/226K color, DS-STN LCD color. <li data-bbox="301 396 718 478">• ThinkPad 701C 10.4-inch, 640 × 480, 256/226K color, TFT LCD color.
Diskette Drive	1.44MB (3-mode for Japan, 2-mode for other countries) 3.5-inch external.
Hard Drive (Removable)	<ul style="list-style-type: none"> <li data-bbox="301 566 501 594">• 360MB, 2.5-inch <li data-bbox="301 596 501 625">• 540MB, 2.5-inch <li data-bbox="301 627 601 656">• 720MB, 2.5-inch (optional)
Audio	<ul style="list-style-type: none"> <li data-bbox="301 658 493 686">• Built-in speaker <li data-bbox="301 688 536 717">• Built-in microphone. <li data-bbox="301 719 508 748">• Microphone jack. <li data-bbox="301 750 591 778">• Speaker/headphone jack. <li data-bbox="301 780 459 809">• Line-in jack. <li data-bbox="301 811 664 854">• Supports SoundBlaster** and SoundBlaster Pro** applications.
Internal Modem Card	Data/Fax/Voice Modem with 14.4 Kbps transmission rate and telephony support (U.S. and Canada only).
PCMCIA Cards	<p data-bbox="288 958 576 987">Accepts any of the following:</p> <ul style="list-style-type: none"> <li data-bbox="301 999 526 1028">• One or two Type I. <li data-bbox="301 1030 532 1058">• One or two Type II. <li data-bbox="301 1060 622 1089">• One Type I and one Type II. <li data-bbox="301 1091 470 1120">• One Type III.
Infrared Transceiver	Integrated infrared hardware IRDA-compatible transceiver with 115.2 Kbps transmission rate.



FRU Removals and Replacements

This section contains information about removals and replacements.

Follow the numerical sequence in “Disassembling the ThinkPad 701C/701CS” on page 163 and the three exploded views to remove or disconnect parts in the correct order. Reverse the numerical sequence to replace FRUs. Note exceptions and special instructions for replacement throughout the FRU removal procedure.

The letters in parentheses in the list indicate screw types. Consult the following screw size chart to match the letters to the correct screw type and size before replacing each screw.

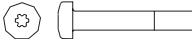
BA	Nut, M2.5	Silver
		
BC	M2.5, 6 mm	Black
		
BD	M2.5, 8.4 mm	Black
		
BE	M2.5, 10 mm	Black
		
BF	M1, 3 mm	Black
		
BG	M2.5, 7.5 mm	Black
		
BH	M2.5, 8 mm	Black
		
BI	M2.5, 5 mm	Black
		
BJ	M2, 8 mm	Silver
		

BK	M2.5, 16 mm	Black
		
BL	M2.5, 6 mm	Black
		
<p>Note:</p> <ol style="list-style-type: none"> 1. Use a TORX** T1 screwdriver on the BF screw. Torque to 0.5 in./lb. 2. For the other listed screws, use a TORX T6 screwdriver. Torque to 2.5 in./lb. 		

Safety Notice 8: Translation on page 13

Before removing any FRU, power-off the computer, unplug all power cords from electrical outlets, remove the battery pack, then disconnect any interconnecting cables.

Safety Notice 1: Translation on page 7

Before the computer is powered-on after FRU replacement, make sure all screws, springs, or other small parts are in place and are not left loose inside the computer. Verify this by shaking the computer and listening for rattling sounds. Metallic parts or metal flakes can cause electrical shorts.

Note: Before removing any FRU, remove any attached devices, including the diskette drive, diskette drive cable, and MultiPort II if they are attached.

Safety Notice 2: Translation on page 8

Some standby batteries contain a small amount of nickel and cadmium. Do not disassemble it, recharge it, throw it into fire or water, or short-circuit it. Dispose of the battery as required by local ordinances or regulations. Use only the battery in the appropriate parts listing when replacing the RTC or backup battery. Use of an incorrect battery can result in ignition or explosion of the battery.

Disassembling the ThinkPad 701C/701CS

This procedure provides the steps required to completely disassemble the ThinkPad 701C/701CS.

The three exploded views show the parts of the computer that are removed at various stages of the disassembly process. The numbered callouts in the figures correspond to steps in the procedure.

ThinkPad 701C/701CS Exploded View

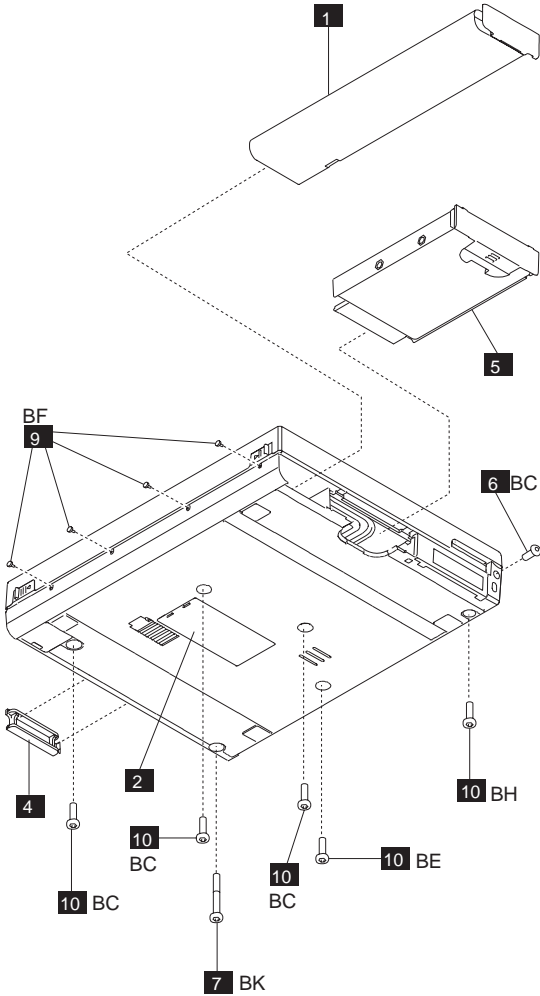

ThinkPad 701C/701CS Exploded View

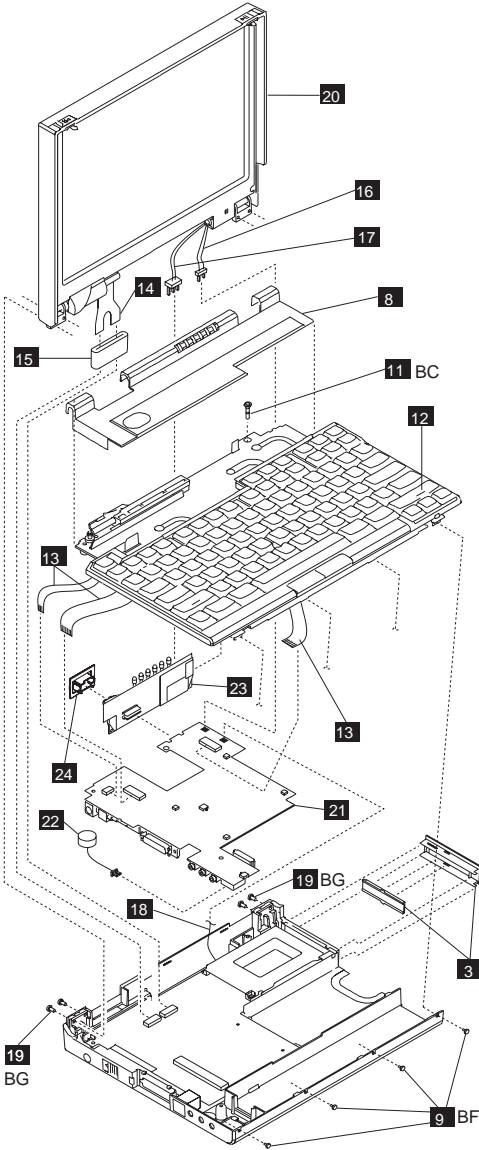

ThinkPad 701C/701CS Exploded View

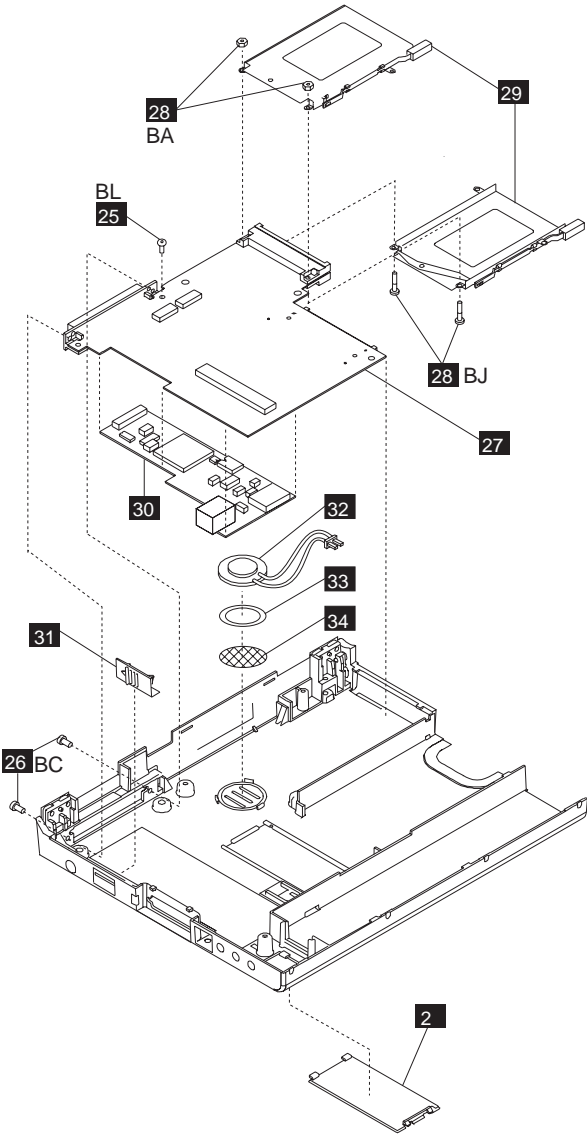

If you follow all of the steps in this procedure, you completely disassemble the ThinkPad 701C/701CS.

However, for some replacement operations, you may not need to completely disassemble the ThinkPad 701C/701CS. In those situations, the relative sequence of steps in this procedure is important. Some FRUs must be removed to reach the failing FRU, or to make it easier to work with another FRU.

This procedure contains instructions for the following:

- Removing the Keyboard Cover
- Removing the Keyboard
- Separating the Display and Base Units
- Removing the Top System Board and Inverter Card
- Removing the Bottom System Board and Modem
- Taking Apart the Base Assembly

1 Remove the battery shown in the figure on page 163.

2 Remove the SO-DIMM cover and any installed SO-DIMM cards, shown in the figure on page 163.

See “Removing and Replacing the SO-DIMM Card” on page 178 for more detailed information.

3 Remove the PCMCIA cover and filler plug shown in the figure on page 164. Remove any installed PCMCIA cards.

See “Removing PCMCIA Cards” on page 159 for more detailed information.

4 Remove the parallel port cover, shown in the figure on page 163.

Warning: Do not drop or apply any shock to the hard disk drive. The hard disk drive is sensitive to physical shock. Incorrect handling can damage it and cause permanent loss of data on the hard disk. Before removing the hard disk drive, have the user make a backup copy of all the information on the hard disk. Never remove the hard disk drive while the system is operating or while it is in Suspend mode.

5 Remove the hard disk drive, shown in the figure on page 163.

Note: Remove the hard disk drive by inserting a coin in the slot and twisting until the hard disk drive is unseated. Do not apply any extra force to the hard disk drive when removing it.

Removing the Keyboard Cover

6 Remove the screw (BC) located on the right side toward the back of the computer, shown in the figure on page 163.

7 Remove the screw (BK) located on the rear bottom left of the computer shown in the figure on page 163.

8 Open the computer lid all the way (180°) and remove the keyboard shelf, shown in the figure on page 164.

To release the keyboard shelf from the base assembly:

1. Gently pull up on the right side of the keyboard shelf.
2. Insert a tool into the slots on the back of the computer and gently push in to release the tabs holding in the shelf.

Removing the Keyboard

9 Remove the four screws (BF) located on the front, below the keyboard, shown in the figures on pages 163 and 164.

10 Remove the five remaining screws from the bottom of the base.

(For the screw types that are removed in this step, see the figure on page 163.)

Replacement:

Warning: When you reinstall the screws, be careful when tightening the middle screw toward the rear of the computer. If you tighten the screw too much, you can break the plastic base. If you are using an electric screwdriver, set it to a low or sensitive setting to prevent breakage.

11 Remove the screw (BC) located below the right hinge.

Replacement: When you replace the screws in the base and the keyboard shelf, perform the steps in the following order:

1. Replace the screw (BC) in step **11** shown in the figure on page 164. Do not tighten the screw until the front keyboard screws are in place.
2. Replace the keyboard shelf.
3. Replace the front keyboard screws in step **9** shown in the figure on page 163.
4. Tighten the BC screw.
5. Replace the screws in step **10**.

12 Remove the keyboard, shown in the figure on page 164.

To remove the keyboard, push it backward slightly, and then pull it up, then forward and out.

Replacement: When you reinstall the keyboard, follow these steps:

Warning: When you reinstall the keyboard, be careful not to damage the keyboard cables by pinching or crushing them.

1. Attach the three flat cables.
2. Tilt the front of the keyboard up and push the rear of the keyboard toward the back of the computer.
3. Press the keyboard down.
4. Pull the keyboard slightly forward to engage the latches located at the back right, and in the middle of the left and right sides.

Warning: Do not pull out the cable before releasing the sliding latch connector.

13 Detach the three keyboard cables from the top system board shown in the figure on page 164.

The keyboard cables use zero insertion force (ZIF) connectors.

Instructions for working with ZIF connectors:

To detach the cables, pull out the small sliding latch under each cable using a small tool to pull on each side. Try to pull the latch out incrementally on each side, or pull out both sides simultaneously.

Replacement: When you reinstall cables in ZIF connectors, insert the cable connector end, metal side facing up, into the connector, and then gently push in each sliding latch to secure the cable. Do not twist the cables.

Warning: Do not pull out the cable before releasing the sliding latch connector.

Separating the Display and Base Units

14 Detach the LCD cable shown in the figure on page 164.

Slide up the ferrite core on the cable to reach the latches.

The LCD cable uses ZIF connectors.

Replacement: For information about reconnecting the LCD cable, see “Replacing the LCD Assembly” on page 175.

15 Remove the ferrite core from the LCD cable shown in the figure on page 164.

Replacement: For information about replacing the ferrite core, see “Replacing the LCD Assembly” on page 175.

16 Detach the microphone cable from the top system board, shown in the figure on page 164.

Replacement: Make sure that the two aluminum spacers are in place. After you reattach the microphone cable, place any excess cable behind the PCMCIA slot assembly. For information on

routing the backlight cable, see “Routing the Backlight Cable” on page 176.

- 17 Detach the LCD backlight cable from the inverter card, shown in the figure on page 164.**

Replacement: For information on routing the backlight cable, see “Routing the Backlight Cable” on page 176.

- 18 Detach the speaker cable from the top system board, shown in the figure on page 164.**

Replacement: After you reattach the speaker cable, place any excess cable behind the PCMCIA slot assembly.

- 19 Remove the four hinge screws (BG) shown in the figure on page 164.**

Close the computer lid before removing the screws.

- 20 Remove the LCD assembly, shown in the figure on page 164.**

Replacement: See “Disassembling the LCD Assembly” on page 172 for instructions on FRU removals and replacements for the LCD assembly. See “Replacing the LCD Assembly” on page 175 for instructions on replacing the LCD assembly.

Removing Top System Board and Inverter Card

- 21 Remove the top system board and the attached standby battery and inverter card, shown in the figure on page 164.** Reuse the rubber spacers.

Separate the metal spacers between the top and bottom system boards. Gently pull up the front of the top system board and insert a tool at the slot located near the battery connector. Press down with the tool and gently pry up to detach the top system board from the bottom system board.

Replacement: See “Replacing the Top System Board” on page 178 for information about replacing the top system board.

Safety Notice 3: Translation on page 9

The battery pack contains small amounts of nickel. Do not disassemble it, throw it into fire or water, or short-circuit it. Dispose of the battery pack as required by local ordinances or regulations. Use only the battery in the appropriate parts listing when replacing the battery pack. Use of an incorrect battery can result in ignition or explosion of the battery.

- 22 Remove the standby battery, shown in the figure on page 164.**

Replacement: When you replace the standby

battery, fold the cable and place the standby battery in the space beside the battery pack connector.

Safety Notice 6: Translation on page 12

To avoid shock, do not remove the plastic cover that surrounds the lower portion of the inverter card.

23 Remove the inverter card from the top system board, shown in the figure on page 164.

24 Remove the infrared window from the inverter card, shown in the figure on page 164.

Removing Bottom System Board and Modem

25 Remove the screw (BL) holding in the bottom system board, shown in the figure on page 165.

26 Remove the two screws (BC) located on the docking connector shown in the figure on page 165.

Replacement: When you replace these screws, use the following order:

1. Install one docking connector screw.
2. Install the bottom system board screw (from step **25**).
3. Install the other docking connector screw.

Safety Notice 4: Translation on page 10

The backup battery is a lithium battery and can cause a fire, explosion or severe burn. Do not recharge it, remove its polarized connector, disassemble it, heat it above 100 degrees C (212 degrees F), incinerate it, or expose its cell contents to water. Dispose of the battery as required by local ordinances or regulations. Use of an incorrect battery can result in ignition or explosion of the battery. Replacement batteries can be ordered from IBM or IBM Authorized Dealers.

27 Remove the bottom system board and the attached modem shown in the figure on page 165.

To remove the bottom system board, push in lightly on the modem connector to free it from the base. Make sure that the modem connector has been freed from its slot in the base before removing the bottom system board.

Replacement: When you replace the bottom system board, keep the speaker cable toward the rear of the computer. Do not leave it folded under the bottom system board. Reuse the rubber spacers.

28 Remove the two bolts (BJ) and nuts (BA) holding the PCMCIA slot assembly to the bottom system board, shown in the figure on page 165.

29 Remove the PCMCIA slot assembly, shown in the figure on page 165.

30 Remove the modem shown in the figure on page 165.

The modem is held in place with an adhesive gasket. You may need to pry gently on the modem to remove it from the bottom system board. When you reinstall the modem, you may need to apply a new adhesive gasket.

Taking Apart the Base Assembly

31 Remove the power switch cover, shown in the figure on page 165.

Warning: The speaker can magnetize metal and corrupt a diskette.

Warning: A scratch can damage the speaker. Be careful not to damage it with screwdrivers, screws, or other objects.

32 Remove the speaker, shown in the figure on page 165.

After you have removed the speaker, carefully remove any metal particles that might have flaked off.

33 Remove the adhesive gasket shown in the figure on page 165.

Replacement: Follow these steps in order:

1. Remove the old adhesive gasket and apply a new one to the base.
2. With the front of the base facing you, rotate the speaker so that the speaker wires are at "one o'clock," then attach the speaker to the gasket.
3. Position the speaker cable under the bottom system board and between the inverter card and the top system board to the connector on the top system board.

34 Remove the screen over the speaker, shown in the figure on page 165.

If the screen over the speaker is damaged, replace it.

Disassembling the LCD Assembly

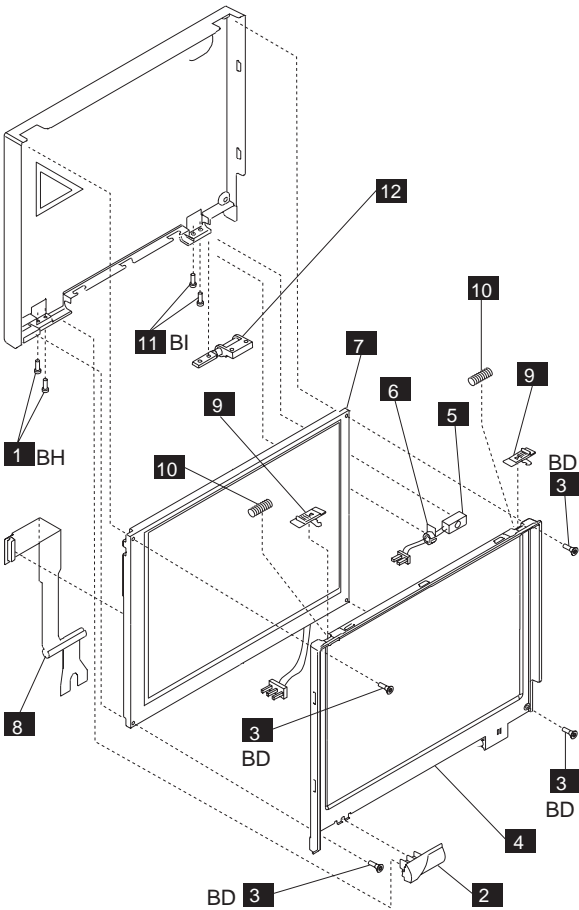

Safety Notice 5: Translation on page 11

If the LCD breaks and the fluid from inside the LCD gets into your eyes or on your hands, immediately wash the affected areas with water for at least 15 minutes. Seek medical care if any symptoms from the fluid are present after washing.

- 1** Remove the two bottom screws (BH).
- 2** Remove the left hinge cover (cam).
- 3** Remove the four bezel screws (BD).

- 4 Carefully unsnap the T-shaped snaps along the bottom edge of the bezel, and lift it out.

Be sure to use the correct replacement bezel for the LCD.

The TFT bezel has adhesive on its top side wall. When you install a new TFT bezel, remove the backing first.

- 5 Remove the microphone.
- 6 Remove the backlight cable protective sleeve.

Replacement:

For detailed information about replacing the microphone and sleeve, see “Replacing the Microphone and Sleeve” on page 174.

- 7 Remove the LCD.

When you replace the LCD, be sure to replace it with the correct type of LCD (STN or TFT).

- 8 Remove the LCD cable from the LCD.

- 9 Remove the latches from the bezel.

- 10 Remove the latch springs from the latches.

Replacement:

When replacing the latches, place the latch in the bezel, and then slide the spring over the post on the latch. Compress the spring slightly and slip it into the recess in the bezel.

- 11 Remove the two right hinge screws (BI).

- 12 Remove the right hinge.

The left hinge is part of the top cover assembly, and should be replaced with it as a unit.

Note: To clean the LCD, use rubbing alcohol and a soft cloth.

To avoid damaging the LCD, do not scratch or apply any force to its surface.

Important

The LCD for the ThinkPad 701C contains over 921 000 thin film transistors (TFTs). A small number of missing, discolored, or lighted dots (on all the time) is characteristic of TFT LCD technology, but excessive pixel problems can cause viewing concerns. The LCD should be replaced if the number of missing or discolored, or lighted dots in any background is 21 or more.

Replacing the Microphone and Sleeve

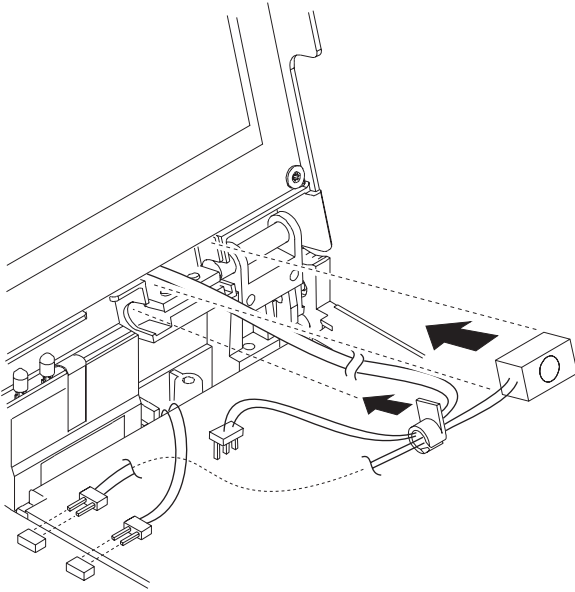

The right hinge should already be installed. To replace the microphone and cables, perform the following steps:

1. Insert the microphone wires into the small slit in the backlight cable protective sleeve.
2. Holding the microphone and sleeve near the hinge, insert the yellow backlight cable through the slit in the sleeve, and then the brown cable. Do not allow the microphone cable to twist around the backlight cables.
3. Slip the sleeve into place so that the flange is inside the computer lid, toward the LCD.
4. Insert the microphone into the space between the hinge and the LCD, with the foam block against the right side of the space. Press the block gently to ensure that it is completely inserted.

Make sure that the foam does not cover the microphone diaphragm. When installed correctly, the microphone lines up with the two small slots in the bezel.

Replacing the LCD Assembly

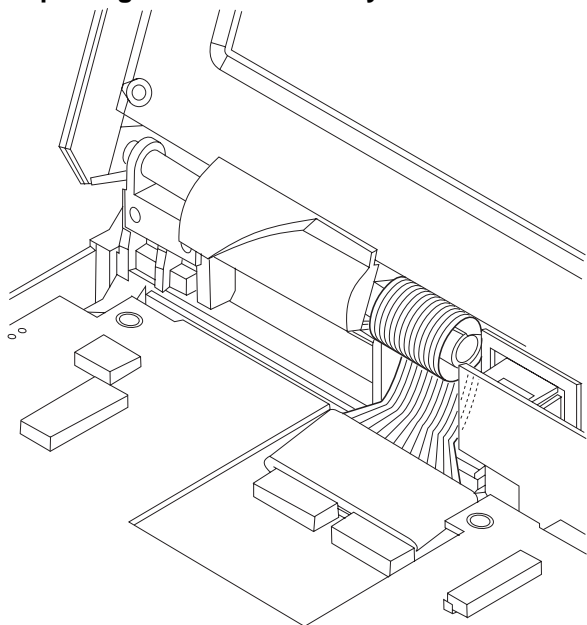

To reattach the LCD assembly, follow these steps:

1. With the LCD cable flat, carefully wrap the end of the LCD cable around the attached sleeve on the cable, finishing with the end of the cable coming from behind the sleeve.
2. To prevent possible damage, tape the end of the cable to the bezel while you reattach the LCD assembly.
3. Place the LCD assembly on the base in the closed position. Make sure that the backlight and microphone cables are *inside* the base unit.
4. Replace the four hinge screws (BG).
5. Open the computer lid all the way (180°) and remove the tape from the LCD cable.
6. Slide the ferrite core over the end of the LCD cable, pushing the core onto the cable just far enough to expose the two sets of silver contacts on the cable.
7. Connect the LCD cable to the connectors on the bottom system board by inserting the flat ends of the cable. Then, push in the small sliding latch under each cable to secure the cable in the connector. Do not bend or fold the LCD cable. Press on the loop of cable around the sleeve to insert the cable ends into the connectors.
8. Pull the ferrite core forward on the cable until the core touches the connectors and it can be pressed down flat on top of the bottom system board.

Routing the Backlight Cable

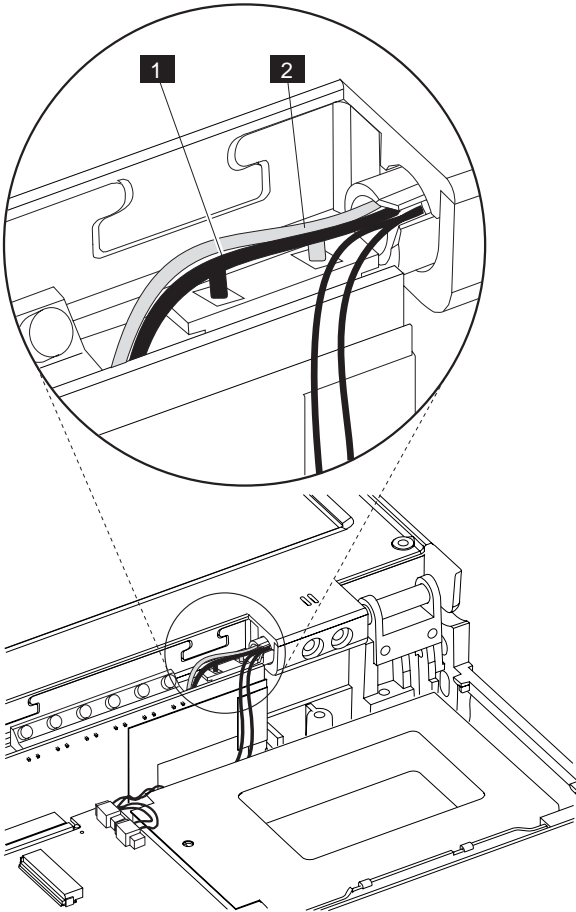

- 1** Brown wire.
- 2** Yellow wire.

Warning: Incorrect routing of the backlight cable may cause it to break after repeated opening and closing of the computer lid. Routing the cable correctly is important to prevent this breakage.

To route the backlight cable, follow these steps:

1. Plug the LCD backlight cable into the inverter card. Do not twist the wires.
2. Position the brown wire behind the connector so that after it exits the connector housing, it goes down between the inverter card and back wall of the base cover. (It must be outside of the inverter insulator.)
3. Loop the brown wire toward the LEDs and over the top of the connector.

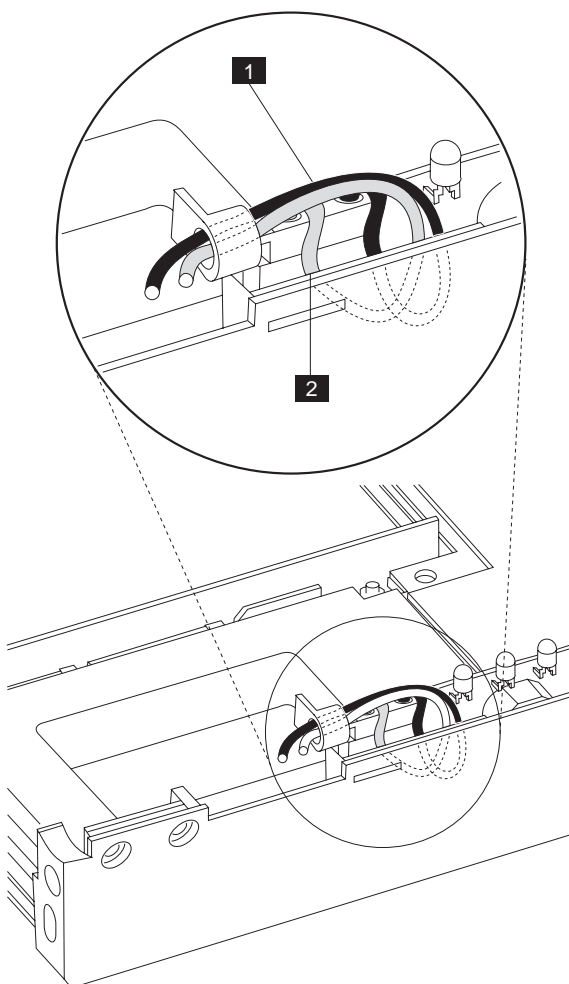

Backlight cable routing from the rear, shown without the computer lid.

- 1** Brown wire.
- 2** Yellow wire.

4. Route the yellow wire in the same manner as the brown wire. Position the yellow wire beside the brown wire where it runs over the connector on the side toward the back of the computer. Do not allow the wires to cross.
5. Be careful to keep the cable in the correct position as you complete the assembly of the computer.

Replacing the Top System Board

Perform the following steps when you replace the top system board:

1. Before inserting the top system board, move the power switch cover forward toward the front of the base assembly. Make sure that the spring in the power switch is fully inside the plastic housing.
2. Insert the top system board, tilting the board to the left and aligning the appropriate connectors with the slots on the base assembly. Be careful to align the power switch cover with the switch mechanism on the board.
3. Gently press the battery pack connector down to place the connector in the slot on the base assembly.
4. Ensure that the inverter card is firmly attached to the top system board, and that the infrared window is attached to the inverter card. The infrared window has a top and bottom. Install the window with the long side with the partial cutout facing the top of the inverter card.
5. Feed the speaker cable between the inverter card and the top system board to the right of the inverter card connector to the board.
6. As you press lightly down on the top system board and the inverter card, slip the bottom corners of the inverter card into the slots in the base assembly.
7. Gently but firmly press on the middle of the top system board to finish inserting the board and to ensure a complete connection between the board-to-board connectors.

Removing and Replacing the SO-DIMM Card

Warning: The SO-DIMM card is sensitive to physical shock. Incorrect handling of the card can damage it.

To remove a SO-DIMM card, follow these steps:

1. Power-off the computer.
2. Remove the battery.
3. Disconnect all cables and other devices, including the AC adapter.
4. Close the computer and turn it upside down.
5. Open the SO-DIMM door.

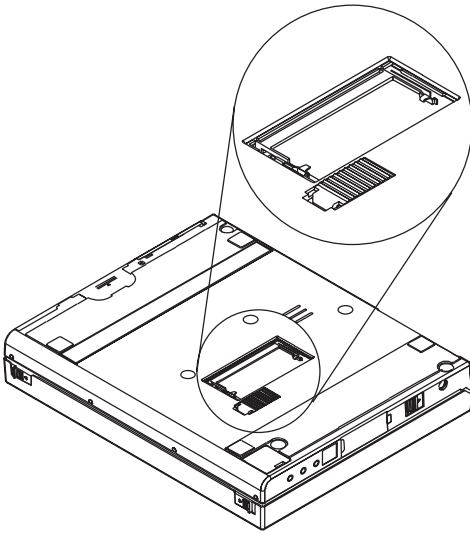

6. Press the metal tabs on each side of the SO-DIMM away from the card. The card should raise slightly as the tabs are pulled away from it.
7. Remove the card by holding it at a 15 to 20 degree angle and pulling it firmly away from the SO-DIMM socket.
8. Replace the SO-DIMM door.
9. Reattach all cables and other devices, including the AC adapter.
10. Power-on the computer. The computer will display error code 164.

To insert a SO-DIMM card, follow these steps:

1. Power-off the computer.
2. Remove the battery.
3. Disconnect all cables and other devices, including the AC adapter.
4. Close the computer and turn it upside down.
5. Remove the SO-DIMM door.
6. Locate the notch on the SO-DIMM.

Warning: Do not insert the SO-DIMM too far. You might damage the SO-DIMM or SO-DIMM socket.

7. Position the card at a 15 to 20 degree angle to the SO-DIMM socket with the notch facing to the right when you are looking into the socket, and push it into the socket firmly.
8. The card is fully inserted when the gold connectors are almost completely concealed by the SO-DIMM socket and only the top of each connector is visible.

Warning: The card will not lock into place if it has not been fully inserted into the socket.

9. Once the card is fully inserted into the socket, press the card down until it locks into place. It is held in place by two tabs, one on either side of the card.

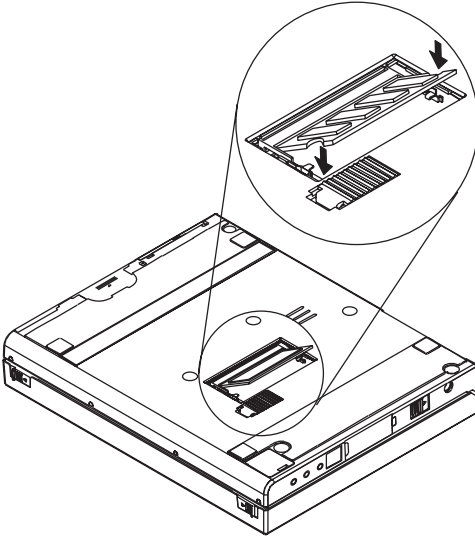

10. Replace the SO-DIMM door.
11. Reattach all cables and other devices, including the AC adapter, and power-on the computer.
12. Verify that the memory count displayed during the POST is correct. (See “Memory Checkout” on page 128 for information on memory size.)

Locations

System (Front View)

- 1** Latches
- 2** LCD
- 3** Keyboard
- 4** Click Buttons
- 5** TrackPoint III
- 6** Fn Key
- 7** Status Indicators

See "Reading Status Indicators" on page 155.

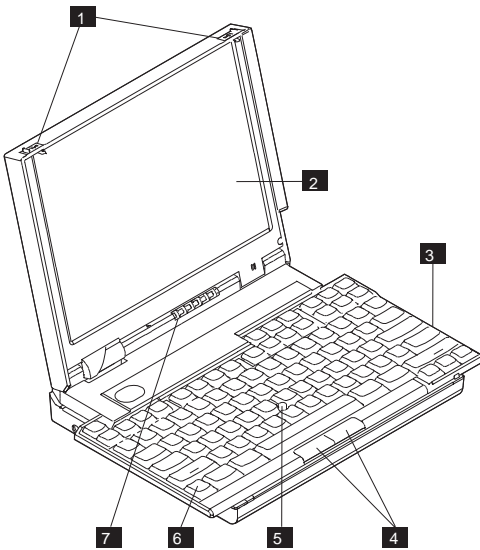

System (Left Side View)

- 1** Power Jack
- 2** Power Switch
- 3** Parallel/Diskette Drive Connector
- 4** Microphone-In Jack
- 5** Line-In Jack
- 6** Headphone-/Speaker-Out Jack

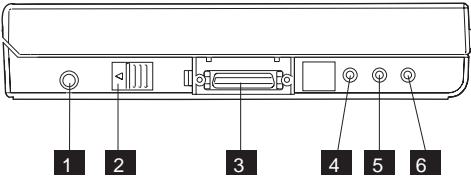

System (Right Side View)

- 1** Battery Pack
- 2** Hard Disk Drive
- 3** PCMCIA Access Port
- 4** Slot for Kensington Lock

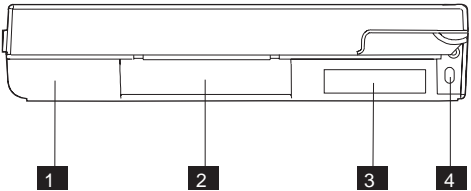

System (Rear View)

- 1** Latches
- 2** System Expansion Connector
- 3** Docking Door

A MultiPort II or Dock II can be connected to this interface to support the following features:

- 16-bit AT-bus interface
- Serial port
- Parallel port
- Keyboard and mouse
- Hard disk drive connection
- LED control signals
- Video signals
- Audio signals
- Diskette drive
- PCMCIA
- Power controls
- Power line

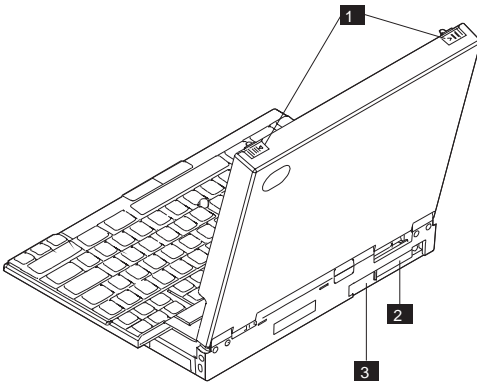

Top System Board (Top View)

- 1** Keyboard Connectors
- 2** Inverter Card Connector
- 3** Microphone Connector
- 4** Speaker Connector
- 5** Battery Pack Connector
- 6** Lid Close Sensor
- 7** Parallel/Diskette Drive Connector
- 8** TrackPoint III Connector

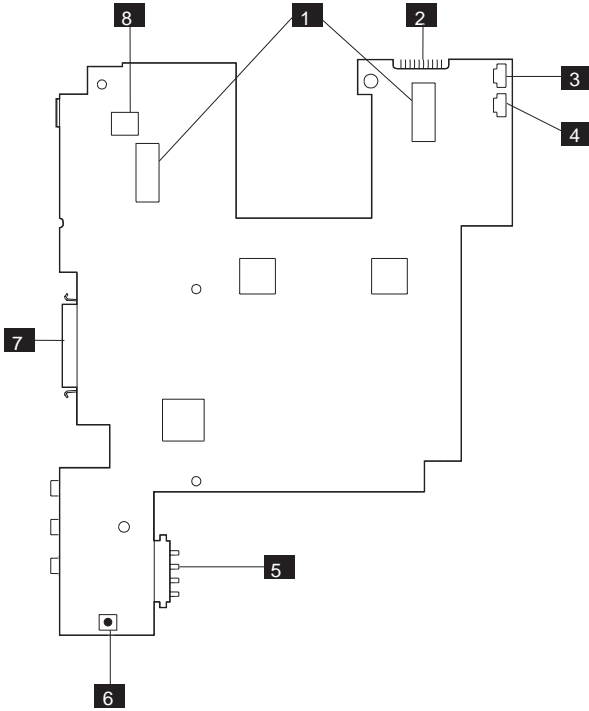

Top System Board (Bottom View)

- 1** Inverter Card Connector
- 2** Power Jack
- 3** Power Switch
- 4** Parallel/Diskette Drive Connector
- 5** Microphone-In Jack
- 6** Line-In Jack
- 7** Headphone-/Speaker-Out Jack
- 8** Standby Battery Connector
- 9** Battery Pack Connector
- 10** Board-to-Board Connector

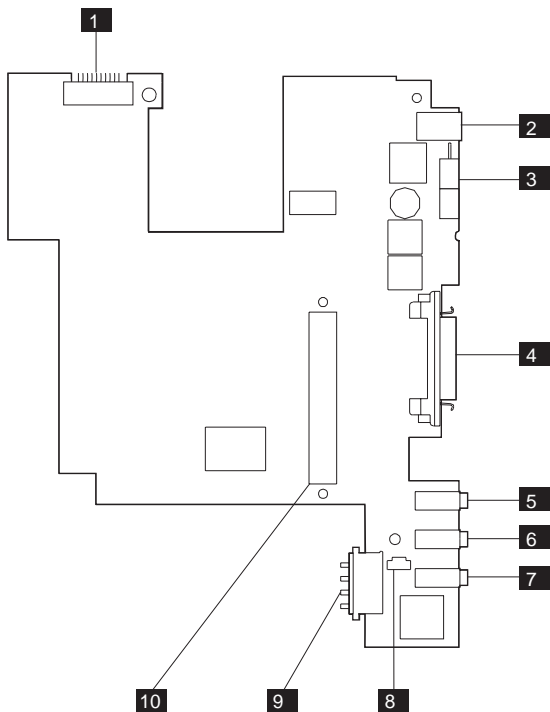

Bottom System Board (Top View)

- 1** System Expansion Connector
- 2** LCD Connectors
- 3** PCMCIA Controller
- 4** PCMCIA Slots
- 5** System Controller
- 6** Board-to-Board Connector
- 7** Video Controller

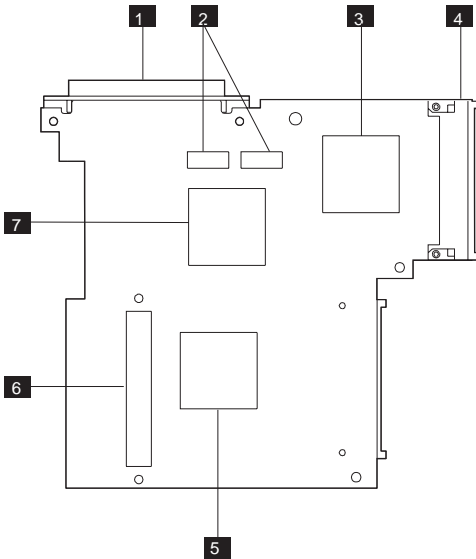

Bottom System Board (Bottom View)

- 1** PCMCIA Connector
- 2** Processor
- 3** System Expansion Connector
- 4** Modem Connector
- 5** Random Access Memory
- 6** SO-DIMM Connector
- 7** Hard Disk Drive Connector
- 8** RTC Battery
- 9** Power-On Password Bypass Pads

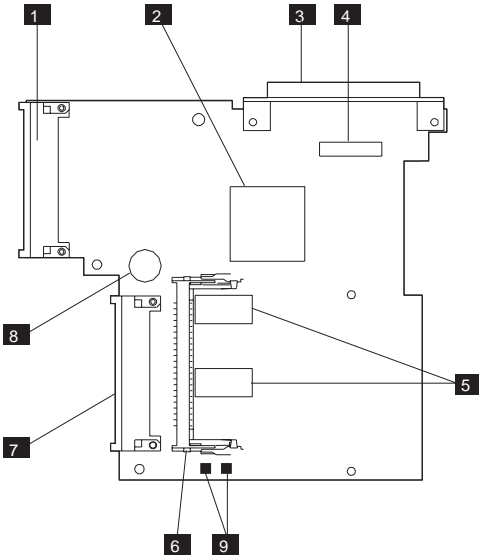

Inverter Card (Front View)

- 1** Light-Emitting Diodes
- 2** System Board Connector

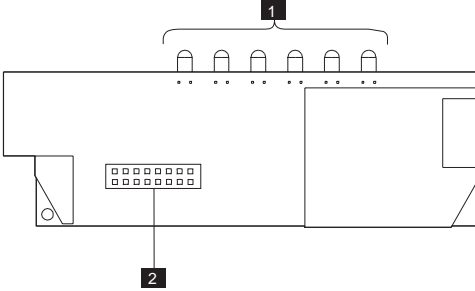

Inverter Card (Rear View)

- 1** Light-Emitting Diodes
- 2** Infrared Serial Port
- 3** LCD Connector

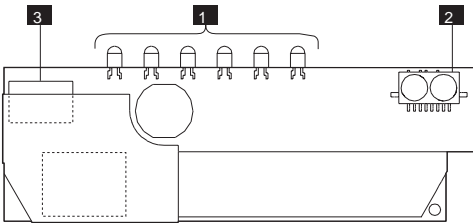

MultiPort II (Front View)

- 1 Port Connector

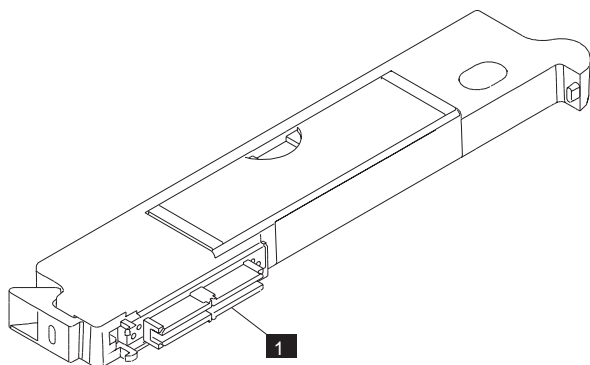

MultiPort II (Rear View)

- 1 Release Lever
- 2 External Display Port
- 3 AC Adapter Port
- 4 External Mouse/Numeric Keypad Port
- 5 External Keyboard Port
- 6 Audio Out
- 7 Audio In
- 8 Parallel Port
- 9 Serial Port

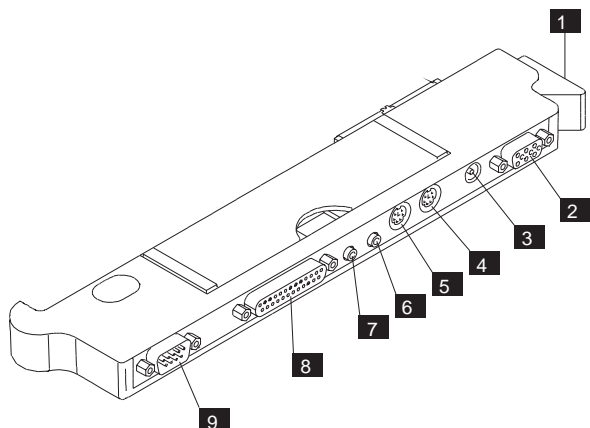

Parts Listing

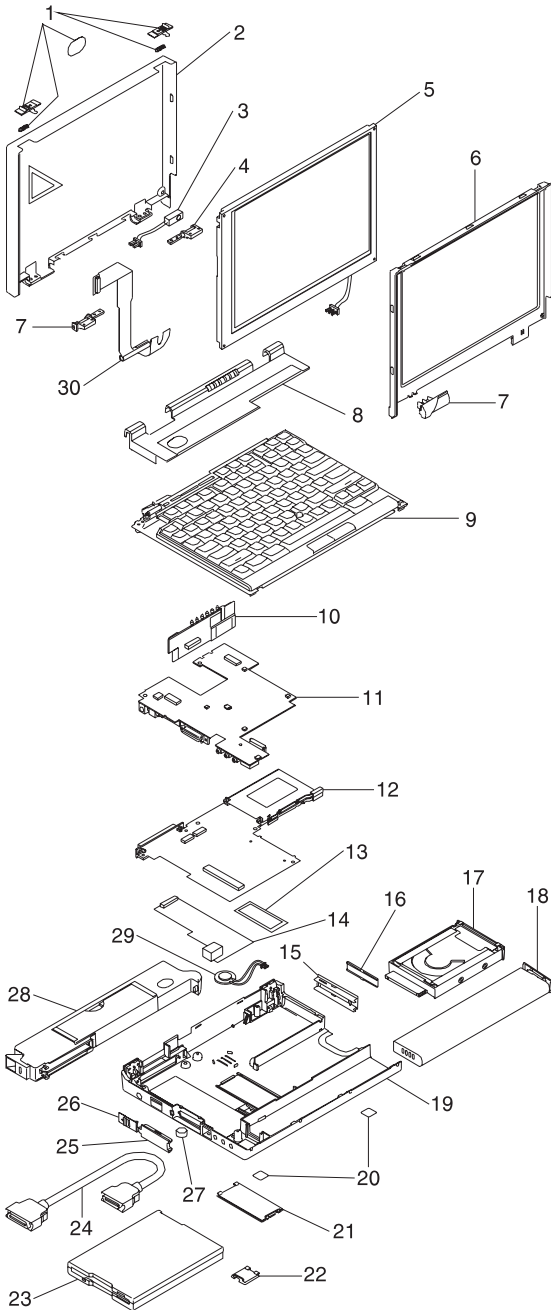

System Unit (ThinkPad 701C/701CS)

Index FRU

1	Latch Kit (Includes logos and spring)	04H8327
2	Display Cover Assembly	04H8326
3	Microphone	04H8328
4	Right Hinge	04H8388
5	Color LCD (ThinkPad 701CS)	04H8333
5	Color LCD (ThinkPad 701C)	04H8331
6	LCD Bezel (ThinkPad 701CS)	04H8325
6	LCD Bezel (ThinkPad 701C)	04H8332
7a	Keyboard Cam	42H1505
7b	Keyboard Hinge	04H8389
8	Keyboard Shelf	04H8336
9	See Keyboard List	
10	Inverter Card/Infrared Transceiver	04H8347
11	Top System Board	04H8343
12	Bottom System Board (25/50MHz)	04H8342
12	Bottom System Board (25/75MHz)	25H4883
13	SO-DIMM (See options list)	
14	Modem	04H8341
15	PCMCIA Cover	04H8346
16	PCMCIA Filler Plug	04H8348
17	360MB Hard Disk Drive	04H6829
17	540MB Hard Disk Drive	04H6830
17	720MB Hard Disk Drive	25H4873
18	Battery Pack NiCD For Worldwide Use (Including Benelux)	04H6898 04H6902
18	Battery Pack NiMH	04H6197
19	Base Assembly	04H8335
20	Base Feet Kit	04H8390
21	SO-DIMM Door	04H8337
22	Standby Battery Door	04H8338
23	Diskette Drive For Japan	10H4056 10H4055
24	Diskette Drive Cable	04H6916
25	Parallel Port Door	04H8340
26	Power Switch Cover	04H8349
27	Standby Battery	04H8345
28	MultiPort II	04H6915
29	Speaker	04H8344
30	LCD Cable	04H8329
	Parallel Port Cable	10H4070
	Screen for Speaker	10H4086
	Speaker Gasket	04H8383
	Docking Door	04H8339

Keyboards

Country

Arabic	04H8319
Belgian	04H8317
Canadian French	04H6918
Danish	04H8316
Dutch	04H8318
French	04H8310
German	04H8311
Greek	04H8322
Hebrew	04H8320
Italian	04H8309
Japanese	04H8323
Latin American	04H6919
Norwegian	04H8314
Portuguese	04H8312
Spanish	04H8308
Swedish/Finnish	04H8313
Swiss/French	04H8315
Swiss/German	04H8373
Turkish	04H8321
U.K. English	04H8307
U.S. English	04H6917

Common/Option Parts List

Miscellaneous Parts

AC Adapter	
For Americas and Japan	04H6903
For Worldwide Use	04H6904
Screw Kit	04H8330
(Includes the following TORX screws)	
Nuts (2)	
M2.5 x 6 mm (9)	
M2.5 x 8.4 mm (4)	
M2.5 x 10 mm (1)	
M1 x 3 mm (4)	
M2.5 x 7.5 mm (4)	
M2.5 x 8 mm (3)	
M2.5 x 5 mm (2)	
M2 x 8 mm (2)	
M2.5 x 16 mm (1)	
TrackPoint III Cover	04H8387

Notes

1. When you replace the AC adapter with a new one, use the one for the country you are in even if the system is from a different country.
2. The warranty for the system unit does not apply to all options.

Options

Memory 70ns, 3.3v, nonparity, self-refresh DIMM

Memory SO-DIMM 4MB	92G7260
Memory SO-DIMM 8MB	92G7262
Memory SO-DIMM 16MB	92G7264
AC Adapter (U.S.)	04H6903
360MB Hard Disk Drive	04H6829
540MB Hard Disk Drive	04H6830
720MB Hard Disk Drive	25H4873
Dock II Adapter Card	04H8353
Dock II Adapter Kit Diskette Drive Cable	25H4879

Tools

Standard Tri-Connector Wrap Plug	72X8546
PCMCIA (PC Test Card)	35G4680
Standard Audio Wrap Cable	66G5180
Standard Screwdriver Kit	95F3598
TORX T1 Screwdriver	10H4156
TORX T6 Screwdriver	10H4157

Power Cords

U.S., Canada	04H6905
Asia Pacific	04H6906
Latin America	04H6907
Europe	04H6908
Japan	04H6909

Warning:

Use the power cord certified for your country.

ThinkPad 355x, 360x, 370C, 750x, 755C, 755Cs

Model 355x - 2619	
Model 360x - 2620	
Model 370C, 750x, 755C, 755Cs - 9545	
Read This First	197
What to Do First	198
General Checkout	200
Memory Checkout	201
System Board and Processor Card Checkout (370C, 750Ce, 755C, 755Cs)	203
Keyboard/Auxiliary Input Device Checkout	203
TrackPoint II checkout	204
Pen and Digitizer Checkout (360P, 360PE, 750P)	205
Audio Card Checkout	205
Diskette Drive Test	206
Power Systems Checkout	207
Power Management Features	213
Symptom-to-FRU Index	216
Numeric Error Codes	217
FRU Codes	220
Beep Symptoms	221
No Beep Symptoms	222
LCD Related Symptoms	223
Keyboard/TrackPoint II Related Symptoms	223
Indicator Related Symptoms	224
Power Related Symptoms	224
Function/Audio Related Symptoms	224
Peripheral Device Related Symptoms	225
Other Symptoms	226
Intermittent Problems	226
Undetermined Problems	227
Related Service Procedures	228
Status Indicators	228
How to Run the Diagnostics	229
Error Log	229
Checking the Installed Devices List	230
Password Combinations	230
How to Run the Low Level Format	230
PC Test Card LED	231
Fn Key Combinations	231
How To Run the Keyboard Diagnostics	231
Product Overview	232
Models 355x, 360x	232
Model 370C	233
Model 750x	233
Models 755C, 755Cs	235
FRU Removals and Replacements	236
Removals Models 355x, 360x	237
1010 Rear Connector Door	237
1015 Foot	237
1020 Battery Pack	238

1030	Diskette Drive	239
1035	Hard Disk Drive	240
1040	Keyboard Unit	241
1050	IC DRAM Card	244
1055	Diskette Drive Bezel	244
1060	Status Indicator	245
1070	LCD Assembly	247
1080	Modem Card (355x)	249
1085	Bezel (360x)	249
1090	Speaker Shield Assembly	253
1095	Interposer Card	253
1100	DC/DC Card	255
1110	Backup Battery	256
1115	Standby Battery	256
1120	System Board Assembly	257
1130	PCMCIA Slot Assembly	259
Removals Models 370C, 750x, 755C, 755Cs		261
2010	Rear Connector Door	261
2015	Foot	261
2020	Battery Pack	262
2030	Diskette Drive	263
2035	Hard Disk Drive	264
2040	Keyboard Unit	265
2050	IC DRAM Card	268
2055	DIMM and DIMM Adapter (755C, 755Cs)	269
2056	Diskette Drive Bezel	271
2060	Status Indicator	272
2070	LCD Assembly	274
2080	Speaker Shield Assembly	277
2085	Audio Card	280
2090	Interposer Card	280
2100	DC/DC Card	281
2110	Backup Battery	282
2105	Standby Battery	282
2120	System Board Assembly	284
2130	PCMCIA Slot Assembly	286
2140	Processor Card (750Ce, 755C, 755Cs)	287
Locations		289
System - Front View (750, 750Cx, 755Cx, 370C, 360x, 355x)		289
System Front View - (750P, 360P, 360PE)		290
System Rear View - All Models		291
System Board (Top View)		292
System Board (Bottom View)		293
Processor Card (370C, 750Ce, 755C, 755Cs)		294
DC/DC Card - Top View		294
Interposer Card - All Models (Front View)		295
Parts Listing		296
Models 350x, 360x		296
Model 370C		300
Model 750x		303
Models 755C and 755Cs		307
Common/Option Parts List		310

Read This First

Service for U. S. and Canada

In the U. S. and Canada, the ThinkPad 370C and ThinkPad 360PE are serviced only through EasyServe.

This hardware maintenance manual covers information about the following IBM ThinkPad models:

- 355, 360, 750 (monochrome)
- 355C, 360C, 360CE, 370C, 750C, 755C (TFT color)
- 750Ce (TFT color, enhanced)
- 355Cs, 360Cs, 360CSE, 750Cs, 755Cs (STN color)
- 360P, 360PE, 750P (pen).

When information affects only a specific model, the model number is shown in parenthesis in the heading or is explained in the text. Before you go to the checkout guide, be sure to read this section.

- **Be extremely careful during write operations such as copying, saving, or formatting.** Drives in the computer that you are servicing might have been rearranged or the drive startup sequence might have been altered. If you select an incorrect drive, data or programs can be written over.
- **Replace FRUs only for the correct model.** When you replace the FRU, make sure the model of the machine and FRU part number are correct by referring to the part list.
- **FRUs should not be replaced because of a single, un-reproducible failure.** Single failures can occur from a variety of reasons that have nothing to do with a hardware defect such as: cosmic radiation, electrostatic discharge, or software errors. FRU replacement should only be considered when a recurring problem exists. If this is suspected, clear the error log and run the test again. Do not replace any FRUs if log errors do not reappear.

The servicer must include the following in the parts exchange form or part return form that is attached to the returned FRU.

- ___ 1. Name and phone number of servicer.
- ___ 2. Date of service.
- ___ 3. Date when part failed.
- ___ 4. Date of purchase.
- ___ 5. Failure symptoms, error codes appearing on display, and beep symptoms.
- ___ 6. Procedure index and page number in which failing FRU was detected.
- ___ 7. Failing FRU name and part number.
- ___ 8. Machine type, model number, and serial number.
- ___ 9. Customer's name and address.

What to Do First

Before checking problems with the computer, determine whether or not the damage applies to the warranty by referring to the following:

Note for Warranty: During the warranty period, the customer may be responsible for repair costs if the damage was caused by misuse, accident, modification, unsuitable physical or operating environment, or improper maintenance by the customer.

The following list provides some common items that are not covered under warranty and some symptoms that could indicate that the system was subjected to stresses beyond normal use.

Warranty Coverage Notes

The following is not covered under warranty:

- LCD panel cracked from being dropped or applying too much force.
- Scratched (cosmetic) parts.
- Cracked or broken plastic parts, broken latches, broken pins or connectors caused by excessive force.
- Damage caused by liquid spilled onto the system.
- Damage caused by improperly inserting a PCMCIA card or installation of an incompatible card.
- Damage due to foreign material in the FDD or FDD bay.
- Damage to the diskette drive caused by pressing the diskette drive cover or inserting diskettes with multiple labels.
- Diskette eject button was bent or damaged.
- Damage to the CD-ROM drive caused by excessive force shocked or dropped.
- Fuse blown by attaching non-supported device.
- Computer or hard disk could not be used because the password was forgotten.

If the following symptoms are present, they could indicate the damage was caused by non-warranted activity:

- Missing parts can be a symptom of unauthorized service or modification.
- HDD spindles can become noisy if subjected to excessive force or is dropped.
- I9990303 errors can be caused by exposure to strong magnetic fields.

How to Use Error Messages: Use the error codes displayed on the screen to diagnose failures. If more than one error code is displayed, begin the diagnosis with the first error code. The cause of the first error code can result in false error codes being displayed. If no error code is displayed, see if the error symptom is listed in the “Symptom-to-FRU Index” on page 216.

How to Diagnose Multiple FRUs: When the adapter or device has more than one FRU, the error code could be caused by either FRU. Before replacing multi-FRUs, try removing or exchanging each FRU, one by one in the designated sequence, to see if the symptoms change.

Passwords: The Passwords are security features that are used to protect the system and the hard disk data from unauthorized access. There are three types of passwords as follows:

- Power-on Password (POP)
- Hard disk Password (HDP)
- Supervisor Password (Privileged Access Password, PAP)

No overriding is provided. Obtaining permission from the password owner to unlock the password is a prerequisite for running diagnostic tests and performing maintenance service.

See “Password Combinations” on page 230 for more information about passwords.

How to Disable the Power-On Password:

Important

This information is not available in this HMM online format. See your IBM Servicer or IBM Authorized Dealer for this procedure.

Reset Pushbutton: The reset pushbutton resets the system regardless of the microcode status and forces power to be powered-off. Use this pushbutton to power-off when power is not completely off or the microcode is in a hung state. See “System Board (Top View)” on page 292 for the location of the pushbutton.

Port Replicator Problems: If you suspect a problem with the Port Replicator, see “Port Replicator Checkout” in the “Common Devices Checkout” section for more information.

General Checkout

Use the following procedure as a guide for computer problems.

Note: The diagnostic tests are intended to test *only* IBM products. Non-IBM products, prototype cards, or modified options can give false errors and invalid system responses.

1. Obtain the failing symptoms in as much detail as possible.
2. Verify the symptoms by attempting to recreate the failure by running the diagnostic test or by repeating the same operation.

Note: To run the diagnostics, refer to “How to Run the Diagnostics” on page 229.

3. Use the following table with the verified symptom to determine which page to go to. Search the symptoms column and find the description that best matches your symptom; then go to the page shown in the “Go to” column.

Symptom	Go to
Power failure. (The power indicator does not go on or stay on.)	“Power Systems Checkout” on page 207.
POST does not complete. No beeps/error code are indicated.	“Symptom-to-FRU Index” on page 216, and then use the No Beep Symptoms table.
POST beeps, but no error codes are displayed.	“Symptom-to-FRU Index” on page 216, and then use the Beep Symptoms table.
POST detected an error and displayed numeric error codes.	“Symptom-to-FRU Index” on page 216, and then use the Numeric Error Codes table.
The diagnostic test detected an error and displayed an FRU code.	“FRU Codes” on page 220.
The configuration is not the same as the installed devices.	“Checking the Installed Devices List” on page 230.
Other symptoms (such as LCD display problems).	“Symptom-to-FRU Index” on page 216, and then use other miscellaneous symptoms tables.
Symptoms cannot be recreated. (Intermittent problems.)	Use the customer reported symptoms and go to “Symptom-to-FRU Index” on page 216.
TV Tuner Problems	See “TV Tuner” on page 477.

Memory Checkout

Depending on the model, the memory size that is available for customer use appears differently. This is **not** a hardware problem. See the following table for the available memory size of each card.

Note: For Models 370C, 755C and 755Cs, one of two types of memory cards can be used, IC DRAM card or DIMM card. If DIMM cards are installed, replace IC DRAM with DIMM in the following.

IC DRAM	750, 750C, 750Cs, 750P	355x, 360x, 370C, 750Ce, 755C, 755Cs
0 MB	3904 KB	3712 KB
2 MB	5952 KB	5760 KB
4 MB	8000 KB	7808 KB
8 MB	12096 KB	11904 KB
16 MB	20288 KB	20096 KB

DIMM	370C, 755C, 755Cs
0 MB	3712 KB
4 MB	7808 KB
8 MB	11904 KB
12 MB	16000 KB
24 MB	28288 KB
16 MB	20096 KB
20 MB	24192 KB
32 MB	36480 KB

Memory errors might stop system operations, show error messages on the screen, or hang the system. The computer detects memory parity errors but does not correct them.

Use the following procedure to isolate memory problems.

Notes on Memory Errors

- For Models 355x, 360x, and 370C, ignore any references to parity errors.
- DIMM Adapter and DIMM card are not supported for 355x and 360x. Remove them (if installed).

1. Installing a non-parity memory card causes memory errors. Before you go to the next procedure, check whether or not the memory card use parity or non-parity. If the non-parity memory card is installed, disable the parity check on Easy-Setup configuration screen.
2. Make sure that the memory card is fully installed into the connector. Loose connection can cause an error.

3. Power-off the computer and remove the IC DRAM card, or DIMM card from its slot (if installed).
4. Press and hold the F1 key; then power-on the computer. Hold the F1 key down until Easy-Setup screen appears.
5. Select **Test** and press enter.
6. Select **Memory** and press enter to run the memory test on base memory. If an error appears, replace the system board.
7. Power-off the computer and reinstall the IC DRAM card; then power-on the computer. Verify the memory size; then test the memory. If an error appears, replace the IC DRAM card.

If memory problems occur intermittently, use the loop option to repeat the test. When the test detects an error, an error log is printed on the printer connected to the parallel port. See "Error Log" on page 229 for more information.

If a parity error is logged in CMOS, POST error code 118 appears when the power is turned on. To clear the log and to test the memory, run the memory diagnostic. If no error is detected by the test, the log is cleared, and error code 118 will not appear the next time the POST is run. If the 118 error code occurs repeatedly, determine and replace the failing memory FRU. FRUs should not be replaced because of a single, un-reproducible failure. Single failures can occur from a variety of reasons that have nothing to do with a hardware defect such as: cosmic radiation, electrostatic discharge, or software errors. FRUs replacement should only be considered when a recurring problems exists. If this is suspected, clear the error log and run the test again. Do not replace any FRUs if log errors do not reappear.

System Programs in Flash Memory: System setup programs and diagnostic tests are stored in Flash memory.

Flash Memory Update: A flash memory update is required for the following conditions:

- New versions of system programs.
- New feature or options are added.

When Updating Flash Memory

Do not power-off the computer, disconnect the Vac power, or remove the battery during the Flash update.

On certain systems, updating Flash memory can reset all customer's configuration settings to the default values.

To update the Flash memory, perform the following steps:

1. Connect the AC Adapter and install the battery pack.

2. Get the appropriate diskette which contains the update.
3. Insert the **System Program Service Diskette** into drive A and power-on the computer.
4. Select **Update system programs** from the menu.

System Board and Processor Card Checkout (370C, 750Ce, 755C, 755Cs)

The processing functions for the Models 370C, 750C, 755Ce, and 755Cs are performed by both the system board and the processor card. Processor problems can be caused by either FRU. However, the processor card generally has a lower probability of failure. When a numeric code calls the system board or the processor card as a FRU, or the processor card is called by a diagnostic test by showing FRU code 11, use the following procedure to isolate the problem.

1. Run the system board test to verify the symptom. This test verifies both the system board and the processor card. If no error is detected, return to "General Checkout" on page 200.
2. If FRU code 10 appears, replace the system board but do not replace the processor card. Transfer the processor card from the old system board to the new system board.
3. If FRU code 11 appears, reseal the processor card.
4. Rerun the test to verify the fix.
5. If FRU code 11 remains, replace the processor card.

If above procedure does not correct the problem, go to "Undetermined Problems" on page 227.

Keyboard/Auxiliary Input Device Checkout

Remove the external keyboard if the internal keyboard is to be tested.

If the internal keyboard does not work or an unexpected character appears, make sure that the three flexible cables extending from the keyboard are correctly seated in the connectors on the interposer card.

If the keyboard cable connection is correct, run the **Keyboard Test** by doing the following:

1. Go to diagnostic menu screen by pressing **Ctrl+A** in Easy-Setup screen.
2. Press **Ctrl+K**; the figure of the keyboard appears on the screen.
3. Check that when each key is pressed, the key position on the keyboard layout on the screen changes to be a black square.

Note: When a Fn key is pressed, the black square briefly appears.

If the tests detect a keyboard problem, do the following one at a time to correct the problem. Do not replace a non-defective FRU.

- Reseat the three cables.
- Replace the keyboard.
- Replace the interposer card.
- Replace the system board.

The following auxiliary input devices are supported for this computer.

- Numeric keypad
- Mouse (PS/2 compatible)
- External keyboard (with keyboard/mouse cable)

If any of the above devices do not work, reseat the cable connector and repeat the failing operation.

If the problem does not occur again, recheck the connector.

If the problem is not corrected, replace the device, and then the system board.

TrackPoint II checkout

If the TrackPoint II will not work, check the configuration in Easy-Setup by selecting **Keyboard** from the **Config** menu. If the configuration of the TrackPoint II disabled, select **TrackPoint** to enable it.

If this does not correct the TrackPoint II problem, continue with the following.

The TrackPoint II does automatic compensations to adjust the pointer sensor. During this process, the pointer moves on the screen automatically for a short time. This self-acting pointer movement can occur when a slight, steady pressure is applied to the TrackPoint II pointer while the computer is powered on or while the system is running, or re-adjustment is required because the temperature has exceeded its normal temperature range. This symptom does not indicate a hardware problem. No service actions are necessary if the pointer movement stops in a short period of time.

If a click button problem or pointing stick problem occurs, do the following:

1. Go to Easy-Setup screen.
2. Select an item with the pointing stick.
3. Press either the left or right click button.
4. Verify that both buttons work correctly.

If either the pointing stick or the click button will not work, do the following actions one at a time to correct the problem. Do not replace a non-defective FRU.

- Reseat the three keyboard cables.
- Replace the keyboard.
- Replace the interposer card.

- Replace the system board.

Pen and Digitizer Checkout (360P, 360PE, 750P)

To check the stylus pen and digitizer, do the following.

1. Press and hold the **F1** key.
2. Power-on the computer to go to Easy-Setup screen.
3. Select **Test** by using the stylus pen.
4. If the test menu appears, the pen and digitizer are operating correctly.

If the menu does not appear, do the following.

- a. Do the "Digitizer Adjustment."
- b. If the problem remains, replace the stylus pen.
- c. If the problem still remains after step 6 in the adjustment, replace the LCD assembly.

Digitizer Adjustment: Adjust the pen-point pressure when:

- The LCD is replaced with a new one.
- The LCD is changed to a pen LCD from a monochrome model.
- The stylus pen or digitizer is not working correctly.

Do the following:

1. Press and hold the **F1** key, then power-on the computer to go to the Easy-Setup menu.
2. Press **Ctrl+P**. The following **Pen** icon appears on the screen.



Pen

3. Open the LCD all the way to 180 degrees. (Do not convert it into the tablet-style notebook.)
4. Select the pen icon by moving the cursor on the icon and clicking it.
5. Without applying any pressure on the screen, hold the stylus pen so it stands on the screen, then press Enter.

Note: The pressure on the screen should only be from the weight of the stylus pen.

6. Restart the system.

Audio Card Checkout

Do the following to run the audio tests.

Note: Refer to "Product Overview" on page 232 to see whether the audio card is standard or not.

1. Power-off the computer.
2. Insert the **ThinkPad 750Ce hardware maintenance diskette** into diskette drive **A** and power-on the computer.

Note: You can use this maintenance diskette for all Models.

3. Select the Audio Diagnostics from the main menu.
4. Select **Tests** from the menu bar and press Enter.
5. Select **All tests** from the pull-down menu and press Enter.

Run options are set to test once and stop on error as defaults. Other options can be selected by the pull-down menu of **Setting-up**.

6. Follow the instructions that appear on the screen to proceed with the tests.
7. If the tests end and no errors are detected, the "All tests passed OK" message appears.
8. If an error is detected, the FRU code and error description message appear. Go to "FRU Codes" on page 220 and replace the FRU.
9. To exit from the test screen, press **Esc**.

Diskette Drive Test

Do the following to isolate the problem to a controller, drive, or diskette. A scratch, write enabled, non-defective 2HD diskette is required.

Warning: Make sure that the diskette does not have more than one label attached to it. Multiple labels can cause damage to the drive or can cause the drive to fail.

1. Do the following to select the test device:
 - a. Select the advanced diagnostic mode and select **Tool**;
 - b. Select the icon **FDD-1** or **FDD-2** and press the space key.

A ✓ mark appears next to the selected icon.

Insert the **blank** diskette when instructed.

2. Run the diskette drive test.
3. If the controller test detects an error, FRU code 10 appears. Replace the system board.
4. If the controller test runs without errors, the drive read/write tests start automatically.
5. If the drive test detects an error, FRU code 50 for FDD-1 or 51 for FDD-2 appears. If the diskette itself is known to be good, replace the drive.
6. If the drive is attached through a Port Replicator as FDD-1 or FDD-2 and the test detects errors, move the drive to the computer's diskette drive connector directly, and test it again as FDD-1.

If no errors occur at the FDD-1 position, the drive is not defective. Go to "Port Replicator Checkout" in "Common Devices Checkout" section to isolate the replicator problem.

7. If the drive is attached through an Expansion Unit, go to the service manual of the Expansion Unit to isolate the problem.

8. If the drive is attached through a Diskette Drive Attachment Unit, replace the unit.

Power Systems Checkout

To verify the symptom of the problem, power-on the computer using each of the power sources available as follows.

1. Remove the battery pack, diskette drive, and hard disk drive.
2. Connect the AC Adapter and check that power is supplied.
3. Install the diskette drive, or hard disk drive one at a time and check that power is supplied from each power source.
4. Disconnect the AC Adapter, remove the hard disk and diskette drive, and install the charged battery pack; then check that power is supplied by battery pack.

If you suspect a power problem, see the appropriate power supply check listed below.

- "Checking the AC Adapter." on page 208.
- "Checking Operational Charging" on page 208.
- "Checking the Battery Pack" on page 208.
- "Checking the Car-Battery Adapter" on page 210.
- "Checking the Quick Charger" on page 211.
- "Checking the Backup Battery" on page 211.
- "Checking the Standby Battery" on page 212.
- "Port Replicator Power Overload" on page 215.

Checking the AC Adapter: You are here because the computer fails only when the AC Adapter is used.

- If the power problem occurs only when the port replicator is used, replace the replicator.
- If the power-on indicator does not turn on, check the power cord of the AC Adapter for correct continuity and installation.
- If the operational charge does not work, go to "Checking Operational Charging" on page 208.

Note: There are two types of adapters. The procedure for checking both types is the same.

1. Unplug the AC Adapter cable from the computer and measure the output voltage at the plug of the AC Adapter cable. See the following figure.

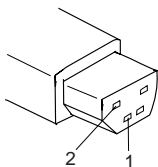

Pin	Voltage (V dc)
1	+19.0 to +21.0
2	Ground

- If the voltage is correct, replace the system board. If the problem is not corrected, go to “Undetermined Problems” on page 227.
 - If the voltage is not correct, go to the next step.
2. Unplug the AC Adapter cable from the ac power outlet and wait five minutes or longer to allow the over voltage protection circuit to be fully discharged and initialized.
 3. Plug the AC Adapter cable into the ac power outlet.
 4. Measure the output voltage of the AC Adapter.
 5. If the voltage is still not correct, replace the AC Adapter.

Note: An audible noise from the AC Adapter does not always indicate a defective adapter.

Checking Operational Charging: To check operational charging, use a discharged battery pack or a battery pack that shows a yellow or orange battery status indicator when it installed in the computer.

Perform operational charging. If the battery status indicator turns orange and the battery charging indicator turns green within two minutes, replace the AC Adapter.

Checking the Battery Pack: Battery charging will not start until the Fuel-Gauge shows that less than 90% of the total power remains; with this condition the battery pack will charge to 100% of its capacity. This protects the battery pack from being over-charged or having a shortened life.

Notes:

- a. Models 355x and 360x battery pack does not contain a microprocessor. In the following, ignore any reference to the storage switch.
 - b. Before you perform the following procedure, check the following:
 - The correct battery pack is used for the model.
 - The storage switch set to on (|).
1. Power-off the computer.
 2. Remove the battery pack and measure the voltage between battery terminals 1 (+) and 4 (-). See the following figure.

Note: The following figure shows the battery for the Model 370C, 750x, 755C, and 755Cs. The battery for Models 355x and 360x, do not have the storage switch, but the battery terminals are the same.

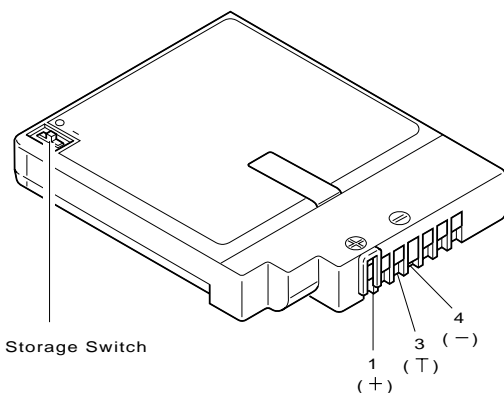

Terminal	Voltage (V dc) / Signal
1	+8.0 to +16.0
2	Send
3	Thermal
4	Ground (-)
5	R1
6	Select
7	R2

Note: Signal lines, not used in these steps, are used for communication between the system and the battery. The storage switch is used to control the power to the internal microprocessor of the battery. The storage switch should be set to off (0) only when the battery is going to be kept in storage for more than two months.

- If the voltage is less than +8.0 V dc, the battery pack has been discharged or is defective. Recharge the battery. If the recharging does not work, go to Step 5 to check the charging circuit.

If the voltage is still less than +8.0 V dc after the recharging, replace the battery.

- If the voltage is more than +8.0 V dc, measure the resistance between battery terminals 3 and 4. The resistance must be 4 to 30 kilohms.

If the resistance is not correct, replace the battery pack.

If the resistance is correct, replace the DC/DC card.

- To check the charging circuit, do the following. Plug in the AC Adapter with the battery pack removed, then power-on the computer.
- Measure the charging voltage between DC/DC terminals 1 (+) and 4 (-).

- If the voltage is less than +9.0 V dc, replace the DC/DC card. If the voltage is more than +9.0 V dc, the charging circuit is working correctly, replace the battery pack.

Checking the Car-Battery Adapter: There are two types of adapters but the checkout procedure is the same for both of them.

- Unplug the Car-Battery Adapter cable from the computer.
- Plug the Car-Battery Adapter into the cigarette lighter socket.

Note: If the adapter is already plugged in, reseal it.

- Measure the output voltage of the Car-Battery Adapter cable. See the following figure.

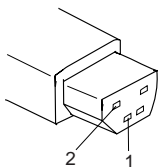

Pin	Voltage (V dc)
1	+19.0 to +21.0
2	Ground

- If the voltage is correct and the power-on indicator on the Car-Battery Adapter is on all the time, the Car-Battery is working correctly. Replace the system board.

If the problem is not resolved when the system board is replaced, go to “Undetermined Problems” on page 227.

- If the voltage is outside the normal voltage range, do one of the following:
 - Try the above test procedures in a different car, if one is available.
 - Replace the Car-Battery Adapter if the computer works correctly with the AC Adapter.

Notes:

- If the output voltage from the cigarette lighter socket of the car is less than 10.5 V dc, the power-on indicator on the Car-Battery Adapter blinks and a continuous noise can be heard. The condition of the car battery should be checked by appropriate service personal.
- The Car-Battery Adapter does not support operational charging.

Checking the Quick Charger: There are two types of chargers, but checkout procedures are the same for both of them.

1. Ensure that the battery pack is operating correctly. (See "Checking the Battery Pack" on page 208.)
2. Connect the power cord to the quick charger and the other end to an ac power outlet. Ensure that the power-on indicator is on.
 - If the power-on indicator does not turn on, check the power cord for correct continuity and installation.
 - If the problem is not corrected, replace the quick charger or the power cord.
3. Install the battery pack into the quick charger.
 - If the charging indicator does not start blinking, replace the quick charger.

Checking the Backup Battery

1. Power-off the computer and unplug the AC Adapter from the computer.
2. Open the keyboard, and remove the battery pack and the diskette drive.
3. Remove the backup battery from the system board.
4. Measure the voltage of the backup battery. See the following figure.

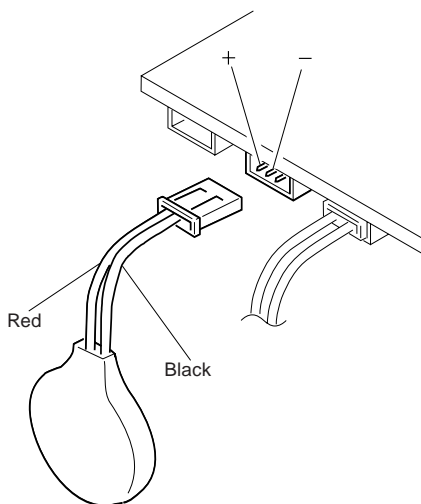

Wire	Voltage (V dc)
Red	+2.5 to +3.7
Black	Ground

- If the voltage is correct, replace the system board.
- If the voltage is not correct, the backup battery has been discharged. Replace the backup battery.

- If the backup battery discharges quickly after replacement, replace the system board.

Checking the Standby Battery

1. Power-off the computer and unplug the AC Adapter from the computer.
2. Open the keyboard, and remove the battery pack and the diskette drive.
3. Remove the standby battery.
4. Measure the voltage of the standby battery.
 - If the voltage between red and black is 3.5 V dc or greater, the voltage is correct. Go to Step 10 on page 213 to verify standby battery operation.
 - If the voltage is less than 3.5 V dc, go to the next step.
5. Plug the AC Adapter into the computer and power-on the computer.
6. Measure the output voltage at the connector on the system board.

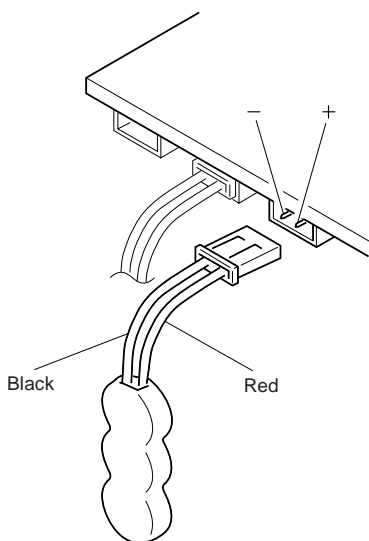

Pin	Voltage (V dc)
+	+4.0
-	Ground

- If the voltage is less than +4.0 V dc, replace the DC/DC card. If the voltage is still low, replace the system board.
 - If the voltage is more than +4.0 V dc, power-off the computer, replace the standby battery, and go to the next step.
7. Ensure that the AC Adapter is plugged into the computer; then power-on the computer.

8. Charging of the standby battery starts. A depleted battery needs approximately 30 minutes to be recharged to the operational voltage of +3.5 V dc.
9. Unplug the AC Adapter.
10. Verify the standby battery function by removing and installing the battery pack during suspend mode.

Note: Removing and installing the battery pack during suspend mode should be done within one minute. The resume operation must start. If the resume operation does not work, switching of power from the battery pack to standby battery will not be correct. Replace the DC/DC card.

If replacing the DC/DC card does not resolve the problem, replace the system board.

Power Management Features

Three power management modes are provided by the computer to save power consumption and prolong battery power.

Standby Mode: When in standby mode the following occurs:

- The LCD backlight turns off.
- The hard disk motor stops.
- The CPU clock is set to the lowest speed.

Events that cause entering of standby mode:

- Standby requested by the Fn key. (Fn+F3)
- No activity under **auto-standby** enabled by the feature utility.

Events that cause exiting or resuming of standby mode:

- (Resume) Any key operation.

Suspend Mode: When in suspend mode, the following, in addition to the four actions of standby mode, occur:

- The LCD power is powered-off.
- The hard disk is powered-off.
- The CPU is stopped.

In the ThinkPad Features Program, the computer can be set to "Will not suspend even if LCD is closed."

When the computer is powered with ac power and is used with one of the following IBM PC cards, the computer enters *standby mode*; the PC card and application program remain active.

- 3270 Emulation Credit Card Adapter
- 5250 Emulation Credit Card Adapter
- Token-Ring 16/4 Credit Card Adapter
- Credit Card Adapter for Ethernet

In the following condition, the computer cannot enter the suspend mode.

- While the communication link is running.
- When a serial mouse or other pointing device is selected in the **Config** menu of Easy-Setup.

Events that cause entering of suspend mode:

- Suspend mode is requested by the Fn key (Fn+F4).
- The LCD is closed.
- The keyboard is opened.
- The specified time has elapsed from the last operation with the keyboard, mouse, hard disk drive, parallel connector, diskette drive, or the AC Adapter is plugged in. The time is specified by **Suspend Timer** in the ThinkPad Features program.
- The battery condition is low. The battery power indicator blinks (orange).
- *The PS2 OFF* command is set in the ThinkPad Features program.

Events that cause exiting or resuming of suspend mode:

- (Resume) The LCD is opened.
- (Resume) The keyboard is closed.
- (Resume) Real time clock alarm signaled.
- (Resume) Ring indicator (RI) signaled by serial or PCMCIA device.
- (Resume) The Fn key is pressed.
- (Exit) Timer conditions are satisfied to enter hibernation mode.

Hibernation Mode: When in hibernation mode, the following occurs:

- The system status, RAM, VRAM, and setup data are stored on the hard disk.
- The system is powered-off.

The computer cannot enter hibernation mode when:

- A serial mouse or other pointing device is selected in the **Config** menu.
- The computer is powered with ac power and one of the following IBM PC cards is used.
 - PCMCIA Data/FAX Modem
 - High Speed PCMCIA Data/FAX Modem
 - 3270 Emulation Credit Card Adapter
 - 5250 Emulation Credit Card Adapter
 - Token-Ring 16/4 Credit Card Adapter
 - Credit Card Adapter for Ethernet

Events that cause entering of hibernation mode:

- The hibernation mode is requested by the Fn key (Fn+F12).
- Timer conditions are satisfied in suspend mode.
- Critical low battery condition.

Event that causes exiting of hibernation mode.

- The power-on switch is operated.

When power is turned on, the hibernation history of the boot record on the hard disk is recognized and system status is restored from the hard disk to resume operation.

Port Replicator Power Overload: If power shut downs occur intermittently when using PCMCIA-2 devices via a port replicator, suspect an over-current problem. Some PCMCIA devices use more power; if the maximum usage of each device occurs simultaneously, the total current will exceed the limit, thereby causing a power shut down. Isolate this problem by removing one of the devices, and use the computer under the same condition to see whether a power shut down occurs. Do this procedure for all devices, then determine the cause. Use of the larger AC Adapter (50W, optional) is recommended, if one is not yet in use.

Symptom-to-FRU Index

The Symptom-to-FRU Index lists the symptoms and errors and the possible causes. The most likely cause is listed first.

Note: Perform the FRU replacement or actions in the sequence shown in the “FRU/Action” columns. If a FRU did not solve the problem, put the original part back in the computer.

This index can also be used to help you decide which FRUs to have available when servicing a computer.

Numeric error codes show the errors detected in POST or system operation. In the following error codes, **X** can be any number.

If no codes are available, use narrative symptoms.

If the symptom is not listed, go to “Undetermined Problems” on page 227.

Notes:

- For IBM devices not supported by the diagnostic codes in this manual, see the manual for that device.
- If the LCD is replaced with a new one, see “Digitizer Adjustment” on page 205 to adjust the pen-point pressure.

Numeric Error Codes

Symptom/Error	FRU/Action
10X	1. System Board
110	<ol style="list-style-type: none"> 1. Go to “Memory Checkout” on page 201. 2. IC DRAM Card or DIMM Card 3. System Board
111	<ol style="list-style-type: none"> 1. Go to “Memory Checkout” on page 201. 2. Expansion Unit/Port Replicator 3. System Board
118 (Memory parity error was logged in CMOS.) (Go to “Memory Checkout” on page 201.)	1. Run memory diagnostics to clear the error log.
158 (HDP was not set even though the supervisor password is set.)	1. Set a HDP.
159 (HDP is not set the same as the supervisor password.)	1. Set a correct HDP.
161	<ol style="list-style-type: none"> 1. Go to “Checking the Backup Battery” on page 211. 2. Backup Battery 3. System Board
163 (Time and Date was not set.)	<ol style="list-style-type: none"> 1. Set Time and Date. 2. System Board
173 (Configuration data were lost.)	<ol style="list-style-type: none"> 1. Select OK in the error screen; then set time and date 2. Backup Battery 3. System Board
174 (Perform “Checking the Installed Devices List” on page 230 before changing any FRUs.)	<ol style="list-style-type: none"> 1. Check Device Configuration. 2. System Board 3. Diskette Drive Assembly 4. Hard Disk Drive Assembly
175, 177, 178	1. System Board
183 (Incorrect password entered at the supervisor password prompt.)	1. Have the user examine the password.
184 (POP check sum error.)	1. Reset the POP in Easy-Setup.

Symptom/Error	FRU/Action
185 (The startup sequence is not valid. Suspect that power was off when the startup sequence was being updated.)	1. Reset the startup sequence in Easy-Setup.
186	1. System Board
188	1. Set the system identification using the ThinkPad 750Ce hardware maintenance diskette. Note: You can use this maintenance diskette for all Models.
190 (Depleted battery pack was installed when the power was on.)	1. Go to “Checking the Battery Pack” on page 208.
191XX	1. System Board 2. Processor card (370C, 750Ce, 755C, and 755Cs)
195 (The configuration read from the hibernation area does not match the actual configuration.)	1. Check if the configuration was changed. For example, check if the disk drive is from another computer.
196 (Read error occurred in the hibernation area of the HDD.)	1. Run the hard disk drive test. 2. Hard Disk Drive
197 (The computer memory size is not equal to the hibernation area size on the HDD.)	1. Have the user disable then enable hibernation mode.
199XX	1. System Board
1XX	1. System Board
2XX	1. Go to “Memory Checkout” on page 201. 2. IC DRAM Card, DIMM, or DIMM Adapter 3. System Board

Symptom/Error	FRU/Action
301, 303, 304, 305, 3XX	<ol style="list-style-type: none"> 1. Go to “Keyboard/Auxiliary Input Device Checkout” on page 203. 2. Keyboard 3. Interposer Card 4. External Numeric Keypad 5. External Keyboard 6. Keyboard/Mouse Cable 7. System Board
601, 6XX	<ol style="list-style-type: none"> 1. Go to “Diskette Drive Test” on page 206. 2. Diskette Drive Assembly 3. Diskette 4. System Board
602 (Diskette read error.)	<ol style="list-style-type: none"> 1. Go to “Diskette Drive Test” on page 206. 2. Diskette 3. Diskette Drive Assembly
604 (Non-acceptable ID was read from the diskette drive.)	<ol style="list-style-type: none"> 1. Go to “Diskette Drive Test” on page 206. 2. Diskette Drive Assembly 3. System Board
11XX	<ol style="list-style-type: none"> 1. Serial Device (First) 2. Communication Cable 3. System Board
12XX	<ol style="list-style-type: none"> 1. Serial Device (Second) 2. Communication Cable 3. System Board
17XX	<ol style="list-style-type: none"> 1. Hard Disk Drive 2. System Board
24XX	<ol style="list-style-type: none"> 1. System Board
4101	<ol style="list-style-type: none"> 1. Reseat the LCD connector (Pen, see “2070 LCD Assembly” on page 274). 2. LCD Assembly 3. System Board
808X	<ol style="list-style-type: none"> 1. PCMCIA Slot Assembly 2. PCMCIA Device 3. System Board
860X (Pointing device error when TrackPoint II is disabled.)	<ol style="list-style-type: none"> 1. External Mouse 2. External Keyboard 3. System Board

Symptom/Error	FRU/Action
861X (Pointing device error when TrackPoint II is enabled.)	<ol style="list-style-type: none"> Reseat the keyboard Track Point II cable at the interposer card. 355x, 360x See "1040 Keyboard Unit" on page 241. 370C, 750x, 755C, 755Cs See "2040 Keyboard Unit" on page 265. Keyboard External Mouse System Board
I9990301 I9990302 I9990305	<ol style="list-style-type: none"> Reseat the boot device. Check the startup sequence for the correct boot device. Check that operating system has no failure, or is installed correctly.
I9990303	<ol style="list-style-type: none"> System Board
Other codes not listed above	<ol style="list-style-type: none"> Go to "Undetermined Problems" on page 227.

FRU Codes

If an error is detected by the diagnostic tests, a *four-digit* FRU code is displayed. The FRU code indicates two suspected FRUs. Replace the FRU that is indicated by the *two leftmost digits* first, then replace the FRU indicated by the *two rightmost digits*. No FRU is assigned to code 00. If only one FRU is suspected, the other FRU code is filled with zeros. See the referenced page before replacing the FRU.

FRU Code	FRU/Action
10	System Board
11	Processor Card (370C, 750Ce, 755C, and 755Cs)
15	Audio Card
20	Memory (See "Memory Checkout" on page 201.)
30	Reserved
32	External Keyboard
33	External Mouse
40	LCD Assembly (See "Digitizer Adjustment" on page 205 and important note for "LCD Related Symptoms" on page 223.)

FRU Code	FRU/Action
45	External CRT
50	<ol style="list-style-type: none"> 1. Reseat the Drive (FDD-1) 2. Diskette Drive (FDD-1)
51	<ol style="list-style-type: none"> 1. Reseat the Drive (FDD-2) 2. Diskette Drive (FDD-2)
60	<ol style="list-style-type: none"> 1. Reseat the Hard Disk Drive (HDD-1) 2. Hard Disk Drive (HDD-1)
61	<ol style="list-style-type: none"> 1. Reseat the Hard Disk Drive (HDD-2) 2. Hard Disk Drive (HDD-2)
70	PCMCIA-2 (Replicator)
80	Cellular Modem (370C, 750Ce, 755C, and 755Cs)
81	Internal Modem Card
90	Reserved

Note: The device ID and error codes are used to indicate the detail portion of the FRU which caused the error. If replacing a FRU does not correct a problem, see the Device ID or error code from the previous failure. If they have changed, the cause might be because the new FRU is defective or that the FRU was incorrectly installed.

If the problem remains after replacement of the FRUs, go to “Undetermined Problems” on page 227.

Beep Symptoms

Symptom/Error	FRU/Action
Continuous beeps.	System Board
One beep and a blank, unreadable, or flashing LCD.	<ol style="list-style-type: none"> 1. Reseat all LCD connectors. 2. LCD Assembly 3. System Board 4. DC/DC Card
One beep, and the message “Unable to access boot source.”	<ol style="list-style-type: none"> 1. Boot device 2. System Board
One long, two short beeps and a blank or unreadable LCD.	<ol style="list-style-type: none"> 1. System Board 2. LCD Assembly
One long beep followed by four short beeps each time the power switch is operated. (System cannot power-on due to low battery voltage.)	Connect the AC Adapter or install a fully-charged battery.
One beep every second. (System is shutting down due to low battery voltage.)	Connect the AC Adapter or install a fully-charged battery (allows system to complete shutdown before changing the battery).

Symptom/Error	FRU/Action
Two short beeps with error codes.	POST error. See “Numeric Error Codes” on page 217.
Two short beeps with blank screen.	System Board

No Beep Symptoms

Symptom/Error	FRU/Action
No beep, power-on indicator not on, and a blank LCD during POST.	<ol style="list-style-type: none"> 1. Go to “Power Systems Checkout” on page 207. 2. System Board 3. DC/DC Card 4. Power sources
No beep, power-on indicator on, and a blank LCD during POST.	<ol style="list-style-type: none"> 1. System Board 2. DC/DC Card 3. Processor Card (370C, 750Ce, 755C, 755Cs)
No beep, power-on indicator on, and a blinking cursor only during POST.	<ol style="list-style-type: none"> 1. System Board 2. Processor Card (370C, 750Ce, 755C, and 755Cs) 3. DC/DC Card
No beep during POST but system runs correctly.	<ol style="list-style-type: none"> 1. Turn the volume up and check the speaker 2. Speaker 3. Audio Card 4. DC/DC Card

LCD Related Symptoms

The TFT LCD of the notebook computers contain over 921 000 thin film transistors (TFTs). A small number of missing, discolored or lighted dots (on all the time) is characteristic of TFT LCD technology. Excessive pixel problems can cause viewing concerns. The LCD should be replaced if the number of missing or discolored, or lighted dots in any colored background is 21 or more.

Symptom/Error	FRU/Action
No beep, power-on indicator on, and a blank LCD during POST.	<ol style="list-style-type: none"> 1. System Board 2. DC/DC Card 3. Processor Card (370C, 750Ce, 755C, and 755Cs)
<ul style="list-style-type: none"> • LCD backlight not working, or • LCD too dark, or • LCD brightness cannot be adjusted, or • LCD contrast cannot be adjusted. 	<ol style="list-style-type: none"> 1. Reseat the LCD connectors. 2. LCD Assembly 3. Interposer Card 4. DC/DC Card
<ul style="list-style-type: none"> • LCD screen unreadable, or • Characters missing pels, or • Screen abnormal, or • Wrong color displayed. 	<ol style="list-style-type: none"> 1. See the preceding important note. 2. Reseat the all LCD connectors 3. LCD Assembly 4. System Board 5. Interposer Card
LCD has extra horizontal or vertical lines displayed.	<ol style="list-style-type: none"> 1. LCD Assembly

Keyboard/TrackPoint II Related Symptoms

Symptom/Error	FRU/Action
Keyboard (one or more keys) does not work.	<ol style="list-style-type: none"> 1. Reseat the three keyboard cables. 2. Keyboard 3. Interposer Card 4. System Board
TrackPoint II does not work.	<ol style="list-style-type: none"> 1. Go to “TrackPoint II checkout” on page 204. 2. Keyboard 3. Interposer Card 4. System Board
Pointer moves automatically or does not work correctly.	<ol style="list-style-type: none"> 1. See “TrackPoint II checkout” on page 204.

Indicator Related Symptoms

Symptom/Error	FRU/Action
Indicator incorrectly remains off or on, but system runs correctly.	<ol style="list-style-type: none">1. Reseat the status indicator cable.2. Status Indicator3. Interposer Card4. System Board
Battery power status indicator blinks from green, yellow, to orange.	<ol style="list-style-type: none">1. Check that a correct battery is installed.2. Set the battery storage switch to ON.3. Battery Pack4. DC/DC Card5. System Board

Power Related Symptoms

Symptom/Error	FRU/Action
Power shut down during operation.	<ol style="list-style-type: none">1. Go to “Power Systems Checkout” on page 207.2. Battery Pack3. Remove the battery pack and let it cool for two hours.4. DC/DC Card5. Power sources
The system will not power-off. (See “Reset Pushbutton” on page 199.)	<ol style="list-style-type: none">1. Press the Reset pushbutton.2. System Board

Function/Audio Related Symptoms

Symptom/Error	FRU/Action
The system will not suspend or resume by opening or closing the keyboard.	<ol style="list-style-type: none">1. Go to “Suspend Mode” on page 213 and check that the computer can enter suspend mode.2. Go to Easy-Setup screen and press Fn+4. If the computer enters suspend mode, suspect that the application program is defective.3. DC/DC Card4. Interposer Card5. System Board

Symptom/Error	FRU/Action
The system will not suspend or resume by opening or closing the LCD.	<ol style="list-style-type: none"> 1. Go to “Suspend Mode” on page 213 and that check that the computer can enter suspend mode. 2. Go to Easy-Setup screen and press Fn+4. If the computer enter suspend mode, suspect that the application program is defective. 3. Interposer Card 4. DC/DC Card 5. System Board
Battery Fuel-Gauge does not go higher than 90%.	<ol style="list-style-type: none"> 1. Go to “Checking the Battery Pack” on page 208 and see the note.
Audio problems.	<ol style="list-style-type: none"> 1. Run the Audio Test. 2. Audio Card
Memory count (size) appears differently from actual size.	<ol style="list-style-type: none"> 1. Go to “Memory Checkout” on page 201.
System configuration does not match the installed devices.	<ol style="list-style-type: none"> 1. Go to “Checking the Installed Devices List” on page 230.
System hangs intermittently.	<ol style="list-style-type: none"> 1. Go to “Intermittent Problems” on page 226.

Peripheral Device Related Symptoms

Symptom/Error	FRU/Action
External display does not work correctly.	<ol style="list-style-type: none"> 1. See “External Display Self-Test” in “Common Devices Checkout” section.
Printer problems.	<ol style="list-style-type: none"> 1. Run Printer Self-test. 2. System Board 3. Parallel Port Device 4. Cable
Serial or parallel port device problems.	<ol style="list-style-type: none"> 1. Device 2. Device Cable 3. System Board

Other Symptoms

Symptom/Error	FRU/Action
Stylus pen or digitizer does not work correctly.	1. Go to “Pen and Digitizer Checkout (360P, 360PE, 750P)” on page 205.
Errors occur only when Port Replicator is used.	1. See “Port Replicator Checkout” in “Common Devices Checkout” section.
PCMCIA slot pin is damaged.	1. PCMCIA Slots Assembly

Note: If you cannot find a symptom or error in this list and the problem remains, see “Undetermined Problems” on page 227.

Intermittent Problems

Intermittent system hang problems can be caused by a variety of reasons that have nothing to do with a hardware defect such as: cosmic radiation, electrostatic discharge, or software errors. FRUs replacement should only be considered when a recurring problems exists.

When analyzing the intermittent problem, do the following:

1. Run the advanced diagnostic test for the system board in loop mode at least 10 times.
2. If no error is detected, do **not** replace any FRUs.
3. If any error is detected, replace the FRU shown by the FRU code. Rerun the test to verify that no more errors exist.

Undetermined Problems

You are here because the diagnostic tests did not identify which adapter or device failed, installed devices are incorrect, a short circuit is suspected, or the system is inoperative. Follow the procedures below to isolate the failing FRU (do not isolate non-defective FRUs).

Verify that all attached devices are supported by the computers.

Verify that the power supply being used at the time of the failure is operating correctly. (See "Power Systems Checkout" on page 207.)

1. Power-off the computer.
2. Check the cables, wires, and connectors for short circuits and open circuits. Visually check them for damage. If any problems are found, replace the FRU.
3. Remove or disconnect all of the following devices.
 - a. Non-IBM devices
 - b. Devices attached to the expansion bus connector
 - c. Printer, mouse, and other external devices
 - d. Battery pack
 - e. Hard disk drive
 - f. Diskette drive or the device attached to the diskette drive connector
 - g. IC DRAM card or DIMM card
 - h. PC cards

Note: Remember that removing the hard disk drive, an IC DRAM card, or any adapter or device, might cause configuration errors. Ignore error code 174.

4. Power-on the computer.
5. Determine if the problem has changed.
6. If the problem does not occur again, reconnect the removed devices one at a time until you find the failing FRU.
7. If the problem remains, replace the following FRUs one at a time. Do not replace a non-defective FRU.
 - DC/DC card
 - Audio card
 - Interposer card
 - LCD assembly
 - System board
 - Processor card (370C, 750Ce, 755C, and 755Cs)









Related Service Procedures



This section provides information about the following:

- “Status Indicators”
- “How to Run the Diagnostics” on page 229
- “Error Log” on page 229
- “Checking the Installed Devices List” on page 230
- “Password Combinations” on page 230
- “How to Run the Low Level Format” on page 230
- “PC Test Card LED” on page 231
- “Fn Key Combinations” on page 231
- “How To Run the Keyboard Diagnostics” on page 231

Status Indicators

The system status indicators show the current computer status in different colors (green, yellow, and orange).

Symbol	Color	Meaning
	Blinking green	Speaker sounds (Does not sound for Models 355, 355Cs, 360, 360Cs, and 370C.)
	Green	Battery fully charged
	Yellow	Battery usable
	Orange	Battery low
	Blinking orange	Battery almost depleted
	Blinking green, yellow, and orange	Battery storage switch is set off
	Green	Battery charging
	Orange	PC card in-use
	Orange	Diskette drive in-use
	Orange	Hard disk drive in-use
	Green	Keys in Num Lock mode
	Green	Keys in Caps Lock mode
	Green	Keys in Scroll Lock mode

Symbol	Color	Meaning
	Green	Computer in suspend mode
	Blinking green	Computer resuming normal mode
	Green	Computer powered on

How to Run the Diagnostics

Use either the TrackPoint II or the cursor move keys to interact with the tests. The Enter key works the same as selecting the OK icon to reply OK.

1. Press and hold the F1 key; then power-on the computer. Hold the F1 key down until Easy-setup screen appears.
 2. Select **Test** and press Enter.
 3. Select a device and press Enter to run the test.
 4. The test progress screen appears.
 5. **OK** appears when the test ends without any errors.
 6. Start the **Advanced Diagnostic test** by pressing **Ctrl+A** on the basic diagnostic menu screen.
 7. Select **Tool** to install the tools.
 8. Select a device, press the **space** key, and install the tool. Multiple devices can be selected by repeating this step.
- A √ mark appears for the selected device.
9. Select **OK** and press Enter if the selection is OK.
 10. Select a device and press Enter to start the tests.
 11. Select **Test All** to test all devices.
 12. Select **Loop Test** to loop tests.

A loop option menu appears in which a device loop or all loop can be selected. Select a device and press the **space** key to select a device. Repeat this step to select multiple devices. Press Enter to start the diagnostic loop. If no device is selected, all device tests are looped.

13. To exit the loop, keep pressing **Ctrl+Pause** until the test exits. A beep sounds (750Ce, 755C, 755Cs) to notify that the exit interrupt is sensed by the test program.

Error Log

Diagnostic errors are printed on the printer that is attached to the parallel port when the error is detected. The error is also logged in the system memory.

Do the following procedure to display the errors.

1. End the test, if it is running.
2. Press **Ctrl+A** to select the advanced diagnostic mode.
3. Press **Ctrl+E**.
4. The error log appears.

5. To exit the screen, select the cancel icon or press Esc.

The error log is not saved when system power is powered-off.

Checking the Installed Devices List

If a device is installed but the icon appears in a gray shade rather than a dark shade on the basic diagnostics screen, the device is defective. Reseat the device connectors. If the symptom remains, replace the device or the system board. If needed, adjust the contrast control to clearly distinguish the shades of the icon.

If a device that is not installed appears in a dark shade, for example, FDD-2 appears in a dark shade when *NO* second FDD is installed, do the following.

1. Replace the **first** device, such as a FDD-1, HDD-1, or PCMCIA-1.
2. If the problem remains, replace the system board.

PCMCIA-1, Parallel, and Serial icons are always displayed in dark shade, because the icons represent subsystems of the system board and not attachment of the devices.

The HDD-1, FDD-1, or PCMCIA-1 represents the **first** drive in the system configuration, respectively. Similarly, the HDD-2, FDD-2, or PCMCIA-2 represents the **second** drive, usually attached through a port replicator or an expansion unit.

Password Combinations

The password relationship is:

- ***When POP is the same as HDP***
The POP prompt appears, but the HDP prompt does not appear.
- ***When POP is not the same as HDP***
Both POP and HDP prompts appear.
- ***PAP and HDP***
When PAP is used, the HDP is enabled automatically, but no HDP prompt appears. The HDP is set the same as PAP.

How to Run the Low Level Format

Do the following to format the hard disk. **Warning:** Make sure the drive address to be formatted is correct. This procedure will erase all information on the disk.

1. Power-off the computer.
2. Insert the **ThinkPad 750Ce hardware maintenance diskette** into diskette drive **A** and power-on the computer.

Note: You can use this maintenance diskette for all Models.

3. Select **Format the hard disk** from the main menu.
4. Select the drive from the menu.
5. Follow the instructions on the screen.

PC Test Card LED

The green LED on the PC test card turns on when the PCMCIA test is running. If the LED does not turn on, check that the card is installed correctly by reseating the card. If it still does not turn on after it is reseated, try using another slot for the test. If the LED still does not turn on and the test fails, replace the FRU shown in the diagnostic error code.

Fn Key Combinations

The following table shows the **Fn** key and function key combinations and their corresponding functions.

The Fn key works independently from the operating system. The operating system obtains the status through the system management interface to control the system.

Fn +	Description
F1	Reserved
F2	Fuel-gauge display ON/OFF
F3	Standby mode invocation
F4	Suspend mode invocation
F5	Audio volume Down
F6	Audio volume UP
F7	LCD/CRT display switching
F8	LCD normal/reverse switching
F9	Reserved
F10	Reserved
F11	Power management mode switching (Toggles High power, Intelligent, Economy)
F12	Hibernation invocation

How To Run the Keyboard Diagnostics

Do the following to run the keyboard test.

1. Go to the advanced diagnostic screen menu by pressing **Ctrl+A** in Easy-Setup menu.
2. Go to the keyboard diagnostic test menu by pressing **Ctrl+K**.
3. Check that when each key is pressed, the key position on the keyboard layout on the screen changes to be a black square.

Note: When a Fn key is pressed, the black square briefly appears.

Product Overview

The following table shows a brief overview of the system features.

Models 355x, 360x

Feature	Description
Processor	<ul style="list-style-type: none">• 355x, 360, 360C, 360Cs, 360P<ul style="list-style-type: none">– SL Enhanced 486SX 33 MHz, solder mounted on the system board• 360CE, 360CSE, 360PE<ul style="list-style-type: none">– SL Enhanced 486DX2 50/25 MHz, on the system board
Bus Architecture	<ul style="list-style-type: none">• AT Bus• VESA local bus for video subsystem
Memory (Standard)	4MB (on the system board)
Memory (Option)	2, 4, 8, 16MB, Basic IC DRAM card (max. 16 MB)
CMOS RAM	128 Bytes
VGA Video	<ul style="list-style-type: none">• 355, 360<ul style="list-style-type: none">– 9.5-inch (diagonally), 64 gray level, STN LCD monochrome• 355Cs, 360Cs, 360CSE, 360P, 360PE<ul style="list-style-type: none">– 9.5-inch (diagonally), 256/4096 color, DSTN LCD color• 355C, 360C, 360CE<ul style="list-style-type: none">– 8.4-inch (diagonally), 256/256K color, TFT LCD color
Diskette Drive (Removable)	0.720, 1.2, 1.44MB (3-mode), 3.5-inch
Hard Disk Drive (Removable)	<ul style="list-style-type: none">• 355x<ul style="list-style-type: none">– 125MB, 2.5-inch– 250MB, 2.5-inch• 360x<ul style="list-style-type: none">– 170MB, 2.5-inch– 340MB, 2.5-inch
Audio Card	<ul style="list-style-type: none">• Standard (360PE)• Option (other Model 360x)
Internal Modem Card	<ul style="list-style-type: none">• Standard (355x)• Option (360x)
PCMCIA	<ul style="list-style-type: none">• 360x<ul style="list-style-type: none">– One Type-III or Two Type-II• 355x<ul style="list-style-type: none">– One Type-III or Type II

Model 370C

Feature	Description
Processor	IntelDX4 75MHz on the system board
Bus Architecture	<ul style="list-style-type: none"> • AT Bus • VESA Local Bus for video subsystem
Memory (Standard)	4MB (on the system board)
Memory (Option)	<ul style="list-style-type: none"> • 2, 4, 8, 16MB, Basic IC DRAM card (max. 16 MB) • 4, 8, 16MB, DIMM card (max. 32 MB) • DIMM card adapter
CMOS RAM	128 Bytes
VGA Video	<ul style="list-style-type: none"> • 10.4-inch (diagonally), 256/256K colors TFT LCD color
Diskette Drive (Removable)	<ul style="list-style-type: none"> • 0.720, 1.2, 1.44MB (3-mode), 3.5-inch
Hard Disk Drive (Removable)	<ul style="list-style-type: none"> • 340MB, 2.5-inch • 540MB, 2.5-inch • 810MB, 2.5-inch
Audio Card	Standard in Japan and European countries.
PCMCIA	One Type-III or two Type II

Model 750x

Feature	Description
Processor	<ul style="list-style-type: none"> • 750x <ul style="list-style-type: none"> – 486SL 33MHz, solder-mounted on the system board • 750Ce <ul style="list-style-type: none"> – SL Enhanced 486DX2 50MHz on the processor card
Bus Architecture	<ul style="list-style-type: none"> • AT Bus • VESA Local Bus for video subsystem (750Ce)
Memory (Standard)	4MB (on the system board)
Memory (Maximum)	2, 4, 8, 16MB, IC DRAM card (max. 20 MB)
CMOS RAM	<ul style="list-style-type: none"> • 750x <ul style="list-style-type: none"> – 256 Bytes • 750Ce <ul style="list-style-type: none"> – 128 Bytes

Feature	Description
VGA Video	<ul style="list-style-type: none"> • 750 <ul style="list-style-type: none"> – 9.5-inch (diagonally), 64 gray level, STN LCD monochrome • 750C, 755Ce <ul style="list-style-type: none"> – 10.4-inch (diagonally), 256 color, TFT LCD color • 750Cs <ul style="list-style-type: none"> – 9.5-inch (diagonally), 256 color, STN LCD color • 750P <ul style="list-style-type: none"> – 9.5-inch (diagonally), 64 gray level, STN LCD monochrome
Diskette Drive (Removable)	0.720, 1.2, 1.44, 2.88MB (4-mode), 3.5-inch
Hard Disk Drive (Removable)	<ul style="list-style-type: none"> • 170MB, 2.5-inch • 340MB, 2.5-inch
Audio Card	Standard
PCMCIA	One Type-III or Two Type-II

Models 755C, 755Cs

Feature	Description
Processor	<ul style="list-style-type: none"> • SL Enhanced 486DX2 50MHz, on the system board • 486DX4 75MHz, on the processor card
Bus Architecture	<ul style="list-style-type: none"> • AT Bus • VESA Local Bus for video subsystem
Memory (Standard)	4MB (on the system board)
Memory (Option)	<ul style="list-style-type: none"> • 2, 4, 8, 16MB, IC DRAM card (max. 16 MB) • 4, 16MB, DIMM card (max. 32 MB) • DIMM card adapter
CMOS RAM	128 Bytes
VGA Video	<ul style="list-style-type: none"> • 755C <ul style="list-style-type: none"> – 10.4-inch (diagonally), 256/256K color, TFT LCD color – 10.4-inch (diagonally), 256/226K color, TFT LCD color • 755Cs <ul style="list-style-type: none"> – 9.5-inch (diagonally), 256/4096 color, DSTN LCD color
Diskette Drive (Removable)	<ul style="list-style-type: none"> • 0.720, 1.2, 1.44MB (3-mode), 3.5-inch • 0.720, 1.2, 1.44, 2.88MB (4-mode), 3.5-inch
Hard Disk Drive (Removable)	<ul style="list-style-type: none"> • 170MB, 2.5-inch • 340MB, 2.5-inch • 540MB, 2.5-inch
Audio Card	Microphone and headphone jacks with built-in microphone
PCMCIA	One Type-III or two Type II

FRU Removals and Replacements

This section contains information about removals and replacements.

- The system board is sensitive to, and can be damaged by, electrostatic discharge. Establish personal grounding by touching a ground point with one hand before touching these units.

An electrostatic discharge (ESD) strap must be used to establish personal grounding.

- Do not damage any part. Only certified trained personnel should service the computer.
- The arrows in the “Removals and Replacements” section show the direction of movement to remove a FRU, or to turn a screw to release the FRU. The arrows are marked in numeric order, in square callouts, to show the correct sequence of removal.
- When other FRUs must be removed before removing the failing FRU, they are listed at the top of the page.
- To replace a FRU, reverse the removal procedure and follow any notes that pertain to replacement. See “Locations” for internal cable connections and arrangement information.
- When replacing a FRU, use the correct screw size as shown in the procedures.

Safety Notice 8: Translation on page 13

Before removing any FRU, power-off the computer, unplug all power cords from electrical outlets, remove the battery pack, and then disconnect any interconnecting cables.

Safety Notice 3: Translation on page 9

The battery pack contains small amounts of nickel. Do not disassemble it, throw it into fire or water, or short-circuit it. Dispose of the battery pack as required by local ordinances or regulations.

Safety Notice 1: Translation on page 7

Before the computer is powered-on after FRU replacement, make sure all screws, springs, or other small parts, are in place and are not left loose inside the computer. Verify this by shaking the computer and listening for rattling sounds. Metallic parts or metal flakes can cause electrical shorts.

Removals Models 355x, 360x

1010 Rear Connector Door

Remove the center latch **1**; then remove the rear connector door by flexing it **2**.

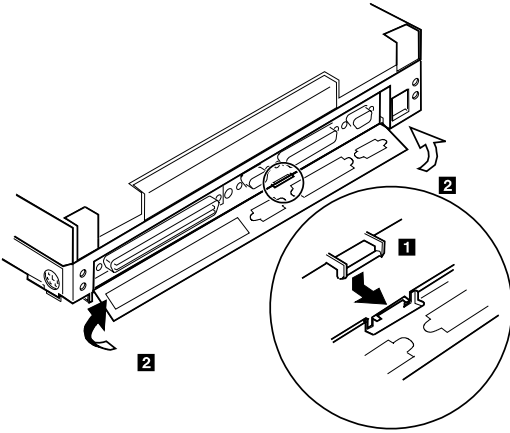

1015 Foot

To replace the foot:

- Align the foot in the open position with one pivot in its hinge in the base cover
- Press the other pivot point into position with your thumb or finger

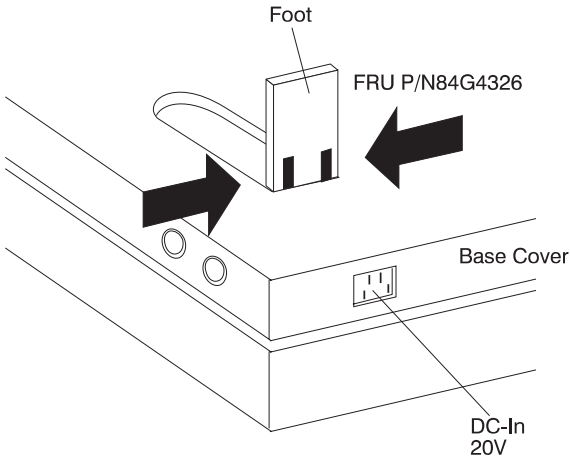

1020 Battery Pack

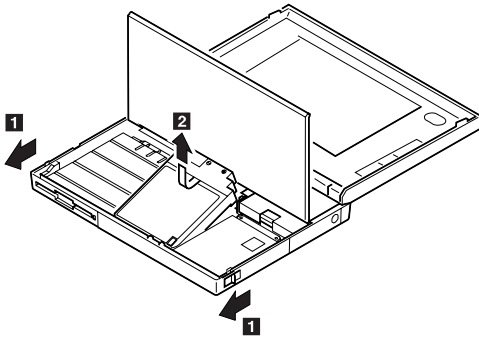

Notes:

1. Be careful that the computer does not fall backward when the battery pack is removed.
2. Check that the keyboard latch springs are in place.

1030 Diskette Drive

- Battery Pack (1020)

Warning:

1. **Check that the backup and standby batteries are seated correctly to prevent damage to the diskette drive.**
2. **Do not put any pressure on the diskette drive cover.** Remove the diskette drive exactly as shown in the figure.
3. **Make sure that a diskette is not installed in the drive.** Removing the drive with a diskette installed causes bending or damaging the eject button.

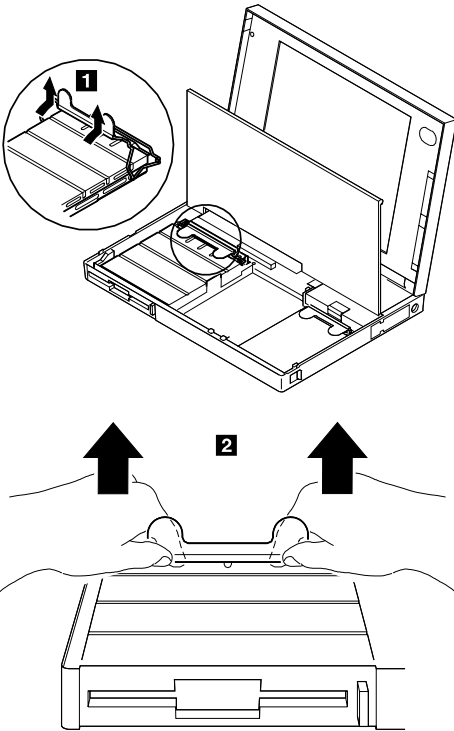

After replacing the diskette drive, latch the removal strap into the correct position.

1035 Hard Disk Drive

- Battery Pack (1020)

Warning:

1. **Do not apply any extra force to the hard disk drive when removing it.** Remove the hard disk drive exactly as shown in the figure.
2. **Do not drop or apply any shock to the hard disk drive.** The hard disk drive is sensitive to physical shock. Incorrect handling can damage it or cause permanent loss of data. Before removing the hard disk drive, have the user make a backup copy of all information on the hard disk. Never remove the hard disk drive while the system is operating or is in suspend mode.

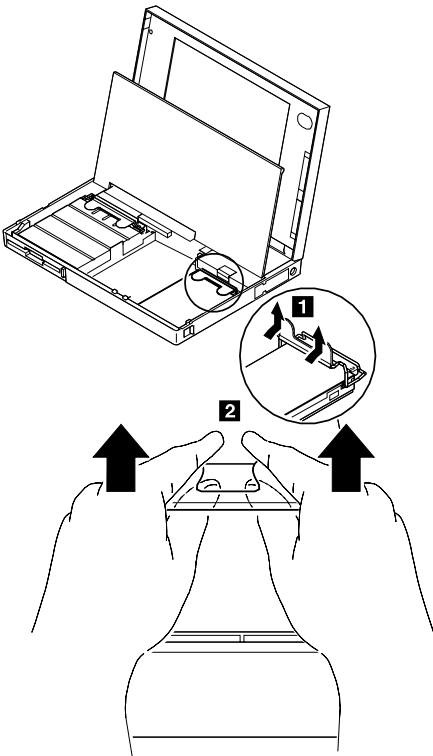

After replacing the hard disk drive, latch the removal strap into the correct position.

1040 Keyboard Unit

- Battery Pack (1020)

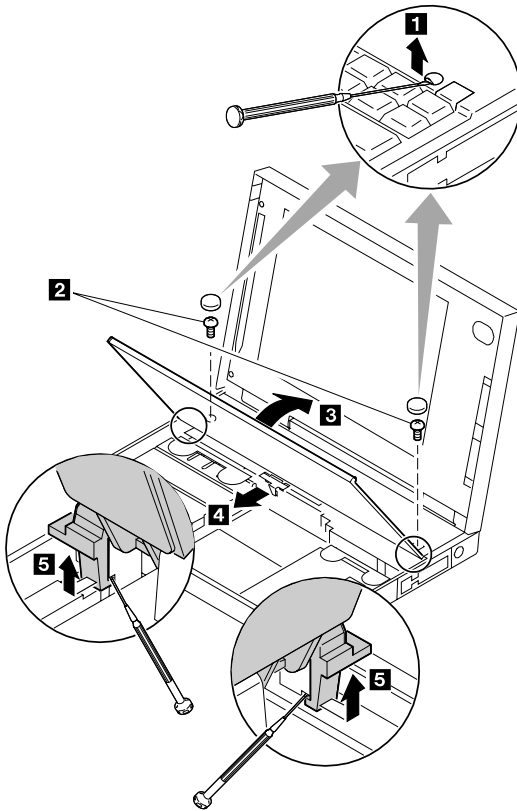

- 1** When removing the screw covers, use a small screwdriver as shown.
- 2** **Warning:** When using a screwdriver to remove cover or latches, be careful not to:
 - **Scratch the surface of the computer.**
 - **Break the latches.**
- 3** Open the keyboard.
- 4** Remove the leaf-spring plate.
- 5** When unlatching the upper cover latches to remove the upper cover, use a small screwdriver as shown.

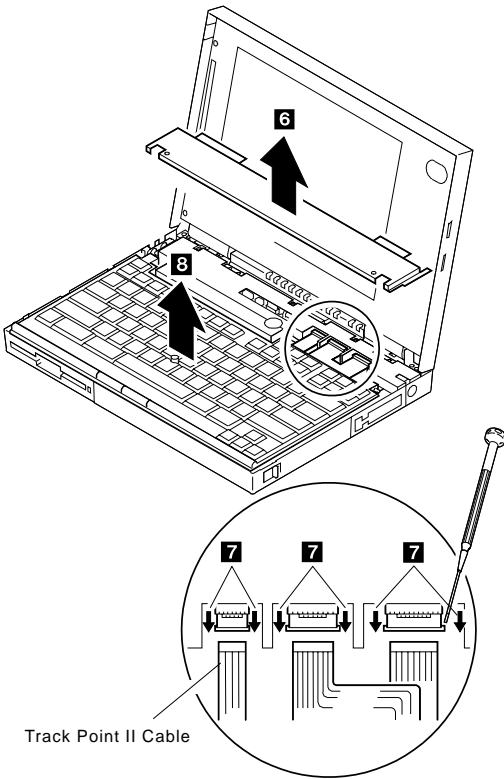

Track Point II Cable

- 6** Remove the upper cover.
Note: To remove the upper cover, do not latch the keyboard. Lower the keyboard and remove the upper cover.
- 7** Disconnect the cables to remove the keyboard unit as shown.
Warning: Do not pull the keyboard cables. The keyboard cables can be damaged if the keyboard is disconnected without releasing the three latches **7**.
- 8** Remove the keyboard.

Use the following table for reference when replacing parts.

Step	Location (Quantity)	Length
2	Upper cover (2)	8 mm
Note: Make sure you use the correct screw.		

Notes for when replacing:

1. When replacing the keyboard, check that the three cables are clean, and inserted straight and fully into the connectors. Slide both ends of each latch at the same time to make sure that each cable is correctly inserted.

Warning: While pressing the cables into place, be careful not to break the flexible cables.

Go to “Keyboard/Auxiliary Input Device Checkout” on page 203 and test all keys before returning the computer to the customer.

2. When replacing the upper cover, insert the two latches located on the rear side of the cover into the guide of the LCD foot; then push the right, left, and front sides to snap them into place. **Be careful not to damage the suspend/resume switch when putting on the cover.**

1050 IC DRAM Card

- Battery Pack (1020)
- Diskette Drive (1030)

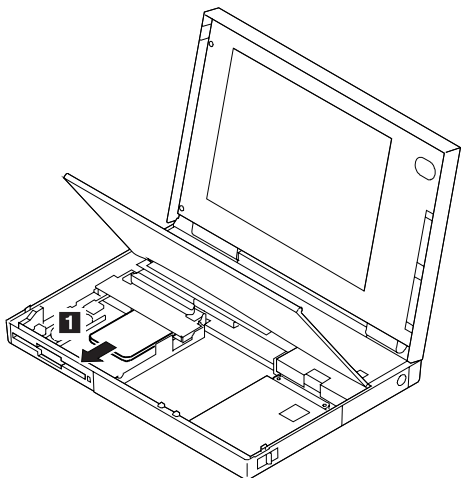

Warning: The IC DRAM card is sensitive to physical shock. Incorrect handling of the card can damage it. The eject tape (P/N 53G9318) must be used to remove the card.

1055 Diskette Drive Bezel

- Battery Pack (1020)
- Diskette Drive(1030)

Insert a coin between the diskette drive bezel and the computer as shown **1** and push the bezel from the bottom of the computer **2** to remove it.

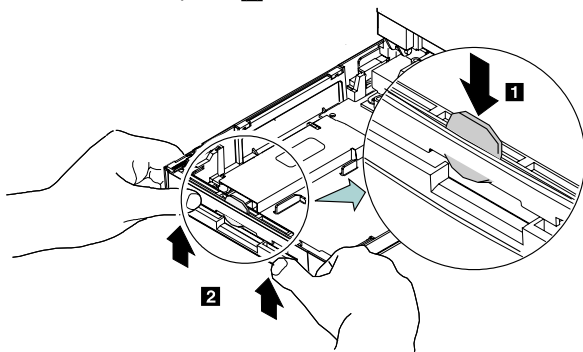

1060 Status Indicator

- Battery Pack (1020)
- Keyboard Unit (1040)

Warning: Do not pull the status indicator cable. The cable can be damaged if the indicator is disconnected (in step 2) without releasing the latch.

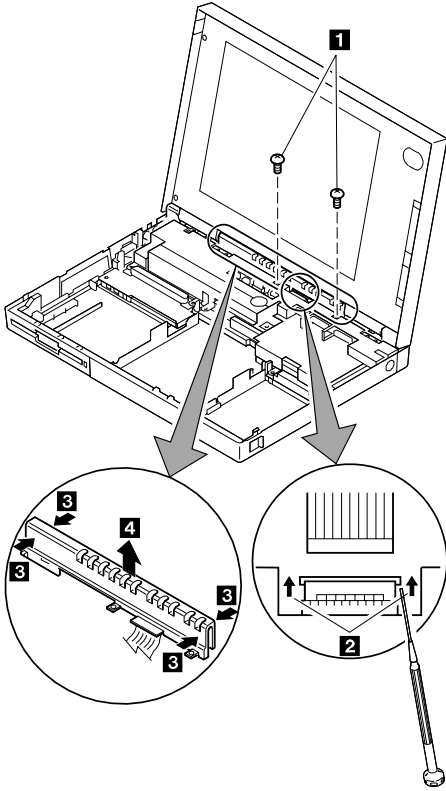

The status indicator has three latches on its rear side and one on its front side. For step **3**, do the following:

1. Release the rear latches by pushing each one with your thumb, as shown in the figure. (The broken circles in the figure show the locations of the three latches.)
2. Release the front latch.
3. Lift the indicator.

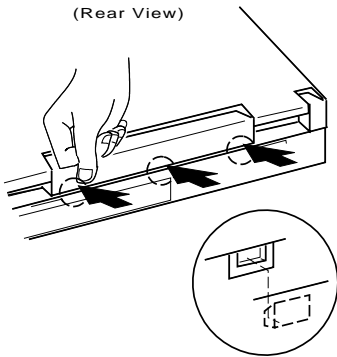

Note: When replacing the indicator, insert the flexible cable straight into the connector until the head of the cable stops. Slide both ends of the latches at the same time to make sure that the cable is correctly inserted.

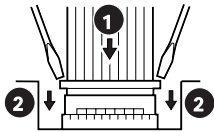

Use the following table for reference when replacing parts.

Step	Location (Quantity)	Length
1	Indicator bracket (2)	4 mm
Note: Make sure you use the correct screw.		

1070 LCD Assembly

- Battery Pack (1020)
- Keyboard Unit (1040)
- Status Indicator (1060)

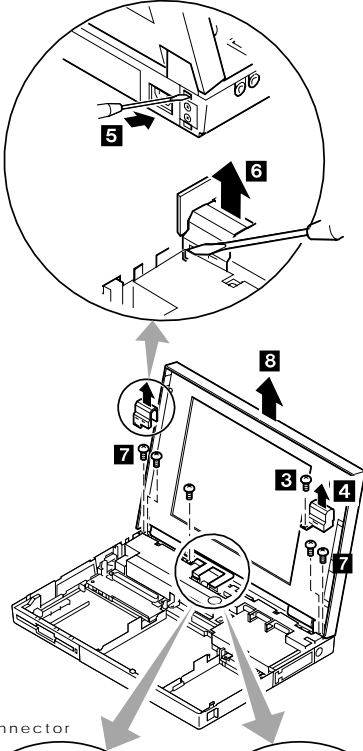

LCD Connector

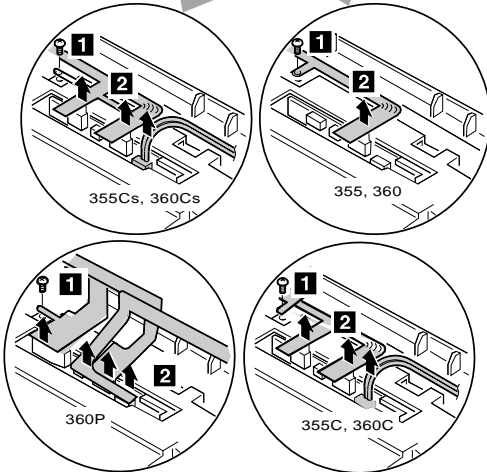

- 1** When replacing the LCD ground-terminal screw, do not pull or push the LCD cables.

- 2 When removing the LCD cables, pull the connector straight up. Incorrect handling can damage the connector.
Note: For the color model, make sure the indicator does not hook the most right LCD connector when replacing the status indicator.
- 3 Remove the screw.
- 4 Remove the right hinge cover.
- 5 When removing the left hinge cover, use a small screwdriver as shown to release the latch from the rear base cover. Pull the hinge cover slightly upward to keep it unlatched.
- 6 From the front side, remove the latch with a small screwdriver as shown to remove the cover. **Be careful not to scratch the surface of the computer when you use a screwdriver to remove the latches.**
- 7 Remove the four screws.

Use the following table for reference when replacing parts.

Step	Location (Quantity)	Length
1	LCD ground-terminal (1)	4 mm
3	LCD hinge cover, right (1)	4 mm
7	LCD hinge (4)	4 mm
Note: Make sure you use the correct screw.		

Safety Notice 5: Translation on page 11

If the LCD breaks and the fluid from inside the LCD gets into your eyes or on your hands, immediately wash the affected areas with water for at least 15 minutes. Seek medical care if any symptoms from the fluid are present after washing.

Caring for the LCD

- When cleaning of the LCD becomes necessary, gently wipe the LCD with a dry, soft cloth. Do not use alcohol or detergent to clean the LCD.
- To avoid damage to the LCD, do not scratch or apply any force to its surface.
- Do not put anything on the surface of the LCD.

1080 Modem Card (355x)

1085 Bezel (360x)

- Battery Pack (1020)
- Diskette Drive (1030)
- Hard Disk Drive (1035)
- Keyboard Unit (1040)
- Status Indicator (1060)

Notes:

1. For Model 360x, use steps **9** through **12** to remove the bezel.
2. When the audio card is installed in Model 360x, modem card means audio card in the following step.

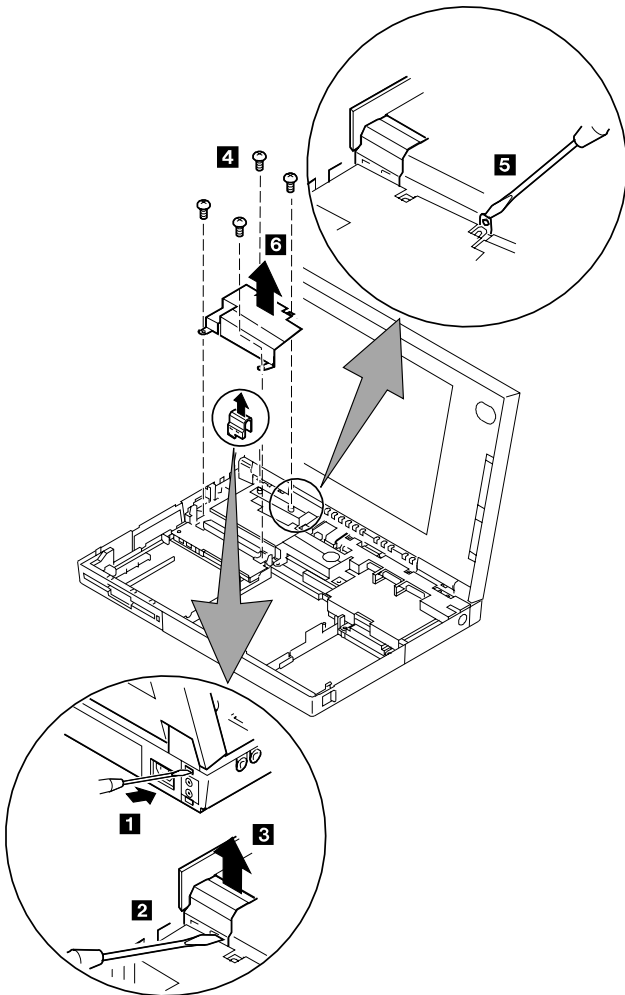

For the modem card:

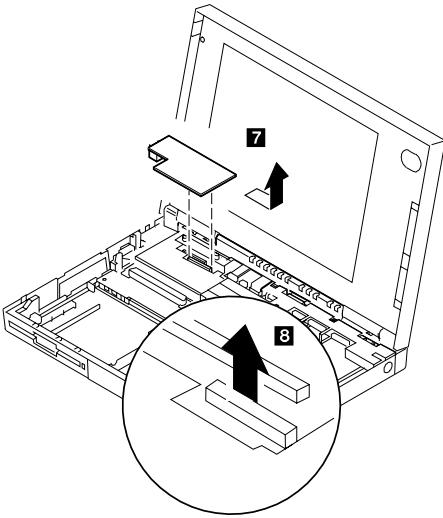

or

For the audio card:

Notes:

1. Gently lift the audio card in step **7** to avoid damaging the speaker cable.
2. Do not pull the speaker cable **8** before the audio card is removed **7**.

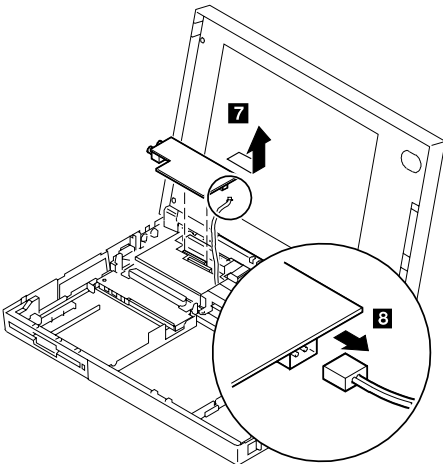

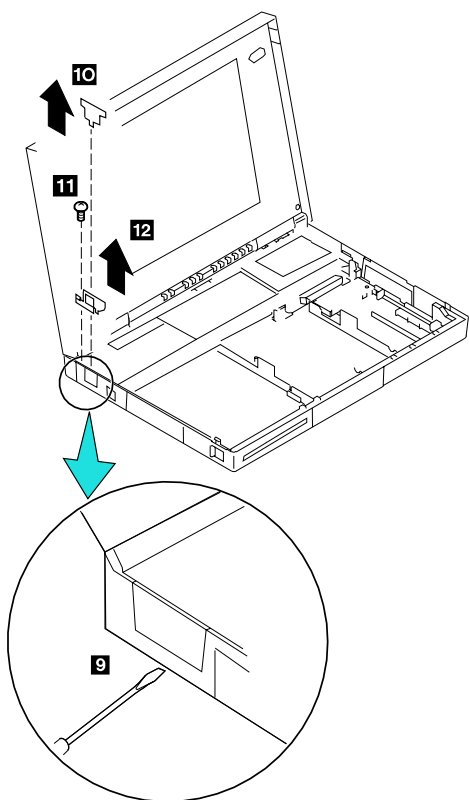

Use the following table for reference when replacing parts.

Step	Location (Quantity)	Length
1a	Speaker shield (2)	4 mm
1b	Diskette drive connector (2)	6 mm
5	Lower Shield (2)	4 mm

Note: Make sure you use the correct screw.

Note: When you reinstall the upper shield, make sure the LCD ground-terminal is located correctly as shown in the circle.

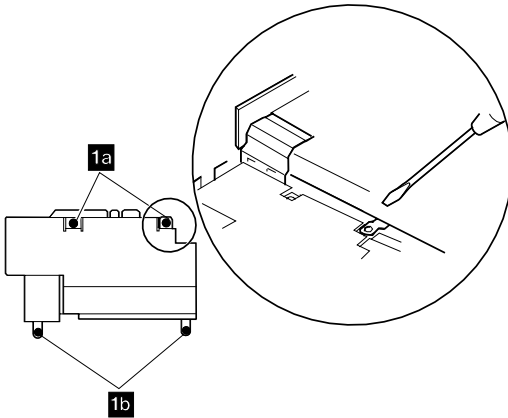

1090 Speaker Shield Assembly

1095 Interposer Card

- Battery Pack (1020)
- Diskette Drive (1030)
- Hard Disk Drive (1035)
- Keyboard Unit (1040)
- Status Indicator (1060)
- LCD Assembly (1070)
- Modem Card (1080)

Warning: Carefully remove any metal particles that might have flaked off. Be careful not to damage it with a screwdrivers, screws, or other objects.

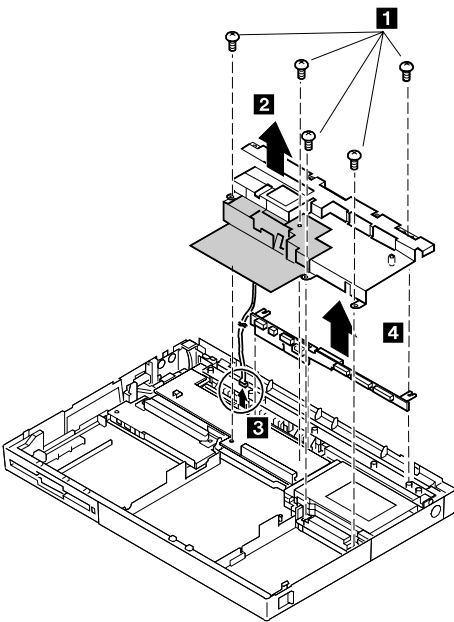

- 2** When replacing the speaker shield, insert it under the projection at the left, rear corner of the computer base.

Note: The shaded part in the figure is attached to the speaker shield assembly with light adhesive. This is a separate FRU from the speaker shield assembly.

- 3** When raising the speaker shield assembly, make sure that the shield assembly does not hook the three flexible cables of the keyboard. For Model 360, gently raise the speaker shield assembly to avoid damaging the speaker cable. (For Models 355 and 355Cs, skip step **3**; the speaker cable has already been removed.)

Use the following table for reference when replacing parts.

Step	Location (Quantity)	Length
1a	Speaker shield (1)	4 mm
1b	Hard disk drive connector (2)	6 mm
1c	System board (1)	16 mm
1d	System board, spacer (1)	16 mm

Note: Make sure you use the correct screw.

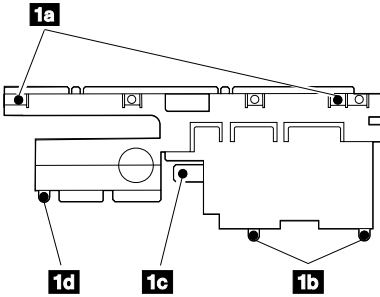

Notes:

1. Verify that the spacer **1d** is in the correct position.
2. **2** is a shield for radio frequency interference.

1100 DC/DC Card

- Battery Pack (1020)
- Diskette Drive (1030)
- Hard Disk Drive (1035)
- Keyboard Unit (1040)
- Status Indicator (1060)
- LCD Assembly (1070)
- Speaker Shield Assembly (1090)
- Modem Card (1080)
- Interposer Card (1095)

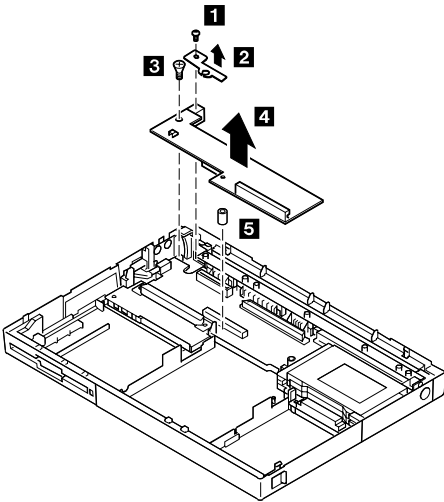

Notes:

1. When replacing the DC/DC card, put the spacer **5** on the screw hole.
2. DC-in holder **A** and spacer **5** are supplied as miscellaneous parts.

Use the following table for reference when replacing parts.

Step	Location (Quantity)	Length
3	Power jack (1)	8 mm (flat head)
Note: Make sure you use the correct screw.		

1110 Backup Battery

1115 Standby Battery

- Battery Pack (1020)
- Diskette Drive (1030)

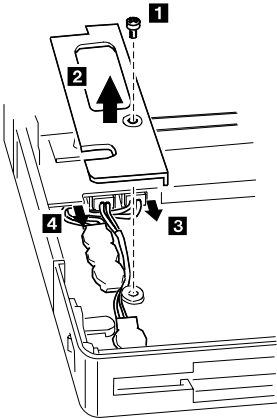

- 4** Backup Battery
- 3** Standby Battery

Note: When replacing the batteries, make sure both are seated correctly. Check that the insulator cover **1** is in the correct position by sliding its end to end.

Step	Location (Quantity)	Length
1	cover (1)	4 mm
Note: Make sure you use the correct screw.		

Safety Notice 2: Translation on page 8

The standby battery contains a small amount of nickel and cadmium. Do not disassemble it, recharge it, throw it into fire or water, or short-circuit it. Dispose of the battery as required by local ordinances or regulations.

Safety Notice 4: Translation on page 10

The backup battery is a lithium battery and can cause a fire, explosion, or severe burn. Do not recharge it, remove its polarized connector, disassemble it, heat it above 100°C (212°F), incinerate it, or expose its cell contents to water. Dispose of the battery as required by local ordinances or regulations. Use of an incorrect battery can result in ignition or explosion of the battery. Replacement batteries can be ordered from IBM or IBM Authorized Dealers.

1120 System Board Assembly

- Battery Pack (1020)
- Diskette Drive (1030)
- Hard Disk Drive (1035)
- Keyboard Unit (1040)
- Status Indicator (1060)
- LCD Assembly (1070)
- Modem Card (1080)
- Speaker Shield Assembly (1090)
- Interposer Card (1095)
- DC/DC Card (1100)
- Backup Battery (1110)
- Standby Battery (1115)

Important

The EEPROM on the system board contains the vital product data (VPD), that is, system unit serial number, system board serial number, and other computer unique data. When the system board is replaced, the system unit serial number must also be restored. Use the **Set system identification** utility on the maintenance diskette to restore the number.

Do not power-off the computer when restoring the VPD.

The serial number label is attached to the bottom cover.

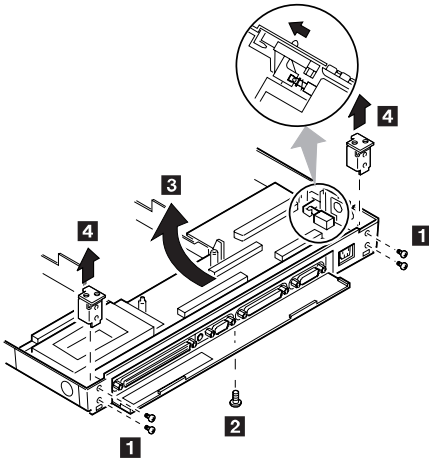

Notes:

1. Before removing and replacing the system board, make sure that the PCMCIA cards are removed and the eject levers are not sticking out.
2. When replacing the system board assembly, align the power-key slide hub with the power-switch actuator by moving the power-key in the direction of the arrow. See the large circle in the figure. Before tightening any screws, check that the power-switch operates correctly.
3. Do not pull the PCMCIA slot assembly while removing the system board.

Use the following table for reference when replacing parts.

Step	Location (Quantity)	Length
1	Hinge bracket (4)	4 mm
2	Base cover, lower shield (1)	4 mm
Note: Make sure you use the correct screw.		

1130 PCMCIA Slot Assembly

- Battery Pack (1020)
- Diskette Drive (1030)
- Hard Disk Drive (1035)
- Keyboard Unit (1040)
- Status Indicator (1060)
- LCD Assembly (1070)
- Modem Card (1080)
- Speaker Shield Assembly (1090)
- Interposer Card (1095)
- DC/DC Card (1100)
- Backup Battery (1110)
- Standby Battery (1115)
- System Board Assembly (1120)

Warning: The system board can be damaged if the lower shield touches the system board components. Carefully follow the next instruction.

In step **4**, gradually raise the system board from the lower shield until all the components of the system board just clear the tabs of the lower shield. Be careful not to raise it too far. While keeping the clearance to a minimum, separate the system board from the lower shield by moving the system board straight forward as shown by step **2**.

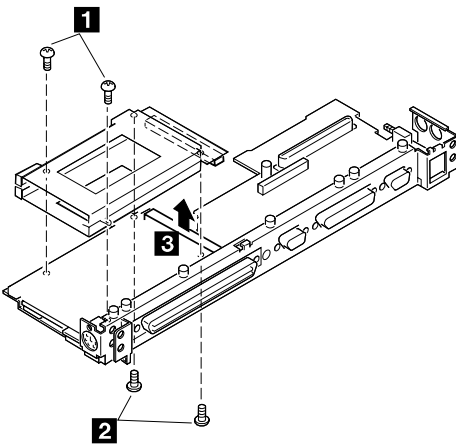

Notes:

1. When handling the PCMCIA slot assembly, be careful not to disassemble any part of it. The slot assembly is not solidly fixed when it is removed from the system board or the FRU.
2. The screw stand-off located each corner of the PCMCIA slot, is easy to remove. Make sure that the screw stand-off is positioned when replacing the slot. Do not replace the slot without the screw stand.

Use the following table for reference when replacing parts.

Step	Location (Quantity)	Length
1	PCMCIA slot, upper (2)	12 mm
2	PCMCIA slot, lower (2)	14 mm
Note: Make sure you use the correct screw.		

Removals Models 370C, 750x, 755C, 755Cs

2010 Rear Connector Door

Remove the center latch **1**; then remove the rear connector door by flexing it **2**.

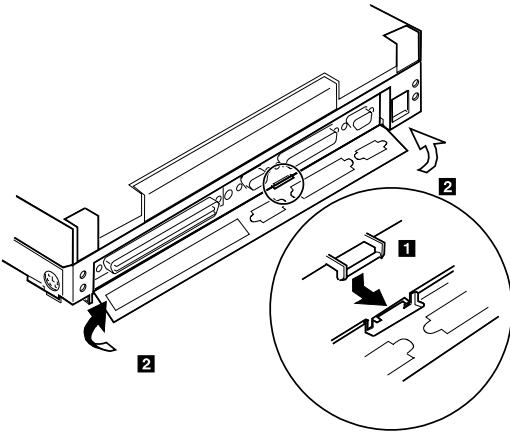

2015 Foot

To replace the foot:

- Align the foot in the open position with one pivot in its hinge in the base cover
- Press the other pivot point into position with your thumb or finger

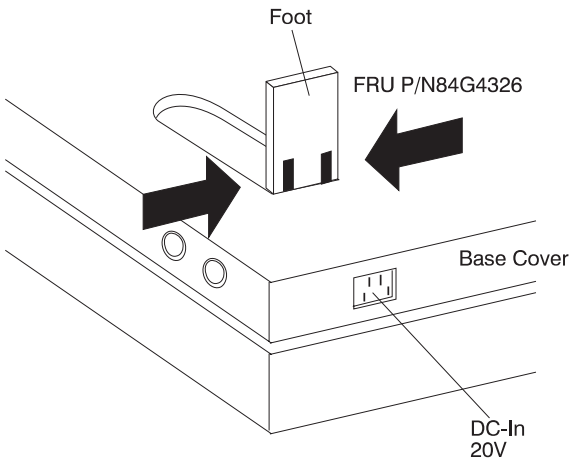

2020 Battery Pack

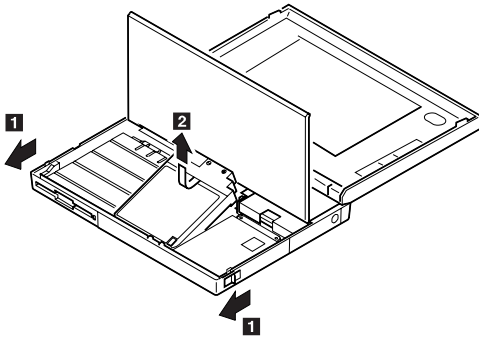

Notes:

1. Be careful that the computer does not fall backward when the battery pack is removed.
2. When replacing the battery pack, check that the storage switch of the new battery is set to the on (I) position. Do not operate the storage switch of a battery that has been used and is going to be re-used.
3. Check that the keyboard latch springs are in place.

2030 Diskette Drive

- Battery Pack (2020)

Warning:

1. **Check that the backup battery and standby battery are seated correctly to prevent damage to the diskette drive** when replacing the diskette drive.
2. **Do not put any pressure on the diskette drive cover.** Remove the diskette drive exactly as shown in the figure.
3. **Make sure that a diskette is not installed in the drive.** Removing the drive with a diskette installed causes bending or damaging the eject button.

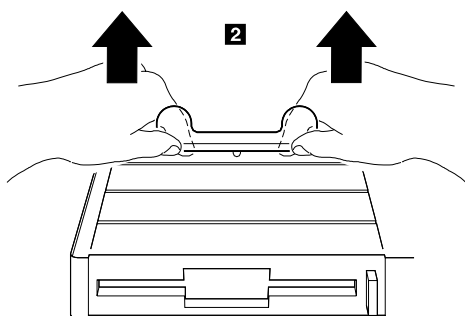
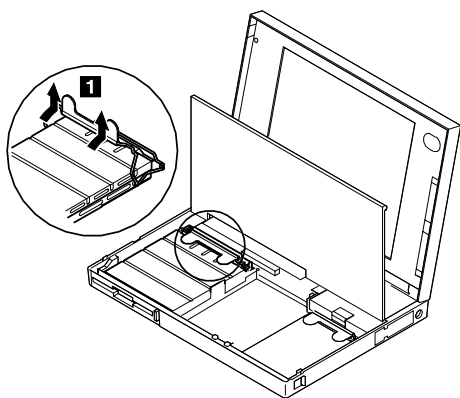

After replacing the diskette drive, latch the removal strap into the correct position.

2035 Hard Disk Drive

- Battery Pack (2020)

Warning:

1. **Do not apply any extra force to the hard disk drive when removing it.** Remove the hard disk drive exactly as shown in the figure.
2. **Do not drop or apply any shock to the hard disk drive.** The hard disk drive is sensitive to physical shock. Incorrect handling can cause damage it, and cause permanent loss of data on the hard disk. Before removing the hard disk drive, have the user make a backup copy of all the information on the hard disk. Never remove the hard disk drive while the system is operating or is in suspend mode.

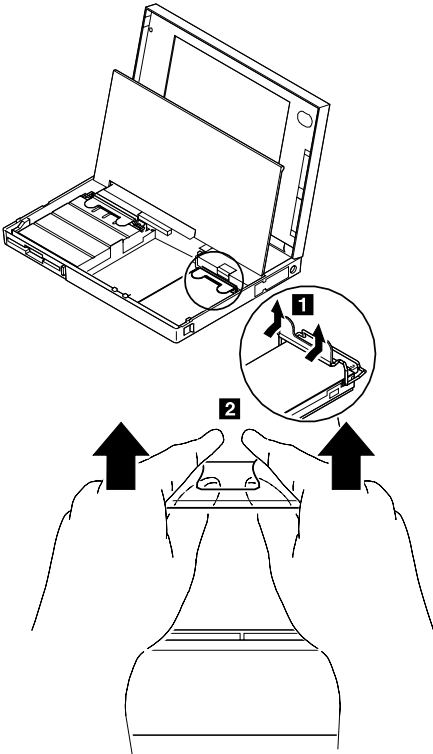

After replacing the hard disk drive, latch the removal strap into the correct position.

2040 Keyboard Unit

- Battery Pack (2020)

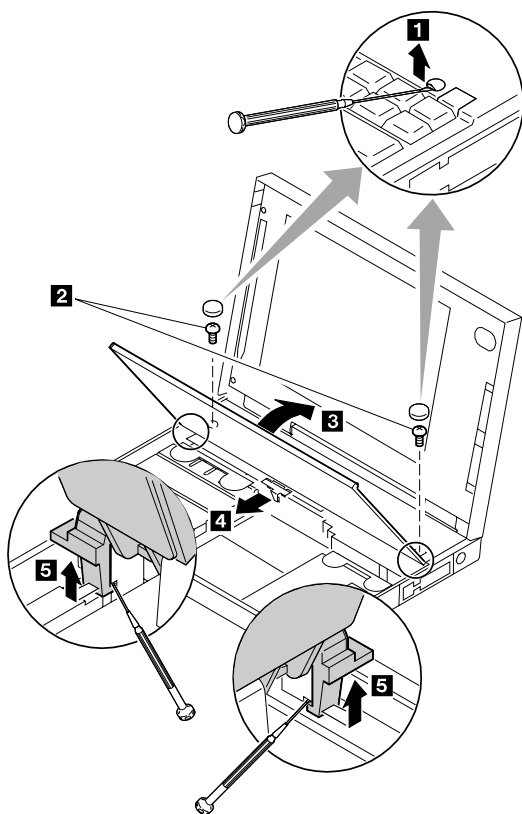

- 1** When removing the screw covers, use a small screwdriver as shown.
- 2** **Warning:** When using a screwdriver to remove cover or latches, be careful not to:
 - **Scratch the surface of the computer.**
 - **Break the latches.**
- 3** Open the keyboard.
- 4** Remove the leaf-spring plate.
- 5** When unlatching the upper cover latches to remove the upper cover, use a small screwdriver as shown.

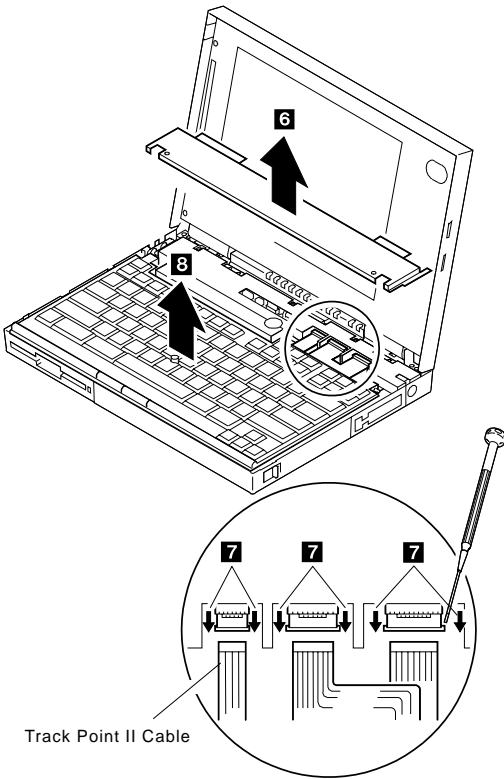

Track Point II Cable

- 6** Remove the upper cover.
Note: To remove the upper cover, do not latch the keyboard. Lower the keyboard and remove the upper cover.
- 7** Disconnect the cables to remove the keyboard unit as shown.
Warning: Do not pull the keyboard cables. The keyboard cables can be damaged if the keyboard is disconnected without releasing the three latches.
- 8** Remove the keyboard.

Use the following table for reference when replacing parts.

Step	Location (Quantity)	Length
2	Upper cover (2)	8 mm
Note: Make sure you use the correct screw.		

Notes for when replacing:

1. When replacing the keyboard, check that the three cables are clean, and inserted straight and fully into the connectors. Slide both ends of each latch at the same time to make sure that each cable is correctly inserted. Go to “Keyboard/Auxiliary Input Device Checkout” on page 203 and test all keys before returning the computer to the customer.
2. When replacing the upper cover, insert the two latches located rear side of the cover into the guide of the foot of the LCD; push the right, left, and front sides to snap into place. **Be careful not to damage the suspend/resume switch when putting on the cover.**

2050 IC DRAM Card

- Battery Pack (2020)
- Diskette Drive (2030)

For Models 370C, 755C and 755Cs, one of two types of memory card can be used, IC DRAM card or DIMM card.

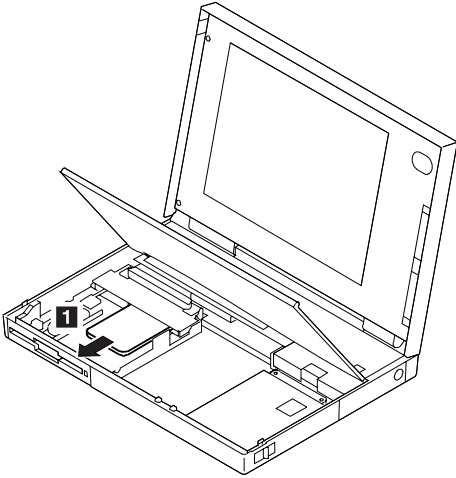

Warning: The IC DRAM card is sensitive to physical shock. Incorrect handling of the card can damage it. The eject tape (P/N 53G9318) must be used to remove the card.

Note: For Models 370C, 755C and 755Cs, one of the following combinations occupies the slot depending on the configuration.

- IC DRAM card + IC DRAM card base
- DIMMs on DIMM adapter

2055 DIMM and DIMM Adapter (755C, 755Cs)

- Battery Pack (2020)
- Diskette Drive (2030)

Press both locks at the same time and remove the DIMM.

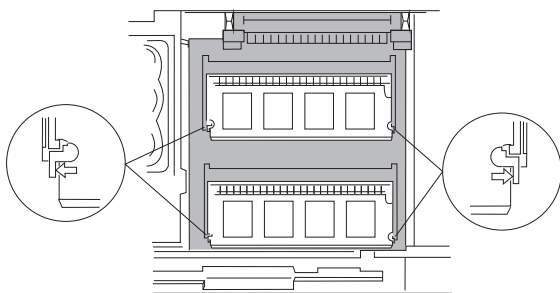

While holding the strap **1**, pull the DIMM adapter toward the front **2** to remove it.

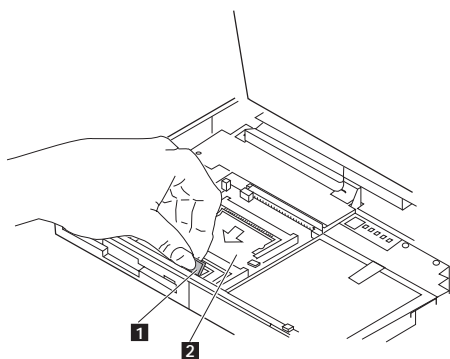

Notes:

1. If the IC DRAM cards or the DIMM are not installed and the base plate is installed instead of these card, remove the plate as follows:
 - a. Pinch the projection **1** on the left side of the plate; then pull the plate slightly toward the front **2**.
 - b. Raise the rear portion of the plate **3** and remove it.

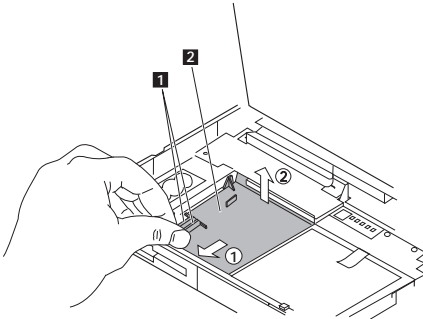

2. When inserting the DIMM into either connector on the DIMM adapter:
 - a. Locate the triangle **2** on the right side of the socket.
 - b. With the notched end of the DIMM **1** toward the triangle, insert the DIMM into the socket.
 - c. Pivot the DIMM until it snaps into place.

If you have another DIMM to install, insert it in the other socket the same way.

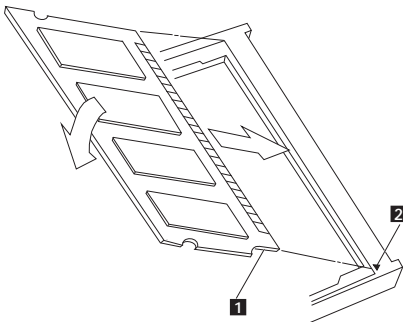

2056 Diskette Drive Bezel

- Battery Pack (2020)
- Diskette Drive(2030)

Insert a coin between the diskette drive bezel and the computer as shown **1** and push the bezel from the bottom of the computer **2** to remove it.

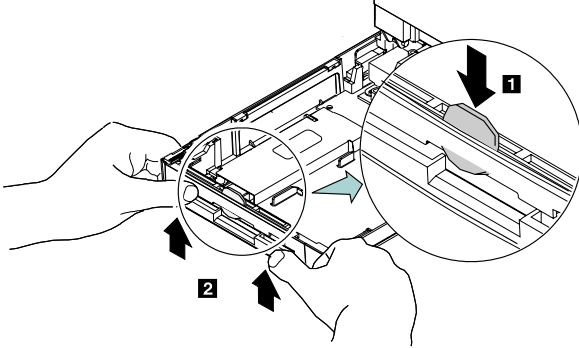

2060 Status Indicator

- Battery Pack (2020)
- Keyboard Unit (2040)

Warning: Do not pull the status indicator cable. The cable will be damaged if the status indicator is disconnected without releasing the latch in step **2**.

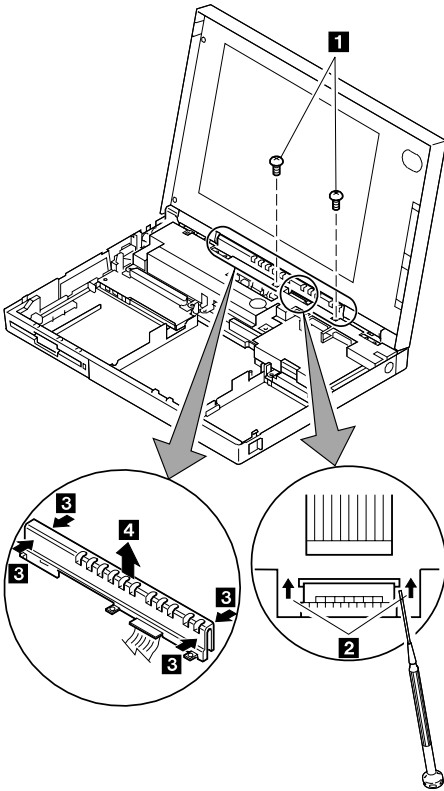

The status indicator has three latches on its rear and two in its front. In step **3**, do as follows:

1. Release the rear latches with pushing each one with your thumb, as shown in the artwork. (The broken circles in the figure show the locations of the three latches.)
2. Release the front latches.
3. Lift the indicator.

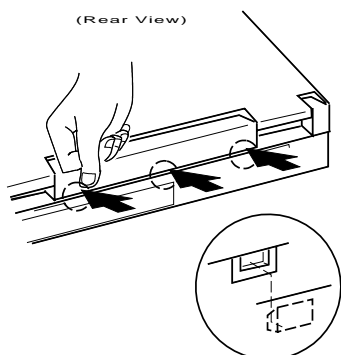

Note: When replacing the indicator, insert the flexible cable straight into the connector until the head of the cable stops. Slide both ends of the latches at the same time to make sure that the cable is correctly inserted.

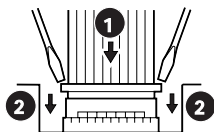

Use the following table for reference when replacing parts.

Step	Location (Quantity)	Length
1	Indicator bracket (2)	4 mm
Note: Make sure you use the correct screw.		

2070 LCD Assembly

- Battery Pack (2020)
- Keyboard Unit (2040)
- Status Indicator (2060)

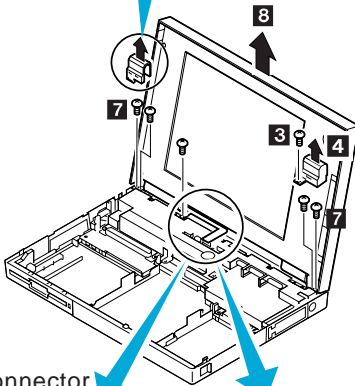
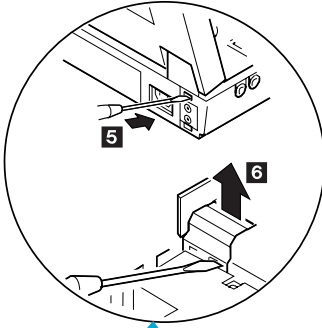

LCD Connector

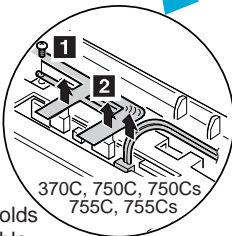

370C, 750C, 750Cs
755C, 755Cs

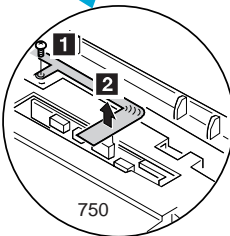

750

Screw holds
two flexible
cables.

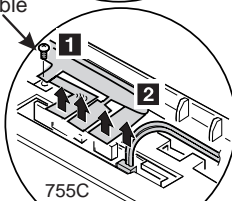

755C

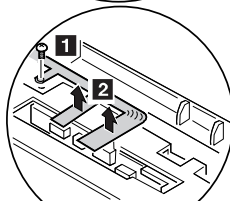

750P

This figure shows the LCD that
does not have a contrast control.
(P/N 84G4337)

Important

- Two types of LCDs are available for the Model 755C: one with a contrast control and one without. Make sure that you replace the LCD with the correct type.
- The LCD for the Model 370C does not have a contrast control.

1 When replacing the LCD ground-terminal screw, do not pull or push the LCD cables.

2 When removing the LCD cables, pull the connector straight up. Incorrect handling can damage the connector.

Note: For the color models, make sure the indicator does not catch the right LCD connector when replacing the status indicator.

3 Remove the screw.

4 Remove the right hinge cover.

5 When removing the left hinge cover, use a small screwdriver as shown to release the latch from the rear base cover. Pull the hinge cover slightly upward to keep it unlatched.

6 From the front side, remove the latch with a small screwdriver as shown to remove the cover. **Be careful not to scratch the surface of the computer when you use a screwdriver to remove the latches.**

7 Remove the four screws.

Use the following table for reference when replacing parts.

Step	Location (Quantity)	Length
1	LCD ground-terminal (1)	4 mm
3	LCD hinge cover, right (1)	4 mm
7	LCD hinge (4)	4 mm

Note: Make sure you use the correct screw.

Safety Notice 5: Translation on page 11

If the LCD breaks and the fluid from inside the LCD gets into your eyes or on your hands, immediately wash the affected areas with water for at least 15 minutes. Seek medical care if any symptoms from the fluid are present after washing.

Caring for the LCD

- When cleaning of the LCD becomes necessary, gently wipe the LCD with a dry, soft cloth. Do not use alcohol or detergent to clean the LCD.
- To avoid damaging the LCD, do not scratch or apply any force to its surface.
- Do not put anything on the surface of the LCD.

2080 Speaker Shield Assembly

- Battery Pack (2020)
- Diskette Drive (2030)
- Hard Disk Drive (2035)
- Keyboard Unit (2040)
- Status Indicator (2060)
- LCD Assembly (2070)

Models 750x, 755C, and 755Cs

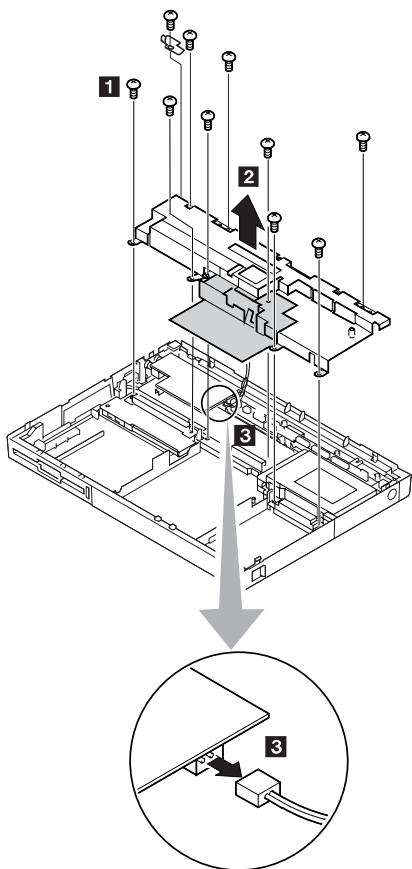

Model 370C

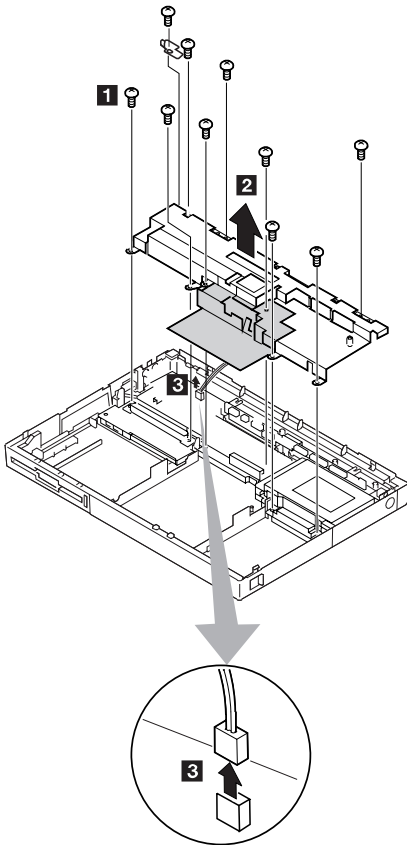

Important:

1. Carefully remove any metal particles that might have flaked off.
2. The shaded part in the figure is attached to the speaker shield assembly with light adhesive. This FRU is a separate FRU from the speaker shield assembly.

- 1** Remove the screws.
- 2** Gently raise the speaker shield assembly to avoid damaging the speaker cable and make sure that the shield assembly does not hook the three flexible cables of the keyboard.
- 3** Disconnect the speaker connector.

When Disconnecting the Connector

- Do not pull the speaker cable before the audio card is removed.
- Be careful not to damage the speaker with screwdrivers, screws, or other objects. A scratch will damage the speaker.
- When replacing the speaker shield, insert it under the projection at the left, rear corner of the computer base.

Use the following table for reference when replacing parts.

Step	Location (Quantity)	Length
1a	Speaker shield (4)	4 mm
1b	Hard disk drive connector (2)	6 mm
1c	System board (1)	16 mm
1d	System board, spacer (1)	16 mm
1e	Diskette drive connector (2)	6 mm

Note: Make sure you use the correct screw.

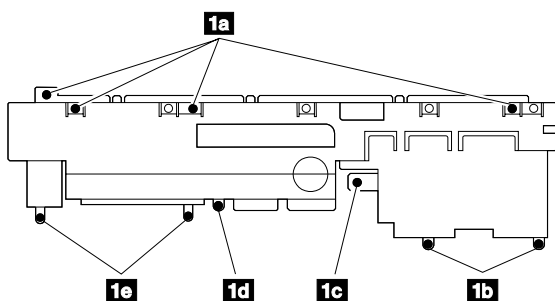

Notes:

1. **1d** shows the correct position of the spacer.
2. **2** is a shield for radio frequency interference.

2085 Audio Card

Note: Refer to “Product Overview” on page 232 to see whether the audio card is standard or not.

- Battery Pack (2020)
- Diskette Drive (2030)
- Hard Disk Drive (2035)
- Keyboard Unit (2040)
- Status Indicator (2060)
- LCD Assembly (2070)
- Speaker Shield Assembly(2080)

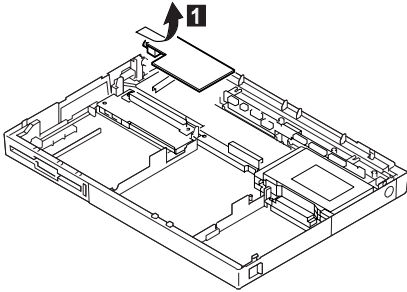

2090 Interposer Card

- Battery Pack (2020)
- Diskette Drive (2030)
- Hard Disk Drive (2035)
- Keyboard Unit (2040)
- Status Indicator (2060)
- LCD Assembly (2070)
- Speaker Shield Assembly (2080)
- Audio Card (2085)

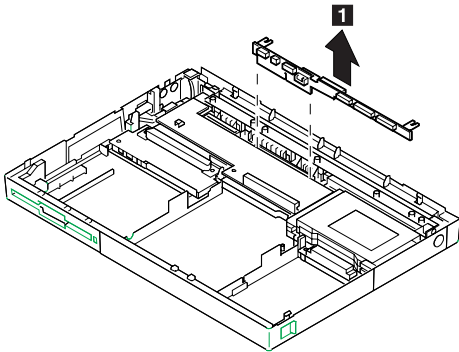

2100 DC/DC Card

- Battery Pack (2020)
- Diskette Drive (2030)
- Hard Disk Drive (2035)
- Keyboard Unit (2040)
- Status Indicator (2060)
- LCD Assembly (2070)
- Speaker Shield Assembly (2080)
- Audio Card (2085)
- Interposer Card (2090)

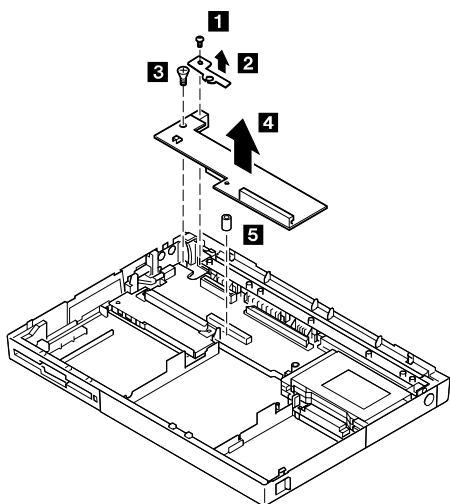

Notes:

1. When replacing the DC/DC card, put the spacer **5** on the screw hole.
2. DC-in holder **A** and spacer **5** are supplied as miscellaneous parts.

Use the following table for reference when replacing parts.

Step	Location (Quantity)	Length
3	Power jack (1)	8 mm (flat head)
Note: Make sure you use the correct screw.		

2110 Backup Battery

2105 Standby Battery

- Battery Pack (2020)
- Diskette Drive (2030)

Model 750x

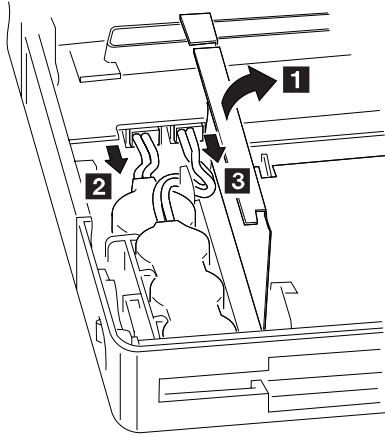

- 2** Standby Battery
- 3** Backup Battery

Models 370C, 755C, and 755Cs

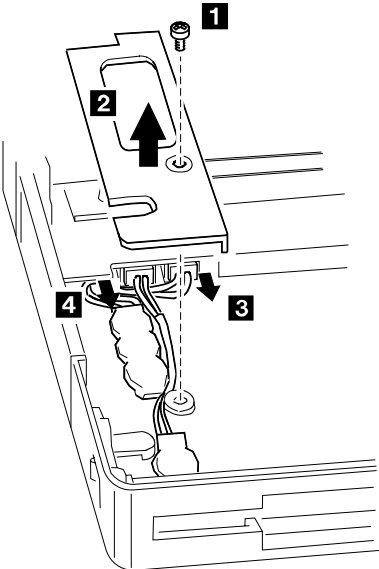

- 3** Standby Battery
- 4** Backup Battery

Note: When replacing the batteries, make sure the batteries are seated correctly. Make sure the insulator cover **1** is in the correct position by sliding it end to end.

Step	Location (Quantity)	Length
1	cover (1)	4 mm
Note: Make sure you use the correct screw.		

Safety Notice 2: Translation on page 8

The standby battery contains a small amount of nickel and cadmium. Do not disassemble it, recharge it, throw it into fire or water, or short-circuit it. Dispose of the battery as required by local ordinances or regulations.

Safety Notice 4: Translation on page 10

The backup battery is a lithium battery and can cause a fire, explosion, or severe burn. Do not recharge it, remove its polarized connector, disassemble it, heat it above 100°C (212°F), incinerate it, or expose its cell contents to water. Dispose of the battery as required by local ordinances or regulations. Use of an incorrect battery can result in ignition or explosion of the battery. Replacement batteries can be ordered from IBM or IBM Authorized Dealers.

2120 System Board Assembly

- Battery Pack (2020)
- Diskette Drive (2030)
- Hard Disk Drive (2035)
- Keyboard Unit (2040)
- Status Indicator (2060)
- LCD Assembly (2070)
- Speaker Shield Assembly (2080)
- Audio Card (2085)
- Interposer Card (2090)
- DC/DC Card (2100)
- Backup Battery (2110)
- Standby Battery (2105)

Important

The EEPROM on the system board contains the vital product data (VPD), that is, system unit serial number, system board serial number, and other computer unique data. When the system board is replaced, the system unit serial number must also be restored. Use the **Set system identification** utility on the maintenance diskette to restore the number.

Do not power-off the computer when restoring the VPD.

The serial number label is attached to the bottom cover.

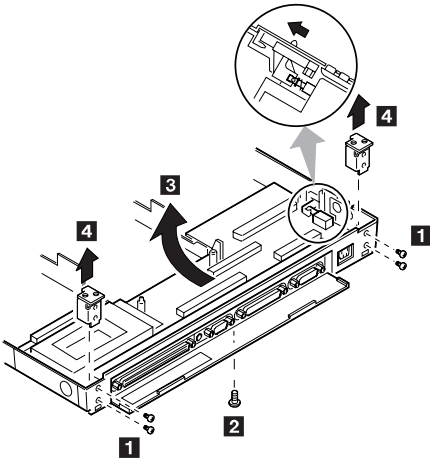

Notes:

1. For Model 755C, there are two types the system boards. Make sure the correct system board by checking the part number in the part list. After replacing the system board, run the display test from the Easy-Setup and use the **Pause** button to check the color graduations that are displayed after the **Video Page** screen. If the color blocks in one column are all the same color, replace the system board.
2. Before removing and replacing the system board, make sure that the PCMCIA cards are removed and the eject levers are not sticking out.
3. When replacing the system board assembly, align the power-key slide hub with the power-switch actuator by moving the power-key in the direction of the arrow. See the large circle in the figure. Before tightening any screws, check that the power-switch operates correctly.
4. Do not pull the PCMCIA slot assembly while removing the system board.

Use the following table for reference when replacing parts.

Step	Location (Quantity)	Length
1	Hinge bracket (4)	4 mm
2	Base cover, lower shield (1)	4 mm
Note: Make sure you use the correct screw.		

2130 PCMCIA Slot Assembly

- Battery Pack (2020)
- Diskette Drive (2030)
- Hard Disk Drive (2035)
- Keyboard Unit (2040)
- Status Indicator (2060)
- LCD Assembly (2070)
- Speaker Shield Assembly (2080)
- Audio Card (2085)
- Interposer Card (2090)
- DC/DC Card (2100)
- Backup Battery (2110)
- Standby Battery (2105)
- System Board Assembly (2120)

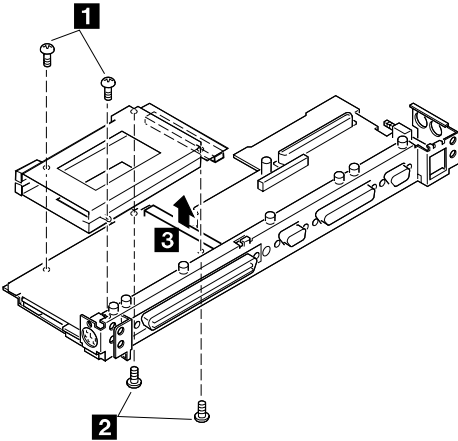

Notes:

1. When handling the PCMCIA slot assembly, be careful not to disassemble any part of it. The slot assembly is not solidly fixed when it is removed from the system board or the FRU.
In step 4, gently pull up the bottom of the center area of the connector board edge with your fingers.
2. The screw stand located each corner of the PCMCIA slot, is easy to remove. Make sure that the screw stand is located when replace the slot. Do not replace the slot without the screw stand.

Use the following table for reference when replacing parts.

Step	Location (Quantity)	Length
1	PCMCIA slot, upper (2)	12 mm
2	PCMCIA slot, lower (2)	14 mm
Note: Make sure you use the correct screw.		

2140 Processor Card (750Ce, 755C, 755Cs)

- Battery Pack (2020)
- Diskette Drive (2030)
- Hard Disk Drive (2035)
- Keyboard Unit (2040)
- Status Indicator (2060)
- LCD Assembly (2070)
- Speaker Shield Assembly (2080)
- Audio Card (2085)
- Interposer Card (2090)
- DC/DC Card (2100)
- Backup Battery (2110)
- Standby Battery (2105)
- System Board Assembly (2120)
- PCMCIA Slot Assembly (2130)

Warning: The system board can be damaged if the lower shield touches the system board components. Carefully follow the next instruction.

In step **3**, gradually raise the system board from the lower shield until all components of the system board just clear the tabs of the lower shield. Be careful not to raise it too far. While keeping the clearance to a minimum, separate the system board from the lower shield by moving the system board straight forward as shown by step **3**.

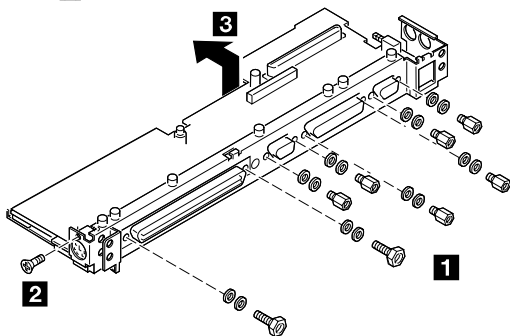

Note: In step **1**, each screw has a flat washer and a lock washer. When reinstalling the screws, make sure that the lock washer is placed next to the head of the screw. Incorrect washer placement can cause metal to flake.

Turn the system board upside down. Remove the screws **4** and **5**. Models 370C, 755C and 755Cs have only the screw on the right side in step **5**.

Notes:

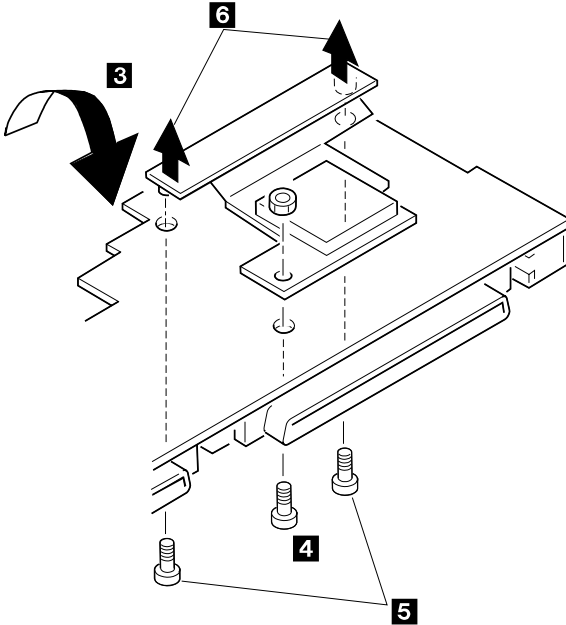

1. In step **1**, use 5.0 mm and 5.5 mm hex head screwdrivers. To remove the processor card, gently lift the area shown by **3** straight up. Do not pull the other areas.
2. In step **6**, pull both edges of the bracket at the same time. Do not pull the center of the bracket.

Use the following table for reference when replacing parts.

Step	Location (Quantity)	Length
1	Expansion bus, lower shield (2)	Hex head
1	I/O connector, lower shield (6)	Hex head
4	Processor card (1)	6 mm
5	Processor card connector 750x - (2), 370C, 755C, 755Cs - (1)	4 mm
Note: Make sure you use the correct screw.		

Locations

System - Front View (750, 750Cx, 755Cx, 370C, 360x, 355x)

- 1** LCD
- 2** Contrast Control

Note: The Model 360 does not have a contrast control. The Model 755C has one of two types of LCD: one with a contrast control and one without.

- 3** Brightness Control
- 4** Status Indicator
See "Status Indicators" on page 228.
- 5** External Input Device Connector
- 6** PCMCIA Slot
- 7** PCMCIA Release Lever
- 8** Keyboard
- 9** LCD and Keyboard Latch
- 10** TrackPoint II
- 11** Click Button
- 12** Diskette-Eject Button
- 13** Diskette Drive
- 14** Fn Key

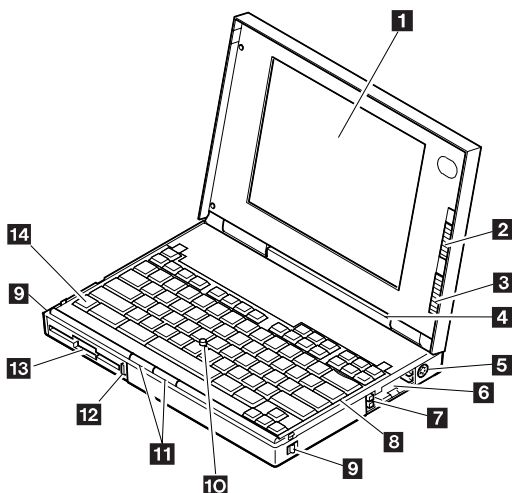

System Front View - (750P, 360P, 360PE)

- 1** Convertible LCD
- 2** Contrast Control
- 3** Brightness Control
- 4** Status Indicator
- 5** External Input Device Connector
- 6** PCMCIA Slot
- 7** PCMCIA Release Lever
- 8** Keyboard
- 9** LCD and Keyboard Latch
- 10** Hard Disk Drive Compartment
- 11** Battery Compartment
- 12** Click Buttons
- 13** Diskette-Eject Button
- 14** Diskette Drive
- 15** Fn Key
- 16** TrackPoint II
- 17** Stylus Pen

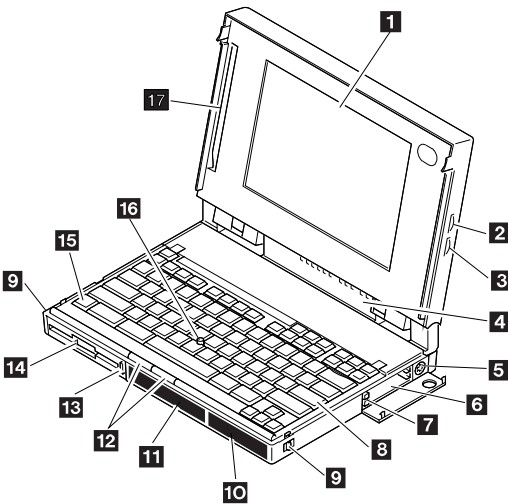

System Rear View - All Models

- 1** Diskette Drive Cover
- 2** Power Switch
- 3** Microphone/Line-In Jack
- 4** Headphone Jack

Note: Not all models have jacks **3** and **4**.

- 5** Power Jack
- 6** Serial Connector
- 7** Parallel Connector
- 8** External Display Connector
- 9** Reset Pushbutton
- 10** System Expansion Connector

Note: Model 355x does not have this connector.

A multimedia portable expansion unit, port replicator, or port replicator with PCMCIA can be connected to this interface to support the following features.

- 16-bit AT-bus interface
- Serial port
- Parallel port
- Keyboard and mouse
- HDD connection
- LED control signals
- Visual signals
- Audio signals
- FDD signals
- PCMCIA signals
- Power controls
- Power line

- 11** Connector Door
- 12** Rear Door

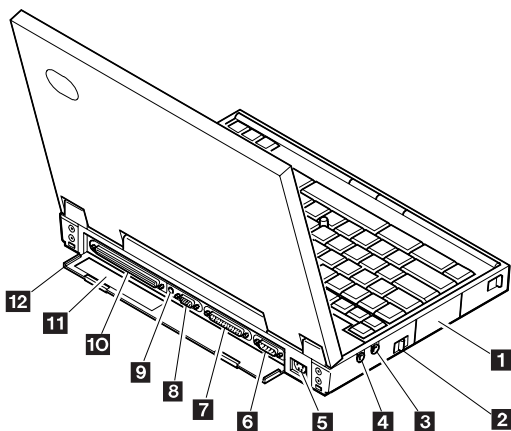

System Board (Top View)

- 1** Power Switch
- 2** Modem Card Connector (355x, 360x)
- 3** Serial Connector
- 4** Audio Card Connector
- 5** Speaker Connector (370C only)
- 6** Parallel Connector
- 7** Interposer Card Connector
- 8** External Display Connector
- 9** Reset Pushbutton
- 10** System Expansion Connector

Note: Model 355x does not have this connector.

- 11** External Input Device Connector
- 12** Hard Disk Drive Connector
- 13** PCMCIA Slot
- 14** DC/DC Card Connector
- 15** IC DRAM Card Connector
- 16** Diskette Drive Connector

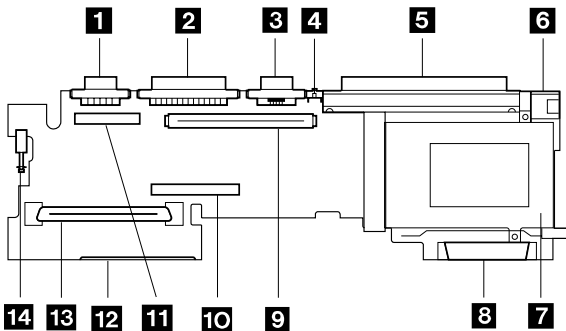

System Board (Bottom View)

- 1** Power-On Password Connector
- 2** Backup Battery Connector
- 3** Standby Battery Connector
- 4** IC DRAM Card Connector
- 5** Processor Card Connector (750Ce, 755C, 755Cs)

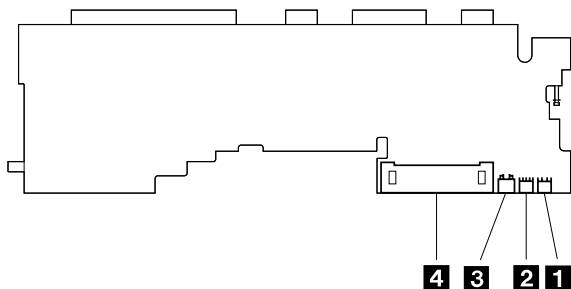

Processor Card (370C, 750Ce, 755C, 755Cs)

- 1 System Board Connector

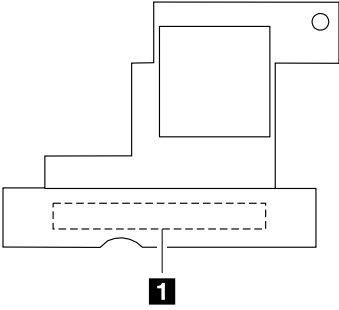

DC/DC Card - Top View

- 1 External Power Jack
- 2 Battery Pack Terminal

Models 355x, 360x

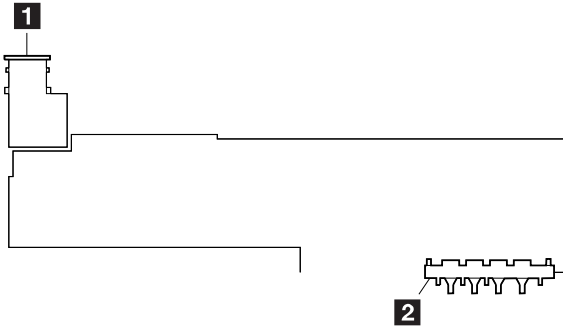

Models 370C, 750x, 755x

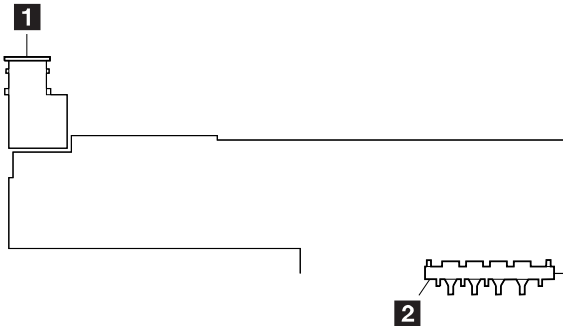

Interposer Card - All Models (Front View)

- 1** LCD Connector, Color
- 2** LCD Connector, Pen
- 3** LCD Connector, Monochrome and Color
- 4** LCD Power Connector, Color
- 5** Status Indicator Connector
- 6** Keyboard TrackPoint II Connector
- 7** Keyboard Signal Connector
- 8** Keyboard Signal Connector
- 9** LCD Open Detect Switch

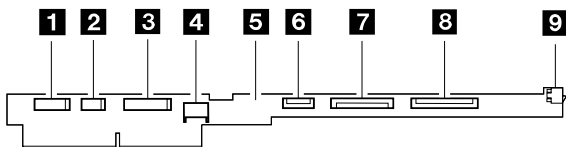

Parts Listing

Models 350x, 360x

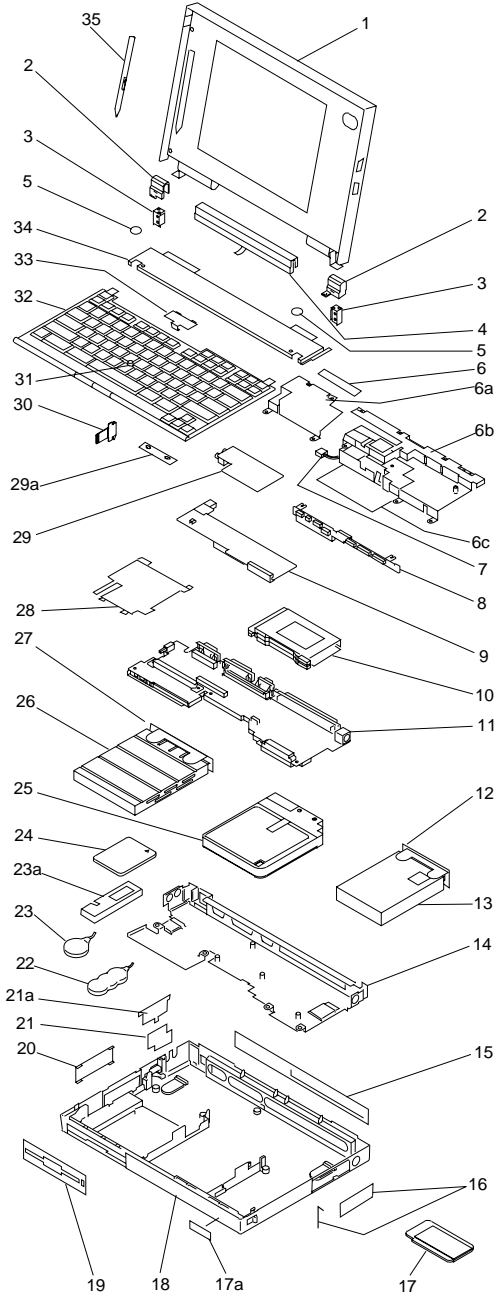

System Unit (355x, 360x)

Index

1	LCD Assembly (355, 360)	84G2265
	LCD Assembly (355C, 360C, 360CE)	84G5719
	LCD Assembly (355Cs, 360Cs, 360CSE)	84G2264
	LCD Assembly (360P)	84G5721
	LCD Assembly (360PE)	85G9678
2	Hinge Cover (355, 360)	84G2303
	Hinge Cover (355C, 360C, 360CE)	84G5703
	Hinge Cover (355Cs, 360Cs, 360CSE)	84G2258
	Hinge Cover (360P, 360PE)	84G5704
3	Hinge Bracket, Right, Left	66G5057
4	Status Indicator Assembly (355)	84G2299
	Status Indicator Assembly (355C)	84G5722
	Status Indicator Assembly (355Cs)	84G2298
	Status Indicator Assembly (360)	84G2297
	Status Indicator Assembly (360C)	84G5718
	Status Indicator Assembly (360Cs)	84G2251
	Status Indicator Assembly (360CE)	85G2408
	Status Indicator Assembly (360CSE)	85G2407
	Status Indicator Assembly (360P)	84G5720
	Status Indicator Assembly (360PE)	85G9646
5	Screw Cover	66G5046
6	Small Shield (355x, 360, 360C, 360Cs, 360P)	84G5860
	Small Shield (360CE, 360CSE, 360PE)	84G5639
6a	Speaker Shield Assembly	84G2255
6b	Insulator	84G5705
7	Speaker (Includes speaker holder)	66G3754
8	Interposer Card (355x, 360, 360C, 360Cs, 360P)	85G0959
	Interposer Card (360PE)	85G9672
	Interposer Card (360CE, 360CSE)	85G2403
9	DC/DC Card	84G2253
10	PCMCIA Slot Assembly (1-slots, 355x)	84G2273
	PCMCIA Slot Assembly (2-slots, 360x)	66G5121
11	System Board (355x)	84G2300
	System Board (360, 360C, 360Cs, 360P)	84G2252
	System Board (360CE, 360CSE, 360PE)	85G2409
12	HDD Removal Strap	66G5122
13	Hard Disk Drive (Includes strap, index 12)	
	125MB	84G2271
	170MB	66G5066
	250MB	84G2272
	340MB	66G5068
	540MB	84G4319
	810MB	85G0961
14	Lower Shield (355x)	84G2301
	Lower Shield (360x)	84G2256
15	Rear Connector Cover (355x)	84G2304
	Rear Connector Cover (360x)	84G2259
16	PCMCIA Cover	84G2262
	(Includes bezels and security plate)	
17	PCMCIA Device	
17a	Name Labels	66G9228
18	Base Cover Assemblies include coil spring, insulator, foot, power switch knob, holder, latch buttons	
	Base Cover Assembly (355)	84G2276
	Base Cover Assembly (355C)	84G5717
	Base Cover Assembly (355Cs)	84G2275

Index

	Base Cover Assembly (360)	84G2274
	For Benelux	84G5707
	For Japan	84G5708
	Base Cover Assembly (360C)	84G5711
	For Benelux	84G5712
	For Japan	84G5708
	Base Cover Assembly (360Cs)	84G2250
	For Benelux	84G5709
	For Japan	84G5708
	Base Cover Assembly (360CE, 360CSE)	85G2404
	For Benelux	85G2405
	For Japan	85G2406
	Base Cover Assembly (360P)	84G5714
	For Benelux	84G5715
	For Japan	84G5708
	Base Cover Assembly (360PE)	85G9676
	For Benelux	85G9681
	For Japan	85G2406
19	Bezel, Diskette Drive	84G2260
20	Cover, Option Bay	84G2261
21	Bracket, Audio Card (option)	84G2306
	Bracket, Internal Modem	84G2291
	(Built-in for 355x, option for 360x)	
21a	Bezel, Audio Card (option)	84G2307
	Bezel, Blank	84G2295
	Bezel, Internal Modem	84G2296
	(Built-in for 355x, option for 360x)	
22	Standby Battery	66G3755
	For Belgium, Dutch	66G3761
	For Switzerland	66G3758
23	Backup Battery	84G2263
24	Attachment holder	84G2294
25	IC DRAM Card (See options)	
26	Battery Pack (Nickel Metal Hydride)	84G2144
27	Diskette Drive (3-mode)	84G2269
	(Includes strap, reference 28)	
28	Diskette Drive Removal Strap	66G5123
29	Base Plate	84G2293
30	Bracket Shield	84G5861
31	Internal Modem Card (See options)	
	Audio Card (option)	66G5037
32	Fax/Audio Spacer (360x)	84G5862
33	Keyboard Lock	66G0031
34	TrackPoint II Cap	66G6444
35	See Keyboard List	
36	Leaf Spring Plate	66G0041
37	Upper Cover (355Cs, 360Cs, 360CSE)	84G2257
	Upper Cover (Other models)	84G2302
38	Stylus Pen (360P, 360PE)	66G6695
	EMI Spring Plate	85G0948
	PCMCIA Security Plate	85G8625
	AC Adapter (100 - 240 V ac, 40W, 3-pin)	49G2196
	For Japan (2-pin)	49G2197
	AC Adapter (100 - 125 V ac, 30W, 3-pin)	84G2277
	(This adapter is for U.S. only.)	
	AC Adapter (35 W, 3-pin)	85G4952
	For Japan (2-pin)	85G6669
	AC Adapter (30 W, U.S. only)	84G2277
	DC Plug	85G6664
	Foot (right or left)	84G4326

Keyboard

Arabic	84G5909
Belgium	84G5907
Canadian French	84G5915
Danish	84G5906
Dutch	84G5904
Finnish, Swedish	84G5903
French	84G5900
German (Black)	84G5898
Greek	84G5913
Hebrew	84G5910
Italian	84G5902
Japanese	84G5916
Latin American	84G5914
Norwegian	84G5908
Portuguese	84G5911
Spanish	84G5905
Swiss/French	84G5901
Swiss/German	84G5899
Turkish	84G5912
U.K. English	84G5897
U.S. English	84G5896
Russian	84G8348

Model 370C

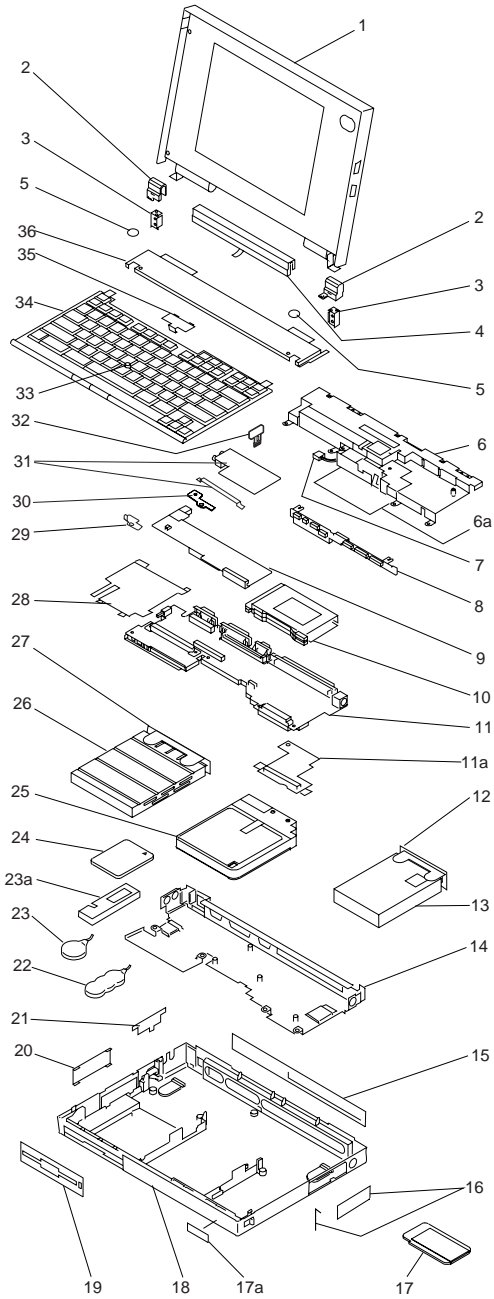

System Unit (370C)

Index

1	LCD Assembly	29H7543
2	Hinge Cover	66G5047
3	Hinge Bracket, Right, Left	66G5057
4	Status Indicator Assembly	29H6688
5	Screw Cover	66G5046
6	Speaker Shield Assembly	84G4290
6a	Insulator	84G4357
7	Speaker (Includes speaker holder)	66G3754
8	Interposer Card	66G9242
9	DC/DC Card	84G4329
10	PCMCIA Slot Assembly	66G5121
11	System Board (Does <i>not</i> include PCMCIA slot assembly, index 10, lower shield, index 14, or processor card, index 11a)	29H6690
11a	Processor Card (25/75 MHz) (Includes hex screws, nut, and screw cover)	84G4288
12	HDD Removal Strap	66G5122
13	Hard Disk Drive (includes strap, index 12) 340MB 540MB 810MB	66G5068 84G4319 85G0961
14	Lower Shield	84G4291
15	Rear Connector Cover	66G5050
16	PCMCIA Cover (Includes bezels and security plate)	66G5053
17	PCMCIA Device	
17a	Name Label	66G9228
18	Base Cover Assembly includes coil spring, insulator, foot, power switch knob, holder, latch buttons Base Cover Assembly For Benelux For Japan	29H7544 29H7547 29H7545
19	Bezel, Diskette Drive	66G5051
20	Cover, Option Bay	66G5052
21	Blank Audio Bezel Audio Bezel Supported in Japan and European countries	29H7546 84G4292
22	Standby Battery For Belgium, Dutch For Switzerland	66G3755 66G3761 66G3758
23	Backup Battery	84G2263
23a	Attachment Holder	84G2294
24	IC DRAM Card (See options)	
25	Battery Pack (Nickel Metal Hydride)	29H6687
26	Diskette Drive (3-mode) (Includes strap, reference 27)	84G2269
27	Diskette Drive Removal Strap	66G5123
28	Base Plate	84G2293
29	Hinge Cover Bracket	29H8762
30	Bracket Shield	84G5861
31	Fax/Audio Spacer Audio Card Supported in Japan and European countries	84G5862 66G5037
32	Keyboard Lock	66G0031
33	TrackPoint III Cap	84G6536
34	Keyboard Assembly (See keyboard list)	
35	Leaf Spring Plate	66G0041

Index

36	Upper Cover	84G2257
	PCMCIA Security Plate	85G8625
	EMI Spring Plate	85G0948
	DC Plug	85G6664

Keyboard

Arabic	66G0163
Belgian	66G0161
Canadian French	66G0169
Danish	66G0160
Dutch	66G0158
Finnish	66G0157
French	66G0154
German (Black)	66G6402
Greek	66G0167
Hebrew	66G0164
Italian	66G0156
Japanese	66G0171
Latin American	66G0168
Norwegian	66G0162
Portuguese	66G0165
Spanish	66G0159
Swedish	66G0157
Swiss/French	66G0155
Swiss/German	66G0153
Turkish	66G0166
U.K. English	66G0151
U.S. English	66G0150
Russian	85G7443

Model 750x

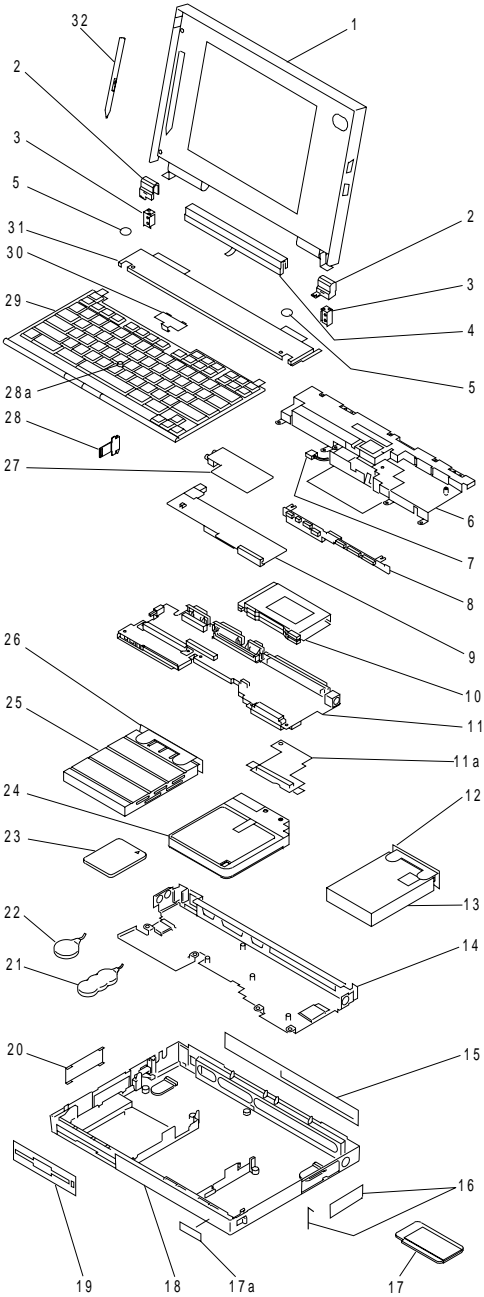

System Unit (750x)

Index

1	LCD Assembly (750) ⁴	66G3710
	For Germany (Gray) ⁴	66G3711
	LCD Assembly (750C, 750Ce) ⁴	66G5058
	For Germany (Gray) ⁴	66G5083
	LCD Assembly (750P) ⁴	66G5059
	For Germany (Gray) ⁴	66G5084
	LCD Assembly (750Cs)	66G6210
	For Germany (Gray)	66G6211
2	Hinge Cover (750)	66G5048
	For Germany (Gray)	66G5077
	Hinge Cover (750C, 750Cs, 750Ce)	66G5047
	For Germany (Gray)	66G5076
	Hinge Cover (750P)	66G5049
	For Germany (Gray)	66G5078
3	Hinge Bracket, Right, Left	66G5057
4	Status Indicator Assembly (750)	66G5034
	For Germany (Gray)	66G5072
	Status Indicator Assembly (750C)	66G5033
	For Germany (Gray)	66G5071
	Status Indicator Assembly (750P)	66G5035
	For Germany (Gray)	66G5073
	Status Indicator Assembly (750Cs)	66G6321
	For Germany (Gray)	66G6324
	Status Indicator Assembly (750Ce)	66G9222
	For Germany (Gray)	66G9223
5	Screw Cover	66G5046
	For Germany (Gray)	66G5075
6	Speaker Shield Assembly	66G5041
7	Speaker (Includes speaker holder)	66G3754
8	Interposer Card (750, 750C, 750Cs, 750P)	66G5044
	Interposer Card (750Ce)	66G9242
9	DC/DC Card (750, 750C, 750Cs, 750P)	66G5038
	DC/DC Card (750Ce)	66G9226
	DC/DC Card (750Ce, 25/75 MHz)	66G9267
10	PCMCIA Slot Assembly	66G5121
11	System Board Assembly (750, 750C, 750P) ⁴	66G5036
	(Includes PCMCIA slot assembly, index 10, and lower shield, index 14)	
	System Board Assembly (750Cs) ⁴	66G6209
	For Germany (Includes PCMCIA slot assembly, index 10, and lower shield, index 14)	66G6211
	System Board (750Ce) ⁴	66G9224
	(Does <i>not</i> include PCMCIA slot assembly, index 10, lower shield, index 14, or processor card, index 11a)	
11a	Processor Card (750Ce)	66G9225
	Processor Card (750Ce, 25/75 MHz) (Includes hex head screws, nut, and screw cover)	84G4288
12	HDD Removal Strap	66G5122

⁴ See "Digitizer Adjustment" on page 205.

Index

13	Hard Disk Drive (Includes strap, index 12)	
	170MB	66G5066
	For Germany (Gray)	66G5085
	340MB	66G5068
	For Germany (Gray)	66G5087
14	Lower Shield (750, 750C, 750Cs, 750P)	66G5043
	Lower Shield (750Ce)	66G9227
15	Rear Connector Cover	66G5050
	For Germany (Gray)	66G5079
16	PCMCIA Cover	66G5053
	(Includes bezels and security plate)	
	For Germany (Gray)	66G5082
17	PCMCIA Device	
17a	Name Label (750, 750C, 750Cs, 750P)	66G7865
	For Germany (Gray)	66G7866
	Name Label (750Ce)	66G9228
	For Germany (Gray)	66G9229
18	Base Cover Assemblies include coil spring, insulator, foot, power switch knob, holder, and latch buttons	
	Base Cover Assembly (750)	66G5125
	For Netherlands, Belgium	66G5131
	For Germany (Gray)	66G5128
	For Japan	66G4590
	Base Cover Assembly (750C)	66G5126
	For Netherlands, Belgium	66G5132
	For Germany (Gray)	66G5129
	For Japan	66G4590
	Base Cover Assembly (750Ce)	66G9217
	For Netherlands, Belgium	66G9219
	For Germany (Gray)	66G9218
	For Japan	66G9220
	Base Cover Assembly (750Cs)	66G4591
	For Netherlands, Belgium	66G4593
	For Germany (Gray)	66G4592
	For Japan	66G4590
	Base Cover Assembly (750P)	66G5127
	For Netherlands, Belgium	66G5133
	For Germany (Gray)	66G5130
	For Japan	66G4590
19	Bezel, Diskette Drive	66G5051
	For Germany (Gray)	66G5080
20	Cover, Option Bay	66G5052
	For Germany (Gray)	66G5081
21	Standby Battery	66G3755
	For Netherlands, Belgium	66G3761
	For Switzerland	66G3758
22	Backup Battery	66G3764
23	IC DRAM Card (See options)	
24	Battery Pack (Nickel Metal Hydride)	66G2820
	For Netherlands, Belgium	66G2822
	For Switzerland	66G2821
	For Denmark, Sweden, Finland, Norway	66G5063
25	Diskette Drive	66G5060
	(Includes strap, reference 26)	
26	Diskette Drive Removal Strap	66G5123
27	Audio Card	66G5037
28	Keyboard Lock	66G0031
28a	TrackPoint II Cap	66G6444

Index

29	See Keyboard List	
30	Leaf Spring Plate	66G0041
31	Upper Cover (750)	66G5045
	For Germany (Gray)	66G5074
	Upper Cover (750C, 750Cs, 750Ce)	66G5094
	For Germany (Gray)	66G5095
	Upper Cover (750P)	66G6771
	For Germany (Gray)	66G6772
32	Stylus Pen (750P) ⁵	66G6695
	For Germany (Gray) ⁵	66G6696

Keyboard

Arabic	66G0163
Belgian	66G0161
Canadian French	66G0169
Danish	66G0160
Dutch	66G0158
Finnish	66G0157
French	66G0154
German (Black)	66G6402
German (Gray)	66G0152
Greek	66G0167
Hebrew	66G0164
Icelandic	66G0170
Italian	66G0156
Japanese	66G0171
Latin American	66G0168
Norwegian	66G0162
Portuguese	66G0165
Spanish	66G0159
Swedish	66G0157
Swiss/French	66G0155
Swiss/German	66G0153
Turkish	66G0166
U.K. English	66G0151
U.S. English	66G0150

⁵ See "Digitizer Adjustment" on page 205.

Models 755C and 755Cs

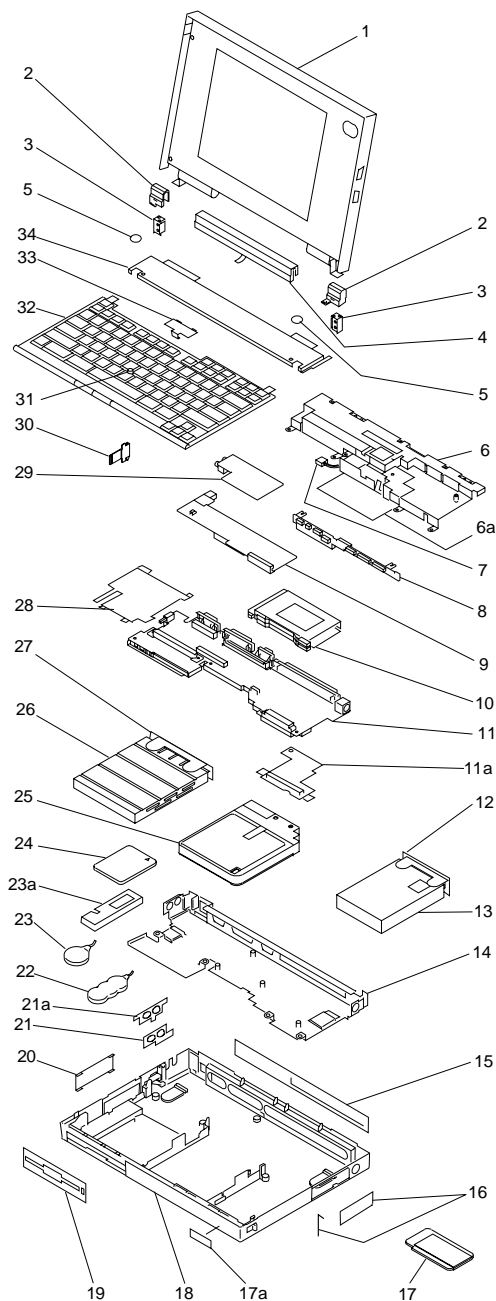

System Unit (755C, 755Cs)

Index

1	LCD Assembly (755C)	66G5058
	For Japan	84G4316
	LCD Assembly (755C)	84G4337
	(This LCD does not have a contrast control.)	84G4317
	LCD Assembly (755Cs)	
2	Hinge Cover	66G5047
3	Hinge Bracket, Right, Left	66G5057
4	Status Indicator Assembly (755C)	84G4293
	Status Indicator Assembly (755Cs)	84G4355
5	Screw Cover	66G5046
6	Speaker Shield Assembly	84G4290
6a	Insulator	84G5705
7	Speaker (Includes speaker holder)	66G3754
8	Interposer Card	66G9242
9	DC/DC Card	84G4329
10	PCMCIA Slot Assembly	66G5121
11	System Boards	
	(The following do <i>not</i> include PCMCIA slot assembly, index 10, lower shield, index 14, or processor card, index 11a)	
	System Board	84G4287
	(For LCD with a contrast control)	
	System Board	84G5632
	(For LCD without a contrast control)	
11a	Processor Card (25/50 MHz)	59G4056
	Processor Card (25/75 MHz)	84G4288
	(Includes hex head screws, nut, and screw cover)	
12	HDD Removal Strap	66G5122
13	Hard Disk Drive (Includes strap, index 12)	
	170MB	66G5066
	340MB	66G5068
	540MB	84G4319
	810MB	85G0961
14	Lower Shield	84G4291
15	Rear Connector Cover	66G5050
16	PCMCIA Cover	66G5053
	(Includes bezels and security plate)	
17	PCMCIA Device	
17a	Name Label	66G9228
18	Base Cover Assemblies include coil spring, insulator, foot, power switch knob, holder, latch buttons	
	Base Cover Assembly	84G4281
	For Benelux	84G4282
	For Japan	84G4283
19	Bezel, Diskette Drive	66G5051
20	Cover, Option Bay	66G5052
21	Bezel, Audio Card	84G4292
	(Includes bracket, index 21a)	
22	Standby Battery	66G3755
	For Belgium, Dutch	66G3761
	For Switzerland	66G3758
23	Backup Battery	84G2263

⁶ See "Digitizer Adjustment" on page 205.

Index

23a	Attachment Holder	84G2294
24	IC DRAM Card (See Options)	
25	Battery Pack (Nickel Metal Hydride)	66G2820
	For Belgium, Dutch	66G2822
	For Switzerland	66G2821
	For Danish, Sweden, Finland, Norway	66G5063
26	Diskette Drive (4-mode)	66G5060
	(Includes strap, index 27)	
	Diskette Drive (3-mode)	84G2269
	(Includes strap, index 27)	
27	Diskette Drive Removal Strap	66G5123
28	Base Plate	84G2293
29	Audio Card	84G4289
30	Keyboard Lock	66G0031
31	TrackPoint II Cap	66G6444
32	Keyboard Assembly (See keyboard list)	
33	Leaf Spring Plate	66G0041
34	Upper Cover	84G4318

Keyboard

Arabic	66G0163
Belgian	66G0161
Canadian French	66G0169
Danish	66G0160
Dutch	66G0158
Finnish	66G0157
French	66G0154
German (Black)	66G6402
Greek	66G0167
Hebrew	66G0164
Italian	66G0156
Japanese	66G0171
Latin American	66G0168
Norwegian	66G0162
Portuguese	66G0165
Spanish	66G0159
Swedish	66G0157
Swiss/French	66G0155
Swiss/German	66G0153
Turkish	66G0166
U.K. English	66G0151
U.S. English	66G0150

Common/Option Parts List

Miscellaneous Parts

AC Adapter (35 W, 3-pin)	85G1952
For Japan (2-pin)	85G6669
AC Adapter (40 W, 3-pin)	49G2196
For Japan (2-pin)	49G2197
AC Adapter (40 W, 3-pin, U.S. only) (not for 370C)	84G4320
Foot (right or left)	84G4326
Miscellaneous Parts Kit (Includes DC-in holder, spacer, warning label)	
For Models 750x	66G5039
For Models 355x, 360x, 370C, 755C, 755Cs	84G2254
PC Card Locking Bar	85G8625
Screw Kit (Includes: 10-2.5 x 4 mm; 10-2.5 x 6 mm 10-2.5 x 8 mm, Flat head 10-2.5 x 8 mm; 10-2.5 x 16 mm 10-hex stud I/O; 10-hex stud bus 2-washer for hex stud bus)	66G5124
IC DRAM CARD Eject Tape	53G9318

Options

Notes:

1. When you replace the AC adapter or the Quick Charger with a new one, use the one for the country you are in even if the system is from different country.
2. The warranty for the system unit is not applied to all options.

Audio Cable	66G5180
Car Battery Adapter (48G9203 label sealed)	49G1148
Car Battery Adapter (66G9984 label sealed)	84G4359
Diskette Drive Attachment Unit	66G5069
IC DRAM CARD 2MB	07G1414
IC DRAM CARD 4MB	07G1415
IC DRAM CARD 8MB	07G1416
IC DRAM CARD 16MB	66G0094
Microphone	66G7871
PS/2 Miniature Mouse	95F5723
Port Replicator	66G3575
Port Replicator with PCMCIA	66G3574
Quick Charger (3-pin)	66G2815
For Japan (2-pin)	66G2816

Model Unique Options

Models 355x, 360x, 370C

Basic IC DRAM CARD (no parity)	
8MB	84G5725
4MB	84G5724
16MB	84G5726
Internal Modem Card (U.S./Canada/Latin America)	84G5917
Telephone Cable (U.S./Canada/Latin America)	84G8254
Telephone Wall Plug	85G2367

Model 370C

Audio Card	66G5037
Basic IC DRAM CARD (no parity)	
8MB	84G5725
4MB	84G5724
16MB	84G5726
Diskette Drive (4-mode) Supported in U.S. only.	66G5060

Models 750x

AC Adapter (35 W, 3-pin) For Japan (2-pin)	85G1952 85G6669
AC Adapter (40 W, 3-pin, U.S. only)	84G4320
AC Adapter (40 W, 3-pin) For Japan (2-pin)	49G2196 49G2197

Models 755C, 755Cs

DIMM 4MB	84G4323
DIMM 8MB	84G6545
DIMM 16MB	84G4324
DIMM Adapter Card	84G4322
Diskette Drive (4-mode) Supported in U.S. only.	66G5060

Numeric Keypad

Belgian	95F5741
Canadian French	95F5466
Danish	95F5467
Dutch	95F5467
French	95F6313
German	95F6314
Greek	95F5467
Hebrew	95F5741
Icelandic	95F5467
Italian	95F6316
Japanese	79F6401
Norwegian	95F5467
Spanish	95F6315
Swedish/Finnish	95F5468
Swiss/French	95F5711
Swiss/German	95F5715
Turkish	95F5467
U.K. English	95F5741
U.S. English	95F5741

Accessories

Keyboard/Mouse Cable	54G0444
----------------------	---------

Tools

Tri-Connector Wrap Plug	72X8546
PC Test Card	35G4703
Screwdriver Kit	95F3598
ThinkPad 750Ce	82G3891
Hardware Maintenance Diskette (This diskette is common for all models of ThinkPad.)	

Power Cords

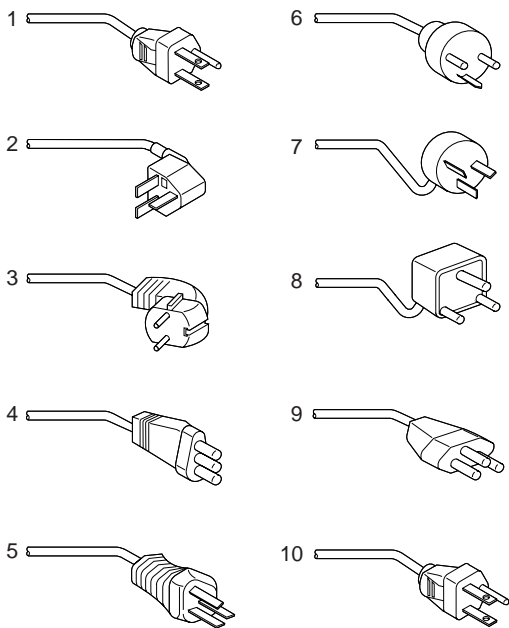

Warning: Use the power cord certified for your country.

		30/40W	35W
1	Colombia, U.S., Venezuela	13F9959	25H2207
	Japan, 2-pin	6454377	85G6665
	Japan, 3-pin	65F0031	
2	Hong Kong, Singapore, U.K.	14F0033	25H2215
3	France, Germany, Spain	13F9979	25H2209
4	Italy	14F0069	25H2223
5	Australia, New Zealand	13F9940	25H2205
6	Denmark	13F9997	25H2211
7	Israel	14F0087	25H2225
8	Bangladesh, Pakistan, Sri Lanka, South Africa	14F0015	25H2213
9	Switzerland	14F0051	25H2221
10	Thailand	1838574	25H2219

Notes:

- Models 370C, 755C, and 755Cs do not support the 30W AC adapter.
- The 30/40W cord is 6 foot long; the 35W cord is 6 inches.

ThinkPad 755CD, 755CDV (9545)

General Checkout	317
Memory Checkout	317
System Board and Processor Card Checkout	319
Keyboard/Auxiliary Input Device Checkout	320
TrackPoint III Checkout	320
Game Port Checkout	321
Diskette Drive Test	321
Power Systems Checkout	322
Power Management Features	328
Symptom-to-FRU Index	331
Numeric Error Codes	331
FRU Codes	334
Beep Symptoms	335
No Beep Symptoms	336
LCD Related Symptoms	336
Model 755CDV Symptoms	337
Keyboard/TrackPoint III Related Symptoms	339
Indicator Related Symptoms	339
Power Related Symptoms	339
Function/Audio Related Symptoms	340
Peripheral Device Related Symptoms	341
Other Symptoms	341
Infrared Related Symptoms	342
Intermittent Problems	342
Undetermined Problems	343
Related Service Procedures	344
Status Indicators	344
How to Run the Diagnostics	345
Error Log	346
Reset Pushbutton	346
Checking the Installed Devices List	346
Password Combinations (POP, HDP, PAP)	347
How to Run the Low Level Format	347
PC Test Card LED	347
Fn Key Combinations	348
How To Run the Keyboard Diagnostics	348
Product Overview	349
FRU Removals and Replacements	350
2010 Rear Connector Door	351
2015 Foot	351
2020 Battery Pack	352
2030 CD-ROM/Diskette Drive	353
2040 Hard Disk Drive	354
2050 IC DRAM Card or DIMM Adapter	355
2060 Keyboard Spacer	358
2080 Keyboard Unit	359
2090 Status Indicator	362
2100 Standby Battery and Front IR	363
2110 Backup Battery	364
2115 Logic Assembly	365
2120 Shield Assembly	367

2125	Video Card or Rear IR	368
2130	DC/DC Card	369
2140	DSP Card	370
2150	Interposer Card	371
2160	System Board Assembly	372
2170	PCMCIA Slot Assembly	373
2180	Processor Card	375
2190	LCD Assembly	377
2195	LCD Rear Cover (755CDV only)	378
2200	Lower Shield Assembly	379
2210	Memory Card	380
Locations	381
Front View	381
Rear View	382
Parts Listing	383
Common/Option Parts List	386

General Checkout

Use the following procedure as a guide for computer problems. The diagnostic tests are intended to test only IBM products. Non-IBM products, prototype cards, or modified options can give false errors and invalid system responses.

1. Obtain the failing symptoms in as much detail as possible.
2. Verify the symptoms by attempting to recreate the failure by running the diagnostic test or by repeating the same operation.

Note: To run the diagnostics, refer to “How to Run the Diagnostics” on page 345.

3. Use the following table with the verified symptom to determine which page to go to. Search the symptoms column and find the description that best matches your symptom; then go to the page shown in the “Go to” column.

Symptom	Go to
Power failure. (The power indicator does not go on or stay on.)	“Power Systems Checkout” on page 322.
POST does not complete. No beeps or error codes are indicated.	“Symptom-to-FRU Index” on page 331, and then use the No Beep Symptoms table.
POST beeps, but no error codes are displayed.	“Symptom-to-FRU Index” on page 331, and then use the Beep Symptoms table.
POST detected an error and displayed numeric error codes.	“Symptom-to-FRU Index” on page 331, and then use the Numeric Error Codes table.
The diagnostic test detected an error and displayed an FRU code.	“FRU Codes” on page 334.
The configuration is not the same as the installed devices.	“Checking the Installed Devices List” on page 346.
Other symptoms (such as LCD display problems).	“Symptom-to-FRU Index” on page 331, and then use the other symptom table.
Symptoms cannot be recreated. (Intermittent problems.)	Use the customer reported symptoms and go to “Symptom-to-FRU Index” on page 331.

Memory Checkout

One of two types of memory cards can be used, IC DRAM card or DIMM card. See the following table for the total memory size available when they are installed.

IC DRAM	Displayed Value
0MB	7808KB
2MB	9856KB
4MB	11904KB
8MB	16000KB
16MB	24192KB

DIMM	Displayed Value
0MB	7808KB
4MB	11904KB
8MB	16000KB
12MB	20096KB
16MB	24192KB
20MB	28288KB
24MB	32384KB
32MB	40576KB

Memory errors might stop system operations, show error messages on the screen, or hang the system. The computer detects memory parity errors but does not correct them.

Use the following procedure to isolate memory problems.

1. Check whether or not the memory card use parity or non-parity.

Note: Installing a non-parity memory card causes parity errors when parity checking is enabled. If the non-parity memory card is installed, disable the parity check through the Easy-Setup configuration screen.
2. Make sure that the memory card is fully seated in the connector. A loose connection can cause an error.
3. Power-off the computer and remove the IC DRAM card, or DIMM card from its slot (if installed).
4. Press and hold the F1 key; then power-on the computer. Hold the F1 key down until the Easy-Setup screen appears.
5. Select **Test** and press enter.
6. Select **Memory** and press enter to run the memory test on base memory. If an error appears, replace the memory card.
7. Power-off the computer and reinstall the IC DRAM card or DIMM card; then power-on the computer. Verify the memory size; then test the memory. If an error appears, replace the IC DRAM card or the DIMM card.

If memory problems occur intermittently, use the loop option to repeat the test. When the test detects an error,

an error log is printed on the printer connected to the parallel port. See "Error Log" on page 346 for more information.

System Programs in Flash Memory: System setup programs and diagnostic tests are stored in flash memory.

Flash Memory Update: A flash memory update is required for the following conditions:

- New versions of system programs.
- New feature or options are added.

When Updating Flash Memory

Do not power-off the computer, disconnect the Vac power, or remove the battery during the Flash update. The system board will have to be replaced if the update is interrupted.

Updating Flash memory also resets all of the customer's configuration settings to the default values.

To update the Flash memory, perform the following steps:

1. Get the appropriate diskette which contains the update.
2. Insert the **System Program Service Diskette** into drive A and power-on the computer.
3. Select **Update system programs** from the menu.

System Board and Processor Card Checkout

The processing functions are performed by both the system board and the processor card. Processor problems can be caused by either FRU. However, the processor card generally has a lower probability of failure. When a numeric code calls the system board or the processor card as a FRU, or the processor card is called by a diagnostic test by showing FRU code 11, use the following procedure to isolate the problem.

1. Run the system board test to verify the symptom. This test verifies both the system board and the processor card. If no error is detected, return to "General Checkout" on page 317.
2. If FRU code 10 appears, replace the system board but do not replace the processor card. Transfer the processor card from the old system board to the new system board.
3. If FRU code 11 appears, reseal the processor card.
4. Rerun the test to verify the fix.
5. If FRU code 11 remains, replace the processor card.

If above procedure does not correct the problem, go to "Undetermined Problems" on page 343.

Keyboard/Auxiliary Input Device Checkout

Remove the external keyboard if the internal keyboard is to be tested.

If the internal keyboard does not work or an unexpected character appears, make sure that the three flexible cables extending from the keyboard are correctly seated in the connectors on the interposer card.

If the keyboard cable connection is correct, run the **Keyboard Test** by doing the following:

1. Go to diagnostic menu screen by pressing **Ctrl+A** in the Easy-Setup screen.
2. Press **Ctrl+K**; a layout of the keyboard appears on the screen.
3. Check that when each key is pressed, the key position on the keyboard layout on the screen changes to a black square.

Note: When a Fn key is pressed, a black square briefly appears.

If the tests detect a keyboard problem, do the following one at a time to correct the problem. Do not replace a non-defective FRU.

- Reseat the three cables.
- Replace the keyboard.
- Replace the Video Card Assembly.
- Replace the system board.

The following auxiliary input devices are supported for this computer.

- Numeric keypad
- Mouse (PS/2 compatible)
- External keyboard (with keyboard/mouse cable)

If any of the above devices do not work, reseat the cable connector and repeat the failing operation.

If the problem does not occur again, recheck the connector.

If the problem is not corrected, replace the device, and then the system board.

TrackPoint III Checkout

If the TrackPoint III will not work, check the configuration in the Easy-Setup by selecting **Keyboard** from the **Config** menu. If the configuration of the TrackPoint III is disabled, select **Enable** to enable it.

If this does not correct the TrackPoint III problem, continue with the following.

The TrackPoint III does automatic compensations to adjust the pointer sensor. During this process, the pointer moves

on the screen automatically for a short time. This self-acting pointer movement can occur when a slight, steady pressure is applied to the TrackPoint III pointer while the computer is powered on or while the system is running, or re-adjustment is required because the temperature has exceeded its normal temperature range. This symptom does not indicate a hardware problem. No service actions are necessary if the pointer movement stops in a short period of time.

If a click button problem or pointing stick problem occurs, do the following:

1. Go to the Easy-Setup screen.
2. Select an item with the pointing stick.
3. Press either the left or right click button.
4. Verify that both buttons work correctly.

If either the pointing stick or the click button will not work, do the following actions one at a time to correct the problem. Do not replace a non-defective FRU.

- Reseat the three keyboard cables.
- Replace the keyboard.
- Replace the interposer card.
- Replace the system board.

Game Port Checkout

Do the following if a joystick problem occurs.

1. Connect the Joystick to the Game Port.
2. Go to the Easy-Setup screen.
3. Select an item with the Joystick.
4. Press any button of the Joystick.
5. Verify all buttons work correctly.

If either the Joystick or button does not work, replace the system board.

Diskette Drive Test

Do the following to isolate the problem to a controller, drive, or diskette. A scratch, write enabled, non-defective 2HD diskette is required.

Warning: Make sure that the diskette does not have more than one label attached to it. Multiple labels can cause damage to the drive or can cause the drive to fail.

Do the following to select the test device:

1. Select the advanced diagnostic mode and select **Tool**; then select the icon **FDD-1** or **FDD-2** and press the space key. A ✓ mark appears next to the selected icon. Insert the **blank** diskette when instructed.
2. Run the diskette drive test.
3. If the controller test detects an error, FRU code 10 appears. Replace the system board.

4. If the controller test runs without errors, the drive read/write tests start automatically.
5. If the drive test detects an error, FRU code 50 for FDD-1 or 51 for FDD-2 appears. If the diskette itself is known to be good, replace the drive.
6. If the drive is attached through a Port Replicator as FDD-1 or FDD-2 and the test detects errors, move the drive to the computer's diskette drive connector directly, and test it again as FDD-1.

If no errors occur at the FDD-1 position, the drive is not defective. Go to "Port Replicator Checkout" in "Common Devices Checkout" section to isolate the replicator problem.

7. If the drive is attached through an Expansion Unit, go to the service manual of the Expansion Unit to isolate the problem.
8. If the drive is attached through a Diskette Drive Attachment Unit, replace the unit.

Power Systems Checkout

To verify the symptom of the problem, power-on the computer using each of the power sources as follows.

1. Remove the battery pack, diskette drive, and hard disk drive.
2. Connect the AC Adapter and check that power is supplied.
3. Install the diskette drive, or hard disk drive one at a time and check that power is supplied from each power source.
4. Disconnect the AC Adapter, remove the hard disk and diskette drive, and install the charged battery pack; then check that power is supplied by battery pack.

If you suspect a power problem, see the appropriate power supply check listed below.

- "Checking the AC Adapter."
- "Checking Operational Charging" on page 323.
- "Checking the Battery Pack" on page 324.
- "Checking the Car-Battery Adapter" on page 326.
- "Checking the Backup Battery" on page 326.
- "Checking the Standby Battery" on page 327.
- "Port Replicator Power Overload" on page 330.

Checking the AC Adapter: You are here because the computer fails only when the AC Adapter is used.

- If the power problem occurs only when the port replicator is used, replace the replicator.
- If the power-on indicator does not turn on, check the power cord of the AC Adapter for correct continuity and installation.

- If the operational charge does not work, go to “Checking Operational Charging” on page 323.

Note: There are several types of adapters. The procedure for checking both types is the same.

1. Unplug the AC Adapter cable from the computer and measure the output voltage at the plug of the AC Adapter cable. See the following figure.

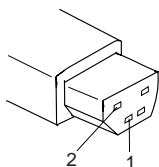

AC Adapter (40W)

Pin	Voltage (V dc)
1	+18.0 to +21.0
2	Ground

AC Adapter (35W)

Pin	Voltage (V dc)
1	+16.0 +1.0/-0.5
2	Ground

- If the voltage is correct, replace the system board. If the problem is not corrected, go to “Undetermined Problems” on page 343.
 - If the voltage is not correct, go to the next step.
2. Unplug the AC Adapter cable from the ac power outlet and wait five minutes or longer to allow the over voltage protection circuit to be fully discharged and initialized.
 3. Plug the AC Adapter cable into the ac power outlet.
 4. Measure the output voltage of the AC Adapter.
 5. If the voltage is still not correct, replace the AC Adapter.

Note: An audible noise from the AC Adapter does not always indicate a defective adapter.

Checking Operational Charging: To check operational charging, use a discharged battery pack or a battery pack that shows a yellow or orange battery status indicator when it installed in the computer.

Perform operational charging. If the battery status indicator turns orange and the battery charging indicator turns green within two minutes, replace the AC Adapter.

Checking the Battery Pack: Battery charging will not start until the Fuel-Gauge shows that less than 90% of the total power remains; with this condition the battery pack will charge to 100% of its capacity. This protects the battery pack from being over-charged or having a shortened life.

Before you do the following steps, check the following:

- The correct battery pack is used for the model.
 - The storage switch set to on (I).
1. Power-off the computer.
 2. Remove the battery pack and measure the voltage between battery terminals 1 (+) and 4 (-). See the following figure.

Ni-MH Battery Pack

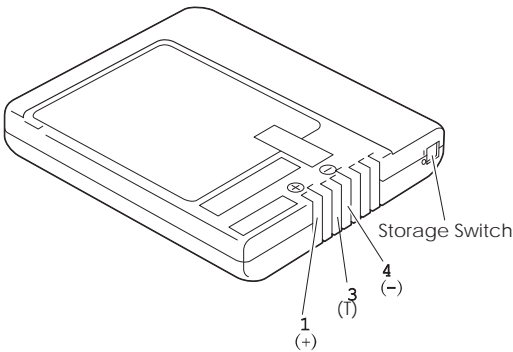

Terminal	Voltage (V dc) / Signal
1	+8.0 to +16.0
2	Send
3	Thermal
4	Ground (-)
5	NC
6	NC
7	NC

Li-ion Battery Pack

Note: Li-ion battery is optional for Model 755CDV.

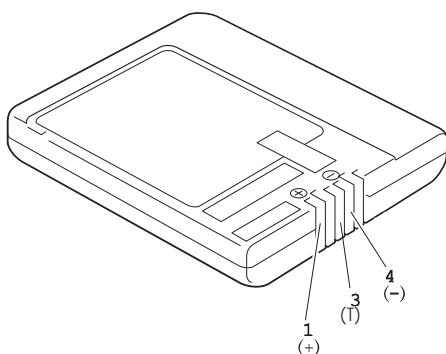

Terminal	Voltage (V dc) / Signal
1	+8.0 to +13.0
2	Send
3	Thermal
4	Ground (-)
5	R1

Note: Signal lines, not used in these steps, are used for communication between the system and the battery. The storage switch is used to control the power to the internal microprocessor of the battery. The storage switch should be set to off (0) only when the battery is going to be kept in storage for more than two months.

- If the voltage is less than +8.0 V dc, the battery pack has been discharged or is defective. Recharge the battery. If the recharging does not work, go to Step 5 to check the charging circuit.

If the voltage is still less than +8.0 V dc after the recharging, replace the battery.

- If the voltage is more than +8.0 V dc, measure the resistance between battery terminals 3 and 4. The resistance must be 4 to 30 K ohm.

If the resistance is not correct, replace the battery pack.

If the resistance is correct, replace the DC/DC card.

- To check the charging circuit, do the following. Plug in the AC Adapter with the battery pack removed, then power-on the computer.
- Measure the charging voltage between DC/DC terminals 1 (+) and 4 (-).
- If the voltage is less than +9.0 V dc, replace the DC/DC card. If the voltage is more than +9.0 V dc, the charging circuit is working correctly, replace the battery pack.

Checking the Car-Battery Adapter

Note: There are several types of adapters but the checkout procedure is the same for both of them.

1. Unplug the Car-Battery Adapter cable from the computer.
2. Plug the Car-Battery Adapter into the cigarette lighter socket.

Note: If the adapter is already plugged in, reseal it.

3. Measure the output voltage of the Car-Battery Adapter cable. See the following figure.

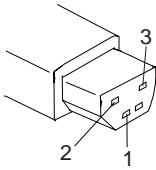

Pin	Voltage (V dc)
1	+19.0 to +21.0
2, 3	Ground

- If the voltage is correct and the power-on indicator on the Car-Battery Adapter is on all the time, the Car-Battery is working correctly. Replace the system board.

If the problem is not resolved when the system board is replaced, go to “Undetermined Problems” on page 343.

- If the voltage is outside the normal voltage range, do one of the following:
 - Try the above test procedures in a different car, if one is available.
 - Replace the Car-Battery Adapter if the computer works correctly with the AC Adapter.

Note: If the output voltage from the cigarette lighter socket of the car is less than 10.5 V dc, a continuous noise can be heard. The condition of the car battery should be checked by appropriate service personal.

Checking the Backup Battery

1. Power-off the computer and unplug the AC Adapter from the computer.
2. Open the keyboard, and remove the battery pack.
3. Remove the backup battery from the shield assembly.
4. Measure the voltage of the backup battery. See the following figure.

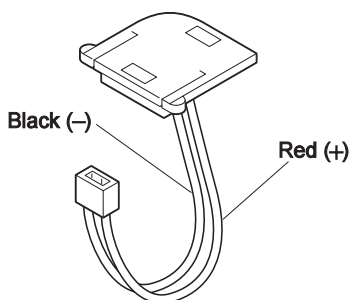

Wire	Voltage (V dc)
Red	+2.5 to +3.7
Black	Ground

- If the voltage is correct, replace the system board.
- If the voltage is not correct, the backup battery has been discharged. Replace the backup battery.
- If the backup battery discharges quickly after replacement, replace the system board.

Checking the Standby Battery

1. Power-off the computer and unplug the AC Adapter from the computer.
2. Open the keyboard, and remove the battery pack and the diskette drive.
3. Remove the standby battery. (Refer to "2100 Standby Battery and Front IR" on page 363 to remove the battery.)
4. Measure the voltage of the standby battery.
 - If the voltage between red and black is 3.5 V dc or greater, the voltage is correct. Go to Step 10 on page 328 to verify standby battery operation.
 - If the voltage is less than 3.5 V dc, go to the next step.
5. Plug the AC Adapter into the computer and power-on the computer.
6. Measure the output voltage at the connector on the system board.

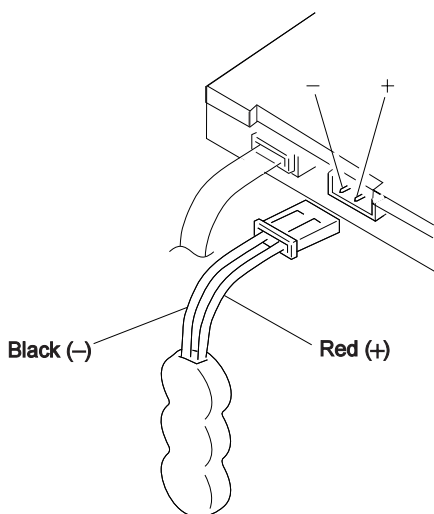

Pin	Voltage (V dc)
+	+4.0
-	Ground

- If the voltage is less than +4.0 V dc, replace the DC/DC card. If the voltage is still low, replace the system board.
 - If the voltage is more than +4.0 V dc, power-off the computer, replace the standby battery, and go to the next step.
7. Ensure that the AC Adapter is plugged into the computer; then power-on the computer.
 8. Charging of the standby battery starts. A depleted battery needs approximately 30 minutes to be recharged to the operational voltage of +3.5 V dc.
 9. Unplug the AC Adapter.
 10. Verify the standby battery function by removing and installing the battery pack during suspend mode.

Note: Removing and installing the battery pack during suspend mode should be done within one minute. The resume operation must start. If the resume operation does not work, switching of power from the battery pack to standby battery will not be correct. Replace the DC/DC card.

If replacing the DC/DC card does not resolve the problem, replace the system board.

Power Management Features

Three power management modes are provided by the computer to save power consumption and prolong battery power.

Standby Mode: When in standby mode the following occurs:

- The LCD backlight turns off.
- The hard disk motor stops.
- The CPU clock is set to the lowest speed.

Events that cause entering of standby mode:

- Standby requested by the Fn key. (Fn+F3)
- No activity under **auto-standby** enabled by the feature utility.

Events that cause exiting or resuming of standby mode:

- (Resume) Any key operation.

Suspend Mode: When the computer enters the suspend mode, the following occurs:

- The LCD backlight turns off.
- The LCD power is powered-off.
- The hard disk is powered-off.
- The CPU clock is set to the lowest speed.
- The CPU is stopped.
- In the ThinkPad Features Program, the computer can be set to "Will not suspend even if LCD is closed."
- When the computer is powered with ac power and is used with one of the following IBM PC cards, the computer will only enter the *standby mode*. The PC card and application program remain active.
 - 3270 Emulation Credit Card Adapter
 - 5250 Emulation Credit Card Adapter
 - Token-Ring 16/4 Credit Card Adapter
 - Credit Card Adapter for Ethernet

The following conditions prevent the computer from entering the suspend mode.

- While the communication link is running.
- When a serial mouse or external pointing device has been selected in the **Config** menu of the Easy-Setup.

Events that cause the computer to enter the suspend mode:

- Suspend mode is requested by the Fn key (Fn+F4).
- The LCD is closed.
- The keyboard is opened.
- The specified time has elapsed from the last operation with the keyboard, mouse, hard disk drive, parallel connector, diskette drive, or the AC Adapter is plugged in. The time is specified by **Suspend Timer** in the ThinkPad Features program.
- The battery condition is low. The battery power indicator blinks (orange).
- *The PS2 OFF* command is set in the ThinkPad Features program.

Events that cause exiting or resuming of the suspend mode:

- (Resume) The LCD is opened.
- (Resume) The keyboard is closed.
- (Resume) Real time clock alarm signaled.
- (Resume) Ring indicator (RI) signaled by serial or PCMCIA device.
- (Resume) The Fn key is pressed.
- (Exit) Timer conditions are satisfied to enter hibernation mode.

Hibernation Mode: When in hibernation mode, the following occurs:

- The system status, RAM, VRAM, and setup data are stored on the hard disk.
- The system is powered-off.

Events that prevent the computer from entering the hibernation mode.

- A serial mouse or external pointing device has been selected in the **Config** menu of the Easy-Setup.
- The computer is powered with ac power and one of the following IBM PC cards is used.
 - PCMCIA Data/FAX Modem
 - High Speed PCMCIA Data/FAX Modem
 - 3270 Emulation Credit Card Adapter
 - 5250 Emulation Credit Card Adapter
 - Token-Ring 16/4 Credit Card Adapter
 - Credit Card Adapter for Ethernet

Events that cause the computer to enter the hibernation mode.

- Pressing the Fn key (Fn+F12).
- Timer conditions are satisfied in suspend mode.
- Critical low battery condition.

Event that causes the computer to exit the hibernation mode.

- The power-on switch is operated.

When power is turned on, the hibernation history of the boot record on the hard disk is recognized and system status is restored from the hard disk to resume operation.

Port Replicator Power Overload: If intermittent power shut-downs occur while using PCMCIA-2 devices through a port replicator, suspect an over-current problem. Some PCMCIA devices use too much power, and if the maximum usage of each device occurs simultaneously, the total current could exceed the replicator limit, thereby causing a power shut down. Remove each device one at a time and repeat the sequence until problem fails to return. Ten determine the cause.

Symptom-to-FRU Index

The Symptom-to-FRU Index lists the symptoms and errors and the possible causes. The most likely cause is listed first.

Perform the FRU replacement or actions in the sequence shown in the “FRU/Action” columns. If a FRU did not solve the problem, put the original part back in the computer. Do not replace a non-defective FRU.

This index can also be used to help you decide which FRUs to have available when servicing a computer.

Numeric error codes show the errors detected in POST or system operation. In the following error codes, **X** can be any number.

If no codes are available, use narrative symptoms.

If the symptom is not listed, go to “Undetermined Problems” on page 343.

Note: For IBM devices not supported by diagnostic codes of the ThinkPad computers, see the manual for that device.

Numeric Error Codes

Symptom/Error	FRU/Action
10X	1. System Board
110	1. Go to “Memory Checkout” on page 317. 2. IC DRAM Card or DIMM Card 3. System Board
111	1. Go to “Memory Checkout” on page 317. 2. Expansion Unit/Port Replicator 3. System Board
158 (HDP was not set even though the supervisor password is set.)	1. Set a HDP.
159 (HDP is not set the same as the supervisor password.)	1. Set a correct HDP.
161	1. Go to “Checking the Backup Battery” on page 326. 2. Backup Battery 3. System Board

Symptom/Error	FRU/Action
163 (Time and Date was not set.)	<ol style="list-style-type: none"> Set Time and Date. System Board
173 (Configuration data were lost.)	<ol style="list-style-type: none"> Select OK in the error screen; then set time and date. Backup Battery System Board
174 (Perform "Checking the Installed Devices List" on page 346 before changing any FRUs.)	<ol style="list-style-type: none"> Check Device Configuration. System Board Diskette Drive Assembly Hard Disk Drive Assembly
175, 177, 178	<ol style="list-style-type: none"> System Board
183 (Incorrect password entered at the supervisor password prompt.)	<ol style="list-style-type: none"> Have the user examine the password.
184 (POP check sum error.)	<ol style="list-style-type: none"> Reset the POP in Easy-Setup.
185 (The startup sequence is not valid. Suspect that power was off when the startup sequence was being updated.)	<ol style="list-style-type: none"> Reset the startup sequence in Easy-Setup.
186	<ol style="list-style-type: none"> System Board
188	<ol style="list-style-type: none"> Set the system identification using the ThinkPad 750Ce hardware maintenance diskette.
190 (Depleted battery pack was installed when the power was on.)	<ol style="list-style-type: none"> Go to "Checking the Battery Pack" on page 324.
191XX	<ol style="list-style-type: none"> System Board Processor card
195 (The configuration read from the hibernation area does not match the actual configuration.)	<ol style="list-style-type: none"> Check if the configuration was changed. For example, check if the disk drive is from another computer.
196 (Read error occurred in the hibernation area of the HDD.)	<ol style="list-style-type: none"> Run the hard disk drive test. Hard Disk Drive
199XX	<ol style="list-style-type: none"> System Board
1XX	<ol style="list-style-type: none"> System Board

Symptom/Error	FRU/Action
2XX	<ol style="list-style-type: none"> 1. Go to “Memory Checkout” on page 317. 2. IC DRAM Card, DIMM, or DIMM Adapter 3. System Board
301, 303, 304, 305, 3XX	<ol style="list-style-type: none"> 1. Go to “Keyboard/Auxiliary Input Device Checkout” on page 320. 2. Keyboard 3. Video Card 4. External Numeric Keypad 5. External Keyboard 6. Keyboard/Mouse Cable 7. System Board
601, 6XX	<ol style="list-style-type: none"> 1. Go to “Diskette Drive Test” on page 321. 2. Diskette Drive Assembly 3. Diskette 4. System Board
602 (Diskette read error.)	<ol style="list-style-type: none"> 1. Go to “Diskette Drive Test” on page 321. 2. Diskette 3. Diskette Drive Assembly
604 (Non-acceptable ID was read from the diskette drive.)	<ol style="list-style-type: none"> 1. Go to “Diskette Drive Test” on page 321. 2. Diskette Drive Assembly 3. System Board
11XX	<ol style="list-style-type: none"> 1. Serial Device (First) 2. Communication Cable 3. System Board
12XX	<ol style="list-style-type: none"> 1. Serial Device (Second) 2. Communication Cable 3. System Board
17XX	<ol style="list-style-type: none"> 1. Hard Disk Drive 2. System Board
24XX	<ol style="list-style-type: none"> 1. System Board 2. Video Card
808X	<ol style="list-style-type: none"> 1. PCMCIA Slot Assembly 2. PCMCIA Device 3. System Board
860X (Pointing device error when TrackPoint III is disabled.)	<ol style="list-style-type: none"> 1. External Mouse 2. External Keyboard 3. System Board

Symptom/Error	FRU/Action
861X (Pointing device error when TrackPoint III is enabled.)	<ol style="list-style-type: none"> Reseat the keyboard Track Point III cable at the interposer card. See "2080 Keyboard Unit" on page 359. Keyboard External Mouse Video Card System Board
I9990301 I9990302 I9990305	<ol style="list-style-type: none"> Reseat the boot device. Check the startup sequence for the correct boot device. Check that operating system has no failure, or is installed correctly.
I9990303	<ol style="list-style-type: none"> System Board
Other codes not listed above	<ol style="list-style-type: none"> Go to "Undetermined Problems" on page 343.

FRU Codes

If an error is detected by the diagnostic tests, a *four-digit* FRU code is displayed. The FRU code indicates two suspected FRUs. Replace the FRU that is indicated by the *two leftmost digits* first, then replace the FRU indicated by the *two rightmost digits*. No FRU is assigned to code 00. If only one FRU is suspected, the other FRU code is filled with zeros. See the referenced page before replacing the FRU.

FRU Code	FRU/Action
10	System Board
11	Processor Card
16	DSP Card
17	Front IR unit
18	Rear IR unit
20	Memory (See "Memory Checkout" on page 317.)
30	Reserved
32	External Keyboard
33	External Mouse
40	LCD Assembly
41	Video Card
45	External CRT
50	<ol style="list-style-type: none"> Reseat the Drive (FDD-1) Diskette Drive (FDD-1)

FRU Code	FRU/Action
51	<ol style="list-style-type: none"> 1. Reseat the Drive (FDD-2) 2. Diskette Drive (FDD-2)
60	<ol style="list-style-type: none"> 1. Reseat the Hard Disk Drive (HDD-1) 2. Hard Disk Drive (HDD-1)
61	<ol style="list-style-type: none"> 1. Reseat the Hard Disk Drive (HDD-2) 2. Hard Disk Drive (HDD-2)
70	PCMCIA-2 (Replicator)
71	PCMCIA (under CD-ROM drive)
80	Cellular Modem
90	CD-ROM Drive

Note: The device ID and error codes are used to indicate the detail portion of the FRU which caused the error. If replacing a FRU does not correct a problem, see the Device ID or error code from the previous failure. If they have changed, the cause might be because the new FRU is defective or that the FRU was incorrectly installed.

If the problem remains after replacement of the FRUs, go to “Undetermined Problems” on page 343.

Beep Symptoms

Symptom/Error	FRU/Action
Continuous beeps.	System Board
One beep and a blank, unreadable, or flashing LCD.	<ol style="list-style-type: none"> 1. Reseat all LCD connectors. 2. LCD Assembly 3. Video Card 4. System Board 5. DC/DC Card
One beep, and the message “Unable to access boot source.”	<ol style="list-style-type: none"> 1. Boot device 2. System Board
One long, two short beeps and a blank or unreadable LCD.	<ol style="list-style-type: none"> 1. System Board 2. Video Card 3. LCD Assembly
One long beep followed by four short beeps each time the power switch is operated. (System cannot power-on due to low battery voltage.)	Connect the AC Adapter or install a fully-charged battery.
One beep every second. (System is shutting down due to low battery voltage.)	Connect the AC Adapter or install a fully-charged battery (allows system to complete shutdown before changing the battery).
Two short beeps with error codes.	POST error. See “Numeric Error Codes” on page 331.

Symptom/Error	FRU/Action
Two short beeps with blank screen.	System Board

No Beep Symptoms

Symptom/Error	FRU/Action
No beep, power-on indicator not on, and a blank LCD during POST.	<ol style="list-style-type: none"> 1. Go to “Power Systems Checkout” on page 322. 2. System Board 3. DC/DC Card 4. Power sources
No beep, power-on indicator on, and a blank LCD during POST.	<ol style="list-style-type: none"> 1. System Board 2. DC/DC Card 3. Processor Card
No beep, power-on indicator on, and a blinking cursor only during POST.	<ol style="list-style-type: none"> 1. System Board 2. Processor Card 3. DC/DC Card
No beep during POST but system runs correctly.	<ol style="list-style-type: none"> 1. Turn the volume up and check the speaker 2. Speaker 3. DSP Card 4. DC/DC Card

LCD Related Symptoms

The TFT LCD for the notebook computer contains over 921 000 thin film transistors (TFTs). A small number of missing, discolored or lighted dots (on all the time) is characteristic of TFT LCD technology, but excessive pixel problems can cause viewing concerns.

Before Replacing the LCD

The LCD should not be replaced unless the number of dots satisfies the following condition:

- The number of missing or discolored, or lighted dots in any colored background is 21 or more.

Note: For Model 755CDV, see also “Model 755CDV Symptoms” on page 337 for LCD related symptoms.

Symptom/Error	FRU/Action
No beep, power-on indicator on, and a blank LCD during POST.	<ol style="list-style-type: none"> 1. System Board 2. DC/DC Card 3. Video Card 4. Processor Card

Symptom/Error	FRU/Action
<ul style="list-style-type: none"> • LCD backlight not working, or • LCD too dark, or • LCD brightness cannot be adjusted, or • LCD contrast cannot be adjusted. 	<ol style="list-style-type: none"> 1. Reseat the LCD connectors. 2. LCD Assembly 3. Interposer Card 4. DC/DC Card
<ul style="list-style-type: none"> • LCD screen unreadable, or • Characters missing pels, or • Screen abnormal, or • Wrong color displayed. 	<ol style="list-style-type: none"> 1. See the preceding note on replacing LCDs. 2. Reseat all LCD connectors. 3. LCD Assembly 4. System Board 5. Video Card 6. Interposer Card
LCD has extra horizontal or vertical lines displayed.	LCD Assembly

Model 755CDV Symptoms

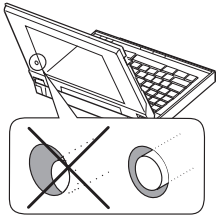
Symptom/Error	FRU/Action
The screen is black when the LCD cover is installed.	<ol style="list-style-type: none"> 1. Verify that the LCD cover is firmly installed on the LCD. 2. Diagnose the LCD assembly by following "LCD Related Symptoms" on page 336.
The LCD is wavy when the computer is placed on the overhead projector.	Some overhead projectors interfere with the LCD of the computer. Use another overhead projector.
The LCD stays on even when the LCD cover is removed.	<p>Make sure that the switch on the rear of the LCD is not stuck. If it is stuck, release it with the tip of a ball-point pen.</p> 

Symptom/Error	FRU/Action
<ul style="list-style-type: none"> • Abnormal screen • Uneven color on the screen • Spot on the screen 	<ol style="list-style-type: none"> 1. Check that the white film on the LCD cover is clean. Gently wipe the film with a dry, soft cloth, such as a lens cleaner. 2. LCD Cover 3. Diagnose the LCD assembly by following "LCD Related Symptoms" on page 336. <p>Note: The customer may be responsible for repair costs if the LCD cover was damaged due to misuse, excessive force, scratch, or liquid spilled by the customer.</p>
<p>The computer has an intermittent problem when you use it on the overhead projector.</p>	<p>Problem such as high environmental temperature might be the cause. Use the stand supplied with the computer.</p>
<p>The remote control does not work.</p>	<ol style="list-style-type: none"> 1. Check that two AAA alkaline batteries are installed in the remote control. 2. Check that two AAA alkaline batteries in the remote control are at their normal energy (voltage) level. 3. Enable the IR port of the computer with the ThinkPad Features program. (Disable the serial port at this time.) 4. Refer to the trouble shooting section in the Help menu of the Mind Path Presentation F/X program. Set up this program following the guide. 5. If the preceding items are correct, the radiation from the light of the overhead projector might be interfering the IR port of the computer. Disable the rear IR port of the computer, and use the remote control with the front IR port. 6. Use the remote control with another computer, which IR port works normally. If the remote control does not work, the remote control is not working properly. <p>If there is still a problem, refer to "Infrared Related Symptoms" on page 342.</p>

Keyboard/TrackPoint III Related Symptoms

Symptom/Error	FRU/Action
Keyboard (one or more keys) does not work.	<ol style="list-style-type: none"> 1. Reseat the three keyboard cables. 2. Keyboard 3. Video Card 4. System Board
TrackPoint III does not work.	<ol style="list-style-type: none"> 1. Go to “TrackPoint III Checkout” on page 320. 2. Keyboard 3. Video Card 4. System Board
Pointer moves automatically or does not work correctly.	<ol style="list-style-type: none"> 1. See “TrackPoint III Checkout” on page 320.

Indicator Related Symptoms

Symptom/Error	FRU/Action
Indicator incorrectly remains off or on, but system runs correctly.	<ol style="list-style-type: none"> 1. Reseat the status indicator cable. 2. Status Indicator 3. Interposer Card 4. System Board
Battery power status indicator blinks from green, yellow, to orange.	<ol style="list-style-type: none"> 1. Check that a correct battery is installed. 2. Set the battery storage switch to ON. 3. Battery Pack 4. DC/DC Card 5. System Board

Power Related Symptoms

Symptom/Error	FRU/Action
Power shut down during operation.	<ol style="list-style-type: none"> 1. Go to “Power Systems Checkout” on page 322. 2. Battery Pack 3. Remove the battery pack and let it cool for two hours. 4. DC/DC Card 5. Power sources
The system will not power-off. (See “Reset Pushbutton” on page 346.)	<ol style="list-style-type: none"> 1. Press the Reset pushbutton. 2. System Board

Function/Audio Related Symptoms

Symptom/Error	FRU/Action
The system will not suspend or resume by opening or closing the keyboard.	<ol style="list-style-type: none">1. Go to “Suspend Mode” on page 329 and check that the computer can enter suspend mode.2. DC/DC Card3. Video Card4. System Board
The system will not suspend or resume by opening or closing the LCD.	<ol style="list-style-type: none">1. Go to “Suspend Mode” on page 329 and that check that the computer can enter suspend mode.2. Top Cover3. DC/DC Card4. System Board
Battery Fuel-Gauge does not go higher than 90%.	Go to “Checking the Battery Pack” on page 324 and see the note.
Memory count (size) appears differently from actual size.	Go to “Memory Checkout” on page 317.
System configuration does not match the installed devices.	Go to “Checking the Installed Devices List” on page 346.
System hangs intermittently.	Go to “Intermittent Problems” on page 342.

Peripheral Device Related Symptoms

Symptom/Error	FRU/Action
External display does not work correctly.	1. See "External Display Self-Test" in "Common Devices Checkout" section.
Printer problems.	1. Run Printer Self-test. 2. Parallel Port Device 3. Cable 4. System Board
Serial or parallel port device problems.	1. Device 2. Device Cable 3. System Board

Other Symptoms

Symptom/Error	FRU/Action
Errors occur only when Port Replicator is used.	See "Port Replicator Checkout" in "Common Devices Checkout" section.
PCMCIA slot pin is damaged.	PCMCIA Slots Assembly

Note: If you cannot find a symptom or error in this list and the problem remains, see "Undetermined Problems" on page 343.

Infrared Related Symptoms

Symptom/Error	FRU/Action
Unable to communicate using the Infrared (IR) Port	<ol style="list-style-type: none">1. Make sure the setup for the IR is correct.2. Make sure there are no fluorescent lights near the computer. The computer may receive electrical noise from the fluorescent light.3. Run the advanced diagnostic test. If an error occurs and a FRU code is displayed, replace the parts shown by the FRU code.4. For Model 755CDV, if the remote control is enabled, the communication with the IR port is disabled. Run the Mind Path Presentation F/X program and set the infrared to OFF; then observe the symptom.

Intermittent Problems

Intermittent system hang problems can be caused by a variety of reasons that have nothing to do with a hardware defect such as: cosmic radiation, electrostatic discharge, or software errors. FRUs replacement should only be considered when a recurring problems exists.

When analyzing the intermittent problem, do the following:

1. Run the advanced diagnostic test for the system board in loop mode at least 10 times.
2. If no error is detected, do **not** replace any FRUs.
3. If any error is detected, replace the FRU shown by the FRU code. Rerun the test to verify that no more errors exist.

Undetermined Problems

You are here because the diagnostic tests did not identify which adapter or device failed, installed devices are incorrect, a short circuit is suspected, or the system is inoperative. Follow the procedures below to isolate the failing FRU (do not isolate non-defective FRUs).

Verify that all attached devices are supported by the computers.

Verify that the power supply being used at the time of the failure is operating correctly. (See "Power Systems Checkout" on page 322.)

1. Power-off the computer.
2. Check the cables, wires, and connectors for short circuits and open circuits. Visually check them for damage. If any problems are found, replace the FRU.
3. Remove or disconnect all of the following devices.
 - a. Non-IBM devices
 - b. Devices attached to the expansion bus connector
 - c. Printer, mouse, and other external devices
 - d. Battery pack
 - e. Hard disk drive
 - f. Diskette drive or the device attached to the diskette drive connector
 - g. IC DRAM card or DIMM card
 - h. PC Cards

Note: Remember that removing the hard disk drive, an IC DRAM card, or any adapter or device, might cause configuration errors. Ignore error code 174.

4. Power-on the computer.
5. Determine if the problem has changed.
6. If the problem does not occur again, reconnect the removed devices one at a time until you find the failing FRU.
7. If the problem remains, replace the following FRUs one at a time. Do not replace a non-defective FRU.
 - DC/DC card
 - Interposer card
 - LCD assembly
 - System board
 - Processor card









Related Service Procedures





This section provides information about the following:

- “Status Indicators”
- “How to Run the Diagnostics” on page 345
- “Error Log” on page 346
- “Reset Pushbutton” on page 346
- “Checking the Installed Devices List” on page 346
- “Password Combinations (POP, HDP, PAP)” on page 347
- “How to Run the Low Level Format” on page 347
- “PC Test Card LED” on page 347
- “Fn Key Combinations” on page 348
- “How To Run the Keyboard Diagnostics” on page 348

Status Indicators

The system status indicators show the current computer status in different colors (green, yellow, and orange).

Symbol	Color	Meaning
	Blinking green	Speaker sounds
	Green	Battery fully charged
	Yellow	Battery usable
	Orange	Battery low, or if  is green, the operational charge cannot be performed.
	Blinking orange	Battery almost depleted
	Blinking green, yellow, and orange	Battery storage switch is set off
	Orange, or Green, or Yellow	if  is blinking twice every 3 seconds, the battery is discharging.
	Green	Battery charging
	Orange	PC card in-use
	Orange	Diskette drive in-use
	Orange	Hard disk drive in-use
	Green	Keys in Num Lock mode

Symbol	Color	Meaning
	Green	Keys in Caps Lock mode
	Green	Keys in Scroll Lock mode
	Green	Computer in suspend mode
	Blinking green	Computer resuming normal mode
	Green	Computer powered on

How to Run the Diagnostics

Use either the TrackPoint III or the cursor move keys to interact with the tests. The Enter key works the same as selecting the OK icon to reply OK.

1. Press and hold the F1 key; then power-on the computer. Hold the F1 key down until Easy-setup screen appears.
2. Select **Test** and press Enter.
3. Select a device and press Enter to run the test. To test the Infrared Port, click the "SystemBoard" icon.
4. The test progress screen appears.
5. **OK** appears when the test ends without any errors.
6. Start the **Advanced Diagnostic test** by pressing **Ctrl+A** on the basic diagnostic menu screen.
7. Select **Tool** to install the tools.
8. Select a device, press the **space** key, and install the tool. Multiple devices can be selected by repeating this step.
A √ mark appears for the selected device.
9. Select **OK** and press Enter if the selection is OK.
10. Select a device and press Enter to start the tests.
11. Select **Test All** to test all devices.
12. Select **Loop Test** to loop tests.
A loop option menu appears in which a device loop or all loop can be selected. Select a device and press the **space** key to select a device. Repeat this step to select multiple devices. Press Enter to start the diagnostic loop. If no device is selected, all device tests are looped.
13. To exit the loop, keep pressing **Ctrl+Pause** until the test exits. A beep sounds to notify that the exit interrupt is sensed by the test program.

Error Log

Diagnostic errors are printed on the printer that is attached to the parallel port when the error is detected. The error is also logged in the system memory.

Do the following to display the errors.

1. End the test, if it is running.
2. Press **Ctrl+A** to select the advanced diagnostic mode.
3. Press **Ctrl+E**.
4. The error log appears.
5. To exit the screen, select the cancel icon or press Esc.

The error log is not saved when system power is powered-off.

Reset Pushbutton

The reset pushbutton resets the system and forces the power to be powered-off. Use this pushbutton when the power is not completely off or the system is hung. See "Rear View" on page 382 for the location of the pushbutton.

Checking the Installed Devices List

If a device is installed but the icon appears in a gray shade rather than a dark shade on the basic diagnostics screen, the device is defective. Reseat the device connectors. If the symptom remains, replace the device or the system board. If needed, adjust the contrast control to clearly distinguish the shades of the icon.

If a device that is not installed appears in a dark shade, for example, FDD-2 appears in a dark shade when *NO* second FDD is installed, do the following.

1. Replace the **first** device, such as a FDD-1, HDD-1, or PCMCIA-1.
2. If the problem remains, replace the system board.

PCMCIA-1, Parallel, and Serial icons are always displayed in dark shade, because the icons represent subsystems of the system board and not attachment of the devices.

The HDD-1, FDD-1, or PCMCIA-1 represents the **first** drive in the system configuration, respectively. Similarly, the HDD-2, FDD-2, or PCMCIA-2 represents the **second** drive, usually attached through a port replicator or an expansion unit.

Password Combinations (POP, HDP, PAP)

The password relationship is:

- **When POP is the same as HDP**
The POP prompt appears, but the HDP prompt does not appear.
- **When POP is not the same as HDP**
Both POP and HDP prompts appear.
- **PAP and HDP**
When PAP is used, the HDP is enabled automatically, but no HDP prompt appears. The HDP is set the same as PAP.

How to Run the Low Level Format

Do the following to format the hard disk.

Warning: Make sure the drive address to be formatted is correct. This procedure will erase all information on the disk.

1. Power-off the computer.
2. Insert the **ThinkPad 755Ce hardware maintenance diskette** into diskette drive **A** and power-on the computer.
Note: You can use this maintenance diskette for all models.
3. Select **Format the hard disk** from the main menu.
4. Select the drive from the menu.
5. Follow the instructions on the screen.

PC Test Card LED

The green LED on the PC test card turns on when the PCMCIA test is running. If the LED does not turn on, check that the card is installed correctly by reseating the card. If it still does not turn on after it is reseated, try using another slot for the test. If the LED still does not turn on and the test fails, replace the FRU shown in the diagnostic error code.

Fn Key Combinations

The following table shows the **Fn** key and function key combinations and their corresponding functions.

The Fn key works independently from the operating system. The operating system obtains the status through the system management interface to control the system.

Fn +	Description
F1	Reserved
F2	Fuel-gauge display ON/OFF
F3	Standby mode invocation
F4	Suspend mode invocation
F5	Reserved
F6	Reserved
F7	LCD/CRT display switching
F8	Reserved
F9	Reserved
F10	Reserved
F11	Power management mode switching (Toggles High power, Intelligent, Economy)
F12	Hibernation invocation

How To Run the Keyboard Diagnostics

Do the following to run the keyboard test.

1. Go to the advanced diagnostic screen menu by pressing **Ctrl+A** in Easy-Setup menu.
2. Go to the keyboard diagnostic test menu by pressing **Ctrl+K**.
3. Check that when each key is pressed, the key position on the keyboard layout on the screen changes to a black square.

Note: When a Fn key is pressed, a black square briefly appears.

Product Overview

The following table shows an overview of the system features.

Feature	Description
Processor	Intel 486DX4 100/33 MHz
Bus Architecture	<ul style="list-style-type: none">• AT Bus• VESA Local Bus for video subsystem
Memory (Standard)	8MB (on the system board)
Memory (Option)	<ul style="list-style-type: none">• 2, 4, 8, 16MB, Basic IC DRAM card (max. 16 MB)• 4, 8, 16MB, DIMM card (max. 40 MB)• DIMM card adapter
CMOS RAM	128 Bytes
VGA Video	10.4-inch, 64K color, TFT LCD color
Diskette Drive (Removable)	<ul style="list-style-type: none">• 0.720, 1.2, 1.44, 2.88MB (4-mode), 3.5-inch• 0.720, 1.44, (2-mode), 3.5-inch
Hard Disk Drive (Removable)	<ul style="list-style-type: none">• 340MB, 2.5-inch• 540MB, 2.5-inch• 810MB, 2.5-inch
Super Video Card	<ul style="list-style-type: none">• Video accelerator• Video capture/overlay• Video composite In/Out
CD-ROM	<ul style="list-style-type: none">• 5-inch• Double speed• IDE interface
DSP Card	<ul style="list-style-type: none">• Microphone jack• Headphone jack• Modem port
IR	Two infra-red ports
PCMCIA	One Type-III or two Type-II

FRU Removals and Replacements

This section contains information about removals and replacements.

- An electrostatic discharge (ESD) strap must be used to establish personal grounding.
The system board is sensitive to, and can be damaged by, electrostatic discharge. Establish personal grounding by touching a ground point with one hand before touching these units.
- The arrows in the “Removals and Replacements” section show the direction of movement to remove a FRU, or to turn a screw to release the FRU. The arrows are marked in numeric order, in square callouts, to show the correct sequence of removal.
- When other FRUs must be removed before removing the failing FRU, they are listed at the top of the page.
- To replace a FRU, reverse the removal procedure and follow any notes that pertain to replacement. See “Locations” for internal cable connections and arrangement information.
- When replacing a FRU, use the correct screw size as shown in the procedures.

— **Safety Notice 8: Translation on page 13** —

Before removing any FRU, power-off the computer, unplug all power cords from electrical outlets, remove the battery pack, and then disconnect any interconnecting cables.

— **Safety Notice 3: Translation on page 9** —

The battery pack contains small amounts of nickel. Do not disassemble it, throw it into fire or water, or short-circuit it. Dispose of the battery pack as required by local ordinances or regulations.

— **Safety Notice 1: Translation on page 7** —

Before the computer is powered-on after FRU replacement, make sure all screws, springs, or other small parts, are in place and are not left loose inside the computer. Verify this by shaking the computer and listening for rattling sounds. Metallic parts or metal flakes can cause electrical short circuits.

2010 Rear Connector Door

Remove the center latch **1**; then remove the rear connector door by flexing it **2**.

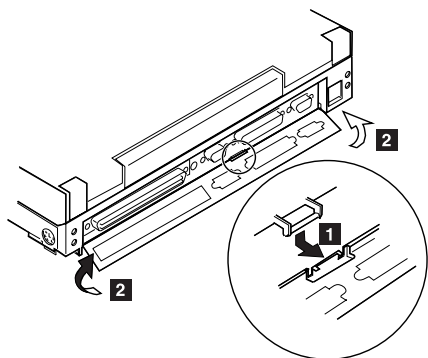

2015 Foot

To replace the foot:

- Align the foot in the open position with one pivot in its hinge in the base cover
- Press the other pivot point into position with your thumb or finger

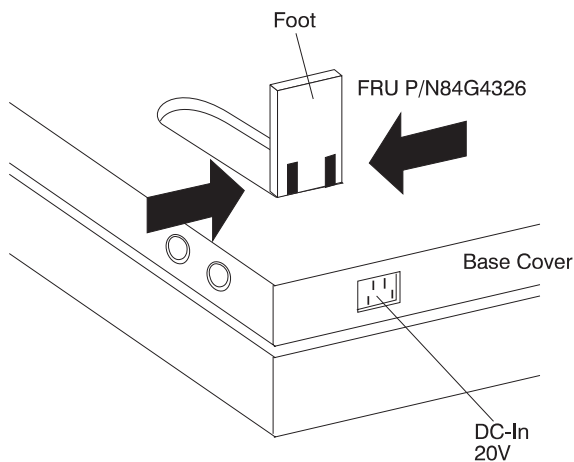

2020 Battery Pack

- CD-ROM Drive (2030)

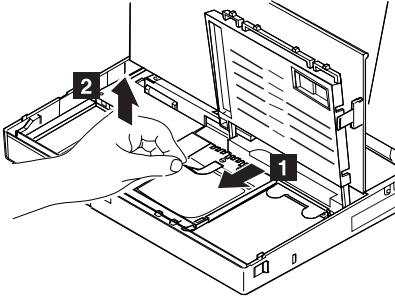

Notes:

1. Be careful that the computer does not fall backward when the battery pack is removed.
2. When replacing the battery pack, check that the storage switch of the new battery is set to the on (I) position. Do not operate the storage switch of a battery that has been used and is going to be re-used.
3. Check that the keyboard latch springs are in place.

2030 CD-ROM/Diskette Drive

Note: Remove the CD-ROM/Diskette drive exactly as shown in the figure. Do not apply any extra force to the CD-ROM/Diskette drive when removing it.

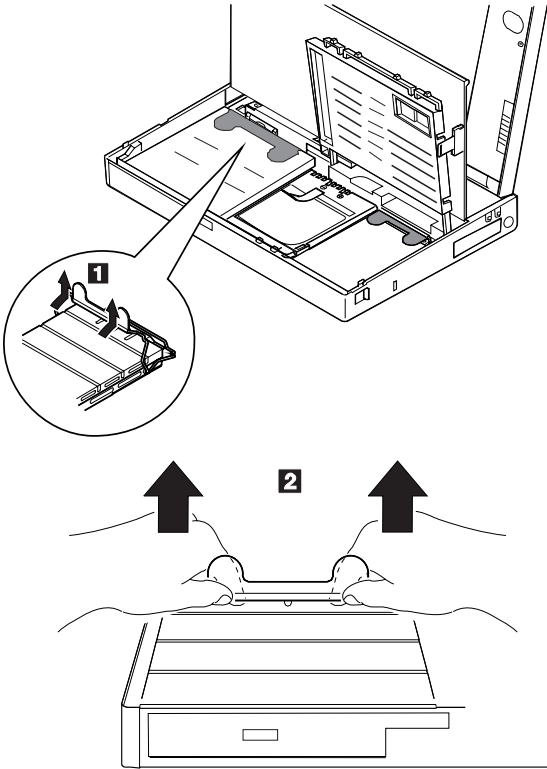

Warning: When replacing the CD-ROM/diskette drive, check that the standby battery is seated correctly to prevent damage to the drive.

2040 Hard Disk Drive

- CD-ROM Drive (2030)
- Battery Pack (2020)

Warning: Do not drop or apply any shock to the hard disk drive. The hard disk drive is sensitive to physical shock. Incorrect handling can cause damage it, and cause permanent loss of data on the hard disk. Before removing the hard disk drive, have the user make a backup copy of all the information on the hard disk. Never remove the hard disk drive while the system is operating or is in suspend mode.

Note: Remove the hard disk drive exactly as shown in the figure. Do not apply any extra force to the hard disk drive when removing it.

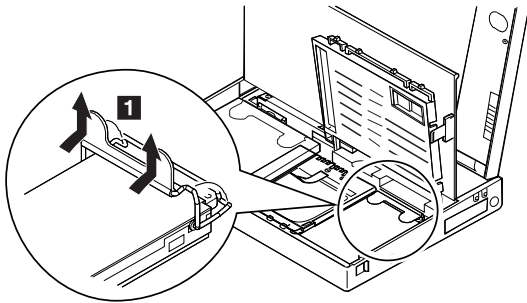

Warning: After replacing the hard disk drive, latch the removal strap into the correct position.

2050 IC DRAM Card or DIMM Adapter

- CD-ROM Drive (2030)
- Battery Pack (2020)

Note: One of the following combinations occupies the slot depending on the configuration.

- IC DRAM card + IC DRAM card base
- DIMMs on DIMM adapter

If the IC DRAM Card is installed:

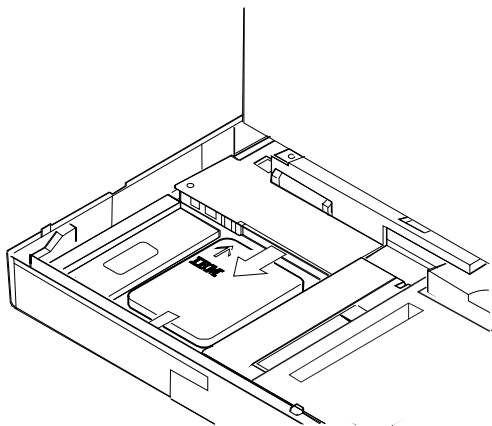

Warning: The IC DRAM card is sensitive to physical shock. Incorrect handling of the card can damage it. The eject tape (P/N 53G9318) must be used to remove the card.

If the DIMM Adapter is installed:

Press both locks at the same time and remove the DIMM.

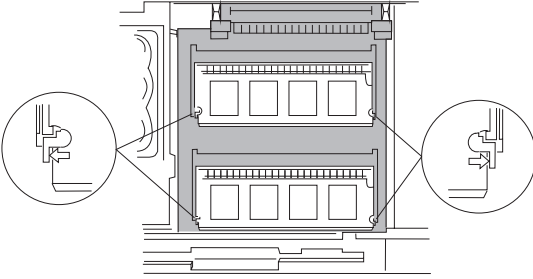

While holding the strap **A**, pull the DIMM adapter toward the front to remove it.

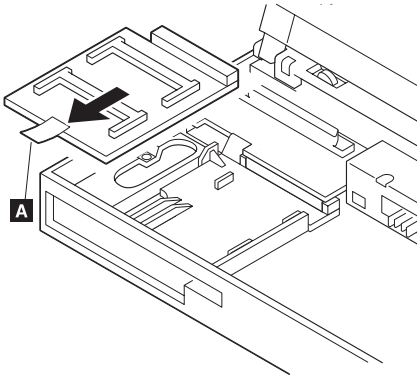

Notes:

1. If the IC DRAM cards or the DIMM are not installed and the base plate is installed instead of these cards, remove the plate as follows:
 - a. Pinch the projection **A** on the left side of the plate; then pull the plate slightly toward the front.
 - b. Raise the rear portion of the plate and remove it.

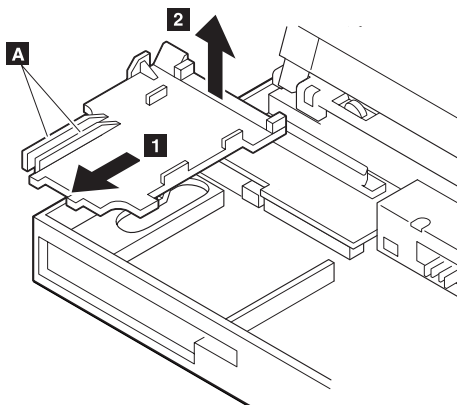

2. When inserting the DIMM into either connector on the DIMM adapter:
 - a. Locate the triangle **A** on the right side of the socket.
 - b. With the notched end of the DIMM **B** toward the triangle, insert the DIMM into the socket.
 - c. Pivot the DIMM until it snaps into place.

If you have another DIMM to install, insert it in the other socket the same way.

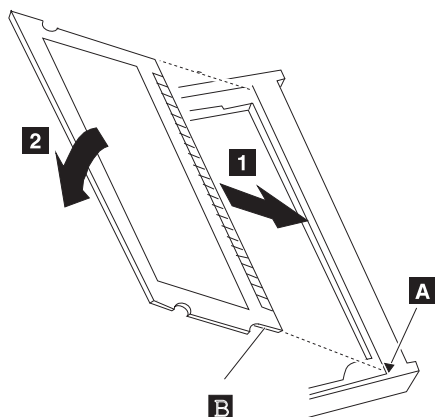

2060 Keyboard Spacer

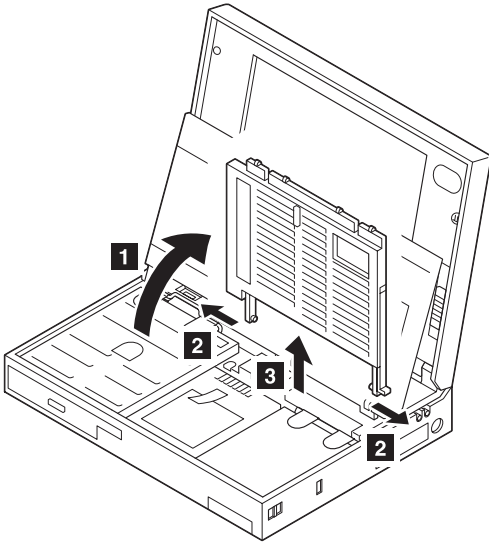

2080 Keyboard Unit

- CD-ROM Drive (2030)
- Battery Pack (2020)

Loosen the three screws **2** and **3**, and push **4** to release the five top cover latches at the rear side of the system unit.

When removing the screw covers **1**, use a small screwdriver.

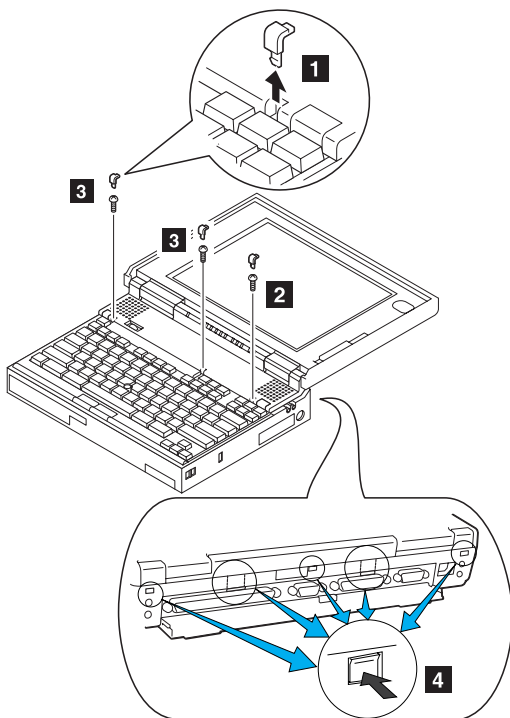

The keyboard unit is connected to the system board with flexible cables. Remove the upper cover; then disconnect the cables to remove the keyboard unit as shown.

To remove the top cover, do not latch the keyboard. Lower the keyboard and remove the top cover.

Warning: Do not pull the keyboard cables. The keyboard cables will be damaged if the keyboard is disconnected without releasing the three latches **7**.

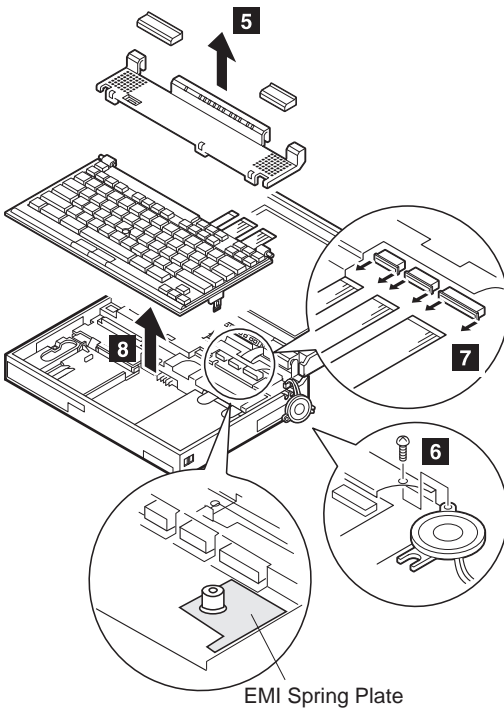

Notes:

1. When replacing the keyboard, check that the three cables are clean, and inserted straight and fully into the connectors. Slide both ends of each latch at the same time to make sure that each cable is correctly inserted. Go to "Keyboard/Auxiliary Input Device Checkout" on page 320 and test all keys before returning the computer to the customer.
2. When replacing the top cover, insert the four latches at the rear side of the cover into the foot guide of the the LCD; push the right, left, and front sides to snap it into place.

Use the following table for reference when replacing parts.

Step	Location (Quantity)	Length
2	Top cover (1)	14 mm
3	Top cover (2)	4 mm
6	Top cover (1)	4 mm

Note: Make sure you use the correct screw.

2090 Status Indicator

- CD-ROM Drive (2030)
- Battery Pack (2020)
- Keyboard Unit (2080)

Warning: Do not pull the status indicator cable. The cable will be damaged if the status indicator is disconnected without releasing the latch in step 2.

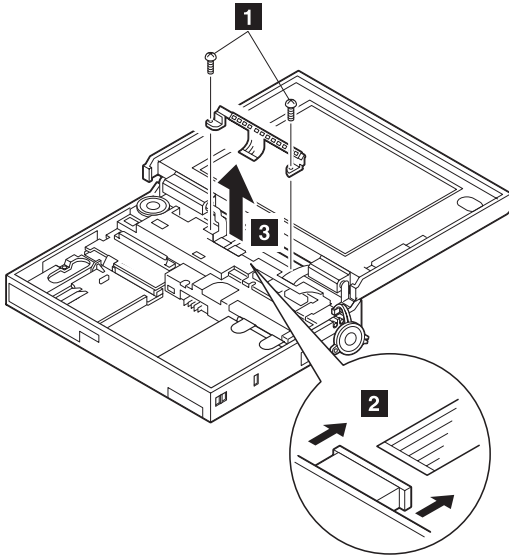

Note: When replacing the indicator, insert the flexible cable straight into the connector until the head of the cable stops. Slide both ends of the latches at the same time to make sure that the cable is correctly inserted.

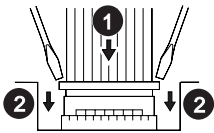

Use the following table for reference when replacing parts.

Step	Location (Quantity)	Length
1	LED Stand off (2)	14 mm
Note: Make sure you use the correct screw.		

2100 Standby Battery and Front IR

- CD-ROM Drive (2030)
- Battery Pack (2020)

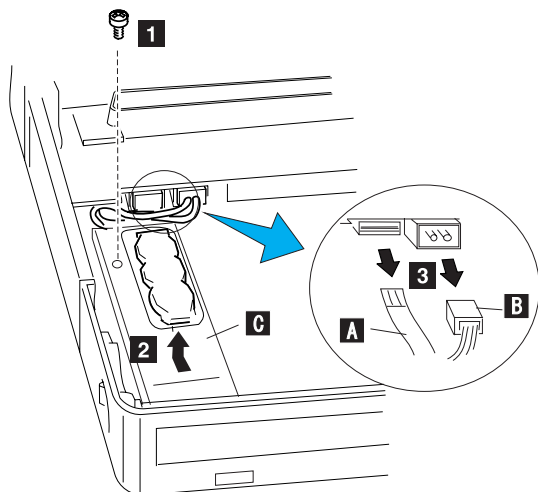

Where: **A** is the IR Cable. **B** is the Standby Battery Cable. **C** is the IR Lens.

Note: When replacing the battery, make sure the battery are seated correctly. Make sure the IR lens **2** is in the correct position by sliding it end to end.

Step	Location (Quantity)	Length
1	cover (1)	4 mm

Note: Make sure you use the correct screw.

Safety Notice 2: Translation on page 8

The standby battery contains a small amount of nickel and cadmium. Do not disassemble it, recharge it, throw it into fire or water, or short-circuit it. Dispose of the battery as required by local ordinances or regulations.

2110 Backup Battery

- CD-ROM Drive (2030)
- Battery Pack (2020)

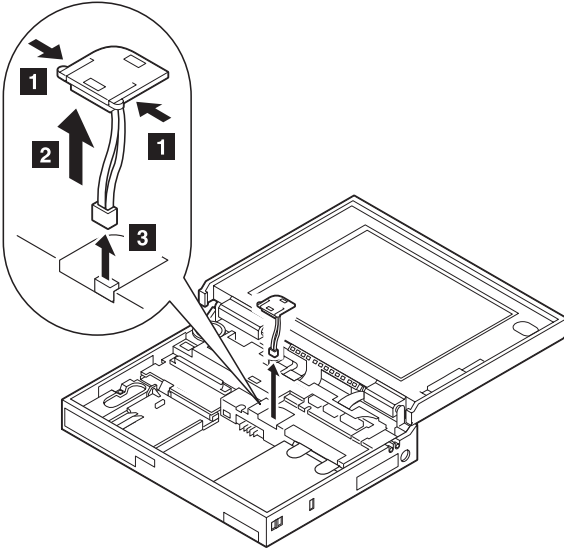

Safety Notice 4: Translation on page 10

The backup battery is a lithium battery and can cause a fire, explosion, or severe burn. Do not recharge it, remove its polarized connector, disassemble it, heat it above 100°C (212°F), incinerate it, or expose its cell contents to water. Dispose of the battery as required by local ordinances or regulations. Use of an incorrect battery can result in ignition or explosion of the battery. Replacement batteries can be ordered from IBM or IBM Authorized Dealers.

2115 Logic Assembly

- CD-ROM Drive (2030)
- Battery Pack (2020)
- Hard Disk Drive (2040)
- Keyboard Unit (2080)
- Status Indicator (2090)
- Standby Battery and Front IR (2100)
- Backup Battery (2110)

The screw **1** is located at the rear bottom side.

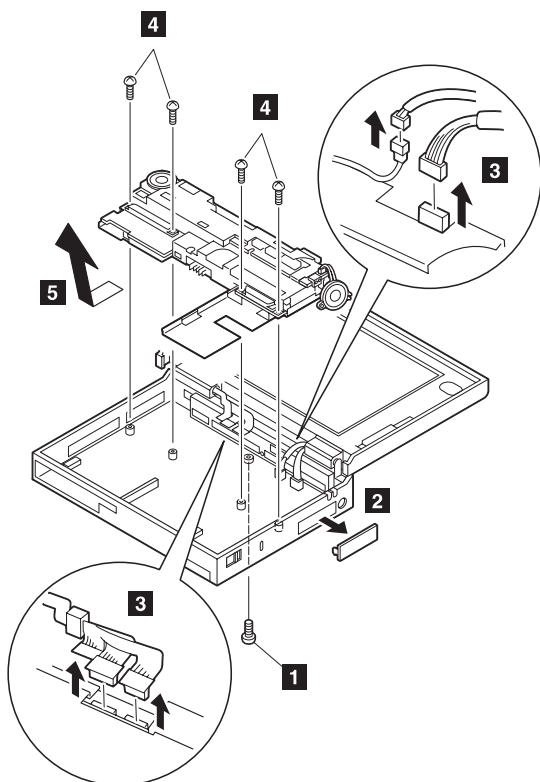

See next page.

Note: When replacing the logic assembly, align the power-key slide hub with the power-switch actuator by moving the power-key in the direction of the arrow. See the large circle in the figure. Before tightening any screws, check that the power-switch operates correctly.

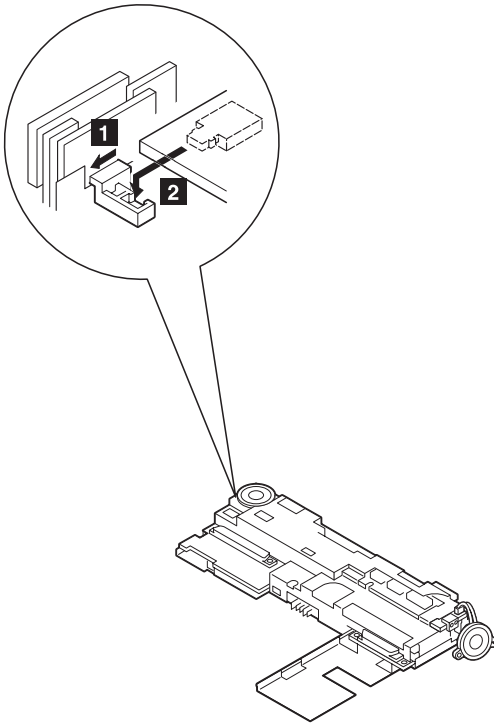

Step	Location (Quantity)	Length
1	Logic assembly (1)	4 mm
4	Logic assembly (4)	8 mm
Note: Make sure you use the correct screw.		

2120 Shield Assembly

- CD-ROM Drive (2030)
- Battery Pack (2020)
- Hard Disk Drive (2040)
- Keyboard Unit (2080)
- Status Indicator (2090)
- Standby Battery and Front IR (2100)
- Backup Battery (2110)
- Logic Assembly (2115)

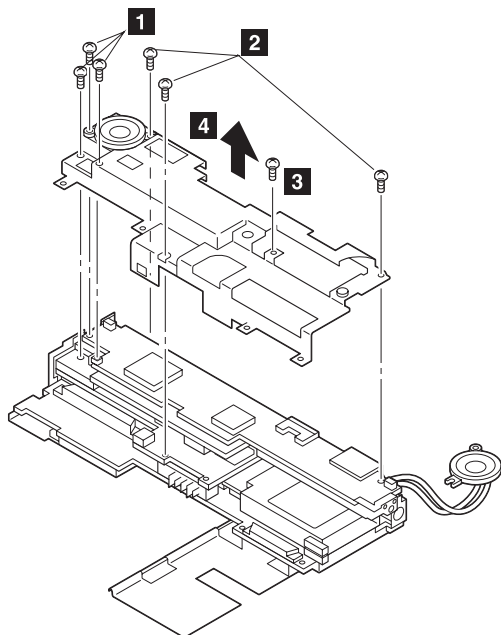

Step	Location (Quantity)	Length
1	Shield assembly (3)	4 mm
2	Shield assembly (3)	14 mm
3	Shield assembly (1)	8 mm
Note: Make sure you use the correct screw.		

2125 Video Card or Rear IR

- CD-ROM Drive (2030)
- Battery Pack (2020)
- Hard Disk Drive (2040)
- Keyboard Unit (2080)
- Status Indicator (2090)
- Backup Battery (2110)
- Standby Battery and Front IR (2100)
- Logic Assembly (2115)
- Shield Assembly (2120)

The connector is located under **A**.

Do **4** and **5** after step **3** to remove the rear IR.

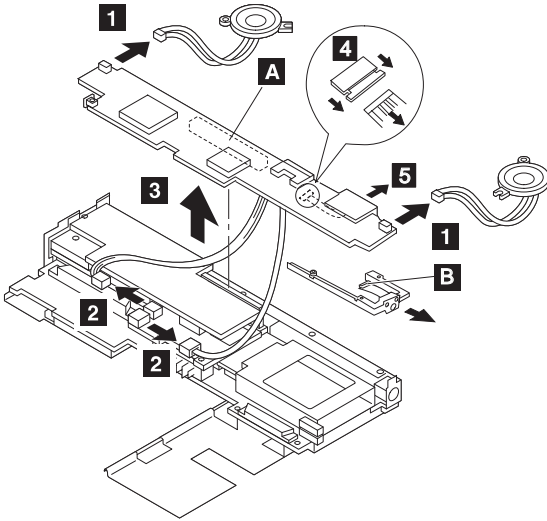

2130 DC/DC Card

- CD-ROM Drive (2030)
- Battery Pack (2020)
- Hard Disk Drive (2040)
- Keyboard Unit (2080)
- Status Indicator (2090)
- Backup Battery (2110)
- Standby Battery and Front IR (2100)
- Logic Assembly (2115)
- Shield Assembly (2120)
- Video Card or Rear IR (2125)

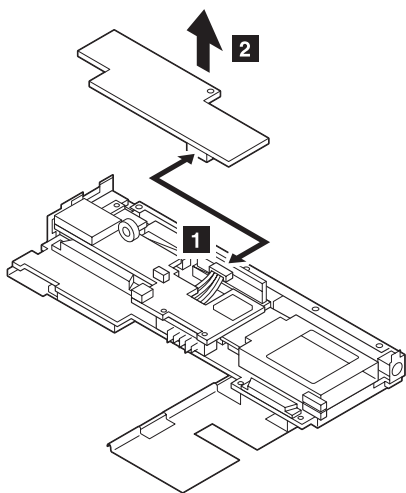

2140 DSP Card

- CD-ROM Drive (2030)
- Battery Pack (2020)
- Hard Disk Drive (2040)
- Keyboard Unit (2080)
- Status Indicator (2090)
- Backup Battery (2110)
- Standby Battery and Front IR (2100)
- Logic Assembly (2115)
- Shield Assembly (2120)
- Video Card or Rear IR (2125)
- DC-DC Card (2130)

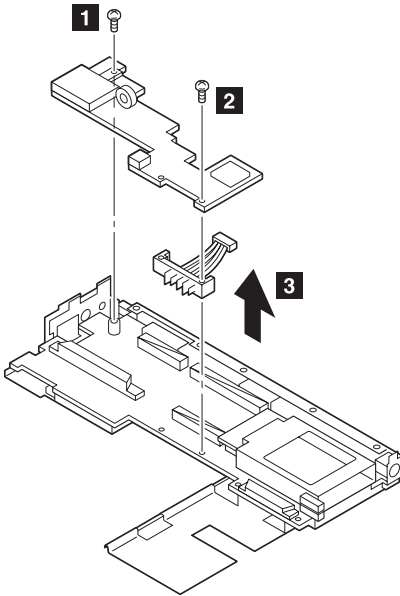

Remove the following:

- Mini-Jack Holder
- Modem Guide
- Modem Lever
- Microphone Cable

Use the following table for reference when replacing parts.

Step	Location (Quantity)	Length
1	DSP card (1)	8 mm
2	DSP card (1)	14 mm

Note: Make sure you use the correct screw.

2150 Interposer Card

- CD-ROM Drive (2030)
- Battery Pack (2020)
- Hard Disk Drive (2040)
- Keyboard Unit (2080)
- Status Indicator (2090)
- Backup Battery (2110)
- Standby Battery and Front IR (2100)
- Logic Assembly (2115)
- Shield Assembly (2120)
- Video Card or Rear IR (2125)
- DC-DC Card (2130)
- DSP Card (2140)

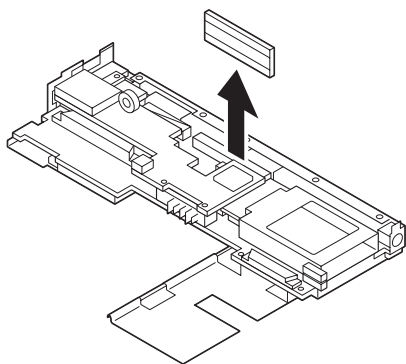

2160 System Board Assembly

- CD-ROM Drive (2030)
- Battery Pack (2020)
- Hard Disk Drive (2040)
- Keyboard Unit (2080)
- Status Indicator (2090)
- Backup Battery (2110)
- Standby Battery and Front IR (2100)
- Logic Assembly (2115)
- Shield Assembly (2120)
- Video Card or Rear IR (2125)
- DC/DC Card (2130)
- DSP Card (2140)
- Interposer Card (2150)
- Processor Card (2180)

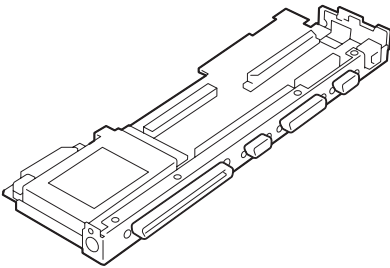

Notes:

1. Before removing and replacing the system board, make sure that the PCMCIA cards are removed and the eject levers are not sticking out.
2. When replacing the system board assembly, align the power-key slide hub with the power-switch actuator by moving the power-key in the direction of the arrow. See the large circle in the figure. Before tightening any screws, check that the power-switch operates correctly.
3. Do not pull the PCMCIA slot assembly while removing the system board.

2170 PCMCIA Slot Assembly

- CD-ROM Drive (2030)
- Battery Pack (2020)
- Hard Disk Drive (2040)
- Keyboard Unit (2080)
- Status Indicator (2090)
- Backup Battery (2110)
- Standby Battery and Front IR (2100)
- Logic Assembly (2115)
- Shield Assembly (2120)
- Video Card or Rear IR (2125)
- DC/DC Card (2130)
- DSP Card (2140)
- Interposer Card (2150)
- Processor Card (2180)

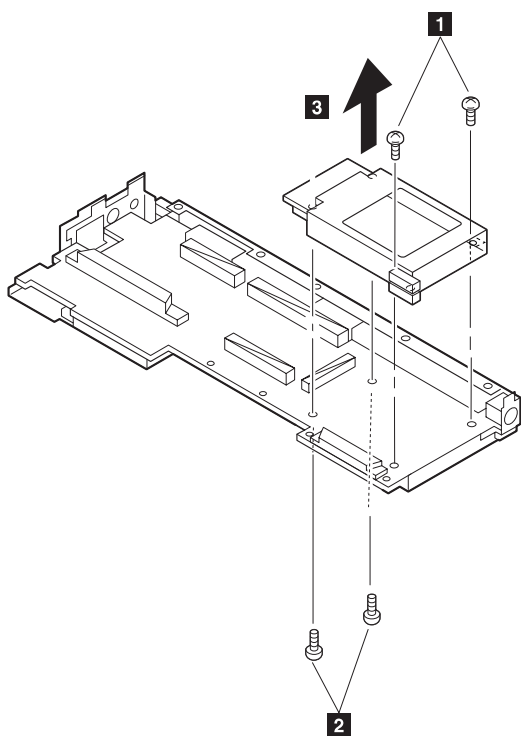

Notes:

1. When handling the PCMCIA slot assembly, be careful not to disassemble any part of it. The slot assembly is not solidly fixed when it is removed from the system board or the FRU.
In step **3**, gently pull up the bottom of the center area of the connector board edge with your fingers.
2. The screw stand at each corner of the PCMCIA slot is

easy to remove. Make sure that the screw stand is correctly positioned when the slot is replaced. Do not replace the slot without the screw stand.

Use the following table for reference when replacing parts.

Step	Location (Quantity)	Length
1	PCMCIA slot, upper (2)	4 mm
2	PCMCIA slot, lower (2)	14 mm
Note: Make sure you use the correct screw.		

2180 Processor Card

- CD-ROM Drive (2030)
- Battery Pack (2020)
- Hard Disk Drive (2040)
- Keyboard Unit (2080)
- Status Indicator (2090)
- Backup Battery (2110)
- Standby Battery and Front IR (2100)
- Logic Assembly (2115)

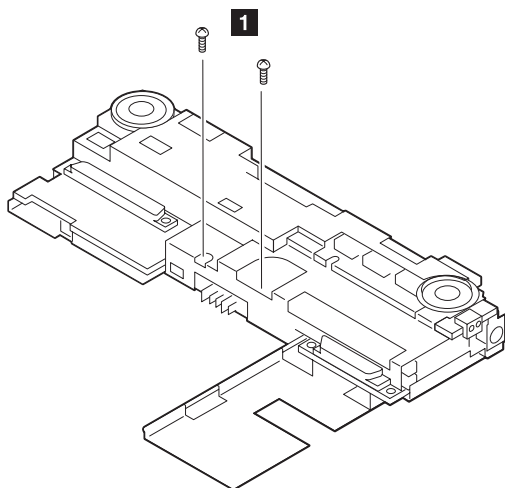

Turn the system board upside down. Then remove any metal tape holding the card.

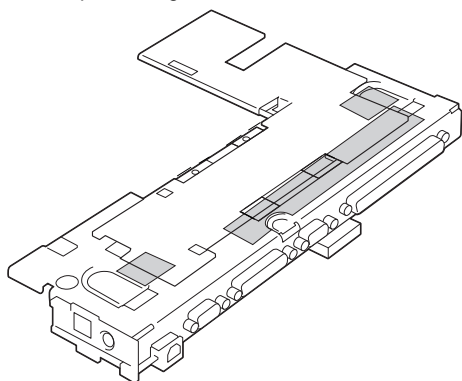

To remove the processor card, gently lift the area shown by **A** straight up. Do not pull the other areas.

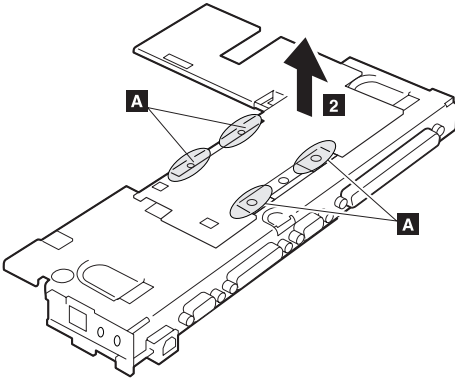

Note: If the processor card is not installed correctly, the computer may not turn on. Reinstall the card in this case.

Use the following table for reference when replacing parts.

Step	Location (Quantity)	Length
1	Processor card assembly	14 mm
Note: Make sure you use the correct screw.		

2190 LCD Assembly

- CD-ROM Drive (2030)
- Battery Pack (2020)
- Keyboard Unit (2080)
- Status Indicator (2090)

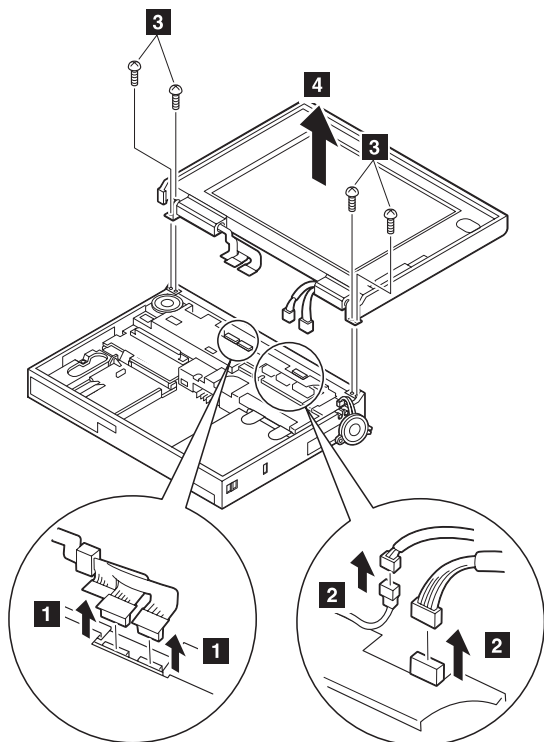

Note: When removing the LCD cables **1**, pull the connector straight up. Incorrect handling can damage the connector.

Use the following table for reference when replacing parts.

Step	Location (Quantity)	Length
3	LCD hinge (4)	4 mm

Note: Make sure you use the correct screw.

Safety Notice 5: Translation on page 11

If the LCD breaks and the fluid from inside the LCD gets into your eyes or on your hands, immediately wash the affected areas with water for at least 15 minutes. Seek medical care if any symptoms from the fluid are present after washing.

To Clean the LCD

Gently wipe the LCD with a dry, soft cloth. Do not use alcohol or detergent to clean the LCD.

To avoid damaging the LCD, do not scratch or apply any force to its surface.

2195 LCD Rear Cover (755CDV only)

Slightly push out and release the latches **1**.

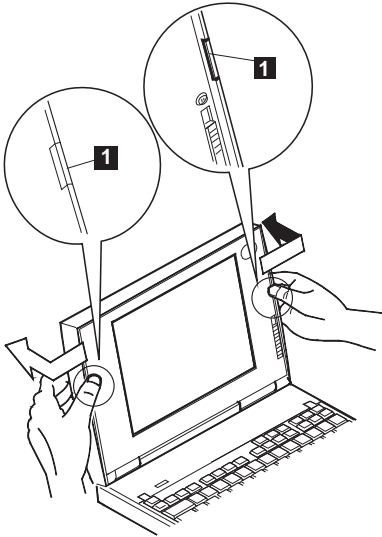

Note: Do not touch the film **2** on the rear cover while the cover is removed from the LCD.

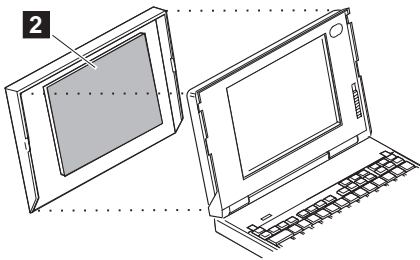

2200 Lower Shield Assembly

- CD-ROM Drive (2030)
- Battery Pack (2020)
- Hard Disk Drive (2040)
- Keyboard Unit (2080)
- Status Indicator (2090)
- Backup Battery (2110)
- Standby Battery and Front IR (2100)
- Logic Assembly (2115)
- Shield Assembly (2120)
- Video Card or Rear IR (2125)
- DC/DC Card (2130)
- DSP Card (2140)
- Interposer Card (2150)
- Processor Card (2180)
- System Board Assembly (2160)

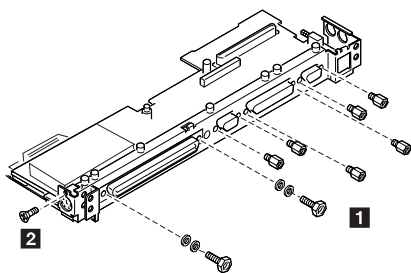

2210 Memory Card

- CD-ROM Drive (2030)
- Battery Pack (2020)
- Hard Disk Drive (2040)
- Keyboard Unit (2080)
- Status Indicator (2090)
- Backup Battery (2110)
- Standby Battery and Front IR (2100)
- Logic Assembly (2115)
- Shield Assembly (2120)
- Video Card or Rear IR (2125)
- DC/DC Card (2130)
- DSP Card (2140)
- Interposer Card (2150)
- Processor Card (2180)
- System Board Assembly (2160)
- Lower Shield Assembly (2200)

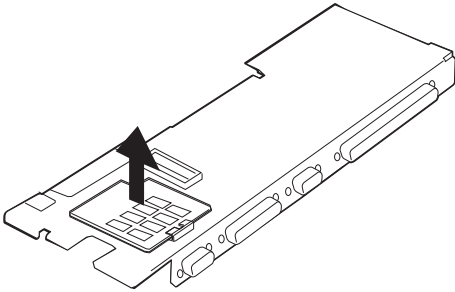

Note: If the computer does not complete POST after changing the memory card, reseal the card and try again.

Locations

Front View

- 1** LCD
- 2** Built-in Microphone
- 3** Brightness Control
- 4** Status Indicator
 - See "Status Indicators" on page 344.
- 5** External Input Device Connector
- 6** Video-In Port
- 7** Video-Out Port
- 8** PCMCIA Slot
- 9** Keyboard
- 10** LCD and Keyboard Latch
- 11** Click Button
- 12** CD-ROM Drive
- 13** Front Infrared Port
- 14** Fn Key
- 15** TrackPoint III
- 16** Volume Knob
- 17** Built-in Speaker

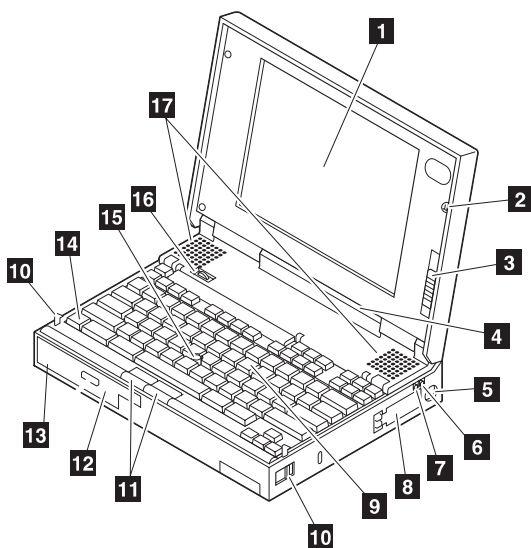

Rear View

- 1** Telephony Jack
- 2** Microphone/Line-In Jack
- 3** Headphone Jack
- 4** Power Switch
- 5** Power Jack
- 6** Serial Connector
- 7** Parallel Connector
- 8** External-Display Connector
- 9** Reset Switch
- 10** Game Port
- 11** System Expansion Connector

A multimedia portable expansion unit, port replicator, or port replicator with PCMCIA can be connected to this interface to support the following features.

- 16-bit AT-bus interface
- Serial port
- Parallel port
- Keyboard and mouse
- HDD connection
- LED control signals
- Visual signals
- Audio signals
- FDD signals
- PCMCIA signals
- Power controls
- Power line

- 12** Rear Infrared Port

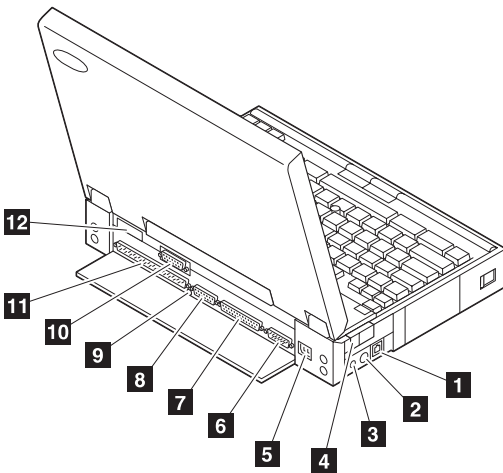

Parts Listing

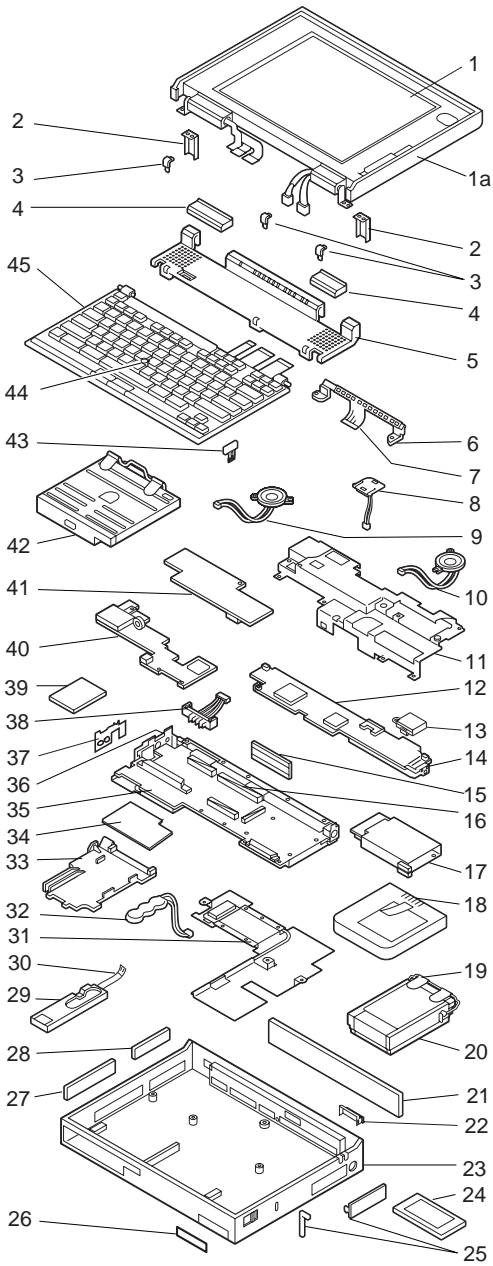

System Unit (755CD/755CDV)

Index Component

1	LCD Assembly (TFT)	85G1489
	LCD Assembly front (755CDV)	85G1633
	LCD Assembly rear cover (755CDV)	85G1630
2	Hinge Bracket, Right, Left	85G1894
3	Screw, Rubber Lid	85G1509
4	Hinge, Lid, Right/Left	85G1930
5	Top Cover (755CD)	85G1884
	Top Cover (755CDV)	85G7476
6	Stand-off, Indicator	85G1929
7	Status Indicator	85G1924
8	Backup Battery	85G1501
9	Speaker Assembly, Left	85G1931
10	Speaker Assembly, Right	85G1932
11	Shield Case, Upper	85G1887
12	Video Card Assembly	85G1885
13	IR Assembly, Rear	85G1936
	Junction FPC, IR Rear	85G1926
14	S-Video Card	85G1934
15	Interposer Card	85G1886
16	Lower Shield	85G1497
17	PCMCIA Slot Assembly	85G1062
18	Battery Pack (Ni-MH)	85G1510
19	HDD Removal Strap	66G5122
20	540MB Hard Disk Drive	84G4319
	810MB Hard Disk Drive	85G0961
21	Rear Connector Cover	85G1888
22	IR Lens, Rear	85G1925
23	Base Cover Assembly (755CD)	85G1881
	For Japan	85G1883
	Base Cover Assembly (755CDV)	85G1107
	For Japan	85G1108
24	PCMCIA Device (See options)	
25	PCMCIA Cover	85G1511
	(Includes bezels and security plate)	
26	Name Label	66G9228
27	Cover, Option Bay	85G1892
28	AV Door	84G6551
29	IR Lens, front	84G6548
30	IR Assembly, front	84G6549
31	Processor Card (33/100 MHz)	85G1495
32	Standby Battery	85G1039
33	Base Plate	84G6563
34	Memory Card	84G6561
35	System Board (755CD, 755CDV)	85G1141
36	Power Switch Button	85G1928
37	AV Panel	85G1927
38	Battery Terminal (755CD)	84G6556
	Battery Terminal (755CDV)	85G8568
39	IC DRAM Card (See options)	
40	DSP Card Assembly	85G8505
41	DC/DC Card (755CD with Intel 486)	85G1500
	DC/DC Card (755CD with Pentium, 755CDV)	85G8551
42	CD-ROM Drive	85G1914
43	Keyboard Security Plate	85G1895
44	TrackPoint III Cap	84G6536
45	Keyboard Assembly (See Keyboards)	
	Attachment Holder	
	Connection Cable, Microphone	85G8495

Index Component

Internal Microphone Cable	84G6559
Modem Connector Assembly, U.S.	85G1504
Modem Connector Assembly, EMEA	85G1505
Modem Connector Assembly, blank	85G6564
Wall Plug	85G2367
Head Phone	85G1529
PCMCIA Cartridge	84G1303
PCMCIA RF Cartridge	84G1304
Interface Cable, System - Keyboard	84G2531
Interface Cable, keyboard - Keypad	84G2532
Cable, Mini-DIN to Mini-DIN	84G6474
Keyboard Spacer	85G1937
Shield Case, Rear	85G1915
Conversion Cable - Game Port	85G1896
Conversion Cable - Video	85G1897
Rear FASCIA Panel	85G1919
Diskette Drive (4-mode)	66G5060
Diskette Drive (3-mode)	84G2269
Diskette Drive Removal Strap	66G5123
Bezel, Diskette Drive	85G1889
Foot (right, left)	84G4326
AC Adapter (35W, 3 pin)	85G4952
For Japan (2 pin)	85G6669
DC Plug (4 pin, 2 pin)	85G6664
Extension DC Cable (755CDV)	85G7466
DC Plug (4 pin, 2 pin)	85G6664
EMI Spring Plate	85G1066
DC Adapter Cable (755CV)	85G7466
Strap (755CDV)	85G1104
Computer Stand (755CDV)	85G1635
Remote Control (755CDV)	

Notes: The warranty for this component is provided by an outside company. See the warranty sheet supplied with this component. Call MindPath Technologies Inc.
12700 Park Central Drive Suite 1707
Dallas, Texas 75251
Tel. (214) 233-9296, 9308 (FAX)

Keyboard

Arabic	84G6508
Belgian	84G6506
Canadian French	84G6514
Danish	84G6505
Dutch	84G6503
French	84G6499
German (Black)	84G6497
Greek	84G6512
Hebrew	84G6509
Italian	84G6501
Japanese	84G6515
Latin American	84G6513
Norwegian	84G6507
Portuguese	84G6510
Spanish	84G6504
Swedish	84G6502
Swiss/French	84G6500
Swiss/German	84G6498
Turkish	84G6511
U.K. English	84G6496
U.S. English	84G6495

Common/Option Parts List

Miscellaneous Parts

Miscellaneous Parts Kit (Includes: modem guide; DC-in holder; spacer for video card; bracket for s-card; holder for s-card; modem lever; TV tuner label)	85G1933
Screw Kit (Includes: 20-2.5 x 6 mm; 10-2.5 x 4 mm; 20-2.5 x 8 mm; 10-2.5 nut; 10-hex stud bus; 10-washer bus; 10-spring lock washers; 10-2.5 x 8 mm (flat head); 10-2.6 x 5 mm (deform screw)	85G1935
IC DRAM CARD Eject Tape	53G9318

DAA Assembly

Austria	59G1041
Australia	59G1040
Belgium	43G3414
Denmark	59G1042
Finland	59G1043
France	4525652
Germany	59G1056
Korea	66X2096
Malaysia	59G1066
Netherlands	43G3409
Norway	59G1044
New Zealand	43G3411
PRC/Hong Kong	54F0693
Singapore	66X2096
Sweden	54F0717
Switzerland	59G1057
Taiwan	59G1067
Thailand	59G1064
U.K.	59G1045

PSTN Cable

Austria	58G4386
Australia	58G4343
Belgium	58G4346
Denmark	58G4333
Finland	58G4334
France	58G4335
Germany	58G4347
W/W	43G3398
Netherlands	58G4340
Norway	58G4334
New Zealand/PRC/Hongkong	58G4332
Sweden	58G4336
Switzerland	58G4348
U.K.	58G4345

Options

Notes:

1. When you replace the AC Adapter or the Quick Charger with a new one, use the one for the country you are in even if the system is from different country.
2. The warranty for the system unit does not apply to all options.

AC Adapter (40W)	49G2196
For Japan	49G2197
AC Adapter (100 - 125 V ac, 40W)	84G4320
For U.S. only.	
Audio Cable	66G5180
Battery Pack (Li-ion, for 755CDV)	85G8554
Car-Battery Adapter	49G1148
Small Car-Battery Adapter	84G4359
Diskette Drive Attachment Unit	66G5069
IC DRAM CARD 2MB	07G1414
IC DRAM CARD 4MB	07G1415
IC DRAM CARD 8MB	07G1416
IC DRAM CARD 16MB	66G0094
Microphone	66G7871
PS/2 Miniature Mouse	95F5723
Port Replicator	66G3575
Port Replicator with PCMCIA	66G3574
Travel Quick Charger (3-pin)	85G1530
Quick Charger Cable	85G1531
DIMM 4MB	84G4323
DIMM 8MB	84G6545
DIMM 16MB	84G4324
DIMM Adapter Card	84G4322
Headset	85G1529

Numeric Keypad

Belgian	95F5741
Canadian French	95F5466
Danish	95F5467
Dutch	95F5467
French	95F6313
German	95F6314
Greek	95F5467
Hebrew	95F5741
Icelandic	95F5467
Italian	95F6316
Japanese	79F6401
Norwegian	95F5467
Spanish	95F6315
Swedish/Finnish	95F5468
Swiss/French	95F5711
Swiss/German	95F5715
Turkish	95F5467
U.K. English	95F5741
U.S. English	95F5741

Black Keypad

French	84G6286
German	84G6280
Italian	84G6292
Swedish	84G6304
Norway	84G6310
U.K. English	84G6298
U.S. English	84G2530

Black Keyboard

French	84G6285
German	84G6279
Italian	84G6291
Swedish	84G6303
Norway	84G6309
U.K. English	84G6297
U.S. English	84G2529

Accessories (Models 755x)

Keyboard/Mouse Cable	54G0444
----------------------	---------

Tools

Tri-Connector Wrap Plug	72X8546
PC Test Card	35G4703
Audio Wrap Cable	66G5180
Screwdriver Kit	95F3598
ThinkPad 750Ce	82G3891
Hardware Maintenance Diskette (This diskette is common to all ThinkPad models.)	

Power Cords

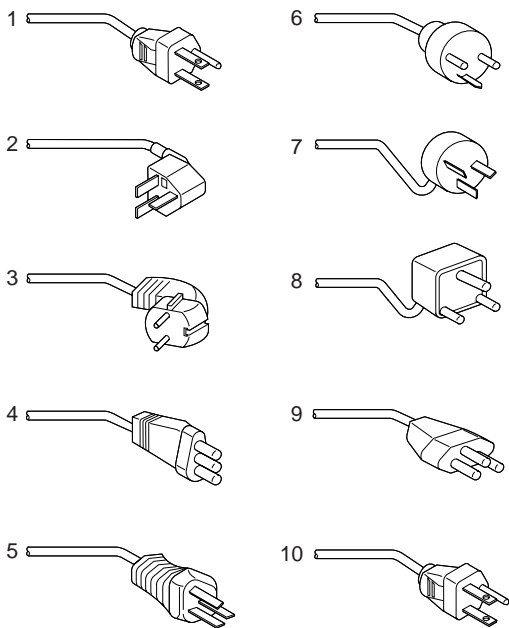

Warning: Use the power cord certified for your country.

	Country	30/40W	35W
1	Colombia, U.S., Venezuela	13F9959	25H2207
	Japan, 2-pin	6454377	85G6665
	Japan, 3-pin	65F0031	
2	Hong Kong, Singapore, U.K.	14F0033	25H2215
3	France, Germany, Spain	13F9979	25H2209
4	Italy	14F0069	25H2223
5	Australia, New Zealand	13F9940	25H2205
6	Denmark	13F9997	25H2211
7	Israel	14F0087	25H2225
8	Bangladesh, Pakistan, Sri Lanka, South Africa	14F0015	25H2213
9	Switzerland	14F0051	25H2221
10	Thailand	1838574	25H2219

Note: The 30/40W cord is 6 feet long; the 35W cord is 6 inches.

ThinkPad 755CE, 755CSE, 755CV, 755CX (9545)

General Checkout	393
Memory Checkout	393
System Board and Processor Card Checkout	395
Keyboard/Auxiliary Input Device Checkout	396
TrackPoint III Checkout	396
Diskette Drive Test	397
Power Systems Checkout	398
Power Management Features	405
Symptom-to-FRU Index	408
Numeric Error Codes	408
FRU Codes	411
Beep Symptoms	412
No Beep Symptoms	413
LCD Related Symptoms	413
Model 755CV Symptoms	414
Keyboard/TrackPoint III Related Symptoms	416
Indicator Related Symptoms	416
Power Related Symptoms	416
Function/Audio Related Symptoms	417
Peripheral Device Related Symptoms	417
Infrared Related Symptoms	418
Other Symptoms	418
Intermittent Problems	418
Undetermined Problems	419
Related Service Procedures	420
Status Indicators	420
How to Run the Diagnostics	421
Error Log	421
Reset Pushbutton	422
Checking the Installed Devices List	422
Password Combinations	422
How to Run the Low Level Format	423
PC Test Card LED	423
Fn Key Combinations	423
How To Run the Keyboard Diagnostics	424
Product Overview	424
FRU Removals and Replacements	426
1010 Rear Connector Door	427
1015 Foot	427
1020 Battery Pack	428
1030 Diskette Drive	429
1040 Hard Disk Drive	430
1050 IC DRAM Card or DIMM Adapter	431
1070 Diskette Drive Bezel	434
1080 Keyboard Unit	435
1090 Status Indicator	437
1100 Standby Battery and Front IR	438
1110 Backup Battery	439
1115 Logic Assembly	440
1120 Shield Assembly	442

1130 DC/DC Card	445
1140 DSP Card	446
1150 Interposer Card and Rear IR	447
1160 System Board Assembly	448
1170 PCMCIA Slot Assembly	449
1180 Processor Card	451
1190 LCD Assembly	453
1195 LCD Rear Cover (755CV only)	455
1200 Lower Shield Assembly	456
1210 Memory Card	457
Locations	458
Front View	458
Rear View	459
Parts Listing	460
Common/Option Parts List	464

General Checkout

Use the following procedure as a guide for computer problems.

Note: The diagnostic tests are intended to test only IBM products. Non-IBM products, prototype cards or modified options can give false errors and invalid system responses.

1. Obtain the failing symptoms in as much detail as possible.
2. Verify the symptoms by attempting to recreate the failure by running the diagnostic test or by repeating the same operation.

Note: To run the diagnostics, refer to “How to Run the Diagnostics” on page 421.

3. Use the following table with the verified symptom to determine which page to go to. Search the symptoms column and find the description that best matches your symptom; then go to the page shown in the “Go to” column.

Symptom	Go to
Power failure. (The power indicator does not go on or stay on.)	“Power Systems Checkout” on page 398.
POST does not complete. No beeps or error codes are indicated.	“Symptom-to-FRU Index” on page 408, and then use the No Beep Symptoms table.
POST beeps, but no error codes are displayed.	“Symptom-to-FRU Index” on page 408, and then use the Beep Symptoms table.
POST detected an error and displayed numeric error codes.	“Symptom-to-FRU Index” on page 408, and then use the Numeric Error Codes table.
The diagnostic test detected an error and displayed an FRU code.	“FRU Codes” on page 411.
The configuration is not the same as the installed devices.	“Checking the Installed Devices List” on page 422.
Other symptoms (such as LCD display problems).	“Symptom-to-FRU Index” on page 408, and then use the other symptoms table.
Symptoms cannot be recreated (intermittent problems).	Use the customer reported symptoms and go to “Symptom-to-FRU Index” on page 408.

Memory Checkout

One of two types of memory cards can be used, IC DRAM card or DIMM card. See the following table for the total memory size available when they are installed.

IC DRAM	Displayed Value
0 MB	7808 KB
2 MB	9856 KB
4 MB	11904 KB
8 MB	16000 KB
16 MB	24192 KB

DIMM	Displayed Value
0 MB	7808 KB
4 MB	11904 KB
8 MB	16000 KB
12 MB	20096 KB
16 MB	24192 KB
20 MB	28288 KB
24 MB	32384 KB
32 MB	40576 KB

Memory errors can stop system operations, show error messages on the screen, or hang the system. The computer detects memory parity errors but does not correct them.

Use the following procedure to isolate memory problems.

Notes:

- a. Except Model 755CX, installing a non-parity memory card causes memory errors. Before you go to the next procedure, check whether or not the memory card use parity or non-parity. If the non-parity memory card is installed, disable the parity check on the Easy-Setup configuration screen.
 - b. Make sure that the memory card is fully installed into the connector. A loose connection can cause an error.
1. Power-off the computer and remove the IC DRAM card, or DIMM card from its slot (if installed).
 2. Press and hold the F1 key; then power-on the computer. Hold the F1 key down until the Easy-Setup screen appears.
 3. Select **Test** and press enter.
 4. Select **Memory** and press enter to run the memory test on base memory. If an error appears, replace the memory card.
 5. Power-off the computer and reinstall the IC DRAM card or the DIMM card; then power-on the computer. Verify the memory size; then test the memory. If an error appears, replace the IC DRAM card or the DIMM card.

If memory problems occur intermittently, use the loop option to repeat the test. When the test detects an error, an error log is printed on the printer connected to the parallel port. See "Error Log" on page 421 for more information.

System Programs in Flash Memory: System setup programs and diagnostic tests are stored in Flash memory.

Flash Memory Update: A flash memory update is required for the following conditions:

- New versions of system programs.
- New feature or options are added.

When Updating Flash Memory

Do not power-off the computer, disconnect the Vac power, or remove the battery during the Flash update. The system board will have to be replaced if the update is interrupted.

Updating Flash memory also resets all of the customer's configuration settings to the default values.

To update the Flash memory, perform the following steps:

1. Get the appropriate diskette which contains the update.
2. Insert the **System Program Service Diskette** into drive A and power-on the computer.
3. Select **Update system programs** from the menu.

System Board and Processor Card Checkout

The processing functions are performed by both the system board and the processor card. Processor problems can be caused by either FRU. However, the processor card generally has a lower probability of failure. When a numeric code calls the system board or the processor card as a FRU, or the processor card is called by a diagnostic test by showing FRU code 11, use the following procedure to isolate the problem.

1. Run the system board test to verify the symptom. This test verifies both the system board and the processor card. If no error is detected, return to "General Checkout" on page 393.
2. If FRU code 10 appears, replace the system board but do not replace the processor card. Transfer the processor card from the old system board to the new system board.
3. If FRU code 11 appears, reseal the processor card.
4. Rerun the test to verify the fix.
5. If FRU code 11 remains, replace the processor card.

If above procedure does not correct the problem, go to “Undetermined Problems” on page 419.

Keyboard/Auxiliary Input Device Checkout

Remove the external keyboard if the internal keyboard is to be tested.

If the internal keyboard does not work or an unexpected character appears, make sure that the three flexible cables extending from the keyboard are correctly seated in the connectors on the interposer card.

If the keyboard cable connection is correct, run the **Keyboard Test** by doing the following:

1. Go to diagnostic menu screen by pressing **Ctrl+A** in the Easy-Setup screen.
2. Press **Ctrl+K**; a layout of the keyboard appears on the screen.
3. Check that when each key is pressed, the key position on the keyboard layout on the screen changes to a black square.

Note: When a Fn key is pressed, a black square briefly appears.

If the tests detect a keyboard problem, do the following one at a time to correct the problem. Do not replace a non-defective FRU.

- Reseat the three cables.
- Replace the keyboard.
- Replace the interposer card.
- Replace the system board.

The following auxiliary input devices are supported for this computer.

- Numeric keypad
- Mouse (PS/2 compatible)
- External keyboard (with keyboard/mouse cable)

If any of the above devices do not work, reseat the cable connector and repeat the failing operation.

If the problem does not occur again, recheck the connector.

If the problem is not corrected, replace the device, and then the system board.

TrackPoint III Checkout

If the TrackPoint III will not work, check the configuration in the Easy-Setup by selecting **Keyboard** from the **Config** menu. If the configuration of the TrackPoint III is disabled, select **Enable** to enable it.

If this does not correct the TrackPoint III problem, continue with the following.

The TrackPoint III does automatic compensations to adjust the pointer sensor. During this process, the pointer moves on the screen automatically for a short time. This self-acting pointer movement can occur when a slight, steady pressure is applied to the TrackPoint III pointer while the computer is powered on or while the system is running, or re-adjustment is required because the temperature has exceeded its normal temperature range. This symptom does not indicate a hardware problem. No service actions are necessary if the pointer movement stops in a short period of time.

If a click button problem or pointing stick problem occurs, do the following:

1. Go to the Easy-Setup screen.
2. Select an item with the pointing stick.
3. Press either the left or right click button.
4. Verify that both buttons work correctly.

If either the pointing stick or the click button will not work, do the following actions one at a time to correct the problem. Do not replace a non-defective FRU.

- Reseat the three keyboard cables.
- Replace the keyboard.
- Replace the interposer card.
- Replace the system board.

Diskette Drive Test

Do the following to isolate the problem to a controller, drive, or diskette. A scratch, write enabled, non-defective 2HD diskette is required.

Note: Make sure that the diskette does not have more than one label attached to it. Multiple labels can cause damage to the drive or can cause the drive to fail.

Do the following to select the test device:

1. Select the advanced diagnostic mode and select **Tool**, then select the icon **FDD-1** or **FDD-2** and press the space key. A ✓ mark appears next to the selected icon. Insert the **blank** diskette when instructed.
2. Run the diskette drive test.
3. If the controller test detects an error, FRU code 10 appears. Replace the system board.
4. If the controller test runs without errors, the drive read/write tests start automatically.
5. If the drive test detects an error, FRU code 50 for FDD-1 or 51 for FDD-2 appears. If the diskette itself is known to be good, replace the drive.
6. If the drive is attached through a Port Replicator as FDD-1 or FDD-2 and the test detects errors, move

the drive to the computer's diskette drive connector directly, and test it again as FDD-1.

If no errors occur at the FDD-1 position, the drive is not defective. Go to "Port Replicator Checkout" in "Common Devices Checkout" section to isolate the replicator problem.

7. If the drive is attached through an Expansion Unit, go to the service manual of the Expansion Unit to isolate the problem.
8. If the drive is attached through a Diskette Drive Attachment Unit, replace the unit.

Power Systems Checkout

To verify the symptom of the problem, power-on the computer using each of the power sources as follows.

1. Remove the battery pack, diskette drive, and hard disk drive.
2. Connect the AC Adapter and check that power is supplied.
3. Install the diskette drive, or hard disk drive one at a time and check that power is supplied from each power source.
4. Disconnect the AC Adapter, remove the hard disk and diskette drive, and install the charged battery pack; then check that power is supplied by battery pack.

If you suspect a power problem, see the appropriate power supply check listed below.

- "Checking the AC Adapter."
- "Checking Operational Charging" on page 399.
- "Checking the Battery Pack" on page 399.
- "Checking the Car-Battery Adapter" on page 402.
- "Checking the Travel Quick Charger" on page 403.
- "Checking the Backup Battery" on page 403.
- "Checking the Standby Battery" on page 403.
- "Port Replicator Power Overload" on page 407.

Checking the AC Adapter: You are here because the computer fails only when the AC Adapter is used.

- If the power problem occurs only when the port replicator is used, replace the replicator.
- If the power-on indicator does not turn on, check the power cord of the AC Adapter for correct continuity and installation.
- If the operational charge does not work, go to "Checking Operational Charging" on page 399.

Note: There are several types of adapters. The procedure for checking both types is the same.

1. Unplug the AC adapter cable from the computer and measure the output voltage at the plug of the AC adapter cable. See the following figure.

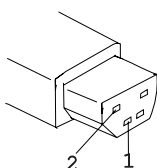

AC adapter (40W)

Pin	Voltage (V dc)
1	+18.0 to +21.0
2	Ground

AC adapter (35W)

Pin	Voltage (V dc)
1	+16.0 to +1.0/-0.5
2	Ground

- If the voltage is correct, replace the system board. If the problem is not corrected, go to “Undetermined Problems” on page 419.
 - If the voltage is not correct, go to the next step.
2. Unplug the AC Adapter cable from the ac power outlet and wait five minutes or longer to allow the over voltage protection circuit to be fully discharged and initialized.
 3. Plug the AC Adapter cable into the ac power outlet.
 4. Measure the output voltage of the AC Adapter.
 5. If the voltage is still not correct, replace the AC Adapter.

Note: An audible noise from the AC Adapter does not always indicate a defective adapter.

Checking Operational Charging: To check operational charging, use a discharged battery pack or a battery pack that shows a yellow or orange battery status indicator when it installed in the computer.

Perform operational charging. If the battery status indicator turns orange and the battery charging indicator turns green within two minutes, replace the AC Adapter.

Checking the Battery Pack: Battery charging will not start until the Fuel-Gauge shows that less than 90% of the total power remains; with this condition the battery pack will charge to 100% of its capacity. This protects the battery pack from being over-charged or having a shortened life.

Before you do the following steps, check the following:

- The correct battery pack is used for the model.
- The storage switch set to on (I).

1. Power-off the computer.

- Remove the battery pack and measure the voltage between battery terminals 1 (+) and 4 (-). See the following figure.

Ni-MH Battery Pack

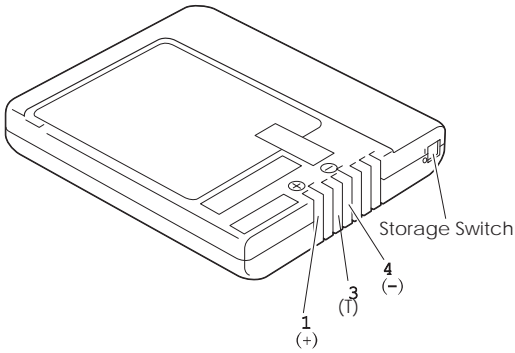

Terminal	Voltage (V dc) / Signal
1	+8.0 to +16.0
2	Send
3	Thermal
4	Ground (-)
5	NC
6	NC
7	NC

Li-Ion Battery Pack

Note: Li-ion battery is optional for Model 755CV and standard for Model 755CX.

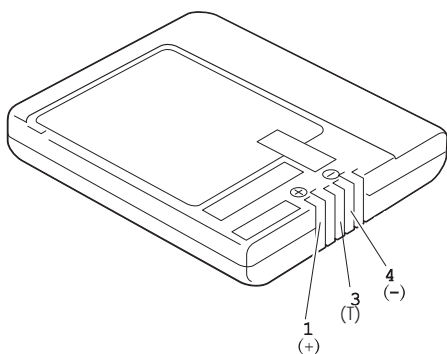

Terminal	Voltage (V dc) / Signal
1	+8.0 to +13.0
2	Send
3	Thermal
4	Ground (-)
5	Select (+)

Note: Signal lines, not used in these steps, are used for communication between the system and the battery. The storage switch is used to control the power to the internal microprocessor of the battery. The storage switch should be set to off (0) only when the battery is going to be kept in storage for more than two months.

3. If the voltage is less than +8.0 V dc, the battery pack has been discharged or is defective. Recharge the battery. If the recharging does not work, go to Step 5 to check the charging circuit.

If the voltage is still less than +8.0 V dc after the recharging, replace the battery.

4. If the voltage is more than +8.0 V dc, measure the resistance between battery terminals 3 and 4. The resistance must be 4 to 30 K ohm.

If the resistance is not correct, replace the battery pack.

If the resistance is correct, replace the DC/DC card.

5. To check the charging circuit, do the following.

Note: Be careful not to cause a short circuit. Plug in the AC Adapter with the battery pack removed, then power-on the computer.

6. Measure the charging voltage between DC/DC terminals 1 (+) and 4 (-).
7. If the voltage is less than +9.0 V dc, replace the DC/DC card. If the voltage is more than +9.0 V dc,

the charging circuit is working correctly, replace the battery pack.

Checking the Car-Battery Adapter

Note: There are several types of adapters but the checkout procedure is the same for both of them.

1. Unplug the Car-Battery Adapter cable from the computer.
2. Plug the Car-Battery Adapter into the cigarette lighter socket.

Note: If the adapter is already plugged in, reset it.

3. Measure the output voltage of the Car-Battery Adapter cable. See the following figure.

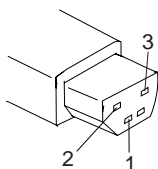

Pin	Voltage (V dc)
1	+19.0 to +21.0
2, 3	Ground

- If the voltage is correct and the power-on indicator on the Car-Battery Adapter is on all the time, the Car-Battery is working correctly. Replace the system board.

If the problem is not resolved when the system board is replaced, go to “Undetermined Problems” on page 419.

- If the voltage is outside the normal voltage range, do one of the following:
 - Try the above test procedures in a different car, if one is available.
 - Replace the Car-Battery Adapter if the computer works correctly with the AC Adapter.

Notes:

1. If the output voltage from the cigarette lighter socket of the car is less than 10.5 V dc, the power-on indicator on the Car-Battery Adapter blinks and a continuous noise can be heard. The condition of the car battery should be checked by appropriate service personal.
2. The Car-Battery Adapter does not support operational charging.

Checking the Travel Quick Charger

1. Ensure that the battery pack is operating correctly. (See “Checking the Battery Pack” on page 399.)
2. Connect the power cord to the Travel Quick Charger and the other end to an ac power outlet. Ensure that the power-on indicator is on.
 - If the power-on indicator does not turn on, check the power cord for correct continuity and installation.
 - If the problem is not corrected, replace the Travel Quick Charger or the power cord.
3. Install the battery pack into the Travel Quick Charger.
 - If the charging indicator does not start blinking, replace the Travel Quick Charger.

Checking the Backup Battery

1. Power-off the computer and unplug the AC Adapter from the computer.
2. Open the keyboard, and remove the battery pack.
3. Remove the backup battery from the shield assembly.
4. Measure the voltage of the backup battery. See the following figure.

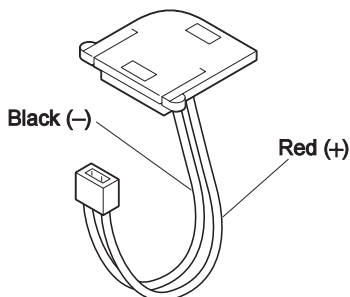

Wire	Voltage (V dc)
Red	+2.5 to +3.7
Black	Ground

- If the voltage is correct, replace the system board.
- If the voltage is not correct, the backup battery has been discharged. Replace the backup battery.
- If the backup battery discharges quickly after replacement, replace the system board.

Checking the Standby Battery

1. Power-off the computer and unplug the AC Adapter from the computer.
2. Open the keyboard, and remove the battery pack and the diskette drive.

3. Remove the standby battery. (Refer to “1100 Standby Battery and Front IR” on page 438 to remove the battery.)
4. Measure the voltage of the standby battery.
 - If the voltage between red and black is 3.5 V dc or greater, the voltage is correct. Go to Step 10 to verify standby battery operation.
 - If the voltage is less than 3.5 V dc, go to the next step.
5. Plug the AC Adapter into the computer and power-on the computer.
6. Measure the output voltage at the connector on the system board.

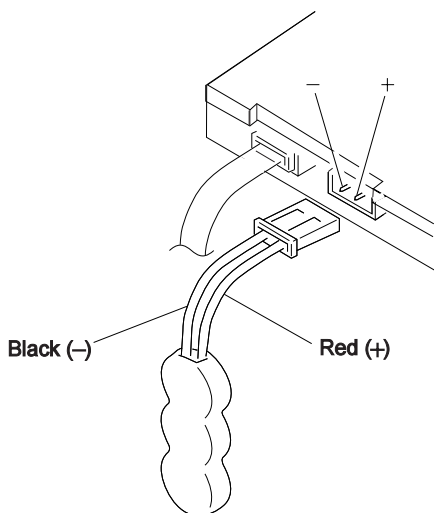

Pin	Voltage (V dc)
+	+4.0
-	Ground

- If the voltage is less than +4.0 V dc, replace the DC/DC card. If the voltage is still low, replace the system board.
 - If the voltage is more than +4.0 V dc, power-off the computer, replace the standby battery, and go to the next step.
7. Ensure that the AC Adapter is plugged into the computer; then power-on the computer.
 8. Charging of the standby battery starts. A depleted battery needs approximately 30 minutes to be recharged to the operational voltage of +3.5 V dc.
 9. Unplug the AC Adapter.
 10. Verify the standby battery function by removing and installing the battery pack during suspend mode.

Note: Removing and installing the battery pack during suspend mode should be done within one minute. The resume operation must start. If the resume operation does not work, switching of power from the battery pack to standby battery will not be correct. Replace the DC/DC card.

If replacing the DC/DC card does not resolve the problem, replace the system board.

Power Management Features

Three power management modes are provided by the computer to save power consumption and prolong battery power.

Standby Mode: When in standby mode the following occurs:

- The LCD backlight turns off.
- The hard disk motor stops.

Events that cause the computer to enter the standby mode.

- Standby requested by the Fn key. (Fn+F3)
- No activity under **auto-standby** enabled by the feature utility.

Events that cause the computer to exit the standby mode (resume).

- Any key operation.

Suspend Mode: When in suspend mode, the following occur:

- The LCD backlight turns off.
- The LCD power is powered-off.
- The hard disk is powered-off.
- The CPU is stopped.

In the ThinkPad Features Program, the computer can be set to "Will not suspend even if LCD is closed."

When the computer is powered with ac power and is used with one of the following IBM PC cards, the computer can enter the *standby mode* only. The PC card and application program remain active.

- 3270 Emulation Credit Card Adapter
- 5250 Emulation Credit Card Adapter
- Token-Ring 16/4 Credit Card Adapter
- Credit Card Adapter for Ethernet

Events that prevent the computer from entering the suspend mode.

- While the communication link is running.
- When a pointing device (except a serial mouse) are selected in the **Config** menu of the Easy-Setup.

Events that cause the computer to enter the suspend mode.

- Suspend mode is requested by pressing the Fn key (Fn+F4).
- The LCD is closed.
- The keyboard is opened.
- The specified time has elapsed from the last operation with the keyboard, mouse, hard disk drive, parallel connector, diskette drive, or the AC Adapter is plugged in. The time is specified by **Suspend Timer** in the ThinkPad Features program.
- The battery condition is low. The battery power indicator blinks (orange).
- The *PS2 OFF* command is set in the ThinkPad Features program.

Events that cause the computer to exit the suspend mode (resume or hibernate).

- (Resume) The LCD is opened.
- (Resume) The keyboard is closed.
- (Resume) Real time clock alarm signaled.
- (Resume) Ring indicator (RI) signaled by serial or PCMCIA device.
- (Resume) The Fn key is pressed.
- (Hibernate) Timer conditions are satisfied to enter the hibernation mode.

Hibernation Mode: When in hibernation mode, the following occurs.

- The system status, RAM, VRAM, and setup data are stored on the hard disk.
- The system is powered-off.

The computer cannot enter the hibernation mode if the computer is powered with ac power and one of the following IBM PC cards is used.

- PCMCIA Data/FAX Modem
- High Speed PCMCIA Data/FAX Modem
- 3270 Emulation Credit Card Adapter
- 5250 Emulation Credit Card Adapter
- Token-Ring 16/4 Credit Card Adapter
- Credit Card Adapter for Ethernet

Events that cause the computer to enter the hibernation mode:

- The hibernation mode is requested by the Fn key (Fn+F12).
- Timer conditions are satisfied in suspend mode.
- Critical low battery condition.

Event that cause the computer to exit the hibernation mode.

- The power-on switch is operated.

When power is turned on, the hibernation history of the boot record on the hard disk is recognized and system status is restored from the hard disk to resume operation.

Port Replicator Power Overload: If intermittent power shut-downs occur while using two or more PCMCIA devices with a port replicator, suspect an over-current problem. Some PCMCIA devices use more than the recommended maximum power. If the maximum usage for each device occurs simultaneously, the total current can exceed the replicator power limit, thereby causing a power shut down. Isolate this problem by removing one of the devices and using the computer under the same condition to see whether a power shut down occurs. Do this procedure for all devices, then determine the cause.

Symptom-to-FRU Index

The Symptom-to-FRU Index lists the symptoms and errors and the possible causes. The most likely cause is listed first.

Note: Perform the FRU replacement or actions in the sequence shown in the “FRU/Action” columns. If a FRU did not solve the problem, put the original part back in the computer. Do not replace a non-defective FRU.

This index can also be used to help you decide which FRUs to have available when servicing a computer.

Numeric error codes show the errors detected in POST or system operation. In the following error codes, **X** can be any number.

If no codes are available, use narrative symptoms.

If the symptom is not listed, go to “Undetermined Problems” on page 419.

Note: For IBM devices not supported by diagnostic codes of the ThinkPad computers, see the manual for that device.

Numeric Error Codes

Symptom/Error	FRU/Action
10X	1. System Board
110	1. Go to “Memory Checkout” on page 393. 2. IC DRAM Card or DIMM Card 3. System Board
111	1. Go to “Memory Checkout” on page 393. 2. Expansion Unit/Port Replicator 3. System Board
158 (HDP was not set even though the supervisor password is set.)	1. Set a HDP.
159 (HDP is not set the same as the supervisor password.)	1. Set a correct HDP.
161	1. Go to “Checking the Backup Battery” on page 403. 2. Backup Battery 3. System Board
163 (Time and Date was not set.)	1. Set Time and Date. 2. System Board

Symptom/Error	FRU/Action
173 (Configuration data were lost.)	<ol style="list-style-type: none"> 1. Select OK in the error screen; then set time and date. 2. Backup Battery 3. System Board
174 (Perform "Checking the Installed Devices List" on page 422 before changing any FRUs.)	<ol style="list-style-type: none"> 1. Check Device Configuration. 2. System Board 3. Diskette Drive Assembly 4. Hard Disk Drive Assembly
175, 177, 178	<ol style="list-style-type: none"> 1. System Board
183 (Incorrect password entered at the supervisor password prompt.)	<ol style="list-style-type: none"> 1. Have the user examine the password.
184 (POP check sum error.)	<ol style="list-style-type: none"> 1. Reset the POP in the Easy-Setup.
185 (The startup sequence is not valid. Suspect that power was off when the startup sequence was being updated.)	<ol style="list-style-type: none"> 1. Reset the startup sequence in the Easy-Setup.
186	<ol style="list-style-type: none"> 1. System Board
188	<ol style="list-style-type: none"> 1. Set the system identification using the ThinkPad 750Ce hardware maintenance diskette.
190 (Depleted battery pack was installed when the power was on.)	<ol style="list-style-type: none"> 1. Go to "Checking the Battery Pack" on page 399.
191XX	<ol style="list-style-type: none"> 1. System Board 2. Processor card
196 (Read error occurred in the hibernation area of the HDD.)	<ol style="list-style-type: none"> 1. Run the hard disk drive test. 2. Hard Disk Drive
199XX	<ol style="list-style-type: none"> 1. System Board
1XX	<ol style="list-style-type: none"> 1. System Board
2XX	<ol style="list-style-type: none"> 1. Go to "Memory Checkout" on page 393. 2. IC DRAM Card, DIMM, or DIMM Adapter 3. System Board

Symptom/Error	FRU/Action
301, 303, 304, 305, 3XX	<ol style="list-style-type: none"> 1. Go to “Keyboard/Auxiliary Input Device Checkout” on page 396. 2. Keyboard 3. Video Card 4. External Numeric Keypad 5. External Keyboard 6. Keyboard/Mouse Cable 7. System Board
601, 6XX	<ol style="list-style-type: none"> 1. Go to “Diskette Drive Test” on page 397. 2. Diskette Drive Assembly 3. Diskette 4. System Board
602 (Diskette read error.)	<ol style="list-style-type: none"> 1. Go to “Diskette Drive Test” on page 397. 2. Diskette 3. Diskette Drive Assembly
604 (Non-acceptable ID was read from the diskette drive.)	<ol style="list-style-type: none"> 1. Go to “Diskette Drive Test” on page 397. 2. Diskette Drive Assembly 3. System Board
11XX	<ol style="list-style-type: none"> 1. Serial Device (First) 2. Communication Cable 3. System Board
12XX	<ol style="list-style-type: none"> 1. Serial Device (Second) 2. Communication Cable 3. System Board
17XX	<ol style="list-style-type: none"> 1. Hard Disk Drive 2. System Board
24XX	<ol style="list-style-type: none"> 1. System Board
4101	<ol style="list-style-type: none"> 1. Reseat the LCD connector (Pen, see “1190 LCD Assembly” on page 453). 2. LCD Assembly 3. System Board
808X	<ol style="list-style-type: none"> 1. PCMCIA Slot Assembly 2. PCMCIA Device 3. System Board
860X (Pointing device error when TrackPoint III is disabled.)	<ol style="list-style-type: none"> 1. External Mouse 2. External Keyboard 3. System Board

Symptom/Error	FRU/Action
861X (Pointing device error when TrackPoint III is enabled.)	<ol style="list-style-type: none"> Reseat the keyboard Track Point III cable at the E-Video card. See "1080 Keyboard Unit" on page 435. Keyboard External Mouse System Board
I9990301 I9990302 I9990305	<ol style="list-style-type: none"> Reseat the boot device. Check the startup sequence for the correct boot device. Check that operating system has no failure, or is installed correctly.
I9990303	<ol style="list-style-type: none"> System Board
Other codes not listed above	<ol style="list-style-type: none"> Go to "Undetermined Problems" on page 419.

FRU Codes

If an error is detected by the diagnostic tests, a *four-digit* FRU code is displayed. The FRU code indicates two suspected FRUs. Replace the FRU that is indicated by the *two leftmost digits* first, then replace the FRU indicated by the *two rightmost digits*. No FRU is assigned to code 00. If only one FRU is suspected, the other FRU code is filled with zeros. See the referenced page before replacing the FRU.

FRU Code	FRU/Action
10	System Board
11	Processor Card
16	DSP Card
17	Front IR Unit
18	Rear IR Unit
20	Memory (See "Memory Checkout" on page 393.)
30	Reserved
32	External Keyboard
33	External Mouse
40	LCD Assembly
45	External CRT
50	<ol style="list-style-type: none"> Reseat the Drive (FDD-1) Diskette Drive (FDD-1)
51	<ol style="list-style-type: none"> Reseat the Drive (FDD-2) Diskette Drive (FDD-2)

FRU Code	FRU/Action
60	<ol style="list-style-type: none"> 1. Reseat the Hard Disk Drive (HDD-1) 2. Hard Disk Drive (HDD-1)
61	<ol style="list-style-type: none"> 1. Reseat the Hard Disk Drive (HDD-2) 2. Hard Disk Drive (HDD-2)
70	PCMCIA-2 (Replicator)
71	PCMCIA (in FDD compartment)
80	Cellular Modem

Note: The device ID and error codes are used to indicate the detail portion of the FRU that caused the error. If replacing a FRU does not correct a problem, see the Device ID or error code from the previous failure. If they have changed, the cause might be that the new FRU is defective or that the FRU was incorrectly installed.

If the problem remains after replacement of the FRUs, go to “Undetermined Problems” on page 419.

Beep Symptoms

Symptom/Error	FRU/Action
Continuous beeps.	System Board
One beep and a blank, unreadable, or flashing LCD.	<ol style="list-style-type: none"> 1. Reseat all LCD connectors. 2. LCD Assembly 3. System Board 4. DC/DC Card
One beep, and the message “Unable to access boot source.”	<ol style="list-style-type: none"> 1. Boot device 2. System Board
One long, two short beeps and a blank or unreadable LCD.	<ol style="list-style-type: none"> 1. System Board 2. LCD Assembly
One long beep followed by four short beeps each time the power switch is operated. (System cannot power-on due to low battery voltage.)	Connect the AC Adapter or install a fully-charged battery.
One beep every second. (System is shutting down due to low battery voltage.)	Connect the AC Adapter or install a fully-charged battery (allows system to complete shutdown before changing the battery).
Two short beeps with error codes.	POST error. See “Numeric Error Codes” on page 408.
Two short beeps with blank screen.	System Board

No Beep Symptoms

Symptom/Error	FRU/Action
No beep, power-on indicator not on, and a blank LCD during POST.	<ol style="list-style-type: none"> 1. Go to “Power Systems Checkout” on page 398. 2. System Board 3. DC/DC Card 4. Power sources
No beep, power-on indicator on, and a blank LCD during POST.	<ol style="list-style-type: none"> 1. System Board 2. DC/DC Card 3. Processor Card
No beep, power-on indicator on, and a blinking cursor only during POST.	<ol style="list-style-type: none"> 1. System Board 2. Processor Card 3. DC/DC Card
No beep during POST but system runs correctly.	<ol style="list-style-type: none"> 1. Turn the volume up and check the speaker 2. Speaker 3. DSP Card 4. DC/DC Card

LCD Related Symptoms

The TFT LCD for the notebook computer contains over 921 000 thin film transistors (TFTs). A small number of missing, discolored or lighted dots (on all the time) is characteristic of TFT LCD technology, but excessive pixel problems can cause viewing concerns.

The LCD should be replaced if the number of dots satisfies the following condition.

- The number of missing, discolored, or lighted dots in any colored background is 21 or more.

Note: For Model 755CV, see also “Model 755CV Symptoms” on page 414 for LCD related symptoms.

Symptom/Error	FRU/Action
No beep, power-on indicator on, and a blank LCD during POST.	<ol style="list-style-type: none"> 1. System Board 2. DC/DC Card 3. Processor Card
<ul style="list-style-type: none"> • LCD backlight not working, or • LCD too dark, or • LCD brightness cannot be adjusted, or • LCD contrast cannot be adjusted. 	<ol style="list-style-type: none"> 1. Reseat the LCD connectors. 2. LCD Assembly 3. Interposer Card 4. DC/DC Card

Symptom/Error	FRU/Action
<ul style="list-style-type: none"> LCD screen unreadable, or Characters missing pels, or Screen abnormal, or Wrong color displayed. 	<ol style="list-style-type: none"> See note for “LCD Related Symptoms.” Reseat all LCD connectors LCD Assembly System Board Interposer Card
LCD has extra horizontal or vertical lines displayed.	LCD Assembly

Model 755CV Symptoms

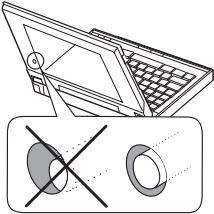
Symptom/Error	FRU/Action
The screen is black when the LCD cover is installed.	<ol style="list-style-type: none"> Verify that the LCD cover is firmly installed on the LCD. Diagnose the LCD assembly by following “LCD Related Symptoms” on page 413.
The LCD is wavy when the computer is placed on the overhead projector.	Some overhead projectors interfere with the LCD of the computer. Use another overhead projector.
The LCD stays on even when the LCD cover is removed.	<p>Make sure that the switch on the rear of the LCD is not stuck. If it is stuck, release it with the tip of a ball-point pen.</p> 
<ul style="list-style-type: none"> Abnormal screen Uneven color on the screen Spot on the screen 	<ol style="list-style-type: none"> Check that the white film on the LCD cover is clean. Gently wipe the film with a dry, soft cloth, such as a lens cleaner. LCD Cover Diagnose the LCD assembly by following “LCD Related Symptoms” on page 413. <p>Note: The customer may be responsible for repair costs if the LCD cover was damaged due to misuse, excessive force, scratch, or liquid spilled by the customer.</p>
The computer has an intermittent problem when you use it on the overhead projector.	Problem such as high environmental temperature might be the cause. Use the stand supplied with the computer.

Symptom/Error	FRU/Action
<p>The remote control does not work.</p>	<ol style="list-style-type: none"> 1. Check that two AAA alkaline batteries are installed in the remote control. 2. Check that two AAA alkaline batteries in the remote control are at their normal energy (voltage) level. 3. Enable the IR port of the computer with the ThinkPad Features program. (Disable the serial port at this time.) 4. Refer to the trouble shooting section in the Help menu of the Mind Path Presentation F/X program. Set up this program following the guide. 5. If the preceding items are correct, the radiation from the light of the overhead projector might be interfering the IR port of the computer. Disable the rear IR port of the computer, and use the remote control with the front IR port. 6. Use the remote control with another computer, which IR port works normally. If the remote control does not work, the remote control is not working properly. <p>If there is still a problem, refer to "Infrared Related Symptoms" on page 418.</p>

Keyboard/TrackPoint III Related Symptoms

Symptom/Error	FRU/Action
Keyboard (one or more keys) does not work.	<ol style="list-style-type: none"> 1. Reseat the three keyboard cables. 2. Keyboard 3. Interposer Card 4. System Board
TrackPoint III does not work.	<ol style="list-style-type: none"> 1. Go to “TrackPoint III Checkout” on page 396. 2. Keyboard 3. Interposer Card 4. System Board
Pointer moves automatically or does not work correctly.	<ol style="list-style-type: none"> 1. See “TrackPoint III Checkout” on page 396.

Indicator Related Symptoms

Symptom/Error	FRU/Action
Indicator incorrectly remains off or on, but system runs correctly.	<ol style="list-style-type: none"> 1. Reseat the status indicator cable. 2. Status Indicator 3. Interposer Card 4. System Board
Battery power status indicator blinks from green, yellow, to orange.	<ol style="list-style-type: none"> 1. Check that a correct battery is installed. 2. Set the battery storage switch to ON. 3. Battery Pack 4. DC/DC Card 5. System Board

Power Related Symptoms

Symptom/Error	FRU/Action
Power shut down during operation.	<ol style="list-style-type: none"> 1. Go to “Power Systems Checkout” on page 398. 2. Battery Pack 3. Remove the battery pack and let it cool for two hours. 4. DC/DC Card 5. Power sources
The system will not power-off. (See “Reset Pushbutton” on page 422.)	<ol style="list-style-type: none"> 1. Press the Reset pushbutton. 2. System Board

Function/Audio Related Symptoms

Symptom/Error	FRU/Action
The system will not suspend or resume by opening or closing the keyboard.	<ol style="list-style-type: none"> 1. Go to “Suspend Mode” on page 405 and check that the computer can enter suspend mode. 2. DC/DC Card 3. Interposer Card 4. System Board
The system will not suspend or resume by opening or closing the LCD.	<ol style="list-style-type: none"> 1. Go to “Suspend Mode” on page 405 and that check that the computer can enter suspend mode. 2. Interposer Card 3. DC/DC Card 4. System Board
Battery Fuel-Gauge does not go higher than 90%.	Go to “Checking the Battery Pack” on page 399 and see the note.
Memory count (size) appears differently from actual size.	Go to “Memory Checkout” on page 393.
System configuration does not match the installed devices.	Go to “Checking the Installed Devices List” on page 422.
System hangs intermittently.	Go to “Intermittent Problems” on page 418.

Peripheral Device Related Symptoms

Symptom/Error	FRU/Action
External display does not work correctly.	<ol style="list-style-type: none"> 1. See “External Display Self-Test” in “Common Devices Checkout” section.
Printer problems.	<ol style="list-style-type: none"> 1. Run Printer Self-test. 2. System Board 3. Parallel Port Device 4. Cable
Serial or parallel port device problems.	<ol style="list-style-type: none"> 1. Device 2. Device Cable 3. System Board

Infrared Related Symptoms

Symptom/Error	FRU/Action
Unable to communicate using the Infrared (IR) Port.	<ol style="list-style-type: none">1. Make sure the setup for the IR is correct.2. Make sure there are no fluorescent lights near the computer. The computer may receive electrical noise from the fluorescent light.3. Run the advanced diagnostic test. If an error occurs and a FRU code is displayed, replace the parts shown by the FRU code.4. For Model 755CV, if the remote control is enabled, the communication with the IR port is disabled. Run the Mind Path Presentation F/X program and set the infrared to OFF; then observe the symptom.

Other Symptoms

Symptom/Error	FRU/Action
Errors occur only when Port Replicator is used.	See “Port Replicator Checkout” in “Common Devices Checkout” section.
PCMCIA slot pin is damaged.	PCMCIA Slots Assembly

Note: If you cannot find a symptom or error in this list and the problem remains, see “Undetermined Problems” on page 419.

Intermittent Problems

Intermittent system hang problems can be caused by a variety of reasons that have nothing to do with a hardware defect such as: cosmic radiation, electrostatic discharge, or software errors. FRUs replacement should only be considered when a recurring problems exits.

When analyzing the intermittent problem, do the following:

1. Run the advanced diagnostic test for the system board in loop mode at least 10 times.
2. If no error is detected, do **not** replace any FRUs.

3. If any error is detected, replace the FRU shown by the FRU code. Rerun the test to verify that no more errors exist.

Undetermined Problems

You are here because the diagnostic tests did not identify which adapter or device failed, installed devices are incorrect, a short circuit is suspected, or the system is inoperative. Follow the procedures below to isolate the failing FRU (do not isolate non-defective FRUs).

Verify that all attached devices are supported by the computers.

Verify that the power supply being used at the time of the failure is operating correctly. (See "Power Systems Checkout" on page 398.)

1. Power-off the computer.
2. Check the cables, wires, and connectors for short circuits and open circuits. Visually check them for damage. If any problems are found, replace the FRU.
3. Remove or disconnect all of the following devices.
 - a. Non-IBM devices
 - b. Devices attached to the expansion bus connector
 - c. Printer, mouse, and other external devices
 - d. Battery pack
 - e. Hard disk drive
 - f. Diskette drive or the device attached to the diskette drive connector
 - g. IC DRAM card or DIMM card
 - h. PC Cards

Note: Remember that removing the hard disk drive, an IC DRAM card, or any adapter or device, might cause configuration errors. Ignore error code 174.

4. Power-on the computer.
5. Determine if the problem has changed.
6. If the problem does not occur again, reconnect the removed devices one at a time until you find the failing FRU.
7. If the problem remains, replace the following FRUs one at a time. Do not replace a non-defective FRU.
 - DC/DC card
 - Interposer card
 - LCD assembly
 - System board
 - Processor card











Related Service Procedures



This section provides information about the following:

- “Status Indicators”
- “How to Run the Diagnostics” on page 421
- “Error Log” on page 421
- “Checking the Installed Devices List” on page 422
- “Password Combinations” on page 422
- “How to Run the Low Level Format” on page 423
- “PC Test Card LED” on page 423
- “Fn Key Combinations” on page 423
- “How To Run the Keyboard Diagnostics” on page 424

Status Indicators

The system status indicators show the current computer status in different colors (green, yellow, and orange).

Symbol	Color	Meaning
	Blinking green	Speaker sounds
	Green	Battery fully charged
	Yellow	Battery usable
	Orange	Battery low, or if  is green, the operational charge cannot be performed.
	Blinking orange	Battery almost depleted
	All blinking	Battery storage switch is set off
	Orange, green, or yellow	if  is blinking twice every 3 seconds, the battery is discharging.
	Green	Battery charging
	Orange	PC card in-use
	Orange	Diskette drive in-use
	Orange	Hard disk drive in-use
	Green	Keys in Num Lock mode
	Green	Keys in Caps Lock mode
	Green	Keys in Scroll Lock mode

Symbol	Color	Meaning
	Green	Computer in suspend mode
	Blinking green	Computer resuming normal mode
	Green	Computer powered on

How to Run the Diagnostics

Use either the TrackPoint III or the cursor move keys to interact with the tests. The Enter key works the same as selecting the OK icon to reply OK.

1. Press and hold the F1 key; then power-on the computer. Hold the F1 key down until the Easy-setup screen appears.
 2. Select **Test** and press Enter.
 3. Select a device and press Enter to run the test. To test the Infrared port, select the "SystemBoard" icon.
 4. The test progress screen appears.
 5. **OK** appears when the test ends without any errors.
 6. Start the **Advanced Diagnostic test** by pressing **Ctrl+A** on the basic diagnostic menu screen.
 7. Select **Tool** to install the tools.
 8. Select a device, press the **space** key, and install the tool. Multiple devices can be selected by repeating this step.
- A √ mark appears for the selected device.
9. Select **OK** and press Enter if the selection is OK.
 10. Select a device and press Enter to start the tests.
 11. Select **Test All** to test all devices.
 12. Select **Loop Test** to loop tests.

A loop option menu appears in which a device loop or all loop can be selected. Select a device and press the **space** key to select a device. Repeat this step to select multiple devices. Press Enter to start the diagnostic loop. If no device is selected, all device tests are looped.

13. To exit the loop, keep pressing **Ctrl+Pause** until the test exits. A beep sounds to notify that the exit interrupt is sensed by the test program.

Error Log

Diagnostic errors are printed on the printer that is attached to the parallel port when the error is detected. The error is also logged in the system memory.

Do the following to display the errors.

1. End the test, if it is running.
2. Press **Ctrl+A** to select the advanced diagnostic mode.
3. Press **Ctrl+E**.

4. The error log appears.
5. To exit the screen, select the cancel icon or press Esc.

The error log is not saved when system power is powered-off.

Reset Pushbutton

The reset pushbutton resets the system and forces the power to be powered-off . Use this pushbutton when the power is not completely off or the system is hung. See “Rear View” on page 459 for the location of the pushbutton.

Checking the Installed Devices List

If a device is installed but the icon appears in a gray shade rather than a dark shade on the basic diagnostics screen, the device is defective. Reseat the device connectors. If the symptom remains, replace the device or the system board. If needed, adjust the contrast control to clearly distinguish the shades of the icon.

If a device that is not installed appears in a dark shade, for example, FDD-2 appears in a dark shade when *NO* second FDD is installed, do the following.

1. Replace the **first** device, such as a FDD-1, HDD-1, or PCMCIA-1.
2. If the problem remains, replace the system board.

PCMCIA-1, Parallel, and Serial icons are always displayed in dark shade, because the icons represent subsystems of the system board and not attachment of the devices.

The HDD-1, FDD-1, or PCMCIA-1 represents the **first** drive in the system configuration, respectively. Similarly, the HDD-2, FDD-2, or PCMCIA-2 represents the **second** drive, usually attached through a port replicator or an expansion unit.

Password Combinations

The password relationship is:

- ***When POP is the same as HDP***
The POP prompt appears, but the HDP prompt does not appear.
- ***When POP is not the same as HDP***
Both POP and HDP prompts appear.
- ***PAP and HDP***
When PAP is used, the HDP is enabled automatically, but no HDP prompt appears. The HDP is set the same as PAP.

How to Run the Low Level Format

Do the following to format the hard disk.

Note: Make sure the drive address to be formatted is correct. This procedure will erase all information on the disk.

1. Power-off the computer.
2. Insert the **ThinkPad 755Ce hardware maintenance diskette** into diskette drive **A** and power-on the computer. (You can use this maintenance diskette for all ThinkPad models.)
3. Select **Format the hard disk** from the main menu.
4. Select the drive from the menu.
5. Follow the instructions on the screen.

PC Test Card LED

The green LED on the PC test card turns on when the PCMCIA test is running. If the LED does not turn on, check that the card is installed correctly by reseating the card. If it still does not turn on after it is reseated, try using another slot for the test. If the LED still does not turn on and the test fails, replace the FRU shown in the diagnostic error code.

Fn Key Combinations

The following table shows the **Fn** key and function key combinations and their corresponding functions.

The Fn key works independently from the operating system. The operating system obtains the status through the system management interface to control the system.

Fn +	Description
F1	Reserved
F2	Fuel-gauge display ON/OFF
F3	Standby mode invocation
F4	Suspend mode invocation
F5	Audio volume Down
F6	Audio volume UP
F7	LCD/CRT display switching
F8	Reserved
F9	Reserved
F10	Reserved
F11	Power management mode switching (Toggles High power, Intelligent, Economy)
F12	Hibernation invocation

How To Run the Keyboard Diagnostics

Do the following to run the keyboard test.

1. Go to the advanced diagnostic screen menu by pressing **Ctrl+A** in the Easy-Setup menu.
2. Go to the keyboard diagnostic test menu by pressing **Ctrl+K**.
3. Check that when each key is pressed, the key position on the keyboard layout on the screen changes to a black square.

Note: When a Fn key is pressed, a black square briefly appears.

Product Overview

The following table shows an overview of the system features.

Feature	Description
Processor	<ul style="list-style-type: none">• 755CE, 755CSE, 755CV<ul style="list-style-type: none">– Intel DX4 100/33 MHz• 755CX<ul style="list-style-type: none">– P54C-75 MHz w/ L2 cache
Bus Architecture	<ul style="list-style-type: none">• AT Bus• VESA Local Bus for video subsystem
Memory (Standard)	8MB (on the system board)
Memory (Option)	<ul style="list-style-type: none">• 2, 4, 8, 16MB, Basic IC DRAM card (max. 16 MB)• 4, 16MB, DIMM card (max. 32 MB)• DIMM card adapter
CMOS RAM	128 Bytes
VGA Video	<ul style="list-style-type: none">• 755CE, 755CV<ul style="list-style-type: none">– 10.4-inch, 65 536 colors, TFT color LCD• 755CSE<ul style="list-style-type: none">– 10.4-inch, 256 colors, STN color LCD• 755CX<ul style="list-style-type: none">– 10.4-inch, 65 536 colors, VGA TFT color LCD (640 by 480 resolution)– 10.4-inch, 65 536 colors, SVGA TFT color LCD (800 by 600 resolution)
Diskette Drive (Removable)	<ul style="list-style-type: none">• 0.720, 1.2, 1.44, 2.88MB (4-mode), 3.5-inch• 0.720, 1.44, (2-mode), 3.5-inch
Hard Disk Drive (Removable)	<ul style="list-style-type: none">• 340MB, 2.5-inch• 540MB, 2.5-inch• 810MB, 2.5-inch
DSP Card	<ul style="list-style-type: none">• Microphone jack• Headphone jack• Modem port

Feature	Description
IR	Two IR ports
PCMCIA	One Type-III or two Type-II

FRU Removals and Replacements

This section contains information about removals and replacements.

- An electrostatic discharge (ESD) strap must be used to establish personal grounding.
The system board is sensitive to, and can be damaged by, electrostatic discharge. Establish personal grounding by touching a ground point with one hand before touching these units.
- The arrows in the “Removals and Replacements” section show the direction of movement to remove a FRU, or to turn a screw to release the FRU. The arrows are marked in numeric order, in square callouts, to show the correct sequence of removal.
- When other FRUs must be removed before removing the failing FRU, they are listed at the top of the page.
- To replace a FRU, reverse the removal procedure and follow any notes that pertain to replacement. See “Locations” for internal cable connections and arrangement information.
- When replacing a FRU, use the correct screw size as shown in the procedures.

Safety Notice 8: Translation on page 13

Before removing any FRU, power-off the computer, unplug all power cords from electrical outlets, remove the battery pack, and then disconnect any interconnecting cables.

Safety Notice 3: Translation on page 9

The battery pack contains small amounts of nickel. Do not disassemble it, throw it into fire or water, or short-circuit it. Dispose of the battery pack as required by local ordinances or regulations.

Safety Notice 1: Translation on page 7

Before the computer is powered-on after FRU replacement, make sure all screws, springs, or other small parts, are in place and are not left loose inside the computer. Verify this by shaking the computer and listening for rattling sounds. Metallic parts or metal flakes can cause electrical short circuits.

1010 Rear Connector Door

Remove the center latch **1**; then remove the rear connector door by flexing it **2**.

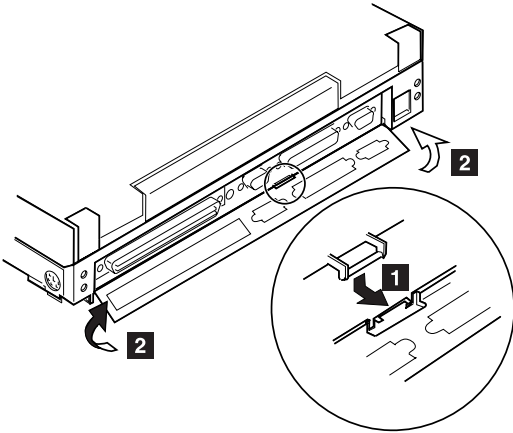

1015 Foot

To replace the foot:

- Align the foot in the open position with one pivot in its hinge in the base cover
- Press the other pivot point into position with your thumb or finger

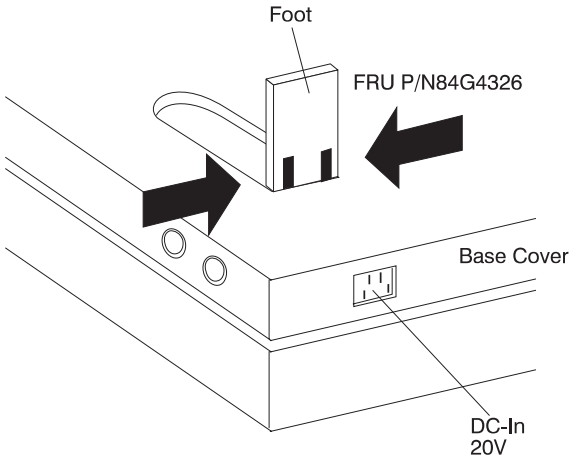

1020 Battery Pack

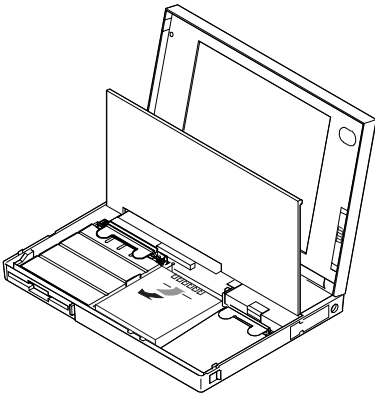

Notes:

1. Be careful that the computer does not fall backward when the battery pack is removed.
2. When replacing the battery pack, check that the storage switch of the new battery is set to the on (I) position. Do not operate the storage switch of a battery that has been used and is going to be re-used.
3. Check that the keyboard latch springs are in place.

1030 Diskette Drive

- Battery Pack (1020)

Note: Remove the diskette drive exactly as shown in the figure. Do not apply any extra force to the top surface of the diskette drive. Make sure the media is removed, or the media and the drive may be damaged.

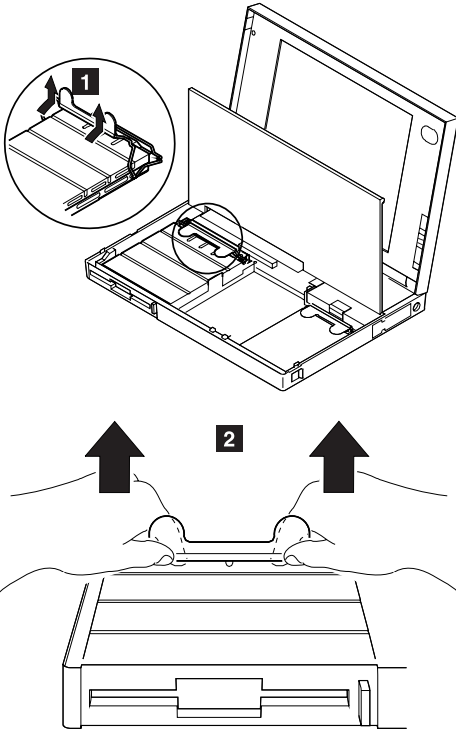

Warning: When replacing the diskette drive, check that the backup battery and standby battery are seated correctly to prevent damage to the diskette drive.

After replacing the diskette drive, latch the removal strap into the correct position.

1040 Hard Disk Drive

- Battery Pack (1020)

Notes:

1. **Do not drop or apply any shock to the hard disk drive.** The hard disk drive is sensitive to physical shock. Incorrect handling can cause damage it, and cause permanent loss of data on the hard disk. Before removing the hard disk drive, have the user make a backup copy of all the information on the hard disk. Never remove the hard disk drive while the system is operating or is in suspend mode.
2. Remove the hard disk drive exactly as shown in the figure. Do not apply any extra force to the hard disk drive when removing it.

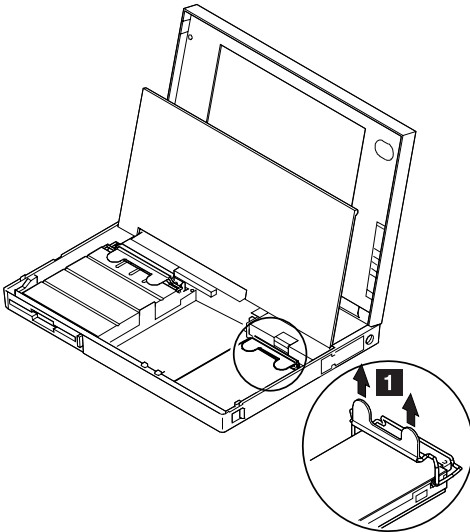

Note: After replacing the hard disk drive, latch the removal strap into the correct position.

1050 IC DRAM Card or DIMM Adapter

- Battery Pack (1020)
- Diskette Drive (1030)

Note: One of the following combinations occupies the slot depending on the configuration.

- IC DRAM card + IC DRAM card base
- DIMMs on DIMM adapter

If the IC DRAM Card is installed:

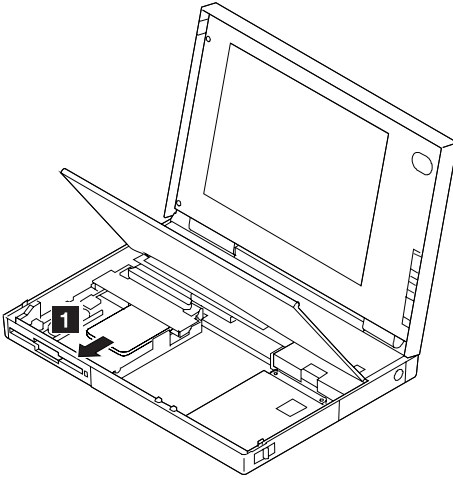

Warning: The IC DRAM card is sensitive to physical shock. Incorrect handling of the card can damage it. The eject tape (P/N 53G9318) must be used to remove the card.

If the DIMM Adapter is installed:

Press both locks at the same time and remove the DIMM.

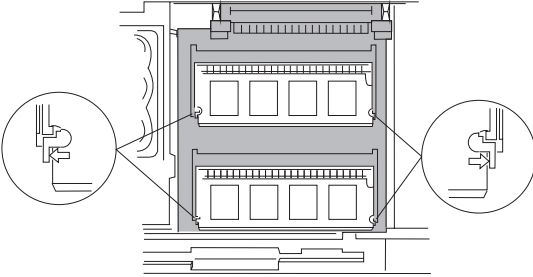

While holding the strap **A**, pull the DIMM adapter toward the front to remove it.

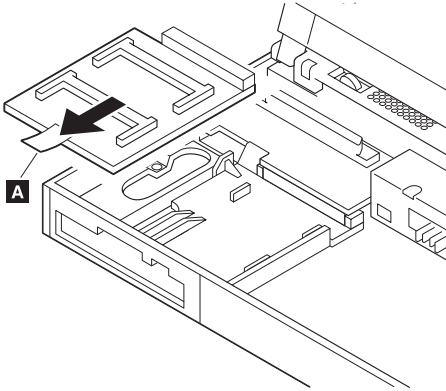

Notes:

1. If the IC DRAM cards or the DIMM are not installed and the base plate is installed instead of these cards, remove the plate as follows:
 - a. Pinch the projection **A** on the left side of the plate; then pull the plate slightly toward the front.
 - b. Raise the rear portion of the plate and remove it.

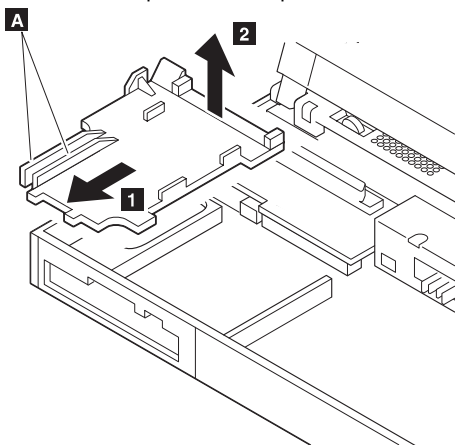

2. When inserting the DIMM into either connector on the DIMM adapter:
 - a. Locate the triangle **A** on the right side of the socket.
 - b. With the notched end of the DIMM **B** toward the triangle, insert the DIMM into the socket.
 - c. Pivot the DIMM until it snaps into place.

If you have another DIMM to install, insert it in the other socket the same way.

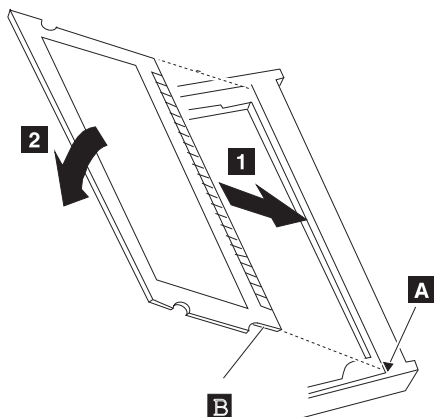

1070 Diskette Drive Bezel

- Battery Pack (1020)
- Diskette Drive (1030)

Insert a coin between the diskette drive bezel and the computer as shown **1** and push the bezel from the bottom of the computer **2** to remove it.

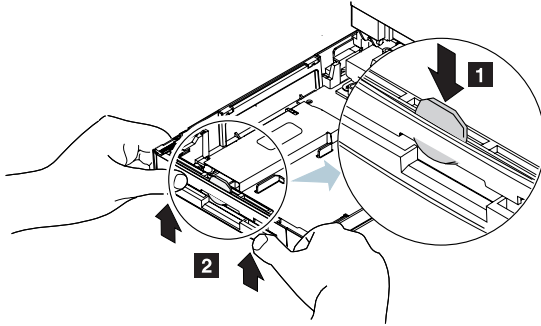

1080 Keyboard Unit

- Battery Pack (1020)

Loosen the three screws **2**, and push **3** to release the four top cover latches at the rear side of the system unit.

When removing the screw covers **1**, use a small screwdriver.

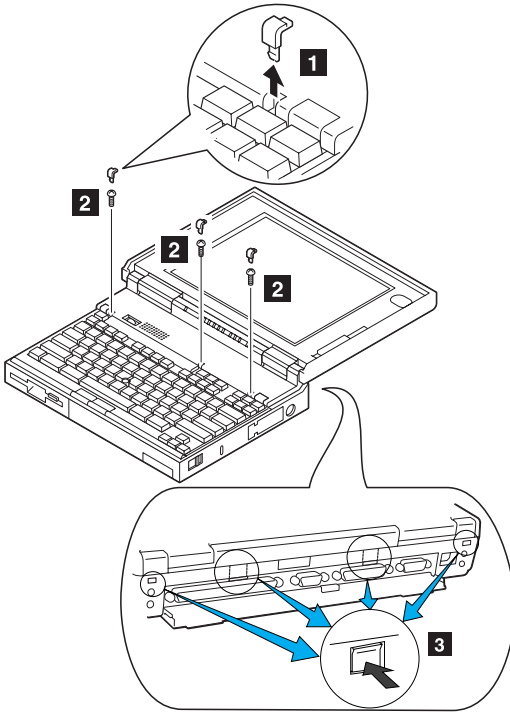

The keyboard unit is connected to the system board with flexible cables.

Warning: Do not pull the keyboard cables. The keyboard cables can be damaged if the keyboard is disconnected without releasing the three latches **5**.

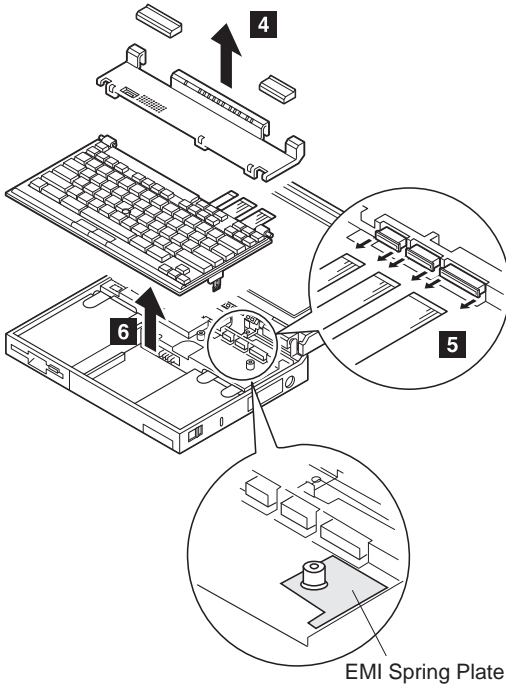

Notes:

1. When replacing the keyboard, check that the three cables are clean, and inserted straight and fully into the connectors. Slide both ends of each latch at the same time to make sure that each cable is correctly inserted. Go to “Keyboard/Auxiliary Input Device Checkout” on page 396 and test all keys before returning the computer to the customer.
2. When replacing the top cover, insert the four latches at the rear side of the cover into the foot guide of the LCD; push the right, left, and front sides to snap it into place.

Use the following table for reference when replacing parts.

Step	Location (Quantity)	Length
2	Top cover (3)	4 mm
Note: Make sure you use the correct screw.		

1090 Status Indicator

- Battery Pack (1020)
- Keyboard Unit (1080)

Warning: Do not pull the status indicator cable. The cable can be damaged if the status indicator is disconnected without releasing the latch in step 2.

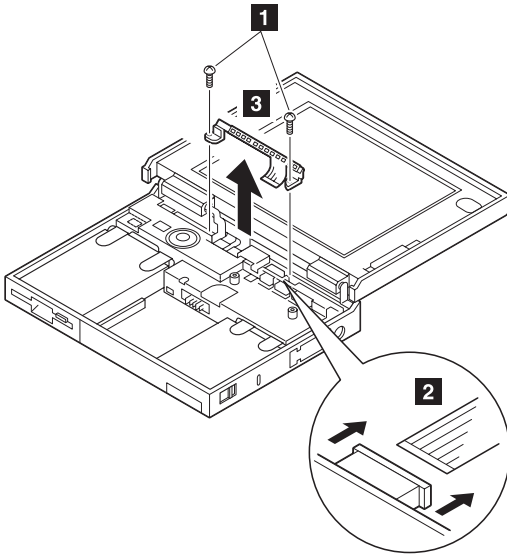

Note: When replacing the indicator, insert the flexible cable straight into the connector until the head of the cable stops. Slide both ends of the latches at the same time to make sure that the cable is correctly inserted.

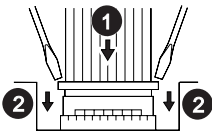

Use the following table for reference when replacing parts.

Step	Location (Quantity)	Length
1	LED Stand off (2)	6 mm
Note: Make sure you use the correct screw.		

1100 Standby Battery and Front IR

- Battery Pack (1020)
- Diskette Drive (1030)

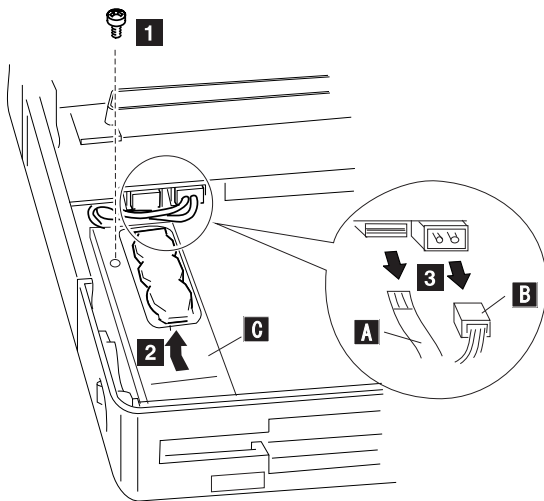

Where:

- A** is the IR Cable.
- B** is the Standby Battery Cable.
- C** is the IR Lens.

Note: When replacing the battery, make sure the battery is seated correctly. Make sure the IR Lens **2** is in the correct position by sliding it end to end.

Step	Location (Quantity)	Length
1	cover (1)	4 mm

Note: Make sure you use the correct screw.

Safety Notice 2: Translation on page 8

The standby battery contains a small amount of nickel and cadmium. Do not disassemble it, recharge it, throw it into fire or water, or short-circuit it. Dispose of the battery as required by local ordinances or regulations.

1110 Backup Battery

- Battery Pack (1020)

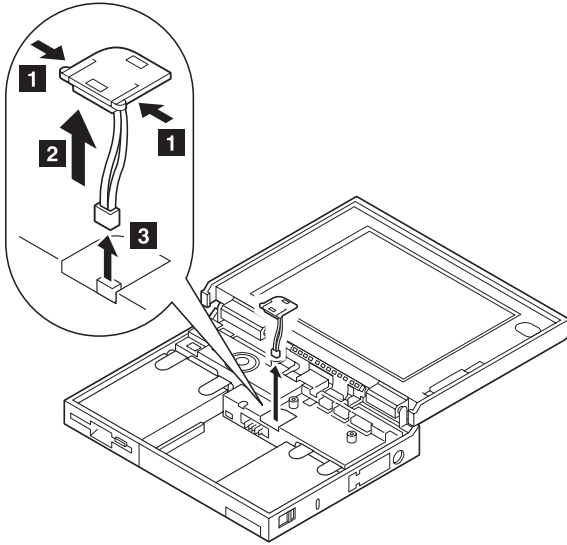

Safety Notice 4: Translation on page 10

The backup battery is a lithium battery and can cause a fire, explosion, or severe burn. Do not recharge it, remove its polarized connector, disassemble it, heat it above 100°C (212°F), incinerate it, or expose its cell contents to water. Dispose of the battery as required by local ordinances or regulations. Use of an incorrect battery can result in ignition or explosion of the battery. Replacement batteries can be ordered from IBM or IBM Authorized Dealers.

1115 Logic Assembly

- Battery Pack (1020)
- Diskette Drive (1030)
- Hard Disk Drive (1040)
- Keyboard Unit (1080)
- Status Indicator (1090)
- Standby Battery and Front IR (1100)

The screw **1** is located at the rear bottom side.

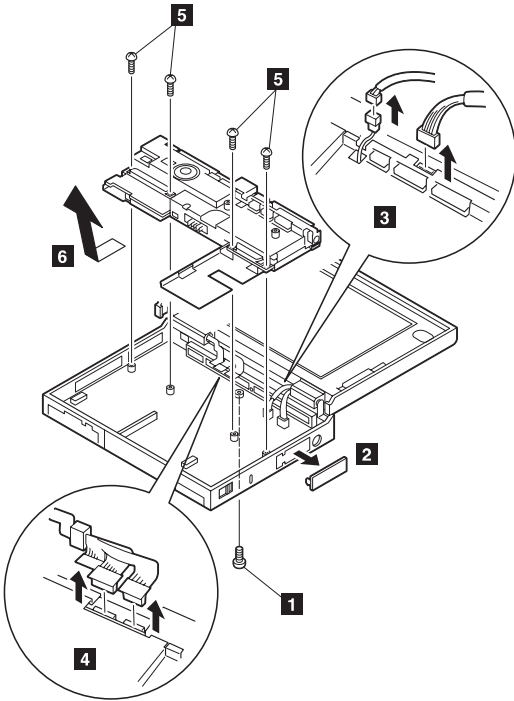

See next page.

When Replacing Logic Assembly

When replacing the logic assembly, align the power-key slide hub with the power-switch actuator by moving the power-key in the direction of the arrow

1. See the large circle in the figure. Before tightening any screws, check that the power-switch operates correctly.

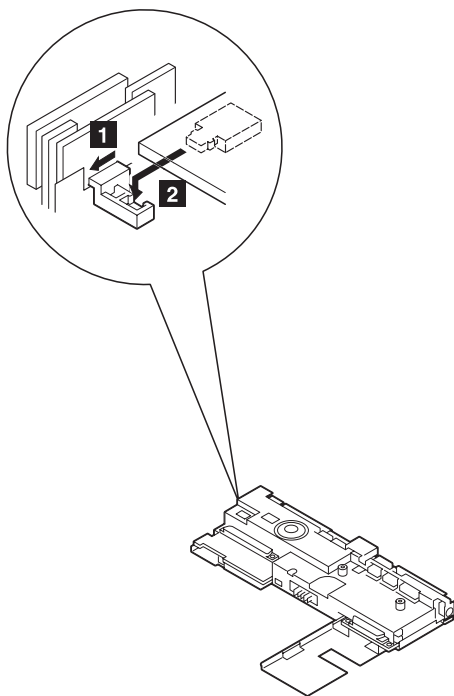

Step	Location (Quantity)	Length
1	Bottom cover (1)	4 mm
5	Logic assembly (4)	8 mm

Note: Make sure you use the correct screw.

1120 Shield Assembly

- Battery Pack (1020)
- Diskette Drive (1030)
- Hard Disk Drive (1040)
- Keyboard Unit (1080)
- Status Indicator (1090)
- Standby Battery and Front IR (1100)
- Backup Battery (1110)
- Logic Assembly (1115)

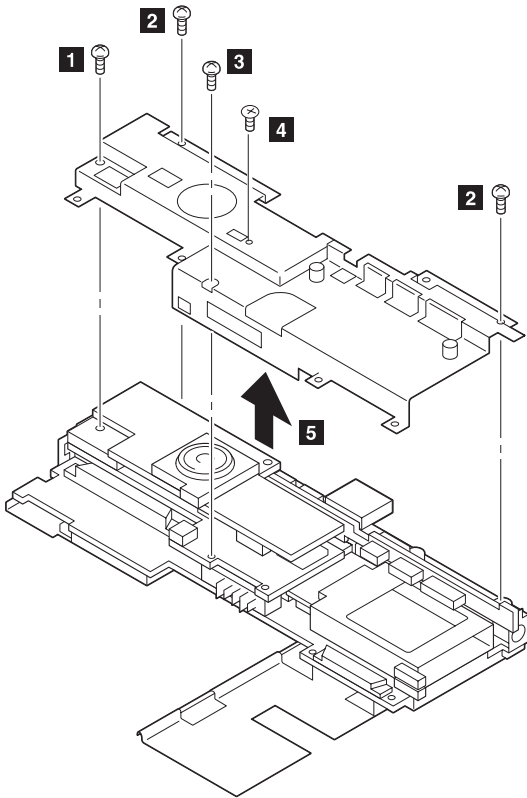

See the next page when you replace the parts.

The microphone cable can pick up electrical noise if the cable path is incorrect.

Do the following to place the cable in its correct position.

1. Position the cable as shown.

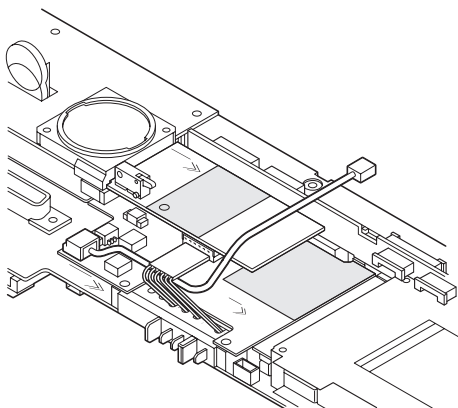

2. Install the shield assembly.
3. Move the end of cable to the right.

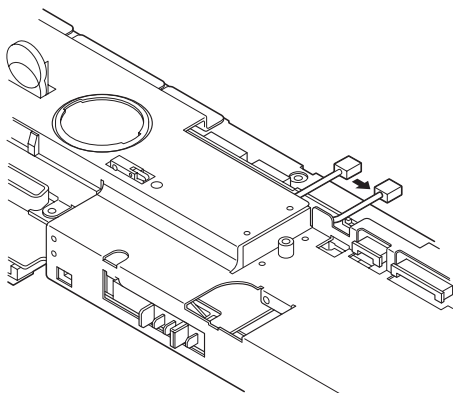

The following figure shows the final path of the cable. Make sure the cable is not positioned in any shaded area.

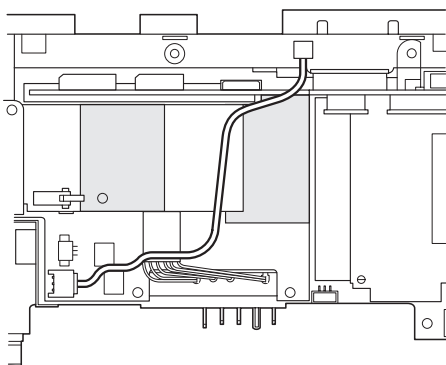

Use the following table for reference when replacing parts.

Step	Location (Quantity)	Length
1	Shield cover (1)	4 mm
2	Shield cover (2)	6 mm
3	Shield cover (1)	14 mm
4	Shield cover (1)	Flat head
Note: Make sure you use the correct screw.		

1130 DC/DC Card

- Battery Pack (1020)
- Diskette Drive (1030)
- Hard Disk Drive (1040)
- Keyboard Unit (1080)
- Status Indicator (1090)
- Standby Battery and Front IR (1100)
- Backup Battery (1110)
- Logic Assembly (1115)
- Shield Assembly (1120)

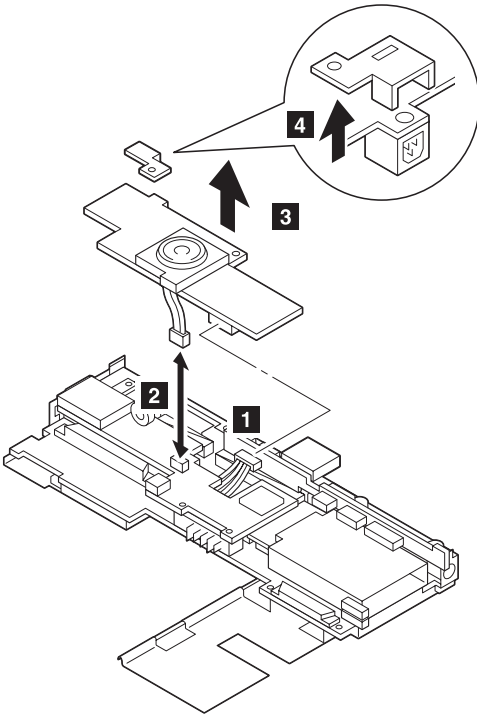

1140 DSP Card

- Battery Pack (1020)
- Diskette Drive (1030)
- Hard Disk Drive (1040)
- Keyboard Unit (1080)
- Status Indicator (1090)
- Standby Battery and Front IR (1100)
- Backup Battery (1110)
- Logic Assembly (1115)
- Shield Assembly (1120)
- DC-DC Card (1130)

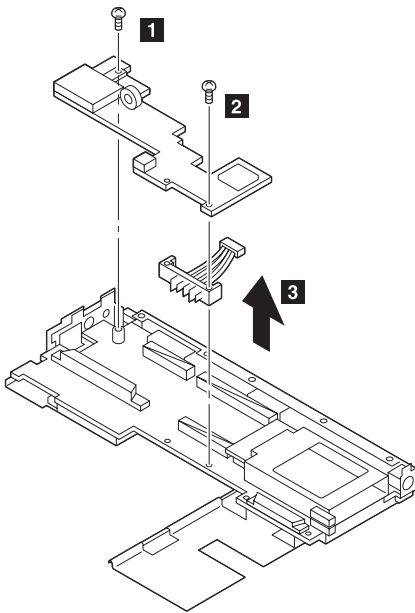

Remove the following:

- Mini-Jack Holder
- Modem Guide
- Modem Lever
- Microphone Cable

Use the following table for reference when replacing parts.

Step	Location (Quantity)	Length
1	DSP card (1)	6 mm
2	DSP card (1)	14 mm

Note: Make sure you use the correct screw.

1150 Interposer Card and Rear IR

- Battery Pack (1020)
- Diskette Drive (1030)
- Hard Disk Drive (1040)
- Keyboard Unit (1080)
- Status Indicator (1090)
- Standby Battery and Front IR (1100)
- Backup Battery (1110)
- Logic Assembly (1115)
- Shield Assembly (1120)
- DC-DC Card (1130)
- DSP Card (1140)

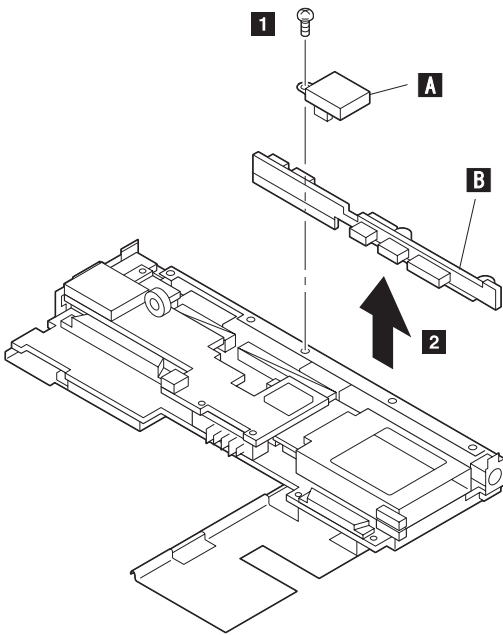

Where:

A is the Rear IR.

B is the Interposer Card.

Use the following table for reference when replacing parts.

Step	Location (Quantity)	Length
1	Interposer card (1)	4 mm
Note: Make sure you use the correct screw.		

1160 System Board Assembly

- Battery Pack (1020)
- Diskette Drive (1030)
- Hard Disk Drive (1040)
- Keyboard Unit (1080)
- Status Indicator (1090)
- Standby Battery and Front IR (1100)
- Backup Battery (1110)
- Logic Assembly (1115)
- Shield Assembly (1120)
- DC/DC Card (1130)
- DSP Card (1140)
- Interposer Card and Rear IR (1150)
- Processor Card (1180)
- PCMCIA Slot Assembly (1170)

Notice

The EEPROM on the system board contains the vital product data (VPD), that is, system unit serial number, system board serial number, and other computer unique data. When the system board is replaced, the system unit serial number must also be restored. Use the **Set system identification** utility on the maintenance diskette to restore the number.

Do not power-off the computer when restoring the VPD.

The serial number label is attached to the bottom cover.

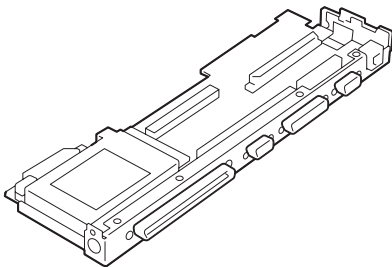

Notes:

1. Before removing and replacing the system board, make sure that the PCMCIA cards are removed and the eject levers are not sticking out.
2. Do not pull the PCMCIA slot assembly while removing the system board.

1170 PCMCIA Slot Assembly

- Battery Pack (1020)
- Diskette Drive (1030)
- Hard Disk Drive (1040)
- Keyboard Unit (1080)
- Status Indicator (1090)
- Standby Battery and Front IR (1100)
- Backup Battery (1110)
- Logic Assembly (1115)
- Shield Assembly (1120)
- DC/DC Card (1130)
- DSP Card (1140)
- Interposer Card and Rear IR (1150)
- Processor Card (1180)
- System Board Assembly (1160)

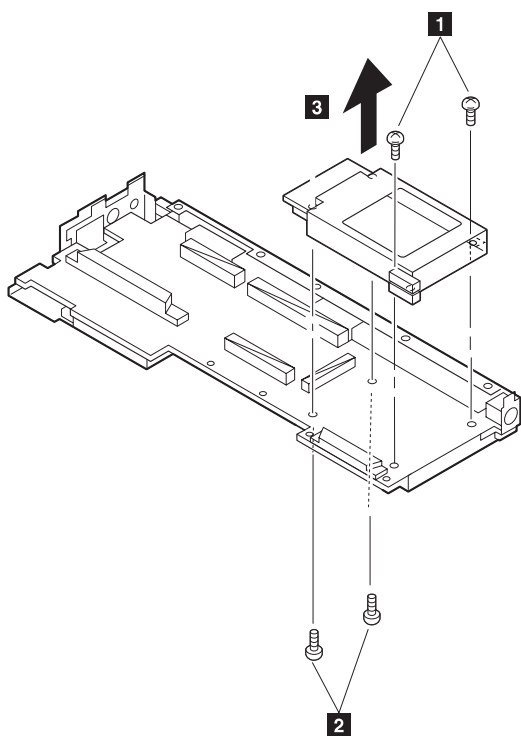

Notes:

1. When handling the PCMCIA slot assembly, be careful not to disassemble any part of it. The slot assembly is not solidly fixed when it is removed from the system board or the FRU.
In step **3**, gently pull up the bottom of the center area of the connector board edge with your fingers.
2. The screw stand at each corner of the PCMCIA slot is

easy to remove. Make sure that the screw stand is correctly positioned when the slot is replaced. Do not replace the slot without the screw stand.

Use the following table for reference when replacing parts.

Step	Location (Quantity)	Length
1	PCMCIA slot, upper (2)	4 mm
2	PCMCIA slot, lower (2)	14 mm
Note: Make sure you use the correct screw.		

1180 Processor Card

- Battery Pack (1020)
- Diskette Drive (1030)
- Hard Disk Drive (1040)
- Keyboard Unit (1080)
- Status Indicator (1090)
- Standby Battery and Front IR (1100)
- Backup Battery (1110)
- Logic Assembly (1115)

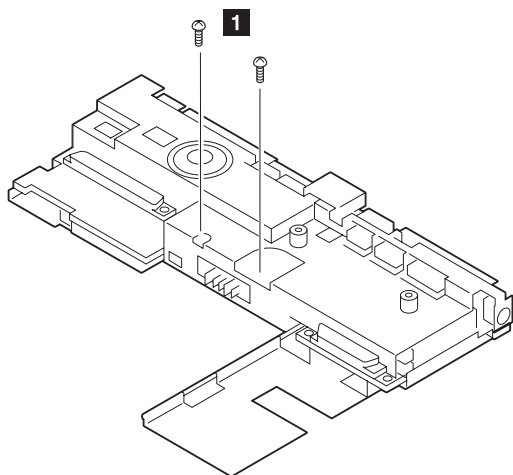

Turn the system board upside down. Then remove any metal tape holding the card.

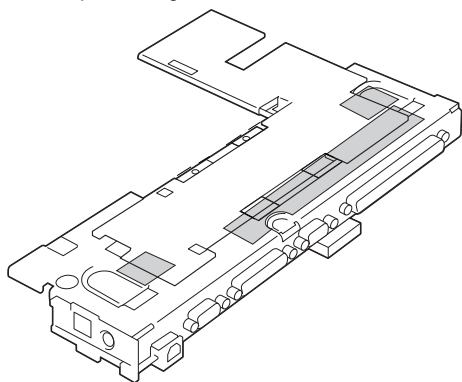

To remove the processor card, gently lift the area shown by **A** straight up. Do not pull the other areas.

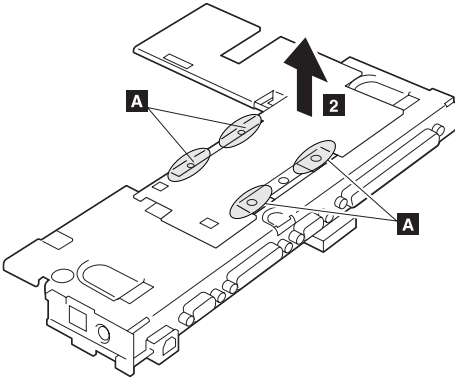

Note: If the processor card is not installed correctly, the computer may not turn on. Reinstall the card in this case.

Use the following table for reference when replacing parts.

Step	Location (Quantity)	Length
1	Processor card assembly	14 mm
Note: Make sure you use the correct screw.		

1190 LCD Assembly

- Battery Pack (1020)
- Keyboard Unit (1080)
- Status Indicator (1090)

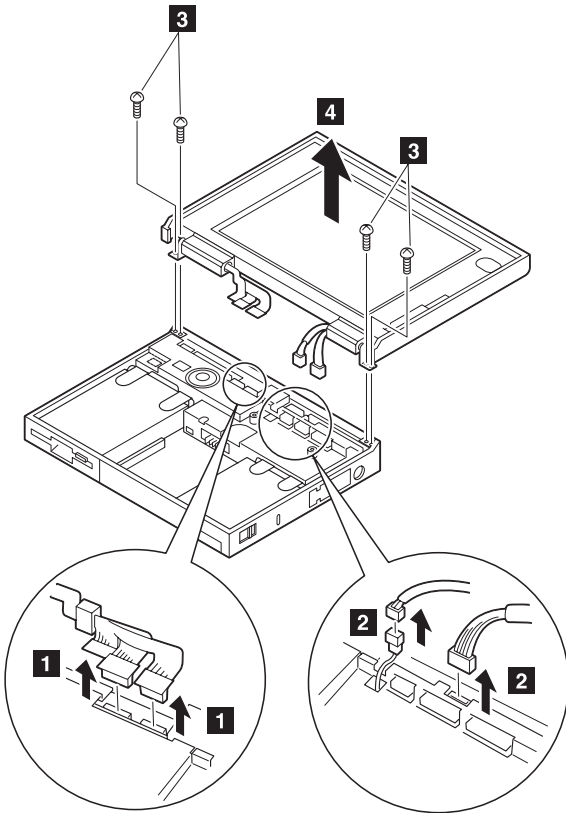

Note: When removing the LCD cables **1**, pull the connector straight up. Incorrect handling can damage the connector.

Use the following table for reference when replacing parts.

Step	Location (Quantity)	Length
3	LCD hinge (4)	4 mm
Note: Make sure you use the correct screw.		

Safety Notice 5: Translation on page 11

If the LCD breaks and the fluid from inside the LCD gets into your eyes or on your hands, immediately wash the affected areas with water for at least 15 minutes. Seek medical care if any symptoms from the fluid are present after washing.

Note: To clean the LCD, gently wipe the LCD with a dry, soft cloth. Do not use alcohol or detergent to clean the LCD.

To avoid damaging the LCD, do not scratch or apply any force to its surface.

1195 LCD Rear Cover (755CV only)

Slightly push out and release the latches **1**.

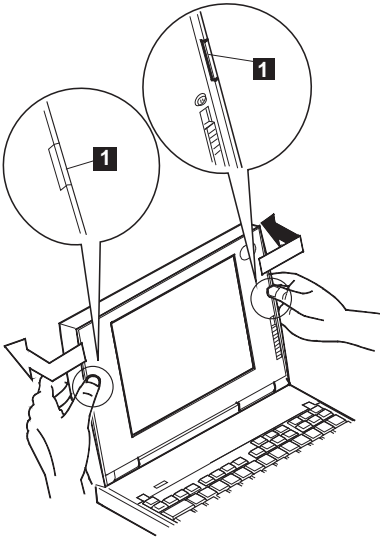

Note: While the cover is removed from the LCD, do not touch the film (**2**) on the rear cover.

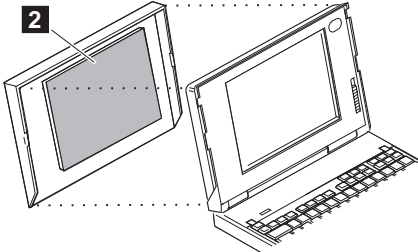

1200 Lower Shield Assembly

- Battery Pack (1020)
- Diskette Drive (1030)
- Hard Disk Drive (1040)
- Keyboard Unit (1080)
- Status Indicator (1090)
- Standby Battery and Front IR (1100)
- Backup Battery (1110)
- Logic Assembly (1115)
- Shield Assembly (1120)
- DC/DC Card (1130)
- DSP Card (1140)
- Interposer Card and Rear IR (1150)
- Processor Card (1180)
- PCMCIA Slot Assembly (1170)
- System Board Assembly (1160)

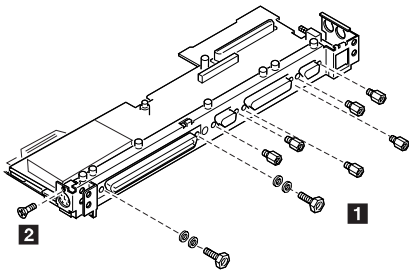

1210 Memory Card

- Battery Pack (1020)
- Diskette Drive (1030)
- Hard Disk Drive (1040)
- Keyboard Unit (1080)
- Status Indicator (1090)
- Standby Battery and Front IR (1100)
- Backup Battery (1110)
- Logic Assembly (1115)
- Shield Assembly (1120)
- DC/DC Card (1130)
- DSP Card (1140)
- Interposer Card and Rear IR (1150)
- Processor Card (1180)
- PCMCIA Slot Assembly (1170)
- System Board Assembly (1160)
- Lower Shield Assembly (1200)

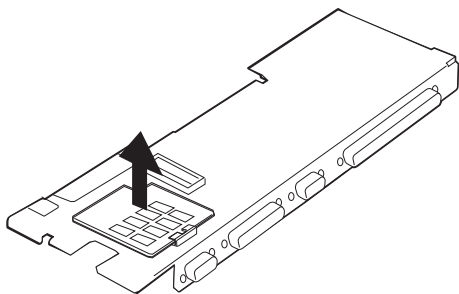

Note: If the computer does not complete POST after changing the memory card, reseal the card and try again.

Locations

Front View

- 1** LCD
- 2** Built-in Microphone
- 3** Brightness Control
- 4** Status Indicator
 - See "Status Indicators" on page 420.
- 5** External Input Device Connector
- 6** PCMCIA Slot
- 7** PCMCIA Release Lever
- 8** Keyboard
- 9** LCD and Keyboard Latch
- 10** Click Button
- 11** Diskette-Eject Button
- 12** Diskette Drive
- 13** Front Infrared Port
- 14** Fn Key
- 15** TrackPoint III
- 16** Volume Knob
- 17** Built-in Speaker

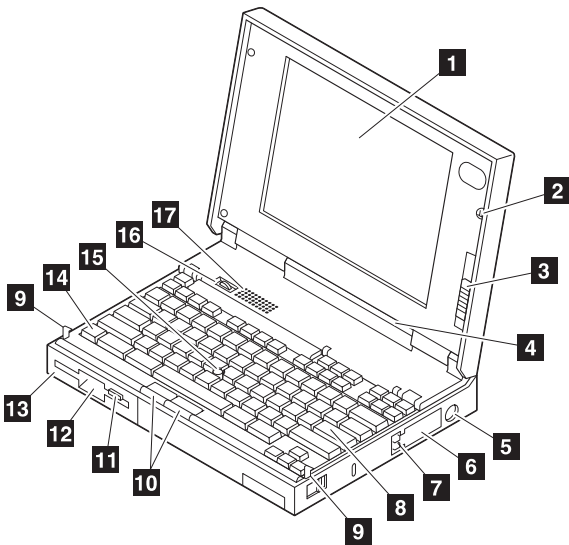

Rear View

- 1** Telephony Jack
- 2** Microphone/Line-In Jack
- 3** Headphone Jack
- 4** Power Switch
- 5** Power Jack
- 6** Serial Connector
- 7** Parallel Connector
- 8** External-Display Connector
- 9** Reset Switch
- 10** Rear Infrared Port
- 11** System Expansion Connector

A multimedia portable expansion unit, port replicator, or port replicator with PCMCIA can be connected to this interface to support the following features.

- 16-bit AT-bus interface
- Serial port
- Parallel port
- Keyboard and mouse
- HDD connection
- LED control signals
- Visual signals
- Audio signals
- FDD signals
- PCMCIA signals
- Power controls
- Power line

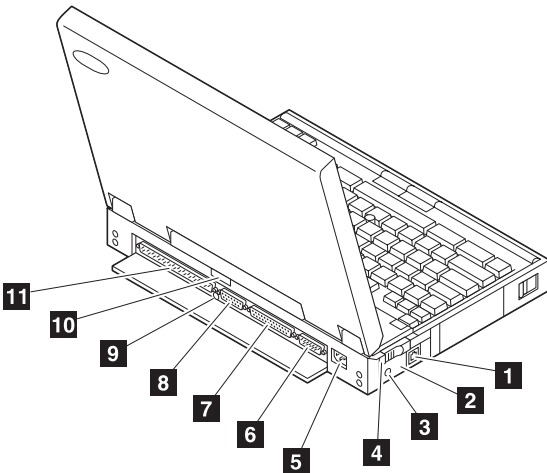

Parts Listing

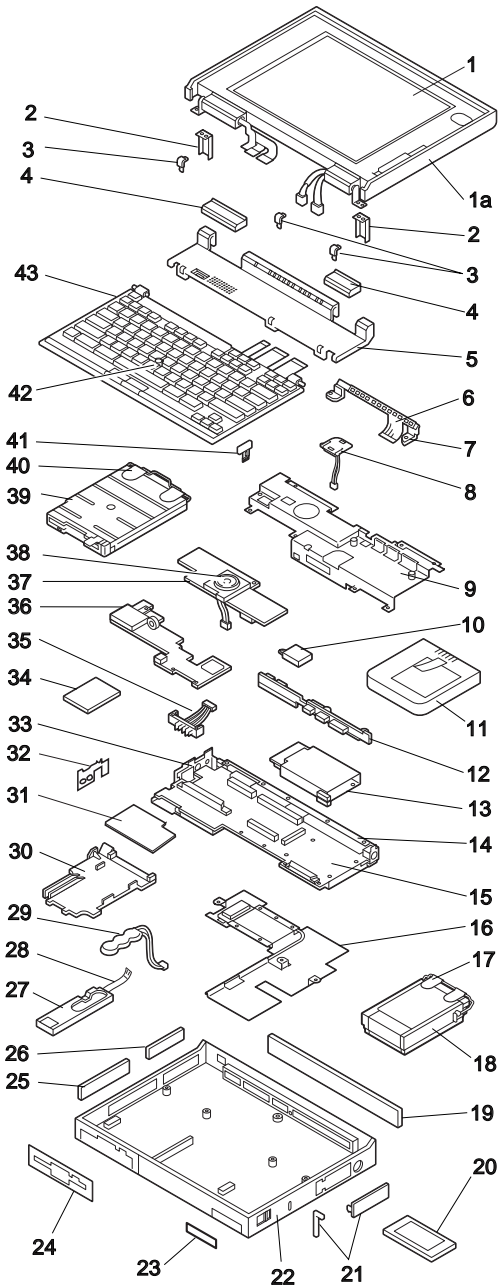

System Unit (755CE/755CSE/755CV/755CX)

Index Component

1	LCD Assembly (755CE)	85G1489
	LCD Assembly (755CSE)	85G1490
	LCD Assembly, (755CX TFT-VGA)	85G1489
	LCD Assembly, (755CX TFT-SVGA)	85G8546
	LCD Assembly, Front (755CV)	85G1633
1a	LCD Assembly, Rear cover (755CV)	85G1630
2	Hinge Bracket, Right, Left	85G1507
3	Screw Rubber Lid	85G1509
4	Hinge, Lid, Right/Left	84G6555
5	Top Cover (755CE)	85G1491
	Top Cover (755CSE)	85G1492
	Top Cover (755CV)	85G7472
	Top Cover (755CX)	85G8547
6	LED Assembly	84G6547
7	Stand-off, LED	84G6554
8	Backup Battery	85G1501
9	Shield Case, Upper	85G1496
10	IR Assembly, rear	85G1563
10	IR Lens, rear	84G6550
11	Battery Pack (Ni-MH)	85G1510
	Battery Pack (Li-ion) (for 755CX, option for 755CV)	85G8554
12	Interposer Card	85G1503
13	PCMCIA Slot Assembly	85G1062
14	Lower Shield	85G1497
15	System Board (755CE, 755CSE, 755CV)	85G1141
	System Board (755CX)	85G8548
16	Processor Card (25/75 MHz)	85G1494
	Processor Card (33/100 MHz)	85G1495
	Processor Card (755CX)	85G8550
17	HDD Removal Strap	66G5122
18	340MB Hard Disk Drive	66G5068
	540MB Hard Disk Drive	84G4319
	810MB Hard Disk Drive	85G0961
19	Rear Connector Cover	66G5050
20	PCMCIA Device (See options)	
21	PCMCIA Cover (Includes bezels and security plate)	85G1511
22	Base Cover Assembly (755CE) For Japan	85G1486 85G1488
	Base Cover Assembly (755CSE)	85G1026
	Base Cover Assembly (755CV) For Japan	85G1105 85G1106
	Base Cover Assembly (755CX) For Japan	85G8545 85G8570
23	Name Label	66G9228
24	Bezel, Diskette Drive	85G1036
	Bezel, Blank	85G1891
25	Cover, Option Bay	85G1037
26	AV Door	84G6551
27	IR Lens, Front	84G6548
28	IR Assembly, Front	84G6549
29	Standby Battery	85G1039
30	Base Plate	84G6563
31	Memory Card (755CE, 755CSE, 755CV)	84G6561
	Memory Card (755CX)	85G8565
32	AV Panel	84G6552
33	Power Switch Button	84G6553
34	IC DRAM Card (See options)	

Index Component

35	Battery Terminal (755CE, 755CSE)	84G6556
	Battery Terminal (755CV, 755CX)	85G8568
36	DSP Card Assembly	85G1140
37	DC/DC Card (755CE, 755CSE)	85G1500
	DC/DC Card (755CV, 755CX)	85G8551
38	Speaker	84G6557
39	Diskette Drive (4-mode)	66G5060
	Diskette Drive (3-mode)	84G2269
40	Diskette Drive Removal Strap	66G5123
41	Keyboard Security Plate	85G1508
42	TrackPoint III Cap	84G6536
43	Keyboard Assembly (See Keyboards)	
	Connection Cable, Microphone	84G6559
	Modem Connector Assembly, U.S.	85G1504
	Modem Connector Assembly, EMEA.	85G1505
	Modem Connector Assembly, blank.	84G6564
	Wall Plug, Modem	85G2367
	PCMCIA Cartridge	84G1303
	PCMCIA RF Cartridge	84G1304
	Head Phone	85G1529
	Interface Cable, System - Keyboard	84G2531
	Interface Cable, Keyboard - Keypad	84G2532
	Cable, Mini-DIN to Mini-DIN	84G6474
	AC Adapter (35W, 3-pin)	85G4952
	For Japan (2-pin)	85G6669
	DC Plug (4 pin, 2-pin)	85G6664
	EMI Spring Plate	85G1066
	Foot (right, left)	84G4326
	Extension DC Cable (755CV)	84G7466
	DC Adapter Cable (755CV)	85G7466
	Strap (755CV)	85G1104
	Computer Stand (755CV)	85G1635
	Remote Control (755CV)	

Notes: The warranty for this component is provided by an outside company. See the warranty sheet supplied with this component. Call MindPath Technologies Inc.
12700 Park Central Drive Suite 1707
Dallas, Texas 75251
Tel. (214) 233-9296, 9308 (FAX)

Keyboard

Arabic	84G6508
Belgian	84G6506
Canadian French	84G6514
Danish	84G6505
Dutch	84G6503
French	84G6499
German (Black)	84G6497
Greek	84G6512
Hebrew	84G6509
Italian	84G6501
Japanese	84G6515
Latin American	84G6513
Norwegian	84G6507
Portuguese	84G6510
Spanish	84G6504
Swedish	84G6502
Swiss/French	84G6500
Swiss/German	84G6498
Turkish	84G6511
U.K. English	84G6496
U.S. English	84G6495

Common/Option Parts List

Miscellaneous Parts

Miscellaneous Parts Kit (Includes Modem guide; modem lever; DC-IN holder; memory spacer; mini-jack holder; back-up battery holder; suspend-switch holder)	84G6558
Screw Kit (Includes 20-2.5 x 6 mm; 10-2.5 x 4 mm; 10-2.5 x 8 mm; 10-2.5 nut mm; 10-hex stud bus; 10-washer bus; 10-2.5 x 8 mm (flat head); 10-2.5 x 5 (deform screw); 10-spring lock washer; 10-hex stud d sub; 10-2.5 x 14; 10-heatsink nut)	84G6560
IC DRAM CARD Eject Tape	53G9318

DAA Assembly

Austria	59G1041
Australia	59G1040
Belgium	43G3414
Denmark	59G1042
Finland	59G1043
France	4525652
Germany	59G1056
Korea	66X2096
Malaysia	59G1066
Netherlands	43G3409
Norway	59G1044
New Zealand	43G3411
PRC/Hong Kong	54F0693
Singapore	66X2096
Sweden	54F0717
Switzerland	59G1057
Taiwan	59G1067
Thailand	59G1065
U.K.	59G1045

PSTN Cable

Austria	58G4386
Australia	58G4343
Belgium	58G4346
Denmark	58G4333
Finland	58G4334
France	58G4335
Germany	58G4347
W/W	43G3398
Netherlands	58G4340
Norway	58G4334
New Zealand/PRC/Hongkong	58G4332
Sweden	58G4336
Switzerland	58G4348
U.K.	58G4345

Options

Notes:

1. When you replace the AC Adapter or the Quick Charger with a new one, use the one for the country you are in even if the system is from different country.
2. The warranty for the system unit does not apply to all options.

AC Adapter (40W)	49G2196
For Japan	49G2197
AC Adapter (100 - 125 V ac, 40W)	84G4320
(This adapter is for U.S. only.)	
Audio Cable	66G5180
Car-Battery Adapter	49G1148
Small Car Battery Adapter	84G4359
Diskette Drive Attachment Unit	66G5069
IC DRAM CARD 2MB	07G1414
IC DRAM CARD 4MB	07G1415
IC DRAM CARD 8MB	07G1416
IC DRAM CARD 16MB	66G0094
Microphone	66G7871
Travel Quick Charger (3-pin)	85G1530
Quick Charger Cable	85G1531
DIMM 4MB	84G4323
DIMM 8MB	84G6545
DIMM 16MB	84G4324
DIMM Adapter Card	84G4322
Headset	85G1429

Numeric Keypad

Belgian	95F5741
Canadian French	95F5466
Danish	95F5467
Dutch	95F5467
French	95F6313
German	95F6314
Greek	95F5467
Hebrew	95F5741
Icelandic	95F5467
Italian	95F6316
Japanese	79F6401
Norwegian	95F5467
Spanish	95F6315
Swedish/Finnish	95F5468
Swiss/French	95F5711
Swiss/German	95F5715
Turkish	95F5467
U.K. English	95F5741
U.S. English	95F5741

Black Keypad

French	84G6286
German	84G6280
Italian	84G6292
Swedish	84G6304
U.K. English	84G6298
Norway	84G6310
U.S. English	84G2530

Black Keyboard

French	84G6285
German	84G6279
Italian	84G6291
Swedish	84G6303
U.K. English	84G6297
Norway	84G6309
U.S. English	84G2529

Accessories (Models 755x)

Keyboard/Mouse Cable	54G0444
----------------------	---------

Tools

Tri-Connector Wrap Plug	72X8546
PC Test Card	35G4703
Audio Wrap Cable	66G5180
Screwdriver Kit	95F3598
ThinkPad 750Ce	82G3891
Hardware Maintenance Diskette (This diskette is common to all ThinkPad models.)	

Power Cords

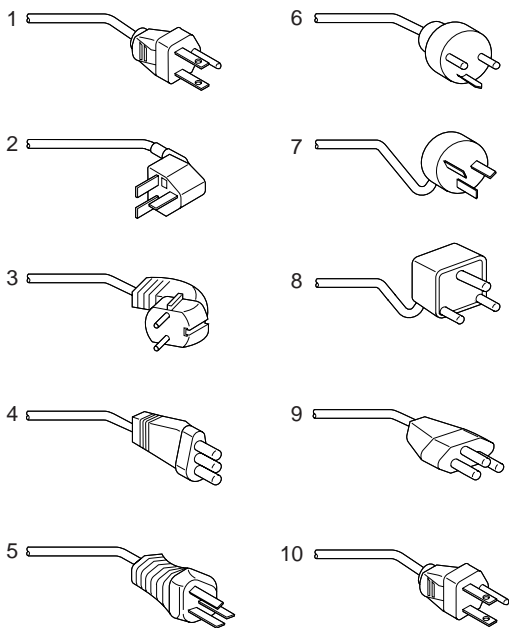

Warning: Use the power cord certified for your country.

	Country	30/40W	35W
1	Colombia, U.S., Venezuela Japan, 2-pin Japan, 3-pin	13F9959 6454377 65F0031	25H2207 85G6665
2	Hong Kong, Singapore, U.K.	14F0033	25H2215
3	France, Germany, Spain	13F9979	25H2209
4	Italy	14F0069	25H2223
5	Australia, New Zealand	13F9940	25H2205
6	Denmark	13F9997	25H2211
7	Israel	14F0087	25H2225
8	Bangladesh, Pakistan, Sri Lanka, South Africa	14F0015	25H2213
9	Switzerland	14F0051	25H2221
10	Thailand	1838574	25H2219

Note: The 30/40W cord is 6 feet long; the 35W cord is 6 inches.

Common Devices Checkout

External Diskette Drive Test	470
External Display Self-Test	470
External Keyboard/Auxiliary Input Device Checkout	471
Fax/Modem Checkout	472
Printer Checkout	474
Port Replicator Checkout	475
TrackPoint II Checkout	476
TV Tuner	477
Identifying Names and Functions	477
Using the Front Panel	478
Troubleshooting	481

External Diskette Drive Test

Use the following procedure to isolate the diskette problem to a controller, drive or diskette. A scratch, write-enabled 2HD diskette is required.

1. Select the icon **FDD** on the **TEST MENU**. By doing this, the controller test and the drive read/write test run. If the controller test detects an error, FRU code 10 appears. In this case, replace the system board.
2. If the controller test run without errors, follow the instructions on the screen and insert a scratch diskette.
3. If the drive test detects an error, FRU code 50 appears. If the diskette media are known to be good, replace the drive or the drive cable.

External Display Self-Test

If the display problem occurs only when using an external display, use the following instructions to correct the problem.

Note: Before you replace a display, check the following list to see if it is connected correctly.

- 8506 and 8508 displays must be connected to an Image Adapter/A or an Image-I Adapter/A.
- 63XX and 85XX systems support either 63XX or 85XX displays.
- 85XX systems with an XGA-2 adapter support 95XX displays.
- 95XX systems support either 63XX, 85XX, or 95XX displays.
- ThinkPad models support either 85XX or 95XX displays.

If the screen is rolling, replace the display assembly. If that does not correct the problem, replace FRUs in the following order until the problem goes away:

1. Video card
2. Display adapter (any type)
3. System board
4. Bus adapter (if used)

If the screen is not rolling, run the display self-test as follows:

1. Power-off the computer and display.
2. Disconnect the display signal cable.
3. Power-on the display.
4. Set the contrast to its maximum position.
5. Set the brightness control to the center detent position.

Check for the following conditions:

- You should be able to vary the screen intensity by adjusting the contrast and brightness controls.
- The screen should be white or light gray, with a black margin (test margin) on the screen.

Note: The location of the test margin varies with the type of display. The test margin might be on the top, bottom, or one or both sides.

If you do not see a test margin on the screen, replace the display. If there is a test margin on the screen, replace the system board.

Note: On ThinkPad Models 700, 700C, 720C, 720C, do the following:

1. Video card
2. System board

External Keyboard/Auxiliary Input Device Checkout

The following auxiliary input devices may be available for IBM ThinkPad models.

- Numeric keypad
- Mouse (PS/2 compatible)
- External keyboard (with Keyboard/Miniature Mouse cable)
- If you suspect a problem with any of the auxiliary input devices (listed above), replace the device. If the problem is not corrected, replace the following FRUs one at a time to correct the problem.
 - Keyboard control card
 - System board
- If the computer receives an incorrect keyboard response, remove other external devices, check the keyboard connections, and recheck the keyboard responses. If the problem remains, replace the following FRUs one at a time to correct the problem.
 - Keyboard
 - Keyboard control card
 - System board
- If a 00030100 error message appears, power-off the computer and the external devices. Then power-on the computer before you power-on the external devices.

Fax/Modem Checkout

001

- Power-off the computer.
- Ensure that the modem is installed correctly.
- If the modem never worked in customer mode, ensure that all drivers are loaded correctly onto the computer.
- Ensure that the communication program is supported on the computer.
- Ensure that the public switch telephone network (PSTN) cable and the data access arrangement (DAA) cable, if installed, are connected correctly.

If you need to correct one of the above conditions, do so now; then continue.

Note: PCMCIA cards can be inserted and removed while the system is powered on.

- Power-on the system.
- Insert the IBM Data/FAX Modem diskette into the default diskette drive.
- If you are servicing a High Speed Internal Data/Fax Modem (Models FC3632 and FC3650), at the DOS prompt (for example, A:\), type **IBMDIAG**; then press **Enter**.
- If you are servicing a PCMCIA Data/FAX Modem (Models FC3634 and FC3635), at the DOS prompt (for example, A:\), type **ESTDIAG**; then press **Enter**.
- Follow the instructions on the screen. (If you need help, press **F1**.)

DID THE DIAGNOSTIC TESTS DETECT AN ERROR?

Yes No

002

The diagnostic tests have completed successfully. If you suspect a problem, go to Step 004.

003

Go to the Symptom-to-FRU Index for the computer you are servicing.

004

- Check the PSTN cable and the DAA cable, if installed, for continuity.

IS THE CABLE(S) GOOD?

Yes No

005

Replace the defective cable(s).

006

(Step **006** continues)

006 (continued)

– Have the customer transmit a call.

WAS THE CALL TRANSMITTED SUCCESSFULLY?

Yes No

007

Go to Step 011.

008

– Have the customer receive an incoming call on the modem.

WAS THE INCOMING CALL RECEIVED?

Yes No

009

Go to Step 014.

010

The diagnostic tests have completed successfully. If you still suspect a problem that is not software related, replace the External DAA; then replace the modem.

011

– Have the customer transmit a call at a lower speed.

WAS THE CALL TRANSMITTED SUCCESSFULLY?

Yes No

012

If installed, replace the external DAA. If you do not have an external DAA installed, or replacing the external DAA does not correct the problem, replace the modem.

013

Have the telephone line checked.

014

– Have the customer receive an incoming call on the modem at a lower speed.

WAS THE INCOMING CALL RECEIVED?

Yes No

015

If installed, replace the external DAA. If you do not have an external DAA installed, or replacing the external DAA does not correct the problem, replace the modem.

(CONTINUED)

016

Have the telephone line checked.

Printer Checkout

1. Make sure the printer is correctly connected and is powered-on.
2. Run the printer self-test.

If the printer self-test does not run correctly, the problem is in the printer. Refer to the printer service manual.

If the printer self-test runs correctly, do the following.

1. Verify the port settings in configuration.
2. Install a wrap plug on the port (indicated in configuration) and run the advanced diagnostic tests.
3. If the advanced diagnostic tests (with the wrap plug installed) do not detect a failure, replace the printer cable.

If the problem is not corrected, replace the system board.

Port Replicator Checkout

Use the following procedure to isolate a port replicator problem. A port replicator attaches to the system expansion connector at the rear of the computer.

1. Power-off the computer.
2. Remove the failing devices from the replicator.
3. Unplug the AC adapter from the replicator, if attached.
4. Remove the port replicator from the computer.
5. Reconnect the failing device directly to the computer. (If another device occupies the connector, remove it first.)
6. Go to General Checkout and follow that procedure.
7. If the advanced diagnostic device test does not find an error, suspect a problem with the port replicator or the system expansion bus.
8. Power-off the computer and reconnect the port replicator.
9. Power-on the computer and run the following advanced diagnostic tests:
 - Serial port test with the wrap plug installed on the replicator.
 - Parallel port test with the wrap plug installed on the replicator.
 - PCMCIA-2 test with the PC test card installed.
 - FDD-2 (FDD-1 if no drive is installed in the computer) drive test on the failing device.
10. If diagnostic errors appear, replace the replicator or diskette drive attachment unit.

If the problem remains after the replacement, replace the system board.
11. If power problems appear only when using the replicator, replace the replicator.

If power shut downs occur intermittently when using PCMCIA-2 devices via a port replicator, suspect an over-current problem. Some PCMCIA devices use more power; if the maximum usage of each device occurs simultaneously, the total current will exceed the limit, thereby causing a power shut down. Isolate this problem by removing one of the devices, and use the computer under the same condition, and see whether a power shut down occurs. Do this procedure for all devices then determine the cause. Customer purchase of the larger AC adapter (50W, optional) is recommended, if it is not yet in use.

TrackPoint II Checkout

- If the TrackPoint II does not work, check the configuration. If the configuration of the TrackPoint II is set to **Disabled** or **Off**, change it to **Enable** or **On**.

If the problem remains, continue.

Note: TrackPoint II automatically compensates to adjust the pointer sensor. This causes the pointer to move slightly on the screen and then stop. Pointer movement might occur when a slight, steady pressure is applied to the TrackPoint II pointer when the computer is powered-on or running, or when exceeded temperature range requires re-adjustment.

- If the cursor floats or moves erratically, power-off and disconnect the mouse. Power-on the computer. If the problem goes away, replace the mouse. If the problem remains, replace the keyboard.
- For click button or pointing stick problems:
 1. Go to the Easy-Setup screen.
 2. Select an item with the pointing stick.
 3. Press either left or right click button.
 4. Verify that both buttons work correctly.

If the pointing stick or the click button does not work, do the following.

1. Reseat the keyboard cables.
2. Replace the keyboard.
3. Replace the interposer card (355x, 360x, 750x, 755x).
4. Replace keyboard control card (720).
5. Replace the system board.

TV Tuner





The TV Tuner Pack (hereafter called TV Tuner) is an option for watching TV programs or videos on the IBM TFT color notebook computer. The computer changes to TV reception when the removable diskette drive is replaced with the TV Tuner.



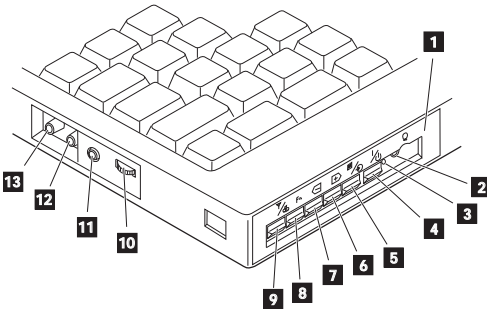

The TV screen and normal computer display are easily switched by using the Hot key on the front panel of the TV Tuner.

Identifying Names and Functions

The following figure and table show the names and functions of each part of the TV Tuner.







Icons	Functions
1 Front Panel	Used to change the TV channels, switch TV mode to computer mode, and operate most functions of the TV Tuner.
2 Headphone Jack 	Connects the headphones.
3 Power Indicator	Shows the TV Tuner is powered on.
4 Power Switch 	Powered on and off the TV Tuner.
5 Hot Key 	Switches between the TV screen and computer screen.
6 Up Switch 	Increases the value such as the channel number.
7 Down Switch 	Decreases the value such as the channel number.

Icons	Functions
8 Function Key Fn	Enters the mode to change the value of each function, such as TV channel or color contrast. (See "Using the Function Key" on page 479.)
9 TV/EXT Switch 	Switches the TV mode or external video mode.
10 Volume Knob 	Controls the speaker volume.
11 Audio-In Jack 	Connects the audio-in connector of the AV cable.
12 Video-In Jack 	Connects video-in connector of the AV cable.
13 RF Connector 	Connects the active antenna unit or antenna cable.

Using the Front Panel

The following table shows how to operate all functions of the TV Tuner with the controls on the front panel.

Key	Function
Power 	Turns on the TV Tuner. This key is used only when the computer is turned on.
Hot Key 	Switches computer display and TV screen.
Up 	Increases the value of parameters, Channel Number, Color, Tint, Brightness, Contrast, Auto Tuning Sensitivity, On-screen Message Selection.
Down 	Decreases the value of parameters, Channel Number, Color, Tint, Brightness, Contrast, Auto Tuning Sensitivity, On-screen Message Selection.
Function Fn	Selects a function mode to adjust each function parameter. (See "Using the Function Key" on page 479.)
TV/Ext 	Switches the displayed video source between the receiving TV broadcast program and external devices such as VCR, video camera recorder, laser disk, and so on.

Using the Function Key: Each time you press the Function key (F₁), one of the following messages (called *On-Screen Message*) appears at the top left corner of the LCD.

The changed values are automatically saved when you return to the “TV Channel” On-Screen message. The values are not saved when you power-off the TV Tuner without returning to this message.

Message on LCD	Parameter
(xx)	TV Channel By using ◀ and ▶, you can select the channels from 2 to 69.
COL	Color Adjustment By pressing and holding ◀ or ▶, you can change the color.
TNT	TINT Adjustment By pressing and holding ◀ or ▶, you can change the tint.
BRT	Bright Adjustment By pressing and holding ◀ or ▶, you can change the brightness.
CNT	Contrast Adjustment By pressing and holding ◀ or ▶, you can change the contrast.
---	(No function) Reserved.
LO HI	Auto Tune Sensitivity Selection LO: Means the sensitivity of the TV is low. In this mode, the TV Tuner receives strong TV signals only. To set LO, press ◀. HI: Means the sensitivity of the TV is high (factory default). In this mode, the TV Tuner receives weak and strong TV signals. To set HI, press ▶.
D3S DON	Time On-Screen Message appears D3S: On-Screen Message appears for 3 seconds. To set D3S, press ◀. DON: On-Screen Message always appears. To set DON press ▶.

Power-on the TV Tuner: Use the ThinkPad Features program or PS2.EXE. to power-on the TV Tuner; then power-on the internal device in the diskette drive compartment.

Warning

If power for the internal device is turned off when the TV Tuner is set up, nothing appears on the LCD display. Turn on power for the TV Tuner again.

- If you are using DOS, do one of the following:
 - Power-on the computer and type PS2 from the command prompt to start the ThinkPad Features program.
Select **Set Power Features** from the ThinkPad Features menu; then put a check mark at **Internal Serial Port** (or **Diskette Drive Compartment**) under the **Power for devices**. If you need help, press **F1** to display the help menu.
 - Type PS2 MODEM ON (or PS2 DDC ON) from the command prompt; press the Enter key to set the power ON.
- If you are using OS/2* or Microsoft Windows**, do the following:
 1. Power-on the computer and start the ThinkPad Features program.
 2. Select the **Power** icon; then move the pointer to **Internal Serial Port** (or **Diskette Drive Compartment**) under the **Power for devices** and click the button to check mark it.
 3. Press the **OK** button.

* Trademark of the IBM Corporation.

** Trademark of Microsoft Corp.

Troubleshooting

The following table shows what to do to solve problems when the TV Tuner does not work correctly.

Problem	Probable Cause
The TV Tuner does not operate. (No picture or sound)	<ul style="list-style-type: none"> • Computer is not powered on. • Computer is in suspend mode. • Volume control of the TV Tuner or computer is not adjusted correctly. • The power for the TV Tuner is not supplied. (See "Power-on the TV Tuner" on page 480.) • The wall outlet from the outdoor antenna is not active. • The video or antenna cable is not connected correctly. • Antenna elements of the active antenna unit are not adjusted. • The batteries in the active antenna unit are not inserted correctly. • The batteries in the active antenna unit are depleted. • The TV Tuner is not set up correctly. • You cannot watch TV or videos on the external display. • LO is set for the auto tune sensitivity selection. (See page 479.)
No color.	<ul style="list-style-type: none"> • The program is not in color.
Snow and noise only.	<ul style="list-style-type: none"> • Switch the TV/EXT () button.
Pictures are out of shape, or have double images.	<p>For TV:</p> <ul style="list-style-type: none"> • The channel is not tuned correctly. • Adjust the antenna. <p>For VCR:</p> <ul style="list-style-type: none"> • Change the tracking adjustment.
Dotted lines or stripes.	<ul style="list-style-type: none"> • Usually caused by interference from neon signs, hair dryers, and so on. Move the computer to avoid the interference.
Picture control are not saved.	<ul style="list-style-type: none"> • Do not power-off the TV Tuner when adjusting functions such as picture control, color, tint, brightness, or contrast.
Channel number is always displayed or is not displayed.	<p>Select your favorite mode for the on-screen message. (See page 479.)</p>

Common Parts Listing

This section contains FRUs common to most IBM portable, laptop, and notebook computers.

External Diskette Drives

5.25-Inch Diskette Drive:	
360KB External (4869-001)	72X6759
360KB External (4869-501)	72X6768
1.2MB External (4869-002)	15X7993
1.2MB External (4869-502)	15X7994
5.25-Inch Drive Adapter	72X6757
5.25-Inch Drive Adapter/A	15F7996
5.25-Inch External Diskette Drive Cable (from system board to adapter)	27F4211
Diskette Drive Bus Adapter	72X8524

CD-ROM Drives

Enhanced Internal CD-ROM II Drive (With eject button below slot)	61G1901
Internal CD-ROM I Drive (eject button above slot)	81F7930
Terminator Kit (for 81F7930)	59F3530
Cleaning Kit (for 81F7930) (Disks, CD Caddy)	59F3562
Internal CD-ROM II Drive (With eject button below slot)	92F0084
Terminator Kit (for 92F0084)	92F0082
Media Kit (for 92F0084) (no cleaning necessary, Test Disk, CD Caddy)	31F4232
Signal Cable	34F0043
Power Cable	72X8521
Remote ID Switch Cable (3510)	92F0086
Audio Card, Cable, Screws (3510)	92F0085
CD Caddy	22F9419
Rail Kit (3510)	34F0041
Headphones	53F3610

SCSI Adapters, Terminators, Cables

SCSI Adapter/A (without Cache)	85F0002
SCSI Internal Cable	64F4127
SCSI Adapter/A (with Cache)	85F0063
Terminator, External (for 85F0063)	33F8464
Terminator, Internal (for 85F0063)	34F0025
Terminator, Internal (for 85F0002)	57F2870
SCSI Fast Adapter (16 bit)	92F0330
SCSI External Cable (for 92F0330)	32G4089
SCSI Internal Cable (for 92F0330)	32G0084
Terminator, Inline (space permitting)	92F0412

Rewritable Optical Drives

3.5-Inch Rewritable Optical Drive	92F0167
Rewritable Optical Cartridge	38F8647
Rewritable Optical Cartridge (5 Pack)	38F8646
Drive Mounting Slide (for 92F0167)	85F0022
Tray with Bezel (for 92F0167)	85F0021
Objective Lens Cleaner (for 92F0167)	38F8681
Prism Lens Cleaner (for 92F0167)	38F8682
3.5-Inch Enhanced Rewritable Optical Drive	92F0167
Mounting Tray	92F0269
Mounting Tray/Bezel (Model 3510)	92F0268

External Keyboard/Mouse

Keyboard Cable	72X8537
Mouse	61X8923
Mouse Ball and Pop-Off Retainer	33F8461
Mouse Ball and Twist-Off Retainer	33F8462
Mouse (New Style)	33G5420
Mouse Retainer Ring	33G5417
Miniature Mouse	95F5723

Enhanced Keyboards (101/102 Key)

Country	
Arabic	1391490
Belgian	1391414
Canadian French	1392011
Cyrillic	1393866
Danish	1391407
Dutch	1391511
French	1391402
German	1391403
Greek	1393285
Hebrew	1391408
Italian	1393395
Latin American Spanish	1392015
Norwegian	1391409
Portuguese	1391410
Russian/Cyrillic	1395622
Spanish	1391405
Swedish/Finnish	1391411
Swiss	1391412
Swiss/French	1395881
Swiss/German	1395882
Turkish	1393286
U.K. English	1391406
U.S. English (E/ME/A use only)	1396790
U.S. English	1392090
Yugoslavian	1393669

Optional Enhanced Keyboards (101/102 Key)

with PS/2 Style Cable	59G7980
with AT Style Cable	59G7981
with 25mm PS/2 Trackball	59G7982
with 25mm Serial Trackball	59G9757

Keybutton Kits (101/102 Key)

Keybutton Kits (R), Belgian	1392033
Keybutton Kits (R), Canadian French	1392032
Keybutton Kits (R), Danish	1392026
Keybutton Kits (R), Dutch	1392034
Keybutton Kits (R), French	6447047
Keybutton Kits (R), German	6447048
Keybutton Kits (R), Italian	6447049
Keybutton Kits (R), Norwegian	1392028
Keybutton Kits (R), Portuguese	1392029
Keybutton Kits (R), Spanish	6447050
Keybutton Kits (R), Spanish / Latin	1392035
Keybutton Kits (R), Swedish	1392030
Keybutton Kits (R), Swiss / French / German	1392031
Keybutton Kits (R), U.K. English	6447046
Keybutton Kits, U.S. English	6447045

Japanese Keyboard Type 2 (106 Key, DBCS Support)

Japanese Keyboard	94X1110
Keyboard Cable	94X1147

Space-Saving Keyboards (84/85 Key)

Country	
Canadian French	1396046
Spanish/Latin	1396047
U.S. English	1393290
Cable Assembly, External	1393082

Tools and Miscellaneous

Audio Wrap Cable	66G5180
Ethernet BNC T-Connector	84F8207
Ethernet BNC 50-ohm Terminator (2 required)	85F0037
Grounding Wire Set	38F4684
Keyboard Key Cap Removal Tool	6110464
PC Test Card	33G4703
Screwdriver Kit	95F3598
SCSI Terminator (any SCSI device, space permitting)	92F0142
SCSI Terminator Kit (R-PAC Terminator Modules (3) for 40, 60, 80, 120, and 160MB SCSI Hard Disk Drives)	92F0143
Wrap Plug Ethernet D-Shell	85F0036
Wrap Plug, Tri-Connector	72X8546
Wrap Plug (6157 Tape Attachment Adapter/A)	4178459
Wrap Plug (Token-Ring Network Adapter/A)	6165899
Plastic Envelope (For Wrap Plug)	6138013

Display Power Cords

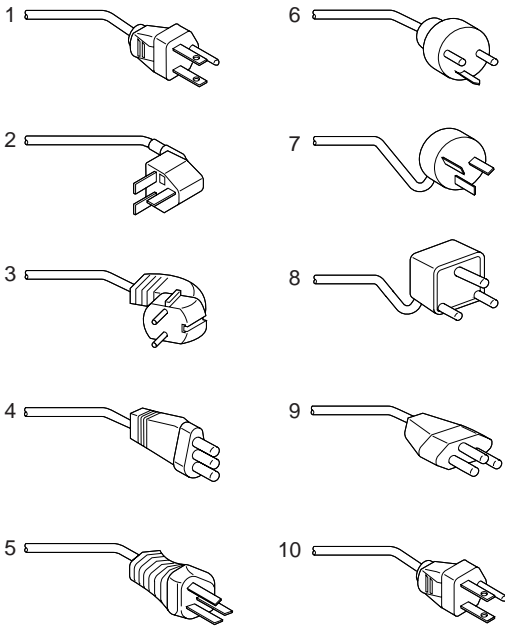

Index Country

1	Colombia, U.S., Venezuela	6952300
	Colombia, U.S., Venezuela	62X1045
2	Hong Kong, Singapore, U.K.	14F0033
3	France, Germany, Spain	13F9979
4	Italy, Chile	14F0069
5	Australia, New Zealand, New Guinea, Papua	13F9940
6	Denmark	13F9997
7	Israel	14F0087
8	Bangladesh, Pakistan, South Africa, Sri Lanka	14F0015
9	Switzerland	14F0051
10	Thailand	1838574
	Japan	79F2755

Element Exchange Displays

8503 12-Inch Monochrome Display

110/120 V ac	68X3045
220/240 V ac (No. Hemisphere)	68X3046
220/240 V ac (So. Hemisphere)	72X7878
Tilt/Swivel Stand	68X3061

8504 12-Inch Monochrome Display

110/120 or 220/240 V ac (Universal)	44F9807
220/240 V ac (No. Hemisphere)	44F9808
220/240 V ac (So. Hemisphere)	44F9809
Tilt/Swivel Stand	44F9820

8506 17-Inch Monochrome Display (with Tilt/Swivel Stand)

110/125 V ac (US/Canada)	39F8087
110/125 or 200/240 V ac (No. Hemisphere)	39F8091
110/125 or 220/240 V ac (So. Hemisphere)	39F8089

8507 19-Inch Monochrome Display

110/120 or 220/240 V ac (Universal Model)	6247808
110/125 or 200/240 V ac (No. Hemisphere)	6247843
110/125 or 220/240 V ac (So. Hemisphere)	6247842

8508 19-Inch Monochrome Display

110/125 V ac (US/Canada)	6247883
110/125 or 200/240 V ac (No. Hemisphere)	6247840
110/125 or 220/240 V ac (So. Hemisphere)	39F8068

8512 14-Inch Color Display

110/120 V ac (US/Canada)	61R8924
220/240 V ac (No. Hemisphere)	61X8928
220/240 V ac (So. Hemisphere)	61X8927
Tilt/Swivel Stand	61X8925

8513 12-Inch Color Display

110/120 V ac	68X3088
220/240 V ac (No. Hemisphere)	72X7870
220/240 V ac (So. Hemisphere)	72X7877
Tilt/Swivel Stand	68X3061

8514 16-Inch Color Display

110/120 V ac	75X5945
220/240 V ac (No. Hemisphere)	75X5946
220/240 V ac (So. Hemisphere)	75X5947
Tilt/Swivel Stand	75X5907

8515 14-Inch Color Display

90/137 V ac	07G4759
220/240 V ac (No. Hemisphere)	34G6628
220/240 V ac (Equatorial)	07G4762
220/240 V ac (So. Hemisphere)	07G4763
Tilt/Swivel Stand	38F3909

8516 Color Touch Display

110/120 V ac	44F9759
220/240 V ac (No. Hemisphere)	70F9129
220/240 V ac (So. Hemisphere)	70F9111

Miscellaneous Information

Acronyms, Abbreviations and Terms

Term	Information
ACPA/A	Audio Capture and Playback Adapter
ADP	Automatic Data Processing
Alt	Alternate
ANSI	American National Standards Institute
ARTIC	A Real Time Interface Coprocessor
ASCII	American National Standard Code for Interface Interchange
AT	Advanced Technology (as in AT Bus)
AVC	Audio Video Connection
BIOS	Basic Input/Output System (Controls System Resources)
bps	Bits Per Second
BPS	Bytes Per Second
CCITT	The International Telephone and Telegraph Consultative Committee
CCS	Common Command Set
CCSB	Common Complete Status Block
CCSB	Configuration Control Sub Board
CD	Compact Disc
CDPD	Cellular Digital Packet Data
CD-ROM	CD Read Only Memory (stores data/audio)
CE	Customer Engineer or Service Representative
CRC	Cyclic Redundancy Check
CRT	Cathode Ray Tube
CSD	Corrective Service Diskette
CGA	Color Graphics Adapter (See EGA, VGA, XGA)
CRC	Cyclic Redundancy Check
CRT	Cathode Ray Tube
CSA	Canadian Standards Association
CSD	Corrective Service Diskette
DASD	Direct Access Storage Device (hard disk, diskette)
DMA	Direct Memory Access
DRAM	Dynamic Random Access Memory
ECA	Engineering Change Announcement
ECC	Error Correction Code
EGA	Enhanced Graphics Adapter
ESD	Electrostatic Discharge
ESDI	Enhanced Small Device Interface
EEPROM	Electrically Erasable Programmable Read Only Memory
EWS	Energy Work Station
FRU	Field Replaceable Unit (replaceable part)
GPIB	General Purpose Interface Bus (IEEE 348)
GSA	General Services Administration
Ht	Height
IDE	Integrated Drive Electronics
IC	Integrated Circuit
IEEE	Institute of Electrical and Electronics Engineers
IEC	International Electrotechnical Commission
IML	Initial Machine Load
IPL	Initial Program Load
ISO	International Organization for Standardization
ISDN	Integrated-Services Digital Network

Term	Information
LAN	Local Area Network
LBA	Local Block Address
LTB	Local Transfer Bus
LUN	Logical Unit Number (as in SCSI)
MAP	Maintenance Analysis Procedure
MCGA	Modified Color Graphics Adapter (320 x 200 x 256)
MCA	Micro Channel Architecture (bus structure)
MHz	Mega hertz (millions of cycles per second)
MIDI	Musical Instrument Digital Interface
MM	Multimedia
N/A	Not Available or Not Applicable
NDD	National Distribution Division
NMI	Non-Maskable Interrupt
NSC	National Support Center
NVRAM	Non Volatile Random Access Memory
OEM	Original Equipment Manufacturer
PCMCIA	Personal Computer Memory Card International Association
POS	Programmable Option Select
PUN	Physical Unit Number (as in SCSI)
RAID	Redundant Array of Inexpensive Disks (disk array models)
RAM	Random Access Memory (read/write)
RGB	Red Green Blue (is in monitors)
RIPL	Remote Initial Program Load
ROM	Read Only Memory
SASD	Sequential Access Storage Device (Tape)
SCB	Subsystem Control Block
SCSI	Small Computer Systems Interface
SCSI ID	SCSI Identification Number (assigned device number)
SPD	Software Product Description
SR	Service Representative
SRAM	Static Random Access Memory
SVGA	Super Video Graphics Array
STN	Super Twisted Nematic
T/A	NDD Technical Advisor (See your Marketing Representative)
TDD	Telecommunications Device for the Deaf
TFT	Thin-Film Transistor
TPF	ThinkPad File
UL	Underwriters Laboratory
VCA	Video Capture Adapter
VESA	Video Electronics Standards Association
VGA	Video Graphics Array (640x480x16)
VPD	Vital Product Data
VRAM	Video Random Access Memory
WORM	Write Once, Read Many Media
XGA	Extended Graphics Array (1024 x 768 x 256)
Y/C	Luminance/Chrominance Signal (Pertains to Video)

Send Us Your Comments!

We want to know your opinion about this manual (part number 30H2357). Your input will help us to improve our publications.

Please photocopy this survey, complete it, and then fax it to **IBM HMM Survey at 919-543-8167 (USA)**.

Name _____

Phone Number _____

1. Do you like this manual?

- Yes No

2. What would you like to see added, changed, or deleted in this manual?

3. What is your service experience level?

- Less than five years
 More than five years

4. Which ThinkPad systems do you service most?

Thanks in advance for your response!

Do You Need Technical References?

We have a wide range of hardware technical references that provide in-depth information about IBM personal computer products. Our Technical Reference Library includes information about:

- Micro Channel, Setup, and Subsystem Control Block architectures
- Common interfaces (including microprocessors, system timers, parallel and serial port controllers, keyboards and keystrokes, SCSI, DMA, video, and more)
- Specific Personal System/2 systems (including system board connectors, jumpers, memory subsystems, I/O subsystems, programming interfaces and registers, and error codes)
- Basic input/output system (BIOS)
- Options and adapters

For a free catalog of our current offerings, please photocopy this form, complete it, and then fax it to **Hardware Technical References at 919-543-8167 (USA)**.

I'd like a catalog of the IBM PC Company Hardware Technical Reference library.

Name _____

Address _____

City _____

State _____ Zip _____

Problem Determination Tips

Due to the variety of hardware and software combinations that can be encountered, use the following information to assist you in problem determination. If possible, have this information available when requesting assistance from Service Support and Engineering functions.

- Machine type and model
- Processor or hard disk upgrades
- Failure symptom
 - Do diagnostics fail?
 - What, when, where, single, or multiple systems?
 - Is the failure repeatable?
 - Has this configuration ever worked?
 - If it has been working, what changes were made prior to it failing?
 - Is this the original reported failure?
- Reference Diskette Version
 - Type and revision level
- Hardware configuration
 - Print out (print screen) configuration from Reference Diskette currently in use
 - BIOS level
- Operating system software
 - Type and revision level

Important

To eliminate confusion, identical systems are considered *identical* only if they:

1. Are the exact machine type and models
2. Have the same BIOS level
3. Have the same adapters/attachments in the same locations
4. Have the same address jumpers/terminators/cabling
5. Have the same software versions and levels
6. Have the same Reference Diskette (version)
7. Have the same configuration options set in the system
8. Have the same setup for the operation system control files

Comparing the configuration and software set-up between “working and non-working” systems will often lead to problem resolution.

Phone Numbers, U.S. and Canada

Before you place a call to the Support Center, refer to "Problem Determination Tips" on page 493.

U.S. Authorized Dealers or Servicers

Number	Information
919-517-0001	Bulletin Board Service - PC Company
800-937-3737	IBM Business Partner Education
800-426-2472	IBM Customer Engineer Technical Support
800-426-7763	IBM National Support Center
800-IBM-DEAL	IBM PartnerLink Technical Support
303-924-4015	IBM Part Number ID and Look Up
800-237-5511	IBM Software Defect Support (CSDs)
800-327-5711	IBM Software Ordering (publications)
800-426-1484	IBM Supplies Technical Hotline
800-759-7483	IBM Warranty Claims Center
800-342-6672	OS/2 Replacement Diskettes (problems during new system installation)

U.S. Customers and Helpware Subscribers

Number	Information
919-517-0001	Bulletin Board Service - PC Company
800-426-8322	Customer Education Business Unit
800-999-0052	Customized Operational Services
407-982-6408	Developers Assistance (HW & SW)
800-964-8523	End User Support
800-772-2227	HelpCenter*, HelpLearn*, and Customer Satisfaction Center
800-426-4238	HelpCenter* (TDD/ASCII)
800-742-2493	IBM Anti-Virus Services
800-447-4700	IBM Authorized Dealer Referrals
800-426-4238	IBM Customer Satisfaction Center (TDD/ASCII)
800-426-2468	IBM Dealer Referral (typewriters/printers)
800-426-2468	IBM Direct (supplies, education)
800-282-0226	IBM Field Television Network
800-426-3333	IBM Information Referral Service
800-IBM-SERV	IBM Service
800-426-7282	IBM Technical Manuals
800-426-9402 (Ext. 150)	Multimedia Information Center
800-241-1620	Multimedia Support
800-742-2493	Multivendor Consulting
800-342-6672	OS/2 Information Line
800-237-5511	OS/2 Support Center
800-237-5511	OS/2 Support Line

* Trademark of the IBM Corporation.

** Trademark of the Prodigy Services Company.

U.S. Customers and Helpware Subscribers

Number	Information
303-924-4125	Parts Information
800-284-5933	Prodigy** Service (link problems)
914-962-0310	Prodigy User Questions
800-237-4824	PS/2 Trade-In Program
	PS/2 Loan for Learning
	PS/2 Lease from IBM Credit
800-742-2943	Solution Validation Lab
800-547-1283	Technical Coordinator Program
	SystemXtra* for Personal Systems
	LAN Automated Distribution/2
	OS/2 Bulletin Board
	OS/2 Application Assistance Center
800-426-2622	Technical Services, Boca Raton (fee)
606-323-3000	Technical Support (typewriters/printers)
800-551-2832	Technical Solutions Magazine

IBM Canada Customer and Servicer Support

Number	Information
800-387-8343	Ambra Customer Support
800-668-5682	Ambra Business Partner Warranty Support
800-387-8343	Ambra Business Partner Parts/Warranty Claims
905-316-7952	Ambra Bulletin Board
800-661-PSMT	Business Partner Marketing Support
905-316-5556	Business Partner Marketing Support - Toronto
514-938-6048	Business Partner Marketing Support - French
800-465-6600	Customer Relations
905-316-6666	Customer Relations - Toronto
800-465-6666	Customer Service Dispatch
800-263-2769	Customer Service Parts
800-465-2222	Customer Support Center (ISC)
416-443-5701	Customer Service Repair Centre
800-465-7999	HelpClub* Registration
800-465-7999	IBM Direct
905-513-3367	IBM Certification Administrator
905-316-2683	IBM Certification Coordinator Mail to: IBM Certification 50 Acadia Drive Markham, Ontario L3R 0B3
800-465-3299	IBM HelpFax
905-316-3299	IBM HelpFax - Toronto
800-565-3344	IBM HelpPC
800-268-3100	IBM Information Network Support
905-474-6666	IBM Information Network Support - Toronto

IBM Canada Customer and Servicer Support

Number	Information
800-663-7662	Lexmark Product Information
800-263-2769	Parts Orders, Exchange or Emergency
416-443-5808 (Fax)	Parts Regular Orders, Exchange
416-443-5755	Parts Orders, Inquiries
514-938-3022	PC Co Bulletin Board - Montreal
905-316-4255	PC Co Bulletin Board - Toronto
604-664-6464	PC Co Bulletin Board - Vancouver
204-934-2735	PC Co Bulletin Board - Winnipeg
800-661-7768	PS Marketing Support (PSMT)
800-465-1234	Publications Ordering
416-513-3360	Service Announcement, HMS Manuals
416-513-3372 (Fax)	Service Announcement, HMS Manuals
905-316-4148	Service Management Support
905-316-4100 (Fax)	Service Management Support
905-316-4150	Service Manager
905-316-4100 (Fax)	Service Manager
905-316-4872	Service Quality Programs
905-316-4100 (Fax)	Service Quality Programs
800-661-2131	Skill Dynamics* (Education)
800-387-8483	PS/1 Warranty Service, Business Partner (DOAs)
800-565-3344	PS/1 Warranty Service, Customer Helpline
416-443-5835 (Fax)	Warranty Claim Fulfillment
905-316-2445	Warranty Claim Reimbursement
905-316-3515 (Fax)	Warranty Claim Reimbursement
416-443-5778	Warranty Claim Parts Inquiry
800-505-1855	Warranty Provider Support Hotline
416-946-1333	Warranty Provider Support - Toronto
800-267-7472	Warranty Service, ThinkPad

* Trademark of the IBM Corporation.

Notices

References in this publication to IBM products, programs, or services do not imply that IBM intends to make these available in all countries in which IBM operates. Any reference to an IBM product, program, or service is not intended to state or imply that only that IBM product, program, or service may be used. Subject to IBM's valid intellectual property or other legally protectable rights, any functionally equivalent product, program, or service may be used instead of the IBM product, program, or service. The evaluation and verification of operation in conjunction with other products, except those expressly designated by IBM, are the responsibility of the user.

IBM may have patents or pending patent applications covering subject matter in this document. The furnishing of this document does not give you any license to these patents. You can send license inquiries, in writing, to:

IBM Director of Licensing
IBM Corporation
500 Columbus Avenue
Thornwood, NY 10594
U.S.A.

Trademarks

The following terms, denoted by an asterisk (*) in this publication, are trademarks of the IBM Corporation in the United States and/or other countries:

AIX	AT
FaxConcentrator	HelpCenter
HelpClub	HelpLearn
HelpWare	IBM
Micro Channel	OS/2
Personal System/2	PS/2
PS/Note	Portmaster
Skill Dynamics	SystemXtra
ThinkPad	Trackpoint
TrackPoint II	XGA

The following terms, denoted by a double asterisk (**) in this publication, are trademarks of other companies:

ActionMedia	Intel Corporation
DCA	Digital Communications Associates Inc.
PCMCIA	Personal Computer Memory Card International Association
PenDOS	Communications Intelligence Corporation
PenPoint	GO Corporation
Prodigy	Prodigy Services Company
VESA	Video Electronics Standards Association

Intel is a trademark or registered trademark of Intel Corporation.



Part Number: 30H2357

Printed in U.S.A.

S82G-1502-03



Free Manuals Download Website

<http://myh66.com>

<http://usermanuals.us>

<http://www.somanuals.com>

<http://www.4manuals.cc>

<http://www.manual-lib.com>

<http://www.404manual.com>

<http://www.luxmanual.com>

<http://aubethermostatmanual.com>

Golf course search by state

<http://golfingnear.com>

Email search by domain

<http://emailbydomain.com>

Auto manuals search

<http://auto.somanuals.com>

TV manuals search

<http://tv.somanuals.com>