

PCI-X Dual Channel Ultra320 SCSI RAID Adapter

Installation and Using Guide

PCI-X Dual Channel Ultra320 SCSI RAID Adapter

Installation and Using Guide

Note

Before using this information and the product it supports, be sure to read the general information under "Product Warranties and Notices" included with your system unit.

Second Edition (August 2004)

Before using this information and the product it supports, read the information in "Safety Information" on page v and Appendix B, "Notices," on page 33.

A reader's comment form is provided at the back of this publication. If the form has been removed, address comments to Publications Department, Internal Zip 9561, 11501 Burnet Road, Austin, Texas 78758-3493. To send comments electronically, use this commercial internet address: aix6kpub@austin.ibm.com. Any information that you supply may be used without incurring any obligation to you.

© **International Business Machines Corporation 2003, 2004. All rights reserved.**

Note to U.S. Government Users Restricted Rights--Use, duplication or disclosure restricted by GSA ADP Schedule Contract with IBM Corp.

Contents

Safety Information	v
Handling Static Sensitive Devices	vii
About This Book	ix
ISO 9000	ix
Highlighting	ix
References to AIX and Linux Operating Systems	ix
Related Publications	ix
Trademarks	x
Chapter 1. Overview	1
Verifying Operating System Requirements	2
Using AIX	2
Using Linux	2
Chapter 2. Preparing for Installation	3
Checking Prerequisites	3
Using AIX	3
Using Linux	3
Preparing for a PCI Slot-Length Installation	3
Determining Your Cable Requirements	4
Internal Cabling	4
External Cabling	4
Chapter 3. Installing the Device Driver Software (AIX)	5
Chapter 4. Installing the PCI-X Dual Channel Ultra320 SCSI RAID Adapter (AIX)	7
Installing the Adapter	7
Connecting Internal SCSI Backplanes and Devices	7
Connecting External SCSI Storage Peripheral Devices	8
Chapter 5. Setting Up the PCI-X Dual Channel Ultra320 SCSI RAID Adapter (AIX)	9
Verifying the Installation	9
Verifying AIX Software Installation	9
Verifying Hardware Installation	9
Updating Hard Disk Drive and Adapter Microcode	10
Configuring the PCI-X Dual Channel Ultra320 SCSI RAID Adapter	10
Limit Adapter Speed Using the Maximum SCSI Bus Speed in MB/s	10
Wide Bus Enabled	11
Quick Arbitration and Select (QAS) Capability	11
Problem Determination	11
Chapter 6. Using Disk Arrays	13
Using AIX	13
Using Linux	13
Chapter 7. Installing and Setting Up Software for the PCI-X Dual Channel Ultra320 SCSI RAID Adapter (Linux)	15
Installing the PCI-X Dual Channel Ultra320 SCSI RAID Adapter using the ipr Device Driver	15
Connecting External or Internal Devices	15
Verifying the Installation	16
Verifying Linux Software Installation	16

Installing the Downloaded Device Driver and Utility Software	17
Verifying Hardware Installation.	18
Updating Hard Disk Drive and Adapter Microcode	20
Configuring the PCI-X Dual Channel Ultra320 SCSI Adapter.	20
Limit Adapter Speed Using the Maximum SCSI Bus Speed in MB/s	20
Wide Bus Enabled	21
Quick Arbitration and Select (QAS) Capability	21
Setting Bus Speed at Boot	21
Problem Determination	21
Installing the PCI-X Dual Channel Ultra320 SCSI RAID Adapter using the ibmsis Device Driver.	22
Installing the PCI-X Dual Channel Ultra320 SCSI RAID Adapter	22
Verifying the Installation	23
Updating Hard Disk Drive and Adapter Microcode	26
Configuring the PCI-X Dual Channel Ultra320 SCSI Adapter.	26
Problem Determination	27
Appendix A. Communications Statements	29
Federal Communications Commission (FCC) Statement	29
European Union (EU) Statement	29
International Electrotechnical Commission (IEC) Statement	29
United Kingdom Telecommunications Safety Requirements	29
Avis de conformité aux normes du ministère des Communications du Canada	30
Canadian Department of Communications Compliance Statement	30
VCCI Statement	30
Electromagnetic Interference (EMI) Statement - Taiwan	30
Radio Protection for Germany	30
Appendix B. Notices	33
Appendix C. Connecting SCSI Hard Disk Drives to the Adapter	35
Determining Current SCSI Hard Disk Drive Addresses	36
Appendix D. Connection Examples	37
Internal Hard Disk Drive Connection	37
Internal and Single External Storage Peripheral Connections	37

Safety Information

DANGER

An electrical outlet that is not correctly wired could place hazardous voltage on metal parts of the system or the devices that attach to the system. It is the responsibility of the customer to ensure that the outlet is correctly wired and grounded to prevent an electrical shock.

Before installing or removing signal cables, ensure that the power cables for the system unit and all attached devices are unplugged.

When adding or removing any additional devices to or from the system, ensure that the power cables for those devices are unplugged before the signal cables are connected. If possible, disconnect all power cables from the existing system before you add a device.

Use one hand, when possible, to connect or disconnect signal cables to prevent a possible shock from touching two surfaces with different electrical potentials.

During an electrical storm, do not connect cables for display stations, printers, telephones, or station protectors for communication lines.

Handling Static Sensitive Devices

Attention: Static electricity can damage this device and your system unit. To avoid damage, keep this device in its anti-static protective bag until you are ready to install it. To reduce the possibility of electrostatic discharge, follow the precautions listed below:

- Limit your movement. Movement can cause static electricity to build up around you.
- Handle the device carefully, holding it by its edges or its frame.
- Do not touch solder joints, pins, or exposed printed circuitry.
- Do not leave the device where others can handle and possibly damage the device.
- While the device is still in its anti-static package, touch it to an unpainted metal part of the system unit for at least two seconds. (This drains static electricity from the package and from your body.)
- Remove the device from its package and install it directly into your system unit without setting it down. If it is necessary to set the device down, place it on its static-protective package. (If your device is an adapter, place it component-side up.) Do not place the device on your system unit cover or on a metal table.
- Take additional care when handling devices during cold weather, as heating reduces indoor humidity and increases static electricity.

About This Book

This book provides information about installing the PCI-X Dual Channel Ultra320 SCSI RAID Adapter and device driver support software, as well as cabling requirements. Use this book in conjunction with your specific system unit and operating system documentation.

ISO 9000

ISO 9000 registered quality systems were used in the development and manufacturing of this product.

Highlighting

The following highlighting conventions are used in this book:

Bold	Identifies commands, subroutines, keywords, files, structures, directories, and other items whose names are predefined by the system. Also identifies graphical objects such as buttons, labels, and icons that the user selects.
<i>Italics</i>	Identifies parameters whose actual names or values are to be supplied by the user.
Monospace	Identifies examples of specific data values, examples of text similar to what you might see displayed, examples of portions of program code similar to what you might write as a programmer, messages from the system, or information you should actually type.

References to AIX and Linux Operating Systems

This document contains references to the AIX and Linux operating system. If you are using another operating system, consult the appropriate documentation for that operating system.

This document may describe hardware features and functions. While the hardware supports them, the realization of these features and functions depends upon support from the operating system. AIX and Linux provide this support. If you are using another operating system, consult the appropriate documentation for that operating system regarding support for those features and functions.

Related Publications

The following publications contain related information:

- System unit documentation for information specific to your hardware configuration
- Operating system documentation for information specific to your software configuration and disk arrays. If your operating system is AIX, refer to the *PCI-X SCSI RAID Controller Reference Guide for AIX*, order number SA23-1323. If your operating system is Linux, refer to the *PCI-X SCSI RAID Controller Reference Guide for Linux*, order number SA23-1327
- *PCI Adapter Placement Reference*, order number SA38-0538 (for the latest version, you may need to contact your marketing representative)

Trademarks

The following terms are trademarks of International Business Machines Corporation in the United States, other countries, or both:

- AIX
- AIX 5L
- @server
- pSeries
- RS/6000

Other company, product, and service names may be trademarks or service marks of others.

Chapter 1. Overview

The PCI-X Dual Channel Ultra320 SCSI RAID Adapter is a 133 MHz 64-bit PCI-X adapter. It allows you to connect SCSI hard disk drives in RAID 0, 5 and 10 configurations to system units with a Peripheral Component Interconnect (PCI) bus. RAID (Redundant Array of Independent Disks) provides a way to distribute stored data among two or more hard disk drives inside or attached to a host system. This adapter supports non-RAID disks formatted to 512 bytes/sector, RAID disks formatted to 522 bytes/sector, and other devices including tape and optical devices.

Note: This guide refers to various hardware and software features and functions. The support for these features and functions depends upon the limitations of your hardware and software. AIX and Linux support all functions mentioned. If you are using another operating system, consult the appropriate documentation for that operating system regarding support for the mentioned features and functions. This guide also uses the terms *channel* and *bus* interchangeably.

The PCI-X Dual Channel Ultra320 SCSI RAID Adapter has two channels, 0 and 1. Each channel has both an internal and an external connector. Only one internal or external connector can be used on each channel.

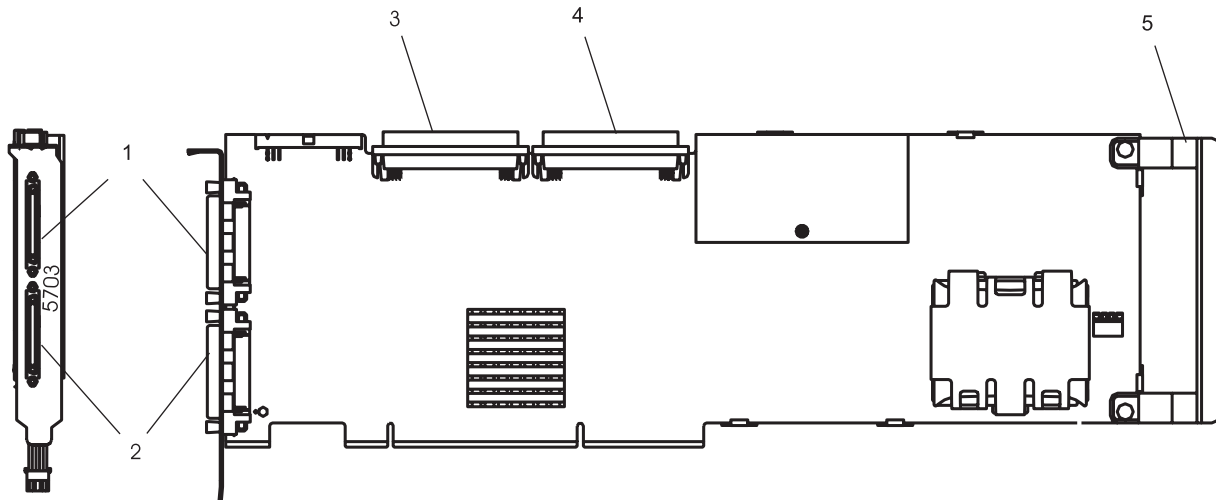

Figure 1. PCI-X Dual Channel Ultra320 SCSI RAID Adapter

- 1 Channel 1 external, 68-position, VHDCI (very high density cable interconnect)
- 2 Channel 0 external, 68-position, VHDCI (very high density cable interconnect)
- 3 Channel 0 internal, 68-position, high-density plastic D-shell SCSI standard connector for 16-bit attachment
- 4 Channel 1 internal, 68-position, high-density plastic D-shell SCSI standard connector for 16-bit attachment
- 5 Adapter Handle

You can create, control, and manage a RAID configuration in combination with supporting host software. For more RAID information, refer to the *PCI-X SCSI RAID Controller Reference Guide for AIX*, order number SA23-1323, or *PCI-X SCSI RAID Controller Reference Guide for Linux*, order number SA23-1327. The PCI-X Dual Channel Ultra320 SCSI RAID Adapter supports SCSI synchronous data rates from 20 MB/s (16-bit) up to 320 MB/s (16-bit) on two independent SCSI-2 channels.

If the AIX or Linux operating system is installed on a disk array, the RAID disk array may be used as the boot source.

You may receive this adapter preinstalled in a hot-swap carrier for use in certain system types. This carrier allows the adapter to be installed and removed without removing the top cover of the system. For handling instructions, refer to the user's guide for your system. If the adapter does not fit in your system, the handle may need to be removed in order for the adapter to fit properly. The handle can be removed by referring to "Preparing for a PCI Slot-Length Installation" on page 3.

The PCI-X Dual Channel Ultra320 SCSI RAID Adapter conforms to the American National Standards Institute (ANSI) SCSI-2 standard and the PCI local specification, revision 2.2.

Verifying Operating System Requirements

To ensure that your operating system will support the PCI-X Dual Channel Ultra320 SCSI RAID Adapter, use the following procedure to verify that your operating system requirements.

Using AIX

The PCI-X Dual Channel Ultra320 SCSI RAID Adapter is supported on the following levels of AIX or higher:

- AIX 5L Version 5.1 with the 5100-04 Recommended Maintenance Package (APAR IY44478)
- AIX 5L Version 5.2 with the 5200-01 Recommended Maintenance Package (APAR IY44479)

To determine which maintenance level is installed on your system, type `oslevel -r`. Verify that the maintenance level displayed is 5100-04, 5200-01, or higher. If no maintenance level is installed on your system, the following is an example of the data that displays on your screen:

```
No recommended maintenance level information is available.
```

If updates are needed, the latest maintenance packages and update instructions can be downloaded from the pSeries and RS/6000 Support Web site. The Web address is:

<http://techsupport.services.ibm.com/server/support>. Updates can also be ordered by calling IBM Support.

Using Linux

The PCI-X Dual Channel Ultra320 SCSI RAID Adapter is supported on the following Linux distributions:

- Any distribution based on United Linux 1.0 Service Pack 3, such as SuSE Linux Enterprise Server 8 Service Pack 3 or newer
- Red Hat Enterprise Linux 3 or newer
- SuSE Linux Enterprise Server 9 or newer

To determine which release is installed on your system, refer to your Linux distributor's documentation. If updates are needed, obtain them from your Linux distributor or download them from the IBM StorageIO Web Site. The Web address is: <http://www-124.ibm.com/storageio/ipr/>.

Note: SuSE Linux Enterprise Server 8 SP3 used the `ibmsis` device driver to control the PCI-X Dual Channel Ultra320 SCSI RAID adapter. This device driver has been replaced by the `ipr` device driver, which is used on all other supported distributions. Information on using the older `ibmsis` device driver is contained in "Installing the PCI-X Dual Channel Ultra320 SCSI RAID Adapter using the `ibmsis` Device Driver" on page 22. Refer to this section if you are still using this device driver.

Chapter 2. Preparing for Installation

This chapter helps you prepare to install the PCI-X Dual Channel Ultra320 SCSI RAID Adapter. Preparing to install the adapter involves the following tasks:

- Checking Prerequisites
- Preparing for a PCI Slot-Length Installation
- Determining Your Cable Requirements

Checking Prerequisites

To install the PCI-X Dual Channel Ultra320 SCSI RAID Adapter, you may need the following items:

- Your system unit installation guide
- IBM @server pSeries & RS/6000 Standalone Diagnostics CD-ROM (Version 5.2.0.11 or higher)
- Flat-blade screwdriver
- *PCI Adapter Placement Reference*, order number SA38-0538
- Documentation provided with your SCSI devices

Note: This adapter is supported on multiple systems and may require a system firmware update. Contact your service representative for further details.

To connect SCSI hard disk drives to the PCI-X Dual Channel Ultra320 SCSI RAID Adapter, you need the following cables:

- External cables (for attaching external storage devices or subsystems)
- An interposer cable, if required for external subsystem connections
- Internal cables (for attaching internal hard disk drives or backplanes)

Using AIX

In addition to the items listed above, this section includes AIX-specific items needed when preparing for installation.

- AIX 5.1 Update CD-ROM (Recommended Maintenance Package 5100-04 or higher)
- AIX 5.2 Update CD-ROM (Recommended Maintenance Package 5200-01 or higher)
- *PCI-X SCSI RAID Controller Reference Guide for AIX*, order number SA23-1323

Using Linux

In addition to the items listed above, this section includes Linux-specific items needed when preparing for installation.

- Linux Operating System CD-ROMs
- *PCI-X SCSI RAID Controller Reference Guide for Linux*, order number SA23-1327

Preparing for a PCI Slot-Length Installation

To prepare the PCI-X Dual Channel Ultra320 SCSI RAID Adapter for a PCI slot-length installation, do the following:

1. Remove the two screws that hold the handle to the adapter. Refer to Figure 1 on page 1.
2. Remove the handle from the adapter.

Determining Your Cable Requirements

You must use the correct SCSI cables to properly attach SCSI hard disk drives and subsystems.

If you install an Ultra320 SCSI hard disk drive or subsystem that can transfer data at up to 320 MB/s, the maximum cable length is limited to 20 meters (approximately 60 feet).

For more information about connecting SCSI hard disk drives to the PCI-X Dual Channel Ultra320 SCSI RAID Adapter, see Appendix C, "Connecting SCSI Hard Disk Drives to the Adapter," on page 35 and refer to the *PCI-X SCSI RAID Controller Reference Guide for AIX*, order number SA23-1323 or *PCI-X SCSI RAID Controller Reference Guide for Linux*, order number SA23-1327.

Internal Cabling

If you plan to install internal SCSI hard disk drives, you must obtain the necessary cables for your system unit. Refer to your system unit documentation for information about installing internal SCSI backplanes, hard disk drives, and cables.

A SCSI terminator must be located at the end of the internal cable. Terminators are built into the backplane within the computer.

External Cabling

External SCSI hard disk drives and subsystems have a variety of connectors. Ensure that you have cables with the correct connectors for each planned external SCSI attachment.

To externally attach hard disk drives and subsystems to the PCI-X Dual Channel Ultra320 SCSI RAID Adapter, you may need a 68-pin SCSI Very High Density Connector Interface to standard 68-pin SCSI standard connector interposer cable. In most cases, the cabling is delivered with the attaching subsystem.

Chapter 3. Installing the Device Driver Software (AIX)

The instructions in this chapter pertain to the AIX operating system.

Note: If you are using the Linux operating system, see Chapter 7, “Installing and Setting Up Software for the PCI-X Dual Channel Ultra320 SCSI RAID Adapter (Linux),” on page 15 for information regarding installing the device driver software and configuring your system. If you have another operating system installed, refer to your operating system documentation.

To install the device driver software, do the following:

1. Turn on the power to your system unit.
2. At the system prompt, log in as root user.
3. Insert the appropriate AIX 5.1 or 5.2 update CD-ROM into the media device.
4. To start SMIT, type:

```
smitty install_all
```

Press Enter.
5. The Install Additional Device Software window highlights the **INPUT device/directory for software** option.
6. Select or type the input device:
 - Press F4 to display the input device list. Select the name of the device (example: CD-ROM) that you are using and press Enter
 - OR
 - In the Entry Field, type the name of the input device you are using, and press Enter.
7. The INSTALL AND UPDATE FROM ALL AVAILABLE SOFTWARE window appears. Highlight the **SOFTWARE to install** option.
8. Press F4 to display a list of the device software you can install.
9. To display the Find window, type:
/
10. In the Find window, type:

```
devices.pci.14107802
```

Press Enter. The system finds and highlights this device software and displays output similar to the following example:

```
devices.pci.14107802          All
```
11. Press F7 to select the device software, and press Enter.
12. The INSTALL AND UPDATE FROM ALL AVAILABLE SOFTWARE window displays. Entry data fields are automatically updated. Highlight the **ACCEPT new license agreements?** option. Ensure that this option is set to **yes**. Press Enter to accept the data.
13. The ARE YOU SURE window displays. Press Enter to accept the data.
14. The **COMMAND STATUS** window displays.
 - The term RUNNING is highlighted to indicate that the install and configure command is in progress.
 - When RUNNING changes to OK, scroll down to the bottom of the page and locate the Installation Summary.
 - After a successful installation, SUCCESS appears in the Result column of the summary at the bottom of the page.
15. Remove the installation media from the drive.
16. Press F10 to exit SMIT.

Chapter 4. Installing the PCI-X Dual Channel Ultra320 SCSI RAID Adapter (AIX)

This chapter provides instructions for installing the PCI-X Dual Channel Ultra320 SCSI RAID Adapter and connecting your SCSI hard disk drives. Save this guide for future reference.

Note: If you are using Linux, see “Installing the PCI-X Dual Channel Ultra320 SCSI RAID Adapter using the ipr Device Driver” on page 15. If you have another operating system installed, refer to your operating system documentation for adapter installation information.

Attention

Be sure you have read “Handling Static Sensitive Devices” on page vii before handling your PCI-X Dual Channel Ultra320 SCSI RAID Adapter.

Installing the Adapter

To install the adapter, do the following:

1. Refer to the option installation documentation that shipped with your system unit to perform the following:
 - a. Some systems support the hot-plugging of adapters. Prepare your system to hot plug this adapter while system power is on. Shut down your system unit if your system does not support hot-plugging.
 - b. Install the PCI Adapter into your system unit.
2. To determine if any placement restrictions apply to your adapter, refer to the *PCI Adapter Placement Reference*. Return here to complete the installation procedure.

Attention

Failure to install your PCI adapter into the correct slot can cause your adapter or system unit to function incorrectly.

Connecting Internal SCSI Backplanes and Devices

To connect the internal hard-disk-drive backplanes or devices, do the following:

1. Stop the system and place it into the service position as described in the documentation provided with your system.
2. Set up and install your backplane or device with the power and signal connections as described in the documentation provided with your system.
3. The internal connectors for channel 0 and channel 1 are located on the top of the PCI-X Dual Channel Ultra320 SCSI RAID Adapter. These connectors are designed to fit one way only. Using the internal cable provided, connect one end of the cable to the internal connectors of the PCI-X Dual Channel Ultra320 SCSI RAID Adapter. Connect the other end of the cable to the appropriate backplane or device. The PCI-X Dual Channel Ultra320 SCSI RAID Adapter provides built-in terminators; therefore, terminators are not required at the end of the cable. Hard disk drives connect to the terminators that are built into the backplane.

Note: Do not attach any external subsystems to a channel if it is internally connected to a backplane.

4. Install all the internal SCSI (including non-RAID) devices by referring to the documentation provided with your device.

Important

After you connect the card, internal cables, and backplane, be sure to record which set of hard disk drives are connected to channels 0 and 1. The management software identifies the physical hard disk drives by channel and SCSI ID. To properly remove or add physical hard disk drives, you need the location of the hard disk drive that was removed from or added to the system.

5. Return the system to the operating position and start the system according to the instructions in your system unit documentation.

Connecting External SCSI Storage Peripheral Devices

After you install the PCI-X Dual Channel Ultra320 SCSI RAID Adapter and reinstall the cover of your system unit, you can connect the external storage peripheral devices. This adapter has two 68-pin Very High Density (VHD) connectors. If you are using a regular 68-pin cable, you may need an interposer cable.

Note: Attachment cables are usually shipped with the attaching storage peripheral device.

To connect external storage peripheral devices using the VHD interposer cable, do the following:

1. Connect the 68-pin VHD connector of the interposer cable to one of the external ports (channel 0 or 1) on this adapter. Use the fastening screws on the cable connector to securely attach the connector to the adapter.
2. Connect the other end of the VHD connector to the SCSI cable going to your external storage peripheral device.
3. Ensure that the external storage peripheral devices and system unit are powered on.

To connect external storage peripheral devices using a 68-pin Very High Density Cable Interconnection connector, do the following:

1. Connect one end of the 68-pin VHD connector to one of the external ports (channel 0 or 1) on this adapter. Use the fastening screws on the cable connector to securely attach the connector to the adapter.
2. Connect the other end of the 68-pin VHD cable to your external storage peripheral device.
3. Ensure that the external storage peripheral devices and system unit are powered on.

Notes:

- The SCSI channels 0 and 1 should never be interconnected. Each channel must operate independently.
- When you operate with more than one adapter in a system, you cannot share external hard disk drives between the adapters.

Chapter 5. Setting Up the PCI-X Dual Channel Ultra320 SCSI RAID Adapter (AIX)

This chapter provides AIX-specific hardware and software installation verification, adapter configuration, and problem-determination procedures.

Note: If you are using Linux, see “Verifying the Installation” on page 16. If you have another operating system installed, refer to your operating system documentation for information regarding configuring your system.

Verifying the Installation

Verify the initial installation by using the following procedures:

- Verifying AIX Software Installation (lspp)
- Verifying Hardware Installation (lsdev)

Verifying AIX Software Installation

To verify that the device driver software for the PCI-X Dual Channel Ultra320 SCSI RAID Adapter is installed, do the following:

1. If necessary, log in as root user.
2. Type:

```
lspp -l devices.pci.14107802*
```

Press Enter.

If the PCI-X Dual Channel Ultra320 SCSI RAID Adapter device driver software is installed, the following is an example of the data that displays on your screen:

```
devices.pci.14107802.diag 5.2.0.11 COMMITTED PCI-X Dual Channel Ultra320 SCSI RAID Adapter Diagnostics
devices.pci.14107802.rte 5.2.0.11 COMMITTED PCI-X Dual Channel Ultra320 SCSI RAID Adapter Software
devices.pci.14107802.unicode 5.2.0.0 COMMITTED PCI-X Dual Channel Ultra320 SCSI RAID Adapter Microcode
```

Note: The fileset number 5.2.0.11 displayed in the example might be different from the output displayed on your screen.

If no data displays on your screen, the PCI-X Dual Channel Ultra320 SCSI RAID Adapter device driver did not install. Return to Chapter 3, “Installing the Device Driver Software (AIX),” on page 5. Then continue with “Verifying Hardware Installation.”

If you continue to experience problems, it may be necessary to call your system support organization.

Verifying Hardware Installation

To verify that your system unit recognizes the PCI-X Dual Channel Ultra320 SCSI RAID Adapter, do the following:

1. If necessary, log in as root user.
2. Type:

```
lsdev -Cs pci | grep sisioa
```

Press Enter.

If the PCI-X Dual Channel Ultra320 SCSI RAID Adapter did install correctly, the following is an example of the data that displays on your screen:

```
sisioa0 Available 14-08 PCI-X Dual Channel U320 SCSI RAID Adapter
```

If the message on your screen indicates your adapter is Defined instead of Available, shut down your machine. Check the PCI-X Dual Channel Ultra320 SCSI RAID Adapter to ensure it is installed correctly. Go to Chapter 4, "Installing the PCI-X Dual Channel Ultra320 SCSI RAID Adapter (AIX)," on page 7, return to this section and repeat steps 1 and 2.

Note: If the message on your screen indicates your adapter is Defined a second time, it may be necessary to contact your service representative.

Updating Hard Disk Drive and Adapter Microcode

Disk drives attached to this RAID adapter must contain the latest microcode level.

The latest microcode level for your drive model and PCI-X Dual Channel Ultra320 SCSI RAID Adapter can be found at the Download pSeries and RS/6000 Microcode Updates Web site:

<https://techsupport.services.ibm.com/server/mdownload/download.html>.

The drive microcode download you need should match the name of one of the drive model numbers located under the DASD Microcode listing found on the Web site. The drive machine type and model of the drive you are updating can be identified by reading its VPD (Vital Product Data). Similarly, the name of the PCI-X Dual Channel Ultra320 SCSI RAID Adapter Microcode download you need can be found under the Adapter Microcode listing on the Web site.

Configuring the PCI-X Dual Channel Ultra320 SCSI RAID Adapter

The PCI-X Dual Channel Ultra320 SCSI RAID Adapter permits up to 320 MB/s operation with low voltage differential (LVD) devices on a wide bus. With single-end (SE) devices, it can run up to 40 MB/s. The maximum speed and bus width are automatically negotiated based on the characteristics of the attached device.

You can use SMIT to control speed and bus width for devices as described in the following sections.

Limit Adapter Speed Using the Maximum SCSI Bus Speed in MB/s

The default maximum adapter speed is 320 MB/s for LVD mode and 40 MB/s for SE mode. If you are not successful in running at these speeds, you can reduce the adapter speed.

To limit adapter speed, do the following:

1. At the command prompt, type `smit`, and press Enter.
2. Select **Devices** and press Enter.
3. Select **SCSI Adapter** and press Enter.
4. Select **Change/Show Characteristics of a SCSI Adapter** and press Enter.
5. Select your SCSI RAID adapter physical bus from the list and press Enter.

Note: This screen content varies based on the adapter that you select.

After making all desired changes in the entry fields, press Enter.

Change / Show Characteristics of a PCI-X SCSI RAID Controller Bus

	[Entry Fields]
SCSI Adapter	scsi5
Description	PCI-X U320 SCSI RAID>
Status	Available
Location	14-08-00
Adapter card SCSI ID	[7]
Wide bus enabled	yes
Maximum SCSI Bus Speed in MB/s	320
QAS (Quick Arbitration) Capability	Enable
Apply changes to DATABASE only	no

6. Select **Maximum SCSI Bus Speed in MB/s**.
7. Press F4.
8. Select the desired bus speed: **5, 10, 20, 40, 80, 160**, or **320** MB/s, and press Enter.
9. Press Enter again.
10. If the change was successful, press F10 to exit SMIT.

If you were not successful in using the procedure “Limit Adapter Speed Using the Maximum SCSI Bus Speed in MB/s” on page 10, do the following:

1. Select **Apply change to DATABASE only**.
2. Press F4 and select **yes**.
3. Press Enter.
4. Press F10 to exit SMIT.
5. At this point, the adapter and its child devices must be reconfigured. To reboot your system, log in as root user and type shutdown -Fr at the command prompt.

Wide Bus Enabled

If you are attaching an external device with an 8-bit SCSI interface cable, set **Wide bus enabled** to **no**. Follow the steps in “Limit Adapter Speed Using the Maximum SCSI Bus Speed in MB/s” on page 10.

Quick Arbitration and Select (QAS) Capability

The QAS capability is automatically controlled by the adapter.

Problem Determination

If you encounter any problems with the adapter after the installation, refer to your system unit documentation for information about running diagnostics or other problem-determination procedures. AIX users should refer to the *PCI-X SCSI RAID Controller Reference Guide for AIX*, order number SA23-1323.

Chapter 6. Using Disk Arrays

This chapter provides information about using the RAID-related features of this adapter. The following tasks are beyond the scope of this installation guide and are usually performed by system administrators.

- To use the RAID-related features of the hardware, disk arrays must be created first.
- AIX and Linux use and manage the disk array in the same way as it would a single non-RAID disk.
- For optimum performance, distribute the hard disk drives equally across the available channels.

Using AIX

For an overview of RAID and detailed procedures, refer to the *PCI-X SCSI RAID Controller Reference Guide for AIX*, order number SA23-1323.

- Disk drives previously installed in this system probably have 512 bytes/sector.
- To use the drives in disk arrays with this adapter, the disk drives must be prepared by formatting them to 522 bytes/sector.
- Disk drives in 512 bytes/sector format may continue to be used as standalone disks (that is, not part of a disk array) on this RAID adapter. Additionally, drives formatted to 522 bytes/sector may be reformatted to 512 bytes/sector at a later time if desired for compatibility with previous adapters.
- Formatting of drives to 522 bytes/sector and the creation of disk arrays may require that data previously written on the drives be saved and restored after the the disk arrays are created.
- If a disk array is to be used as the boot device, it may be required to prepare the disks by booting from the Diagnostic CD and creating the disk array before installing AIX. You might want to perform this procedure when the original boot drive is to be used as part of a disk array.

Using Linux

For an overview of RAID and detailed procedures, refer to the *PCI-X SCSI RAID Controller Reference Guide for Linux*, order number SA23-1327.

- Disk drives previously installed in this system are probably JBOD drives. JBOD drives are formatted to 512 bytes/sector.
- To use the drives in disk arrays with this adapter, the disk drives must be prepared by formatting them to 522 bytes/sector.
- Disk drives in 512 bytes/sector format may continue to be used as standalone disks (that is, not part of a disk array) on this RAID adapter. Additionally, drives formatted to 522 bytes/sector for advanced function may be reformatted to 512 bytes/sector at a later time if desired for compatibility with previous adapters.
- Formatting of drives to 522 bytes/sector for advanced function and the creation of disk arrays may require that data previously written on the drives be saved and restored after the disk arrays are created.
- If a disk array is to be used as the boot device, it may be required to prepare the disks by booting into rescue mode from the Linux CD first. If your Linux distribution does not provide this feature, the Diagnostic CD may be used. You might want to perform this procedure when the original boot drive is to be used as part of a disk array.

Chapter 7. Installing and Setting Up Software for the PCI-X Dual Channel Ultra320 SCSI RAID Adapter (Linux)

Previously, SuSE Linux Enterprise Server 8 SP3 used the `ibmsis` device driver to control the PCI-X Dual Channel Ultra320 SCSI RAID adapter. This device driver has been replaced by the `ipr` device driver, which is used on all other supported distributions. Information on using the `ibmsis` device driver has been retained in this chapter. If you are using the older `ibmsis` device driver, go to “Installing the PCI-X Dual Channel Ultra320 SCSI RAID Adapter using the `ibmsis` Device Driver” on page 22 and follow the procedures shown to install and set up the PCI-X Dual Channel Ultra320 SCSI RAID Adapter.

Note: If you are using AIX, see Chapter 5, “Setting Up the PCI-X Dual Channel Ultra320 SCSI RAID Adapter (AIX),” on page 9. If you have another operating system installed, refer to your operating system documentation for information regarding installing the device driver software and configuring your system.

Installing the PCI-X Dual Channel Ultra320 SCSI RAID Adapter using the `ipr` Device Driver

Install your PCI-X Dual Channel Ultra320 SCSI RAID Adapter using the instructions found in this section.

Note: If you are using AIX, follow the steps in Chapter 4, “Installing the PCI-X Dual Channel Ultra320 SCSI RAID Adapter (AIX),” on page 7.

Attention: Do not remove the PCI-X Dual Channel Ultra320 SCSI Adapter from its antistatic package at this time.

To install the adapter, do the following:

1. Refer to the option installation documentation that shipped with your system unit to perform the following:
 - a. Some systems support the hot-plugging of adapters. Prepare your system to hot plug this adapter while system power is on. Shut down your system unit if your system does not support hot-plugging.

Note: The 2.4 Linux kernel does not support PCI hot-plugging for SCSI host adapters.
 - b. To determine if any placement restrictions apply to your adapter, refer to the *PCI Adapter Placement Reference*. Return here to complete the installation procedure.
 - c. Install the PCI Adapter into your system unit.

Attention

Failure to install your PCI adapter into the correct slot can cause your adapter or system unit to function incorrectly.

Connecting External or Internal Devices

To connect external or internal devices, use the procedures in “Connecting Internal SCSI Backplanes and Devices” on page 7 or “Connecting External SCSI Storage Peripheral Devices” on page 8.

Note: Attachment cables are usually shipped with the attaching subsystem or device.

Verifying the Installation

Verify the initial installation by using the following procedures:

- Verifying Linux Software Installation
- Verifying Hardware Installation

Verifying Linux Software Installation

Software for the PCI-X Dual Channel Ultra320 SCSI RAID Adapter consists of a device driver and a set of utilities. This software is provided with the supported Linux distribution, and should have been installed along with the operating system.

Verify the initial software installation by using the following procedures:

- Verifying Device Driver Version (ipr)
- Verifying Utility Version (iprconfig)

Verifying Device Driver Version

The PCI-X Dual Channel Ultra320 SCSI RAID Adapter requires Version 1.0.3 (or later) of the **ipr** device driver for 2.4 based kernels and version 2.0.9 (or later) for 2.6 based kernels. To verify the version number of ipr, do the following:

For 2.6 Linux kernels:

1. If necessary, log in as root user.
2. Type:

```
modinfo ipr | grep version
```

Press Enter.

The following is an example of the data that displays on your screen:

```
version:          2.0.9 DA9C6A0AA78C5D2B9D947A1
```

For 2.4 Linux kernels:

1. If necessary, log in as root user.
2. Type:

```
modinfo ipr
```

Press Enter.

3. Type:

```
strings filename | grep "ipr version"
```

where *filename* is the file name displayed after the **modinfo** command was typed in the previous step. Press Enter.

The following is an example of the data that displays on your screen:

```
ipr version=Ver. 1 Rev. 0.3 SMP
```

Note: The version displayed in the example might be different from the output displayed on your screen.

If the version displayed is not at the recommended level and updates are needed, obtain them from your Linux distributor or download them from the IBM StorageIO Web site. The Web address is: <http://www-124.ibm.com/storageio/ipr/>.

Verifying Utility Version

The PCI-X Dual Channel Ultra320 SCSI RAID Adapter requires Version 1 of the **iprconfig** utility for 2.4 based kernels and version 2.x.x for 2.6 based kernels. To verify the version number of the **iprconfig** utility, do the following:

1. If necessary, log in as root user.
2. Type:

```
iprconfig --version
```

Press Enter.

The following is an example of the data that displays on your screen:

```
iprconfig: Ver. 1 Rev. 0.3  
iprconfig: 2.0.10 (May 23, 2004)
```

Note: The version displayed in the example might be different from the output displayed on your screen.

If the version displayed is not at the recommended level and updates are needed, obtain them from your Linux distributor or download them from the IBM StorageIO Web site. The Web address is: <http://www-124.ibm.com/storageio/ipr/>.

Installing the Downloaded Device Driver and Utility Software

Software required for the PCI-X Dual Channel Ultra320 SCSI RAID Adapter is usually installed when the Linux operating system is installed. Software installation is not necessary unless verification has failed.

If it is necessary to install software, obtain it from one of the following sources in the order listed:

1. Your supported Linux operating system CD-ROM
2. Your Linux distributor
3. Online at the IBM StorageIO Web site: <http://www-124.ibm.com/storageio/ipr/>

After downloading the needed software package, install the software by continuing with the instructions in this section. Then, return to “Verifying Linux Software Installation” on page 16, and follow the procedure to ensure that the installation was successful.

Installing Device Driver Software

The **ipr** device driver is available in the base 2.6 kernel as of version 2.6.7-rc1. Additional driver updates may be available on the IBM StorageIO Web site as mentioned above. These patches may be downloaded and installed like any other kernel patch. The **ipr** device driver is not in the base 2.4 kernel and must be downloaded from <http://www-124.ibm.com/storageio/ipr/> in the form of a kernel patch if not available as part of your distribution.

If you downloaded an **ipr** device driver patch, do the following:

1. Turn on the power to your system unit.
2. At the system prompt, log in as root user.
3. Uncompress and apply the patch by typing:

```
cd /usr/src/linux  
wget http://www-124.ibm.com/storageio/ipr/patch-2.4.26-ipr-1.0.5.gz
```

```
gunzip patch-2.4.26-ipr-1.0.5.gz  
patch -p1 < patch-2.4.26-ipr-1.0.5
```

Press Enter.

4. Compile and install the device driver. If you are compiling a 2.4 kernel, make sure **IBM Power RAID SCSI support** is selected. If you are compiling a 2.6 kernel, make sure **IBM Power Linux RAID adapter support** is selected.

5. To load the module, type:

```
modprobe ipr
```

Press Enter.

Note: If you are running a RHEL 3 based distribution, add the `modprobe ipr` line to the `/etc/rc.d/rc.local` file to ensure the driver is loaded at boot time.

Installing the Utility Software

If you downloaded the **iprutils** utility package, do the following:

1. Turn on the power to your system unit.
2. At the system prompt, log in as root user.
3. Install the following packages (if not already installed):

```
gcc
ncurses-devel
pciutils-devel
glibc-devel
```

4. Rebuild the **rpm** package by typing:

```
rpmbuild --rebuild --target ppc iprutils-2.0.10-1.src.rpm
```

Press Enter.

5. Install the compiled **rpm** package by typing:

```
rpm -Uvh iprutils-2.0.10-1.ppc.rpm
```

6. Restart the **iprutils** services by typing:

```
/etc/init.d/iprupdate restart
/etc/init.d/iprdump restart
```

7. If running a 2.6 kernel, restart the **iprinit** service by typing:

```
/etc/init.d/iprinit restart
```

Verifying Hardware Installation

To verify that your system unit recognizes the PCI-X Dual Channel Ultra320 SCSI RAID Adapter, do the following:

1. If necessary, log in as root user.
2. Type:

```
iprconfig
```

Press Enter.

3. Select the **Display hardware status** option and press Enter.

If the PCI-X Dual Channel Ultra320 SCSI RAID Adapter installed correctly, data displays for the adapter and each disk attached to it. The following is an example of the data that displays on your screen:

```

Display Hardware Status
Type option, press Enter.
  1=Display hardware resource information details

OPT Name  PCI/SCSI Location      Description              Status
-----
          0000:02:04.0.2/    PCI-X SCSI RAID Adapter Operational
          0000:02:04.0.2/1:14:0  Advanced Function Disk  Active
          0000:02:04.0.2/1:6:0   Advanced Function Disk  Active
          0000:02:04.0.2/1:8:0   Advanced Function Disk  Active
          0000:02:04.0.2/1:9:0   Advanced Function Disk  Active
sdt       0000:02:04.0.2/255:0:0  RAID 5 Disk Array       Active
          0000:02:04.0.2/1:10:0   RAID 5 Array Member     Active
          0000:02:04.0.2/1:11:0   RAID 5 Array Member     Active
          0000:02:04.0.2/1:12:0   RAID 5 Array Member     Active
          0000:02:04.0.2/1:13:0   RAID 5 Array Member     Active
sdb       0000:02:04.0.2/255:0:2  RAID 0 Disk Array       Active
          0000:02:04.0.2/1:4:0    RAID 0 Array Member     Active
sdc       0000:02:04.0.2/255:0:3  RAID 0 Disk Array       Active
          0000:02:04.0.2/1:3:0    RAID 0 Array Member     Active
sdd       0000:02:04.0.2/255:0:4  RAID 0 Disk Array       Active
More...

e=Exit  q=Cancel  r=Refresh  t=Toggle  f=PageDn  b=PageUp

```

If the message on your screen indicates your newly installed card, shown in the example as PCI-X SCSI RAID Adapter, is Not Operational instead of Operational or if it is not listed, shut down your machine. Go to “Installing the PCI-X Dual Channel Ultra320 SCSI RAID Adapter using the ipr Device Driver” on page 15 to ensure that the PCI-X Dual Channel Ultra320 SCSI RAID Adapter is installed correctly. Then return to this section, and repeat this hardware installation procedure.

Updating Hard Disk Drive and Adapter Microcode

Disk drives attached to this RAID adapter must contain the latest microcode level.

Microcode updates for hard disk drives attached to the PCI-X Dual Channel Ultra320 SCSI RAID Adapter are handled automatically by the **iprupdate** utility, which executes each time the system is booted, or manually by the **iprconfig** utility. The **iprupdate** utility will only automatically update microcode to adapters and devices if it is determined that they are not at the *minimum supported level* of microcode.

The latest microcode level for your drive model and PCI-X Dual Channel Ultra320 SCSI RAID Adapter may be shipped as part of the Linux distribution. If an update or replacement is needed, the latest microcode can be obtained from the pSeries microcode Web site:
<http://techsupport.services.ibm.com/server/mdownload/download.html>.

If you downloaded new microcode from the Web site, follow the instructions in the Readme on the Web site to install it. If there are no instructions available, install it as follows:

1. If necessary, log in as root user.
2. Install the **rpm** package by typing:

```
rpm -ivh --ignoreos scsi.0051.rpm
```

Press Enter.

3. Update the microcode based on your kernel type:
If you are using a 2.4 based kernel, type:

```
iprupdate
```

Press Enter. Once the microcode update has completed, you are finished.

If you are using a 2.6 based kernel, type:

```
iprconfig
```

Press Enter and go to the next step.

4. If you are using a 2.6 based kernel, choose the **Download microcode** menu option and:
 - Select the adapters and devices you wish to update
 - For each selected device, select the microcode image you wish to download

Configuring the PCI-X Dual Channel Ultra320 SCSI Adapter

The PCI-X Dual Channel Ultra320 SCSI Adapter permits up to 320 MB/s operation with LVD devices on a wide bus. With single-end (SE) devices, it can run up to 40 MB/s. The maximum speed and bus width are automatically negotiated based on the characteristics of the attached device.

You can use **iprconfig** to control speed and bus width for devices as described in the following sections.

Limit Adapter Speed Using the Maximum SCSI Bus Speed in MB/s

The default maximum adapter speed is 320 MB/s for LVD mode and 40 MB/s for SE mode. If you are not successful running at these speeds, you can reduce the adapter speed by changing the **Maximum Bus Throughput**.

Note: The device driver will default to 80 MB/s on the 2.4 kernel until the **iprupdate** utility runs and 160 MB/s on the 2.6 kernel until the **iprinit** utility is run. After the utilities complete, higher speeds will be attempted. These utilities are configured to run automatically each time the system is booted.

To limit adapter speed, do the following:

1. At the command prompt, type `iprconfig`, and press Enter.

2. If using iprconfig version less than 2.0.0, select **Work with configuration** and press Enter.
3. Select **Work with SCSI bus configuration** and press Enter.
4. Select your adapter from the list by pressing 1 then press Enter.

Note: This screen content varies based on the adapter that you select.

```

Change SCSI Bus Configuration

Current Bus configurations are shown. To change
setting hit "c" for options menu. Highlight desired
option then hit Enter

c=Change Setting

Adapter Location: 000:01:01.0

BUS 0
Maximum Bus Throughput . . : 320 MB/s    320 MB/s
BUS 1
Wide Enabled . . . . . : Yes           80 MB/s
Maximum Bus Throughput . . : 320 MB/s    40 MB/s
                                20 MB/s
                                10 MB/s
                                5 MB/s

Press Enter to Continue

e=Exit  q=Cancel

```

5. Select **Maximum Bus Throughput** field under the desired bus and press c.
6. Select the desired bus speed: **5, 10, 20, 40, 80, 160,** or **320** MB/s, and press Enter.

Note: Depending on your hardware, some of these options may not be available.

7. Press Enter to continue.
8. Press c to confirm the changes.

Wide Bus Enabled

If you are attaching an external device with an 8-bit SCSI interface cable, set **Wide bus enabled** to **no**. Follow the steps in “Limit Adapter Speed Using the Maximum SCSI Bus Speed in MB/s” on page 20.

Quick Arbitration and Select (QAS) Capability

The QAS capability is automatically controlled by the adapter.

Setting Bus Speed at Boot

If running a 2.6 kernel, a module parameter is provided to allow for setting the maximum bus speed at boot time before the **iprinit** utility runs. Normally this should not be needed, but if you are having difficulty booting due to running at 160 MB/s, bus speed can be lowered to 80 MB/s by using `ipr.max_speed=0` on the kernel command line.

Problem Determination

If you encounter any problems with the adapter after the installation, refer to your system unit documentation for information about running diagnostics or other problem-determination procedures. Refer to the *PCI-X SCSI RAID Controller Reference Guide for Linux*, order number SA23-1327.

Installing the PCI-X Dual Channel Ultra320 SCSI RAID Adapter using the ibmsis Device Driver

This chapter provides instructions for installing and verifying hardware and software that pertains to the Linux operating system using the `ibmsis` Device Driver. If you are using the newer `ipr` device driver, go to “Installing the PCI-X Dual Channel Ultra320 SCSI RAID Adapter using the `ipr` Device Driver” on page 15 and follow the procedures shown in that section.

Note: If you are using AIX, see Chapter 5, “Setting Up the PCI-X Dual Channel Ultra320 SCSI RAID Adapter (AIX),” on page 9. If you have another operating system installed, refer to your operating system documentation for information regarding installing the device driver software and configuring your system.

Installing the PCI-X Dual Channel Ultra320 SCSI RAID Adapter

Install your PCI-X Dual Channel Ultra320 SCSI RAID Adapter using the instructions found in this section.

Note: If you are using AIX, follow the steps in Chapter 4, “Installing the PCI-X Dual Channel Ultra320 SCSI RAID Adapter (AIX),” on page 7.

Attention: Do not remove the PCI-X Dual Channel Ultra320 SCSI Adapter from its antistatic package at this time.

To install the adapter, do the following:

1. Refer to the option installation documentation that shipped with your system unit to perform the following:
 - a. Some systems support the hot-plugging of adapters. Prepare your system to hot plug this adapter while system power is on. Shut down your system unit if your system does not support hot-plugging.

Note: The 2.4 Linux kernel does not support PCI hot-plugging for SCSI host adapters.
 - b. To determine if any placement restrictions apply to your adapter, refer to the *PCI Adapter Placement Reference*. Return here to complete the installation procedure.
 - c. Install the PCI Adapter into your system unit.

Attention

Failure to install your PCI adapter into the correct slot can cause your adapter or system unit to function incorrectly.

Connecting External or Internal Devices

To connect external or internal devices, use the procedures in “Connecting Internal SCSI Backplanes and Devices” on page 7 or “Connecting External SCSI Storage Peripheral Devices” on page 8.

Note: Attachment cables are usually shipped with the attaching subsystem or device.

Verifying the Installation

Verify the initial installation by using the following procedures:

- Verifying Linux Software Installation
- Verifying Hardware Installation

Verifying Linux Software Installation

Software for the PCI-X Dual Channel Ultra320 SCSI RAID Adapter consists of a device driver and a set of utilities. This software is provided with the supported Linux distribution, and should have been installed along with the operating system.

Verify the initial software installation by using the following procedures:

- Verifying Device Driver Version (ibmsis)
- Verifying Utility Version (sisconfig)

Verifying Device Driver Version: The PCI-X Dual Channel Ultra320 SCSI RAID Adapter requires Version 1 Revision 19 (or later) of the **ibmsis** device driver. To verify the version number of **ibmsis**, do the following:

1. If necessary, log in as root user.

2. Type:

```
modinfo ibmsis
```

Press Enter.

3. Type:

```
strings filename | grep "ibmsis version"
```

where *filename* is the file name displayed after the **modinfo** command was typed in the previous step. Press Enter.

The following is an example of the data that displays on your screen:

```
ibmsis version=Ver. 1 Rev. 19.10 SMP
```

Note: The version displayed in the example might be different from the output displayed on your screen.

If the version displayed is not at the recommended level and updates are needed, obtain them from your Linux distributor or download them from the IBM Support Web site. The Web address is: <http://www6.software.ibm.com/dl/linuxsdd/linuxsdd-p>.

Verifying Utility Version: The PCI-X Dual Channel Ultra320 SCSI RAID Adapter requires Version 1 Revision 19 (or later) of the **sisconfig** utility. To verify the version number of the **sisconfig** utility, do the following:

1. If necessary, log in as root user.

2. Type:

```
sisconfig --version
```

Press Enter.

The following is an example of the data that displays on your screen:

```
sisconfig: Ver. 1 Rev. 19.10
```

Note: The version displayed in the example might be different from the output displayed on your screen.

If the version displayed is not at the recommended level and updates are needed, obtain them from your Linux distributor or download them from the IBM Support Web site. The Web address is:
<http://www6.software.ibm.com/dl/linuxsdd/linuxsdd-p>.

Installing the Downloaded Device Driver and Utility Software

Software required for the PCI-X Dual Channel Ultra320 SCSI RAID Adapter is usually installed when the Linux operating system is installed. Software installation is not necessary unless verification has failed.

If it is necessary to install software, obtain it from one of the following sources in the order listed:

1. Your supported Linux operating system CD-ROM
2. Your Linux distributor
3. Online at the IBM Support Web site: <http://www6.software.ibm.com/dl/linuxsdd/linuxsdd-p>

After downloading the needed software package, install the software by continuing with the instructions in this section. Then, return to "Verifying Linux Software Installation" on page 23, and follow the procedure to ensure that the installation was successful.

Installing Device Driver Software: If you downloaded the **ibmsis** device driver package, do the following:

1. Turn on the power to your system unit.
2. At the system prompt, log in as root user.
3. If necessary, untar the device driver package. Type:

```
tar -xzvf ibmsis-$ver.tgz
```

Press Enter.
4. Compile and install the device driver. For instructions on how to compile and install the **ibmsis** device driver, see the Readme file located in **ibmsis/src/** directory.
5. To load the module, type:

```
modprobe ibmsis
```

Press Enter.

Note: If you are running a United Linux based distribution (such as SuSE) add the following line to the file **/etc/rc.d/boot.local** to ensure the driver is loaded at boot time: `modprobe ibmsis`

Installing the Utility Software: If you downloaded the **sisutils** utility package, do the following:

1. Turn on the power to your system unit.
2. At the system prompt, log in as root user.
3. If necessary, untar the utility package. Type:

```
tar -xzvf sisutils-$ver.tgz
```

Press Enter.
4. Compile and install the **sisutils** utility package. For instructions on how to compile and install the utility package, see the readme file located in the **sisutils/** directory.

Note: If you are running a United Linux based distribution (such as SuSE), add the following lines to the file **/etc/rc.d/boot.local** to ensure the driver is loaded at boot time:

```
sisdump &  
sisupdate
```

These lines should be added to the **/etc/rc.d/boot.local** file after the line `modprobe ibmsis`.

Verifying Hardware Installation

To verify that your system unit recognizes the PCI-X Dual Channel Ultra320 SCSI RAID Adapter, do the following:

1. If necessary, log in as root user.
2. Type:

```
sisconfig
```

Press Enter.
3. Select the **Display disk hardware status** option and press Enter.

If the PCI-X Dual Channel Ultra320 SCSI RAID Adapter installed correctly, data displays for the adapter and each disk attached to it. The following is an example of the data that displays on your screen:

```

Display Disk Hardware Status

Serial  Vendor  Product      Resource      Hardware
Number  ID       ID           Model        Name          Status
03000001 IBM     5703001     001         /dev/ibmsis0 Operational
000012F0 IBM     ST3146807LC 090         HS/Active
00001315 IBM     ST3146807LC 079         DPY/Active
000012F5 IBM     ST3146807LC 070         DPY/Active
00001304 IBM     ST3146807LC 079         DPY/Active
E7800377 IBM     01C933F1    205         /dev/sdc      Operational

Press Enter to continue.

e=Exit          q=Cancel      r=Refresh    f=PageDn    b=PageUp
d=Display disk unit details  p=Display device parity status

```

If the message on your screen indicates your newly installed card, shown in the example as `/dev/ibmsis0`, is `Not Operational` instead of `Operational` or if it is not listed, shut down your machine. Go to “Installing the PCI-X Dual Channel Ultra320 SCSI RAID Adapter using the ipr Device Driver” on page 15 to ensure that the PCI-X Dual Channel Ultra320 SCSI RAID Adapter is installed correctly. Then return to this section, and repeat this hardware installation procedure.

Updating Hard Disk Drive and Adapter Microcode

Disk drives attached to this RAID adapter must contain the latest microcode level.

Microcode updates for hard disk drives attached to the PCI-X Dual Channel Ultra320 SCSI RAID Adapter are handled automatically by the **sisupdate** utility, which executes each time the system is booted.

The latest microcode level for your drive model and PCI-X Dual Channel Ultra320 SCSI RAID Adapter is shipped as part of the Linux distribution. If an update or replacement is needed, the latest microcode can be obtained from your Linux distributor, or found as part of the device driver package at the following Web site: <http://www6.software.ibm.com/dl/linuxsdd/linuxsdd-p>.

If you downloaded new microcode from the Web site, install it as follows:

1. If necessary, log in as root user.
2. Untar the package, type:

```
tar -xzvf ibmsis-$ver.tgz
```

Press Enter.

3. Change directories to **ibmsis/obj/firmware/**. Type:

```
cd ibmsis/obj/firmware/
```

4. Install the microcode. Type:

```
make install
```

5. Update the microcode, type:

```
sisupdate
```

Press Enter.

Configuring the PCI-X Dual Channel Ultra320 SCSI Adapter

The PCI-X Dual Channel Ultra320 SCSI Adapter permits up to 320 MB/s operation with LVD devices on a wide bus. With single-end (SE) devices, it can run up to 40 MB/s. The maximum speed and bus width are automatically negotiated based on the characteristics of the attached device.

You can use **sisconfig** to control speed and bus width for devices as described in the following sections.

Limit Adapter Speed Using the Maximum SCSI Bus Speed in MB/s

The default maximum adapter speed is 320 MB/s for LVD mode and 40 MB/s for SE mode. If you are not successful running at these speeds, you can reduce the adapter speed by changing the **Maximum Bus Throughput**.

Note: The device driver will default to 80 MB/s until the **sisconfig** utility is run. After the **sisconfig** utility completes, higher speeds will be attempted. The **sisconfig** utility is configured to run automatically each time the system is booted.

To limit adapter speed, do the following:

1. At the command prompt, type **sisconfig**, and press Enter.
2. Select **Work with configuration** and press Enter.
3. Select **Work with SCSI bus configuration** and press Enter.
4. Select your adapter from the list by pressing 1 then press Enter.

Note: This screen content varies based on the adapter that you select.

```
Change SCSI Bus Configuration

Current Bus configurations are shown. To change
setting hit "c" for options menu. Highlight desired
option then hit Enter

c=Change Setting

/dev/ibmsis0
BUS 0
  Maximum Bus Throughput . . : 320 MB/s    320 MB/s
BUS 1
  Wide Enabled . . . . . : Yes           80 MB/s
  Maximum Bus Throughput . . : 320 MB/s    40 MB/s
                                   20 MB/s
                                   10 MB/s
                                   5 MB/s

Press Enter to Continue

e=Exit  q=Cancel
```

- 5. Select **Maximum Bus Throughput** field and under the desired bus and press c.
- 6. Press F4.
- 7. Select the desired bus speed: **5, 10, 20, 40, 80, 160,** or **320 MB/s**, and press Enter.

Note: Depending on your hardware, some of these options may not be available.

- 8. Press Enter to continue.
- 9. Press c to confirm the changes.

Wide Bus Enabled

If you are attaching an external device with an 8-bit SCSI interface cable, set **Wide bus enabled** to **no**. Follow the steps in "Limit Adapter Speed Using the Maximum SCSI Bus Speed in MB/s" on page 20.

Quick Arbitration and Select (QAS) Capability

The QAS capability is automatically controlled by the adapter.

Problem Determination

If you encounter any problems with the adapter after the installation, refer to your system unit documentation for information about running diagnostics or other problem-determination procedures. Refer to the *PCI-X SCSI RAID Controller Reference Guide for Linux*, order number SA23-1327.

Appendix A. Communications Statements

The following statement applies to this product. The statement for other products intended for use with this product appears in their accompanying documentation.

Federal Communications Commission (FCC) Statement

Note: This equipment has been tested and found to comply with the limits for a Class A digital device, pursuant to Part 15 of the FCC Rules. These limits are designed to provide reasonable protection against harmful interference when the equipment is operated in a commercial environment. This equipment generates, uses, and can radiate radio frequency energy and, if not installed and used in accordance with the instruction manual, may cause harmful interference to radio communications. Operation of this equipment in a residential area is likely to cause harmful interference in which case the user will be required to correct the interference at his own expense.

Properly shielded and grounded cables and connectors must be used in order to meet FCC emission limits. Neither the provider nor the manufacturer is responsible for any radio or television interference caused by using other than recommended cables and connectors or by unauthorized changes or modifications to this equipment. Unauthorized changes or modifications could void the user's authority to operate the equipment.

This device complies with Part 15 of the FCC Rules. Operation is subject to the following two conditions: (1) this device may not cause harmful interference, and (2) this device must accept any interference received, including interference that may cause undesired operation.

European Union (EU) Statement

This product is in conformity with the protection requirements of EU Council Directive 89/336/EEC on the approximation of the laws of the Member States relating to electromagnetic compatibility. The manufacturer cannot accept responsibility for any failure to satisfy the protection requirements resulting from a non-recommended modification of the product, including the fitting of option cards supplied by third parties. Consult with your dealer or sales representative for details on your specific hardware.

This product has been tested and found to comply with the limits for Class A Information Technology Equipment according to CISPR 22 / European Standard EN 55022. The limits for Class A equipment were derived for commercial and industrial environments to provide reasonable protection against interference with licensed communication equipment.

Attention: This is a Class A product. In a domestic environment this product may cause radio interference in which case the user may be required to take adequate measures.

International Electrotechnical Commission (IEC) Statement

This product has been designed and built to comply with IEC 60950.

United Kingdom Telecommunications Safety Requirements

This equipment is manufactured to the International Safety Standard EN60950 and as such is approved in the UK under the General Approval Number NS/G/1234/J/100003 for indirect connection to the public telecommunication network.

The network adapter interfaces housed within this equipment are approved separately, each one having its own independent approval number. These interface adapters, supplied by the manufacturer, do not use or contain excessive voltages. An excessive voltage is one which exceeds 70.7 V peak ac or 120 V dc. They

interface with this equipment using Safe Extra Low Voltages only. In order to maintain the separate (independent) approval of the manufacturer's adapters, it is essential that other optional cards, not supplied by the manufacturer, do not use main voltages or any other excessive voltages. Seek advice from a competent engineer before installing other adapters not supplied by the manufacturer.

Avis de conformité aux normes du ministère des Communications du Canada

Cet appareil numérique de la classe A est conforme à la norme NMB-003 du Canada.

Canadian Department of Communications Compliance Statement

This Class A digital apparatus complies with Canadian ICES-003..

VCCI Statement

<p>この装置は、クラス A 情報技術装置です。この装置を家庭環境で使用すると電波妨害を引き起こすことがあります。この場合には使用者が適切な対策を講ずるよう要求されることがあります。</p> <p>VCCI-A</p>

The following is a summary of the VCCI Japanese statement in the box above.

This is a Class A product based on the standard of the Voluntary Control Council for Interference by Information Technology Equipment (VCCI). If this equipment is used in a domestic environment, radio disturbance may arise. When such trouble occurs, the user may be required to take corrective actions.

Electromagnetic Interference (EMI) Statement - Taiwan

<p>警告使用者： 這是甲類的資訊產品，在居住的環境中使用時，可能會造成射頻干擾，在這種情況下，使用者會被要求採取某些適當的對策。</p>

The following is a summary of the EMI Taiwan statement above.

Warning: This is a Class A product. In a domestic environment this product may cause radio interference in which case the user will be required to take adequate measures.

Radio Protection for Germany

Dieses Gerät ist berechtigt in Übereinstimmung mit Dem deutschen EMVG vom 9.Nov.92 das EG-Konformitätszeichen zu führen.

Der Aussteller der Konformitätserklärung ist die IBM Germany.

Dieses Gerät erfüllt die Bedingungen der EN 55022 Klasse A. Für diese von Geräten gilt folgende Bestimmung nach dem EMVG:

Geräte dürfen an Orten, für die sie nicht ausreichend entstört sind, nur mit besonderer Genehmigung des Bundesministers für Post und Telekommunikation oder des Bundesamtes für Post und Telekommunikation betrieben werden. Die Genehmigung wird erteilt, wenn keine elektromagnetischen Störungen zu erwarten sind.

(Auszug aus dem EMVG vom 9.Nov.92, Para.3, Abs.4)

Hinweis

Dieses Genehmigungsverfahren ist von der Deutschen Bundespost noch nicht veröffentlicht worden.

Appendix B. Notices

This information was developed for products and services offered in the U.S.A.

The manufacturer may not offer the products, services, or features discussed in this document in other countries. Consult the manufacturer's representative for information on the products and services currently available in your area. Any reference to the manufacturer's product, program, or service is not intended to state or imply that only that product, program, or service may be used. Any functionally equivalent product, program, or service that does not infringe any intellectual property right of the manufacturer may be used instead. However, it is the user's responsibility to evaluate and verify the operation of any product, program, or service.

The manufacturer may have patents or pending patent applications covering subject matter described in this document. The furnishing of this document does not give you any license to these patents. You can send license inquiries, in writing, to the manufacturer.

The following paragraph does not apply to the United Kingdom or any country where such provisions are inconsistent with local law: THIS MANUAL IS PROVIDED "AS IS" WITHOUT WARRANTY OF ANY KIND, EITHER EXPRESSED OR IMPLIED, INCLUDING, BUT NOT LIMITED TO, THE IMPLIED WARRANTIES OF NON-INFRINGEMENT, MERCHANTABILITY OR FITNESS FOR A PARTICULAR PURPOSE. Some states do not allow disclaimer of express or implied warranties in certain transactions; therefore, this statement may not apply to you.

This information could include technical inaccuracies or typographical errors. Changes are periodically made to the information herein; these changes will be incorporated in new editions of the publication. The manufacturer may make improvements and/or changes in the product(s) and/or the program(s) described in this publication at any time without notice.

Information concerning products made by other than the manufacturer was obtained from the suppliers of those products, their published announcements, or other publicly available sources. The manufacturer has not tested those products and cannot confirm the accuracy of performance, compatibility or any other claims related to products made by other than the manufacturer. Questions on the capabilities of products made by other than the manufacturer should be addressed to the suppliers of those products.

Appendix C. Connecting SCSI Hard Disk Drives to the Adapter

The RAID adapter connects to a hard disk drive through one of two possible SCSI channels. The connected hard disk drives can be inside the host system unit, outside the system unit in a hard disk drive enclosure, or both. Each hard disk drive on a SCSI channel must have a unique SCSI ID of 0 through 6, 8, 9, A, B, C, D, E, or F.

The addressing scheme is in hex notation. Address 7 is reserved for the adapter and is not to be used for another SCSI hard disk drive. Each of the SCSI channels (0 and 1) is assigned a channel ID. The channel ID and SCSI ID are used to fully identify a hard disk drive connected to the adapter. For optimum overall performance and data protection, distribute hard disk drives evenly across the two available channels.

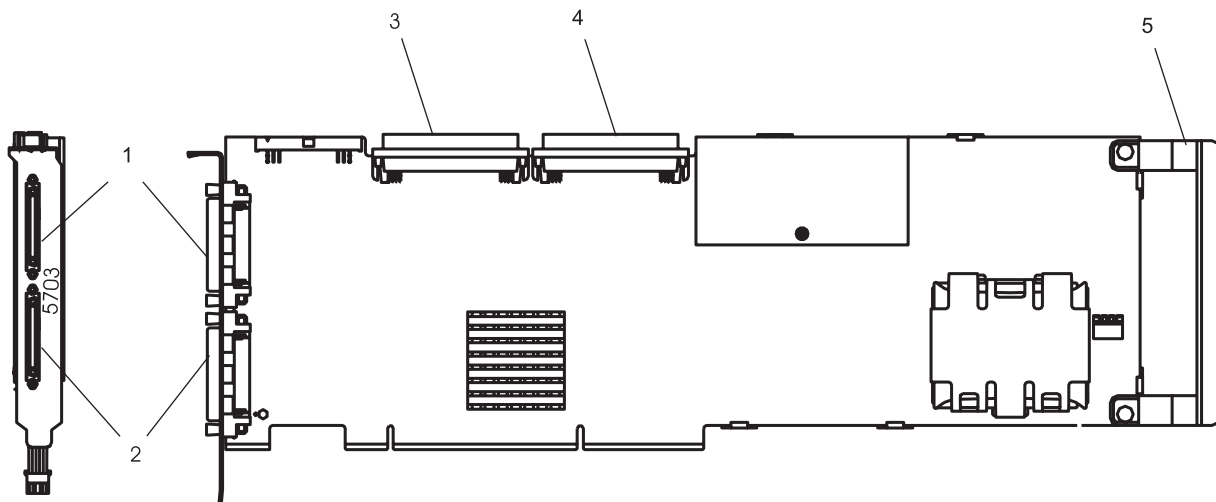

Figure 2. PCI-X Dual Channel Ultra320 SCSI RAID Adapter

- 1 Channel 1 external, 68-position, VHDCI (very high density cable interconnect)
- 2 Channel 0 external, 68-position, VHDCI (very high density cable interconnect)
- 3 Channel 0 internal, 68-position, high-density plastic D-shell SCSI standard connector for 16-bit attachment
- 4 Channel 1 internal, 68-position, high-density plastic D-shell SCSI standard connector for 16-bit attachment
- 5 Adapter Handle

Determining Current SCSI Hard Disk Drive Addresses

Hard disk drive backplanes or external subsystems automatically set the SCSI address for you. Refer to the documentation for your system or external subsystem for their locations. For future reference, be sure to keep a list of all the SCSI addresses you use and the channels to which they are connected.

To determine the SCSI addresses of any installed hard disk drives, start the RAID manager program and list the attached physical drives. For an AIX system, see *PCI-X SCSI RAID Controller Reference Guide for AIX*, order number SA23-1323. For a Linux system, see *PCI-X SCSI RAID Controller Reference Guide for Linux*, order number SA23-1327. If you have another operating system installed, refer to your operating system documentation for the correct procedures.

Notes:

1. The priority of SCSI addresses for the PCI-X Dual Channel Ultra320 SCSI RAID Adapter is not in sequential order. The order of priority is 7 through 0 and 15 through 8.
2. Address 7 is reserved for the adapter.

Appendix D. Connection Examples

This appendix provides examples of the different ways that you can connect SCSI hard disk drives to the PCI-X Dual Channel Ultra320 SCSI RAID Adapter.

Internal Hard Disk Drive Connection

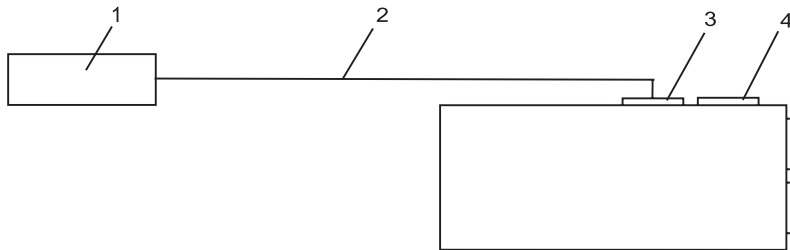

Figure 3. Internal Hard Disk Drive Connection

- 1 SCSI Hot Pluggable Backplane
- 2 System-Unique Internal Cable
- 3 Channel 1 68-pin SCSI Standard Internal Connector
- 4 Channel 0 68-pin SCSI Standard Internal Connector

Internal and Single External Storage Peripheral Connections

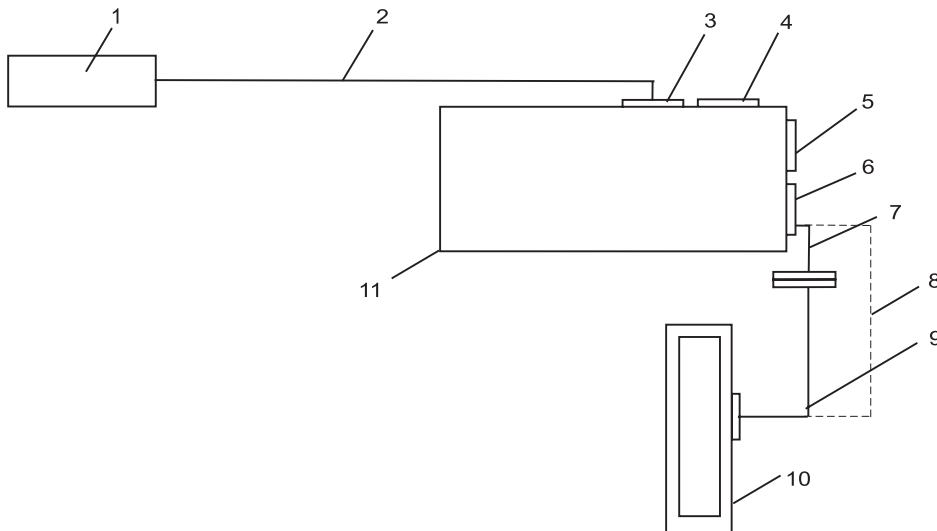

Figure 4. Internal and Single External Storage Connections

- 1 SCSI Hot Pluggable Backplane
- 2 System-Unique Internal Cable
- 3 Channel 1. 68-pin SCSI Standard Internal Connector
- 4 Channel 0. 68-pin SCSI Standard Internal Connector (VHDCI)

- 5 Channel 1. 68-pin SCSI Very High Density Connector Interface External Connector (VHDCI)
- 6 Channel 0. 68-pin SCSI Very High Density Connector Interface External Connector (VHDCI)
- 7 Interposer Cable FC 2118 (76H0518) for use only when cables with high-density connectors are available
- 8 Cable with two VHDCI connectors, which attaches the PCI-X Dual Channel Ultra320 SCSI RAID Adapter directly to the attaching subsystem enclosure. This cable is usually supplied with the subsystem enclosure.
- 9 Cable with two High Density Connectors, which is used with Interposer Cable FC 2118 (76H0518)
- 10 External Subsystem Enclosure
- 11 PCI-X Dual Channel Ultra320 SCSI RAID Adapter

Readers' Comments — We'd Like to Hear from You

PCI-X Dual Channel Ultra320 SCSI RAID Adapter
Installation and Using Guide

Publication No. SA23-1324-01

Overall, how satisfied are you with the information in this book?

	Very Satisfied	Satisfied	Neutral	Dissatisfied	Very Dissatisfied
Overall satisfaction	<input type="checkbox"/>	<input type="checkbox"/>	<input type="checkbox"/>	<input type="checkbox"/>	<input type="checkbox"/>

How satisfied are you that the information in this book is:

	Very Satisfied	Satisfied	Neutral	Dissatisfied	Very Dissatisfied
Accurate	<input type="checkbox"/>	<input type="checkbox"/>	<input type="checkbox"/>	<input type="checkbox"/>	<input type="checkbox"/>
Complete	<input type="checkbox"/>	<input type="checkbox"/>	<input type="checkbox"/>	<input type="checkbox"/>	<input type="checkbox"/>
Easy to find	<input type="checkbox"/>	<input type="checkbox"/>	<input type="checkbox"/>	<input type="checkbox"/>	<input type="checkbox"/>
Easy to understand	<input type="checkbox"/>	<input type="checkbox"/>	<input type="checkbox"/>	<input type="checkbox"/>	<input type="checkbox"/>
Well organized	<input type="checkbox"/>	<input type="checkbox"/>	<input type="checkbox"/>	<input type="checkbox"/>	<input type="checkbox"/>
Applicable to your tasks	<input type="checkbox"/>	<input type="checkbox"/>	<input type="checkbox"/>	<input type="checkbox"/>	<input type="checkbox"/>

Please tell us how we can improve this book:

Thank you for your responses. May we contact you? Yes No

When you send comments to IBM, you grant IBM a nonexclusive right to use or distribute your comments in any way it believes appropriate without incurring any obligation to you.

Name

Address

Company or Organization

Phone No.

Fold and Tape

Please do not staple

Fold and Tape



NO POSTAGE
NECESSARY
IF MAILED IN THE
UNITED STATES

BUSINESS REPLY MAIL

FIRST-CLASS MAIL PERMIT NO. 40 ARMONK, NEW YORK

POSTAGE WILL BE PAID BY ADDRESSEE

Information Development
Department H6DS-9561
11501 Burnet Road
Austin, TX 78758-3493

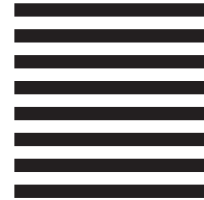

Fold and Tape

Please do not staple

Fold and Tape

Part Number: 80P5517

Printed in USA

SA23-1324-01



(1P) P/N: 80P5517



Free Manuals Download Website

<http://myh66.com>

<http://usermanuals.us>

<http://www.somanuals.com>

<http://www.4manuals.cc>

<http://www.manual-lib.com>

<http://www.404manual.com>

<http://www.luxmanual.com>

<http://aubethermostatmanual.com>

Golf course search by state

<http://golfingnear.com>

Email search by domain

<http://emailbydomain.com>

Auto manuals search

<http://auto.somanuals.com>

TV manuals search

<http://tv.somanuals.com>