

Self Checkout 4845



Parts Manual

Models 131, 15x, 171, 6xx, 8xx, and BW3



Self Checkout 4845



Parts Manual

Models 131, 15x, 171, 6xx, 8xx, and BW3

Note

Before using this information and the product it supports, be sure to read the “Safety ” on page vii and the general information under Appendix B, “Notices,” on page 125.

October 2007

- | This edition applies to IBM Self Checkout Solution, machine type 4845, Models 131, 151, 152, 153, and 171 and
- | IBM Self Checkout Systems, machine type 4845, Models 602, 603, 606, 612, 613, 616, 800, 810, and BW3.

Current versions of Retail Store Solutions documentation are available on the IBM Retail Store Solutions Web site at: www.ibm.com/solutions/retail/store/support. Click **Publications**.

A form for reader’s comments is also provided at the back of this publication. If the form has been removed, address your comments to:

IBM Corporation
Retail Store Solutions Information Development
Department ZBDA
PO Box 12195
Research Triangle Park, North Carolina, 27709 USA

When you send information to IBM, you grant IBM a nonexclusive right to use or distribute whatever information you supply in any way it believes appropriate without incurring any obligation to you.

© **Copyright International Business Machines Corporation 2006, 2007. All rights reserved.**

US Government Users Restricted Rights – Use, duplication or disclosure restricted by GSA ADP Schedule Contract with IBM Corp.

Contents

Preface	v
How to Use This Parts Manual	v
Identifying a Right Hand or Left Hand Model	v
Related Publications	vi
Where to Find More Information.	vii
Safety	vii
Publications Accessibility	vii
Providing Feedback	viii
Uninterruptible Power Supply Option	viii
Taiwanese Battery Recycling Statement.	viii
End of life disposal	viii
Chapter 1. Core Module	1
Assembly 1: Core Module	2
Assembly 2: Bill Dispenser	6
Assembly 3: Bill Dispenser Main Unit Illustration 1 of 3.	8
Assembly 4: Bill Dispenser Main Unit Illustration 2 of 3	10
Assembly 5: Bill Dispenser Main Unit Illustration 3 of 3	12
Assembly 6: Bill Dispenser Lower Unit	14
Assembly 7: Bill Dispenser Cassette	16
Assembly 8: Bill Dispenser Communications and Power.	18
Assembly 9: Coin Dispensers	20
Assembly 10: Coin Acceptor	24
Assembly 11: Bill Acceptor.	26
Assembly 12: Printers Tlx and TGx	28
Assembly 13: Printers TF6 and TM6	32
Assembly 14: Printers Fiscal	36
Assembly 15: Printers Epson.	38
Assembly 16: Magnetic stripe reader and pin pad mount	40
Assembly 17: Hand held scanner	42
Assembly 18: Countertop	44
Assembly 19: Signature Capture and Coupon Acceptor	46
Assembly 20: Lane light and transaction light.	48
Assembly 21: Lane PC, Mouse, and Keyboard	50
Chapter 2. Load Cells, Platens, Plates, and Retaining Fences	53
Assembly 22: Load Cell.	54
Assembly 23: Platens and Retaining Fences	56
Chapter 3. Security Conveyor	59
Assembly 24: Security Conveyor	60
Chapter 4. Transport Conveyor	63
Assembly 25: Transport Conveyor	64
Chapter 5. Bagging and Carousel Bagging	67
Assembly 26: Carousel parts	70
Chapter 6. Wire Bag Rack	73
Assembly 27: Wire Bag Rack	74
Chapter 7. BOSS	77
Assembly 28: BOSS FRUs	78

Chapter 8. Integrated Paystation	81
Assembly 29: Paystation	82
Chapter 9. EPO (Red) Button	85
Assembly 30: EPO (Red) Button	86
Chapter 10. Cables	89
Assembly 31: Cables.	90
Assembly 32: Power Cords	92
Chapter 11. Locks and Keys	95
Assembly 33: Currency Lock with Key	96
Assembly 34: Cabinet Lock with Key	98
Chapter 12. Field Kits and Tools	101
Assembly 35: Field Kits and Tools	102
Appendix A. Cabinet Parts and Sensors	105
Assembly 36: Core Module Cabinet FRUs	106
Assembly 37: Security Conveyor and Transport Conveyor Cabinet	110
Assembly 38: Models 152, 602, and 612 Bagging Cabinet	112
Assembly 39: Models 153, 603, and 613 Bagging Cabinet	114
Assembly 40: Model N54 Bagging Cabinet	116
Assembly 41: Models 171, 800, and 810 Bagging Cabinet	118
Assembly 42: Models 171, 800, and 810 Bumpers, Order Separators, Soft Goods Shelf	120
Assembly 43: Sensors, Emitters, and Detectors	122
Appendix B. Notices	125
Electronic emission notices	127
Federal Communications Commission (FCC) statement	127
European Union EMC Directive conformance statement	127
Industry Canada Class A Emission Compliance statement	128
Avis de conformité aux normes d'Industrie Canada	128
Germany	128
Australia and New Zealand	128
Japanese power line harmonics compliance statement.	128
Japanese Voluntary Control Council for Interference (VCCI) statement	129
Cable ferrite requirement.	129
Electrostatic Discharge (ESD)	129
Product Recycling and disposal	129
Battery return program	130
For Taiwan:	131
For the European Union:	131
For California:	131
Flat panel displays	132
Monitors	132
Trademarks.	132
Index	133
Part number index.	135

Preface

This parts manual lists the field replaceable units (FRUs) for the IBM Self Checkout Solution Models 131, 151, 152, 153, and 171 and the IBM Self Checkout Systems Models 602, 603, 606, 612, 613, 616, 800, 810, and BW3.

How to Use This Parts Manual

This manual is divided into the following components:

- **Core module.** See Chapter 1, “Core Module,” on page 1.
- **Load cell.** See Chapter 2, “Load Cells, Platens, Plates, and Retaining Fences,” on page 53.
- **Security conveyor.** See Chapter 3, “Security Conveyor,” on page 59.
- **Transport conveyor.** See Chapter 4, “Transport Conveyor,” on page 63.
- **Bagging module.** See Chapter 5, “Bagging and Carousel Bagging,” on page 67.
- **Wire Bag Rack.** See Chapter 6, “Wire Bag Rack,” on page 73.
- **BOSS.** See Chapter 7, “BOSS,” on page 77.
- **Paystation.** See Chapter 8, “Integrated Paystation,” on page 81.
- **EPO.** See Chapter 9, “EPO (Red) Button,” on page 85.
- **Cables.** See Chapter 10, “Cables,” on page 89.
- **Locks and keys.** See Chapter 11, “Locks and Keys,” on page 95.
- **Field kits.** See Chapter 12, “Field Kits and Tools,” on page 101.
- **Cabinet parts.** See Appendix A, “Cabinet Parts and Sensors,” on page 105.

Fasteners, screws, bolts, nuts, grommets and other miscellaneous parts are located in Chapter 12, “Field Kits and Tools,” on page 101.

Pictures in this manual are for reference only. The actual part might look different. When ordering, be sure to order the correct part using the machine type and model number.

Parts without index numbers or FRU numbers are shown for reference only. Some parts listed by FRU number are not pictured.

Identifying a Right Hand or Left Hand Model

Figure 1 on page vi shows a right-hand lane and a left-hand lane and gives the naming conventions used in this manual for referring to the sides of the lanes.

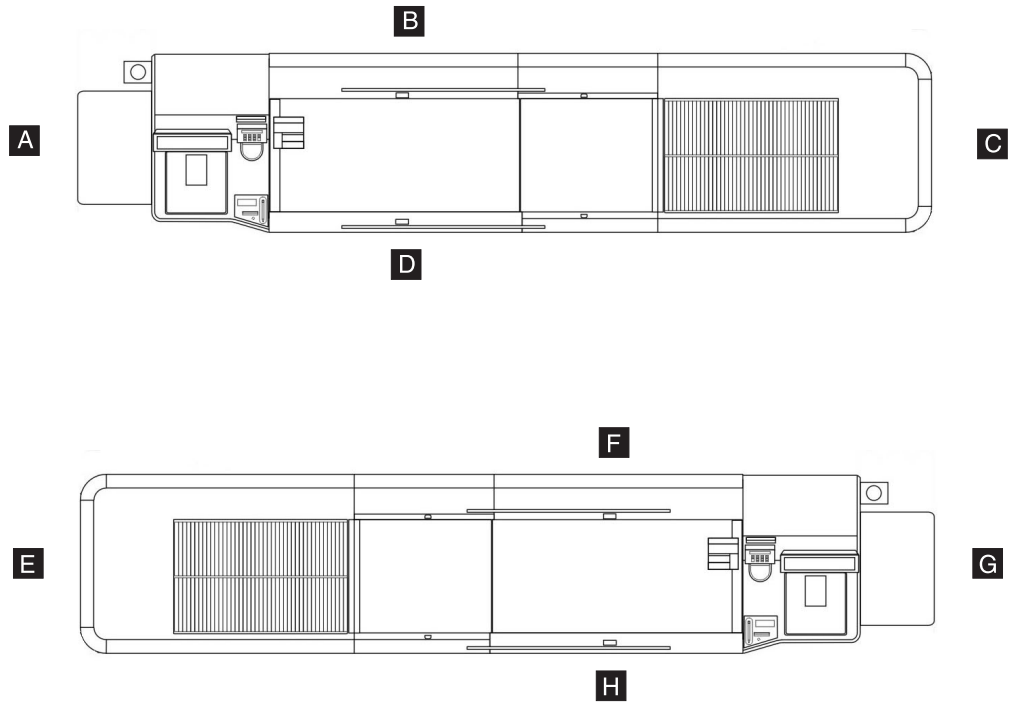

A	Start of right-hand lane.
B	Rear side (or left side relative to the transaction flow) of right-hand lane. The emitters are on the left side of the conveyor.
C	End of right-hand lane.
D	Front (customer side or right side relative to the transaction flow) of right-hand lane. The detectors are on the right side of the conveyor.
E	End of left-hand lane.
F	Rear side (or right side relative to the transaction flow) of left-hand lane. The detectors are on the right side of the conveyor.
G	Start of left-hand lane.
H	Front (customer side or left side relative to the transaction flow) of left-hand lane. The emitters are on the left side of the conveyor.

Figure 1. Right-Hand and Left-Hand Lanes

Related Publications

- *IBM Self Checkout 4845 Overview Models 131, 15x, 171, 6xx, 8xx and BW3, GC30-9732*
- *IBM Self Checkout 4845 Hardware Planning and Installation Guide Models 131, 15x, 171, 6xx, 8xx, and BW3, GC30-9733*
- *IBM Self Checkout Solution 4845 Operations Guide Models 131, 151, 152, 153, and 171, GA27-4341 (for software releases prior to Version 5 Release 2)*
- *IBM Self Checkout Solution 4845 Operations Guide Models 131, 151, 152, 153, and 171, with Version 5 Release 2 Software, GC30-9734*
- *IBM Self Checkout 4845 Operations Guide Models 6xx, 8xx, and BW3 with IBM Checkout Environment for Consumer-Service Version 6, GC30-9729*

- *IBM Self Checkout 4845 Hardware Service Guide Models 131, 15x, 171, 6xx, 8xx, and BW3, GY27-0442*
- *IBM Checkout Environment for Consumer-Service Software Planning, Installation, and Maintenance Guide for Version 6, SC30-4156*
- *IBM Checkout Environment for Consumer-Service Software Programming Guide for Version 6, SC30-4157*
- *IBM 4610 SureMark Printers Hardware Service Manual, GY27-0355*
- *IBM 4610 SureMark Printers User Guide, GA27-4151*
- *IBM 4820 SurePoint Solution Planning, Installation and Service Guide, GA27-4231*
- *IBM 4800 SurePOS 720, 740, and 780 Hardware Service Guide, SA27-4329*
- *IBM 4800 SurePOS 720, 740, and 780 Planning, Installation and Operation Guide, GA27-4328*
- *IBM 4694 Point-of-Sale Terminal Hardware Service Manual, SY27-0364*
- *IBM Safety and Regulatory Information - Read This First, GA27-4004*

Where to Find More Information

Current versions of Retail Store Solutions documentation are available on the IBM Retail Store Solutions Web site at www.ibm.com/solutions/retail/store. Select **Support**; then select **Publications**.

For information about publications not contained on the Web site, contact your IBM representative or your place of purchase.

Safety

Before you begin to install or service this product, read the safety information in the *IBM Safety and Regulatory Information - Read This First, GA27-4004*. This book describes the safe procedures for installing and servicing IBM products. In addition, read the following safety information.

DANGER

Electrical power must be removed before performing any maintenance or service on the self checkout product. See *IBM Self Checkout 4845 Hardware Service Guide Models 131, 15x, 171, 6xx, 8xx, and BW3, GY27-0442* for information about removing power.

DANGER

If the self checkout product is equipped with an uninterruptible power supply some devices are still energized after the removal of ac power. The uninterruptible power supply must be disconnected to ensure that all power is removed from the self checkout product.

Publications Accessibility

The soft-copy version of this guide and other related publications are accessibility-enabled.

Providing Feedback

Your feedback is important in helping IBM provide accurate and high-quality information.

You can use either of these ways to provide feedback:

- Go to <http://www.ibm.com/solutions/retail/store>. Click **Support**, then click **Publications**. Click the **publication comments** within the introductory text. Provide the requested information and your comments. Be sure to include the name and form number of the document in the [Publication ID] field.
- Print and complete the form at the end of this document. Return the form to IBM by mail or by giving it to an IBM representative.

If applicable, include a reference to the specific location of the text (for example, the page or table number) on which you are commenting.

Between major revisions of this document, there might be minor technical updates. The latest version of this document is available on the Retail Store Solutions Web site at <http://www.ibm.com/solutions/retail/store/support/publications/>.

Uninterruptible Power Supply Option

This product contains a sealed lead acid battery. The battery must be recycled or disposed of properly.

In the United States, IBM has established a collection process for reuse, recycling, or proper disposal of used IBM sealed acid batteries. For information about proper disposal of these batteries, please contact IBM at 1-800-426-4333. Please have the IBM part number listed on the battery available prior to your call.

For information about disposal of sealed acid batteries outside the United States, go to the following URL or contact your local waste disposal facility.

<http://www.ibm.com/ibm/environment/products/batteryrecycle.shtml>

Taiwanese Battery Recycling Statement

Waste batteries, please recycle.



End of life disposal

This unit must be recycled or discarded according to applicable local and national regulations. IBM encourages owners of information technology (IT) equipment to responsibly recycle their equipment when it is no longer needed. IBM offers a variety of product return programs and services in several countries to assist equipment owners in recycling their IT products. Information on IBM product recycling offerings can be found on IBM's Internet site at <http://www.ibm.com/ibm/environment/products/prp.shtml>.



Notice: This mark applies only to countries within the European Union (EU) and Norway.

Appliances are labeled in accordance with European Directive 2002/96/EC concerning waste electrical and electronic equipment (WEEE). The Directive determines the framework for the return and recycling of used appliances as applicable throughout the European Union. This label is applied to various products to indicate that the product is not to be thrown away, but rather reclaimed upon end of life per this Directive.

In accordance with the European WEEE Directive, electrical and electronic equipment (EEE) is to be collected separately and to be reused, recycled, or recovered at end of life. Users of EEE with the WEEE marking per Annex IV of the WEEE Directive, as shown above, must not dispose of end of life EEE as unsorted municipal waste, but use the collection framework available to customers for the return, recycling, and recovery of WEEE. Customer participation is important to minimize any potential effects of EEE on the environment and human health due to the potential presence of hazardous substances in EEE. For proper collection and treatment, contact your local IBM representative.

Disposal of IT products should be in accordance with local ordinances and regulations.

Chapter 1. Core Module

Assembly 1: Core Module	2
Assembly 2: Bill Dispenser	6
Assembly 3: Bill Dispenser Main Unit Illustration 1 of 3	8
Assembly 4: Bill Dispenser Main Unit Illustration 2 of 3	10
Assembly 5: Bill Dispenser Main Unit Illustration 3 of 3	12
Assembly 6: Bill Dispenser Lower Unit	14
Assembly 7: Bill Dispenser Cassette	16
Assembly 8: Bill Dispenser Communications and Power	18
Assembly 9: Coin Dispensers	20
Assembly 10: Coin Acceptor	24
Assembly 11: Bill Acceptor.	26
Assembly 12: Printers Tlx and TGx	28
Assembly 13: Printers TF6 and TM6	32
Assembly 14: Printers Fiscal	36
Assembly 15: Printers Epson.	38
Assembly 16: Magnetic stripe reader and pin pad mount	40
Assembly 17: Hand held scanner	42
Assembly 18: Countertop	44
Assembly 19: Signature Capture and Coupon Acceptor	46
Assembly 20: Lane light and transaction light	48
Assembly 21: Lane PC, Mouse, and Keyboard	50

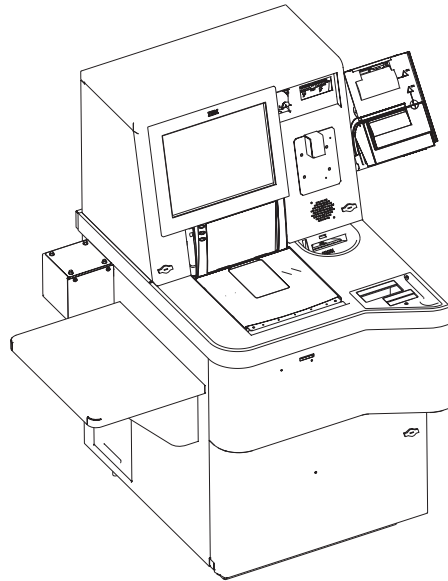

Assembly 1: Core Module

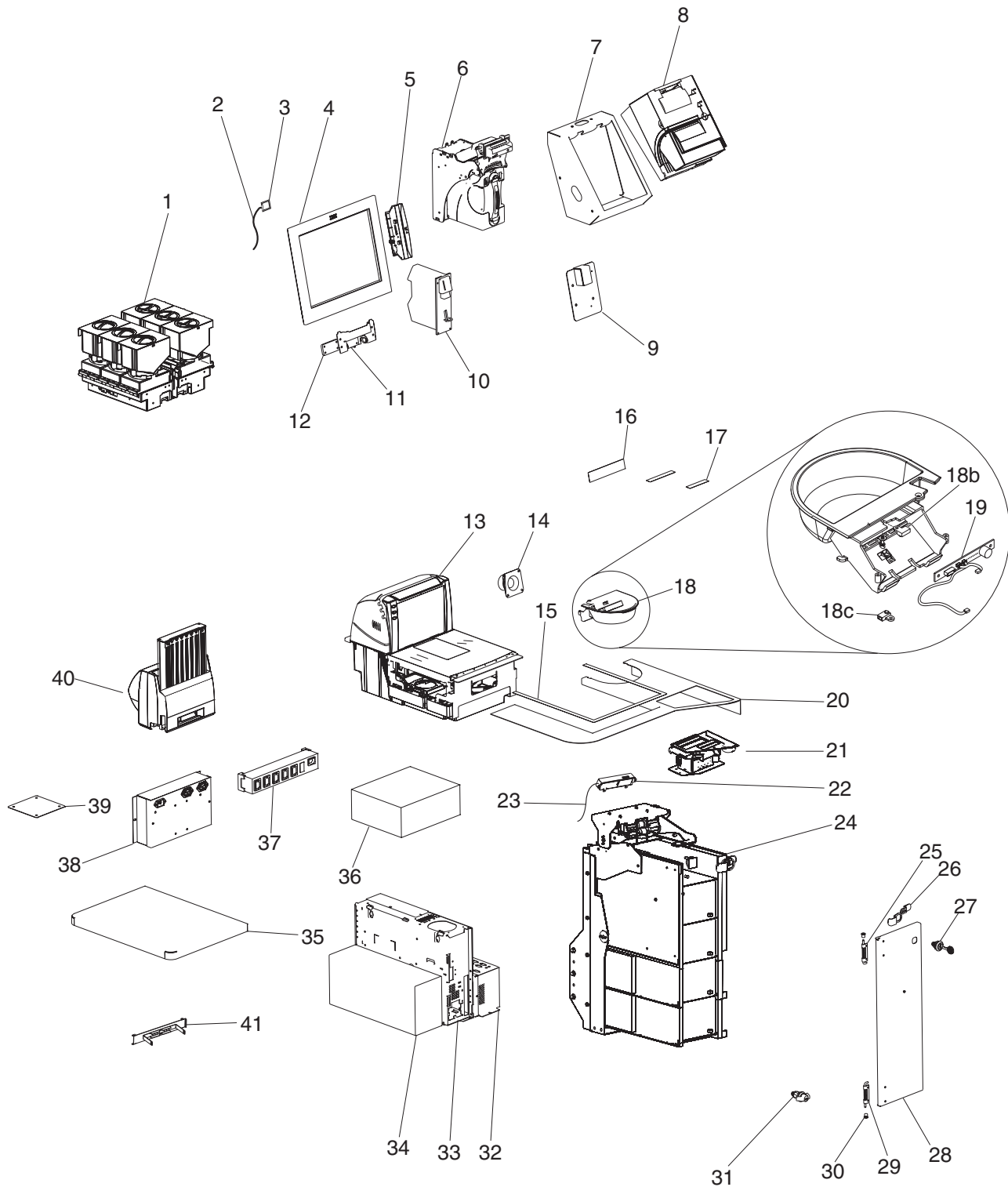

Asm-Index	Part Number	Units	Description
1-			See “How to Use This Parts Manual” on page v for general parts manual information, including finding and ordering parts. See “Identifying a Right Hand or Left Hand Model” on page v for how to identify left hand and right hand models.
-1		1	Hopper coin dispenser. See “Assembly 9: Coin Dispensers” on page 20 for a complete listing of coin dispenser parts.
-2	40M9470	1	Cable, Reset Button
-3	40M9469	1	Button Assembly, Reset (on upper door behind monitor)
-4	41J9296	1	Monitor, IBM SurePoint Model 4820 - 5WN (USB with I/O support), pearl white (BOSS) (machines built after July 31, 2006)
-4	40M9366	1	Monitor, IBM SurePoint Model 4820 - 5WN (USB with I/O support), pearl white (BOSS)
-4	41J9298	1	Monitor, IBM SurePoint Model 4820 - 5WN (USB without I/O support), pearl white (lane)
-4	41J9295	1	Monitor, IBM SurePoint Model 4820 - 5GN (USB with I/O support), iron gray (RAP/BOSS)
-4	41J9297	1	Monitor, IBM SurePoint Model 4820 - 5GN (USB without I/O support), iron gray (lane) (machines built after July 31, 2006)
-4	28R5455	1	Monitor, IBM SurePoint Model 4820 - 5GN (USB without I/O support), iron gray (lane)
-4	44M1846	1	Monitor, IBM SurePoint Model 4820 - 5GN (RS232 touch I/O), iron gray (EMEA)
-4	44D1157	1	Monitor, flat, T115 TFT, Model 4942 - 15X, black
-	14J1054	1	3.8 cable, Analog video Monitor, IBM SurePoint Model 4820.
-	42M5667	1	3.8 cable, Analog video Monitor, IBM SurePoint Model 4820 (machines built after July 31, 2006).
-	01L1637	1	3.8 cable, USB Touchscreen Monitor, IBM SurePoint Model 4820.
-	42M5632	1	3.8 cable, USB Touchscreen Monitor, IBM SurePoint Model 4820 (machines built after July 31, 2006).
-5	40N6220	1	Magnetic stripe reader, pearl white (attaches to the 4820 display)
-5	40N6224	1	Magnetic stripe reader, iron gray (attaches to the 4820 display)
-6		1	Bill acceptor assembly. See “Assembly 11: Bill Acceptor” on page 26 for a complete listing of bill acceptors and parts.
-7			See “Assembly 12: Printers Tlx and TGx” on page 28.
-8			See “Assembly 12: Printers Tlx and TGx” on page 28.
-9	41E1851	1	Cover plate if there is no pinpad (not shown)
-9			Magnetic strip reader mount and pin pad mounting. See “Assembly 16: Magnetic stripe reader and pin pad mount” on page 40).
-10		1	Coin acceptor. See “Assembly 10: Coin Acceptor” on page 24 for a complete listing of coin acceptors and parts.
-11	41E1849	1	SurePoint display hinge
-12	41E1850	1	Display mounting kit (includes 4 - shoulder washers, 8 - screws, 4 - M4 top inserts, 1 - spacer plate, 1 - limiter (right hand), and 1 - limiter (left hand).
-13		1	Scanner/scale (shown for reference only)
-	41D7211	1	Scanner Adapter plate, Fujitsu (customer furnished scanner)
-14	28R3786	1	Speaker
-14	41D7083	1	Speaker (machines built after July 31, 2006)
-	41K6370	1	Speaker Audio cable (not shown)
-15		1	Scanner/scale contrast label (shown for reference only)
-16	42K0356	1	Label, Cash Out, right hand
-16	42K0360	1	Label, Cash Out, left hand
-17	42K0358	1	Label, Coupon
-18	41J9839	1	Cash cup assembly, right hand
-18	41J9841	1	Cash cup assembly, left hand

Asm-Index	Part Number	Units	Description
-18	41K6356	1	Cash cup, left hand
-18	41K6355	1	Cash cup, right hand
-18B	41D7080	1	Detector, cash cup
-18C	41D7082	1	Emitter, cash cup
-19	41J9838	1	Sensor card, cash cup
-20		1	Countertop. See "Assembly 18: Countertop" on page 44 for a complete listing of available countertops.
-21		1	Signature capture device. See "Assembly 19: Signature Capture and Coupon Acceptor" on page 46 for a complete listing of signature capture parts.
-22	41J9916	1	Proximity sensor
-23	40M9472	1	Proximity sensor cable
-24		1	Bill dispenser assembly. See "Assembly 2: Bill Dispenser" on page 6.
-25	41D9329	1	Hinge, upper hinge for right hand door (lower hinge for the left hand door)
-26	41K6087	1	Safe door cam lock
-27	41K6120	1	Safe door lock, currency lock with key. See Chapter 11, "Locks and Keys," on page 95.
-28	41K6089	1	Safe door, right hand
-28	41K6090	1	Safe door, left hand
-29	41D9330	1	Hinge, lower hinge for the right hand door (upper hinge for the left hand door)
-30	41K6166	1	Bushing, hinge
-31		1	Keylock, cabinet lock with key. See Chapter 11, "Locks and Keys," on page 95.
-32	41J9135	1	Security controller
-33		1	Lane PC. See "Assembly 21: Lane PC, Mouse, and Keyboard" on page 50.
-34	41D9359	1	Uninterruptible power supply, 230V/400W (BK650EI) (machines built after July 31, 2006)
-34	41D7068	1	Uninterruptible power supply, 115V (replaces 28R3582) (SU620)
-	44D0872	1	APC RBC4 Uninterruptible power supply replacement battery (for SU620)
-	44D0874	1	APC RBC5 Uninterruptible power supply replacement battery (for SU700INET)
-	44D1125	1	APC RBC17 Uninterruptible power supply replacement battery (for BK650EI) (machines built after July 31, 2006)
-35	41K6161	1	Customer or basket shelf
-36		1	Sensormatic Scan Max Pro controller (shown for reference only)
-37	28R3587	1	Power strip, 5 Outlet, IEC320 (International, not US and Canada)
-	28R3595	1	Power strip, 115V, US, Canada, 8 outlet (not shown)
-	41D7775	1	Power strip IEC320 C-14 to 5 EU1-16R, French
-	44D0448	1	Power strip, IEC 60320 C-14 to 5 UK-13R
-38	41J9542	1	Filter/power box
-39	41E1865	1	Cover plate, lane light
-40		1	Cassette Coin dispenser. See "Assembly 9: Coin Dispensers" on page 20 for a complete listing of coin dispenser parts.
-41	41J9891	1	Bracket for vacuum florescent (VF) display (for some fiscal printers)
-	40N4716	1	3.8m Printer USB cable (not shown)
-	41K6369	1	PC Audio cable (not shown)
-	41D7073	1	Cable, 6 foot, DB9, male/female, used for uninterruptible power supply data (not shown)
-	41E1832	1	Power strip mounting plate (not shown)
-	28R3559	1	Power jumper cord, IEC 60320 C-14 to NEMA 5-15R (not shown)
-	39M5376	1	Power jumper cord, IEC320, 2-0M
-	41K6368	1	Power supply, Security controller (not shown)
-			See Appendix A, "Cabinet Parts and Sensors," on page 105 for available cabinet FRUs.
-			See Chapter 10, "Cables," on page 89 for additional cable FRUs.

Updated October 16, 2007

Assembly 2: Bill Dispenser

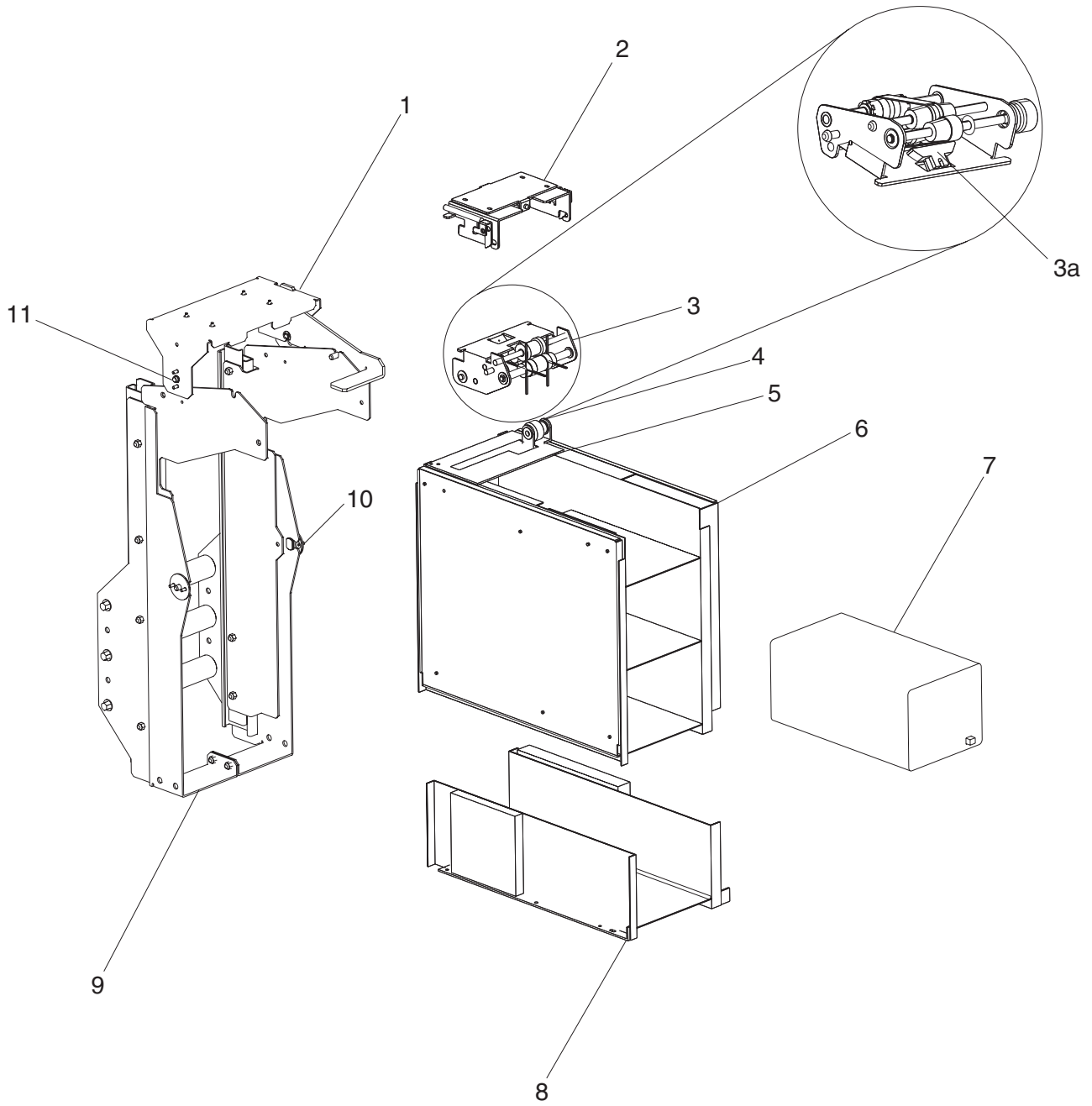

Asm- Index	Part Number	Units	Description
2-			See "How to Use This Parts Manual" on page v for general parts manual information, including ordering parts. See "Identifying a Right Hand or Left Hand Model" on page v for how to identify left hand and right hand models.
-1	41E1866	1	Bracket assembly, bill dispenser presenter mounting
-2	41K6318	1	Mount, bill dispenser (remains in cabinet)
-3	41K6319	1	Presenter, bill dispenser
-3A	41D7135	1	Sensor prism, presenter
-4	41D7137	1	Gear train, presenter gears
-5	41D7139	1	Presenter sensor plate
-6	41D7213	1	Bill dispenser, universal, 2 bin
-7	41D7053	1	Cartridge, universal, bill dispenser (includes configuration instructions and labels for each currency). See "Assembly 7: Bill Dispenser Cassette" on page 16 for additional component details.
-8	41D7215	1	Additional denomination module
-9	41K6398	1	Slide assembly, bill dispenser (with counter weight)
-10	41K6399	1	Mount parts, bill dispenser (pivot, screws, latch spring)
-11	41D8199	1	Set screw, bill dispenser presenter mount
-	41D7123	1	Presenter unit cable assembly (not shown)
-	41D7127	1	Presenter unit exit sensor (not shown)

Assembly 3: Bill Dispenser Main Unit Illustration 1 of 3

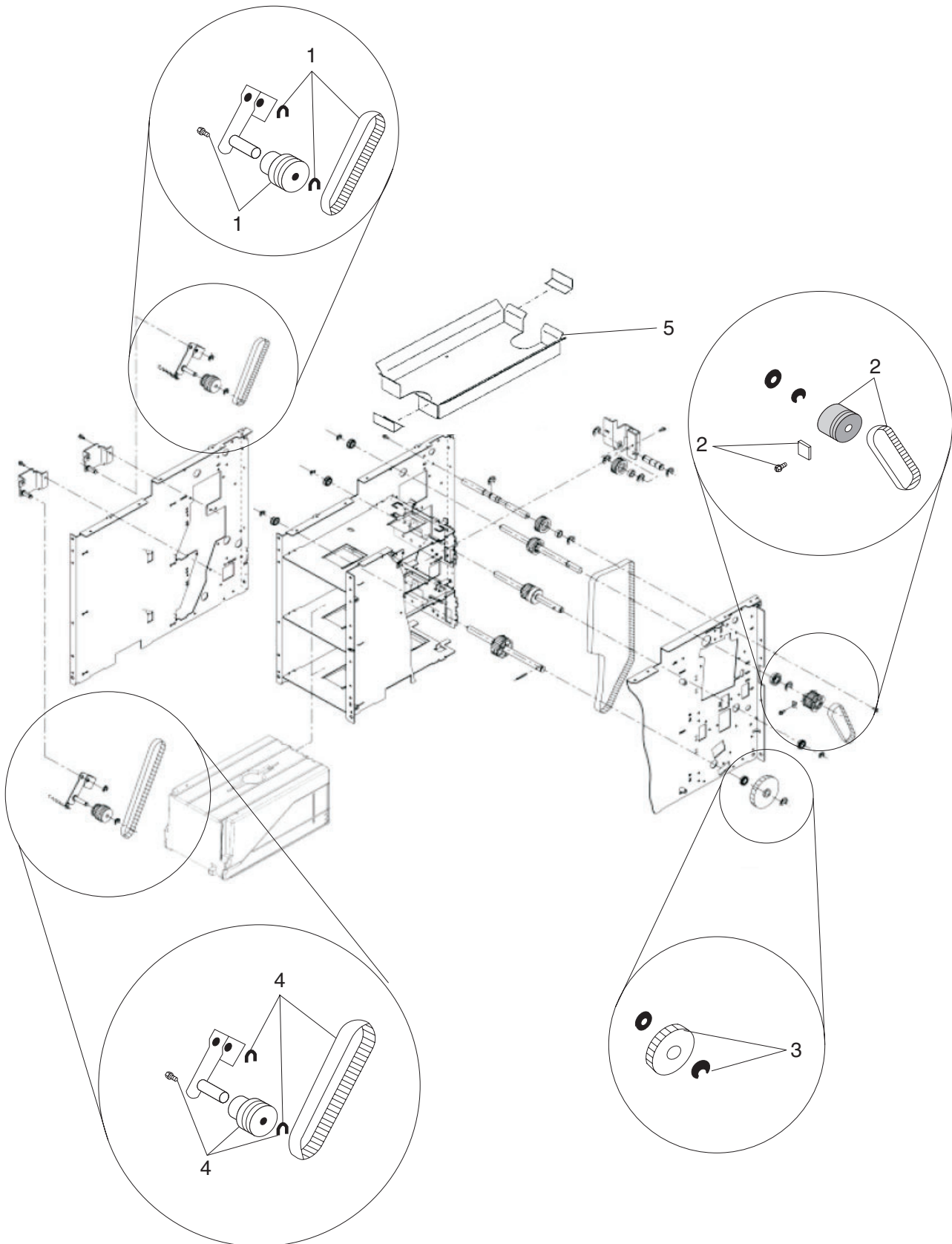

Asm- Index	Part Number	Units	Description
3-			See "How to Use This Parts Manual" on page v for general parts manual information, including ordering parts. See "Identifying a Right Hand or Left Hand Model" on page v for how to identify left hand and right hand models.
-1	41K6289	1	Timing kit, main unit channel 1 (includes 1 gear pulley, 2 retaining rings, 1 spring, 1 timing belt)
-2	41D7119	1	Timing kit, intermodule (includes 1 timing belt, 1 washer, 1 screw, 1 pulley)
-3	41K6303	1	Main/lower unit interconnect (includes 1 gear, 1 pin, 1 retainer E ring)
-4	41K6290	1	Timing kit, main unit channel 2 (includes 1 gear pulley, 2 retaining rings, 1 spring, 1 timing belt)
-5	41D7133	1	Reject bin

Assembly 4: Bill Dispenser Main Unit Illustration 2 of 3

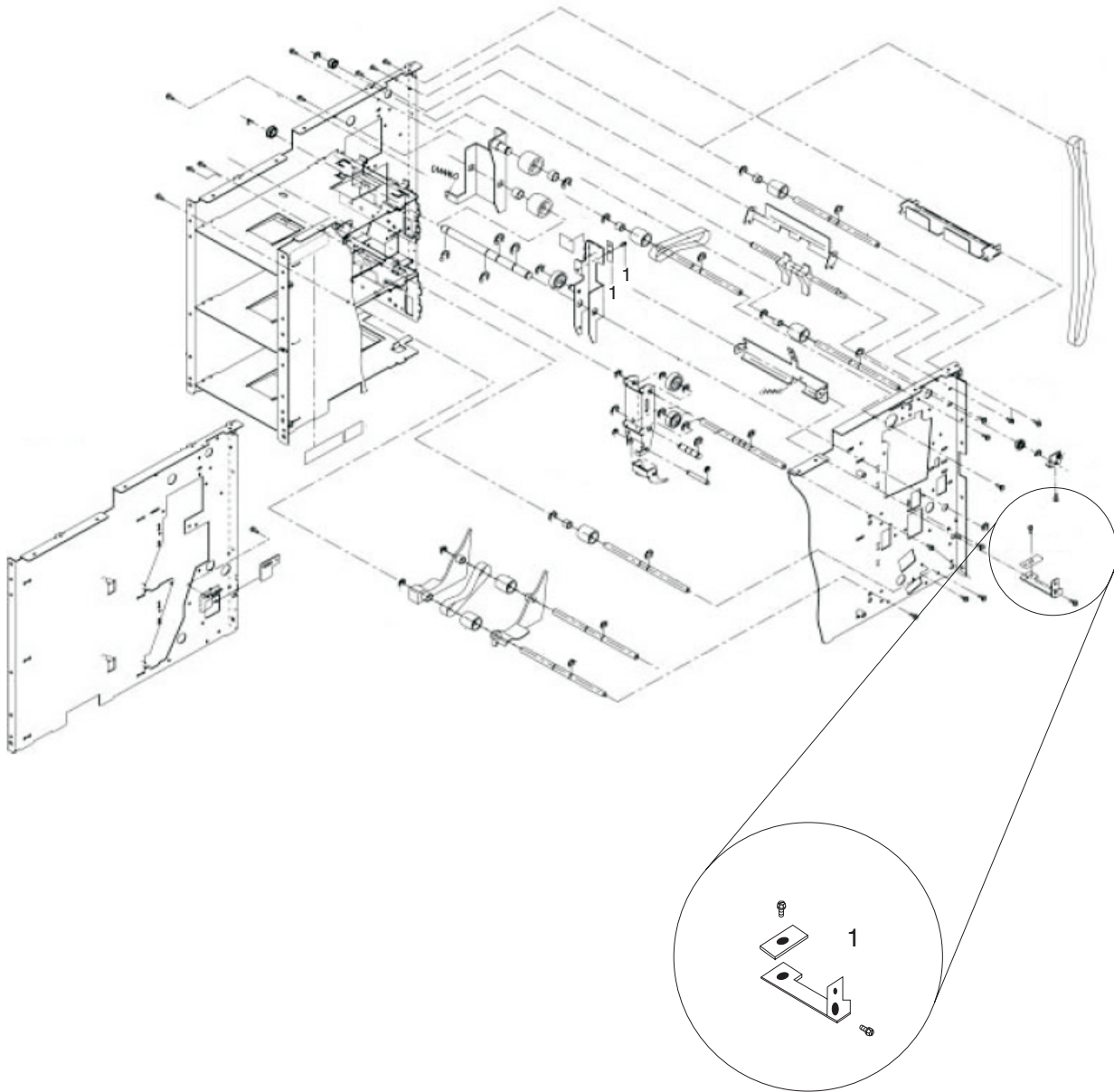

Asm- Index	Part Number	Units	Description
4-			See "How to Use This Parts Manual" on page v for general parts manual information, including ordering parts. See "Identifying a Right Hand or Left Hand Model" on page v for how to identify left hand and right hand models.
-1	41D7105	1	Scraper kit (includes 1 large and 1 small scraper, 2 screws (1 for each scraper))

Assembly 5: Bill Dispenser Main Unit Illustration 3 of 3

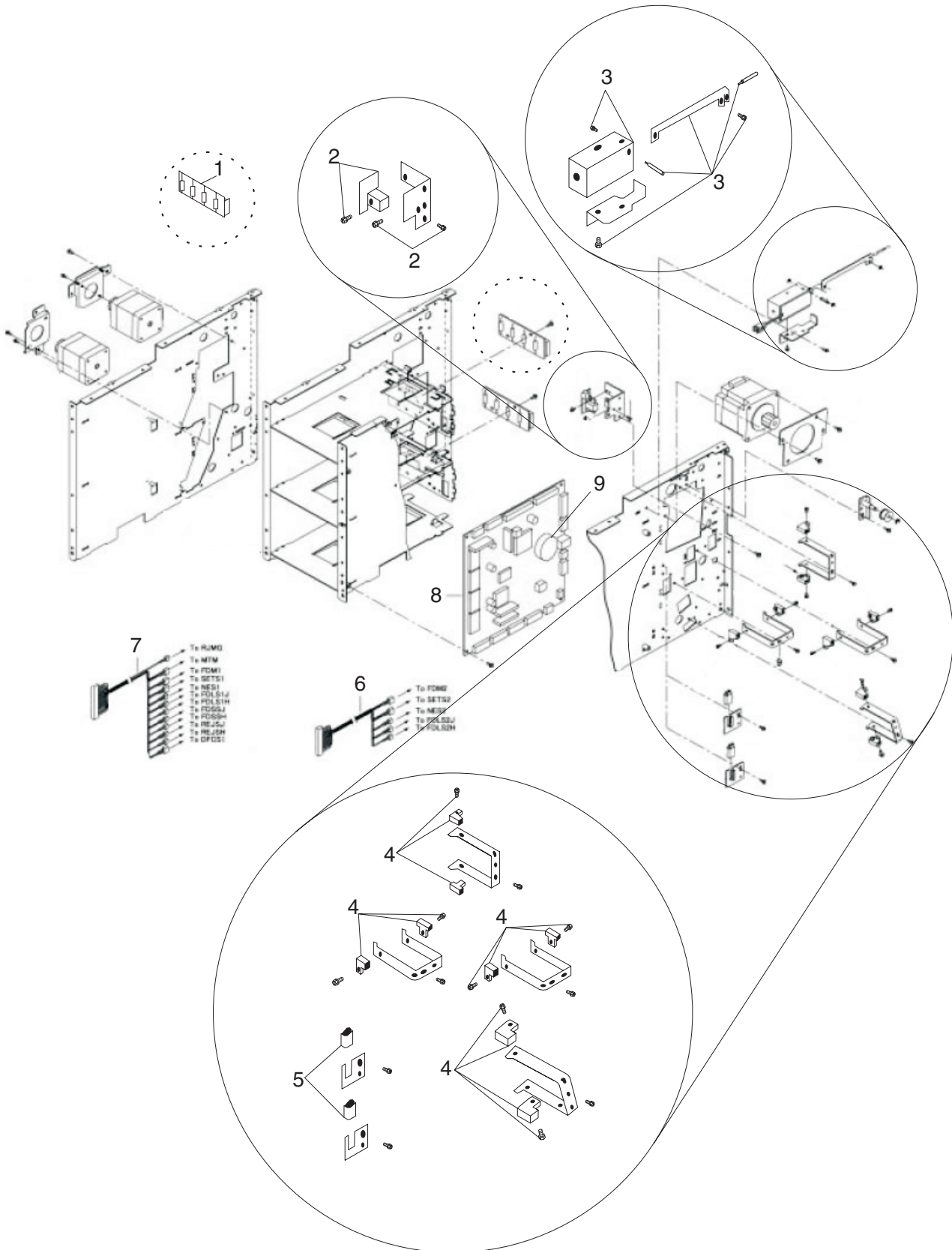

Asm- Index	Part Number	Units	Description
5-			See "How to Use This Parts Manual" on page v for general parts manual information, including ordering parts. See "Identifying a Right Hand or Left Hand Model" on page v for how to identify left hand and right hand models.
-1		1	Printed circuit board (reed switch type, sometimes referred to as a PCB) - not serviceable (replace the bill dispenser assembly)
-2	41D7103	1	Thickness sensor (includes 1 sensor, 2 screws, 1 shaft, 1 retaining ring)
-3	41D7107	1	Solenoid kit (includes 1 solenoid, 3 screws, 3 retaining rings, 1 spring, 1 shaft, 1 MG arm)
-4	41D7563	1	Bill dispenser sensor kit (includes 2 sensors, 2 screws)
-5	41D7125	1	Cassette sensor, bill dispenser
-6	41D7113	1	Cable, CAU 2 Main unit controlled access unit
-7	41D7111	1	Cable, CAU 1 Main unit
-8	41D7109	1	Printed circuit board (main unit, sometimes referred to as a PCB)
-9	04G5389	1	Battery, Lithium
-9	41D7610	1	Battery, Lithium bill dispenser (machines built after July 31, 2006)

Assembly 6: Bill Dispenser Lower Unit

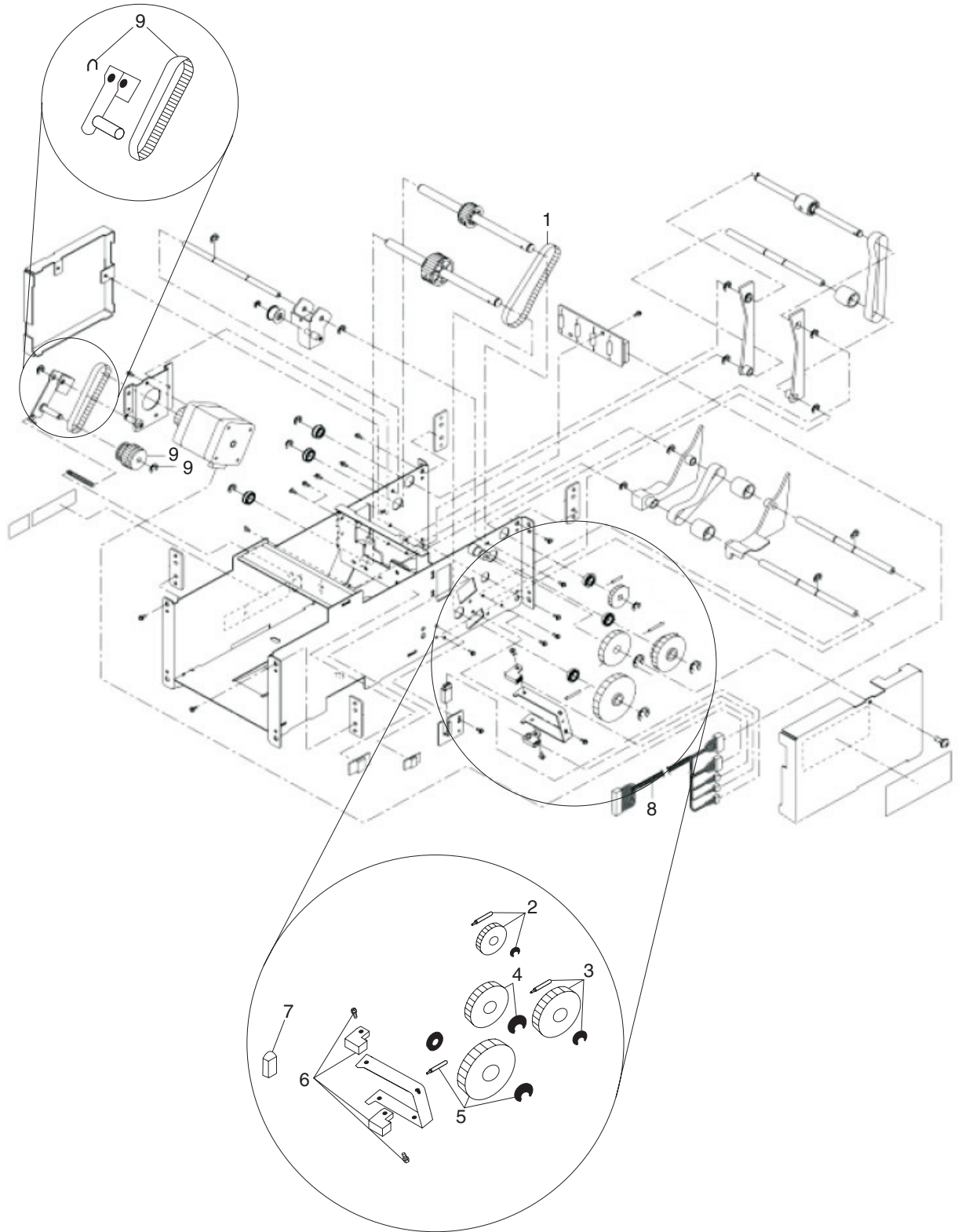

Asm- Index	Part Number	Units	Description
6-			See "How to Use This Parts Manual" on page v for general parts manual information, including ordering parts. See "Identifying a Right Hand or Left Hand Model" on page v for how to identify left hand and right hand models.
-1	41K6308	1	Lower unit timing belt
-2	41K6306	1	Lower unit gear 20 kit (includes 1 pin, 1 gear, 2 retaining E rings)
-3	41D7217	1	Lower unit gear 34 kit (includes 1 pin, 1 gear, 1 retaining E ring)
-4	41K6307	1	Lower unit gear 54 kit (includes 1 gear, 1 retaining ring)
-5	41D7121	1	Lower unit gear 44 kit (includes 1 pin, 1 gear, 1 retaining ring)
-6	41D7563	1	Bill dispenser sensor kit. See 5-4 on page 13.
-7	41D7125	1	Cassette sensor, bill dispenser
-8	41K6309	1	Cable assembly, lower unit
-9	41K6291	1	Timing kit, lower unit (includes 1 gear pulley, 2 retaining rings, 1 spring, 1 timing belt)

Assembly 7: Bill Dispenser Cassette

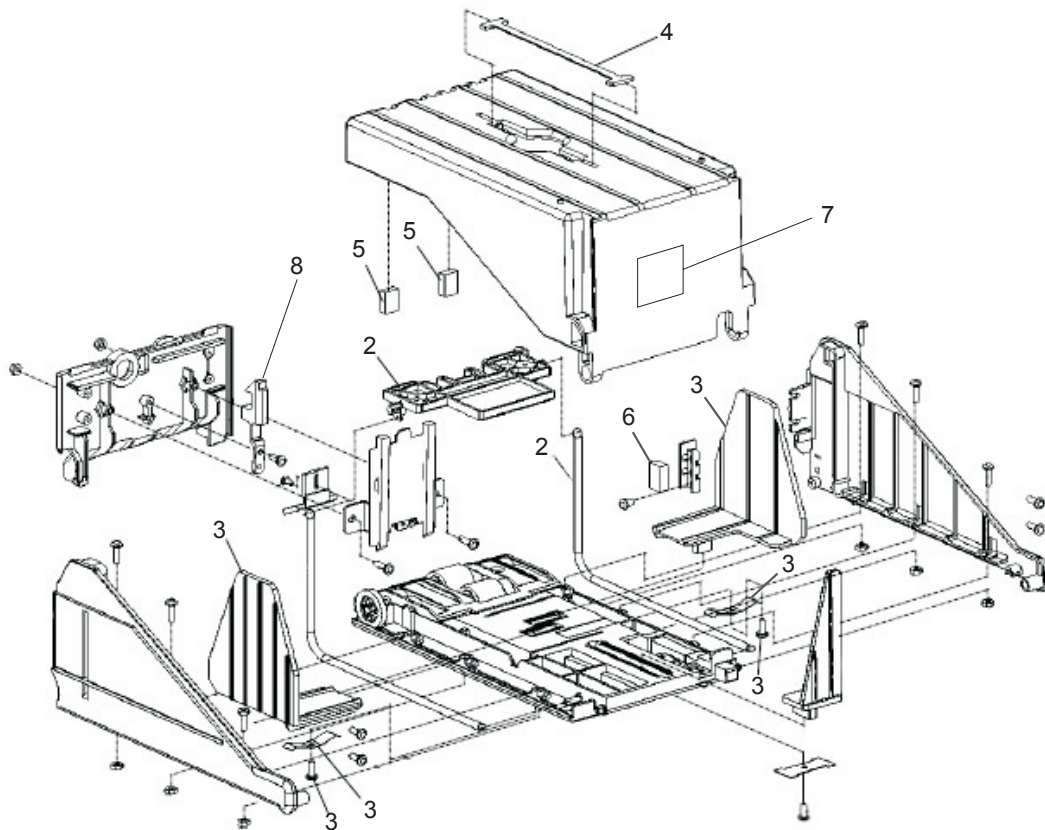
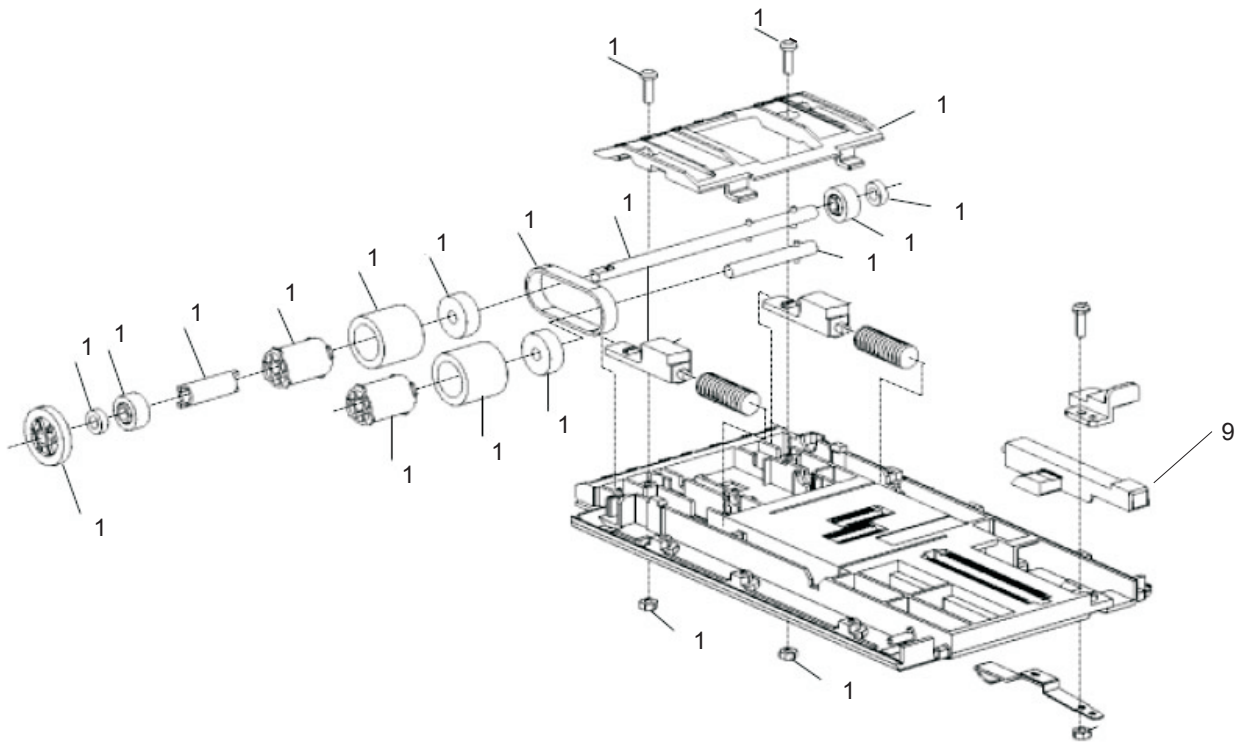

Asm- Index	Part Number	Units	Description
7-			See "How to Use This Parts Manual" on page v for general parts manual information, including ordering parts. See "Identifying a Right Hand or Left Hand Model" on page v for how to identify left hand and right hand models.
-	41D7053	1	Cassette, universal bill dispenser
-1	41D7115	1	Pick roller kit (includes 1 passway, 1 spacer, 2 shaft assemblies, 2 pulleys, 2 one-way rollers, 3 gears, 2 rollers, 2 bearings, 1 timing belt, 2 screws, 2 nuts)
-2	41K6298	1	Cassette pressure plate kit (includes 1 pressure plate, 1 spring, 1 rubber sheet)
-3	41D7117	1	Cassette currency rails kit (includes 2 adjuster S, 4 leaf springs, 1 adjuster R, 4 screws, 1 rear pressure, 1 spring, 1 rubber sheet)
-4	41K6300	1	Cassette handle
-5	41K6301	1	Cassette magnets (package of 2)
-6	41D7131	1	Cassette prism
-7	42K0061	1	Cassette label "1" (not shown)
-7	42K0062	1	Cassette label "5" (not shown)
-7	42K0063	1	Cassette label "10" (not shown)
-7	42K0064	1	Cassette label "20" (not shown)
-8	41K6322	1	Cassette latching hook
-9	44M1840	1	Cassette latch
-	41D7129	1	Low note sensor

Assembly 8: Bill Dispenser Communications and Power

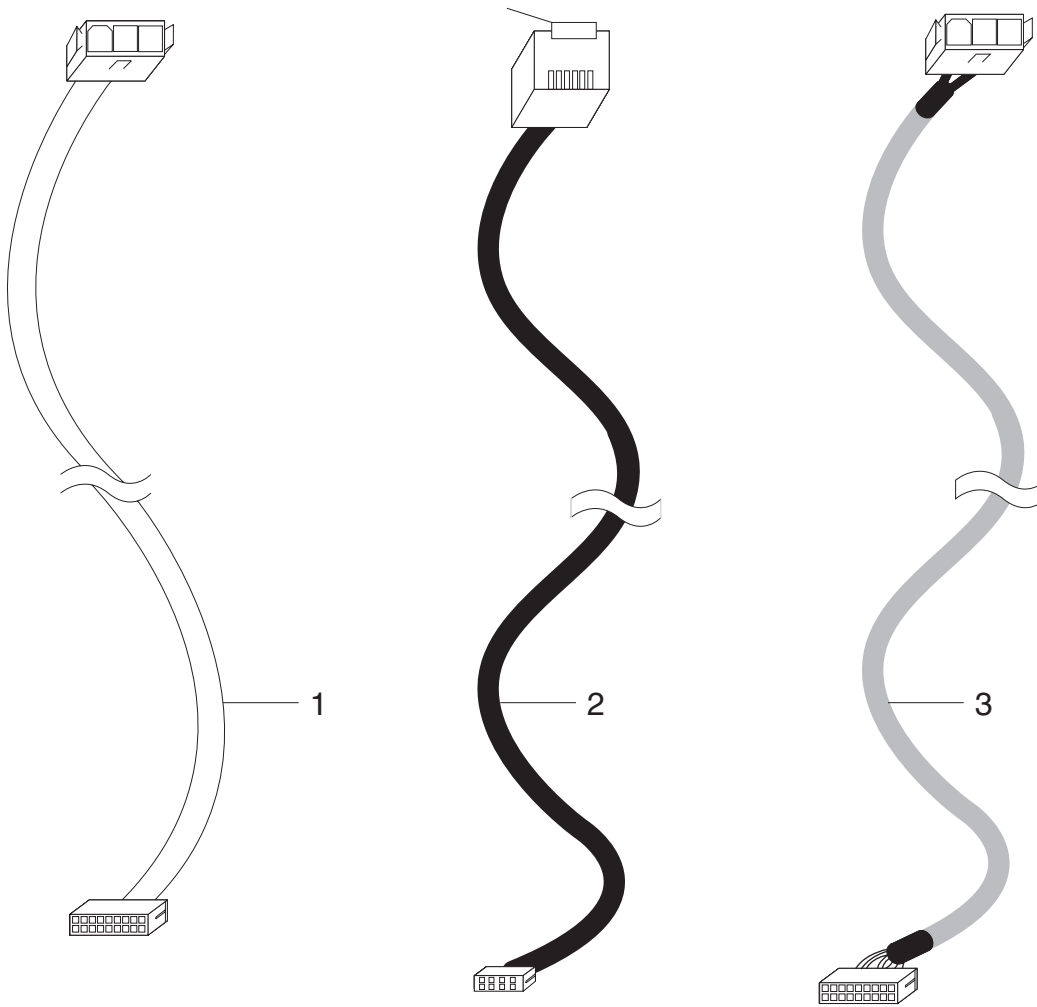

Asm- Index	Part Number	Units	Description
8-			See "How to Use This Parts Manual" on page v for general parts manual information, including ordering parts. See "Identifying a Right Hand or Left Hand Model" on page v for how to identify left hand and right hand models.
-1	39M5374	1	1.0m power jumper cord (Uninterruptible power supply to Controller Uninterruptible power supply In)
-2	40M9400	1	Cable, bill dispenser data
-3	41K6080	1	Power dongle, 24V
-	40N5606	1	Power adapter (power supply), 24V (not shown) (machines built after July 31, 2006)

Assembly 9: Coin Dispensers

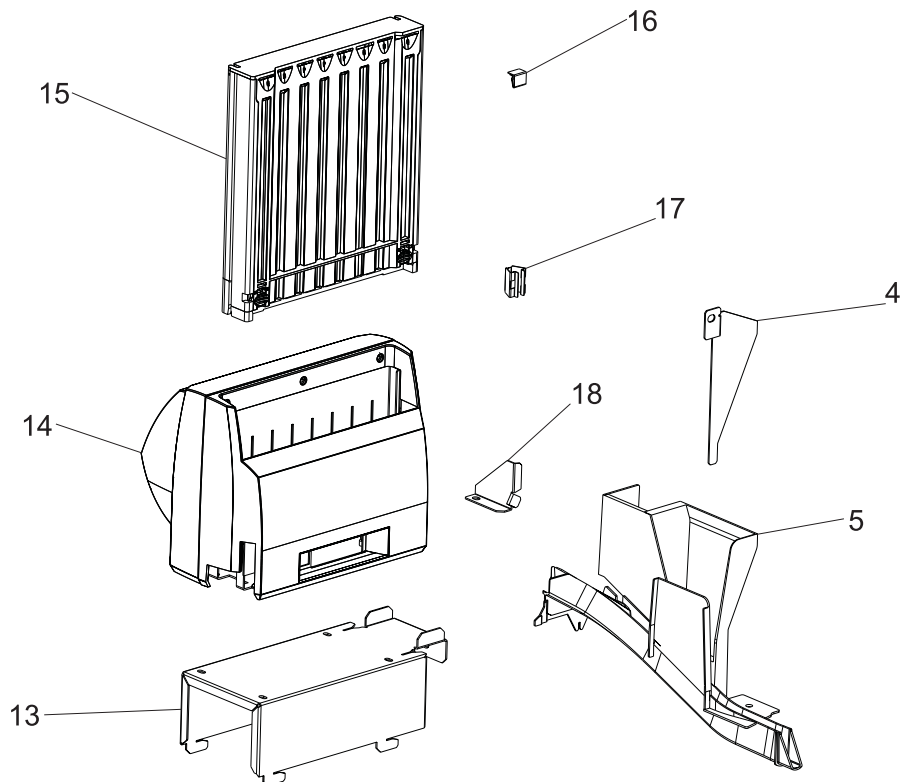
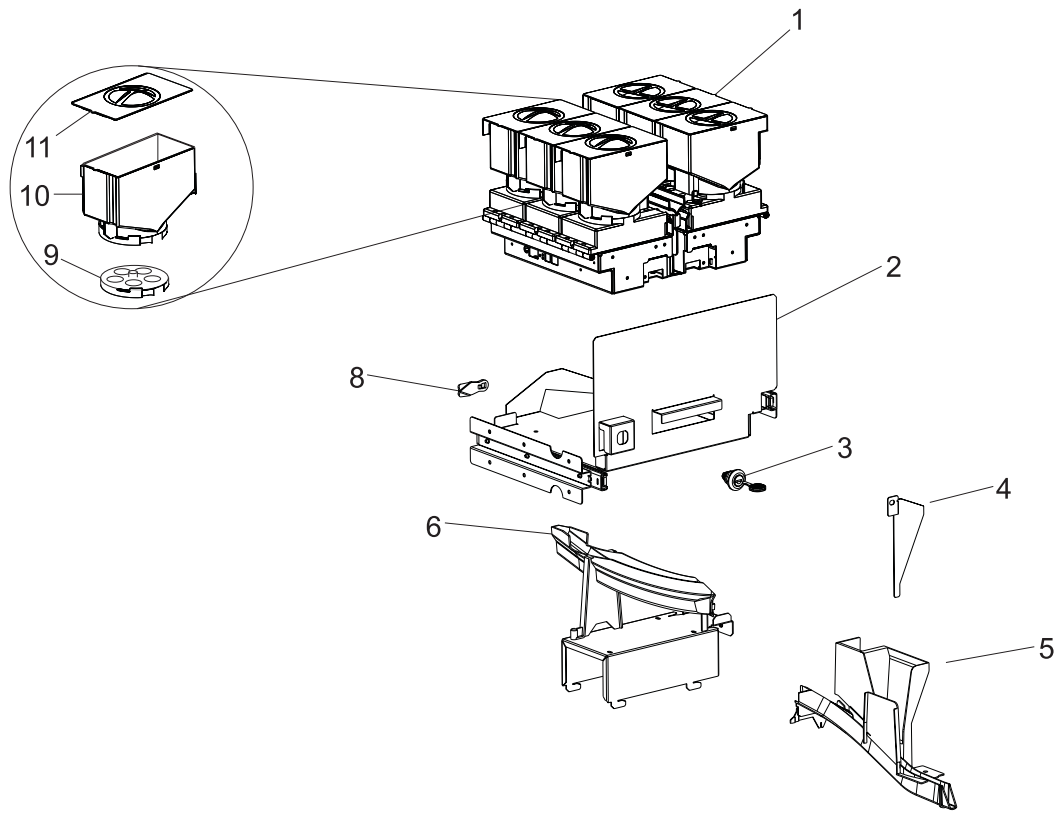

Asm- Index	Part Number	Units	Description
9-			See "How to Use This Parts Manual" on page v for general parts manual information, including ordering parts. See "Identifying a Right Hand or Left Hand Model" on page v for how to identify left hand and right hand models.
-	41D7047	1	Hopper coin dispenser, UK (includes assembly index # 1 ,9, 10, 11 and the base)
-	44D1294	1	Hopper coin dispenser, Euro (includes assembly index # 1 ,9, 10, 11 and the base)
-	41D7043	1	Hopper coin dispenser, US (includes assembly index # 1 ,9, 10, 11 and the base)
-	41D7045	1	Hopper coin dispenser, Canada (includes assembly index # 1 ,9, 10, 11 and the base)
-	41D7051	1	Hopper coin dispenser, Australia (includes assembly index # 1 ,9, 10, 11 and the base)
-1	41J7615	1	Hopper, coin dispenser, US/Canada .01
-1	41J7616	1	Hopper, coin dispenser, US/Canada .05
-1	41J7617	1	Hopper, coin dispenser, US/Canada .10
-1	41J7618	1	Hopper, coin dispenser, US/Canada .25
-1	41J7619	1	Hopper, coin dispenser, US/Canada 1.00
-1	41J7620	1	Hopper, coin dispenser, Canada 2.00
-1	41J7621	1	Hopper, coin dispenser, UK .01
-1	41J7622	1	Hopper, coin dispenser, UK .02
-1	41J7623	1	Hopper, coin dispenser, UK .05
-1	41J7624	1	Hopper, coin dispenser, UK .10
-1	41J7625	1	Hopper, coin dispenser, UK .20
-1	41J7626	1	Hopper, coin dispenser, UK 1.00
-1	41J7627	1	Hopper, coin dispenser, Euro .01
-1	41J7628	1	Hopper, coin dispenser, Euro .02
-1	41J7629	1	Hopper, coin dispenser, Euro .05
-1	41J7630	1	Hopper, coin dispenser, Euro .10
-1	41J7631	1	Hopper, coin dispenser, Euro .20
-1	41J7632	1	Hopper, coin dispenser, Euro .50
-1	41J7633	1	Hopper, coin dispenser, Euro 1.00
-1	41J7634	1	Hopper, coin dispenser, Euro 2.00
-2	41K6082	1	Hopper mount assembly, right hand (includes slide rails)
-2	41K6086	1	Hopper mount assembly, left hand (includes slide rails)
-3		1	Keylock. See Chapter 11, "Locks and Keys," on page 95.
-4	41D7076	1	Reject plate, coin, right hand
-4	41D7078	1	Reject plate, coin, left hand
-5	41K6363	1	Chute, coin, right hand, for both hopper and cassette coin dispensers
-5	41K6364	1	Chute, coin, left hand, for both hopper and cassette coin dispensers
-6	41D7813	1	Upper coin chute assembly, right hand
-6	41D7815	1	Upper coin chute assembly, left hand
-8	41K6088	1	Lock, cam
-9	41J7638	1	Hopper coin dispenser rotor, US/Canada .01
-9	41J7639	1	Hopper coin dispenser rotor, US/Canada .05
-9	41J7640	1	Hopper coin dispenser rotor, US/Canada .10
-9	41J7641	1	Hopper coin dispenser rotor, US .25, UK .10
-9	41J7642	1	Hopper coin dispenser rotor, US/Canada 1.00
-9	41J7643	1	Hopper coin dispenser rotor, Canada 2.00
-9	41J7644	1	Hopper coin dispenser rotor, UK .01
-9	41J7645	1	Hopper coin dispenser rotor, UK .02
-9	41J7646	1	Hopper coin dispenser rotor, UK .05
-9	41J7648	1	Hopper coin dispenser rotor, UK .20 Euro .05
-9	41J7649	1	Hopper coin dispenser rotor, UK 1.00
-9	44D1296	1	Hopper coin dispenser rotor, Euro .01
-9	41J7651	1	Hopper coin dispenser rotor, Euro .02/.10

Asm-Index	Part Number	Units	Description
-9	41J7654	1	Hopper coin dispenser rotor, Euro .20/1.00
-9	41J7655	1	Hopper coin dispenser rotor, Euro .50/2.00
-10	41J7658	1	Hopper coin dispenser bin, clear
-11	41J7659	1	Hopper coin dispenser bin cover kit (includes cover body, label set for US, UK, Euro)
-13	41K6353	1	Coin dispenser stand
-14	41K6077	1	Coin dispenser with cable and power supply (does not include cartridge/cassette) (unconfigured)
-14	41K7207	1	Coin dispenser with cable and power supply (does not include cartridge/cassette), US
-14	41K7208	1	Coin dispenser with cable and power supply (does not include cartridge/cassette), Canada
-14	41K7209	1	Coin dispenser with cable and power supply (does not include cartridge/cassette), Euro
-14	41K7210	1	Coin dispenser with cable and power supply (does not include cartridge/cassette), Australia
-14	41K7211	1	Coin dispenser with cable and power supply (does not include cartridge/cassette), UK
-15	28R3678	1	Cassette, coin, Canada
-15	28R3679	1	Cassette, coin, Euro
-15	28R3680	1	Cassette, coin, Australia
-15	28R5399	1	Cassette, coin, UK
-15	28R5466	1	Cassette, coin, US
-16	41D8231	1	Corner plug, coin dispenser (used to block loading of coins in one or more stacks)
-17	41D8229	1	Wing clip, coin dispenser cassette (used to block dispensing of coins from one or more stacks)
-18	41D8060	1	Coin cassette deflector, right hand
-18	41D8062	1	Coin cassette deflector, left hand
-	41D7403	1	Power supply, cassette coin dispenser, 32 VDC (not shown)
-	41D7404	1	Power supply, hopper coin dispenser, 24 VDC (not shown)
-	41K6352	1	Coin dispenser signal cable for both hopper and cassette dispensers (not shown)
-	39M5377	1	Power jumper cord, UK, EURO, Australia (not shown)
-	39M5081	1	Power jumper cord, US, Canada (not shown)
-	41J7635	1	Cable harness, position 1,2, and 3, hopper coin dispenser (not shown)
-	41J7636	1	Cable harness, position 4,5, and 6 hopper coin dispenser (not shown)
-	41J7637	1	Card assembly, hopper coin dispenser (not shown)

Updated October 16, 2007

Assembly 10: Coin Acceptor

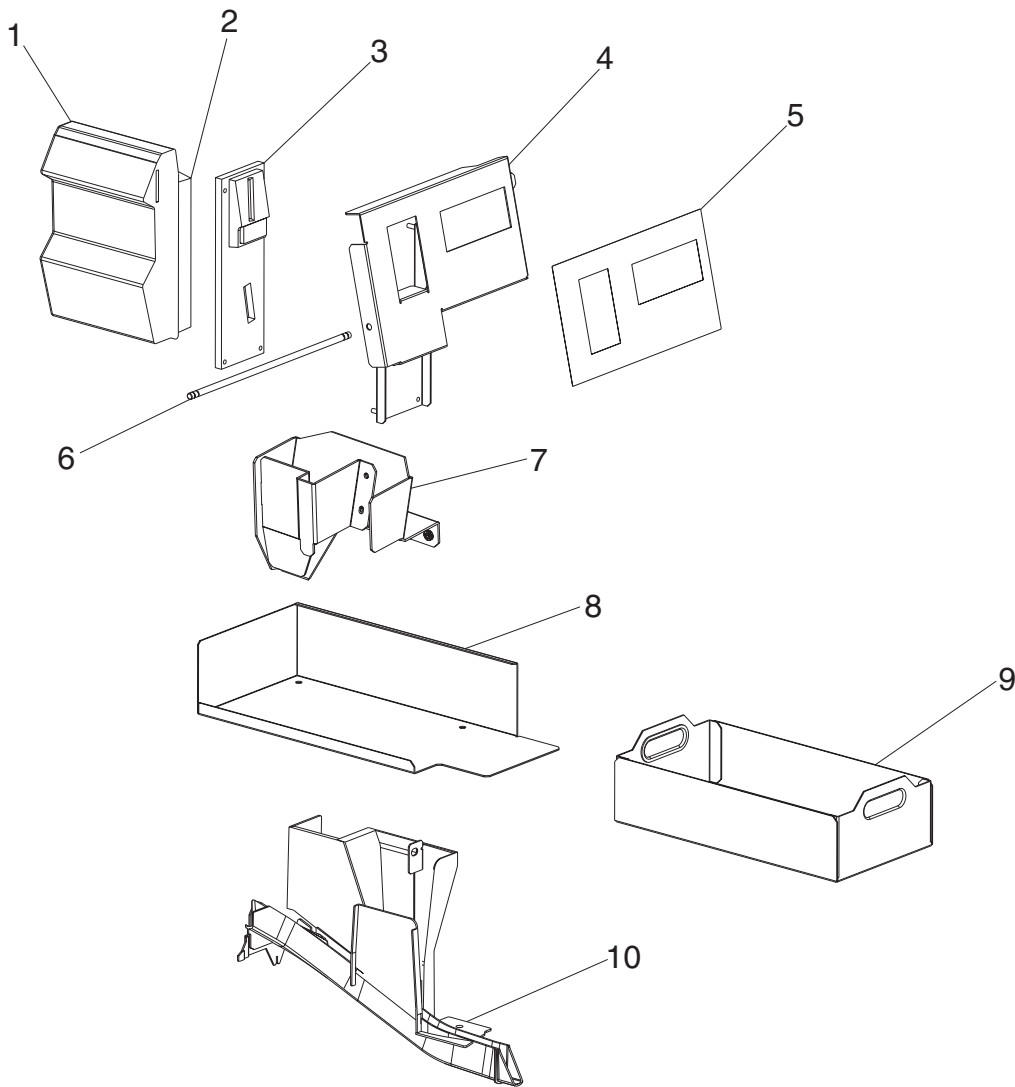

Asm- Index	Part Number	Units	Description
10-			See "How to Use This Parts Manual" on page v for general parts manual information, including ordering parts. See "Identifying a Right Hand or Left Hand Model" on page v for how to identify left hand and right hand models.
-1	41D9345	1	Coin Acceptor, MEI CF9520, US, with side reject plate (part 10-2) (machines built after July 31, 2006)
-1	41D8051	1	Coin Acceptor MEI, CF9520, US, rejects \$0.01, with side reject plate (part 10-2) (machines built after July 31, 2006)
-1	41J6735	1	Coin Acceptor MEI, CF9520, US, with side reject plate (part 10-2)
-1	41D9347	1	Coin Acceptor, MEI CF9520, UK, with side reject plate (part 10-2) (machines built after July 31, 2006)
-1	41J6736	1	Coin Acceptor MEI, CF9520, UK, with side reject plate (part 10-2)
-1	41D9346	1	Coin Acceptor, MEI CF9520, Canada, with side reject plate (part 10-2) (machines built after July 31, 2006)
-1	41J6737	1	Coin Acceptor, Canada, with side reject plate (part 10-2)
-1	41D9348	1	Coin Acceptor, MEI CF9520, Euro, with side reject plate (part 10-2) (machines built after July 31, 2006)
-1	41J6738	1	Coin Acceptor, Euro, with side reject plate (part 10-2)
-1	41D9349	1	Coin Acceptor, MEI CF9520, Australian, with side reject plate (part 10-2) (machines built after July 31, 2006)
-1	41J6739	1	Coin Acceptor, MEI CF9520, Australian, with side reject plate (part 10-2)
-2	41J8231	1	Coin acceptor side reject plate
-3	28R3292	1	Coin acceptor mounting plate
-4	42K0052	1	Cash acceptance bezel, right hand
-4	42K0053	1	Cash acceptance bezel, left hand
-5	42K0355	1	Label, cash in, right hand
-5	42K0359	1	Label, cash in, left hand
-6	41K6593	1	Shaft, cash acceptance bezel
-7	41J8076	1	Coin deflector, right hand
-7	42K0058	1	Coin deflector, left hand
-8	44D0245	1	Coin tray guide, right hand
-8	44D0246	1	Coin tray guide, left hand
-9	41K6160	1	Coin tray
-10	41K6363	1	Chute, coin RH
-10	41K6364	1	Chute, coin LH
-	28R5566	1	Ferrite core (installed on signal cable)
-	41K6354	1	Coin acceptor cable, US/Canada (not shown)
-	41K6359	1	Coin acceptor cable, EMEA/Australia (not shown)

Assembly 11: Bill Acceptor

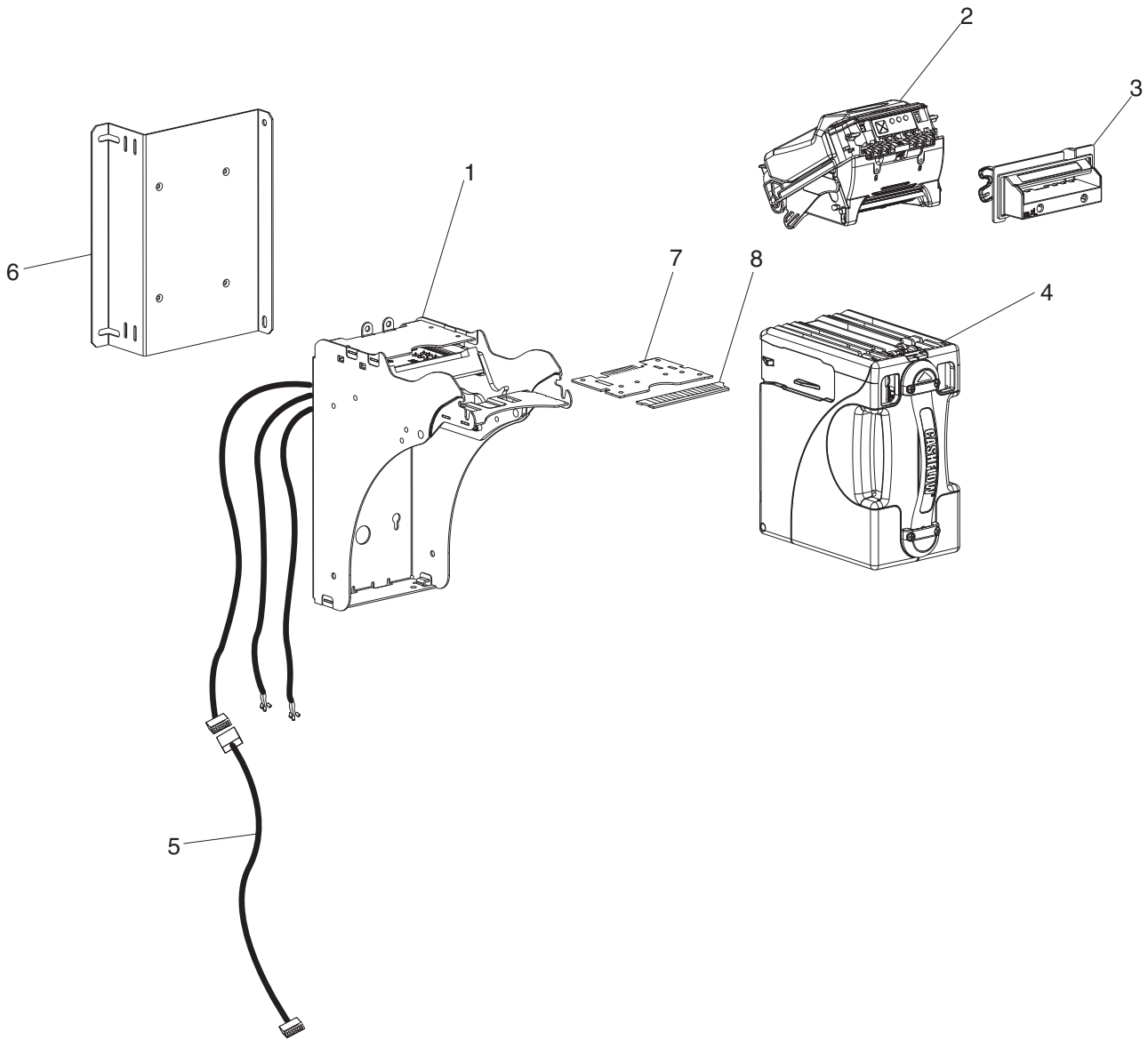

Asm- Index	Part Number	Units	Description
11-			See "How to Use This Parts Manual" on page v for general parts manual information, including ordering parts. See "Identifying a Right Hand or Left Hand Model" on page v for how to identify left hand and right hand models.
-	41J9330	1	Mars SC6607R bill acceptor, US
-	41D7250		Mars SC6607R bill acceptor, US (machines built after July 31, 2006)
-	40M9343	1	Mars SC6607R bill acceptor, Australian firmware
-	41D7254	1	Mars SC8307R bill acceptor, Euro, UK
-	41E1449	1	Mars SC8307R bill acceptor, Canadian firmware
-	40M9341	1	Mars SC8307R bill acceptor, UK firmware
-	40M9342	1	Mars SC8307R bill acceptor, Euro firmware
-1	44D0258	1	Chassis with connector cables, Mars SC bill acceptor (does not include 11-6 or 11-7)
-2	41D7249	1	Head, Mars SC6607R bill acceptor, US, Australia (replaces 41J9486)
-2	41D7252	1	Head, Mars SC8307R bill acceptor, UK, Euro, Canada
-2	41D9700	1	Head, Mars SC8307R bill acceptor, Canadian firmware
-2	41D9701	1	Head, Mars SC8307R bill acceptor, UK firmware
-2	41D9702	1	Head, Mars SC8307R bill acceptor, Euro firmware
-2	41D9703	1	Head, Mars SC6607R bill acceptor, Australian firmware
-3	41D7251	1	Universal bezel with gap filler, Mars SC6607R bill acceptor, US, Australia (replaces 28R3477)
-3	41D7253	1	Universal bezel with gap filler, Mars SC8307R bill acceptor, UK, Euro, Canada (replaces 28R5028)
-4	41D7248	1	Cash Box, Mars SC bill acceptors (replaces 28R3492)
-5	28R3684	1	Mars SC bill acceptor data cable
-6	41K6109	1	Bill acceptor mounting bracket
-7	44D0260	1	Interface card, MEI SC series bill acceptor
-8	44D0262	1	Edge connector, MEI SC series bill acceptor

Assembly 12: Printers Tlx and TGx

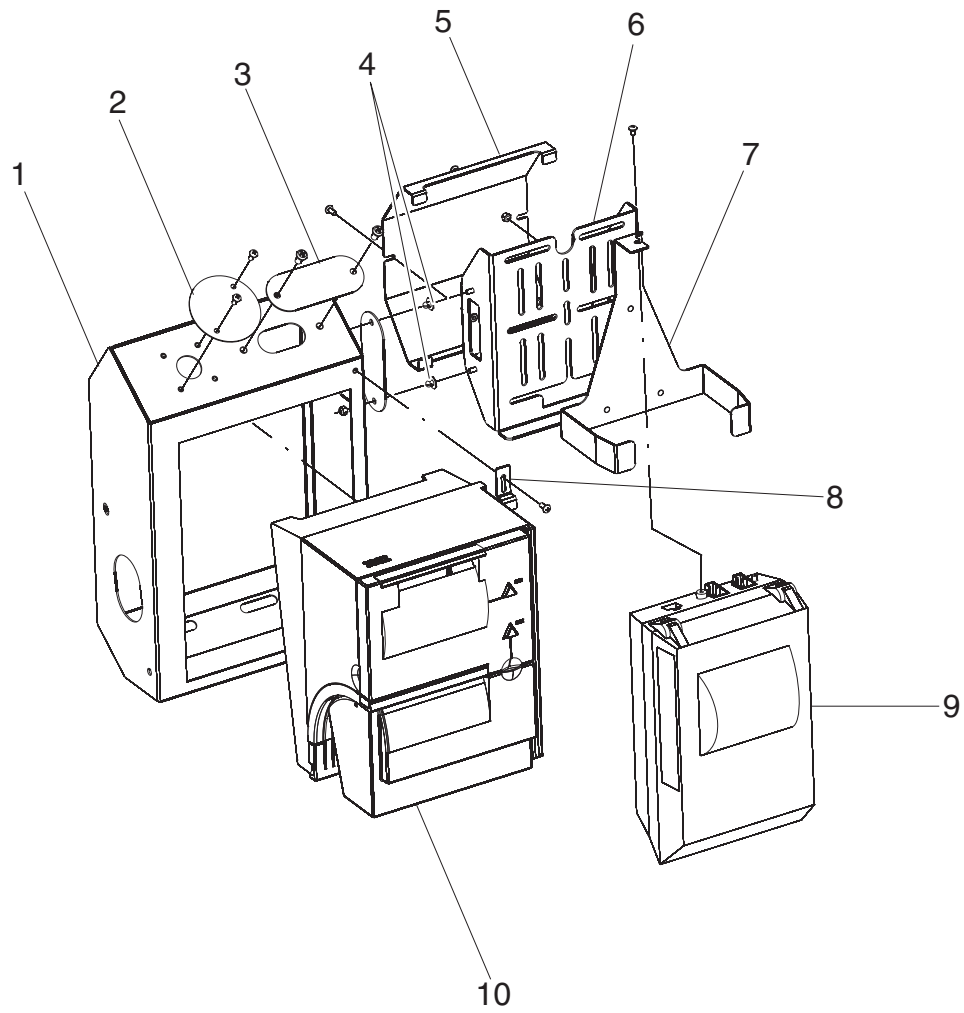

Asm- Index	Part Number	Units	Description
12-			Printer, left hand iron gray
-1	41J9442	1	Printer shelf, TI and TG, left hand, iron gray
-2	41J9770	1	Hole cover, round, iron gray
-3	41J9457	1	Hole cover, oval, iron gray
-4	41J8809	1	Rivet, black push in
-5	41J9447	1	Printer, Catalina, back cover, iron gray
-6	41J9438	1	Printer, Catalina, left hand auxiliary mounting bracket iron gray (used with 41J9442)
-7	41J9452	1	Printer, Catalina, mounting bracket, iron gray (used with 41J9438)
-8	41J9416	1	Locking bracket, iron gray
-9		1	Catalina Printer (customer furnished)
-10		1	TI/TG Printer. See <i>IBM 4610 SureMark Printers Hardware Service Manual, GY27-0355.</i>
-	41D9648	1	Printer, Catalina, support bracket, left hand, iron gray
-			Printer, left hand pearl white
-1	41J9444	1	Printer shelf, TI and TG, left hand, pearl white
-2	41J9772	1	Hole cover, round, pearl white
-3	41J9459	1	Hole cover, oval, pearl white
-4	41J8807	1	Rivet, off white push in
-5	41J9449	1	Printer, Catalina, back cover, pearl white
-6	41J9440	1	Printer, Catalina, left hand auxiliary mounting bracket pearl white (used with 41J9444)
-7	41J9454	1	Printer, Catalina, mounting bracket pearl white (used with 41J9440)
-8	41J9418	1	Locking bracket, pearl white
-9		1	Catalina Printer (customer furnished)
-10		1	TI/TG Printer. See <i>IBM 4610 SureMark Printers Hardware Service Manual, GY27-0355.</i>
-	41D9650	1	Printer, Catalina, support bracket, left hand, pearl white
-			Printer, right hand iron gray
-1	41J9465	1	Printer shelf, TI and TG, right hand, iron gray
-2	41J9770	1	Hole cover, round, iron gray
-3	41J9457	1	Hole cover, oval, iron gray
-4	41J8809	1	Rivet, black push in
-5	41J9447	1	Printer, Catalina, back cover, iron gray
-6	41J9461	1	Printer, Catalina, right hand auxiliary mounting bracket iron gray (used with 41J9465)
-7	41J9452	1	Printer, Catalina, mounting bracket, iron gray (used with 41J9461)
-8	41J9416	1	Locking bracket, iron gray
-9		1	Catalina Printer (customer furnished)
-10		1	TI/TG Printer. See <i>IBM 4610 SureMark Printers Hardware Service Manual, GY27-0355.</i>
-	41D9642	1	Printer, Catalina, support bracket, right hand, iron gray
-			Printer, right hand pearl white
-1	41J9467	1	Printer shelf, TI and TG, right hand, pearl white
-2	41J9772	1	Hole cover, round, pearl white
-3	41J9459	1	Hole cover, oval, pearl white
-4	41J8807	1	Rivet, off white push in
-5	41J9449	1	Printer, Catalina, back cover, pearl white
-6	41J9463	1	Printer, Catalina, right hand auxiliary mounting bracket pearl white (used with 41J9467)
-7	41J9454	1	Printer, Catalina, mounting bracket pearl white (used with 41J9467)

Asm- Index	Part Number	Units	Description
-8	41J9418	1	Locking bracket, pearl white
-9		1	Catalina Printer (customer furnished)
-10		1	TI/TG Printer. See <i>IBM 4610 SureMark Printers Hardware Service Manual, GY27-0355</i> .
-	41D9644	1	Printer, Catalina, support bracket, right hand, pearl white

Updated October 16, 2007

Assembly 13: Printers TF6 and TM6

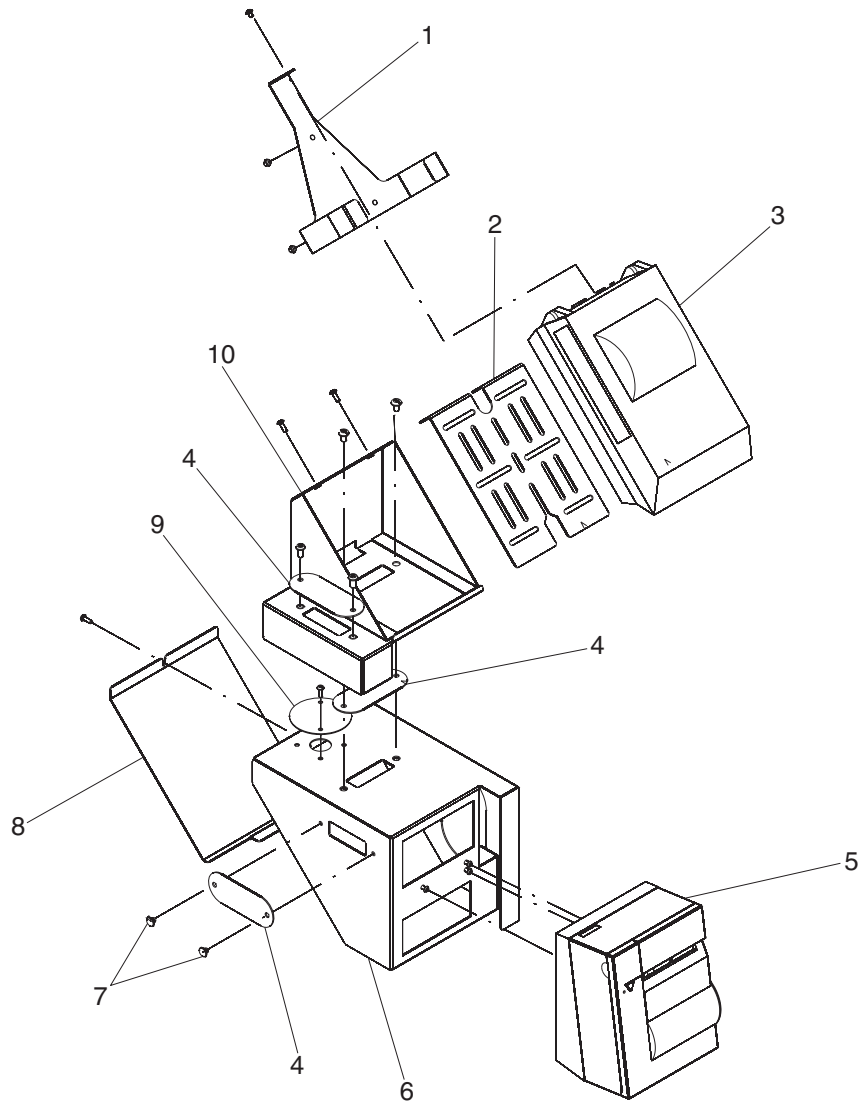

Asm- Index	Part Number	Units	Description
13-			Printer, right hand iron gray
-1	41J9452	1	Bracket, mounting Catalina printer, iron gray
-2	41J9533	1	Mounting bracket Catalina printer, right hand, iron gray (used with 41J9523)
-3		1	Catalina printer (customer furnished)
-4	41J9457	1	Hole cover, oval, iron gray
-5		1	Printer, TF6 and TM6. See <i>IBM 4610 SureMark Printers Hardware Service Manual, GY27-0355</i> .
-6	41J9513	1	Printer shelf, 4610-TF6/TM6, right hand, iron gray
-7	41J8809	1	Rivet, black push in
-8	41J9538	1	Back cover, Catalina printer, iron gray (used with 41J9513)
-9	41J9770	1	Hole cover, round, iron gray
-10	41J9523	1	Auxiliary mount bracket Catalina printer, right hand, iron gray (used with 41J9513)
-	41D9653	1	Support bracket Catalina printer, iron gray
-			Printer, right hand pearl white
-1	41J9454	1	Bracket, mounting Catalina printer, pearl white
-2	41J9535	1	Mounting bracket Catalina printer, right hand, pearl white (used with 41J9525)
-3		1	Catalina printer (customer furnished)
-4	41J9459	1	Hole cover, oval, pearl white
-5		1	Printer, TF6 and TM6. See <i>IBM 4610 SureMark Printers Hardware Service Manual, GY27-0355</i> .
-6	41J9515	1	Printer shelf, 4610-TF6/TM6, right hand pearl white
-7	41J8807	1	Rivet, off white push in
-8	41J9540	1	Back cover, Catalina printer, pearl white (used with 41J9515)
-9	41J9772	1	Hole cover, round, pearl white
-10	41J9525	1	Auxiliary mount bracket Catalina printer, right hand, pearl white (used with 41J9515)
-	41D9655	1	Support bracket, Catalina printer, pearl white
-			Printer, left hand iron gray
-1	41J9452	1	Bracket, mounting Catalina printer, iron gray
-2	41J9533	1	Mounting bracket Catalina printer, left hand, iron gray (used with 41J9528)
-3		1	Catalina printer (customer furnished)
-4	41J9457	1	Hole cover, oval, iron gray
-5		1	Printer, TF6 and TM6. See <i>IBM 4610 SureMark Printers Hardware Service Manual, GY27-0355</i> .
-6	41J9518	1	Printer shelf, 4610-TF6/TM6, left hand iron gray
-7	41J8809	1	Rivet, black push in
-8	41J9538	1	Back cover, Catalina printer, iron gray (used with 41J9518)
-9	41J9770	1	Hole cover, round, iron gray
-10	41J9528	1	Auxiliary mount bracket Catalina printer, left hand, iron gray (used with 41J9518)
-	41D9653	1	Support bracket Catalina printer, iron gray
-			Printer, left hand pearl white
-1	41J9454	1	Bracket, mounting Catalina printer, pearl white
-2	41J9535	1	Mounting bracket Catalina printer, left hand, pearl white (used with 41J9530)
-3		1	Catalina printer (customer furnished)
-4	41J9459	1	Hole cover, oval, pearl white
-5		1	Printers, TF6 and TM6. See <i>IBM 4610 SureMark Printers Hardware Service Manual, GY27-0355</i> .
-6	41J9520	1	Printer shelf, 4610-TF6/TM6, left hand pearl white
-7	41J8807	1	Rivet, off white push in
-8	41J9540	1	Back cover, Catalina printer, pearl white (used with 41J9520)
-9	41J9772	1	Hole cover, round, pearl white

Asm- Index	Part Number	Units	Description
-10	41J9530	1	Auxiliary mount bracket Catalina printer, left hand, pearl white (used with 41J9520)
-	41D9655	1	Support bracket, Catalina printer, pearl white

Updated October 16, 2007

Assembly 14: Printers Fiscal

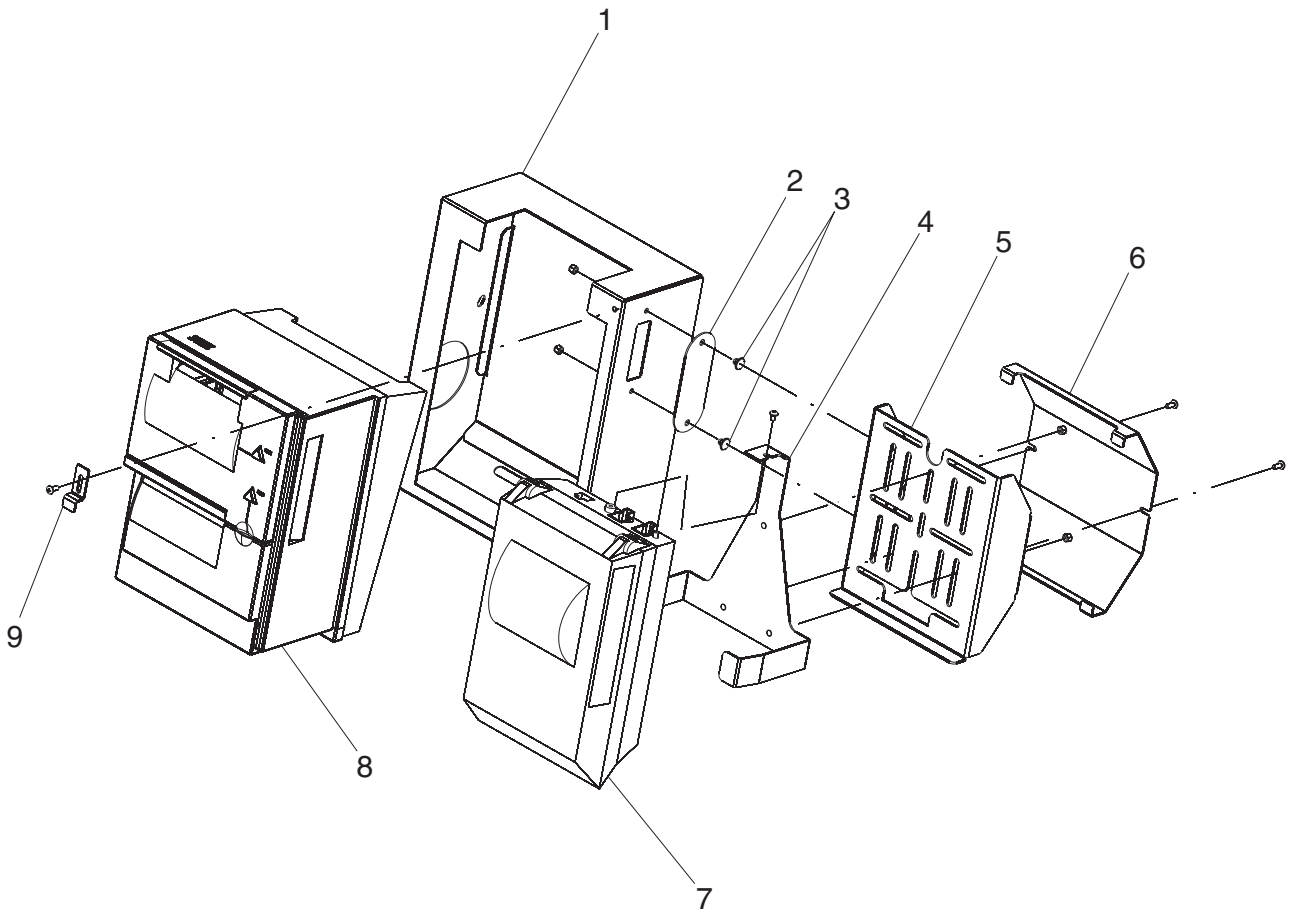

Asm-Index	Part Number	Units	Description
14-			Printer, right hand pearl white
I -1	41J9666	1	Printer shelf, Fiscal, right hand pearl white (Models 152, 602, and 612)
-2	41J9459	1	Hole cover, oval, pearl white
-3	41J8807	1	Rivet, off white push in nylon
-4	41J9454	1	Bracket, mounting Catalina printer, pearl white (used with 41J9463)
-5	41J9463	1	Auxiliary mount bracket Catalina printer, right hand, pearl white (used with 41J9666)
-6	41J9449	1	Printer, Catalina, back cover, pearl white
-7		1	Catalina printer (customer furnished)
-8		1	Fiscal printer. See <i>IBM 4610 SureMark Printers Hardware Service Manual, GY27-0355</i> .
-9	41J9418	1	Locking bracket, pearl white
-			Printer, left hand pearl white
I -1	41J9670	1	Printer shelf, Fiscal, left hand pearl white (Models 152, 602, and 612)
-2	41J9459	1	Hole cover, oval, pearl white
-3	41J8807	1	Rivet, off white push in nylon
-4	41J9454	1	Bracket, mounting Catalina printer, pearl white (used with 41J9440)
-5	41J9440	1	Auxiliary mount bracket Catalina printer, left hand, pearl white (used with 41J9670)
-6	41J9449	1	Printer, Catalina, back cover, pearl white
-7		1	Catalina printer (customer furnished)
-8		1	Fiscal printer. See <i>IBM 4610 SureMark Printers Hardware Service Manual, GY27-0355</i> .
-9	41J9418	1	Locking bracket, pearl white

Assembly 15: Printers Epson

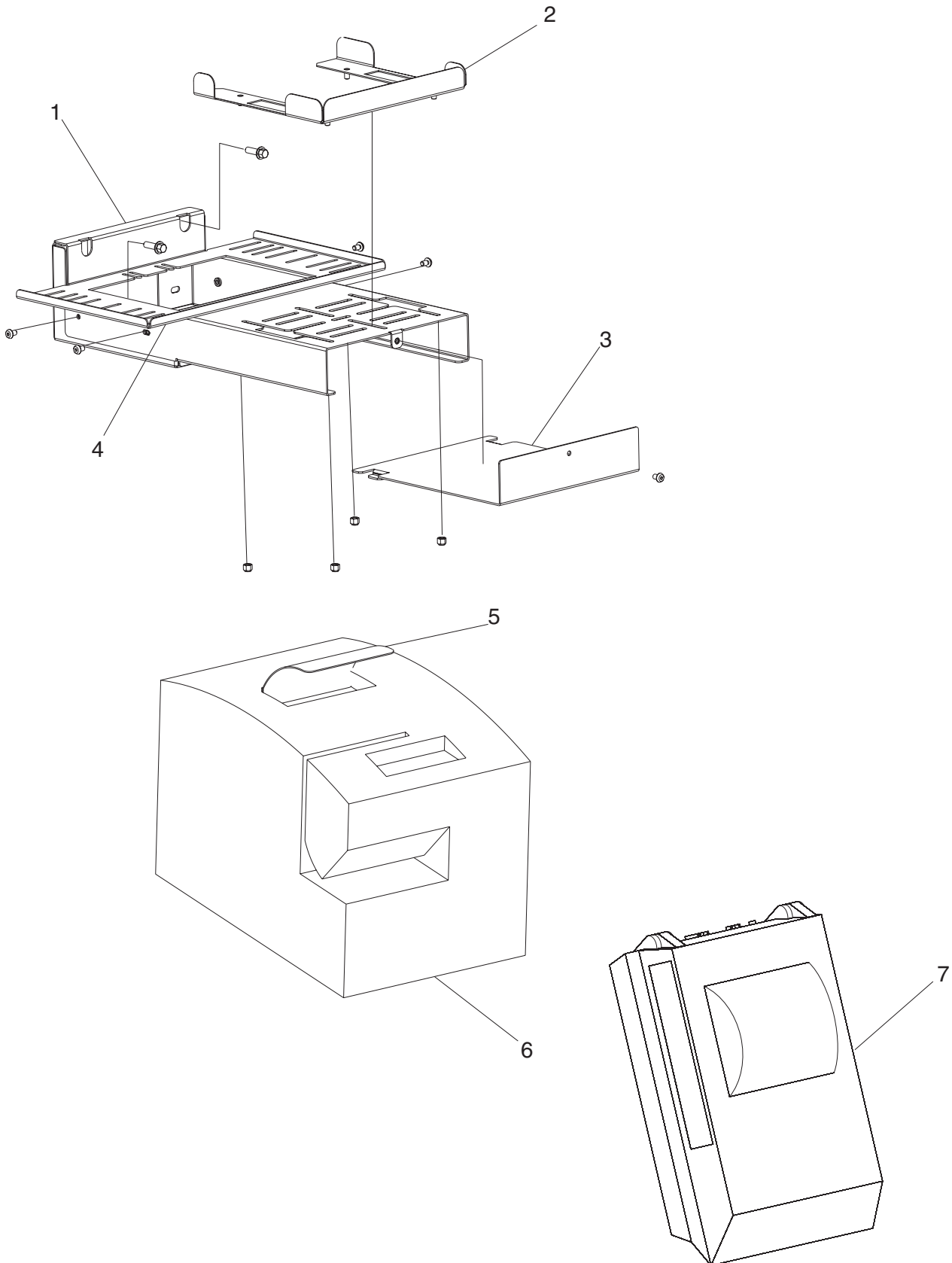

Asm- Index	Part Number	Units	Description
15-			Printer, iron gray
-1	44D0252	1	Printer support bracket, iron gray
-2	44D0361	1	Support bracket for Catalina printer, iron gray
-3	44D0256	1	Cable cover for Catalina printer, iron gray
-4	44D0254	1	Auxiliary support bracket Catalina printer, iron gray
-5	44D0381	1	Paper diverter, Epson printer
-	44D0922	1	Mount adapter plate, Epson printer, iron gray
-6		1	Epson printer (customer furnished)
-7		1	Catalina printer (customer furnished)
-			Printer, pearl white
-1	41D8573	1	Printer support bracket, pearl white
-2	44D0359	1	Support bracket for Catalina printer, pearl white
-3	41D8579	1	Cable cover for Catalina printer, pearl white
-4	41D8576	1	Auxiliary support bracket Catalina printer, pearl white
-5	44D0381	1	Paper diverter, Epson printer
-	44D0920	1	Mount adapter plate, Epson printer, pearl white
-6		1	Epson printer (customer furnished)
-7		1	Catalina printer (customer furnished)

Assembly 16: Magnetic stripe reader and pin pad mount

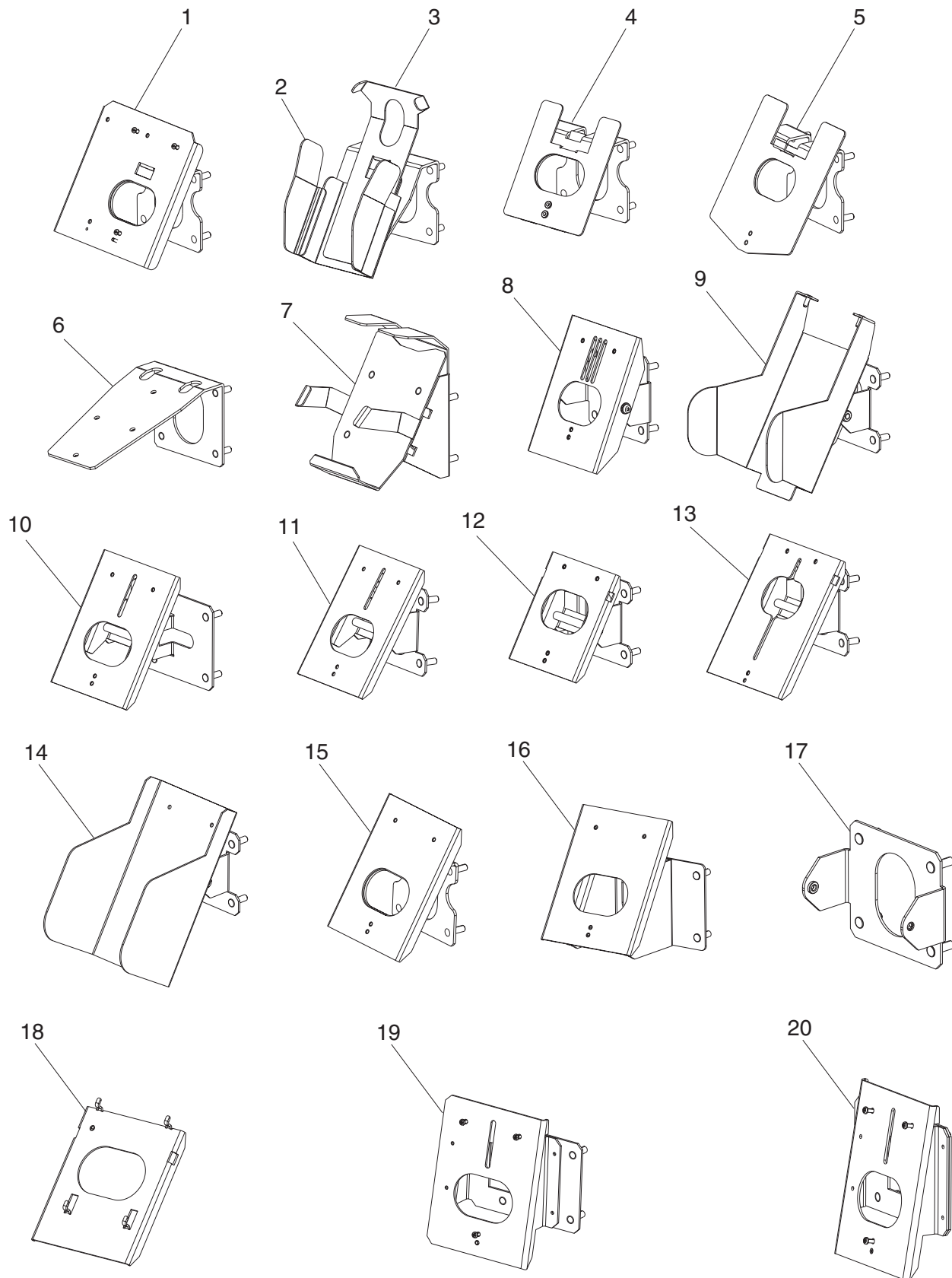

Asm-Index	Part Number	Units	Description
16-1	41J8883	1	Magnetic stripe reader bracket, Verifone Omni 7000
-2	41J9662	1	Magnetic stripe reader shield, Ingenico 3500
-3	41J9660	1	Magnetic stripe reader bracket, Ingenico 3500
-4	41D7155	1	Bracket, Ingenico 6550 pin pad mounting
-5	41D7156	1	Bracket, Ingenico 6770 pin pad mounting
-6	41J7193	1	Magnetic stripe reader bracket, Banksys C-Zam Smash
-7	41D7246	1	Magnetic stripe reader bracket, Ingenico 3300
-8	41D7586	1	Mount, Checkmate 2001 pin pad
-9	41D7680	1	Mount, Wymix pin pad
-10	41D8391	1	Mount, Verifone OMNI 7000 pin pad (left hand)
-11	41D7767	1	Mount, Verifone OMNI 490 Hypercom L4100 Verifone TT8800
-12	41J9157	1	Magnetic stripe reader mount bracket w/tilt assembly, Ingenico 6550
-13	41J9154	1	Magnetic stripe reader mount bracket assembly, Ingenico Entouch 1000
-14	41D8143	1	Magnetic stripe reader mounting bracket assembly Moneyline L3000
-	41J9765	1	Magnetic stripe reader washer, Ingenico 3500 (not shown) (Models 152, 602, and 612)
-15	41D7142	1	Mounting bracket, Verifone Everest Plus (right hand)
-16	41D7144	1	Mounting bracket, Verifone Everest Plus (left hand)
-17	41D7061	1	Support bracket, Verifone MX870 pin pad
-18	41D7634	1	Support bracket, Hypercom 5500
-19	41D9876	1	Mount, Verifone Omni 7000MPD pin pad (right hand)
-20	44D0347	1	Mount, Verifone Omni 7000MPD pin pad (left hand)
-	41D7595	1	Cable cover, Verifone and Checkmate mount (not shown)
-	41D7588	1	Mount bracket Checkmate 2001 pin pad (not shown)
-	41D7169	1	Bracket, locking for Wymix pin pad (not shown)

Assembly 17: Hand held scanner

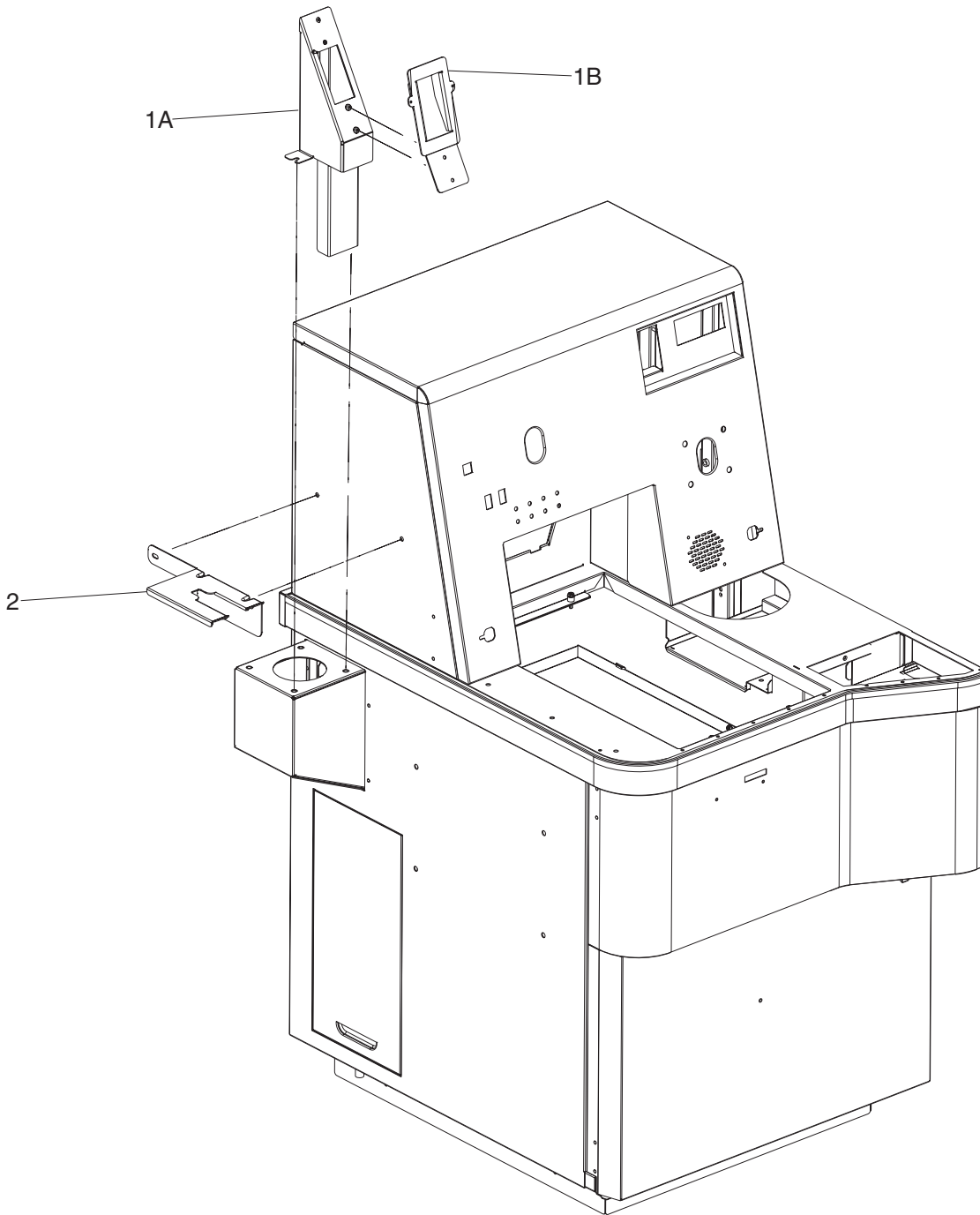

Asm- Index	Part Number	Units	Description
17-	41D7242	1	Bracket for hand held scanner, pearl white (mounts to lane light bustle - Models 153, 603, and 613 only)
-	41D9435	1	Bracket for hand held scanner, iron gray (mounts to lane light bustle - Models 153, 603, and 613 only)
-1A	44D0241	1	Bracket, hand held scanner
-1B	44D0243	1	Bracket, hand held scanner
-2	41J9812	1	Bracket, hand held scanner, right hand, silver
-2	41J9817	1	Bracket, hand held scanner, left hand, silver
-2	41D8445	1	Bracket, hand held scanner, right hand, Formica white
-2	41D8448	1	Bracket, hand held scanner, left hand, Formica white
-2	41D1011	1	Bracket, hand held scanner, right hand, iron gray
-2	41D1015	1	Bracket, hand held scanner, left hand, iron gray
-2	41D1013	1	Bracket, hand held scanner, right hand, pearl white
-2	41D1017	1	Bracket, hand held scanner, left hand, pearl white
-	41D8449	1	Hole plate with strain relief for hand held scanner cable (not shown)

Assembly 18: Countertop

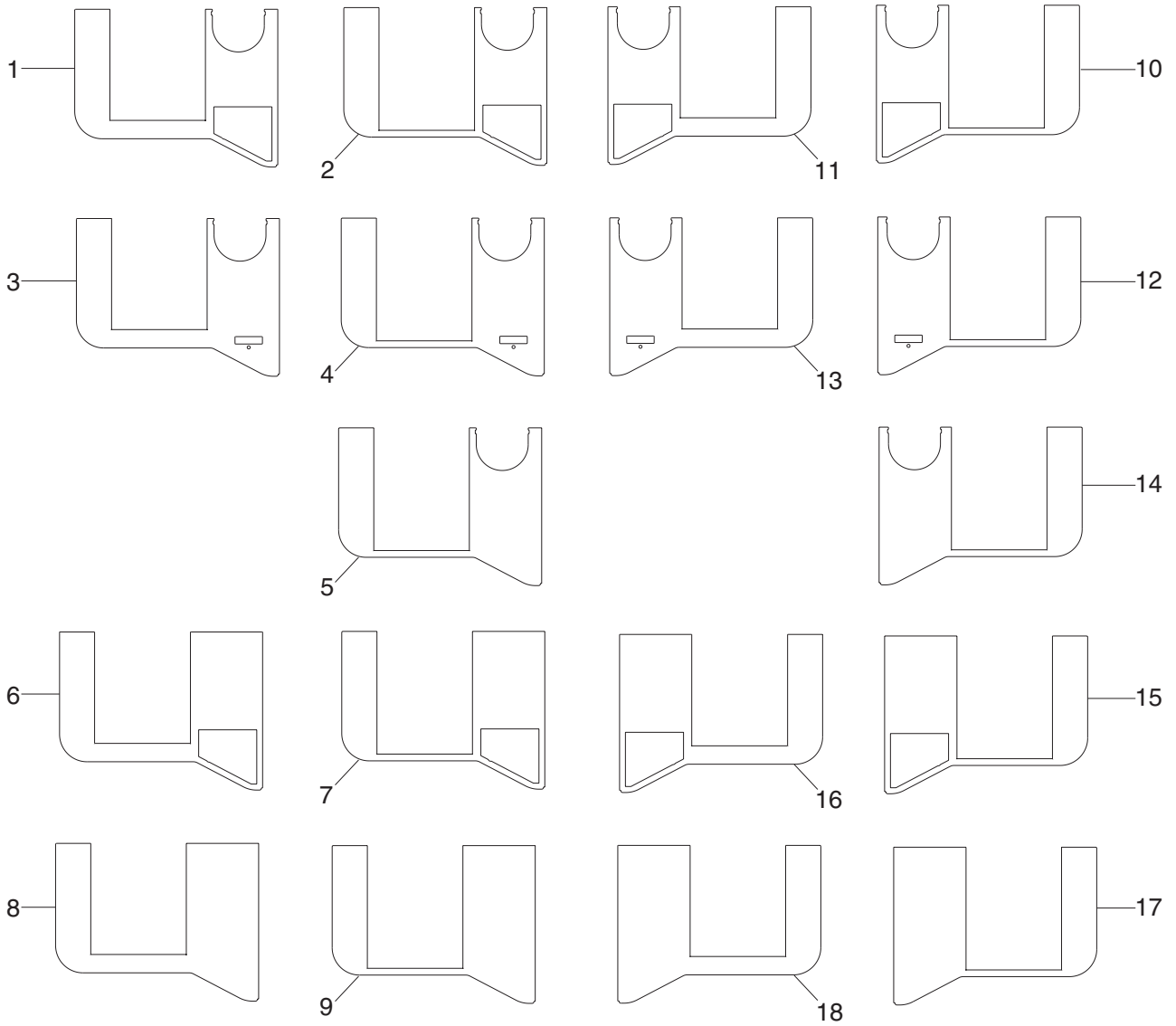

Asm- Index	Part Number	Units	Description
18-1	41E1858	1	Countertop with signature capture, right hand
-2	41J6747	1	Countertop, with signature capture, right hand
-3	41E1861	1	Countertop, no signature capture, right hand
-4	41J6746	1	Countertop, no signature capture, right hand
-5	41D8628	1	Countertop, no signature capture, no coupon, right hand
-6	41D7161	1	Countertop, cashless with signature capture, right hand
-7	41D9626	1	Countertop, cashless with signature capture, right hand
-8	41J7533	1	Countertop, cashless with no signature capture, right hand
-9	41J6745	1	Countertop, cashless with no signature capture, right hand
-10	41J6749	1	Countertop, with signature capture, left hand
-11	41E1859	1	Countertop, with signature capture, left hand
-12	41J6750	1	Countertop, no signature capture, left hand
-13	41E1862	1	Countertop, no signature capture, left hand
-14	41D8630	1	Countertop, no signature capture, no coupon, left hand
-15	41D9628	1	Countertop, cashless with signature capture, left hand
-16	41D7163	1	Countertop, cashless with signature capture, left hand
-17	41J6748	1	Countertop, cashless with no signature capture, left hand
-18	41J7536	1	Countertop, cashless with no signature capture, left hand

Assembly 19: Signature Capture and Coupon Acceptor

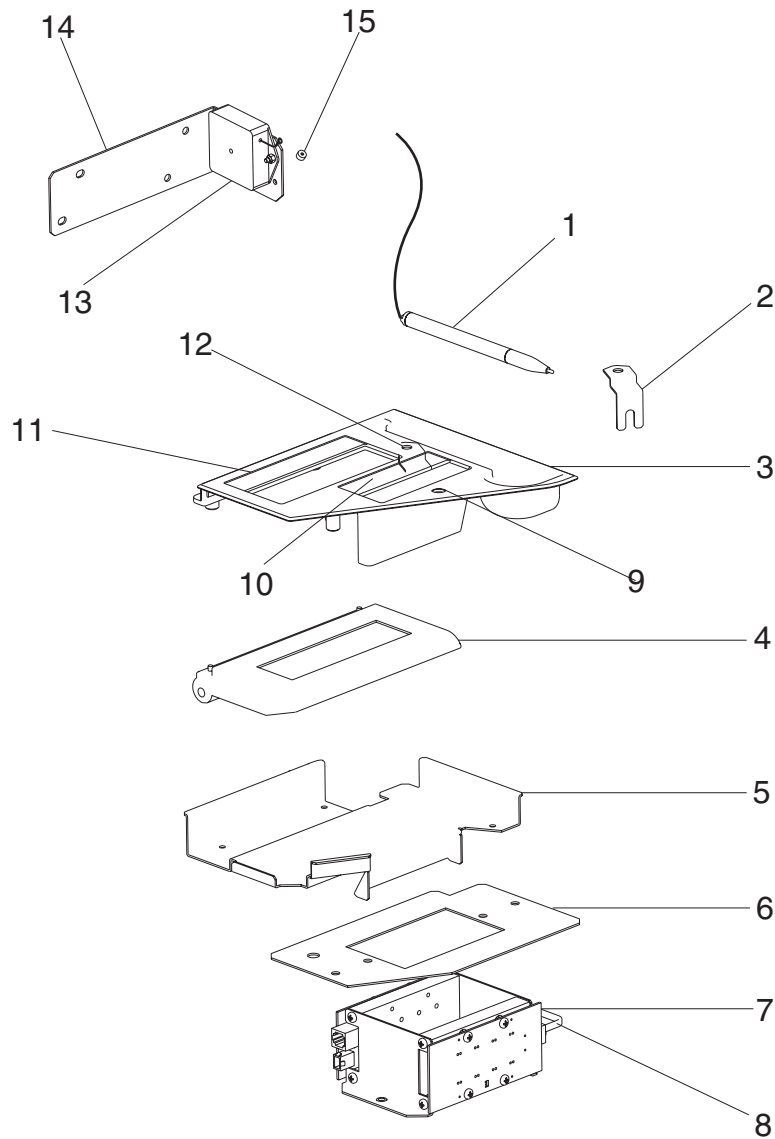

Asm- Index	Part Number	Units	Description
19-			See "How to Use This Parts Manual" on page v for general parts manual information, including ordering parts. See "Identifying a Right Hand or Left Hand Model" on page v for how to identify left hand and right hand models.
-	44D1022	1	Signature capture assembly (right hand) with non-active stylus (also includes bracket, retainer, hex L key)
-	44D1023	1	Signature capture assembly (left hand) with non-active stylus (also includes bracket, retainer, hex L key)
-	44D1130	1	Signature capture assembly (left hand) with active stylus (also includes bracket, retainer, hex L key)
-	44D1131	1	Signature capture assembly (right hand) with active stylus (also includes bracket, retainer, hex L key)
-1	41D9560	1	Active stylus (includes stylus collar 19-15, O ring 19-, split ring 19-, and hex L key 19-)
-1	44D0750	1	Non active stylus (includes stylus collar 19-15)
-1	44D0987	1	Non active stylus (includes stylus collar 19-15, O ring 19-, split ring 19-, and hex L key 19-)
-	44D0989	1	#60 O ring (not shown)
-	44D0991	1	#7 fine split ring (not shown)
-	44D1161	1	M0.9 hex L key (not shown)
-2	41K6576	1	Clip, signature capture
-3	44M1901	1	Signature capture bezel, right hand
-3	44M1902	1	Signature capture bezel, left hand
-4	41D8114	1	Signature capture device
-5	41E1854	1	Signature capture bracket, right hand
-5	41E1855	1	Signature capture bracket, left hand
-	41E1863	1	Filler plate, no signature capture bracket, right hand (not shown)
-	41E1864	1	Filler plate, no signature capture bracket, left hand (not shown)
-6	41E1829	1	Coupon mounting plate
-7	41J7798	1	Coupon emitter/detector assembly
-8	41J9289	1	6 in. RJ11 coupon patch cable
-9	41K6367	1	Coupon indicator assembly
-10	42K0358	1	Label, coupon
-11	42K0357	1	Label, signature
-12	44D1337	1	3/8 in. black nylon hole plug
-13	41J7094	1	Signature capture stylus retractor and collar
-14	41J7093	1	Signature capture stylus retractor bracket
-15	41D9561	1	Stylus collar
-	41E1830	1	Coupon indicator cable from coupon box to the LED (not shown)
-	41E1831	1	Coupon cable from the coupon box to the security controller (not shown)
-	41D1337	1	3/8 in. black nylon hole plug

Assembly 20: Lane light and transaction light

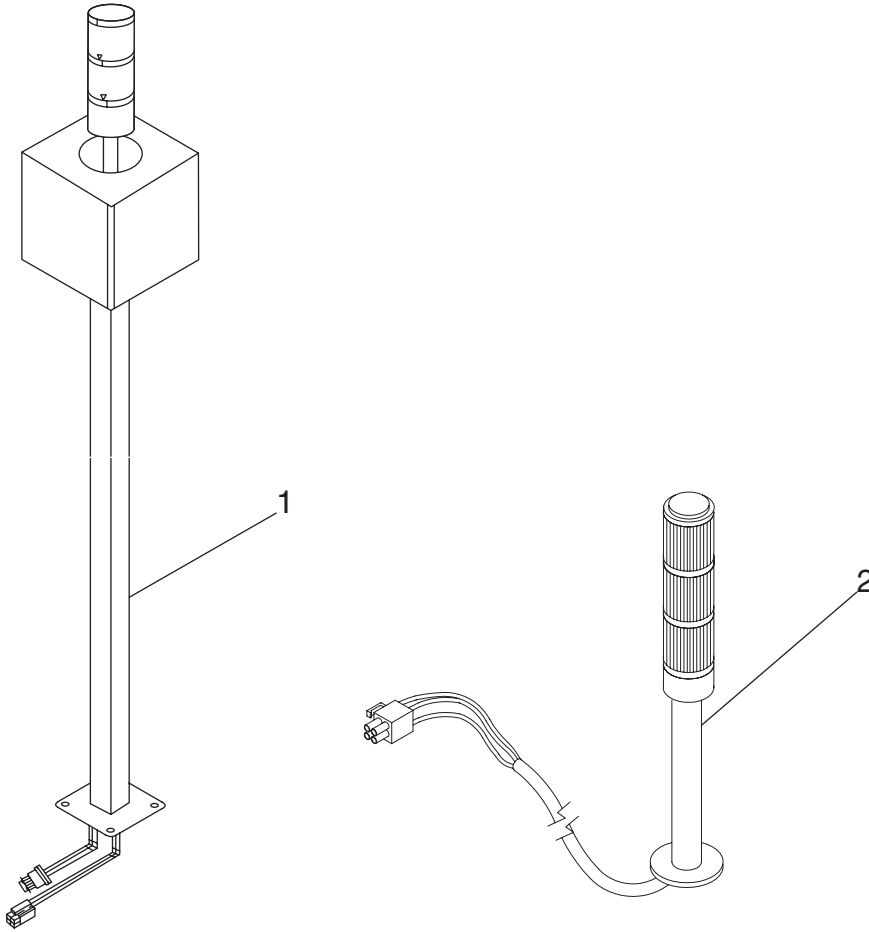

Asm-Index	Part Number	Units	Description
20-			See "How to Use This Parts Manual" on page v for general parts manual information, including ordering parts. See "Identifying a Right Hand or Left Hand Model" on page v for how to identify left hand and right hand models.
-1	41K6371	1	Lane light, with transaction light (English)
-	41D7426	1	Lane light, with transaction light (No text on globe)
-	41D7424	1	Lane light with transaction light (French, Dutch) Carrefour
-	41D7428	1	Lane light (Haggen "Self Scan") (top food banner)
-	41D7430	1	Lane light (Haggen "Self Scan/ 12 items or less") (top food banner)
-	41D8557	1	Lane light assembly, Haggen (Haggen Banner only) "Self Scan / 12 Item or Less" Models 153, 603, and 613
-	41D8555	1	Lane light assembly, Haggen (Haggen Banner) "Self Scan"
-	41J8193	1	Lane light with transaction awareness light assembly, Carrefour, Belgium (French only)
-	41J8194	1	Lane light with transaction awareness light assembly, Carrefour, Belgium (Dutch only)
-	41J8195	1	Lane light with transaction awareness light assembly, Carrefour, Belgium (German/French)
-	44D1232	1	Lane light with 2-tier transaction awareness light assembly and 400mm pole
-	41D8054	1	Cable, lane light power adapter
-	41D7557	1	Lens, red transaction light
-	41E1865	1	Cover plate, lane light (used when no lane light is present)
-	41D7656	1	Bulb 12 Vdc, transaction light
-2	41D7704	1	Transaction awareness light, 2-tier
-2	41D7706	1	Transaction awareness light, 3-tier
-2	41D7977	1	Transaction awareness light, 3-tier, Carrefour France (green, red, amber)
-2	44D0421	1	Transaction awareness light, 3-tier, Costco
-	41D8056	1	Cable, transaction awareness light
-	44M1884	1	Lane light mounting clamp (not shown, used when lane light is mounted on Models 152, 602, and 612 bagging module)
-	44M1886	1	Lane light mounting strap (not shown, used when lane light is mounted on Models 152, 602, and 612 bagging module)

Assembly 21: Lane PC, Mouse, and Keyboard

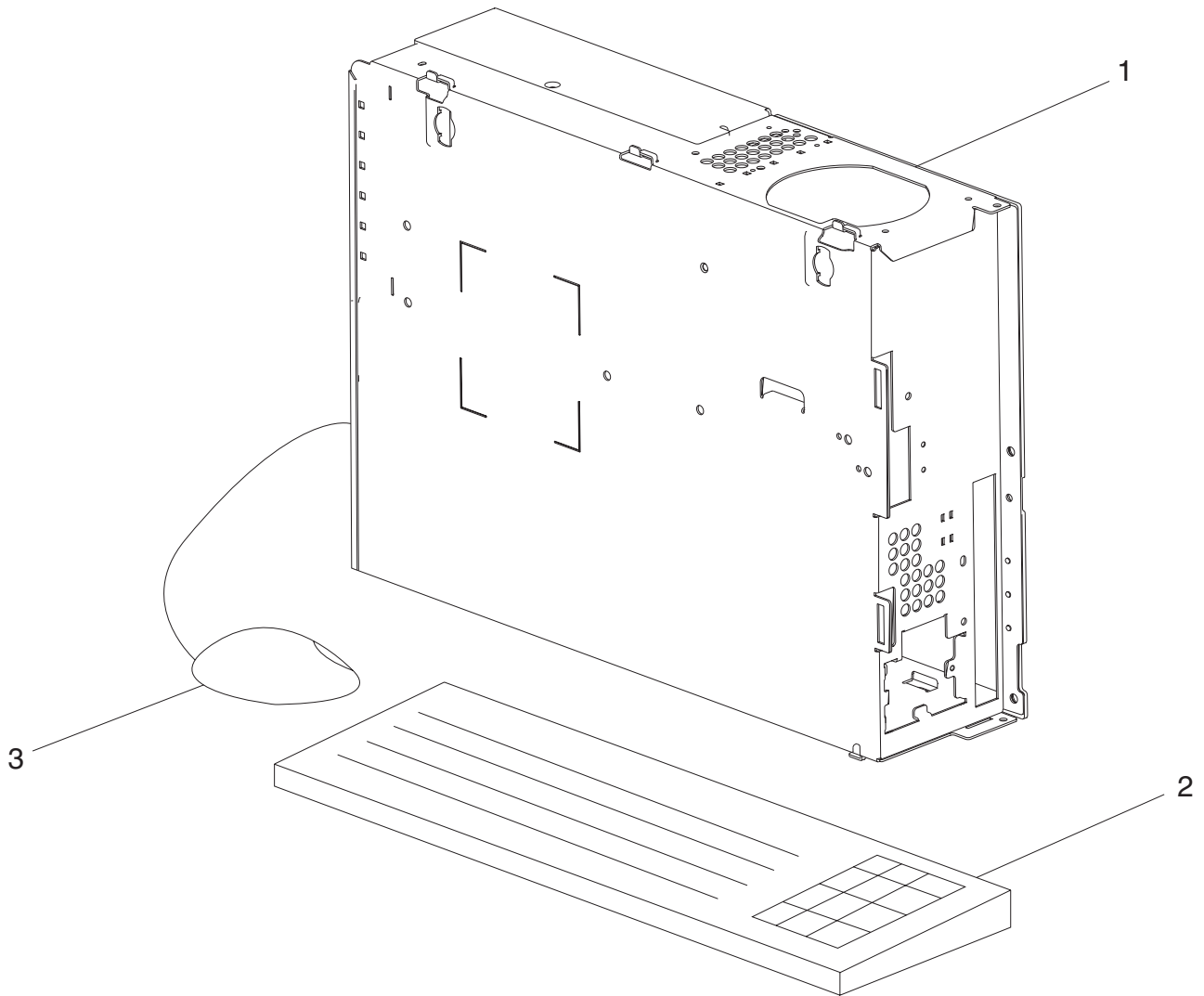

Asm-Index	Part Number	Units	Description
21-			See "How to Use This Parts Manual" on page v for general parts manual information, including ordering parts. See "Identifying a Right Hand or Left Hand Model" on page v for how to identify left hand and right hand models.
-1		1	Lane PC, IBM 4800-742 MFI. Refer to <i>IBM 4800 SurePOS 720, 740, and 780 Hardware Service Guide, SA27-4329</i> for lane PC information.
I -2	32N1205	1	Keyboard, Black, US English USB, #103P, PS/2 key layout, 3m cable
I -2	32N1206	1	Keyboard, Black, French USB, #189, PS/2 key layout, 3m cable
I -2	32N1207	1	Keyboard, Black, Italian USB, #142, PS/2 key layout, 3m cable
I -2	32N1208	1	Keyboard, Black, German/Austrian USB, #129, PS/2 key layout, 3m cable
I -2	32N1209	1	Keyboard, Black, UK English USB, #166, PS/2 key layout, 3m cable
I -2	32N1210	1	Keyboard, Black, Spanish USB, #172, PS/2 key layout, 3m cable
I -2	32N1216	1	Keyboard, Black, French Canadian USB, #445, PS/2 key layout, 3m cable
I -2	32N1218	1	Keyboard, Black, Belgian/UK, #120, USB, PS/2 key layout, 3m cable
I -2	32N1220	1	Keyboard, Black, Danish USB, #159, PS/2 key layout, 3m cable
I -2	32N1224	1	Keyboard, Black, Dutch USB, #143, PS/2 key layout, 3m cable
I -2	32N1236	1	Keyboard, Black, Slovenian USB, #234, PS/2 key layout, 3m cable
I -2	10N9421	1	Keyboard, Black, Brazilian Portuguese USB, #275, PS/2 key layout, 3m cable
I -2	10N9422	1	Keyboard, Black, Hungarian USB, #208, PS/2 key layout, 3m cable
I -2	10N9428	1	Keyboard, Black, Swedish/Finnish USB, #153, PS/2 key layout, 3m cable
I -2	10N9431	1	Keyboard, Black, Swiss, French/German USB, #150F/G, PS/2 key layout, 3m cable
I -2	10N9432	1	Keyboard, Black, Norwegian USB, #155, PS/2 key layout, 3m cable
I -2	10N9434	1	Keyboard, Black, Portuguese USB, #163, PS/2 key layout, 3m cable
I -2	10N9435	1	Keyboard, Black, Greek USB, #319, PS/2 key layout, 3m cable
I -2	10N9437	1	Keyboard, Black, Polish USB, #214, PS/2 key layout, 3m cable
I -2	10N9439	1	Keyboard, Black, Czech USB, #243, PS/2 key layout, 3m cable
I -2	10N9440	1	Keyboard, Black, Turkish USB, #179, PS/2 key layout, 3m cable
I -2	10N9441	1	Keyboard, Black, LA Spanish USB, #171, PS/2 key layout, 3m cable
-3	03N6669	1	USB 3-Button mouse
-	41D7596	1	HASP ISS-45 POS software key

Chapter 2. Load Cells, Platens, Plates, and Retaining Fences

Assembly 22: Load Cell.	54
Assembly 23: Platens and Retaining Fences	56

Assembly 22: Load Cell

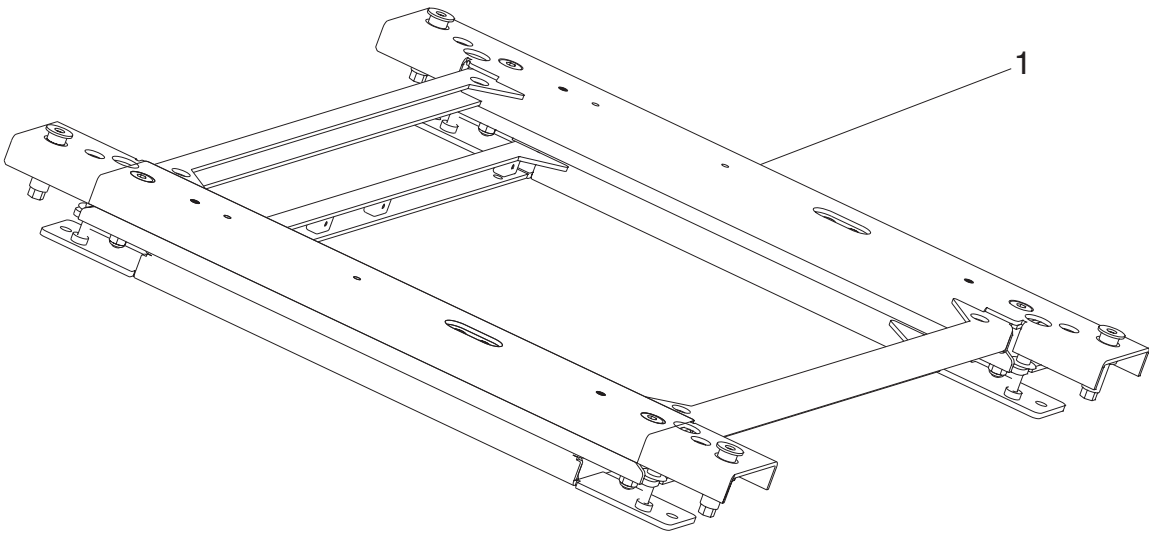

Asm-Index	Part Number	Units	Description
22-			See "How to Use This Parts Manual" on page v for general parts manual information, including ordering parts. See "Identifying a Right Hand or Left Hand Model" on page v for how to identify left hand and right hand models.
-1	41D7448	1	Load cell, 1 bag position (Model N54)
-1	41D7451	1	Load cell, Models 152, 153, 171, 602, 612, 603, 613, 800, 810 (replaces 41J8098)
-1	41D7453	1	Load cell, 100 KG, Models 171, 800, and 810 (for wide lane with 25 inch belt)
-1	41D8188	1	Load cell, Models 151, 606, and 616 Carousel
-1	41D7622	1	Load cell, Models 151, 606, and 616 secondary shelf
-	41D7621	1	Digital carousel weighting assembly with load cells, frame, platen, cables, control box, Models 151, 606, and 616
-	41D8291	4	Screw, M6 X 55 (attaches load cell to conveyor) Models 171, 800, and 810
-	41J6930	2	Adapter bar, (attaches load cell to conveyor, for wide lane with 25 inch belt)
-	41J6934	2	Guide, load cell plastic, Models 171, 800, and 810 (for standard lane with 19 inch belt)
-	41J7417	2	Guide, load cell plastic, Models 171, 800, and 810 (for wide lane with 25 inch belt)
-	41D7073	2	Cable, 6 foot, DB9, male/female, used for load cell extension

Assembly 23: Platens and Retaining Fences

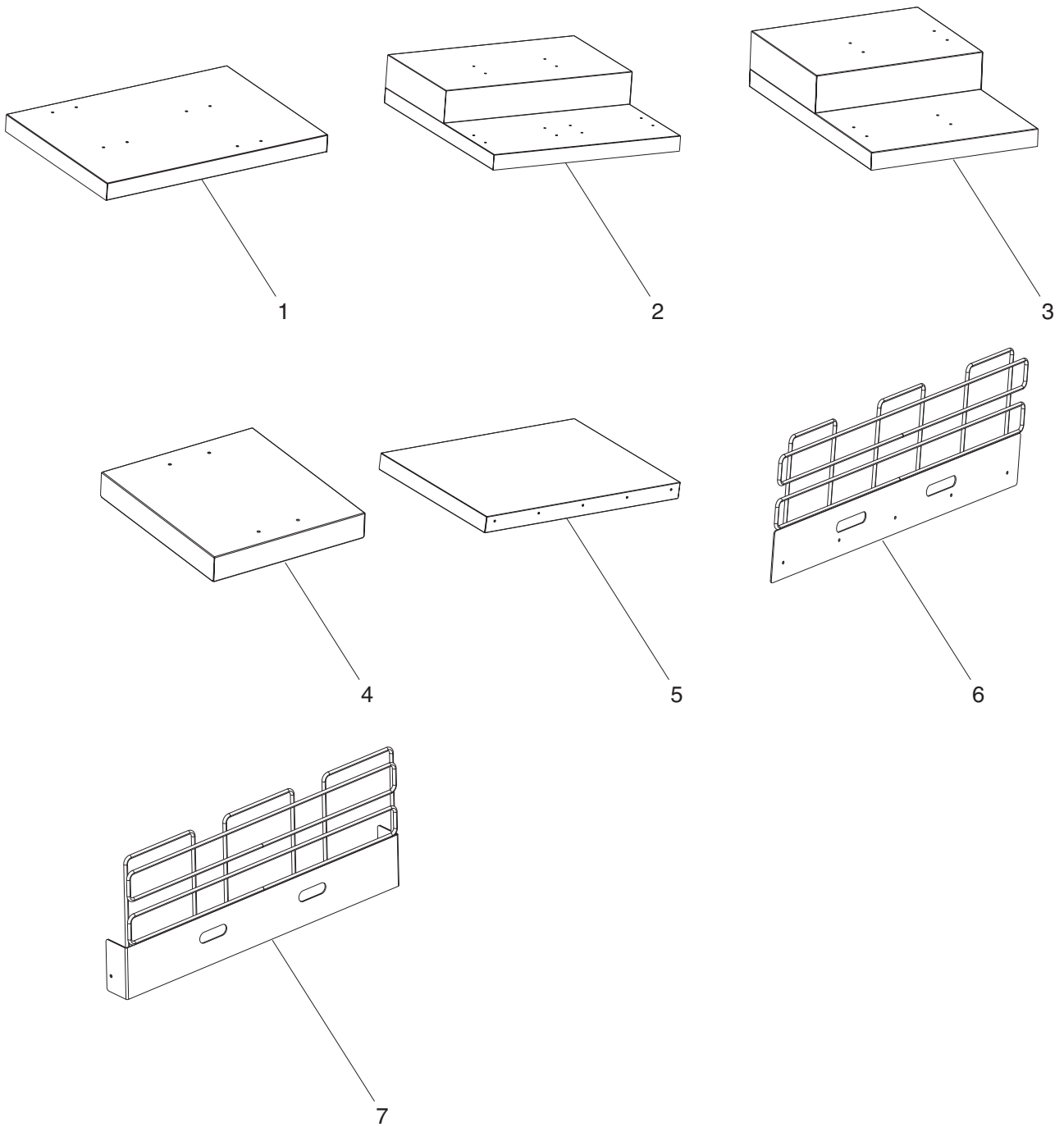

Asm-Index	Part Number	Units	Description
23-			See "How to Use This Parts Manual" on page v for general parts manual information, including ordering parts. See "Identifying a Right Hand or Left Hand Model" on page v for how to identify left hand and right hand models.
-1	41D7323	1	Flat platen with 2 bag hole pattern, right hand, Models 152, 602, and 612
-	41D7324	1	Flat platen with 2 bag hole pattern, left hand, Models 152, 602, and 612
-2	41D7636	1	Platen for Models 153, 603, and 613, tiered, 3 bag hole pattern, right hand/left hand
-	41D8184	1	Platen, for Models 151, 606, and 616 Carousel (round platen)
-3	41D7635	1	Platen for Model Models 152, 602, and 612, tiered, 2 bag hole pattern, right hand
-	41D9327	1	Platen for Models 152, 602, and 612, tiered, 2 bag hole pattern, left hand
-4	41J9748	1	Platen, flat, 1 bag hole pattern, right hand/left hand, Model N54
-			Platen tower See 26-4 on page 71.
-	41D8196	1	Platen assembly Models 151, 606, and 616 Carousel side shelf
-5	41D7667	1	Platen, flat, Models 152, 602, and 612
-6	41D7669	1	Fence, long retaining, Models 152, 602, and 612 (for use with Models 152, 602, and 612 flat platen)
-7	41D7671	1	Fence, short retaining, Models 152, 602, and 612 (for use with Models 152, 602, and 612 flat platen)

Chapter 3. Security Conveyor

Assembly 24: Security Conveyor	60
--	----

Assembly 24: Security Conveyor

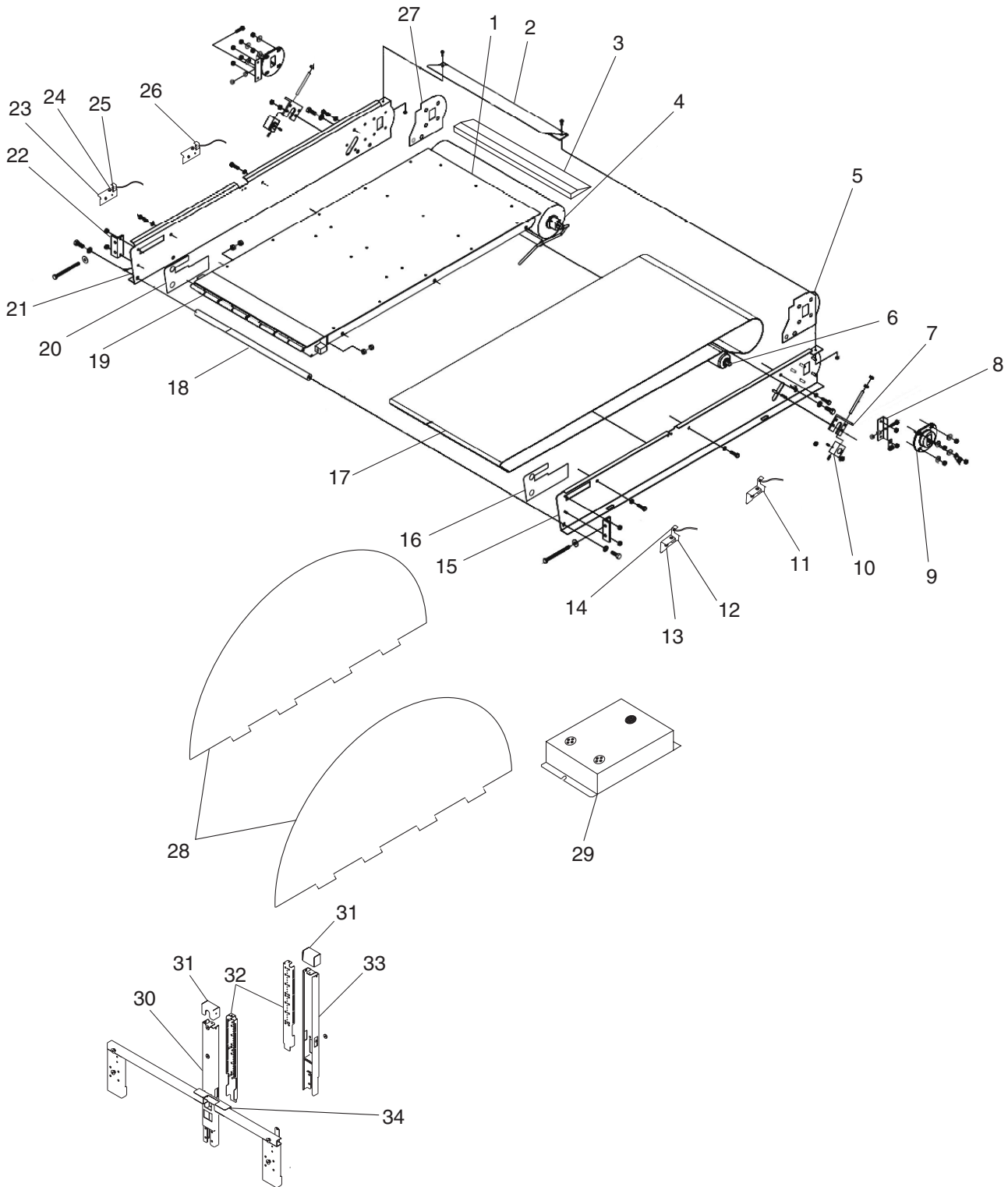

Asm- Index	Part Number	Units	Description
24-			See "How to Use This Parts Manual" on page v for general parts manual information, including ordering parts. See "Identifying a Right Hand or Left Hand Model" on page v for how to identify left hand and right hand models.
-	41J7432	1	Security conveyor assembly, 19 in., 115V
-	41J7436	1	Security conveyor assembly, 19 in., 230V
-	41J7440	1	Security conveyor assembly, 25 in., 115V
-	41J7444	1	Security conveyor assembly, 25 in., 230V
-1	41J8791	1	Skid plate (for standard lane with 19 inch belt)
-1	41J8896	1	Skid plate (for wide lane with 25 inch belt)
-2	41J9127	1	Plate, front transition, with sensors (for standard lane with 19 inch belt)
-2	41J8340	1	Plate, front transition, with sensors (for wide lane with 25 inch belt)
-2	41J8848	1	Plate, front transition (for wide lane with 25 inch belt) (includes support bracket)
-3	41D9782	1	Card stop bracket (mounted under the transition plate) (for standard lane with 19 inch belt)
-3	41J8867	1	Card stop bracket (mounted under the transition plate) (for wide lane with 25 inch belt)
-4	41J9312	1	Motorized pulley, 19" security conveyor 115V-60hz, balanced
-4	41D9816	1	Motorized pulley, 19" security conveyor 230V-50hz, balanced
-4	41J9320	1	Motorized pulley, 25" security conveyor 115V-60hz, balanced
-4	41D9822	1	Motorized pulley, 25" security conveyor 230V-50hz, balanced
-5	28R3196	1	Guide, tracking, nose end (order with 28R3195). Adhesive plastic sticker. Reduces friction between belt and metal sides.
-6	28R3298	1	Roller, idler (for standard lane with 19 inch belt)
-6	28R3275	1	Roller, idler (for wide lane with 25 inch belt)
-7	28R3284	2	Angle adjuster (one on each side)
-8	28R3285	2	Drive roller retaining angle (one on each side)
-9	41J7666	2	Bracket, drive isolation. Large black coupling. Use to adjust and isolate motor. (one on each side)
-10	28R3283	2	Block, idler roller (one on each side)
-11	41J9845	1	Emitter, flat pack sensor assembly, replaces 40M9507, (Flat pack sensor assemblies for the emitter and detector should be replaced as a set. Order 41J9849 detector.)
-12	41J9845	1	Exit sensor emitter (for standard lane with 19 inch belt)
-12	41J8344	1	Exit sensor emitter (for wide lane with 25 inch belt)
-	41J8854	1	Sensor cable, transition plate (not shown)
-13	41J8850	1	2nd emitter mounting bracket
-14	41D9783	1	Exit sensor mounting bracket
-15	28R3191	1	Plate, conveyer, left side (for standard lane with 19 inch belt)
-15	28R3277	1	Plate, conveyer, left side (for wide lane with 25 inch belt)
-16	28R3194	1	Guide, tracking, motor end (order with 28R3197). Adhesive plastic sticker. Reduces friction between belt and metal sides.
-17	28R3192	1	Belt, security conveyor, with roller (for standard lane with 19 inch belt)
-17	28R3278	1	Belt, security conveyor, with roller (for wide lane with 25 inch belt)
-18	41J8338	1	Crossbar, conveyor frame (for standard lane with 19 inch belt) Aluminum bar. (Replaces 28R3180)
-18	28R3279	1	Crossbar, conveyor frame (for wide lane with 25 inch belt)
-19	41J7448	1	Nose bar assembly (for standard lane with 19 inch belt)
-19	41J7450	1	Nose bar assembly (for wide lane with 25 inch belt)
-20	28R3195	1	Guide, tracking, motor end (order with 28R3196). Adhesive plastic sticker. Reduces friction between belt and metal sides.
-21	28R3190	1	Plate, conveyer, right side (for standard lane with 19 inch belt)
-21	28R3276	1	Plate, conveyer, right side (for wide lane with 25 inch belt)
-22	28R3172	1	Nose bar angle adjuster

Asm-Index	Part Number	Units	Description
-23	41J8869	1	2nd detector mounting bracket
-24	41D9783	1	Exit sensor mounting bracket
-25	41J9849	1	Exit sensor detector (for standard lane with 19 inch belt)
-25	41J8342	1	Exit sensor detector (for wide lane with 25 inch belt)
-26	41J9849	1	Detector, flat pack sensor assembly, replaces 40M9508, (Flat pack sensor assemblies for the emitter and detector should be replaced as a set. Order 41J9845 emitter.)
-27	28R3197	1	Guide, tracking, motor end (order with 28R3194). Adhesive plastic sticker. Reduces friction between belt and metal sides.
-	41J7676		M6 x 19 Black screw for security shield (not shown)
-28	41J7678	2	Security shield
-29	41J9544	1	Capacitor box, 230V
-29	41J9546	1	Capacitor box, 115V
-	40M9423	1	Capacitor box cable (provides power to the conveyor motors) (not shown)
-30	41D9785	1	Curtain support, RH (for standard lane with 19 inch belt)
-30	41D9786	1	Curtain support, RH (for wide lane with 25 inch belt)
-30	41D9803	1	Curtain support, LH (for standard lane with 19 inch belt)
-30	41D9804	1	Curtain support, LH (for wide lane with 25 inch belt)
-32	41D9784	1	Cap, tower (one on each side)
-32	44M2189	1	Curtain detector/emitter sensor assembly (matched set) (located in the curtain tower)
-33	41D9787	1	Tower, rear curtain support (for standard lane with 19 inch belt)
-33	41D9788	1	Tower, rear curtain support (for wide lane with 25 inch belt)
-34	44M2232	1	Curtain guard, customer side (for wide lane with 25 inch belt)
-	41J8414	4	Cable, curtain sensor fanout dongle (not shown)
-	41J8336	1	Wire cord clips (bag of 10)
-	42H1161	1	Cable tie (not shown)
-			NOTE: Hardware items such as screws, bolts, nuts, and washers removed during the disassembly of parts should be retained for use during re-assembly of those parts. Screws, bolts, nuts, and washers can not be ordered separately, they are available as part of a field kit. See Chapter 12, "Field Kits and Tools," on page 101 for a listing of screws, bolts, nuts, and washers contained in each field kit.
-	41E1748	4	Transition plate extension cable
-	41E1749	2	Sensor extension cable

Chapter 4. Transport Conveyor

Assembly 25: Transport Conveyor 64

Assembly 25: Transport Conveyor

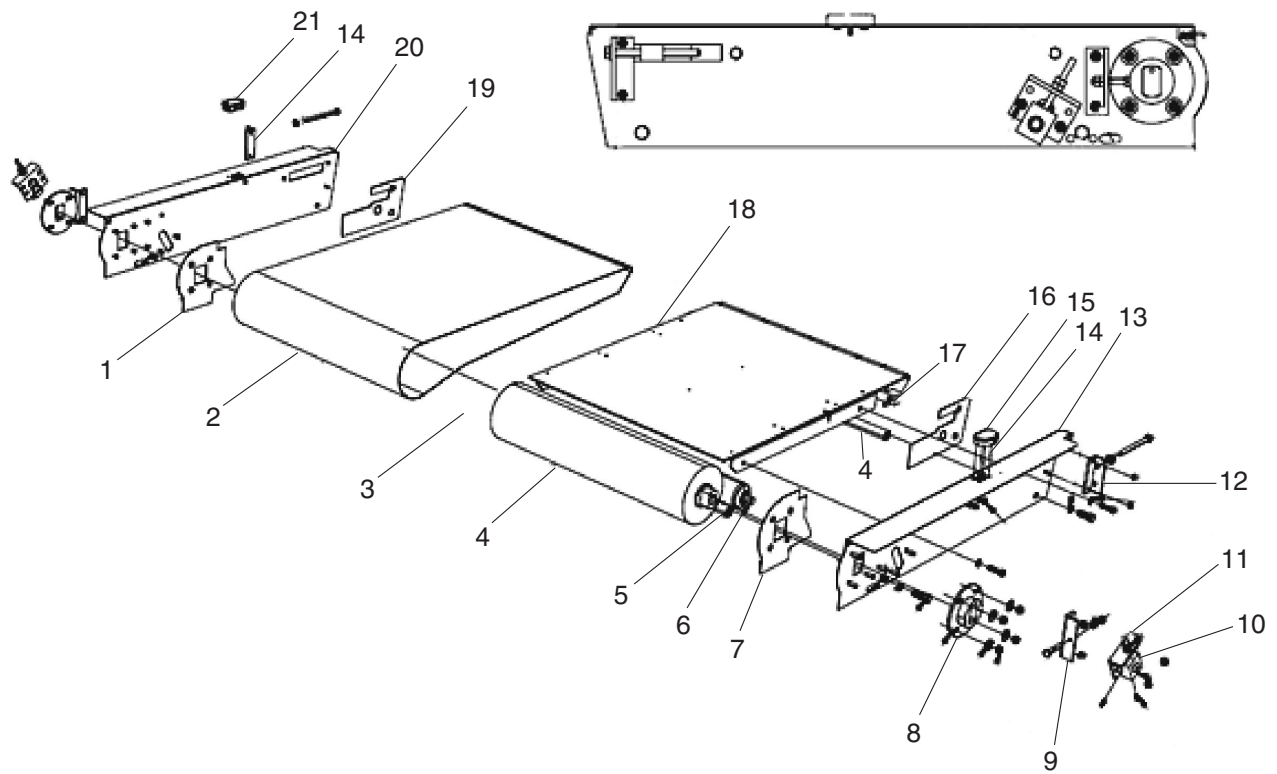

Asm- Index	Part Number	Units	Description
25-			See "How to Use This Parts Manual" on page v for general parts manual information, including ordering parts. See "Identifying a Right Hand or Left Hand Model" on page v for how to identify left hand and right hand models.
-	41J7434	1	Transport conveyor assembly, 19 in., 115V
-	44M1899	1	Transport conveyor assembly with Sensormatic, 19 in., 115V, right hand
-	44M1900	1	Transport conveyor assembly with Sensormatic, 19 in., 115V, left hand
-	41J7438	1	Transport conveyor assembly, 19 in., 230V
-	41J7442	1	Transport conveyor assembly, 25 in., 115V
-	44D0405	1	Transport conveyor assembly with Sensormatic, 25 in., 115V, right hand
-	44D0407	1	Transport conveyor assembly with Sensormatic, 25 in., 115V, left hand
-	41J7446	1	Transport conveyor assembly, 25 in., 230V
-1	28R3196	1	Guide, tracking, motor end (order with 28R3195). Adhesive plastic sticker.
-2	28R3189	1	Belt, transport conveyor (for standard lane with 19 inch belt)
-2	28R3274	1	Belt, transport conveyor (for wide lane with 25 inch belt)
-3	41D9769	1	LED light visor mount (not shown, located on motor cable)
-4	41J9310	1	Motorized pulley, 19" conveyor 115-60hz, unbalanced (transport only)
-4	41D9818	1	Motorized pulley, 19" transport conveyor 230V
-4	41J9318	1	Motorized pulley, 25" conveyor 115-60hz, unbalanced (transport only)
-4	41D9820	1	Motorized pulley, 25" transport conveyor 230V
-5	41J8438	1	Crossbar, conveyor frame (for standard lane with 19 inch belt)
-5	28R3279	1	Crossbar, conveyor frame (for wide lane with 25 inch belt)
-6	28R3298	1	Roller (for standard lane with 19 inch belt)
-6	28R3275	1	Roller (for wide lane with 25 inch belt)
-7	28R3197	1	Guide, tracking, motor end (order with 28R3194). Adhesive plastic sticker.
-8	41J7666	2	Bracket, drive isolation. Large black coupling. Use to adjust and isolate motor. (one on each side)
-9	28R3285	2	Drive roller retaining angle (one on each side)
-10	28R3283	2	Block, idler roller (one on each side)
-11	28R3284	2	Bracket, tensioner (one on each side)
-12	28R3172	1	Nosebar adjusting angle
-13	41J7426	1	Plate, side, transport conveyor, left side
-14	41J6928	1	Emitter/detector bracket, bagging area full sensor
-15	41D7146	1	Emitter, bagging area full sensor (for standard lane with 19 inch belt)
-15	41J8450	1	Emitter, bagging area full sensor (for wide lane with 25 inch belt)
-16	28R3195	1	Guide, tracking, motor end (order with 28R3196). Adhesive plastic sticker.
-17	41J7448	1	Assembly, nosebar, (for standard lane with 19 inch belt) (Replaces 28R7098)
-17	41J7450	1	Assembly, nosebar, (for wide lane with 25 inch belt) (Replaces 28R7084)
-18	41J8332	1	Skid plate, (for standard lane with 19 inch belt), no Sensormatic
-18	44M1913	1	Skid plate with Sensormatic opening, (for standard lane with 19 inch belt), right hand
-18	44M1914	1	Skid plate with Sensormatic opening, (for standard lane with 19 inch belt), left hand
-18	41J8334	1	Skid plate, (for wide lane with 25 inch belt), no Sensormatic
-19	28R3194	1	Guide, tracking, motor end (order with 28R3197). Adhesive plastic sticker.
-20	41J7425	1	Plate, side, transport conveyor, right side plate
-21	41D7150	1	Detector, bagging area full sensor (for standard lane with 19 inch belt)
-21	41J8452	1	Detector, bagging area full sensor (for wide lane with 25 inch belt)
-	41J7126	1	25 inch order separator (not shown). See 42-1 on page 121.
-	41J7127	1	19 inch order separator (not shown). See 42-1 on page 121.
-	41J8854	1	Sensor cable, transition plate (not shown)
-	41J8855	1	Transition plate emitter (not shown)
-	41J8856	1	Transition plate detector (not shown)
-	42H1161	1	Cable tie (not shown)
-	41J8336	1	Wire cord clips (bag of 10)

Asm- Index	Part Number	Units	Description
-			<p>NOTE: Hardware items such as screws, bolts, nuts, and washers removed during the disassembly of parts should be retained for use during re-assembly of those parts. Screws, bolts, nuts, and washers can not be ordered separately, they are available as part of a field kit. See Chapter 12, "Field Kits and Tools," on page 101 for a listing of screws, bolts, nuts, and washers contained in each field kit.</p>

Chapter 5. Bagging and Carousel Bagging

Assembly 26: Carousel parts 70

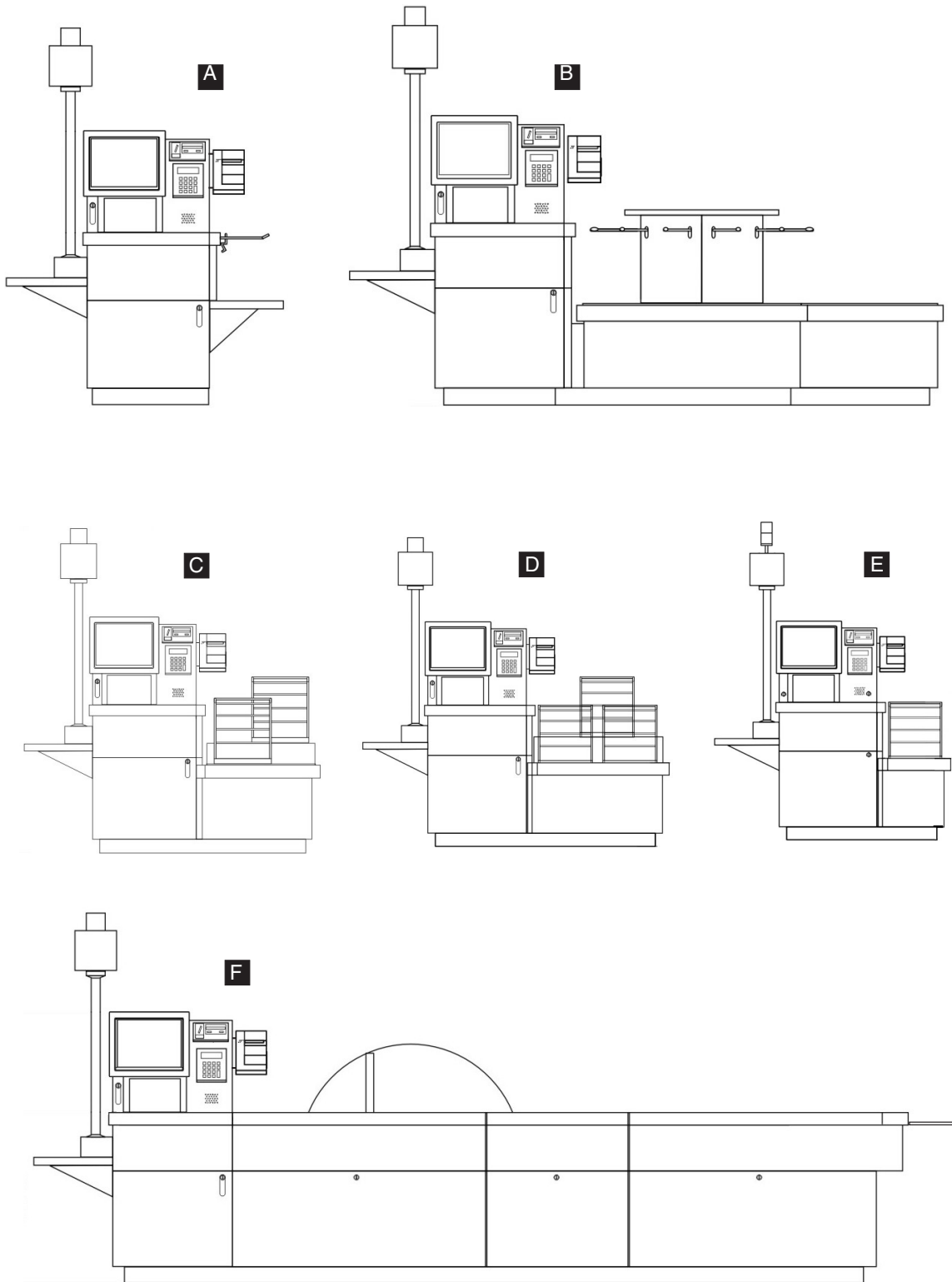

Figure 2. Self Checkout bagging options

Contact your IBM parts center for bagging parts. Be sure to have the correct model name and store name when ordering parts. See “How to Use This Parts Manual” on page v for general parts manual information, including ordering parts. See “Identifying a Right Hand or Left Hand Model” on page v for how to identify left hand and right hand models.

The bagging options are:

Table 1.

Key	Description
A	Model 131, bagging rack attached to the core module
B	Models 151, 606, and 616, 6 bagging stations on a carousel
C	Models 152, 602, and 612, 2 bagging stations
D	Models 153, 603, and 613, 3 bagging stations
E	Model N54 Express-Plus, 1 bagging station
F	Models 171, 800, and 810 Full Lane, a transport conveyor that delivers items to a bagging area

Assembly 26: Carousel parts

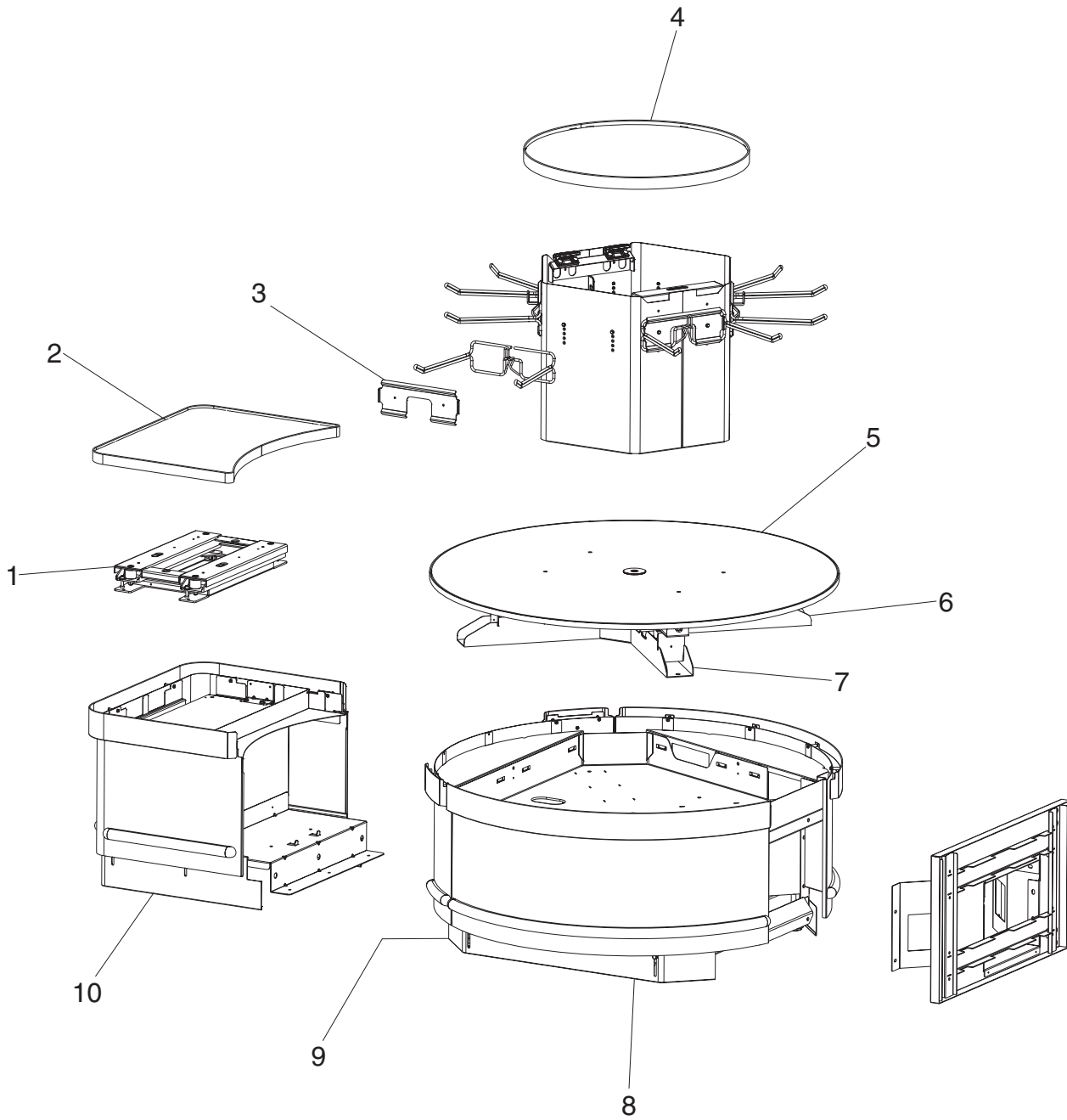

Asm-Index	Part Number	Units	Description
26-1		1	Load cell. See 22-1 on page 55.
-2			Platen, carousel side shelf. See assembly 23- on page 57.
-3	41D9744	1	Carousel bag pack clamping plate
I -4	41D8195	1	Lid tower, Models 151, 606, and 616 Carousel, round small
-	41D7621	1	Carousel assembly contains:
-5			• Platen, carousel round. See 23- on page 57.
-6			• Load cell, carousel. See 22-1 on page 55.
I -7	41D8194	1	• Wheel assembly Models 151, 606, and 616 carousel, plastic
I -8	44M1975	1	Kickplate, front/rear, for Models 151, 606, and 616 carousel
I -9	44M1976	1	Kickplate, side, for Models 151, 606, and 616 carousel
I -10	44M1977	1	Kickplate, shelf, for Models 151, 606, and 616 carousel
I -	41D8185	1	Lower bushing kit, Models 151, 606, and 616 carousel (not shown)
-	41D8187	1	Carousel parts kit, contains - 4 M8x10 hex socket screws, 4 rubber buffers 30x25xM8, 1 grounding spring, 4 shims frolic 1026D, 4 Phil pan head screws NC 6x1", 8 M6x35 hex socket screws, 1 bearing, 8 socket head shoulder screws (M8), 1 upper bushing, 1 nylon locking nut, 1 plastic plug transparent
I -	41D8190	1	Electrical interface box for Models 151, 606, and 616 carousel (not shown)
I -	41D8192	1	Cable, Models 151, 606, and 616 carousel data communication (not shown)
I -	41D8193	1	Power supply Models 151, 606, and 616 carousel, 120/9V external (not shown)

Chapter 6. Wire Bag Rack

Assembly 27: Wire Bag Rack	74
--------------------------------------	----

Assembly 27: Wire Bag Rack

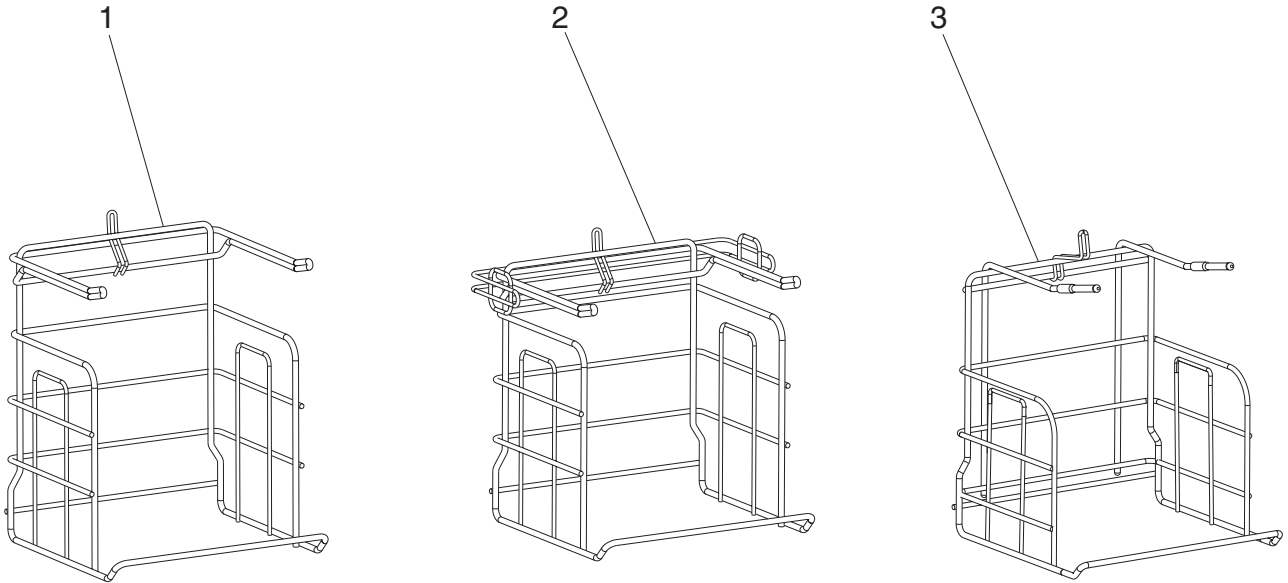

Asm- Index	Part Number	Units	Description
27-1	28R3173		(28R3167) Tall rack
-2	28R5540		(28R5697) Short rack
-3	41K7093		(41K7092) European rack
-	41D8560		(41D8559) Rack clamp (not shown)

Chapter 7. BOSS

Assembly 28: BOSS FRUs	78
----------------------------------	----

Assembly 28: BOSS FRUs

Asm- Index	Part Number	Units	Description
28-	23K8035	1	Cover, I/O blank
-	41A3391	1	Riser card, 2 PCI slots
-			Lane PC. See "Assembly 21: Lane PC, Mouse, and Keyboard" on page 50. Monitor/display. See 1-4 on page 3. Magnetic stripe reader. See 1-5 on page 3. Power strip. See 1-37 on page 4. Power supply. See 1-34 on page 4. Printer. See "Assembly 12: Printers Tlx and TGx" on page 28.

Chapter 8. Integrated Paystation

Assembly 29: Paystation	82
-----------------------------------	----

Assembly 29: Paystation

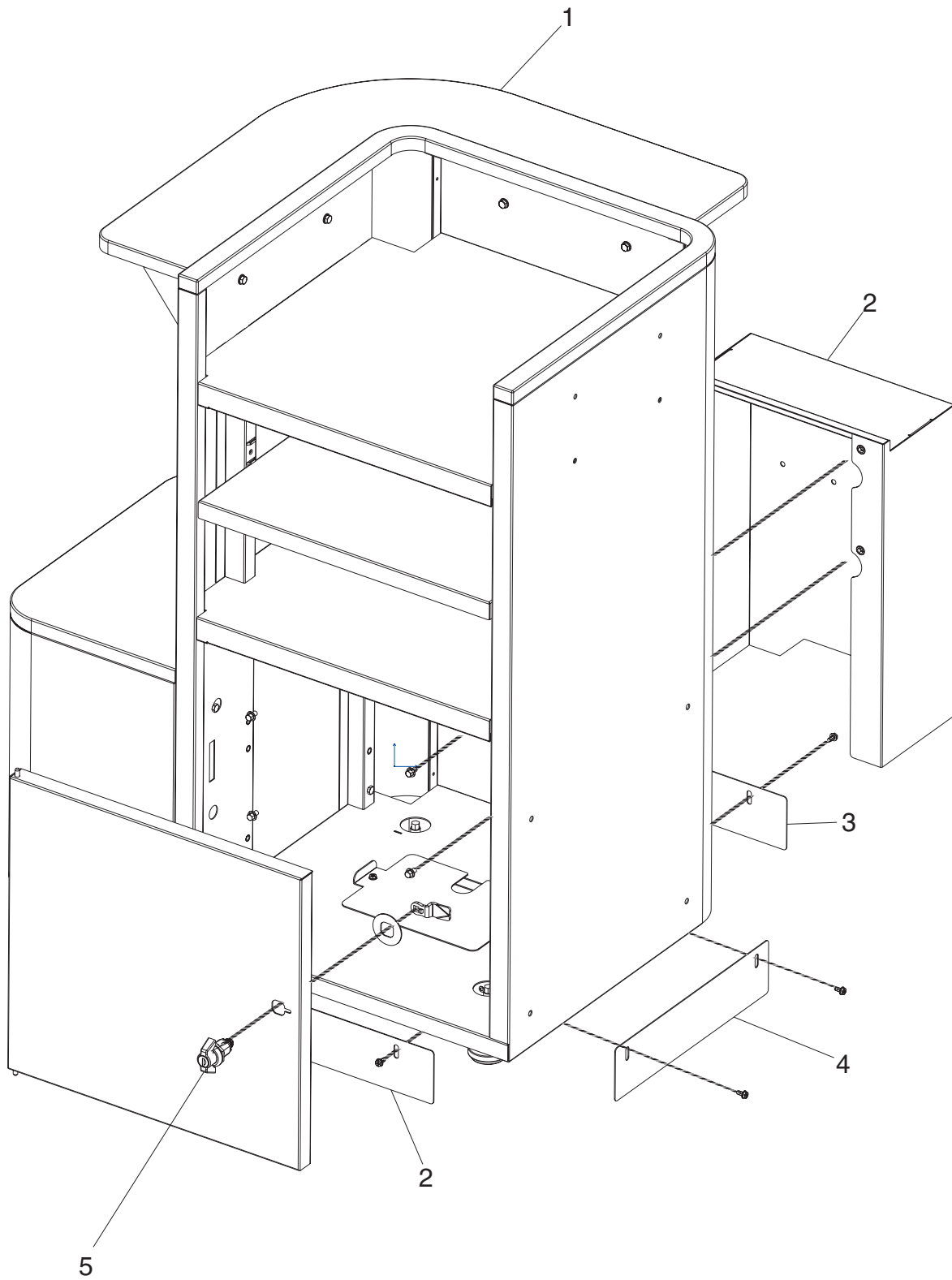

Asm- Index	Part Number	Units	Description
29-	41D8116	1	Stabilizer, paystation front/rear (not shown)
-	41D8118	1	Stabilizer, paystation side (not shown)
-1	41D7391	1	Paystation shelf
-2	41D7320	1	Integrated Paystation interface plate/cable cover
-3	44D0861	1	Integrated Paystation front/rear kickplate
-4	44D0862	1	Integrated Paystation left/right side kickplate
-5		1	Keylock, cabinet lock with key. See Chapter 11, "Locks and Keys," on page 95.

Chapter 9. EPO (Red) Button

Assembly 30: EPO (Red) Button	86
---	----

Assembly 30: EPO (Red) Button

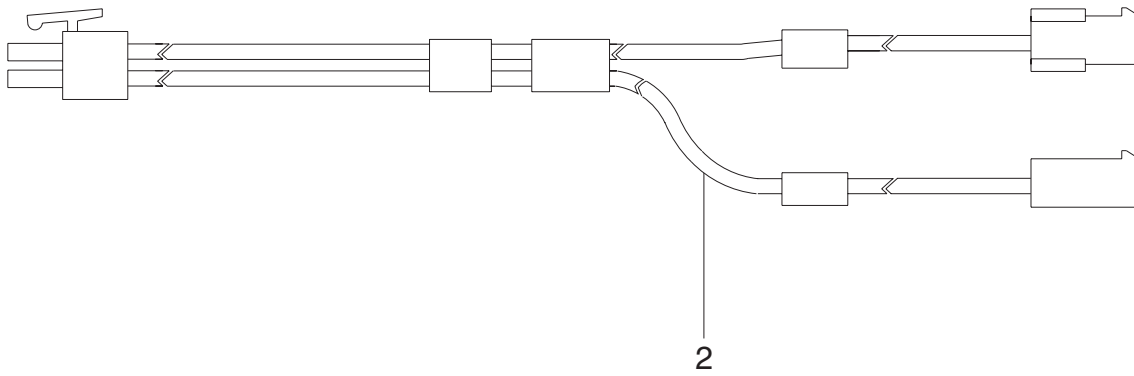
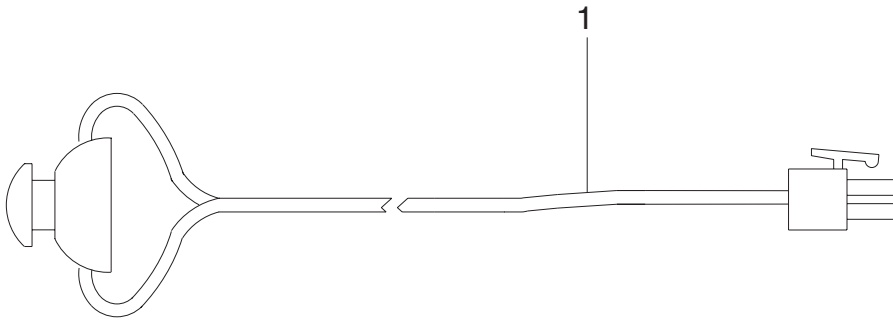

Asm- Index	Part Number	Units	Description
30-1	41K7082	1	EPO button (red) button cable assembly (EPO button mounted on top of upper core module door for certain customers)
-2	41K7080	1	Reset (green) and EPO (red) buttons Y cable (used with 41K7082 instead of 40M9470 1-2 on page 3)

Chapter 10. Cables

Assembly 31: Cables	90
Assembly 32: Power Cords	92

Assembly 31: Cables

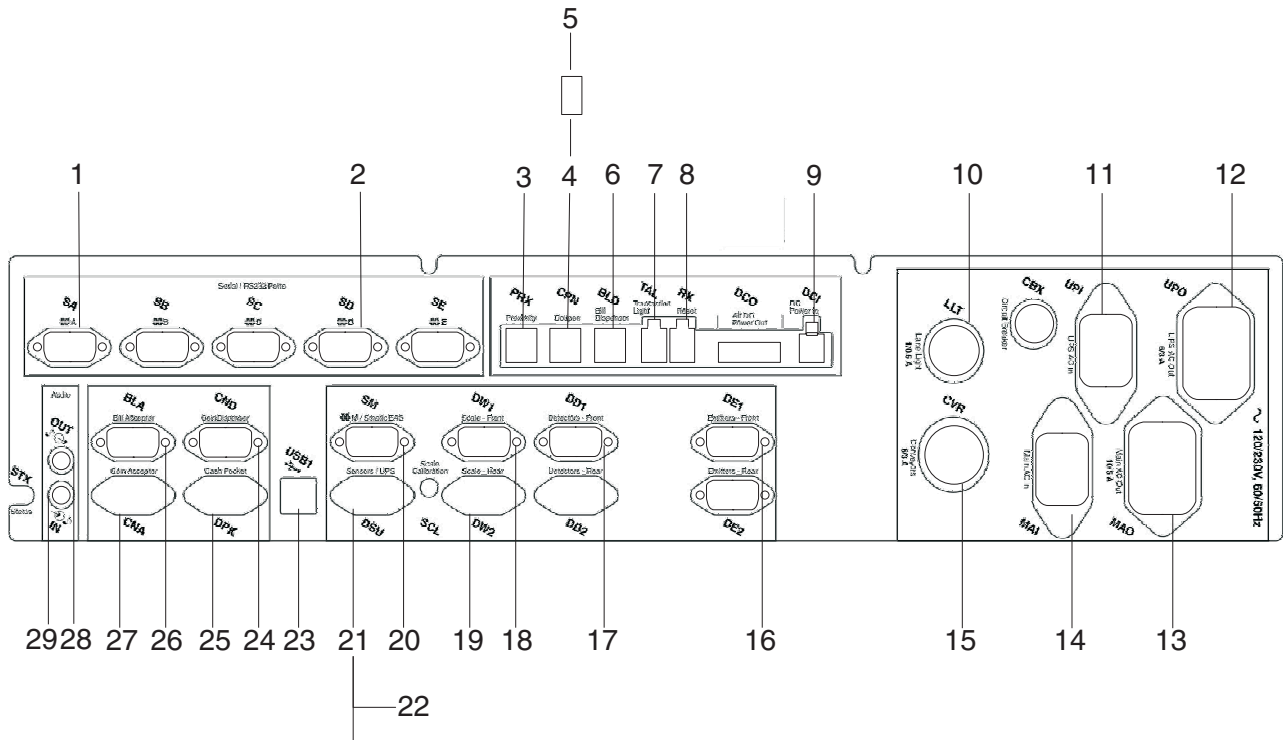

Asm- Index	Part Number	Units	Description
31-			The illustration shown here is for reference only. There is a tag on each cable that contains the part number for that cable. When ordering replacement cables reference the part number on the tag of the failing or broken cable.
-			See "How to Use This Parts Manual" on page v for general parts manual information, including ordering parts. See "Identifying a Right Hand or Left Hand Model" on page v for how to identify left hand and right hand models.
-1	NA	1	Scanner/scale (optional) (SA) (Supplied by the scanner/scale manufacturer)
-2	41D7073	1	RS-232 Security scale (SD) Cable, 6 foot, DB9, male/female
-3	40M9472	1	Proximity sensor to security controller (PRX)
-4	41E1831	1	Coupon detector to security controller (CPN)
-5	41E1830	1	Coupon detector to coupon indicator LED
-6	40M9400	1	Bill dispenser RS232 cable (BLD)
-7	NA	1	Transaction awareness light (TAL) (comes as part of the light assembly)
-8	40M9470	1	Reset button (RX)
-9	41K6368	1	Security controller DC power (DCI) with power supply
-10	NA	1	Lane light (optional) (LLT) (comes as part of the light assembly)
-11	28R3565	1	Power input from uninterruptible power supply cable (UPI)
-12	28R3559	1	Uninterruptible power supply power output to device power strip (UPO) IEC60320 to C14 Adapter
-13	28R3559	1	Main power output (MAO)
-14	28R3589	1	Main power input from power filter box (MAI)
-15	40M9423	1	Capacitor box (CVB)
-16	41D7073	1	To curtain emitter (DE1) Cable, 6 foot, DB9, male/female
-17	41D7073	1	To curtain detector (DD1) Cable, 6 foot, DB9, male/female
-18	41D7073	1	Security scale front load cell (DW1) Cable, 6 foot, DB9, male/female
-19	41D7073	1	Security scale rear load cell (DW2) Cable, 6 foot, DB9, male/female
-20	44D1165	1	Sensormatic control cable
-21	41E1619	1	Splitter cable to uninterruptible power supply and sensors (DSU)
-22	41D7073	1	Cable to uninterruptible power supply from splitter cable
-22	41D9361	1	240V Cable to uninterruptible power supply from splitter cable
-23	41J7731	1	USB to lane PC (USB1)
-24	41K6352	1	Coin dispenser data cable (DB9 on one end, RJ45 on other)
-25	41K6365	1	Cash cup (DPK)
-	44M1643	1	Cash cup detector cable (not shown)
-	41J9835	1	Cash cup emitter cable (not shown)
-26	28R3684	1	Bill acceptor (BLA)
-27	41K6354	1	Coin acceptor cable, US/Canada
-27	41K6359	1	Coin acceptor cable, EMEA/Australia
-28	41K6370	1	Audio out to speaker (OUT)
-29	41K6369	1	Audio to lane PC (IN)
-	41D7072	1	10' Ethernet CAT5 cable
-	41D7075	1	5' Ethernet CAT5 cable
-	41D7073	1	ELO touchscreen Cable, 6 foot, DB9, male/female
-	41J7452	1	Cable harness loop style

Assembly 32: Power Cords

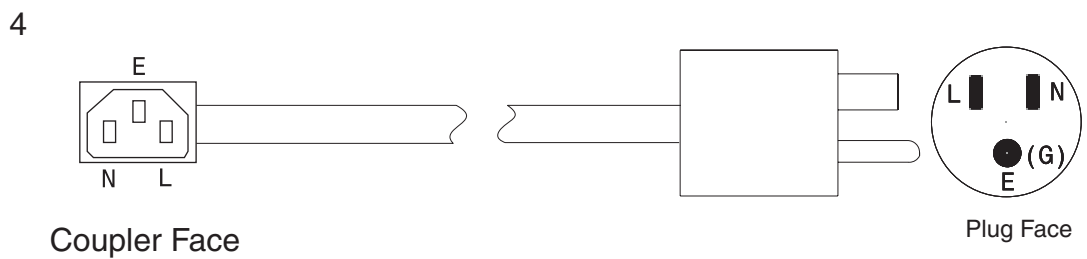
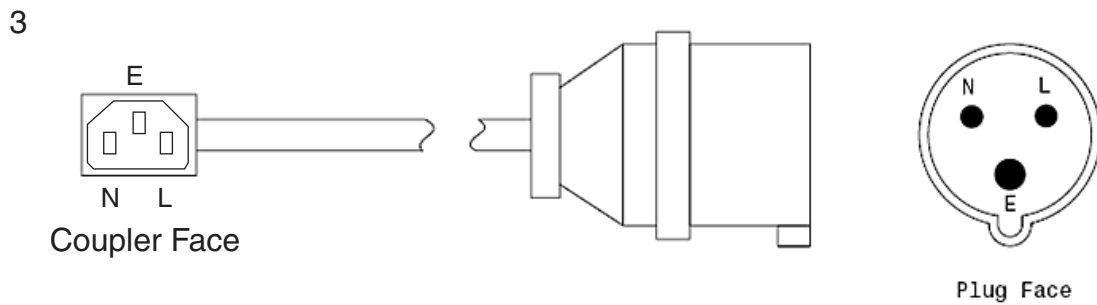
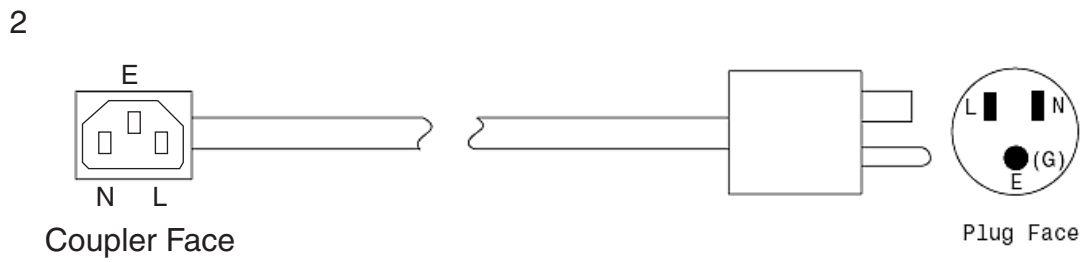
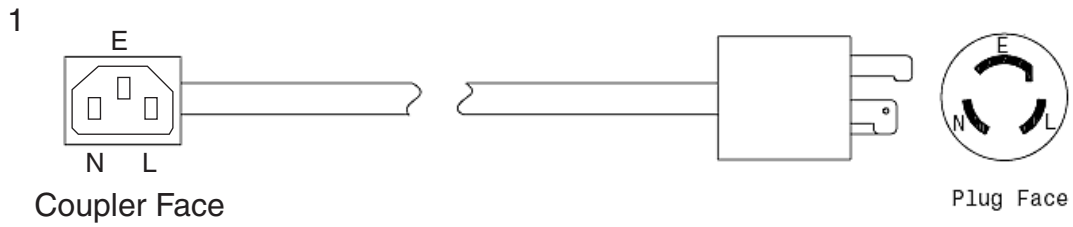

Asm- Index	Part Number	Units	Description
32-1	39M5107	1	4.3m, Right angle power cord, NEMA L5-15P
-2	39M5073	1	4.3m, Nonlock right angle power cord, NEMA 5-15P
-3	39M5177	1	4.3m, Right angle power cord, IEC 309 16A/250V 2P+G
-4	41J8393	1	1.8m, Inline coupler power cord, IEC 320 10A/125V

Chapter 11. Locks and Keys

Assembly 33: Currency Lock with Key	96
Assembly 34: Cabinet Lock with Key	98

Assembly 33: Currency Lock with Key

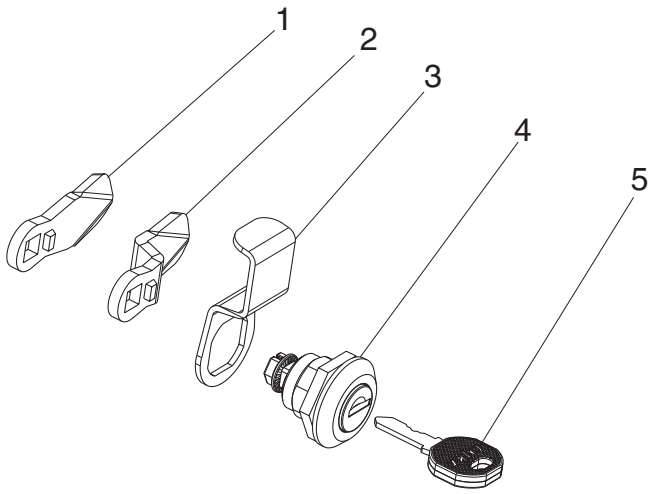

Asm-Index	Part Number	Units	Description
33-1	41K6088	1	Coin lock cam
-2	41K6087	1	Safe lock cam
-3	44D0244	1	Safe door pull
-4	41K6120	1	Currency lock with key, combo #1, Emka key 306
-4	41K6121	1	Currency lock with key, combo #2, Emka key 314
-4	41K6122	1	Currency lock with key, combo #3, Emka key 321
-4	41K6123	1	Currency lock with key, combo #4, Emka key 343
-4	41K6124	1	Currency lock with key, combo #5, Emka key 351
-4	41K6125	1	Currency lock with key, combo #6, Emka key 382
-4	41K6126	1	Currency lock with key, combo #7, Emka key 420
-4	41K6127	1	Currency lock with key, combo #8, Emka key 437
-4	41K6128	1	Currency lock with key, combo #9, Emka key 463
-4	41K6129	1	Currency lock with key, combo #10, Emka key 520
-5	41K6130	1	Currency key, combo #1, Emka key 306
-5	41K6131	1	Currency key, combo #2, Emka key 314
-5	41K6132	1	Currency key, combo #3, Emka key 321
-5	41K6133	1	Currency key, combo #4, Emka key 343
-5	41K6134	1	Currency key, combo #5, Emka key 351
-5	41K6135	1	Currency key, combo #6, Emka key 382
-5	41K6136	1	Currency key, combo #7, Emka key 420
-5	41K6137	1	Currency key, combo #8, Emka key 437
-5	41K6138	1	Currency key, combo #9, Emka key 463
-5	41K6139	1	Currency key, combo #10, Emka key 520

Assembly 34: Cabinet Lock with Key

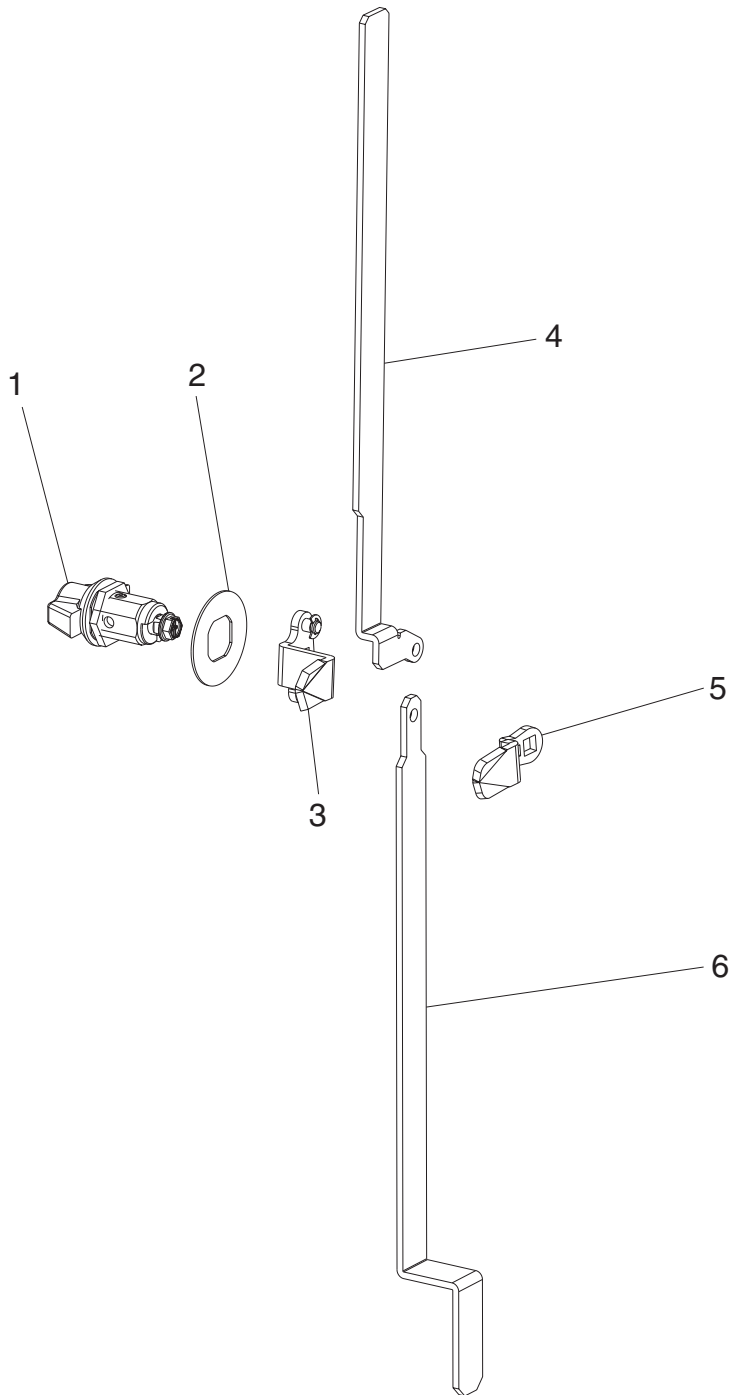

Asm- Index	Part Number	Units	Description
34-1	42K0080	1	Cabinet lock with key, combo #1, Emka key 305
-1	42K0081	1	Cabinet lock with key, combo #2, Emka key 436
-1	42K0082	1	Cabinet lock with key, combo #3, Emka key 448
-1	42K0083	1	Cabinet lock with key, combo #4, Emka key 449
-1	42K0084	1	Cabinet lock with key, combo #5, Emka key 450
-1	42K0085	1	Cabinet lock with key, combo #6, Emka key 471
-1	42K0086	1	Cabinet lock with key, combo #7, Emka key 478
-1	42K0087	1	Cabinet lock with key, combo #8, Emka key 487
-1	42K0088	1	Cabinet lock with key, combo #9, Emka key 502
-1	42K0089	1	Cabinet lock with key, combo #10, Emka key 608
-	42K0090	1	Cabinet key, combo #1, Emka key 305
-	42K0091	1	Cabinet key, combo #2, Emka key 436
-	42K0092	1	Cabinet key, combo #3, Emka key 448
-	42K0093	1	Cabinet key, combo #4, Emka key 449
-	42K0094	1	Cabinet key, combo #5, Emka key 450
-	42K0095	1	Cabinet key, combo #6, Emka key 471
-	42K0096	1	Cabinet key, combo #7, Emka key 478
-	42K0097	1	Cabinet key, combo #8, Emka key 487
-	42K0098	1	Cabinet key, combo #9, Emka key 502
-	42K0099	1	Cabinet key, combo #10, Emka key 608
-2	41K6585	1	Lock indicator
-3	41K6094	1	Lock cam, lower door
-4	41K6105	1	Latch bar, upper RH, lower door
-4	41K6597	1	Latch bar, upper LH, lower door
-5	41K6087	1	Lock cam, upper door
-6	41K6104	1	Latch bar, lower, lower door
-	41K6098	1	Vertical crossbar lock bar, upper door (for doors with a single lock)
-	41K6099	1	Horizontal crossbar lock bar, upper door (for doors with a single lock)
-	41K6100	1	Latching bar, upper door, right hand (for doors with a single lock)

Chapter 12. Field Kits and Tools

Assembly 35: Field Kits and Tools 102

Field kits contain an assortment of screws, washers, nuts, and bolts.

Hardware items such as screws, bolts, nuts, and washers, removed during the disassembly of parts should be retained for use during re-assembly of those parts. Screws, bolts, nuts, and washers can not be ordered separately, they are available as part of a field kit.

Assembly 35: Field Kits and Tools

Asm-Index	Part Number	Units	Description
35-	41D7009	1	4845 Fastener kit This kit contains:
-			2 - #4-40 Hex nuts
-			2 - #6-32 Lock nuts
-			2 - 1/4"-20 Hex nut
-			2 - #6-32 Hex nut
-			2 - #8-32 Nylon lock nuts
-			2 - #10-32 Nylon nuts
-			2 - 1/4"-20 Hex nuts
-			8 - 1/4"-20 Nylon nuts
-			4 - 5/16"-18 Hex nuts
-			2 - 1/4"-20 x 1/2" Phillips head pan screws
-			2 - #10-32 x 3" Phillips head pan screws
-			2 - M3 x 8mm Slotted flat head screws
-			2 - #6-32 x 3/8" Phillips pan screws
-			2 - #10-32 x 5/8" Phillips pan head screws
-			2 - #6-32 x 1/4" Phillips pan head screws
-			2 - #10-32 x 5/8" Phillips pan head screws
-			2 - #6-32 x 1/4" Phillips pan head screws
-			2 - #10-32 x 1/2" Phillips pan head screws
-			2 - #10-32 x 1/4" Cup point set screws
-			2 - #10-32 x 1/2" Phillips sheet metal screws
-			2 - #5/16"-18 x 4" bolts
-			2 - #10-32 x 1/2" Cup point set screws
-			2 - #6-32 x 3/8" Phillips flat head machine screws
-			2 - #8-32 x 1/2" Black Phillips washer head screws
-			2 - #6-32 x 1/4" Flat head screws
-			2 - #8-32 x 5/8" Phillips sheet metal flange head
-			2 - #8-32 x 1/2" Phillips pan head sheet metal screws
-			2 - #8-32 x 3/4" Phillips sheet metal screws
-			2 - #10-32 x 5/8" Phillips pan head screws
-			4 - #10-32 x 1/2" Button head machine screws
-			2 - #10-32 x 1/2" Phillips Pan head screws
-			2 - #10-32 x 3/4" Phillips pan head machine screws
-			2 - 1/4"-28 x 1-1/2" Hex cap screws
-			2 - 1/4"-20 x 3/4" Hex cap screws
-			2 - 1/4"-20 x 5/8" Hex cap screws
-			2 - 1/4"-20 x 1" Phillips flat head screws
-			4 - 1/4"-20 x 1" Hex cap screws
-			2 - 1/4"-20 x 2-1/4" Hex cap screws
-			2 - 1/4"-20 X 1-1/4" Hex cap screws
-			2 - Fully threaded rod
-			2 - 3/8"-16 x 1" Hex cap screw
-			2 - 3/8" Lock nuts
-			2 - #4-40 x 5/8" Phillips pan head screws
-			4 - Hinged black screw cover
-			4 - 1/4"-20 x 3/4" Phillips pan head screws
-			4 - #10-32 x 1/4" Phillips pan head machine screws
-			2 - #10-24 x 1/4" Pan head machine screws
-			2 - M4 x 8mm screws
-			2 - M5 x 6mm Phillips pan head machine screws
-			2 - #6-32 x 1/2" Self-tapping screws
-			2 - #6 External star washers
-			2 - #6 Split lock washers

Asm-Index	Part Number	Units	Description
-			2 - #4 Split lock washers
-			2 - 1/4" x 1/2" Hex cap screws
-			4 - 5/16" Flat washers
-			2 - #10 Flat washers
-			4 - 1/4" Flat washers
-			4 - 1/4" Split lock washers
-			2 - 1/4" External star washers
-			2 - 3/8" Split lock washers
-			4 - 1/4" Flat washers
-			2 - 1/4"-20 x 2-1/2" Hex screws
-			4 - #10-24 Nylon lock nuts
-	44D0412	1	Washer/clip kit
-	44D0533	1	UNC screw kit
-	44D0534	1	Metric screw kit
-	44M2154	1	Cash module lower door field adjustment kit, right hand
-	44M2155	1	Cash module lower door field adjustment kit, left hand
-	44D1606	1	Sensormatic field installation kit
-	41D9631	1	Velcro tape
-	44D1776	1	Version 3.00 Ghost software kit
-	41D9350	1	US coin acceptor programming module
-	41D9351	1	Canadian coin acceptor programming module
-	41D9352	1	UK coin acceptor programming module
-	41D9353	1	Euro coin acceptor programming module
-	41D9354	1	Australian coin acceptor programming module
-	41D9355	1	US penniless coin acceptor programming module
-	41D7101	1	Bill dispenser fastener kit (fasteners, screws, and retainers)
-	41K6284	1	Bill dispenser screwdriver kit

Appendix A. Cabinet Parts and Sensors

Assembly 36: Core Module Cabinet FRUs	106
Assembly 37: Security Conveyor and Transport Conveyor Cabinet	110
Assembly 38: Models 152, 602, and 612 Bagging Cabinet	112
Assembly 39: Models 153, 603, and 613 Bagging Cabinet	114
Assembly 40: Model N54 Bagging Cabinet	116
Assembly 41: Models 171, 800, and 810 Bagging Cabinet	118
Assembly 42: Models 171, 800, and 810 Bumpers, Order Separators, Soft Goods Shelf	120
Assembly 43: Sensors, Emitters, and Detectors	122

This appendix contains the locations and descriptions of the cabinet parts. Cabinet parts can be ordered by description from the IBM Self Checkout Solution service center. You must have the IBM Self Checkout Solution model number, cabinet part description, customer name, color, and whether the machine is a left hand or right hand model.

Assembly 36: Core Module Cabinet FRUs

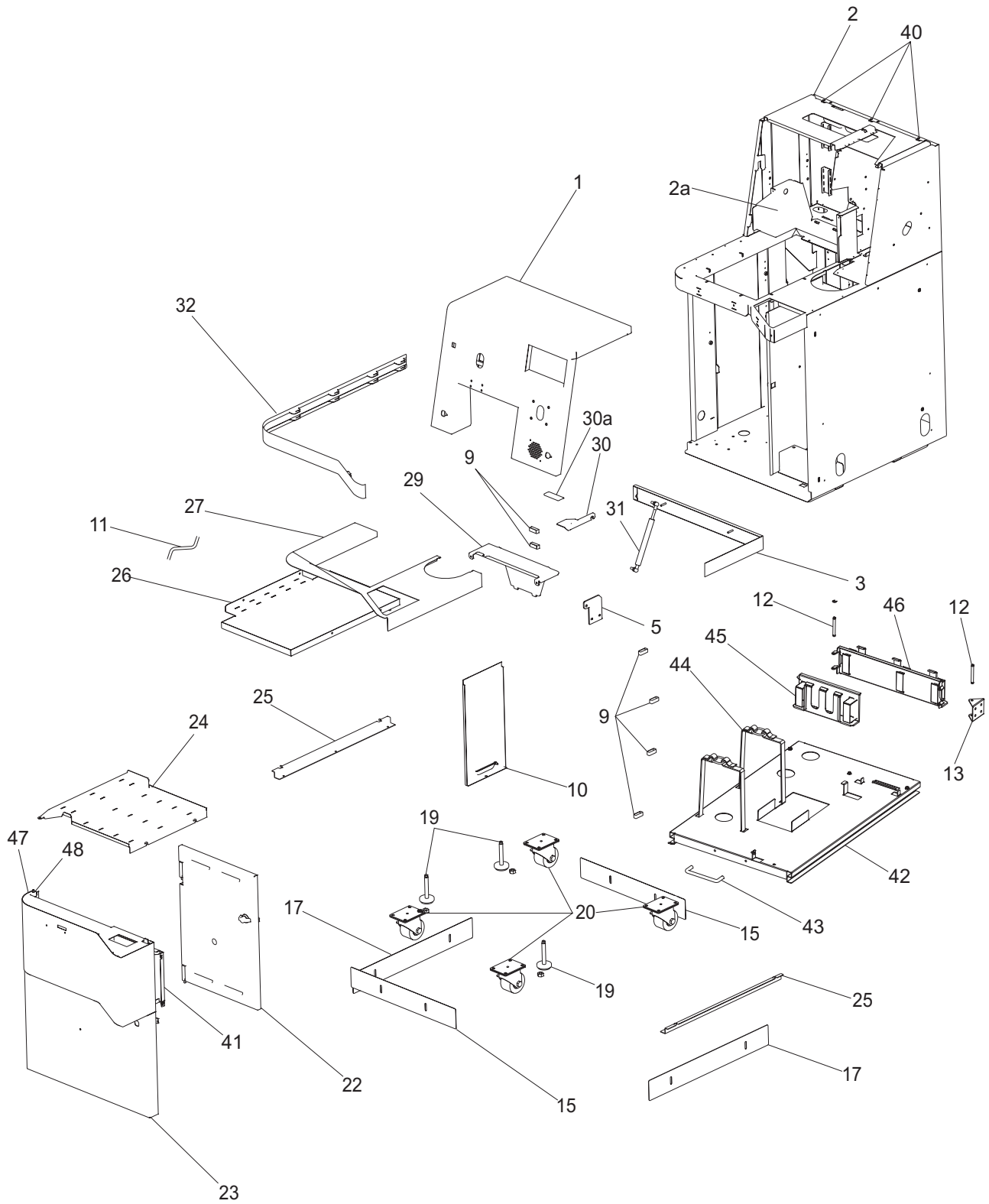

Asm- Index	Part Number	Units	Description
36-			Be sure to specify whether you are ordering replacement parts for a left hand or a right hand model. See "How to Use This Parts Manual" on page v for general parts manual information, including ordering parts. See "Identifying a Right Hand or Left Hand Model" on page v for how to identify left hand and right hand models.
-1			Upper door assembly (No part number assigned, custom color part)
-2			Cabinet Weldment (No part number assigned, custom color part)
-3	42K0056	1	Rear bumper
-5	42K0068	1	Gas spring stiffener plate
-9	41K6103	1	Cable retainer, hook and loop
-10			Exterior access panel (No part number assigned, custom color part)
-	41K6165	1	Access panel thumbscrew/retainer (not shown)
-11	41K6164	1	Drip pan tubing
-12	41K6600	1	Cable, basket shaft
-13	41K6148	1	Cable basket bracket
-15	41K6150	1	Front/rear kick plate
-17	41K6149	1	Left/right kick plate
-19	41D7344	1	Leveler (replaces 39Y0601)
-20	12R9478	1	Caster, swivel
-22	41K6167	1	PC access door assembly, right hand
-22	41K6168	1	PC access door assembly, left hand
-23			Lower door assembly, cash module (No part number assigned, custom color part)
-24	41K6154	1	Accessory shelf, right hand
-24	41K6155	1	Accessory shelf, left hand
-25	41K6156	1	PC/Uninterruptible power supply shelf bracket
-26	41K6162	1	Drip pan, right hand
-26	41K6163	1	Drip pan, left hand
-27			Upper countertop assembly (see "Assembly 18: Countertop" on page 44 for a complete listing of available countertops)
-29	42K0057	1	Scanner hood
-30	41K6151	1	Upper door cover stop, right hand
-30	41K6152	1	Upper door stop cover, left hand
-30A	41K6153	1	Upper door cover stop nut
-31	42K0051	1	Gas spring
-32	41K6157	1	Bumper, front
-	41K6159	1	Bumper gasket (not shown)
-40	41K6102	1	Upper door hinge (includes fasteners)
-41	41K6106	1	Lower door, coupon box assembly
-	41K6108	1	Lower door keyboard retaining bracket (not shown)
-42	41K6140	1	PC/uninterruptible power supply shelf, right hand
-42	41K6141	1	PC/uninterruptible power supply shelf, left hand
-43	41K6083	1	Drawer pull
-44	41K6142	1	Velcro strap for uninterruptible power supply
-45	41K6144	1	Cable basket, short, right hand
-45	41K6146	1	Cable basket, short, left hand
-46	41K6143	1	Cable basket, long, right hand
-46	41K6145	1	Cable basket, long, left hand
-47	44M1961		Lower door welded hinge pin, right hand
-47	44M1959		Lower door welded hinge pin, left hand
-48	41J6659	1	Lower door hinge spacer plate (not shown)
-	41K6595	1	Door stop, lower (not shown)
-	41D8382	1	Adjuster, lower door, RH (not shown)
-	41D8383	1	Adjuster, lower door, LH (not shown)
-	41K6572	1	Upper door cable cover (not shown)

Asm- Index	Part Number	Units	Description
-	42K0050	1	Spacer for scanner leveler (not shown)
-	41K6147	1	Velcro strap for cable basket (not shown)
-		1	Filler plate, lane light mount opening (used if lane light mount is not used, not shown) (no part number given, custom color part)

Updated October 16, 2007

Assembly 37: Security Conveyor and Transport Conveyor Cabinet

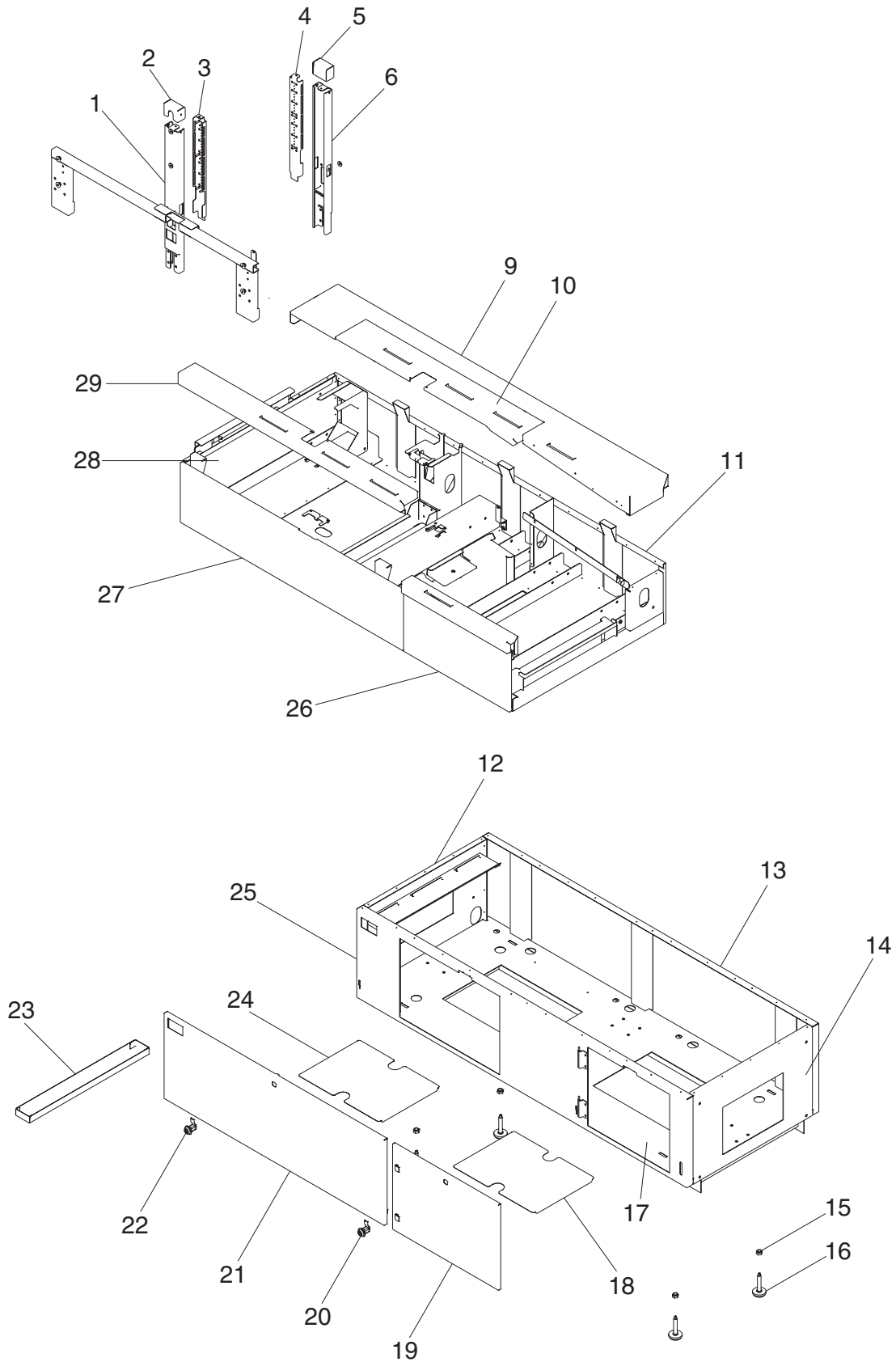

Asm-Index	Part Number	Units	Description
37-			Be sure to specify whether you are ordering replacement parts for a left hand or a right hand model. See "How to Use This Parts Manual" on page v for general parts manual information, including ordering parts. See "Identifying a Right Hand or Left Hand Model" on page v for how to identify left hand and right hand models.
-1			Tower (a single welded assembly, the front curtain support). See 24-30 on page 62.
-2			Tower cap. See 24-32 on page 62.
-3			Curtain detector assembly. See 24-32 on page 62 for detector/emitter FRU number.
-4			Curtain emitter assembly. See 24-32 on page 62 for detector/emitter FRU number.
-5			Tower cap. See 24-32 on page 62.
-6			Tower, rear curtain support. See 24-33 on page 62.
-7			Channel support
-8			Support bracket
-9			Access door assembly
-10			Wide rail
-11			Upper cabinet console
-12			Front bulkhead
-13			Lower panel
-14			Rear bulkhead
-15			Leveler lock nut
-16			Leveler
-17			Lower cabinet
-18			Cover plate
-19			Transport section door (no FRU number given, custom color part)
-20	41K6382	1	Hex key cam lock
-21			Security module lower access door (no FRU number given, custom color part)
-22	41K6382		Hex key cam lock
-23			Trash tray
-24			Cover plate
-25			Lower door panel
-26			Transport conveyor access panel (no FRU number given, custom color part)
-27			Security conveyor access panel (no FRU number given, custom color part)
-28			Bulkhead assembly
-29			Narrow rail (shopper side)

Assembly 38: Models 152, 602, and 612 Bagging Cabinet

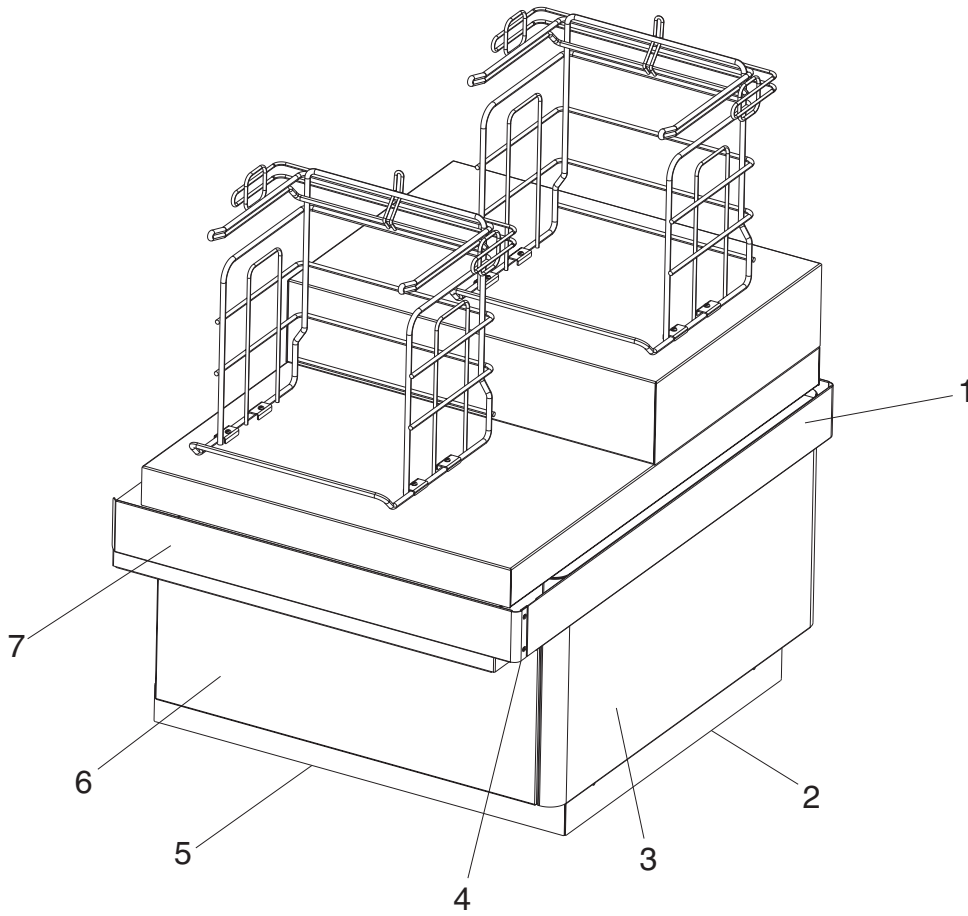

Asm- Index	Part Number	Units	Description
38-			Be sure to specify whether you are ordering replacement parts for a left hand or a right hand model. See "How to Use This Parts Manual" on page v for general parts manual information, including ordering parts. See "Identifying a Right Hand or Left Hand Model" on page v for how to identify left hand and right hand models.
-1	44D1363	1	Side bumper assembly
-2			Side kickplate
-3		1	Side access cover (no FRU number given, custom color part)
-4	44D1151	2	Corner bumper connector bracket (one on each side)
-5	44D0859	2	Front/rear kickplate
-6		2	Front/back cover (no FRU number given, custom color part)
-7	44D1365	1	Front bumper assembly
-	44D1366	1	Rear bumper assembly (not shown)
-	41K6382	1	Hex key cam lock
 			1 Lane light mounting clamp (not shown, used when lane light assembly is mounted to the Models 152, 602, and 612 bagging module). See 20- on page 49 for FRU number.
 			1 Lane light mounting strap (not shown, used when lane light assembly is mounted to the Models 152, 602, and 612 bagging module). See 20- on page 49 for FRU number.

Assembly 39: Models 153, 603, and 613 Bagging Cabinet

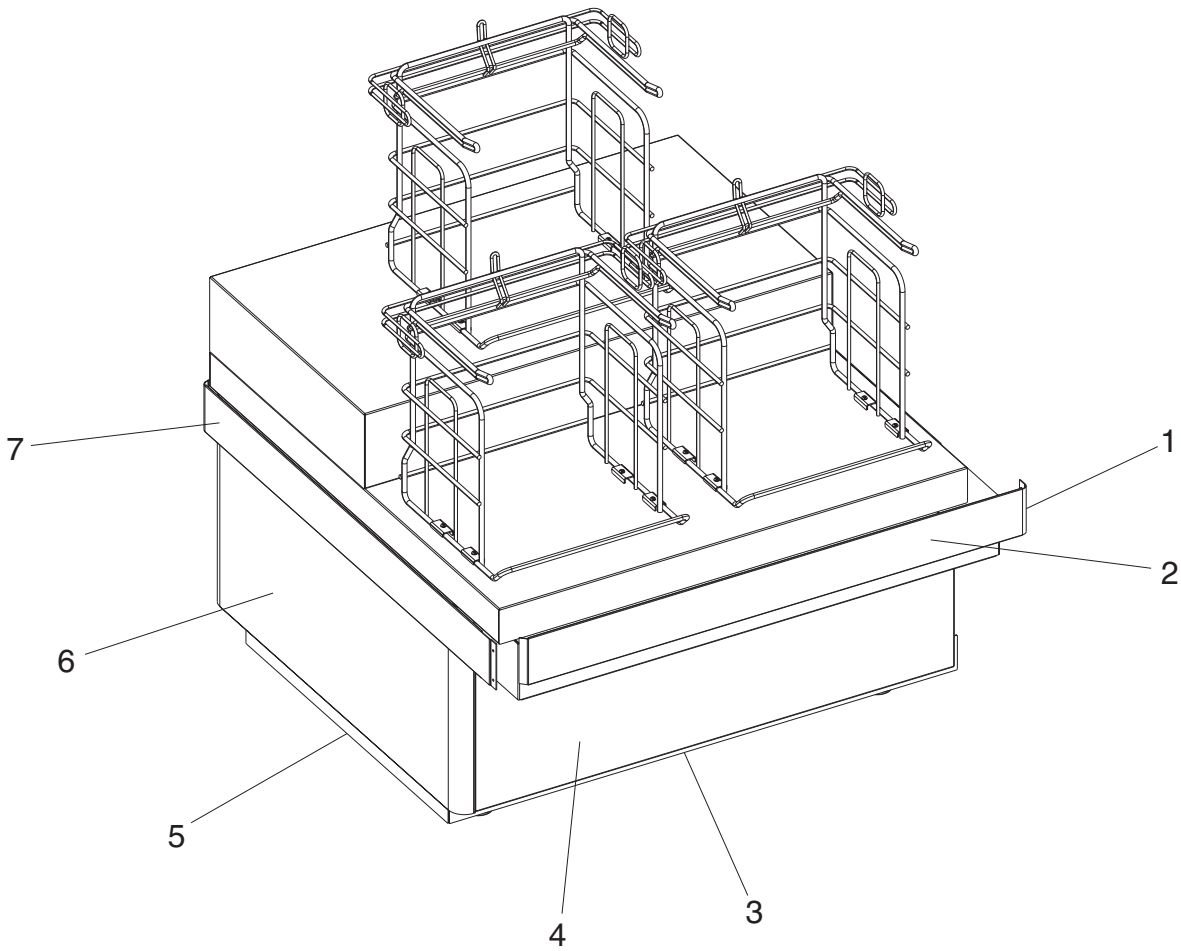

Asm- Index	Part Number	Units	Description
39-			Be sure to specify whether you are ordering replacement parts for a left hand or a right hand model. See "How to Use This Parts Manual" on page v for general parts manual information, including ordering parts. See "Identifying a Right Hand or Left Hand Model" on page v for how to identify left hand and right hand models.
-1	44D1151	2	Corner bumper connector bracket (one on each side)
-2	44D1364	2	Front/rear bumper assembly
-3	44D0860	2	Front/rear kickplate
-4		1	Front access cover (no FRU number given, custom color part)
-5		1	Side kickplate
-6		2	Side/back cover (no FRU number given, custom color part)
-7	44D1363	1	Side bumper assembly

Assembly 40: Model N54 Bagging Cabinet

Asm- Index	Part Number	Units	Description
40-			Be sure to specify whether you are ordering replacement parts for a left hand or a right hand model. See "How to Use This Parts Manual" on page v for general parts manual information, including ordering parts. See "Identifying a Right Hand or Left Hand Model" on page v for how to identify left hand and right hand models.
-			Front/rear bumper assembly
-	41J9751	1	Front/rear kickplate
-	41J9752	1	Side kickplate
-	41J9750	1	Side bumper assembly

Assembly 41: Models 171, 800, and 810 Bagging Cabinet

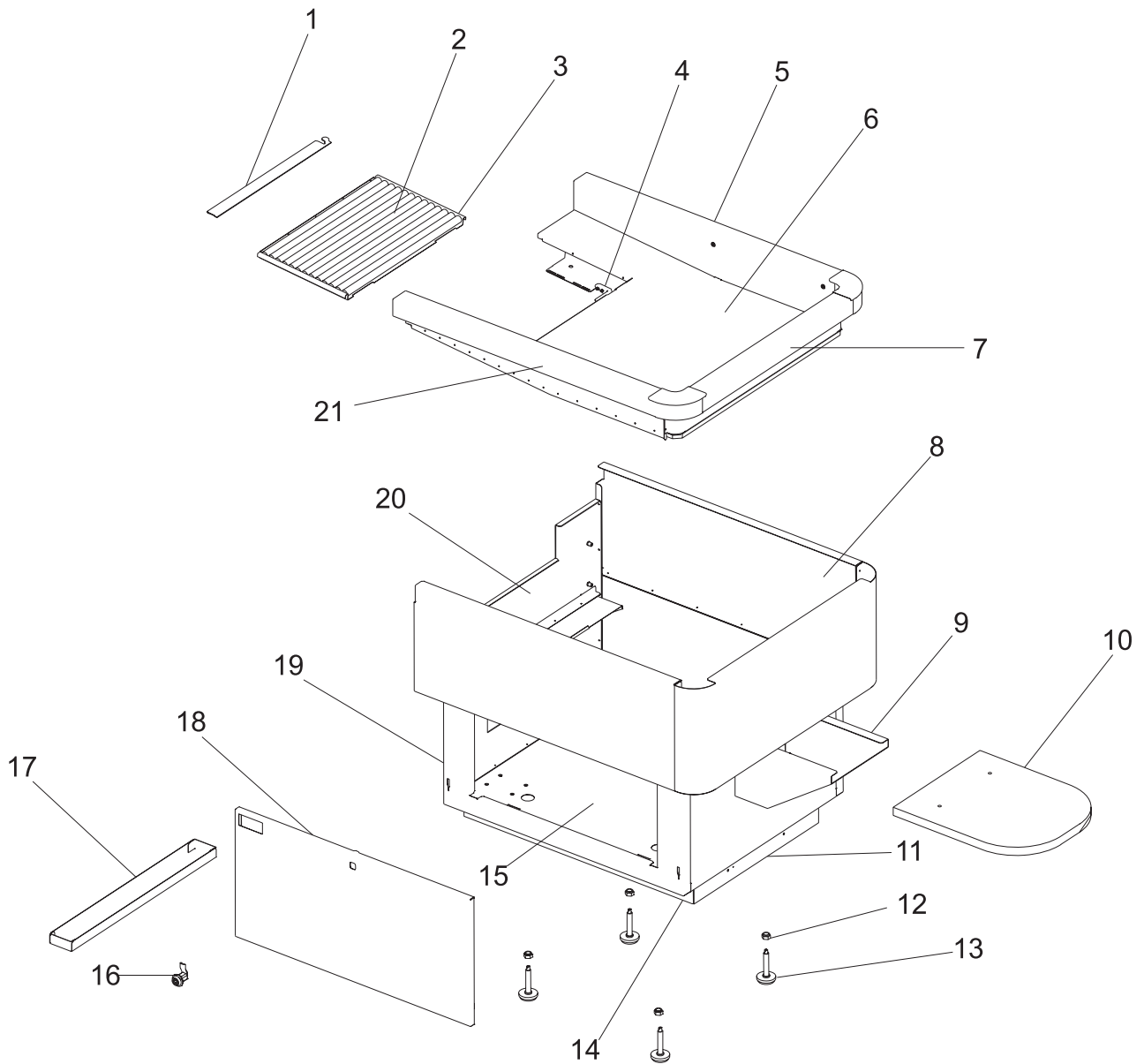

Asm-Index	Part Number	Units	Description
41-			Be sure to specify whether you are ordering replacement parts for a left hand or a right hand model. See "How to Use This Parts Manual" on page v for general parts manual information, including ordering parts. See "Identifying a Right Hand or Left Hand Model" on page v for how to identify left hand and right hand models.
-1	44D0264	1	Rear (bagging) transition plate, for right hand, standard lane with 19 inch belt
-	44D0266	1	Rear (bagging) transition plate, for right hand, wide lane with 25 inch belt
-	44D0265	1	Rear (bagging) transition plate, for left hand, standard lane with 19 inch belt
-	41K6387	1	Roller assembly for right hand, standard lane with 19 inch belt (includes rollers, frame, bracket, rear transition plate, cover plate, screw, wing nut)
-	44D0274	1	Roller assembly for left hand, standard lane with 19 inch belt (includes rollers, frame, bracket, rear transition plate, cover plate, screw, wing nut)
-2	41K6388	1	Bagger roller for standard lane with 19 inch belt
-	44M1749	1	Bagger roller for wide lane with 25 inch belt
-	44M2123	1	M5 nylon wing nut (not shown)
-3	44M1995	1	Roller frame bracket
-	44M1992	1	Roller frame cover plate (not shown, located under the rollers)
-4	41K6391	1	Hinge bracket
-5			Side rail assembly
-6			Desk pan
-7			Desk pan holder
-8			Cabinet upper console
-9	41K6386	1	Bagging shelf support
-10	41K6385	1	Bagging shelf
-	41D8119	1	Bagging shelf (for 90 degree angled bag rack, right hand or left hand)
-11	41K6384	1	End kickplate for 19, 28, 48, and 66 inch bagging cabinets
-12			Nut leveler adjusting lock nut
-13			Leveler
-14	44D0854	1	Side kickplate for 19 inch bagging cabinet
-	44D0855	1	Side kickplate for 28 inch bagging cabinet
-	44D0856	1	Side kickplate for 48 inch bagging cabinet
-	44D0857	1	Side kickplate for 66 inch bagging cabinet
-15			Frame, Weldment
-16			Hex key cam lock
-17			Trash tray
-18			Cabinet door
-19			Panel, lower door
-20			Bulkhead assembly
-21			Side rail

Assembly 42: Models 171, 800, and 810 Bumpers, Order Separators, Soft Goods Shelf

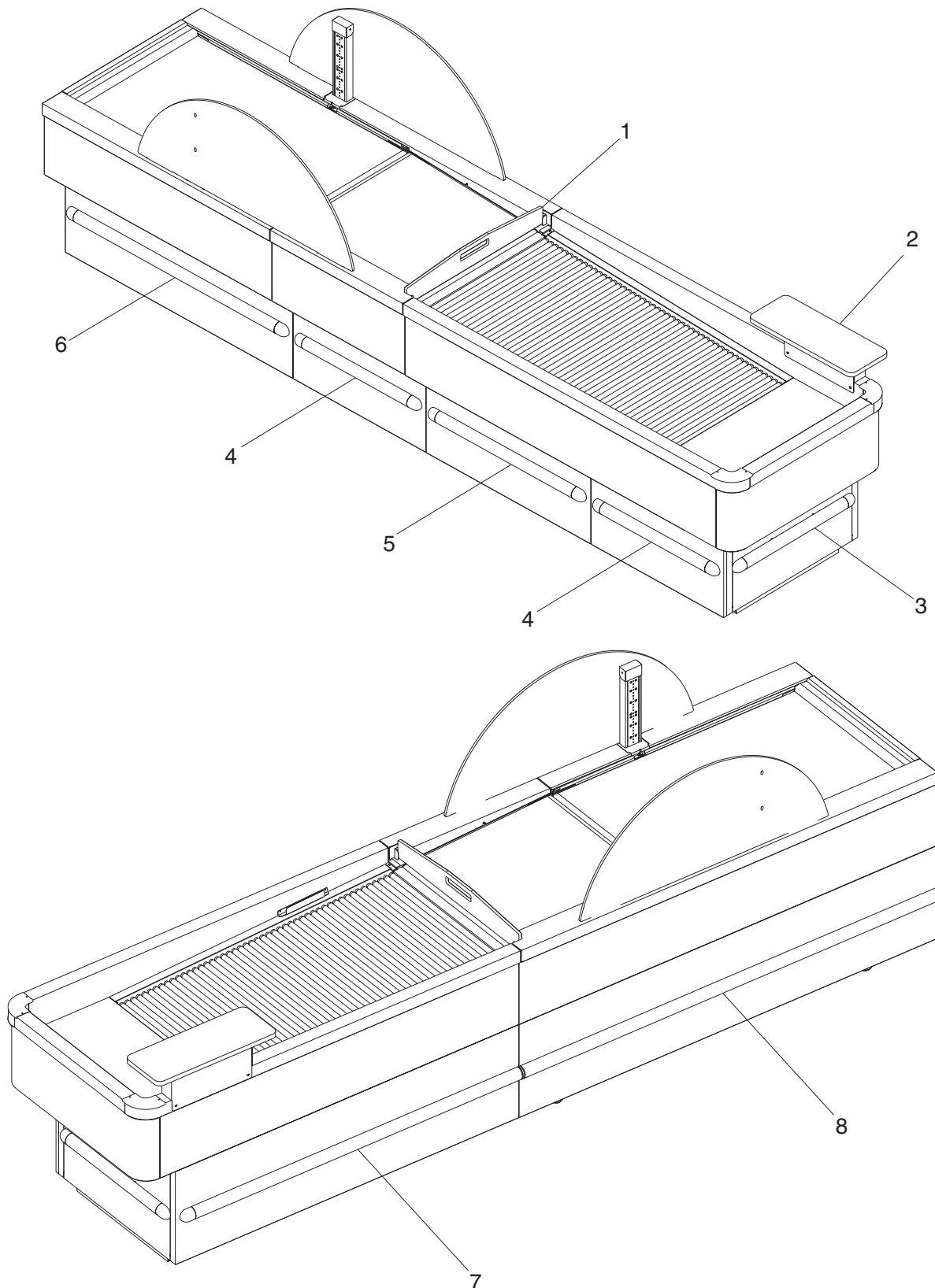

Asm- Index	Part Number	Units	Description
42-			Be sure to specify whether you are ordering replacement parts for a left hand or a right hand model. See "How to Use This Parts Manual" on page v for general parts manual information, including ordering parts. See "Identifying a Right Hand or Left Hand Model" on page v for how to identify left hand and right hand models.
-1	41J7126	1	25 inch order separator
-1	41J7127	1	19 inch order separator
-2	41K6379	1	Bagger soft good shelf
-	41D8764	1	Bumper, stock gray, 140mm (not shown, used on core module)
-	41D8766	1	Bumper, stock gray, 150mm (not shown, used on bagging module)
-	41D8768	1	Bumper, stock gray, 280mm (not shown, used on core module)
-	41D8770	1	Bumper, stock gray, 470mm (not shown, used on core module)
-3	41D8772	1	Bumper, stock gray, 540mm
-4	41D8772	1	Bumper, stock gray, 540mm
-5	41D8774	1	Bumper, stock gray, 700mm
-6	41D8776	1	Bumper, stock gray, 1030mm
-7	41D8778	1	Bumper, stock gray, 1450mm
-8	41D8780	1	Bumper, stock gray, 1840mm
-	44D0852	1	Side kickplate, 19 in. security module
-	44D0853	1	Side kickplate, 25 in. security module

Assembly 43: Sensors, Emitters, and Detectors

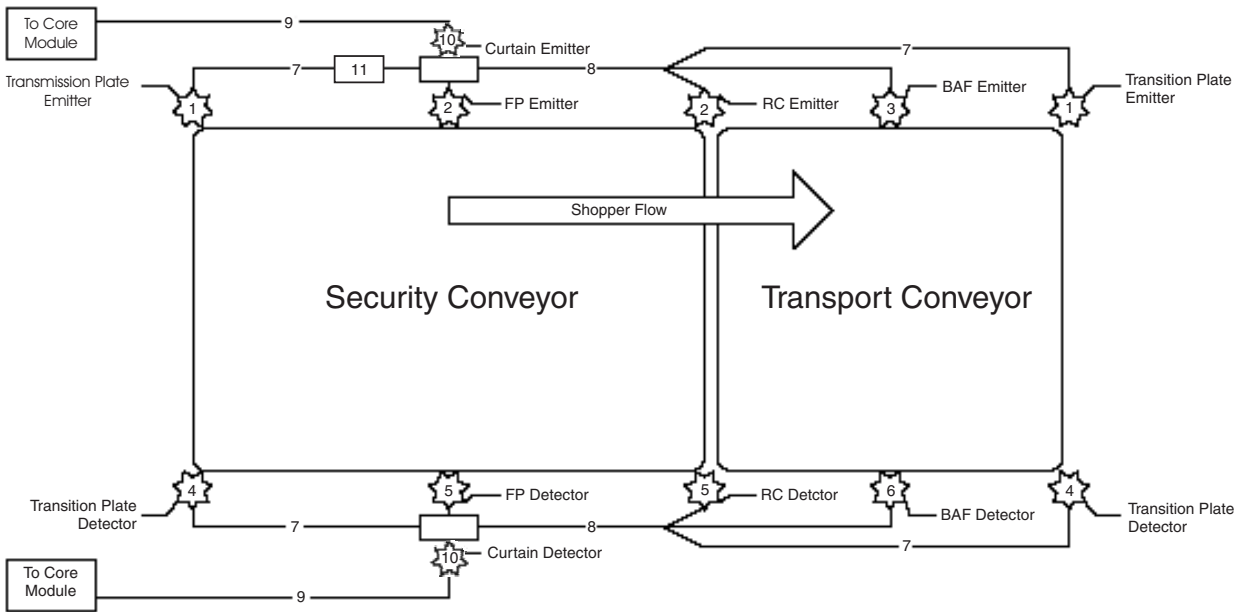

Asm- Index	Part Number	Units	Description
43-			Be sure to specify whether you are ordering replacement parts for a left hand or a right hand model. See "How to Use This Parts Manual" on page v for general parts manual information, including ordering parts. See "Identifying a Right Hand or Left Hand Model" on page v for how to identify left hand and right hand models.
-1			Transition plate emitter. See 25- on page 65 for FRU number.
-2			Flat pack sensor emitter and also exit sensor emitter. See 24-11 on page 61 and 24-12 on page 61 for FRU number.
-3			Bagging area full emitter sensor assembly. See 25-15 on page 65 for FRU number.
-4			Transition plate detector. See 25- on page 65 for FRU number.
-5			Flat pack sensor emitter and also exit sensor emitter. See 24-26 on page 62 and 24-12 on page 61 for FRU number.
-6			Bagging area full detector sensor. See 25-21 on page 65 for FRU number.
-7			Transition plate extension cable. See 24- on page 62 for FRU number.
-8			Sensor extension cable. See 24- on page 62 for FRU number.
-9			DB9 cable curtain emitter/detector extension cable. See 31-16 on page 91 for FRU number.
-10			Curtain detector/emitter sensor assembly. See 24-32 on page 62 for FRU number.
-11	44M1624	1	Ferrite core (on transition plate extension cable)

Appendix B. Notices

This information was developed for products and services offered in the U.S.A.

IBM may not offer the products, services, or features discussed in this document in other countries. Consult your local IBM representative for information on the products and services currently available in your area. Any reference to an IBM product, program, or service is not intended to state or imply that only that IBM product, program, or service may be used. Any functionally equivalent product, program, or service that does not infringe any IBM intellectual property right may be used instead. However, it is the user's responsibility to evaluate and verify the operation of any non-IBM product, program, or service.

IBM may have patents or pending patent applications covering the subject matter in this document. The furnishing of this document does not give you any license to these patents. You can send license inquiries, in writing, to:

IBM Director of Licensing
IBM Corporation
North Castle Drive
Armonk, NY 10504-1785
U.S.A.

For license inquiries regarding double-byte character set (DBCS) information, contact the IBM Intellectual Property Department in your country or send inquiries, in writing, to:

IBM World Trade Asia Corporation
Licensing
2-31 Roppongi 3-chome, Minato-ku
Tokyo 106, Japan

The following paragraph does not apply to the United Kingdom or any other country where such provisions are inconsistent with local law: INTERNATIONAL BUSINESS MACHINES CORPORATION PROVIDES THIS PUBLICATION "AS IS" WITHOUT WARRANTY OF ANY KIND, EITHER EXPRESS OR IMPLIED, INCLUDING, BUT NOT LIMITED TO, THE IMPLIED WARRANTIES OF NON-INFRINGEMENT, MERCHANTABILITY, OR FITNESS FOR A PARTICULAR PURPOSE. Some states do not allow disclaimer of express or implied warranties in certain transactions, therefore, this statement may not apply to you.

This information could include technical inaccuracies or typographical errors. Changes are periodically made to the information herein; these changes will be incorporated in new editions of the publication. IBM may make improvements and/or changes in the product(s) and/or program(s) described in this publication at any time without notice.

IBM may use or distribute any of the information you supply in any way it believes appropriate without incurring any obligation to you.

Any references in this information to non-IBM Web sites are provided for convenience only and do not in any manner serve as an endorsement of those Web sites. The materials at those Web sites are not part of the materials for this IBM product and use of those Web sites is at your own risk.

Information concerning non-IBM products was obtained from the suppliers of those products, their published announcements or other publicly available sources. IBM has not tested those products and cannot confirm the accuracy of performance, compatibility or any other claims related to non-IBM products. Questions on the capabilities of non-IBM products should be addressed to the suppliers of those products.

This information is for planning purposes only. The information herein is subject to change before the products described become available.

Electronic emission notices

Federal Communications Commission (FCC) statement

This equipment has been tested and found to comply with the limits for a Class A digital device, pursuant to Part 15 of the FCC Rules. These limits are designed to provide reasonable protection against harmful interference when the equipment is operated in a commercial environment. This equipment generates, uses, and can radiate radio frequency energy and, if not installed and used in accordance with the instruction manual, may cause harmful interference to radio communications. Operation of this equipment in a residential area is likely to cause harmful interference, in which case the user will be required to correct the interference at his own expense.

Properly shielded and grounded cables and connectors must be used in order to meet FCC emission limits. IBM is not responsible for any radio or television interference caused by using other than recommended cables and connectors or by unauthorized changes or modifications to this equipment. Unauthorized changes or modifications could void the user's authority to operate the equipment.

This device complies with part 15 of the FCC Rules. Operation is subject to the following two conditions:

1. This device may not cause harmful interference, and
2. This device must accept any interference received, including interference that may cause undesired operation.

European Union EMC Directive conformance statement

This product is in conformity with the protection requirements of EU Council Directive 2004/108/EC on the approximation of the laws of the Member States relating to electromagnetic compatibility. IBM cannot accept responsibility for any failure to satisfy the protection requirements resulting from a non-recommended modification of the product, including the fitting of non-IBM option cards.

This product has been tested and found to comply with the limits for Class A Information Technology Equipment according to CISPR 22/European Standard EN 55022. The limits for Class A equipment were derived for commercial and industrial environments to provide reasonable protection against interference with licensed communication equipment.

Attention: This is a Class A product. In a domestic environment this product may cause radio interference in which case the user may be required to take adequate measures.

European Community contact:

IBM Technical Regulations
Pascalstr. 100, Stuttgart, Germany 70569
Telephone: 0049 (0)711 785 1176
Fax: 0049 785 1283
E-mail: tjahn@de.ibm.com

Industry Canada Class A Emission Compliance statement

This Class A digital apparatus complies with Canadian ICES-003.

Avis de conformité aux normes d'Industrie Canada

Cet appareil numérique de la classe A est conforme à la norme NMB-003 du Canada.

Germany

Zulassungsbescheinigung laut dem Deutschen Gesetz über die elektromagnetische Verträglichkeit von Geräten (EMVG) vom 30. August 1995 (bzw. der EMC EG Richtlinie 89/336).

Dieses Gerät ist berechtigt in Übereinstimmung mit dem Deutschen EMVG das EG-Konformitätszeichen - CE - zu führen.

Verantwortlich für die Konformitätserklärung nach Paragraph 5 des EMVG ist die IBM Deutschland Informationssysteme GmbH, 70548 Stuttgart

Informationen in Hinsicht EMVG Paragraph 3 Abs. (2) 2:

Das Gerät erfüllt die Schutzanforderungen nach EN 50082-1 und EN 55022 Klasse A.
--

EN 55022 Klasse A Geräte müssen mit folgendem Warnhinweis versehen werden:

"Warnung: dies ist eine Einrichtung der Klasse A. Diese Einrichtung kann im Wohnbereich Funkstörungen verursachen; in diesem Fall kann vom Betreiber verlangt werden, angemessene Maßnahmen durchzuführen und dafür aufzukommen."

EN 50082-1 Hinweis:

"Wird dieses Gerät in einer industriellen Umgebung betrieben (wie in EN 50082-2 festgelegt), dann kann es dabei eventuell gestört werden. In solch einem Fall ist der Abstand bzw. die Abschirmung zu der industriellen Störquelle zu vergrößern."

Anmerkung:

Um die Einhaltung des EMVG sicherzustellen sind die Geräte, wie in den IBM Handbüchern angegeben, zu installieren und zu betreiben.

Australia and New Zealand

Attention: This is a Class A product. In a domestic environment this product may cause radio interference, in which case the user may be required to take adequate measures.

Japanese power line harmonics compliance statement

高調波ガイドライン適合品

高調波ガイドライン適合品

Japanese Voluntary Control Council for Interference (VCCI) statement

Attention: This product is a Class A Information Technology Equipment and conforms to the standards set by the Voluntary Control Council for Interference by Technology Equipment (VCCI). In a domestic environment this product may cause radio interference in which case the user may be required to take adequate measures.

この装置は、情報処理装置等電波障害自主規制協議会（VCCI）の基準に基づくクラスA情報技術装置です。この装置を家庭環境で使用すると電波妨害を引き起こすことがあります。この場合には使用者が適切な対策を講ずるよう要求されることがあります。

Cable ferrite requirement

All cable ferrites are required to suppress radiated EMI emissions and must not be removed.

Electrostatic Discharge (ESD)

Attention: ESD damage can occur when there is a difference in charge between the part, the product, and the service person. No damage will occur if the service person and the part being installed are at the same charge level.

ESD Damage Prevention

Anytime a service action involves physical contact with logic cards, modules, back-panel pins, or other ESD sensitive (ESDS) parts, the service person must be connected to an ESD common ground point on the product through the ESD wrist strap and cord.

The ESD ground clip can be attached to any frame ground, ground braid, green wire ground, or the round ground prong on the AC power plug. Coax or connector outside shells can also be used.

Handling Removed Cards

Logic cards removed from a product should be placed in ESD protective containers. No other object should be allowed inside the ESD container with the logic card. Attach tags or reports that must accompany the card to the outside of the container.

Product Recycling and disposal

This unit must be recycled or discarded according to applicable local and national regulations. IBM encourages owners of information technology (IT) equipment to responsibly recycle their equipment when it is no longer needed. IBM offers a variety of product return programs and services in several countries to assist equipment owners in recycling their IT products. Information on IBM product recycling offerings can be found on IBM's Internet site at <http://www.ibm.com/ibm/environment/products/prp.shtml>.

Español:

Esta unidad debe reciclarse o desecharse de acuerdo con lo establecido en la normativa nacional o local aplicable. IBM recomienda a los propietarios de equipos de tecnología de la información (TI) que reciclen responsablemente sus equipos cuando éstos ya no les sean útiles. IBM dispone de una serie de programas y servicios de devolución de productos en varios países, a fin de ayudar a los

propietarios de equipos a reciclar sus productos de TI. Se puede encontrar información sobre las ofertas de reciclado de productos de IBM en el sitio web de IBM <http://www.ibm.com/ibm/environment/products/prp.shtml>.



Notice: This mark applies only to countries within the European Union (EU) and Norway.

Appliances are labeled in accordance with European Directive 2002/96/EC concerning waste electrical and electronic equipment (WEEE). The Directive determines the framework for the return and recycling of used appliances as applicable throughout the European Union. This label is applied to various products to indicate that the product is not to be thrown away, but rather reclaimed upon end of life per this Directive.

In accordance with the European WEEE Directive, electrical and electronic equipment (EEE) is to be collected separately and to be reused, recycled, or recovered at end of life. Users of EEE with the WEEE marking per Annex IV of the WEEE Directive, as shown above, must not dispose of end of life EEE as unsorted municipal waste, but use the collection framework available to customers for the return, recycling, and recovery of WEEE. Customer participation is important to minimize any potential effects of EEE on the environment and human health due to the potential presence of hazardous substances in EEE. For proper collection and treatment, contact your local IBM representative.

Disposal of IT products should be in accordance with local ordinances and regulations.

Battery return program

This product may contain sealed lead acid, nickel cadmium, nickel metal hydride, lithium, or lithium ion battery. Consult your user manual or service manual for specific battery information. The battery must be recycled or disposed of properly. Recycling facilities may not be available in your area. For information on disposal of batteries outside the United States, go to <http://www.ibm.com/ibm/environment/products/batteryrecycle.shtml> or contact your local waste disposal facility.

In the United States, IBM has established a return process for reuse, recycling, or proper disposal of used IBM sealed lead acid, nickel cadmium, nickel metal hydride, and other battery packs from IBM equipment. For information on proper disposal of these batteries, contact IBM at 1-800-426-4333. Please have the IBM part number listed on the battery available prior to your call.

For Taiwan:



Please recycle batteries.

For the European Union:



Notice: This mark applies only to countries within the European Union (EU)

Batteries or packaging for batteries are labeled in accordance with European Directive 2006/66/EC concerning batteries and accumulators and waste batteries and accumulators. The Directive determines the framework for the return and recycling of used batteries and accumulators as applicable throughout the European Union. This label is applied to various batteries to indicate that the battery is not to be thrown away, but rather reclaimed upon end of life per this Directive.

In accordance with the European Directive 2006/66/EC, batteries and accumulators are labeled to indicate that they are to be collected separately and recycled at end of life. The label on the battery may also include a chemical symbol for the metal concerned in the battery (Pb for lead, Hg for mercury and Cd for cadmium). Users of batteries and accumulators must not dispose of batteries and accumulators as unsorted municipal waste, but use the collection framework available to customers for the return, recycling and treatment of batteries and accumulators. Customer participation is important to minimize any potential effects of batteries and accumulators on the environment and human health due to the potential presence of hazardous substances. For proper collection and treatment, contact your local IBM representative.

For California:

Perchlorate material – special handling may apply

Refer to <http://www.dtsc.ca.gov/hazardouswaste/perchlorate>.

The foregoing notice is provided in accordance with *California Code of Regulations Title 22, Division 4.5, Chapter 33: Best Management Practices for Perchlorate Materials*. This product/part includes a lithium manganese dioxide battery which contains a perchlorate substance.

Flat panel displays

The fluorescent lamp in the liquid crystal display contains mercury. Dispose of it as required by local ordinances and regulations.

Monitors

Connecticut - Please see the web site of the Department of Environmental Protection at <http://www.ct.gov/dep> for information about recycling covered electronic devices in the State of Connecticut, or telephone the Connecticut Department of Environmental Protection at 1-860-424-3000.

Washington - Please see the web site of the Department of Ecology at <http://1800recycle.wa.gov/> for information about recycling covered electronic devices in the State of Washington, or telephone the Washington Department of Ecology at 1-800Recycle.

Trademarks

The following are trademarks of International Business Machines Corporation in the United States or other countries, or both:

AnyPlace Kiosk(tm)
AnyPlace POS Hub(tm)
DB2
DB2 Universal Database
IBM and the IBM logo
PS/2
SureMark
SurePoint
SurePOS
Wake on LAN
WebSphere

Microsoft, Windows, Windows NT, and the Windows logo are trademarks of Microsoft Corporation in the United States, other countries, or both.

Celeron and Intel are trademarks of Intel corporation in the United States, or other countries.

Java and all Java-based trademarks and logos are trademarks or registered trademarks of Sun Microsystems, Inc. in the United States, or other countries, or both.

Other company, product, or service names may be trademarks or service marks of others.

Index

A

acceptor, bill 26
acceptor, coin 24
accessibility of publications vii

B

bag rack 73
bagging 68
bagging cabinet, Models 152, 602, and 612 112
bagging cabinet, Models 153, 603, and 613 114
bagging cabinet, Models 171, 800, and 810 118
bagging cabinet, N54 116
battery
 sealed lead acid, recycling viii
battery return program 130
battery, European Union 131
bill acceptor 26
bill dispenser 6
bill dispenser cassette 16
bill dispenser communications 18
bill dispenser lower unit 14
bill dispenser main unit 9
bill dispenser power 18
BOSS 77
bumpers, Models 171, 800, and 810 120

C

cabinet parts 105
cabinet, core module 106
cabinet, Models 152, 602, and 612 bagging 112
cabinet, Models 153, 603, and 613 bagging 114
cabinet, Models 171, 800, and 810 bagging
 cabinet 118
cabinet, N54 bagging cabinet 116
cabinet, security conveyor 110
cabinet, transport conveyor 110
cable ferrite requirement 129
cables 89, 90
capture, signature 46
cassette, bill dispenser 16
CD-ROM vii
cell, load 53
Class A compliance statement
 Australia and New Zealand 128
 European Union 127
 FCC (USA) 127
 Germany 128
 Industry Canada 128
 Japan 128
coin acceptor 24
coin dispenser 20
conveyor, security 59, 60
conveyor, transport 64
core module 1
core module cabinet 106

countertop 44
coupon acceptor 46

D

damage from electrostatic discharge 129
detectors, Models 171, 800, and 810 122
dispenser communications, bill 18
dispenser power, bill 18
dispenser, bill 6
dispenser, cassette bill 16
dispenser, coin 20
dispenser, lower unit bill 14
dispenser, main unit bill 9
disposal of equipment viii, 129

E

electronic emissions notices 127
 Australia and New Zealand 128
 European Union 127
 FCC (USA) 127
 Germany 128
 Industry Canada 128
 Japan 128
electrostatic discharge (ESD) 129
emitters, Models 171, 800, and 810 122
end of life disposal viii, 129
EPO button 85
equipment disposal viii, 129

F

ferrite requirement 129
field kits 101
flat panel displays 132

H

how to use this manual v

J

Japanese power line harmonics compliance
 statement 128
Japanese Voluntary Control Council for Interference
 statement 129

K

keys 95
kits, field 101

L

lane light 48
lane PC 50
light, lane 48
load cell 53
locks 95
lower unit, bill dispenser 14

M

main unit, bill dispenser 9
mercury-added statement 132
module, core 1

N

notices 125
 battery recycling 130
 cable ferrites 129
 electronic emissions 127
 electrostatic discharge (ESD) 129
 end of life disposal 129
 IBM 125

O

order separators, Models 171, 800, and 810 120

P

Paystation, integrated 81
PC, lane 50
perchlorate 131
power cords 92
publications, related vi

R

recycling
 sealed lead acid battery viii
Red (EPO) button 85
related publications vi

S

safety vii
safety information vii
security conveyor 59, 60
security conveyor cabinet 110
sensors, Models 171, 800, and 810 122
signature capture 46
soft goods shelf, Models 171, 800, and 810 120

T

Taiwanese battery recycling statement 130
trademarks 132
transport conveyor 64
transport conveyor cabinet 110

U

using this manual v

W

Web site vii
wire bag rack 73

Part number index

Part Number	Asm-Index	Page	Part Number	Asm-Index	Page
01L1637	1-	3	28R3559	31-12	91
03N6669	21-3	51	28R3559	31-13	91
04G5389	5-9	13	28R3565	31-11	91
10N9421	21-2	51	28R3587	1-37	4
10N9422	21-2	51	28R3589	31-14	91
10N9428	21-2	51	28R3595	1-	4
10N9431	21-2	51	28R3678	9-15	22
10N9432	21-2	51	28R3679	9-15	22
10N9434	21-2	51	28R3680	9-15	22
10N9435	21-2	51	28R3684	11-5	27
10N9437	21-2	51	28R3684	31-26	91
10N9439	21-2	51	28R3786	1-14	3
10N9440	21-2	51	28R5399	9-15	22
10N9441	21-2	51	28R5455	1-4	3
12R9478	36-20	107	28R5466	9-15	22
14J1054	1-	3	28R5540	27-2	75
23K8035	28-	79	28R5566	10-	25
28R3172	24-22	61	32N1205	21-2	51
28R3172	25-12	65	32N1206	21-2	51
28R3173	27-1	75	32N1207	21-2	51
28R3189	25-2	65	32N1208	21-2	51
28R3190	24-21	61	32N1209	21-2	51
28R3191	24-15	61	32N1210	21-2	51
28R3192	24-17	61	32N1216	21-2	51
28R3194	24-16	61	32N1218	21-2	51
28R3194	25-19	65	32N1220	21-2	51
28R3195	24-20	61	32N1224	21-2	51
28R3195	25-16	65	32N1236	21-2	51
28R3196	24-5	61	39M5073	32-2	93
28R3196	25-1	65	39M5081	9-	22
28R3197	24-27	62	39M5107	32-1	93
28R3197	25-7	65	39M5177	32-3	93
28R3274	25-2	65	39M5374	8-1	19
28R3275	24-6	61	39M5376	1-	4
28R3275	25-6	65	39M5377	9-	22
28R3276	24-21	61	40M9341	11-	27
28R3277	24-15	61	40M9342	11-	27
28R3278	24-17	61	40M9343	11-	27
28R3279	24-18	61	40M9366	1-4	3
28R3279	25-5	65	40M9400	31-6	91
28R3283	24-10	61	40M9400	8-2	19
28R3283	25-10	65	40M9423	24-	62
28R3284	24-7	61	40M9423	31-15	91
28R3284	25-11	65	40M9469	1-3	3
28R3285	24-8	61	40M9470	1-2	3
28R3285	25-9	65	40M9470	31-8	91
28R3292	10-3	25	40M9472	1-23	4
28R3298	24-6	61	40M9472	31-3	91
28R3298	25-6	65	40N4716	1-	4
28R3559	1-	4	40N5606	8-	19

Part Number	Asm-Index	Page	Part Number	Asm-Index	Page
40N6220	1-5	3	41D7139	2-5	7
40N6224	1-5	3	41D7142	16-15	41
41A3391	28-	79	41D7144	16-16	41
41D1011	17-2	43	41D7146	25-15	65
41D1013	17-2	43	41D7150	25-21	65
41D1015	17-2	43	41D7155	16-4	41
41D1017	17-2	43	41D7156	16-5	41
41D1337	19-	47	41D7161	18-6	45
41D7009	35-	103	41D7163	18-16	45
41D7043	9-	21	41D7169	16-	41
41D7045	9-	21	41D7211	1-	3
41D7047	9-	21	41D7213	2-6	7
41D7051	9-	21	41D7215	2-8	7
41D7053	2-7	7	41D7217	6-3	15
41D7053	7-	17	41D7242	17-	43
41D7061	16-17	41	41D7246	16-7	41
41D7068	1-34	4	41D7248	11-4	27
41D7072	31-	91	41D7249	11-2	27
41D7073	1-	4	41D7250	11-	27
41D7073	22-	55	41D7251	11-3	27
41D7073	31-	91	41D7252	11-2	27
41D7073	31-16	91	41D7253	11-3	27
41D7073	31-17	91	41D7254	11-	27
41D7073	31-18	91	41D7320	29-2	83
41D7073	31-19	91	41D7323	23-1	57
41D7073	31-2	91	41D7324	23-	57
41D7073	31-22	91	41D7344	36-19	107
41D7075	31-	91	41D7391	29-1	83
41D7076	9-4	21	41D7403	9-	22
41D7078	9-4	21	41D7404	9-	22
41D7080	1-18B	4	41D7424	20-	49
41D7082	1-18C	4	41D7426	20-	49
41D7083	1-14	3	41D7428	20-	49
41D7101	35-	104	41D7430	20-	49
41D7103	5-2	13	41D7448	22-1	55
41D7105	4-1	11	41D7451	22-1	55
41D7107	5-3	13	41D7453	22-1	55
41D7109	5-8	13	41D7557	20-	49
41D7111	5-7	13	41D7563	5-4	13
41D7113	5-6	13	41D7563	6-6	15
41D7115	7-1	17	41D7586	16-8	41
41D7117	7-3	17	41D7588	16-	41
41D7119	3-2	9	41D7595	16-	41
41D7121	6-5	15	41D7596	21-	51
41D7123	2-	7	41D7610	5-9	13
41D7125	5-5	13	41D7621	22-	55
41D7125	6-7	15	41D7621	26-	71
41D7127	2-	7	41D7622	22-1	55
41D7129	7-	17	41D7634	16-18	41
41D7131	7-6	17	41D7635	23-3	57
41D7133	3-5	9	41D7636	23-2	57
41D7135	2-3A	7	41D7656	20-	49
41D7137	2-4	7	41D7667	23-5	57

Part Number	Asm-Index	Page	Part Number	Asm-Index	Page
41D7669	23-6	57	41D8772	42-4	121
41D7671	23-7	57	41D8774	42-5	121
41D7680	16-9	41	41D8776	42-6	121
41D7704	20-2	49	41D8778	42-7	121
41D7706	20-2	49	41D8780	42-8	121
41D7767	16-11	41	41D9327	23-	57
41D7775	1-	4	41D9329	1-25	4
41D7813	9-6	21	41D9330	1-29	4
41D7815	9-6	21	41D9345	10-1	25
41D7977	20-2	49	41D9346	10-1	25
41D8051	10-1	25	41D9347	10-1	25
41D8054	20-	49	41D9348	10-1	25
41D8056	20-	49	41D9349	10-1	25
41D8060	9-18	22	41D9350	35-	104
41D8062	9-18	22	41D9351	35-	104
41D8114	19-4	47	41D9352	35-	104
41D8116	29-	83	41D9353	35-	104
41D8118	29-	83	41D9354	35-	104
41D8119	41-	119	41D9355	35-	104
41D8143	16-14	41	41D9359	1-34	4
41D8184	23-	57	41D9361	31-22	91
41D8185	26-	71	41D9435	17-	43
41D8187	26-	71	41D9560	19-1	47
41D8188	22-1	55	41D9561	19-15	47
41D8190	26-	71	41D9626	18-7	45
41D8192	26-	71	41D9628	18-15	45
41D8193	26-	71	41D9631	35-	104
41D8194	26-7	71	41D9642	12-	29
41D8195	26-4	71	41D9644	12-	30
41D8196	23-	57	41D9648	12-	29
41D8199	2-11	7	41D9650	12-	29
41D8229	9-17	22	41D9653	13-	33
41D8231	9-16	22	41D9653	13-	33
41D8291	22-	55	41D9655	13-	33
41D8382	36-	107	41D9655	13-	34
41D8383	36-	107	41D9700	11-2	27
41D8391	16-10	41	41D9701	11-2	27
41D8445	17-2	43	41D9702	11-2	27
41D8448	17-2	43	41D9703	11-2	27
41D8449	17-	43	41D9744	26-3	71
41D8555	20-	49	41D9769	25-3	65
41D8557	20-	49	41D9782	24-3	61
41D8560	27-	75	41D9783	24-14	61
41D8573	15-1	39	41D9783	24-24	62
41D8576	15-4	39	41D9784	24-32	62
41D8579	15-3	39	41D9785	24-30	62
41D8628	18-5	45	41D9786	24-30	62
41D8630	18-14	45	41D9787	24-33	62
41D8764	42-	121	41D9788	24-33	62
41D8766	42-	121	41D9803	24-30	62
41D8768	42-	121	41D9804	24-30	62
41D8770	42-	121	41D9816	24-4	61
41D8772	42-3	121	41D9818	25-4	65

Part Number	Asm-Index	Page	Part Number	Asm-Index	Page
41D9820	25-4	65	41J7434	25-	65
41D9822	24-4	61	41J7436	24-	61
41D9876	16-19	41	41J7438	25-	65
41E1449	11-	27	41J7440	24-	61
41E1619	31-21	91	41J7442	25-	65
41E1748	24-	62	41J7444	24-	61
41E1749	24-	62	41J7446	25-	65
41E1829	19-6	47	41J7448	24-19	61
41E1830	19-	47	41J7448	25-17	65
41E1830	31-5	91	41J7450	24-19	61
41E1831	19-	47	41J7450	25-17	65
41E1831	31-4	91	41J7452	31-	91
41E1832	1-	4	41J7533	18-8	45
41E1849	1-11	3	41J7536	18-18	45
41E1850	1-12	3	41J7615	9-1	21
41E1851	1-9	3	41J7616	9-1	21
41E1854	19-5	47	41J7617	9-1	21
41E1855	19-5	47	41J7618	9-1	21
41E1858	18-1	45	41J7619	9-1	21
41E1859	18-11	45	41J7620	9-1	21
41E1861	18-3	45	41J7621	9-1	21
41E1862	18-13	45	41J7622	9-1	21
41E1863	19-	47	41J7623	9-1	21
41E1864	19-	47	41J7624	9-1	21
41E1865	1-39	4	41J7625	9-1	21
41E1865	20-	49	41J7626	9-1	21
41E1866	2-1	7	41J7627	9-1	21
41J6659	36-48	107	41J7628	9-1	21
41J6735	10-1	25	41J7629	9-1	21
41J6736	10-1	25	41J7630	9-1	21
41J6737	10-1	25	41J7631	9-1	21
41J6738	10-1	25	41J7632	9-1	21
41J6739	10-1	25	41J7633	9-1	21
41J6745	18-9	45	41J7634	9-1	21
41J6746	18-4	45	41J7635	9-	22
41J6747	18-2	45	41J7636	9-	22
41J6748	18-17	45	41J7637	9-	22
41J6749	18-10	45	41J7638	9-9	21
41J6750	18-12	45	41J7639	9-9	21
41J6928	25-14	65	41J7640	9-9	21
41J6930	22-	55	41J7641	9-9	21
41J6934	22-	55	41J7642	9-9	21
41J7093	19-14	47	41J7643	9-9	21
41J7094	19-13	47	41J7644	9-9	21
41J7126	25-	65	41J7645	9-9	21
41J7126	42-1	121	41J7646	9-9	21
41J7127	25-	65	41J7648	9-9	21
41J7127	42-1	121	41J7649	9-9	21
41J7193	16-6	41	41J7651	9-9	21
41J7417	22-	55	41J7654	9-9	22
41J7425	25-20	65	41J7655	9-9	22
41J7426	25-13	65	41J7658	9-10	22
41J7432	24-	61	41J7659	9-11	22

Part Number	Asm-Index	Page	Part Number	Asm-Index	Page
41J7666	24-9	61	41J9298	1-4	3
41J7666	25-8	65	41J9310	25-4	65
41J7676	24-	62	41J9312	24-4	61
41J7678	24-28	62	41J9318	25-4	65
41J7731	31-23	91	41J9320	24-4	61
41J7798	19-7	47	41J9330	11-	27
41J8076	10-7	25	41J9416	12-8	29
41J8193	20-	49	41J9416	12-8	29
41J8194	20-	49	41J9418	12-8	29
41J8195	20-	49	41J9418	12-8	30
41J8231	10-2	25	41J9418	14-9	37
41J8332	25-18	65	41J9418	14-9	37
41J8334	25-18	65	41J9438	12-6	29
41J8336	24-	62	41J9440	12-6	29
41J8336	25-	65	41J9440	14-5	37
41J8338	24-18	61	41J9442	12-1	29
41J8340	24-2	61	41J9444	12-1	29
41J8342	24-25	62	41J9447	12-5	29
41J8344	24-12	61	41J9447	12-5	29
41J8393	32-4	93	41J9449	12-5	29
41J8414	24-	62	41J9449	12-5	29
41J8438	25-5	65	41J9449	14-6	37
41J8450	25-15	65	41J9449	14-6	37
41J8452	25-21	65	41J9452	12-7	29
41J8791	24-1	61	41J9452	12-7	29
41J8807	12-4	29	41J9452	13-1	33
41J8807	12-4	29	41J9452	13-1	33
41J8807	13-7	33	41J9454	12-7	29
41J8807	13-7	33	41J9454	12-7	29
41J8807	14-3	37	41J9454	13-1	33
41J8807	14-3	37	41J9454	13-1	33
41J8809	12-4	29	41J9454	14-4	37
41J8809	12-4	29	41J9454	14-4	37
41J8809	13-7	33	41J9457	12-3	29
41J8809	13-7	33	41J9457	12-3	29
41J8848	24-2	61	41J9457	13-4	33
41J8850	24-13	61	41J9457	13-4	33
41J8854	24-	61	41J9459	12-3	29
41J8854	25-	65	41J9459	12-3	29
41J8855	25-	65	41J9459	13-4	33
41J8856	25-	65	41J9459	13-4	33
41J8867	24-3	61	41J9459	14-2	37
41J8869	24-23	62	41J9459	14-2	37
41J8883	16-1	41	41J9461	12-6	29
41J8896	24-1	61	41J9463	12-6	29
41J9127	24-2	61	41J9463	14-5	37
41J9135	1-32	4	41J9465	12-1	29
41J9154	16-13	41	41J9467	12-1	29
41J9157	16-12	41	41J9513	13-6	33
41J9289	19-8	47	41J9515	13-6	33
41J9295	1-4	3	41J9518	13-6	33
41J9296	1-4	3	41J9520	13-6	33
41J9297	1-4	3	41J9523	13-10	33

Part Number	Asm-Index	Page	Part Number	Asm-Index	Page
41J9525	13-10	33	41K6089	1-28	4
41J9528	13-10	33	41K6090	1-28	4
41J9530	13-10	34	41K6094	34-3	99
41J9533	13-2	33	41K6098	34-	99
41J9533	13-2	33	41K6099	34-	99
41J9535	13-2	33	41K6100	34-	99
41J9535	13-2	33	41K6102	36-40	107
41J9538	13-8	33	41K6103	36-9	107
41J9538	13-8	33	41K6104	34-6	99
41J9540	13-8	33	41K6105	34-4	99
41J9540	13-8	33	41K6106	36-41	107
41J9542	1-38	4	41K6108	36-	107
41J9544	24-29	62	41K6109	11-6	27
41J9546	24-29	62	41K6120	1-27	4
41J9660	16-3	41	41K6120	33-4	97
41J9662	16-2	41	41K6121	33-4	97
41J9666	14-1	37	41K6122	33-4	97
41J9670	14-1	37	41K6123	33-4	97
41J9748	23-4	57	41K6124	33-4	97
41J9750	40-	117	41K6125	33-4	97
41J9751	40-	117	41K6126	33-4	97
41J9752	40-	117	41K6127	33-4	97
41J9765	16-	41	41K6128	33-4	97
41J9770	12-2	29	41K6129	33-4	97
41J9770	12-2	29	41K6130	33-5	97
41J9770	13-9	33	41K6131	33-5	97
41J9770	13-9	33	41K6132	33-5	97
41J9772	12-2	29	41K6133	33-5	97
41J9772	12-2	29	41K6134	33-5	97
41J9772	13-9	33	41K6135	33-5	97
41J9772	13-9	33	41K6136	33-5	97
41J9812	17-2	43	41K6137	33-5	97
41J9817	17-2	43	41K6138	33-5	97
41J9835	31-	91	41K6139	33-5	97
41J9838	1-19	4	41K6140	36-42	107
41J9839	1-18	3	41K6141	36-42	107
41J9841	1-18	3	41K6142	36-44	107
41J9845	24-11	61	41K6143	36-46	107
41J9845	24-12	61	41K6144	36-45	107
41J9849	24-25	62	41K6145	36-46	107
41J9849	24-26	62	41K6146	36-45	107
41J9891	1-41	4	41K6147	36-	108
41J9916	1-22	4	41K6148	36-13	107
41K6077	9-14	22	41K6149	36-17	107
41K6080	8-3	19	41K6150	36-15	107
41K6082	9-2	21	41K6151	36-30	107
41K6083	36-43	107	41K6152	36-30	107
41K6086	9-2	21	41K6153	36-30A	107
41K6087	1-26	4	41K6154	36-24	107
41K6087	33-2	97	41K6155	36-24	107
41K6087	34-5	99	41K6156	36-25	107
41K6088	33-1	97	41K6157	36-32	107
41K6088	9-8	21	41K6159	36-	107

Part Number	Asm-Index	Page	Part Number	Asm-Index	Page
41K6160	10-9	25	41K6387	41-	119
41K6161	1-35	4	41K6388	41-2	119
41K6162	36-26	107	41K6391	41-4	119
41K6163	36-26	107	41K6398	2-9	7
41K6164	36-11	107	41K6399	2-10	7
41K6165	36-	107	41K6572	36-	107
41K6166	1-30	4	41K6576	19-2	47
41K6167	36-22	107	41K6585	34-2	99
41K6168	36-22	107	41K6593	10-6	25
41K6284	35-	104	41K6595	36-	107
41K6289	3-1	9	41K6597	34-4	99
41K6290	3-4	9	41K6600	36-12	107
41K6291	6-9	15	41K7080	30-2	87
41K6298	7-2	17	41K7082	30-1	87
41K6300	7-4	17	41K7093	27-3	75
41K6301	7-5	17	41K7207	9-14	22
41K6303	3-3	9	41K7208	9-14	22
41K6306	6-2	15	41K7209	9-14	22
41K6307	6-4	15	41K7210	9-14	22
41K6308	6-1	15	41K7211	9-14	22
41K6309	6-8	15	42H1161	24-	62
41K6318	2-2	7	42H1161	25-	65
41K6319	2-3	7	42K0050	36-	108
41K6322	7-8	17	42K0051	36-31	107
41K6352	31-24	91	42K0052	10-4	25
41K6352	9-	22	42K0053	10-4	25
41K6353	9-13	22	42K0056	36-3	107
41K6354	10-	25	42K0057	36-29	107
41K6354	31-27	91	42K0058	10-7	25
41K6355	1-18	4	42K0061	7-7	17
41K6356	1-18	4	42K0062	7-7	17
41K6359	10-	25	42K0063	7-7	17
41K6359	31-27	91	42K0064	7-7	17
41K6363	10-10	25	42K0068	36-5	107
41K6363	9-5	21	42K0080	34-1	99
41K6364	10-10	25	42K0081	34-1	99
41K6364	9-5	21	42K0082	34-1	99
41K6365	31-25	91	42K0083	34-1	99
41K6367	19-9	47	42K0084	34-1	99
41K6368	1-	4	42K0085	34-1	99
41K6368	31-9	91	42K0086	34-1	99
41K6369	1-	4	42K0087	34-1	99
41K6369	31-29	91	42K0088	34-1	99
41K6370	1-	3	42K0089	34-1	99
41K6370	31-28	91	42K0090	34-	99
41K6371	20-1	49	42K0091	34-	99
41K6379	42-2	121	42K0092	34-	99
41K6382	37-20	111	42K0093	34-	99
41K6382	37-22	111	42K0094	34-	99
41K6382	38-	113	42K0095	34-	99
41K6384	41-11	119	42K0096	34-	99
41K6385	41-10	119	42K0097	34-	99
41K6386	41-9	119	42K0098	34-	99

Part Number	Asm-Index	Page	Part Number	Asm-Index	Page
42K0099	34-	99	44D0987	19-1	47
42K0355	10-5	25	44D0989	19-	47
42K0356	1-16	3	44D0991	19-	47
42K0357	19-11	47	44D1022	19-	47
42K0358	1-17	3	44D1023	19-	47
42K0358	19-10	47	44D1125	1-	4
42K0359	10-5	25	44D1130	19-	47
42K0360	1-16	3	44D1131	19-	47
42M5632	1-	3	44D1151	38-4	113
42M5667	1-	3	44D1151	39-1	115
44D0241	17-1A	43	44D1157	1-4	3
44D0243	17-1B	43	44D1161	19-	47
44D0244	33-3	97	44D1165	31-20	91
44D0245	10-8	25	44D1232	20-	49
44D0246	10-8	25	44D1294	9-	21
44D0252	15-1	39	44D1296	9-9	21
44D0254	15-4	39	44D1337	19-12	47
44D0256	15-3	39	44D1363	38-1	113
44D0258	11-1	27	44D1363	39-7	115
44D0260	11-7	27	44D1364	39-2	115
44D0262	11-8	27	44D1365	38-7	113
44D0264	41-1	119	44D1366	38-	113
44D0265	41-	119	44D1606	35-	104
44D0266	41-	119	44D1776	35-	104
44D0274	41-	119	44M1624	43-11	123
44D0347	16-20	41	44M1643	31-	91
44D0359	15-2	39	44M1749	41-	119
44D0361	15-2	39	44M1840	7-9	17
44D0381	15-5	39	44M1846	1-4	3
44D0381	15-5	39	44M1884	20-	49
44D0405	25-	65	44M1886	20-	49
44D0407	25-	65	44M1899	25-	65
44D0412	35-	104	44M1900	25-	65
44D0421	20-2	49	44M1901	19-3	47
44D0448	1-	4	44M1902	19-3	47
44D0533	35-	104	44M1913	25-18	65
44D0534	35-	104	44M1914	25-18	65
44D0750	19-1	47	44M1959	36-47	107
44D0852	42-	121	44M1961	36-47	107
44D0853	42-	121	44M1975	26-8	71
44D0854	41-14	119	44M1976	26-9	71
44D0855	41-	119	44M1977	26-10	71
44D0856	41-	119	44M1992	41-	119
44D0857	41-	119	44M1995	41-3	119
44D0859	38-5	113	44M2123	41-	119
44D0860	39-3	115	44M2154	35-	104
44D0861	29-3	83	44M2155	35-	104
44D0862	29-4	83	44M2189	24-32	62
44D0872	1-	4	44M2232	24-34	62
44D0874	1-	4	NA	31-1	91
44D0920	15-	39	NA	31-10	91
44D0922	15-	39	NA	31-7	91



Updated October 16, 2007

S131-0106-02



Free Manuals Download Website

<http://myh66.com>

<http://usermanuals.us>

<http://www.somanuals.com>

<http://www.4manuals.cc>

<http://www.manual-lib.com>

<http://www.404manual.com>

<http://www.luxmanual.com>

<http://aubethermostatmanual.com>

Golf course search by state

<http://golfingnear.com>

Email search by domain

<http://emailbydomain.com>

Auto manuals search

<http://auto.somanuals.com>

TV manuals search

<http://tv.somanuals.com>