

3M™ Shoes and Wrist Strap Tester 747

User's Guide



Table of Contents

Section	Page
Introduction	2
Inspection	2
Package Contents.....	2
Safety Information.....	3
Intended Use.....	3
Chapter 1.0 Overview.....	5
1.1 Product outline	5
1.2 Part Names and Functions	6
1.2.1 Front Panel	6
1.2.2 Side Panels.....	7
1.2.3 Back Side	7
Chapter 2.0 Preparation Before Testing.....	8
2.1 Connecting the ESD Shoe Testing	8
2.2 Threshold Resistance Settings	9
2.3 Power Preparation	10
2.3.1 Installing and Replacing the Batteries	10
2.3.2 AC Adapter Connection	11
2.4 Turning Power On and Off.....	11
2.5 Wall Mounting	12
Chapter 3.0 Testing.....	12
3.1 ESD Shoe Testing.....	13
3.2 ESD Wrist Strap Testing	14
Chapter 4.0 External Output Function	14
4.1 Open Collector Output.....	14
4.2 RS-232C Communications	18
4.3 Card Read Technical Specifications.....	19
4.4 PC System Requirements.....	19
Chapter 5.0 Specification	20
5.1 Measurement Section.....	20
5.2 General Specifications	21
Chapter 6.0 Maintenance & Service.....	21
6.1 Battery Replacement Indicator	21
6.2 Error Messages	22
6.3 Before Returning the 3M™ Shoes and Wrist Strap Tester 747 for Service.....	22
6.4 Cleaning.....	23
Chapter 7.0 Operational Verification Test of Shoes and Wrist Strap Tester 747	23
Regulatory Information	27
Warranty.....	29

Introduction

Thank you for purchasing this 3M™ Shoes and Wrist Strap Tester 747. To get the maximum performance from the unit, please read this user's guide first, and refer to it as needed.

Inspection

The AC adapter provided with the Shoes and Wrist Strap Tester 747 varies according to region. In North America, the Shoes and Wrist Strap Tester 747 is provided with the SA10-0910N AC adapter, while in Europe it is provided with the SA 10-0910G AC adapter. Before using the Shoes and Wrist Strap Tester 747, make sure that you have the correct AC adapter for your region.

When the unit is delivered, check and make sure that it has not been damaged, or fails to operate according to the specifications, contact your dealer or 3M representative.

Package Contents

AC Adapter	1
ESD Shoe Testing Cord	1
Wall-Mounting Board	1
3M™ Data Logging Software 747DLS	1
ESD Shoe Testing Plate	1
Mounting Screw for ESD Shoe Testing Plate (with washer)	1
Alkaline Battery	6
Null Modem Cable 1.8 m	1
Quick Guide Test Card	1







SAFETY INFORMATION

Read, understand and follow all safety information before operating this equipment. Retain this User's Guide for future reference.

Intended Use:

The 3M™ Shoes and Wrist Strap Tester 747 is a single-unit instrument designed especially to measure electrical resistance for evaluating the effectiveness of ESD (electrostatic discharge) shoes and wrist straps used to protect static sensitive devices during handling.

Explanation of Safety Label Signal Words & Symbols

Warning	Indicates a potentially hazardous situation, which, if not avoided, may result in death or serious injury.
Caution	Indicates a potentially hazardous situation, which, if not avoided, may result in minor or moderate injury and/or property damage.
	CAUTION: read operating instructions
	WARNING: read operating instructions
	Indicates the ON side of the power switch.
	Indicates the OFF side of the power switch.
	Indicates DC (Direct Current).
	Power input connector polarity (center positive)
	See user instruction manual for explanation of indicator lamps



WARNING

Do not use power supply to power unit in Europe. Unit is intended to be powered by non-rechargeable battery and input connector is not to be used.

To reduce the risks associated with an explosion hazard, which, if not avoided, could result in death or serious injury:

- Do not use in an explosive environment. 3M™ Shoe and Wrist Strap Tester 747 is not designed to be intrinsically safe.

To reduce the risks associated with a medical device malfunction, which, if not avoided, could result in death or serious injury:

- Persons with heart pacemaker devices should never use this Shoes and Wrist Strap Tester 747.



CAUTION

To reduce the risks associated with hazardous voltage, which, if not avoided,, may result in minor or moderate injury and/or property damage:

- AC adapter must have all local required regulatory certifications.
- Do not use AC adapter and/or power cord if damaged.
- When replacing batteries, turn the power switch off and disconnect all the cables before beginning.
- Do not use in an outdoor and/or wet environment.
- Not intended to be serviced by the user. No user serviceable parts.
- Always replace battery cover before using the Shoes and Wrist Strap Tester 747.

To reduce the risks associated with electrostatic discharge (ESD), which, if not avoided, may result in property damage to electronic components or assemblies being handled:

- Perform operational verification test to ensure proper operation of the Shoes and Wrist Strap Tester 747 as required.

To reduce the risk associated with environmental contamination, which, if not avoided, may result in-contamination of land, water or air:

- Dispose of Shoes and Wrist Strap Tester 747 and/or batteries in accordance with governmental regulations at the end of product-life.

1.0 Overview

1.1 Product Outline



WARNING

To reduce the risks associated with an explosion hazard, which, if not avoided, could result in death or serious injury:

- Do not use in an explosive environment. 3M™ Shoes and Wrist Strap Tester 747 is not designed to be intrinsically safe.

To reduce the risks associated with a medical device malfunction, which, if not avoided, could result in death or serious injury:

- Persons with heart pacemaker devices should never use this Shoes and Wrist Strap Tester 747.

The 3M™ Shoes and Wrist Strap Tester 747 features:

- (1) Evaluation of Electrostatic Protection Provided by ESD Shoes and Wrist Straps
A single device measures the electrical resistance of a body while wearing ESD shoes and wrist straps.
- (2) Quick Measurements
Displays value and test results, and makes the results available for output within one second after starting measurement.
- (3) Power Saver Function
Conserves power by automatically turning off (or entering stand-by state during AC operation) ten second after completing a measurement.
- (4) Test Result Display and Output
Displays OK, HIGH, or LOW test results on panel LEDs. Testing threshold resistance values are set by simple switch selections. Results are also available at an open-collector output terminal. Refer to Section 4.1, “Open Collector Output.”
- (5) RS-232C Interface
Test results are available to an external PC through a serial (RS-232C) interface. Refer to section 4.2, “RS-232C Communications.”

1.2 Part Names of the 3M™ Shoes and Wrist Strap Tester 747

1.2.1 Front Panel

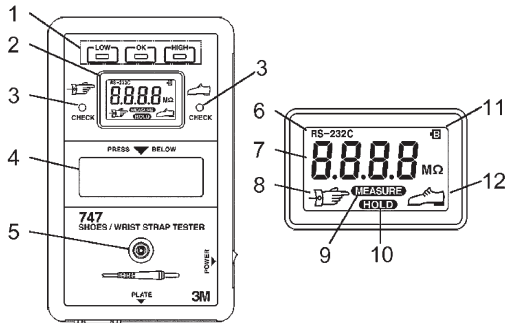

1. Test Result LEDs – Indicates test results according to specified threshold resistance.
2. LCD – Shows measurement values and test location status.
3. Test Location LEDs –Indicate the test location and status.
4. Touch Panel –The touch panel is the measurement terminal. (power switch and touching the panel initiate testing of the ESD measurement terminal)
5. Wrist Strap Connector – Connect the wrist strap cable here for wrist strap testing

LCD Indicators

6. RS-232C Indicator – Indicates serial communications is enabled.
7. Measurement Display – The measured value, decimal point and units are displayed
8. Wrist Strap Symbol – Indicated an ESD wrist strap is being tested.
9. MEASURE Indicator – Indicates a test (measurement) is in progress.
10. HOLD Indicator – Indicates a test is finished.
11. Battery Symbol – Appears when the battery is depleted and needs to be replaced.
12. Shoe Symbol –Indicates ESD shoes are being tested.

1.2.2 Side Panels

1. Power Switch – Turns the 3M™ Shoes and Wrist Strap Tester 747 on and off.
2. Threshold Resistance Selection Switches – Select the threshold resistances for shoes and wrist strap tests.
3. Test Result Output Selection Switch – Selects which test results are present at the OUTPUT terminal.
4. RS-232C Connector – Connect to a PC serial port using an RS-232C cable to transfer data.
5. ESD Shoe Testing Cable Connector – Connect to the supplied cable for shoe testing. The other end of this cable connects to the shoe testing plate.
6. Test Result OUPUT Jack – Test results are available from this open-collector output.
7. AC Adapter Input Jack – The supplied AC Adapter is connected here. Input voltage is 9VDC, center positive.

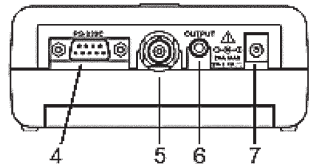
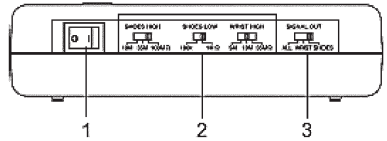

1.2.3 Back Side

1. Mounting Holes – These holes accommodate the hooks on the supplied wall-mount board for wall mounting.
2. Battery Cover – To operate batteries, install six “penlight” alkaline batteries under this cover.

 **CAUTION**

To reduce the risks associated with hazardous voltage, which, if not avoided, may result in minor or moderate injury and/or property damage:

- Not intended to be serviced by the user. No user serviceable parts.

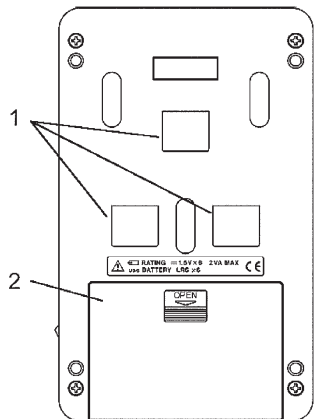

2.0 Preparation Before Testing

2.1 Connecting the ESD Shoe Testing Plate

WARNING

To reduce the risks associated with an explosion hazard, which, if not avoided, could result in death or serious injury:

- Do not use in an explosive environment. 3M™ Shoes and Wrist Strap Tester 747 is not designed to be intrinsically safe.

CAUTION

To reduce the risks associated with hazardous voltage, which, if not avoided, may result in minor or moderate injury and/or property damage:

- Do not use in an outdoor and/or wet environment.

The supplied shoe testing plate and cable must be connected to test ESD protective shoes. The cable for ESD shoe testing connects to the Shoes and Wrist Strap Tester 747 and the shoe testing plate as follows:

1. Connect the BNC-plug end of the cable to the ESD shoes testing cable connector as shown below.
2. Connect the other end of the cable in the shoe testing plate using the supplied M4 screw and washer.

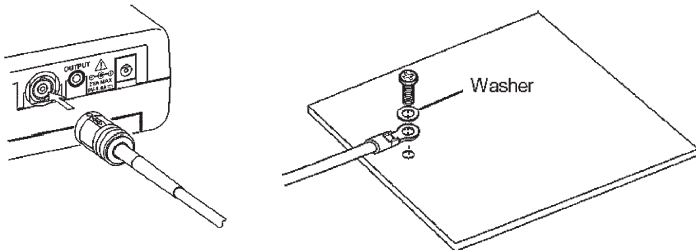

Important Note:

ESD wrist straps can be tested while the ESD shoe testing plate and cable are connected.

2.2 Threshold Resistance Settings for the 3M™ Shoes and Wrist Strap Tester 747

The test results indicated by the front panel LEDs are determined by comparison of the measured value with the threshold resistance settings (upper and lower limits).



LOW: the measured resistance is below the lower threshold

OK: the measured resistance is between the lower and upper thresholds

HIGH: the measured resistance is above the upper threshold

1. ESD Shoe Test Threshold Resistance Settings

The upper threshold (SHOES HIGH) and lower threshold (SHOES LOW) can be selected for shoe testing. Use tweezers to move the threshold switches

The upper threshold (SHOES HIGH) selections are 10, 35 or 100 Ω .

The lower threshold (SHOES LOW) selections are 100 k Ω or 1 Ω .

2. ESD Wrist Strap Test Threshold Resistance Settings

The upper threshold (WRIST HIGH) can be selected for wrist strap testing. Use tweezers to move the threshold switch.

The lower threshold is fixed at 1.65 Ω for wrist strap testing.

The upper threshold (WRIST HIGH) selections are 5, 10 or 35 M Ω .

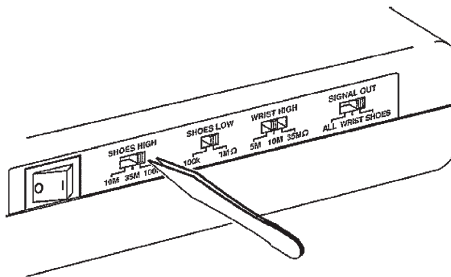

Important Notes:

- Factory default settings are 100 M Ω for SHOES HIGH, and 10 M Ω for WRIST HIGH, and 1 M Ω for SHOES LOW.
- The SIGNAL OUT selection is set to SHOES. When operated as a stand-alone tester (that is, when not using the external output), this SIGNAL OUT selection should be set to either WRIST or SHOES.

2.3 Power Preparation

2.3.1 Installing and Replacing the Batteries

CAUTION

To reduce the risks associated with hazardous voltage, which, if not avoided, may result in minor or moderate injury and/or property damage:

- When placing batteries, turn the power switch off and disconnect all the cables before beginning.
- Always replace battery cover before using the 3M™ Shoes and Wrist Strap Tester 747.

Important Notes:

- *To avoid electric shock when replacing the batteries, turn the power switch off and disconnect the all cables before beginning. Also, after replacing the batteries, always replace the cover before using the unit.*
- *When replacing the batteries, do not install old batteries with new ones, and do not mix different types of batteries. Check the battery polarity carefully when inserting the batteries.*
- *Do not short-circuit used batteries, disassemble them, or throw them in a fire. Doing so may cause the batteries to explode.*
- *Keep used batteries out of the reach of children. Dispose of used batteries according to their type in the prescribed manner and in the proper location.*
- *Remove the batteries before storage to prevent possible corrosion caused by battery leakage if the Shoes and Wrist Strap Tester 747 will not be used for a long period of time.*
- *When using the AC adapter, remove the batteries from the Shoes and Wrist Strap Tester 747 to prevent corrosion due to possible electrolyte leakage.*

This 3M™ Shoes and Wrist Strap Tester 747 can be operated from six “AA” alkaline batteries or the supplied AC adapter. The AC adapter has priority, so when the batteries are installed and the adapter is connected, battery power is not drained.

1. Confirm that the power switch is turned off.
2. Disconnect all cables from the Shoes and Wrist Strap Tester 747.
3. Remove the battery cover from the rear panel, and insert six fresh type “AA” batteries, with careful attention to the indicated polarity.
4. Replace the battery cover securely.

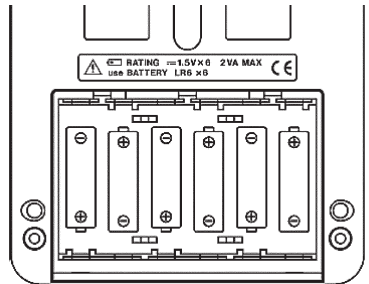

2.3.2 AC Adapter Connection

CAUTION

To reduce the risks associated with hazardous voltage, which, if not avoided, may result in minor or moderate injury and/or property damage:

- AC adapter must have all local required regulatory certifications.
- Do not use AC adapter and/or power cord if damaged.

This 3M™ Shoes and Wrist Strap Tester 747 can be operated from six “AA” alkaline batteries or the supplied AC adapter. The AC adapter has priority, so when the batteries are installed and the adapted is connected, battery power is not drained.

1. Confirm that the power switch is turned off.
2. Connect the output plug from the AC Adapter to the mating jack on the side panel.
3. Check to ensure that your AC mains voltage matches the voltage rating of the AC Adapter, and then plug it in.

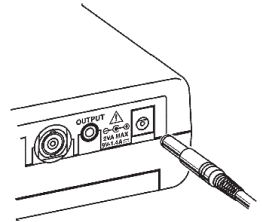

2.4 Turning Power On and Off

Turning Power On

1. Set the power switch on the side panel of the 3M™ Shoes and Wrist Strap Tester 747 to the on position (I).
2. Press a finger on the touch panel on the front of the Shoes and Wrist Strap Tester 747 to switch it on and begin a test.

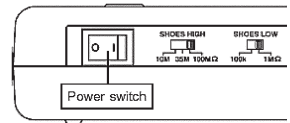

Turning Power Off

Set the power switch on the side panel to the off position (O).

Power Saver Function

The power saver function conserves power by automatically turning the Shoes and Wrist Strap Tester 747 off (or entering stand-by state during AC operation) ten seconds after completing a test. This function is disabled when using RS-232C communications.

Important Note:

When operating on batteries, the power saver function minimizes battery drain, although a very small amount of current is still required by the tester. Turn the power switch off to completely disconnect the batteries.

2.5 Wall Mounting

The supplied Wall-Mount Board allows the 3M™ Shoes and Wrist Strap Tester 747 to be easily mounted on the wall while still being readily removable.

As shown in the figure below, the board is affixed to the wall with three screws (either M4 machine screws or 4.1 mm diameter wood screws). The Shoes and Wrist Strap Tester 747 is then attached to the board by align in the back-side mounting holes over the hooks on the board.

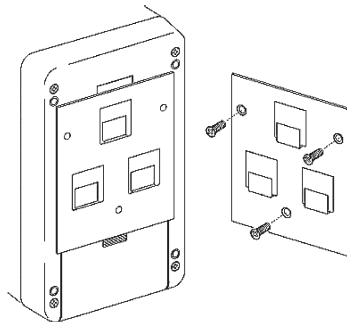

Important Note:

Screws are not included. Please use either M4 machine screws or wood screws with a nominal diameter of 4.1 mm for mounting. Either flat head or round head screws may be used.

3.0 Testing



CAUTION

To reduce the risks associated with electrostatic discharge (ESD), which, if not avoided, may result in property damage to electronic components or assemblies being handled.

- Perform operational verification test to ensure proper operation of the 3M™ Shoes and Wrist Strap Tester 747 as required.

When used as a stand-alone tester (that is, when not using the external output), the SIGNAL OUT test result output selector switch should be set to either WRIST or SHOES.

With the SIGNAL OUT switch set to either of these positions, both ESD shoes and wrist tests can be performed.

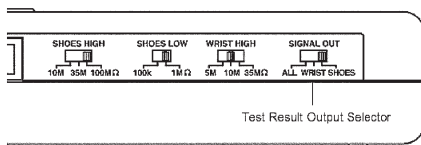

The ALL setting is described in Section 4.1, “Open Collector Output.”

Error Message	Meaning	Solution
Err.1	Finger removed from touch panel during measurement	Repeat the test
Err.2	Actual test type does not match specified test type	Check test type (location), and repeat the test
O.F.	Measured value exceeded 200.0 MΩ (Overflow)	Check test type and connections, and repeat the test

3.1 ESD Shoe Testing with the 3M™ Shoes and Wrist Strap Tester 747

This procedure tests the effectiveness of ESD protective shoes, and displays the actual measured resistance value along with the qualitative test result.

1. Ensure that the supplied shoes testing cable is connected between the shoe testing plate and the shoe testing connector. Refer to section 2.1, “Connecting the ESD Shoe Testing Plate.”
2. Select the required threshold resistance values. Refer to Section 2.2, “Threshold Resistance Settings (1).”
3. The wrist strap must not be connected to the front panel connector during shoe testing. If it is connected, remove it.
4. Step on the shoe testing plate, then press the touch panel with your finger. Continue pressing the touch panel until measurement is completed (until the **MEASURE** indicator goes out).

Testing starts and the following indicators are displayed:

- **MEASURE** and  symbol appear on the LCD.
- The shoe LED lights yellow.

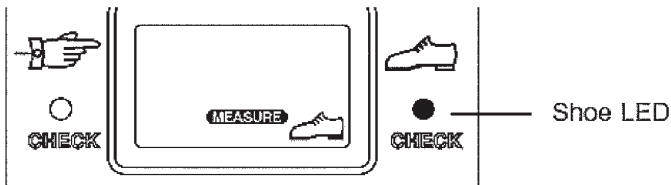

5. Testing finished in about a second, and the results are displayed as follows:
 - **HOLD** and  symbol appear on the LCD.
 - The measured value appears on the LCD, and one of the result LEDs lights according to the test result (comparison of measured value and thresholds).
 - The shoe LED lights either green or red according to the test result:
 - When the test result is OK, the LED lights green.
 - When the test result is HIGH or LOW, the LED lights red.
6. When the test is finished, the results are displayed for about ten seconds. Afterwards, if running on batteries, the power turns off. If running on the AC adapter, the power saver activates the stand-by state.

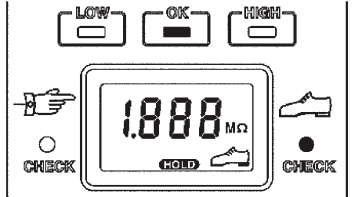

Important Notes:

- The high end of the measurement range of the Shoes and Wrist Strap Tester 747 is 200.0 MΩ. If the measured value exceeds this limit, "O.F." is displayed on the LCD.
- If the finger is removed from the touch panel during a test (while **MEASURE** appears on the LCD), or if pressure is too light on the touch panel, "Err.1" appears on the LCD. In this case, repeat the test.
- If a test is performed while the wrist strap cable is connected to the front panel, the wrist strap is automatically selected for measurement.

3.2 ESD Wrist Strap Testing with the 3M™ Shoes and Wrist Strap Tester 747

Important Note: Use single-conductor wrist straps only.

This procedure tests the effectiveness of an ESD protective wrist strap, and displays the actual measured resistance value along with the qualitative test result.

1. Select the required threshold resistance values. Refer to Section 2.2, "Threshold Resistance Settings (2)."
2. Connect the wrist strap cable to the connector on the front panel.
3. Press the center of the touch panel with your finger. Continue pressing the touch panel until measurement is completed (until the **MEASURE** indicator goes out). Testing starts and the following indicators are displayed:
 - **MEASURE** and  symbol appear on the LCD.
 - The wrist strap LED lights yellow.

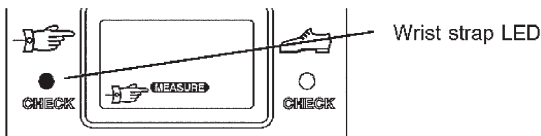

4. Testing finished in about a second, and the results are displayed as follows:

- **HOLD** and  symbol appears on the LCD.
- The measured value appears on the LCD, and one of the result LEDs lights according to the test result (comparison of measured value and thresholds).
- The wrist strap LED lights either green or red according to the test result:
- When the test result is OK, the LED lights green.
- When the test result is HIGH or LOW, the LED lights red.

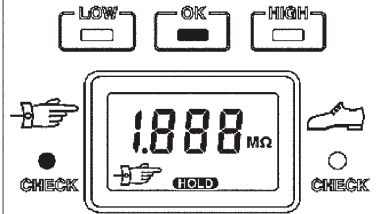

5. When the test is finished, the results are displayed for about ten seconds.

Afterwards, if running on batteries, the power turns off. If running on the AC adapter, the power saver activates the stand-by state.

Important Notes:

- The high end of the measurement range of the 3M™ Shoes and Wrist Strap Tester 747 is 200.0 MΩ. If the measured value exceeds this limit, "O.F." is displayed on the LCD.
- If the finger is removed from the touch panel during a test (while **MEASURE** appears on the LCD), or if pressure is too light on the touch panel, "Err.1" appears on the LCD. In this case, repeat the test.
- Wrist strap testing can be done even when the shoe testing cable and plate are connected.

4.0 External Output Function

4.1 Open Collector Output

Important Note: Always turn the power switch off the Shoes and Wrist Strap Tester 747 when making connections. To avoid damage to the Shoes and Wrist Strap Tester 747, do not apply more than the rated voltage and current of the OUTPUT connector.

Test results are available at the OUTPUT connector. By providing external power, a relay or sequencer can be controlled, for example, to open and close an automatic door.

After a measurement, if the test result is OK, the transistor controlling the open-collector output will turn on for 400 ms.

The output transistor functions as a switch between the output signal and internal ground. When the test result is OK, current flows from the output terminal to the internal ground.

Test Result Output Terminal

Mating Plug (stereo mini-phone)

Mating Plug Size:

14 mm by 13.5 mm diameter

Open Collector Output Ratings

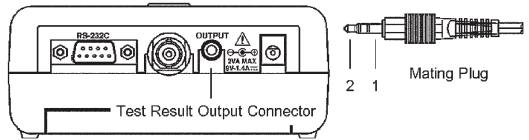

Internal Circuit

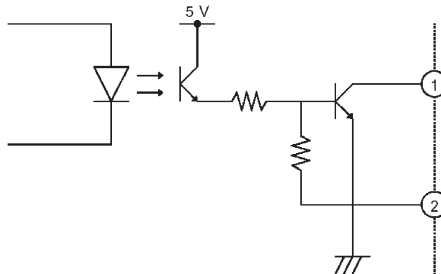

Important Note:

Mating plus not included. Please ensure that the plus used is of the type indicated above.

Test Result Output Settings

Using tweezers, select the test result type to be provided at the OUTPUT jack using the SIGNAL OUT switch on the side of the 3M™ Shoes and Wrist Strap Tester 747.

ALL: Results of both shoe and wrist strap tests are output.

WRIST: Only wrist strap test results are output.

SHOES: Only shoe test results are output.

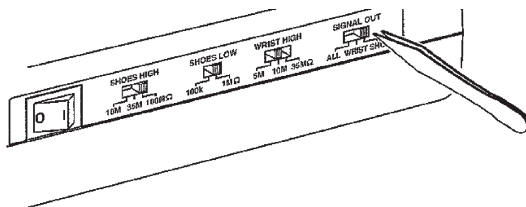

The OUTPUT terminal transistor will not turn on unless the SIGNAL OUT switch setting corresponds with the type of actual test performed, even if the result of that test is OK.

Open-Collector Output

- When the SIGNAL OUT switch is set to ALL:
The output transistor switches on when the results of the shoe and wrist strap test are OK. When making alternating shoe/wrist strap tests, the type of test to be conducted next is indicated by the blinking symbol on the LCD and the blinking LED.
- When the SIGNAL OUT switch is set to WRIST:
The output transistor is on when the result of a wrist strap test is OK.
- When the SIGNAL OUT switch is set to SHOES:
The output transistor is on when the result of a shoe test is OK.

Shoe and Wrist Strap (ALL) Setting

- If you attempt to test while the wrist strap LED is blinking and without having the wrist strap connected to the Shoes and Wrist Strap Tester 747, “Err.2” appears on the LCD. In this case, connect the wrist strap cable to the front panel connector and test again.
- Conducting a wrist strap test followed immediately by a shoe test allows the shoe test to be performed while the wrist strap remains connected to the front panel when testing one shoe only.

Important Note:

Using the 3M™ Software 747DLS with the 3M™ Shoes and Wrist Strap Tester 747 requires the following action: When testing a wrist strap and two shoes, the wrist strap ground cord must be disconnected from the Shoes and Wrist Strap Tester 747 after testing the wrist strap to perform the shoes test.

- If more than ten seconds elapse between a shoe test and a wrist strap test, the automatic power-off function clears the last test results. In this case, repeat the last test.

4.2 RS-232C Communications



CAUTION

To reduce the risks associated with hazardous voltage, which, if not avoided, may result in minor or moderate injury and/or property damage:

- Always replace battery cover before using the 3M™ Shoes and Wrist Strap Tester.

Important Notes:

- Always turn the power switch off when making connections. To avoid damage to the Shoes and Wrist Strap Tester 747, do not apply more than the rated voltage and current to the OUTPUT connector.
- To avoid damage to the unit, do not short or input voltage to the RS-232C terminal.
- When connecting the RS-232C cable, always secure with the thumb screws.
- To use the communication function, the unit must be operating with the AC adapter connected.
- In order to avoid electric shock, turn off the power to all devices before plugging in or unplugging any of the interface connectors.

Test results can be transferred to a PC by RS-232C communications. Communications can begin when the Shoes and Wrist Strap Tester 747 is operating or in stand-by state. To activate the stand-by state, place a finger on the touch panel while turning the power switch on, then wait ten seconds.

Specifications

The RS232-C settings of the Shoes and Wrist Strap Tester 747 are as follows. These setting cannot be changed, so the serial port settings on the PC must be set to match.

Transmission speed	4800 bps
Data length	8 bits
Stop bits	1 bit
Parity bit	None
Handshaking	None (no X-flow or hardware)
Delimiters	Receive: CR+LF, CP. Transmit: CR+LF
Connector	9-pin D-sub male, accepts M2.6 screws

PC Connection

The RS-232C signal wires used are as follows (no other lines are used).

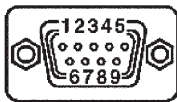

Pin	Signal	I/O	Description
2	RxD	IN	Receiving Data
3	TxD	OUT	Sending Data
5	GND	GND	Signal Ground

Other pins are not used.

Cable Connections

The 3M™ Shoes and Wrist Strap Tester 747 connects to the PC through a crossover cable. The transmit and receive lines are crossed, and the ground lines connect together. The other lines are ignored, but hardware flow control must be disabled at the PC side.

Cable wiring at Shoes and Wrist Strap Tester 747 end: cross-connected

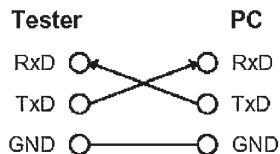

4.3 Card Reader Technical Specifications

Serial Interface Specification:

Bit Rate:

110, 300, 1200, 2400, 4800, 9600, 19200, 38400, 57600, 115200 (selectable)

Word Length:

Data Format – 4, 5, 6, 7, 8 (selectable)

Parity Bit – Even, Off, None, Mark, Space (selectable)

Stop Bit – 1, 1.5, 2 (selectable)

Handshaking (Flow Control):

None, Xon/Xoff, RTS/CTS, RTS/XonXoff (selectable)

Proximity Card Reader:

Message Indicator

Start of Text – Single ASCII Character

End of Text and CR – Single ASCII character

4.4 PC System Requirements

Check with 3M as PC System requirements and Software compatibility may differ as new Operating Systems change.

5.0 Specifications

5.1 Measurement Section

The measurement resistance range is automatically selected from the following according to the actual measured value. The resistance range cannot be set manually.

Measurement Resistance Range (0 to 200.0 M Ω)

2-M Ω Range	Max. display value: 2.000 M Ω (0.001 - M Ω resolution)
20-M Ω Range	Max. display value: 20.00 M Ω (0.01 - M Ω resolution)
200-M Ω Range	Max. display value: 200.0 M Ω (0.1 - M Ω resolution)

Testing Thresholds

Shoes Test	Lower Threshold resistance: 100 k Ω or 1 M Ω Upper Threshold resistance: 10, 35 or 100 M Ω
Wrist Strap Test	Lower Threshold resistance: 0.65 M Ω Upper Threshold resistance: 15, 10 or 35 M Ω

rdg. (displayed or indicated value)

This signifies the value actually being measured, i.e., the value that is currently indicated or displayed by the measuring instrument.

dgt. (resolution)

Signifies the smallest display unit on a digital measuring instrument, i.e., the value displayed when the last digit on the digital display is "1."

5.2 General Specifications for the 3M™ Shoes and Wrist Strap Tester 747

Ambient Operating Conditions	The unit should always be operated indoors, max. 6.562' (2000 m) height
Ambient Storage Conditions	Do not store or use the unit where it will be exposed to direct sunlight, high temperatures, high humidity or condensation. If exposed to such conditions, the unit may be damaged, the insulation may deteriorate, and the unit may no longer satisfy its specifications.
Power Supply	“AA,” LR6 alkaline battery x 6 (1.5VDC) AC adapter. Input: 100 - 250VAC; Output: 9VDC @ 1.4 A rated load; Output plug dimensions: 4.8 mm O.D. x 1.7 mm I.D. x 9.5 mm Length Output plug polarization: center positive AC adapter must have all local required regulatory certifications
Interface	RS-232C and open collector output
External Jack	Three select qualitative testing thresholds, and one selects the test type results to be available at the OUTPUT jack
Selection Switches	Threshold resistance selection switch x 3 Test result output selection switch x 1
Accessories	AC adapter ESD shoe testing cord Wall-mounting board Instruction manual, CD ESD shoe testing plate Mounting screw for ESD shoe testing plate (with washer) Alkaline battery x 6

6.0 Maintenance & Service

6.1 Battery Replacement Indicator



CAUTION

To reduce the risks associated with hazardous voltage, which, if not avoided, may result in minor or moderate injury and/or property damage:

- When replacing batteries, turn the power switch off and disconnect all the cables before beginning.
- Always replace battery cover before using the 3M™ Shoes and Wrist Strap Tester 747.

Important Notes:

- Remove the batteries before storage to prevent possible corrosion cause by battery leakage if the Shoes and Wrist Strap Tester 747 will not be used for a long period of time.
- When using the AC adapter, remove the batteries from the Shoes and Wrist Strap Tester 747 to prevent corrosion due to possible electrolyte leakage.
- When replacing the batteries, do not install old batteries with new ones, and do not mix different types of batteries. Check the battery polarity carefully when inserting the batteries.
- Keep used batteries out of the reach of children. Dispose of used batteries according to their type in the prescribed manner and in the proper location.

When the battery symbol () appears on the LCD, replace the batteries. Refer to Section 2.3.1 “Installing and Replacing the Batteries.”

6.2 Error Messages

The LCD can display the following error messages:

Error Message	Meaning	Solution
Err.1	Finger removed from touch panel during measurement	Repeat the test
Err.2	Actual test type does not match specified test type	Check test type (location), and repeat the test
O.F.	Measured value exceeded 200.0 MΩ (Overflow)	Check test type and connections, and repeat the test

6.3 Before Returning the 3M™ Shoes and Wrist Strap Tester 747 for Service



CAUTION

To reduce the risks associated with hazardous voltage, which, if not avoided, may result in minor or moderate injury and/or property damage:

- Not intended to be serviced by the user. No used serviceable parts.

Problem	Items to check
Measurement does not start when pressing the touch panel	<ul style="list-style-type: none"> Are the batteries depleted? Is the AC adapter connected? (Sec. 2.3.2) Is the power switch on? (Sec. 2.4)
Abnormal measurement values	Is the shoe testing plate connected? (Sec. 2.1)
Abnormal test results	Are the threshold resistance switch selections correct? (Sec. 2.2)
Test results not available at OUTPUT terminal	Is the SIGNAL OUT switch selection correct? (Sec. 4.1)
RS-232C communication inoperable	<ul style="list-style-type: none"> Is the 3M™ Shoes and Wrist Strap Tester 747 running on the AC adapter? (Sec. 2.3.2) Are the serial communications settings correct? (Sec. 4.2) Is a crossed cable being used for the connection? (Sec. 4.2)

6.4 Cleaning

Gently wipe dirt from the surface of the unit with a soft cloth moistened with a small amount of water or mild detergent.

7.0 Operational Verification Test



CAUTION

To reduce the risks associated with hazardous voltage, which, if not avoided, may result in minor or moderate injury and/or property damage:

- Not intended to be serviced by the user. No user serviceable parts.

To reduce the risks associated with electrostatic discharge (ESD), which, if not avoided, may result in property damage to electronic components or assemblies being handled:

- Perform operational verification test to ensure proper operations of the 3M™ Shoes and Wrist Strap tester 747 as required.

Testing Considerations

- This test procedure is used to verify that the 3M™ Shoes and Wrist Strap Tester 747 functions within the specifications as stated in Chapter 5 of this instruction manual. It is recommended that you become familiar with the operation of the Shoes and Wrist Strap Tester 747 outlined in this manual, before beginning testing.
- It is recommended that this procedure be performed annually. However, if the unit is exposed to a harsh environment or has been abused in some manner, it may require performing this test procedure more frequently.

Equipment Required

- Resistance Substitution Box (RSB) – 630 K Ω to 103 M Ω (minimum range) \pm 1% or discrete resistors \pm 1%, using resistor values as indicated in the table below.
- Lead wires – As required to connect between RSB and the 3M™ Shoes and Wrist Strap Tester 747.
- 3M™ Copper Foil Tape with conductive adhesive or equivalent (4" L x 1" W recommended).

Test Set-Up

Apply a strip of copper foil tape to the unit's "Touch Panel" as shown in Fig. 1, leaving a short tab for the purpose of attachment of a test lead. To prevent the copper foil tape from curling during removal of the release liner, peel the release liner from the copper foil tape.

Testing Wrist Strap Ranges

Connect the reference resistor to the "Wrist Strap Connector" and the tab of the Copper Foil Tape on the Shoes and Wrist Strap Tester 747 as shown in Figure 1.

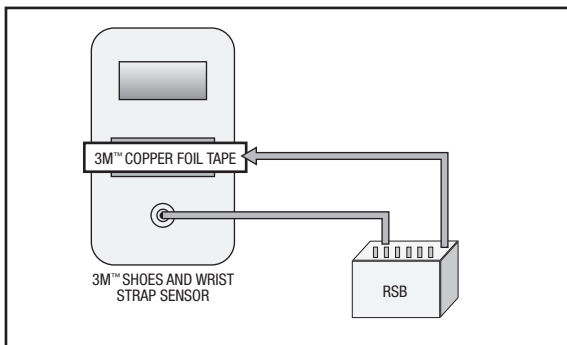

Figure 1: Wrist Strap Test Set-up

Testing Wrist Low Limit – Refer to Wrist Test Table

1. Switch on the 3M™ Shoes and Wrist Strap Tester 747.
2. Select 5 MΩ position on the “Wrist High” switch.
3. Select Wrist position on the “Signal Out” switch.
4. Set reference resistor to 630 KΩ.
5. Press down on the “Touch Panel” and observe LED indicators and value displayed on LCD comparing to Wrist Test Table below.
6. Set reference resistor to 670 KΩ.
7. Press down on the “Touch Panel” and observe LED indicators and value displayed on LCD comparing to Wrist Test Table below.

Testing Wrist High Limits – Refer to Wrist Test Table

8. Repeat test sequence using specified resistors as indicated in Wrist Test Table below for “Wrist High” 5 MΩ, 10 MΩ, and 35 MΩ positions.

Wrist Test Table

Reference Resistor	Wrist High Range Switch Setting	Wrist Strap Check LED Indicator	Test Result LED Indicator
Low Limit* ≤630 KΩ ≥670 KΩ	5 MΩ	Red Green	Low OK
High Limit ≤4.8 MΩ ≥5.2 MΩ	5 MΩ	Green Red	OK High
High Limit ≤9.7 MΩ ≥10.3 MΩ	10 MΩ	Green Red	OK High
High Limit 33.9 MΩ ≥36.1 MΩ	35 MΩ	Green Red	OK High

**Low limit value (650 KΩ) for wrist straps is set internally and cannot be adjusted.*

Testing Shoe Ranges

Connect the reference resistor to the “Shoe Plate Cable” and the tab of the 3M™ Copper Foil Tape on the 3M™ Shoes and Wrist Strap Tester 747 as show in the Figure 2.

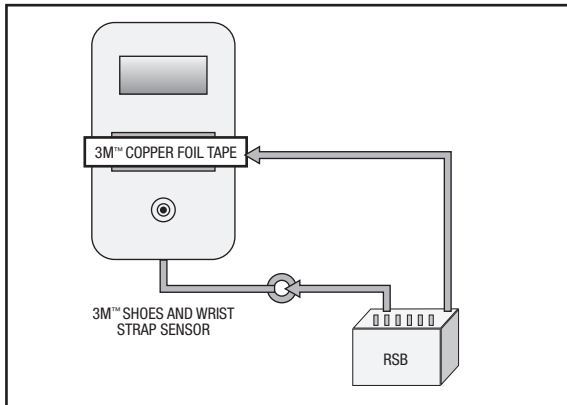

Figure 2 : Wrist Strap Test Set-Up

Testing Shoes Low Limits – Refer to Shoes Test Table

1. Select 10 M Ω position on the “Shoes High” switch.
2. Select 100 K Ω position on the “Shoes Low” switch.
3. Select Shoes position on the “Signal Out” switch.
4. Set reference resistor to 97 K Ω .
5. Press down on the “Touch Panel” and observe LED indicators and value displayed on LCD comparing to Shoes Test Table on the following page.
6. Set reference resistor to 103 K Ω .
7. Press down on the “Touch Panel” and observe LED indicators and value displayed on LCD comparing to Shoes Test Table on the following page.
8. Select 1 M Ω position on the “Shoes Low” switch.
9. Set reference resistor to 970 K Ω .
10. Press down on the “Touch Panel” and observe LED indicators and value displayed on LCD comparing to Shoes Test Table on the following page.
11. Set reference resistor to 1.03 M Ω .
12. Press down on the “Touch Panel” and observe LED indicators and value displayed on LCD comparing to Shoes Test Table on the following page.
13. Repeat test sequence using specified reference resistors as indicated in Shoes Test Table below for 10 M Ω , 35 M Ω and 100 M Ω positions.

Shoe Test Table

Reference Resistor	Wrist High Range Switch Setting	Wrist Low Range Switch Setting	Wrist Strap Check LED Indicator	Test Result LED Indicator
Low Limit* $\leq 630 \text{ K}\Omega$ $\geq 670 \text{ K}\Omega$	5 M Ω	100 K Ω	Red Green	Low OK
High Limit $\leq 4.8 \text{ M}\Omega$ $\geq 5.2 \text{ M}\Omega$	5 M Ω	1 M Ω	Green Red	OK High
High Limit $\leq 9.7 \text{ M}\Omega$ $\geq 10.3 \text{ M}\Omega$	10 M Ω	1 M Ω	Green Red	OK High
33.9 M Ω $\geq 36.1 \text{ M}\Omega$	35 M Ω	1 M Ω	Green Red	OK High

Regulatory Information

WEEE Statement

The following information is only for EU-members States: The mark shown to the right is in compliance with Waste Electrical and Electronic Equipment Directive 2002/96/EC (WEEE). The mark indicates the requirement NOT to dispose the equipment as unsorted municipal waste, but use the return and collection systems according to local law.

cULus Statement

Meets UL Safety Requirements.

CE Statement

Meets CE (European Conformity) requirements.

FCC

This equipment has been tested and found to comply with the limits for a Class B digital device, pursuant to part 15 of the FCC Rules. These limits are designed to provide reasonable protection against harmful interference in a residential installation. This equipment generates, uses and can radiate radio frequency energy and, if not installed and used in accordance with the instructions, may cause harmful interference to radio communications. However, there is no guarantee that interference will not occur in a particular installation. If this equipment does cause harmful interference to radio or television reception, which can be determined by turning the equipment off and on, the user is encouraged to try to correct the interference by one or more of the following measures:

- Reorient or relocate the receiving antenna.
 - Increase the separation between the equipment and receiver.
 - Connect the equipment into an outlet on a circuit different from that to which the receiver is connected.
 - Consult the dealer or an experienced radio/TV technician for help.
- Restriction of the use of certain hazardous substances (RoHS): Meets 2011-65-EU Directive.

To reduce the risks associated with environmental contamination from the device along with the Lithium and Alkaline battery:

- At the end of service life, dispose of the charge analyzer and batteries in accordance with federal, state and local requirements.

Per the European Battery Directive, Alkaline Batteries are not provided with the equipment and must be locally sourced

UL Listed to U.S. and Canadian Safety Standards.
Mark of Conformity to European Directives (Conformité Européene).

3M is a trademark of 3M Company.

Important Notice

All statements, technical information, and recommendations related to 3M's products are based on information believed to be reliable, but the accuracy or completeness is not guaranteed. Before using this product, you must evaluate it and determine if it is suitable for your intended application. You assume all risks and liability associated with such use. Any statements related to the product which are not contained in 3M's current publications, or any contrary statements contained on your purchase order shall have no force or effect unless expressly agreed upon, in writing, by an authorized officer of 3M.

Warranty; Limited Remedy; Limited Liability.

This product will be free from defects in material and manufacture for one year from the time of purchase. **3M MAKES NO OTHER WARRANTIES INCLUDING, BUT NOT LIMITED TO, ANY IMPLIED WARRANTY OF MERCHANTABILITY OR FITNESS FOR A PARTICULAR PURPOSE.** If this product is defective within the warranty period stated above, your exclusive remedy shall be, at 3M's option, to replace or repair the 3M product or refund the purchase price of the 3M product. **Except where prohibited by law, 3M will not be liable for any indirect, special, incidental or consequential loss or damage arising from this 3M product, regardless of the legal theory asserted.**

3M

Electronic Solutions Division Static Control Products

926 JR Industrial Drive
Sanford, NC 27332-9733
Toll-Free: 866-722-3736
International: 919-718-0000
Email: 3mstaticinfo@mmm.com
www.3mstatic.com



Please recycle. Printed in USA.
© 3M 2014. All rights reserved.
78-8132-1190-7B JHA

Free Manuals Download Website

<http://myh66.com>

<http://usermanuals.us>

<http://www.somanuals.com>

<http://www.4manuals.cc>

<http://www.manual-lib.com>

<http://www.404manual.com>

<http://www.luxmanual.com>

<http://aubethermostatmanual.com>

Golf course search by state

<http://golfingnear.com>

Email search by domain

<http://emailbydomain.com>

Auto manuals search

<http://auto.somanuals.com>

TV manuals search

<http://tv.somanuals.com>