



Instructions and Parts List

3M-MaticTM

800a Type 40800

Adjustable Case Sealer

with

AccuGlideTM 3 Taping Heads

Serial No. _____
For reference, record machine serial number here.



3M Industrial Adhesives and Tapes
3M Center, Building 220-5E-06
St. Paul, MN 55144-1000



Important Safety Information

BEFORE INSTALLING
OR OPERATING THIS
EQUIPMENT

Read, understand, and
follow all safety and
operating instructions.

Spare Parts

It is recommended you
immediately order the
spare parts listed in the
"Spare Parts/Service
Information" section.

These parts are expected
to wear through normal
use, and should be kept
on hand to minimize
production delays.

"3M-Matic" and "AccuGlide" are Trademarks of,
3M St. Paul, MN 55144-1000
Printed in U.S.A.

© 3M 2011 44-0009-2080-9 (A082611-NA)



This instruction manual covers safety aspects, handling and transport, storage, unpacking, preparation, installation, operation, adjustments, maintenance, troubleshooting, repair work and servicing plus parts list of the **3M-Matic™ 800a** adjustable case sealer.

3M Industrial Adhesives and Tapes
3M Center, Building 220-5E-06
St. Paul, MN 55144-1000

Edition August 2011

Copyright 3M 2011
All rights reserved

The manufacturer reserves the right to change the product at any time without notice.

Replacement Parts and Service Information

To Our Customers:



This is the 3M-Matic™/AccuGlide™/Scotch® equipment you ordered. It has been set up and tested in the factory with Scotch® tapes. If technical assistance or replacement parts are needed, call or fax the appropriate number listed below.

Included with each machine is an Instructions and Parts List manual.

Technical Assistance / Replacement Parts and Additional Manuals:

Contact your local service provider. Provide the customer support coordinator with the model/machine name, machine type, and serial number that are located on the identification plate (For example: Model 800a - Type 40800 - Serial Number 13282).

Identification Plate

	3M Company St. Paul, MN 55144 USA	Part Number <input type="text"/>	3M-Matic™ For Commercial Use Only		
Model <input type="text"/>		Serial Number <input type="text"/>	Year <input type="text"/>	Ampere <input type="text"/>	Watt <input type="text"/>
Type <input type="text"/>			Volt <input type="text"/>	Hertz <input type="text"/>	Phase <input type="text"/>

Minimum billing on parts orders will be \$25.00. Replacement part prices available on request.
\$10.00 restocking charge per invoice on returned parts



3M Industrial Adhesives and Tapes

3M Center, Building 220-5E-06
St. Paul, MN 55144-1000

3M-Matic™, AccuGlide™ and Scotch™ are
Trademarks of
3M St. Paul, MN 55144-1000
Printed in U.S.A.

THIS PAGE IS BLANK

Replacement Parts And Service Information

To Our Customers:

This is the 3M-Matic™/AccuGlide™/Scotch® equipment you ordered. It has been set up and tested in the factory with Scotch® tapes. If any problems occur when operating this equipment and you desire a service call or phone consultation, call, write, or fax the appropriate number listed below.

Included with each machine is an Instructions and Parts List manual.

SERVICE, REPLACEMENT PARTS, AND ADDITIONAL MANUALS

AVAILABLE DIRECT FROM:

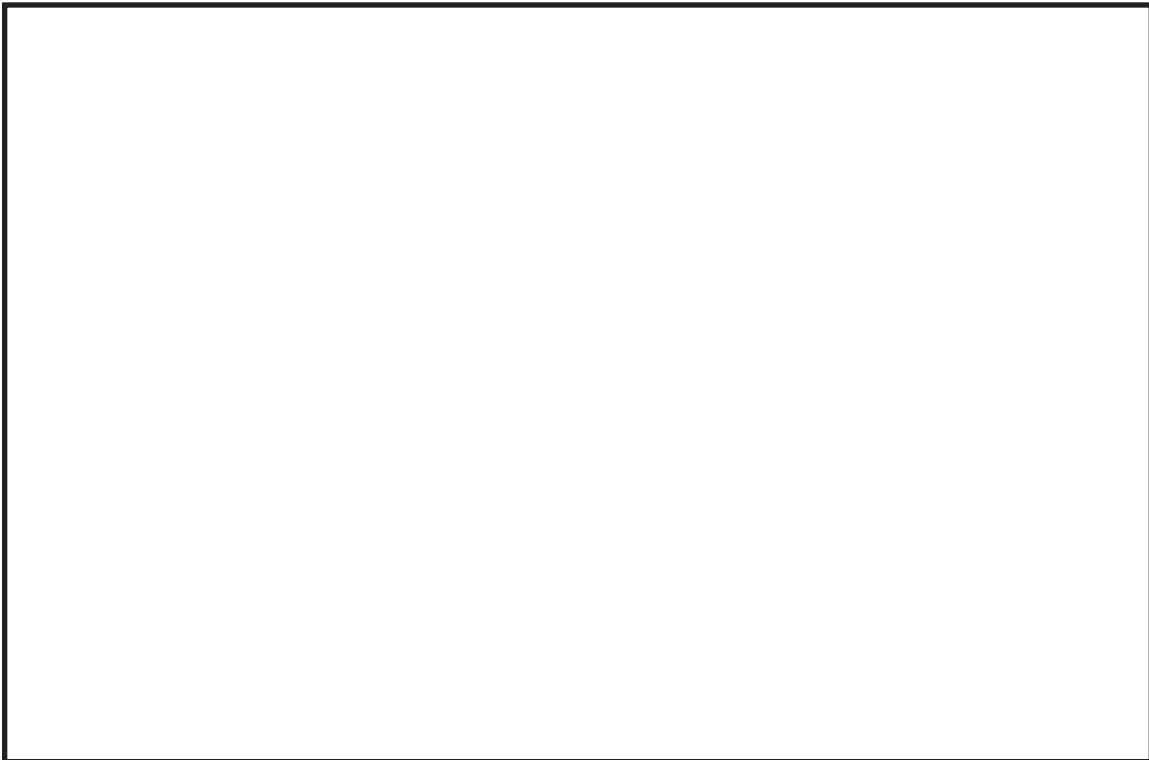

Order parts by part number, part description, and quantity required. Also, when ordering parts or additional manuals, include model/machine name, machine type, and serial number that are located on the identification plate.



3M Industrial Adhesives and Tapes

3M Center, Building 220-5E-06
St. Paul, MN 55144-1000

3M-Matic™, AccuGlide™ and Scotch™ are
Trademarks of
3M, St. Paul, MN 55144-1000
Printed in U.S.A.

THIS PAGE IS BLANK

TABLE OF CONTENTS - MANUAL 1: 800a Adjustable Case Sealer
(For Taping Head Information - See MANUAL 2: AccuGlide™ 3 Taping Heads - 2 inch)

800a Adjustable Case Sealer	Page
Cover Page	
Replacement Parts and Service Information	i - ii
Table of Contents	iii - v
Acronyms and Abbreviations	vi
1. Introduction	
1.1 Manufacturing Specifications / Description / Intended Use	1 - 2
1.2 How to Read and Use the Manual	2
1.2.1 Importance of the Manual	2
1.2.2 Manual Maintenance	2
1.2.3 Consulting the Manual	2
1.2.4 How to Update the Manual in Case of Modifications	2
2. General Information	
2.1 Identification Data	3
2.2 After-Sale Service	3
2.3 Warranty / Contents	4
3. Safety	
3.1 General Safety Information	5
3.2 Signal Words Explanation	5
3.3 Table of Warnings	6 - 7
3.4 Operator's Qualifications Definition	8
3.5 Number of Operators	8
3.6 Safe Use of the Machine Instructions	8
3.7 Residual Hazards	8
3.8 Prevent Other Hazards - Recommendations and Measures	8
3.9 Personal Safety Measures	8
3.10 Incorrect / Predictable Actions Not Allowed	8
3.11 Operator's Required Skill Levels	9
3.12 Component Locations	10
3.13 Table of Warnings and Replacement Labels	11
4. Technical Specifications	
4.1 Power Requirements	12
4.2 Operating Rate	12
4.3 Operating Conditions	12
4.4 Tape	12
4.5 Tape Width	12
4.6 Tape Roll Diameter	13
4.7 Tape Application Leg Length - Standard	13
Tape Application Leg Length - Optional	
4.8 Box Board	13
4.9 Box Weight and Size Capacities	13
4.10 Machine Noise Levels	14
4.11 Machine Dimensions	14
4.12 Set-Up Recommendations	14

THIS PAGE IS BLANK

TABLE OF CONTENTS (continued)

5. Shipment, Handling, and Storage

5.1 Packed Machine Shipment and Handling	15
5.2 Overseas Shipment Packaging (Optional)	15
5.3 Handling and Transportation of Uncrated Machine	15
5.4 Machine Storage	15

6. Unpacking

6.1 Uncrating	16
6.2 Packaging Materials Disposal	16

7. Installation

7.1 Operating Conditions	17
7.2 Space Requirements for Machine Operation and Maintenance	17
7.3 Tool Kit Supplied with the Machine	17
7.4 Machine Positioning / Machine Set-Up	17
7.5 Plastic Ties Removal	18
7.6 Assembly Completion	18
7.7 Taping Heads Completion	19
7.8 Outboard Tape Roll Holder	19
7.9 Preliminary Electric Inspection	19
7.10 Main Power Machine Connection and Inspection	19
7.11 Phases Inspection	19

8. Theory of Operation

8.1 Working Cycle Description	20
8.2 Running Mode Definition	20
8.3.1 Normal Stop Procedure	20
8.3.2 Emergency Stop	20

9. Controls

9.1 Box Width Adjusting Knobs	21
9.2 Box Height Adjusting Crank	21
9.3 Start / Stop Main Switch	21
9.4 Emergency Stop Button (Latching)	21

10. Safety devices

10.1 Blade Guards	22
10.2 Emergency Stop Button	22
10.3 Electric System / Circuit Breaker	22

11. Set-Up and Adjustments

11.1 Box Width Adjustment	23
11.2 Box Height Adjustment	23
11.3 Top Flap Compression Roller Adjustment	23
11.4 Changing the Tape Leg Length	23
11.5 Run Boxes to Check Adjustment	23

THIS PAGE IS BLANK

TABLE OF CONTENTS (continued)

12. Operation

12.1 Operator's Correct Working Position 24
12.2 Starting the Machine 24
12.3 Starting Production 24
12.4 Tape Replacement 24
12.5 Box Size Adjustment 24
12.6 Cleaning 24
12.7 Table of Adjustments 24
12.8 Safety Devices Inspection 24
12.9 Trouble Shooting 25

13. Maintenance

13.1 Safety Measures (see section 3) 26
13.2 Tools and Spare Parts Supplied with Machine 26
13.3 Maintenance Operations - Recommended Inspections and Frequency 26
13.4 Inspections to be Performed Before and After Every Maintenance Operation 26
13.5 Safety Features (Inspection Efficiency) 26
13.6 Machine Cleaning 26
13.7 Cutter Blade Cleaning 26
13.8 Drive Belt Replacement 27 - 29
13.9 Drive Pulley Ring 28
13.10 Drive Belt Tension 29
13.11. Special Set-Up Procedures 29 - 35
 13.11.1 Case Sealer Frame 29
 13.11.2 Taping Heads 30 - 31
 13.11.3 Drive Belt Assembly Height 31
 13.11.4 Box Height Range (Outer Column Repositioning) 32 - 35
13.12 Maintenance Work Log 37

14. Additional Instructions

14.1 Machine Disposal Information 39
14.2 Fire emergency 39

15. Enclosures and Special Information

15.1 Statement of Conformity 39
15.2 Hazardous Substances Emission 39

16. Technical Documentation and Information

16.1 Electric Diagrams 41
16.2 Spare Parts / Ordering 42 - 43

Drawings and Parts Lists 45 - End of Manual

**TAPING HEAD INFORMATION -
MANUAL 2: AccuGlide™ 3 Taping Heads - 2 inch (See MANUAL 2 for Table of Contents)**

ABBREVIATIONS AND ACRONYMS

LIST OF ABBREVIATIONS, ACRONYMS

3M-Matic	- Trademark of 3M St. Paul, MN 55144- 1000
AccuGlide	- Trademark of 3M St. Paul, MN 55144-1000
Scotch	- Trademark of 3M St. Paul, MN 55144-1000
Drw.	- drawing
Ex.	- for example
Fig.	- exploded view figure no. (spare parts)
Figure	- Illustration
Max.	- maximum
Min.	- minimum
Nr.	- number
N/A	- not applicable
OFF	- machine not operating
ON	- machine operating
PLC	- Programmable Logic Control
PP	- Polypropylene
PTFE	- Polytetraflourethelene
PU/PU Foam	- Polyurethane Foam
PVC	- Poly-vinyl chloride
W	- Width
H	- Height
L	- Length

1-INTRODUCTION

1.1 Manufacturing Specifications / Description / Intended Use

The **3M-Matic™ 800a Adjustable Case Sealer with AccuGlide™ 3** Taping Heads is designed to apply a “C” clip of **Scotch®** pressure-sensitive film box sealing tape to the top and bottom center seam of regular slotted containers. The 800a is manually adjustable to a wide range of box sizes (see "Specifications Section – Box Weight and Size Capacities").

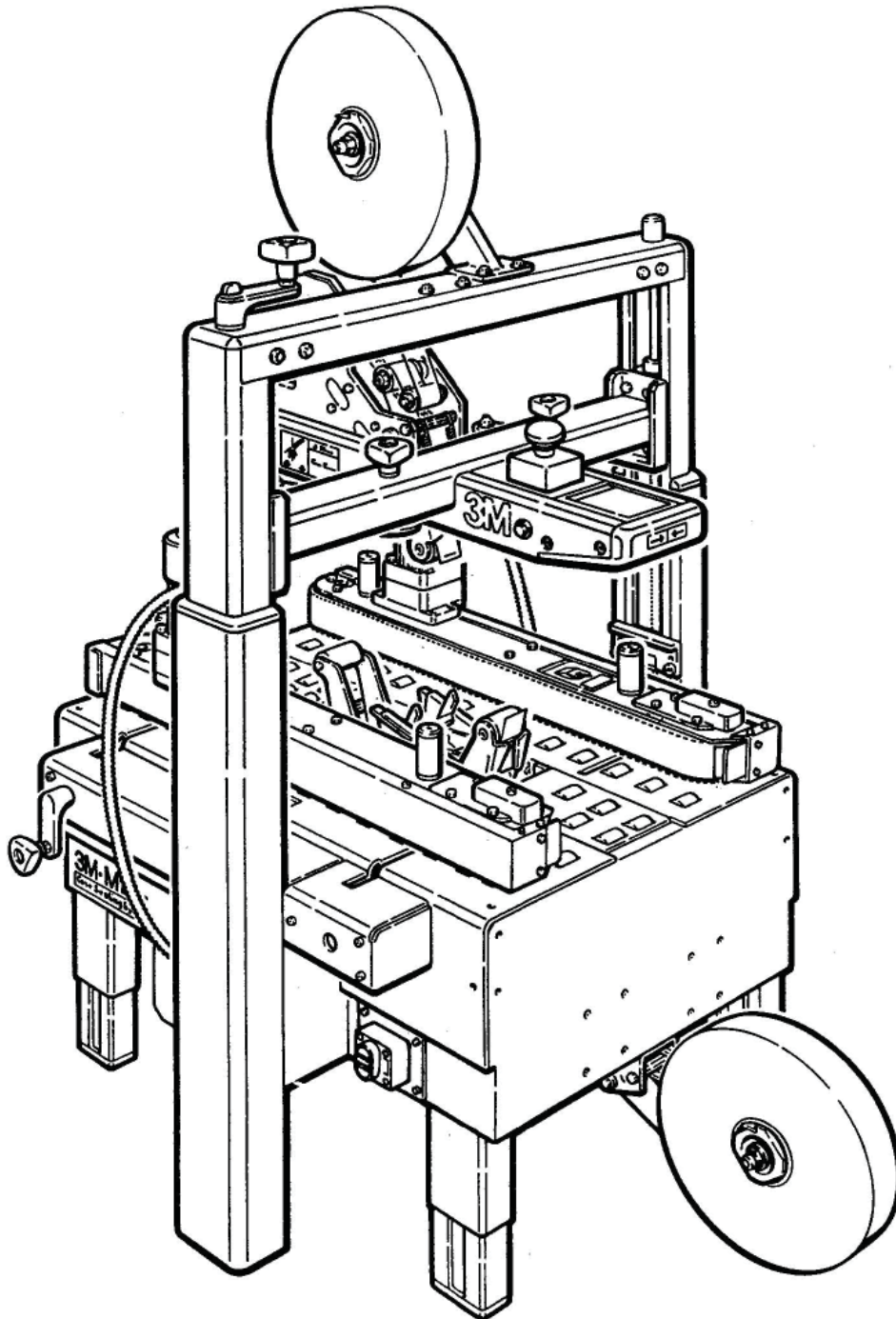

3M-Matic™ 800a Adjustable Case Sealer, Type 40800

Note – Shown above is the lower tape supply roll and bracket assembly in the alternate location.

1.1 Manufacturing Specifications / Description / Intended Use (continued)

The 3M-Matic™ case sealing machines have been designed and manufactured in compliance with the legal requirements at the date of inception.

1.2 How to Read and Use the Instruction Manual

This instruction manual covers safety aspects, handling and transport, storage, unpacking, preparation, installation, operation, set-up and adjustments, technical and manufacturing specifications, maintenance, troubleshooting, repair work and servicing, electric diagrams, warranty information, disposal (ELV), a definition of symbols, plus a parts list of the 3M-Matic™ 800a Adjustable case sealer 3M Industrial Adhesives and Tapes Division 3M Center, Bldg. 220-5E-06 St. Paul, MN 55144-1000 (USA) Edition August 2011 Copyright 3M 2011 All rights reserved. The manufacturer reserves the right to change the product at any time without notice Publication © **3M 2011 44-0009-2080-9.**

1.2.1 Importance of the Manual

The manual is an important part of the machine; all information contained herein is intended to enable the equipment to be maintained in perfect condition and operated safely. Ensure that the manual is available to all operators of this equipment and is kept up to date with all subsequent amendments. Should the equipment be sold or disposed of, please ensure that the manual is passed on. Electrical and pneumatic diagrams are included in the manual. Equipment using PLC controls and/or electronic components will include relevant schematics or programs in the enclosure and in addition, the relevant documentation will be delivered separately.

1.2.2 Manual Maintenance

Keep the manual in a clean and dry place near the machine. Do not remove, tear, or rewrite parts of the manual for any reason. Use the manual without damaging it. In case the manual has been lost or damaged, ask your after sale service for a new copy.

1.2.3 Consulting the Manual

The manual is composed of:

- Pages which identify the document and the machine
- Index of the subjects
- Instructions and notes on the machine
- Enclosures, drawings and diagrams
- Spare parts (last section)

All pages and diagrams are numbered. The spare parts lists are identified by the figure identification number. All the notes on safety measures or possible dangers are identified by the symbol:



1.2.4 How to Update the Manual in Case of Modifications to the Machine

Modifications to the machine are subject to manufacturer's internal procedures. The user receives a complete and up-to-date copy of the manual together with the machine. Afterwards the user may receive pages or parts of the manual which contain amendments or improvements made after its first publication. The user must use them to update this manual.

2-GENERAL INFORMATION

2.1 Data Identifying Manufacturer and Machine

3M 3M Industrial Adhesives and Tapes 3M Center Bldg. 220-5E-06 St. Paul, MN 55144-1000 (USA)

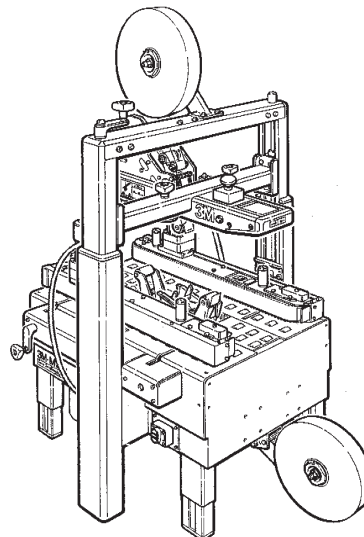

3M 3M Company St. Paul, MN 55144 USA	Part Number <input type="text"/>	3M-Matic™ For Commercial Use Only	 4000 668	
Model <input type="text"/>	Serial Number <input type="text"/>	Year <input type="text"/>	Amps <input type="text"/>	Watt <input type="text"/>
Type <input type="text"/>		Volt <input type="text"/>	Hertz <input type="text"/>	Phase <input type="text"/>

2.2 Data for Technical Assistance and Service

<p>AGENT/DISTRIBUTOR OR LOCAL AFTER SALE SERVICE:</p>
--

2.3 Warranty

Equipment Warranty and Limited Remedy: THE FOLLOWING WARRANTY IS MADE IN LIEU OF ALL OTHER WARRANTIES, EXPRESS OR IMPLIED, INCLUDING, BUT NOT LIMITED TO, THE IMPLIED WARRANTY OF MERCHANTABILITY, THE IMPLIED WARRANTY OF FITNESS FOR A PARTICULAR PURPOSE AND ANY IMPLIED WARRANTY ARISING OUT OF A COURSE OF DEALING, A CUSTOM OR USAGE OF TRADE:

3M sells its **3M-Matic™ 800a Adjustable Case Sealer, Type 40800** with the following warranties:

1. The drive belts and the taping head knives, springs and rollers will be free from all defects for ninety (90) days after delivery.
2. All other taping head parts will be free from all defects for three (3) years after delivery.
3. All other parts will be free from all defects for two (2) years after delivery.

If any part is proved to be defective within its warranty period, then the exclusive remedy and 3M's and seller's sole obligation shall be, at 3M's option, to repair or replace the part, provided the defective part is returned immediately to 3M's factory or an authorized service station designated by 3M. A part will be presumed to have become defective after its warranty period unless the part is received or 3M is notified of the problem no later than five (5) calendar days after the warranty period. If 3M is unable to repair or replace the part within a reasonable time, then 3M at its option, will replace the equipment or refund the purchase price. 3M shall have no obligation to provide or pay for the labor required to install the repaired or replacement part. 3M shall have no obligation to repair or replace (1) those parts failing due to operator misuse, carelessness, or due to any accidental cause other than equipment failure, or (2) parts failing due to non-lubrication, inadequate cleaning, improper operating environment, improper utilities or operator error.

Limitation of Liability: 3M and seller shall not be liable for direct, indirect, special, incidental or consequential damages based upon breach of warranty, breach of contract, negligence, strict liability or any other legal theory.

The foregoing Equipment Warranty and Limited Remedy and Limitation of Liability may be changed only by a written agreement signed by authorized officers of 3M and seller.

Contents—800a Adjustable Case Sealer

- (1) 800a Adjustable Case Sealer, Type 40800
- (1) Upper Assembly Height Adjustment Crank Hardware
- (1) Tool and Spare Parts Kit
- (1) Instruction and Parts Manual

3-SAFETY

3.1 General Safety Information

Read all the instructions carefully before starting work with the machine; please pay particular attention to sections marked by the symbol:



Figure 3-1

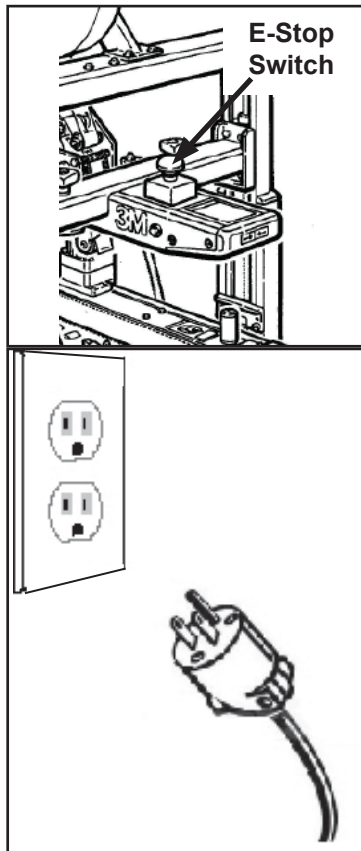

3.2 Explanation of Signal Word and Possible Consequences



This safety alert symbol identifies important messages in this manual. **READ AND UNDERSTAND THEM BEFORE INSTALLING OR OPERATING THIS EQUIPMENT.**



CAUTION: Indicates a potentially hazardous situation, which, if not avoided, may result in minor or moderate injury and/or property damage.





WARNING: Indicates a potentially hazardous situation, which, if not avoided, could result in death or serious injury and/or property damage.

The machine is provided with a LATCHING EMERGENCY STOP BUTTON (**Figure 3-1**); when this button is pressed, it stops the machine at any point in the working cycle. Maintain clear access to power cord while machine is operating. Disconnect plug from power source before machine maintenance (**Figure 3-1**). Also disconnect air if the machine has a pneumatic system. Keep this manual in a handy place near the machine. This manual contains information that will help you to maintain the machine in a good and safe working condition.

3.3 Table of Warnings

 WARNING
<ul style="list-style-type: none"> • To reduce the risk associated with mechanical and electrical hazards: <ul style="list-style-type: none"> – Read, understand, and follow all safety and operating instructions before operating or servicing the case sealer. – Allow only properly trained and qualified personnel to operate and service this equipment.

 WARNING
<ul style="list-style-type: none"> • To reduce the risk associated with hazardous voltage: <ul style="list-style-type: none"> – Position electrical cord away from foot and vehicle traffic.

 WARNING
<ul style="list-style-type: none"> • To reduce the risk associated with pinches, entanglement and hazardous voltage: <ul style="list-style-type: none"> – Turn electrical supply off and disconnect before performing any adjustments, maintenance or servicing the machine or taping heads.

 WARNING
<ul style="list-style-type: none"> • To reduce the risk associated with pinches and entanglement hazards: <ul style="list-style-type: none"> – Do not leave the machine running while unattended. – Push the machine off when not in use. – Never attempt to work on any part of the machine, load tape, or remove jammed boxes from the machine while the machine is running.

	SAFETY INSTRUCTIONS
Figure 3-2	<ol style="list-style-type: none"> 1. Shut off machine before adjusting 2. Unplug electric power before servicing 3. Do not leave machine running unattended 4. Refer to instruction manual for complete setup, operating, and servicing information

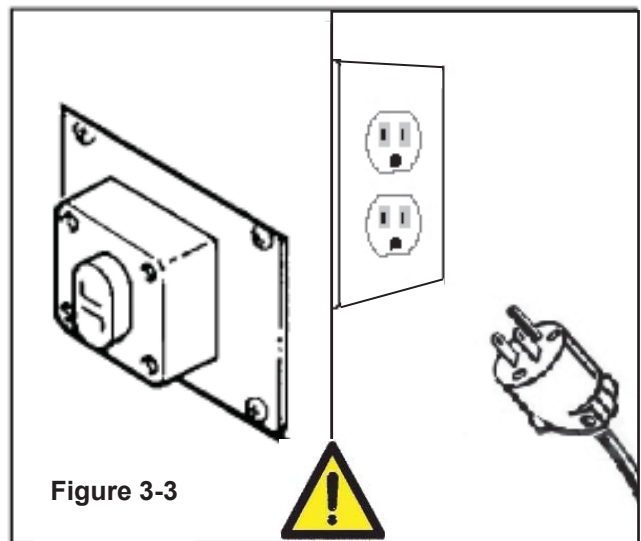

Figure 3-3

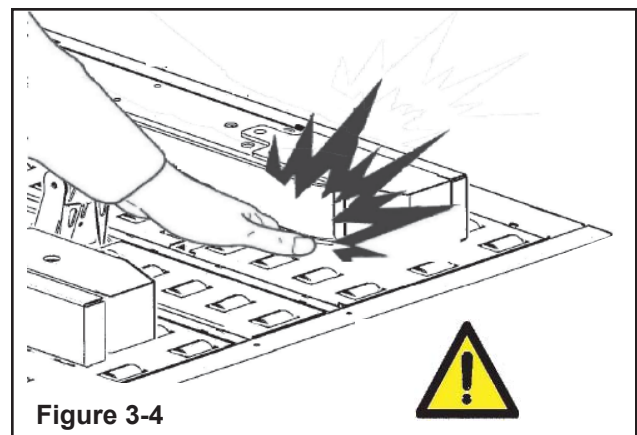

Figure 3-4

Important! Cavity in the conveyor bed. Never put your hands inside any part of the machine while it is working. Serious injury may occur (Figure 3-4).



WARNING

- **To reduce the risk associated with sharp blade hazards:**
 - Keep hands and fingers away from tape cutoff blades under orange blade guards. The blades are extremely sharp.

Important! Tape cutting blade. Never remove the safety device which covers the blade on the top and bottom taping units. Blades are extremely sharp. Any error may cause serious injuries (**Figure 3-5**).



WARNING

- **To reduce the risk associated with fire and explosion hazards:**
 - Do not operate this equipment in potentially flammable/explosive environments.



WARNING

- **To reduce the risk associated with muscle strain:**
 - Use the appropriate rigging and material handling equipment when lifting or repositioning this equipment.
 - Use proper body mechanics when removing or installing taping heads that are moderately heavy or may be considered awkward to lift.



CAUTION

- **To reduce the risk associated with pinch hazards:**
 - Keep hands clear of the upper head support assembly as boxes are transported through the machine.
 - Keep hands, hair, loose clothing, and jewelry away from box compression rollers.
 - Always feed boxes into the machine by pushing only from the end of the box.
 - Keep hands, hair, loose clothing, jewelry away from moving belts and taping heads.

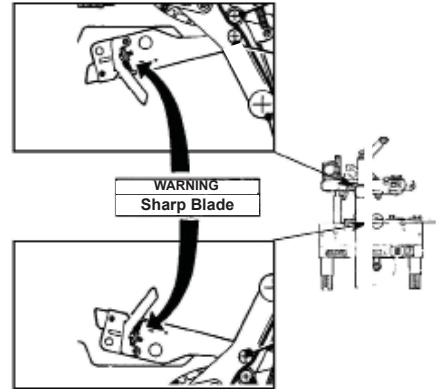

Figure 3-5

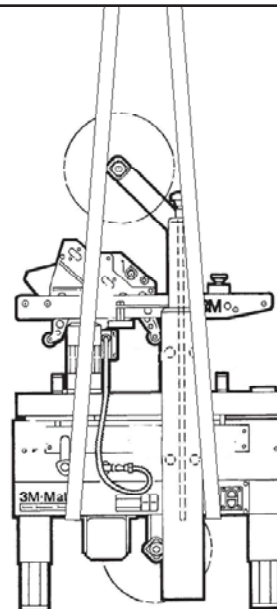

Figure 3-6

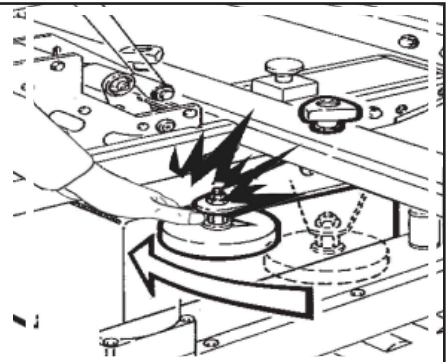

Figure 3-7

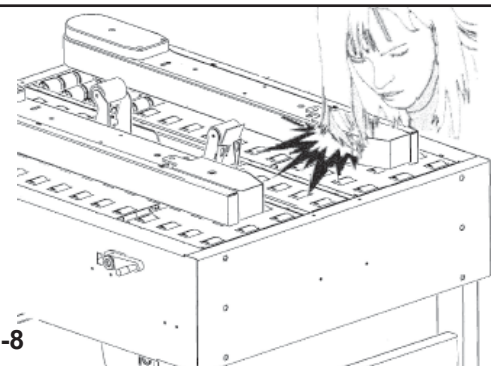

Figure 3-8

3.4 Operator's Qualifications

- Machine Operator
- Mechanical Maintenance Technician
- Electrical Maintenance Technician
- Manufacturer's Technician/Specialist
(See Section 3)

3.5 Number of Operators

The operations described below have been analyzed by the manufacturer; the recommended number of operators for each operation provides the best and safest work performance.

Note: A smaller or greater number of operators could be unsafe.

3.6 Instructions for a Safe Use of the Machine / Definition of Operator's Qualifications

Only persons who have the skills described in the skill levels section should be allowed to work on the machine. It is the responsibility of the user to appoint the operators having the appropriate skill level and the appropriate training for each category of job.

3.7 Residual Hazards

The case sealer 800a incorporates various safety protections which should never be removed or disabled. It is essential that the operator and service personnel be warned that hazards exist which cannot be eliminated.

3.8 Recommendations and Measures to Prevent Other Hazards which Cannot be Eliminated

- The operator must stay on the working position shown in the Operation Section. He must never touch the running driving belts or put his hands inside any cavity.
- The operator must pay attention to the blades during the tape replacement.



WARNING

- **To reduce the risk associated with mechanical and electrical hazards:**
 - Read, understand, and follow all safety and operating instructions before operating or servicing the case sealer.
 - Allow only properly trained and qualified personnel to operate and service this equipment.

3.9 Personal Safety Measures

Safety glasses, safety gloves, safety helmet, safety shoes, air filters, ear muffs - None is required except when recommended by the user.

3.10 Predictable Actions which are Incorrect and Not Allowed

- Never try to stop/hold the box while being driven by the belts.
- Never remove or disable the safety devices.
- Only authorized personnel should be allowed to carry out the adjustments, repairs or maintenance which require operation with reduced safety protections. During such operations, access to the machine must be restricted. When the work is finished, the safety protections must immediately be reactivated.
- The cleaning and maintenance operations must be performed after disconnecting the electric power.
- Do not modify the machine or any part of it.
- Clean the machine using only dry cloths or light detergents. Do not use solvents, petrols, etc.
- Install the machine following the suggested layouts and drawings.

3.11 Operator's Skill Levels Required to Perform the Main Operations on the Machine

The Table shows the minimum operator's skill for each machine operation.

Important: The factory manager must ensure that the operator has been properly trained on all the machine functions before starting work.

Skill 1: Machine Operator

This operator is trained to use the machine with the machine controls, to feed cases into the machine, make adjustments for different case sizes, to change the tape and to start, stop and restart production.

Skill 2: Mechanical Maintenance Technician

This operator is trained to use the machine as the MACHINE OPERATOR and in addition is able to:

- Work with the safety protection disconnected
- Check and adjust mechanical parts
- Carry out machine maintenance operations/repairs

He is not allowed to work on live electrical components

Skill 2a: Electrical Maintenance Technician

This operator is trained to use the machine as the MACHINE OPERATOR and in addition is able to:

- Work with the safety protection disconnected
 - Check and adjust mechanical parts
 - Carry out machine maintenance operations / repairs / adjustments / repair electrical components
- He is allowed to work on live electrical panels, connector blocks, control equipment, etc.

Skill 3: Specialist from the Manufacturer

Skilled operator sent by the manufacturer or its agent to perform complex repairs or modifications (on agreement with the customer).

 <b style="font-size: 1.2em; margin-left: 10px;">WARNING
<ul style="list-style-type: none"> • To reduce the risk associated with mechanical and electrical hazards: <ul style="list-style-type: none"> – Allow only properly trained and qualified personnel to operate and service this equipment.

Operator's Skill Levels Required to Perform the Main Operations on Machine

Operation	Machine Status	Required Operator Skill	Number of Operators
Machine installation and setup	Running with safety protections disabled	2 and 2a	2
Adjusting box size	Stopped by pressing the EMERGENCY STOP button	1	1
Tape replacement	Stopped by pressing the EMERGENCY STOP button	1	1
Blade replacement	Electric power disconnected	2	1
Drive belt replacement	Electric power disconnected	2	1
Ordinary maintenance	Electric power disconnected	2	1
Extraordinary mechanical maintenance	Running with safety protections disabled	3	1
Extraordinary electrical maintenance	Running with safety protections disabled	2a	1

3.12 Component Locations

Refer to **Figure 3-9** below to acquaint yourself with the various components and controls of the case sealer. Also refer to Manual 2 for taping head components.

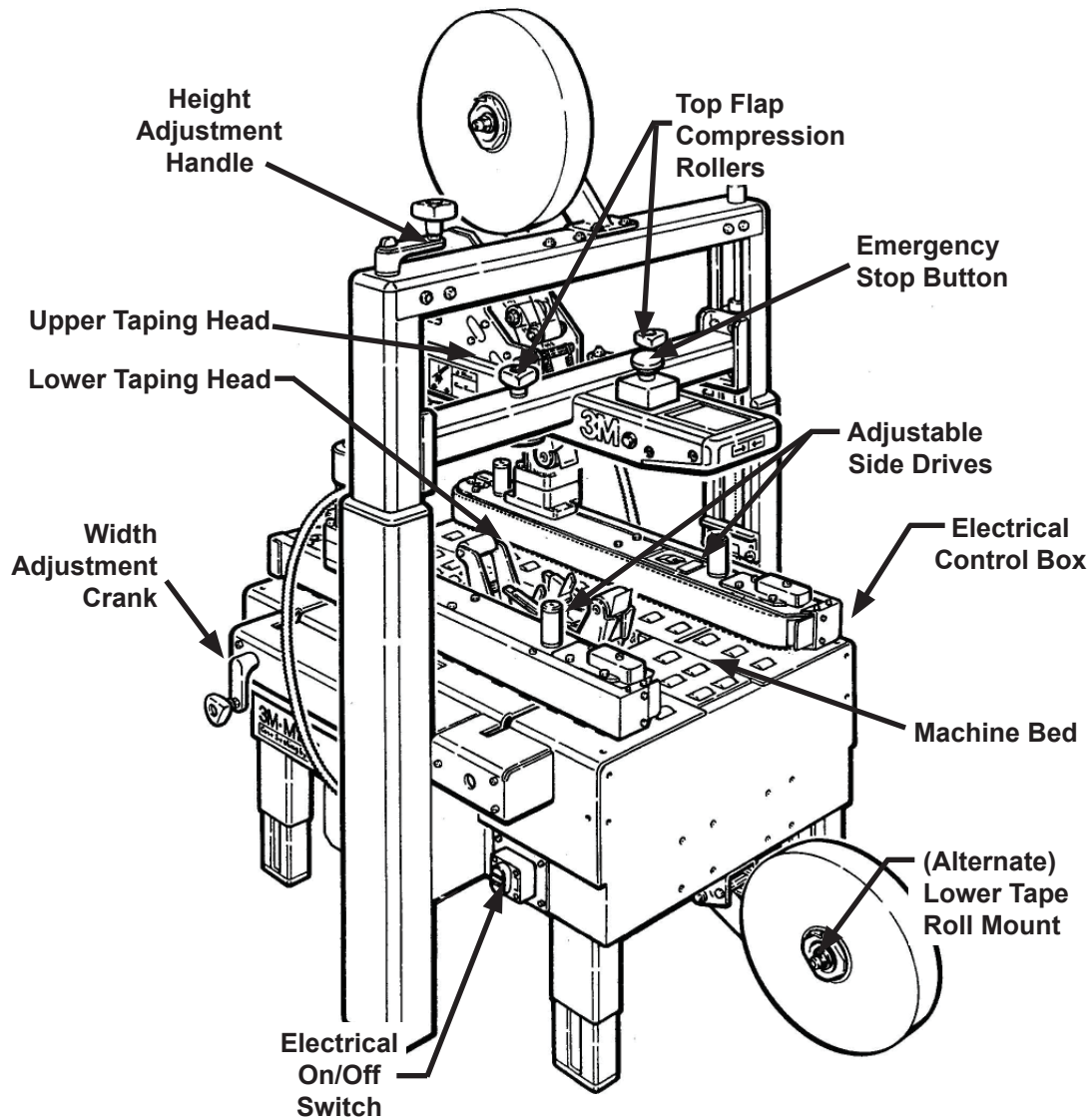

Figure 3-9—800a Case Sealer Components (Left Front View)

3.13 Table of Warnings and Replacements Labels (continued)

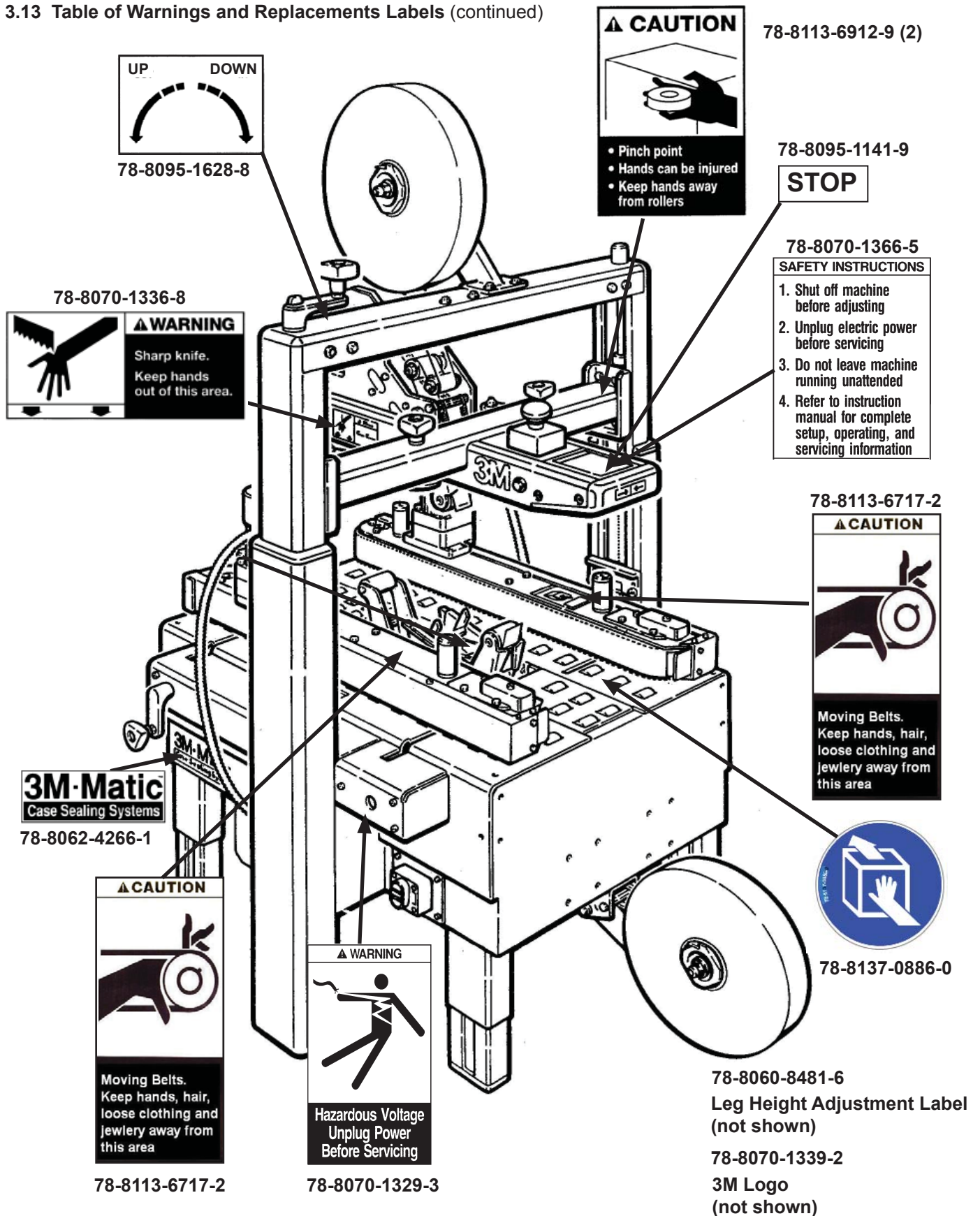

Figure 3-10 - Replacement Labels / 3M Part Numbers

4-SPECIFICATIONS

4.1 Power Requirements:

Electrical – 120 VAC, 60 Hz, 6 A

Pneumatic – 6.5 bar gauge pressure [95 PSIG], 2.5 SCFM

75 liter/minute @ 21° C., 1.01 bar maximum at maximum cycle rate.

A pressure regulator/filter is included.

The machine is equipped with two 1/6 HP gearmotors and comes with an 2.4 m [8 foot] standard neoprene covered power cord and a grounded plug. Contact your 3M Representative for power requirements not listed above. Contact your 3M Representative for power requirements not listed above.

4.2 Operating Rate:

Belt speed is 0.5 m/s [100 F.P.M.]

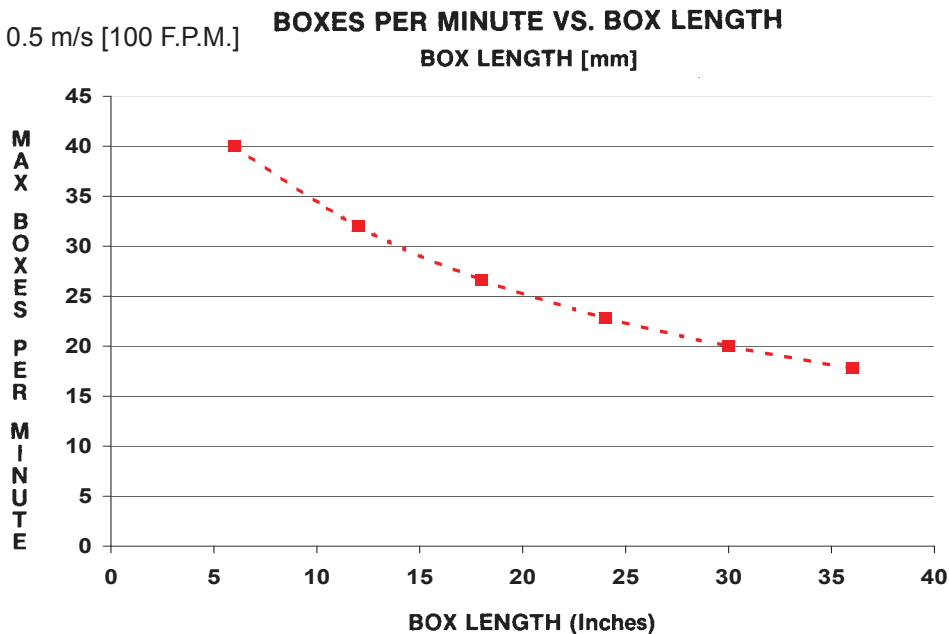

Actual production rate is dependent on operator's dexterity.

Boxes must be 18 inches [455mm] apart minimum.

Actual production rate is dependent on operator's dexterity. Boxes must be 18 inches (457mm) apart minimum.

4.3 Operating Conditions

Use in dry, relatively clean environments at 5° C to 50° C [40° F to 120° F] with clean, dry boxes.

Note: Machine should not be washed or subjected to conditions causing moisture condensation on components.

 **WARNING**

 **To reduce the risk associated with fire and explosion hazards:**

- Do not operate this equipment in potentially flammable or explosive environments.

4.4 Tape

Scotch® pressure-sensitive film box sealing tapes.

4.5 Tape Width

36mm [1 1/2 inch] minimum to 48mm [2 inch] maximum

4-SPECIFICATIONS (continued)

Specifications

4.6 Tape Roll Diameter

Up to 405mm [16 inch] maximum on a 76.2mm [3 inch] diameter core.

(Accommodates all system roll lengths of **Scotch®** film tapes.)

4.7 Tape Application Leg Length – Standard

70mm ± 6mm [2.75 inch ± .25 inch]

Tape Application Leg Length – Optional

50mm ± 6mm [2 inch ± .25 inch]

(See "Removing Taping Heads Procedure – Changing the Tape Leg Length")

4.8 Box Board

Style – regular slotted containers – RSC

125 to 275 P.S.I. bursting test, single wall or double wall B or C flute.

23-44 lbs. per inch of width Edge Crush Test (ECT)

4.9 Box Weight and Size Capacities

A. Box Weight, filled: 5 lbs.–85 lbs. [2.3 kg–38.6 kg]. Contents must support flaps.

B. Box Size:	Minimum	Maximum
Length –	150mm [6.0 inch]	Unlimited
Width –	115mm [4.5 inch]*	545mm [21.5 inch]
Height –	120mm [4.75 inch]** ***	620mm [24.5 inch] ***

* Minimum box height can be reduced to 110mm [4-1/4 inches] by removing machine compression rollers.

Minimum box height can be reduced to 90mm [3 1/2 inches] by removing machine compression rollers and also adjusting the taping heads to apply 48mm [2 inch] tape legs. (See "Special Set-Up Procedure".)

** Maximum box height can be increased to 725mm [28-1/2 inches] by relocating machine outer columns to upper position. (See "Special Set-Up Procedure".)

Note: Raising columns to upper position also increases minimum box height to 210mm (8 1/4").

Note: The case sealer can accommodate most boxes within the size range listed above. However, if the box length (in direction of seal) to box height ratio is 0.6 or less, test run several boxes to ensure proper machine performance.

DETERMINE THE BOX LIMITATIONS BY COMPLETING THIS FORMULA:

$$\frac{\text{BOX LENGTH IN DIRECTION OF SEAL}}{\text{BOX HEIGHT}} = \text{SHOULD BE GREATER THAN 0.6}$$

Any box ratio approaching this limitation should be test run to ensure performance.

4-SPECIFICATIONS (continued)

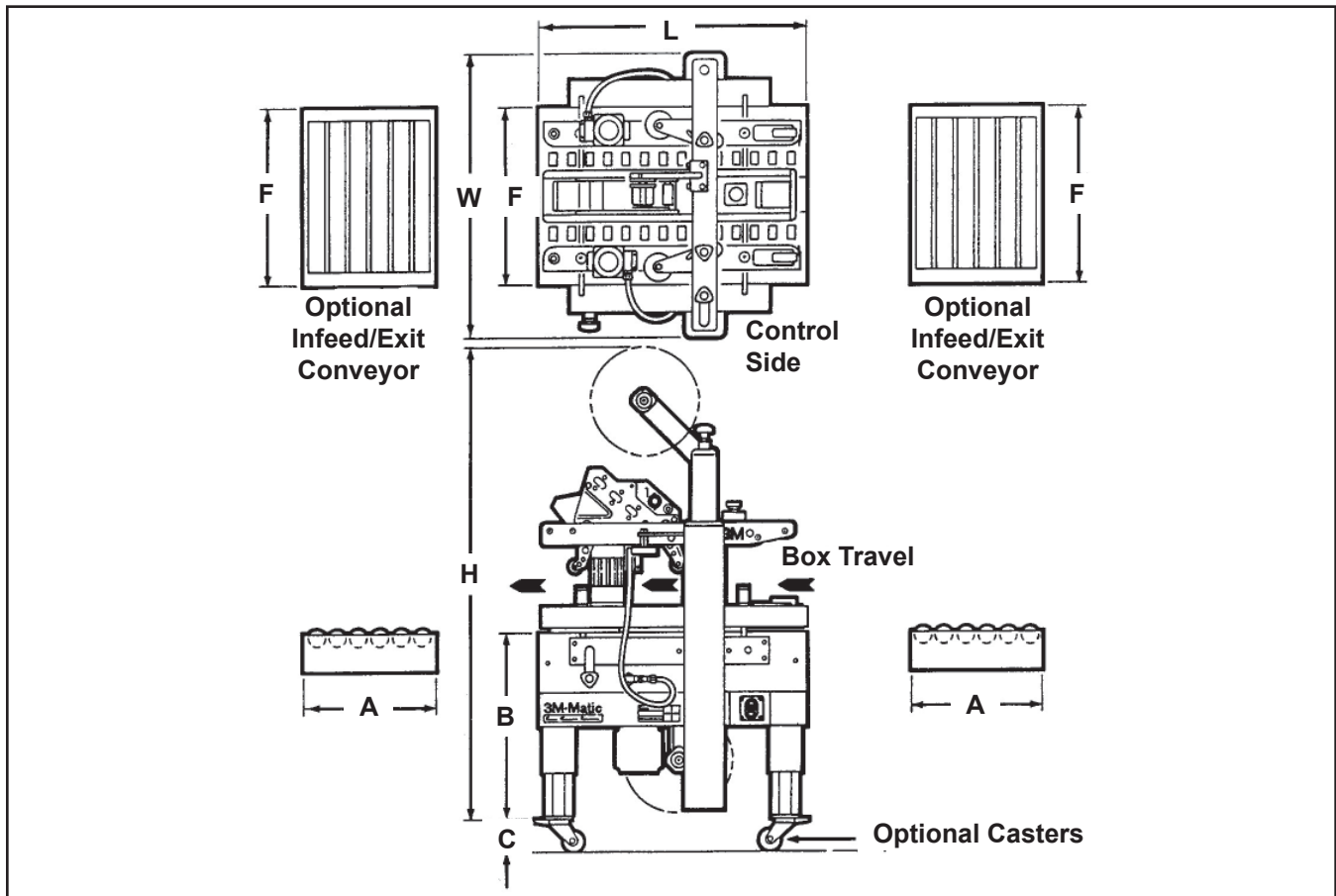

4.10 Machine Dimensions

	W	L	H	A*	B	C	F
Minimum							
mm	980	920	1395	460	610	105	620
[Inches]	[38-1/2]	[36-1/4]	[55]	[18]	[24]*	[4-3/16]	[24.5]
Maximum							
mm	--	--	2185	--	890	--	--
[Inches]	--	--	[86]*	--	[35]*	--	--

* With outer columns relocated to upper position, "H" maximum dimension increases 100mm [4 inches] and "B" minimum dimension decreases by 90mm [3-1/2 inches]. (See "Special Set-Up Procedure".)

Weight – approximate 176.9 kg [390 pounds] crated
 approximate 158.8 kg [350 pounds] uncrated

4.11 Machine Noise Level: Acoustic pressure measured at a distance of 1m. from machine with Scotch PVC adhesive tape in operation; 78dB Acoustic radiation pressure at 1.6m. height with Scotch PVC adhesive tape in operation; 73dB Measurement taken with appropriate instrument: (Type SPYRI-MICROPHON 11).

4.12 Set-Up Recommendations:

- Machine must be level.
- Customer supplied infeed and exit conveyors (if used) should provide straight and level box entry and exit.
- Exit conveyors (powered or gravity) must convey sealed boxes away from machine.

5.1 Shipment and Handling of Packed Machine

- The machine is fixed on the pallet with four (4) bolts and can be lifted by using a fork truck.
- The package is suitable to travel by land and by air.
- Optional sea freight package is available.

Packaging Overall Dimensions (Figure 5-1)

See Specifications.

During the shipment it is possible to stack a maximum of 2 machines (Figure 5-2).

5.2 Packaging for Overseas Shipment (Optional - Figure 5-3)

The machines shipped by sea freight are covered by an aluminum/polyester/polythene bag which contains dehydrating salts.

5.3 Handling and Transportation of Uncrated Machine

The uncrated machine should not be moved except for short distances and indoors ONLY. Without the supporting pallet, the machine is exposed to damage and may cause injuries. To move the machine use belts or ropes, paying attention to place them in the points indicated using care to not interfere with the lower taping head (Figure 5-4).

5.4 Storage of the Packed or Unpacked Machine

If the machine is not used for a long period, please take the following precautions:

- Store the machine in a dry and clean place.
- If the machine is unpacked it is necessary to protect it from dust.
- Do not stack anything over the machine.
- It is possible to stack a maximum of 2 machines (if they are in their original packing).

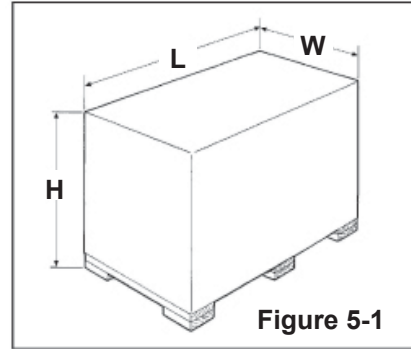

Figure 5-1

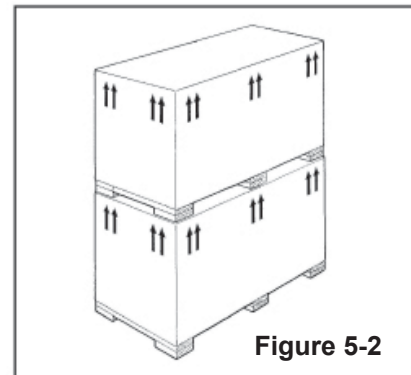

Figure 5-2

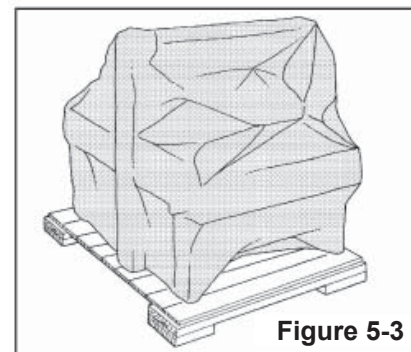

Figure 5-3

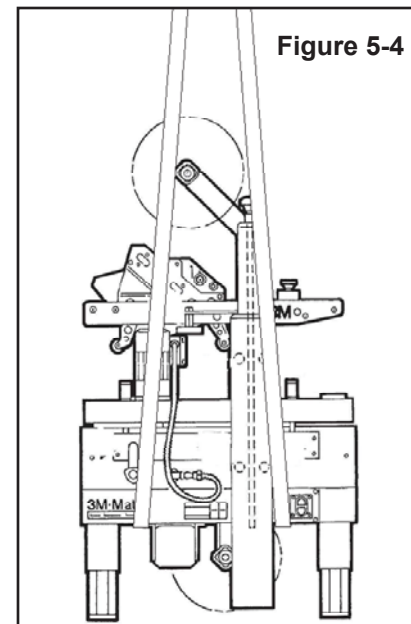
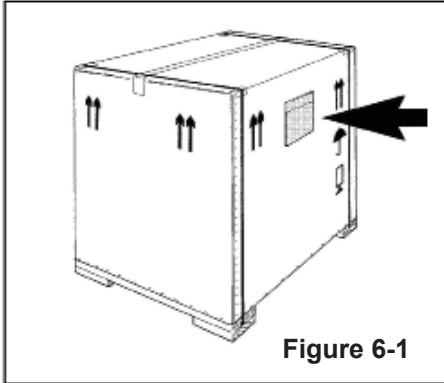

Figure 5-4

6-UNPACKING

6.1 Uncrating

The envelope attached to the shipping box contains the uncrating instructions of the machine (**Figure 6-1**).



Cut straps. Cut out staple positions along the bottom of the shipping box (or remove staples with an appropriate tool - **Figure 6-2**)

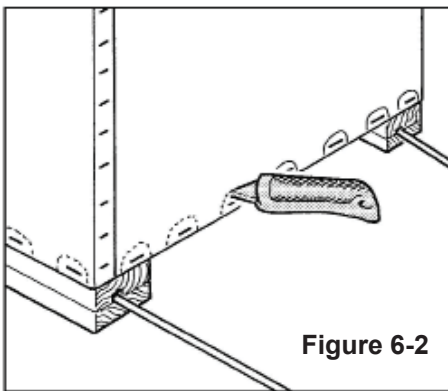

After cutting out or removing the staples, lift the shipping box in order to clear the machine (two persons required).

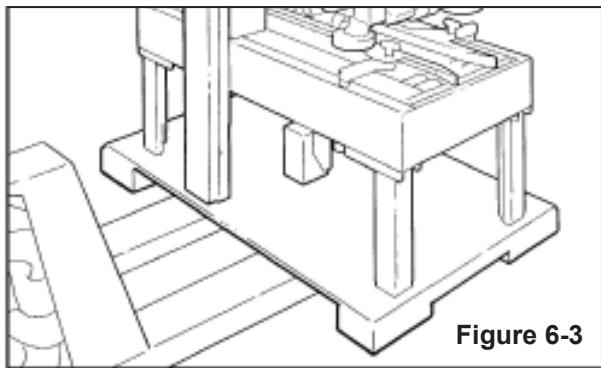

Transport the machine with a fork-lift truck to the operating position. Lift the pallet at the point indicated in **Figure 6-3** (weight of machine + pallet = See Specifications).

Removal of Pallet

Loosen and remove nuts and brackets using the open end spanner supplied in the tool box (**Figure 6-4**).

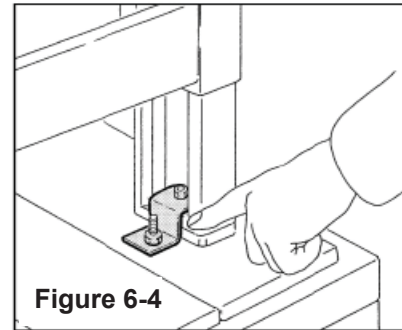

A cardboard box is located under the machine body. Retrieve the instruction manual for additional procedures of the set up. The box also contains parts removed for shipping, spare parts and tools (**Figure 6-5**).

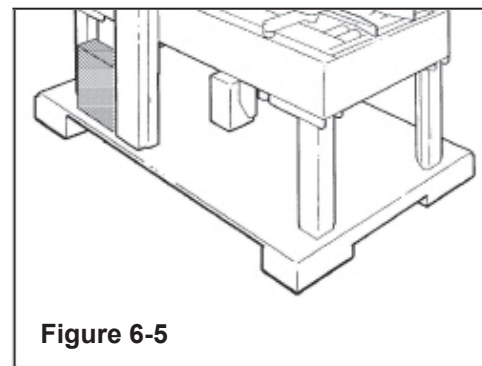

6.2 Disposal of Packaging Materials

The 800a package is composed of:

- Wooden pallet
- Cardboard shipping box
- Wooden supports
- Metal fixing brackets
- PU foam protection
- PP plastic straps
- Dehydrating salts in bag
- Special bag of laminated polyester/aluminium/ Polyethylene (sea freight package only)
- Polyethylene protective material

For the disposal of the above materials, please follow the environmental directives or the law in your country.

7-INSTALLATION

7.1 Operating Conditions

The machine should operate in a dry and relatively clean environment (See Specifications).

7.2 Space Requirements for Machine Operation and Maintenance Work

Minimum distance from wall (**Figure 7-1**):

A = 1000mm.

B = 700mm.

Minimum height = 2700mm.

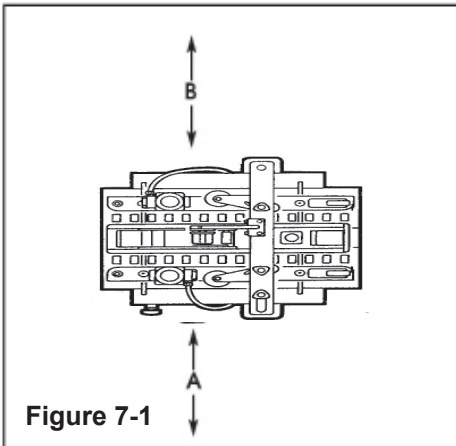
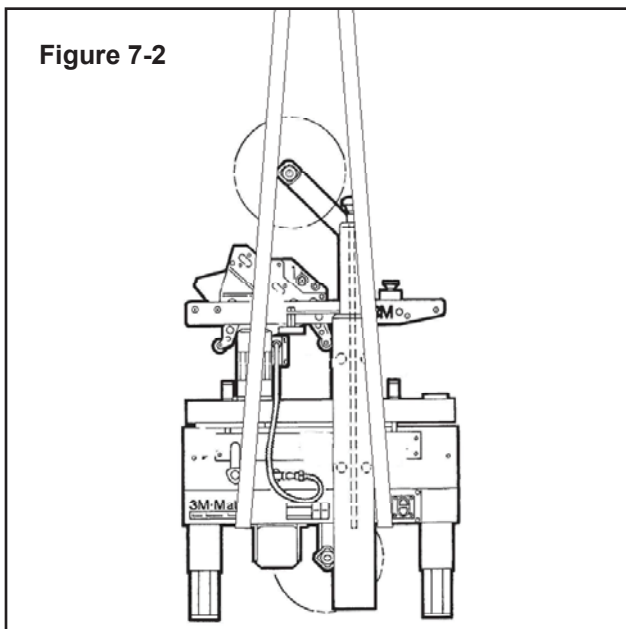

Figure 7-1

7.3 Tool Kit Supplied with the Machine

A tool kit containing some tools are supplied with the machine. These tools should be adequate to set-up the machine, however, other tools supplied by the customer will be required for machine maintenance.



800a-NA



WARNING

- **To reduce the risk associated with mechanical and electrical hazards:**
 - Allow only properly trained and qualified personnel to operate and service this equipment.



WARNING

- **To reduce the risk associated with muscle strain:**
 - Use the appropriate rigging and material handling equipment when lifting or repositioning this equipment.
 - Use proper body mechanics when removing or installing taping heads that are moderately heavy or may be considered awkward to lift.

7.4 Machine Set-Up / Bed Height

Adjust machine bed height. The case sealer is equipped with four (4) adjustable legs that are located at the corners of the machine frame. The legs can be adjusted to obtain different machine bed heights from 610mm [24 inches] minimum to 890mm [35 inches] maximum - See Specifications.

Refer to **Figure 7-3** and set the machine bed height as follows:

1. Raise and block up the machine frame to allow adequate leg adjustment.
2. Loosen, but do not remove, two (2) M8 x 16mm socket head screws in one leg (M6 hex wrench). Adjust the leg length for the desired machine bed height. Retighten the two (2) screws to secure the leg. Adjust all four (4) legs equally.

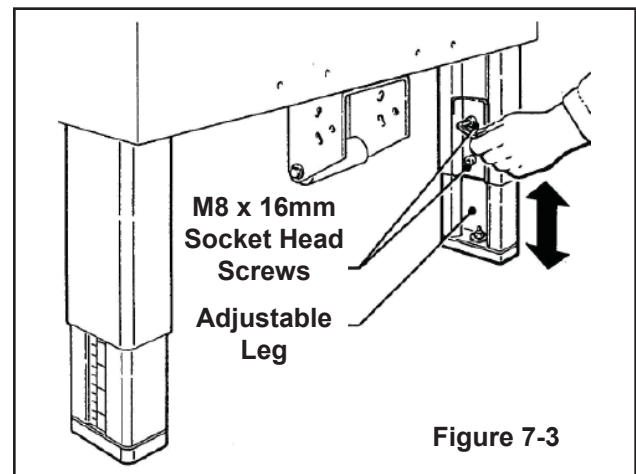

Figure 7-3

7.5 Removal of Plastic Ties

Cut the plastic which attaches the top head to the frame and remove the polystyrene blocks (Figure 7-4).

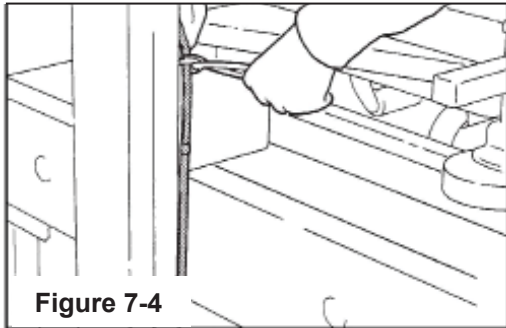

Figure 7-4

Cut the plastic ties holding the lower taping head in position (Figure 7-6).

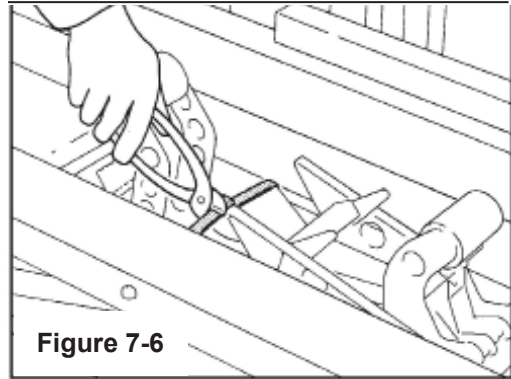

Figure 7-6

Cut the plastic strap which attaches the strip and the EMERGENCY STOP cable to the frame (Figure 7-5).

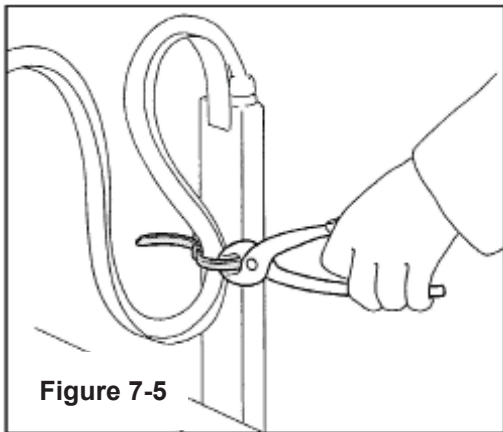

Figure 7-5

7.6 Assembly Completion

- 1 Crank - Install the crank handle on the top of the left column as shown (Figure 7-7A).
- 2 Tape Drum Bracket - Install the upper tape drum bracket on the top cross bar as shown (Figure 7-7B).
- 3 Stop Bracket - Raise upper head assembly (turn crank handle counterclockwise) and install the two stop brackets (provided in the parts bag). Use lower set of holes as shown in Figure 7-7D. The upper set of holes should only be used when both taping heads are adjusted to apply 50mm tape legs.

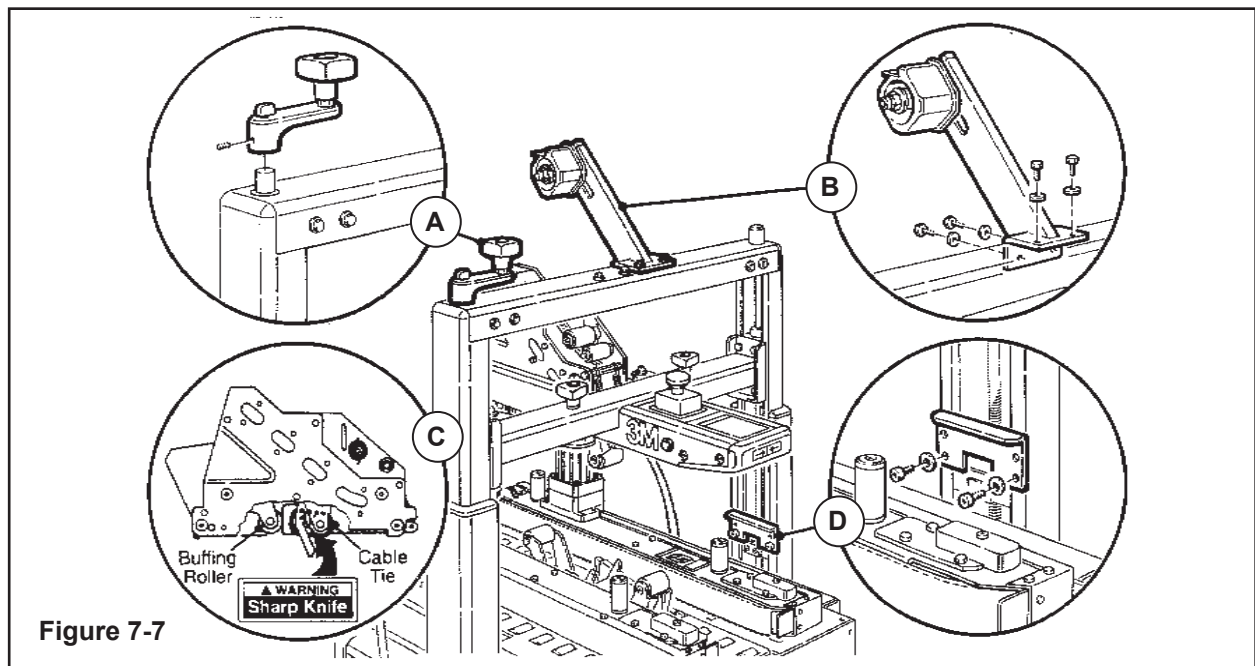

Figure 7-7

7.7 Completion of Taping Heads

See Manual 2 for Complete Instructions:

1. Place the Upper Taping Head in a convenient working position
2. Use **Figure 7-8** and tape threading label. Position the tape supply roll so the adhesive side of tape is facing the front of the taping head as it is pulled from the supply roll.
3. Attach the threading needle to the end of the roll. Guide the threading needle around the wrap roller (**Position 1**) then back around the one-way tension roller (**Position 2**).
4. Continue pulling the threading needle down and guide it between the two (2) rollers on the apply arm (**Position 3**).
5. Pull the threading needle down until the tape travels between the apply plate and the ears of the apply arm (**Position 4**) until it extends past the applying roller. When properly threaded the adhesive side of the tape should be facing the knurled rollers at position 2 and also position 3.
6. Cut away any excess tape and repeat steps for Lower Taping Head.

Important – Do not cut against the apply roller - roller damage could occur.

7.8 Outboard Tape Roll Holder

If you intend to use the outboard tape roll holder, proceed as follows:

- 1 - Remove the lower taping head from the machine.
- 2 - Remove the tape drum bracket assembly, stud spacer, and fasteners from the lower taping head.
- 3 - Install alternative wrap roller and bracket on the head in place of tape bracket. Replace lower head into machine.
- 4 - Install and secure tape drum bracket assembly on the entry end of the lower frame (as shown in **Figure 7-9**).

7.9 Preliminary Electric Inspection

Before connecting the machine to the mains please carry out the following operations:

- 7.9.1 Make sure that the socket is provided with an earth protection circuit and that both the mains voltage and the frequency match the specifications on the name plate.
- 7.9.2 Check that the connection of the machine to the mains meets the safety regulations in your country.
- 7.9.3 The machine is fitted with a main switch and a circuit breaker. The user should check that the electrical settings of the machine are compatible with all the components of the mains system.

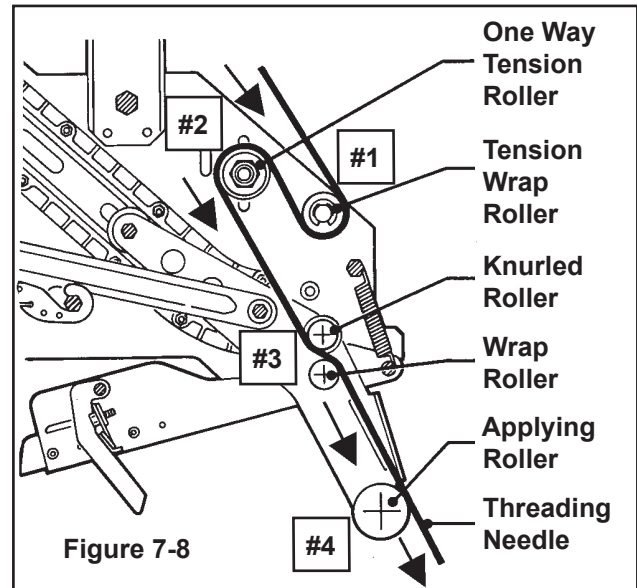

Figure 7-8

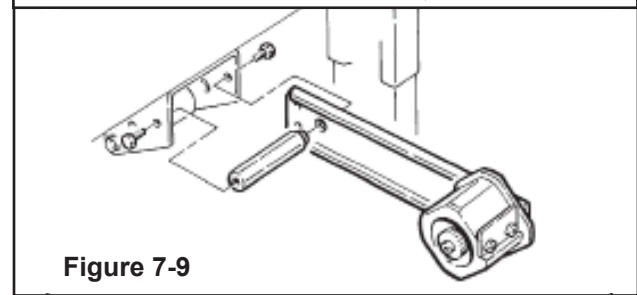

Figure 7-9

7.10 Machine Connection to the Mains

For technical specifications: **See Section 4 - Specifications**

- Push the LATCHING EMERGENCY STOP BUTTON.
- The main switch is normally OFF (O).

Connect the power cord supplied with the machine to a wall socket using a plug which complies with the safety regulations of your country.

7.11 Inspection of Phases (For Three-Main Phases Only)

N/A for this machine.

8-THEORY OF OPERATION

8.1 Description of the Working Cycle

After having closed the top flaps of the carton, the operator pushes it under the top infeed end in order to avoid the opening of the top flaps. Further pushing causes the two bottom side belts to drive the box through the taping heads which automatically seal the top and bottom seams. The carton is then expelled on the exit conveyor.

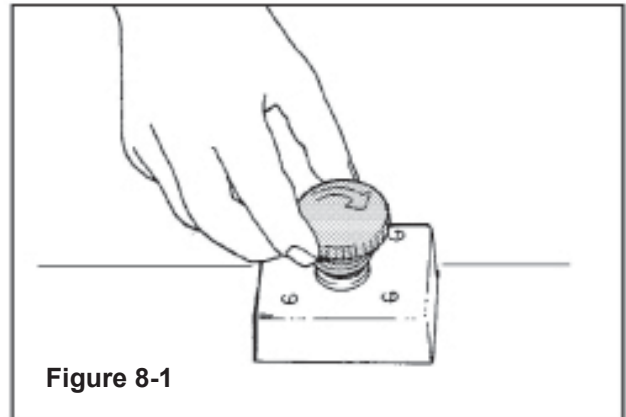

Figure 8-1

8.2 Definition of Running Mode

The case sealer 800a has only one (automatic) operating mode with:

- The EMERGENCY STOP BUTTON unlocked (Figure 8-1)
- The main switch start switch "ON" (I) (Figure 8-2)

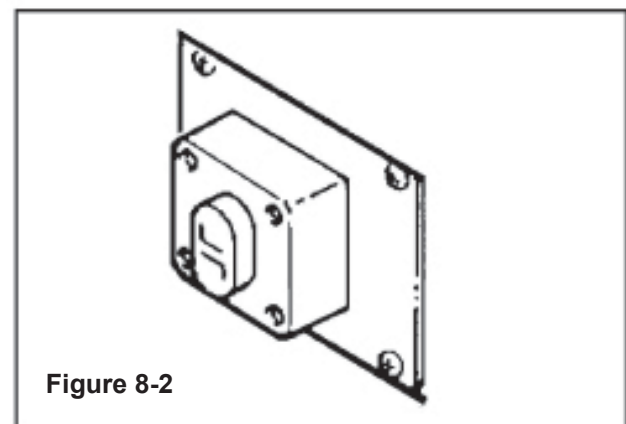

Figure 8-2

8.3.1 Normal Stop Procedure

When the main switch is OFF (O), the machine stops immediately at any point of the working cycle. The same thing happens in case of electrical failure or when the machine is disconnected from the mains.

8.3.2 Emergency Stop

The LATCHING EMERGENCY STOP BUTTON is located on the top center of the machine (Figure 8-1).

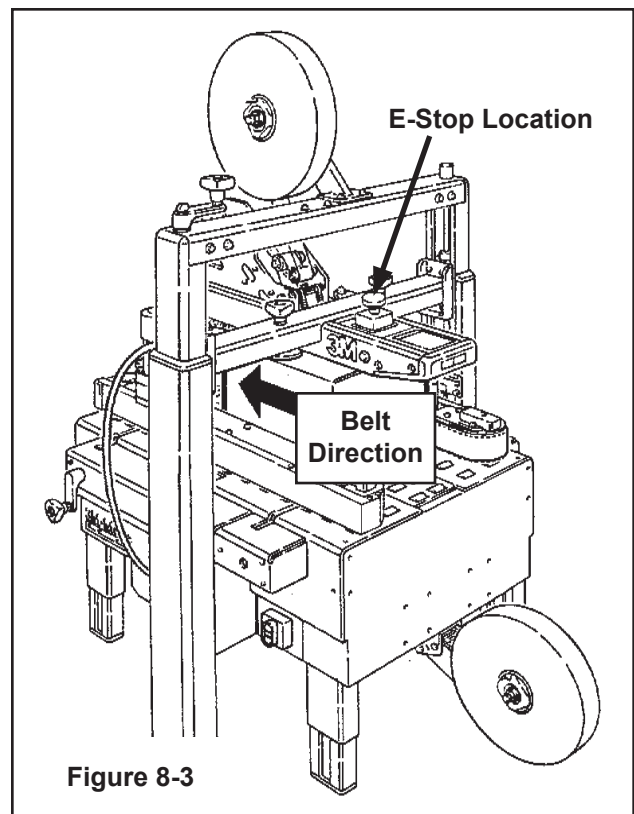
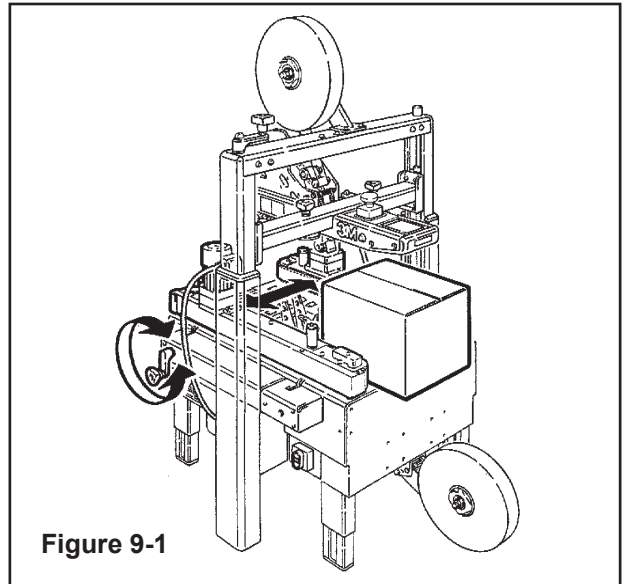
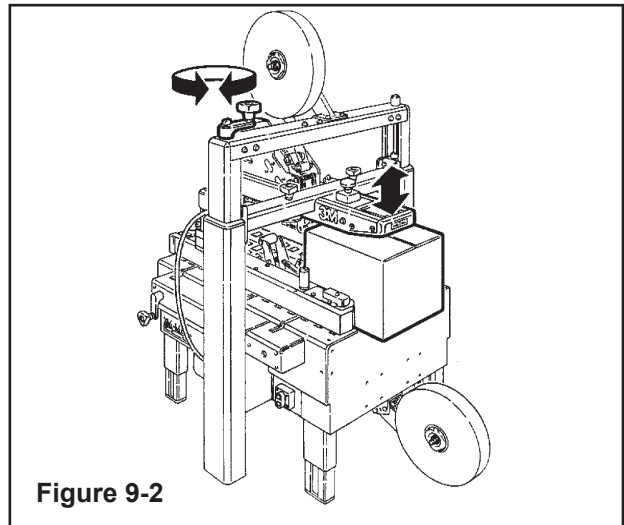

Figure 8-3

9.1 Box Width Adjusting Knobs



9.2 Box Height Adjusting Crank



9.3 Start/Stop Button

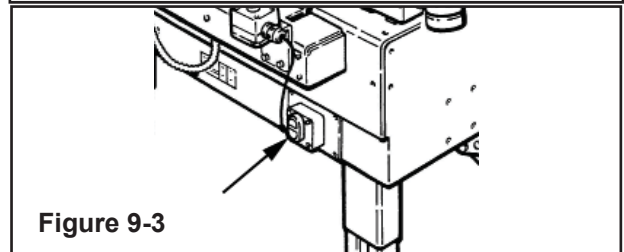

9.4 Latching Emergency Stop Button

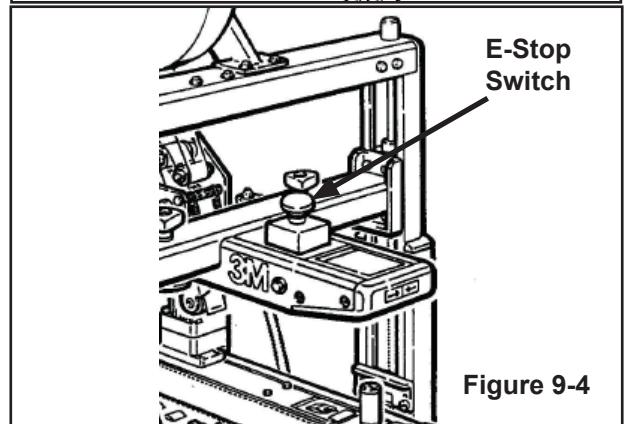

10-SAFETY DEVICES OF THE MACHINE

10.1 Blade Guards

Both the top and bottom taping units have a blade guard. (See Manual 2: AccuGlide™ 3 Taping Heads - 2 Inch).



WARNING

- **To reduce the risk associated with sharp blade hazards:**
 - Keep hands and fingers away from tape cutoff blades under orange blade guards. The blades are extremely sharp.

10.2 Emergency Stop Button

The box drive belts are turned on and off with the electrical switch on the side of the machine frame.

The machine electrical supply can be turned off by pressing the latching emergency stop switch. To restart machine, rotate the emergency stop switch clockwise to release the switch latch. Restart machine by Pushing the On/Off switch to the Off (O) position and then to the On (I) position (**Figure 10-1**).



WARNING

- **To reduce the risk associated with hazardous voltage:**
 - Position electrical cord away from foot and vehicle traffic.

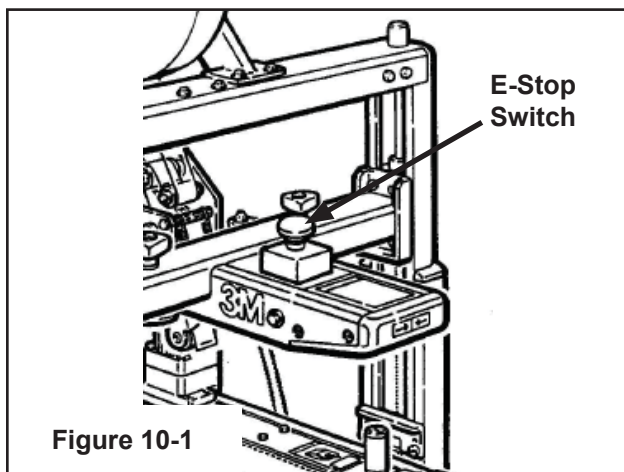

Figure 10-1

10.3 Electric System / Circuit Breaker

The electric system is protected by a ground wire whose continuity has been tested during the final inspection. The system is also subject to insulation and dielectric strength tests.

Circuit Breaker

The case sealer is equipped with a circuit breaker which trips if the motors are overloaded. Located inside the electrical enclosure on the side of the machine frame just below the machine bed, the circuit breaker has been pre-set and requires no further maintenance.



WARNING

- **To reduce the risk associated with mechanical and electrical hazards:**
 - Allow only properly trained and qualified personnel to operate and service this equipment.

If circuit is overloaded and circuit breaker trips, unplug machine from electrical power:

1. Determine cause of overload and correct.
2. Plug in machine.
3. Press machine "On" button to resume case sealing.

Important: The use of an extension cord is not recommended. However, if one is needed for temporary use, it must:

- Have a wire size of 1.5mm diameter [AWG 16]
- Have a maximum length of 30.5m [100 ft]
- Be properly grounded.

11 - SET UP AND ADJUSTMENTS

11.1 Box Width Adjustment

Place a product filled box on infeed end of machine bed with top flaps folded as shown and manually move box forward to contact lower taping head applying roller.

Turn drive belt adjustment crank to position both side drive belts against sides of box (**Figure 11-1**).

11.2 Box Height Adjustment

Turn height adjustment crank to position upper taping head onto box. Turn clockwise to lower head, counterclockwise to raise head. Upper taping head must contact and hold top box flaps closed (**Figure 11-2**).

11.3 Adjustment of Top Flap Compression Rollers

The top flap compression rollers have an adjustable slide mounting to provide side compression through the full range of box widths.

Manually move box forward so front of box is aligned with top flap compression rollers.

Adjust the compression rollers against top edge of box and tighten knobs to secure rollers in operating position (**Figure 11-3**).

11.4 Changing the Tape Leg Length

Taping heads are preset to apply 70mm [2.75 inches] long tape legs. To change tape leg length to 50mm [2.0 inches], refer to Instructions below and also to Manual 2, "Removing Taping Heads Procedure - Changing the Tape Leg Length".

11.5 Run Boxes to Check Adjustment

Push electrical switch "On" (I) to start drive belts.

Move box forward under upper taping head until it is taken away by drive belts. If box is hard to move under head or is crushed, raise head slightly.

If the box movement is jerky or stops under the upper head, move the side drive belts in slightly to add more pressure between the box and drive belts.

Important – If drive belts are allowed to slip on box, excessive belt wear will occur.

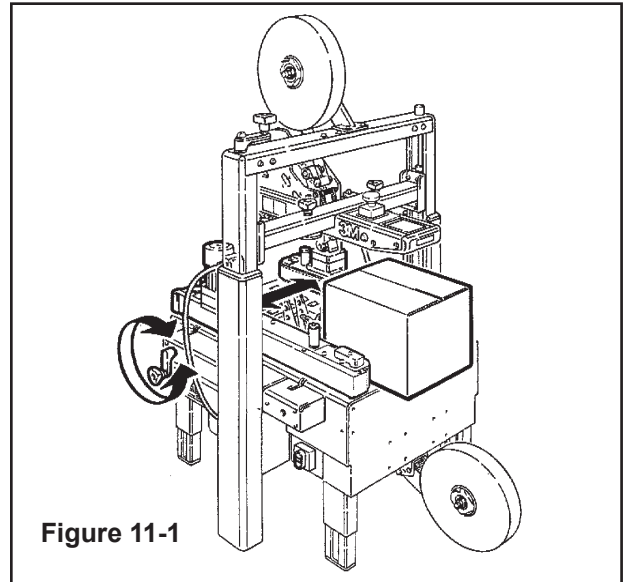

Figure 11-1

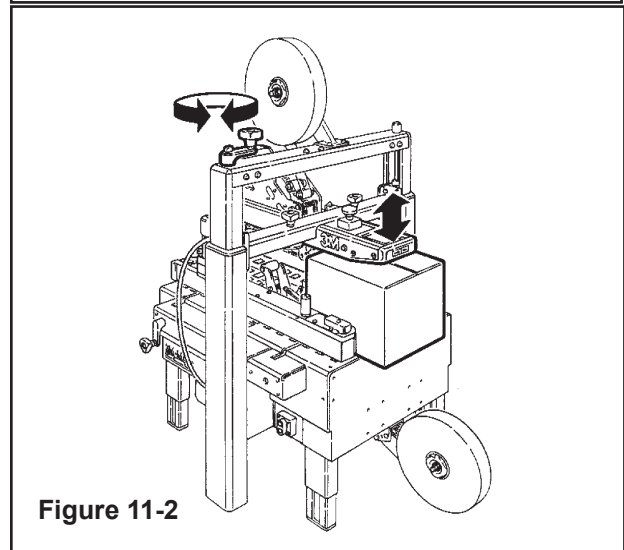

Figure 11-2

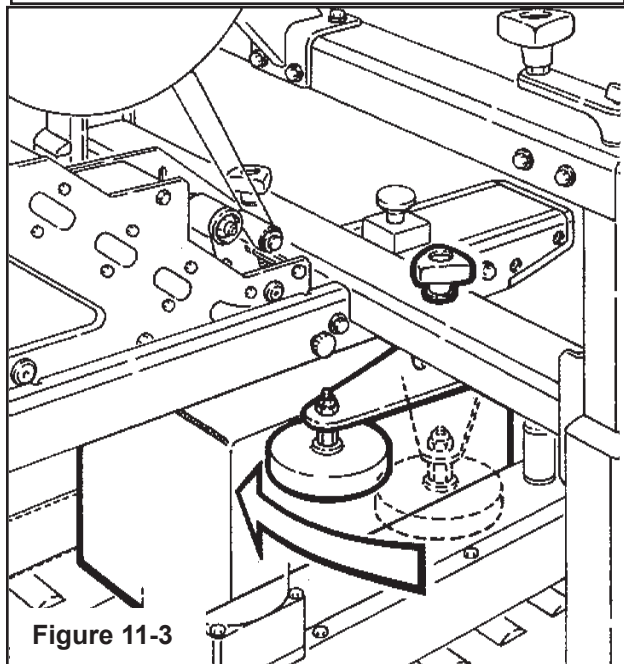

Figure 11-3

12-OPERATION

12.1 Operator's Correct Working Position and Operational Flow (Figure 12-1).

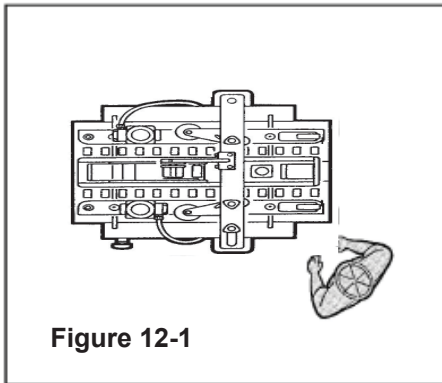

Figure 12-1

Once the box has been filled, close its top flaps and push it between the top and bottom drive belts. Always keep hands in position as shown in Figure 12-2.

The box will be automatically sealed with adhesive tape on the top and bottom box seams. Then the box will be expelled on the exit conveyor.

Figure 12-2

Hand
Position

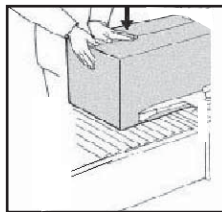

12.2 Starting the Machine

Important: Before starting the machine, verify that no tools or other objects are on the conveyor bed.

Push the main switch ON (I) after the EMERGENCY BUTTON is released (Figure 12-3).

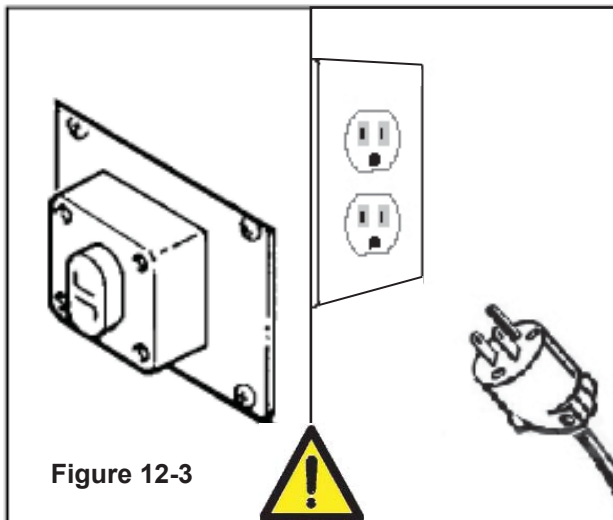

Figure 12-3

12.3 Starting Production

After having adjusted the machine according to the box dimensions (height-width), let the machine run without cartons and check its safety devices. Then start the working cycle.

12.4 Tape Replacement and Threading

Skill 1 - Operator

See Manual 2: AccuGlide™ 3 High Speed 2 Inch Taping Heads.

Press the
LATCHING EMERGENCY STOP BUTTON.



WARNING

- To reduce the risk associated with sharp blade hazards:
 - Keep hands and fingers away from tape cutoff blades under orange blade guards. The blades are extremely sharp.

12.5 Box Size Adjustment

Repeat all the operations shown in Section 11 - Set-Up and Adjustments.

12.6 Cleaning

Before carrying out any cleaning or maintenance operation stop the machine by Pushing the OFF (O) switch on the main and disconnect the electric power (Figure 12-3).

12.7 Table of Operation Adjustments - Operator Qualifications

1	Tape loading and threading	1
2	Tape web alignment	1
3	Adjustment of one way tension roller	1
4	Adjustment to box size (H and W)	1
5	Top flap compression rollers	1
6	Adjustment of tape applying spring	1
7	Conveyor bed height adjustment	1
8	Special Adjustment-Changing tape leg length	2
9	Special Adjustment-Column re-positioning	2

12.8 Safety Devices Inspection

- 1 Taping units blade guard
- 2 Latching emergency stop button
- 3 STOP (OFF) (O) main switch

12-OPERATION (continued)

Troubleshooting Guide

Problem	Cause	Correction
Drive belts do not convey boxes	Narrow boxes	Check machine specifications. Boxes are narrower than recommended, causing slippage and premature belt wear.
	Worn drive belts	Replace drive belts
	Top taping head does not apply enough pressure	Adjust the box height adjustment with the crank
	Top flap compression rollers in too tight	Readjust compression rollers
	Taping head applying spring holder missing	Replace spring holder
Drive belts do not turn	Taping head applying spring set too high	Reduce spring pressure
	Worn or missing friction rings	Replace friction rings
	Drive belt tension too low	Adjust belt tension
	Electrical disconnect	Check power and electrical plug
Drive belt break	Motor not turning	Evaluate problem and correct
	Worn belt	Replace belt
Squeaking noise as boxes pass through machine	Excessive belt tension	
	Dry column bearings	Tension to 3.5 kg [7 lbs] per adjustment section
	Defective column bearings	Lubricate column bearings Replace column bearings
Tape not centered on box seam	Tape drum not centered	Reposition tape drum
	Box flaps not of equal length	Check box specifications

13-MAINTENANCE AND REPAIRS

13.1 Safety Measures (see section 3)

Carrying out maintenance and repairs may imply the necessity to work in dangerous situations.

13.2 Tools and Spare Parts Supplied with the Machine

See Spare Parts Order Section.

13.3 Recommended Frequency of Inspection and Maintenance Operations

Operation	Frequency	Qualification	Sections
Inspection safety features	daily	1	13.4
Cleaning of machine	weekly	1	13.5
Cleaning of cutter blade	weekly	2	13.6
Oiling of felt pad	weekly	2	13.7
Lubrication	monthly	2	13.7-13.8
Blade replacement	when worn	2	See Manual 2
Drive belt replacement	when worn	2	13.10

13.4 Inspections to be Performed Before and After Every Maintenance Operation

Before every maintenance operation, Push the main switch OFF (O) and disconnect. During the maintenance operation, only properly trained and qualified personnel must work on the machine. At the end of every maintenance operation check the safety devices.

13.5 Check Efficiency of Safety Features

1. Blade guard assembly upper taping head
2. Blade guard assembly lower taping head
3. Latching Emergency stop button with mechanical lock (interrupt supply of electrical power)
4. Push the main switch STOP/OFF (O)
5. Safety guards top drive belts

13.6 Cleaning of Machine

Qualification 1

A weekly cleaning with dry rags or diluted detergents is necessary. Cardboard boxes produce a significant quantity of dust and paper chips when processed or handled in case sealing equipment. If this dust is allowed to build up on machine components, it can cause component wear and over-heating of drive motors. The dust build up is best removed from the machine with a vacuum cleaner. Depending on the number of cartons processed, this cleaning should be done weekly. Excessive build-up that cannot be removed by vacuuming should be removed with a damp cloth.

13.7 Cleaning of Cutter Blade

Qualification 2

Should tape adhesive build-up occur, carefully wipe clean with oily cloth or brush (**Figure 13-1**). Oil prevents the build-up of tape adhesive.

(See Manual 2)



WARNING

- **To reduce the risk associated with mechanical and electrical hazards:**
 - Read, understand, and follow all safety and operating instructions before operating or servicing the case sealer.
 - Allow only properly trained and qualified personnel to operate and service this equipment.
- **To reduce the risk associated with pinches, entanglement and hazardous voltage:**
 - Turn electrical supply off and disconnect before performing any adjustments, maintenance or servicing the machine or taping heads.



WARNING

- **To reduce the risk associated with pinch, entanglement and hazardous voltage:**
 - Turn electrical supply off and disconnect before performing any adjustments, maintenance or servicing the machine or taping heads

13.8 Drive Belt Replacement

Note – 3M recommends the replacement of drive belts in pairs, especially if belts are unevenly worn.

Replacement - See Steps 1 thru 8

Tension Adjustment - See Steps 3, 7 and 9.

1. Crank the upper taping head to its fully raised position.
2. Remove and retain the three (3) screws (A), three (3) washers (B) and side cover (C). **See Figure 13-4.**
3. Remove and retain the screw (D), washer (E) and belt tensioner cover (F).
4. Turn belt adjustment screws (G) counterclockwise on both the upper and lower tension assemblies until belt is loose. **See Figure 13-5.**
5. Locate the belt lacing (joint) by turning the belt manually. Remove the pin with pliers. Remove and discard old belt.



WARNING

- **To reduce the risk associated with mechanical and electrical hazards:**
 - Allow only properly trained and qualified personnel to operate and/or service this equipment

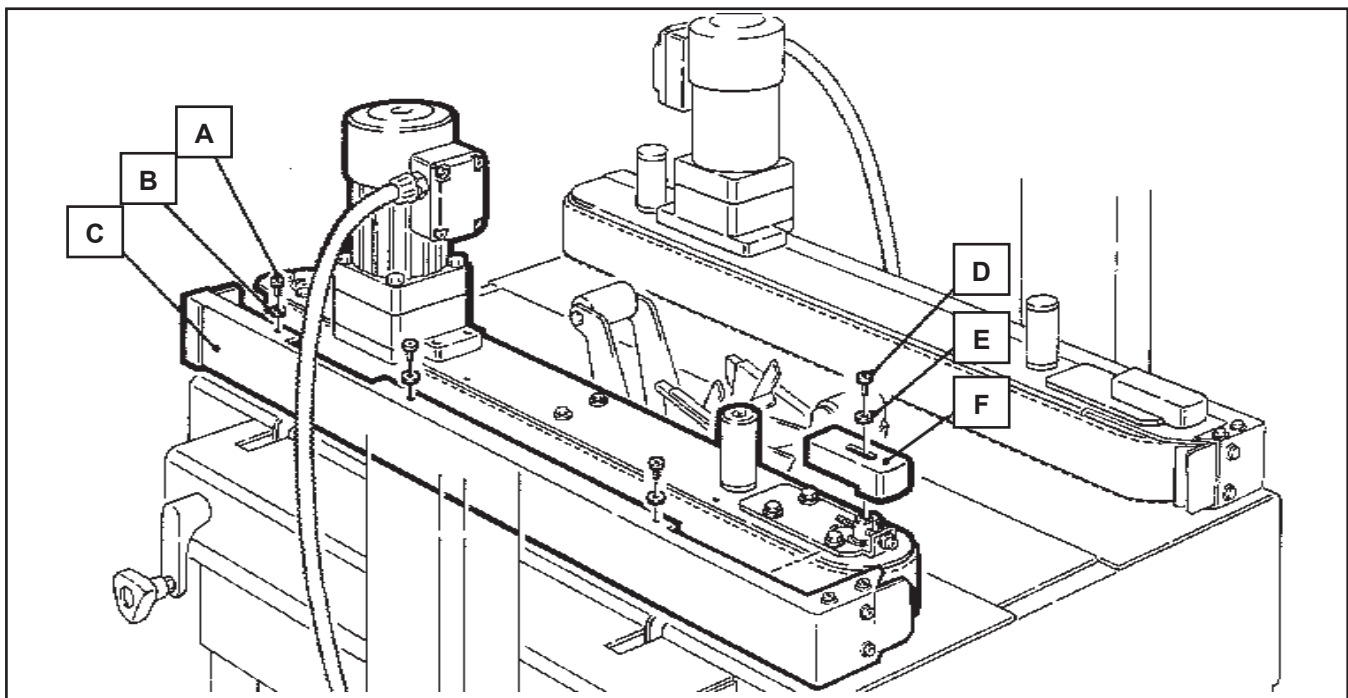

Figure 13-4 – Box Drive Belt (Left Side View – Infeed End)

 **WARNING**

- **To reduce the risk associated with pinch, entanglement and hazardous voltage:**
 - Turn electrical supply off and disconnect before performing any adjustments, maintenance or servicing the machine or taping heads

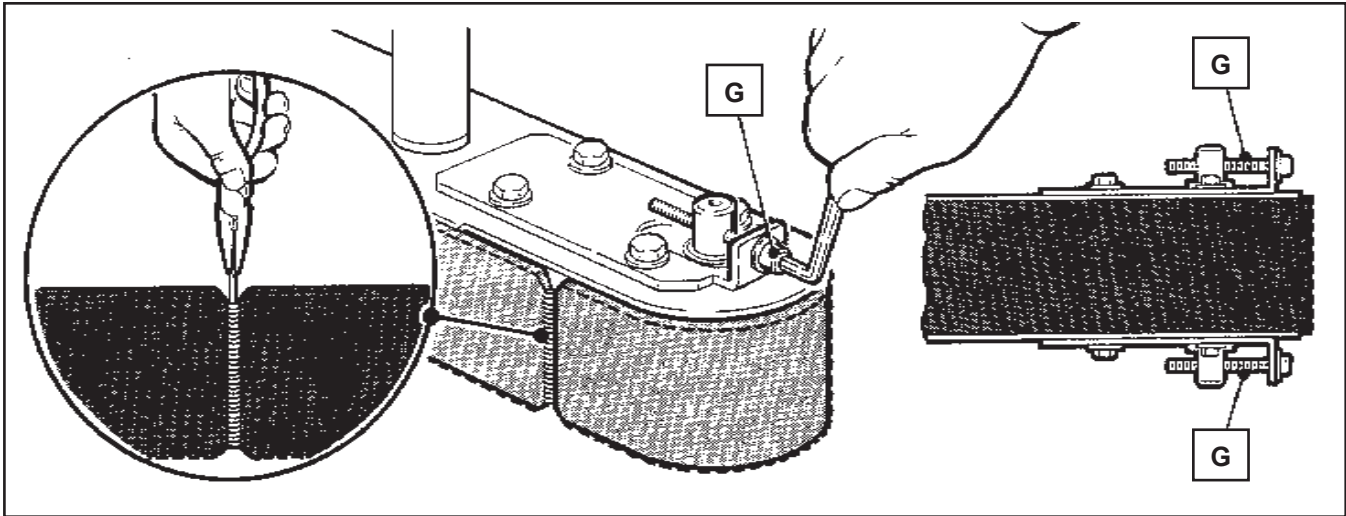

Figure 13-5 – Box Drive Assembly, Infeed End

6. Install the new belt around drive rollers and insert new pin. Pin must not extend beyond edge of belt.
7. To set drive belt tension, turn adjustment screws (G) equally on both the upper and lower tension assemblies. Turn the screws clockwise to increase tension or counterclockwise to decrease tension. **See Figure 13-5.**
Use a force gauge to pull the belt outward 25mm [1 inch] at mid span, as shown with a moderate pulling force of 3.5 kg [7 lbs].
8. Reverse procedures in Steps 1-3 (**Figure 13-4**) to reassemble the drive belt assembly.

Important – Before installing new drive belt, check the belt inside surface for drive direction arrows and install belt accordingly. If no arrows are shown, the belt may be installed either way.

13.9 Drive Pulley Rings

Before installing a new belt, check the orange plastic drive pulley rings for wear. If torn, broken, or worn smooth, replace the rings (**Figure 13-6**).

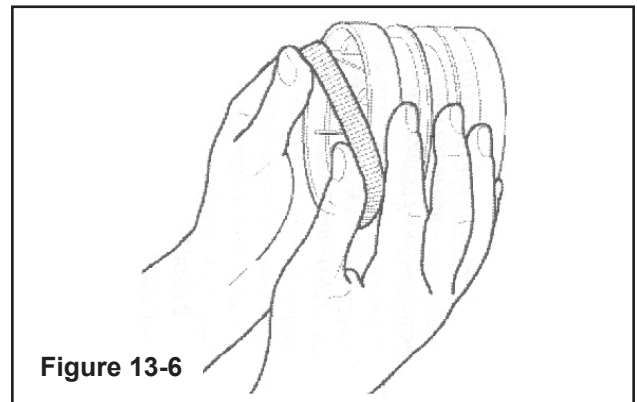
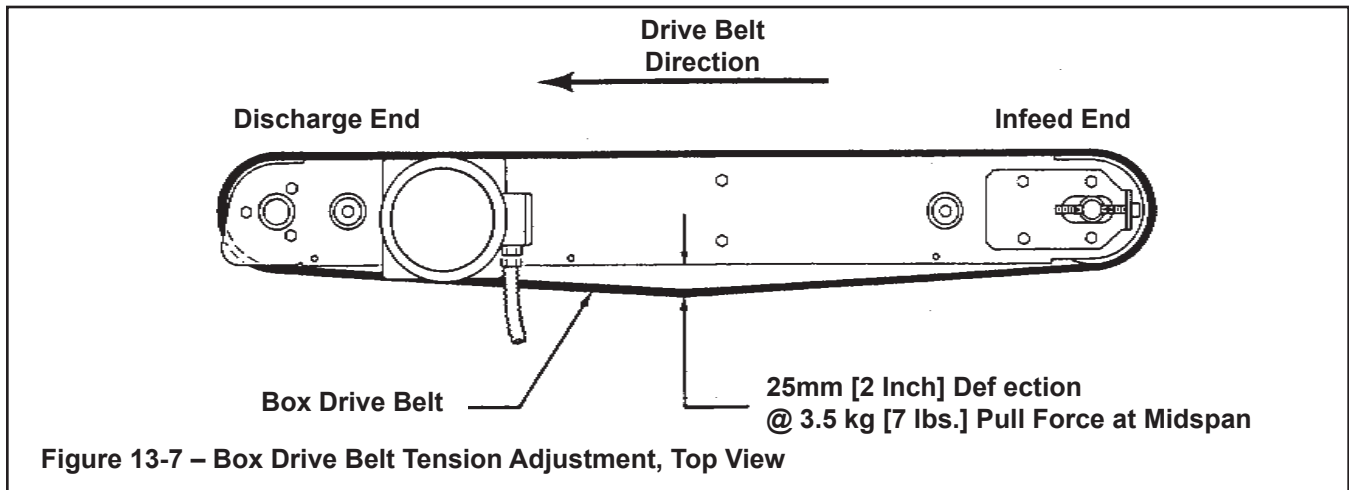

Figure 13-6



WARNING

- **To reduce the risk associated with pinch, entanglement and hazardous voltage:**
 - Turn electrical supply off and disconnect before performing any adjustments, maintenance or servicing the machine or taping heads

13.10 Drive Belt Tension

Tension adjustment of the drive belts may be required during normal operation. Belt tension must be adequate to positively move the box through the machine and they should run fully on the surface of the pulleys at each end of the frame. The idler pulleys on the infeed end are adjusted in or out to provide proper belt tension. Each belt is adjusted separately.

Belt tension is obtained by tightening the adjustment screw so that a moderate pulling force of 3.5 kg [7 lbs] applied at the mid span, as shown in **Figure 13-7**, will deflect the belt 25mm [1 inch]. This will assure positive contact between the belt and the drive pulley on the discharge end of the taping head.

To adjust belts, see "Maintenance – Drive Belts", steps 3 and 7.

13.11 Special Set-Up Procedure



WARNING

- **To reduce the risk associated with mechanical and electrical hazards:**
 - Turn electrical and air supply off and disconnect before performing any adjustments, maintenance, or servicing the machine or taping heads

The following changes to the case sealer will allow taping boxes 90mm [3-1/2 inches] minimum height.

13.11.1 Case Sealer Frame (Refer to **Figure 13-8A**)

1. Raise the upper head assembly (by turning crank handle counterclockwise). Remove and retain the two screws and washers from the normal position holes "A-A".
2. Remount and secure the stop bracket in the lower position "A" using the top holes and original fasteners. Relocate both the right and left stop brackets.

13.11.2 Taping Heads
(Refer to Figure 13-8B and Figure 13-8C)

Taping Head Adjustments



WARNING



To reduce the risk associated with sharp blade hazards:

- Keep hands and fingers away from tape cutoff blades under orange blade guards. The blades are extremely sharp

TAPE WEB ALIGNMENT – Manual 2

TAPE DRUM FRICTION BRAKE – Manual 2

APPLYING MECHANISM SPRING – Manual 2

ONE-WAY TENSION ROLLER – Manual 2

TAPE LEG LENGTH

Leading Tape Leg Length Adjustment – Manual 2

Changing Tape Leg Length from 70 to 48mm [2-3/4 to 2 inches] – Manual 2

Note – Changing tape leg to 48mm [2 inches] requires machine adjustment also. See Manual 2 "Special Set-Up Procedure – Changing Tape Leg Length".

1. Loosen, but do not remove, the two (2) retaining screws that secure the upper taping head shown - **Figure 13-8B**.

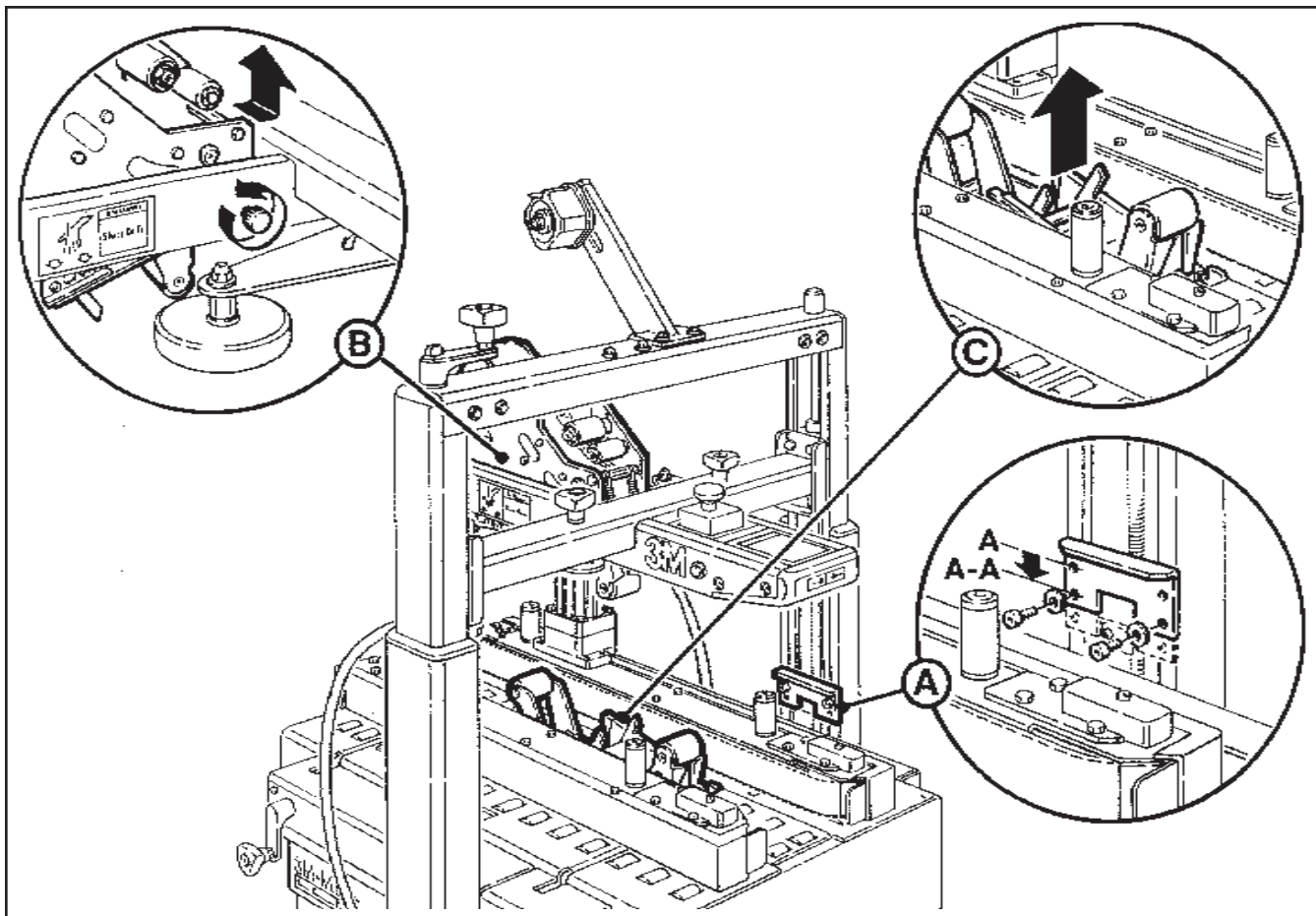

Figure 13-8 – Removing Taping Heads From Case Sealer

13.11.2 Special Set-Up Procedure (continued)



WARNING

- **To reduce the risk associated with muscle strain:**
 - Use the appropriate rigging and material handling equipment when lifting or repositioning this equipment.
 - Use proper body mechanics when removing or installing taping heads that are moderately heavy or may be considered awkward to lift.

2. Slide the head forward and lift straight up to remove it from the case sealer.
3. Lift the lower taping head, shown in **Figure 13-8C**, straight up to remove it from the case sealer bed.
4. Refer to Manual 2 (Taping Head), See "Adjustments – Changing Tape Leg Length" for taping head set-up.

13.11.3 Drive Belt Assembly Height

The drive belt assemblies can be raised 48mm [2 inches] to provide better conveying of tall boxes. This change increases the minimum box height that can be taped to 190mm [7-1/4 inches].

Disassemble – Figure 13-9

1. It is first necessary to raise the top taping head. Utilize the height adjustment crank and move the upper taping head to the fully raised position.
2. Remove and retain the screw (A), cap washer (B) and spacer (C) from the front and rear arm assembly pivots.
3. Lift belt drive assembly (D) up off the arm assembly pivots.

Reassemble – Figure 13-10

4. Reassemble the spacer (C) onto the front and rear arm assembly pivots.
5. Install the belt drive assembly (D) onto the pivots and secure with the cap washers (B) and screws (A).

Note – Both drive belt assemblies must be installed at the same operating height.

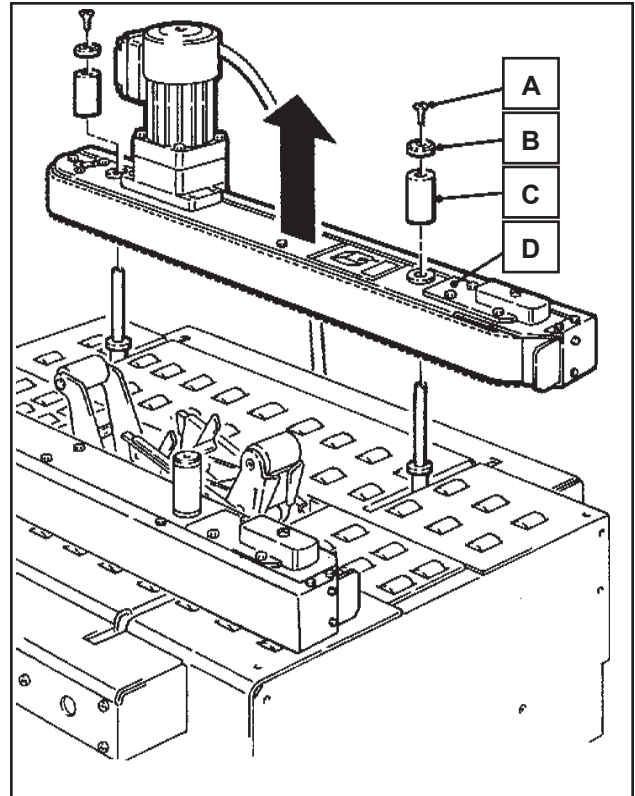

Figure 13-9 – Drive Belt Assembly, Disassembly

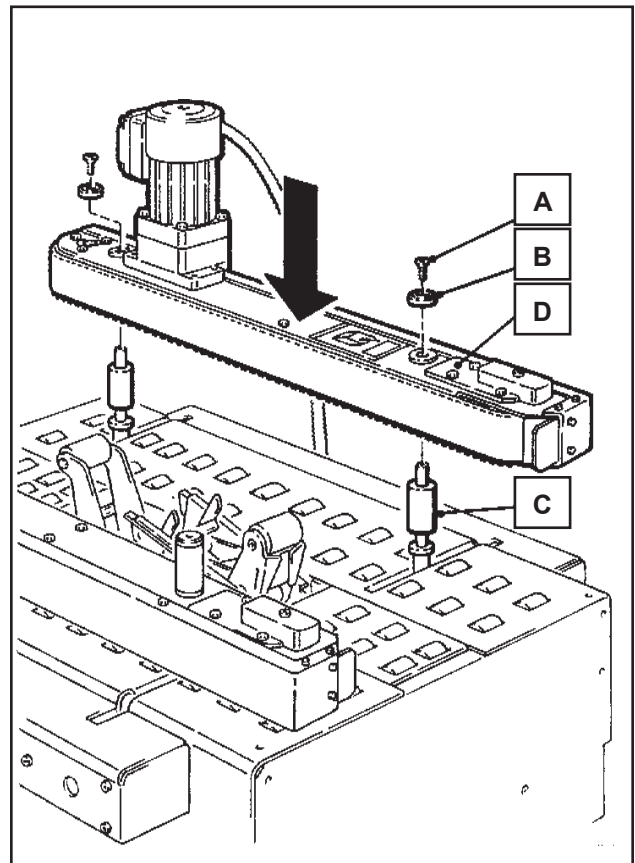

Figure 13-10 – Drive Belt Assembly, Reassembly

Special Set-Up Procedure (continued)



WARNING

- **To reduce the risk associated with mechanical and electrical hazards:**
 - Allow only properly trained and qualified personnel to operate and service this equipment.



WARNING

- **To reduce the risk associated with muscle strain:**
 - Use the appropriate rigging and material handling equipment when lifting or repositioning this equipment.
 - Use proper body mechanics when removing or installing taping heads that are moderately heavy or may be considered awkward to lift.

13.11.4 Box Height Range

(Outer Column – Re-Positioning)

Moving the outer columns to the upper set of mounting holes increases the maximum box size (height) handled by the case sealer from 620mm [24-1/2 inches] to 725mm [28-1/2 inches].

Note – this also increases the minimum box height from 120mm [4-3/4 inches] to 210mm [8-1/4 inches].

To Re-position the outer columns:

1. Remove special nut from the bottom of each column lead screw. **Figure 13-11A.**
2. Remove plastic column cap from the top of each outer column as shown in **Figure 13-11B.**
3. Crank upper assembly up, out of plastic nuts. Lift upper assembly up and out of outer columns. Be careful not to damage lead screws - **Figure 13-11C.**

13.11.4 Special Set-Up Procedure (continued)

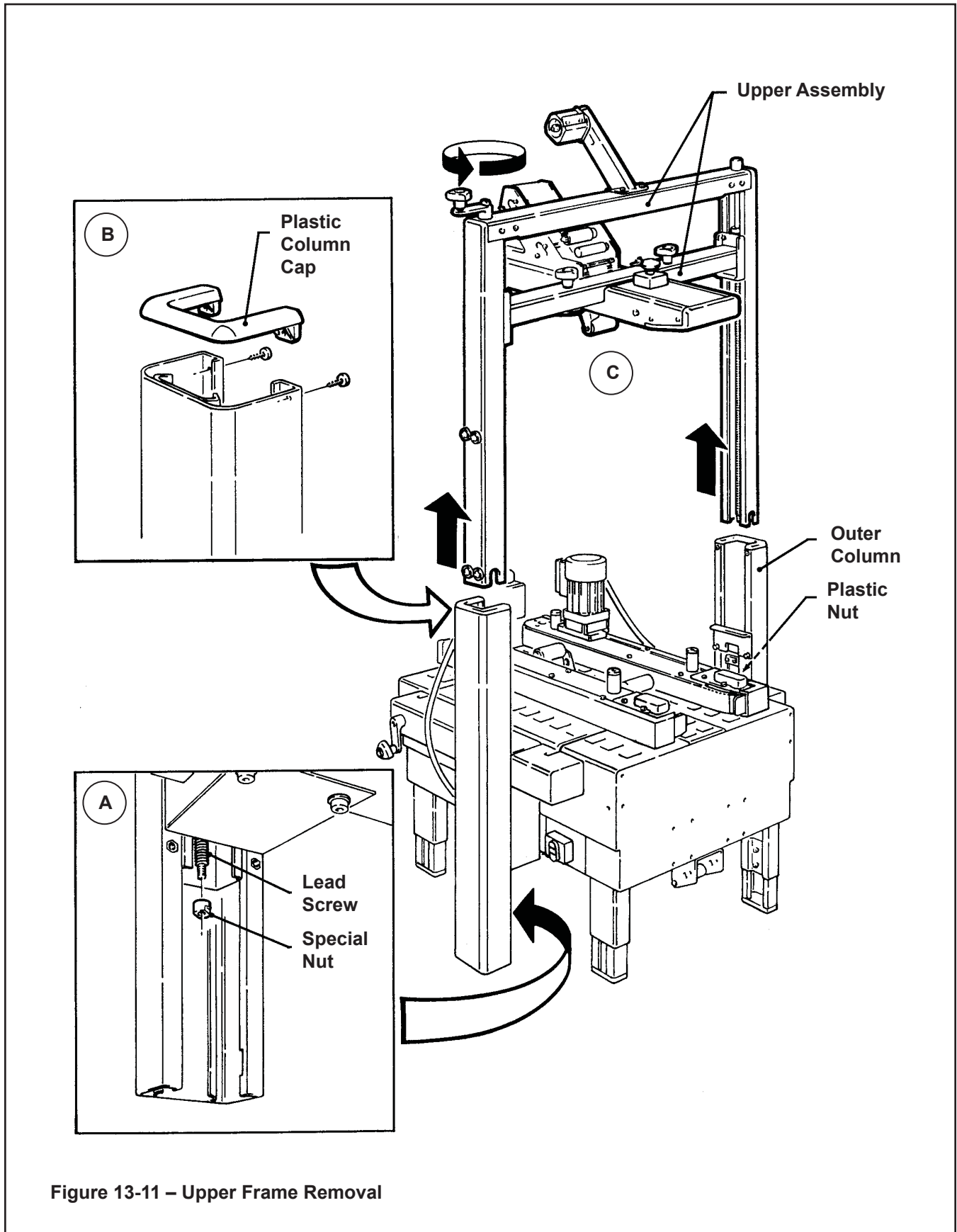

Figure 13-11 – Upper Frame Removal

13-MAINTENANCE AND REPAIRS (continued)

13.11.4 Special Set-Up Procedure (continued)

4. Remove M6 x 16 hex hd screw, special washer and drive belt width adjustment crank - **Figure 13-12.**
5. Remove side covers (2) from each side of machine bed - **Figure 13-12.**
6. Remove chain. If necessary, slip width adjustment crank on shaft and rotate until chain master link is in convenient position for removal.

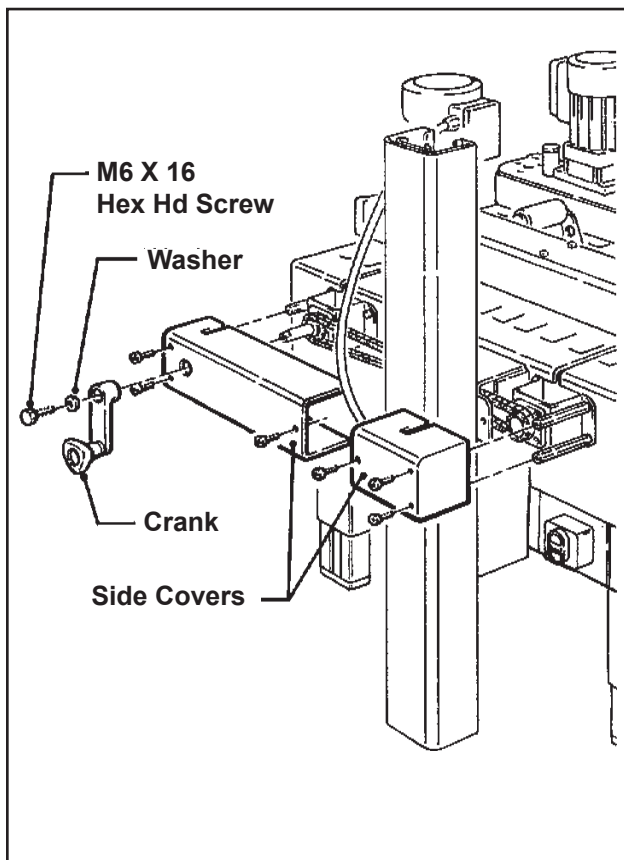

Figure 13-12 – Crank/Chain Guards

Important – Before removing chain, mark both front and rear sprockets/chain with chalk or paint to be sure sprockets/chain when re-assembled, will be in same position as before disassembly. **Figure 13-13A** and **Figure 13-11B.** Do not rotate sprockets once chain is removed. (This would result in the right and left drive assemblies not being parallel.)

Remove chain master link and remove chain. **Figure 13-13C.**

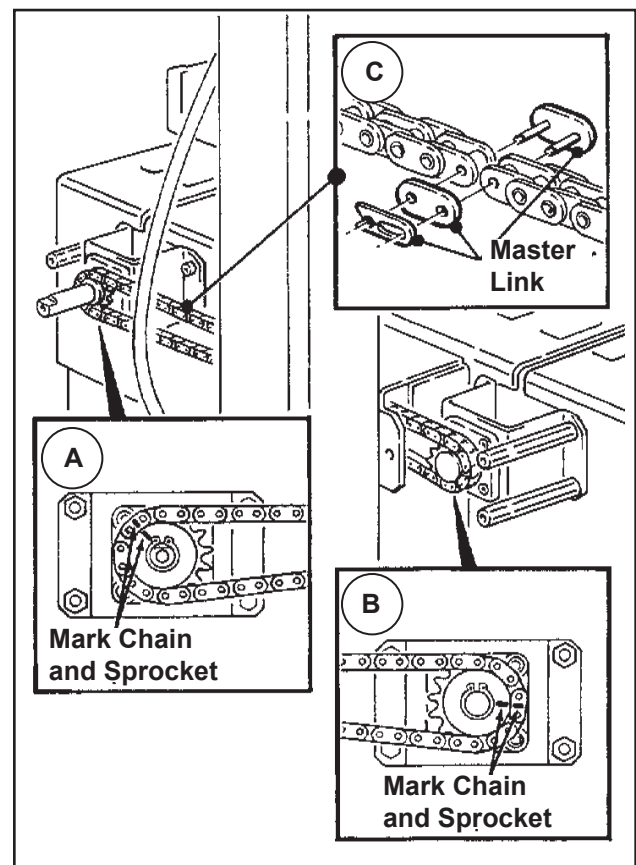

Figure 13-13 – Chain Removal

13-MAINTENANCE AND REPAIRS (continued)

13.11.4 Special Set-Up Procedure (continued)

7. Remove fasteners (M8 x 16 socket head screws and M6 plain washers) that attach column spacers to machine bed and remove spacers/outer columns from machine bed. **Figure 13-14A.**
8. Remove fasteners (M8 x 20 socket head screws) that attach spacers to columns, move spacer down 100 mm [4 inches] to lower set of mounting holes and re-attach spacers to columns. **Figure 13-14B.**
9. Reverse procedure to reassemble machine.

Note – When installing upper assembly back into machine (removed in Step 3), slide upper assembly down into outer columns until lead screws contact plastic nuts and support upper assembly. Then, slowly turn height adjustment crank counterclockwise until two "clicks" are heard, one at each plastic nut. Now the upper assembly can be cranked down (turn height adjustment crank clockwise) for installation of special nut on bottom of each lead screw.

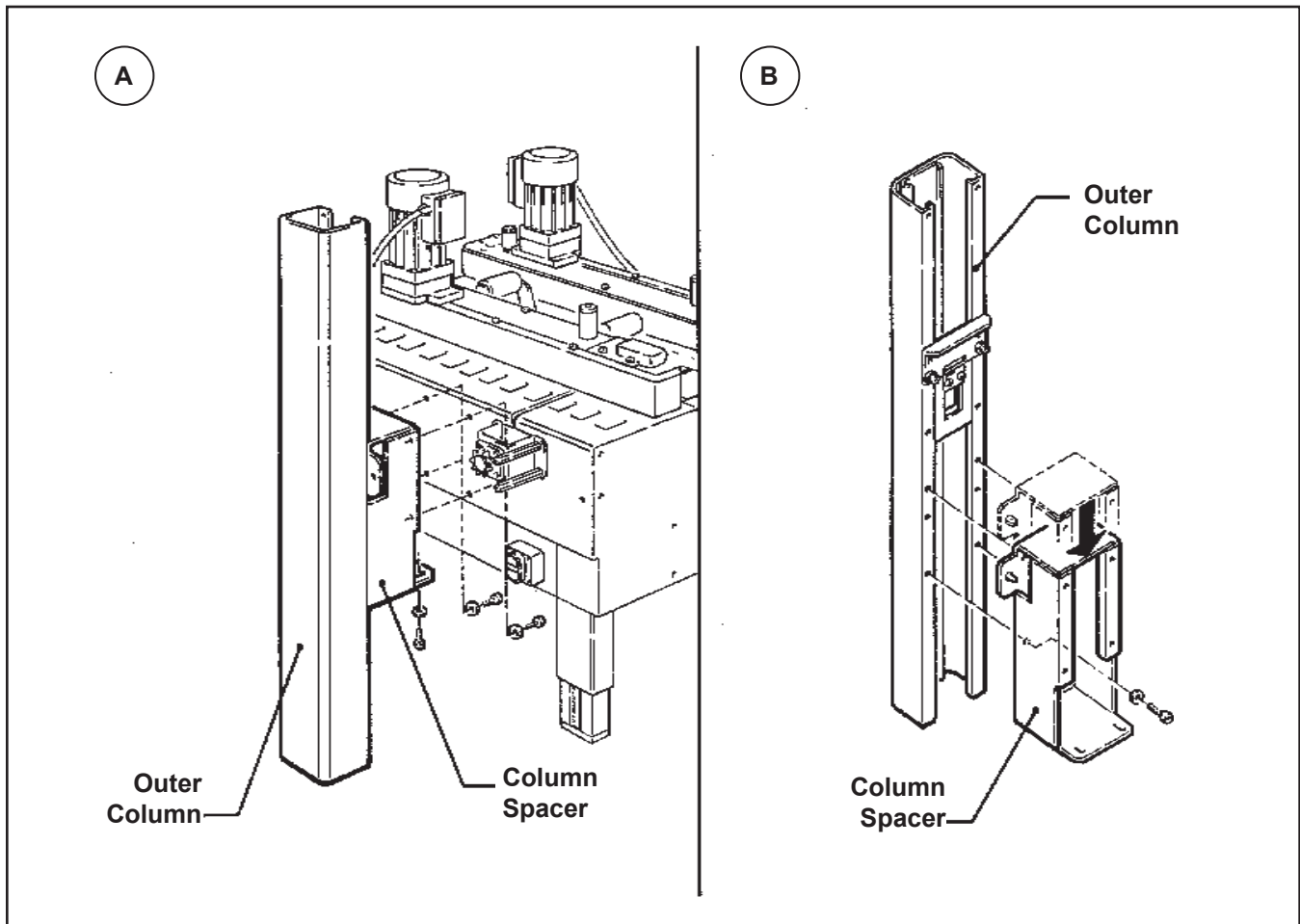

Figure 13-14 – Column Spacers/Columns

THIS PAGE IS BLANK

THIS PAGE IS BLANK

14.1 Information for Disposal of Machine (ELV)

The machine is composed of the following materials:

- Steel structure
- Nylon rollers
- Drive belts in PVC
- Nylon pulleys

For machine disposal, follow the regulations published in each country.

14.2 Emergency Procedures

In case of danger/fire:
Disconnect plug of power cable from power supply.
(Figure 14-1)

IN CASE OF FIRE

Use a fire extinguisher that is rated for electrical fires
(Figure 14-2).

15.1 Statement of Conformity

Not Applicable.

15.2 Emission of Hazardous Substances

Nothing to report

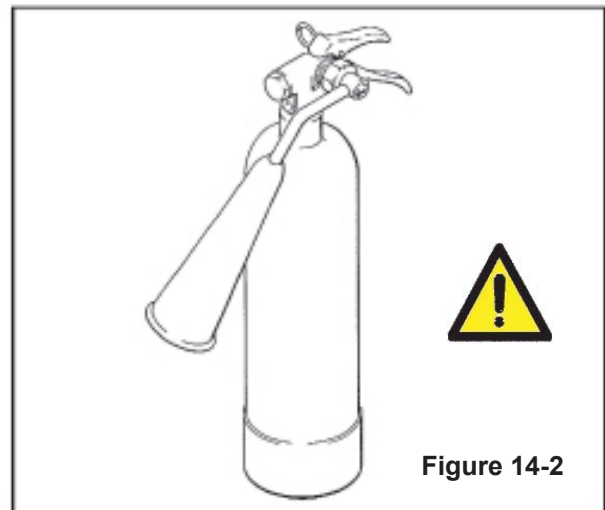
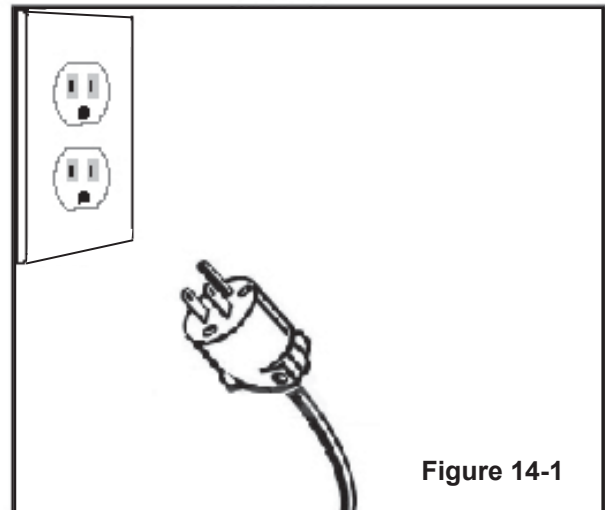

THIS PAGE IS BLANK

16-TECHNICAL DIAGRAMS

16.1 Electric Diagram

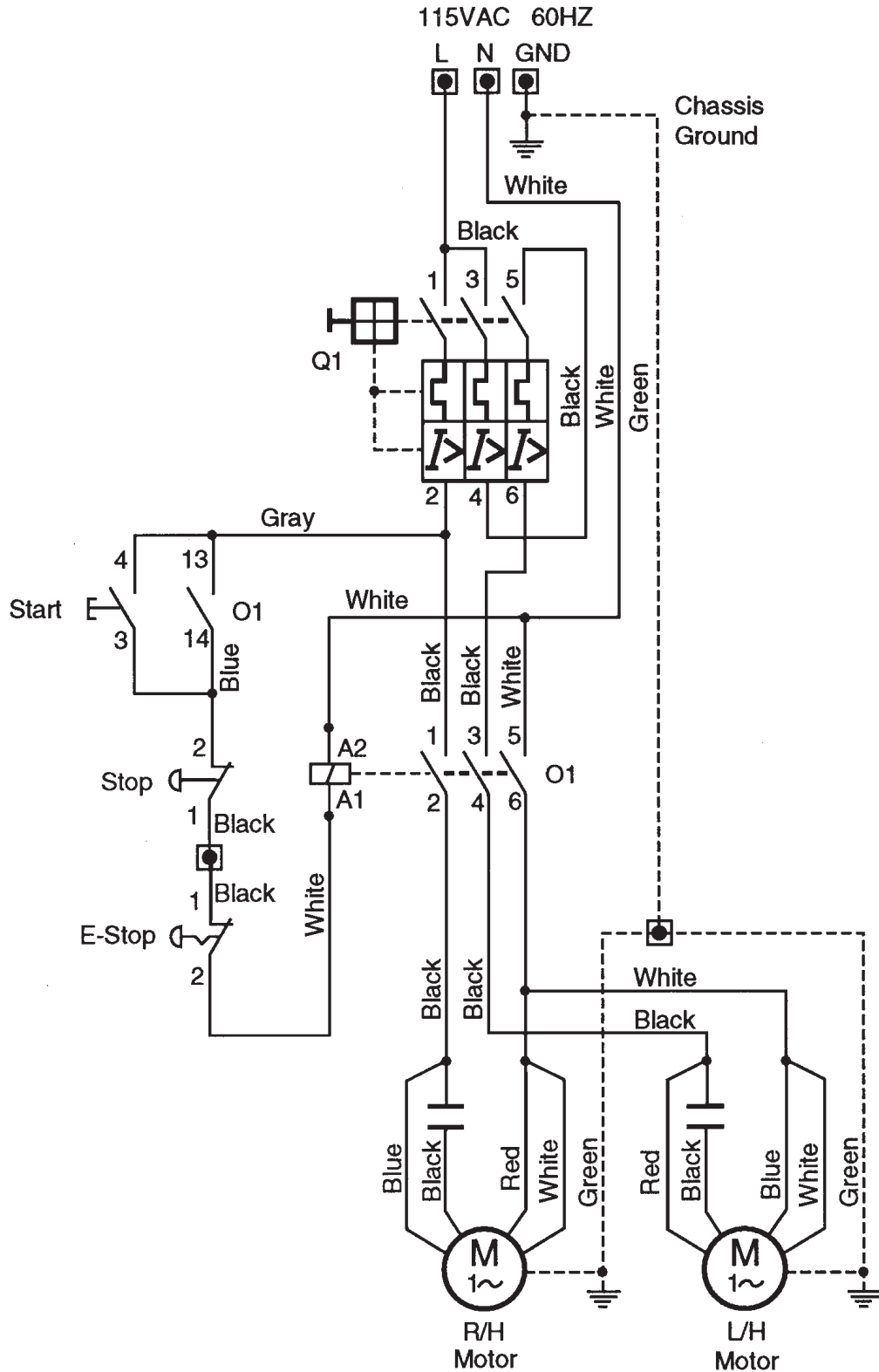

16.2 Spare Parts Order

Replacement Parts Ordering Information and Service

Refer to the first page of this instruction manual "Replacement Parts and Service Information".

Order parts by quoting the following information:

(Refer to the Identification Plate on the Machine)

- MACHINE MODEL
- SERIAL NUMBER
- FIGURE NO.
- POSITION
- 3M PART NO. (11 DIGITS)
- DESCRIPTION
- QUANTITY

Refer to Manual 2 for recommended taping head spare parts.

Important!

The machine is constantly revised and improved by our designers. The spare parts catalogue is also periodically updated. It is very important that all the orders of spare parts make reference to the serial number of the machine (located on the identification plate on the machine).

The manufacturer reserves the right to modify the machine at any time without notice.

It is suggested that the following spare parts be ordered and kept on hand.

800a

Qty.	3M-Part Number	Description
2	78-8076-5452-6	Belt-Drive W/Hook

See Manual 2

Tool Kit

A tool kit, part number TBA, is available as a stock item. The kit contains the necessary open end and hex socket wrenches for use with the metric fasteners on the case sealer. The threading tool, part number 78-8076-4726-4, contained in above kit is also available as a replacement stock item.

Label Kit

In the event that any labels are damaged or destroyed, they must be replaced to ensure operator safety. A label kit, part number 78-8113-6744-6, is available as a stock item. It contains all the safety labels used on the 800a Adjustable Case Sealer.

800a Adjustable Case Sealer, Type 40800 Frame Assemblies

To Order Parts:

1. Refer to first illustration, **Frame Assemblies**, for the **Figure Number** that identifies a specific portion of the machine.
2. Refer to the appropriate **Figure or Figures** to determine the parts required and the parts reference number.
3. The Parts List that follows each illustration, includes the **Reference Number, Part Number** and **Part Description** for the parts on that illustration.

Note – The complete description has been included for standard fasteners and some commercially available components. This has been done to allow obtaining these standard parts locally, if desired.

4. Order parts by Part Number, Part Description and Quantity required. Also include the model/machine name, machine type, and serial number that are located on the identification plate.
5. Refer to the first page of this instruction manual “**Replacement Parts and Service Information**” for replacement parts ordering information.

Important – Not all the parts listed are normally stocked items. Some parts or assemblies shown are available only on special order. Contact 3M/Tape Dispenser Parts to confirm item availability.

Options and Accessories

For additional information on the options and accessories listed below, contact your 3M Representative.

Part Number	Option/Accessory
78-8052-6553-1	Box Hold Down Attachment
78-8069-3983-7	Caster Kit Attachment
70-8069-3924-1	Conveyor Extension Attachment
78-8069-3926-6	Low Tape Sensor Kit
70-0064-4963-4	AccuGlide 3 Upper Taping Head - 2 inch, Type 10800
70-0064-4962-6	AccuGlide 3 Lower Taping Head - 2 inch, Type 10800
78-8114-0940-4	Three Flap Folder Kit
78-8095-4854-4	2 Inch Tape Edge Fold Kit (Upper)
78-8095-4855-1	2 Inch Tape Edge Fold Kit (Lower)

THIS PAGE IS BLANK

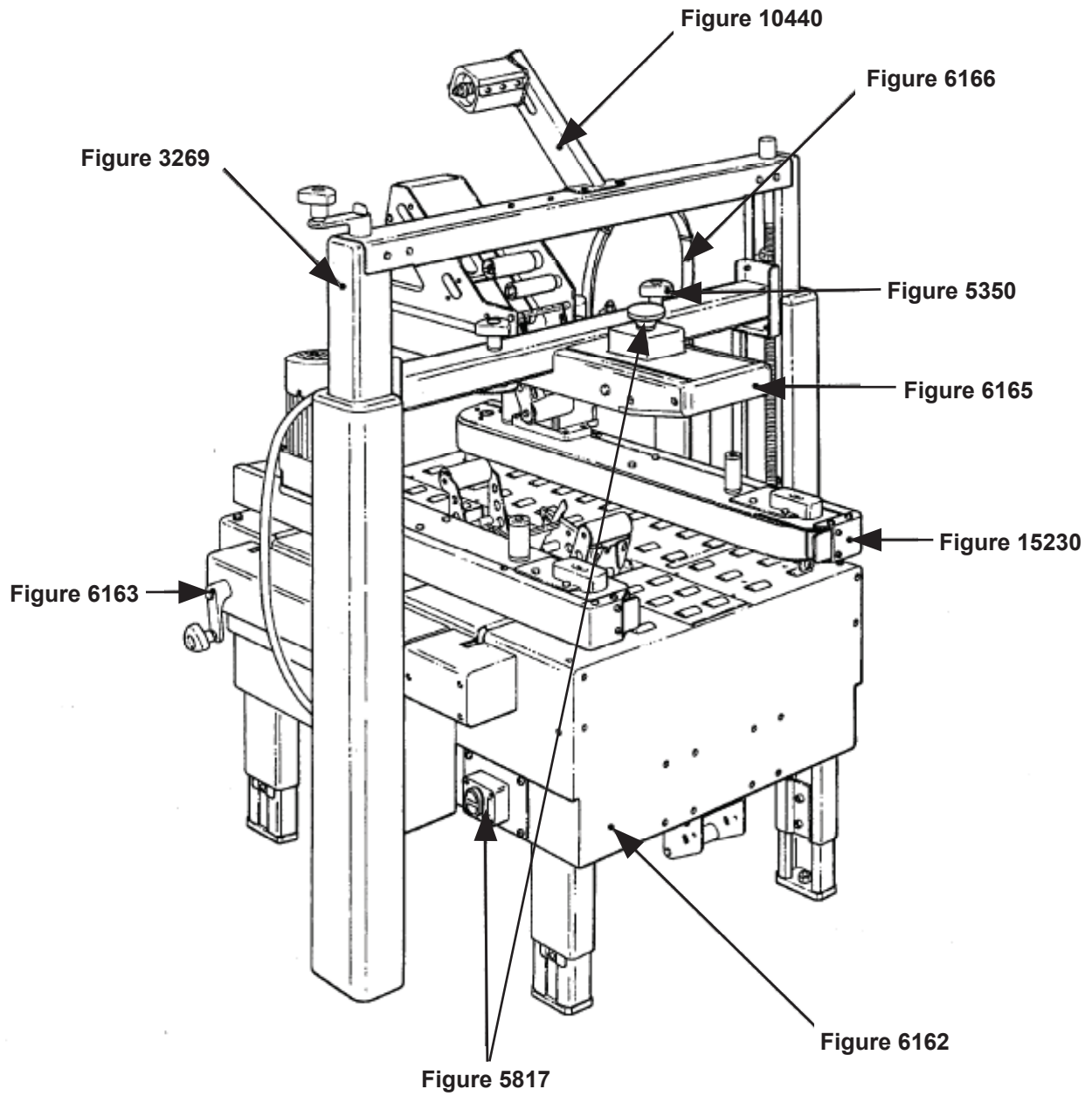

**Frame
Assemblies**

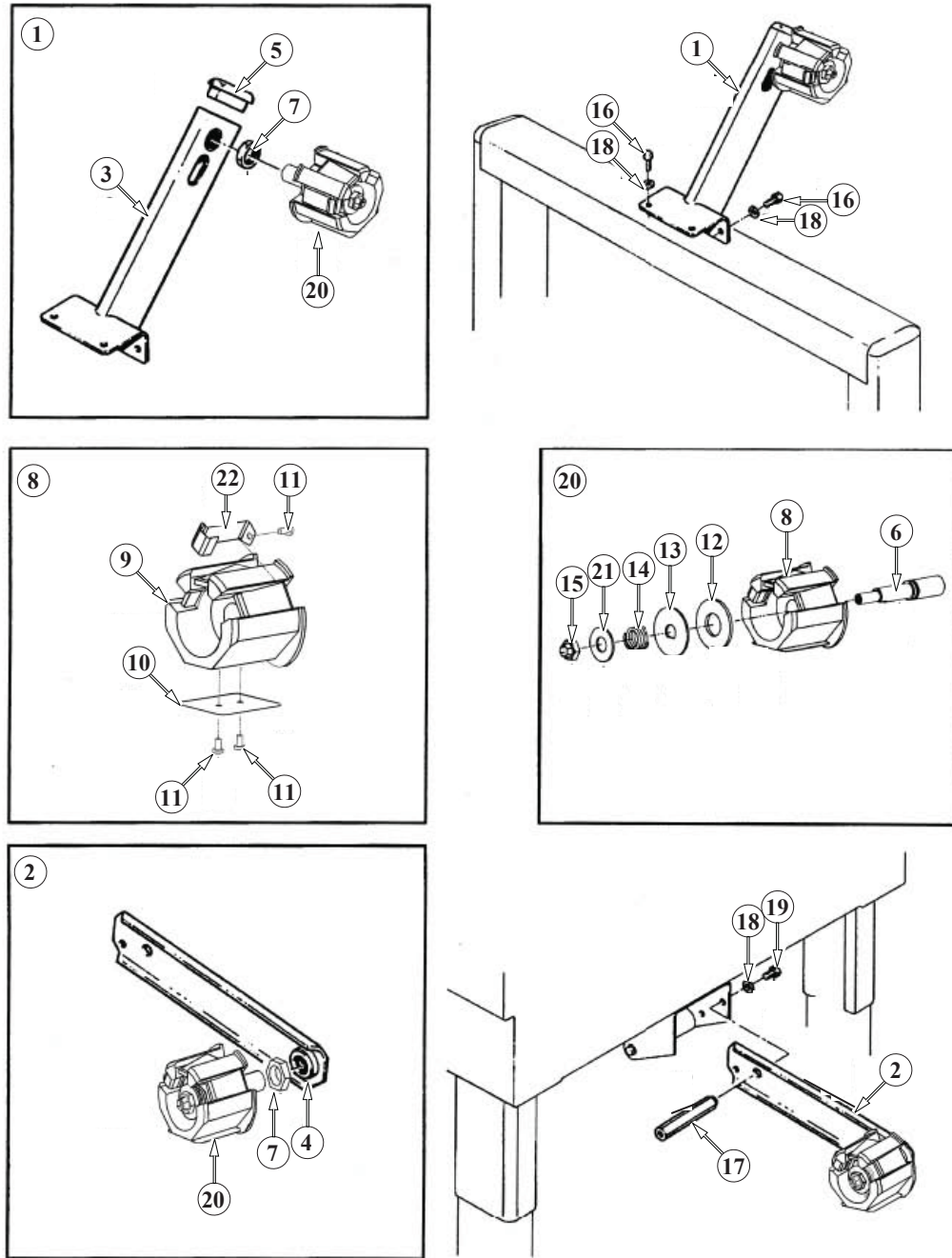

Figure 10440

Figure 10440

Ref. No.	3M Part No.	Description
10440-1	78-8076-4633-2	Tape Roll Bracket Assembly
10440-2	78-8070-1565-2	Tape Drum Bracket Assembly
10440-3	78-8070-1566-0	Bracket – Tape Drum
10440-4	78-8070-1395-4	Bracket – Bushing Assembly
10440-5	78-8070-1568-6	Cap – Bracket
10440-6	78-8076-4519-3	Shaft – Tape Drum
10440-7	78-8017-9169-6	Nut – M18 x 1
10440-8	78-8098-8827-0	Tape Drum Sub-Assembly - 2 Inch
10440-9	78-8098-8749-6	Tape Drum
10440-10	78-8098-8817-1	Leaf Spring
10440-11	26-1002-5753-9	Screw – Self Tapping
10440-12	78-8060-8172-1	Washer – Friction
10440-13	78-8052-6271-0	Washer – Tape Drum
10440-14	78-8100-1048-4	Spring – Core Holder
10440-15	78-8017-9077-1	Nut – Self Locking, M10 x 1
10440-16	78-8032-0375-7	Screw – Hex Hd, M6 x 16
10440-17	78-8070-1215-4	Spacer – Stud
10440-18	26-1000-0010-3	Washer – Flat, M6
10440-19	78-8010-7169-3	Screw – Hex Hd, M6 x 12
10440-20	78-8060-8474-1	Tape Drum Assembly – 2 Inch Head
10440-21	26-1004-5510-9	Washer - Plain, M10
10440-22	78-8098-8816-3	Latch - Tape Drum

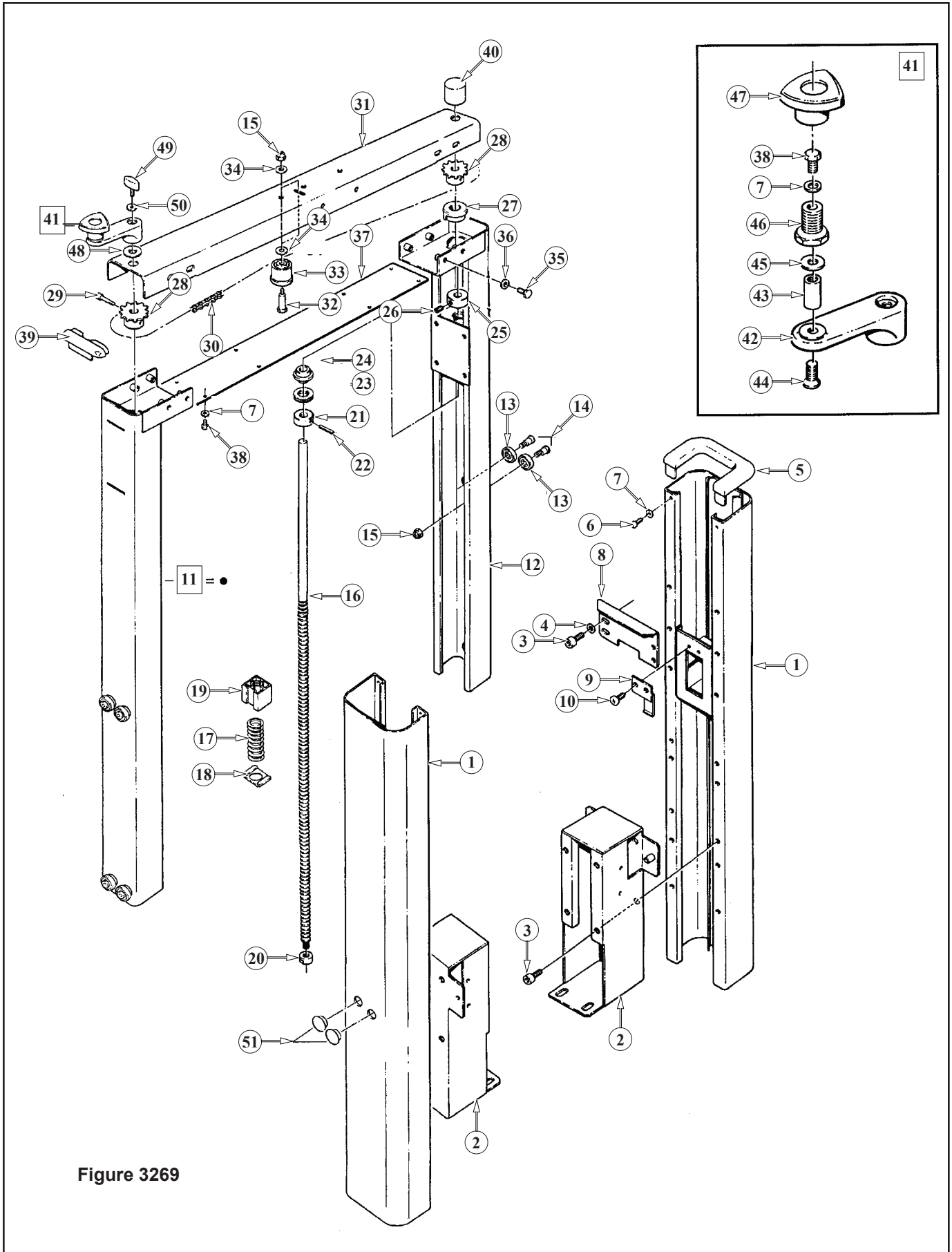

Figure 3269

800a

Figure 3269

Ref. No.	3M Part No.	Description
3269-1	78-8060-8489-9	Column – Outer
3269-2	78-8076-5426-0	Plate
3269-3	26-1003-7964-8	Screw – Soc Hd, M8 x 20
3269-4	78-8017-9318-9	Washer – Plain 8 mm
3269-5	78-8060-8491-5	Cap – Column
3269-6	26-1002-4955-1	Screw – Self-Tap, 8P x 13
3269-7	78-8005-5740-3	Washer – Plain 4 mm
3269-8	78-8060-8492-3	Stop – Height
3269-9	78-8076-5482-3	Plate – Nut Stop
3269-10	78-8060-8087-1	Screw – M5 x 10
3269-11	78-8060-8494-9	Column Assembly – Inner
3269-12	78-8060-8495-6	Column – Inner
3269-13	78-8054-8617-8	Bearing – Special
3269-14	78-8054-8589-9	Screw – Special
3260-15	26-1003-6916-9	Nut – Locking, M6, Plastic Insert
3269-16	78-8060-8496-4	Lead Screw
3269-17	78-8054-8969-3	Spring
3269-18	78-8054-8970-1	Bed Plate For Spring
3269-19	78-8054-8571-7	Nut – Plastic
3269-20	78-8054-8968-5	Nut – Special
3269-21	78-8054-8585-7	Collar
3269-22	78-8054-8586-5	Pin
3269-23	78-8054-8584-0	Spacer
3269-24	78-8054-8583-2	Bushing
3269-25	78-8060-8497-2	Bushing – Lead Screw
3269-26	78-8059-5617-0	Set Screw – M6 x 8
3269-27	78-8060-8498-0	Bushing – Inner Column
3269-28	78-8060-8499-8	Sprocket – 3/8 Inch, Z=13
3269-29	26-1003-7946-5	Screw – Soc Hd, M4 x 25
3269-30	78-8076-4818-9	Chain – 3/8 Inch, Pitch 197
3269-31	78-8113-6803-0	Housing – Chain, W/English Language Label
3269-32	78-8060-7878-4	Idler Screw
3269-33	78-8070-1503-3	Roller – Chain Tensioning
3269-34	78-8042-2919-9	Washer – Triple, M6
3269-35	26-1003-5829-5	Screw – Hex Hd, M6 x 12
3269-36	26-1000-0010-3	Washer – Flat M6
3269-37	78-8076-5428-6	Cover
3269-38	78-8010-7157-8	Screw – Hex Hd, M4 x 10
3269-39	78-8070-1505-8	Cap – Inner Column
3269-40	78-8070-1506-6	Cover – Screw
3269-41	78-8076-4807-2	Crank Assembly
3269-42	78-8076-5422-9	Crank
3269-43	78-8070-1509-0	Shaft – Crank
3269-44	26-1005-5316-8	Screw – Flat Hd Hex Dr, M5 x 16
3269-45	78-8070-1510-8	Washer – Nylon, 7 x 15 x 1
3269-46	78-8070-1511-6	Bushing
3269-47	78-8070-1512-4	Knob – VTR-B-M12
3269-48	78-8076-4800-7	Washer – Crank
3269-49	78-8076-4821-3	Key – Stop
3269-50	78-8076-4809-8	Washer – Crank
3269-51	78-8054-8821-6	End – Cap

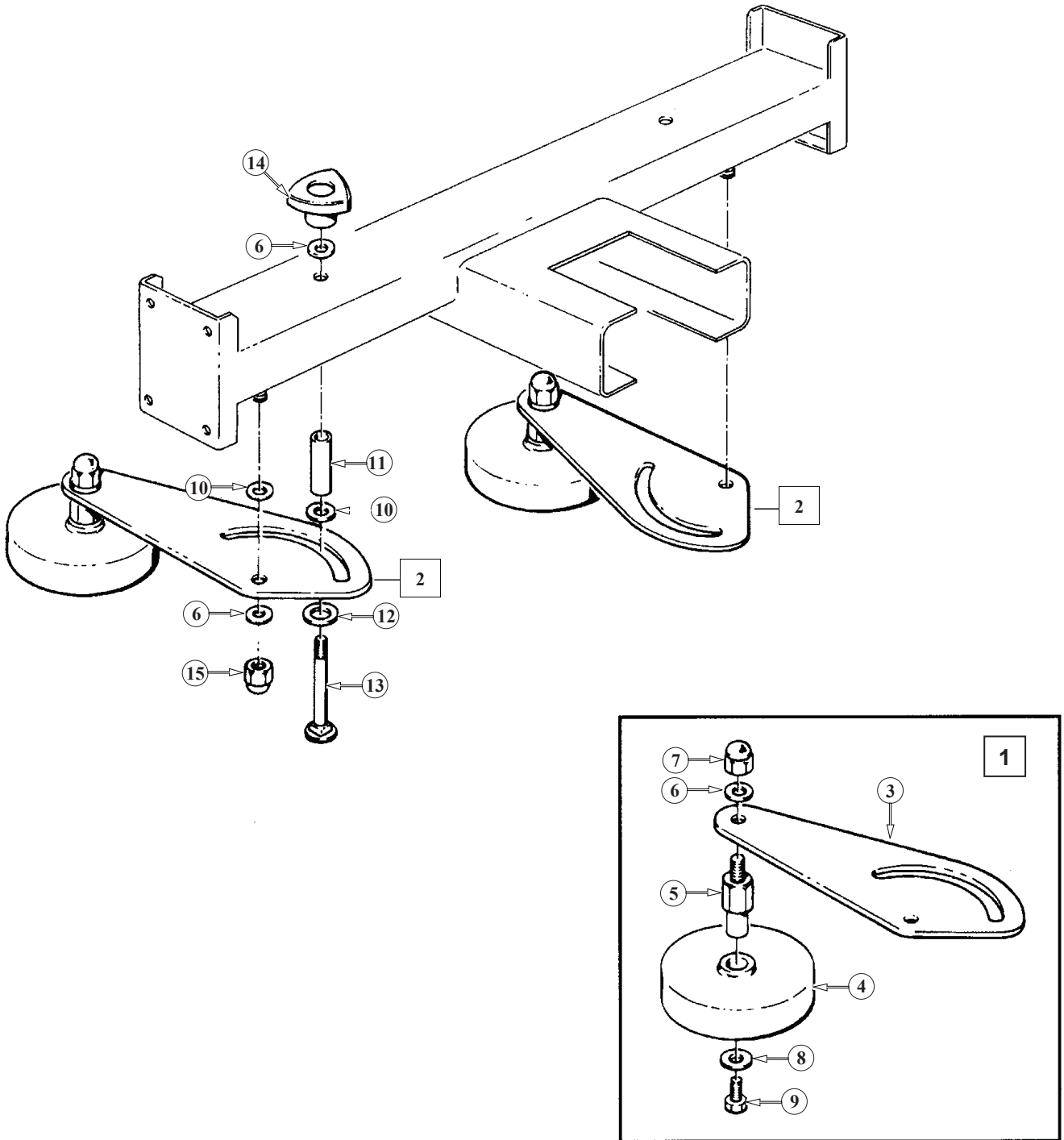

Figure 5350

800a

Figure 5350

Ref. No.	3M Part No.	Description
5350-1	78-8100-0876-9	Compression Roller Assembly – R/H
5350-2	78-8100-0877-7	Compression Roller Assembly – L/H
5350-3	78-8070-1559-5	Support – Compression Roller
5350-4	78-8054-8974-3	Pressure Roller
5350-5	78-8070-1560-3	Stud – Roller Mounting
5350-6	26-1004-5510-9	Washer – Friction M10
5350-7	78-8070-1561-1	Nut – M10
5350-8	26-1004-5507-5	Washer – M8
5350-9	26-1003-5841-0	Screw – M8 x 16
5350-10	78-8017-9074-8	Washer – Nylon, 15 mm
5350-11	78-8070-1562-9	Tube – Roller Support
5350-12	12-7991-1752-3	Washer – Plain, M14
5350-13	78-8070-1563-7	Screw – M10 x 80
5350-14	78-8070-1549-6	Knob – VTR-B-M10
5350-15	26-1003-6918-5	Nut – Plastic Insert, M10 Hex Flange

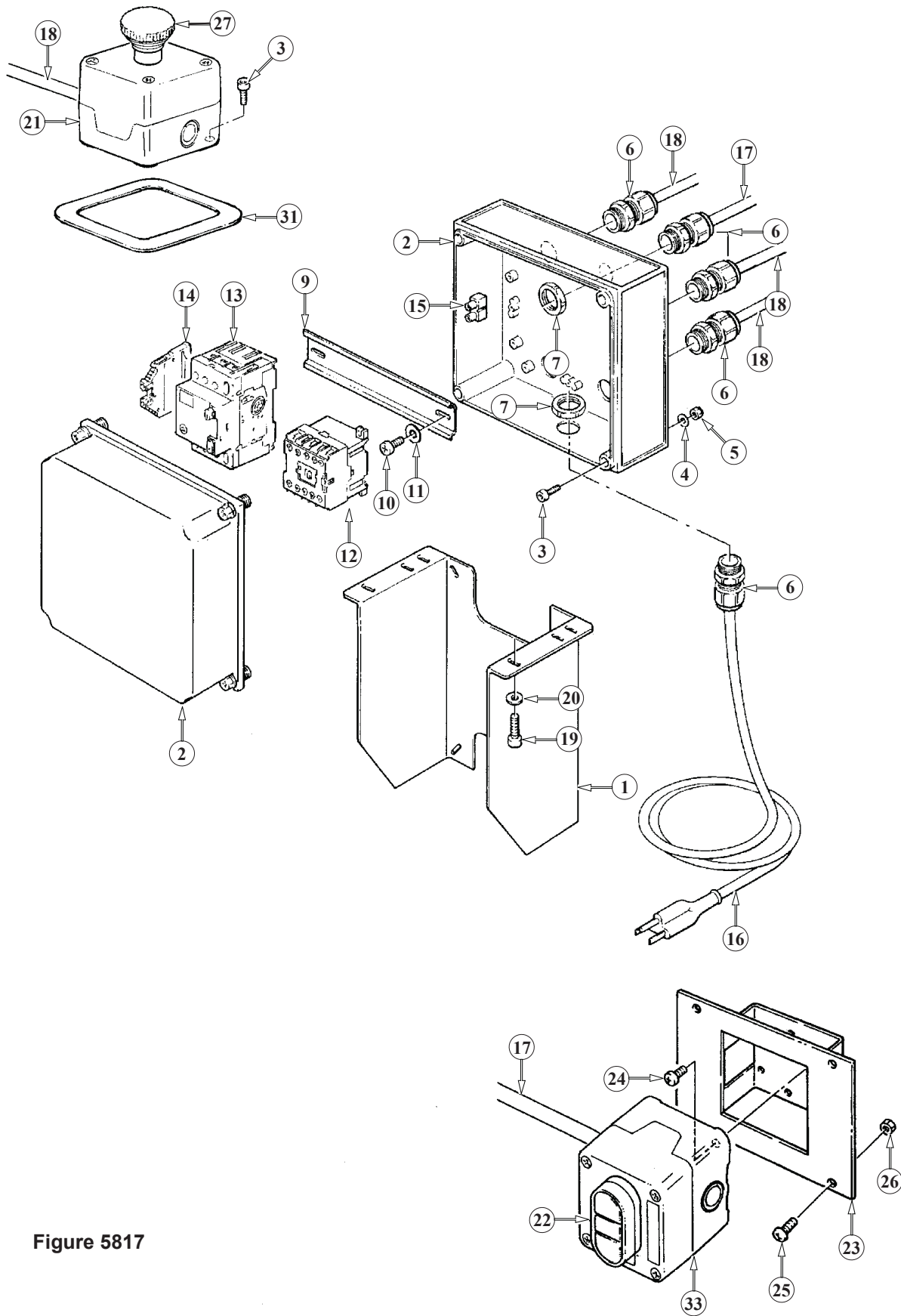

Figure 5817

800a**Figure 5817**

Ref. No.	3M Part No.	Description
5817-1	78-8094-6379-3	Support – Box
5817-2	78-8113-6759-4	Box – W/English Language Label
5817-3	78-8094-6381-9	Screw – Soc Hd, Hex Hd, M4 x 15
5817-4	78-8005-5740-3	Washer – Plain, 4 mm
5817-5	26-1003-6914-4	Nut – Plastic Insert, M4
5817-6	78-8076-4715-7	Cord Grip
5817-7	78-8076-5211-6	Set Nut – GMP 13.5
5817-9	78-8094-6382-7	Guide – Mounting
5817-10	78-8028-8208-0	Screw – 6P x 9,5
5817-11	78-8017-9018-5	Contactora - Allen Bradley m05
5817-12	78-8094-6383-5	Circuit Breaker - Allen Bradley 140m -C2E 60HZ
5817-13	78-8076-5378-3	Circuit Breaker – Sprecher and Schuh, KTA-3-25
5817-14	78-8094-6384-3	Clamp – VGPE 4/6
5817-15	78-8076-4968-2	Terminal
5817-16	78-8028-7909-4	Power Cord U.S.A.
5817-17	78-8100-1038-5	Cable – 3 x 20 AWG, 5 MT
5817-18	78-8060-8053-3	Wire – 3-Pole, 5 Meters Length
5817-19	26-1003-7957-2	Screw – Soc Hd, Hex Hd, M6 x 16
5817-20	26-1000-0010-3	Washer – Flat, M6
5817-21	78-8076-5194-4	Box – E-Stop
5817-22	78-8094-6386-8	Switch – On/Off, Sprecher and Schuh, DM3N-C-01/10
5817-23	78-8100-1039-3	Support – On/Off Switch
5817-24	78-8017-9257-9	Screw – Phillips Hd, M4 x 10
5817-25	78-8060-8087-1	Screw – M5 x 10
5817-26	78-8010-7417-6	Nut -
5817-27	26-1014-5845-8	E-Stop – W/Latch and Contact Block, 800EM-MTS44-3LX01
5817-31	78-8100-1234-0	Collar
5817-33	78-8114-4896-4	Box – On/Off, Grey

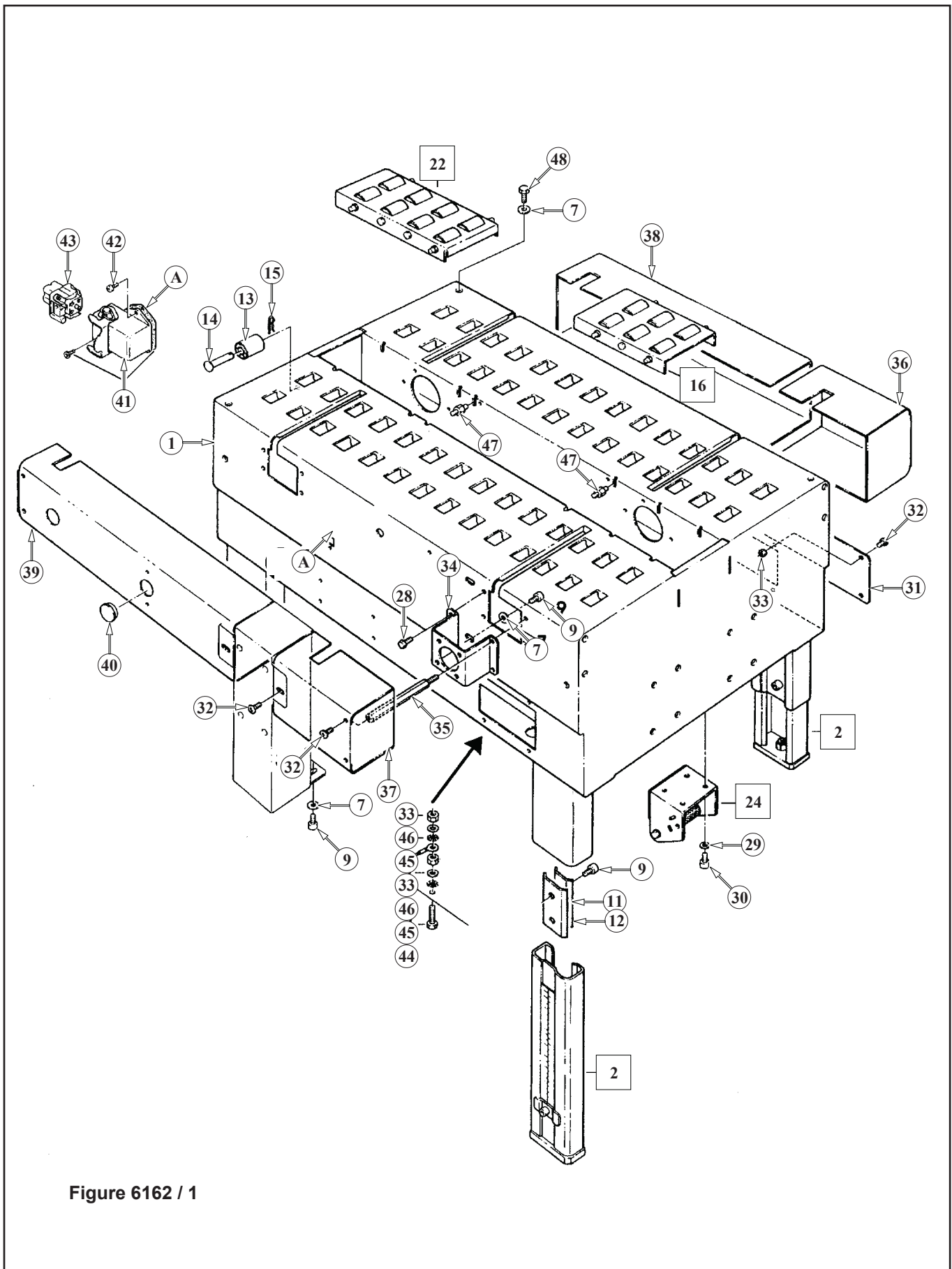

Figure 6162 / 1

Figure 6162 / 1

Ref. No.	3M Part No.	Description
6162-1	78-8076-5380-9	Bed – Conveyor
6162-2	78-8076-5381-7	Leg Assembly – Inner, W/Stop
6162-3	78-8076-5382-5	Leg – Inner
6162-4	78-8060-8480-8	Pad – Foot
6162-5	78-8055-0867-4	Screw – Hex Hd, M8 x 30
6162-6	78-8017-9313-0	Nut – Self-Locking, M8
6162-7	78-8017-9318-9	Washer – Plain 8 mm
6162-8	78-8076-5383-3	Stop – Leg
6162-9	26-1003-7963-0	Screw – Soc Hd, M8 x 16
6162-10	78-8060-8481-6	Label – Height
6162-11	78-8052-6676-0	Clamp – Outer
6162-12	78-8052-6677-8	Clamp – Inner
6162-13	78-8060-7693-7	Roller – 32 x 38
6162-14	78-8076-5384-1	Shaft – Roller
6162-15	78-8076-5385-8	Spring
6162-16	78-8094-6100-3	Conveyor Assembly – Front
6162-17	78-8076-5387-4	Conveyor – Front
6162-18	78-8091-0780-4	Shaft – Central Roller
6162-19	78-8091-0781-2	Shaft – Side Roller
6162-20	26-1003-5828-7	Screw – Hex Hd, M6 x 10
6162-21	78-8076-5389-0	Mounting – Conveyor
6162-22	78-8094-6101-1	Conveyor Assembly – Rear
6162-23	78-8076-5391-6	Conveyor – Rear
6162-24	78-8076-5392-4	Support – Tape Drum
6162-25	78-8060-8483-2	Support – Outboard Roll Mount
6162-26	78-8060-8484-0	Shaft – Roller
6162-27	78-8060-8485-7	Roller

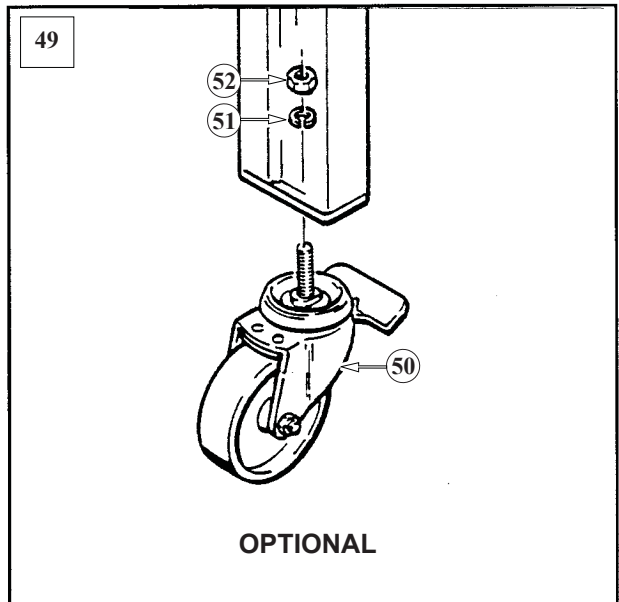
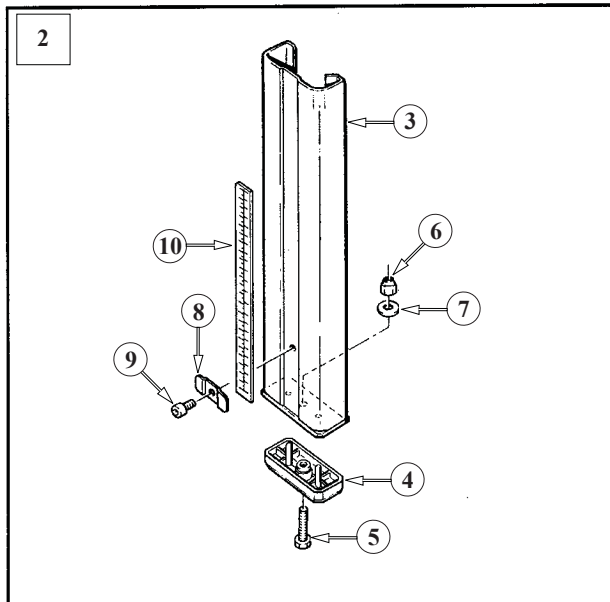
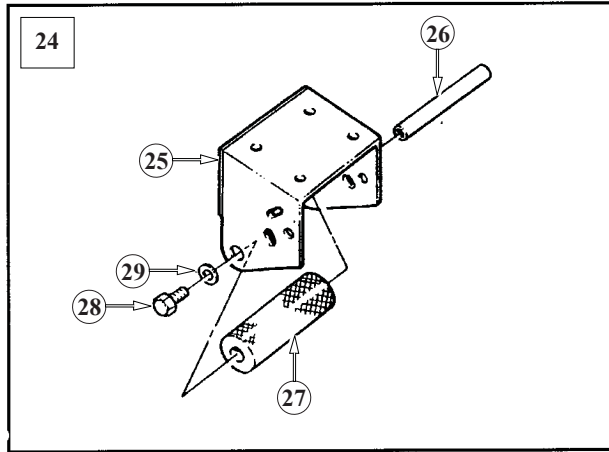
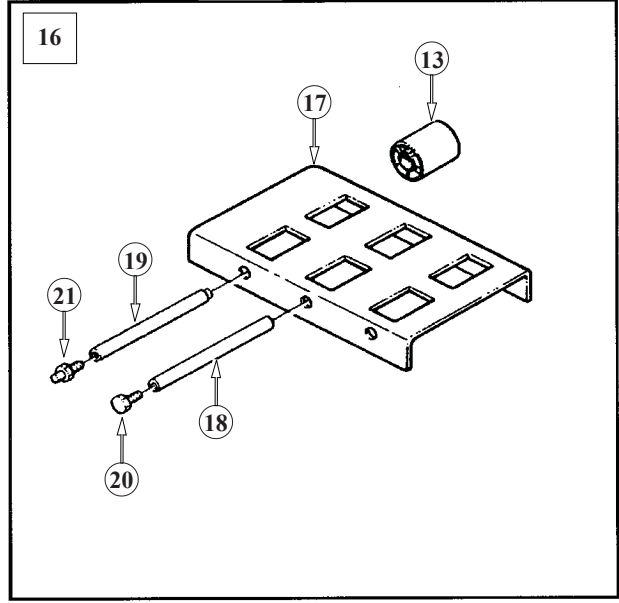
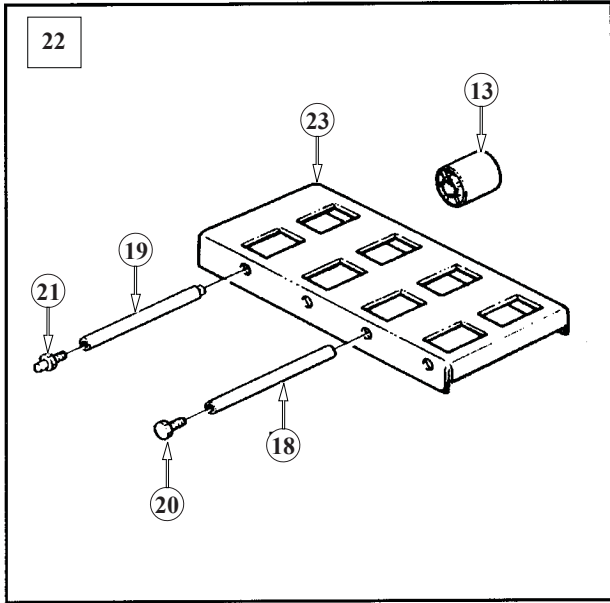

Figure 6162 / 2

800a

Figure 6162 / 2

Ref. No.	3M Part No.	Description
6162-28	78-8032-0375-7	Screw – Hex Hd, M6 x 16
6162-29	26-1000-0010-3	Washer – Flat M6
6162-30	26-1003-7957-2	Screw – Soc Hd Hex Hd, M6 x 16
6162-31	78-8060-8487-3	Cover – Switch
6162-32	78-8060-8087-1	Screw – M5 x 10
6162-33	78-8010-7417-6	Nut – Hex M5
6162-34	78-8076-5393-2	Plate – Tape Bracket Support
6162-35	78-8076-5394-0	Spacer
6162-36	78-8076-5395-7	Cover – Side, Front, R/H
6162-37	78-8076-5396-5	Cover – Side, Front, L/H
6162-38	78-8100-1203-5	Cover – Side, Rear, R/H
6162-39	78-8113-6813-9	Cover – Side, Rear, L/H, W/English Language Label
6162-40	78-8076-4517-7	End Cap – /22 x 1
6162-41	78-8060-7876-8	Cover – Plug Lateral
6162-42	78-8028-8208-0	Screw – 6P x 9,5
6162-43	78-8060-7873-5	Plug – Female
6162-44	78-8060-8488-1	Screw – Hex Hd, M5 x 20
6162-45	78-8046-8217-3	Washer – Special
6162-46	78-8005-5741-1	Washer – Plain M5
6162-47	78-8076-4991-4	Spacer
6162-48	26-1003-5841-0	Screw – M8 x 16
6162-49	78-8098-9076-3	Caster
6162-50	26-1009-9096-4	Caster – Dual Locking
6162-51	26-1009-9094-9	Washer – Spring, Helical, M12
6162-52	26-1009-9095-6	Nut – M12

Front

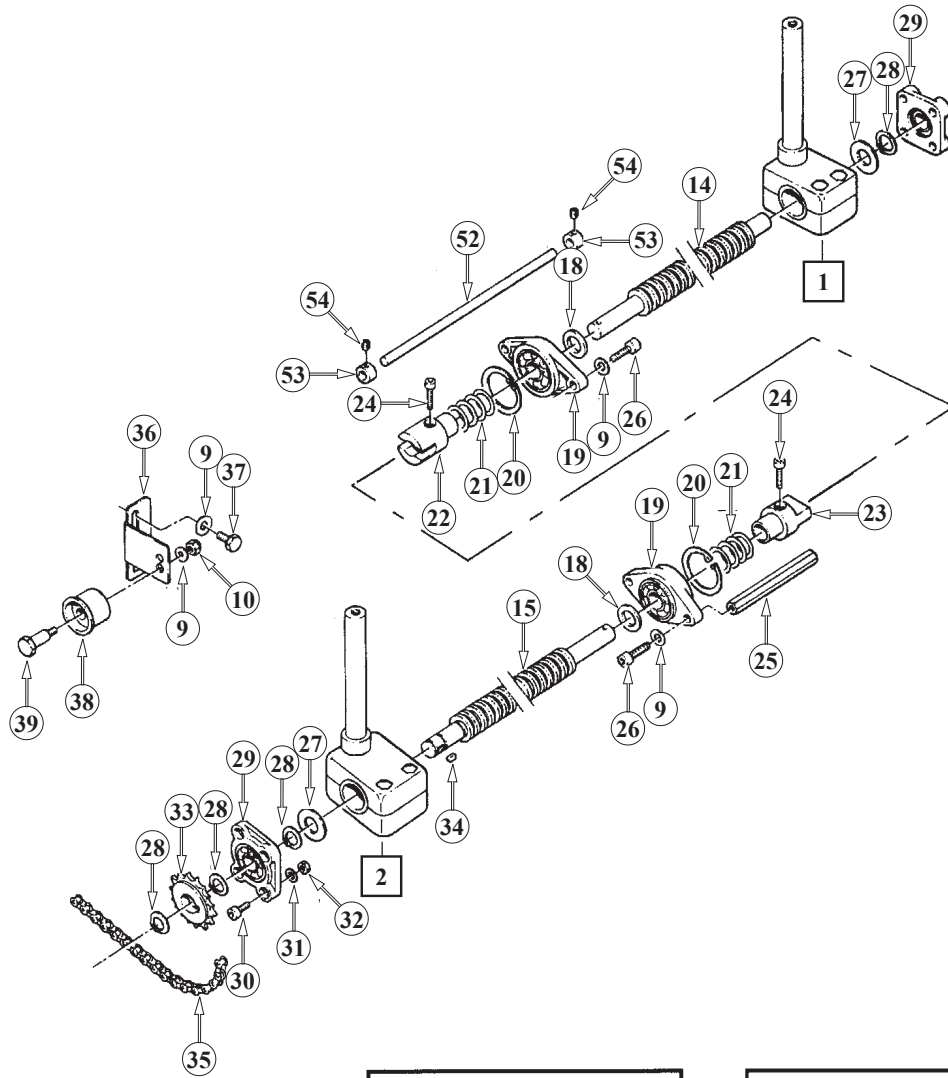

• = Pos.3 and 4
to be ordered
always together

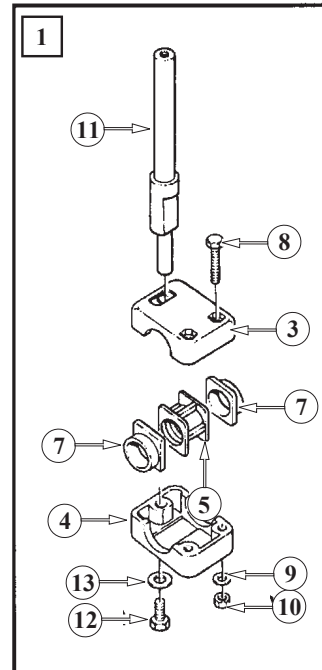
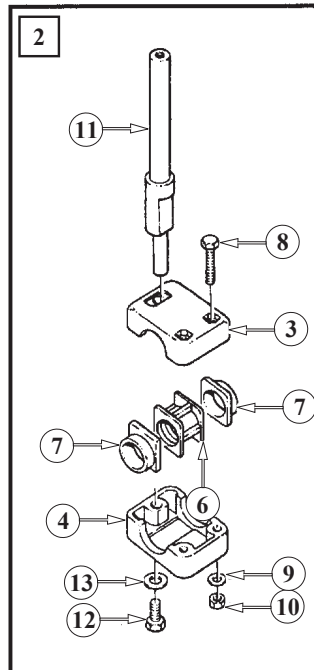

Figure 6163 / 1

Figure 6163 / 1

Ref. No.	3M Part No.	Description
6163-1	78-8100-1229-0	Shaft Assembly – Drive R/H
6163-2	78-8100-1230-8	Shaft Assembly – Drive L/H
6163-3	78-8076-5401-3	Block – Upper
6163-4	78-8076-5402-1	Block – Lower
6163-5	78-8076-5403-9	Nut – Block, R/H
6163-6	78-8076-5404-7	Nut – Block, L/H
6163-7	78-8076-5405-4	Bushing – Block
6163-8	78-8076-5239-7	Screw – Hex Hd, M6 x 50
6163-9	26-1000-0010-3	Washer – Flat M6
6163-10	26-1003-6916-9	Nut – Locking, Plastic Insert M6
6163-11	78-8100-1220-9	Shaft – Drive Mount
6163-12	26-1003-5842-8	Screw – Hex Hd, M8 x 20
6163-13	78-8005-5736-1	Lockwasher – For M8 Screw
6163-14	78-8076-5407-0	Screw – R/H
6163-15	78-8076-5408-8	Screw – L/H
6163-16	78-8076-5409-6	Screw – Handle, R/H
6163-17	78-8076-5410-4	Screw – Handle, L/H
6163-18	78-8076-5411-2	Spacer – Screw
6163-19	78-8076-5412-0	Flange – W/Bearing
6163-20	78-8060-8010-3	Snap Ring – 42 mm Shaft
6163-21	78-8076-5413-8	Spring
6163-22	78-8076-5414-6	Coupling – Screw, Female
6163-23	78-8076-5415-3	Coupling – Screw, Male
6163-24	26-1003-7946-5	Screw – Soc Hd, M4 x 25
6163-25	78-8076-5416-1	Spacer – Hex, 10 x 107
6163-26	78-8023-2334-1	Screw – Soc Hd, Hex Soc, M6 x 25
6163-27	78-8076-5417-9	Spacer

Rear

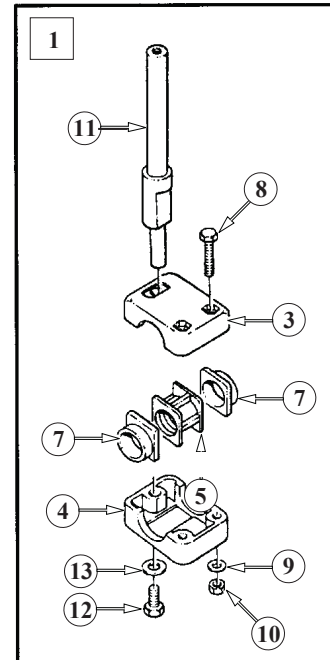
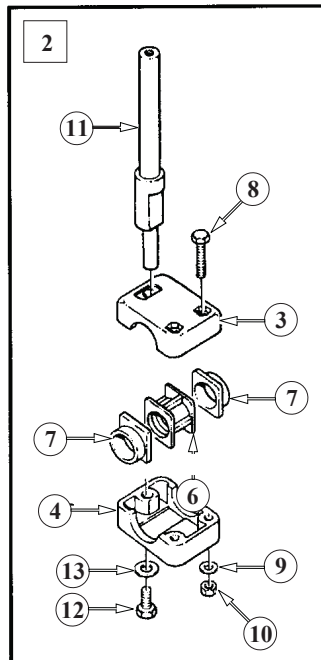
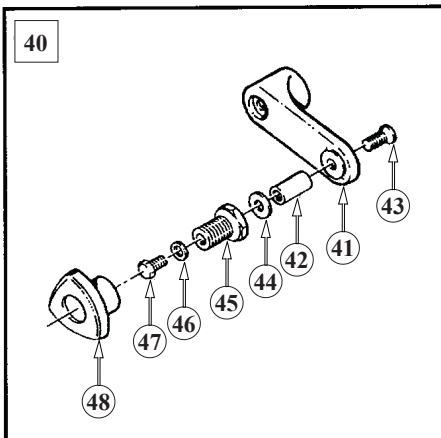
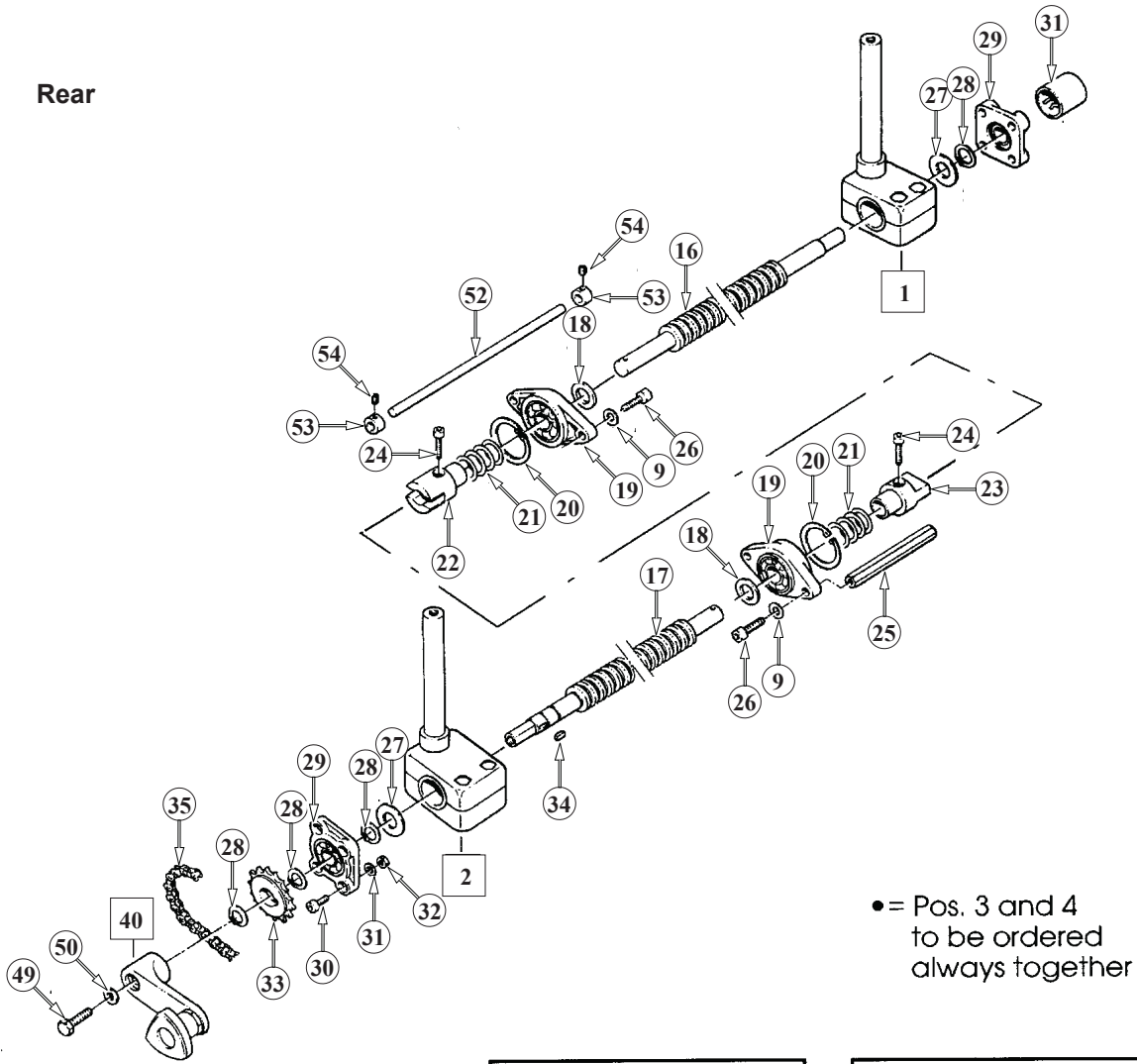

Figure 6163 / 2

800a

Figure 6163 / 2

Ref. No.	3M Part No.	Description
6163-28	78-8017-9079-7	Ring – Snap For 15 mm Shaft
6163-29	78-8076-5418-7	Support – Screw
6163-30	26-1003-7949-9	Screw – Soc Hd Hex Soc, M5 x 12
6163-31	78-8005-5741-1	Washer – Plain M5
6163-32	78-8010-7417-6	Nut – Hex M5
6163-33	78-8076-5419-5	Sprocket – 3/8 Inch Z=16
6163-34	78-8046-8135-7	Key – 5 x 5, 12 mm
6163-35	78-8076-5420-3	Chain – 3/8 Inch, 133 Links
6163-36	78-8076-5421-1	Support – Tension Roller
6163-37	78-8010-7169-3	Screw – Hex Hd, M6 x 12
6163-38	78-8070-1503-3	Roller – Chain Tensioning
6163-39	78-8060-7878-4	Idler Screw
6163-40	78-8076-4807-2	Crank Assembly
6163-41	78-8076-5422-9	Crank
6163-42	78-8070-1509-0	Shaft – Crank
6163-43	26-1005-5316-8	Screw – Flat Hd Hex Dr, M5 x 16
6163-44	78-8070-1510-8	Washer – Nylon, 7 x 15 x 1
6163-45	78-8070-1511-6	Bushing
6163-46	78-8005-5740-3	Washer – Plain 4 mm
6163-47	78-8010-7157-8	Screw – Hex Hd, M4 x 10
6163-48	78-8070-1512-4	Knob – VTR-B-M12
6163-49	78-8032-0375-7	Screw – Hex Hd, M6 x 16
6163-50	78-8076-4809-8	Washer – Crank
6163-51	78-8070-1506-6	Cover – Screw
6163-52	78-8076-5423-7	Shaft
6163-53	78-8076-5424-5	Block
6163-54	78-8076-5425-2	Set Screw – M4 x 3

(*) Not included with Ref. No. 1-2

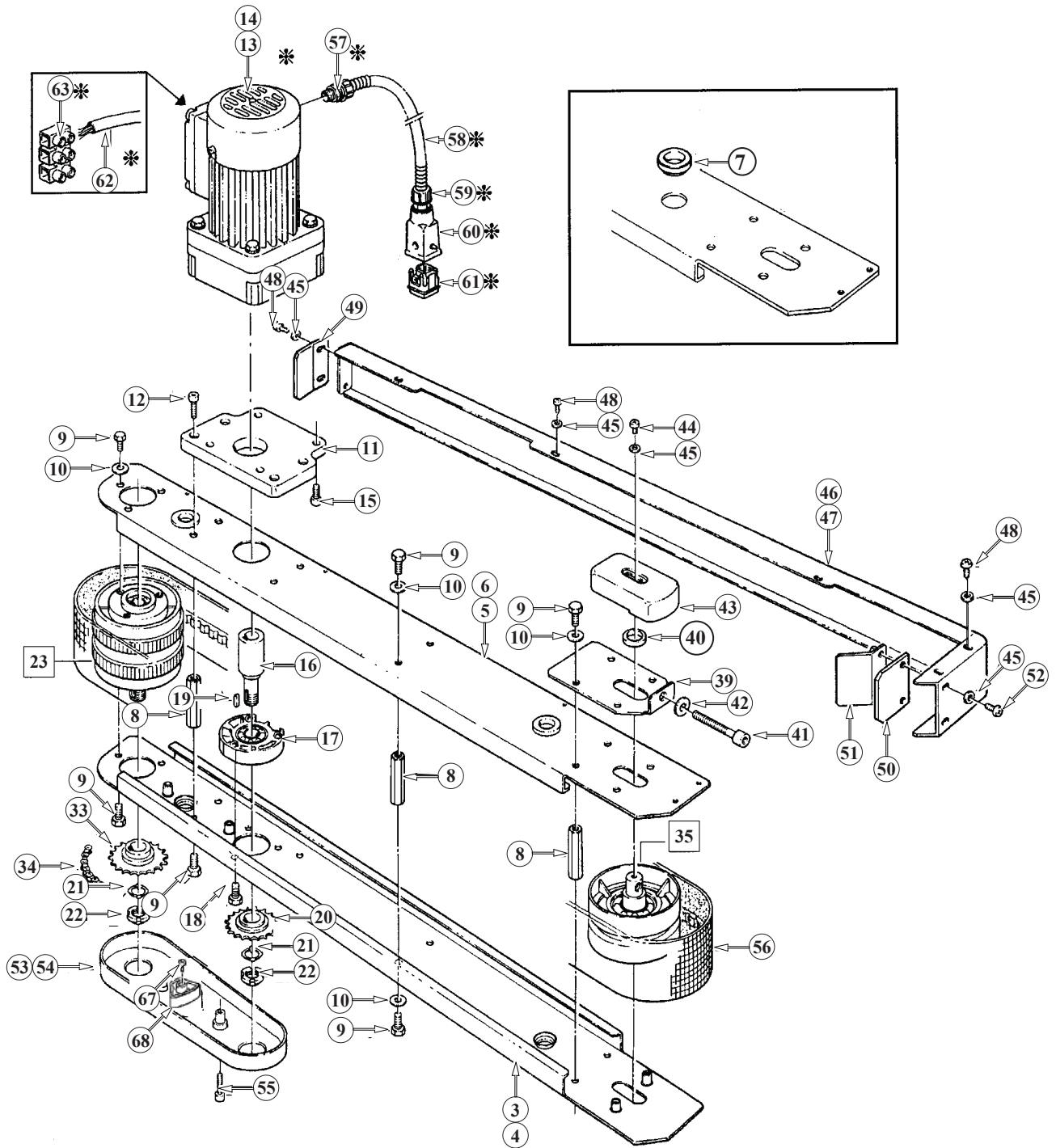

Figure 15230 / 1

Figure 15230 / 1

Ref. No.	3M Part No.	Description
15230-1	78-8100-1205-0	Drive Assembly – R/H W/O Motor
15230-2	78-8100-1206-8	Drive Assembly – L/H W/O Motor
15230-3	78-8100-1207-6	Guide – Lower, R/H
15230-4	78-8100-1208-4	Guide – Lower, L/H
15230-5	78-8113-6818-8	Guide – Upper, R/H, W/English Language Label
15230-6	78-8113-6819-6	Guide – Upper, L/H, W/English Language Label
15230-7	78-8091-0500-6	Bushing – Side Drive
15230-8	78-8055-0661-1	Spacer
15230-9	26-1003-5829-5	Screw – Hex Hd, M6 x 12
15230-10	26-1000-0010-3	Washer – Flat M6
15230-11	78-8094-6109-4	Support – Gearmotor
15230-12	78-8023-2334-1	Screw – Soc Hd, Hex Soc, M6 x 25
15230-13	78-8070-1522-3	Gearmotor – Bodine, 42X5BFCI-E2, 15:1, 115V, 60 Hz
15230-14	26-1011-8828-7	Capacitor – 15 μ F, 300VAC, Motor Run
15230-15	78-8070-1523-1	Screw – 1/4 - 28 x 1/2 SHCS
15230-16	78-8094-6174-8	Extension – Gearmotor
15230-17	78-8076-5439-3	Flange Assembly
15230-18	78-8060-7886-7	Screw – Hex Hd, M6 x 16, Special
15230-19	78-8046-8135-7	Key – 5 x 5, 12 mm
15230-20	78-8137-0934-8	Sprocket – 3/8 Inch, Z-17
15230-21	78-8057-5834-5	Tab Washer
15230-22	78-8057-5835-2	Centering Washer
15230-23	78-8076-5440-1	Pulley Assembly – Drive
15230-24	78-8076-5441-9	Roller – Drive
15230-25	78-8052-6713-1	Ring – Polyurethane
15230-26	78-8055-0669-4	Shaft – Pulley Keyed
15230-27	78-8057-5739-6	Key – M5 x 5 x 30 mm
15230-28	78-8055-0668-6	Washer – 15/26 x 1
15230-29	78-8091-0382-9	Belleville Washer – /16
15230-30	78-8076-5442-7	Flange Assembly
15230-31	26-0001-5862-1	Screw – Flat Hd Soc, M5 x 12
15230-32	78-8054-8877-8	Washer – 5,5/20 x 4
15230-33	78-8137-0935-5	Sprocket 3/8" Z20
15230-34	78-8076-4933-6	Chain – 3/8 Inch Pitch, 52 Pitch

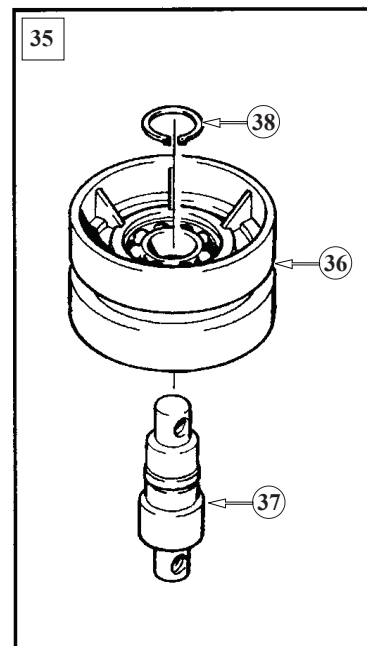
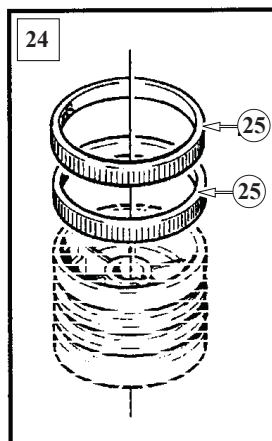
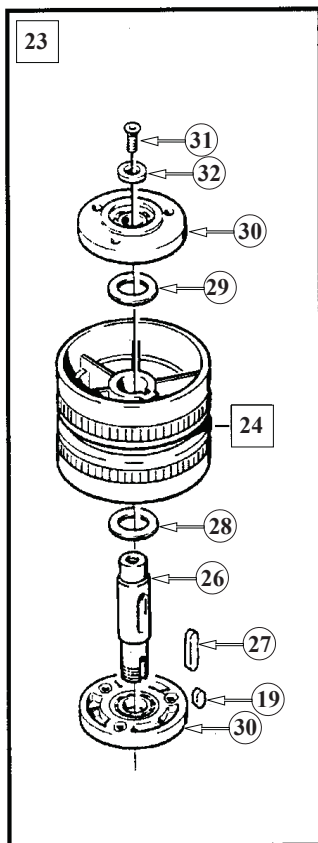
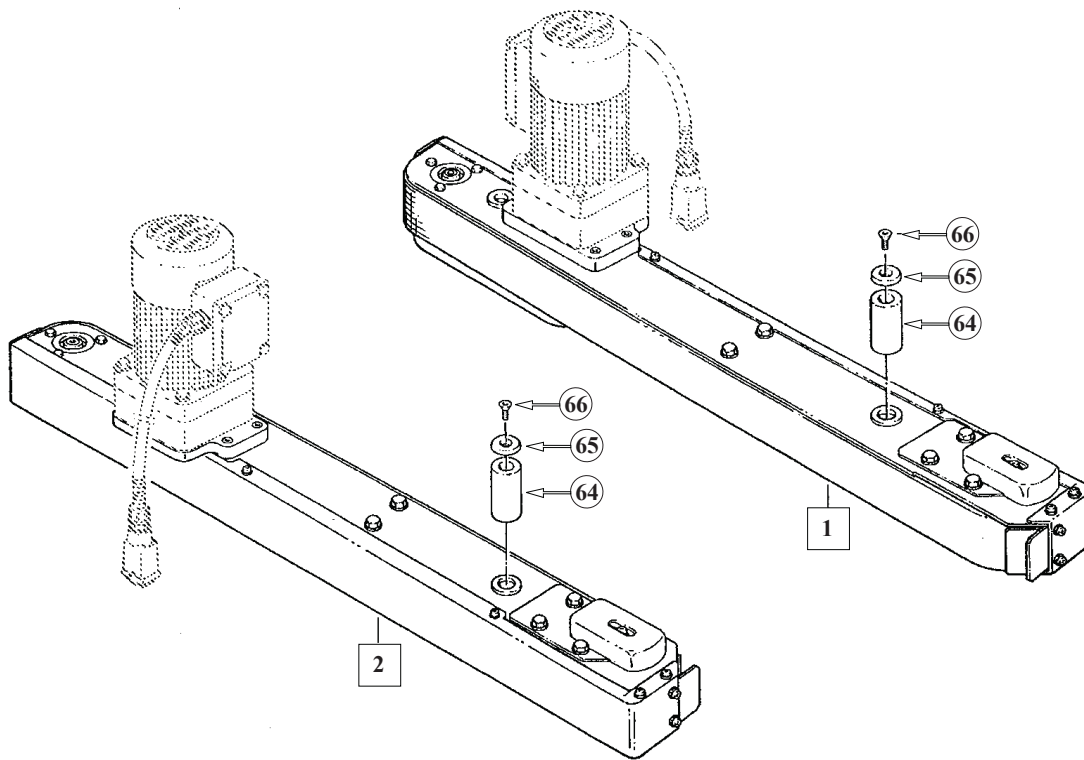

Figure 15230 / 2

800a**Figure 15230 / 2**

Ref. No.	3M Part No.	Description
15230-35	78-8076-5443-5	Pulley Assembly – Idler
15230-36	78-8055-0660-3	Roller – Idler
15230-37	78-8076-5444-3	Shaft – Idler Pulley
15230-38	12-7997-0272-0	E-Ring – M-25
15230-39	78-8076-5445-0	Tensioning – Belt
15230-40	78-8076-5446-8	Washer – Shaft
15230-41	78-8070-1519-9	Screw – Soc Hd, Hex Hd, M8 x 70
15230-42	78-8017-9318-9	Washer – Plain 8 mm
15230-43	78-8076-5448-4	Cover – Belt Tensioner
15230-44	78-8055-0850-0	Screw – Cap, M4 x 6
15230-45	78-8005-5740-3	Washer – Plain 4 mm
15230-46	78-8100-1211-8	Cover – Drive, R/H
15230-47	78-8100-1212-6	Cover – Drive, L/H
15230-48	26-1002-5753-9	Screw – Self-Tapping
15230-49	78-8100-1213-4	Guard – Belt
15230-50	78-8100-1214-2	Guard – Rubber
15230-51	78-8100-1215-9	Guard – Metal
15230-52	78-8076-5255-3	Screw – Phillips Hd, M4 x 12
15230-53	78-8091-0764-8	Cover – Chain, Right
15230-54	78-8091-0765-5	Cover – Chain, Left
15230-55	78-8010-7165-1	Screw – Flat Hd Soc, M5 x 25
15230-56	78-8076-5452-6	Belt – Box Drive
15230-57	78-8060-7631-7	Connector – 3/8 Inch
15230-58	78-8076-5197-7	Sleeving – /12, 800 mm
15230-59	78-8060-7626-7	Connector – PG 11/12
15230-60	78-8060-7877-6	Plug Housing – Vertical
15230-61	78-8060-7875-0	Plug Male
15230-62	78-8060-8053-3	Wire – 3-Pole, 5 Meters Length
15230-63	78-8076-4968-2	Terminal
15230-64	78-8076-5453-4	Roller
15230-65	78-8054-8577-4	Washer – Special
15230-66	26-1001-9843-6	Screw – Flat Soc Hd, M6 x 16
15230-67	78-8010-7210-5	Screw - Tensioner
15230-68	78-8137-0932-2	Tensioner - Pulley R/H
	78-8137-0933-2	Tensioner - Pulley L/H
800a-NA		

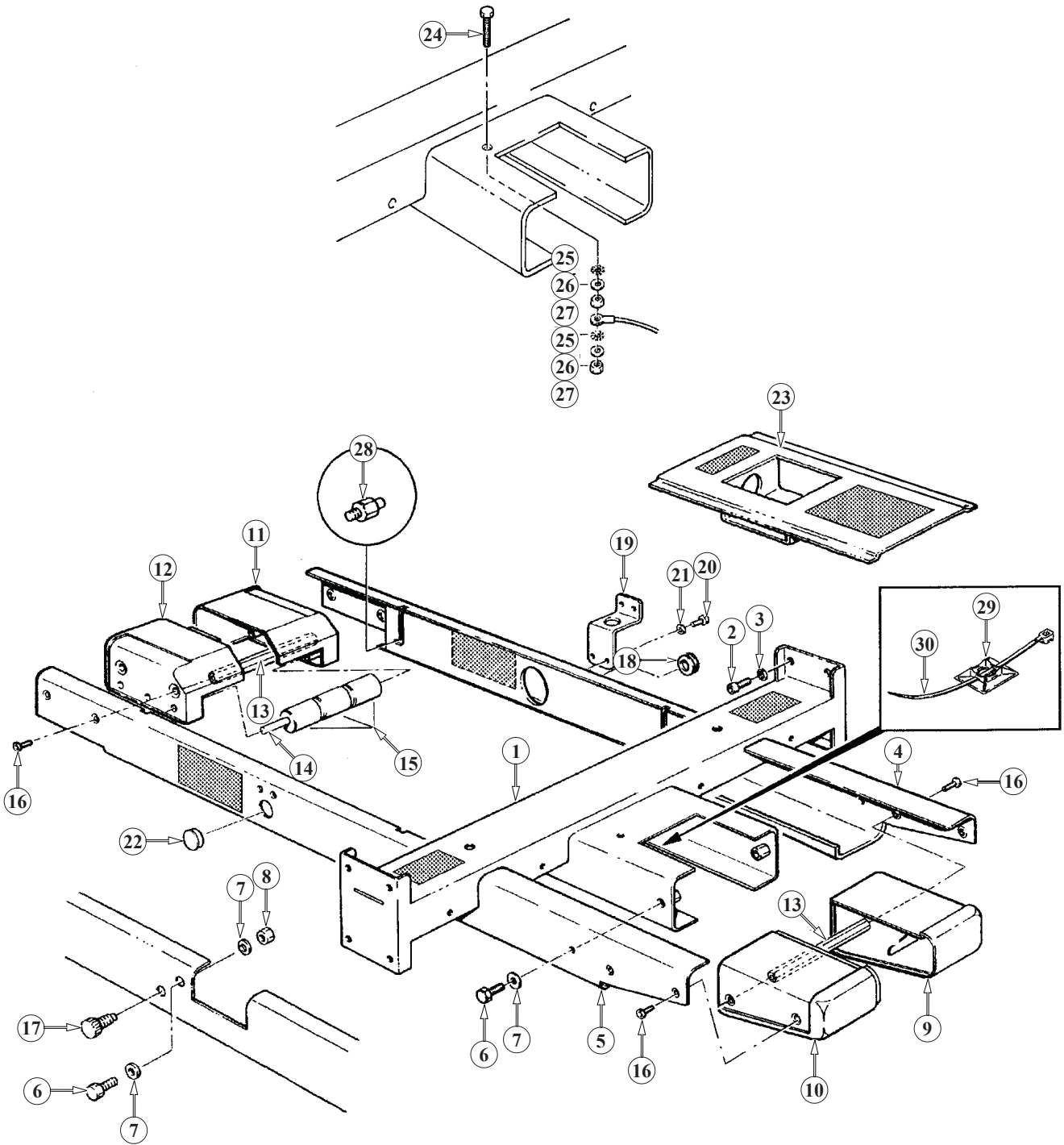

Figure 6165

Figure 6165

Ref. No.	3M Part No.	Description
6165-1	78-8113-6870-9	Cross Bar – Lower, W/English Language Label
6165-2	26-1003-7957-2	Screw – Soc Hd Hex Hd, M6 x 16
6165-3	78-8100-1042-7	Washer – /15 x 6.35 x 2
6165-4	78-8113-6810-5	Frame – R/H, W/English Language Label
6165-5	78-8113-6809-7	Frame – L/H, W/English Language Label
6165-6	26-1003-5842-8	Screw – Hex Hd, M8 x 20
6165-7	78-8017-9318-9	Washer – Plain, 8 mm
6165-8	26-1003-6904-5	Nut – Hex, M8
6165-9	78-8070-1574-4	Slide – Front, Right
6165-10	78-8070-1575-1	Slide – Front, Left
6165-11	78-8070-1576-9	Slide – Rear, Right
6165-12	78-8070-1577-7	Slide – Rear, Left
6165-13	78-8070-1553-8	Spacer
6165-14	78-8070-1554-6	Stud
6165-15	78-8060-7693-7	Roller – 32 x 38
6165-16	26-1005-5316-8	Screw – Flat Hex Hd Dr, M5 x 16
6165-17	78-8070-1555-3	Block – Upper Head
6165-18	78-8060-7758-8	Fairlead – /20
6165-19	78-8054-8955-2	Clamp – Bracket
6165-20	26-1003-5820-4	Screw – Hex Hd, M5 x 12
6165-21	78-8005-5741-1	Washer – Flat, M5
6165-22	78-8076-4517-7	End Cap – /22 x 1
6165-23	78-8113-6758-6	Cover – Upper, W/English Language Label
6165-24	78-8091-0538-6	Screw – Hex Hd, M4 x 20
6165-25	78-8076-4716-5	Star Washer – M4
6165-26	78-8005-5740-3	Washer – Plain, 4 mm
6165-27	78-8010-7416-8	Nut – Hex, M4
6165-28	78-8076-4991-4	Spacer
6165-29	78-8100-1240-7	Plate
6165-30	78-8060-8029-3	Clamp – 140X3,5

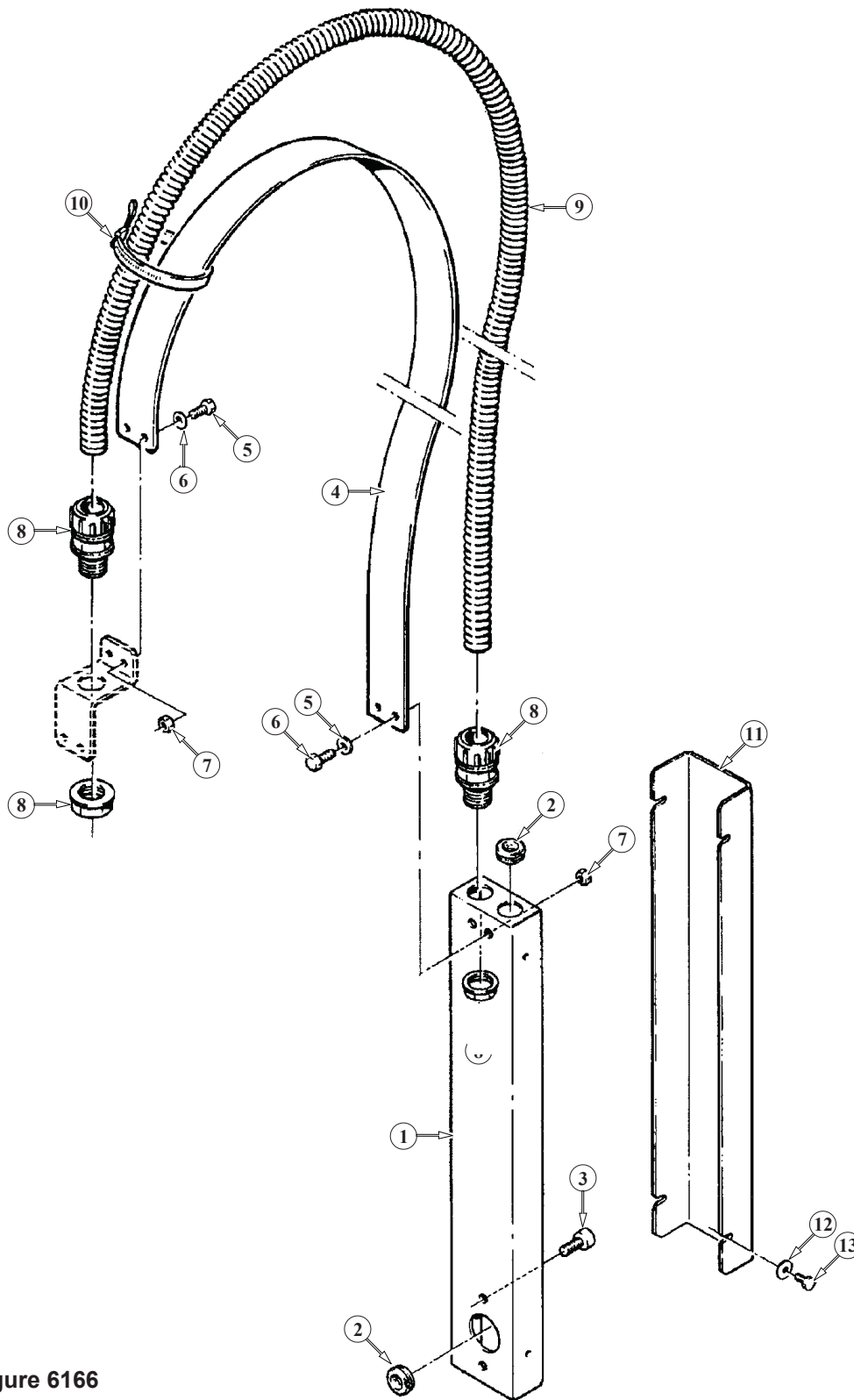

Figure 6166

800a

Figure 6166

Ref. No.	3M Part No.	Description
6166-1	78-8100-1218-3	Housing – Wire
6166-2	78-8060-7758-8	Fairlead – /20
6166-3	26-1003-7963-0	Screw – Soc Hd, M8 x 16
6166-4	78-8076-4636-5	Strap – Wire
6166-5	78-8010-7163-6	Screw – Hex Hd, M5 x 10
6166-6	78-8005-5741-1	Washer – Flat, M5
6166-7	78-8010-7417-6	Nut – Hex, M5
6166-8	78-8060-7631-7	Connector – 3/8 Inch
6166-9	78-8060-8154-9	Sleeving – 0,90 MT
6166-10	78-8060-8029-3	Clamp – 140 x 3,5
6166-11	78-8100-1219-1	Cover – Housing
6166-12	78-8017-9018-5	Washer – Plain, M4
6166-13	78-8010-7157-8	Screw – Hex Hd, M4 x 10

THIS PAGE IS BLANK



Instructions and Parts List

3M-MaticTM

AccuglideTM **3**

Upper and

Lower

High Speed

Taping Heads

2 Inch

Type 10800

Serial No. _____

For reference, record taping head(s) serial number(s) here.



3M Industrial Adhesives and Tapes

3M Center, Building 220-5E-06
St. Paul, MN 55144-1000



Important Safety Information

BEFORE INSTALLING
OR OPERATING THIS
EQUIPMENT

Read, understand, and
follow all safety and
operating instructions.

Spare Parts

It is recommended you
immediately order the
spare parts listed in the
"Spare Parts/Service
Information" section.

These parts are expected
to wear through normal
use, and should be kept
on hand to minimize
production delays.

AccuGlide™ is a Trademark of
3M, St. Paul, MN 55144-1000
Printed in U.S.A.

© 3M 2012 44-0009-2070-0 (E010712-NA)

Replacement Parts and Service Information

To Our Customers:

This is the 3M-Matic™/AccuGlide™/Scotch® equipment you ordered. It has been set up and tested in the factory with Scotch® tapes. If technical assistance or replacement parts are needed, call or fax the appropriate number listed below.

Included with each machine is an Instructions and Parts List manual.

Technical Assistance / Replacement Parts and Additional Manuals:

Call the 3M-Matic™ Help line at 1-800 328-1390. Provide the customer support coordinator with the model/machine name, machine type, and serial number that are located on the identification plate (For example: Model 200a - Accuglide 3 - 2 inch - Type 10800 - Serial Number 13282).

United States -

3M Tape Dispenser Parts

241 Venture Drive

1-800-344-9883

Amery, WI 54001-1325

Fax: 1-715-268-8153

Identification Plate

3M 3M Company St. Paul, MN 55144 USA	Part Number <input type="text"/>	3M-Matic™	 4000563	
Model <input type="text"/>	Serial Number <input type="text"/>	Year <input type="text"/>	Ampere <input type="text"/>	Watt <input type="text"/>
Type <input type="text"/>		Volt <input type="text"/>	Hertz <input type="text"/>	Phase <input type="text"/>

Minimum billing on parts orders will be \$25.00. Replacement part prices available on request.
\$10.00 restocking charge per invoice on returned parts

Note : Outside the U.S., contact the local 3M subsidiary for parts ordering information.



3M Industrial Adhesives and Tapes

3M Center, Building 220-5E-06
St. Paul, MN 55144-1000

3M-Matic™, AccuGlide™ and Scotch™
are Trademarks of
3M St. Paul, MN 55144-1000
Printed in U.S.A.

THIS PAGE IS BLANK

Replacement Parts And Service Information

To Our Customers:

This is the 3M-Matic™/AccuGlide™/Scotch® equipment you ordered. It has been set up and tested in the factory with Scotch® tapes. If any problems occur when operating this equipment and you desire a service call or phone consultation, call, write, or fax the appropriate number listed below.

Included with each machine is an Instructions and Parts List manual.

SERVICE, REPLACEMENT PARTS, AND ADDITIONAL MANUALS

AVAILABLE DIRECT FROM:

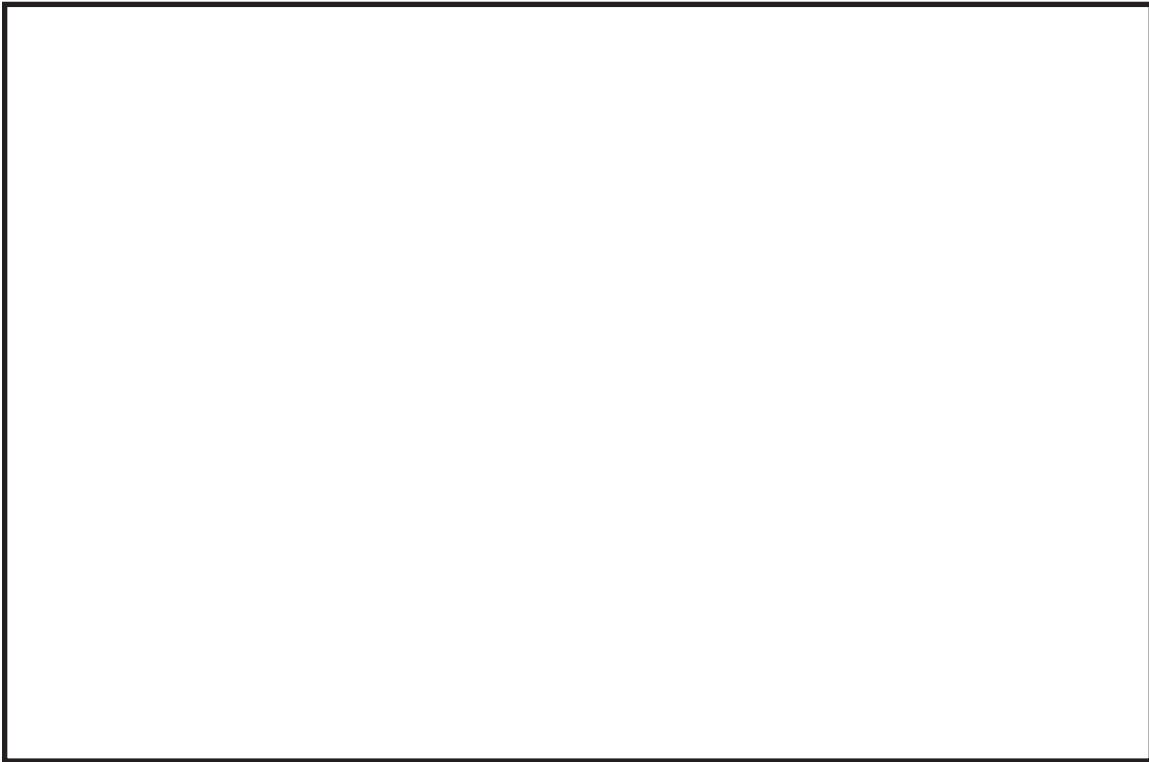

Order parts by part number, part description, and quantity required. Also, when ordering parts or additional manuals, include model/machine name, machine type, and serial number that are located on the identification plate.



3M Industrial Adhesives and Tapes

3M Center, Building 220-5E-06
St. Paul, MN 55144-1000

3M-Matic™, AccuGlide™ and Scotch™
are Trademarks of
3M, St. Paul, MN 55144-1000
Printed in U.S.A.

THIS PAGE IS BLANK

Instruction Manual

AccuGlide™ 3 High Speed 2 Inch Upper and Lower Taping Heads Type 10800

Table of Contents	Page
Replacement Parts and Service Information	i - ii
Table of Contents.....	iii
Equipment Warranty and Limited Remedy.....	iv
Intended Use	1
Taping Head Contents / How to Use Manual.....	3
Important Safeguards.....	4 - 5
Specifications	6 - 7
Dimensional Drawing	7
Installation	8
Receiving and Handling	8
Installation Guidelines.....	8
Tape Leg Length	8
Tape Width Adjustment	8
Operation.....	9 - 11
Tape Loading – Upper Taping Head.....	10
Tape Loading – Lower Taping Head.....	10 - 11
Maintenance	12 - 13
Blade Replacement.....	12
Blade Guard	12
Blade Oiler Pad	12
Cleaning.....	13
Applying/Buffering Roller Replacement.....	13
Adjustments.....	14 - 16
Tape Latch Alignment.....	14
Tape Drum Friction Brake	14
Applying Mechanism Spring.....	15
One-Way Tension Roller	15
Tape Leg Length	16
Leading Tape Leg Length Adjustment	16
Changing Tape Leg Length From 70 to 50 mm [2-3/4 to 2 Inch]	16
Troubleshooting Guide	17 - 18
Spare Parts/Service Information.....	19
Recommended Spare Parts.....	19
Replacement Parts and Service.....	19
Replacement Parts Illustrations and Parts List.....	Yellow Section 20 - 37

Warranty

Equipment Warranty and Limited Remedy:

Equipment Warranty and Limited Remedy: THE FOLLOWING WARRANTY IS MADE IN LIEU OF ALL OTHER WARRANTIES, EXPRESS OR IMPLIED, INCLUDING, BUT NOT LIMITED TO, ANY IMPLIED WARRANTY OF MERCHANTABILITY OR FITNESS FOR A PARTICULAR PURPOSE AND ANY IMPLIED WARRANTY ARISING OUT OF A COURSE OF DEALING, CUSTOM OR USAGE OF TRADE:

3M sells its **AccuGlide™ 3 High Speed 2 Inch Upper and Lower Taping Heads, Type 10800** with the following warranty:

1. The Taping Head blade, springs and rollers will be free from defects in material and manufacture for ninety (90) days after delivery.
2. All other Taping Head parts will be free from defects in material and manufacture for three (3) years after delivery.

If any part is defective within this warranty period, your exclusive remedy and 3M's and seller's sole obligation shall be, at 3M's option, to repair or replace the part. 3M must receive actual notice of any alleged defect within a reasonable time after it is discovered, but in no event shall 3M have any obligation under this warranty unless it receives such notice within five (5) business days after the expiration of the warranty period. All notices required hereunder shall be given to 3M solely through the 3M-Matic™ Help line (800-328-1390). To be entitled to repair or replacement as provided under this warranty, the part must be returned as directed by 3M to its factory or other authorized service station designated by 3M. If 3M is unable to repair or replace the part within a reasonable time after receipt thereof, 3M, at its option, will replace the equipment or refund the purchase price. 3M shall have no obligation to provide or pay for the labor required to remove any part or equipment or to install the repaired or replacement part or equipment. 3M shall have no obligation to repair or replace those parts failing due to normal wear, inadequate or improper maintenance, inadequate cleaning, non-lubrication, improper operating environment, improper utilities, operator error or misuse, alteration or modification, mishandling, lack of reasonable care, or due to any accidental cause.

Limitation of Liability: Except where prohibited by law, 3M and seller will not be liable for any loss or damage arising from this 3M equipment, whether direct, indirect, special, incidental, or consequential, regardless of the legal theory asserted, including breach of warranty, breach of contract, negligence, or strict liability.

Note: The foregoing Equipment Warranty and Limited Remedy and Limitation of Liability may be changed only by a written agreement signed by authorized representatives of 3M and seller.

AccuGlide™, Scotch™, and 3M-Matic™ are Trademarks of 3M, St. Paul, Minnesota 55144-1000

Intended Use

The intended use of the AccuGlide™ 3 Upper and Lower Taping Heads - 2 Inch is to apply a "C" clip of Scotch® pressure-sensitive film box sealing tape to the top and/or bottom center seam of regular slotted containers.

These taping heads are incorporated into most standard 3M-Matic™ case sealers. The compact

size and simplicity of the taping head also makes it suitable for mounting in box conveying systems other than 3M-Matic™ case sealers. This includes replacement of other types of taping, gluing or stapling heads in existing case sealing machines. The AccuGlide™ 3 Upper and Lower Taping Heads - 2 Inch have been designed and tested for use with Scotch® pressure-sensitive film box sealing tape.

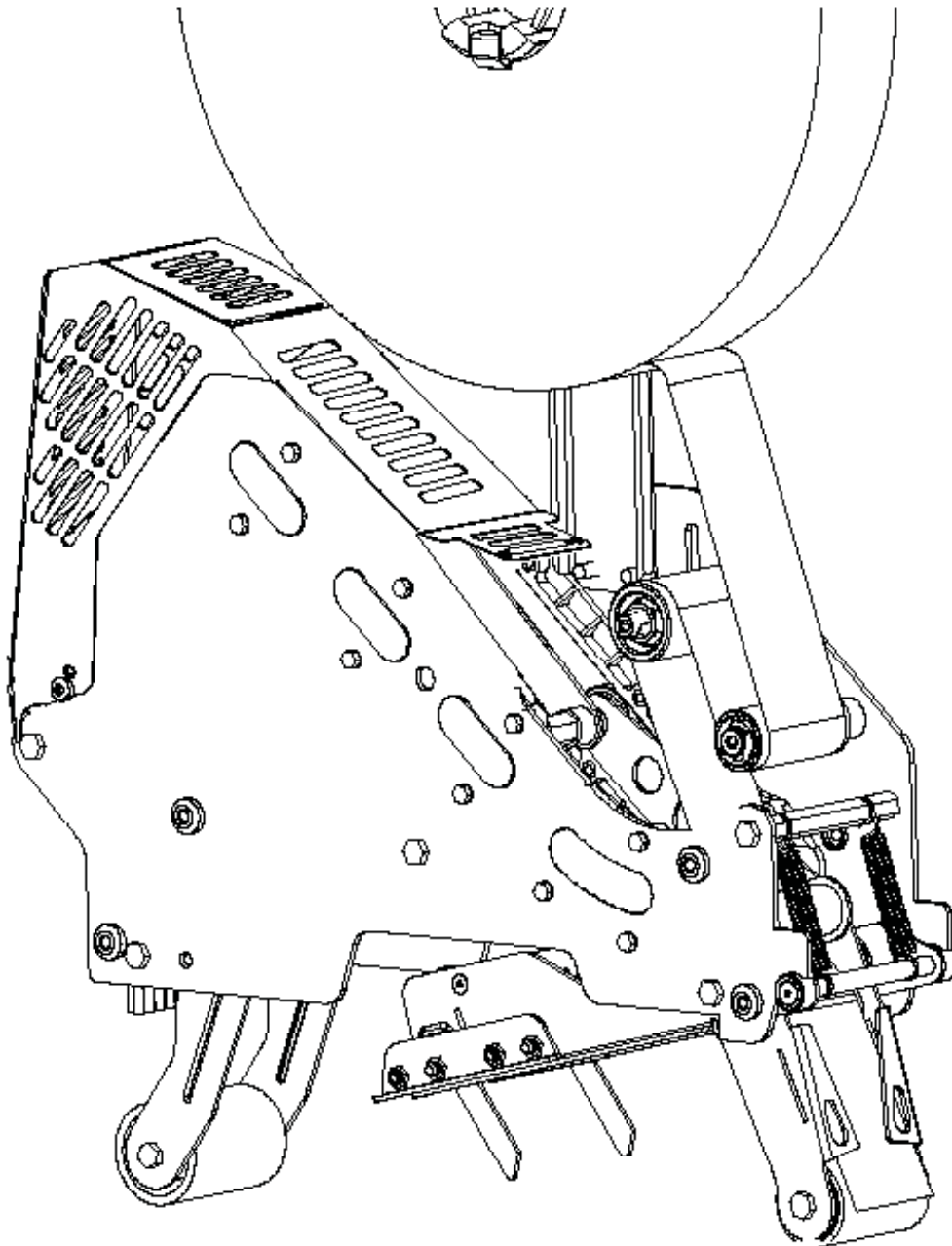

AccuGlide™ 3 Upper Taping Head - 2 inch, Type 10800

THIS PAGE IS BLANK

Taping Head Contents

AccuGlide™ 3 High Speed 2 Inch Upper and Lower Taping Heads consist of:

Qty.	Part Name
1	Taping Head Assembly
1	Tape Drum and Bracket Assembly
1	Hardware and Spare Parts Kit
1	Threading Tool

General Information

This instruction manual covers safety aspects, handling and transport, storage, unpacking, preparation, installation, operation, set-up and adjustments, technical and manufacturing specifications, maintenance, troubleshooting, repair work and servicing, electric diagrams, warranty information, disposal (ELV), a glossary with a definition of symbols, plus a parts list of the 3M-Matic™ Accuglide 3 (2 inch) 3M Industrial Adhesives and Tapes Division 3M Center, Bldg. 220-5E-06 St. Paul, MN 55144-1000 (USA) Edition January 2012/Copyright 3M 2012. All rights reserved The manufacturer reserves the right to change the product at any time without notice.

How to use this Manual

The manual is an important part of the machine; all information contained herein is intended to enable the equipment to be maintained in perfect condition and operated safely. Ensure that the manual is available to all operators of this equipment and the manual is kept up to date with all subsequent amendments. Should the equipment be sold or disposed of, please ensure that the manual is passed on with the machine.

Electrical and pneumatic diagrams are included in the manual. Equipment using PLC controls and/or electronic components will include relevant schematics or programs in the enclosure (or will be delivered separately as needed)

Keep the manual in a clean and dry place near the machine. Do not remove, tear or rewrite parts of the manual for any reason. Use the manual without damaging it. However, if the manual has been lost or damaged, ask your after sale service for a new copy (if it is possible, please have the manual name, part number, and revision information and/or model/machine name, machine type, and serial number) that are located on the identification plate **(For example: Model 200a - Accuglide 3 - 2" - Type 10800 - Serial Number 13282).**

Note:

All the important warning notes related to the operation of the machine are identified by the symbol:



Updating the Manual

Modifications to the machine are subject to manufacturer's internal procedures. The user may receive pages or parts of the manual which contain amendment made after its first publication. The user must use them to update this manual.

Important Safeguards



This safety alert symbol identifies important safety messages in this manual. **READ AND UNDERSTAND THEM BEFORE INSTALLING OR OPERATING THIS EQUIPMENT.**

Explanation of Signal Word Consequences



CAUTION: Indicates a potentially hazardous situation, which, if not avoided, may result in minor or moderate injury and/or property damage.



WARNING: Indicates a potentially hazardous situation, which, if not avoided, could result in death or serious injury and/or property damage.



WARNING

- **To reduce the risk associated with mechanical hazards:**
 - Read, understand and follow all safety and operating instructions before operating or servicing the case sealer
 - Allow only properly trained and qualified personnel to operate and/or service this equipment
- **To reduce the risk associated with shear, pinch, and entanglement hazards:**
 - Turn air and electrical supplies off on associated equipment before performing any adjustments, maintenance, or servicing the taping heads
 - Never attempt to work on the taping head or load tape while the box drive system is running
- **To reduce the risk associated with sharp blade hazards:**
 - Keep hands and fingers away from tape cutoff blades under orange blade guards. The blades are extremely sharp.



CAUTION

- **To reduce the risk associated with muscle strain:**
 - Use proper body mechanics when removing or installing taping heads that are moderately heavy or may be considered awkward to lift
- **To reduce the risk associated with impact hazards:**
 - Place the taping head on a smooth level surface when maintaining or servicing this equipment

(Important Safeguards continued on next page)

Important Safeguards (continued)

Important - In the event the following safety labels are damaged or destroyed, they must be replaced to ensure operator safety. See "Replacement Parts Illustrations and Parts Lists" for label part numbers.

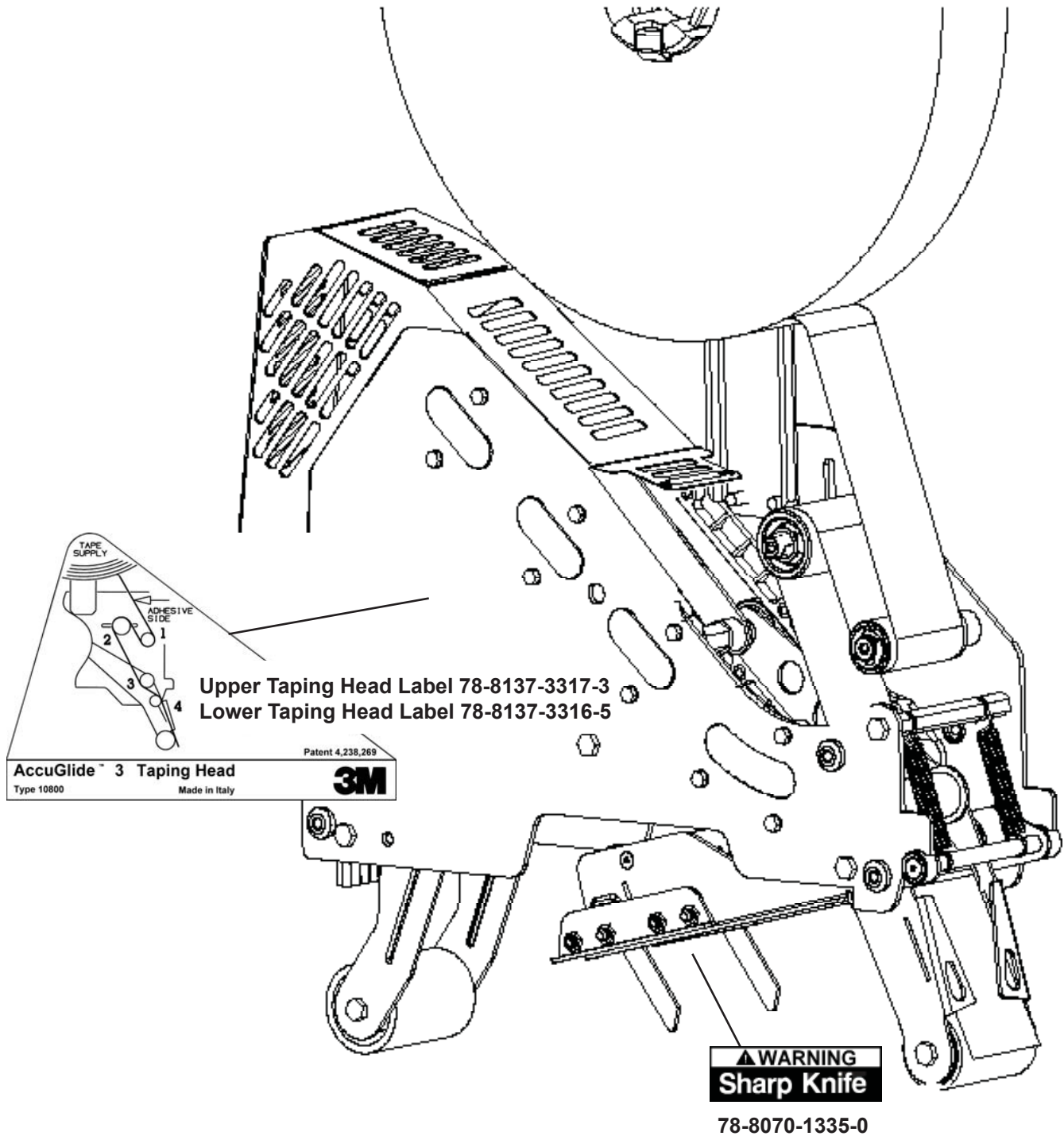

Figure 1-1 Replacement Labels/3M Part Numbers

Specifications

1. **Tape:**

For use with Scotch® pressure-sensitive film box sealing tapes.

2. **Tape Width:**

36mm or 1-1/2 inches minimum to 48mm [2 inches] maximum.

3. **Tape Roll Diameter:**

Up to 405mm [16 inches] maximum on a 76.2mm [3 inch] diameter core.
(Accommodates all system roll lengths of Scotch® film tapes.)

4. **Tape Application Leg Length - Standard:**

70mm ± 6mm [2-3/4 inches ± 1/4 inch]

Tape Application Leg Length - Optional:

50mm ± 6mm [2 inches ± 1/4 inch] (See "Adjustments – Tape Leg Length.")

5. **Box Size Capacities:**

For use with center seam regular slotted containers.

Length – 443mm [17.44 inches] w/ Guard

Height – 406mm [16 inches] w/ Guard

Width – 107mm [4.2 inches]

When upper and lower taping heads are used on “**3M-Matic**” case sealers, refer to the respective instruction manual specifications for box weight and size capacities.

6. **Operating Rate:**

Conveyor speeds up to 0.5 m/s [100 feet per minute].

7. **Operating Conditions:**

Use in dry, relatively clean environments at 5° to 40°C [40° to 105°F] with clean dry boxes.

Important – Taping heads should not be washed down or subjected to conditions causing moisture condensation on components.

8. **Taping Head Dimensions:**

Length	–	442mm [17 3/8 inches]
Height	–	648mm [25 1/2 inches] (with tape drum)
Width	–	105mm [4-1/8 inches] (without mounting spacers)
Weight	–	Packaged: 8.6kg [19 lbs.] Unpackaged: 7.7kg [17 lbs.]

(Specifications continued on next page.)

Specifications

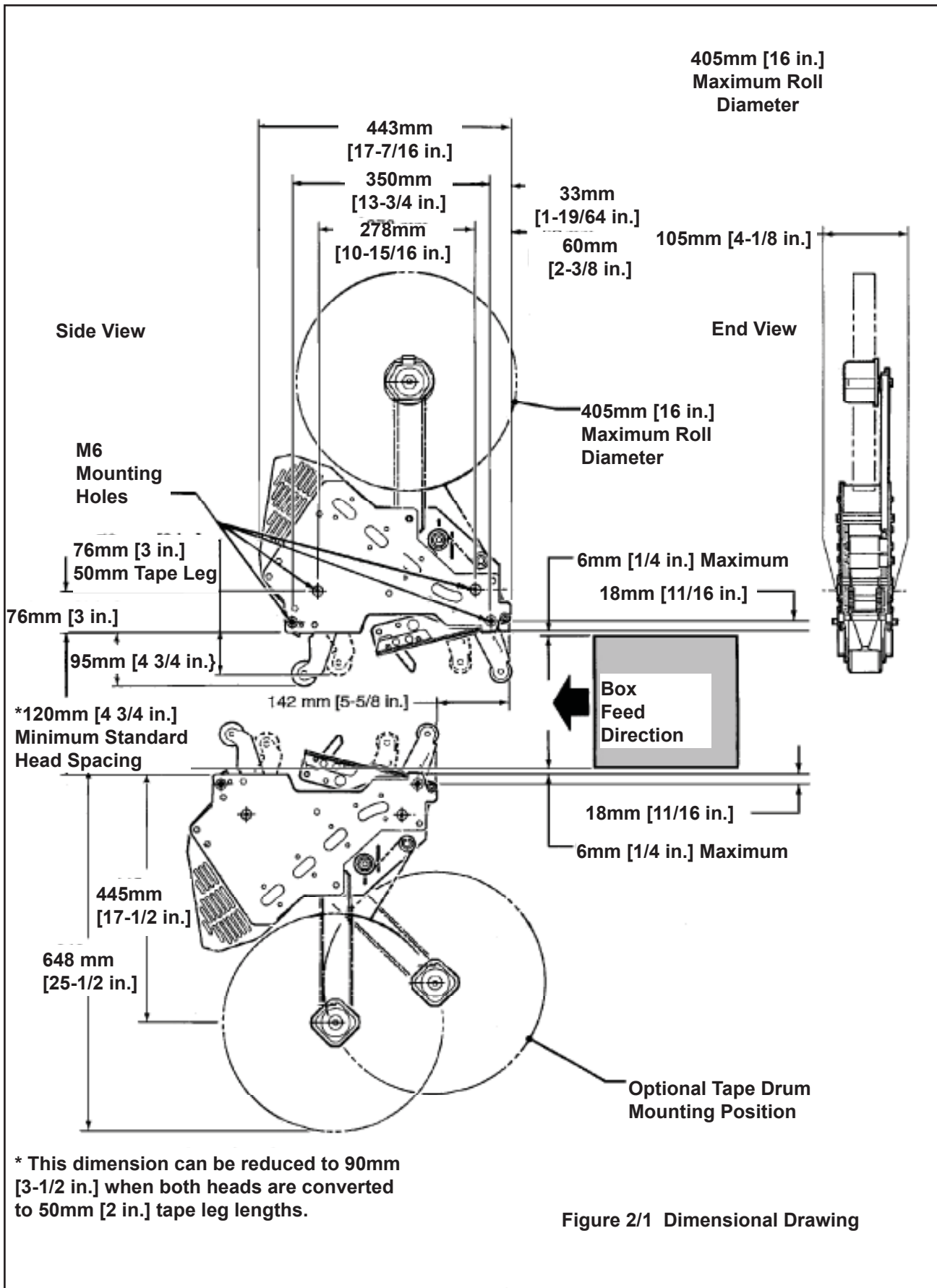

Figure 2/1 Dimensional Drawing

Installation



WARNING

- **To reduce the risk associated with sharp blade hazards:**
 - Keep hands and fingers away from tape cutoff blades under orange blade guards.
The blades are extremely sharp

Receiving And Handling

After the taping head assembly has been unpackaged, examine the unit for damage that might have occurred during transit. If damage is evident, file a damage claim immediately with the transportation company and also notify your 3M Representative.

Installation Guidelines

The taping head assembly can be used in converting existing or in custom made machinery. It can be mounted for top taping or bottom taping. Refer to "Box Size Capacities," as well as **Figure 2-1** in the Specifications section, for the following points in making such installations:



CAUTION

- **To reduce risk associated with muscle strain:**
 - Use proper body mechanics when removing or installing taping heads that are moderately heavy or may be considered awkward to lift

Important – Always conduct a hazard review to determine appropriate guarding requirements when the installation is in an application other than 3M-Matic™ equipment

1. The box conveying system must positively propel the box in a continuous motion, not exceeding 0.40 m/s [80 feet per minute], past the taping head assembly since the box motion actuates the taping mechanism.
2. If a pusher or cleated conveyor is being used, steps should be taken in the conveyor design to prevent the pusher from contacting the applying or buffing roller arms resulting in damage to the taping head.

3. **Figure 2-1** illustrates the typical mounting relationship for opposing taping head assemblies to allow taping of box heights down to 90mm [3-1/2 inches]. To tape box heights down to 70mm [2-3/4 inches], the taping heads must be completely staggered so only one tape seal is being applied at one time.

Note—AccuGlide™ 3 High Speed Upper Taping Head is supplied with a buffing arm guard. Adjustments to this guard may be required to install the taping head into some older design 3M-Matic™ case sealers.

4. Mounting studs are provided with the taping head, but special installations may require alternate means for mounting.
5. Box hold-down or guide skis should be provided and the taping head mounted so that the side plates are 6mm [1/4 inch] maximum away from the ski surface on which the box rides.

Tape Leg Length

Taping heads are factory set to apply standard 70mm [2-3/4 inch] tape legs. The heads can be converted to apply 50mm [2 inch] tape legs if desired but both upper and lower heads must be set to apply the same tape leg length. See "Adjustments – Changing Tape Leg Length From 70 to 50mm [2-3/4 to 2 Inches]."

Also, the conveyor speed at which the product moves through the taping heads, affects the leading and trailing tape leg length. See "Adjustments section – Leading Tape Leg Length Adjustment."

Tape Width Adjustment

Taping heads are factory set to apply 48mm [2 inch] wide tape. If it is necessary to align the tape or to apply narrower tapes, refer to "Adjustments – Tape Web Alignment" for set-up procedure.

Operation

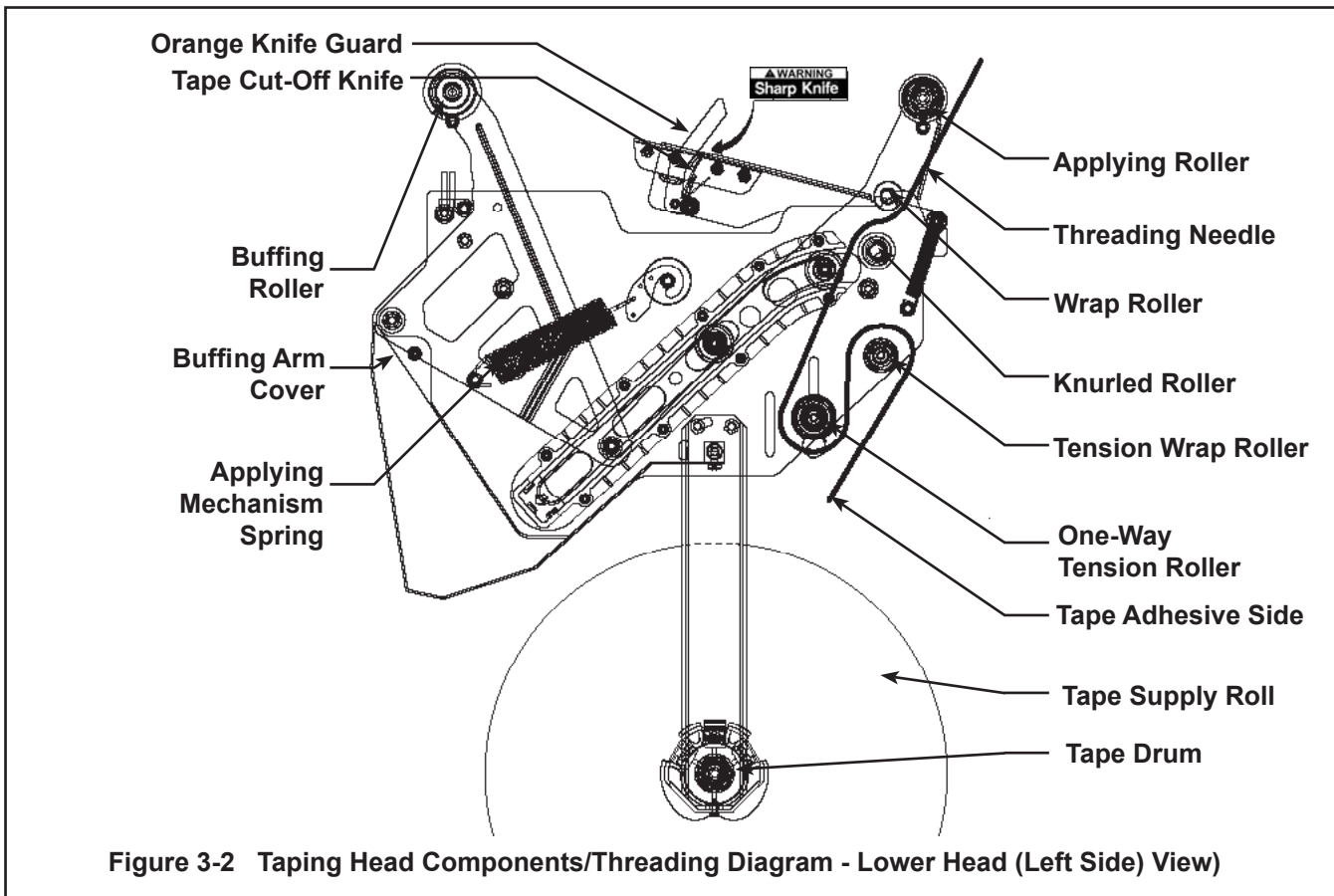
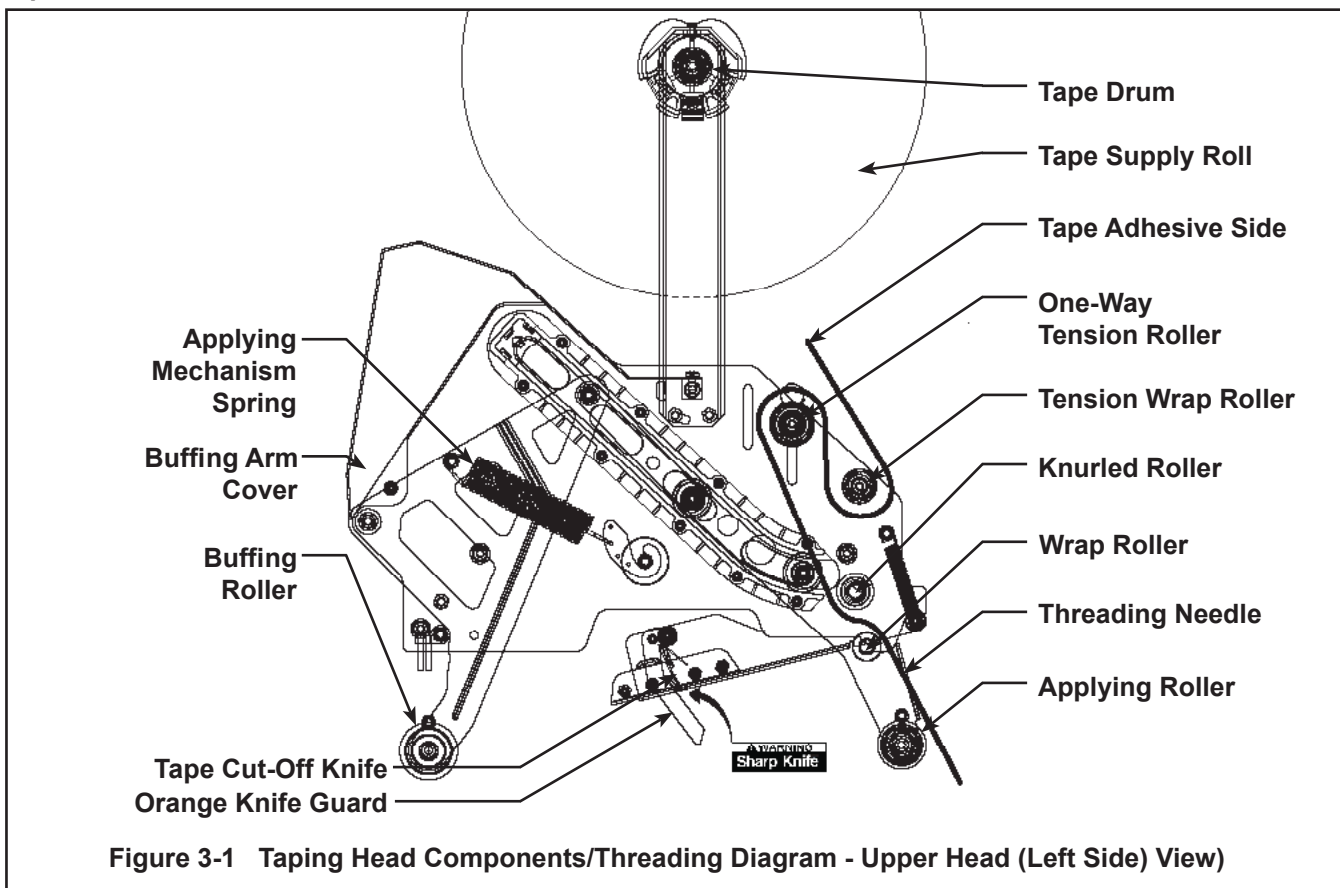



WARNING

- **To reduce the risk associated with shear, pinch, and entanglement hazards:**
 - Turn air and electrical supplies off on associated equipment before performing any adjustments, maintenance, or servicing the machine or taping heads
 - Never attempt to work on the taping heads or load tape when the box drive system is running
- **To reduce the risk associated with sharp blade hazards:**
 - Keep hands and fingers away from tape cutoff blades under orange blade guards.
The blades are extremely sharp

It is recommended that the detailed instructions and sketches in this manual be referred to the first few times the taping head is loaded/threaded until the operator becomes thoroughly familiar with the tape loading operation.

Note – Remove tape roll before removing taping head from machine to minimize weight.



CAUTION

- **To reduce the risk associated with muscle strain:**
 - Use proper body mechanics when removing or installing taping heads that are moderately heavy or may be considered awkward to lift
- **To reduce the risk associated with impact hazards:**
 - Place the taping head on a smooth level surface when maintaining or servicing this equipment

Tape Loading – Upper Taping Head

1. Place the upper taping head in a convenient working position.
2. Use **Figures 3-3 to 3-5** and tape threading label. Position the tape supply roll so the adhesive side of tape is facing the front of the taping head as it is pulled from the supply roll.
3. Attach the threading needle to the end of the roll. Guide the threading needle around the wrap roller (Position 1) then back around the one-way tension roller (Position 2).
4. Continue pulling the threading needle down and guide it between the two rollers on the apply arm (Position 3).

5. Pull the threading needle down until the tape travels between the apply plate and the ears of the apply arm (Position 4) until it extends past the applying roller. When properly threaded the adhesive side of the tape should be facing the knurled rollers at position 2 and also position 3.
6. Cut away any excess tape.

Important – Do not cut against the apply roller - roller damage could occur.

Tape Loading – Lower Taping Head

1. Remove the lower taping head from the conveyor bed or associated equipment and place it a convenient working position.
2. The lower taping head is loaded and threaded in the same manner as the upper head. Follow the upper taping head tape loading/threading procedure.

Figure 3-3

Insert threading needle through rollers in direction indicated by arrows.

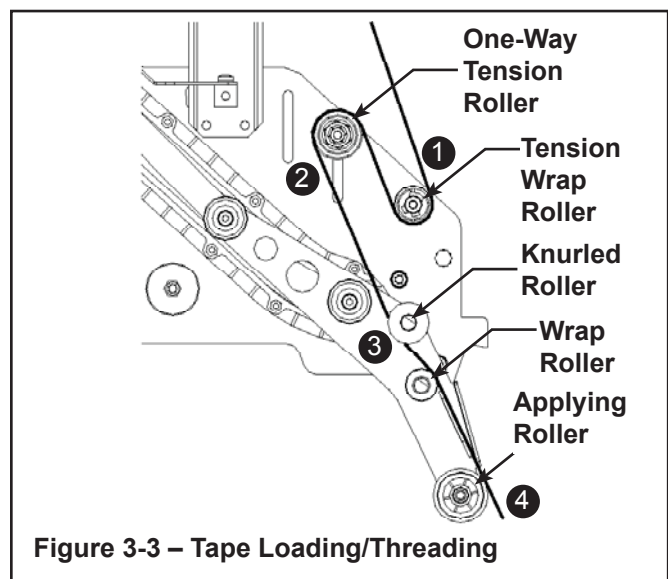

Figure 3-3 – Tape Loading/Threading

Figure 3-4

Place tape roll on tape drum to dispense tape with adhesive side forward. Seat tape roll fully against back flange of drum. Adhere tape lead end to threading needle as shown.

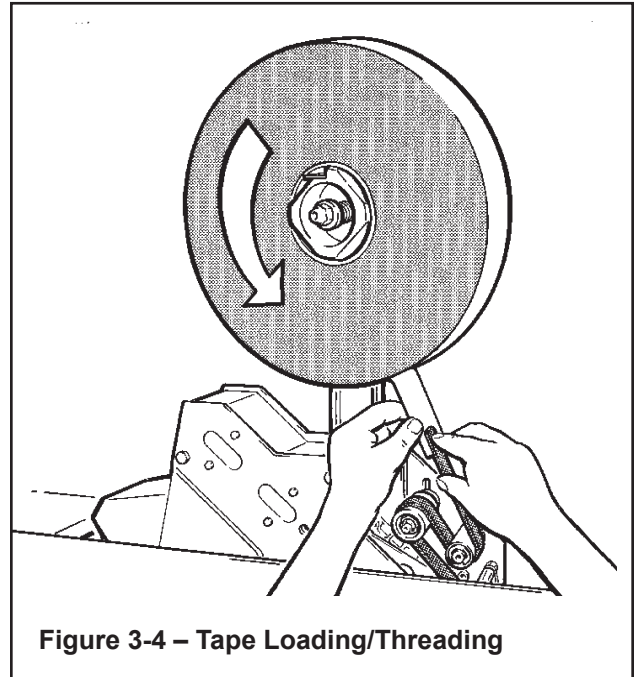

Figure 3-4 – Tape Loading/Threading



WARNING

- **To reduce the risk associated with sharp blade hazards:**
 - Keep hands and fingers away from tape cutoff blades under orange blade guards. The blades are extremely sharp.

Manually turn tape roll to create slack tape while pulling threading needle through tape applying mechanism until needle is through and tape is in alignment with applying roller.

Excess tape can be cut with a scissors at applying roller.

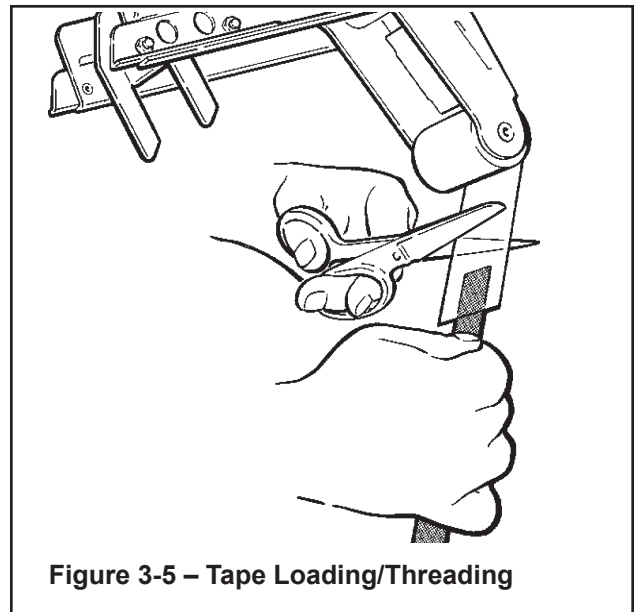

Figure 3-5 – Tape Loading/Threading



WARNING

- **To reduce the risk associated with shear, pinch, and entanglement hazards:**
 - Turn air and electrical supplies off on associated equipment before performing any adjustments, maintenance, or servicing the taping heads
 - Never attempt to work on the taping head or load tape while the box drive system is running
- **To reduce the risk associated with sharp blade hazards:**
 - Keep hands and fingers away from tape cutoff blades under orange blade guards. The blades are extremely sharp

The AccuGlide™ 3 High Speed 2 Inch Taping Head has been designed for long, trouble free service. The taping head will perform best when it receives routine maintenance and cleaning. Taping head components that fail or wear excessively should be promptly repaired or replaced to prevent damage to other portions of the head or to the product.

Blade Replacement, Upper and Lower Taping Heads – Figure 4-1



WARNING

- **To reduce the risk associated with sharp blade hazards:**
 - Keep hands and fingers away from tape cutoff blades under orange blade guards. The blades are extremely sharp.

1. Loosen, but do not remove, the blade screws (A). Remove and discard old blade.
2. Mount the new blade (B) with the beveled side away from the blade holder.

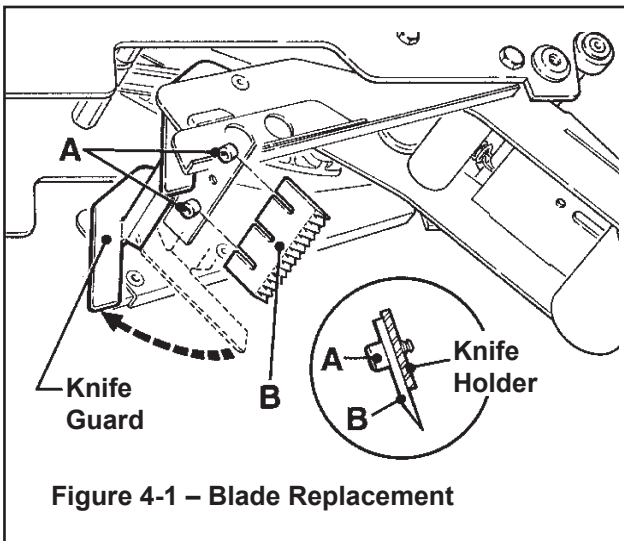

Figure 4-1 – Blade Replacement

3. Bottom the blade slots against the screws. (This will position the blade at the correct angle.) Tighten the blade screws to secure the blade.

Note – Check the blade position to insure proper clearance between blade and guard by slowly pivoting the blade guard back.

Blade Guard

The blade guard covers the blade whenever a box is not being taped. Periodically check to be sure the blade guard is functioning properly and returning to cover the blade. Replace any defective parts.

Blade Oiler Pad



WARNING

- **To reduce the risk associated with sharp blade hazards:**
 - Keep hands and fingers away from tape cutoff blades under orange blade guards. The blades are extremely sharp.

To reduce adhesive build-up, the taping heads are equipped with a factory pre-lubricated felt oiler pad that provides a film of oil on the cutting edge of the blade. Blade maintenance should include keeping the felt oiler pad saturated with SAE #30 non-detergent oil.

Should tape adhesive build-up occur on blade, carefully wipe clean with an oily cloth.

(Maintenance continued on next page.)



WARNING

- **To reduce the risk associated with shear, pinch, and entanglement hazards:**
 - Turn air and electrical supplies off on associated equipment before performing any adjustments, maintenance, or servicing the taping heads
 - Never attempt to work on the taping head or load tape while the box drive system is running
- **To reduce the risk associated with sharp blade hazards:**
 - Keep hands and fingers away from tape cutoff blades under orange blade guards. The blades are extremely sharp

Cleaning

Regular slotted containers produce a great deal of dust and paper chips when conveyed through taping heads. If this dust is allowed to build-up on the heads, it can cause wear on the moving parts. Excessive dirt build-up should be wiped off with a damp cloth. Cleaning should be done once per month, depending on the number and type of boxes used. If the boxes used are dirty, or if the environment in which the heads operate is dusty, cleaning on a more frequent basis may be necessary.

Note – Never attempt to remove dirt from taping heads by blowing it out with compressed air. This can cause the dirt to be blown inside the components onto sliding surfaces. Dirt in these areas can cause serious equipment damage. Never wash down or subject taping heads to conditions causing moisture condensation on components. Serious equipment damage could result.

Applying/Buffering Roller Replacement

Replacing roller requires removal of shaft and mounting screws. With no area on the shaft to grip, the shaft often turns when attempting to remove the second screw.

To ease removal of second screw, a 5mm hex socket has been provided at the bottom of the threads in both ends of the shaft. Insert a 4mm hex key wrench into this socket after removing one screw to hold the shaft for removal of the second screw. See **Figure 4-2**.

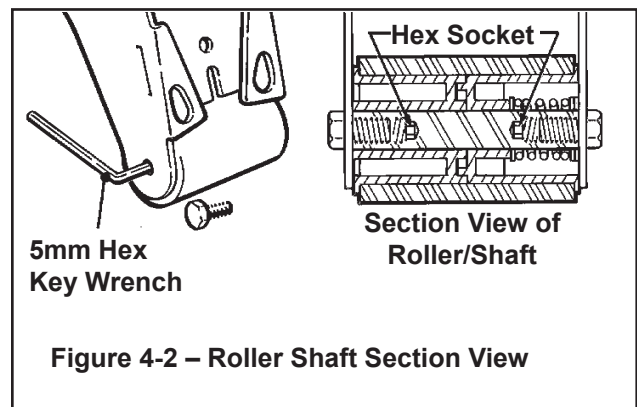



WARNING

- To reduce the risk associated with shear, pinch, and entanglement hazards:
- Turn air and electrical supplies off associated equipment before performing any adjustments, maintenance, or servicing the machine or taping heads.
- Never attempt to work on the taping head or load tape while the box drive system is running

Tape Latch Alignment – Figure 5-1

The Latching tape drum assembly is pre-set to accommodate 48mm [2 inch] wide tape. The tape drum assembly is adjustable to provide alignment of narrower tapes.

To move the latch to a position that corresponds to a new tape core width (**Figure 5-1**):

1. Remove screw from the latch.
2. Move to the latch to the position that corresponds to the tape core width.
3. Replace screw in the new latch location.

To adjust or center the tape width on the centerline of the taping head, and therefore box center seam, (**Figure 5-2**):

1. Loosen the locking hex nut behind tape drum bracket on tape drum shaft. Use an adjustable wrench or 25mm open end wrench.
2. Turn tape drum shaft in or out to center the tape web (use 5mm hex wrench).
3. Tighten locking hex nut to secure the adjustment.

No other components require adjustment for tape web alignment.

Tape Drum Friction Brake – Figure 5-3

The tape drum friction brake on each taping head is pre-set for normal operation to prevent tape roll over travel. Should tension adjustment be required, turn the self-locking nut on the shaft to vary compression of the spring. Turn the nut clockwise to increase the braking force, and counterclockwise to decrease the braking force. Adjust brake to minimum tension to prevent excessive tape roll over travel.

Note – Excess braking force will cause poor tape application and may lead to tape tabbing on the trailing tape leg.

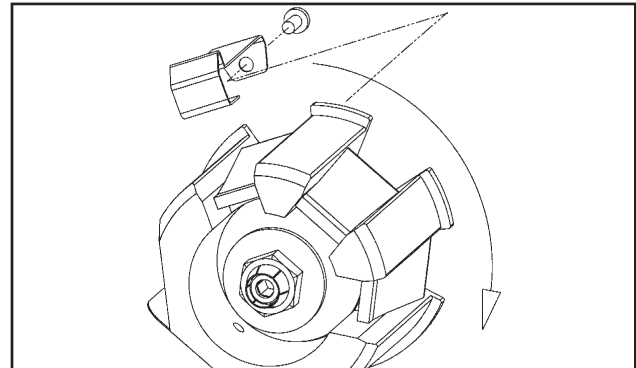

Figure 5-1 – Tape Latch Alignment

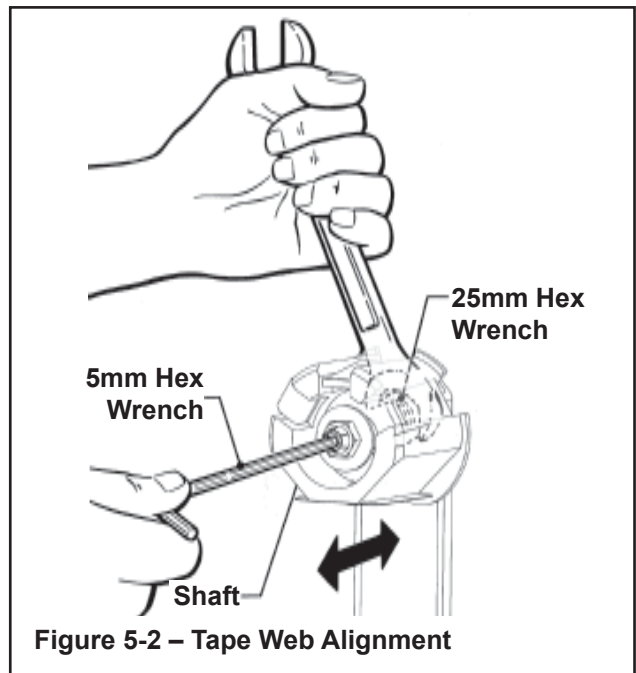

Figure 5-2 – Tape Web Alignment

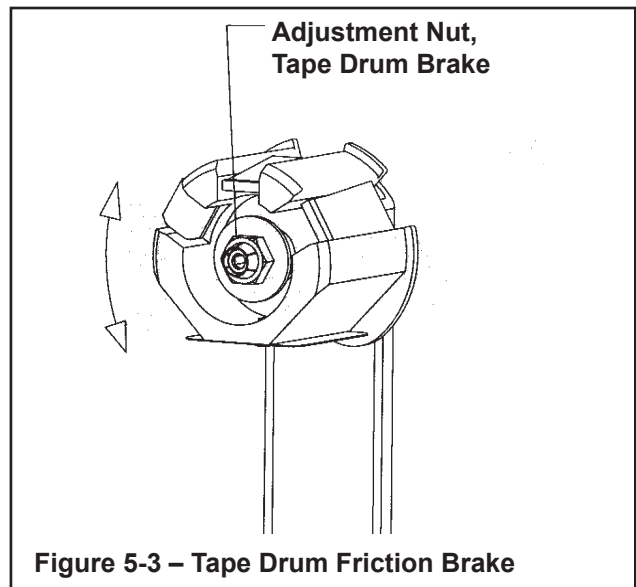

Figure 5-3 – Tape Drum Friction Brake

(Adjustments continued on next page.)



WARNING

- **To reduce the risk associated with shear, pinch, and entanglement hazards:**
 - Turn air and electrical supplies off associated equipment before performing any adjustments, maintenance, or servicing the machine or taping heads.
 - Never attempt to work on the taping head or load tape while the box drive system is running

Applying Mechanism Spring

To obtain access to the spring, remove the taping head cover (four mounting screws). Replace cover when finished.

The applying mechanism spring, shown in **Figures 5-4A and 5-4B**, controls applying and buffing roller pressure on the box and returns the mechanism to the reset position. The spring pressure is pre-set, as shown in **Figure 5-4A** for normal operation, but is adjustable.

If a tape gap appears on the trailing surface of the box increase spring pressure. If the front of the box is being crushed by the applying roller decrease spring pressure.

Removing the spring end loop from the spring holder and placing loop in other holes provided, as shown in **Figure 5-4B**, will adjust the spring pressure.

One-Way Tension Roller
Figure 5-5

The one-way tension roller is factory set. When replacing this assembly, the roller must have 0,5 kg [1 lb.] minimum tangential force when turning.

To Adjust Tension:

1. Wrap a cord or small strap (non-adhesive) 4-6 turns around the tension roller.
2. Attach a spring scale to the end of the cord or strap.
3. Turn the adjusting nut with the socket wrench provided, until a force of approximately 0.5 kg to 0.9 kg [1 to 2 lbs.] is required to turn the roller by pulling on the spring scale.

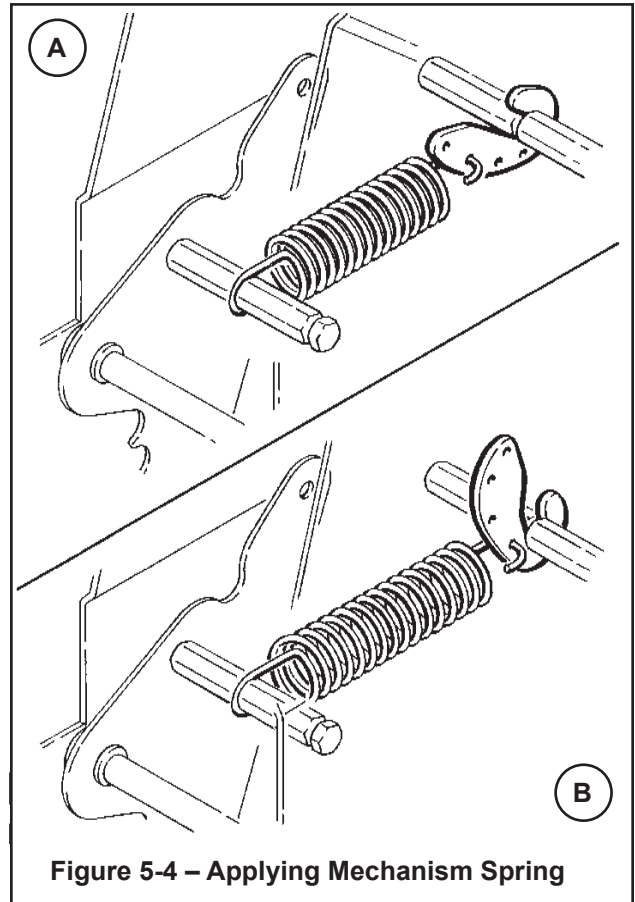

Figure 5-4 – Applying Mechanism Spring

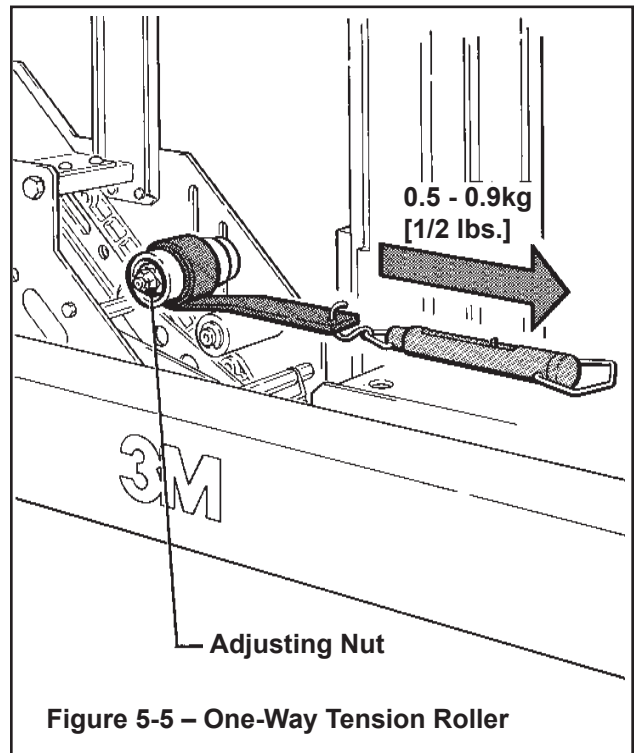

Figure 5-5 – One-Way Tension Roller

(Adjustments continued on next page.)



WARNING

- To reduce the risk associated with shear, pinch, and entanglement hazards:
- Turn air and electrical supplies off associated equipment before performing any adjustments, maintenance, or servicing the machine or taping heads.
- Never attempt to work on the taping head or load tape while the box drive system is running

Tape Leg Length



WARNING

- To reduce the risk associated with sharp blade hazards:
- Keep hands and fingers away from tape cutoff blades under orange blade guards. The blades are extremely sharp.

Leading Tape Leg Length Adjustment – Figure 5-6

The one-way tension roller position is adjustable to control the leading tape leg length.

Moving this roller farther away from the box top or bottom surface will decrease the leading leg length. Moving it closer to the box top or bottom surface will increase the leading leg length.

Changing Tape Leg Length from 70 to 50mm [2-3/4 to 2 Inches] – Figure 5-7

Note – When changing tape leg length, both upper and lower heads must be adjusted to apply the same leg lengths.

1. Remove and retain two hex head screws and remove the brush from normal position “A” on side frame.
2. Remount and secure brush in position “A-A” on side frame forward of normal location using original fasteners.
3. Remove cut-off bracket extensions from position “B”.
4. Remount cut-off bracket extensions in forward position “B-B”.
5. Remove and retain the one-way tension roller assembly from slot “C” in frame.
6. Remount tension roller assembly near top of slot “C-C” in frame using original fasteners.
7. Adjust tension roller according to "Leading Tape Leg Length Adjustment" above.

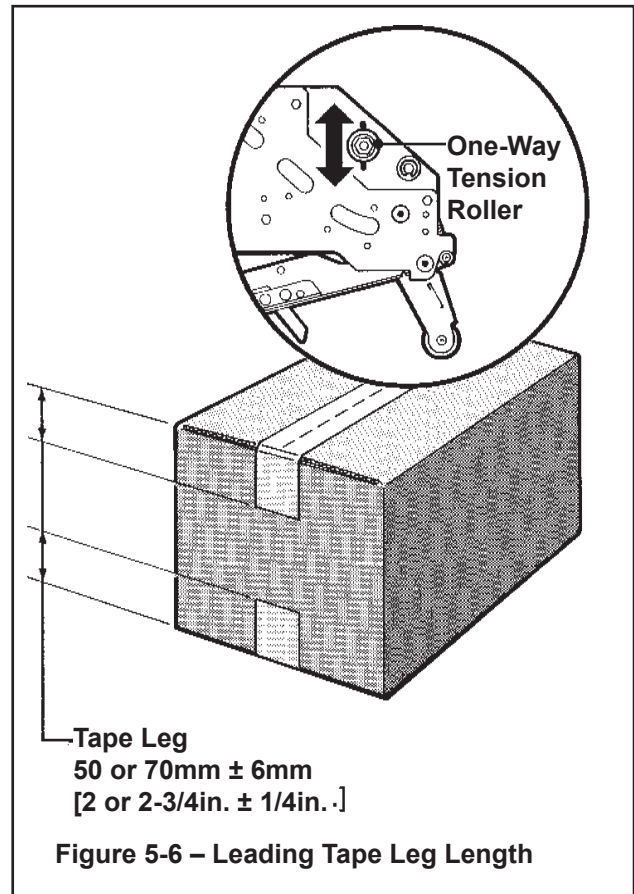

Figure 5-6 – Leading Tape Leg Length

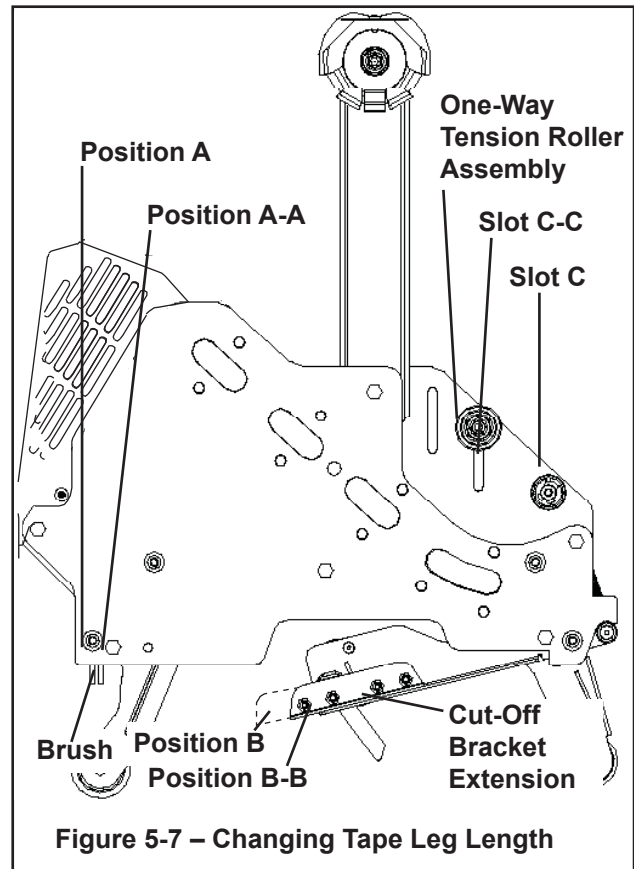

Figure 5-7 – Changing Tape Leg Length

Troubleshooting

Troubleshooting Guide

Problem	Cause	Correction
The tape leg on the front of the case is too long	The tape is threaded incorrectly	The tape must go around the wrap roller before going around the one-way tension roller
	The tape tension is too low	Adjust the one-way tension roller
	The knurled roller drags	Check for adhesive build-up between the knurled roller and its shaft. Clean and lubricate shaft. Remove all lubricant from roller surfaces.
	Tape tracks to one side or drags on the support tabs of applying frame	Adjust the tape web alignments
	The one-way tension roller is not correctly positioned	Position the roller in its mounting slot so that the tape extends just beyond the centerline of the applying roller
	Taping head is not set up properly	Check leg length adjustments
The blade does not cut tape or the tape end is jagged or shredded	The blade is dull and/or has broken teeth	Replace the blade
	Tape tension is insufficient	Increase tape tension by adjusting the one-way tension roller
	Adhesive has built up on the blade	Clean and adjust the blade
	The blade is not positioned properly	Make sure the blade is bottomed out against the mounting bolts
	The blade is dry	Lubricate the blade oiler pad on the blade guard
	The blade is in backwards	Mount the blade so that the beveled edge is away from the entrance of the head
	One or both cutter springs are missing or stretched	Replace the defective spring(s)
	Tension roller surface is not fully contacting the taping head frame	Make sure one-way bearing is below the surface of the tension roller. If not, press bearing further into roller or replace roller.

Troubleshooting (continued)

Troubleshooting Guide

Problem	Cause	Correction
Tape is tabbing on the trailing leg on the back of the box	There is excess tension on the tape drum assembly and/or the one-way tension roller assembly	Adjust the one-way tension roller and/or the tape drum assembly
	Rollers in the tape path do not rotate freely	Clean adhesive deposits from the surface, ends, and shafts of the rollers. Then lubricate roller shafts. Remove all lubricant from roller surfaces.
	The blade is not cutting tape properly	Refer to tape cutting problems
	The tape is threaded incorrectly	Re thread the tape
The tape end does not stay in application position in front of the applying roller	Applying mechanism spring has too little tension	Move spring hook to next tighter hole
	The tape is incorrectly threaded	Re thread the tape
	Flanged knurled roller overruns on return of applying mechanism to its rest position	Adjust tension roller position in mounting slot to lengthen tape leg
	Applying roller overruns on return of applying mechanism to its rest position	There should be a slight drag when rotating the applying roller. If not, check friction springs and/or friction pins and replace if necessary
	The one-way tension roller is not correctly positioned	Position roller in its mounting slot so that tape end extends beyond centerline of applying roller
Tape not centered on box seam	The one-way tension roller is defective	Replace the one-way tension roller
	Tape drum not centered	Reposition tape drum
	Centering guides not centered	Adjust centering guides
	Box flaps not of equal length	Check box specifications

Spare Parts/Service Information

Recommended Spare Parts

Listed are a set of spare parts that will periodically require replacement due to normal wear. These parts should be ordered to keep the taping heads in production:

AccuGlide™ 3 Upper Taping Head - 2 inch

Qty.	Part Number	Description
4	78-8076-4500-3	Stud – Mounting
1	78-8137-3311-6	Spring – Upper Extension
1	78-8017-9173-8	Blade – 65mm/2.56 Inch
2	78-8052-6602-6	Spring – Cutter
1	78-8076-4726-4	Tool – Tape Threading

AccuGlide™ 3 Lower Taping Head - 2 inch

Qty.	Part Number	Description
1	78-8017-9173-8	Blade – 65mm/2.56 Inch
2	78-8052-6602-6	Spring – Cutter
4	78-8076-4500-3	Stud – Mounting
1	78-8137-3312-4	Spring – Lower Extension
1	78-8076-4726-4	Tool – Tape Threading

In addition to the above set of spare parts supplied with the taping head, it is suggested that the following spare parts be maintained which will require replacement under normal wear of the taping head.

Qty.	Part Number	Description
1	78-8057-6179-4	Roller – Applying
1	78-8057-6178-6	Roller – Buffing
1	78-8113-7030-9	Spring – Torsion

Replacement Parts and Service

Refer to the first page of this instruction manual “**Replacement Parts and Service Information**”.

Replacement Parts Illustrations and Parts Lists

AccuGlide™ 3 High Speed 2 Inch Upper Taping Head, Type 10800

AccuGlide™ 3 High Speed 2 Inch Lower Taping Head, Type 10800

1. Refer to the **Taping Head Assemblies** Figure to find all the parts illustrations identified by **figure numbers**.
2. Refer to the figure or figures to determine the **individual parts** required and the **parts reference number**.
3. The **replacement parts list**, that follows each illustration, includes the **part number** and **part description** for the parts in that illustration.

Note – The complete description has been included for standard fasteners and some commercially available components. This has been done to allow obtaining these standard parts locally, should the customer elect to do so.

4. Refer to the first page of this instruction manual "**Replacement Parts and Service Information**" for replacement parts ordering information.

Important – Not all the parts listed are normally stocked items. Some parts or assemblies shown are available only on a special order basis. Contact 3M/Tape Dispenser Parts to confirm item availability.

Tape Head -
AccuGlide™ 3 - 2 inch

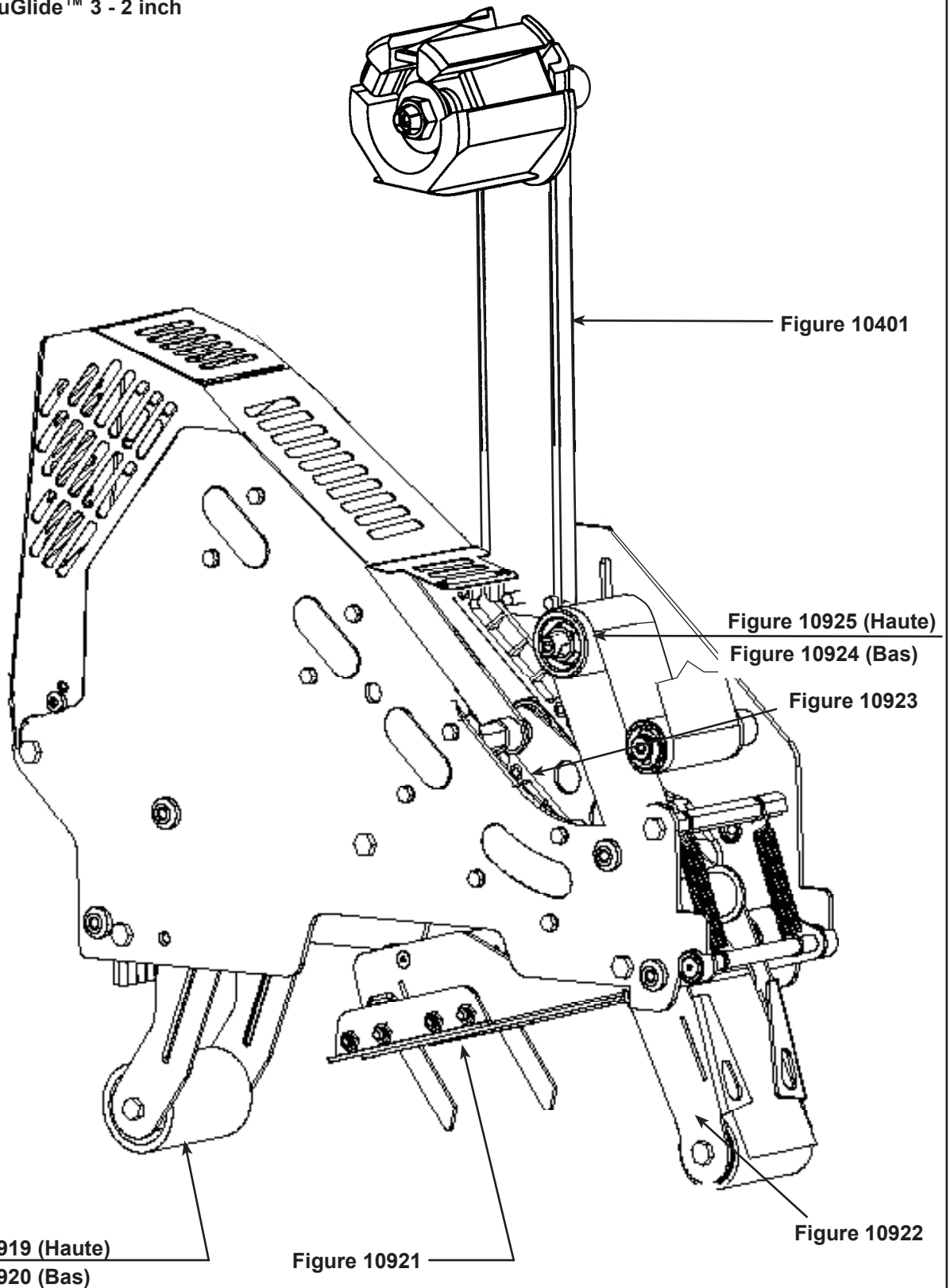

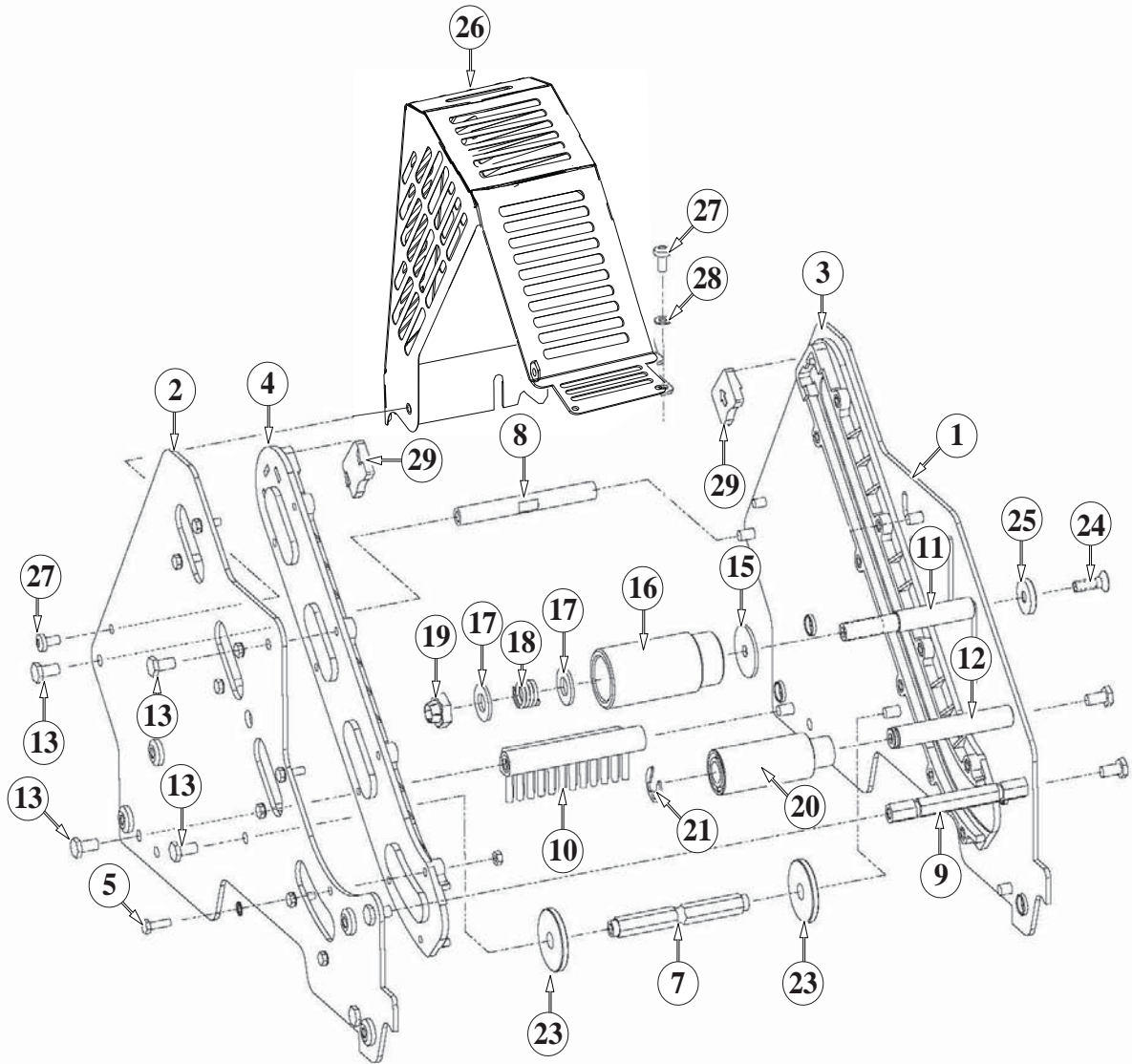

Figure 10925 – Upper Head

AccuGlide™ 3 - 2"

Figure 10925 – 2" Upper Head

Ref. No.	3M Part No.	Description
10925-1	78-8137-3294-4	Frame – Tape Mount Upper Assembly
10925-2	78-8137-3295-1	Frame – Front Upper Assembly
10925-3	78-8068-4143-9	Guide – #1
10925-4	78-8068-4144-7	Guide – #2
10925-5	78-8060-7818-0	Screw – Hex Hd, M4 x 12
10925-6	78-8010-7416-8	Nut – Hex Jam, M4
10925-7	78-8070-1251-9	Spacer – Spring
10925-8	78-8137-3298-5	Shaft - Pivot 90mm
10925-9	78-8052-6560-6	Spacer – Front
10925-10	78-8060-7936-0	Brush Assembly
10925-11	78-8052-6564-8	Shaft – Tension Roller
10925-12	78-8052-6568-9	Shaft – Wrap Roller
10925-13	26-1003-5829-5	Screw – Hex Hd, M6 x 12
10925-15	78-8100-1009-6	Washer – Special
10925-16	78-8052-6565-5	Roller – Top Tension
10925-17	26-1004-5510-9	Washer – Plain, M10
10925-18	78-8052-6567-1	Spring – Compression
10925-19	78-8017-9077-1	Nut – Self Locking, M10 x 1
10925-20	78-8052-6569-7	Roller – Wrap
10925-21	26-1000-1613-3	Ring – Retaining, Tru-Arc #1-420-0120-100
10925-22	78-8076-4500-3	Stud – Mounting (not shown)
10925-23	78-8076-5242-1	Stop – Cut-Off Frame
10925-24	78-8060-8179-6	Screw – Flat Hd Hex, M6 x 20
10925-25	78-8076-5477-3	Washer – Special /6.5 x 20 x 4
10925-26	78-8137-3299-3	Guard – Head
10925-27	78-8060-8087-1	Screw – M5 x 10
10925-28	78-8005-5741-1	Washer – Flat, M5
10925-29	78-8133-9615-3	Bumper
10925-30	78-8133-9605-4	Label – Threading, English Language
10925-31	78-8076-4716-5	Star Washer 4mm

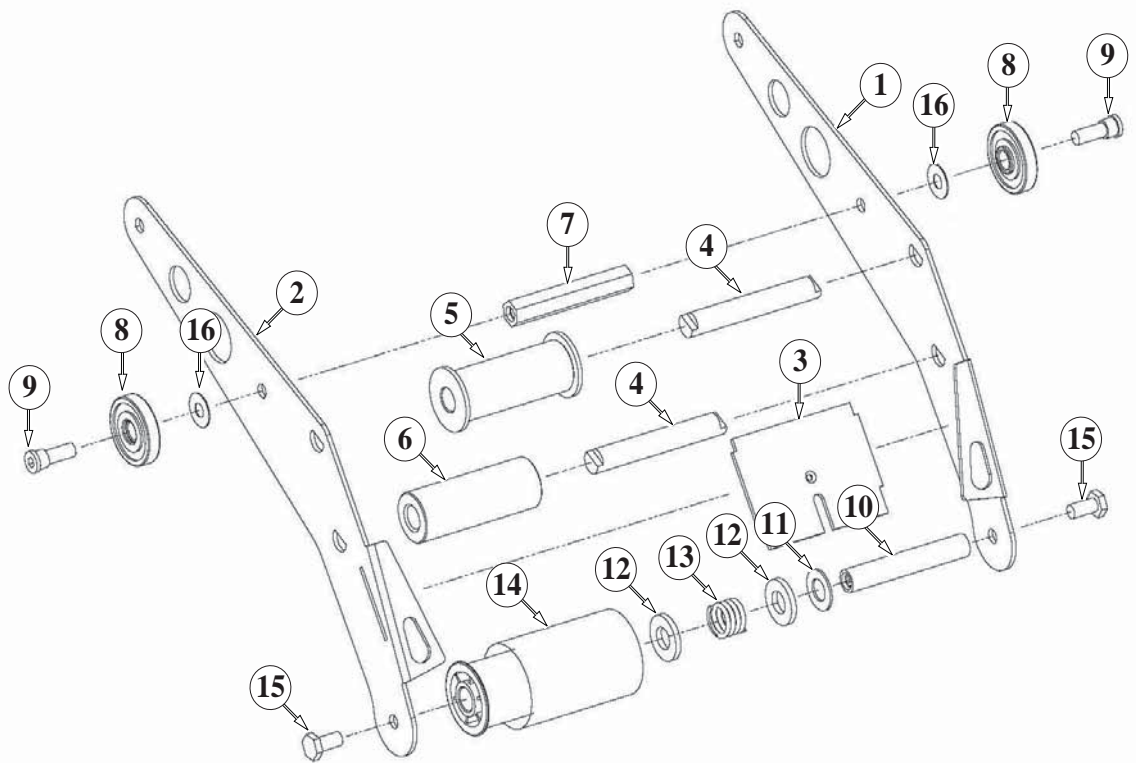

Figure 10922 – Upper and Lower Heads

AccuGlide™ 3 - 2"

Figure 10922 – 2" Upper and Lower Heads

Ref. No.	3M Part No.	Description
10922-1	78-8133-9509-8	Applying Arm #1
10922-2	78-8133-9510-6	Applying Arm #2
10922-3	78-8070-1221-2	Plate – Tape
10922-4	78-8070-1309-5	Shaft Roller
10922-5	78-8070-1367-3	Roller – Knurled Assembly
10922-6	78-8070-1266-7	Roller – Wrap
10922-7	78-8052-6580-4	Spacer
10922-8	78-8017-9082-1	Bearing – Special, 30 mm
10922-9	78-8017-9106-8	Screw – Bearing Shoulder
10922-10	78-8052-6575-4	Shaft – Roller
10922-11	78-8017-9074-8	Washer – Nylon, 15 mm
10922-12	26-1004-5510-9	Washer – Friction
10922-13	78-8052-6567-1	Spring – Compression
10922-14	78-8137-1438-9	Assembly– Applying Roller
10922-15	26-1003-5829-5	Screw – Hex Hd, M6 x 12
10922-16	78-8094-6151-6	Washer - Flat, 6.5 ID x 15 OD x 0.5 Thk

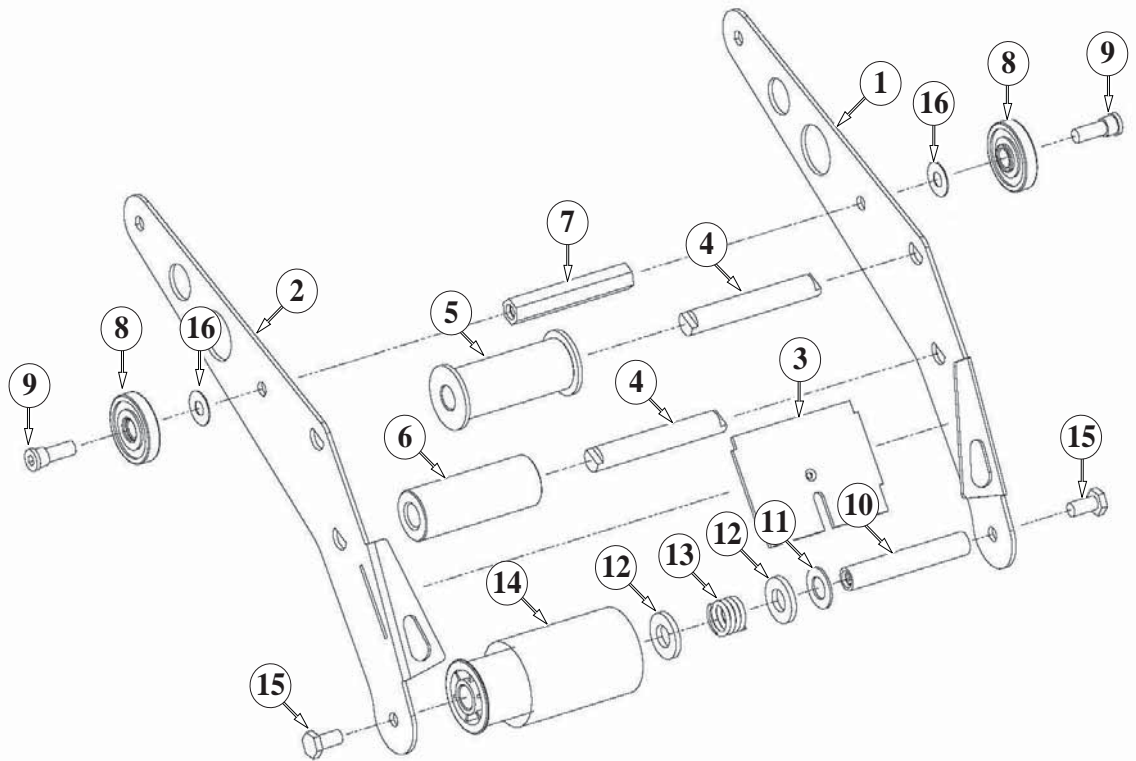

Figure 10919 – Upper Head

AccuGlide™ 3 - 2"

Figure 10919 – 2" Upper Head

Ref. No.	3M Part No.	Description
10919-1	78-8137-3300-9	Buffing Arm – Sub Assembly
10919-2	78-8137-3301-7	Buffing Arm – Sub Assembly
10919-3	78-8052-6575-4	Shaft – Roller
10919-4	78-8137-1398-5	Roller - Buffing Assembly
10919-5	78-8070-1220-4	Spacer – Spring
10919-6	78-8052-6580-4	Spacer
10919-7	26-1003-5829-5	Screw – Hex Hd, M6 x 12
10919-8	78-8137-3311-6	Spring – Upper (100 fpm)
10919-9	78-8070-1244-4	Holder – Spring

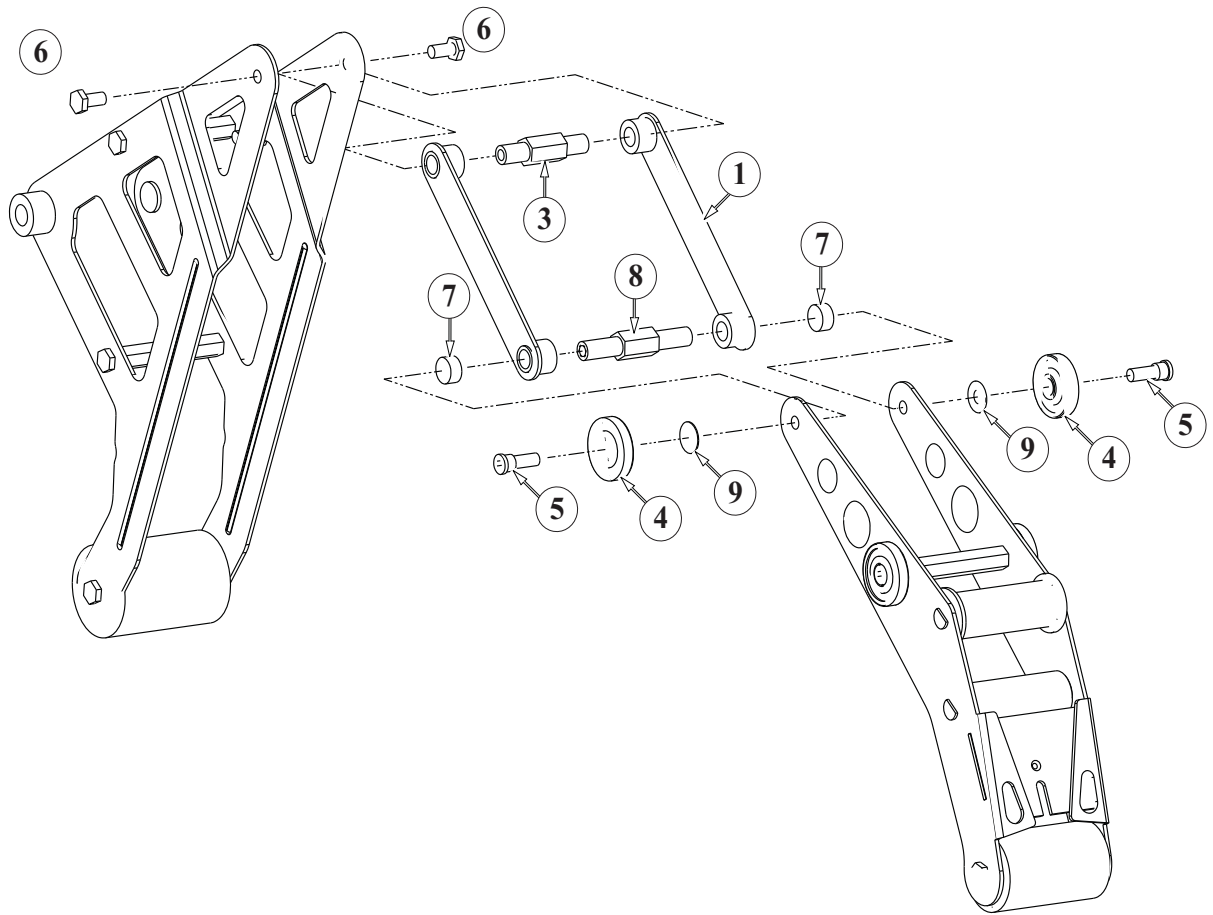

Figure 10923 – Upper and Lower Heads

AccuGlide™ 3 - 2"

Figure 10923 – 2" Upper and Lower Heads

Ref. No.	3M Part No.	Description
10923-1	78-8137-3302-5	Link – Assembly
10923-3	78-8137-3304-1	Shaft – Pivot, Buffing
10923-4	78-8017-9082-1	Bearing – Special 30 mm
10923-5	78-8017-9106-8	Screw – Bearing Shoulder
10923-6	26-1003-5829-5	Screw – Hex Hd, M6 x 12
10923-7	78-8137-3305-8	Spacer – Applying Pivot
10923-8	78-8137-3306-6	Shaft – Pivot, Applying
10923-9	78-8094-6151-6	Washer - Flat, 6.5 ID x 15 OD x 0.5 Thk

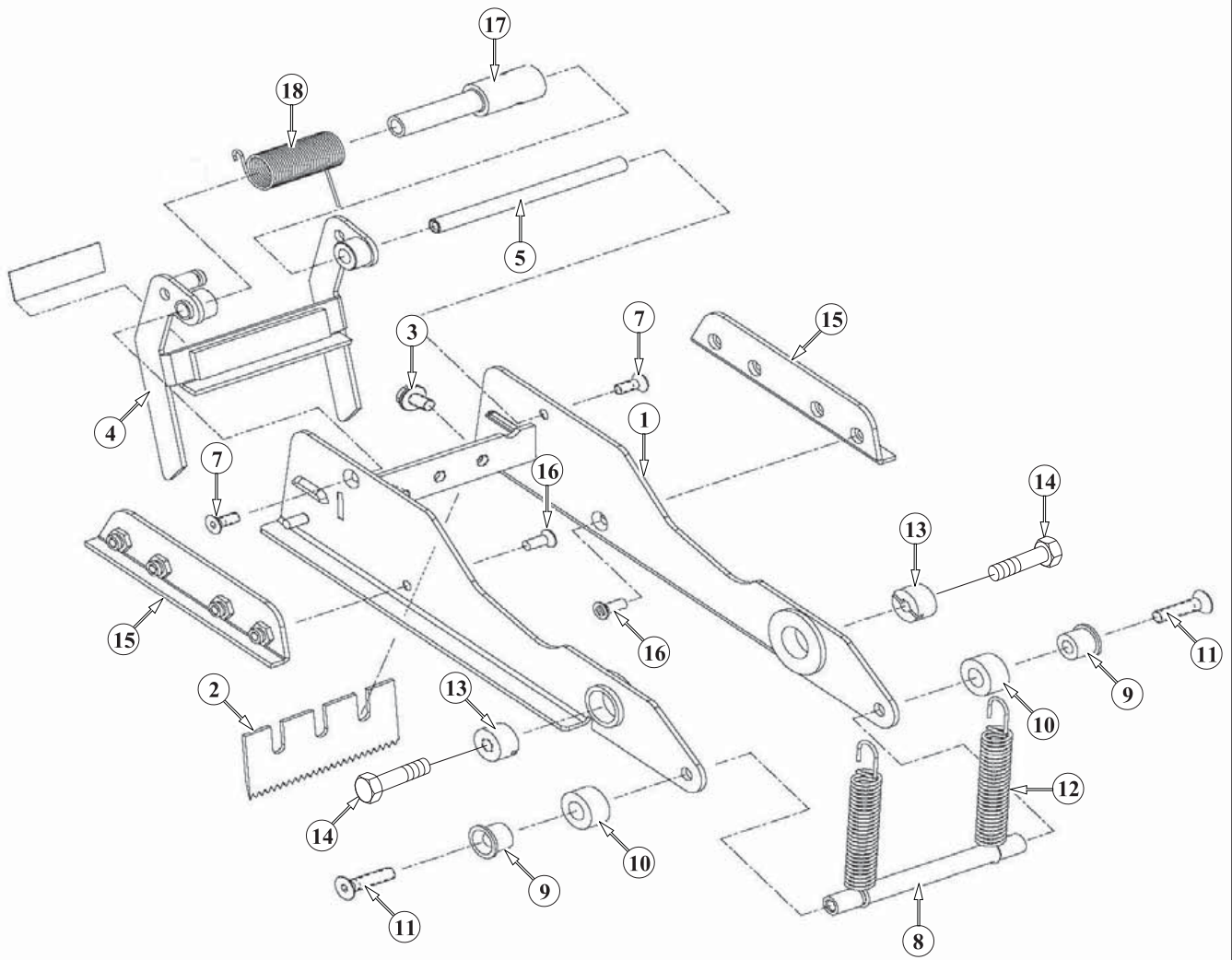

Figure 10921 – Upper and Lower Heads

AccuGlide™ 3 - 2"

Figure 10921 – 2" Upper and Lower Heads

Ref. No.	3M Part No.	Description
10921-1	78-8137-3307-4	Frame – Cut-Off Weldment
10921-2	78-8017-9173-8	Blade – 65 mm/2.56 Inch
10921-3	26-1003-8596-7	Screw - Hex Hd M5 x 8 w/ Ext. Tooth Lockwasher
10921-4	78-8070-1371-5	Blade Guard Assembly – W/English Language Label
10921-5	78-8052-6597-8	Shaft – Blade Guard
10921-7	26-1005-4758-2	Screw – Flat Hd, Soc Dr, M4 x 10
10921-8	78-8017-9135-7	Shaft – Spacer
10921-9	78-8052-6600-0	Spacer
10921-10	78-8070-1269-1	Bumper
10921-11	26-1005-4757-4	Screw – Flat Hd, Soc Dr, M5 x 20
10921-12	78-8052-6602-6	Spring – Cutter
10921-13	78-8017-9132-4	Pivot – Cutter Lever
10921-14	26-1003-5828-7	Screw – Spec, Hex Hd, M6 x 10
10921-15	78-8137-3308-2	Slide – Extension
10921-16	26-1008-6574-5	Screw – Flat Hd, Phil Dr, M4 x 10
10921-17	78-8113-7031-7	Bushing – 58.5mm Long
10921-18	78-8113-7030-9	Spring – Torsion
10921-19	78-8070-1335-0	Label – Warning, English

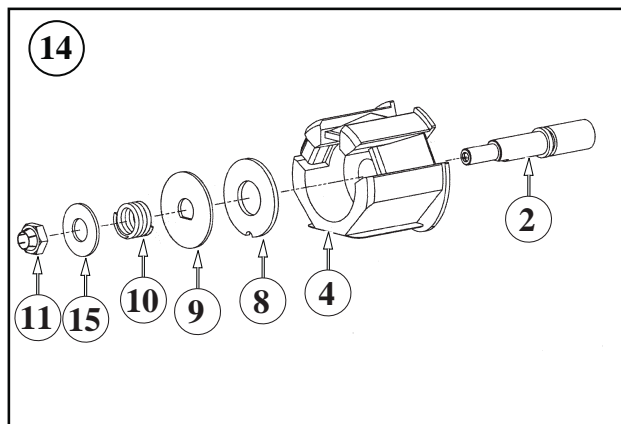
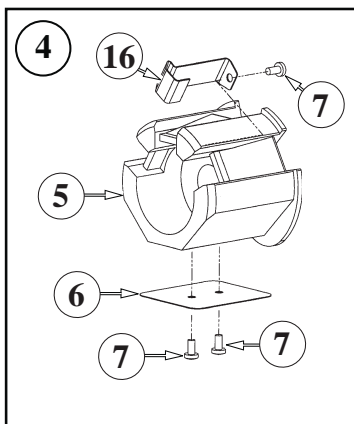
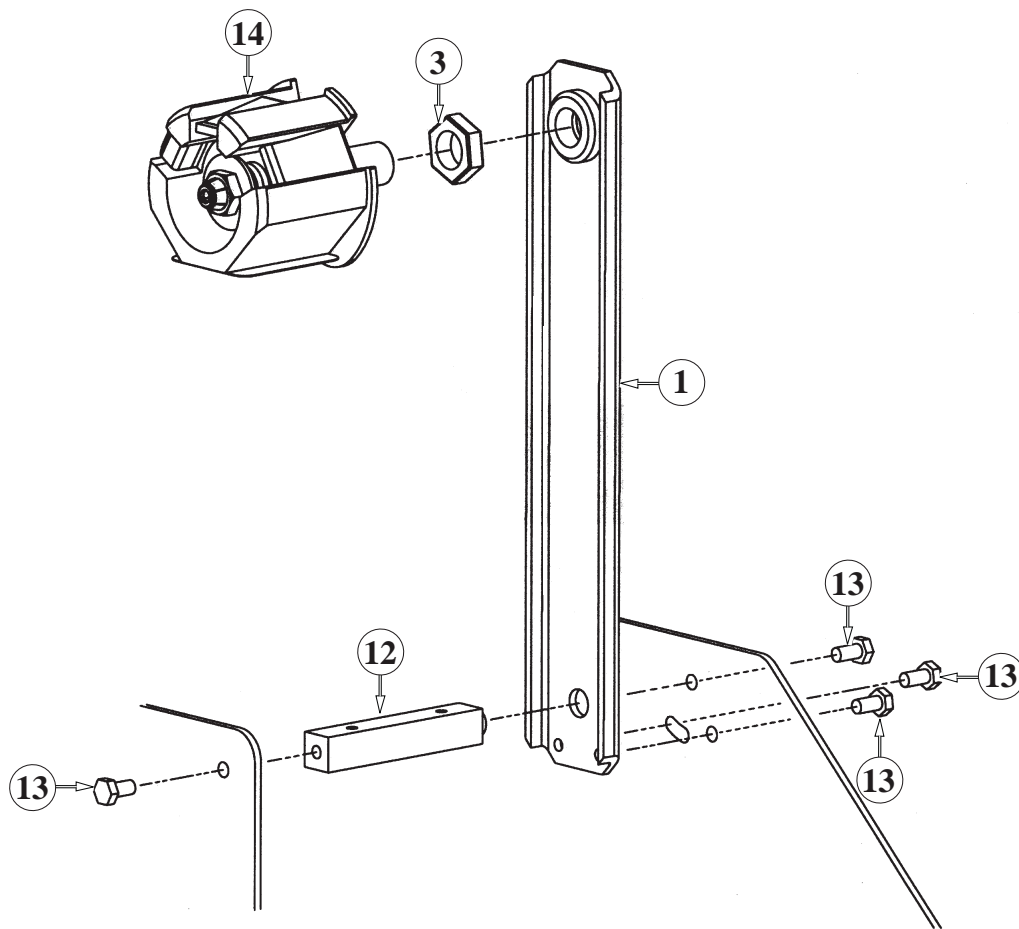

Figure 10401 – Upper and Lower Heads

AccuGlide™ 3 - 2"

Figure 10401 – 2" Latch Upper and Lower Heads

Ref. No.	3M Part No.	Description
10401-1	78-8070-1395-4	Bracket – Bushing Assembly
10401-2	78-8076-4519-3	Shaft – Tape Drum, 50mm
10401-3	78-8017-9169-6	Nut – M18 x 1
10401-4	78-8098-8827-0	Tape Drum Sub Assembly – 2 Inch Wide
10401-5	78-8098-8749-6	Tape Drum
10401-6	78-8098-8817-1	Leaf Spring
10401-7	26-1002-5753-9	Screw – Self Tapping
10401-8	78-8060-8172-1	Washer – Friction
10401-9	78-8052-6271-0	Washer – Tape Drum
10401-10	78-8100-1048-4	Spring – Core Holder
10401-11	78-8017-9077-1	Nut – Self Locking, M10 x 1
10401-12	78-8100-1046-8	Spacer – Bracket
10401-13	26-1003-5829-5	Screw – Hex Hd, M6 x 12
10401-14	78-8098-8814-8	Tape Drum Assembly – 2 Inch Head
10401-15	26-1004-5510-9	Washer – Plain, M10
10401-16	78-8098-8816-3	Latch – Tape Drum

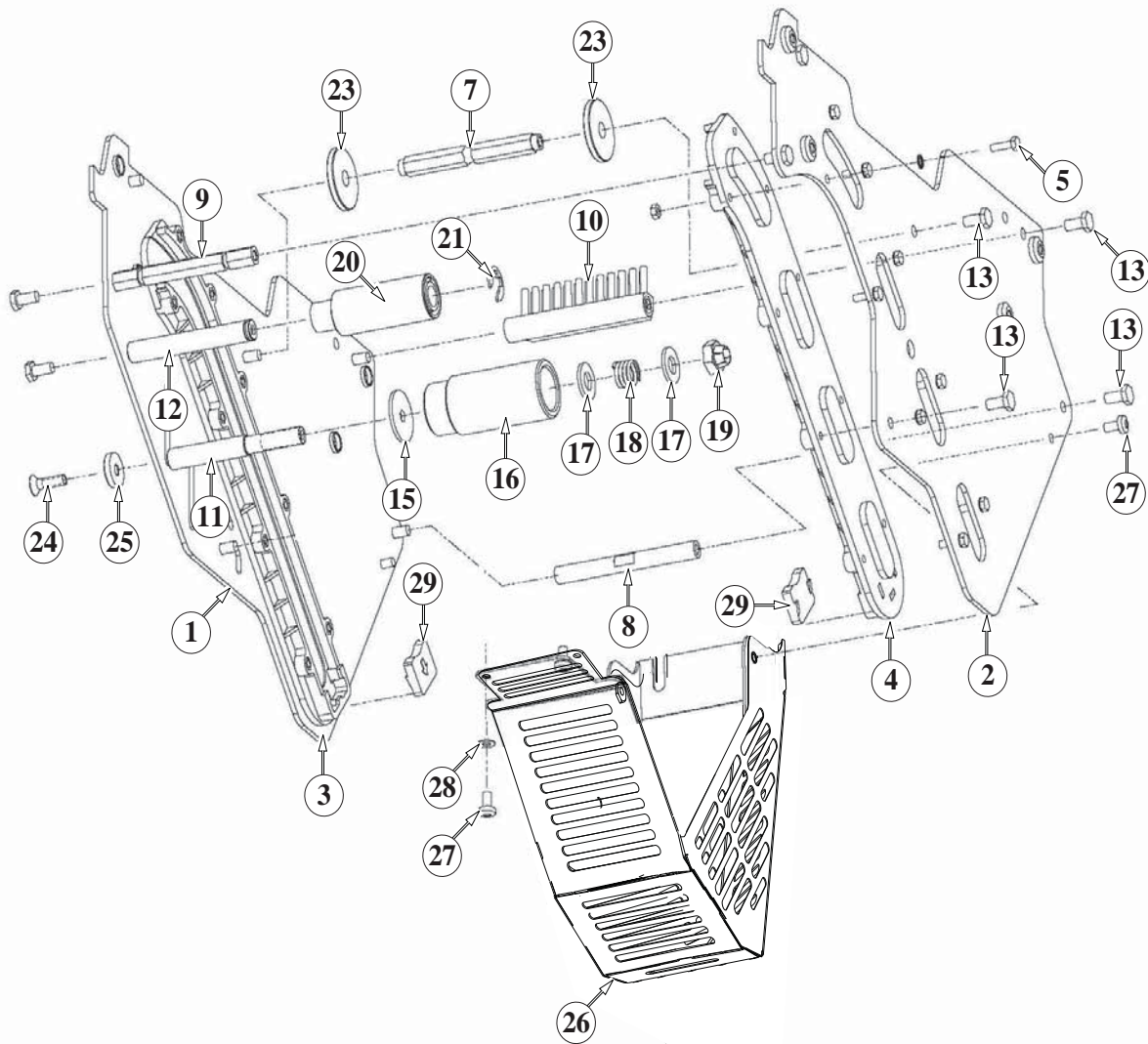

Figure 10924 – Lower Head

AccuGlide™ 3 - 2"

Figure 10924 – 2" Lower Head

Ref. No.	3M Part No.	Description
10924-1	78-8137-3296-9	Frame – Tape Mount Lower Assembly
10924-2	78-8137-3297-7	Frame – Front Lower Assembly
10924-3	78-8068-4144-7	Guide – #2
10924-4	78-8068-4143-9	Guide – #1
10924-5	78-8060-7818-0	Screw – Hex Hd, M4 x 12
10924-6	78-8010-7416-8	Nut – Hex, M4
10924-7	78-8070-1251-9	Spacer – Spring
10924-8	78-8054-3298-5	Spacer – 10 x 10 x 90 mm
10924-9	78-8052-6560-6	Spacer – Front
10924-10	78-8060-7936-0	Brush Assembly
10924-11	78-8052-6564-8	Shaft – Tension Roller
10924-12	78-8052-6568-9	Shaft – Wrap Roller
10924-13	26-1003-5829-5	Screw – Hex Hd, M6 x 12
10924-15	78-8100-1009-6	Washer – Special
10924-16	78-8052-6606-7	Roller – Tension Bottom
10924-17	26-1004-5510-9	Washer – Plain, M10
10924-18	78-8052-6567-1	Spring – Compression
10924-19	78-8017-9077-1	Nut – Self Locking, M10 x 1
10924-20	78-8052-6569-7	Roller – Wrap
10924-21	26-1000-1613-3	Ring – Retaining, Tru-Arc #1-420-0120-100
10924-22	78-8076-4500-3	Stud – Mounting (not shown)
10924-23	78-8076-5242-1	Stop – Cut-Off Frame
10924-24	78-8060-8179-6	Screw – Flat Hd Hex, M6 x 20
10924-25	78-8076-5477-3	Washer – Special /6.5 x 20 x 4
10924-26	78-8137-3299-3	Guard – Head
10924-27	78-8060-8087-1	Screw – M5 x 10
10924-28	78-8005-5741-1	Washer – Flat, M5
10924-29	78-8076-4734-8	Bumper
10924-30	78-8133-9606-2	Label – Threading, English Language
10924-31	78-8076-4716-5	Star Washer 4mm

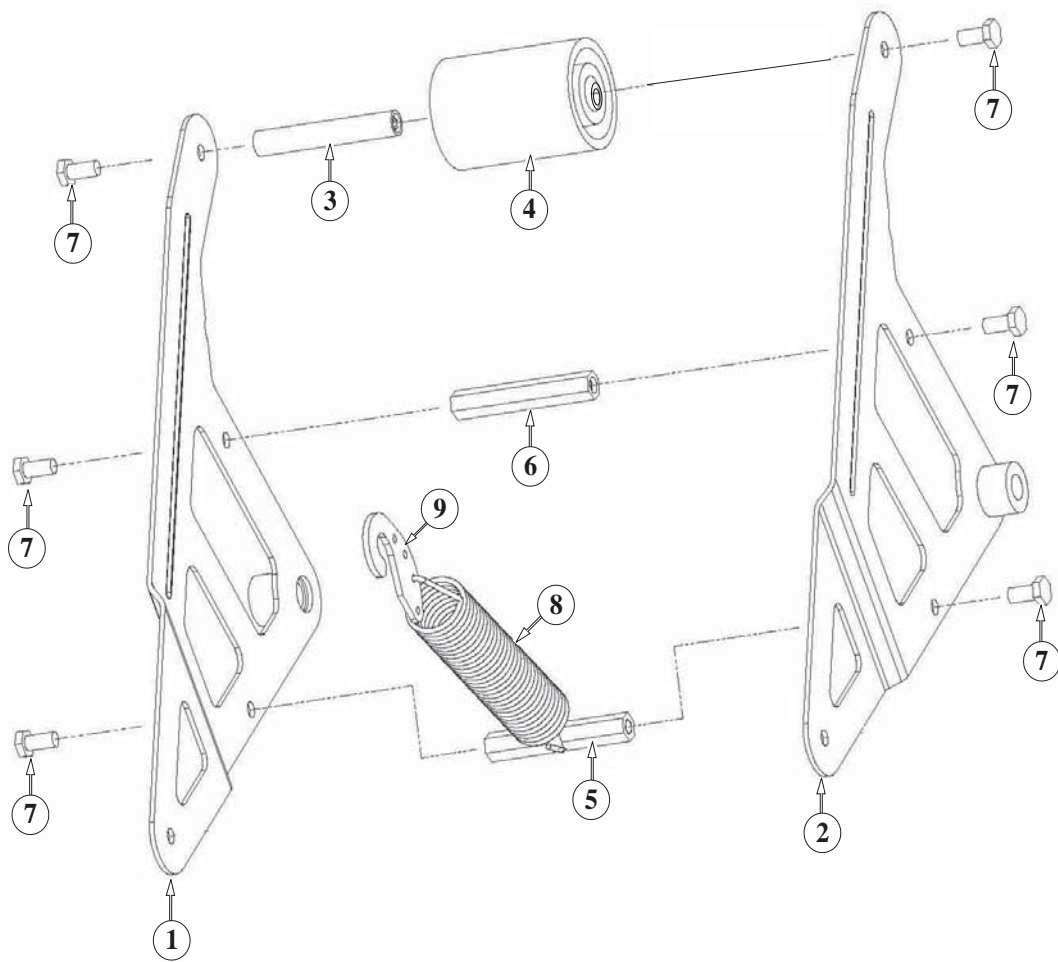

Figure 10920 – Lower Head

AccuGlide™ 3 - 2"

Figure 10920– Lower Head

Ref. No.	3M Part No.	Description
10920-1	78-8137-3300-9	Buffing Arm – Sub Assembly
10920-2	78-8137-3301-7	Buffing Arm – Sub Assembly
10920-3	78-8052-6575-4	Shaft – Roller
10920-4	78-8137-1398-5	Roller - Buffing Assembly
10920-5	78-8070-1220-4	Spacer – Spring
10920-6	78-8052-6580-4	Spacer
10920-7	26-1003-5829-5	Screw – Hex Hd, M6 x 12
10920-8	78-8137-3312-4	Spring – Lower (100 fpm)
10920-9	78-8070-1244-4	Holder – Spring

THIS PAGE IS BLANK

Free Manuals Download Website

<http://myh66.com>

<http://usermanuals.us>

<http://www.somanuals.com>

<http://www.4manuals.cc>

<http://www.manual-lib.com>

<http://www.404manual.com>

<http://www.luxmanual.com>

<http://aubethermostatmanual.com>

Golf course search by state

<http://golfingnear.com>

Email search by domain

<http://emailbydomain.com>

Auto manuals search

<http://auto.somanuals.com>

TV manuals search

<http://tv.somanuals.com>