

MEGABIT MODEM 310F AND 320F USER MANUAL



Catalog Number
MMD4067I2 Issue 2



Copyright

June 11, 2002

©2002 ADC DSL Systems, Inc. All rights reserved.

Information contained in this document is company private to ADC DSL Systems, Inc., and shall not be modified, used, copied, reproduced or disclosed in whole or in part without written consent of ADC.

Trademark Information

ADC is a registered trademark of ADC Telecommunications, Inc.

Megabit Modem is a registered trademark of DSL Systems, Inc. No right, license, or interest to such trademarks is granted hereunder, and you agree that no such right, license, or interest shall be asserted by you with respect to such trademark.

Other product names mentioned in this manual are used for identification purposes only and may be trademarks or registered trademarks of their respective companies.

Disclaimer of Liability

Contents herein are current as of the date of publication. ADC reserves the right to change the contents without prior notice. In no event shall ADC be liable for any damages resulting from loss of data, loss of use, or loss of profits, and ADC further disclaims any and all liability for indirect, incidental, special, consequential or other similar damages. This disclaimer of liability applies to all products, publications and services during and after the warranty period.

Specific Disclaimer for High-risk Activities

This product is not designed or intended for use in high-risk activities, including, without restricting the generality of the foregoing, on-line control of aircraft, air traffic, aircraft navigation or aircraft communications; or in the design, construction, operation or maintenance of any nuclear facility. ADC (including its affiliates) and its suppliers specifically disclaim any express or implied warranty of fitness for such purposes or any other purposes.

ABOUT THIS MANUAL

This manual is intended to help a network administrator install and configure the ADC[®] Megabit Modem 310F and 320F for use in a private network environment. It includes:

- a summary of the modem features and suggested applications
- instructions for installing and configuring the modems
- explanation of the performance monitoring screens
- technical specifications and cabling pinouts
- a glossary

DOCUMENT CONVENTIONS

Two types of messages, identified by icons, are used throughout the document:



Notes contain information about special circumstances.



Cautions indicate the possibility of equipment damage or the possibility of personal injury.

PRODUCT CERTIFICATIONS

FCC

Megabit Modem

This equipment has been tested and found to comply with the limits for a Class B digital device, pursuant to Part 15 of the FCC Rules. These limits are designed to provide reasonable protection against harmful interference when the equipment is operated in a commercial environment. This equipment generates, uses, and can radiate radio frequency energy and, if not installed and used in accordance with this instruction manual, may cause harmful interference to radio communication.

However, there is no guarantee that interference will not occur in a particular installation. If this equipment does cause harmful interference to radio or television reception, which can be determined by turning the equipment off and on, the user is encouraged to try to correct the interference by one or more of the following measures:

- Reorient or relocate the receiving antenna.
- Increase the separation between the equipment and receiver.
- Connect the equipment into an outlet on a circuit different from that to which the receiver is connected.
- Consult the dealer or an experienced radio/TV technician for help.

cUL

This product meets all safety requirements per UL-1950 standard.

TABLE OF CONTENTS

Chapter 1: Megabit Modem 310F and 320F Features and Applications	1
Features.....	1
Applications.....	2
Chapter 2: Installing the Megabit Modem 310F and 320F.....	3
Unpacking and Inspecting the Shipment.....	3
Attaching the Feet.....	4
Identifying The Connectors.....	5
Installing the Cabling	6
Identifying LEDs.....	7
Powering Up and Checking LEDs	8
Chapter 3: Preparing for Configuration and Management	9
Connecting a Terminal	9
Configuring the Terminal.....	10
Logging On and Navigating the Interface	10
Logging On to the Local Modem.....	10
Logging On to the Remote Modem	12
Navigating the Interface.....	13
Logging Off	14
Chapter 4: Configuring the Modems.....	15
Setting System Configurations	15
Changing the System Time	16
Changing the System Date	16
Changing the Logon Password.....	17
Restoring Factory Default Settings.....	18
Disabling or Enabling the RS-232 Port For the Megabit Modem 320F	19

Configuring ADSL Service	20
Configuring the Startup Settings	21
Configuring Data Rates	22
Configuring the SNR Margin Threshold.....	23
Configuring the ES Threshold.....	23
Configuring Alarms.....	24
Configuring the Interleave Options	25
Saving ADSL Configuration Changes	25
Resetting the ADSL Link	26
Configuring Bridge Parameters	27
Configuring Bridge Aging Time	27
Configuring the Source Address Database.....	28
Resetting the Bridge	30
Chapter 5: Monitoring Circuit Status and Displaying System Information.....	31
Monitoring ADSL Status	31
Monitoring ADSL Performance Status	32
Monitoring 24 Hour ADSL Performance History.....	34
Monitoring 7 Day ADSL Performance History	35
Monitoring ADSL Alarm History	36
Monitoring Ethernet Bridge Statistics	38
Displaying System Information	41
MAC Layer Bridging.....	43
Data Encapsulation	43
Ethernet Frame Rates.....	44
Minimum xDSL Bit Stuffing, One Additional Bit.....	44
Maximum xDSL Bit Stuffing, Zero Additional Bits.....	46

Rate Adaptive Transmission.....	47
Rate Adaptation.....	48
Reach, Data Rate, SNR Margin, and Noise Environment	48
Technical Specifications.....	51
Compliance.....	52
Connector Pinouts	53
Limited Warranty	56

MEGABIT MODEM 310F AND 320F FEATURES AND APPLICATIONS

1

The ADC® Megabit Modem® 310F and 320F use Asymmetric Digital Subscriber Line (ADSL) technology to provide a multi-megabit connection between the two modems using a single-pair telephone line. The Megabit Modem 310F and 320F are designed to be used together, one at each end of a circuit, with the model 310F functioning as the ATU-C and the model 320F functioning as the ATU-R. The Megabit Modem 310F and 320F use Discrete MultiTone (DMT) line coding. In addition, ADSL technology allows POTS (Plain Old Telephone Service) to coexist with the high-speed data service on the same wire pair.

The Megabit Modem 310F and 320F support the full DMT rate of 64 kbps to 7040 kbps downstream and 64 kbps to 928 kbps upstream. The Megabit Modem 310F and 320F can be used in either rate adaptive mode, in which the modem speed automatically adjusts to the maximum attainable data rate depending on distance and line condition, or you can select a fixed rate.

FEATURES

Megabit Modem 310F and 320F features include:

- 10BASE-T Ethernet port for LAN connection
- ADSL port for ADSL connection
- IEEE 802.1d transparent MAC layer bridging of frames received on the LAN port
- full DMT transmission rates
 - 64 kbps to 7040 kbps downstream
 - 64 kbps to 928 kbps upstream
- RS-232 port for management

The Spanning Tree protocol is not supported in the Megabit Modem 310F or 320F.

APPLICATIONS

Use the Megabit Modem 310F and 320F for:

- remote access to private networks, for example telecommuting
- point-to-point LAN extension, for example connecting multiple users at a satellite office to a corporate office LAN

Telecommuting Application

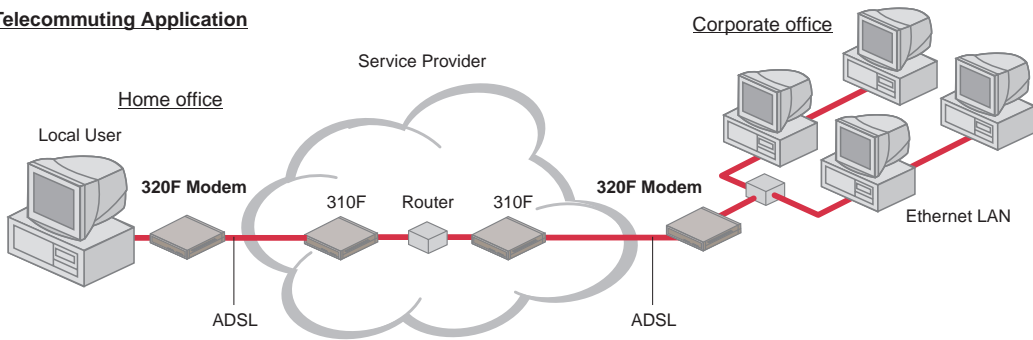

LAN Extension Application

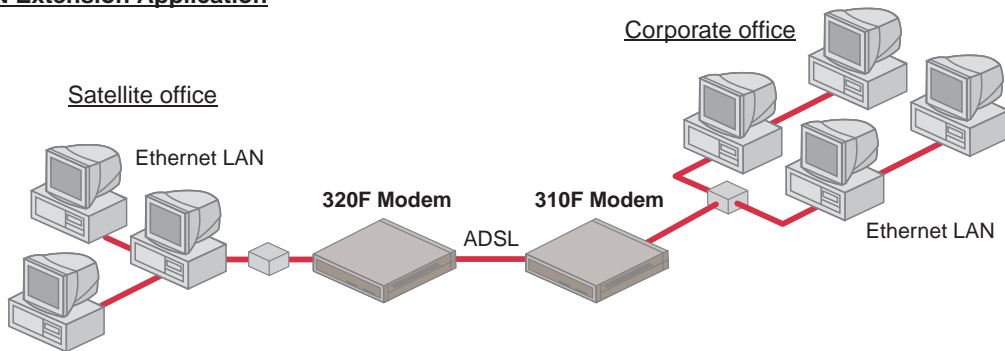

INSTALLING THE MEGABIT MODEM 310F AND 320F

2

Install a Megabit Modem 310F (ATU-C) at one end of a circuit and a Megabit Modem 320F at the other end (ATU-R), using the procedures described in these sections:

UNPACKING AND INSPECTING THE SHIPMENT

The shipping carton contains the Megabit Modem 310F or 320F, this manual and the items described on [page 4](#). Upon receipt of the equipment:

- 1** Unpack each container and visually inspect it for signs of damage. If the equipment has been damaged in transit, immediately report the extent of damage to the transportation company and to your sales representative. Order replacement equipment if necessary.
- 2** Check the shipment contents against the packing list to ensure complete and accurate shipment. If the shipment is short or irregular, contact your sales representative. If you must store the equipment for a prolonged period, store the equipment in its original container.

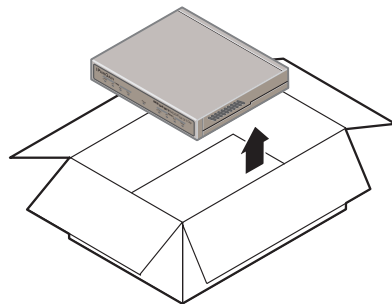

The shipping carton also contains the items described in the following table.

Item	Function
Black cable	Connects the modem Ethernet port to a PC NIC using a straight-through cable.
Yellow cable	Connects the modem Ethernet port to a network hub using a crossover cable.
Gray ADSL cable	Connects the modem ADSL port to an RJ-11 wall jack that has DMT ADSL service.
Gray console cable and adapter	Connects the modem RS-232 port to an ASCII terminal or PC running a terminal emulation program for configuration and management. Cable has RJ-45 connectors. The adapter converts the RJ-45 port to a DB-9.
Universal power supply	Provides primary power to the modem and establishes a safety ground. The Megabit Modem 310F and 320F are available with a variety of power cords. When you order your modem, choose one of the following as the last number in the product PN (Megabit Modem 310F is PN 150-2103-7x and Megabit Modem 320F is PN 150-2102-7x) to indicate which power cord you need: <ul style="list-style-type: none">• 2 does not include a power cord• 3 includes a North American power cord• 4 includes a European power cord.• 5 includes a UK/Ireland power cord
Rubber Feet (4)	Attaches to the base of the modem.

ATTACHING THE FEET

Attach four adhesive-backed rubber feet to the footprint recesses on the bottom of the modem.

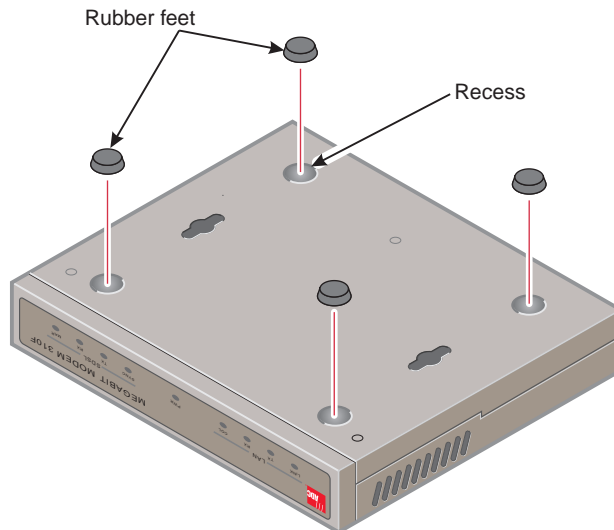

IDENTIFYING THE CONNECTORS

All external connectors are located on the Megabit Modem 310F and 320F rear panel. This section describes the Megabit Modem 310F and 320F rear panel components.

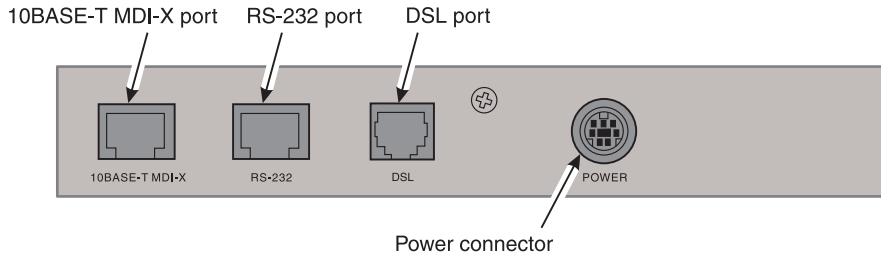

Component	Function
10BASE-T MDI-X port	RJ-45 port used to connect the modem to the 10BASE-T port of a network hub or PC NIC.
RS-232 port	RJ-45 port used to connect an ASCII terminal, or PC running a terminal emulation program, for configuration and management.
DSL port	RJ-11 port used to connect the modem to the ADSL transmission line.
POWER connector	7-pin DIN port that supplies power to the Megabit Modem 310F and 320F.

 **Connect only the power supply provided to the Megabit Modem 310F or 320F. Using any other power supply could permanently damage the unit.**

INSTALLING THE CABLING

Use the provided cables as follows:

- black cable or yellow cable—connect to 10BASE-T port for Ethernet LAN connection
- gray ADSL cable—connect to DSL port for ADSL connection
- power supply—connect to power connector

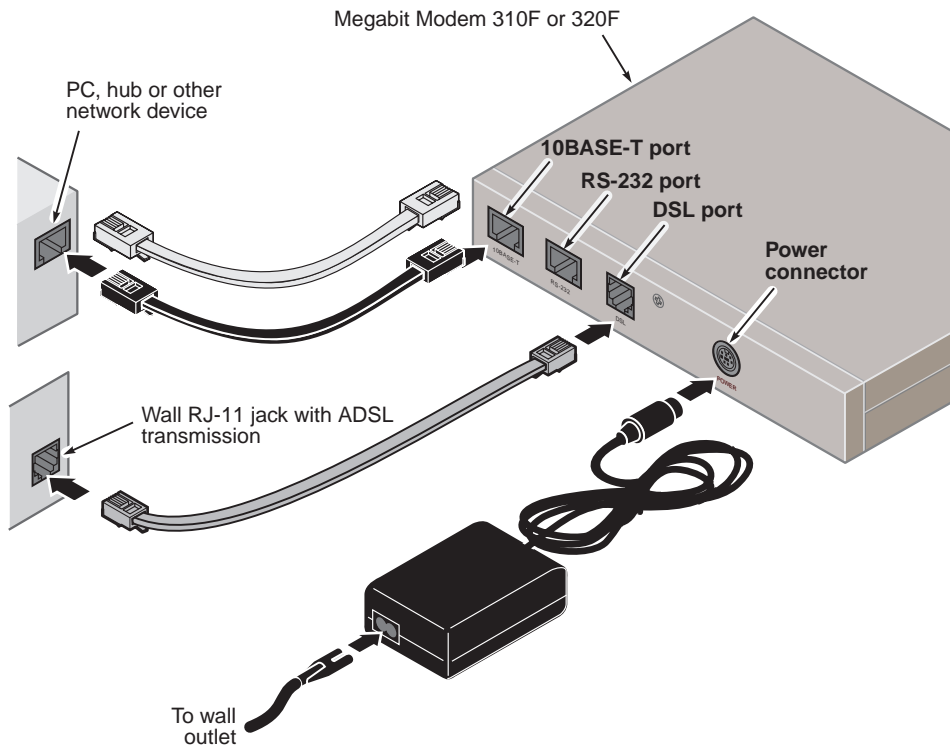

Do not connect any other power supply to the Megabit Modem 310F or 320F. If you use another power supply, you could permanently damage the unit.

See “[Connector Pinouts](#)” on page 53 for ADSL and 10BASE-T connector pinouts.

IDENTIFYING LEDs

The front panels for both the Megabit Modem 310F and 320F contain LEDs that indicate power and data transmission status. The following illustrations describe the front panel LEDs.

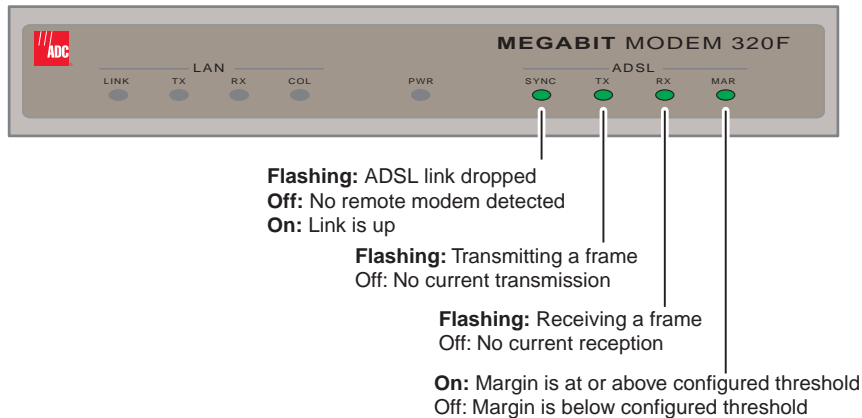
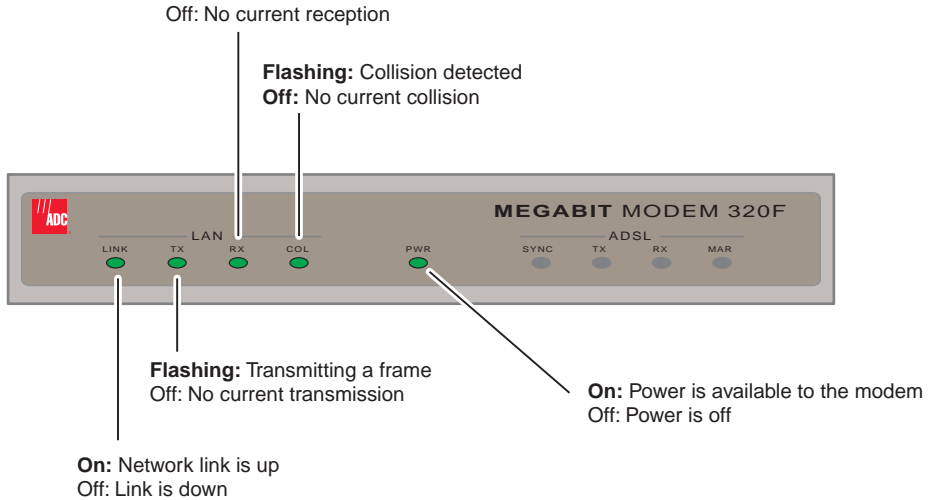

Powering Up and Checking LEDs

Once you have completed the steps described in the previous sections for both the Megabit Modem 310F and 320F, you are ready to power up each modem.

- 1 Plug the Megabit Modem 310F power supply into the facility power and ensure the Power LED is lit solid green.
- 2 Plug the Megabit Modem 320F power supply into the facility power and ensure the Power LED is lit solid green.
- 3 Allow the modems approximately 30 to 60 seconds to synchronize.
- 4 After both modems are powered up, verify the following LED indications on each modem:
 - 10BASE-T LINK LED is solid green (when the Ethernet port is connected)
 - ADSL SYNC LED is solid green when the Megabit Modem 310F synchronizes with the Megabit Modem 320F (the LED flashes green when synchronization is lost between the two modems)
 - ADSL MAR LED is solid green if margin is at or above the configured threshold

If conditions other than those listed above exist, check the cabling. See [“Installing the Cabling” on page 6](#) for instructions.

PREPARING FOR CONFIGURATION AND MANAGEMENT

3

You configure the Megabit Modem 310F and 320F using an ASCII terminal or PC running a terminal emulation program. This chapter provides the set up procedures.

CONNECTING A TERMINAL

Connect the modem to an ASCII terminal or PC running a terminal emulation program:

- 1 Plug the console adapter into the standard 9-pin COM port on the terminal or PC and tighten the captive screws until they are snug. (Skip this step if you are using an ASCII terminal that has an RJ-45 jack.)
- 2 Connect one end of the gray console cable to the adapter or ASCII terminal RJ-45 jack.
- 3 Connect the other end of the gray console cable to the modem RS-232 RJ-45 port.

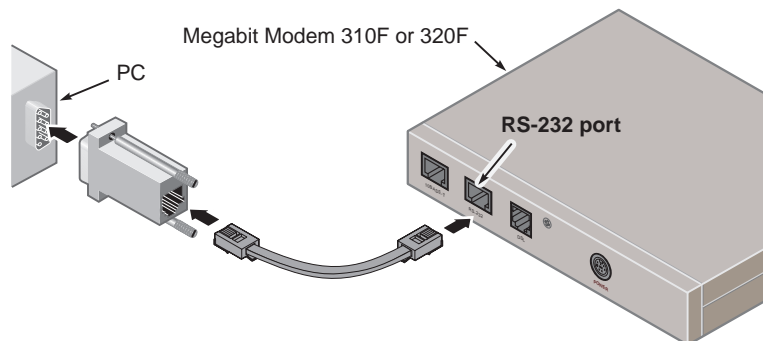

CONFIGURING THE TERMINAL

Whether you are using an ASCII terminal or PC running a terminal emulation program, such as Hyperterminal, you must configure the communication settings as indicated in this section, including designating the connection type and communications port. See your terminal emulation program or operating system documentation for instructions.

- 1 Configure these communication settings:
 - 9600 to 19,200 baud
 - no parity
 - 8 data bits
 - 1 stop bit
 - no flow control
- 2 Set the terminal emulation mode to ANSI.

LOGGING ON AND NAVIGATING THE INTERFACE

Using the management interface, you can manage both the Megabit Modem 310F and 320F. The header on each screen identifies the modem you are currently managing:

- ATU-C is the Megabit Modem 310F.
- ATU-R is the Megabit Modem 320F.

Logging On to the Local Modem



Through the Megabit Modem 310F (ATU-C) System Configuration menu, you can disable the console port on the Megabit Modem 320F (ATU-R).

Use an ASCII terminal or PC running a terminal emulation program to access the management interface.

- 1 Press the **SPACEBAR** several times to activate the autobaud feature and to display the Logon Password screen.

- 2 If you have customized your password, type the password at the password prompt. Otherwise, press **ENTER** which is the factory default password. (See “Changing the Logon Password” on page 17 to customize your password.)

```
07/20/99          PAIRGAIN TECHNOLOGIES          00:47:59
                  ATU-C ADSL MEGABIT MODEM TERMINAL v 1.0

LOGON PASSWORD>
```

The **Main Menu** displays.

```
07/20/99          PAIRGAIN TECHNOLOGIES          03:25:24
                  ATU-C ADSL MEGABIT MODEM TERMINAL v 1.0

                  MAIN MENU

                  1. SYSTEM MENU
                  2. ADSL MENU
                  3. BRIDGE MENU
                  4. REMOTE LOGON

                  Q. LOGOUT

ENTER CHOICE-->
```

Logging On to the Remote Modem

From the Megabit Modem 310F (ATU-C), you can log on to the Megabit Modem 320F (ATU-R) to view system parameters and set configuration options in one of the following ways:

- From the **Main Menu** on the ATU-C, type **4** and the ATU-R Logon screen displays.
- Type **CTRL T** to toggle from any ATU-C screen and the ATU-R Logon screen displays.

ATU-C displays in the header when logged on to the Megabit Modem 310F

```
07/20/99          PAIRGAIN TECHNOLOGIES          00:17:43
                  ATU-C ADSL MEGABIT MODEM TERMINAL v 1.0

                                MAIN MENU

                        1. SYSTEM MENU
                        2. ADSL MENU
                        3. BRIDGE MENU
                        4. REMOTE LOGON

                                Q. LOGOUT

ENTER CHOICE-->
```

ATU-R displays in the header when logged on to the Megabit Modem 320F

```
07/20/99          PAIRGAIN TECHNOLOGIES          00:17:45
                  ATU-R ADSL MEGABIT MODEM TERMINAL v 1.0

LOGON PASSWORD>
```

Once you log on to both the ATU-C and ATU-R modems, type **CTRL T** to toggle between the ATU-C and ATU-R screens to perform configuration or to view status.

When you log on locally to the Megabit Modem 320F, you can view system parameters and set some configuration options for the Megabit Modem 320F only.

Navigating the Interface

The following illustration shows the Megabit Modem 310F and 320F management interface structure. Select a menu option by typing the number that precedes it.

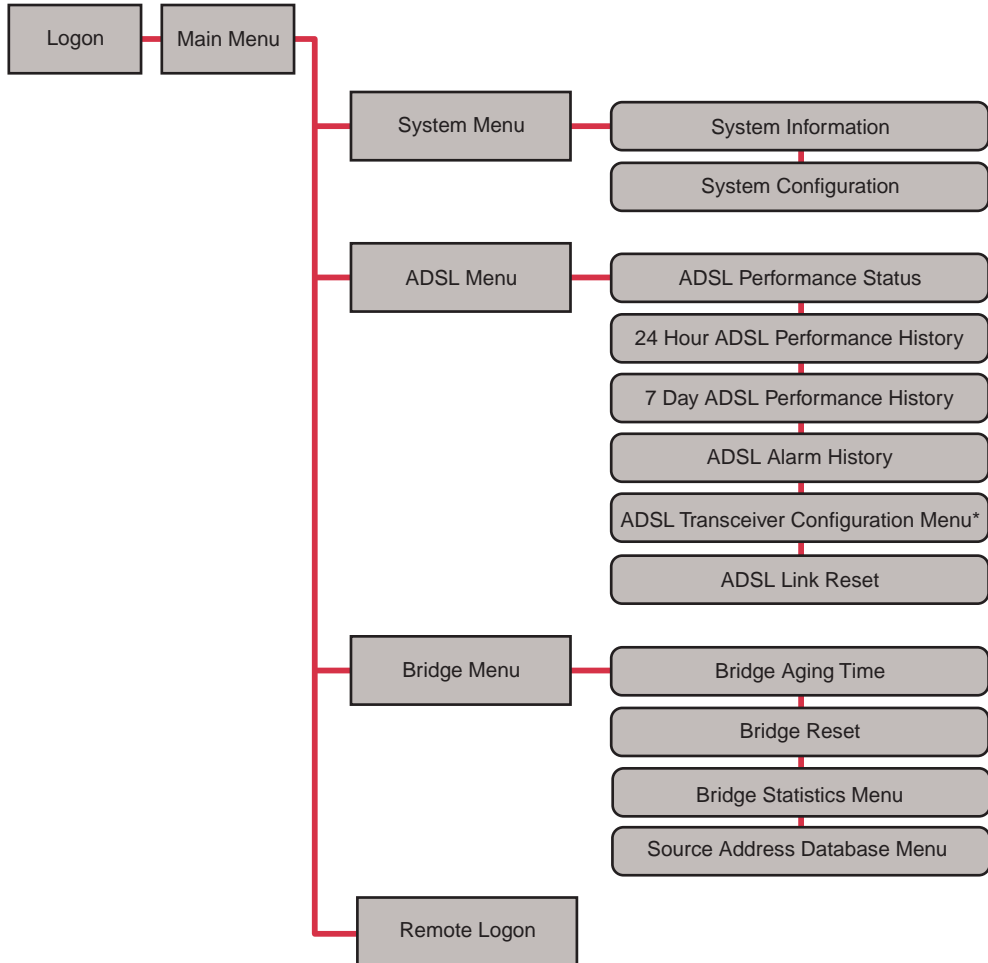

*Read-only field for the Megabit Modem 320F

The following table shows the keyboard functions used to navigate the management interface and to select menu options.

Key	Function
ESC	Restores the selected parameter to the last saved setting. This applies only to parameters for which you type a value but not to parameters for which you toggle to select a value.
M	Opens the Main Menu .
Q	Logs you off the management interface from the Main Menu .
R	Returns to the previous menu.
CTRL R	Refreshes the data on the current screen.
CTRL T	Toggles between ATU-C and ATU-R menus.
C	On performance screens, clears the current performance screen values. On the ADSL Configuration menu, confirms the new configuration and suppresses the confirmation prompts.
N	Selects the next performance screen.
P	Selects the previous performance screen.
U	Restores a previous setting by undoing the last action.

You configure Megabit Modem 310F and 320F parameters in two ways:

- Toggle among predefined settings:
 - 1 Type the number preceding a parameter to select it.
 - 2 Press the **SPACEBAR** to toggle among the available settings until the desired setting displays, then press **ENTER**.
- Type required information:
 - 1 Type the number preceding a parameter to select it. A prompt displays.
 - 2 Type the requested information, following the instructions on the screen, then press **ENTER**.

LOGGING OFF

From the **Main Menu**, type **Q** to log off the management interface.

CONFIGURING THE MODEMS

4

Configure the Megabit Modem 310F and 320F using an ASCII terminal or PC running a terminal emulation program connected to the RS-232 port.

SETTING SYSTEM CONFIGURATIONS

From the **System Configuration** menu, you can set the system time and date, change the password, and reset the modems to factory default values.

- 1 From the **Main Menu** (page 11), type **1** to display the **System Menu**.

```
07/20/99                PAIRGAIN TECHNOLOGIES                03:25:24
                        ATU-C ADSL MEGABIT MODEM TERMINAL v 1.0

                        SYSTEM MENU

                        1. SYSTEM INFORMATION
                        2. SYSTEM CONFIGURATION

                        (M)ain

ENTER CHOICE-->
```

- 2 Type **2** to display the **System Configuration** menu.

```
07/20/99                PAIRGAIN TECHNOLOGIES                03:25:24
                        ATU-C ADSL MEGABIT MODEM TERMINAL v 1.0

                        SYSTEM CONFIGURATION

                        1. CHANGE SYSTEM TIME
                        2. CHANGE SYSTEM DATE
                        3. CHANGE PASSWORD
                        4. FACTORY DEFAULT CONFIGURATION
                        5. ATU-R LOGIN ENABLED

                        (R)eturn  (M)ain

ENTER CHOICE-->
```

Changing the System Time

- 1 From the **System Configuration** menu, type **1** to select **Change System Time**.
The following message displays: Please enter a new time: HH:MM:SS
- 2 At the system prompt, type the new time in specified two-digit 24-hour format, then press **ENTER**.
The new time displays in the upper right corner of the screen.

Changing the System Date

- 1 From the **System Configuration** menu, type **2** to select **Change System Date**.
The following message displays: Please enter a new date: MM:DD:YY
- 2 At the system prompt, type the new month, day and year in the specified two-digit numeric format, then press **ENTER**.
The new date displays in the upper left corner of the screen.

Changing the Logon Password

- 1 From the **System Configuration** menu (page 16), type **3** to select **Change Password**.

The following message displays: Creating user password, press ENTER

- 2 Press **ENTER**.

The following prompt displays: Please enter the new password

- 3 At the system prompt, type the new password, using up to eight characters, then press **ENTER**. (An * displays as you type each character.)

After you press **ENTER**, the following prompt displays: Please retype the new password

- 4 At the system prompt, type the new password again, then press **ENTER**.

The following prompt displays: Password accepted



If you change the default password, write it down and save it in a secure place. If you forget your new password, you will be unable to log on to the modem.

Restoring Factory Default Settings

The following table summarizes the factory default settings. The procedure restores all settings to their factory defaults.

Setting	Factory Default
System	
Ligon Password	ENTER
ATU-R Login (Megabit Modem 320F Craft Port Access)	Enable
ADSL	
Startup Mode	Adaptive Rate
Margin	4 dB
Upstream Data Rate	928 kbps - maximum 64 kbps - minimum
Downstream Data Rate	7040 kbps - maximum 64 kbps - minimum
SNR Margin Threshold	3 dB
ES Threshold	100
Alarm Severity	E, enabled as a minor alarm
Interleave	4 ns
Bridging	
Bridge Aging Time	300

- 1 From the **System Configuration** menu (page 16), type **4** to select **Factory Default Configuration**.

The following message displays: This will reset all the configurations and the ADSL modem. Are you sure? (Y/N)

- 2 Do one of the following:
 - Type **Y** to reset the modem. When you type **Y**, the modem restarts with the factory default settings in effect. The following message displays: NVRAM Updated.
 - Type **N** to discontinue this procedure.



When you select yes to restore the factory default configuration, the modem automatically writes the factory default values to NVRAM and resets the ADSL link between the Megabit Modem 310F and 320F. You are automatically logged off the modem(s) and must log on again.

- If you typed **Y** to restore factory default settings, you must press the **SPACEBAR** several times to display the Logon screen. Then, log on to the modem(s).

Disabling or Enabling the RS-232 Port For the Megabit Modem 320F

You can enable or disable the RS-232 port for the Megabit Modem 320F from the Megabit Modem 310F management interface. The screen option is **ATU-R Login** and the default setting is **Enabled**.



The **ATU-R Login** option displays for the remote modem only when you are logged on to the Megabit Modem 310F (**ATU-C**).

The current status of the Megabit Modem 320F RS-232 port (enable or disable) displays to the right of the **ATU-R Login** option.

- From the **System Configuration** menu, type **5** to select a new **ATU-R Login** option. (When the RS-232 port status is **ENABLED**, it changes to **DISABLED** after typing **5**.)

```

07/20/99                PAIRGAIN TECHNOLOGIES                05:14:24
                        ATU-C ADSL MEGABIT MODEM TERMINAL v 1.0

                        SYSTEM CONFIGURATION

                        1. CHANGE SYSTEM TIME
                        2. CHANGE SYSTEM DATE
                        3. CHANGE PASSWORD
                        4. FACTORY DEFAULT CONFIGURATION
                        5. RT LOGIN  DISABLED

                        (R)eturn (M)ain
                        Press RETURN to confirm, ESC to cancel
ENTER CHOICE-->

```

- Press **ENTER** to confirm the new **ATU-R Login** option for the RS-232 port. The new option displays to the right of **ATU-R Login**.

CONFIGURING ADSL SERVICE



You configure ADSL transceiver service from the Megabit Modem 310F (ATU-C) only. The ADSL Configuration Menu items are read-only from the Megabit Modem 320F (ATU-R). You must reset the ADSL Link to activate ADSL configuration changes (page 26).

This section describes how to configure ADSL data transmission parameters.

- 1 From the **Main Menu** (page 11), type **2** to display the **ADSL Menu**.

```

07/20/99                PAIRGAIN TECHNOLOGIES                03:25:24
                        ATU-C ADSL MEGABIT MODEM TERMINAL v 1.0

                        ADSL MENU

                        1. ADSL PERFORMANCE STATUS
                        2. 24 HOUR ADSL PERFORMANCE HISTORY
                        3. 7 DAY ADSL PERFORMANCE HISTORY
                        4. ADSL ALARM HISTORY
                        5. ADSL CONFIGURATION MENU
                        6. ADSL LINK RESET

                        (M)ain

ENTER CHOICE-->

```

- 2 From the **ADSL Menu**, type **5** to display the **ADSL Configuration Menu**.

```

07/20/99                PAIRGAIN TECHNOLOGIES                00:26:09
                        ATU-C ADSL MEGABIT MODEM TERMINAL v 1.0

                        ADSL CONFIGURATION MENU

                        1. STARTUP OPTION                    ADAPTIVE RATE
                        2. (MAX) UP DATA RATE                928 ( 64 - 928 Kbps)
                        3. (MAX) DOWN DATA RATE              7040 ( 64 - 7040 Kbps)
                        4. (MIN) UP DATA RATE                64 ( 64 - 928 Kbps)
                        5. (MIN) DOWN DATA RATE              64 ( 64 - 7040 Kbps)

                        6. STARTUP SNR MARGIN                 4dB
                        7. MARGIN THRESHOLD                  3
                        8. ES THRESHOLD                       100
                        9. ALARM CONFIGURATION                LOF=E MAR=E ES=E SES=E LOS=E SELF=E
                        A. UP INTERLEAVE OPTION                4 msec
                        B. DOWN INTERLEAVE OPTION              4 msec

                        (U)ndo (R)eturn (M)ain

ENTER CHOICE-->

```

Configuring the Startup Settings



You can configure these settings only from the Megabit Modem 310F for both the Megabit Modem 310F and 320F. The fields are **Read Only Parameters** when you access them through the management interface for the Megabit Modem 320F.

You configure the Startup Option and Startup SNR Margin to establish how the modem comes up to achieve a transmission rate after a reset (see [page 26](#) for resetting the modem).

Select the Startup Option

- 1 From the **ADSL Configuration Menu** ([page 20](#)), type **1** to select Startup Option.
- 2 Press the **SPACEBAR** to sequence to the **Startup Option** you want, then press **ENTER**.

The startup option determines how an ADSL transmission rate is established when the modem is reset. The default is Adaptive Rate. The following table describes the available options.

Startup Option	Description
Adaptive Rate	The modem comes up at the highest possible data rate based on the configured startup margin and line conditions. Adaptive Rate is the default.
Fixed Rate	At startup, the system attempts only the rates you configure in “Configuring Data Rates” on page 22 , which include maximum upstream and downstream data rates with a margin greater than or equal to the configured margin. If the data rates cannot be obtained, the system continues to attempt the data rate. If it does not achieve the data rate, the modems will not sync.

Select the Startup SNR Margin

- 1 From the **ADSL Configuration Menu** ([page 20](#)), type **6** to select **Startup SNR Margin**.
- 2 Press the **SPACEBAR** to sequence to the **Startup SNR Margin** value you want, then press **ENTER**.

The Startup SNR Margin is the margin that the modem must achieve to come up. The available values range from 0 to 15 dB. The default is 4 dB.

Configuring Data Rates



You can configure the data rate only from the Megabit Modem 310F for both the Megabit Modem 310F and 320F. The data rate fields are Read Only Parameters when you access them from the Megabit Modem 320F (ATU-R).

You configure the minimum and maximum data rates for both upstream and downstream traffic. The maximum data rates determine the rate the modem must achieve to come up when the startup option is set to Fixed Rate (see [page 21](#)).

1 Configure the upstream data rates (transmission toward the Megabit Modem 310F):

- a** From the **ADSL Configuration Menu** ([page 20](#)), type **2** to select **(Max) Up Data Rate**.

The following message displays: Enter valid input

- b** Type a maximum upstream data rate, in kbps, then press **ENTER**.

The valid data rate values are increments of 32 between 64 and 928 kbps. If you enter a value that is not an increment of 32, the modem automatically adjusts it to the closest increment of 32. The default is 928 kbps.

- c** Type **4** to select **(Min) Up Data Rate**.

The following message displays: Enter valid input

- d** Type a minimum upstream data rate, in kbps, then press **ENTER**.

The valid data rate values are increments of 32 between 64 and 928 kbps. If you enter a value that is not an increment of 32, the modem automatically adjusts it to the closest increment of 32. The default is 64 kbps.

2 Configure the downstream data rates (transmission toward the Megabit Modem 320F):

- a** From the **ADSL Configuration Menu** ([page 20](#)), type **3** to select **(Max) Down Data Rate**.

The following message displays: Enter valid input

- b** Type a maximum downstream data rate, in kbps, then press **ENTER**.

The valid data rate values are increments of 32 between 64 kbps and 7040 kbps. If you enter a value that is not an increment of 32, the modem automatically adjusts it to the closest increment of 32. The default is 7040 kbps.

- c Type **5** to select **(Min) Down Data Rate**.

The following message displays: Enter valid input

- d Type a maximum downstream data rate, in kbps, then press **ENTER**.

The valid data rate values are increments of 32 between 64 kbps and 7040 kbps. If you enter a value that is not an increment of 32, the modem automatically adjusts it to the closest increment of 32. The default is 64 kbps.

Configuring the SNR Margin Threshold

The margin threshold determines the SNR margin value below which an SNR margin alarm occurs and the MAR LED on the modem front panel turns off.

- 1 From the **ADSL Configuration Menu** (page 20), type **7** to select Margin Threshold.

The following message displays: Enter Valid Input

- 2 Type an SNR dB value between 0 and 15, then press **ENTER**.

The default value is 3 dB.

Configuring the ES Threshold

The ES (Errored Seconds) Threshold is the number of acceptable seconds in a 15-minute interval during which errors occur. If the number of errored seconds in the 15-minute interval exceeds this value, an ES alarm occurs.

- 1 From the **ADSL Configuration Menu** (page 20), type **8** to select **ES Threshold**.

The following message displays: Enter valid input

- 2 Type an ES threshold value between 0 and 255, then press **ENTER**.

The default value is 100.

Configuring Alarms

You can configure the severity of each modem alarm, or disable alarms.

- 1 From the **ADSL Configuration Menu** (page 20), type **9** to select **Alarm Configuration**.
- 2 Type **N** to move to the next alarm type until you select the one you want to configure.

The following table identifies the available alarm types.

Alarm Type	Description
LOF	Loss of Frame
MAR	Margin
ES	Errored Seconds
SES	Severely Errored Seconds
LOS	Loss of Signal
SELF	Self test failed

- 3 Press the **SPACEBAR** to toggle to the setting you want for the alarm, then press **ENTER**.

The following table describes the available alarm settings. The default for each alarm is E.

Setting	Description
E	Enables the alarm as a minor alarm.
M	Enables the alarm as a major alarm.
D	Disables the alarm.

Configuring the Interleave Options



It is important to note that an increase in impulse noise immunity causes an increase in delay.

Use the interleave option to increase impulse noise immunity. The delay is in milliseconds for both the Up and Down Interleave Options (upstream and downstream traffic).

1 From the **ADSL Configuration Menu** (page 20), type **A** to select **Up Interleave Option**.

2 Press the **SPACEBAR** to toggle to the interleave value you want, then press **ENTER**.

The available options are 0, 2, 4, 8 and 16 msec. The recommended interleave delay is 4 msec, to achieve maximum transmission rates with adequate noise immunity. The default is 4.

3 Type **B** to select **Down Interleave Option**.

4 Press the **SPACEBAR** to toggle to the interleave value you want, then press **ENTER**.

The available options are 0, 2, 4, 8 and 16 msec. The recommended interleave delay is 4 msec, to achieve minimum latency with adequate noise immunity. The default is 4.

Saving ADSL Configuration Changes

After you make changes to ADSL configuration from the **ADSL Configuration Menu** (page 20), you must either accept or not accept these changes before you can return to **ADSL Menu** (page 20).

1 When you finish making changes to ADSL configuration, type **M** or **R** to exit the **ADSL Menu**.

The following prompt displays: Save current settings (Y/N)?

2 Type **Y** to save the changes you made or type **N** to not save the changes you made.

You return to the **ADSL Menu**.

Resetting the ADSL Link

After you make any ADSL configuration changes, you must reset the ADSL link to activate the new configuration and reestablish the ADSL link.

- 1 From the **ADSL Menu** (page 20), type **6** to reset the ADSL link.

The following prompt displays: This will bring down the ADSL link. Are you sure (Y/N)?



When you select yes, the modem automatically resets the ADSL link between the Megabit Modem 310F and 320F. You are automatically logged off the modem(s) and must log on again.

- 2 Do one of the following:

- Type **Y** to reset the ADSL link.

The following message displays: ADSL link reset

- Type **N** if you do not want to reset the modem. (If you do not reset the modem, ADSL configuration changes you made are not activated.)

CONFIGURING BRIDGE PARAMETERS

Configure the Ethernet bridging parameters. The LAN mode for the Megabit Modem 310F and 320F is half duplex.

- 1 On the **Main Menu** (page 11), type **3** to display the **Bridge Menu**.

```

09/09/99                PAIRGAIN TECHNOLOGIES                03:36:55
                        ATU-C ADSL MEGABIT MODEM TERMINAL v 1.0

                        BRIDGE MENU

                        LAN LINK STATUS                        UP

1. BRIDGE AGING TIME                300 SECONDS
2. BRIDGE RESET
3. BRIDGE STATISTICS MENU
4. SOURCE ADDRESS DATABASE MENU

                        (M)ain

ENTER CHOICE-->

```

Configuring Bridge Aging Time

The Bridge Aging Time determines the interval at which the modem checks the bridging table for unused addresses and marks those addresses as invalid. The default is 300 seconds.

- 1 Type **2** to select **Bridge Aging Time**.
- 2 Type the value in seconds (valid range is from 1 to 511) that you want, then press **ENTER**.

Configuring the Source Address Database

The source address database can contain up to 8,192 entries. Addresses can be entered either automatically through address learning on the LAN port, or manually. Each address is mapped to a 10-bit key, which is used to group the addresses into 1,024 separate buckets containing up to eight addresses in each bucket. This reduces the search time required to locate an address in the address table by requiring the processor to search only one bucket, or a maximum of eight addresses.

- 1 From the Bridge Menu, type **4** to display the **Source Address Database Menu**.

```

08/12/99                PAIRGAIN TECHNOLOGIES                03:45:44
                        ATU-C ADSL MEGABIT MODEM TERMINAL v 1.0

                        SOURCE ADDRESS DATABASE MENU

1. READ ALL VALID MAC ENTRIES    4. CREATE STATIC MAC ADDRESS ENTRY
2. READ ENTRY BY MAC ADDRESS    5. DELETE STATIC MAC ADDRESS ENTRY
3. READ BUCKET                  6. DISPLAY ALL STATIC MAC ADDRESS ENTRIES

BUCKET NUMBER = 0          TYPE  VALID  MAC ADDRESS
-----
--      INV  00:00:00:00:00:00
--      INV  00:00:00:00:00:00
--      INV  00:00:00:00:00:00
--      INV  00:00:00:00:00:00
--      INV  00:00:00:00:00:00
--      INV  00:00:00:00:00:00
--      INV  00:00:00:00:00:00
--      INV  00:00:00:00:00:00

(R)eturn (M)ain (N)ext (P)revious (U)pdate

ENTER CHOICE-->

```

The following table describes the data displayed on the **Source Address Database Menu**.

Column	Description
TYPE	Indicates the method by which the entry was added to the table. The options are:
DYN	Dynamic is automatically learned by the LAN port.
STAT	Static is entered manually.
---	Indicates that the table row is empty.
VALID	VAL - Indicates that the entry is valid and being used. INV - Indicates that the entry is not being used.
MAC ADDRESS	The MAC address associated with the parameters contained in that row of the bridging table.

2 To view all valid Bridge Address Table entries by MAC address:

a Type **1** to select **Read All Valid MAC Entries**.

The message displays: Searching Database

Eight entries, that result from the search, display. The bucket number indicates the last bucket searched.

The message displays: Press C to Continue Searching

b Type **C** to display the next eight entries of the search.

When no more entries are found in the database, the message displays:
Search Finished

3 To view a Bridge Address Table entry by MAC address:

a Type **2** to select **Read Entry by MAC Address**.

The message displays: Please enter MAC Address
(aa:bb:cc:dd:ee:ff)

b Type the MAC address, then press **ENTER**.

4 To view all the entries in a specific bucket:

a Type **3** to select **Read Bucket**.

The message displays: Please enter bucket number

b Type the desired bucket number, then press **ENTER**.

- 5 To add a static MAC address to the Bridge Address Table:
 - a Type **4** to select **Create Static MAC Address Entry**.
The message displays: Please enter MAC Address
(aa:bb:cc:dd:ee:ff)
 - b Type the MAC address, then press **ENTER**.
 - c Type **U** to update the data in the current bucket, or type **6** to Display All Static MAC Address Entries.
- 6 To delete a static MAC address from the Bridge Address Table:
 - a Type **5** to select **Delete Static MAC Address Entry**.
The message displays: Please enter MAC Address
(aa:bb:cc:dd:ee:ff)
 - b Type the MAC address, then press **ENTER**.
The MAC address you just deleted displays:
MAC address = aa:bb:cc:dd:ee:ff
 - c Type **U** to update the data in the current bucket, or type **6** to Display All Static MAC Address Entries.
- 7 To view all Bridge Address Table static MAC entries:
 - a Type **6** to select **Display All Static MAC Entries**.
The message displays: Searching Database
Eight entries, that result from the search, display. The bucket number indicates the last bucket searched.
The message displays: Press C to Continue Searching
 - b Type **C** to display the next eight entries of the search.
When no more entries are found in the database, the message displays:
Search Finished

Resetting the Bridge

Use the **Bridge Reset** option to reset the modem bridge function. Under rare conditions, the bridge function may stop forwarding frames. If the DSL link is up and no errored seconds are accumulating, but Ethernet data is not passing through the modem, a bridge reset on either the ATU-C or ATU-R unit may resolve the problem.

MONITORING CIRCUIT STATUS AND DISPLAYING SYSTEM INFORMATION

5

Monitor circuit status for the Megabit Modem 310F and 320F using an ASCII terminal or PC running a terminal emulation program, connected to the RS-232 port.

MONITORING ADSL STATUS

From the **Main Menu** (page 11), type **2** to display the **ADSL Menu**. From this menu, you can select items 1 through 4 to provide status on the ADSL link, as described in the following sections.

```
07/20/99          PAIRGAIN TECHNOLOGIES          03:25:24
                  ATU-R ADSL MEGABIT MODEM TERMINAL v 1.0

                  ADSL MENU

                  1. ADSL PERFORMANCE STATUS
                  2. 24 HOUR ADSL PERFORMANCE HISTORY
                  3. 7 DAY ADSL PERFORMANCE HISTORY
                  4. ADSL ALARM HISTORY
                  5. ADSL CONFIGURATION MENU
                  6. ADSL LINK RESET

                  (M)ain

ENTER CHOICE-->
```

Monitoring ADSL Performance Status

The **ADSL Performance Status** screen is updated every second and provides a summary of the current ADSL status, including alarms, for both upstream and downstream traffic. The SNR (signal-to-noise ratio) Margin row displays both the current SNR margins and the minimum SNR margins for the current 24-hour data collection period.

On the **ADSL Menu** (page 31), type **1** to display the **ADSL Performance Status** screen.

```
07/20/99                PAIRGAIN TECHNOLOGIES                03:25:24
                        ATU-R ADSL MEGABIT MODEM TERMINAL v 1.0

                        ADSL PERFORMANCE STATUS

DOWN ALARMS:           NONE
UP ALARMS:             NONE
SYSTEM STATE:          DATA

                        DOWNSTREAM                UPSTREAM
                        -----                -----
                        cur/min                  cur/min

SNR MARGIN (dB):       16.0/15.1                4.1/3.9
LINE ATTN (dB):        4.60                    0.9
24 HOUR ES:            0                      0
24 HOUR UAS:           0                      0
DATA RATE (kbps):      7040                    800

                        (C)lear    (R)eturn    (M)ain

ENTER CHOICE-->
```

Type **C** to clear the ADSL performance and alarm counters in both the Megabit Modem 310F and 320F. See the table on [page 33](#) for a definition of each status field.

The following table describes the data displayed on the **ADSL Performance Status** screen.

Field	Meaning
Down Alarms	Identifies the current downstream alarms (toward the Megabit Modem 320F). Options: <ul style="list-style-type: none"> • LOF - Loss of Frame • LOS - Loss of Signal • MAR - Margin • ES - Errored Seconds • SES - Severely Errored Seconds • SELF - Self Test Failed • NONE - No current alarms
Up Alarms	Identifies the current upstream alarms (transmission toward the Megabit Modem 310F).
System State	Identifies the state of the ADSL system: <ul style="list-style-type: none"> • ACK - Acknowledge during handshake. • TRAINING - Modem is currently training. • CHANA - Channel analysis is in process. • EXCH - Exchange final handshaking messages. • DATA - Link is up and data can be transferred.
SNR Margin (dB)	Identifies the current (cur) and minimum (min) margin values for the ADSL loop for the current 24-hour period. See “Reach, Data Rate, SNR Margin, and Noise Environment” on page 48 for information on SNR margin and BER.
Line Attn (dB)	Indicates the line attenuation for the upstream and downstream ADSL channels. Line attenuation is the decrease in amplitude of the signal between transmission and receipt.
24 Hour ES	Indicates the total number of errored seconds that were detected on the ADSL link during the current 24-hour period.
24 Hour UAS	Indicates the total number of unavailable seconds (UAS) that were detected on the ADSL link during the current 24-hour period. UAS indicate the amount of time that the lines were unavailable for transmission since the modem was powered up or cleared.
Data Rate (kbps)	Identifies the current rates at which data is being transmitted.

Monitoring 24 Hour ADSL Performance History

The **24 Hour ADSL Performance History** report consists of eight screens. Each screen displays three hours of data, in 15-minute increments. Together, the eight screens provide a summary of the 24-hour performance history.

From the **ADSL Menu** (page 31), type **2** to open the **24 Hour ADSL Performance History** screen.

```

07/20/99                PAIRGAIN TECHNOLOGIES                03:25:24
                        ATU-R ADSL MEGABIT MODEM TERMINAL v 1.0

                        24 HOUR ADSL PERFORMANCE HISTORY
                        (errored seconds/unavailable seconds/snr)

                        DOWNSTREAM                UPSTREAM
02:45  000/000/15.5                000/000/3.9
02:30  000/000/16.0                000/000/3.9
02:30  000/000/ NA                000/000/ NA
02:30  000/000/ NA                000/000/ NA
02:45  000/000/ NA                000/000/ NA
02:30  000/000/ NA                000/000/ NA
02:30  000/000/ NA                000/000/ NA
02:30  000/000/ NA                000/000/ NA
02:30  000/000/ NA                000/000/ NA
02:45  000/000/ NA                000/000/ NA
02:30  000/000/ NA                000/000/ NA
02:30  000/000/ NA                000/000/ NA
02:30  000/000/ NA                000/000/ NA

                        (C)lear (P)revious (N)ext (R)eturn (M)ain

ENTER CHOICE-->

```

To clear all ES and UAS counts, including the equivalent counts in the remote unit, type **C**. The minimum SNR for the period is reset to the current SNR.



The 24 Hour ADSL Performance History data is lost when the modem is turned off.

Monitoring 7 Day ADSL Performance History

The **7 Day ADSL Performance History** menu displays the ES and UAS counts, and the minimum SNR margins for the current day and the previous six days. Each day begins at 12 A.M. midnight, therefore the current day count is not necessarily equal to the count for the past 24 hours.

From the **ADSL Menu** (page 31), type **3** to open the **7 Day ADSL Performance History** screen.

```

07/20/99                PAIRGAIN TECHNOLOGIES                03:25:24
                        ATU-R ADSL MEGABIT MODEM TERMINAL v 1.0

                        7 DAY ADSL PERFORMANCE HISTORY
                        (errored seconds/unavailable seconds/snr)

                        DOWNSTREAM                UPSTREAM
01/01/99                00000/00000/ 20.4        00000/00000/  4.1
12/31/98                00000/00000/   NA         00000/00000/   NA
12/30/98                00000/00000/   NA         00000/00000/   NA
12/29/98                00000/00000/   NA         00000/00000/   NA
12/28/98                00000/00000/   NA         00000/00000/   NA
12/27/98                00000/00000/   NA         00000/00000/   NA
12/26/98                00000/00000/   NA         00000/00000/   NA

                        (C)lear (R)eturn (M)ain

ENTER CHOICE-->

```

To clear all ES and UAS counts, including the equivalent counts in the remote unit, type **C**. The minimum SNR for the period is reset to the current SNR.



The 7 Day ADSL Performance History data is lost when the modem is turned off.

Monitoring ADSL Alarm History

The **ADSL Alarm History** screen displays the current status and first and last occurrence of each ADSL alarm type.

From the **ADSL Menu** (page 31), type **4** on the ADSL Menu to open the **ADSL Alarm History** screen.

```
07/20/99                PAIRGAIN TECHNOLOGIES                03:25:24
                        ATU-R ADSL MEGABIT MODEM TERMINAL v 1.0
                        ADSL ALARM HISTORY

Type                    First                    Last                    Curr                    Time(s)
LOF, DOWN              OK
LOF, UP                OK
MARGIN, DOWN          OK
MARGIN, UP            OK
ES, DOWN              OK
ES, UP                OK
SES, DOWN             OK
SES, UP              OK
LOS, DOWN            OK
LOS, UP             OK

SELFTTEST              OK
LAST CLEARED 07/20/99-02:06:14

                        (C)lear (R)eturn (M)ain

ENTER CHOICE>
```

Type **C** to clear the first and last date/time stamps.



The Alarm History data is lost when the Megabit Modem 310F is turned off.

The following table describes the information displayed on the **ADSL Alarm History** screen.

Name	Description
Type	Identifies local, remote, and ADSL link alarms: <ul style="list-style-type: none">• LOF: Loss of frame failure• MARGIN: Low SNR margin alarm• ES: Errored seconds• SES: Severely errored seconds• LOS: Loss of signal• SELFTEST: Whether the self test was successful or not.• LAST CLEARED: The time the screen was last cleared.
First	Lists the first time an alarm is detected.
Last	Lists the last time an alarm was detected.
Current	Identifies the current status of the alarm.
Time(s)	Lists the time in seconds that any alarm occurred.

MONITORING ETHERNET BRIDGE STATISTICS

The Megabit Modem 310F and 320F provide real-time, non-disruptive monitoring of system performance. The display is updated every second.

- 1 From the **Main Menu** (page 11), type **2** to open the **Bridge Menu**.

```
08/12/99                PAIRGAIN TECHNOLOGIES                00:15:45
                        ATU-C ADSL MEGABIT MODEM TERMINAL v 1.0

                        BRIDGE MENU

                        LAN LINK STATUS                        UP

1. BRIDGE AGING TIME                300 SECONDS
2. BRIDGE RESET
3. BRIDGE STATISTICS MENU
4. SOURCE ADDRESS DATABASE MENU

                        (M)ain

ENTER CHOICE-->
```

- 2 From the **Bridge Menu**, type **3** to open the **Bridge Statistics Menu**.

```
08/12/99                                PAIRGAIN TECHNOLOGIES                                00:02:32
                                         ATU-C ADSL MEGABIT MODEM TERMINAL v 1.0

                                         BRIDGE STATISTICS MENU

LAN PORT                                WAN PORT                                BRIDGE
RX BYTES                                252436 RX BYTES                                0 ENTRIES LEARNED                                20
RX FRAMES                                1476 RX FRAMES                                0 ENTRIES NOT LEARNED                                0
RX MCASTS                                922 RX DISCARDS                                0 LAN FILTERED FRAMES                                99
RX DISCARDS                                1186 RX ERRORS                                0
RX ERRORS                                0 RX BIG                                0
RX SMALL                                0
RX BIG                                0

TX BYTES                                0 TX BYTES                                0
TX FRAMES                                0 TX FRAMES                                0
TX MCASTS                                0
TX EX COLS                                0

                                         (R)eturn (M)ain (C)lear

ENTER CHOICE-->
```

The following table describes the data displayed on the **Bridge Statistics Menu**.

Field	Definition
Rx Bytes	The number of bytes received.
Rx Frames	The number of frames received.
Rx MCASTS	The number of multicast frames received.
Rx Errors	The number of errored frames received.
Rx Runts	The number of frames received that are smaller than the Ethernet minimum of 64 bytes.
Rx MTU Ex	The number of frames received that exceed the Maximum Transmit Unit size of 1518 bytes.
Tx Bytes	The number of bytes transmitted.
Tx Frames	The number of frames transmitted.
Tx MCASTS	The number of multicast frames transmitted.
Tx Ex Cols	The number of excessive collision events that have occurred - frame dropped because of 16 consecutive collisions.
TX Discards	The number of frames dropped due to a buffer overflow.
Entries Learned	The number of entries learned on the LAN port and added to the bridging table.
Entries Not Learned	The number of entries in the bridging table that were not learned because the table was full.
LAN Filtered Frames	The number of frames filtered on the LAN port by the bridging process.

DISPLAYING SYSTEM INFORMATION

The **System Information** screen provides general product information, such as hardware serial numbers and software revision numbers.

- 1 From the **Main Menu** (page 11), type **1** to open the **System Menu**.
- 2 From the **System Menu**, type **1** to display the **System Information** screen. This screen provides the information described in the table below.

```

07/20/99                PAIRGAIN TECHNOLOGIES                04:08:13
                        ATU-C ADSL MEGABIT MODEM TERMINAL v 1.0

                        SYSTEM INFORMATION

MODEM                   PRODUCT NUM           ATU-C           ATU-R
                        150-2103-01          150-2102-01

                        SOFTWARE REV          1.0            1.0
                        PROM CHECKSUM        6C01           BC9D

HISTORY                 DAYS IN OPERATION   125            125

                        (R)eturn (M)ain

ENTER CHOICE-->

```

Information	Description
Modem	
Product Number	The ADC 150 part number for the modem.
Software Rev	The version number of the software that is installed on the modem.
PROM Checksum	The number that is used to verify that the compiled code is valid.
History	
Day in Operation	The number of days that the modem has been in operation. The number of days is stored in non-volatile memory and retained even when the modem is power off and on again. The day increments when the time increases past 23:59:59 - 00:00:00.

ABOUT THE TECHNOLOGY



This appendix provides more information about the bridging and ADSL transmission features of the Megabit Modem 310F and 320F.

MAC LAYER BRIDGING

A bridge moves information across an internetwork from a source to a destination at the link layer (of an OSI reference model). The information is forwarded or filtered based on its Media Access Control (MAC) address.

The Megabit Modem 310F and 320F provide transparent Ethernet MAC level bridging which includes learning, forwarding, filtering, and hashing/buffer management.

Forwarding performance is at full DMT rate and filtering performance is at full Ethernet rate of 14 kpps for 64-byte frames (minimum size).

Neither the Megabit Modem 310F nor 320F support the Spanning Tree protocol. Therefore, the modems cannot be used to provide link redundancy to a LAN segment.

DATA ENCAPSULATION

Data transmitted over the ADSL link comprises HDLC encapsulated Ethernet MAC frames as shown in the figure below.

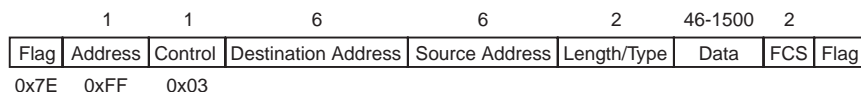

One or more flag patterns (0x7E) occur between frames to indicate the frame boundaries. Zero bit insertion is used for data transparency. This means that a zero is inserted after every occurrence of five consecutive ones (1s) in the data field. This prevents a flag pattern from occurring in the data.

ETHERNET FRAME RATES

The following sections show Ethernet maximum frame transmission rates, dependent on the additional bit and bit stuffing set for the xDSL transmission.

Minimum xDSL Bit Stuffing, One Additional Bit

Ethernet	
Data rate	10 Mbps
Preamble	8 bytes
CRC	4 bytes
Interframe gap	9.60E-06 s

xDSL	
Flags	1 byte
FCS	2 bytes
Protocol	2 bytes
Overhead/Frame	5 bytes
Additional bits	1 bit
Bit stuffing	min (min/max)

The values in the table below show the frames per second for the maximum xDSL rate.

Frame Size (data:sa:lt:data:crc) [bytes]	xDSL Data Rate							
	7040 kbps	6400 kbps	3200 kbps	1536 kbps	896 kbps	768 kbps	384 kbps	64 kbps
64	13,512.5	12,284.1	6,142.0	2,948.2	1,719.8	1,474.1	737.0	122.8
128	6,815.1	6,195.5	3,097.8	1,486.9	867.4	743.5	371.7	62.0
512	1,715.0	1,559.1	779.5	374.2	218.3	187.1	93.5	15.6
1024	858.4	780.4	390.2	187.3	109.3	93.6	46.8	7.8
1518	579.3	526.6	263.3	126.4	73.7	63.2	31.6	5.3

The values in the table below show the minimum xDSL transmission time in milliseconds (ms).

Frame Size (data:sa:lt:data:crc) [bytes]	xDSL Data Rate							
	7040 kbps	6400 kbps	3200 kbps	1536 kbps	896 kbps	768 kbps	384 kbps	64 kbps
64	0.074	0.081	0.163	0.339	0.581	0.678	1.357	8.141
128	0.147	0.161	0.323	0.673	1.153	1.345	2.690	16.141
512	0.583	0.641	1.283	2.673	4.581	5.345	10.690	64.141
1024	1.165	1.281	2.563	5.339	9.153	10.678	21.357	128.141
1518	1.726	1.899	3.798	7.912	13.564	15.824	31.648	189.891

Maximum xDSL Bit Stuffing, Zero Additional Bits

Ethernet	
Data rate	10 Mbps
Preamble	8 bytes
CRC	4 bytes
Interframe gap	9.60E-06 s

xDSL	
Flags	1 byte
FCS	2 bytes
Protocol	2 bytes
Overhead/Frame	5 bytes
Additional bits	0 bits
Bit stuffing	max (min/max)

The values in the table below show the frames per second for the maximum xDSL rate.

Frame Size (da:sa:lt:data:crc) [bytes]	xDSL Data Rate							
	7040 kbps	6400 kbps	3200 kbps	1536 kbps	896 kbps	768 kbps	384 kbps	64 kbps
64	11,318.3	10,289.4	5,144.7	2,469.5	1,440.5	1,234.7	617.4	102.9
128	5,695.8	5,178.0	2,589.0	1,242.7	724.9	621.4	310.7	51.8
512	1,430.0	1,300.0	650.0	312.0	182.0	156.0	78.0	13.0
1024	715.6	650.5	325.3	156.1	91.1	78.1	39.0	6.5
1518	482.9	439.0	219.5	105.3	61.5	52.7	26.3	4.4

The values in the table below show the minimum xDSL transmission time in milliseconds (ms).

Frame Size (data:sa:lt:data:crc) [bytes]	xDSL Data Rate							
	7040 kbps	6400 kbps	3200 kbps	1536 kbps	896 kbps	768 kbps	384 kbps	64 kbps
64	0.088	0.097	0.194	0.405	0.694	0.810	1.620	9.719
128	0.176	0.193	0.386	0.805	1.379	1.609	3.219	19.313
512	0.699	0.769	1.538	3.205	5.494	6.410	12.820	76.922
1024	1.397	1.537	3.074	6.405	10.980	12.810	25.620	153.719
1518	2.071	2.278	4.556	9.492	16.272	18.984	37.969	227.813

RATE ADAPTIVE TRANSMISSION

The following definitions are useful for understanding the operation of the Megabit Modem:

- Bit Error Rate (BER) is the ratio of received bits that are in error relative to the total number of bits received, measured over time. For example, 10^{-7} BER means that on average one error occurs per 10^7 bits received.
- Signal to Noise Ratio (SNR) is the ratio (typically expressed in dB) of the received signal power to the received noise power. It is a measure of the quality of the transmission.
- Margin (SNR margin) is the amount of degradation in SNR that the system can tolerate under the current conditions and still achieve a 10^{-7} BER. A margin of 6 dB, for example, would mean that the SNR can degrade by 6 dB and still provide a performance of 10^{-7} BER. The Megabit Modem 310F and 320F have a margin configuration option that defaults to 4 dB, but may be set anywhere between 0 to 15 dB.
- Reach is the longest loop length that the system can support with a given margin and a BER of less than 10^{-7} at the given data rate.

Rate Adaptation

With ADC's rate adaptive technology, the Megabit Modem 310F and 320F can automatically adjust to the fastest speed possible, given the transmission distance and line conditions. Or, you can set the modem to a specific rate. The available data rates are:

- downstream rates: 64 kbps to 7040 kbps, in increments of 32 kbps
- upstream rates: 64 kbps to 928 kbps, in increments of 32 kbps

The Megabit Modem 310F and 320F can be set to any one of two modes that determine how the data rate is selected. It is important to note that rate adaptation occurs only during startup. The Megabit Modem 310F and 320F will not change the data rate while the link is up. The two startup modes are:

Startup Option	Description
Adaptive Rate	The modem comes up at the highest possible data rate given the configured startup margin and line conditions.
Fixed Data Rate	At startup, the system attempts only the configured maximum upstream and downstream data rates with a margin greater than or equal to the configured margin. If the data rates cannot be obtained, the system continues to attempt the data rate. If it does not achieve it, the modems will not sync.

When a connection is lost in any mode (the cable disconnected, for example), the system attempts reconnection as if it has been reset.

Reach, Data Rate, SNR Margin, and Noise Environment

The maximum transmission rate of the Megabit Modem 310F and 320F is determined by distance, SNR margin, and the condition of the line (wire gauge, condition noise environment). The figure on [page 49](#) shows the relationship between reach and data rate for a given set of conditions. The plots can be used to determine the achievable reach at a given data rate, or they may be used to determine the achievable data rates at a given distance. In all cases except the no noise case, a margin of 4 dB was allocated above the SNR that provides a Bit Error Rate (BER) of 10^{-7} .

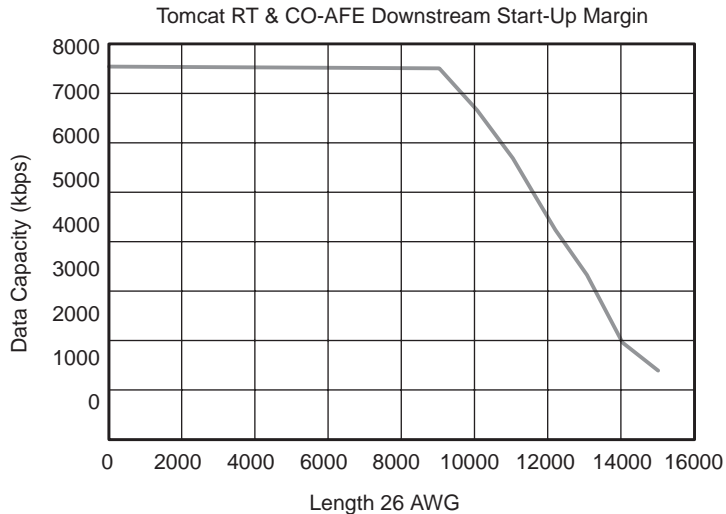
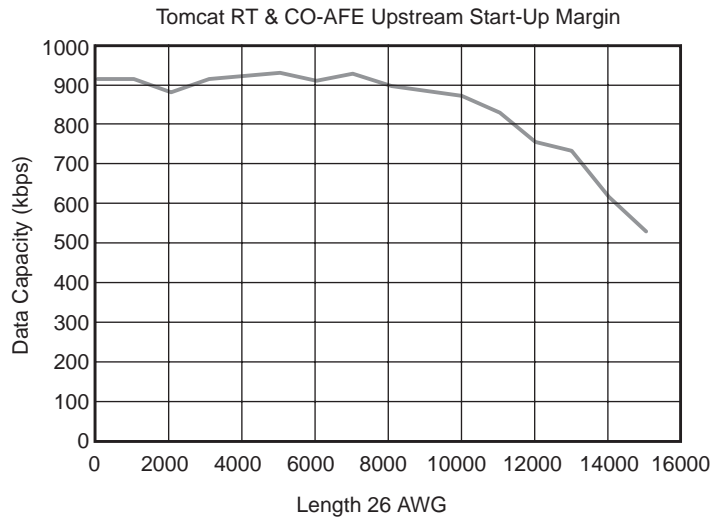

The reach tables above are for a noiseless environment.



The performance shown is typical for ADC Megabit Modem products. Due to variations in environment and test setup, ADC does not guarantee performance to the figures shown.

You can configure the Megabit Modem 310F and 320F startup margin setting. This setting defaults to 4 dB but may be set from 0 - 15 dB. The modems will attempt to come up at the programmed margin setting. Setting the margin high allows for a cushion against changing line conditions and impulse noise. Setting the margin low provides less protection but allows the modems to come up at a higher data rate (if in rate-adaptive mode) or at a longer loop length (if in fixed data rate mode). The default setting of 3 dB is recommended and provides an overall BER better than 10^{-10} . Reducing the setting to 0 dB will provide a BER of less than 10^{-7} and is not recommended.

TECHNICAL SPECIFICATIONS AND CONNECTOR PINOUTS



TECHNICAL SPECIFICATIONS

ADSL Line

Signal Format	DMT Line Code
Transmit Signal Power	up to 23 dBm
Connector	RJ-11

Ethernet Port

Connector	8-pin modular, 10BASE-T
Bandwidth Filtering	14 Kpps (64-byte packets, both directions)
Address Learning	8,192 MAC addresses with aging
Encapsulation Format	HDLC
Bridging	IEEE 802.1d transparent with learning on the LAN port only

Physical

Height	1.25 in (3.175 cm)
Width	6.75 in (17.15 cm)
Depth	5.5 in. (14.0 cm)
Weight	1.38 lb. (0.63 kg)

Electrical

Power Input	100 to 240 Vac, 50-60 Hz
Power Dissipation	
Megabit Modem 320F (ATU-R)	3 W
Megabit Modem 310F (ATU-C)	4 W

Environmental

Operating Temperature	+32 to +122 °F (0 to 50 °C)
Relative Humidity	0 to 95% non-condensing
Operating Altitude	-200 to 13,000 ft. (-61 to 3962 meters)
Electromagnetic Emissions	Per FCC Part 15 Class B
Storage Temperature	-40 to 158 °F (-40 to 70 °C)
Storage Altitude	-1,000 to 30,000 ft. (-305 to 9,144 meters)

ASCII Terminal Maintenance Port

Type	RS-232C, RJ-45
Data Rate	Autobaud from 2400 to 19,200 baud
Hardware Flow Control	Not Supported

COMPLIANCE

Emissions and Immunity Compliance	FCC Part 15, Subpart B, Class B CENELEC/ETSI (IEC 801-2, -3, -4) CE (EN 55022 and EN 50082-1)
Operations and Safety Compliances	UL1950 and cUL CE (EN 60950)

CONNECTOR PINOUTS

The following table shows connector pin assignments for the RJ-11 DSL connector.

Pin	Signal
1	Not Used
2	Not Used
3	ADSL Ring
4	ADSL Tip
5	Not Used
6	Not Used

The following table shows connector pin assignments for the 8-pin 10BASE-T Ethernet connector. The connector is MDI-X.

MDI Pin	MDI-X Pin	Signal	Description
1	3	TD+	Transmit Data (+)
2	6	TD-	Transmit Data (-)
3	1	RD+	Receive Data (+)
4	4	-	-
5	5	-	-
6	2	RD-	Receive Data (-)
7	7	-	-
8	8	-	-

The following table shows connector pin assignments for the 8-pin RS-232 port connector.

Pin	Signal	Signal Direction
1	Not Used	-
2	Receive Data (RD)	Modem to terminal
3	Transmit Data (TD)	Terminal to modem
4	Data Terminal Ready (DTR)	Terminal to modem
5	DGND	-
6	Data Set Ready (DSR)	Modem to terminal
7	Not Used	-
8	Not Used	-

CONTACTING ADC



ADC Customer Service Group provides expert pre-sales and post-sales support and training for all its products. Technical support is available 24 hours a day, 7 days a week by contacting the ADC Technical Assistance Center (TAC).

Sales Assistance

800.366.3891 extension 73000 (USA and Canada)
952.917.3000
Fax: 952.917.3237

- Quotation Proposals
- Ordering and Delivery
- General Product Information

Systems Integration

800.366.3891, extension 73000 (USA and Canada)
952.917.3000

- Complete Solutions (from concept to installation)
- Network Design and Integration Testing
- System Turn-Up and Testing
- Network Monitoring (upstream or downstream)
- Power Monitoring and Remote Surveillance
- Service/Maintenance Agreements
- Systems Operation

ADC Technical Assistance Center

800.638.0031
714.730.3222
Fax: 714.730.2400
Email: wsd_support@adc.com

- Technical Information
- System/Network Configuration
- Product Specification and Application
- Training (product-specific)
- Installation and Operation Assistance
- Troubleshooting and Repair/Field Assistance
- www.adc.com/Knowledge_Base/index.jsp

Online Technical Support

Online Technical Publications

- www.adc.com/library1/

Product Return Department

800.366.3891 ext. 73748 or
952.917.3748
Fax: 952.917.3237
Email: repair&return@adc.com

- ADC Return Material Authorization (RMA) number and instructions must be obtained before returning products.

All telephone numbers with an 800 prefix are toll-free in the USA and Canada.

LIMITED WARRANTY

ADC DSL Systems, Inc. (“ADC”) warrants that, for a period of 12 months from the date of shipment, the hardware portion of its products will be free of material defects and faulty workmanship, under normal use. ADC's obligation, under this warranty, is limited to replacing or repairing, at ADC's option, any such hardware product which is returned during the 12-month warranty period per ADC's instructions and which product is confirmed by ADC not to comply with the foregoing warranty.

ADC warrants that, for a period of 90 days from the date of purchase, the software furnished with its products will operate substantially in accordance with the ADC published specifications and documentation for such software. ADC's entire liability for software that does not comply with the foregoing warranty and is reported to ADC during the 90-day warranty period is, at ADC's option, either (a) return of the price paid or (b) repair or replace of the software. ADC also warrants that, for a period of 30 days from the date of purchase, the media on which software is stored will be free from material defects under normal use. ADC will replace defective media at no charge if it is returned to ADC during the 30-day warranty period along with proof of the date of shipment.

The transportation charges for shipment of returned products to ADC will be prepaid by the Buyer. ADC will pay transportation charges for shipment of replacement products to Buyer, unless no trouble is found (NTF), in which case the Buyer will pay transportation charges.

ADC may use reconditioned parts for such repair or replacement. This warranty *does not* apply to any product which has been repaired, worked upon, or altered by persons not authorized by ADC or in ADC's sole judgment has subjected to misuse, accident, fire or other casualty, or operation beyond its design range.

The warranty for repaired products shall remain in effect until the end of the original warranty period.

ADC DISCLAIMS ALL OTHER WARRANTIES, EITHER EXPRESS OR IMPLIED, INCLUDING BUT NOT LIMITED TO IMPLIED WARRANTIES OF MERCHANTABILITY AND FITNESS FOR A PARTICULAR PURPOSE, WITH RESPECT TO ITS PRODUCTS AND ANY ACCOMPANYING WRITTEN MATERIALS. FURTHER, ADC DOES NOT WARRANT THAT SOFTWARE WILL BE FREE FROM BUGS OR THAT ITS USE WILL BE UNINTERRUPTED OR REGARDING THE USE, OR THE RESULTS OF THE USE, OF THE SOFTWARE IN TERMS OF CORRECTNESS, ACCURACY, RELIABILITY OR OTHERWISE.

GLOSSARY

D

The Glossary defines technical terms and abbreviations used in this manual.

ADSL	Asymmetric Digital Subscriber Line. A method of transmitting at different downstream and upstream speeds.
Asymmetric Transmission	Transmission which sends data at different rates in each direction.
ATU-C	ADSL Terminal Unit at the service provider site.
ATU-R	ADSL Terminal Unit at the remote site.
Bandwidth	Used to describe the capacity or amount of traffic (data, voice, or video) a certain communications line is capable of accommodating.
BER	Bit Error Rate. The ratio of received bits that are in error.
Binder Group	A group of 25 or 50 pairs of wires.
Bit	In a binary system, the smallest unit of information. It is represented as a zero or a one.
Bridge	A two-port internetworking device that selectively filters or forwards traffic based on MAC addresses.
Bridged	A pair of wires connected in parallel across a single line to form a "T" Tap configuration.
Downstream	The direction of data reception from the Megabit Modem 310F to the Megabit Modem 320F.
Ethernet	A baseband LAN specification that has become a series of standards produced by IEEE referred to as IEEE 802.3.
HDLC	High-level Data Link Control.
Hub	A common wiring point for star-topology networks, and a common synonym for a concentrator.
IEEE	Institute of Electrical and Electronics Engineers. A professional organization that defines network standards.
kbps	Kilobits per second. A measure of transmission speed at 1,000 bits per second.
kpps	Kilo packets per second.
LAN	Local Area Network. The means by which a local community of users and workgroups can share information and resources electronically.
LED	Light emitting diode.

Line code	Any method of converting digital information to analog form for transmission on a communication line.
Link	Another term used for transmission line.
MAC	Media Access Control. Associated with Layer 2 or the Data Link Layer of the ISO 7-layer protocol model.
Margin	An ADSL parameter, measured in dB. It indicates the excess SNR, relative to the performance of 10^{-7} BER, at the receiver point.
Mbps	Megabits per second. 1,000,000 bits per second.
MDI	Media Dependent Interface.
MDI-X	Media Dependent Interface (cross-over).
NVRAM	Non-volatile RAM.
Port	An I/O interface. A point at which signals may be introduced or extracted in a similar manner.
POTS	Plain Old Telephone Service.
RAM	Random Access Memory.
RFC	Request for Comment.
SNR	Signal-to-Noise ratio.
Telecommuter	A person who performs work at home while linked to the office by means of a telecommunications-equipped computer system.
Upstream	The direction of data transmission from the Megabit Modem 320F to the Megabit Modem 310F.
WAN	Wide Area Network. In this manual, refers to the ADSL link.

ADC DSL Systems, Inc.

14402 Franklin Avenue
Tustin, CA 92780-7013

Tel: 714.832.9922

Fax: 714.832.9924

Technical Assistance

Tel: 800.638.0031

Fax: 714.730.3222



1220432



Free Manuals Download Website

<http://myh66.com>

<http://usermanuals.us>

<http://www.somanuals.com>

<http://www.4manuals.cc>

<http://www.manual-lib.com>

<http://www.404manual.com>

<http://www.luxmanual.com>

<http://aubethermostatmanual.com>

Golf course search by state

<http://golfingnear.com>

Email search by domain

<http://emailbydomain.com>

Auto manuals search

<http://auto.somanuals.com>

TV manuals search

<http://tv.somanuals.com>