

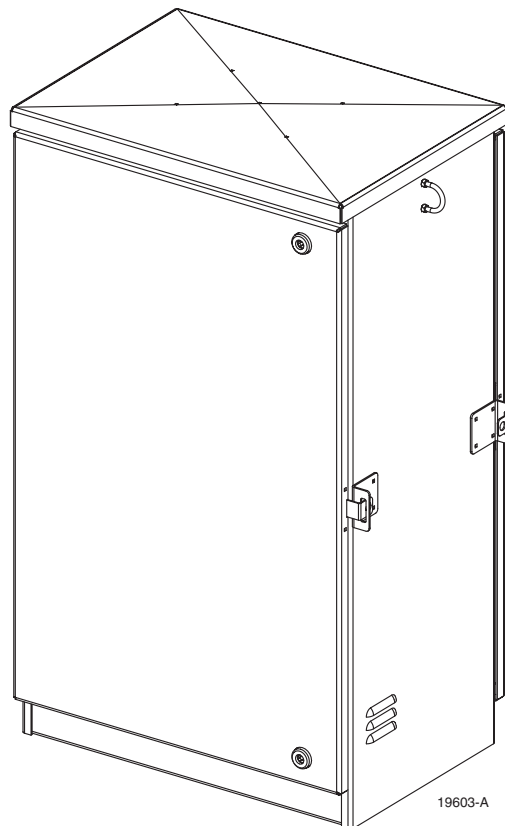

Fiber Distribution Terminal ACE-142S/142V Cabinet User Manual



COPYRIGHT

© 2004, ADC Telecommunications, Inc.
All Rights Reserved
Printed in the U.S.A.

REVISION HISTORY

ISSUE	DATE	REASON FOR CHANGE
1	07/2004	Original release.

LIST OF CHANGES

The technical changes incorporated into this issue are listed below.

PAGE	IDENTIFIER	DESCRIPTION OF CHANGE
All		Original release

TRADEMARK INFORMATION

ADC and ADC Telecommunications are registered trademarks of ADC Telecommunications, Inc.
Telcordia is a registered trademark of Telcordia Technologies, Inc.

DISCLAIMER OF LIABILITY

Contents herein are current as of the date of publication. ADC reserves the right to change the contents without prior notice. **In no event shall ADC be liable for any damages resulting from loss of data, loss of use, or loss of profits and ADC further disclaims any and all liability for indirect, incidental, special, consequential or other similar damages. This disclaimer of liability applies to all products, publications and services during and after the warranty period.**

This publication may be verified at any time by contacting ADC's Technical Assistance Center at 1-800-366-3891, extension 73475 (in U.S.A. or Canada) or 952-917-3475 (outside U.S.A. and Canada), or by e-mail to bcg_tac@adc.com.



ADC Telecommunications, Inc.
P.O. Box 1101, Minneapolis, Minnesota 55440-1101
In U.S.A. and Canada: 1-800-366-3891
Outside U.S.A. and Canada: (952) 938-8080
Fax: (952) 917-1717

TABLE OF CONTENTS

Content	Page
ABOUT THIS MANUAL	v
Related Publications	v
ADMONISHMENTS	v
GENERAL SAFETY PRECAUTIONS	v
STANDARDS CERTIFICATION	vi
LIST OF ACRONYMS AND ABBREVIATIONS	vi
1 DESCRIPTION	1
1.1 ACE-142S/142V Cabinet	1
1.2 Accessories and Replacement Parts	4
2 BEFORE STARTING THE INSTALLATION	5
2.1 Installation Overview	5
2.2 Unpacking and Inspection	5
2.3 Cabinet Installation Hardware	6
2.4 Tools and Materials Required for Installation	6
2.5 Cabinet Mounting	7
3 MOUNTING THE CABINET ON A FIBERGLASS MOUNTING SLEEVE	8
3.1 Installation Recommendations	8
3.2 Excavation	9
3.3 Placement of the FMS	9
3.4 Cable Conduit Installation	10
3.5 Grounding System Installation	10
3.6 Back Fill	10
3.7 Mounting the Cabinet on the FMS-20000	10
4 MOUNTING THE CABINET ON A CONCRETE PAD	15
4.1 Installation Recommendations	15
4.2 Cable Conduit Installation	15
4.3 Base Installation	15
4.4 Concrete Pad Construction	17
4.5 Grounding System Installation	18
4.6 Mounting the Cabinet on the Concrete Pad	18
5 FEEDER CABLE INSTALLATION AND SPLICING	22
5.1 Bottom Cover Removal	22
5.2 Cabinet Grounding Wire Connection	22
5.3 Feeder Cable Installation	23
5.4 Feeder Cable and Splitter Input Fiber Splicing	26
6 DISTRIBUTION CABLE INSTALLATION AND SPLICING	29
6.1 Distribution Cable Installation	29
6.2 Bottom Cover Installation	32
6.3 Distribution Cable and Connector Panel Pigtail Splicing	33
7 GUIDELINES FOR USING ROUND SPLICE TRAYS	37
8 PRE-INSTALLED DISTRIBUTION CABLE CONFIGURATION	41

TABLE OF CONTENTS

Content	Page
9 CONNECTOR PANEL INSTALLATION	42
10 SPLITTER MODULE INSTALLATION	43
11 ROUTING AND CONNECTING THE SPLITTER OUTPUT FIBERS	45
11.1 Storing The Splitter Output Fibers	45
11.2 Enabling Service To a Subscriber	46
12 MAINTENANCE AND REPAIR PROCEDURES	47
12.1 Painting	47
12.2 Adapter Replacement	47
12.3 Connector Replacement	48
13 CUSTOMER INFORMATION AND ASSISTANCE	49

ABOUT THIS MANUAL

This publication provides a complete description of the Fiber Distribution Terminal (FDT) ACE-142S/142V Cabinet. Also included are procedures for mounting the cabinet, installing and splicing the feeder and distribution cables, installing additional connector panels and splitter modules, connecting the splitter output fibers to the distribution fibers, and replacing damaged components.

RELATED PUBLICATIONS

Listed below are related manuals and their publication numbers. Copies of these publications can be ordered by contacting the ADC Technical Assistance Center at 1-800-366-389, extension 73475 (in U.S.A. or Canada) or 1-952-917-3475 (outside U.S.A. and Canada).

Title	ADCP Number
Round Splice Tray Cable Routing Instructions	90-321
Optical Fiber Systems Cleaning and Mating Instructions	90-159

ADMONISHMENTS

Important safety admonishments are used throughout this manual to warn of possible hazards to persons or equipment. An admonishment identifies a possible hazard and then explains what may happen if the hazard is not avoided. The admonishments — in the form of Dangers, Warnings, and Cautions — must be followed at all times. These warnings are flagged by use of the triangular alert icon (seen below) and are listed in descending order of severity of injury or damage and likelihood of occurrence.



Danger: *Danger is used to indicate the presence of a hazard that **will** cause severe personal injury, death, or substantial property damage if the hazard is not avoided.*



Warning: *Warning is used to indicate the presence of a hazard that **can** cause severe personal injury, death, or substantial property damage if the hazard is not avoided.*



Caution: *Caution is used to indicate the presence of a hazard that **will** or **can** cause minor personal injury or property damage if the hazard is not avoided.*

GENERAL SAFETY PRECAUTIONS



Warning: *Wet conditions increase the potential for receiving an electrical shock when installing or using electrically-powered equipment. To prevent electrical shock, never install or use electrical equipment in a wet location or during a lightning storm.*



Danger: Do not look into the ends of any optical fiber. Exposure to laser radiation may result. Do not assume the laser power is turned-off or that the fiber is disconnected at the other end.



Danger: Use adequate lifting equipment when moving or installing Fiber Distribution Terminal cabinets. Verify that the maximum lift weight rating of the equipment is sufficient to handle the weight of the cabinet.



Danger: Do not stand under a Fiber Distribution Terminal cabinet as it is being hoisted into position for mounting. A failure of the lifting equipment or apparatus could result in serious personal injury.



Warning: Before digging, check with all local utilities for the presence of buried cables or pipes. Contact with underground cables or pipes, especially electric power cables and gas service lines, could interrupt local utility service and cause serious personal injury and extensive property damage.

STANDARDS CERTIFICATION

Telcordia: This equipment complies with the applicable sections of GR-2898-CORE (Issue 2, December 1999)

LIST OF ACRONYMS AND ABBREVIATIONS

The acronyms and abbreviations used in this manual are detailed in the following list:

AWG	American Wire Gauge
C	Centigrade
F	Fahrenheit
FDT	Fiber Distribution Terminal
FMS	Fiberglass Mounting Sleeve
FTTP	Fiber To The Premises
OSP	Outside Plant
PMF	Pad Mount Frame

1 DESCRIPTION

This section provides a description of the ACE-142S/142V cabinet plus specifications. Also included is a listing of the various accessories and kits.

1.1 ACE-142S/142V Cabinet

The ACE-142S/142V cabinet is a secure, above-ground, outdoor fiber optic distribution cabinet that is designed to hold the splice trays, splitters, connector panels, and connector storage panel required for various Fiber To The Premises (FTTP) applications. A typical ACE-142S/142V cabinet (with splitter modules and connector panels installed) is shown in [Figure 1](#).

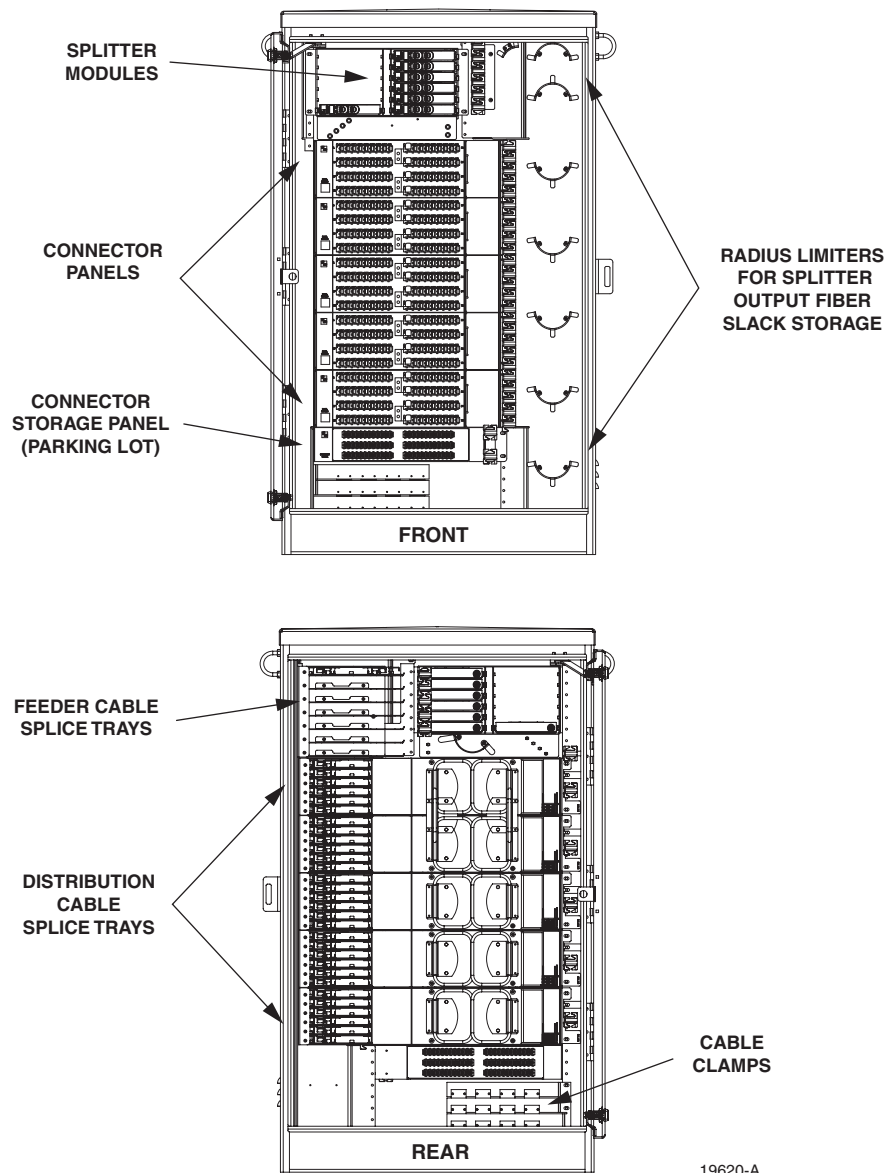

Figure 1. Typical ACE-142S/142V Cabinet

The outside plant (OSP) feeder and distribution cables enter the cabinet from the bottom rear side. Clamps are provided for securing each cable to the inside of the cabinet. The bottom of the cabinet is enclosed with a two-piece removable moisture barrier. The cable entry/exit holes are fitted with grommets to resist the entry of dust and moisture. On an optional basis, the cabinet may be ordered with the distribution cables pre-installed.

The ACE-142S/142V cabinet is constructed of heavy gauge aluminum and is coated with an almond-colored finish. The cabinet doors are equipped with tamper-resistant latches with hasps for padlocks, stainless steel hinges, and door catches to prevent accidental closing. Access to the cabinet requires a 216B key tool (accessory) to operate the latches. Lifting eyes are attached to the sides of the cabinet to allow use of hoisting equipment. A grounding bus is provided within the cabinet for grounding the cabinet and cables per local practice.

The ACE-142S/142V cabinet can accommodate up to thirty-seven round splice trays, up to twelve 1x8 or 1x32 splitter modules, and five 72-position connector panels equipped with APC/SC adapters. Seven splice tray slots are provided for feeder cable splices. Thirty splice tray slots are provided for distribution cable splices. The ACE-142S/142V cabinet is equipped with two doors that provide front and rear access to the optical components. The specifications for the ACE-142S/142V cabinet are provided in [Table 1](#).

Table 1. ACE-142S/142V Cabinet Specifications

PARAMETER	SPECIFICATION
Cabinet	
Dimensions (W x D x H) – See Figure 2	27.5 x 19.7 x 47.5 inches (699 x 500.4 x 1206.5 mm)
Weight (fully loaded)	210 lbs (95.3 kg)
Certification (Pending)	GR-2898-CORE (Issue 2, December 1999)
Distribution ports	360 (with 5 connector panels installed)
Distribution port connectors	APC/SC
Splitter module capacity (1x8 or 1x32)	12
Splice tray capacity (round)	
Feeder cable	7
Distribution cable	30
Total feeder cable splices	84 (7 splice trays with 12 splices per tray)
Total distribution cable splices	360 (30 splice trays with 12 splices per tray)
Splitter Modules	
Splitter module output pigtails	2 mm with APC/SC connectors
Splitter module input pigtail	2 mm
Test bandpass	1260–1360 nm 1480–1500 nm 1550–1560 nm
Overall bandpass	1260–1625 nm

Table 1. ACE-142S/142V Cabinet Specifications, continued

PARAMETER	SPECIFICATION
Insertion loss at test bandpass 1x8 standard APC/SC 1x32 standard APC/SC	11.1 dB Maximum (Including connector) 17.8 dB Maximum (Including connector)
Return loss at test bandpass 1x8 standard APC/SC 1x32 standard APC/SC	>55 dB >55 dB

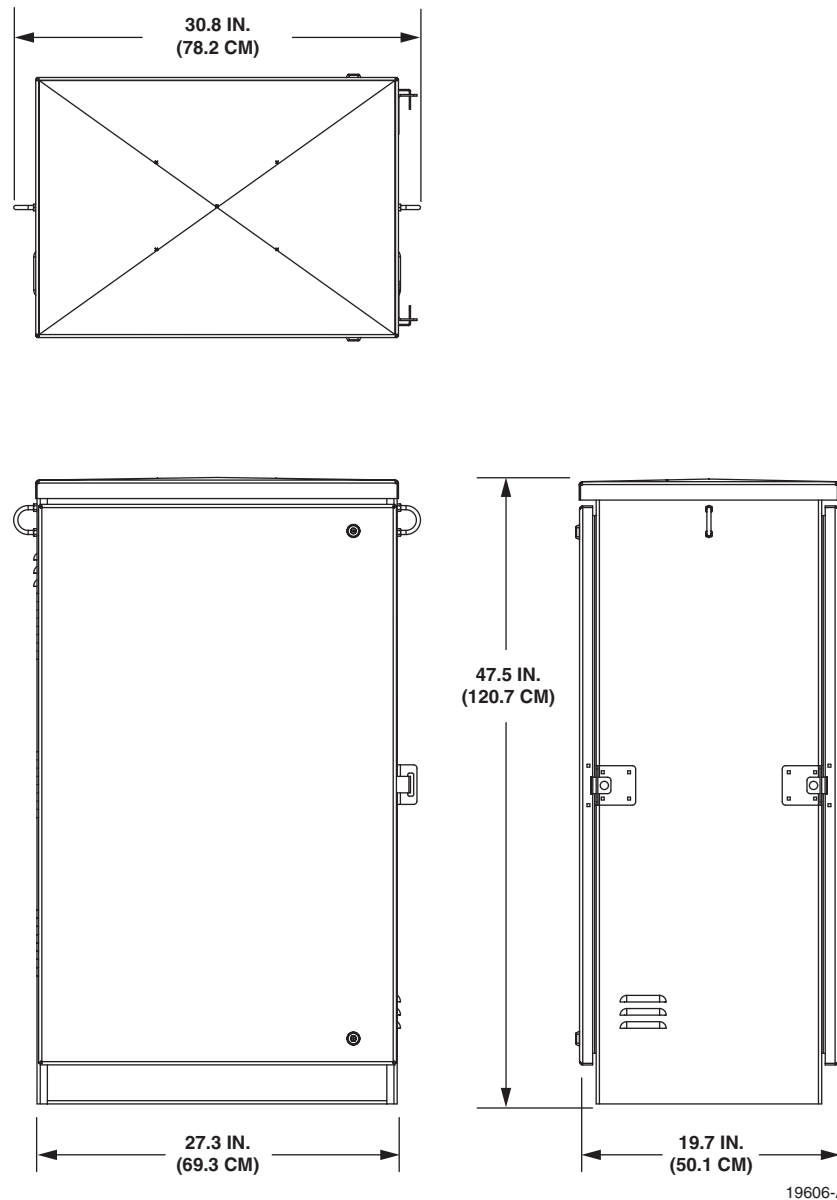

Figure 2. ACE-142S/142V Cabinet Dimensions

1.2 Accessories and Replacement Parts

Refer to [Table 2](#) and [Table 3](#) for a listing of the various accessories and replacement parts that are available for the ACE-142S/142V cabinet.

Table 2. ACE-142S/142V Cabinet Accessories and Replacement Parts

DESCRIPTION	CATALOG NUMBER
Mounting Kits	
Fiberglass Mounting Sleeve (see Figure 3 for dimensions)	FMS-20000
FMS sleeve cover	FCVR-200CVR
FMS adapter cover	FCVR-200ACE1000
Concrete pad mount frame (PMF) kit	ACE-100PMF
Ground spacer	ACE-ACCSPCRO6S-102
Cable Hardware Kits	
Blocking kit, loose buffer tube	FBK-OSP002
Clamping kit	OSP-CLPSST
Grounding kit, loose buffer tube	GND-STPKIT
Cable grommet kit	ACE-ACC-CBLGRMT
Miscellaneous	
216B key tool (required to open cabinet door)	OSP-216BKEY1
Splice wheel, HS	FST-DRS12-HS
Splice wheel, mechanical	FST-DRS12-MT
Touch-up paint - Almond	ACE-ACC-PTALMD
Filter replacement kit	OSP-FLTRKIT1
Cleaning kit	FPC-CLNKIT1
Straight retainer kit	FBA-ASCZ-S/R

Table 3. ACE-142S/142V Cabinet Splitter Modules

DESCRIPTION OF SPLITTER MODULE	CATALOG NUMBER
1x8, standard, APC/SC	FPS-SPK1AOJ
1x32, standard, APC/SC	FPS-SPK1JOJ

2 BEFORE STARTING THE INSTALLATION

This section provides general installation considerations, unpacking and inspection procedures, and lists the tools and materials required for cabinet installation.

2.1 Installation Overview

Installation of the ACE-142S/142V cabinet involves the following main tasks:

Installing a Support Base—The cabinet must be mounted on a suitable support base. The following two mounting options are available:

- **Fiberglass Mounting Sleeve (FMS)**—The FMS provides a stable mounting platform plus storage space under the cabinet for OSP cable slack. The FMS may also be used as a splicing vault for the OSP feeder and distribution cables.
- **Poured Concrete Pad**—Concrete slab with Pad Mounting Frame (PMF). The PMF provides a stainless-steel frame for mounting the cabinet. The PMF ensures that the cabinet will be securely anchored to the concrete slab.

Mounting the Cabinet—After the support base is installed, the cabinet is secured to the support base.

Feeder and Distribution Cable Installation—The cabinet OSP feeder and distribution cables are routed into the cabinet and spliced.

Connector Panel Installation—Additional connector panels are installed in the cabinet if needed.

Splitter installation—Additional splitters are installed in the cabinet if needed.

2.2 Unpacking and Inspection

This section provides instructions for opening the shipping boxes, verifying that all parts have been received, and verifying that no shipping damage has occurred.

Use the following procedure to unpack and inspect the cabinet and all accessories:

1. Open the shipping carton(s) and carefully unpack the cabinet and any accessories from the protective packing material.
2. Open the cabinet doors (requires 216B key tool) and check for broken or missing parts. If there are damages, contact ADC (see [Section 13](#)) for an RMA (Return Material Authorization) and to reorder if replacement is required.

2.3 Cabinet Installation Hardware

The cabinet is shipped with fasteners (see [Table 4](#)) for securing the ACE-142S/142V cabinet to the FMS or the PMF.

Table 4. Cabinet Installation Fasteners

ITEM	QUANTITY
3/8 x 1-inch hex head capscrews	4
3/8-inch flat washers	4
3/8-inch lock washers	4

2.4 Tools and Materials Required for Installation

The following tools and materials are required for cabinet installation:

All Installations

- 9/16-inch wrench
- Hammer
- Wire cutter
- Utility knife
- Screwdriver (flat blade)
- Tape measure
- Pen or marker
- 216B key tool (required to open cabinet door)
- Padlock (optional)
- Grounding system, copper wire, and grounding clamp (per local requirements)
- Splicing equipment for splicing OSP feeder and distribution cables
- Lifting equipment for hoisting the cabinet into position for mounting

Fiberglass Mounting Sleeve Installations

- Fiberglass Mounting Sleeve (FMS), FMS sleeve cover, FMS adapter cover (see [Table 2](#))
- Excavation and earth moving equipment
- Stone aggregate
- Tamping equipment
- Level
- Hole saw and drill (use to cut holes for cable conduit if pre-drilled holes are not usable)
- Landscaping equipment and site restoration supplies

Concrete Pad Installations

- Pad Mount Frame kit for ACE-142
- Excavation and earth moving equipment
- Concrete finishing equipment
- Approximately 10 cu. ft. concrete
- Sand or gravel
- Tamping equipment
- 2 x 6 inch framing lumber
- 1 x 4 inch wooden stakes (4)
- Nails and construction screws
- Utility wire (to secure PMF during installation)
- Saw
- Drill with screwdriver bits
- Square
- Level
- Landscaping equipment and site restoration supplies

2.5 Cabinet Mounting

The next two sections provides instructions for mounting the cabinet on either a fiberglass mounting sleeve or concrete pad. Use whichever procedure is appropriate for the installation.

3 MOUNTING THE CABINET ON A FIBERGLASS MOUNTING SLEEVE

The FMS-20000, shown in Figure 3, is a fiberglass and polymer concrete sleeve that may be used to support the cabinet at ground level. The FMS may also be used as a splicing vault. Four vertical racks are molded into the sides of the FMS to accommodate removable rungs (not provided). The rungs provide support for splice cases or OSP cable storage.

3.1 Installation Recommendations

The site chosen for the installation must conform to all local codes and any permits required must be obtained prior to the start of installation. The location must be accessible and provide adequate parking for worker and vehicle safety.

The installed cabinet must not create a visual or physical obstruction to vehicular or pedestrian traffic. Ensure that there is sufficient space on all sides to facilitate cabinet installation. Depending on the landscaping requirements, the top surface of the mounting sleeve may be located from 0 to 4 inches (10.2 cm) above the surrounding grade.

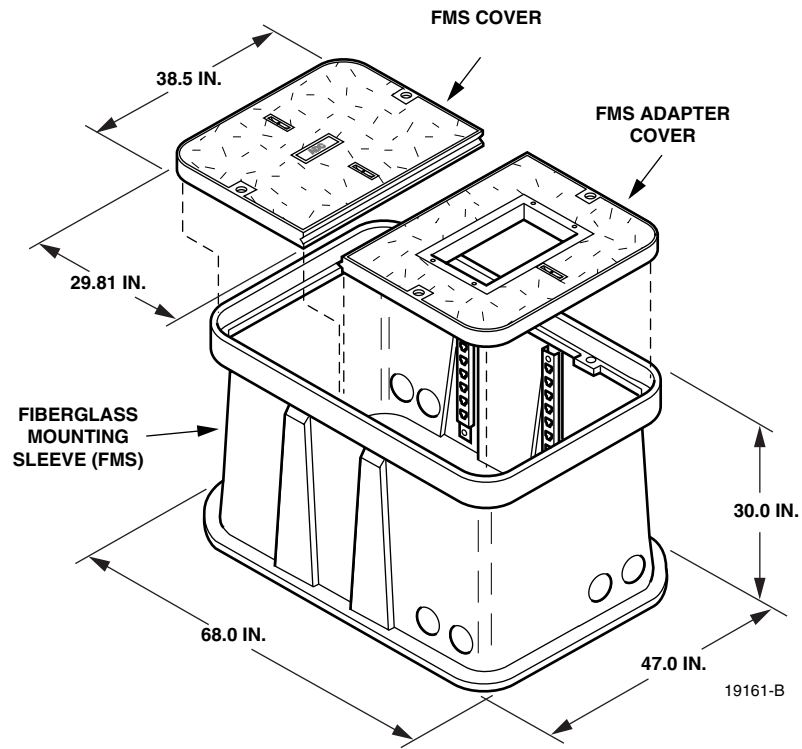

Figure 3. Fiberglass Mounting Sleeve (FMS-20000)

3.2 Excavation

The excavation must be large enough to provide a fill base that will maintain stability for the FMS and the cabinet mounted on it. There must be room for 12 inches (30.5 cm) of fill below and on each side of the FMS. The excavation dimensions for the FMS 20000 are shown in Figure 4. Excavate a rectangular hole for the FMS.

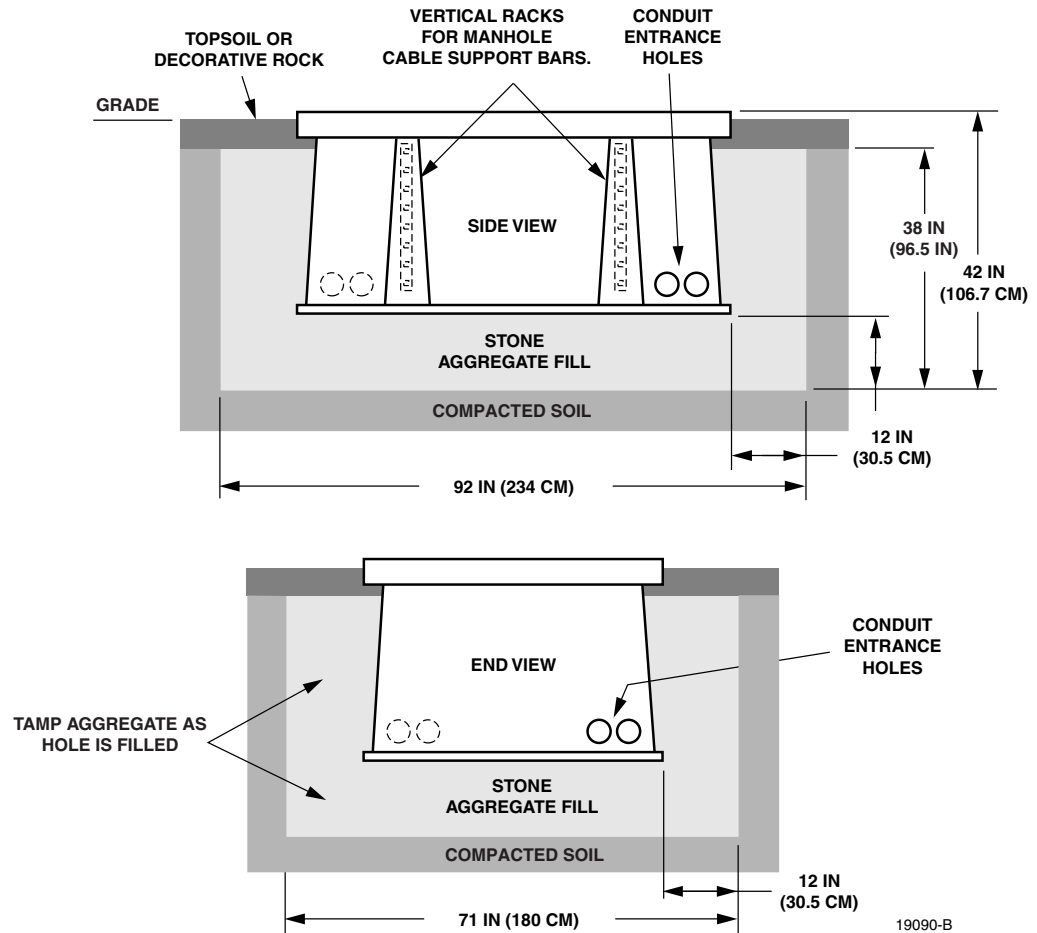

Figure 4. Excavation Recommendations for FMS-20000

3.3 Placement of the FMS



Danger: Use adequate lifting equipment when installing the FMS. Do not stand in the hole while placing the FMS in position. An unexpected shift of the FMS could result in personal injury.

Use the following procedures to place the FMS into the excavation.

1. Fill the bottom of the hole with stone aggregate, tamping it as it is filled to build a 12 inch (30.5 cm) layer with a level surface. The stone aggregate will provide a stable base to support the FMS.

- ▶ **Note:** Use crushed rock 3/8-inch or less in size mixed with stone dust (per local practice) to fill the hole. The name of the material may differ in different geographical areas. Possible names are Class 5, stone dust, aughts (0s) and ones (1s), or stone aggregate
- 2. Use appropriate lifting equipment to place the FMS into the center of the hole. Lifting loops are provided on either side of the FMS for attaching a sling or chain.
- 3. Use a carpenter's level to verify that the FMS is level. If it is necessary to add or remove fill for leveling, tamp any added fill to maintain the base stability.

3.4 Cable Conduit Installation

Select the conduit entrance hole(s) for the OSP feeder and distribution cables. Refer to [Figure 4](#) for the location of the holes. If necessary, additional conduit entrance holes may be cut using a power drill and hole saw. Place and route the conduit into the entrance hole(s). If preferred, the FMS may be installed without conduit. OSP cables may be routed into the FMS at any point that is convenient. Cut the cable entrance hole to match the size of the cable.

3.5 Grounding System Installation

Install a grounding system (not provided) that meets all local electrical codes. Check local codes for grounding system installation, use of clamps, wire size, and any other grounding requirements. Typically, #6 AWG copper wire is used for the grounding wire. Install the grounding system inside the FMS where it will not interfere with the conduit or cables. Connect the grounding wire to the grounding system. Leave sufficient slack in the grounding wire to allow it to be routed into the cabinet after the cabinet is mounted on the sleeve.

3.6 Back Fill

If installing conduit, hand shovel stone aggregate under the conduit to avoid damage from the power tamper. Complete the back fill as follows:

1. Add stone aggregate evenly around the FMS and tamp. Fill to approximately 6 inches (15.2 cm) from the top of the excavation.
2. Complete the back-fill with crushed rock or topsoil depending on the landscaping requirements. The top surface of the mounting sleeve may be located from 0 to 4 inches (10.2 cm) above the surrounding grade (see [Figure 4](#)).

3.7 Mounting the Cabinet on the FMS-20000

The following sections provide instructions for mounting the ACE-142S/142V cabinet on the FMS-20000. With the ACE-142S cabinet, the distribution cables must be installed after the cabinet is mounted. With the ACE-142V cabinet, the distribution cables are pre-installed in the cabinet by the factory. If mounting an ACE-142S cabinet, refer to [Section 3.7.1](#) for the cabinet mounting procedure. If mounting an ACE-142V cabinet with pre-installed distribution cables, refer to [Section 3.7.2](#) for the cabinet mounting procedure. Use the 216B key tool to un-latch and latch the cabinet doors as needed during the mounting process.



Warning: Use appropriate lifting equipment when moving or installing the cabinet. Do not stand under a cabinet as it is being hoisted into position for mounting. A failure of the lifting equipment could result in serious personal injury.

3.7.1 Mounting the ACE-142S Cabinet on the FMS-20000

Use the following procedure to mount an ACE-142 cabinet on the FMS-20000:

1. Install the FMS adapter cover onto the FMS and secure using the two capscrews and flat washers provided with the cover as shown in [Figure 5](#). Tighten each capscrews securely.

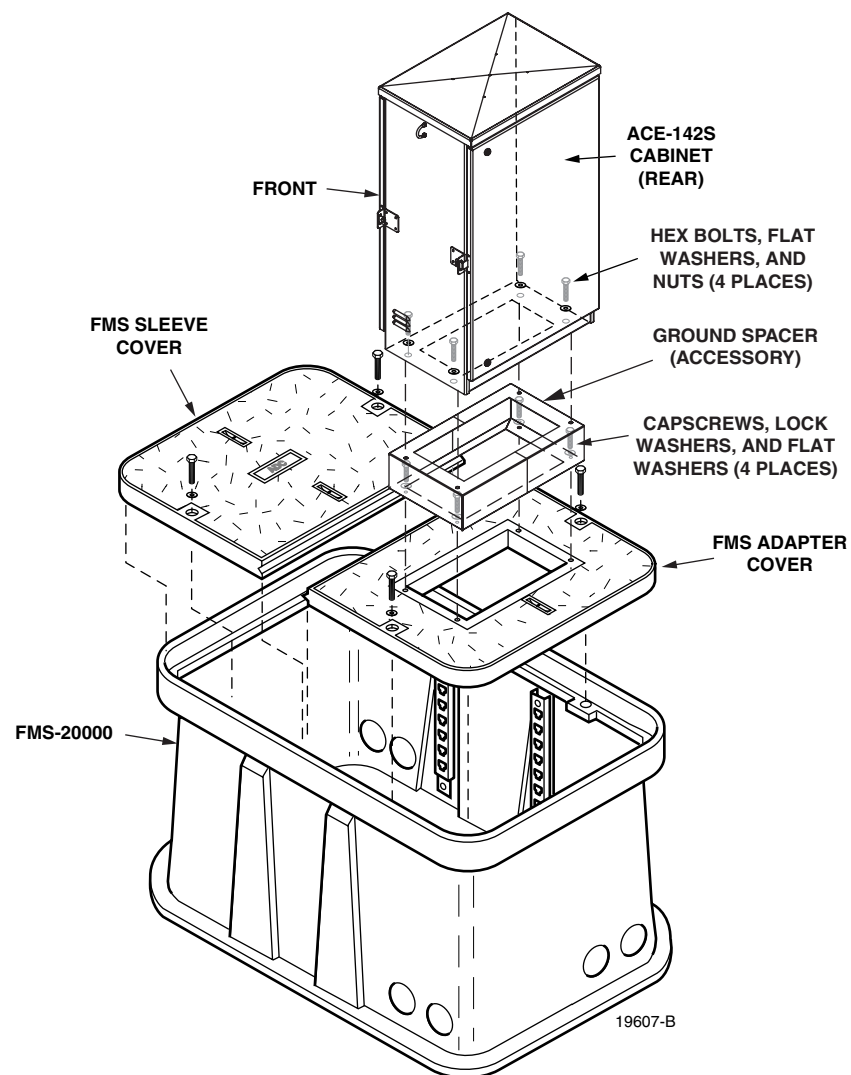

Figure 5. Mounting the ACE-142S Cabinet on the FMS-20000

2. If a ground spacer (accessory) will not be installed, proceed to step 7. If a ground spacer will be installed, align the ends of the left ground spacer section with the ends of the right ground spacer section and then press the two sections together.
3. Place the assembled ground spacer in position for mounting on the adapter cover.
4. Align the mounting holes in the ground spacer with the mounting holes in the adapter cover.
5. Secure the ground spacer to the adapter cover using the four capscrews, four lock washers, and four flat washers provided with the cabinet. Tighten all capscrews securely.
6. Open the rear door of the cabinet and remove the back section of the cabinet bottom cover as described in [Section 5.1](#). Then return to step 7 of this procedure to finish mounting the cabinet.
7. Using appropriate lifting equipment, hold the cabinet in position for mounting onto the ground spacer or adapter cover.
8. Lower the cabinet onto the ground spacer or adapter cover and align the mounting holes in the bottom of the cabinet with the holes in the spacer or cover.
9. If the installation includes a ground spacer, secure the cabinet to the spacer using the four hex bolts, four flat washers and four nuts provided with the spacer. If the installation does not include a ground spacer, secure the cabinet to the adapter cover using the four hex bolts, lock flat washers, and four flat washers provided with the cabinet. Tighten all fasteners securely.
10. If the FMS will be used as a splicing vault for the OSP feeder and distribution cables, install the required splice enclosure.
11. Install the FMS sleeve cover onto the FMS and secure using the two capscrews and washers provided with the cover. Tighten both capscrews securely.

3.7.2 Mounting The ACE-142V Cabinet on the FMS-20000

Use the following procedure to mount the ACE-142V cabinet on the FMS-20000:

1. Mount the FMS adapter cover on the FMS and secure using the two capscrews and flat washers provided with the cover as shown in [Figure 6](#). Tighten each capscrew securely.
2. If a ground spacer (accessory) will not be installed, proceed to step 7. If a ground spacer will be installed, align the ends of the left ground spacer section with the ends of the right ground spacer section and then press the two sections together.
3. Place the assembled ground spacer in position for mounting on the adapter cover.
4. Align the mounting holes in the ground spacer with the mounting holes in the adapter cover.
5. Secure the ground spacer to the adapter cover using the four capscrews, four lock washers, and four flat washers provided with the cabinet. Tighten all capscrews securely.
6. Open the rear door of the cabinet and remove the back section of the cabinet bottom cover as described in [Section 5.1](#). Then return to step 7 of this procedure to finish mounting the cabinet.

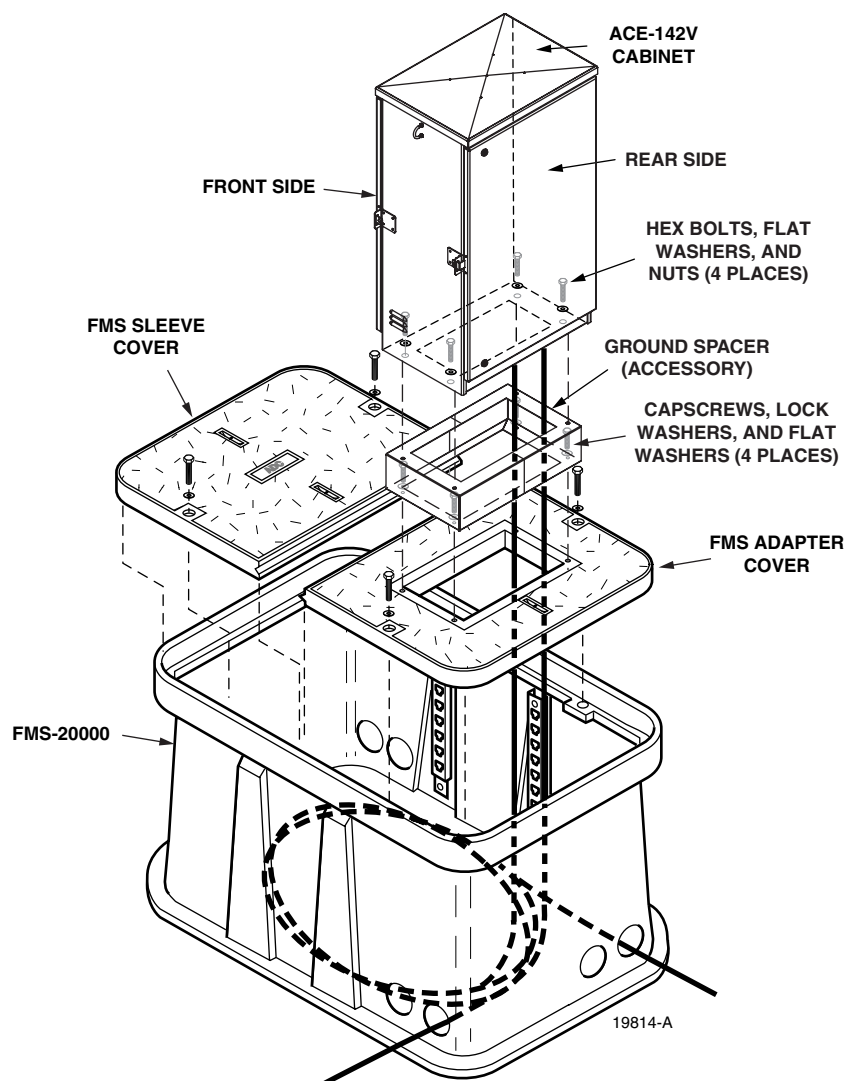

Figure 6. Mounting The ACE-142V Cabinet on the FMS-20000

7. Using appropriate lifting equipment, hold the cabinet in position over the FMS-20000 so the cabinet is suspended over the rectangular opening in the top of the ground spacer or adapter cover.
 8. Carefully route the distribution cables through the rectangular opening in the ground spacer or adapter cover and into the FMS-20000.
- **Note:** The cables are coiled on spools for shipment. On each spool is a label that lists each fiber subunit within the cable and the connector panels where each subunit is terminated. After the cable is unspooled, label each cable with the corresponding fiber subunit and connector panel designations. In addition, tag or label the stub end of each cable so that the cable can be identified after being routed to the splice enclosure.
9. Locate the ends of the conduit sections that were installed in the bottom of the FMS-20000.

10. Feed each distribution cable into the appropriate conduit section and route to the splice enclosure (not provided). Any excess cable slack may be stored in the bottom of the FMS.
 - ▶ **Note:** A separate splice enclosure (not provided) is required for splicing the cabinet OSP distribution cables to the system OSP distribution cables. If preferred, the splice enclosure for the distribution cables may be mounted within the FMS-20000.
11. Lower the cabinet onto the ground spacer or adapter cover and align the mounting holes in the bottom of the cabinet with the holes in the cover.
12. If the installation includes a ground spacer, secure the cabinet to the spacer using the four hex bolts, four flat washers and four nuts provided with the spacer. If the installation does not include a ground spacer, secure the cabinet to the adapter cover using the four capscrews, four lock washers, and four flat washers provided with the cabinet. Tighten all fasteners securely.
13. Install the FMS sleeve cover onto the FMS and secure using the two capscrews and washers provided with the cover. Tighten both capscrews securely.

4 MOUNTING THE CABINET ON A CONCRETE PAD

The Pad Mount Frame (PMF), shown in [Figure 7](#), is a stainless steel frame that provides a mounting base for the cabinet when installed in a concrete pad foundation.



Caution: *Mounting the cabinet directly on a concrete pad may cause chemical corrosive action to the cabinet. Use only the Pad Mount Frame (PMF) as a mounting base for the cabinet. Do not use caulking compounds as a sealer between the cabinet and the PMF.*

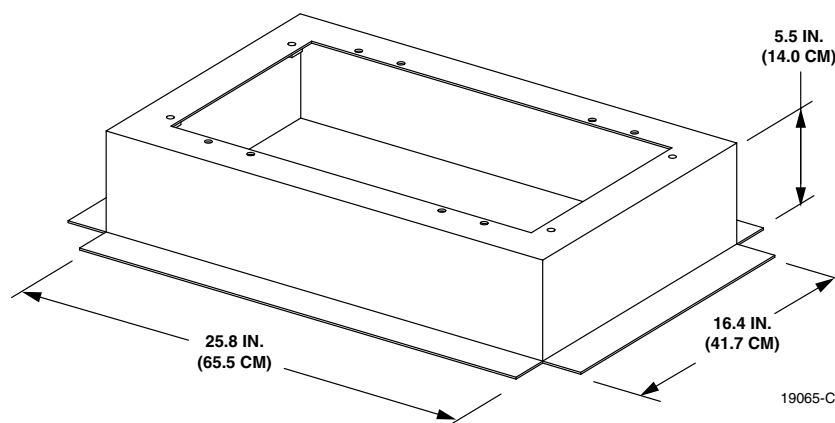

Figure 7. Pad Mount Frame Dimensions

4.1 Installation Recommendations

The site chosen for the installation must conform to all local codes and any permits required must be obtained prior to the start of installation. The location must be accessible and provide adequate parking for worker and vehicle safety. Situate the concrete pad along the trench that was used for routing the OSP fiber cables for the system.

The installed cabinet must not create a visual or physical obstruction to vehicular or pedestrian traffic. Ensure that there is sufficient space on all sides to facilitate cabinet installation. Depending on the landscaping requirements, the top surface of the concrete pad may be located from 0 to 3 inches (7.6 cm) above the surrounding grade.

4.2 Cable Conduit Installation

Install the cable conduit from below as shown in [Figure 8](#) and position it so that the top of each upward bend will be located within the PMF opening at the indicated point. When installed, the top of the conduit should be located 1 to 2 inches (2.54 to 5.08 cm) **below** the top of the finished concrete pad. Install the conduit **before** pouring the pad.

4.3 Base Installation

Prepare a base for the concrete pad that meets all local code requirements. The base must have a footing of 4 to 6 inches (10.2 to 15.2 cm) of sand or gravel (per local practice) on firmly compacted soil. Refer to the construction diagram (see [Figure 8](#)) for details.

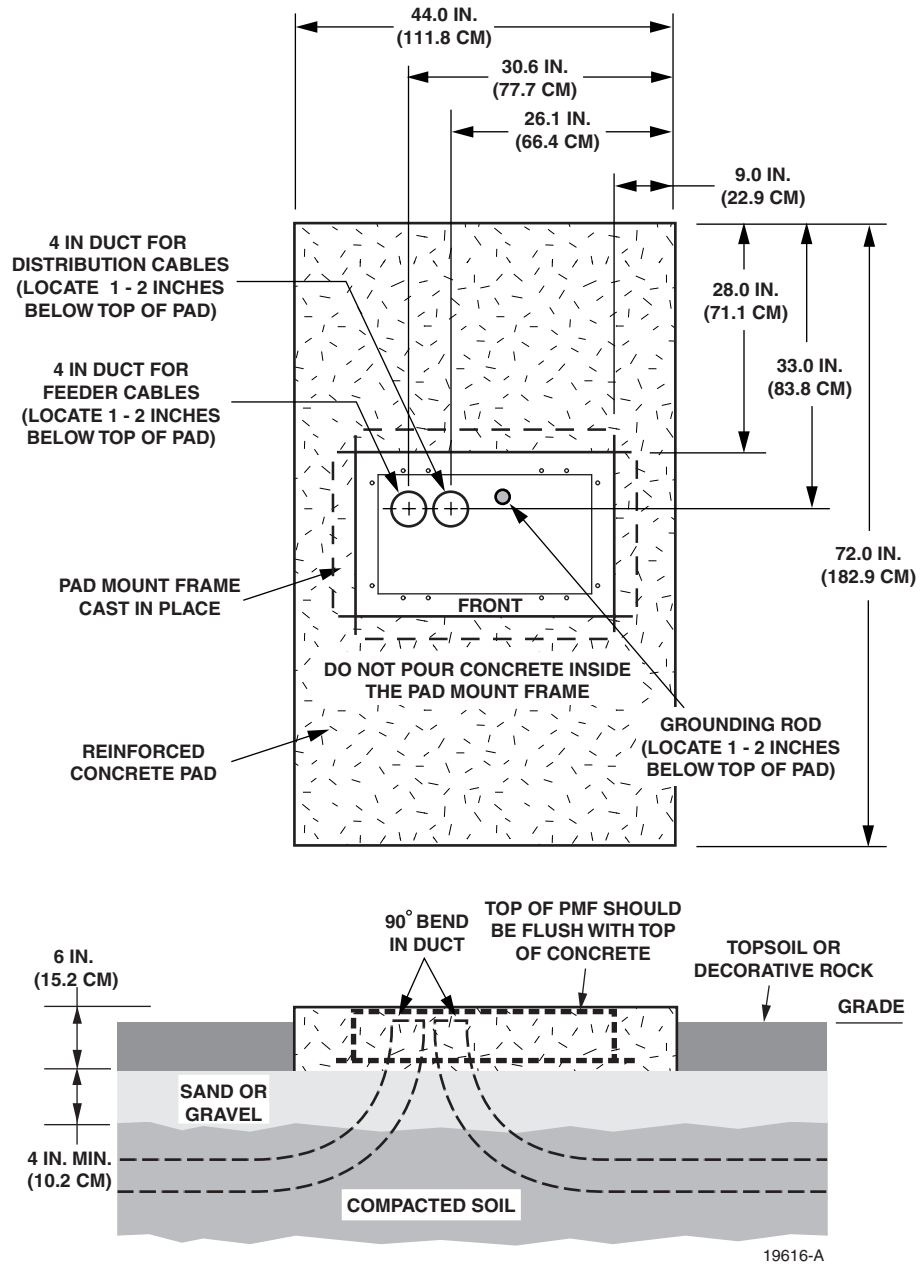

Figure 8. Constructing the Concrete Pad for the ACE-142S/142V Cabinet

4.4 Concrete Pad Construction

Use the following procedure to construct the concrete pad:

1. Build a wood form for the concrete pad using 2 x 6 framing lumber as shown in [Figure 9](#).
 2. Locate the PMF as shown in the construction diagram (see [Figure 8](#)). When installed, the top surface of the PMF must be flush and level with the top of the concrete pad.
- **Note:** Use temporary top framing to keep the top surface of the PMF flush and level with the top of the concrete pad (see [Figure 9](#)).
3. Place reinforcing material inside the form but outside of the PMF.

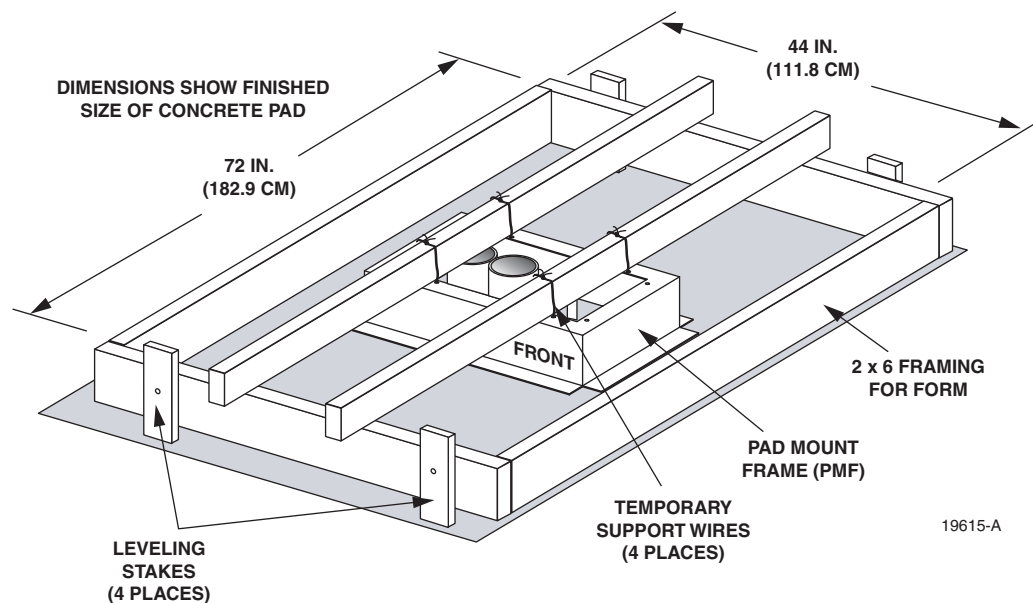

Figure 9. ACE-142S Cabinet Concrete Pad Framing

4. Verify that the PMF and form are level. Depending on the landscaping requirements, the top surface of the concrete pad may be 0 to 3 inches (0 to 7.6 cm) above the final grade. The weld nuts are covered with plugs which must be left in place until the enclosure is mounted.
 5. Pour the concrete to form the pad but do *not* pour concrete into the center area of the PMF.
- **Note:** Allow some concrete to flow under the flanges on the bottom of the PMF so the PMF will be locked in place when the concrete hardens. However, do not allow concrete to fill the center of the PMF. If necessary, partially fill the center of the PMF with sand or gravel to prevent an inflow of concrete.
6. Remove the top framing and the temporary support wires when the concrete is ready to be finished.
 7. Allow concrete to cure before proceeding with the installation.

4.5 Grounding System Installation

Install a grounding system (not provided) that meets all local electrical codes. Check local codes for grounding system installation, use of clamps, wire size, and any other grounding requirements. Typically, #6 AWG copper wire is used for the ground wire. If the grounding system includes a ground rod, install the rod (see [Figure 8](#)) within the PMF opening at the indicated point. When installed, the top of the rod should be located 1 to 2 inches (2.54 to 5.08 cm) **below** the top of the finished concrete pad. Connect the grounding wire to the grounding system. Leave sufficient slack in the grounding wire to allow it to be routed into the cabinet after the cabinet is mounted on the pad.

4.6 Mounting the Cabinet on the Concrete Pad

The following sections provide instructions for mounting the ACE-142S/142V cabinet on the concrete pad. With the ACE-142S cabinet, the distribution cables must be installed after the cabinet is mounted. With the ACE-142V cabinet, the distribution cables are pre-installed in the cabinet by the factory. If mounting an ACE-142S cabinet, refer to [Section 4.6.1](#) for the cabinet mounting procedure. If mounting an ACE-142V cabinet with pre-installed distribution cables, refer to [Section 4.6.2](#) for the cabinet mounting procedure. Use the 216B key tool to un-latch and latch the cabinet doors as needed during the mounting process.



Warning: Use appropriate lifting equipment when moving or installing the cabinet. Do not stand under the cabinet as it is being hoisted into position for installation. A failure of the lifting equipment could result in serious personal injury.

4.6.1 Mounting the ACE-142S Cabinet on a Concrete Pad

Use the following procedures to mount the ACE-142S cabinet on the concrete pad.

1. Remove the plastic plugs that are installed in the threaded corner holes of the PMF and clean off any concrete that may have adhered to the top of the PMF.
- ▶ **Note:** Make sure all remnants of concrete are removed from the PMF prior to mounting the cabinet. It is not necessary to use shims to level or align the cabinet as long as the top surface of the PMF is clean and free of any installation debris.
2. If a ground spacer will not be installed, proceed to step 7. If a ground spacer (accessory) will be installed, align the ends of the left ground spacer section with the ends of the right ground spacer section and then press the two sections together.
3. Place the assembled ground spacer in position for mounting on the PMF as shown in [Figure 10](#).
4. Align the mounting holes in the ground spacer with the mounting holes in the PMF.
5. Secure the ground spacer to the PMF using the four capscrews, four lock washers, and four flat washers provided with the cabinet. Tighten all capscrews securely.
6. Open the rear door of the cabinet and remove the back section of the cabinet bottom cover as described in [Section 5.1](#). Then return to step 7 of this procedure to finish mounting the cabinet.

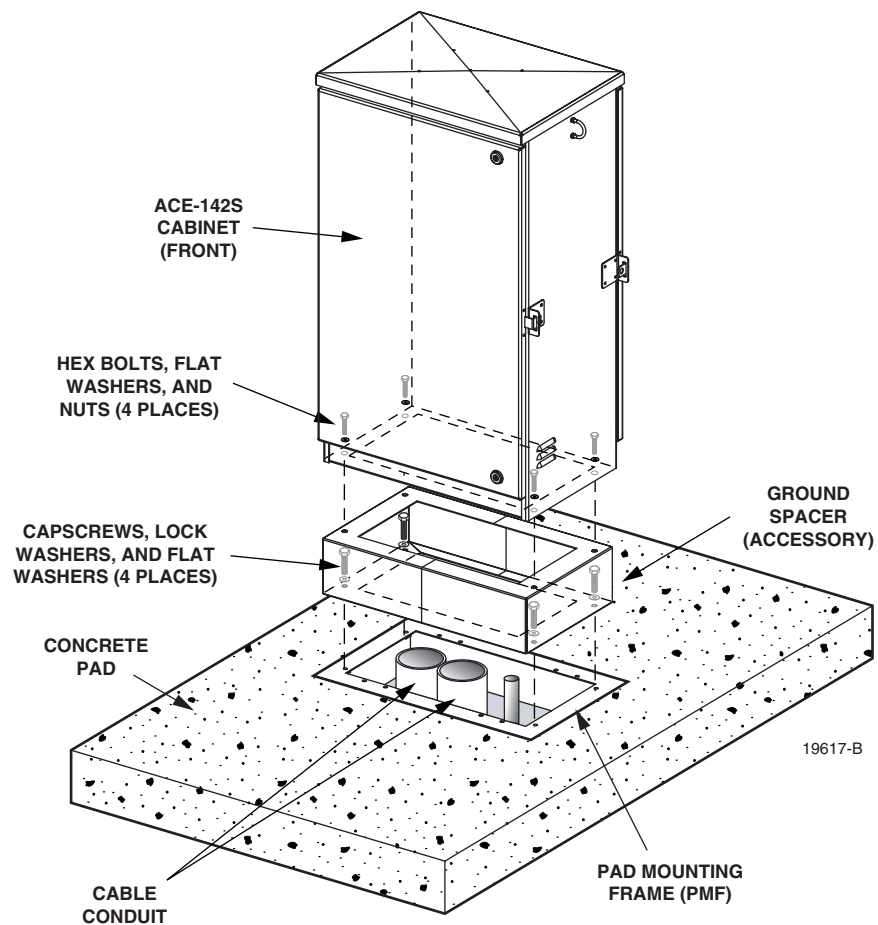

Figure 10. Mounting the ACE-142S Cabinet on the Concrete Pad

7. Using appropriate lifting equipment, hold the cabinet in position for mounting over the ground spacer or PMF.
8. Lower the cabinet onto the ground spacer or PMF and align the mounting holes in the cabinet base with the threaded holes in the spacer or PMF.
9. If the installation includes a ground spacer, secure the cabinet to the spacer using the four hex bolts, four flat washers and four nuts provided with the spacer. If the installation does not include a ground spacer, secure the cabinet to the PMF using the four hex bolts, lock flat washers, and four flat washers provided with the cabinet. Tighten all fasteners securely.

4.6.2 Mounting the ACE-142V Cabinet on a Concrete Pad

Use the following procedures to mount the ACE-142V cabinet on the concrete pad.

1. Remove the plastic plugs that are installed in the threaded corner holes of the PMF and clean off any concrete that may have adhered to the top of the PMF.

- ▶ **Note:** Make sure all remnants of concrete are removed from the PMF prior to mounting the cabinet. It is not necessary to use shims to level or align the cabinet as long as the top surface of the PMF is clean and free of any installation debris.
- 2. If a ground spacer will not be installed, proceed to step 7. If a ground spacer (accessory) will be installed, align the ends of the left ground spacer section with the ends of the right ground spacer section and then press the two sections together.
- 3. Place the assembled ground spacer in position for mounting on the PMF as shown in [Figure 11](#).

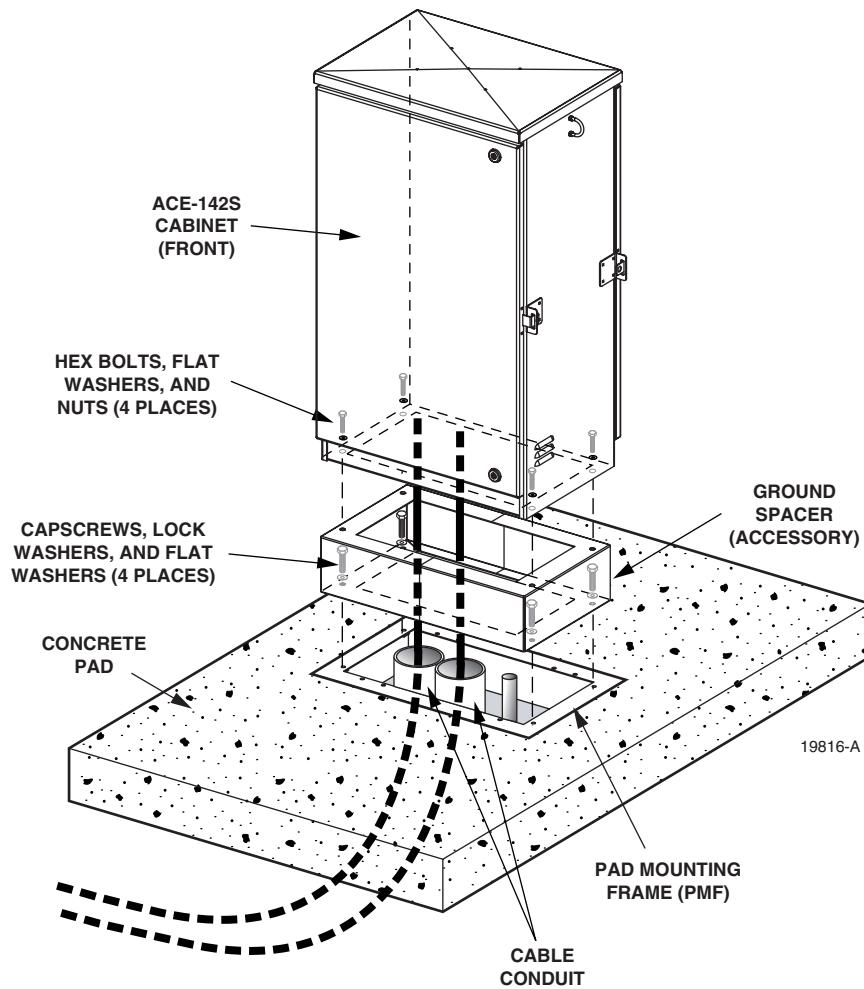

Figure 11. Mounting the ACE-142V Cabinet on the Concrete Pad

- 4. Align the mounting holes in the ground spacer with the mounting holes in the PMF.
- 5. Secure the ground spacer to the PMF using the four capscrews, four lock washers, and four flat washers provided with the cabinet. Tighten all capscrews securely.

6. Open the rear door of the cabinet and remove the back section of the cabinet bottom cover as described in [Section 5.1](#). Then return to step 7 of this procedure to finish mounting the cabinet.
 7. Using appropriate lifting equipment, hold the cabinet in position over the pad (see [Figure 11](#)) so the cabinet is suspended over the rectangular opening in the top of the ground spacer or PMF.
 8. Feed each distribution cable into the appropriate conduit section and route to the splice enclosure (not provided).
- ▶ **Note:** The cables are coiled on spools for shipment. On each spool is a label that lists each fiber subunit within the cable and the connector panels where each subunit is terminated. After the cable is unspooled, label each cable with the corresponding fiber subunit and connector panel designations. In addition, tag or label the stub end of each cable so that the cable can be identified after being routed to the splice enclosure.
- ▶ **Note:** A separate splice enclosure (not provided) is required for splicing the cabinet OSP distribution cables to the system OSP distribution cables.
9. Lower the cabinet onto the ground spacer or PMF and align the mounting holes in the cabinet base with the threaded holes in the spacer or PMF.
 10. If the installation includes a ground spacer, secure the cabinet to the spacer using the four hex bolts, four flat washers and four nuts provided with the spacer. If the installation does not include a ground spacer, secure the cabinet to the PMF using the four hex bolts, lock flat washers, and four flat washers provided with the cabinet. Tighten all fasteners securely.

5 FEEDER CABLE INSTALLATION AND SPLICING

This section describes how to install the OSP feeder cables in the ACE-142S/142V cabinet and how to use the feeder cable splice trays.

5.1 Bottom Cover Removal

The ACE-142S/142V cabinet is equipped with a two-piece bottom cover that prevents moisture and dirt from entering the cabinet through the bottom. The cable-entry section of the bottom cover must be removed to allow installation of the OSP cables. If the bottom cover was removed previously, skip this section and proceed to [Section 5.2](#). Use the following procedure to remove the cable-entry section of the cabinet bottom cover from the cabinet:

1. Open the rear door of the cabinet.
2. Remove the five lock nuts and five flat washers that secure the cable-entry section of the bottom cover to the cabinet as shown in [Figure 12](#). Save the nuts and washers for reuse.
3. Lift up the cable-entry section of the bottom cover and push it toward the front of the cabinet so it will be out of the way when the OSP cables are installed.

► **Note:** Be careful not to damage the gaskets that are attached to the underside of the bottom cover. If the distribution cables are pre-installed, the grommets may be left in place over the cables when the cover is removed.

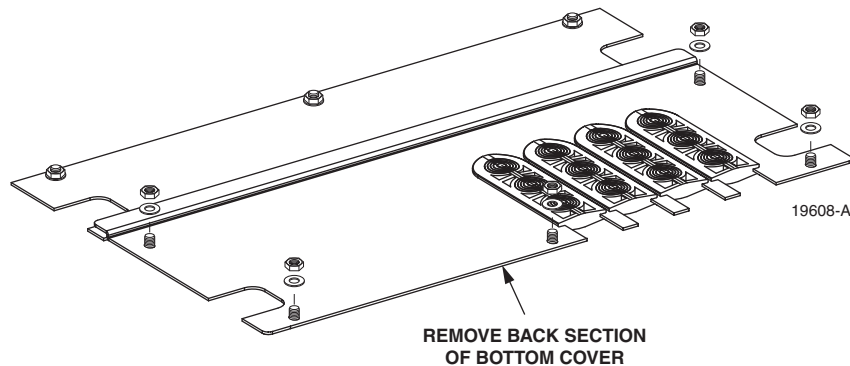

Figure 12. Bottom Cover Cable-Entry Section Removal

5.2 Cabinet Grounding Wire Connection

Prior to mounting the cabinet, a grounding system should have been installed and a grounding wire should have been connected to the grounding system (see [Section 3.5](#) or [Section 4.5](#)). Use the following procedure to attached the grounding wire to the cabinet grounding lug:

1. Locate the grounding wire that was installed prior to mounting the cabinet and pull several feet of slack up and into the cabinet.

2. Attach the grounding wire to the grounding lug as shown in [Figure 13](#). The grounding lug can be used for #6 – #14 AWG wire. Tighten the grounding lug set screw securely.
3. Leave sufficient slack so the grounding wire can be repositioned as needed when the cable entry section of the bottom cover is re-installed.

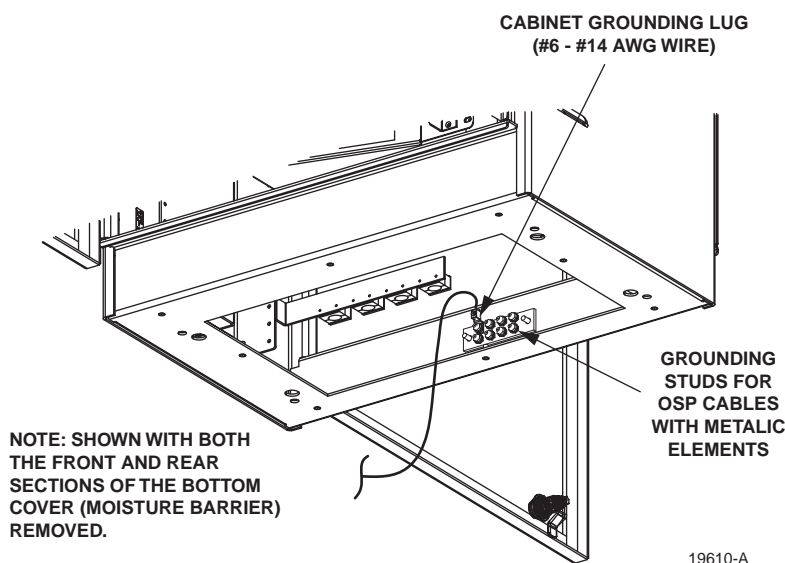

Figure 13. Grounding Wire Connection To Cabinet

5.3 Feeder Cable Installation

The OSP feeder cable enters/exits the ACE-142S/142V cabinet from the bottom. At the entry/exit point to the cabinet, the feeder cable is secured with a clamp. Beyond the clamp, the outer sheath of the cable is removed to expose the optical fibers. The feeder cable is typically a 12- to 24-fiber cable with stranded or ribbon type fiber construction. Moisture blocking and/or grounding kits should be installed (as required by local practice) to protect the exposed optical fibers. From the clamping point, the optical fibers are routed to splice trays for splicing to the splitter input fibers.

- **Note:** If additional splitter modules will be installed in the cabinet as part of the initial installation, complete splitter installation before proceeding with feeder cable installation. Refer to [Section 10](#) for the splitter module installation procedure.

Use the following procedure to install the feeder cable:

1. Route the OSP feeder cable into the cabinet from the bottom. If the cabinet is mounted on a concrete pad, use the duct on the right side.
2. Pull the cable up through the cabinet and strip off 156 inches (396 cm) of the outside cable sheath to expose the fiber subunits.
3. Install moisture-blocking and/or grounding kits as required by local practice. Follow the installation instructions provided with each kit.

- ▶ **Note:** A blocking kit is recommended when installing ribbon cable. The blocking kit includes plastic tubes that protect the fiber ribbons and prevent damage. If a grounding kit is required, strip the cable sheath to the recommended length and install the grounding clamp prior to securing the cable to the cabinet.
4. Three cable clamping positions are provided for securing feeder cables as shown in [Figure 14](#). Select one of the clamping positions as the attachment point for the cable.
- ▶ **Note:** Use the middle cable clamp position first and the top clamp position second when installing the feeder cables. The bottom clamp position is an extra. The bracket for the top row of clamps may be removed if necessary to facilitate cable installation.

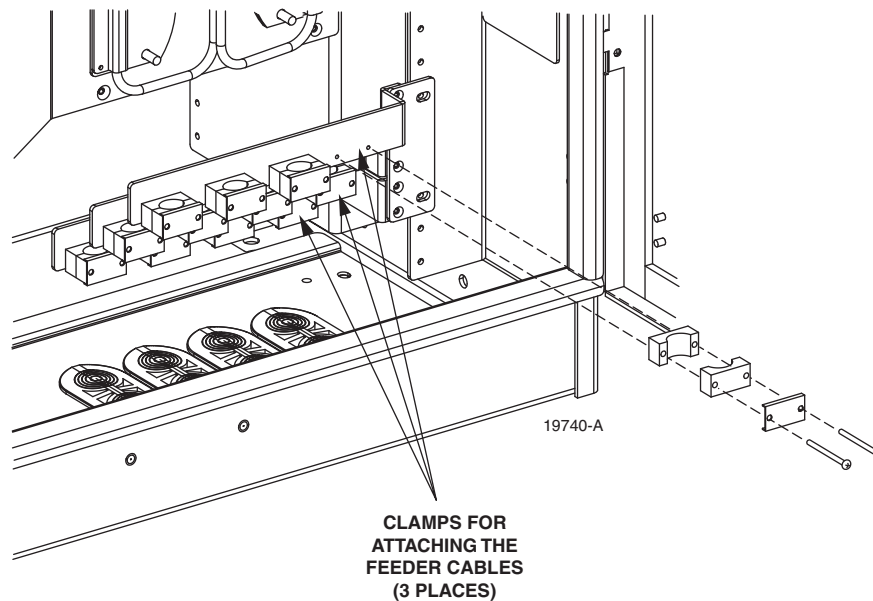

Figure 14. Feeder Cable Clamping Positions

5. Back out the two 2-inch long 6-32 screws that secure the two clamps and cover plate to the cabinet.
6. Assemble the clamps (and grommet if required) on the cable as shown in [Figure 15](#) and then secure the cable to cabinet at the clamping position selected in step 4.
7. If a grounding kit was installed on the cable, attach the cable grounding lead to one of the grounding studs located within the cabinet (see [Figure 13](#)).
8. From the cable clamping location, route the first fiber subunit up the right side of the cabinet as shown in [Figure 16](#).

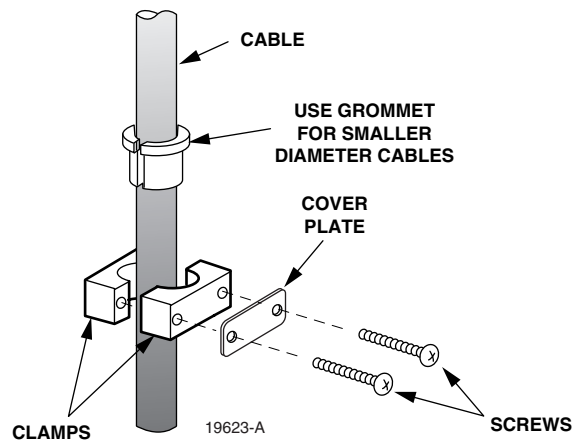

Figure 15. Cable Clamp Assembly for Feeder Cable

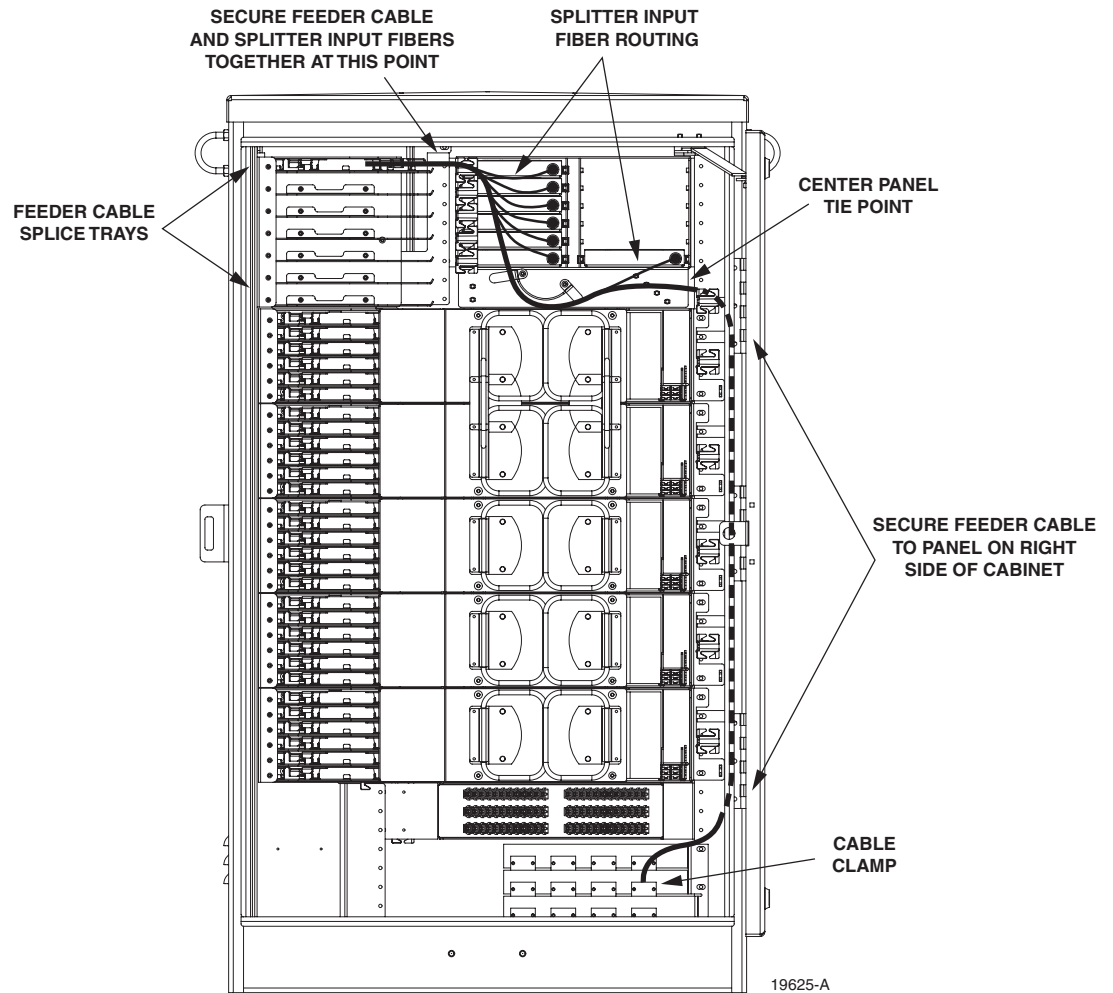

Figure 16. Feeder Cable Fibers Routed To Splice Trays

9. Secure the fiber subunit to the panel on the right side of the cabinet using the tie points provided.
10. From the right side of the cabinet, route the fiber subunit to the center panel located just below the splitter modules and secure using the tie point provided.
11. From the center panel, route the fiber subunit to the splice wheel used for the splitter module input fibers following the same path as the splitter module input fibers.
12. Repeat steps 1–11 for each feeder cable subunit and each additional feeder cable.

5.4 Feeder Cable and Splitter Input Fiber Splicing

The OSP feeder cable fibers must be spliced to the splitter input fibers. Up to twelve splitter modules may be mounted in the cabinet so that a maximum of twelve feeder splices may be required. Round splice trays are used for splicing and seven splice tray mounting slots are provided. Each splice tray can hold up to 12 splices. Use the following procedure to install the feeder cable fibers and splitter input fibers in each splice tray in preparation for splicing:

1. The input fibers from each splitter are routed to a splice tray located on the top left side of the cabinet. Locate the splice tray that was used for the splitter input fibers and remove that tray from the cabinet.
 2. Uncoil the splitter input fibers from the splice tray.
- **Note:** The splitter input fibers are temporarily coiled around the splice tray for storage.
3. Secure the splitter input fibers and the feeder cable fiber subunit together at the point where the two come together before entering the splice tray (see [Figure 16](#)). Adjust slack as necessary to prevent binding.
 4. Check the routing of the splitter input fibers and adjust as needed to relieve tension or remove excess slack.
 5. Starting at the common tie point within the cabinet, measure and mark the fiber cut lengths for the splitter input fibers and the feeder cable fiber subunits as shown in [Figure 17](#).

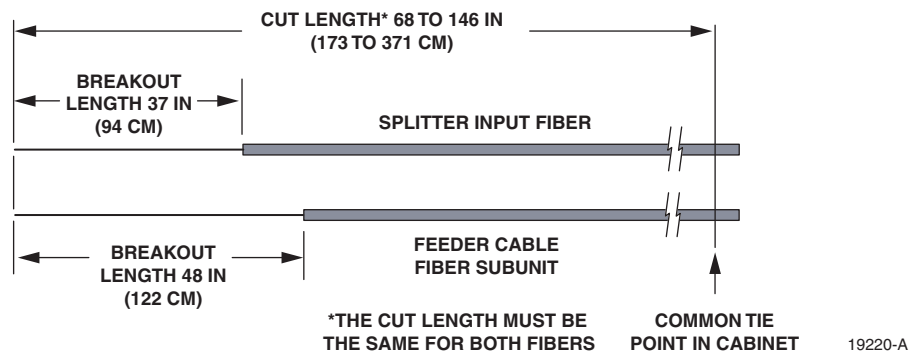

Figure 17. Cut Length and Breakout Length for Feeder Cable and Splitter Input Fiber

6. Cut both the splitter input fibers and the feeder cable fiber subunit at the cut length mark. Make sure that the splitter input fibers and the feeder cable fiber subunit are of equal length and the overall length is within the range specified.
7. Starting at the cut end, measure backward and mark the break-out lengths for the feeder cable fibers and the splitter input fibers.
8. Starting at the breakout mark, remove the protective jackets to expose the feeder cable fibers (may be stranded or ribbon fibers) and the splitter input fibers.
9. Install the splitter input fibers and the feeder cable fibers in the splice tray and complete all splices per local practice. Refer to [Section 7](#) for information on how to use the round splice trays and then return to Step 10 to continue this procedure.
10. After splicing is completed, the splice tray cover replaced, and the excess slack rolled up, insert the splice tray into the designated mounting slot.
11. Repeat this procedure for each feeder cable fiber subunit.
12. Designation labels, shown in [Figure 18](#) and [Figure 19](#), are provided on the front door of the cabinet for recording splitter module information. For each splitter, indicate the splice tray number, feeder cable fiber number, splitter module number, and service information.

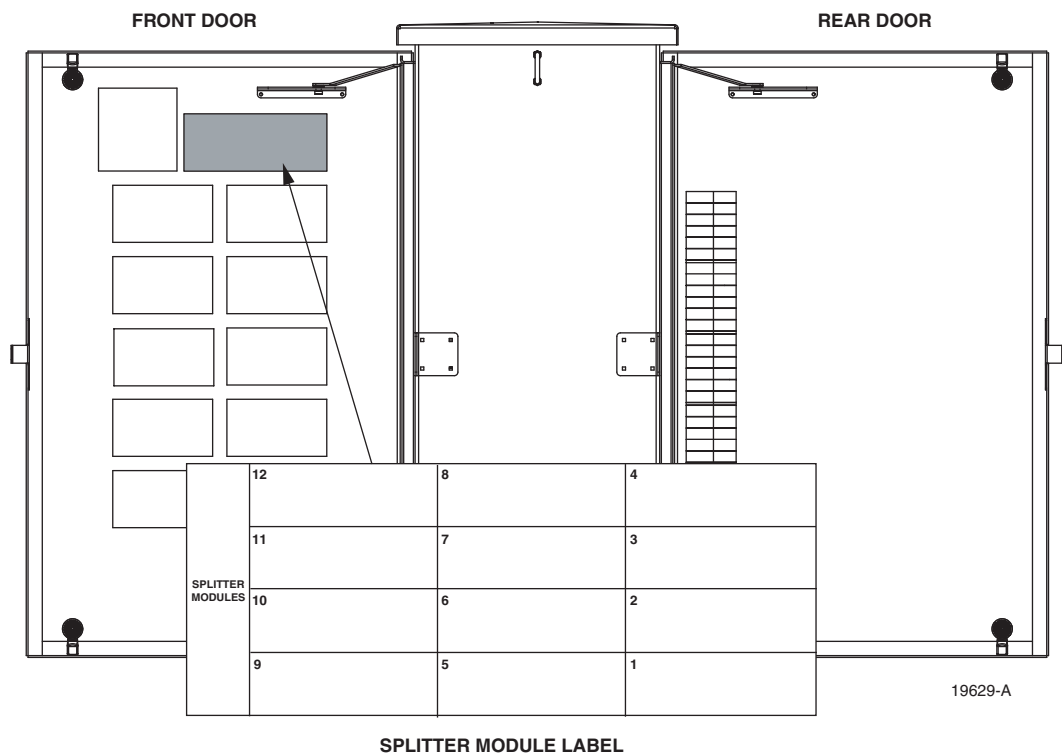

Figure 18. Splitter Module Designation Label - Type 1

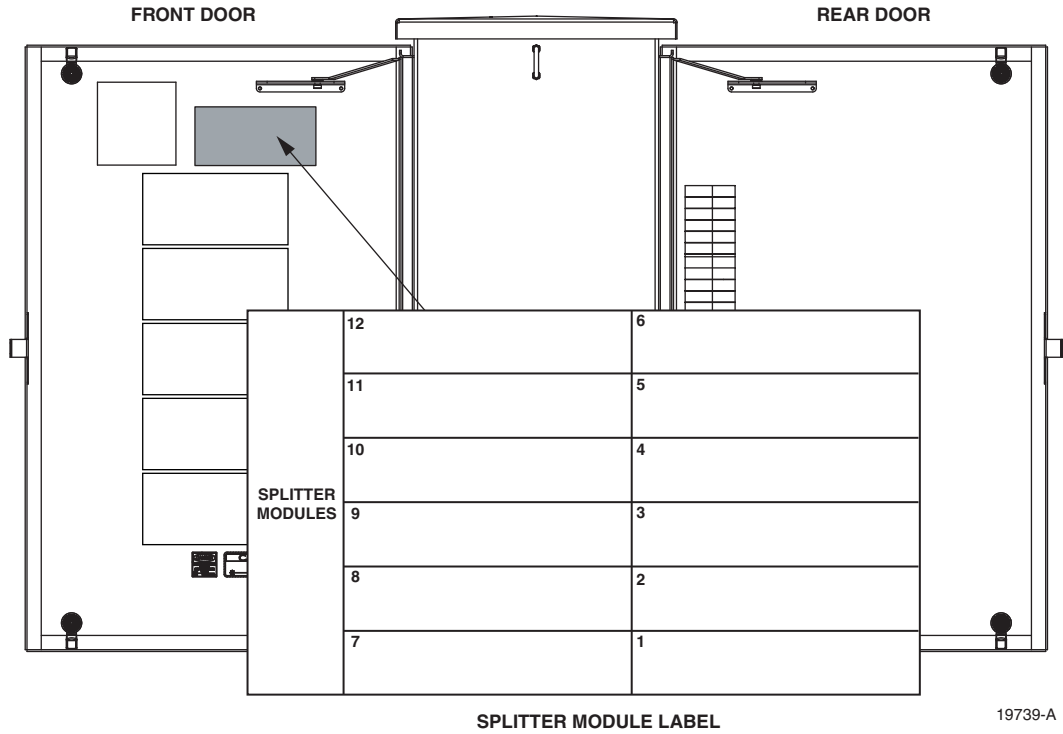

Figure 19. Splitter Module Designation Label - Type 2

6 DISTRIBUTION CABLE INSTALLATION AND SPLICING

This section describes how to install the OSP distribution cables in the ACE-142S/142V cabinet and how to use the distribution cable splice trays. If the cabinet is equipped with pre-installed distribution cables, refer to [Section 6.2](#) for the bottom cover installation procedure.

6.1 Distribution Cable Installation

The OSP distribution cables enter the ACE-142S/142V cabinet from the bottom. At the entry/exit point to the cabinet, each distribution cable is secured with a clamp. Beyond the clamp, the outer sheath of the cable is removed to expose the optical fibers. Moisture blocking, grounding, and fanout kits must be installed (as required by local practice) to protect the exposed optical fibers. The OSP distribution cable fiber count may be any multiple of 72 (depending on the number of connector panels) with stranded or ribbon type fiber construction. From the clamping point, the optical fibers are routed to the splice trays for splicing to the connector panel pigtails.

Use the following procedure to install the distribution cable:

1. Route the OSP distribution cable into the cabinet from the bottom. If the cabinet is mounted on a concrete pad, use the duct on the left side.
2. Pull the cable up through the cabinet and strip off 156 inches (396 cm) of the outside cable sheath to expose the fiber subunits.
3. Install moisture-blocking, fanout, and grounding kits as required by local practice. Follow the installation instructions provided with each kit.



Caution: A fanout kit is required when installing ribbon cable. The fanout kit includes plastic tubes that protect the fiber ribbons and prevent damage.

4. Nine cable clamping positions are provided near the center of the cabinet as shown in [Figure 20](#). Select one of the clamping positions as the attachment point for the cable.

► **Note:** Use the middle cable clamp positions first and the top clamp positions second when installing the distribution cables. The bottom clamp positions are extra. The bracket for the top row of clamps may be removed if necessary to facilitate cable installation.

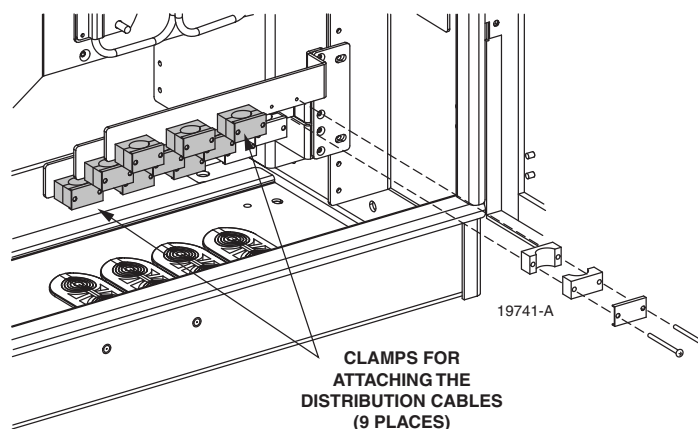

Figure 20. Distribution Cable Clamping Positions

5. Back out the two 2-inch long 6-32 screws that secure the two clamps and cover plate to the cabinet.
6. Assemble the clamps (and grommet if required) on the cable as shown in [Figure 21](#) and then secure the cable to cabinet at the clamping position selected in step 4.

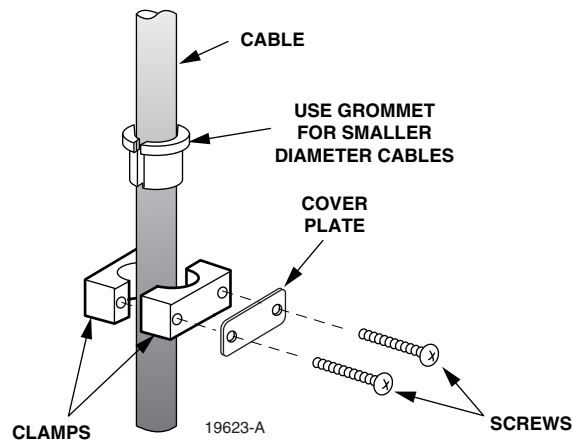

Figure 21. Cable Clamp Assembly for Distribution Cable

7. If a grounding kit was installed on the cable, attach the cable grounding lead to one of the grounding studs located within the cabinet (see [Figure 13](#)).
 8. Repeat steps 1 through 7 for each additional distribution cable.
 9. From the cable clamping location, route the first six distribution cable fiber subunits up the right side of the cabinet as shown in [Figure 22](#).
 10. Secure the subunits to the panel on the right side of the cabinet using the tie points provided.
 11. Use a Phillips screwdriver to remove the four screws that secure the handle assembly to the back of connector panel #1 (top panel) as shown in [Figure 23](#). Save each screw for reuse.
 12. Remove the handle assembly from the back of connector panel #1.
 13. Route the first six fiber subunits across the back of connector panel #1 to splice trays 1–6 located on the left side of the cabinet.
- **Note:** The splice trays are numbered 1 through 30 starting with the top splice tray in connector panel #1. Route all distribution cable fibers to the splice trays starting with the top tray and working towards the bottom tray.
14. Secure each fiber subunit to the back of the connector panel using the tie points indicated in [Figure 22](#).
 15. Use the same basic procedure specified in steps 8 through 14 for routing the remaining distribution cable fiber subunits to the remaining distribution cable splice trays. Repeat the routing process until every fiber subunit is routed to a splice tray.

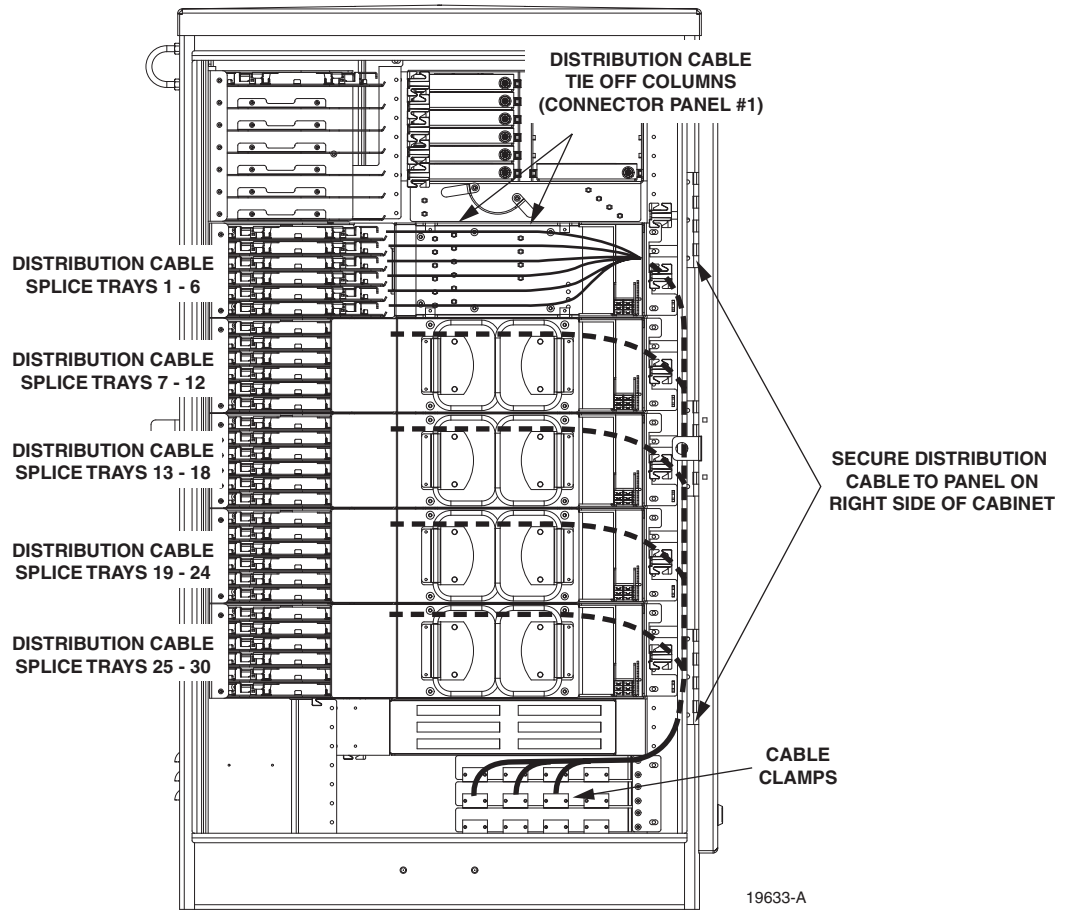

Figure 22. Distribution Cable Fibers Routed to Splice Trays

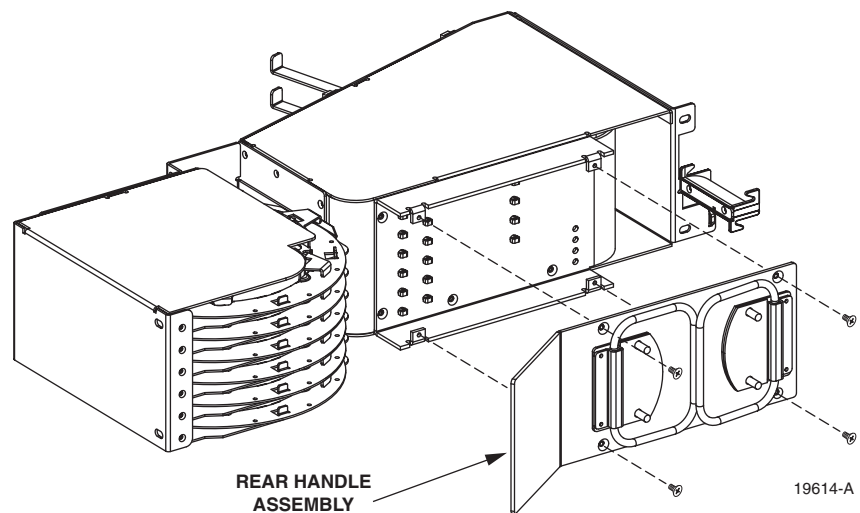

Figure 23. Rear Handle Assembly Removal and Installation

6.2 Bottom Cover Installation

The cable-entry section of the bottom cover must be replaced following installation of the grounding wire, feeder cable(s), and distribution cable(s). Use the following procedure to replace the cable-entry section of the bottom cover:

1. Locate the bottom cover (cable-entry section) that was removed from the cabinet in step 2 of [Section 5.1](#).
2. Determine which grommets will be used for sealing the cable entry/exit points and remove those grommets from their mounting slots in the bottom cover.
3. Using a utility knife, cut through the slit that runs lengthwise down the center of each grommet as shown in [Figure 24](#).
4. Remove enough cable cutout sections from each grommet to accommodate the size and number of cables that will pass through the grommet.

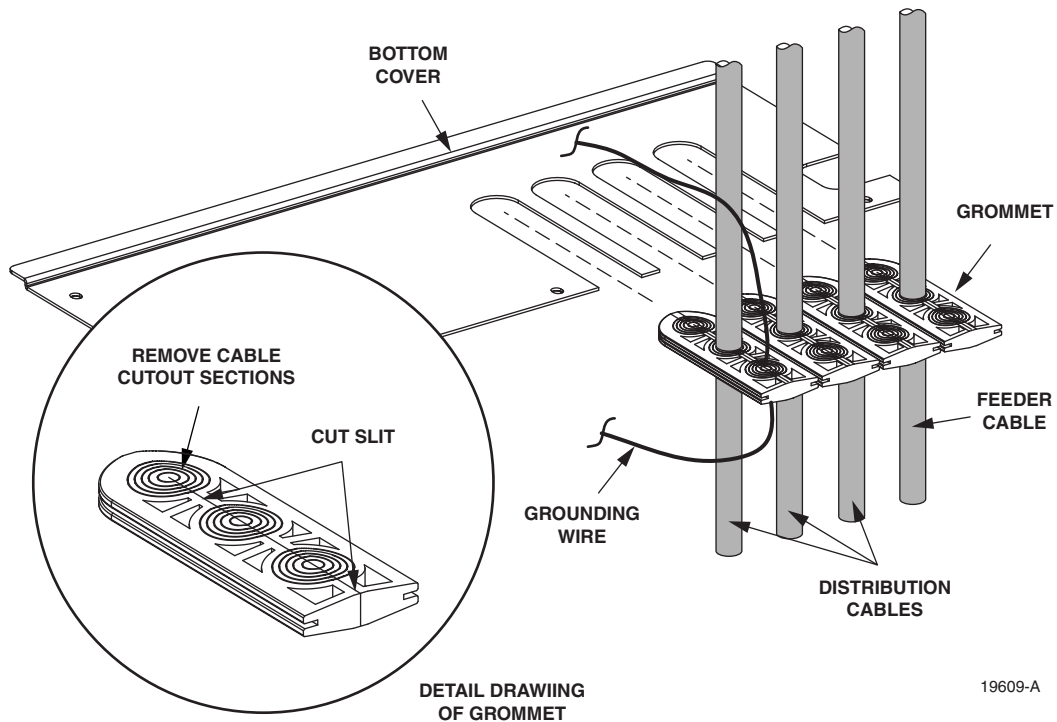

Figure 24. Bottom Cover Installation

5. Install the grommets on the cables.

► **Note:** More than one cable may have to pass through the same grommet.

6. Insert the grommets into their respective mounting slots in the bottom cover.

7. Slide the bottom cover down to the bottom of the cabinet.
8. Align the five holes in the bottom cover with the five studs around the edge of the cabinet.
9. Install a flat washer and lock nut (removed in step 1 of [Section 5.1](#)) on each stud and tighten securely.

6.3 Distribution Cable and Connector Panel Pigtail Splicing

The distribution cable must be spliced to the connector panel pigtails. Up to five 72-port connector panels may be mounted in the cabinet which requires a maximum of 360 distribution splices. Round splice trays are used for splicing and six splice tray mounting slots are provided per panel. This equates to a maximum of 30 splice trays when five connector panels are installed. Each splice tray can hold up to 12 splices. Use the following procedure to install the distribution cable fibers and the connector panel pigtails in the splice tray in preparation for splicing:

1. Locate splice tray #1 (on the left side) and remove that tray from the cabinet.
- **Note:** The pigtails from each connector panel are grouped into six 12-fiber subunits. Each pigtail subunit is routed to a splice tray located on the left side of the cabinet. The splice trays are numbered consecutively 1 through 30 starting with at the top. The subunit, port, fiber, and splice tray designations for each connector panel are shown in [Table 5](#).
2. Uncoil the connector panel pigtail subunit from the splice tray.
- **Note:** Each connector panel pigtail subunit is temporarily coiled around a splice tray for storage.
3. Starting at the last column (left side) of tie points on the rear side of the connector panel, measure and mark the fiber cut lengths for the distribution cable fiber subunits and the connector panel fiber subunits as shown in [Figure 25](#).

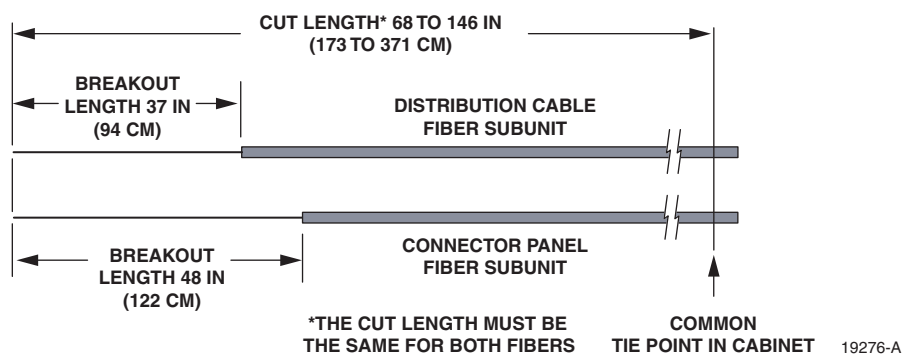

Figure 25. Cut Length and Breakout Length for Distribution Cable and Connector Panel Fibers

4. Cut both the distribution cable fiber subunit and the connector panel pigtail subunit at the cut length mark. Make sure that the distribution cable fiber subunit and the connector panel pigtail subunit are of equal length and the overall length is within the range specified.

Table 5. Connector Panel Sub Unit, Port, Fiber, and Splice Tray Designations

SUB UNIT	PORT	FIBER	SPLICE TRAY	SUB UNIT	PORT	FIBER	SPLICE TRAY		
1	1	1 (Blue)	Tray 1 if Panel 1	4	37	1 (Blue)	Tray 4 if Panel 1		
	2	2 (Orange)	Tray 7 if Panel 2		38	2 (Orange)	Tray 10 if Panel 2		
	3	3 (Green)			39	3 (Green)			
	4	4 (Brown)	Tray 13 if Panel 3		40	4 (Brown)	Tray 16 if Panel 3		
	5	5 (Slate)	Tray 19 if Panel 4		41	5 (Slate)	Tray 22 if Panel 4		
	6	6 (White)			42	6 (White)			
	7	7 (Red)	Tray 25 if Panel 5		43	7 (Red)	Tray 28 if Panel 5		
	8	8 (Black)			44	8 (Black)			
	9	9 (Yellow)			45	9 (Yellow)			
	10	10 (Violet)			46	10 (Violet)			
	11	11 (Rose)			47	11 (Rose)			
	12	12 (Aqua)			48	12 (Aqua)			
2	13	1 (Blue)		Tray 2 if Panel 1	5	49		1 (Blue)	Tray 5 if Panel 1
	14	2 (Orange)		Tray 8 if Panel 2		50		2 (Orange)	Tray 11 if Panel 2
	15	3 (Green)	51			3 (Green)			
	16	4 (Brown)	Tray 14 if Panel 3	52		4 (Brown)	Tray 17 if Panel 3		
	17	5 (Slate)	Tray 20 if Panel 4	53		5 (Slate)	Tray 23 if Panel 4		
	18	6 (White)		54		6 (White)			
	19	7 (Red)	Tray 26 if Panel 5	55		7 (Red)	Tray 29 if Panel 5		
	20	8 (Black)		56		8 (Black)			
	21	9 (Yellow)		57		9 (Yellow)			
	22	10 (Violet)		58		10 (Violet)			
	23	11 (Rose)		59		11 (Rose)			
	24	12 (Aqua)		60		12 (Aqua)			
3	25	1 (Blue)		Tray 3 if Panel 1	6	61		1 (Blue)	Tray 6 if Panel 1
	26	2 (Orange)		Tray 9 if Panel 2		62		2 (Orange)	Tray 12 if Panel 2
	27	3 (Green)	63			3 (Green)			
	28	4 (Brown)	Tray 15 if Panel 3	64		4 (Brown)	Tray 18 if Panel 3		
	29	5 (Slate)	Tray 21 if Panel 4	65		5 (Slate)	Tray 24 if Panel 4		
	30	6 (White)		66		6 (White)			
	31	7 (Red)	Tray 27 if Panel 5	67		7 (Red)	Tray 30 if Panel 5		
	32	8 (Black)		68		8 (Black)			
	33	9 (Yellow)		69		9 (Yellow)			
	34	10 (Violet)		70		10 (Violet)			
	35	11 (Rose)		71		11 (Rose)			
	36	12 (Aqua)		72		12 (Aqua)			

5. Starting at the cut end, measure backward and mark the break-out lengths for the distribution cable fibers and the connector panel fibers.
6. Starting at the breakout mark, remove the protective jackets to expose the distribution cable fibers (may be stranded or ribbon fibers) and the connector panel pigtail fibers.
7. Install the connector panel pigtail subunit and the distribution cable fiber subunit in the splice tray and complete all splices per local practice. Refer to [Section 7](#) for details and then return to Step 8 to continue this procedure.
8. After splicing is completed, the splice tray cover replaced, and the excess slack rolled up, insert the splice tray into the designated mounting slot.
9. Repeat this procedure for each connector panel pigtail subunit.
10. When all splices have been completed, re-install the rear handle assembly on the back of each connector panel (see [Figure 23](#)).
11. Connector panel designation labels, shown in [Figure 26](#) and [Figure 27](#), are provided on the front door of the cabinet for recording subscriber information. For each connector panel, indicate the subscriber address and service information and the fiber and cable number if not specified. Splice tray designation labels, shown in [Figure 28](#), are provided on the rear door of the cabinet for recording distribution cable information. For each splice tray, indicate the distribution cable and subunit number.

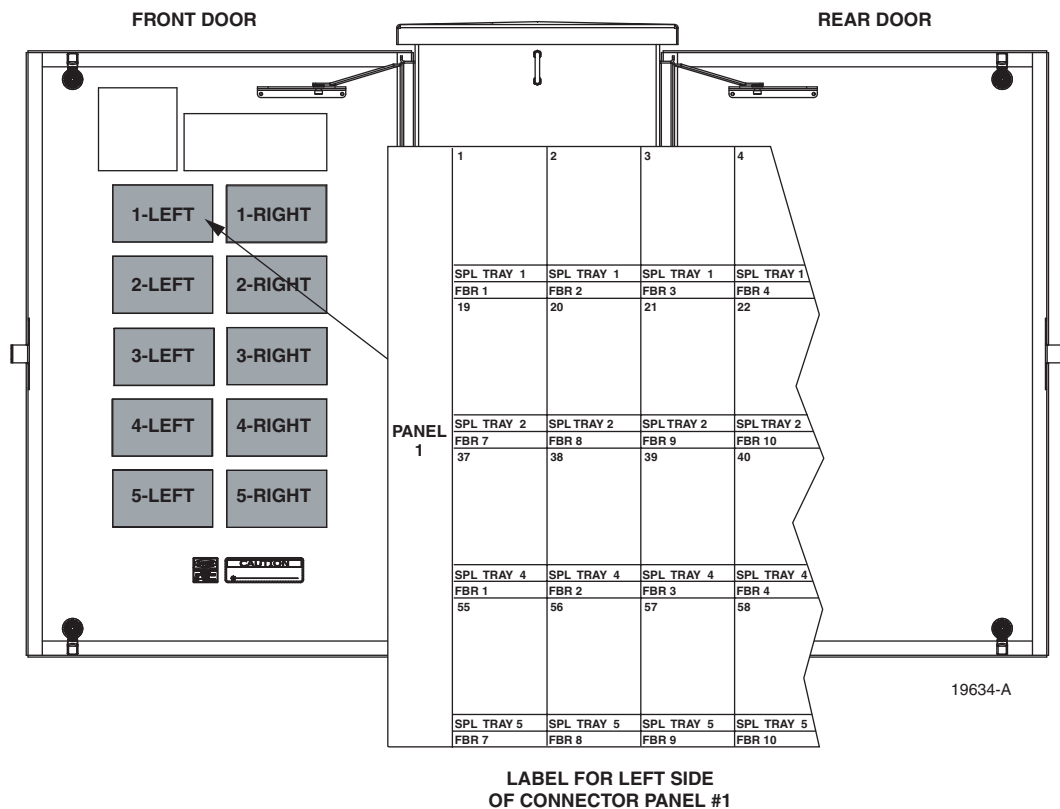

Figure 26. Connector Panel Designation Label - Type 1

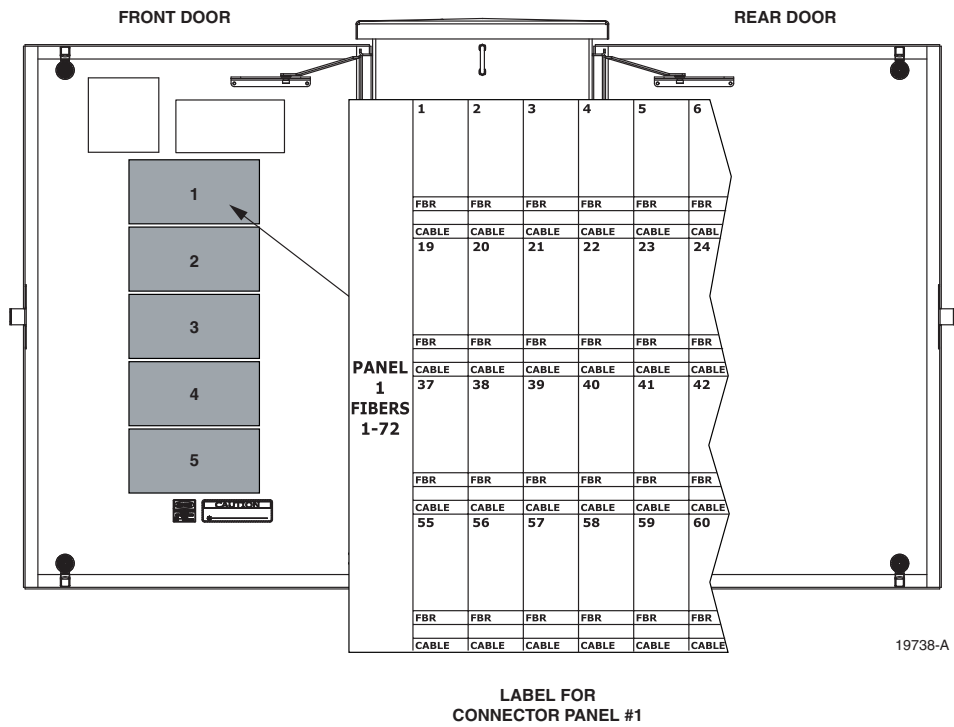

Figure 27. Connector Panel Designation Label - Type 2

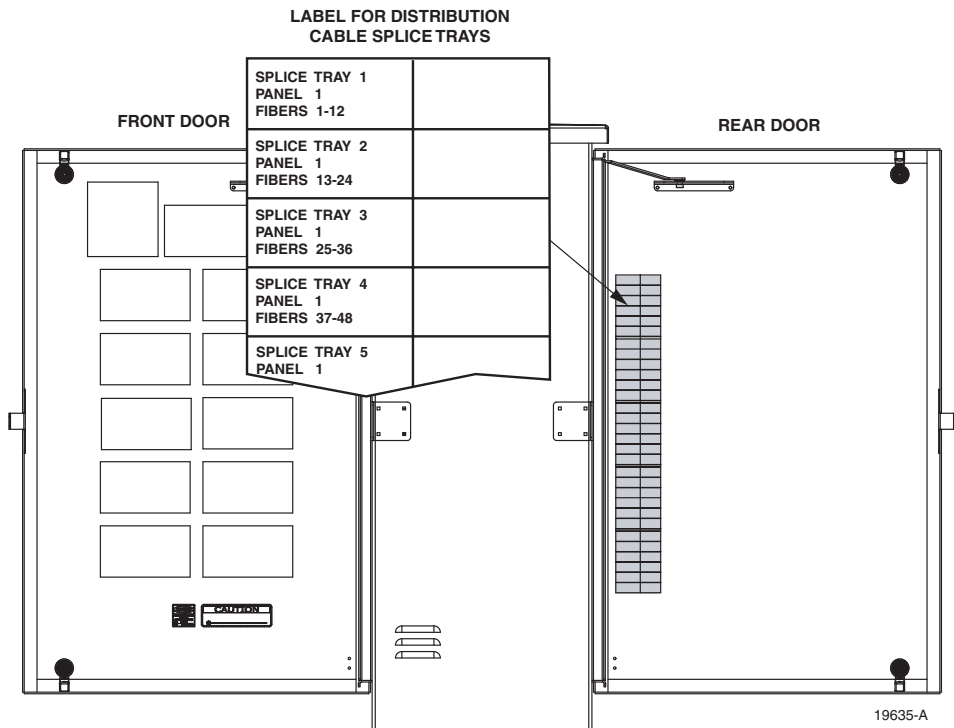

Figure 28. Splice Tray Designation Labels

7 GUIDELINES FOR USING ROUND SPLICE TRAYS

This section provides guidelines for using the round splice trays that are provided with the ACE-142S/142V cabinet. Use the following procedure for installing the fibers in the tray:

1. Remove the top and bottom covers from the splice tray.
2. Secure **subunit A** to the splice tray at the points shown in [Figure 29](#).

► **Note:** If installing the feeder cable, subunit A is the feeder cable subunit. If installing the distribution cable, subunit A is the connector panel pigtail subunit.

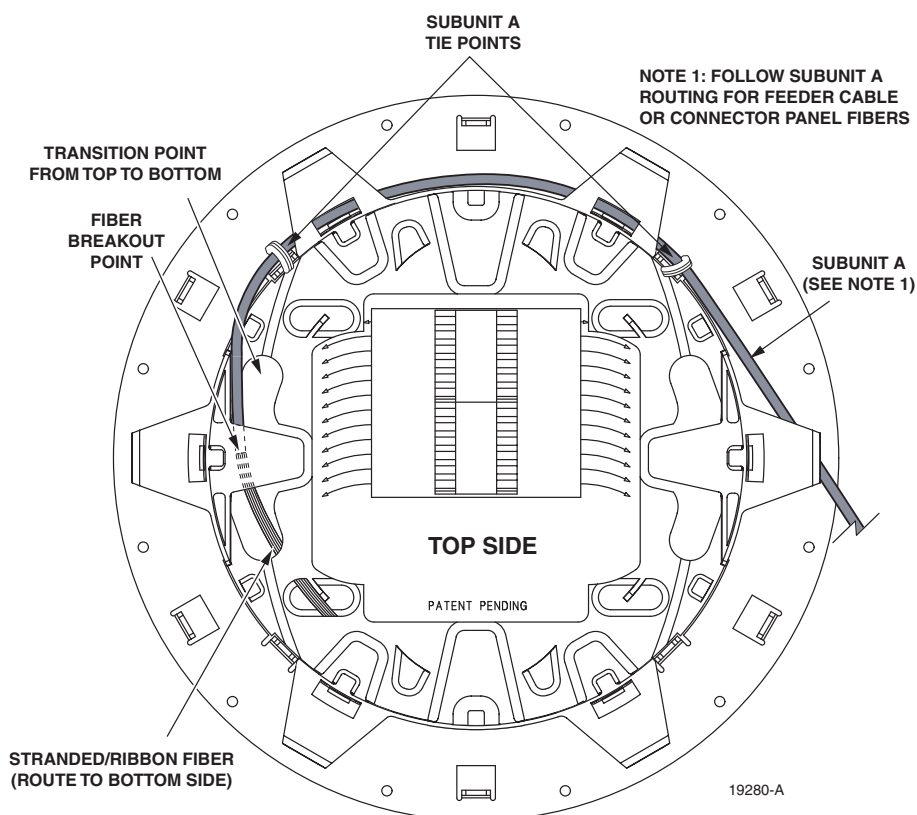

Figure 29. Subunit A Tie Points

3. Insert the breakout fibers through the opening where the fibers transition from the top to the bottom of the splice tray (see [Figure 29](#)).
4. Adjust subunit A so the fiber breakout is positioned at the transition opening.
5. Turn the tray over and continue routing the breakout fibers around the spools as shown in [Figure 30](#) and then back to the top side of the splice tray.

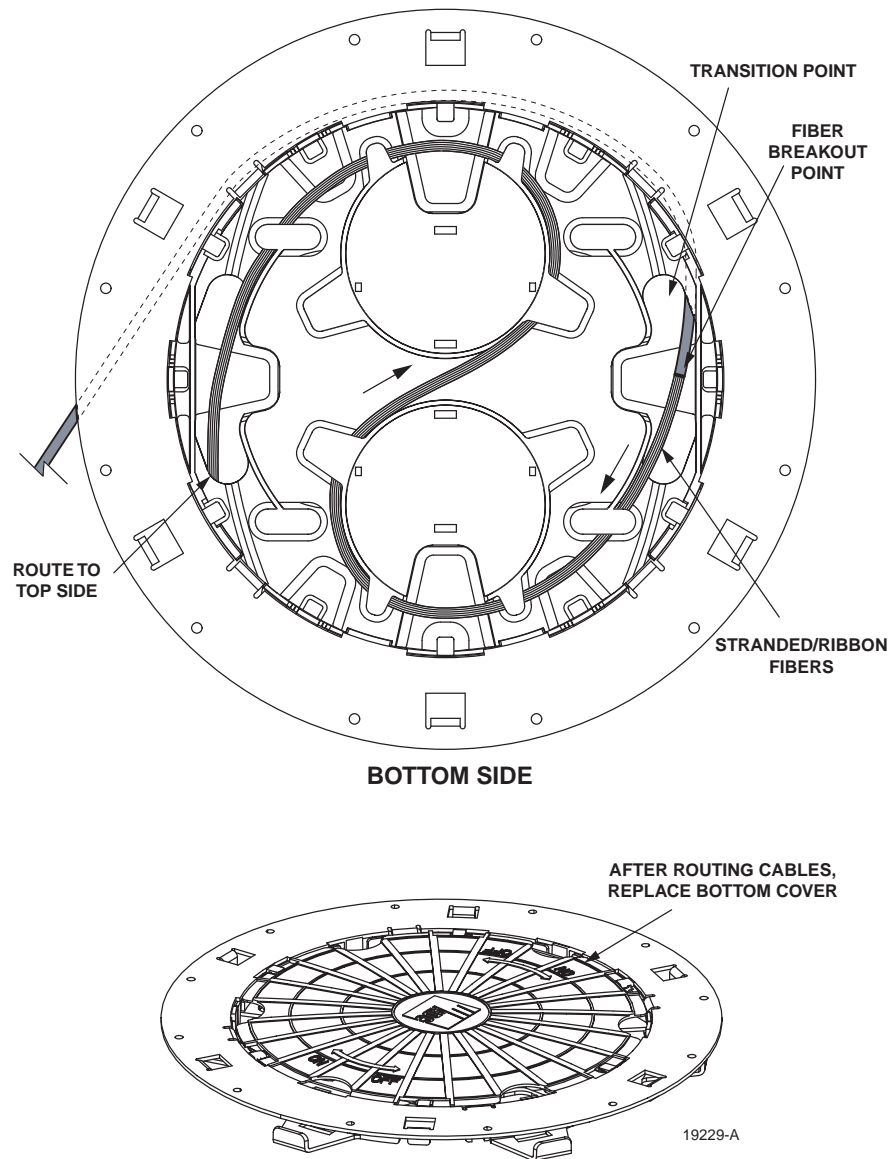

Figure 30. Routing Subunit A Around Back Side of Splice Tray

6. Replace the splice tray bottom cover and then turn the tray over to the top side.
7. Route the breakout fibers at least 1.5 times around the inside of the tray making the loop as large as possible to ensure maximum fiber storage as shown in [Figure 31](#).

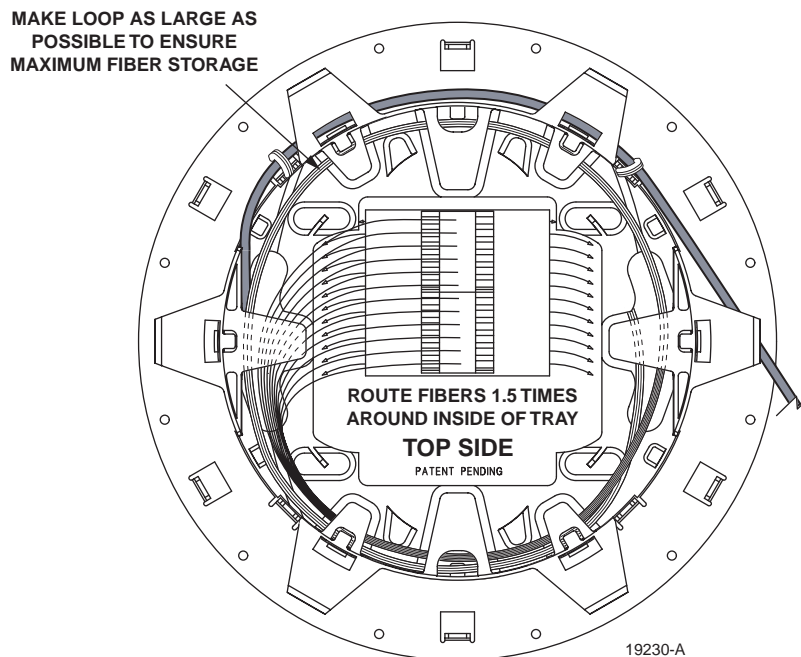

Figure 31. Routing Subunit A Around Front Side of Splice Tray

8. Secure **subunit B** to the splice tray at the points shown in [Figure 32](#). If multiple fibers are being installed, route all fibers simultaneously.
- ▶ **Note:** If installing the feeder cable, subunit B is the splitter input fiber(s). If installing the distribution cable, subunit B is the distribution cable subunit.
9. Adjust subunit B so the fiber breakout is positioned at the point shown (see [Figure 32](#)).
10. Route the breakout fibers at least two times around the inside of the tray making the loop as large as possible to ensure maximum fiber storage.
11. Splice the subunit A fibers to the subunit B fibers as specified by local policies and procedures.
12. Replace the splice tray top cover and then turn the splice tray in a clockwise direction to roll up the excess slack.
13. Return to step 10 in [Section 5.4](#) or step 8 in [Section 6.3](#) to complete the corresponding OSP cable installation procedure.

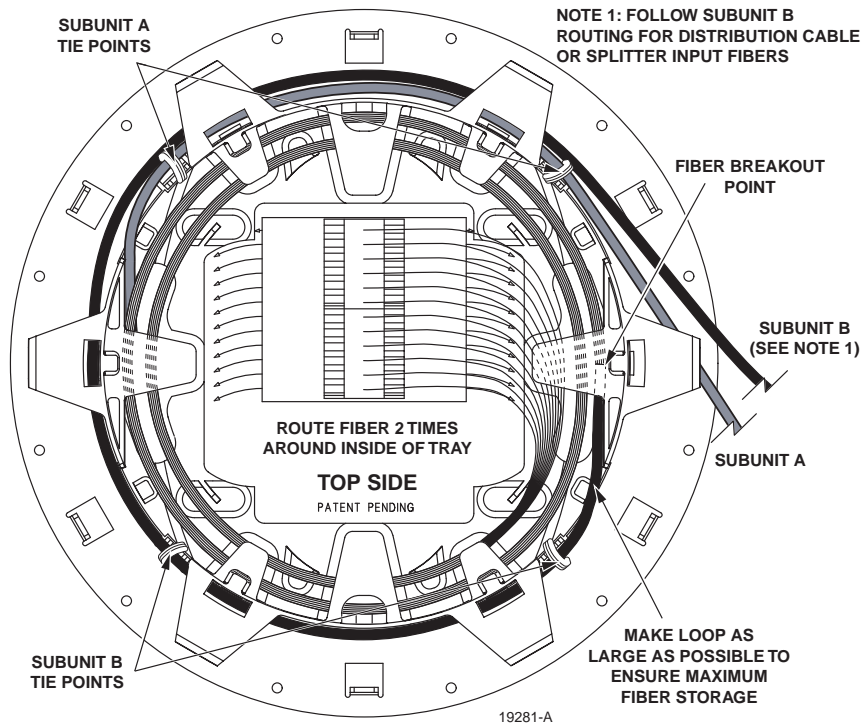

Figure 32. Routing Subunit B Around Front Side of Splice Tray

8 PRE-INSTALLED DISTRIBUTION CABLE CONFIGURATION

ACE-142V cabinets are equipped with pre-installed distribution cables that enter/exit the cabinet from the bottom. At the entry/exit points, each cable is secured with a clamp. Beyond the clamp, the outer sheath of each cable is removed and the fibers are broken out into subunits. Each subunit is fanned out into twelve individual fibers and each fiber is terminated with a connector. The fiber subunits are routed to the connector panels where each fiber is connected to a bulkhead adapter.

Each connector panel can accommodate six 12-fiber subunits which equals 72 fiber ports per panel. Each distribution cable typically has a fiber count that is a multiple of 72 to correspond with the number of ports provided by each connector panel. Depending on the option ordered, cabinets may be equipped with up to nine distribution cables. A drawing is provided with each ACE-142V cabinet that indicates the connector panel and optical port assignments for the fibers within each distribution cable. Refer to this drawing when splicing to determine the terminating port for each fiber within each cable. A diagram of a typical distribution cable configuration is shown in [Figure 33](#).

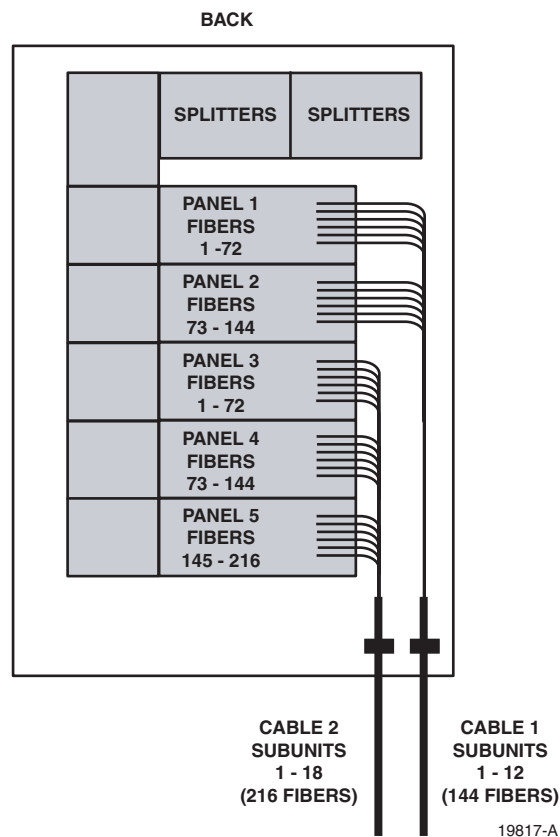

Figure 33. Pre-Installed Distribution Cable - Typical Configuration

9 CONNECTOR PANEL INSTALLATION

The ACE-142S/142V cabinet can accommodate up to five 72-port connector panels which will provide a total of 360 distribution ports. If the cabinet is not pre-loaded with five connector panels, then additional connector panels and round splice trays may be installed as needed. Use the following procedure to install additional connector panels in the cabinet:

1. Position the connector panel in the next available mounting space within the cabinet as shown in [Figure 34](#).
2. Secure the connector panel to the cabinet using the four machine screws provided.

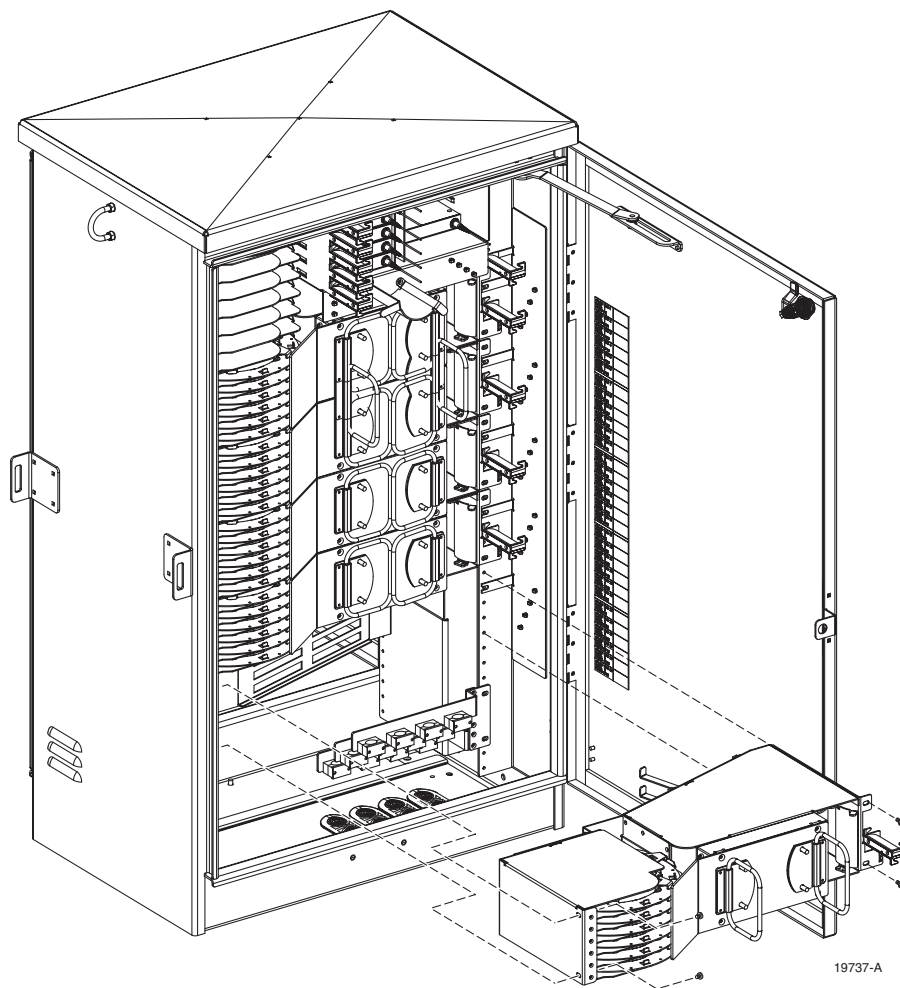

Figure 34. Connector Panel Installation

10 SPLITTER MODULE INSTALLATION

The ACE-142S/142V cabinet can accommodate up to twelve 1x8 or 1x32 splitter modules. The cabinet can support a maximum of 360 output ports for distribution. Use the following procedure to install additional splitters in the cabinet:

1. Install the splitter module in the next available mounting position as shown in [Figure 35](#).
- ▶ **Note:** Install splitters in the order shown in [Figure 35](#), beginning on the right side of the splitter compartment.
2. Route the splitter output fibers to the connector storage panel or to the designated customer port. Refer to [Section 11](#) for the routing procedure.
3. Route the splitter input fiber to the designated splice tray at the back of the cabinet as shown in [Figure 36](#). Up to 12 fibers may be spliced within each splice tray.

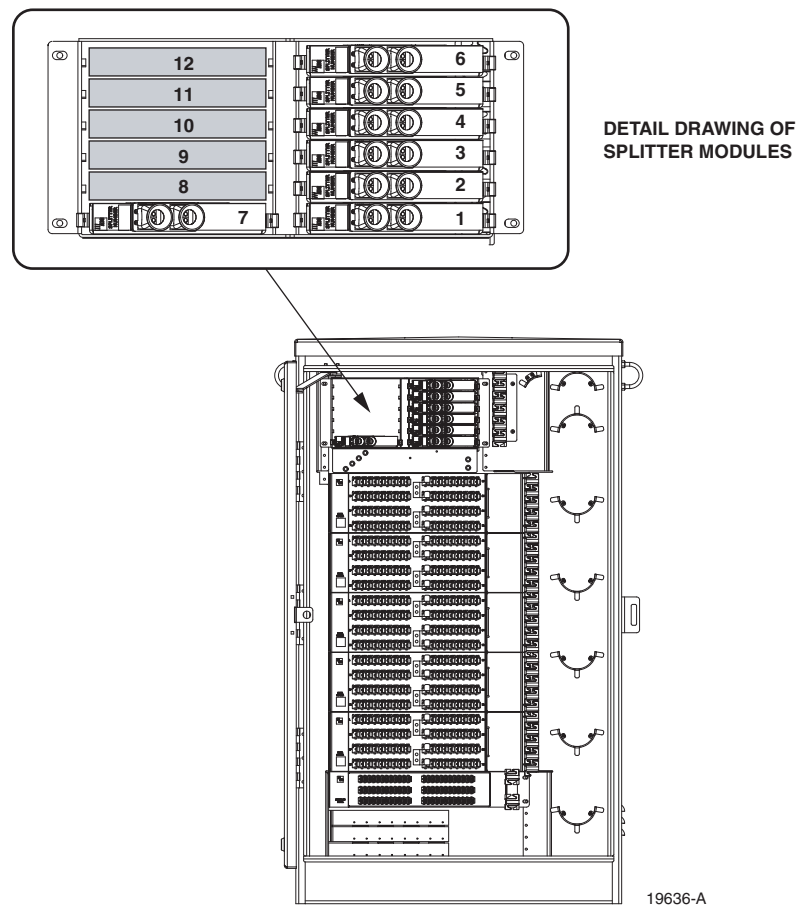
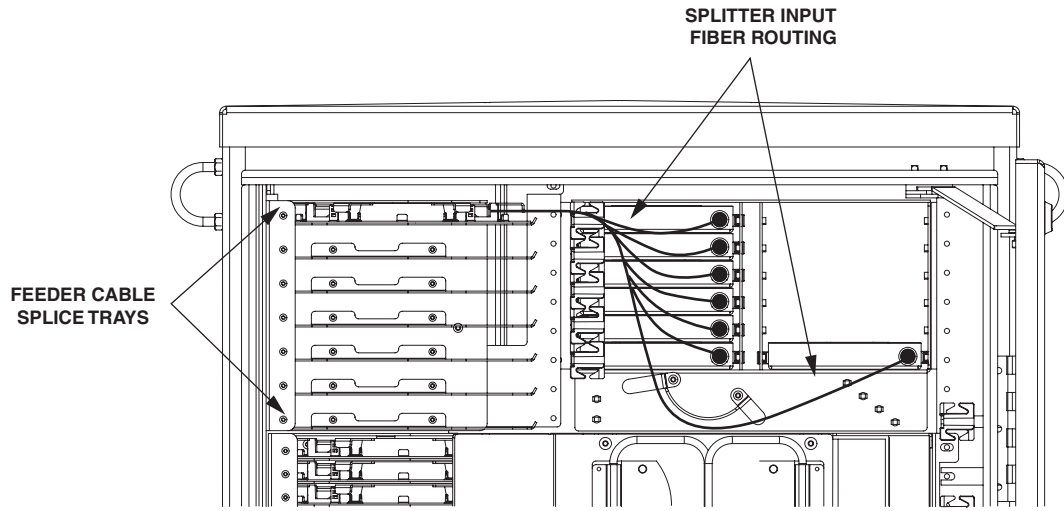

Figure 35. Splitter Module Installation



19637-A

Figure 36. Routing Splitter Input Fibers

4. Remove the splice tray and then coil up the splitter input fiber around the outside edge of the tray for temporary storage.
5. Refer to [Section 5.4](#) for the feeder cable and splitter input fiber splicing procedures.

11 ROUTING AND CONNECTING THE SPLITTER OUTPUT FIBERS

The splitter modules are mounted at the top of the ACE-142S/142V cabinet. When a splitter module is installed, the output fibers are routed to the storage panel located at the bottom of the cabinet. The output fibers are temporarily “parked” in the storage panel until they are needed to provide service. Service to a subscriber is enabled by removing an unused output fiber from the storage panel and routing it to the appropriate connector panel for connection to the subscriber port.

11.1 Storing The Splitter Output Fibers

Use the following procedure to store the splitter output fibers.

1. Following installation of a splitter, route each splitter output fiber over the top spool on the right side of the cabinet as shown in [Figure 37](#).
2. Locate an unused storage port on the storage panel.
3. Hold the output fiber connector near the storage port adapter.
4. Use the slack storage spools on the right side of the cabinet to store any excess fiber slack.
5. Insert the output fiber connector into the storage panel port adapter.

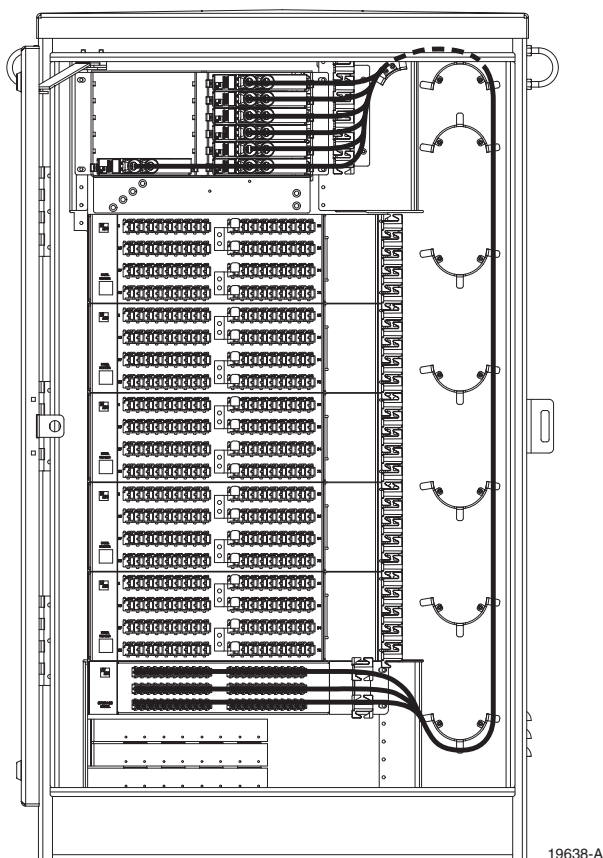

Figure 37. Routing To Storage Panel

11.2 Enabling Service To a Subscriber

Use the following procedure to enable service to a subscriber:

1. Check the designation labels on the cabinet door to determine the connector panel and port number that corresponds to the address of the subscriber.
2. Locate the subscriber port on the specified connector panel and remove both the adapter dust cap and the connector ferrule dust cap.
3. Select and remove an unused splitter output fiber from the storage panel and carefully work it free of any other fibers.
4. Remove the ferrule dust cap from the connector and then clean the connector as specified in the Optical Fiber Systems Cleaning and Mating Instructions (ADCP-90-159)
5. Hold the output fiber connector near the subscriber port.
6. Use the slack storage spools on the right side of the cabinet to store any excess fiber slack as shown in [Figure 38](#).
7. Insert the output fiber connector into the connector panel port adapter.

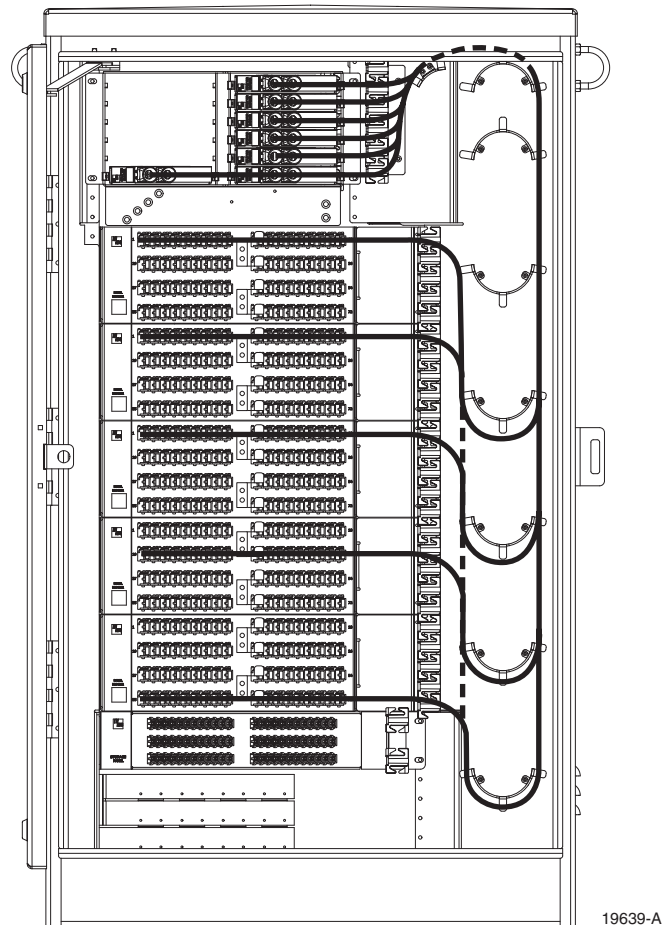

Figure 38. Routing To Connector Panels

12 MAINTENANCE AND REPAIR PROCEDURES

The ACE-142S/142V cabinet requires no regular maintenance to insure continuous and satisfactory operation. Maintenance is limited to repairing or replacing any cabinet components that may be damaged or broken in the course of normal operation. The following sections provide procedures for repairing or replacing common cabinet components.

12.1 Painting

Brush-in-cap type bottles of paint are available (see [Table 2](#)) for touching-up nicks and scratches in the factory coat of paint. Lightly sand the area to be painted and then clean it thoroughly to remove any dirt, dust, or foreign matter. Shake the paint bottle until thoroughly mixed and then apply a light coat of paint to the damaged area using the small brush attached to the cap. Wait until the paint is dry and then apply a second coat if necessary. When finished painting, replace the paint bottle cap and tighten securely.

12.2 Adapter Replacement

Replacement adapters are available for the connector panels. Use the following procedure to remove and replace a damaged adapter:

1. Disconnect the splitter connector from the front side of the adapter as shown in [Figure 39](#).

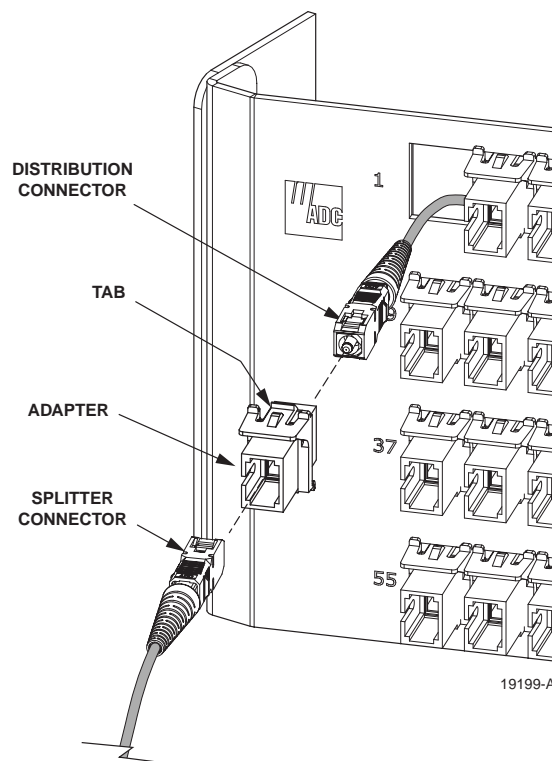

Figure 39. Adapter Removal and Replacement

2. Push down on the small tab at the top of the adapter and at the same time pull outward on the adapter until it is released from the panel.
3. Pull the adapter away from the panel until about 6 inches of fiber are exposed.
4. Disconnect the distribution connector from the rear side of the adapter.
5. Discard the damaged adapter.
6. Clean the distribution fiber connector as specified in Optical Fiber Systems Cleaning and Mating Instructions (ADCP-90-159).
7. Orient the replacement adapter as shown in [Figure 39](#) and then mate the distribution connector with the rear side of the adapter (see ADCP-90-159).
8. Re-install the replacement adapter in the connector panel. Make sure the small tab on the adapter is facing up and that the fiber feeds smoothly back into the connector panel.
9. Clean the splitter connector and mate it with the front side of the replacement adapter (see ADCP-90-159).

12.3 Connector Replacement

Damaged fiber optic connectors may be replaced using a field-installable connector replacement kit. Follow the procedures provided with the kit when replacing a damaged connector. Damaged distribution fiber connectors may be accessed using the procedure in [Section 12.2](#). Clean all optical connectors as specified in Optical Fiber Systems Cleaning and Mating Instructions (ADCP-90-159).

13 CUSTOMER INFORMATION AND ASSISTANCE

PHONE:

EUROPE

Sales Administration: +32-2-712-65 00
 Technical Assistance: +32-2-712-65 42

EUROPEAN TOLL FREE NUMBERS

Germany: 0180 2232923
 UK: 0800 960236
 Spain: 900 983291
 France: 0800 914032
 Italy: 0800 782374

U.S.A. OR CANADA

Sales: 1-800-366-3891 Extension 73000
 Technical Assistance: 1-800-366-3891
 └ Connectivity Extension 73475
 └ Wireless Extension 73476

ASIA/PACIFIC

Sales Administration: +65-6294-9948
 Technical Assistance: +65-6393-0739

ELSEWHERE

Sales Administration: +1-952-938-8080
 Technical Assistance: +1-952-917-3475

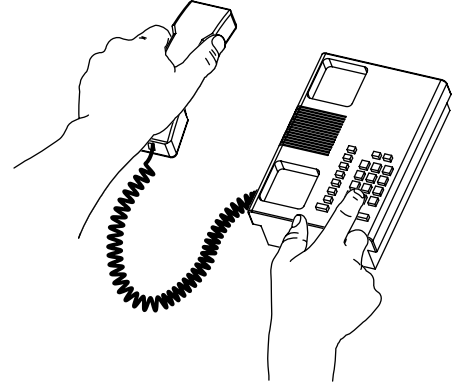

WRITE:

ADC TELECOMMUNICATIONS, INC
 PO BOX 1101,
 MINNEAPOLIS, MN 55440-1101, USA

ADC TELECOMMUNICATIONS (S'PORE) PTE. LTD.
 100 BEACH ROAD, #18-01, SHAW TOWERS.
 SINGAPORE 189702.

ADC EUROPEAN CUSTOMER SERVICE, INC
 BELGICASTRAAT 2,
 1930 ZAVENTEM, BELGIUM

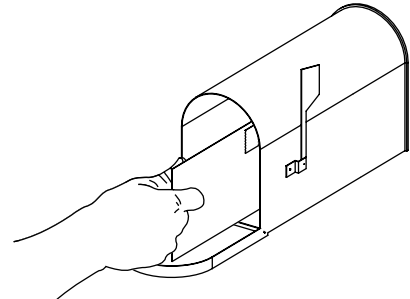

PRODUCT INFORMATION AND TECHNICAL ASSISTANCE:

connectivity_tac@adc.com

wireless_tac@adc.com

euro_tac@adc.com

asiapacific_tac@adc.com

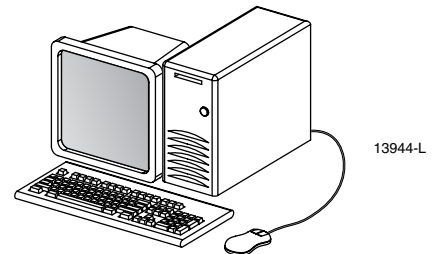

13944-L

Contents herein are current as of the date of publication. ADC reserves the right to change the contents without prior notice. In no event shall ADC be liable for any damages resulting from loss of data, loss of use, or loss of profits and ADC further disclaims any and all liability for indirect, incidental, special, consequential or other similar damages. This disclaimer of liability applies to all products, publications and services during and after the warranty period. This publication may be verified at any time by contacting ADC's Technical Assistance Center.



© 2004, ADC Telecommunications, Inc.
 All Rights Reserved
 Printed in U.S.A.

Free Manuals Download Website

<http://myh66.com>

<http://usermanuals.us>

<http://www.somanuals.com>

<http://www.4manuals.cc>

<http://www.manual-lib.com>

<http://www.404manual.com>

<http://www.luxmanual.com>

<http://aubethermostatmanual.com>

Golf course search by state

<http://golfingnear.com>

Email search by domain

<http://emailbydomain.com>

Auto manuals search

<http://auto.somanuals.com>

TV manuals search

<http://tv.somanuals.com>