

HDSL4

USER MANUAL

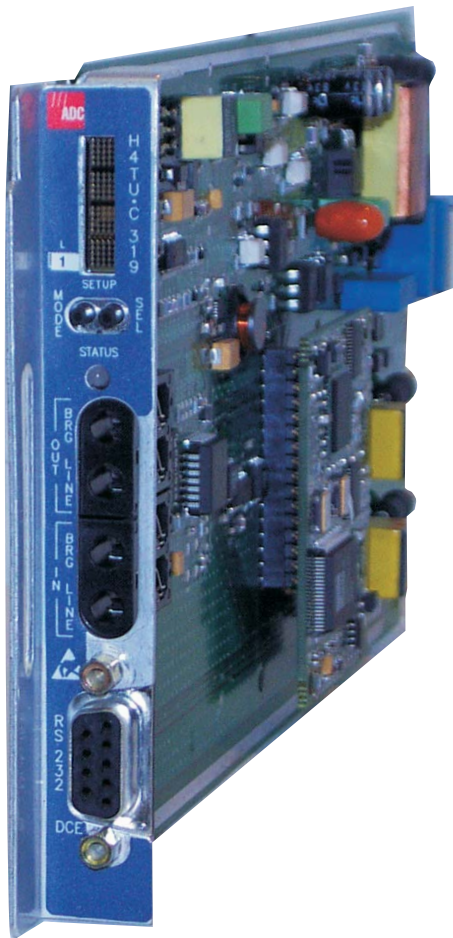

H4TU-C-319 List 1 Line Unit
Product Catalog: H4TU-C-319-L1
CLEI: VACJNUNE



Revision History of This Manual

To order copies of this document, use document number LTPH-UM-1031-03.

Issue	Release Date	Revisions Made
1	April 30, 2001	Initial release.
2	March 15, 2002	Include BERT and doublers. Updated pulse attenuation section.
3	September 12, 2003	Added "Maximum Loop Attenuation" to Appendix A - Specifications.

Copyright

September 12, 2003

© 2003 ADC DSL Systems, Inc. All rights reserved.

Trademark Information

ADC is a registered trademark of ADC Telecommunications, Inc.

HiGain is a registered trademark of ADC DSL Systems, Inc. No right, license, or interest to such trademarks is granted hereunder, and you agree that no such right, license, or interest shall be asserted by you with respect to such trademark. Other product names mentioned in this practice are used for identification purposes only and may be trademarks or registered trademarks of their respective companies.

Disclaimer of Liability

Information contained in this document is company private to ADC DSL Systems, Inc., and shall not be modified, used, copied, reproduced or disclosed in whole or in part without the written consent of ADC.

Contents herein are current as of the date of publication. ADC reserves the right to change the contents without prior notice. In no event shall ADC be liable for any damages resulting from loss of data, loss of use, or loss of profits, and ADC further disclaims any and all liability for indirect, incidental, special, consequential or other similar damages. This disclaimer of liability applies to all products, publications and services during and after the warranty period.

USING THIS MANUAL

The following conventions are used in this manual:

- Monospace type indicates screen text.
- Keys you press are indicated by small icons such as **Y** or **ENTER**. Key combinations to be pressed simultaneously are indicated with a plus sign as follows: **CTRL** + **ESC**.
- Items you select are in **bold**.
- Three types of messages, identified by icons, appear in text.



Notes contain information about special circumstances.



Cautions indicate the possibility of personal injury or equipment damage.



The Electrostatic Discharge (ESD) symbol indicates that a device or assembly is susceptible to damage from electrostatic discharge.

For a list of abbreviations used in this document, refer to [“Appendix E - Abbreviations”](#) on page 67.

INSPECTING SHIPMENT

Upon receipt of the equipment:

- Unpack each container and inspect the contents for signs of damage. If the equipment has been damaged in transit, immediately report the extent of damage to the transportation company and to ADC DSL Systems, Inc. Order replacement equipment, if necessary.
- Check the packing list to ensure complete and accurate shipment of each listed item. If the shipment is short or irregular, contact ADC DSL Systems, Inc. as described in [“Appendix D - Product Support”](#) on page 66. If you must store the equipment for a prolonged period, store the equipment in its original container.

TABLE OF CONTENTS

Overview	1
Features	1
Applications	2
Front Panel	3
Installation	8
Verification	9
Verification without a Downstream Device	9
Verification with a Downstream Device	9
Provisioning	10
Using the MODE and SEL Pushbuttons	10
Setting Options through MODE and SEL	10
Resetting to Factory Default.....	11
Displaying System Parameter Settings.....	11
Disabling an Alarm.....	11
Loopback Modes	11
Using a Maintenance Terminal	12
Connecting to a Maintenance Terminal.....	12
Logon Screen	12
Provisioning Tasks.....	15
Setting Date and Time	15
Setting Circuit ID Numbers.....	16
Configuring the System	17
Clearing the History, Alarm, and Event Log Screens	24
Monitoring System Activity and Performance	25
System Overview	25
Using the Monitor Screen to View System Activity.....	25
Using the Performance Screens to View Performance Data.....	28
Performance History at the DS1 Interface.....	28
Performance History at the HDSL4 Interface	32
Using the Performance Screens to View Alarm Data.....	35
Alarm History at the DS1 Interface	35
Alarm History at the HDSL4 Interface.....	37
Using the Event Log to Track System Events	38
Using the Report Menu	40
Testing	42

System Alarms.....	42
Alarm Option for DLC Feed.....	44
Retiring System Alarms	44
Remote LOS and AIS Response	45
OCT55 Test Pattern with AMI Line Code	45
Loopback Operation	46
Generic Loopback Commands.....	47
Special Loopback Commands.....	47
Manual Loopback Session	48
Loopback Test Procedures	49
General Troubleshooting Tips	49
GNLB Test Procedures	51
A3LB Test Procedure.....	52
A5LB Test Procedure.....	53
Testing with H4TU-C BERT Generator.....	56
Testing with H4TU-R BERT Generator.....	57
Appendix A - Specifications	58
Power Consumption	60
Maximum Power Dissipation	60
Maximum Current Drain	61
Loop Attenuation, Insertion Loss, and Reach	61
H4TU-C-319 Card-Edge Connector.....	62
Network Management Control Bus	62
Fuse Alarm.....	62
System Alarm Output Pin	63
Craft Port	63
Appendix B - Functional Operation	64
Timing	64
Ground Fault Detection	64
Spectrum Issues.....	64
Appendix C - Compatibility	65
Appendix D - Product Support	66
Appendix E - Abbreviations	67
Certification and Warranty	70

LIST OF FIGURES

1. H4TU-C-319 List 1 Front Panel.....	3
2. Installing the H4TU-C-319 List 1 into a Shelf.....	8
3. Logon Screen.....	13
4. Config Menu - Date and Time.....	15
5. Inventory Screen.....	16
6. Config Menu.....	17
7. Config Menu - Standard Options (defaults shown).....	18
8. Config Menu - ADC Options (defaults shown)	18
9. Config Menu - Set Factory Defaults	23
10. Config Menu - Master Clear.....	24
11. System Spans.....	25
12. Monitor Screen - Active Loopback with Alarms	26
13. H4TU-R DS1 31-Day Performance History	28
14. H4TU-C DS1 25-Hour Performance History.....	29
15. H4TU-C DS1 48-Hour Performance History.....	29
16. H4TU-R DS1 Current Statistics	30
17. H4TU-C DS1 Current Statistics	30
18. H4TU-C HDSL (Loop 1/Loop 2) 31-Day Performance History	32
19. H4TU-C HDSL (Loop 1/Loop 2) 48-Hour Performance History.....	32
20. H4TU-C HDSL (Loop 1/Loop 2) 25-Hour Performance History.....	33
21. H4TU-C HDSL (Loop 1/Loop 2) Current Statistics	33
22. H4TU-C DS1 Alarm History Screen.....	35
23. H4TU-R DS1 Alarm History Screen.....	36
24. H4TU-C HDSL Alarm History Screen	37
25. System Event Log.....	38
26. Report Menu - Full Report	40
27. H4TU-R LOS and AIS Response Priorities	45
28. Loopback Summary.....	46
29. Loopback Modes	50
30. H4TU-C BERT Generator Screen.....	56
31. H4TU-R BERT Generator Screen.....	57
32. H4TU-C-319 Card-Edge Connector.....	62
33. RS-232 Craft Port Pinouts.....	63
34. H4TU-C-319 List 1 Block Diagram.....	64

LIST OF TABLES

1. Front-Panel Description	4
2. Front-Panel Display Messages.....	5
3. Navigational Keys for the Maintenance Terminal Screens	12
4. Logon Screen Menus	13
5. H4TU-C-319 List 1 Standard Config Menu Options	19
6. H4TU-C-319 List 1 ADC Config Menu Options	20
7. DS1/DSX-1 24-Hour PM Threshold	22
8. Monitor Screen Descriptions	26
9. Acronyms Used on the DS1 Performance History Screens.....	31
10. Acronyms Used on the HDSL4 Performance History Screens	34
11. DS1 Alarm Descriptions.....	36
12. HDSL4 Alarm Descriptions.....	37
13. Event Log Entry Messages List	39
14. Report Types.....	41
15. Front-Panel System Alarms	42
16. Summary of HDSL4 Loopback and Activation Codes	51
17. A3LB Addressable Repeater Loopback Commands	52
18. A5LB Addressable Repeater Loopback Commands	53
19. BERT Signal Generator Option Settings	56
20. H4TU-C Power Parameters	60
21. HDSL4 Reach Chart	61

OVERVIEW

The H4TU-C-319 List 1 is the Central Office (CO) side of a T1 transmission system. The ADC® four-wire HDSL2 product family (hereafter referred to as “HDSL4”) is based on the HDSL4 standard ANSI T1.418 Issue 2.

The H4TU-C, when used with an H4TU-R remote unit, transmits a 1.544 Mbps payload up to a maximum distance of 12 kft. over two unconditioned copper pairs. Using two doublers (H4Ds), the Carrier Service Area (CSA) reach can be extended to a maximum of 34 kft. The H4TU-C-319 List 1 is designed to mount in 3192 mechanics shelves. For a list of compatible shelves see “Appendix C - Compatibility” on page 65.



The H4TU-C-319 List 1 complies with the protection switching features of the PSC-606 List 1 protection switching card. See the PSC-606 List 1 technical practice, document number LTPH-TP-1006-xx for detailed information.

FEATURES

Standard features include:

- HDSL4 transmission features
 - Lightning and power cross-protection on HDSL4 interfaces
 - Full-duplex HDSL4 transmission on four wire at 1.568 Mbps
 - Ultra-low wander (Stratum 1 compliant)
 - Grounded loop detection on either HDSL4 spans
 - Spectrum compatibility with Asymmetric Digital Subscriber Line (ADSL) services
 - Bit Error Rate Tester (BERT)
 - Three-span range with two doublers (34 kft, 26 AWG)
- Front-panel provisioning features
 - Four-character status display
 - DS1 splitting and bridging access
 - Status Light Emitting Diode (LED)
 - RS-232 craft port for connection to a maintenance terminal
 - MODE and SEL pushbuttons
 - Front-panel dual loopback commands
- Maintenance screens for inventory, provisioning, and troubleshooting
 - DS1 and HDSL4 performance monitoring
 - DS1 and HDSL4 alarm histories
 - Payload (PL) and HDSL Generic (HG) loopback source identification
 - Margin Alarm (MAL) threshold
 - Report menu option for downloading status and performance monitoring data to a file
 - Sources sealing current when connected to any locally powered H4TU-R-402
 - Remote access and control of H4TU-R test signal generator

- Both doubler and non-doubler applications are compatible with ADSL services in same binder group
- Configuration options
 - Selectable DSX-1 pre-equalizer
 - Bipolar Violation Transparency (BPVT)
 - Bit Error Rate (BER) alarm
 - Power Back Off Network (PBON) and Power Back Off Customer (PBOC) options for configuring HDSL4 transmit power levels
 - Loss of Signal/Alarm Indication Signal (LOS/AIS) payload alarm
 - Remote provisioning
 - Concurrent detection of all loopback activation codes
- Additional Loopback Timeout (LBTO) settings of 8 hours and 24 hours
- Network Management and Administration (NMA) interface



DS1 is used throughout this document to refer to either the remote unit's DS1 interface or the line unit's DSX-1 interface.

APPLICATIONS

HDSL4 systems provide a cost-effective, easy-to-deploy method for delivering T1 High Capacity Digital Service (HCDS) over two pair of wires. HDSL4 systems support a multitude of network connections.

- The service is deployed over two unconditioned, non-loaded copper pair at 784 kps per loop.
- Conventional, inline DS1 repeaters are no longer required.
- Cable pair conditioning, pair separation, and bridged tap removal are not required.

For Span 1, each loop has no more than 47 dB of insertion loss (INSL) at 196 kHz, with driving and terminating impedances of 135Ω; for Span 2 and Span 3, each loop has no more than 43 dB of insertion loss at 196 kHz. In general, HDSL4 systems:

- Operate effectively in the same cable binder group with other HDSL4 lines, HDSL, T1, ADSL, SDSL, POTS, Digital Data Service (DDS), and other transmission schemes.
- Can be used with customers requiring DS1 service on a temporary or permanent basis.
- Provide a means of quickly deploying service in advance of fiber-optic transmission systems.

FRONT PANEL

Figure 1 shows the H4TU-C-319 List 1 front panel. Table 1 on page 4 describes the front-panel components. For a list of front-panel display messages, refer to Table 2 on page 5. For pinout diagrams of the H4TU-C card-edge connector and craft port, refer to Figure 32 on page 62 and Figure 33 on page 63, respectively.

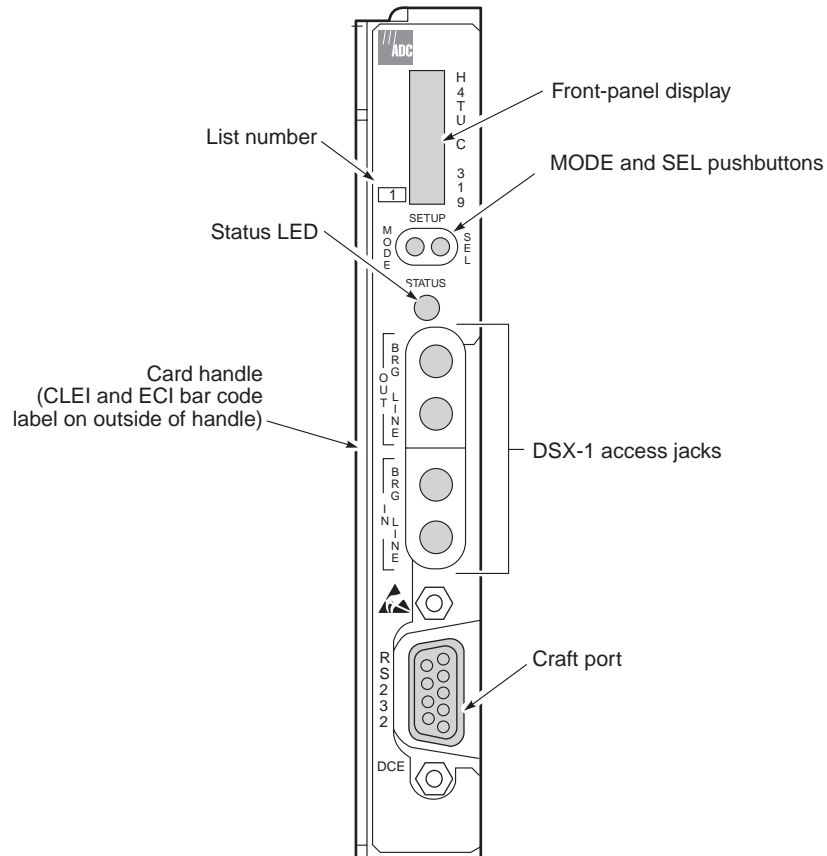

Figure 1. H4TU-C-319 List 1 Front Panel

Table 1. Front-Panel Description

Front-Panel Feature	Function
Front-panel display	Displays four-character status, provisioning, and alarm system messages. The front-panel display illuminates when power is initially applied. To conserve power the display only remains on for 5 minutes. Using the MODE or SEL pushbuttons reactivates the display and restarts the 5-minute timer. Refer to Table 2 on page 5 for a listing of the four-character messages.
List number	Identifies the list number of the H4TU-C-319.
MODE and SEL pushbuttons	Permits user options to be monitored and modified without the need of a maintenance terminal. Used to initiate all HDSL4 loopbacks and to display DSX-1 line parameters and line unit identity.
Status LED	The status LED can report the following conditions:
Off	Line power is off.
Green	Normal operation.
Red	Fuse alarm.
Flashing red	HDSL4 acquisition or system alarm.
Yellow	An H4TU-C-319 Customer Remote Loopback (CREM) or a Network Local Loopback (NLOC) is in effect.
Flashing yellow	H4TU-C-319 is in an Armed (ARM) state.
Card handle	Provides the human-readable Common Language Equipment Identifier (CLEI) code number and the Equipment Catalog Item (ECI) bar code number.
DSX-1 access jacks	
BRG	Provides non-intrusive bridging jack access to (IN) and from (OUT) the HDSL4 span at the DSX-1 interface. Allows the two DS1 payloads to be monitored.
LINE	Provides splitting jack access to (IN) and from (OUT) the HDSL4 span at the DSX-1 interface. Breaks the IN and OUT paths to permit test signal insertion and retrieval.
Craft port (RS-232)	Provides bidirectional communication between the unit and an external terminal to allow configuration and performance monitoring through the maintenance terminal screens.

Table 2 lists the front-panel display messages. The four-character display reports the code of an alarm, loopback, or diagnostic message and, in some cases, is followed by a second four-character message that modifies the first message with a value or current configuration setting.

Table 2. *Front-Panel Display Messages*

Message	Full Name	Description
ALARM MESSAGES		
ACO	Alarm Cutoff	A system alarm has occurred, and has been retired to an ACO condition by pressing the SEL pushbutton on the H4TU-C front panel.
ALRM	Alarm Condition Exists	A system alarm condition is in effect.
DBER	DS1 Bit Error Rate	A system DS1 BER alarm is in effect and remains in effect until cleared.
DU1U or DU1D	Doubler 1 Upstream or Downstream Port	Precedes LA, HBR, and MAL and indicates the first H4D doubler HDSL4 upstream or downstream interface.
DU2U or DU2D	Doubler 2 Upstream or Downstream Port	Precedes LA, HBR, and MAL and indicates the second H4D doubler HDSL4 upstream or downstream interface.
HBRx	HDSL4 Block Error Rate Loop 1 or Loop 2	A system HDSL4 Block Error Rate alarm is in effect. (x indicates Loop 1 or Loop 2.)
LAx	Loop Attenuation Loop 1 or Loop 2	The attenuation on the HDSL4 loop has exceeded the maximum threshold value. (x indicates Loop 1 or Loop 2.)
LAIS	Line Alarm Indication Signal	Indicates an AIS (unframed all ones) pattern is being received or transmitted at the H4TU-C DS1 input or output ports.
LLOS	Line (Unit) Loss of Signal	Indicates that no signal is detected at the DSX-1 input to the H4TU-C. Causes a system alarm.
LOF	Loss of Frame	The DS1 input does not contain the ESF or SF frame pattern setting of the FRMG option.
LOSW	Loss of Sync Word	Indicates that one of the HDSL4 loops has lost synchronization.
LRAI	Line RAI	Indicates an RAI alarm (yellow) from the CPE with an error-free signal from the line unit or network. RAI signal is transmitted towards the network.
MALx	Margin Alarm Loop 1 or Loop 2	The margin at Loop 1 or Loop 2 of the HDSL4 interface has dropped below the threshold (0 to 15 dB) set by the operator. (x indicates Loop 1 or Loop 2.)
PWR FEED GND	Power Feed Ground	The HDSL4 loop is grounded.
PWR FEED OPEN	Power Feed Open	Indicates a line power open condition.
PWR FEED SHRT	Power Feed Short	Indicates a short between Loop 1 and Loop 2 of the HDSL4 pair.
PRMF	Performance Report Messaging - Far End	H4TU-R PRM-FE BER threshold has been exceeded at far end.
PRMN	Performance Report Messaging - Near End	H4TU-R PRM-NE BER threshold has been exceeded at near end.
RAIS	Remote Alarm Indication Signal	Indicates an AIS (unframed all ones) pattern is being received or transmitted at the H4TU-R DS1 input or output ports.
RLOS	Remote (Unit) Loss of Signal	Indicates that no signal is detected at the DS1 input to the H4TU-R. Causes a system alarm.
RRAI	Remote RAI—Remote Alarm Indication at the H4TU-R (Net signal has errors.)	Indicates an RAI alarm (yellow) from the CPE with errors from the line unit or network. RAI-CI signal is transmitted towards the network.
SPN <i>n</i>	Span Number	Accompanies the LOSW alarm and identifies the span where the LOSW alarm occurred.
TUC	Transmission Unit Central Office	Precedes DBER, HBR, MAL, LA, and LOF alarms and indicates that the alarm has occurred at the H4TU-C Central Office unit.
TUR	Transmission Unit Remote End	Precedes DBER, HBR, MAL, LA, and LOF alarms and indicates that the alarm has occurred at the H4TU-R remote unit.

Continued

Table 2. Front-Panel Display Messages (Continued)

Message	Full Name	Description
LOOPBACK MESSAGES		
CDU1	Customer Doubler 1 Loopback	DS1 signal from customer is looped back to the customer at H4D1 (111100).
CDU2	Customer Doubler 2 Loopback	DS1 signal from customer is looped back to the customer at H4D2 (111110).
CLOC	Customer Local Loopback	DS1 signal from customer is looped back to the customer at the H4TU-R.
COLB	Central Office Loopback	Dual loopback at the H4TU-C.
CREM	Customer Remote Loopback	DS1 signal from customer is looped back to the customer at the H4TU-C.
NDU1	Network Doubler 1 Loopback	Signal is looped back to the network at H4D1 (110000).
NDU2	Network Doubler 2 Loopback	Signal is looped back to the network at H4D2 (111000).
NLOC	Network Local Loopback	DSX-1 signal is looped back to the network at the H4TU-C.
NREM	Network Remote Loopback	DSX-1 signal is looped back to the network at the H4TU-R.
RULB	Remote Unit Loopback	Dual loopback at the H4TU-R.
SMJK	Remote SmartJack Loopback	DSX-1 signal is looped back to the network at the H4TU-R SmartJack module.
DIAGNOSTIC MESSAGES		
A=xx	Maximum Loop Attenuation	The Attenuation (A) message appears followed by xx, where xx is the highest loop attenuation of all HDSL interfaces.
ACQ1 or ACQ2	Acquisition 1 or Acquisition 2	The multiplexers of the H4TU-C and H4TU-R are trying to establish synchronization over HDSL4 Loop 1 or Loop 2.
ARM	System Armed	Armed to respond to Intelligent Repeater Loop (ILR) codes.
BAD RT?	No Response from H4TU-R	The H4TU-C receives no response from the H4TU-R, and all HDSL4 loop conditions are normal; therefore, the integrity of the H4TU-R or the HDSL4 loops is questionable.
FERR	Framing Bit Error Occurred	Framing bit error occurred at H4TU-C DSX-1 input.
HxES	HDSL4 CRC Error Loop 1 or Loop 2	H4TU-C HDSL4 Loop 1 or Loop 2 Cyclical Redundancy Check (CRC) error. (Loop 1 has display priority over Loop 2.)
LBPV	Local Bipolar Violation	A bipolar violation has been received at the DSX-1 input to the H4TU-C-319.
1=xx or 2=xx	HDSL4 Loop Margin	Indicates the power of the received HDSL4 signal on each loop relative to noise (S/N with respect to 21.5 dB). Any value of 6 dB or greater is adequate for reliable system operation. (xx denotes lowest margin in dB for Loop 1 and Loop 2.)
MNGD	Managed	The H4TU-C-319 is under control of the H4TU-R-319 network management unit. In this state, the front-panel craft port and pushbuttons are disabled.
PWR FEED OFF	Power Feed Off	HDSL4 span power has been turned off by setting the PWRF option to OFF, or HDSL4 span power has been turned off by use of the A5LB Intelligent Office Repeater (IOR) powerdown code.
PWR FEED ON	Power Feed On	Indicates that the HDSL4 loop power is applied and neither pair is grounded.
SIG1 or SIG2	Signaling	The transceivers of the H4TU-C and H4TU-R are trying to establish contact with each other over HDSL4 on Loop 1 or Loop 2.
SYSTEM INFORMATION MESSAGES ^(a)		
VER x.xx	Software Version Number	The software version number of the H4TU-C-319.
LIST xx	List Number	The list number of the H4TU-C-319.

Continued

Table 2. *Front-Panel Display Messages (Continued)*

Message	Full Name	Description
FRM xxxx	Frame: SF, ESF, UNFR	Defines the type of frame pattern being received from the DSX-1: SuperFrame (SF), Extended SuperFrame (ESF), or Unframed (UNFR).
CODE xxxx	Line Code: AMI, B8ZS	The line code that the H4TU-C is receiving at its DSX-1 interface, if the DS1 option is set to AUTO. Otherwise, it mimics either of the other two DS1 line codes: Alternate Mark Inversion (AMI) or Bipolar with 8-Zero Substitution (B8ZS).
LATT xx	Loop Attenuation	The current loop attenuation threshold setting measured in dB.
MARG xx	Margin	The current margin threshold setting measured in dB.

(a) System information messages scroll in the order listed. To scroll through the messages, press the MODE pushbutton for 3 or more seconds. After system information messages scroll, the front panel displays the line card options (see [Table 5 on page 19](#) and [Table 6 on page 20](#)).

INSTALLATION



Upon receipt of the equipment, inspect the contents for signs of damage. If the equipment has been damaged in transit, immediately report the extent of damage to the transportation company and to ADC.

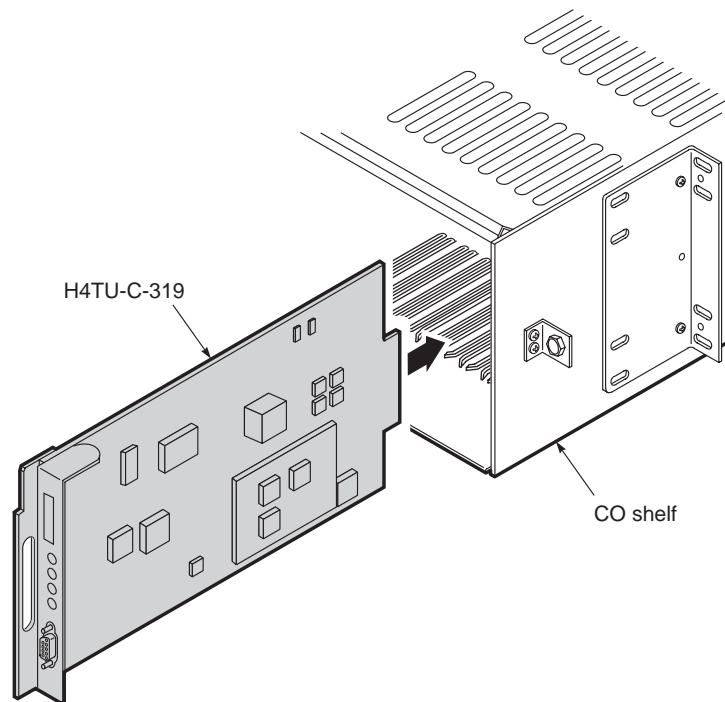

Figure 2. Installing the H4TU-C-319 List 1 into a Shelf



When installing an H4TU-C in a chassis, be sure to wear an antistatic wrist strap. Avoid touching components on the circuit board.



To comply with the intrabuilding wiring requirements of GR-1089 CORE, Section 4.5.9, the shields of the ABAM-type cables that connect the H4TU-C DSX-1 output ports to the cross-connect panel must be grounded at both ends.

- 1 Align the H4TU-C with the enclosure slot guides, then push the unit in until it touches the backplane card-edge connector.
- 2 Place your thumbs on the front panel and push the H4TU-C into the slot guides until properly seated.

VERIFICATION

Once the H4TU-C is installed, verify that it is operating properly. To do this, monitor the following:

- Status LED
- Status messages reported by the front-panel display (see [Table 2 on page 5](#))

Verification without a Downstream Device

If there is no downstream device installed:

- 1 Verify that the H4TU-C powers up. The front-panel display illuminates and reports status messages. (See [Table 2 on page 5](#) for a list of messages.)
- 2 Verify that the H4TU-C attempts to communicate with downstream devices (status LED flashes red). Even if a downstream device is not present, the following events should occur:
 - a The front-panel display reports various four-character status messages.
 - b The H4TU-C again attempts communication until a downstream device is detected.

Verification with a Downstream Device

If a downstream device has been installed:

- 1 Verify that the H4TU-C powers up. (The front-panel display illuminates and reports various status messages.)
- 2 Verify that the H4TU-C attempts to communicate with downstream devices (status LED flashes red). One of the following occurs:
 - If downstream devices are successfully identified and the HDSL4 loop synchronizes, the H4TU-C status LED lights steady green. The H4TU-C reports normal margin and loop attenuation messages on the front-panel display.
 - If downstream devices are not successfully identified, the H4TU-C reports four-character status messages. The H4TU-C attempts communication again and reports four-character status messages. The H4TU-C repeats this cycle until a downstream device is detected.
- 3 If there is more than one span, verify that each subsequent span synchronizes normally by monitoring the front-panel display messages.
- 4 If a remote unit is installed, verify that the last span synchronizes normally. The H4TU-C status LED should light a steady green and the front-panel display should report normal margin messages.
- 5 Verify that a valid DS1 signal has been applied to the H4TU-C and the H4TU-R.
 - If no DS1 signal is being applied to either the H4TU-C or the H4TU-R inputs, then the appropriate DS1 alarms (LLOS or RLOS) display on the front panel and the status LED flashes red.
 - If a valid DS1 signal is being supplied to the H4TU-C and H4TU-R, then DS1 alarm indications should be absent and the status LED should be steady green.

PROVISIONING

There are two methods for provisioning:

- Use the MODE and SEL pushbuttons on the front panel of the H4TU-C to:
 - Set system options
 - Reset the H4TU-C to its factory default settings for system options
 - Display system option settings (scroll mode)
 - Select system loopbacks
- Use a maintenance terminal (ASCII terminal or a PC running terminal emulation software) connected to the H4TU-C craft port (or to an H4MU craft port) to access the maintenance screens (Figure 3 on page 13). This gives you full access to all H4TU-C status, history, inventory, and provisioning screens.



The MNGD message displays if the H4TU-C-319 is under H4MU management. When this occurs, the front-panel pushbuttons and craft port are disabled.



No dip switches or jumpers are required to provision the H4TU-C-319 as it contains a non-volatile RAM (NVRAM) which stores the system option settings. System option settings are retained if shelf power is lost or the H4TU-C-319 is unplugged.

USING THE MODE AND SEL PUSHBUTTONS

Setting Options through MODE and SEL

To provision the H4TU-C-319 through the MODE and SEL pushbuttons on the front panel:

- 1 Press the MODE pushbutton for 1 second and then release it. The front-panel display alternately shows the first system parameter and its current setting.
- 2 Press the SEL pushbutton to step through all possible settings of the selected parameter. (See Table 5 on page 19 and Table 6 on page 20.)
- 3 After the desired setting has been selected, press the MODE pushbutton. This updates the current displayed parameter to the selected setting, then advances to the next configurable parameter. After the last parameter has been selected, a CONF NO message appears on the front-panel display.
- 4 Do one of the following:
 - To cancel the session without saving the requested parameter changes, press the MODE pushbutton or do nothing. (After 30 seconds, the display returns to its normal mode without saving the new changes.)
 - To accept the requested parameter changes, press the SEL pushbutton. (A CONF YES message appears, and the display returns to its normal mode after saving the new changes.)

Resetting to Factory Default

All user options for the H4TU-C-319 List 1 ([Table 5 on page 19](#)) can be set to the factory default values using the MODE and SEL pushbuttons. To set the user options to their default values:

- 1 Press the SEL pushbutton for 6 seconds until the following message appears:

DFLT NO

- 2 Press the SEL pushbutton while the DFLT NO message is displayed.

The message changes to DFLT YES indicating the factory default values are now in effect and the display returns to the normal mode.

To terminate the DFLT mode without setting the factory default values, do one of the following:

- Press the MODE pushbutton to return to the normal display mode.
- Wait 30 seconds for the unit to return to the normal display mode.

Displaying System Parameter Settings

To scroll through the current settings of all system parameters, press the MODE pushbutton for 3 or more seconds. The H4TU-C-319 displays the following parameters:

- Software version number
- List number
- Type of frame pattern received from the DSX-1
- Line code of the signal received from the DSX-1
- All user-configured parameter settings
- Loop attenuation threshold setting
- Margin alarm threshold setting

Disabling an Alarm

System alarms can be disabled by pressing the SEL pushbutton on the H4TU-C-319 front panel for less than 3 seconds. This executes an ACO and returns the H4TU-C-319 to its non-alarm state. For more information about alarms, see [“System Alarms” on page 42](#).

Loopback Modes

See [“Loopback Operation” on page 46](#) for instructions on using the MODE and SEL pushbuttons to activate loopbacks.

USING A MAINTENANCE TERMINAL

Connecting to a Maintenance Terminal

The craft port on the front panel allows you to connect the H4TU-C-319 to a maintenance terminal (ASCII terminal or PC running a terminal emulation program). Once connected to a maintenance terminal, you can access the maintenance, provisioning, and performance screens.

To connect to a maintenance terminal:

- 1 Connect a standard 9-pin terminal cable to the RS-232 craft port (Figure 1 on page 3) on the H4TU-C-319 List 1 front panel.
- 2 Connect the other end of the cable to the serial port on the maintenance terminal.
- 3 Start a terminal emulation program such as Procomm (emulating a VT100 terminal).
- 4 Configure the maintenance terminal to the following communication settings:
 - 9600 baud
 - No parity
 - 8 data bits
 - 1 stop bit
 - Hardware flow control to OFF
- 5 If necessary, press **CTRL** + **R** to refresh the HDSSL4 logon screen.

Logon Screen

The maintenance terminal screens allow you to monitor, provision, and troubleshoot an HDSSL4 system.

To select a menu from the logon screen (Figure 3 on page 13), do one of the following:

- Press the underlined letter of the menu.
- Use the **←** **→** arrow keys to select the menu and press **ENTER**.

Table 3 summarizes the navigational keys. They are also listed in the onscreen Help menu. Table 4 on page 13 describes the Logon screen menus.

Table 3. *Navigational Keys for the Maintenance Terminal Screens*

Key ^(a)	Function
SPACEBAR	Cycle through selections.
ENTER	Activate the current setting or choice, or display a menu.
ESC or F11 (VT100 only)	Return to the parent menu.
↑ or CTRL + E	Select the submenu or item above the current one, or return to the previous menu.
↓ or CTRL + X	Select the submenu or item below the current one.
→ or CTRL + D	Select the menu or item to the right of the current one.
← or CTRL + S	Select the menu or item to the left of the current one, or return to the previous menu.
CTRL + R	Refresh the screen.

(a) Legacy management units require use of control keys instead of arrow keys.



Most VT100 emulation programs support a print screen option. For Windows-based programs, such as Procomm or HyperTerminal, refer to the Help menu for instructions.

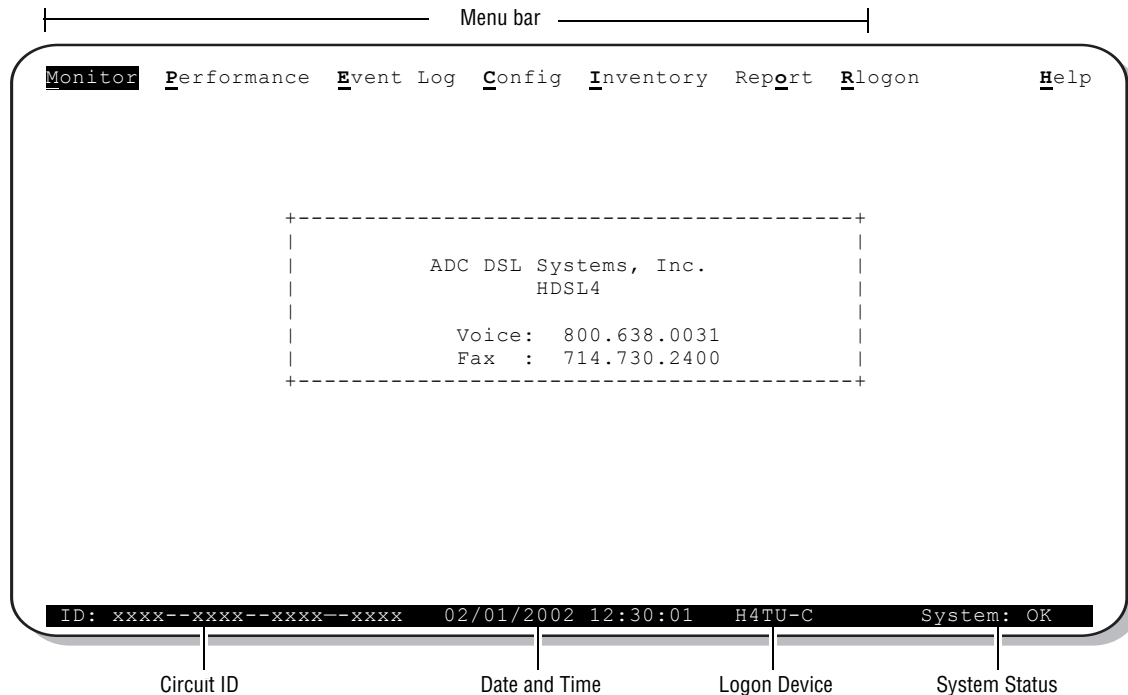

Figure 3. Logon Screen

Table 4. Logon Screen Menus

Press this key:	To access this menu:	Menu Functions
M	Monitor	Monitors loopbacks and alarms, and provides a graphical representation of circuit activity, including ES, UAS, SES, and line code.
P	Performance	Provides performance and alarm histories for current, 25-hour, 48-hour, or 31-day periods for either the DS1 or HDSL4 interface.
E	Event Log	Identifies the 100 most recent system events and reports the date and time of occurrence.
C	Config	Provides standard configuration options, ADC options, BER tester (BERT), date and time setting, and a reset option (factory settings). Also provides a master clear option that clears all performance, alarm, and event log entries. Selecting the Config menu after a remote logon displays the BERT Generator menu, which provides access to the BERT Signal Generator configuration submenu.
I	Inventory	Provides product information about the various devices that are in the system and lists circuit and device identifications.
O	Report	Provides four types of reports: Full Report, Short Report, System Information Report, and Event Report.

Continued

Table 4. Logon Screen Menus (Continued)

Press this key:	To access this menu:	Menu Functions
R	Rlogon / Rlogout	<p>Remote logon can be performed from the H4TU-C or the H4TU-R. The screen displays “Rlogout” when the H4TU-C or H4TU-R is remotely logged on to the other unit at the end of the circuit.</p> <p>Remote logon from the H4TU-C will permit viewing of the H4TU-R BERT Generator configuration submenu.</p> <p>To log off the remote unit, press R. “Rlogout” changes to “Rlogon.” The unit is now locally logged on until R is pressed again to reinitiate a remote logon.</p>
H	Help	<p>Provides a glossary of terms used in the maintenance screens, a list of navigational keys, print guide, and ADC contact information.</p>

PROVISIONING TASKS

After the H4TU-C-319 is successfully installed, perform these basic provisioning tasks:

- 1 Set the date and time (see “Setting Date and Time” on this page).
- 2 Set the circuit ID numbers (see “Setting Circuit ID Numbers” on page 16).
- 3 Make any desired changes to configuration (see “Configuring the System” on page 17).
- 4 Clear history, alarm, and event log screens to remove miscellaneous data during startup (see “Clearing the History, Alarm, and Event Log Screens” on page 24).

Setting Date and Time

```

Monitor  Performance  Event Log  Config  Inventory  Report  Rlogon  Help
+-----+
| Standard Options -> |
| ADC Options      -> |
| BERT Generator   -> |
| Date and Time    -> |
+-----+
| Date (mm/dd/yyyy): 02/01/2002|
| Time (hh:mm[:ss]): 12:30:01  |
+-----+
ID: xxxx--xxxx--xxxx--xxxx  02/01/2002 12:30:01  H4TU-C  System: OK

```

Figure 4. Config Menu - Date and Time

- 1 Press **C** to select the Config menu.
- 2 Use the **↑** and **↓** arrow keys to select **Date and Time**, then press **ENTER**.
- 3 Type the date in the format indicated, then press **ENTER**.
- 4 Type the time in the format indicated (entering seconds is optional), then press **ENTER**.

Setting Circuit ID Numbers

The Inventory screen provides product information on all units in the system and allows setting of the circuit and unit identification numbers.

```

Monitor  Performance  Eevent Log  Config  Inventory  Report  Relogon  Help
-----
                Product Information  -----
Unit      : H4TU-C          H4TU-R          H4DU-1          H4DU-2
Product  : H4TU-C-319     H4TU-R-402     H4D-409         H4D-409
List     : 1                1                1                1
Sw Ver   : 4.00            4.00            4.00            4.00
Build #  : 08              08              08              08
Checksum : 0xA015          0xA015          0x633C          0x633C
H4 Xcvr  : GSPN B165      GSPN B165      GSPN B165      GSPN B165
Serial # : 215689543      215610839      123456789012    123456789012
CLEI    : VACJNUNEAA      VAR1EADAAA      ABCDEFGHIJ      1234567890
Mfg. Date: 9/12/01        7/27/01        11/21/2001     11/20/2001
-----
                Circuit and Unit Identifications  -----
Circuit ID  : xxxx--xxxx--xxxx--xxxx
H4TU-R ID   : yyyy--yyyy--yyyy--yyyy
Circuit Notes:

ID: xxxx--xxxx--xxxx--xxxx  02/01/2002 12:30:01  H4TU-C  System: OK

```

Figure 5. Inventory Screen

- 1 Press **I** to select the Inventory screen.
- 2 Type the Circuit ID number, then press **ENTER**. (The Circuit ID number may consist of up to 24 alphanumeric characters.)
- 3 Type the ID numbers of all other devices listed in the system, pressing **ENTER** after each entry.
- 4 Type any relevant circuit notes, and then press **ENTER**.

Configuring the System

The Config menu (Figure 6) allows you to make the following types of system configuration changes:

- Standard options (Figure 7 on page 18)
- ADC options (Figure 8 on page 18)
- BERT Generator (Figure 30 on page 56)
- Date and time (see “Setting Date and Time” on page 15)
- Master clear (see “Clearing the History, Alarm, and Event Log Screens” on page 24)
- Reset to factory default configuration (Figure 9 on page 23)

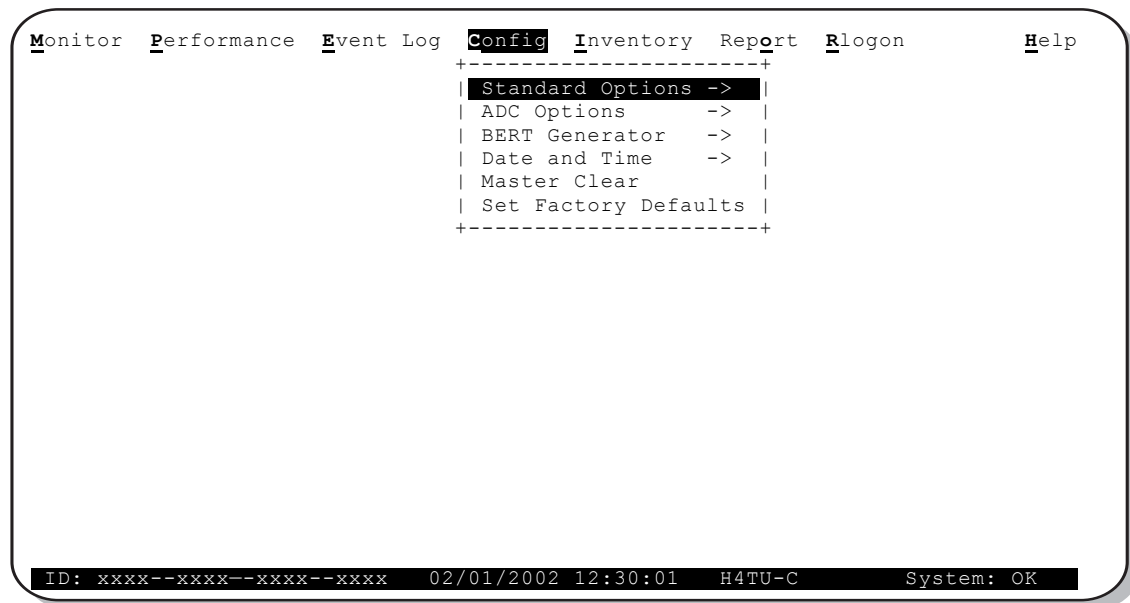

Figure 6. Config Menu

Making Changes to Standard and ADC Options

Figure 7 and Figure 8 on page 18 show the Standard and ADC configuration options. Standard options are supported by HDSL4 units when connected to units from other vendors. ADC options are an extended set of options available only when using ADC units exclusively. For a description of each option and a list of possible option settings, refer to Table 5 on page 19 and Table 6 on page 20. To make changes to these options:

- 1 Press **C** to select the Config menu.
- 2 Use the **↑** and **↓** arrow keys to select **Standard Options** or **ADC Options**, then press **ENTER**.
- 3 Use the arrow keys to select an option.
- 4 Press the **SPACEBAR** to cycle through the available settings for that option.
- 5 Press **ENTER** to activate your choice.



The message May need to change MUX option after changing this option appears when changing the DS1 Line Coding (DS1) or H4TU-C Equalization (EQL) option in the Standard Options configuration screen. (This applies when the H4TU-C is used in a Wideband 3190 which contains a multiplexer.)

```

Monitor Performance Event Log Config Inventory Report Rlogon Help
+-----+
| Standard Options -> |
+-----+
| Loopback Timeout (LBTO) : 60 min |
| Loop Attenuation Threshold (LATT) [0-50]: 38 dB |
| Margin Threshold (MARG) [0-15]: 4 dB |
| DS1 Frame Formatting (FRMG) : AUTO |
| DS1 Line coding (DS1) : AUTO |
| H4TU-C Equalization (EQL) : 0 ft |
| H4TU-R Line Buildout (RLBO) : 0 dB |
| Alarm Pattern (ALMP) : AIS |
| H4TU-R TLOS Loopback (TLOS) : DIS |
| Network Loopback Pattern (NLBP) : AIS |
| Power Back Off Network (PBON) : DEF |
| Power Back Off Customer (PBOC) : DEF |
+-----+

Use <Spacebar> to cycle through option settings and <Enter> to activate
ID: xxxx--xxxx--xxxx--xxxx 02/01/2002 12:30:01 H4TU-C System: OK
    
```

Figure 7. Config Menu - Standard Options (defaults shown)

```

Monitor Performance Event Log Config Inventory Report Rlogon Help
+-----+
| Standard Options -> |
| ADC Options -> |
+-----+
| Line Power Feed (PWRP) : AUTO |
| Remote Provisioning (RTPV) : ENA |
| Bipolar Violation Transparency (BPVT) : DIS |
| DS1 BER (DBER) : DIS |
| HDSL4 BER Threshold (HBER) : NONE |
| SmartJack Loopback (LPBK) : ENA |
| Minor Alarm (ALM) : DIS |
| Remote Disconnect Alarm (RDA) : ENA |
+-----+

Use <Spacebar> to cycle through option settings and <Enter> to activate
ID: xxxx--xxxx--xxxx--xxxx 02/01/2002 12:30:01 H4TU-C System: OK
    
```

Figure 8. Config Menu - ADC Options (defaults shown)

Table 5 describes the Standard Config menu options and lists their menu screen display codes. Table 6 on page 20 describes the ADC Config menu options. Selections in bold type are the factory default settings.

Table 5. H4TU-C-319 List 1 Standard Config Menu Options

Standard Config Menu Options	Screen Display Code	Selection	Description
Loopback Timeout	LBTO	NONE	Disables automatic time-out cancellation of all loopbacks.
		20 min	Sets automatic cancellation of all loopbacks to 20 minutes after initiation.
		60 min	Sets automatic cancellation of all loopbacks to 60 minutes after initiation.
		120 min	Sets automatic cancellation of all loopbacks to 120 minutes after initiation.
		8 hr	Sets automatic cancellation of all loopbacks to 8 hours after initiation.
		24 hr	Sets automatic cancellation of all loopbacks to 24 hours after initiation.
Loop Attenuation Threshold	LATT	0 through 50 dB	Determines the maximum loop attenuation before an alarm is declared. Zero disables the alarm. The loop attenuation threshold cannot be set from the front-panel pushbuttons.
		38 dB	Default value.
Margin Threshold	MARG	0 to 15 dB	Determines the minimum allowable margin below which a system alarm can occur. Zero disables the alarm. The Margin (Alarm) threshold cannot be set from the front-panel pushbuttons.
		4 dB	Default value.
DS1 Frame Formatting	FRMG	AUTO	Configures the HDSL4 system to operate in an auto-framing (AUTO) mode. It detects and locks to both SF or ESF DS1 frame patterns. Line and path performance parameters are maintained and displayed. Unframed payloads cause the ES-P and SES-P counters to increment.
		SF	Configures the HDSL4 system to search for the SF framing pattern at its DS1 input.
		ESF	Configures the HDSL4 system to search for the ESF framing pattern at its DS1 input.
		UNFR	Configures the same as AUTO except unframed payloads do not cause the ES-P and SES-P counters to increment.
DS1 Line Coding See "DS1 Line Coding (DS1) Option" on page 21.	DS1	AUTO	The H4TU-C and H4TU-R monitor the incoming DS1 bit streams for the B8ZS code. If the H4TU-R detects this code, the H4TU-C enters B8ZS output mode. The H4TU-C reverts back to AMI output mode if no B8ZS codes are received at the H4TU-R input for 5 seconds. Similarly, when the H4TU-C detects the B8ZS code, the H4TU-R enters the B8ZS mode and returns to AMI mode if no B8ZS code is received at the H4TU-C input for 5 seconds.
		B8ZS	Places both the H4TU-C and H4TU-R into their B8ZS modes.
		AMI	Places both the H4TU-C and H4TU-R into their AMI modes.
H4TU-C Equalization See "H4TU-C Equalization (EQL) Option." on page 21.	EQL	0 ft	Sets the Equalizer to DSX-1 for 0 to 132 feet.
		133 ft	Sets the Equalizer to DSX-1 for 133 to 265 feet.
		266 ft	Sets the Equalizer to DSX-1 for 266 to 398 feet.
		399 ft	Sets the Equalizer to DSX-1 for 399 to 532 feet.
		533 ft	Sets the Equalizer to DSX-1 for 533 to 655 feet.
H4TU-R Line Buildout	RLBO	0 dB	Sets the DS1 receive level output toward the Customer Interface (CI). Line buildout can only be set through the maintenance screens. Sets the DS1 RLBO level toward the CI to 0 dB.
		-7.5 dB	Sets the DS1 RLBO level toward the CI to -7.5 dB.
		-15 dB	Sets the DS1 RLBO level toward the CI to -15.0 dB.
Alarm Pattern See "Alarm Pattern (ALMP) Option." on page 22.	ALMP	AIS	Enables the HDSL4 system to output an AIS payload at its DS1 ports for LOSW and LOS DS1. For priority resolution, see Figure 27 on page 45.
		LOS	Enables the HDSL4 system to output an LOS condition at its DS1 ports for LOSW and LOS DS1.

Continued

Table 5. H4TU-C-319 List 1 Standard Config Menu Options (Continued)

Standard Config Menu Options	Screen Display Code	Selection	Description
H4TU-R TLOS Loopback	TLOS	ENA	Enables a logic loopback at the H4TU-R when an LOS occurs at its DS1 input. For priority resolution, see Figure 27 on page 45 .
		DIS	Disables TLOS logic loopback.
Network Loopback Pattern	NLBP	AIS	Enables the H4TU-R to transmit AIS towards the CI for any network loopback. For priority resolution, see Figure 27 on page 45 .
		LOS	Enables the H4TU-R to transmit LOS towards the CI for any network loopback.
Power Back Off - Network See “Power Back Off (PBON and PBOC) Options” on page 22.	PBON	DEF	Configures the power output levels of the H4TU-C network unit toward the customer to comply with the Default template as defined in Section 6.1.4.2 of ANSI T1.418.
		ENH	Configures the power output levels of the H4TU-C network unit toward the customer to comply with the Enhanced template as defined in Section 6.1.4.2 of ANSI T1.418.
Power Back Off - Customer See “Power Back Off (PBON and PBOC) Options” on page 22.	PBOC	DEF	Configures the power output levels of the H4TU-R customer unit toward the network to comply with the Default template as defined in Section 6.1.4.2 of ANSI T1.418.
		ENH	Configures the power output levels of the H4TU-R customer unit toward the network to comply with the Enhanced template as defined in Section 6.1.4.2 of ANSI T1.418.

Table 6. H4TU-C-319 List 1 ADC Config Menu Options

ADC Config Menu Options	Screen Display Code	Selection	Description
Line Power Feed	PWRF	OFF	Disables powering to the HDSL4 pair.
		LOW	Keeps the HDSL4 line voltage at nominal -185 Vdc.
		HIGH	Keeps the HDSL4 line voltage at nominal ± 123 Vdc.
		AUTO	Keeps the H4TU-C line voltage at -185 Vdc when line powering up to two devices (one doubler and one remote unit, or two doubler units). When line powering of more than two devices is required, the line unit automatically switches to ± 123 Vdc.
Remote Provisioning	RTPV	ENA	Enables remote provisioning.
		DIS	Disables remote provisioning.
Bipolar Violation Transparency See “Bipolar Violation Transparency (BPVT) Option” on page 22.	BPVT	ENA	Enables BPVs and HDSL4 CRC errors at the DS1 input to be converted into DS1 BPVs at the DS1 output at the distant end. This makes HDSL4 transparent to BPVs.
		DIS	Disables BPV Transparency.
DS1 BER Threshold See “DS1 Bit Error Rate (DBER) Option” on page 22.	DBER	ENA	Enables the fixed 24-hour DS1 BER threshold.
		DIS	Prevents the generation of a system alarm due to DS1 BER.

Continued

Table 6. H4TU-C-319 List 1 ADC Config Menu Options (Continued)

ADC Config Menu Options	Screen Display Code	Selection	Description
HDSL4 BER Threshold	HBER	1E-6	System alarm relay contact closes and the Status LED flashes red when the Block Error Rate (BER) exceeds 10^{-6} . (Block Error Rate is based on the definition of Bit Error Rate.)
		1E-7	System alarm relay contact closes and the Status LED flashes red when BER exceeds 10^{-7} .
		NONE	Prevents generation of a system alarm due to BER.
SmartJack Loopback	LPBK	ENA	Enables the HDSL4 system to recognize all inband SmartJack (SMJK) loopback commands.
		DIS	Configures the HDSL4 system to ignore all inband SmartJack loopback commands.
Minor Alarm	ALM	ENA	Enables the generation of the output alarm on pin H when a system alarm condition occurs.
		DIS	Disables the generation of the output alarm on pin H when a system alarm condition occurs.
Remote Disconnect Alarm	RDA	ENA	Enables a remote DS1 LOS condition at the input to the H4TU-R to generate an LOS alarm. AIS or LOS (depending on ALMP) is sent towards the network.
		DIS	Prevents a remote DS1 LOS condition at the input to the H4TU-R from causing an LOS alarm. The front-panel Status LED still flashes red and the ALRM RLOS message appears, but the alarm relay contacts do not close and LOS is sent towards the network from the H4TU-C instead of AIS.

HDSL4 Block Error Rate Threshold (HBER) Option. The HBER option permits monitoring of loop integrity and reporting of alarms when excessive errors are detected. The performance monitoring (PM) primitive used for this purpose is the CRC checksum performed on the HDSL4 frame for both directions of transmission. It is, therefore, called a block error rate rather than the bit error rate associated with the DS1 interface. The Monitor screen displays the CRC errors and counts for both the H4TU-C and H4TU-R. The HBER option allows an alarm to be generated if the total number of CRCs at either the H4TU-C or H4TU-R exceeds the selected BER threshold during the last 1-minute interval.

- HBER option = 1E-6. Alarm is generated if CRC > 93
- HBER option = 1E-7. Alarm is generated if CRC > 9

Once initiated, the HBER count clears when the CRC count drops below the selected threshold. Selecting NONE inhibits this alarm.

DS1 Line Coding (DS1) Option. The DS1 line code option should always be set to conform to the type of DS1 service (AMI or B8ZS) being provided by the system. The Auto mode, which can adapt to either AMI or B8ZS, should only be used in applications that require it (such as when ADC system acts as a standby circuit to DS1 circuits whose line codes are not known or may be both AMI and B8ZS). This is because the Auto mode induces one BPV in the DS1 bit stream whenever it switches from AMI to B8ZS. The Auto mode allows both the H4TU-C and the H4TU-R to set its DS1 output code to that which is being received at the distant end DS1 input. This forces the input and the output codes in each direction of transmission to be identical.

H4TU-C Equalization (EQL) Option. The equalizer shapes the DS1 output signal of the H4TU-C to conform to a very specific pulse template when it arrives at the DSX-1 cross-connect point. The degree of pulse-shaping required is a function of the distance between the H4TU-C's equipment bay and the DSX-1 panel. Thus, the equalizer has six discrete settings, in increments of 133 feet to cause the maximized separation of 655 feet.

Alarm Pattern (ALMP) Option. To improve HDSL4 compatibility with the switch-to-protect features used in Digital Loop Carrier (DLC) feeder applications, the H4TU-C-319 has an ALMP option that allows you to select either an AIS or LOS DS1 output payload for the following alarms:

- LOSW on any loop
- LOS DS1

Bipolar Violation Transparency (BPVT) Option. The H4TU-C-319 improves compatibility with Digital Loop Carrier (DLC) feeder applications because of its ability to transmit DS1 BPV occurrences between its DS1 interfaces. This feature is required to support protection switching in DLC applications. Each DLC terminal must be able to monitor the integrity of its Receive DS1 payload and then switch to the protect line when the integrity of the path drops below specific user selected limits. An essential requirement of this feature is the need for each DLC terminal to detect BPVs in its DS1 input. Standard HDSL systems correct DS1 BPVs at the input and, therefore, prevent them from being detected by the DLC terminals to which they are connected. The H4TU-C-319 and its associated remote units remove this limitation and become BPV transparent by detecting and counting input BPVs at each end and then by replicating them at the DS1 output port of the distant end.

The BPV count is converted into BPVs at the distant end during the following second at a rate of 1 BPV every 128 DS1 bits up to a maximum of 12000 ($BER=7.7 \times 10^{-3}$). This maximum rate is more than adequate since it exceeds the maximum 10^{-3} BER required by most DLC systems.

DS1 Bit Error Rate (DBER) Option. The DS1 BER alarm occurs when any of the DS1 or DSX-1 performance monitoring parameters listed in [Table 7](#) exceed the counts shown for the 24-hour period between 12:00:00 AM through 11:59:59 PM. These thresholds correspond to a 10^{-6} BER. All PM counters clear to zero at 12:00:00 AM or when Master Clear is selected.

Table 7. DS1/DSX-1 24-Hour PM Threshold

Parameter	Threshold Count
CV-L (BPV)	133,400
CV-P (CRC)	132,960
CV-P (FE in SF)	691
ES-L, ES-P, PRM-NE, PRM-FE	648
SES-L, SES-P	100
UAS-P, UAS-L	10

Power Back Off (PBON and PBOC) Options. Power Back Off Network (PBON) and Power Back Off Customer (PBOC) allow the HDSL4 circuit to support two transmit power templates: default (DEF), higher level, and enhanced (ENH), lower level. These are defined in the four-wire section of the ANSI T1.418 Issue 2 HDSL2 standard. Each HDSL4 receiver detects the level it is receiving during the start-up, pre-activation sequence. It then compares this level to the level it should be receiving according to the PBON and PBOC option settings (DEF or ENH). If the received level is outside the template limits, the receiver sends a message to the upstream HDSL4 transmitter requesting the proper level. These levels are adjusted only during the start-up routine or if the PBON or PBOC option settings are changed during normal operation. Since the ENH template levels are up to 15 dBm below those of the DEF template, the ENH setting can be used to reduce crosstalk levels into adjacent circuits. (For example, if crosstalk noise is being induced by the H4TU-R, set the PBOC option to its lower (ENH) level setting. Conversely, if the HDSL4 signal at the H4TU-R is being affected by crosstalk noise induced from adjacent pairs, set the PBOC option to its higher (DEF) level setting.



Changing these Power Back Off option settings on a live circuit causes the HDSL4 loop to momentarily drop and then reacquire synchronization. This setting can also affect the operating margins.

Resetting to Factory Defaults



Resetting the H4TU-C to its original factory settings may cause interruption of service.

To reset the H4TU-C-319 to its original factory defaults:

- 1 Press **C** to select the Config menu.
- 2 Use the **↑** and **↓** arrow keys to select **Set Factory Defaults**, then press **ENTER**.
- 3 Press **Y** if you are certain you want to reset the H4TU-C, or press **N** to cancel this action.

```

Monitor  Performance  Event Log  Config  Inventory  Report  Rlogon  Help
+-----+
| Standard Options -> |
| ADC Options      -> |
| BERT Generator   -> |
| Date and Time    -> |
| Master Clear     |
| Set Factory Defaults |
+-----+

SETTING FACTORY DEFAULTS...SERVICE MAY BE INTERRUPTED! ARE YOU SURE (Y/N)?
ID: xxxx-xxxx-xxxx-xxxx 02/01/2002 12:30:01 H4TU-C System: OK

```

Figure 9. Config Menu - Set Factory Defaults

Clearing the History, Alarm, and Event Log Screens

Select Master Clear to clear the History, Alarm, and Event Log screens after the system has been installed and is functioning properly. This removes miscellaneous data acquired during the startup session and ensures collection of accurate and meaningful data thereafter.

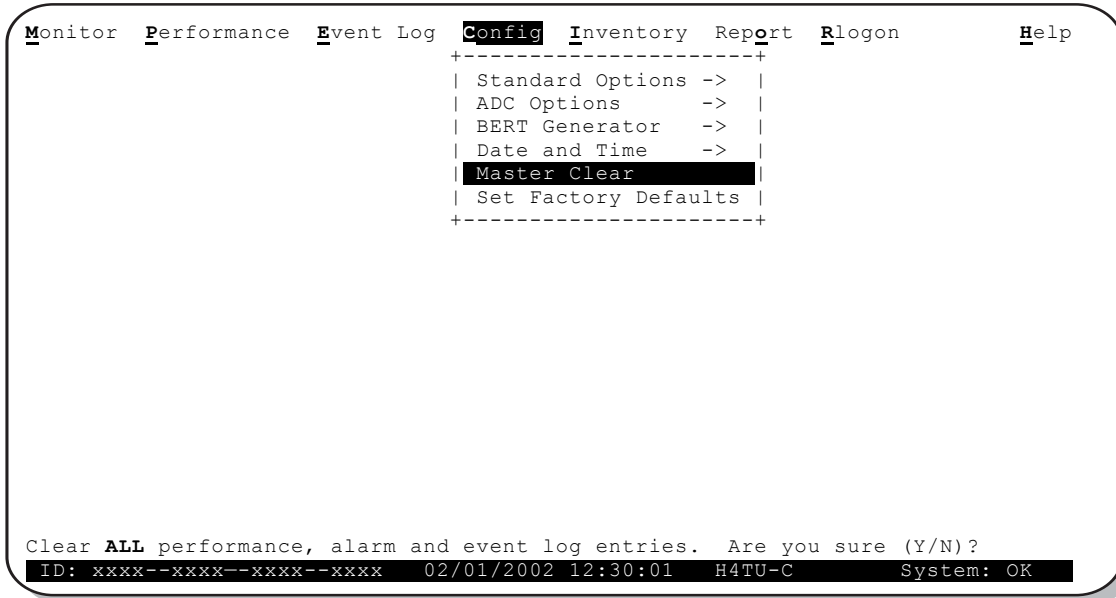

Figure 10. Config Menu - Master Clear

To clear the Event Log, press **E** to select the Event Log screen, then press **L** to clear the screen.

To clear an individual history or alarm screen, do the following:

- 1 Press **P** to select the Performance screen.
- 2 Press the **SPACEBAR** to select either interface (**H4TU-C DS1**, **H4TU-R DS1**, **H4TU-C HDSL**, **H4DU-1 NET HDSL**, **H4DU-1 CPE HDSL**, **H4DU-2 NET HDSL**, **H4DU-2 CPE HDSL**, or **H4TU-R HDSL**), then press **ENTER**.
- 3 Press **↓** to select statistics.
- 4 Press the **SPACEBAR** to select the type of statistics (**Current**, **Alarm History**, **25-Hour History**, **48-Hour History**, or **31-Day History**), and press **ENTER** after your selection.
 - Selecting **31-Day History** allows you to clear the current, 25-hour, 48-hour, and 31-day performance history screens for the selected interface.
 - Selecting **Alarm History** allows you to clear the alarm history screen for the selected interface. For information about the DS1 and HDSL4 Alarm screens, see [Table 11 on page 36](#).
- 5 Press **L** to clear the screen.
- 6 Press **Y** to confirm.

To clear ALL history, alarm, and event log screens by this method:

- 1 Press **C** to select the Config screen.
- 2 Use the **↑** and **↓** arrow keys to select **Master Clear**.
- 3 Press **ENTER** to activate.
- 4 Press **Y** to confirm (clear all screens).

MONITORING SYSTEM ACTIVITY AND PERFORMANCE

The HDSL4 system provides the following maintenance screens for monitoring system activity and assessing performance.

- The Monitor screens provide a graphical representation of circuit activity and allow initiation of loopbacks.
- The Performance screens provide current, 25-hour, 48-hour, and 31-day performance histories and a continuous alarm history.
- The Event Log provides a description of the 100 most recent events which include their origin, time and date of occurrence, and message.

SYSTEM OVERVIEW

The H4TU-C-319 List 1 supports up to two doublers with three HDSL4 spans as shown in [Figure 11](#).

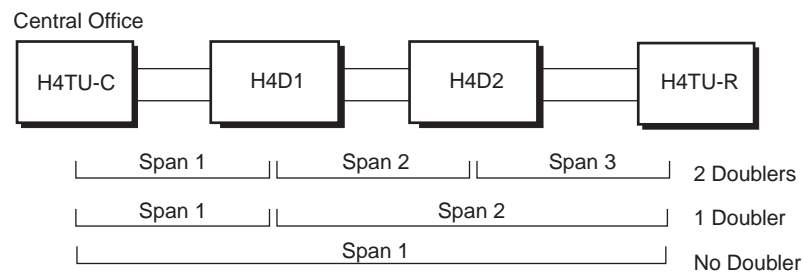

Figure 11. System Spans

The Monitor and Performance screens provide important activity and performance information about the HDSL4 spans and span devices.

USING THE MONITOR SCREEN TO VIEW SYSTEM ACTIVITY

- 1 Press **M** to view the system diagram.

[Figure 12 on page 26](#) shows an armed circuit with an active loopback and alarms. Terms used on the system diagram are defined in the onscreen Help menu glossary. Abnormal situations are highlighted on the diagram. See [Table 8 on page 26](#) for screen field descriptions.

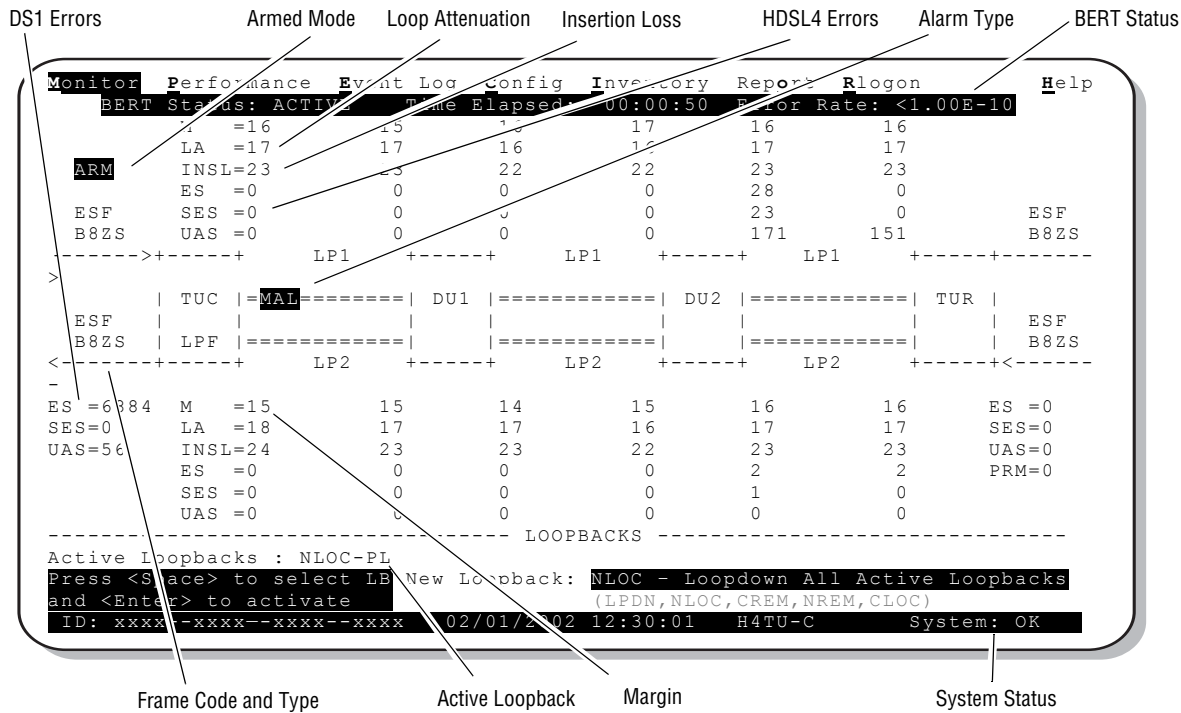

Figure 12. Monitor Screen - Active Loopback with Alarms

- To initiate a loopback, press the **SPACEBAR** to cycle through the loopback choices. Press **ENTER** to make your choice.

When prompted with the message: Are you sure (Y/N)?, press **Y** to initiate the loopback or **N** to cancel. For more information about loopbacks and troubleshooting, see “Testing” on page 42.

- To initiate a loopdown of all active loopbacks, press the **SPACEBAR** to select **LPDN**, then press **ENTER**. When prompted with the message: Are you sure (Y/N)?, press **Y** to initiate the loopdown or **N** to cancel.

Table 8. Monitor Screen Descriptions

Field	Description
Active Loopback	An active loopback is indicated on the lower third of the Monitor screen. Available loopbacks are indicated by gray text. See Table 16 on page 51 for a summary of the HDSL4 generic loopback codes and activation methods.
Alarm Type	Indicates type of alarm.
MAL	Margin Alarm—Indicates the margin on HDSL4 loop has dropped below the threshold (0 to 15 dB) set by the operator.
Armed Mode	Indicates system is in an armed state for an intelligent repeater loopback command.
BERT Status	Provides BERT Generator status, elapsed time, and BERT results.
DS1 Errors	
ES Count	Errored Seconds—The sum of the Errored Seconds-Line (ES-L) and Errored Seconds-Path (ES-P) counts detected on the DS1 input over a 24-hour period. Errors included are: DS1 frame errors, BPV, and ESF CRC errors.
SES Count	Severely Errored Seconds—The sum of the DS1 Severely Errored Seconds-Line (SES-L) and Severely Errored Seconds-Path (SES-P) counts over the last 24 hours.

Continued

Table 8. Monitor Screen Descriptions (Continued)

Field	Description
UAS Count	Unavailable Seconds—The number of seconds during which the DS1 input signal was absent over a 24-hour period.
Frame and Code Type	
ESF	Type of DS1 framing used on the input stream (SF, ESF, or UNFR).
B8ZS	Type of DS1 line coding used (B8ZS or AMI).
HDSL4 Errors	
ES Count	Errored Seconds—The number of 1-second intervals that contained at least one CRC or LOSW error. This value is a running total of the last 24 Hours.
SES Count	Severely Errored Seconds—The number of 1-second intervals that contain at least 50 CRC errors or one or more LOSW defects. (An LOSW defect occurs when at least three consecutive HDSL frames contain one or more frame bit errors.) This value is a running total of the last 24 hours.
UAS Count	Unavailable Seconds—The number of seconds the HDSL4 loop is unavailable. This occurs after 10 contiguous HDSL SES and is retired after 10 contiguous non-SES seconds. This value is a running total of the last 24 hours.
ID	Circuit identification number.
INSL	Insertion Loss—The signal loss value for a 196 kHz signal over the cable pair.
LA	Loop Attenuation—Indicates the attenuation of the Overlapped Pulse Amplitude Modulation (OPAM) transmission pulse from the distant end. Proper HDSL4 loop operation requires that this value be less than 34 dB. This value differs from the insertion loss value of a conventional 196 kHz signal.
LPF	Line Power Feed—Indicates the HDSL4 line power is on.
M	Margin—The signal-to-noise ratio at all HDSL4 ports, relative to a 10^{-7} Bit Error Rate.
PL (or HG)	PL displays when the loopback was initiated by a command embedded in the DS1 data path payload (PL). HG displays when the loopback was initiated from a HDSL Generic (HG) front panel or by a maintenance terminal loopback command.
PRM	The sum of the Performance Report Messaging-Near End (PRM-NE) and Performance Report Messaging-Far End (PRM-FE) counts.
System Status	The presence or absence of an alarm condition is indicated on the lower right corner of all screens. System: OK indicates that there are no alarms present; System: Alarm indicates the presence of an alarm. Refer to “Using the Performance Screens to View Alarm Data” on page 35.

USING THE PERFORMANCE SCREENS TO VIEW PERFORMANCE DATA

The Performance screens display:

- DS1 and HDSL4 statistics in 31-day, 48-hour, 25-hour, and current history reports.
- Alarm statistics for the HDSL4 (Figure 22 on page 35) or DS1 interfaces (Figure 23 on page 36) on a continuous basis.

To access the Performance history screens:

- 1 Press **P** to select the Performance screen.
- 2 Press the **SPACEBAR** to select either interface (**H4TU-C DS1**, **H4TU-R DS1**, **H4TU-C HDSL**, **H4DU-1 NET HDSL**, **H4DU-1 CPE HDSL**, **H4DU-2 NET HDSL**, **H4DU-2 CPE HDSL**, or **H4TU-R HDSL**), then press **ENTER**.
- 3 Press the **SPACEBAR** to select the type of statistics (**Current**, **Alarm History**, **25-Hour History**, **48-Hour History**, or **31-Day History**), then press **ENTER**.

Performance History at the DS1 Interface

The performance history for the DS1 interface provides 31-day, 48-hour, 25-hour, and current statistics screens for the H4TU-C and the H4TU-R (as viewed from the H4TU-C).

Figure 13 is an example of an a DS1 performance history screen at the remote unit. Figure 14 and Figure 15 on page 29 are examples of DS1 performance history screens at the line unit. Table 9 on page 31 describes the acronyms used in the performance history screens. Asterisks indicate performance monitoring from the previous day.

Monitor Performance Event Log Config Inventory Report Rlogon Help										
H4TU-R DS1 31-Day History (Page 1 of 3)										
Date	CV-L	ES-L	SES-L	UAS-L	CV-P	ES-P	SES-P	UAS-P	PRM-NE	PRM-FE
01/18	0	0	0	0	0	0	0	86400	-	-
01/19	0	0	0	0	0	0	0	86400	-	-
01/20	0	0	0	0	0	0	0	86400	-	-
01/21	0	0	0	0	0	0	0	86401	-	-
01/22	0	0	0	0	0	0	0	86400	-	-
01/23	0	0	0	0	0	0	0	86400	-	-
01/24	0	0	0	0	0	0	0	86400	-	-
01/25	0	0	0	0	0	0	0	86400	-	-
01/26	0	0	0	0	0	0	0	86400	-	-
01/27	0	0	0	0	0	0	0	86400	-	-
01/28	0	0	0	0	0	0	0	86400	-	-
01/29	0	0	0	0	0	0	0	86400	-	-

Press: (N)ext Page, (P)revious Page, C(l)ear History

Use <Space> to cycle through choices and <Enter> to view

Interface : H4TU-R DS1
Statistics : 31-Day History

ID: xxxx--xxxx--xxxx--xxxx 02/01/2002 12:30:01 H4TU-C System: OK

Figure 13. H4TU-R DS1 31-Day Performance History

Monitor Performance <u>E</u> vent Log <u>C</u> onfig <u>I</u> nventory <u>R</u> eport <u>R</u> logon <u>H</u> elp								
H4TU-C DS1 25-Hour History (Page 1 of 9)								
Time	CV-L	ES-L	SES-L	UAS-L	CV-P	ES-P	SES-P	UAS-P
*15:15	0	0	0	0	0	0	0	900
*15:30	0	0	0	0	0	0	0	900
*15:45	0	0	0	0	0	0	0	900
*16:00	0	0	0	0	0	0	0	900
16:15	0	0	0	0	0	0	0	900
16:30	0	0	0	0	0	0	0	900
16:45	0	0	0	0	0	0	0	900
17:00	0	0	0	0	0	0	0	900
17:15	0	0	0	0	0	0	0	900
17:30	0	0	0	0	0	0	0	900
17:45	0	0	0	0	0	0	0	900
18:00	0	0	0	0	0	0	0	900

Press: (N)ext Page, (P)revious Page, C(l)ear History

Use <Space> to cycle through choices and <Enter> to view

Interface : H4TU-C DS1
 Statistics : 25-Hour History
 ID: xxxx--xxxx--xxxx--xxxx 02/01/2002 12:30:01 H4TU-C System: OK

Figure 14. H4TU-C DS1 25-Hour Performance History

Monitor Performance <u>E</u> vent Log <u>C</u> onfig <u>I</u> nventory <u>R</u> eport <u>R</u> logon <u>H</u> elp								
H4TU-C DS1 48-Hour History (Page 1 of 4)								
Time	CV-L	ES-L	SES-L	UAS-L	CV-P	ES-P	SES-P	UAS-P
*17:00	0	0	0	0	0	0	0	3600
*18:00	0	0	0	0	0	0	0	3600
*19:00	0	0	0	0	0	0	0	3600
*20:00	0	0	0	0	0	0	0	3600
*21:00	0	0	0	0	0	0	0	3600
*22:00	0	0	0	0	0	0	0	3600
*23:00	0	0	0	0	0	0	0	3600
*00:00	0	0	0	0	0	0	0	3600
*01:00	0	0	0	0	0	0	0	3600
*02:00	0	0	0	0	0	0	0	3600
*03:00	0	0	0	0	0	0	0	3600
*04:00	0	0	0	0	0	0	0	3600

Press: (N)ext Page, (P)revious Page, C(l)ear History

Use <Space> to cycle through choices and <Enter> to view

Interface : H4TU-C DS1
 Statistics : 48-Hour History
 ID: xxxx--xxxx--xxxx--xxxx 02/01/2002 12:30:01 H4TU-C System: OK

Figure 15. H4TU-C DS1 48-Hour Performance History

Examples of current statistics screens are shown below. **Figure 16** and **Figure 17** show statistics for the DS1 interface at the remote unit and line unit, respectively. These screens report 1-day, 1-hour, and 15-minute statistics. Refer to **Table 9** on page 31 for descriptions of the kinds of errors reported on these screens.

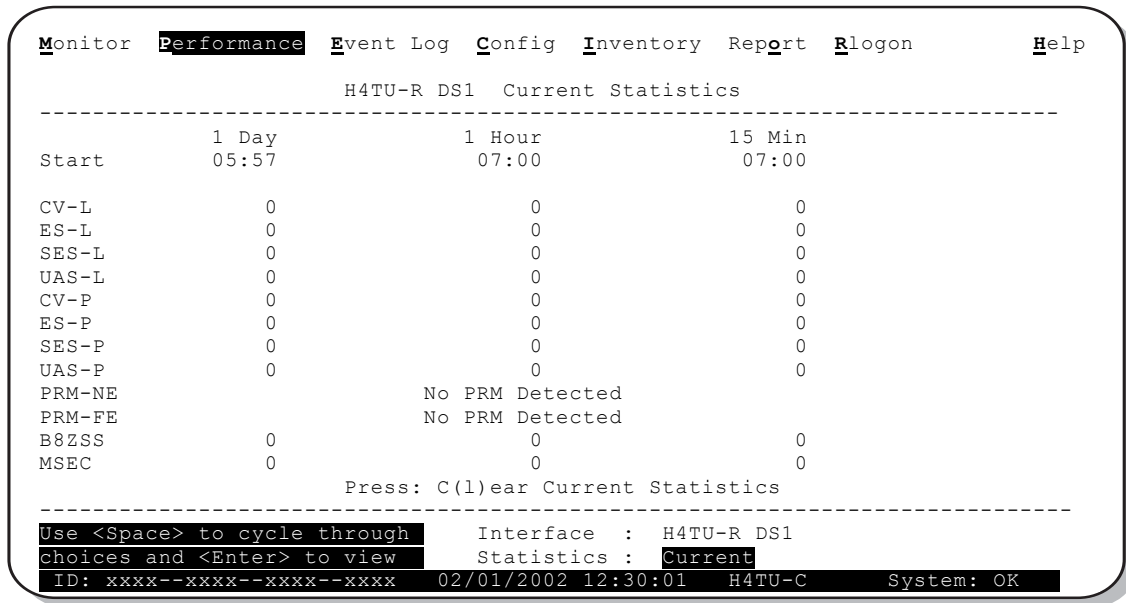

Figure 16. H4TU-R DS1 Current Statistics

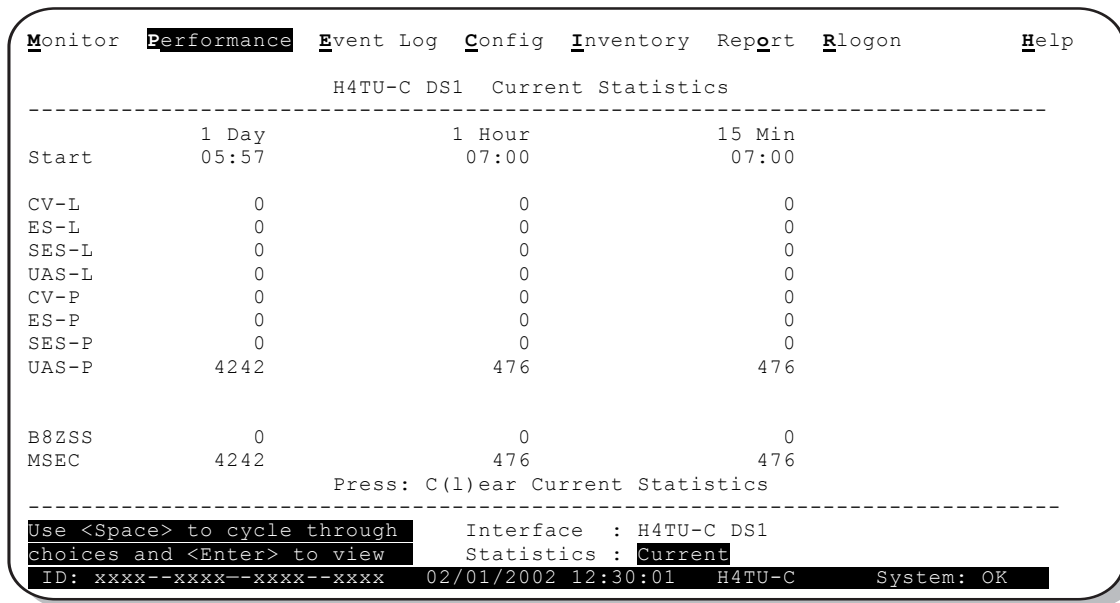

Figure 17. H4TU-C DS1 Current Statistics

Table 9. Acronyms Used on the DS1 Performance History Screens

Acronym	Description	Acronym	Description
CV-L	Code Violation - Line Total BPV count.	SES-P	Severely Errored Seconds - Path Seconds with SES or CRC(ESF) ≥ 320 or $FE^{(a)}(SF) \geq 8 (F_T + F_S)$.
ES-L ^(b)	Errored Seconds - Line Seconds with BPV ≥ 1 .	UAS-P	Unavailable Seconds - Path A second of unavailability based on SES-P or AIS ≥ 1 .
SES-L	Severely Errored Seconds - Line Seconds with BPV plus EXZ ≥ 1544 or LOS ≥ 1 .	PRM-NE ^(c)	Performance Report Messaging - Near End The PRM from CPE indicates errors, and the signal received from the network at the remote is error-free.
UAS-L	Unavailable Seconds - Line Seconds with LOS ≥ 1 .	PRM-FE ^(c)	Performance Report Messaging - Far End The PRM from the network indicates errors, and the signal received from the CPE is error-free.
CV-P	Code Violation - Path Total count of SF frame bit (FB) errors or CRC(ESF) errors.	B8ZSS ^(d)	B8ZS Errored Seconds Seconds with B8ZS detection when AMI option is active.
ES-P ^(e)	Errored Seconds - Path Seconds with SEF ^(f) , CRC (ESF), or $FE^{(a)}(SF) \geq 1$.	MSEC ^(d)	Monitored Seconds of the current (15-minute/1-hour/1-day) screen.

(a) FE is a frame bit error.

(b) Line (L) refers to the AMI DS1 line used to transport the payload.

(c) Only displays on H4TU-R Performance History screens.

(d) Displays on the DS1 Current Statistics screens.

(e) Path (P) refers to the total framed payload being transported between two points.

(f) Severely Errored Frame—Two or more frame bit errors occurring in a 0.75 ms interval for SF or a 3 ms interval for ESF.

Performance History at the HDSL4 Interface

The HDSL4 interface has 31-day, 48-hour, 25-hour, and current statistic screens for the H4TU-C. Figure 18 and Figure 19 below are examples of 31-day and 48-hour performance history screens. Figure 20 on page 33 is an example of a 25-hour performance history screen. Refer to Table 10 on page 34 for descriptions of the kinds of errors reported on all HDSL4 performance screens. Asterisks indicate performance monitoring from the previous day.

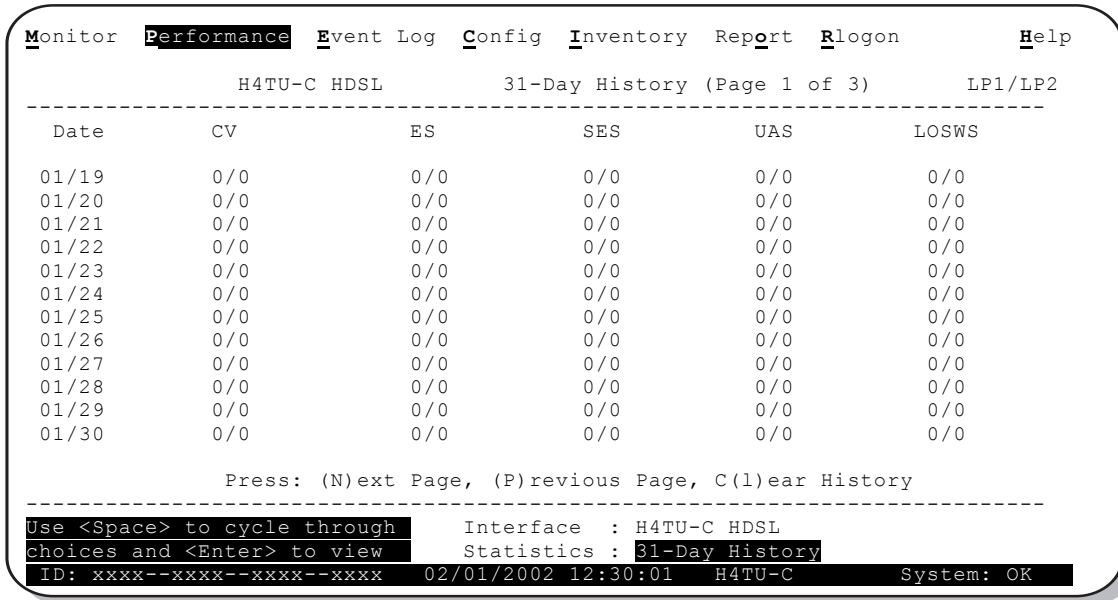

Figure 18. H4TU-C HDSL (Loop 1/Loop 2) 31-Day Performance History

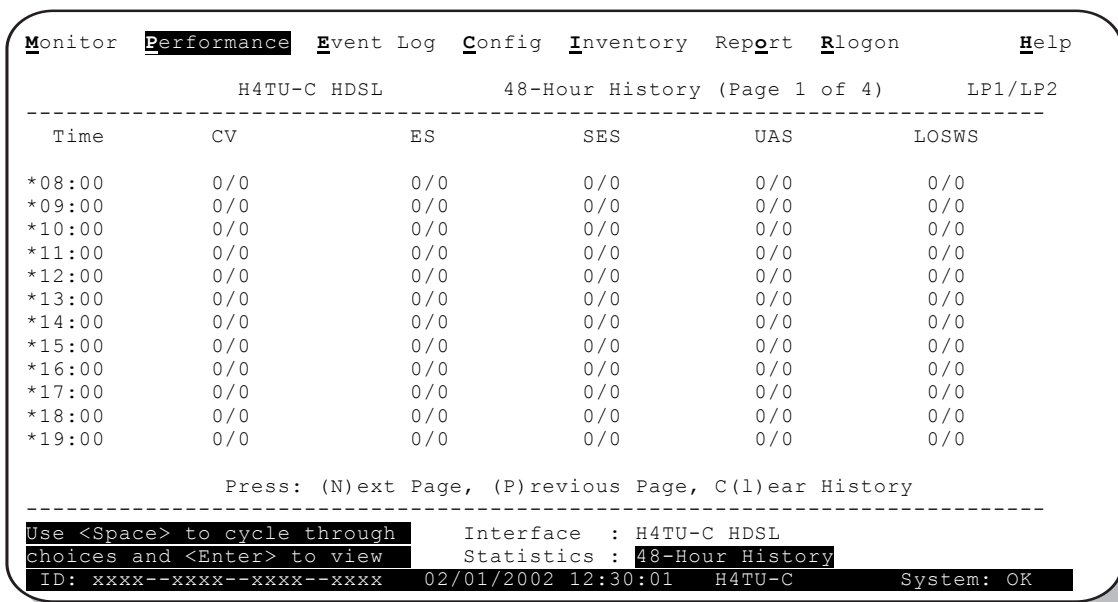

Figure 19. H4TU-C HDSL (Loop 1/Loop 2) 48-Hour Performance History

Monitor Performance Event Log Config Inventory Report Rlogon Help					
H4TU-C HDSL			25-Hour History (Page 1 of 9)		LP1/LP2
Time	CV	ES	SES	UAS	LOSWS
*06:45	0/0	0/0	0/0	0/0	0/0
*07:00	0/0	0/0	0/0	0/0	0/0
*07:15	0/0	0/0	0/0	0/0	0/0
*07:30	0/0	0/0	0/0	0/0	0/0
07:45	0/0	0/0	0/0	0/0	0/0
08:00	0/0	0/0	0/0	0/0	0/0
08:15	0/0	0/0	0/0	0/0	0/0
08:30	0/0	0/0	0/0	0/0	0/0
08:45	0/0	0/0	0/0	0/0	0/0
09:00	0/0	0/0	0/0	0/0	0/0
09:15	0/0	0/0	0/0	0/0	0/0
09:30	0/0	0/0	0/0	0/0	0/0

Press: (N)ext Page, (P)revious Page, C(l)ear History

Use <Space> to cycle through Interface : H4TU-C HDSL
 choices and <Enter> to view Statistics : 25-Hour History
 ID: xxxx--xxxx--xxxx--xxxx 02/01/2002 12:30:01 H4TU-C System: OK

Figure 20. H4TU-C HDSL (Loop 1/Loop 2) 25-Hour Performance History

Figure 21 shows statistics for the HDSL4 interface at the H4TU-C. This screen reports 1-day, 1-hour, and 15-minute statistics. Refer to Table 10 on page 34 for descriptions of the kinds of errors reported on this screen.

Monitor Performance Event Log Config Inventory Report Rlogon Help					
H4TU-C HDSL			Current Statistics		LP1/LP2
	1 Day	1 Hour	15 Min		
Start	05:57	07:00	07:30		
CV	0/0	0/0	0/0		
ES	0/0	0/0	0/0		
SES	0/0	0/0	0/0		
UAS	0/0	0/0	0/0		
LOSWS	0/0	0/0	0/0		
	Margin (dB)	LA (dB)	INSL (dB)		
Hi	16/17				
Cur	14/16	0/0	0/0		
Low	13/13				

Press: C(l)ear Current Statistics

Use <Space> to cycle through Interface : H4TU-C HDSL
 choices and <Enter> to view Statistics : Current
 ID: xxxx--xxxx--xxxx--xxxx 02/01/2002 12:30:01 H4TU-C System: OK

Figure 21. H4TU-C HDSL (Loop 1/Loop 2) Current Statistics

Table 10. *Acronyms Used on the HDSL4 Performance History Screens*

Acronym	Description
CV	Code Violation Total count of HDSL4 CRC errors
ES	Errored Seconds Seconds with HDSL4 CRC ≥ 1 or LOSW ≥ 1
SES	Severely Errored Seconds Seconds with HDSL4 CRC ≥ 50 or LOSW ≥ 1
UAS	Unavailable Seconds Based on 10 contiguous SES occurrences
LOSWS	Loss of Sync Word Second Seconds with LOSW ≥ 1

USING THE PERFORMANCE SCREENS TO VIEW ALARM DATA

To access the alarm history screens:

- 1 Press **P** to select the Performance screen.
- 2 Press the **SPACEBAR** to select an interface (**H4TU-C DS1**, **H4TU-R DS1**, **H4TU-C HDSL**, **H4DU-1 NET HDSL**, **H4DU-1 CPE HDSL**, **H4DU-2 NET HDSL**, **H4DU-2 CPE HDSL**, or **H4TU-R HDSL**), then press **ENTER**.
- 3 Press the **SPACEBAR** until **Alarm History** is selected, then press **ENTER**. (To clear the selected alarm history screen, press **L**.)

Alarm History at the DS1 Interface

The Alarm History screen reports DS1 statistics for the H4TU-C (Figure 22) and the H4TU-R (Figure 23 on page 36) on a continuous basis. The types of alarms reported are described in Table 11 on page 36. Current alarms are shown in reverse video.

```

Monitor Performance Event Log Config Inventory Report Rlogon Help
                H4TU-C DS1 Alarm History
-----
Alarm      First          Last          Status      Count
LLOS       01/30/02
LAIS
DBER
LOF        01/30/02
ALARM      12
OK         0
OK         7
OK         0

Press: C(l)ear Alarm History
-----
Use <Space> to cycle through      Interface : H4TU-C DS1
choices and <Enter> to view       Statistics : Alarm History
ID: xxxx--xxxx--xxxx--xxxx      02/01/2002 12:30:01 H4TU-C      System: Alarm

```

Figure 22. H4TU-C DS1 Alarm History Screen

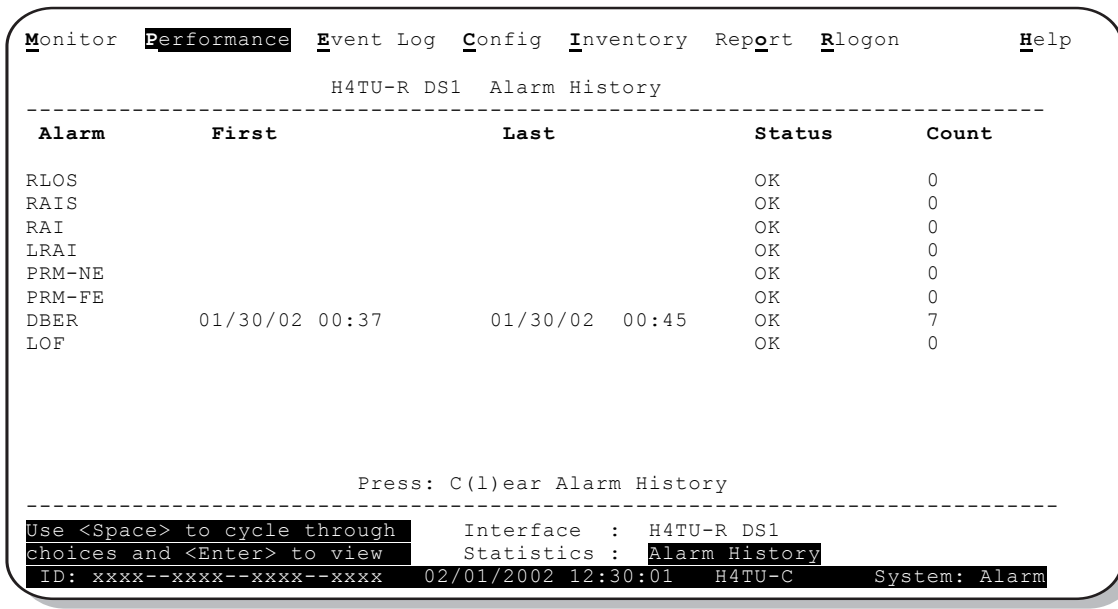

Figure 23. H4TU-R DS1 Alarm History Screen

Table 11. DS1 Alarm Descriptions

Screen Alarm	Front-Panel Alarm	Description
H4TU-C DS1 Alarms (Figure 22 on page 35)		
LLOS ^(a)	LLOS	Line (Unit) Loss of Signal—Loss of the H4TU-C DSX-1 input signal.
LAIS ^(a)	LAIS	Line Alarm Indication Signal—Indicates an AIS (unframed all ones) pattern is being received at the H4TU-C DS1 input port.
DBER	xxx-DBER	Bit Error Rate—The DS1 BER has exceeded the built-in 24-hour threshold limits of approximately 10 ⁻⁶ . (xxx denotes either TUC or TUR.)
LOF	xxx-LOF	Loss of Frame—Indicates the incoming DS1 frame pattern is other than the one selected, ESF or SF, by the FRMG option. Only occurs if the FRMG option is set to SF or ESF. (xxx denotes either TUC or TUR.)
H4TU-R DS1 Alarms (Figure 23 on this page)		
RLOS ^(b)	RLOS	Remote (Unit) Loss of Signal—Loss of the H4TU-R DS1 input signal.
RAIS	RAIS	Remote Alarm Indication Signal—Indicates an AIS (unframed all ones) pattern is being received at the H4TU-R DS1 input port. By default AIS-CI ^(b) is sent towards the network (see Figure 27 on page 45)
RAI	RRAI	Remote RAI - Remote Alarm Indication at the H4TU-R—Indicates an RAI alarm (yellow) from the CPE with errors from the line unit or network.
LRAI	LRAI	Line (Clear) Remote Alarm Indication—An RAI condition is detected at the remote and the signal from the line unit is error-free. RAI signal is transmitted towards the network.
PRM-NE	PRMN	Performance Report Messaging - Near End—The count of the PRM-NE register at the H4TU-R exceeds the 10 ⁻⁶ BER threshold at 648 events since 12:00:00 AM.
PRM-FE	PRMF	Performance Report Messaging - Far End—The count of the PRM-FE register at the H4TU-R exceeds the 10 ⁻⁶ BER threshold at 648 events since 12:00:00 AM.
DBER	xxx-DBER	Bit Error Rate—The DS1 BER has exceeded the built-in 24-hour threshold limits of approximately 10 ⁻⁶ . (xxx denotes either TUC or TUR.)
LOF	xxx-LOF	Loss of Frame—Indicates the incoming DS1 payload does not contain the specific frame pattern, ESF or SF, selected by the FRMG option. Only occurs if the FRMG option is set to SF or ESF. (xxx denotes either TUC or TUR.)

(a) This is a DS1-specific alarm that also issues a minor alarm (sent to the management unit or the backplane), if enabled.
 (b) AIS-CI is a modified AIS alarm pattern. Equipment not suited to detect AIS-CI still detects this signal as an AIS. AIS-CI is sent toward the network indicating that an LOS (RLOS) or AIS (RAIS) has been received from the CPE.

Alarm History at the HDSL4 Interface

The HDSL4 Alarm History screens report alarms for the HDSL4 interface at the H4TU-C and H4TU-R. Figure 24 shows the H4TU-C HDSL4 alarm history. Table 12 describes the alarms that are reported at the H4TU-C or H4TU-R.

Alarm	First	Last	Status	Count
LOSW-LP1	01/15/02 16:45	01/15/02 16:45	OK	1
MAL -LP1	01/15/02 16:44	01/15/02 16:44	OK	1
LA -LP1			OK	0
HBER-LP1			DISABLED	0
LOSW-LP2	01/15/02 16:45	01/15/02 16:45	OK	1
MAL -LP2			OK	0
LA -LP2			OK	0
HBER-LP2			DISABLED	0
SHORT			OK	0
GND			OK	0
OPEN			OK	0

Press: C(l)ear Alarm History

Use <Space> to cycle through choices and <Enter> to view

Interface : H4TU-C HDSL
Statistics : Alarm History

ID: xxxx--xxxx--xxxx--xxxx 02/01/2002 12:30:01 H4TU-C System: Alarm

Figure 24. H4TU-C HDSL Alarm History Screen

Table 12. HDSL4 Alarm Descriptions

Screen Alarm	Front-Panel Alarm	Description
HDSL4 Alarms at the H4TU-C and H4TU-R		
LOSW	SPN n -LOSW	Loss of Sync Word—The HDSL4 loop has lost synchronization.
MAL	xxxx-MALx	Margin—The margin on the HDSL4 loop has dropped below the minimum threshold value set for the system. xxxx denotes TUC, TUR, or first (DU1U/DU1D) or second (DU2U/DU2D) doubler HDSL4 upstream or downstream interface. If TUC and TUR occur at the same time, then TUC displays. The single x indicates Loop 1 or Loop 2.
LA	xxxx-LAx	Loop Attenuation—The attenuation on the HDSL4 loop has exceeded the maximum value set for the HDSL4 loop attenuation threshold. xxxx denotes TUC, TUR, or first (DU1U/DU1D) or second (DU2U/DU2D) doubler HDSL4 upstream or downstream interface. If TUC and TUR occur at the same time, then TUC displays. The single x indicates Loop 1 or Loop 2.
HBER	xxxx-HBRx	Block Error Rate—The HDSL4 BER has exceeded the set threshold limits of 10^{-6} or 10^{-7} . xxxx denotes TUC, TUR, or first (DU1U/DU1D) or second (DU2U/DU2D) doubler HDSL4 upstream or downstream interface. If TUC and TUR occur at the same time, then TUC displays. The single x indicates Loop 1 or Loop 2.
HDSL4 Alarms at the H4TU-C only		
SHORT ^(a)	PWR FEED SHRT	Indicates a short between Loop 1 and Loop 2 of the HDSL4 pair.
GND ^(a)	PWR FEED GND	One of the HDSL4 loops is grounded.
OPEN ^(a)	PWR FEED OPEN	Indicates a line power open condition.

(a) Displays only at the H4TU-C HDSL interface.

USING THE EVENT LOG TO TRACK SYSTEM EVENTS

To view a running log of system events, press **E** to select the Event Log. The Event Log displays the date and time of the 100 most recent events (the most recent displayed first) and provides a description of each event. See [Table 13 on page 39](#) for an alphabetical listing of all possible event log messages.

- Press **N** or **P** to page through the event log.
- Press **T** to return to the top of the log.
- Press **L** to clear the event log.

```

Monitor Performance Event Log Config Inventory Report Rlogon Help
-----
System Event Log (Page 1 of 7)
-----
#   Origin                Date and Time          Entry
1   Line Unit              01/15/02 16:44:41      MAL Alarm TUC Lp 1: End
2   Line Unit              01/15/02 16:44:41      LOSW Alarm span 1: End
3   Line Unit              01/15/02 16:44:39      MAL Alarm TUC Lp 1: Begin
4   Managment Host        01/15/02 16:45:10      Time set to 16:44:18
5   Line Unit              01/15/02 16:45:03      DS1 AIS Alarm: Begin
6   Line Unit              01/15/02 16:45:03      LOSW Alarm span 1: Begin
7   Line Unit              01/15/02 00:00:00      Time set to 16:45:00
8   Line Unit              01/15/02 16:15:33      MAL Alarm TUC Lp 1: End
9   Line Unit              01/15/02 16:15:33      LOSW Alarm span 1: End
10  Line Unit              01/15/02 16:15:31      MAL Alarm TUC Lp 1: Begin
11  Line Unit              01/15/02 16:15:03      DS1 AIS Alarm: Begin
12  Line Unit              01/15/02 16:15:03      LOSW Alarm span 1: Begin
13  Line Unit              01/15/02 00:00:00      Time set to 16:15:00
14  Line Unit              01/15/02 14:53:17      MAL Alarm TUC Lp 2: End
15  Line Unit              01/15/02 14:53:16      LOSW Alarm span 1: End

Press: (N)ext Page, (P)revious Page, (T)op of Log, C(l)ear Log
ID: xxxx--xxxx--xxxx--xxxx 02/01/2002 12:30:01 H4TU-C System: OK

```

Figure 25. System Event Log

Table 13. *Event Log Entry Messages List*

Event Log Messages
HDSL4 DC pair open begins/ends on any segment
HDSL4 Ground fault begins/ends on any segment
H4TU-C Power up/down
H4TU-R Power up/down
HDSL4 margin alarm (threshold crossed) on any HDSL4 Interface (I/F)
HDSL4 loop attenuation (threshold crossed) on any HDSL4 I/F
HDSL4 HBER alarm (threshold crossed) on any HDSL4 I/F
HDSL4 LOSW begins/ends on any segment
CPE DBER alarm (1-day threshold of any PM data crossed—except PRM-NE or PRM-FE)
CPE PRM-NE BER alarm (<i>at the remote only</i> : 1-day PRM-NE threshold crossed: trouble on CPE receive)
NTWK PRM-FE BER alarm (<i>at the remote only</i> : 1-day PRM-FE threshold crossed: trouble on NTWK far end)
NTWK DBER alarm (1-day threshold of any PM data crossed)
CPE DS1 LOS begins/ends
CPE DS1 AIS begins/ends
NTWK DS1 LOS begins/ends
NTWK DS1 AIS begins/ends
TX RAI-CI begins/ends (RAI-CI sent from the remote towards the network)
RAI begins/ends
Any HDSL4 PM register reset
Any DS1 PM register reset
Any DS1 Alarm History reset
Any HDSL4 Alarm History reset
Event Log reset
Current statistics reset
Master zero reset
Any provisioning option change: <provisioning mnemonic>: changed from <old> to <new>
Any Loop Up (any segment)
Any Loop Down (any segment)
Power Feed Short begins / ends

USING THE REPORT MENU

The Report menu (Figure 26) provides screens containing status and performance monitoring data for line and remote units which can be downloaded to a file for analysis or future reference. Table 14 on page 41 describes the four types of reports provided by the Report menu.

To select each individual report, do the following:

- 1 Press **O** to select Report menu.
- 2 Press the **SPACEBAR** to select a report type and print mode.
 - Continuous Print Mode generates a non-stop version of the report.
 - Page Mode generates a page-by-page version of the report for easy viewing on the screen.
- 3 Use your terminal emulation software (HyperTerminal or Procomm) to capture the selected report to your printer. Press **ENTER** to generate. (If Page Mode is selected, press the **SPACEBAR** to continue or **ESC** to quit.)
- 4 End the captured report.
- 5 Press **CTRL + R** to refresh the Report menu screen.



```
Monitor Performance Event Log Config Inventory Report Rlogon Help

Report Type : Full Report
Print Mode : Continuous
Please select report type and print mode by pressing <Space>, then start
terminal logging and press <Enter> to generate the report.

ID: xxxx--xxxx--xxxx--xxxx 02/01/2002 12:30:01 H4TU-C System: OK
```

Figure 26. Report Menu - Full Report

Table 14. Report Types

Type	Contains the following information:
Full Report	<ul style="list-style-type: none"> • Circuit and unit identifications • Product information • System configuration • Current performance statistics • Alarm history • Performance history • System event log
Short Report	<ul style="list-style-type: none"> • Circuit and unit identifications • Product information • System configuration • Current performance statistics
System Information Report	<ul style="list-style-type: none"> • Circuit and unit identifications • Product information • System configuration
Event Report	<ul style="list-style-type: none"> • Circuit and unit identifications • Product information • System event log

TESTING

This section provides information about front-panel system alarms, LOS and AIS response, the OCT55 test procedure, and loopback testing.

SYSTEM ALARMS

Table 15 summarizes all possible system alarms in order of priority as they appear on the front panel. When multiple alarms occur, the front-panel display only reports the highest priority alarm. The alarm history screens display alarms also, but provide greater detail (see “Using the Performance Screens to View Performance Data” on page 28). Alarms that are not inhibited will drive the front-panel Status LED to a flashing red alarm state.

Table 15. Front-Panel System Alarms

Front-Panel Message ^(a)	Alarm	Description	To Inhibit:
PWR FEED SHRT ^(b)	Power Feed Short	A short exists between Loop 1 and Loop 2 of the HDSL4 pair.	Cannot be inhibited.
PWR FEED GND ^(b)	Power Feed Ground	One of the HDSL4 loops is grounded.	Cannot be inhibited.
PWR FEED OPEN ^(b)	Power Feed Open	A line power open condition exists.	Cannot be inhibited.
SPN n -LOSW	Span(n)-Loss of Sync Word ^(c)	The HDSL4 loop has lost synchronization. The span closest to the network has highest priority.	Cannot be inhibited.
LLOS	Line (Unit) Loss of Signal	Loss of the DSX-1 input signal.	Cannot be inhibited.
RLOS	Remote (Unit) Loss of Signal	Loss of the H4TU-R DS1 input signal.	Disable the RDA (Remote Disconnect Alarm) option. This prevents an LOS condition at the DS1 input to a H4TU-R from activating pin H. The front-panel Status LED still flashes red and the ALRM RLOS message displays to alert you of the LOS state. LOS is sent towards the network from the H4TU-C. This option prevents the common occurrences of a CPE LOS condition from generating recurring alarms and AIS payloads.
LAIS	Line Alarm Indication Signal	Indicates an AIS (unframed all ones) pattern is being received at the H4TU-C DS1 input port.	Cannot be inhibited.
RAIS	Remote Alarm Indication Signal	Indicates an AIS (unframed all ones) pattern is being received at the H4TU-R DS1 input port.	Cannot be inhibited.
LRAI	Line RAI—Remote Alarm Indication at the H4TU-R (Net signal does not have errors.)	Indicates an RAI alarm (yellow) from the CPE with an error-free signal from the line unit or network. RAI signal is transmitted towards the network.	Cannot be inhibited.

Continued

Table 15. Front-Panel System Alarms (Continued)

Front-Panel Message ^(a)	Alarm	Description	To Inhibit:
RRAI	Remote RAI—Remote Alarm Indication at the H4TU-R (Net signal has errors.)	Indicates an RAI alarm (yellow) from the CPE with errors from the line unit or network.	Cannot be inhibited.
xxx-DBER	DS1 Bit Error Rate	The DS1 BER has exceeded the set 24-hour threshold limit of approximately 10^{-6} . (xxx denotes either TUC or TUR. If TUC and TUR occur at the same time, then TUC displays.)	Select DIS for the DBER system option.
xxx-LOF	Loss of Frame	The DS1 input does not contain the ESF or SF frame pattern setting of the FRMG option. (xxx denotes either TUC or TUR. If TUC and TUR occur at the same time, then TUC displays.)	Change FRMG option to AUTO or UNFR.
PRMN	Performance Report Messaging - Near End	H4TU-R PRM-NE BER threshold has been exceeded.	Set DBER threshold to DIS.
PRMF	Performance Report Messaging - Far End	H4TU-R PRM-FE BER threshold has been exceeded.	Set DBER threshold to DIS.
xxxx-HBR _x ^(d)	HDSL4 Block Error Rate	The HDSL4 BER has exceeded the set threshold limits of 10^{-6} or 10^{-7} . xxxx denotes TUC, TUR, or first (DU1U/DU1D) or second (DU2U/DU2D) doubler HDSL4 upstream or downstream interface. If TUC and TUR occur at the same time, then TUC displays. The single x indicates Loop 1 or Loop 2.	Select NONE for the HBER system option.
xxxx-MAL _x ^(d)	Margin Alarm	The margin on the HDSL4 loop has dropped below the minimum threshold value set for the system. xxxx denotes TUC, TUR, or first (DU1U/DU1D) or second (DU2U/DU2D) doubler HDSL4 upstream or downstream interface. If TUC and TUR occur at the same time, then TUC displays. The single x indicates Loop 1 or Loop 2.	Set the Margin Alarm Threshold option to zero.
xxxx-LAX ^(d)	Loop Attenuation	The attenuation on the HDSL4 loop has exceeded the maximum value set for the HDSL4 loop attenuation threshold. xxxx denotes TUC, TUR, or first (DU1U/DU1D) or second (DU2U/DU2D) doubler HDSL4 upstream or downstream interface. If TUC and TUR occur at the same time, then TUC displays. The single x indicates Loop 1 or Loop 2.	Set the HDSL4 Loop Attenuation Threshold option to zero.

(a) The message, ALRM, displays prior to any alarm message.

(b) Message displays repeatedly as long as the alarm condition exists and is not included in the priority order.

(c) When the HDSL4 loop loses sync word (LOSW), a system alarm condition exists. However, since the H4TU-C-319 enters the acquiring mode, the front-panel status LED flashes red, and the ACQ or SIG message displays instead of the ALRM message.

(d) Only these alarms assert the System Alarm bus on pin H of the card-edge connector, if the ALM option is set to enabled.

Alarm Option for DLC Feed

To improve HDSL4 compatibility with the switch-to-protect features used in DLC feeder applications, the H4TU-C-319 has an Alarm Pattern (ALMP) option that allows you to select either an AIS or LOS DS1 output payload for the following alarms:

- LOSW on any loop
- LOS DS1

Retiring System Alarms

To retire a system alarm, press the SEL pushbutton to execute an Alarm Cutoff (ACO). An ACO turns the alarm off and replaces the ALRM message with an ACO message. The second part of the ALRM message, which defines the cause of the alarm, remains. Both parts of the message remain until the alarm condition clears or another higher priority alarm occurs.

Remote LOS and AIS Response

Figure 27 shows the different ways the H4TU-R can respond to the network, depending on the configuration of the NLBP, TLOS, RDA, and ALMP configuration options described in Table 5 on page 19 and Table 6 on page 20.

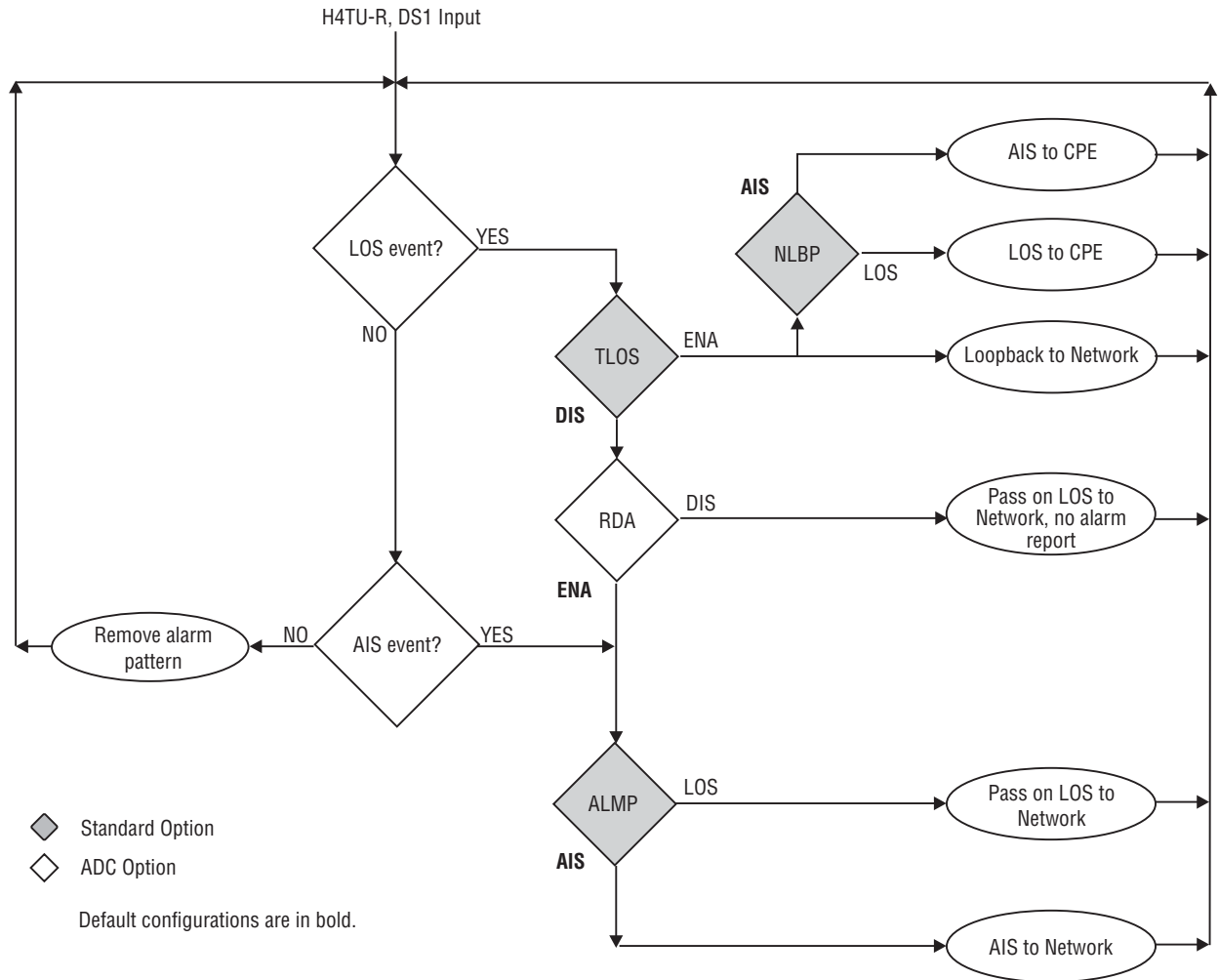

Figure 27. H4TU-R LOS and AIS Response Priorities

OCT55 TEST PATTERN WITH AMI LINE CODE

The OCT 55 test pattern can be used in unframed mode to stress the system and verify data integrity. In an SF or ESF framing mode, excessive zero anomalies may occur, which causes the H4TU-C to report ES, SES, and UAS errors according to ANSI T1.231-1997.

LOOPBACK OPERATION

HDSL4 has a family of loopback options for analyzing circuit functionality. The loopback signal is transmitted and returned to the sending device for comparison. This allows you to verify the integrity of the HDSL4 channels to the H4TU-C, the H4TU-C DSX-1 interface, and the DS1 channels to the customer.

Loopback options include:

- Generic Loopback (GNLB) options, including the SmartJack (SMJK) option (see Table 16 on page 51)
- A3LB Addressable Repeater Loopback command (see Table 17 on page 52)
- A5LB Addressable Repeater Loopback command (see Table 18 on page 53)

Loopback commands can be initiated by:

- Selecting the loopback type using the MODE and SEL pushbuttons on the H4TU-C front panel or the manual loopback (LBK) pushbutton on the H4TU-R front panel
- Selecting the loopback type from the Monitor menu when connected to the craft port of the H4TU-C or H4TU-R
- Entering the loopback code (exceptions are COLB and RULB) into the test equipment connected to the H4TU-C or H4TU-R

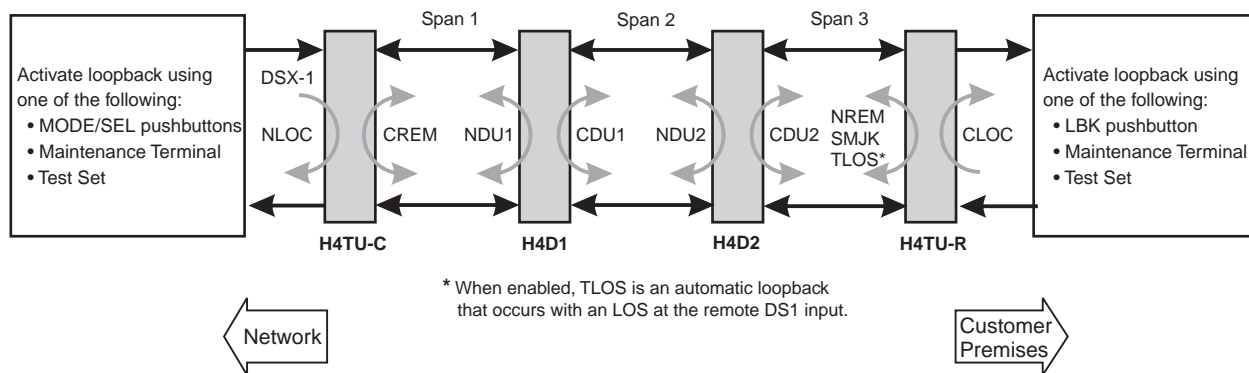

Figure 28. Loopback Summary



ADC HDSL4 supports multiple loopbacks, but a single loopback is the preferred method. HDSL4 automatically rejects activation of closed loop loopbacks. For example, an NREM and CREM cannot be activated at the same time.

Generic Loopback Commands

The HDSL4 Generic Loopback (GNLB) commands allow you to use inband codes to loop up either NLOC (4-in-7) or NREM (3-in-7) towards the network. In addition, these inband codes loop up CREM (6-in-7) or CLOC (5-in-7) towards the customer. Either loopup condition can be terminated (looped down) with the 3-in-5, SMJK loopdown code. All inband codes must be present for at least 5 seconds before the HDSL4 system responds. TLOS is a logic loopback caused by loss of the DS1 input from the CI.

Figure 29 on page 50 summarizes the available loopbacks in the system, and Table 16 summarizes the HDSL4 generic loopback commands. See “GNLB Test Procedures” on page 51 for the test procedures that apply



HDSL4 systems feature the SmartJack option, which can emulate a Network Interface Device (NID) for the purpose of loopback testing of the HDSL4 circuit. SMJK and NREM loopbacks perform the same functions but their initiation differs. SMJK indicates that the loopback was initiated by the 2-in-5 inband command. NREM, on the other hand, is initiated by the 3-in-7 inband command or by a command issued from the maintenance terminal or the MODE and SEL pushbuttons.

Use the inband commands to enable or disable the SMJK loopback options. The H4TU-C-319 system setting is normally enabled to recognize all inband SmartJack loopback commands.

Special Loopback Commands

A3LB and A5LB loopback commands can be sent by a test set connected to the H4TU-C or H4TU-R. See Table 17 on page 52 and Table 18 on page 53 for a list of the commands.

A3LB and A5LB are special, addressable, repeater loopback modes which are supported by the H4TU-C. These loopback modes provide the HDSL4 system with sophisticated maintenance and troubleshooting tools. A3LB and A5LB are patterned after the Westell addressable T1 repeater loopbacks.

The A5LB loopback selection complies with that proposed for HDSL4 systems in the T1E1.4/92 loopback recommendation with the following additions:

- Query loopback
- IOR (Intelligent Office Repeater) power-down
- Four loopback time-out choices
- Initiation from either end
- Repeating bit error signatures
- Alternate query loopback

A5LB does not block the arming code from exiting the H4TU-C-319 into the network. Since A5LB never blocks the arming code from exiting the H4TU-C, the Far-End Activate code is not available in A5LB. A3LB supports the additional (1-in-6) SMJK loopback command.

Manual Loopback Session

A manual loopback session allows you to select any one of the HDSL4 loopbacks listed in [Table 16 on page 51](#) with the exception of SmartJack loopbacks, which can only be issued by inband commands.

Setting the Loopback Time-Out Option (LBTO)

Before initiating a loopback session, verify that the Loopback Time-Out parameter is set to the desired setting.

- 1 Use the MODE and SEL pushbuttons as described in [“Setting Options through MODE and SEL” on page 10](#).
(The loopback time-out parameter is also user-selectable from the Config Menu, Standard Options screen when using a maintenance terminal.)
- 2 Select the desired setting:
 - NONE (time-out disabled)
 - 20 minutes
 - 60 minutes
 - 120 minutes
 - 8 hr
 - 24 hr

Activating Manual Loopback Mode



With the exception of SmartJack, any of the HDSL4 loopbacks can be executed using the MODE and SEL pushbuttons.

When executing a manual loopback session using the MODE and SEL pushbuttons:

- The next loopback option can be displayed by pressing the MODE pushbutton, however, the previously activated loopback remains active until the SEL pushbutton is pressed, which activates the new loopback.
- If neither pushbutton is pressed for a period of 30 seconds and no loopback is in effect, the manual loopback session terminates, and the display returns to normal mode.
- If any loopback is in effect, the 30-second time-out is inhibited. The active loopback and the manual loopback sessions continue until the loopback times out in accordance with the LBTO setting.
- If there is an active loopback, pressing the MODE and SEL pushbuttons for 3 or more seconds terminates any active loopback, ends the manual loopback session, and returns the display to normal mode.

To initiate a manual loopback session:

- 1 Press both the MODE and SEL pushbuttons on the front panel for at least 3 seconds. The following message appears on the front-panel display:
MAN LPBK NLO? (XXXX indicates loopback choices)
- 2 Press SEL to activate NLOC. The display changes to MAN LPBK NLOC.
- 3 Press MODE to advance to the next available loopback:
 - NDx? = Doubler 1 or Doubler 2, if H4D is available
 - NRE? = NREM
 - CRE? = CREM

- CDx? = Doubler 1 or Doubler 2, if H4D is available
- CLO? = CLOC
- COL? = Dual loopback at H4TU-C
- DxL? = Dual loopback at Doubler 1 or Doubler 2, if available
- RUL? = Dual loopback at H4TU-R

4 Press SEL to activate the selected loopback. The previous loopback is terminated.

Once a loopback is selected and activated, the loopback stays active until it times out (based on the LBTO setting). When a loopback times out, the display returns to the normal display mode.

You can terminate loopbacks manually and exit the MAN LPBK mode by simultaneously pressing the MODE and SEL pushbuttons for 3 or more seconds. If no loopback is active, the MAN LPBK mode automatically terminates after 30 seconds.

All loopbacks can be initiated by inband commands in the DS1 payload or by a command from the HDSL4 system (front-panel pushbuttons or maintenance screen selections). Therefore, whenever a loopback is active, the method by which it was activated is indicated in the loopback and status information (Monitor screen) by the annotation HG or PL adjacent to the identified loopback. For example, NREM-HG indicates that the loopback was initiated by the HDSL4 system.



SMJK loopback commands are only activated by inband commands.

LOOPBACK TEST PROCEDURES

The following sections provide step-by-step test procedures for verifying the integrity of the HDSL4 channels at every module location as well as the DS1 channels to the customer and the local DSX-1 interface. [Figure 29 on page 50](#) summarizes the available loopbacks in the system.

General Troubleshooting Tips

If trouble is encountered on the DSX-1 interface of the H4TU-C, verify that the:

- H4TU-C is making a positive connection with its shelf connector.
- H4TU-C internal equalizer is set to the correct distance range per [Table 5 on page 19](#). All equalizers should be set to the distance from the DSX-1 to the shelf.

The transmit and receive DSX-1 ports have splitting access jacks and miniature, 210-series, bridging jacks as shown in [Figure 1 on page 3](#). Connecting one cable between the two (BRG) jacks and another between the two LINE jacks splits the IN and OUT and creates metallic loopbacks towards both the DSX-1 and the H4TU-C-319. If separate plugs are inserted into both LINE jacks with the other end disconnected, the BRG jacks can be used to send and receive test patterns towards the DSX-1.

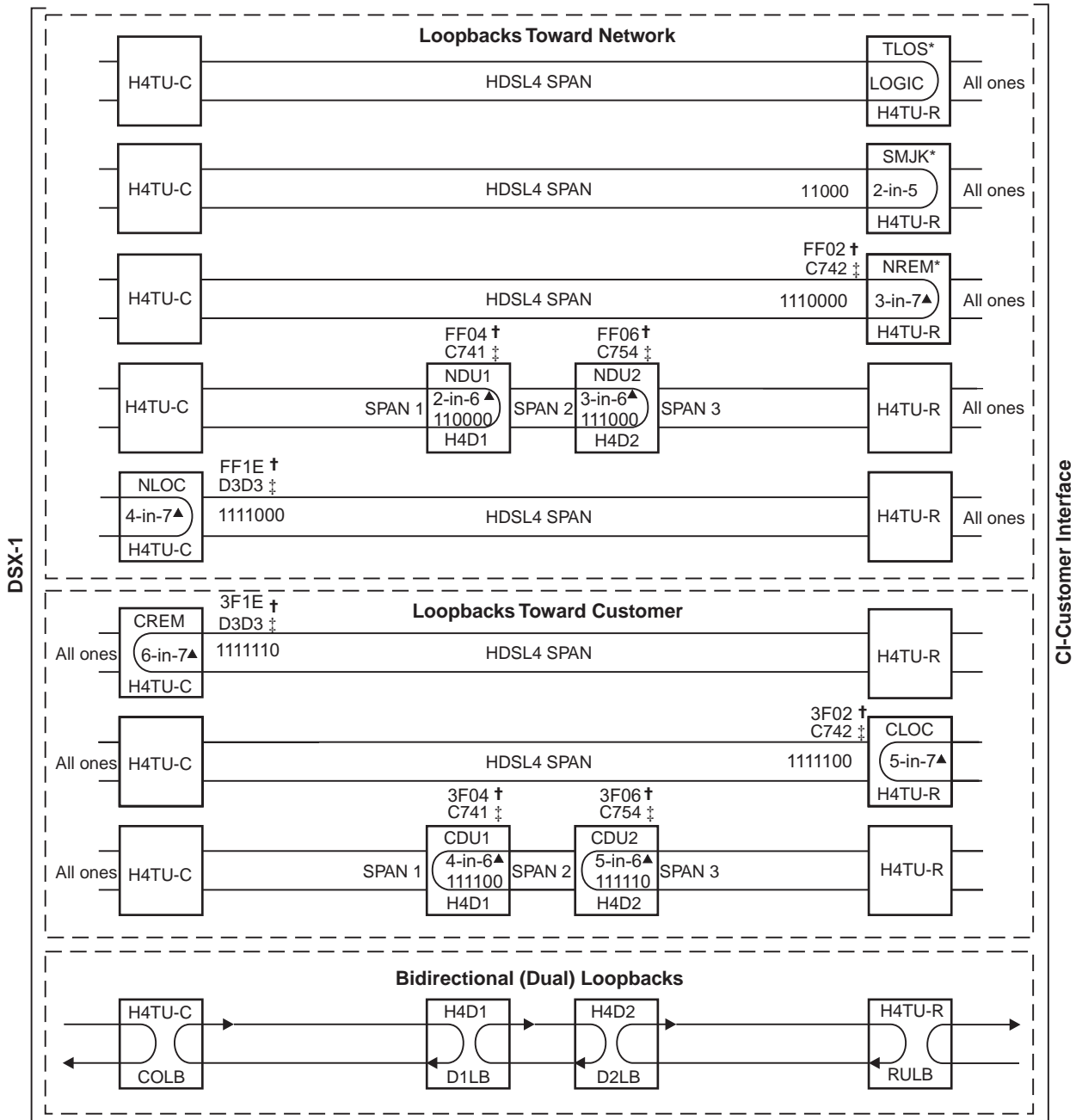

* Set the NLBP option to AIS to send AIS (indicated by an all ones pattern) for any network loopback.

† A3LB loopback codes.

‡ A5LB loopback codes.

▲ GNLB loopback codes.

Figure 29. Loopback Modes

GNLB Test Procedures

Figure 29 on page 50 is a graphical representation of the various loopback configurations with the associated GNLB commands shown. Refer to Table 16 for a description of these commands.

Table 16. Summary of HDSL4 Loopback and Activation Codes

Loopback	Code	Description	Method of Activation		
			Test Set	Craft Port	MODE/SEL
NLOC	1111000 4-in-7	DSX-1 signal is looped back to the network at the H4TU-C.	X	X	X
NREM	1110000 3-in-7	DSX-1 signal is looped back to the network at the H4TU-R.	X	X	X
NDU1	110000 2-in-6	Signal is looped back to the network at H4D1.	X	X	X
CDU1	111100 4-in-6	DS1 signal from customer is looped back to the customer at H4D1.	X	X	X
NDU2	111000 3-in-6	Signal is looped back to the network at H4D2.	X	X	X
CDU2	111110 5-in-6	DS1 signal from customer is looped back tot he customer at H4D2.	X	X	X
D1LB		Dual loopback at H4D1.			X
D2LB		Dual loopback at H4D2.			X
CLOC	1111100 5-in-7	DS1 signal from the customer is looped back to the customer at the H4TU-R.	X	X	X
CREM	1111110 6-in-7	DS1 signal from the customer is looped back to the customer at the H4TU-C.	X	X	X
COLB		Dual loopback at the H4TU-C. DSX-1 signal is looped back to the network at the H4TU-C and DS1 signal from the customer is looped back to the customer at the H4TU-C.			X
RULB		Dual loopback at the H4TU-R. DSX-1 signal is looped back to the network at the H4TU-R and DS1 signal from the customer is looped back to the customer at the H4TU-R.			X
SMJK LpUp (PL)	11000 2-in-5	SmartJack Loopup or NID payload (PL) code. Invokes H4TU-R loopback towards network.	X		
SMJK LpUp (ESF-DL)	1111-1111-0100-1000	SmartJack Loopup or NID (ESF-DL) code. Invokes H4TU-R loopback towards network.	X		
SMJK LpDn (PL)	11100 3-in-5	SmartJack Loopdown or NID payload (PL) code. Removes SMJK, NLOC, NREM, CLOC, and CREM.	X		
SMJK LpDn (ESF-DL)	1111-1111-0010-0100	SmartJack Loopdown or NID (ESF-DL) code. Removes SMJK, NLOC, NREM, CLOC, and CREM.	X		

To perform the GNLB loopback test procedure:

- 1 Have the CO tester send the NREM (3-in-7) inband loopup code for 5 seconds. You should observe the NREM message on the front-panel display. (The Status LED on the front panel should be green, and the loopback mode should also be identified on the Monitor screen.)
- 2 Have the CO tester transmit a DS1 test signal towards the H4TU-C and verify that the returned (looped) signal to the test set is error-free.
- 3 If step 2 fails, have the CO tester transmit the (3-in-5) inband loopdown code.
- 4 Have the CO tester send the NLOC (4-in-7) inband loopup for 5 seconds. You should observe the NLOC message on the front-panel display. (The Status LED on the front panel should be yellow, and the loopback mode should also be identified on the Monitor screen.)
- 5 Repeat Step 2. If the test passes, the problem is in the downstream direction. If it fails, the problem is in the upstream direction.

A3LB Test Procedure

The H4TU-C-319 can be looped back by sending the Addressable Office Repeater (AOR) LPBK activation code 1111-1111-0001-1110 (FF1E) for at least 5 seconds. This causes the H4TU-C to enter the NLOC state. The Loopback Time-Out setting (see “[Setting the Loopback Time-Out Option \(LBTO\)](#)” on page 48) determines the duration of this loopback unless it is overridden by the reception of a second identical 16-bit loopup command before the timer expires. When this time-out override state exists, the only way to loop the H4TU-C down is to issue one of the three loopdown commands listed in [Table 17](#). The automatic time-out mode is restored during subsequent loopback sessions.

[Table 17](#) summarizes the codes required to execute an A3LB Addressable Repeater Loopback command. All code sequences must be present for at least 5 seconds.

Table 17. A3LB Addressable Repeater Loopback Commands

Name	Binary Code ^(a) (Hexadecimal Equivalent)	Description
NLOC	1111-1111-0001-1110 (FF1E)	H4TU-C loopup from NI.
CREM	0011-1111-0001-1110 (3F1E)	H4TU-C loopup from CI.
NREM	1111-1111-0000-0010 (FF02)	H4TU-R loopup from NI.
NDU1	1111-1111-0000-0100 (FF04)	Signal is looped back to the network at H4D1.
CDU1	0011-1111-0000-0100 (3F04)	DS1 signal from customer is looped back to the customer at H4D1.
NDU2	1111-1111-0000-0110 (FF06)	Signal is looped back to the network at H4D2.
CDU2	0011-1111-0000-0110 (3F06)	DS1 signal from customer is looped back tot he customer at H4D2.
D1LB		Dual loopback at H4D1.
D2LB		Dual loopback at H4D2.
CLOC	0011-1111-0000-0010 (3F02)	H4TU-R loopup from CI.
SMJK	11000-11000-11000 ...	H4TU-R loopup from NI.
SMJK	100000 100000 100000 ...	H4TU-R loopup from NI.
SMJK	1111-1111-0100-1000 (FF48)	H4TU-R loopup from NI (ESF-DL).
Loopdown	11100-11100-11100 ...	H4TU-C and H4TU-R loopdown from NI OR CI.
Loopdown	100-100-100 ...	H4TU-C and H4TU-R loopdown from NI OR CI.
Loopdown	1111-1111-0010-0100 (FF24)	H4TU-C and H4TU-R loopdown from NI OR CI (ESF-DL).

(a) The leftmost bit arrives first in all sequences. The detection algorithm functions reliably with a random 10^{-3} Bit Error Ratio (BER) on the facility. The entire arming and loopback sequence can also be initiated at the remote H4TU-R location.

A5LB Test Procedure

Using the codes listed in Table 18, a network tester can activate NLOC or NREM loopbacks (or SMJK, if enabled). A tester at the customer premises can activate CLOC or CREM loopbacks.

Table 18. A5LB Addressable Repeater Loopback Commands

Name	Binary Code ^(a) (Hexadecimal Equivalent)	Description
ARMING or NI LPBK (inband)	11000-11000 ...	Arming code
ARMING or NI LPBK (ESF Data Link)	1111-1111-0100-1000 (FF48)	Arming code
IR LPDN or DISARM (inband)	11100-11100 ...	Disarming code
IR LPDN or DISARM (ESF Data Link)	1111-1111-0010-0100 (FF24)	Disarming code
IOR LPBK (NLOC or CREM) 230-232 bit errors 229-231 bit errors ^(b)	1101-0011-1101-0011 (D3D3)	H4TU-C loopup
ILR-1 LPBK (NDU1 and CDU1 10 bit errors)	1100-0111-0100-0001 (C741)	Doubler-1 loopup
ILR-20 LPBK (NDU2 and CDU2 200 bit errors)	1100-0111-0101-0100 (C754)	Doubler-2 loopup
ILR-2 LPBK (NREM and CLOC 20 bit errors)	1100-0111-0100-0010 (C742)	H4TU-R loopup
ILR-2 LPBK (NREM or CLOC) 20 bit errors ^(c)	NREM—DSX-1 signal is looped back to the network at the H4TU-R. CLOC—DS1 signal from customer is looped back to the customer at the H4TU-R.	1100-0111-0100-0010 (C742)
IR LPDN	1001-0011-1001-0011 (9393)	Loopdown (H4TU-C or H4TU-R)
IR QUERY LPBK	1101-0101-1101-0101 (D5D5)	Query loopback
IR ALTERNATE QUERY LPBK	1101-0101-1110-1010 (D5EA)	Alternate query loopback
TIME-OUT OVERRIDE	1101-0101-1101-0110 (D5D6)	Loopback time-out override
IOR POWER DOWN (H4TU-C) ^(d)	0110-0111-0110-0111 (6767)	Removes HDSL4 line power

- (a) The leftmost bit arrives first in all sequences. The detection algorithm functions reliably with a random 10^{-3} BER on the facility. The entire arming and loopback sequence can also be initiated at the remote H4TU-R location.
- (b) The H4TU-R identifies CREM (and the H4TU-C identifies NLOC) with 231 bit errors, including the frame bits. When framed data is being sent in the Auto framing mode, the number of the 231 bit errors detected by the test set varies from 229 to 231, depending on whether or not the test set counts frame errors as bit errors, and on the number of frame bits contained in the block of 231 error bits. The H4TU-R and H4TU-C generate this bit pattern in a series of discontinuous bursts containing 20-bit errors each, including frame bits. Those test sets that do not count frame error bits as data bit errors will indicate fewer bits than the H4TU-R and H4TU-C transmit for a CI and NI loopback.
- (c) The H4TU-R is assigned the ILR-2 loopback code. It responds with 20 bit errors (excluding the frame bits).
- (d) The IOR Power Down code must remain present for the duration of the power down mode. When this code is removed, the system returns to its normal unlooped and unarmed state.

To perform the A5LB test procedures:

- 1 Send the inband Arming and NI LPBK code 11000 to the H4TU-C for at least 5 seconds.
- 2 Monitor the output of the H4TU-C for the return of the pattern. Return of the pattern indicates one of the following:
 - The H4TU-R has looped up (if the SMJK Loopback option is enabled).
 - An external NID has looped up (if the SMJK Loopback option is disabled), and the H4TU-C and H4TU-R have been armed.
- 3 Verify, if possible, that the H4TU-R Loopback LED is either flashing yellow at four times per second (indicating that the system is armed), or is a steady yellow (indicating that it is both armed and in SMJK loopback). The H4TU-C Status LED also flashes yellow when the system is armed.



If the Arming code is not returned after 5 seconds, the system may be armed, but there is no active loopback.

- 4 Once armed, the H4TU-C can be looped back by sending Intelligent Office Repeater (IOR) LPBK activation code 1101-0011-1101-0011 (D3D3) for at least 5 seconds. You should observe the following activation response pattern in the order presented:
 - 2 seconds of AIS (all ones pattern)
 - 2 seconds of returning data pattern
 - 231 logic errors (including the frame bit) occurring in the returned pattern comprising:
 - 10 errors, if ILR-1 (Doubler 1) was sent
 - 200 errors, if ILR-20 (Doubler 2) was sent
 - 20 errors, if ILR-2 (H4TU-R) was sent
 - Normal looped data

This error pattern repeats every 20 seconds as long as the IOR loopback pattern is being sent. This also applies to ILR, Time-Out Override, and Query commands.



Some Intelligent Repeater (IR) test sets do not count frame errors as bit errors when the test pattern is framed and the H4TU-C-319 is set to the Auto framing mode. To improve compatibility with those test sets, the H4TU-C generates 231 (NLOC and CREM) ID bit errors. As a result, the H4TU-C may indicate one more or one less bit error, depending on the test set type and the number of frame bits contained in the block of errored bits. To avoid this uncertainty, ADC recommends sending unframed IR commands.

The H4TU-C is now in logic loopback if the IOR NLOC loopback command was sent. The Time-Out Override command or a Loopdown command can override the selection made for the loopback time-out (see [“Setting the Loopback Time-Out Option \(LBTO\)” on page 48](#)). If the Time-Out Override code 1101-0101-1101-0110 (D5D6) is received after activating a loopback, then the automatic timed expiration of the loopback is inhibited. If this Time-Out Override is sent, then the only way to loop the H4TU-C down is to do one of the following:

- Issue the IR (Intelligent Repeater) LPDN (loopdown) code 1001-0011-1001-0011 (9393).
- Issue the NI LPDN and Disarm inband code 11100 or the ESF-DL code (FF24).



The Time-Out Override function is only valid for the current active loopback. The automatic time-out timer is restored during subsequent loopback sessions.

- 5 Once the test is complete, do one of the following:
- If the system is to loopdown but remain armed, send the IR (Intelligent Repeater) LPDN code (universal loopdown).
 - If all the equipment is to be looped down, disarmed and returned to normal operation, send the disarm inband code 11100 or the ESF-DL code (FF24).



The Armed mode has an automatic time-out of 120 minutes, but this timer is reset to 120 for any of the following events:

- **Loopback terminates (manually or time-out)**
- **Query**
- **Alternate query**
- **Far End activate**
- **Another ARM command**

This timer is inhibited while any of the valid command codes are being sent. Once the codes are removed, the timer restarts at 120.

TESTING WITH H4TU-C BERT GENERATOR

The H4TU-C BERT Generator screen allows transmission of an unframed test signal from the H4TU-C toward either the CI or the network.



It is not recommended using the Bit Error Rate Tester from the remote and line unit at the same time.

- 1 Press **C** to select the Config menu (Figure 30).
- 2 Use the **↑** and **↓** arrow keys to select **BERT Generator**, then press **ENTER**.
- 3 Use the arrow keys to select an option and press the **SPACEBAR** to cycle through the settings. Refer to Table 19 for a list of BERT generator option settings.
- 4 Press **ENTER** to activate your choice.
- 5 To view BERT status, press **ESC** twice, then use the **←** arrow key to select the **Monitor** menu.
- 6 Press **ENTER**. You can exit the status screen while signal generation is active.

```

Monitor Performance Event Log Config Inventory Report Rlogon Help
+-----+
| Standard Options -> |
| ADC Options -> |
| BERT Generator -> |
+-----+
| BERT Signal Generator : ENA |
| BERT Signal Pattern : 1 in 8 |
| BERT Signal Linecode : AMI |
| BERT Signal Direction : NET only |
| BERT Interval : Continuous |
+-----+
Use <Spacebar> to cycle through option settings and <Enter> to activate
ID: xxxx--xxxx--xxxx--xxxx 02/01/2002 12:30:01 H4TU-C System: OK

```

Figure 30. H4TU-C BERT Generator Screen

Table 19. BERT Signal Generator Option Settings

Option	Description
BERT Signal Generator	Enabled (ENA) or Disabled (DIS)
BERT Signal Pattern	1-in-8 pattern, 2-in-8 pattern, 3-in-24 pattern, 2^{23-1} pseudo random, 2^{20-1} pseudo random, 2^{15-1} pseudo random
BERT Signal Linecode	AMI or B8ZS
BERT Signal Direction	Toward CPE or toward NET
BERT Interval	5 minutes, 60 minutes, Continuous (default)

TESTING WITH H4TU-R BERT GENERATOR

The H4TU-R BERT Generator screen allows transmission of an unframed test signal from the H4TU-R towards either the network (NET) or customer (CPE). Bit error rates are calculated and display on the Monitor screen.

- 1 Press **R** to logon remotely, then press **C** to select the Config menu (Figure 31).
- 2 Use the **↑** and **↓** arrow keys to select **BERT Generator**, then press **ENTER**.
- 3 Use the arrow keys to select an option, then press the **SPACEBAR** to cycle through the settings. Refer to Table 19 on page 56 for a list of BERT Generator option settings.
- 4 Press **ENTER** to activate your choice.
- 5 To view BERT status, press **ESC** twice, then, using the **←** arrow key to select the **Monitor** menu, press **ENTER**.
- 6 Press **R** to return to the H4TU-C logon screen. You can exit the status screen while signal generation is active.

```

Monitor  Performance  Event Log  Config  Inventory  Report  Rlogon  Help
+-----+
| Standard Options -> |
| ADC Options      -> |
| BERT Generator  -> |
+-----+
| BERT Signal Generator : ENA |
| BERT Signal Pattern   : 1 in 8 |
| BERT Signal Linecode  : AMI |
| BERT Signal Direction : NET only |
| BERT Interval        : Continuous |
+-----+
Use <Spacebar> to cycle through option settings and <Enter> to activate
ID: xxxx--xxxx--xxxx--xxxx 02/01/2002 12:30:01 H4TU-R System: OK

```

Figure 31. H4TU-R BERT Generator Screen



The test pattern is sent out either from the line unit towards the network (toward NET) or from the remote unit towards the customer (toward CPE). Both test payloads must be looped back so they can be returned to the unit for BER detection. BER detection is performed in the line unit for both switch settings.

Tests done towards the NET must be looped at some point external to the higher circuit. Tests done towards the CPE can either be looped back at some external point beyond the remote unit, or they can be looped back internally by a higher loopback, such as NREM. The test payload, for the CPE direction, also passes back and forth over the HDSL4 link to the H4TU-C before it is analyzed for errors.

APPENDIX A - SPECIFICATIONS

Power

Line Voltage	0, -185 Vdc, ± 123 Vdc (Voltage is applied across Loop 1 and Loop 2.)
CO Supply	-48 Vdc nominal (-42.5 Vdc to -56.5 Vdc) See "Power Consumption" and "Maximum Power Dissipation" and "Maximum Current Drain" on page 61.
Electrical Protection	Secondary surge and power cross-protection on HDSL4 ports. Requires external primary protection.
Fusing	Internal; connected to fuse alarm output on pin 10

Environmental

Operating Temperature	-40°F to +149°F (-40°C to +65°C)
Operating Humidity	5% to 95% (non-condensing)

Physical

Height	4.750 in. (12.10 cm)
Width	0.625 in. (1.59 cm)
Depth	10 in. (25.4 cm)
Weight	0.5 lb. (0.23 kg)
Mounting	3192 high-density mechanics shelf

HDSL4

Line Code	784 kbps Overlapped Pulse Amplitude Modulation (OPAM) transmission per pair per HDSL4 standard in ANSI T1.418 Issue 2
Transmission	Full duplex
CSA Reach	34 kft. maximum using 26 AWG wire: 12kft. (span 1), 11 kft. (span 2), 11 kft. (span 3)
Media	One non-loaded, copper, four-wire cable pair
Output	+14.1 dBm ± 0.5 dBm at 135 Ω
Line Impedance	135 Ω
Maximum Insertion Loss	Span 1 = 47 dB at 196 kHz Span 2 and Span 3 = 43 dB at 196 kHz
Maximum Loop Attenuation	Span 1 = 31 dB Span 2 and Span 3 = 29 dB
Start-Up Time	30 sec. (typical), 1 min. (maximum)

DSX-1

Line Impedance	100 Ω
Line Rate	1.544 Mbps ± 200 bps
Line Format	Alternate Mark Inversion (AMI) or Bipolar with 8-Zero Substitution (B8ZS)
Frame Format	Extended SuperFrame (ESF), SuperFrame (SF), or Unframed (UNFR)
Pulse Output	6 V ^{pk-pk} pre-equalized for 0 to 655 feet of ABAM cable
Input Level	+1.5 to -7.5 dB DSX

System

One-way DS1 Delay	<700 μ s
Wander (Looped)	Meets MTIE T1.101 requirements
Wideband Jitter (Looped)	0.2 UI maximum
Narrowband Jitter (Looped)	0.1 UI maximum

POWER CONSUMPTION

The three most important power parameters of an H4TU-C are its maximum power consumption, maximum power dissipation, and maximum current drain.

Table 20 describes line-powered and locally powered (remote) circuits on the maximum reach condition (34 kft.) using 26 AWG wire.

Table 20. H4TU-C Power Parameters

Number of Doublers	Remote Power Source	-48 Vdc Power Consumption (Watts)		Heat Dissipation (Watts)		-42.5 Vdc Current (mA)	
		Typical	Maximum	Typical	Maximum	Typical	Maximum
None	Locally powered	7.6	8.4	5.9	6.4	179	197
None	Line-powered	11.0	12.1	6.2	6.8	259	285
1	Locally powered	14.6	16.1	6.6	7.2	344	378
1	Line-powered	20.0	22.0	7.1	7.8	471	518
2	Locally powered	26.7	29.4	8.4	9.2	628	691
2	Line-powered	32.9	36.2	9.3	10.3	774	852

MAXIMUM POWER DISSIPATION

The maximum power dissipation measures the power converted into heat which builds up within the unit. It contributes to the total heat generated in the space around the unit. It is used to determine the maximum number of fully loaded shelves per bay that does not exceed the maximum allowable power dissipation density in watts per square foot to comply with GR-63.

In COs, the maximum power dissipation for open-faced, natural convection-cooled mountings is limited to 134.7 watts per square foot per GR-63-CORE. Use this limit and the parameters in Table 21 on page 61 to determine the maximum number of H4TU-C circuits that can occupy one CO bay.



This is a worst case situation since it assumes the entire CO is subjected to the maximum power density. More favorable conditions would permit increasing the number of shelves per bay without jeopardizing the CO thermal integrity.

The thermal loading limitations imposed when using the H4TU-C in a Controlled Environmental Vault (CEV) or other enclosures are determined by applying its power parameters to the manufacturer's requirements for each specific housing.

The -48 Vdc power consumption is the maximum total power that the H4TU-C consumes or draws from the shelf power source. This parameter is needed when the H4TU-C is in a location remote to the CO it is serving. It determines the battery capacity required to maintain an 8-hour, standby battery reserve for emergency situations. Battery capacity, therefore, limits the maximum number of line units which can be installed in a remote enclosure. Use the data in Table 21 to perform this analysis.

MAXIMUM CURRENT DRAIN

The maximum current drain is the maximum current drawn from the shelf power supply when it is at its minimum voltage (-42.5 Vdc). This determines the shelf fusing requirements. Use the -42.5 Vdc current data in [Table 21](#) to determine the shelf fusing requirements for your particular H4TU-C applications.

LOOP ATTENUATION, INSERTION LOSS, AND REACH

For Span 1, each loop has no more than 47 dB of insertion loss at 196 kHz, with driving and terminating impedances of 135Ω, as shown in [Table 21](#) below. This is equivalent to no more than 34 dB loop attenuation.

For Span 2 and Span 3, each loop has no more than 43 dB of insertion loss at 196 kHz, with driving and terminating impedances of 135Ω. This is equivalent to no more than 31 dB loop attenuation.

Table 21. HDSL4 Reach Chart

Cable Gauge	Insertion Loss ^(a) at 196 kHz (dB/kft)	Loop Attenuation (dB/kft)	Maximum Reach (kft) Span 1	Maximum Reach (kft) Span 2 and Span 3	Ω per kft
26/0.4 mm	3.88	2.8	12	11.0	83
24/0.51 mm	2.84	2.0	16	15.0	52
22/0.61 mm	2.18	1.6	21	20.6	32
19/0.91 mm	1.54	1.1	29	27.8	16

(a) Insertion Loss = 1.38 times loop attenuation

H4TU-C-319 CARD-EDGE CONNECTOR

Figure 32 shows the card-edge connectors on the H4TU-C-319. Active pins are highlighted in black.

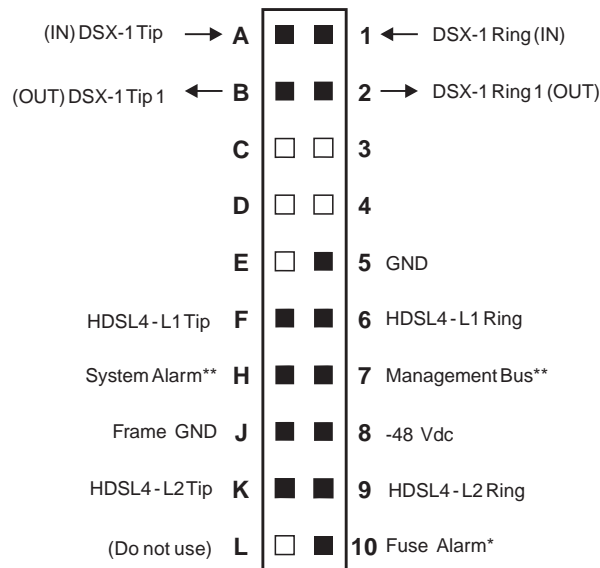

* Fuse Alarm
 Normal = Floating (0 to -60 Vdc maximum)
 Activated = -48 Vdc (10 mA maximum)

** System Alarm and Management Bus (reserved)

Figure 32. H4TU-C-319 Card-Edge Connector

Network Management Control Bus

The H4TU-C provides a Network Management Control Bus on pin 7 of the card-edge connector. This allows the various Management System protocols to manage the H4TU-C through the H4TU-319. Whenever the H4TU-C is under management, the MNGD message displays periodically on the front-panel display.



Some H4TU-C-319 features are affected when it is under management. Consult the management unit practice for further information (see “Appendix D - Product Support” on page 66).

Fuse Alarm

Pin 10 on the card-edge connector is a Fuse Alarm that is driven to -48 Vdc whenever its onboard fuse opens. It emulates the function of the Fuse Alarm output from pin 10 on normal, high-density (HD) repeaters. Pin 10 is connected to pin 5 of the 1184 Alarm Card (slot 1 in the HD shelf) and causes the 1184 Fuse ALM LED to light when the pin 10 signal is activated. Its normally floating output must never be driven above ground or below -80 V. It can sink a current of 10 mA. The H4TU-C does not support the BPV function (Pin E) of normal HD repeaters.

System Alarm Output Pin

Pin H on the card-edge connector (see [Figure 33 on page 63](#)) is the H4TU-C-319 System Alarm output pin. The following notes apply to Pin H:

- Pin H replaces the Local Loss of Signal (LLOS) on normal high-density (3192) repeaters.
- The normally floating output of Pin H can connect to pin 1 of the 1184 or 3192-9F Alarm Card in position 29 of the High Density (HD) shelf.
- The H4TU-C forces pin H to +5Vdc (maximum of 10 mA) for a system alarm condition. Pin H then remains at +5 Vdc for the duration of the alarm condition.
- If the Wescom 1184 Alarm Card is installed in the shelf, its LOS LED lights for every minor alarm (MNRALM).
- The H4TU-C Status LED flashes red for the duration of a system alarm condition.
- Setting the ALM option to DIS only prevents the system alarm bus on Pin H from being activated for a system alarm event. The Status LED still flashes red and the ALRM message still displays.



Pin H must never be taken above +5 Vdc or below -60 Vdc.

CRAFT PORT

[Figure 33](#) shows the pinout for the craft port connection and its connection to a DB-9 or DB-25 connector on a maintenance terminal.

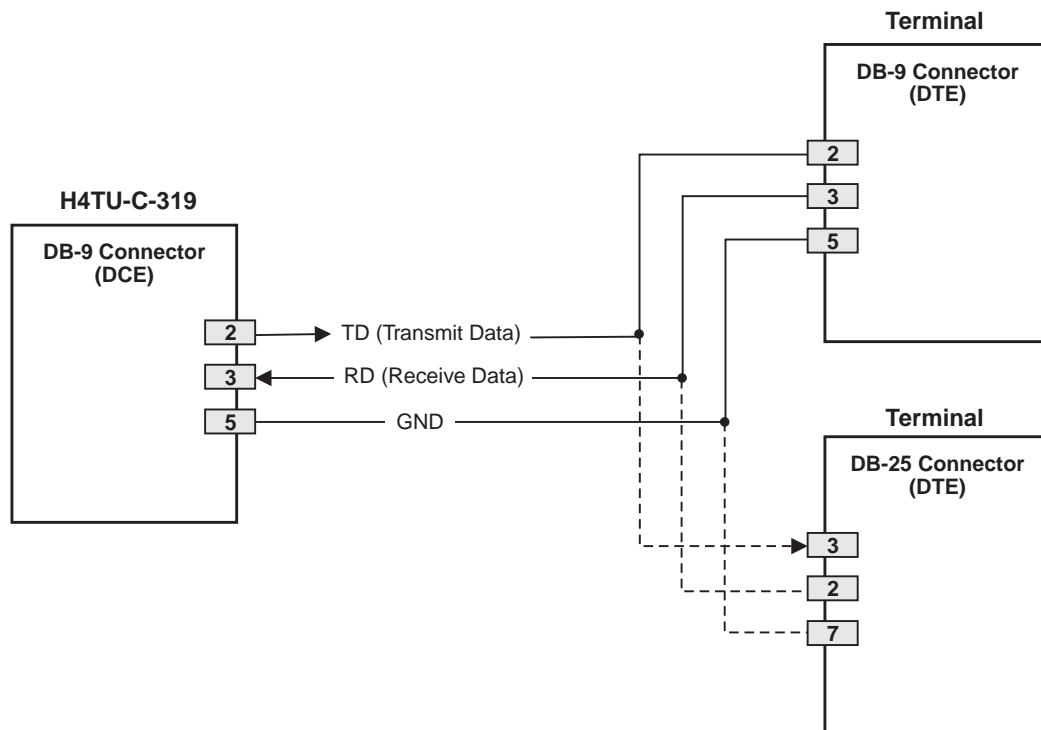

Figure 33. RS-232 Craft Port Pinouts

APPENDIX B - FUNCTIONAL OPERATION

HDSL4 technology provides full-duplex services at standard T1 rates over two pairs of copper wire between an H4TU-C, H4Ds (if necessary), and an H4TU-R which comprise one ADC system. ADC systems use Overlapped Pulse Amplitude Modulation Transmission (OPAM) transceiver systems to establish two, full-duplex, 784 kbps data channels between the H4TU-C-319 and a remotely located H4TU-R.

A block diagram of the H4TU-C-319 is shown in Figure 34. The H4TU-C-319 receives a 1.544 Mbps DSX-1 data stream from the DSX-1 digital cross-connect interface. The H4TU-C-319 contains a DS1 frame synchronizer controlled by an 8-bit microprocessor that determines the type of framing on the DS1 stream and synchronizes with it. The H4TU-C-319 recognizes Superframe (SF), including D4, or Extended Superframe (ESF) framing. When the data is unframed, the H4TU-C-319 arbitrarily defines a frame bit.

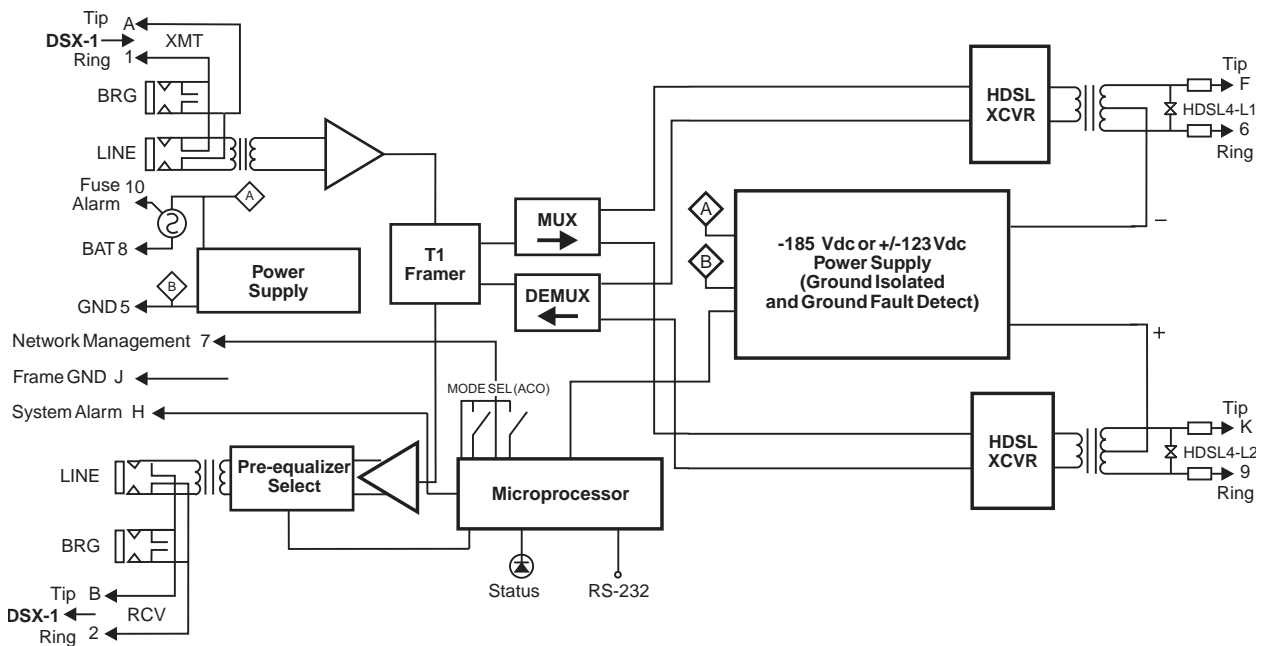

Figure 34. H4TU-C-319 List 1 Block Diagram

TIMING

The low-loop wander (0.5 UI max) of an H4TU-C, when used with remote units, allows the circuit to be used in all critical timing applications, including those used to transport Stratum 1 timing.

GROUND FAULT DETECTION

The H4TU-C has a Ground Fault Detection (GFD) circuit which detects a ground or a resistive path to ground on any wire of the HDSL4 loop. This makes the product compliant with the Class A2 requirements of GR-1089.

SPECTRUM ISSUES

The asymmetric 776 kbps spectrum, defined in ANSI T1.418 Issue 2, allows the HDSL4 product to be spectrally compatible with ADSL services in adjacent pairs in the same binding groups for all non-doubler applications. A combination of asymmetric and symmetric spectrums is used for ADSL compatibility in doubler applications.

APPENDIX C - COMPATIBILITY

The HDSL4 system uses HDSL4 transmission technology as recommended by ANSI committee in compliance with the August 1999 T1-E1.4/99-006R5 HDSL4 standards.

The H4TU-C List 1 is designed to mount in the following shelves with 3192 mechanics:

- HMS-317 (28-slot, 23-inch shelf)
- HMS-318 (22-slot, 19-inch shelf)
- HMS-357 (28-slot, 23-inch shelf)
- HMS-358 (28-slot, 23-inch shelf)
- HHS-319 (3-slot, 19-inch horizontal shelf)
- HCS-402 (2-slot) with a 150-1192-01 adaptor
- HMS-308 (8-slot remote enclosure)
- Charles Ind. #3192 (28-slot connectorized)
- Charles Ind. #3192-WR (28-slot wire wrap)
- Charles Ind. #343-00 (12- to 14-slot wire wrap)
- Charles Ind. #319-02 (22-slot connectorized)
- Charles Ind. #319-04 (22-slot wire wrap)
- Charles Ind. #340-00 (9-slot to 11-slot wire wrap)
- Larus #1185 (28-slot connectorized)



Charles Ind. 343-00 and 340-00 shelves do not support the H4TU-C-319 System Alarm output on pin H. Also, if slots 1 and 2 of these shelves were wired for the 3408 Fault Locate unit, they must be rewired to accept the H4TU-C-319.

APPENDIX D - PRODUCT SUPPORT

ADC Customer Service Group provides expert pre-sales and post-sales support and training for all its products. Technical support is available 24 hours a day, 7 days a week by contacting the ADC Technical Assistance Center.

Sales Assistance 800.366.3891	<ul style="list-style-type: none"> • Quotation Proposals • Ordering and Delivery • General Product Information
Systems Integration 800.366.3891	<ul style="list-style-type: none"> • Complete Solutions (from concept to installation) • Network Design and Integration Testing • System Turn-Up and Testing • Network Monitoring (upstream or downstream) • Power Monitoring and Remote Surveillance • Service/Maintenance Agreements • Systems Operation
ADC Technical Assistance Center 800.638.0031 Email: wsd_support@adc.com	<ul style="list-style-type: none"> • Technical Information • System/Network Configuration • Product Specification and Application • Training (product-specific) • Installation and Operation Assistance • Troubleshooting and Repair/Field Assistance
Online Technical Support	<ul style="list-style-type: none"> • www.adc.com/Knowledge_Base/index.jsp
Online Technical Publications	<ul style="list-style-type: none"> • www.adc.com/documentationlibrary/technicalpublications/
Product Return Department 800.366.3891 Email: rma@adc.com	<ul style="list-style-type: none"> • ADC Return Material Authorization (RMA) number and instructions must be obtained before returning products.

All telephone numbers with an 800 prefix are toll-free in the USA and Canada.

APPENDIX E - ABBREVIATIONS

A

ACO:	Alarm Cutoff
ADSL:	Asymmetryic Digital Subscriber Line
AIS:	Alarm Indication Signal
ALM:	Alarm
ALMP:	Alarm Pattern
AMI:	Alternate Mark Inversion
AOR:	Addressable Office Repeater
ARM:	Armed
ASCII:	American Standard Code for Information Interchange
AWG:	American Wire Gauge

B

B8ZS:	Bipolar with 8-Zero Substitution
BER:	Bit Error Rate
BERT:	Bit Error Rate Tester
BPV:	Bipolar Violation
BPVT:	Bipolar Violation Transparency
BRG:	Bridge

C

CEV:	Controlled Environmental Vault
CI:	Customer Installation
CLEI:	Common Language Equipment Identifier
CLOC:	Customer Local Loopback
CO:	Central Office
COLB:	Central Office Loopback
CPE:	Customer Premises Equipment
CRC:	Cyclical Redundancy Check
CREM:	Customer Remote Loopback
CSA:	Carrier Service Area
CV:	Code Violation
CV-L:	Code Violation - Line
CV-P:	Code Violation - Path

D

DBER:	DS1 Bit Error Rate
DDS:	Digital Data Service
DL:	Data Link
DLC:	Digital Loop Carrier
DS1:	Digital Signal, Level 1
DSX-1:	Digital Signal Cross-Connect, Level 1

E

ECI:	Equipment Catalog Item
EQL:	Equalization
ESD:	Electrostatic Discharge
ESF:	Extended SuperFrame
ES-L:	Errored Seconds - Line
ES-P:	Errored Seconds - Path

F

FE:	Far End
FRMG:	Framing

H

H4TU-C:	HDSL4 Line Unit
H4TU-R:	HDSL4 Remote Unit
HBER:	HDSL4 Block Error Rate
HCDS:	High Capacity Digital Service
HDSL:	High-bit-rate Digital Subscriber Line
HG:	HDSL Generic
HMU:	HiGain Management Unit

I

ID:	Identification
ILR:	Intelligent Repeater Loop
IN:	Transmit
INSL:	Insertion Loss
IOR:	Intelligent Office Repeater

L

LA: Loop Attenuation
LAIS: Line Alarm Indication Signal
LATT: Loop Attenuation
LBPV: Local Bipolar Violation
LBTO: Loopback Timeout
LED: Light Emitting Diode
LLOS: Line (Unit) Loss of Signal
LOF: Loss of Frame
LOSW: Loss of Sync Word
LPDN: Loopdown
LPF: Line Power Feed
LRAI: Line (Clear) Remote Alarm Indication

M

M: HDSL4 Margin
MAL: Margin Alarm
MARG: Margin
MNGD: Managed
MSEC: Monitored Seconds

N

NE: Near End
NI: Network Interface
NID: Network Interface Device
NLBP: Network Loopback Pattern
NLOC: Network Local Loopback
NMA: Network Management and Administration
NREM: Network Remote Loopback

O

OPAM: Overlapped Pulse Amplitude Modulation
OUT: Receive

P

PBOC: Power Back Off - Customer
PBON: Power Back Off - Network
PL: Payload
POTS: Plain Old Telephone Service

PRM: Performance Report Messaging
PRM-FE: Performance Report Messaging - Far End
PRM-NE: Performance Report Messaging - Near End
PWRF: Power Feed

R

RAI: Remote Alarm Indication
RAI-CI: Remote Alarm Indication - Customer Installation
RAIS: Remote Alarm Indication Signal
RDA: Remote Disconnect Alarm
RLOS: Remote (Unit) Loss of Signal
RRAI: Remote RAI
RTPV: Remote Provisioning
RULB: Remote Unit Loopback

S

S/N: Signal-to-Noise Ratio
SDSL: Symmetrical Digital Subscriber Line
SES: Severely Errored Seconds
SES-L: Severely Errored Seconds - Line
SES-P: Severely Errored Seconds - Path
SF: SuperFrame
SMJK: SmartJack

T

TLOS: Transmit Loss of Signal

U

UAS : Unavailable Seconds
UAS-L: Unavailable Seconds - Line
UAS-P: Unavailable Seconds - Path
UNFR: Unframed

CERTIFICATION AND WARRANTY

FCC CLASS A COMPLIANCE

This equipment has been tested and found to comply with the limits for a Class A digital device, pursuant to Part 15 of the FCC Rules. These limits are designed to provide reasonable protection against harmful interference when the equipment is operated in a commercial environment. This equipment generates, uses, and can radiate radio frequency energy and, if not installed and used in accordance with the instruction manual, may cause harmful interference to radio communications. Operation of this equipment in a residential area is likely to cause harmful interference in which case the user will be required to correct the interference at his own expense.

LIMITED WARRANTY

ADC DSL Systems, Incorporated (“ADC”) warrants that, for a period of sixty (60) months from the date of shipment, the hardware portion of its products will be free of material defects and faulty workmanship under normal use. ADC’s obligation, under this warranty, is limited to replacing or repairing, at ADC’s option, any such hardware product which is returned during the 60-month warranty period per ADC’s instructions and which product is confirmed by ADC not to comply with the foregoing warranty.

ADC warrants that, for a period of 90 days from the date of purchase, the software furnished with its products will operate substantially in accordance with the ADC published specifications and documentation for such software. ADC’s entire liability for software that does not comply with the foregoing warranty and is reported to ADC during the 90-day warranty period is, at ADC’s option, either (a) return of the price paid or (b) repair or replace of the software. ADC also warrants that, for a period of thirty (30) days from the date of purchase, the media on which software is stored will be free from material defects under normal use. ADC will replace defective media at no charge if it is returned to ADC during the 30-day warranty period along with proof of the date of shipment.

The transportation charges for shipment of returned products to ADC will be prepaid by the Buyer. ADC will pay transportation charges for shipment of replacement products to Buyer, unless no trouble is found (NTF), in which case the Buyer will pay transportation charges.

ADC may use reconditioned parts for such repair or replacement. This warranty *does not* apply to any product which has been repaired, worked upon, or altered by persons not authorized by ADC or in ADC’s sole judgment has been subjected to misuse, accident, fire or other casualty, or operation beyond its design range.

Repaired products have a 90-day warranty, or until the end of the original warranty period—whichever period is greater.

ADC DISCLAIMS ALL OTHER WARRANTIES, EITHER EXPRESS OR IMPLIED, INCLUDING BUT NOT LIMITED TO IMPLIED WARRANTIES OF MERCHANTABILITY AND FITNESS FOR A PARTICULAR PURPOSE, WITH RESPECT TO ITS PRODUCTS AND ANY ACCOMPANYING WRITTEN MATERIALS. FURTHER, ADC DOES NOT WARRANT THAT SOFTWARE WILL BE FREE FROM BUGS OR THAT ITS USE WILL BE UNINTERRUPTED OR REGARDING THE USE, OR THE RESULTS OF THE USE, OF THE SOFTWARE IN TERMS OF CORRECTNESS, ACCURACY, RELIABILITY OR OTHERWISE.

MODIFICATIONS

Any changes or modifications made to this device that are not expressly approved by ADC DSL Systems, Inc. voids the user’s warranty. All wiring external to the products should follow the provisions of the current edition of the National Electrical Code.

SAFETY STANDARDS COMPLIANCE

The H4TU-C-319 List 1 has been tested and verified to comply with the applicable sections of the following safety standards:

- GR 63-CORE - Network Equipment-Building System (NEBS) Requirements
- GR 1089-CORE - Electromagnetic Compatibility and Electrical Safety
- Binational standard, UL-60950/CSA-C22.2 No. 60950-00: Safety of Information Technology Equipment

For technical assistance, refer to [“Appendix D - Product Support”](#) on page 66.

World Headquarters

ADC Telecommunications, Inc.
PO Box 1101
Minneapolis, Minnesota USA 55440-1101

For Technical Assistance

Tel: 800.366.3891



DOCUMENT: LTPH-UM-1031-03, ISSUE 3



1274229



Free Manuals Download Website

<http://myh66.com>

<http://usermanuals.us>

<http://www.somanuals.com>

<http://www.4manuals.cc>

<http://www.manual-lib.com>

<http://www.404manual.com>

<http://www.luxmanual.com>

<http://aubethermostatmanual.com>

Golf course search by state

<http://golfingnear.com>

Email search by domain

<http://emailbydomain.com>

Auto manuals search

<http://auto.somanuals.com>

TV manuals search

<http://tv.somanuals.com>