



# **Cellworx<sup>®</sup> STN**

## **Release 3.1 GUI Users Manual**

---





# Release 3.1 GUI Users Manual

---

## COPYRIGHT

© 2000, ADC Telecommunications, Inc.  
All Rights Reserved  
Printed in the U.S.A.

## REVISION HISTORY

ISSUE	DATE	REASON FOR CHANGE
Issue 1	02/2001	Phase 3.1 release features added, (622 CRS)

## TRADEMARK INFORMATION

ADC and ADC Telecommunications are registered trademarks of ADC Telecommunications, Inc.

Cellworx is a trademark of ADC Telecommunications, Inc.

## DISCLAIMER OF LIABILITY

Contents herein are current as of the date of publication. ADC reserves the right to change the contents without prior notice. **In no event shall ADC be liable for any damages resulting from loss of data, loss of use, or loss of profits and ADC further disclaims any and all liability for indirect, incidental, special, consequential or other similar damages. This disclaimer of liability applies to all products, publications and services during and after the warranty period.**

This publication may be verified at any time by contacting ADC's Technical Assistance Center at 1-800-366-3891, extension 54878 (in U.S.A. or Canada) or 1-972-680-4878 (outside U.S.A. and Canada), or by writing to ADC Telecommunications, Inc., Attn: Technical Assistance Center, Mail Station #77, P.O. Box 1101, Minneapolis, MN 55440-1101, U.S.A.



ADC Telecommunications, Inc.  
P.O. Box 1101, Minneapolis, Minnesota 55440-1101  
In U.S.A. and Canada: 1-800-366-3891  
Outside U.S.A. and Canada: (952) 938-8080  
Fax: (952) 946-3292

## TABLE OF CONTENTS

Content	Page
<b>PREFACE</b>	
ABOUT THIS MANUAL .....	VII
REVISION HISTORY LIST .....	VII
LIST OF CHANGES .....	VII
TRADEMARK INFORMATION .....	VII
RELATED PUBLICATIONS .....	VII
ADMONISHMENTS .....	VII
GENERAL SAFETY PRECAUTIONS .....	VIII
FCC COMPLIANCE STATEMENT .....	IX
DOC COMPLIANCE .....	IX
FDA COMPLIANCE .....	IX
SAFETY COMPLIANCE .....	IX
NEBS COMPLIANCE .....	IX
ISO 9000 COMPLIANCE .....	IX
REFERENCES .....	X
LIST OF ACRONYMS AND ABBREVIATIONS .....	XII

## SECTION 1 INTRODUCTION

Content	Page
1. GENERAL .....	1-1
2. USER INTERFACES .....	1-2
A. NMIC RS232 Interface .....	1-3
B. NMIC EIM RJ45 Ethernet Interface .....	1-3
C. NMIC Serial Equipment Port .....	1-4
3. CELLWORX STN SYSTEM SOFTWARE .....	1-4
A. NMIC Graphical User Interface (GUI) .....	1-4
GUI Screen Icon Definitions .....	1-5
GUI Menu Structure and Utilization .....	1-8
X-Terminal Keyboard Functions .....	1-11
Manipulating the GUI Network Layout on an X-Terminal Screen .....	1-12
4. REMOTE MANAGEMENT CAPABILITIES .....	1-12
A. Real Time Alarm and trap Screens .....	1-13

## SECTION 2 OPERATION AND MAINTENANCE

Content	Page
1. GENERAL.....	2-1
2. USING A TOP DOCUMENT.....	2-1
ALPHABETICAL TASK INDEX LIST .....	2-3
INDEXED TASK LIST .....	IXL-001
TURN UP A NEW CELLWORX STN RING NETWORK .....	NTP-002
ADD A CELLWORX STN NODE TO AN IN SERVICE RING NETWORK.....	NTP-003
ADD A SECOND NETWORK ELEMENT TO AN IN SERVICE STAND-ALONE TERMINAL TO CREATE A RING NETWORK .....	NTP-004
TURN UP (PROVISION) CELLWORX STN EXPANSION SHELVES.....	NTP-005
PROVISION NODE PARAMETERS .....	NTP-006
DISPLAYING STATUS AND ALARMS.....	NTP-007
RETRIEVE PERFORMANCE MONITORING STATISTICS .....	NTP-008
ADDING SERVICES TO A CELLWORX STN NODE.....	NTP-009
DELETE A CELLWORX STN NODE .....	NTP-010
CONDUCT ACCEPTANCE TESTS ON CELLWORX STN NODE .....	NTP-011
PERFORM ROUTINE AND NON-ROUTINE MAINTENANCE.....	NTP-012
PROVISION ATM VP AND VC CONNECTIONS.....	NTP-013
MONITORING THE NETWORK.....	NTP-014
ADMINISTRATIVE TASKS .....	NTP-015
CELLWORX UPGRADE PROCEDURES .....	NTP-016
POWER UP A CELLWORX STN NODE.....	DLP-700
CONNECT FIBERS TO OPTICAL CARDS .....	DLP-701
CONNECT VT100 TO NMIC RS-232 PORT AND MODIFY NMIC IP ADDRESS .....	DLP-702
LOGON TO REMOTE NODE CRAFT SESSION VIA TELNET FROM GUI .....	DLP-703
CONNECT NMS OR X-TERMINAL TO THE NMIC EIM SNMP/GUI PORT .....	DLP-704
LAUNCH THE GRAPHICAL USER INTERFACE (GUI) .....	DLP-705
PERFORM DISCOVERY ON A NEW CELLWORX STN RING NETWORK .....	DLP-706
TIME AND DATE .....	DLP-707
CREATE A N ATM OR CES CONNECTION .....	DLP-708
CONFIGURE OR DELETE A TRAFFIC CONTRACT.....	DLP-709
VIEW CONNECTIONS .....	DLP-710
LOG OFF OF CELLWORX STN GRAPHICAL USER INTERFACE.....	DLP-711
ADD EXPANSION NODES (STN-EPS).....	DLP-712
DISPLAY NETWORK ALARM SUMMARY .....	DLP-713
CONFIGURE SERVICE PROVIDER PROFILE.....	DLP-714
VIEW RING RESOURCE USAGE .....	DLP-715
VIEW FIBER BANDWIDTH USAGE .....	DLP-716
CONFIGURE NE ALARM THRESHOLD .....	DLP-717
REFRESH TOPOLOGY .....	DLP-718
FORCE NETWORK DISCOVERY .....	DLP-719
SOFTWARE SELECTION.....	DLP-720

(continued)

## SECTION 2 OPERATION AND MAINTENANCE, CONTINUED

Find Your Job in the List Below	Then Go To
ABOUT NE .....	DLP-721
NMIC SYSTEM FILE REPLICATION .....	DLP-722
CHANGE CONFIGURATION/TEST ON AN EXISTING CONNECTION .....	DLP-723
NMIC PROTECTION .....	DLP-724
NMIC PROTECTION RESTORATION .....	DLP-725
SET / RETRIEVE OPTICAL PORT PERFORMANCE MONITORING STATISTICS .....	DLP-726
SET / RETRIEVE T3 TMUX PERFORMANCE MONITORING STATISTICS .....	DLP-727
SET / RETRIEVE T3 CRS PORT PERFORMANCE MONITORING STATISTICS .....	DLP-728
SET / RETRIEVE T1/E1 MULTI 1 CRS PERFORMANCE MONITORING STATISTICS .....	DLP-729
RETRIEVE NETWORK DATA COLLECTION (NDC) STATISTICS .....	DLP-730
RING UPGRADE PROCEDURE .....	DLP-731
SET / RETRIEVE FT1 FRS PERFORMANCE MONITORING STATISTICS .....	DLP-732
SET / RETRIEVE FE1 FRS PERFORMANCE MONITORING STATISTICS .....	DLP-733
SOFTWARE FALLBACK .....	DLP-734
HELP .....	DLP-735
REVERT TO SAVED ICON LAYOUT .....	DLP-736
ADD A RING NETWORK ELEMENT .....	DLP-737
ADD A SECOND NETWORK ELEMENT .....	DLP-738
DELETE CONNECTIONS .....	DLP-739
DELETE A CELLWORX STN SHELF .....	DLP-740
RETRIEVE LOGS FROM THE NMIC VIA FTP .....	DLP-741
RETRIEVE COMPRESSED LOGS FROM THE NMIC VIA FTP .....	DLP-742
REFLASH BOOT IMAGE .....	DLP-744
SYSTEM DATABASE ACCESS .....	DLP-745
DELETE A CELLWORX STN EXPANSION SHELF (EPS) .....	DLP-746
SET E1 MULTI 1 CARD CONFIGURATION .....	DLP-747
SET SC CARD CONFIGURATION (IP ADDRESS, CRAFT INTERFACE) .....	DLP-748
SET SHELF TIMING RESOURCE .....	DLP-749
SET SHELF HOUSEKEEPING ALARM CONFIGURATION .....	DLP-750
SET 622 RING CARD CONFIGURATION .....	DLP-751
SET 155 SM/MM CRS CARD CONFIGURATION .....	DLP-752
SET T3 CRS CARD CONFIGURATION .....	DLP-753
SET T3 TMUX MULTI 1 AND TMUX EXP CONFIGURATION .....	DLP-754
SET T1 MULTI 1 CARD CONFIGURATION .....	DLP-755
SET 155 RING INTERFACE CARD CONFIGURATION .....	DLP-758
SET 2488 RING INTERFACE CARD CONFIGURATION .....	DLP-756
RETRIEVE SC CARD STATUS .....	DLP-757
RETRIEVE 622 RIC STATUS .....	DLP-759
RETRIEVE 155 CRS STATUS .....	DLP-760
RETRIEVE T3 CRS CARD STATUS .....	DLP-761
RETRIEVE T3 TMUX MULTI 1 CARD STATUS .....	DLP-762

## SECTION 2 OPERATION AND MAINTENANCE, CONTINUED

Find Your Job in the List Below	Then Go To
RETRIEVE 155 RING INTERFACE CARD STATUS .....	DLP-763
RETRIEVE T1 MULTI 1 CARD STATUS.....	DLP-764
CONFIGURE CARD PROTECTION GROUPS .....	DLP-765
PERFORM DIAGNOSTICS ON OPTICAL CARDS .....	DLP-766
SET SYSTEM IDENTIFIER .....	DLP-767
SET CRAFT USER CONFIGURATION .....	DLP-768
SET CRAFT MENU CONFIGURATION.....	DLP-769
HARDWARE INVENTORY .....	DLP-770
INITIATE A PROTECTION SWITCH.....	DLP-771
LOOPBACK TEST .....	DLP-772
CARD AND SHELF RESET.....	DLP-773
VIEWING AND EDITING THE NMIC IP ADDRESS.....	DLP-774
ADD OR EDIT AN SNMP TRAP HOST ON THE NMIC.....	DLP-775
ALARM CUT-OFF (ACO) .....	DLP-776
REMOVE AND/OR REPLACE CELLWORX CARDS .....	DLP-777
ENDING A GUI SESSION FOLLOWING AN ABNORMAL SESSION ENDING.....	DLP-778
RETRIEVE 2488 RING INTERFACE CARD STATUS.....	DLP-779
PHASE 2.0 TO 3.0 SOFTWARE UPGRADE PROCEDURE.....	DLP-780
REMOVING A NMIC CARD FROM THE SHELF .....	DLP-781
FTP DATABASE FILES OFF OF NMIC .....	DLP-782
ADD/DELETE GUI USERS OR CHANGE GUI USER LEVEL SECURITY .....	DLP-783
SET FE1 FRS CARD CONFIGURATION .....	DLP-784
SET FT1 FRS CARD CONFIGURATION .....	DLP-785
CREATE A FRAME RELAY CONNECTION .....	DLP-786
CREATE AN ATM MULTICAST CONNECTION .....	DLP-787
RETRIEVE FT1 FRS CARD STATUS .....	DLP-788
RETRIEVE FE1 FRS CARD STATUS .....	DLP-789
CREATING AN ATM BUNDLED VC MULTICAST CONNECTION.....	DLP-790
ADD A LEAF ENDPOINT TO AN IN-SERVICE CONNECTION.....	DLP-791
SET T3 CES CARD CONFIGURATION.....	DLP-792
RETRIEVE T3 CES CARD STATUS.....	DLP-793
SET / RETRIEVE T3 CES PORT PERFORMANCE MONITORING STATISTICS.....	DLP-794
PHASE 3.0 TO 3.1 SOFTWARE UPGRADE PROCEDURE.....	DLP-795
RETRIEVE 622 CRS STATUS .....	DLP-796
SET 622 SM CRS CARD CONFIGURATION .....	DLP-797
SOFTWARE FALLBACK FROM RELEASE 3.1 TO RELEASE 3.0 .....	DLP-798
TROUBLE ANALYSIS PROCEDURE .....	TAP-100



### SECTION 3 GENERAL INFORMATION

Content	Page
1. WARRANTY/SOFTWARE .....	3-1
2. REPAIR/EXCHANGE POLICY .....	3-1
3. REPAIR CHARGES .....	3-2
4. REPLACEMENT/SPARE PRODUCTS .....	3-2
5. RETURNED MATERIAL .....	3-2
6. SYSTEM INTEGRATION SERVICES .....	3-3
7. CUSTOMER SUPPORT SERVICES .....	3-3

## ABOUT THIS MANUAL

This manual provides the system administrator with information necessary to turn up and test the Cellworx Service Transport Node (STN), and/or services, as well as configure connections and monitor the network using the CellworxVision Graphical User interface (GUI). Information provided within this document deals primarily with the Phase 3.1 design features of the Cellworx STN system.

## Trademark Information

The following trademarks are documented in this manual:

ADC and ADC Telecommunications are registered trademarks of ADC Telecommunications Inc.

Cellworx is a registered trademark of ADC Telecommunications Inc.

Open View is a registered trademark of Hewlett-Packard.

SRTS – Synchronous Residual Time Stamp is a patent of Bell Communications Research, Nov 9, 1993

## Related Publications

Listed below are all of the related manuals and their publication numbers. Copies of these publications can be ordered by contacting the ADC Technical Assistance Center at 1-800-366-3891 extension 63434 (in U.S.A. or Canada) or 612-946-3434 (outside U.S.A. and Canada).

Title/Description	Part Number
<b>Application and Engineering Guide 3.1</b>	<b>1152699</b>
Contains an introduction to the ADC Cellworx STN system, hardware and software descriptions, applications, and engineering information required for system deployment.	
<b>Craft User's Manual 3.1</b>	<b>1152703</b>
Contains information required for provisioning, operation, and administration of the Cellworx STN system through the craft access. Information includes detecting and isolating alarms, and turn up of features over the entire network.	
<b>System Description Manual 3.1</b>	<b>1152712</b>
Combines information from the Users Manual, Installation Manual, and Applications Engineering Manual to provide introductory information and a general overview of the Cellworx STN system.	
<b>Cellworx CLEI Code Guide</b>	<b>1112344</b>
Lists all CLEI codes used to order Cellworx equipment.	

## Admonishments

Important safety admonishments are used throughout this manual to warn of possible hazards to persons or equipment. An admonishment identifies a possible hazard and then explains what may happen if the hazard is not avoided. The admonishments — in the form of Dangers, Warnings, and Cautions — must be followed at all times. These warnings are flagged by use of the triangular alert icon (seen below), and are listed in descending order of severity of injury or damage and likelihood of occurrence.

 **Danger:** *Danger is used to indicate the presence of a hazard that **will** cause severe personal injury, death, or substantial property damage if the hazard is not avoided.*

 **Warning:** *Warning is used to indicate the presence of a hazard that **can** cause severe personal injury, death, or substantial property damage if the hazard is not avoided.*

 **Caution:** *Caution is used to indicate the presence of a hazard that **will** or **can** cause minor personal injury or property damage if the hazard is not avoided.*

## General Safety Precautions

 **Danger:** *Do not look into the ends of optical fibers. Exposure to invisible LASER radiation may cause serious retinal damage or even blindness. Verify the optical source is disabled through the use of an optical power meter before handling optical fibers.*

 **Caution:** *Use caution when routing wires and cables. Avoid severe bending and routing over sharp edges. Use grommet material when possible to avoid wear on cable insulation.*

 **Caution:** *Allow sufficient fiber length to permit routing without severe bends. Fibers may be permanently damaged, or signal degradation may be experienced if fibers are bent or curved to a radius of less than 1.5 inches (3.81 cm).*

 **Caution:** *Modules can be damaged by electrostatic discharge. Before handling any modules connect your wrist to an equipment ground using an approved anti-static wrist strap. Ensure that all uninstalled modules are stored in anti-static packing material. When working with modules, always place the module on an electrically grounded approved anti-static mat.*

 **Caution:** *Using excessive force when seating cards and modules into the backplane may result in physical or severe electrical damage to the backplane pins or module connectors, and if power is applied, may result in serious electrical damage to both the modules or the backplane*

## FCC COMPLIANCE STATEMENT

### Class A

The Cellworx STN System complies with the requirements for class A digital device per Part 15 of the FCC Rules.



**Warning:** *This equipment has been tested and found to comply with the limits for a Class A digital device, pursuant to part 15 of the FCC Rules. These limits are designed to provide reasonable protection against harmful interference when the equipment is operated in a commercial environment. This equipment generates, uses, and can radiate radio frequency energy and, if not installed and used in accordance with the instruction manual, may cause harmful interference to radio communications. Operation of this equipment in a residential area is likely to cause harmful interference in which case the user will be required to correct the interference at his own expense.*

### DOC Compliance

*This equipment does not exceed Class A limits for radio emission for digital apparatus, set out in the radio interference regulation of the authorization methods of Industry Canada. Operation in a residential area may cause unacceptable interference to TV and radio reception requiring the owner or operator to take whatever steps are necessary to correct the interference.*

### FDA Compliance

*This product uses a Class 1 LASER according to FDA Rules. This product conforms to all applicable standards of 21 CFR 1040.*

### Safety Compliance

UL listed for use in the U.S. and Canada.

IEC 950 (1991) Second Edition with Amdts. No. 1 (1992), 2 (1993), 3 (1995), and 4 (1996)  
EN60950 (1992) with Amdts. No. 1 (1993), 2 (1993), 3 (1995), 4 (1997), and No.11 (1997); and  
with National Differences as specified in the CB Test Report 99RT07840-121698.

The Cellworx STN system complies with EN 55022:1995, IEC 801-2:1991, IEC 801-3:1984 and draft IEC 801-3-1990, and IEC 801-4:1988.

The Cellworx STN system complies to all the applicable EC directives of the European Union and is CE marked.

### NEBS Compliance

The Cellworx STN system is fully NEBS compliant.

## ISO9000 Compliance

ADC Telecommunications Inc. is ISO 9001 certified.

## STANDARDS

The following listing is a bibliography of applicable documents:

ANSI/IEEE Std 802.1D, 1993 Edition.

ANSI T1.403-1989, Carrier to Customer Installation: T1 Metallic Interface, February 22, 1989

ATM UNI specification 3.1, ATM Forum

Bellcore GR-253-CORE, Synchronous Optical Network (SONET) Transport Systems: Common Generic Criteria, Issue 2, 12/95

Bellcore GR-1110-CORE, Broadband Switching System Generic Requirements, Issue 1, 9/94, Revision 3, 4/96

Bellcore GR-1113-CORE, Asynchronous Transfer Mode (ATM) and ATM Adaptation Layer (AAL) Protocols, Bellcore.

Bellcore GR-1117-CORE, Generic Requirements for Exchange PVC CRS Customer Network Management Service, Bellcore.

Bellcore GR-1244-CORE, Clocks for the Synchronized Network: Common Generic Criteria, Bellcore.

Bellcore GR-1248-CORE, "Generic Requirements for Operations of ATM Network Elements (NEs)," Issue 3, 8/96

Bellcore GR-1400-CORE, SONET Dual-fed Unidirectional Path Switched Ring (UPSR) Equipment Generic Criteria, Bellcore.

Bellcore GR-20-CORE, Generic Requirements for Optical Fiber and Optical Fiber Cable, Bellcore.

Bellcore GR-253-CORE, SONET Transport Systems: Common Criteria, Bellcore.

Bellcore GR-2837-CORE, "ATM Virtual Path Functionality in SONET Rings—Generic Criteria," Issue 2, 12/95

Bellcore GR-2842-CORE, "ATM Service Access Multiplexer (SAM) Generic Requirements," Issue 1, 11/94

Bellcore GR-2848-CORE, Broadband Multi-service UNI Generic Requirements, Bellcore.

Bellcore GR-436-CORE, Digital Network Synchronization Plan, Bellcore.

Bellcore TR-TSY-000496, Issue 2, September 1989, Supplement 1, September 1991

The ATM Forum	ATM User-Network Interface (UNI), Specification, Version 3.1
	ITU I.350
	ITU I.371
	ITU I.610
	Bellcore TA-1230
	ITU M.3010
	ITU M.3020
	ITU M.3100
	ITU M.3180
NFOEC,	Volume 2 1995, pg 445. "A Comparative Analysis of 2 Fiber and 4 Fiber Bi Directional Line Switched Rings."
NFOEC,	Volume 3 1995, pg 885. "SONET Operations Networking; The Key to the Future."
RFC-1406,	Definitions for Managed Objects for the T1 and E1 Interface Types, IETF.
RFC-1407,	Definitions for Managed Objects for the T3 and E3 Interface Types, IETF.
TA-NWT-000487,	Generic Requirements for Electronic Equipment Cabinets, Bellcore.
TA-TSV-1408,	Generic Requirements for Exchange PVC Cell Relay Service, Bellcore.
TA-TSV-1409,	Generic Requirements for Exchange Access PVC Cell Relay Service, Bellcore.
TR-NWT-000063,	Network Equipment Building System (NEBS) Generic Equipment Requirements, Bellcore.
TR-NWT-000078,	Generic Physical Design Requirements for Telecommunications Products and Equipment, Bellcore.
TR-NWT-000468,	Reliability Assurance Practices for Optoelectronic Devices in Central Office Applications, Bellcore.
TR-NWT-000496,	SONET ADM Equipment Generic Criteria, Bellcore.
TR-NWT-000499,	Transport Systems Generic Requirements (TSGR): Common Requirements, Bellcore.
TR-NWT-000815,	OTGR Section 2.3: Network Element and Network System Security, Bellcore.
TR-NWT-000930,	Generic Requirements for Hybrid Microelectronics Used in Telecommunications Equipment, Bellcore.
TA-NWT-000983,	Reliability Assurance Practices for Optoelectronic Devices in Loop Applications, Bellcore.
TR-NWT-001112,	Broadband-ISDN User to Network and Network Node Interface Physical Layer Generic Criteria, Bellcore.

TR-TSV-000772,	Generic System Requirements in Support of Switched Multi-Megabit Data Service, Bellcore.
TR-TSV-001369,	Generic Requirements for Frame Relay PVC Exchange Service, Bellcore.
TR-TSV-001370,	Generic Requirements for Exchange Access Frame Relay PVC Service, Bellcore.
TR-TSY-000454,	Supplier Documentation for Network Elements, Bellcore.

## List of Acronyms and Abbreviations

The acronyms and abbreviations used in this manual are detailed in the following list:

<b>155 CRS</b>	Dual port Optical Carrier card providing Cell Relay Service in a concatenated payload at a data rate of 155Mbps
<b>155 RIC</b>	Optical Carrier Ring Interface Card providing cell relay service in a concatenated payload at a data rate of 155Mbps
<b>622 RIC</b>	Optical Carrier Ring Interface Card providing cell relay service in a concatenated payload at a data rate of 622Mbps
<b>2488 RIC</b>	Optical Carrier Ring Interface Card providing cell relay service in a concatenated payload at a data rate of 2488Mbps
<b>ABR</b>	Available Bit Rate
<b>ADM</b>	Add / Drop Multiplexer
<b>AIC</b>	Access Interface Card
<b>AIS</b>	Alarm Indication Signal
<b>APS</b>	Automatic Protection Switching
<b>ATM</b>	Asynchronous Transfer Mode
<b>B-ICI</b>	Broadband Inter-Exchange Carrier Interface
<b>BPS</b>	Bits Per Second
<b>CAC</b>	Connection Admission Control
<b>CBR</b>	Constant Bit Rate
<b>CDV</b>	Cell Delay Variation
<b>CDVT</b>	Cell Delay Variation Tolerance
<b>CES</b>	Circuit Emulation Service
<b>CIR</b>	Committed Information Rate
<b>CO</b>	Central Office
<b>CPE</b>	Customer Premise Equipment
<b>CRS</b>	Cell Relay Service
<b>CTD</b>	Cell Transfer Delay
<b>DCC</b>	Data Communications Channel
<b>E1 TMUX Multi 1</b>	A 16 E1 port card that converts digital signals into ATM streams
<b>EIM</b>	Electrical Interface Module
<b>EPS</b>	Expansion Shelf
<b>ESF</b>	Extended Superframe
<b>FRS</b>	Frame Relay Service
<b>FTP</b>	File Transfer Protocol
<b>GNE</b>	Gateway Network Element
<b>GUI</b>	Graphical User Interface
<b>IP</b>	Internet Protocol

<b>LAN</b>	Local Area Network
<b>LEC</b>	Local Exchange Carrier
<b>LTE</b>	Line Terminating Equipment
<b>msec</b>	millisecond
<b>NDC</b>	Network Data Collection
<b>NE</b>	Network Element
<b>NIC</b>	Network Interface Card
<b>NMIC</b>	Network Management Interface Card
<b>NMS</b>	Network Management System
<b>NNI</b>	Network to Network Interface
<b>NPC</b>	Network Parameter Control
<b>OAM&amp;P</b>	Operations, Administration, Maintenance, and Provisioning
<b>OS</b>	Operations System
<b>PCR</b>	Peak Cell Rate
<b>PEIM</b>	Protection EIM
<b>PTE</b>	Path Terminating Equipment
<b>PVC</b>	Permanent Virtual Circuit
<b>QoS</b>	Quality of Service
<b>RIC</b>	Ring Interface Card
<b>SAM</b>	Service Access Multiplexer
<b>SC</b>	Shelf Controller card
<b>SCR</b>	Sustained Cell Rate
<b>SDH</b>	Synchronous Digital Hierarchy
<b>SEPIC</b>	Shelf ExPansion Interface Card
<b>SNMP</b>	Simple Network Management Protocol
<b>SONET</b>	Synchronous Optical NETwork
<b>SPE</b>	Synchronous Payload Envelope
<b>SRTS</b>	Synchronous Residual Time Stamp (patent 5260978 Bell Comm. Research)
<b>STM</b>	Synchronous Transport Mode
<b>STN</b>	Service Transport Node
<b>STS</b>	Synchronous Transport Signal
<b>STS-3c</b>	Concatenated STS-3 signal (one payload)
<b>SVC</b>	Switched Virtual Circuit
<b>T1</b>	Digital Signal Level 1
<b>T1 TMUX Multi 1</b>	A 16 DS1 port card that converts digital signals into ATM streams
<b>T3</b>	Digital Signal Level 3
<b>T3 CES</b>	Three port Digital Subscriber line card providing Circuit Emulation Service at a data rate of 45Mbps
<b>T3 CRS</b>	Three port Digital Subscriber line card providing Cell Relay Service at a data rate of 45Mbps
<b>T3 TMUX Multi 1</b>	A single DS3 port line card providing individual DS1 channel multiplexing
<b>TC</b>	Transmission Convergence
<b>TCA</b>	Threshold Crossing Alert
<b>TDM</b>	Time Division Multiplexer
<b>TEIM</b>	Terminating Electrical Interface Module
<b>TFTP</b>	Trivial File Transfer Protocol
<b>TID</b>	Target Identifier
<b>TMN</b>	Telecommunication Management Network



<b>UBR</b>	Unspecified Bit Rate
<b>UNI</b>	User Network Interface
<b>UPC</b>	Usage Parameter Control
<b>UPSR</b>	Unidirectional Path Switch Ring
<b>UVPSR</b>	Unidirectional Virtual Path Switch Ring
<b>VC</b>	Virtual Channel
<b>VCC</b>	Virtual Channel Connection
<b>VP</b>	Virtual Path
<b>VPC</b>	Virtual Path Connection
<b>VT</b>	Virtual Tributary
<b>W/P</b>	Working/Protect

## SECTION 1 INTRODUCTION

CONTENT .....	PAGE
1. GENERAL .....	1
2. USER INTERFACES.....	2
A. NMIC RS232 Interface .....	3
B. NMIC EIM RJ45 Ethernet Interface .....	3
C. NMIC Serial Equipment Port .....	4
3. CELLWORX STN SYSTEM SOFTWARE.....	4
A. NMIC Graphical User Interface (GUI) .....	4
GUI Screen Icon Definitions .....	5
GUI Menu Structure and Utilization .....	8
X-Terminal Keyboard Functions .....	12
Manipulating the GUI Network Layout on an X-Terminal Screen.....	12
4. REMOTE MANAGEMENT CAPABILITIES .....	13
A. Real Time Alarm and trap Screens .....	14

### 1. GENERAL

This section provides information on the Cellworx Service Transport Node's (STN) Graphical User interface (GUI) and alarm monitoring capabilities. Information in this document relates to the Release 3.1 design features of the Cellworx STN system. Future revisions of this document will cover added features and enhancements to the system and/or software.

The Cellworx STN system has been designed to accelerate the migration of networks to support broadband services. It is an Add/Drop Multiplexer (ADM) utilizing Asynchronous Transfer Mode (ATM) technologies to support access and delivery of emerging and legacy services. Through the use of simple transport provisioning, the Cellworx STN enables broadband services on an ATM backbone to coexist within the TDM infrastructure. A single platform is used to both deploy new services to thousands of customers, and provide significant bandwidth savings in existing networks. At the same time, it provides the utility and survivability that service providers have come to expect from true Telecom-oriented SONET products.

The Cellworx STN shelf is shown in Figure 1-1. It is available in a 19-inch or a 23-inch rack mount shelf that has specific card slot assignments for the Ring Interface Cards (RICs), Network Management Interface Cards (NMICs), and Shelf Controller cards (SCs). The intent of specific slot locations is to maximize bus performance and the number of working and protect pairs. The Cellworx STN can be used as a collocated or remote Expansion node utilizing 622, 155 or T3 CRS cards as links to a ring node to provide subscriber fan out or remote access capabilities to a ring. Certain card slots are keyed to prevent the installation of wrong card types into those slots. The remainder of the slots can accept any Access Interface Card (AIC) provided the proper Electrical Interface Module (EIM) is installed at the rear of the shelf for that AIC service type.

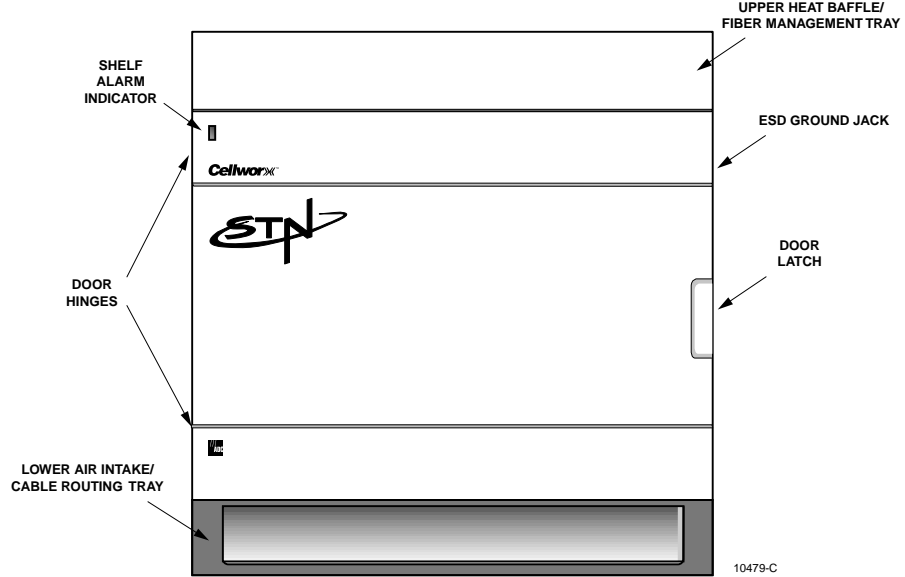

Figure 1-1. Cellworx STN Shelf

## 2. USER INTERFACES

The Network Management Interface Controller (NMIC) shown in Figure 1-2 provides a common ring and element management system platform where all aspects of network management are performed. The NMIC houses the operating system and application software for each node and card to provide Fault, Configuration, Performance, and Security management functions based on TMN principles at the Element Management Layer.

## A. NMIC RS232 Interface

The NMIC provides an asynchronous RS-232 port for character based access provided through a DB9 connector located under the front hinged faceplate. This port is used to load the operating system information and IP addresses at initial network turn up.

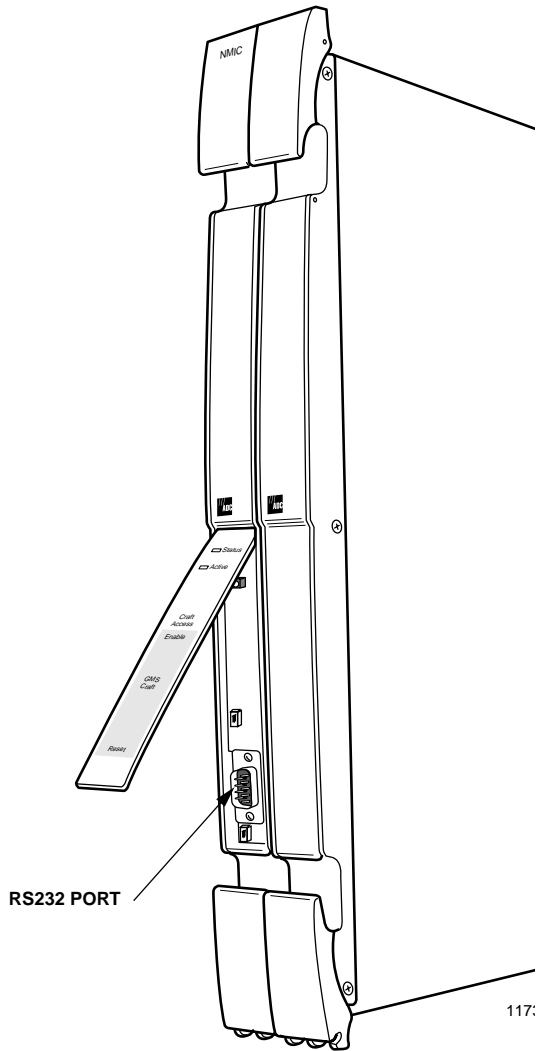

Figure 1-2. NMIC Craft Port Identification

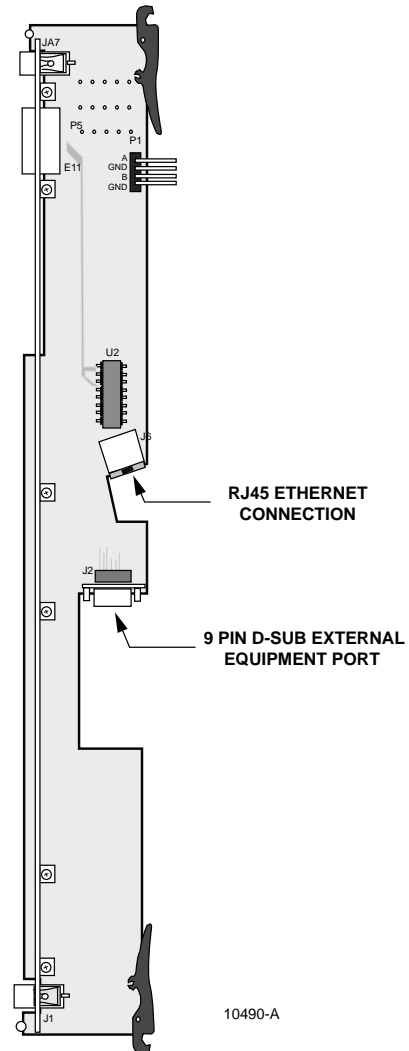

Figure 1-3. NMIC EIM Port Identifications

## B. NMIC EIM RJ45 Ethernet Interface

An external Network Management System (NMS) and/or X-Terminal connection is provided through an RJ45 10 Base-T Ethernet connection on either NMIC Electrical Interface Module (NMIC EIM) in slot 2 or 4 at the rear of the shelf. Refer to Figure 1-3. This connection is available only in the Gateway Network Element (GNE) located at a Central Office or controlled environment (0-50° C) location. It provides access to the GUI software screens for all management

functions, or SNMP access for Sets, Gets, Traps etc. Up to five GUI sessions may be launched at a time. An X-Terminal may remain active while the GUI is launched on another terminal. A user establishes a Telnet session to the NMIC to launch the GUI. The NMIC can maintain the Telnet session after the GUI is exited, or maintain the GUI functionality after the user terminates the Telnet session, but once both the Telnet session is terminated and the GUI is exited, the Telnet session must be re-established.

NMICs support 1:1 protection and provide independent Ethernet connections. Each NMIC has a unique IP address and a shared IP address, requiring the administrator to provision each of them on the X-Terminal. If the administrator cannot connect using the shared IP address (NMICs are unobtainable or a no response message is generated from a remote Telnet session connection attempt), the administrator can reattempt the Telnet session utilizing either the working or the protection NMIC IP addresses.

### **C. NMIC Serial Equipment Port**

A serial port is provided on the NMIC EIM that can be used for modem access or other types of serial equipment. This port will provide the same system access as the Ethernet port. It has jumpers that enable the user to strap the port for DTE or DCE depending on the serial device connected to it.

## **3. CELLWORX STN SYSTEM SOFTWARE**

### **A. NMIC Graphical User Interface (GUI)**

The Cellworx NMIC GUI interface provides a simple, consistent means of interaction through menu, mouse, and keyboard driven software configuration options. It is an executable program residing on the NMIC that a user gains access to through an X-Terminal window from the shell command prompt. The GUI retrieves data for the user initiated events via SNMP to the Application Core or by accessing the information stored on its hard disk.

Once connected to the NMIC and logged on to the network, a full network view encompassing each node in the network is displayed on the screen. An example is shown in Figure 1-4. An arrangement of icons representing Cellworx STN nodes reflect the network configuration (if configured) and are color-coded indicating the current alarm state of each node. Table 1-1 describes the color codes of the icons. The NE containing the NMICs is referred to as the Gateway Network Element (GNE) and can be determined at a glance from the yellow text underneath it. All other nodes will have white text.

The fiber connections shown between the nodes will appear green if there are no fiber fragment failures. They will turn orange in the event of a fiber fragment failure indicating a major alarm condition on the link between nodes.

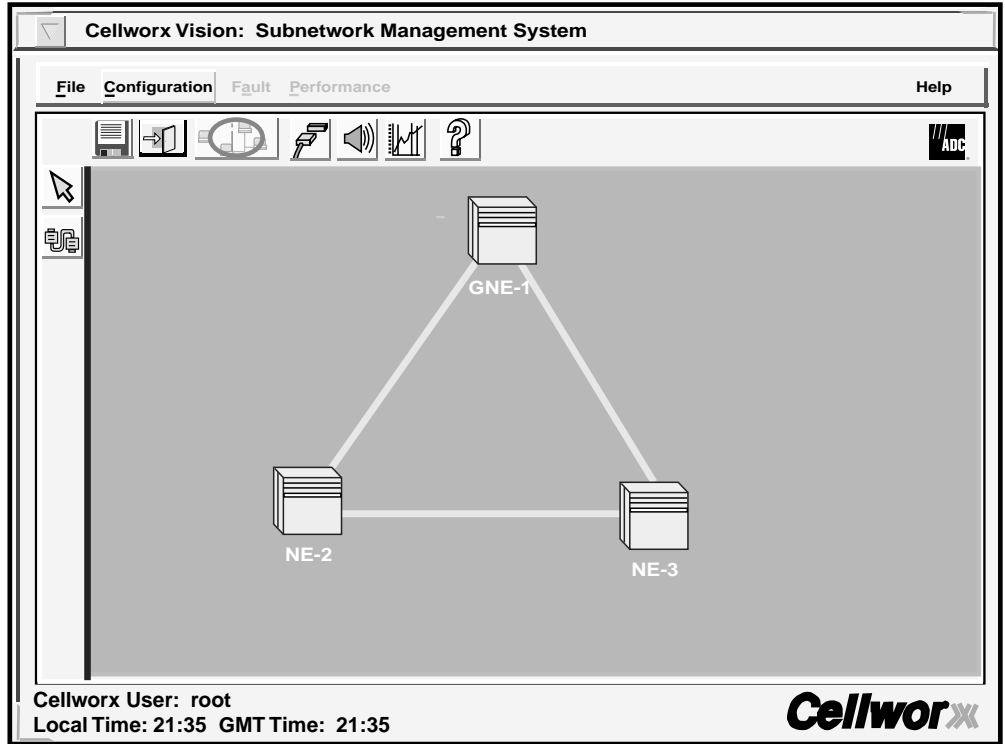

10924-D

Figure 1-4. Network Manager Main Screen

Table 1-1. GUI Cellworx STN Node Icon Color Codes

COLOR	INDICATION
Green	No existing alarms, normal operation.
Yellow	Minor alarms exist at this site.
Orange	Major alarms exist at this site.
Red	Critical alarms exist at this site.
Blue	Cannot communicate with the site.

### GUI Screen Icon Definitions

Larger icons are used to represent the Cellworx STN shelves that have Secondary nodes (expansion shelves called STN-EPS) connected to them. These icons are referred to as Primary nodes and will look the same whether there are 2 or 10 STN-EPS nodes connected to them. Refer to Figure 1-5. The Secondary nodes may be collocated or reside at remote sites. When a user selects a node, it is highlighted by a white square that surrounds it. By double clicking on one of these nodes with the left mouse button, a new window is displayed reflecting the interconnecting relationship between the Primary and Secondary nodes. It is at this point that the user can determine the number of nodes involved. Refer to Figure 1-6. The Primary node now appears as a normal size ICON and the ring network interconnections are not displayed. To return to the ring network view, the operator clicks on the Cancel button at the bottom of the window.

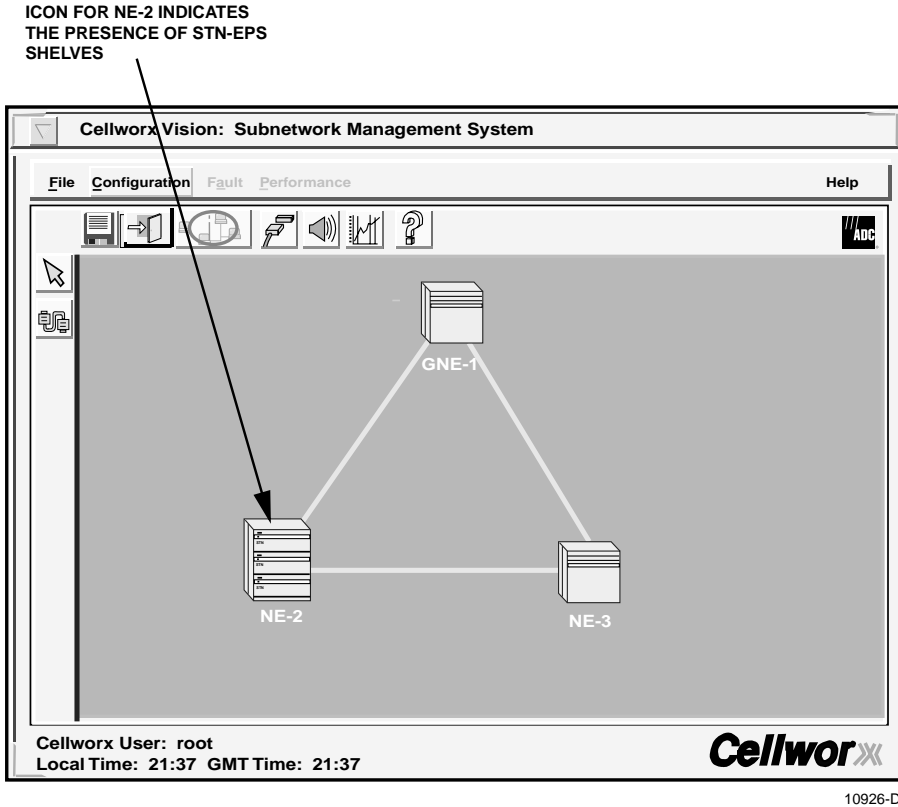

Figure 1-5. Example of Primary Node with Secondary Expansions

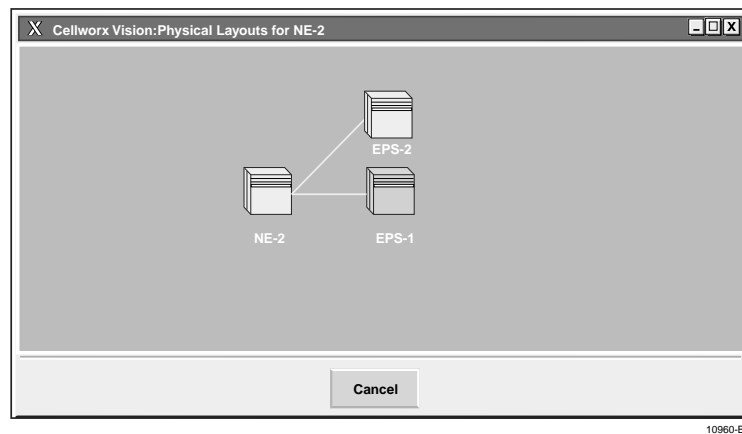

Figure 1-6. Primary Node Physical Layout to Secondary Nodes

An Auto Discovery feature allows the NMIC to search for and display all nodes connected in the network during initial system turn-up. Main menu headings are displayed at the top of the screen (File, Configuration, Fault, Performance) and when selected will allow the user to perform all higher level functions such as system administration, establish end to end VP/VC connections, request performance reports, or display network alarm summaries.

To access any node in the network, the administrator selects the direct selection arrow tool located on the left tool bar, and then double clicks on the NE ICON to open a shelf level GUI session. To start a craft session with the node, the user selects the node with a single click, right click to open the pop-up menu, and select Craft Interface. The administrator is required to enter a valid user name and password assigned for the node to gain access to the craft menus. The shelf level GUI is shown in Figure 1-7 below.

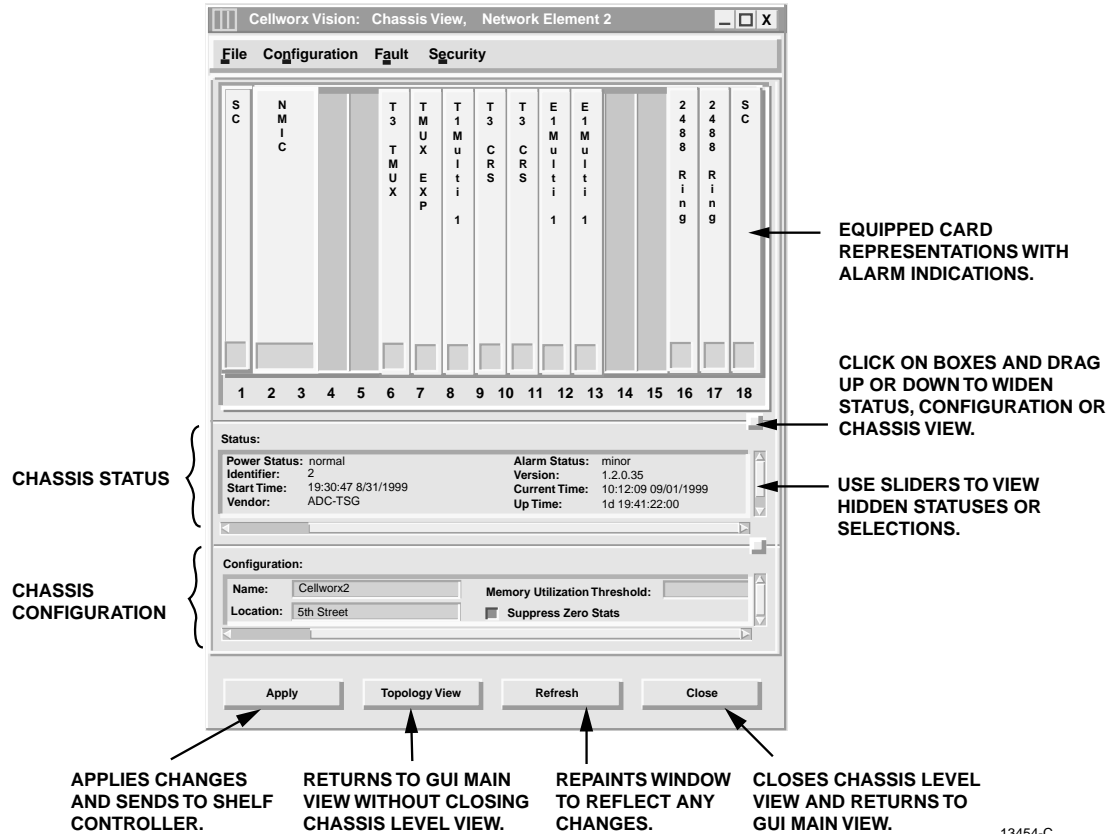
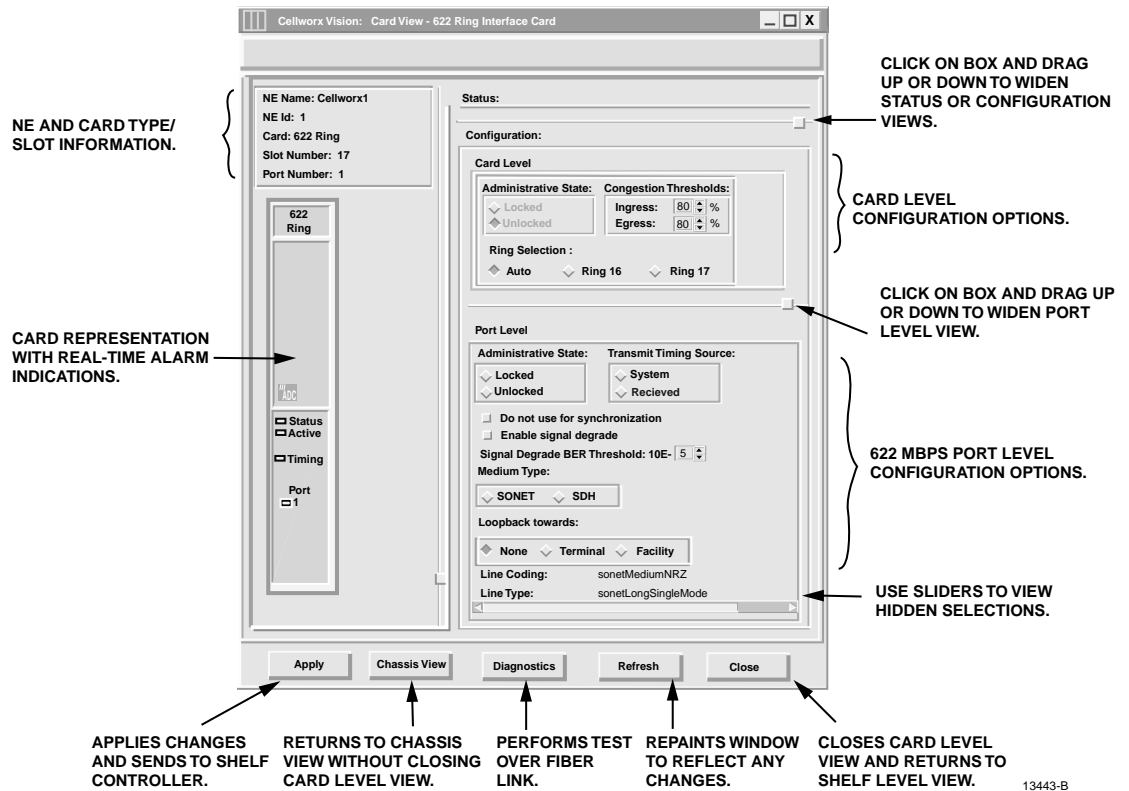

Figure 1-7. Cellworx Shelf Level GUI Screen

The user can now provision parameters on individual cards in the shelf. To bring up a card level GUI display, double click on the card displayed in the shelf level view or put the mouse pointer over the card and hit a right click to open a menu window for the card and select Open. The Card level view will appear similar to the example shown in Figure 1-8 below. Some functions available in this view are described in the figure.

13454-C





13443-B

Figure 1-8. Cellworx Vision Card Level View (622 Ring Interface Card example)

## GUI Menu Structure and Utilization

There are three possible methods for performing configuration tasks using the GUI; 1) utilizing the pull down menu trees, 2) mouse controlled popup menus, 3) keyboard operations. Refer to Figure 1-9 for examples.

- Using the mouse, click the right button over the work area to display the popup menu and select desired task using the left mouse button. This may bring up another pop up menu, depending on the task.
- Using the mouse, select a topic on the menu bar above the work area using the left mouse button. Select a task shown on the pull down menu using the left mouse button. This may bring up a pop up menu, depending on the task.
- Using the keyboard, select “Alt” plus the underlined letter of a topic shown on the menu bar above the work area. This opens the pull down menu from the menu bar. Using the arrow keys on the keyboard, step up or down to the desired task and hit enter, or return, or right arrow. Other pop up menus may be generated depending on the task.

SELECTING THE TOPIC USING THE LEFT MOUSE BUTTON, OR ALT PLUS THE UNDERLINED LETTER, OPENS THE PULL DOWN MENU LIST. SELECT OPTION USING LEFT MOUSE DOWN MENU LIST. SELECT OPTION USING LEFT MOUSE BUTTON OR DOWN ARROW FOLLOWED BY A RIGHT ARROW.

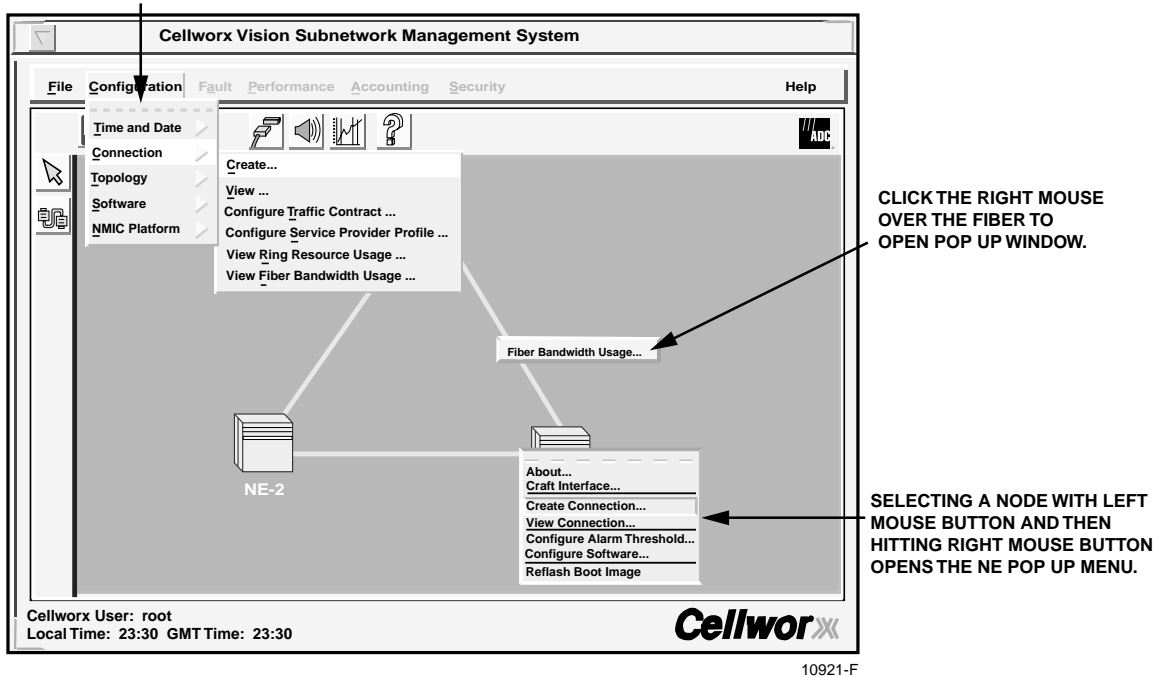
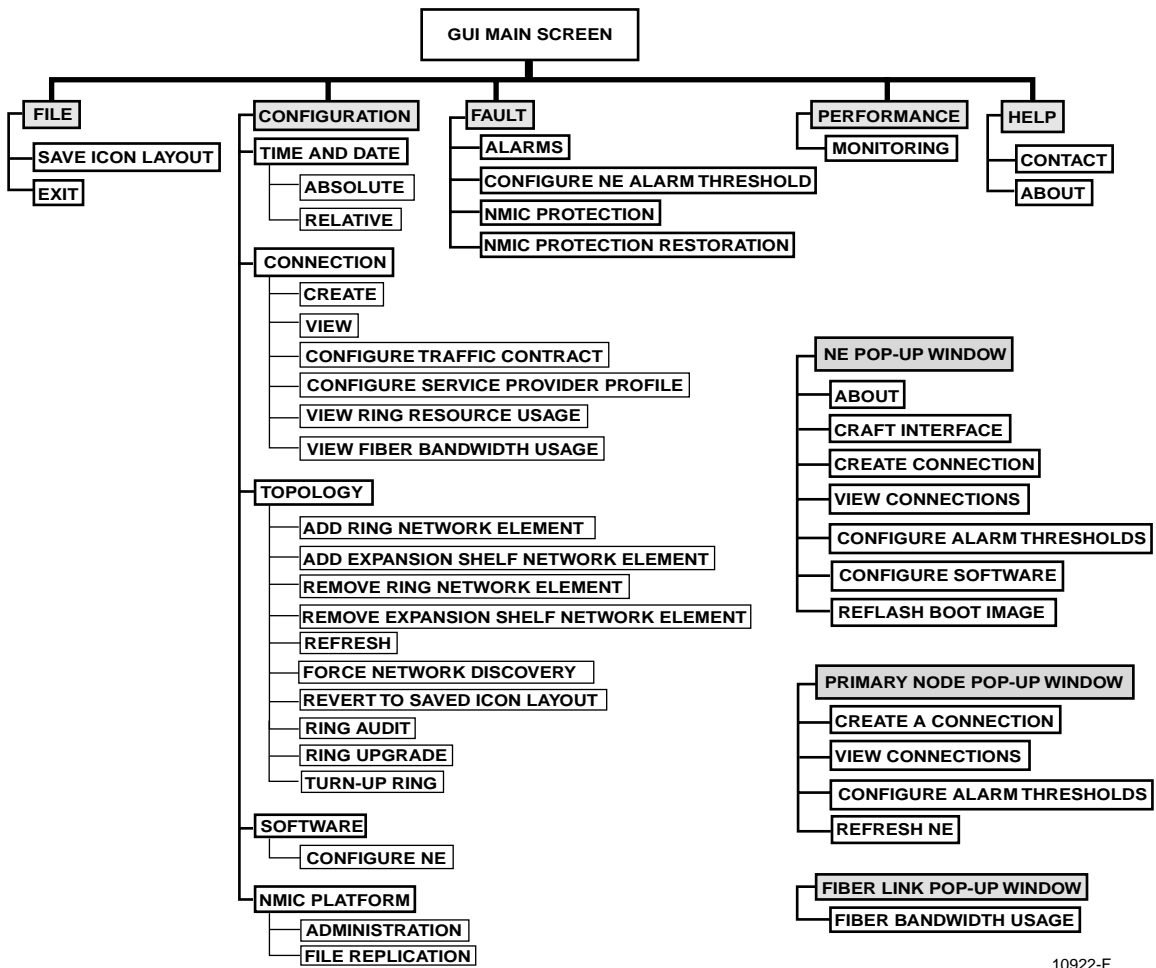

Figure 1-9. Cellworx STN GUI Display (sample)

The pull down menus and pop-up window menu structures for the main GUI screen are shown in the menu tree in Figure 1-10. The pull down menus for the Shelf level GUI is shown in Figure 1-11.



10922-F

Figure 1-10. Cellworx Vision Pull Down Menus and Pop-up Window Trees

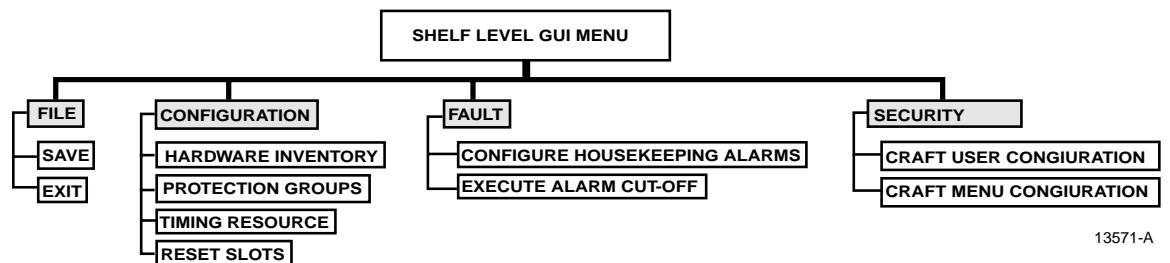

13571-A

Figure 1-11. Cellworx Shelf Level GUI Pull Down Menu Structure

Just outside the workspace the tool bar displays icons placed horizontally and vertically. These Icons provide shortcuts to common tasks for the advanced user. The functions of these icons are described in Figure 1-12.

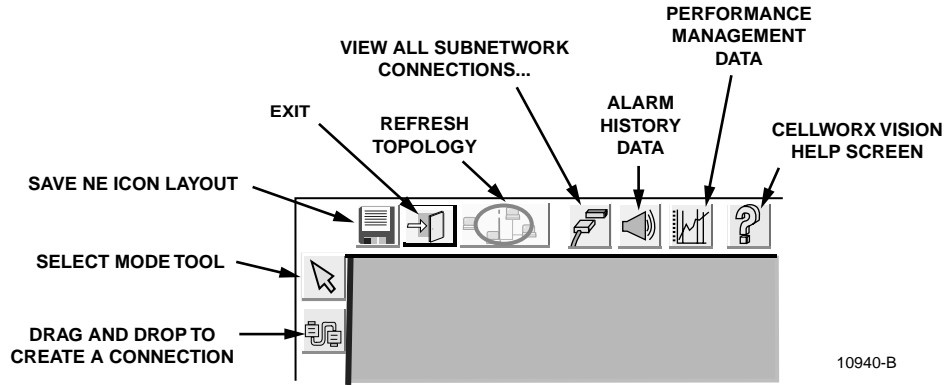







Figure 1-12. GUI Tool Bar Icon Definitions

While performing tasks, a user may encounter message windows, confirmation windows, and informational windows. Each window can be distinguished by the icon to the left as shown in Figure 1-13.

-  — INFORMATIONAL WINDOW INDICATING A TASK HAS BEEN COMPLETED, OR INSTRUCTING THE USER TO ENTER INFORMATION. GENERALLY REQUIRES THE USER TO SELECT "OK".
-  — HOURGLASS INDICATES A TASK IS IN PROGRESS AFTER CHANGES TO THE SYSTEM HAVE BEEN SENT BY THE USER.
-  — ERROR MESSAGE INDICATES THAT THE TASK COULD NOT BE COMPLETED DUE TO LACK OF INFORMATION, HARDWARE, COMMUNICATION, ETC.
-  — QUESTION ICON INDICATES THAT THE USER MUST THINK AND MAKE A SELECTION BEFORE CONTINUING.
-  — WARNING MESSAGE INDICATING A POTENTIAL PROBLEM, GENERALLY REQUIRES THE USER TO SELECT "OK".

10939-C

Figure 1-13. Cellworx Vision Window Icon Definitions

## X-Terminal Keyboard Functions

All of the functions that can be performed through pop up menus using the mouse can also be performed via the menu bar at the top of the screen. The menu bar provides pull down menus under these options: File, Configuration, Fault, and Performance.

The keyboard is used to select the menu bar items, navigate and select sub menu items, bring up the configuration or query screens, and when necessary, to enter alphanumeric information into the system. Keyboard operations for the GUI also make use of the arrow keys, enter or return key, tab key, space bar, and control key. The user must hit the Alt key along with the underlined letter of the menu item desired (ex. Alt + F selects the File menu tree).

By entering the tab key, the operator moves the highlighted or underlined selection to the next menu item (ex. File to Configuration.) Hitting the enter or return key opens the menu item. The operator may now use the arrow keys to step down or up to the desired item selection. The right arrow will bring up a sub menu if one exists, indicated by the arrow pointing to the right beside the text in the menu list.

## Manipulating the GUI Network Layout on an X-Terminal Screen

The user may redraw the layout of the network that is displayed by the GUI. This may be performed to set a group of nodes that are co-located apart from others, to place the nodes in a city or state map layout, or just to make use of more room on the screen itself. By selecting a node using the select mode tool and a single click and hold of the left mouse button, the operator can drag it to any area of the screen and then release the mouse button. The node is now planted in its new location on the screen and all of the connections stay intact (the operator cannot change the physical location or inter-connections between the nodes by moving an icon into another area of the software screen).

Once the user has redrawn the GUI screen layout, the new screen configuration should be saved. This can be done through the menu bar under File: Save Icon Layout, or by single clicking on the floppy disk icon on the tool bar above the work area.

#### 4. REMOTE MANAGEMENT CAPABILITIES

The X-Terminal used for operations and maintenance of the Cellworx STN network can be linked through existing customer Ethernet networks using TCP/IP over any transport layer (e.g. Frame Relay, ATM, Private Line, etc.) Refer to Figure 1-14 for an example.

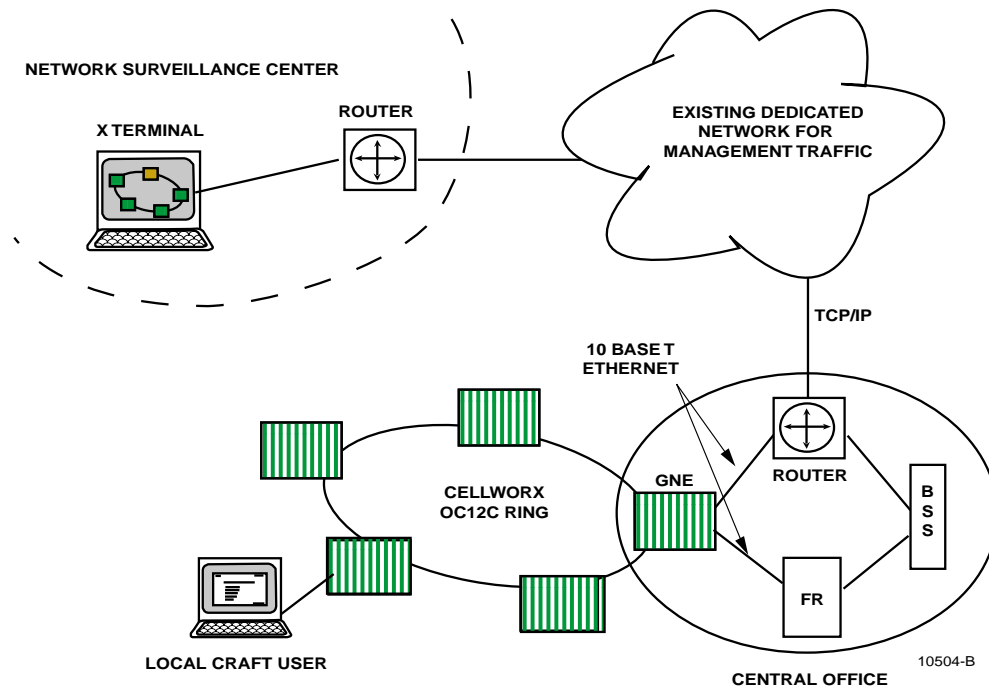

Figure 1-14. Remote X-Terminal Operations

The network operator can use any workstation with a standard X-Window platform or a PC with X-Terminal emulation to remotely access the network, launch the GUI, and monitor or troubleshoot the Cellworx STN ring network. The operator can remotely connect to a node via Telnet session through the NMIC, and use craft menus to retrieve alarm and performance information. These functions are performed utilizing IP addresses set up for each node at turn up.

Messaging between remote nodes and the GNE NMIC is performed by targeting the NE's IP address. Many existing network components (BSS, ATM Switches, frame relay switches, and routers) can also be pulled up on the same X-Terminal for maintenance and troubleshooting capabilities.

## A. Real-time Alarm and Trap Screens

The Cellworx NMIC provides real time alarm monitoring capabilities to an External Management System (EMS) via SNMP traps through an Ethernet port on the NMIC EIM. This scheme supports remote retrieval of NMIC collected data for user manipulation and report creation via ftp using four simple file types. These files are comma, space, or tab delimited and cover the following categories of collected data: Alarm history, Accounting, PM data, and Network Data Collection.

The NMIC serves as an ATM domain operations interface provided on a Cellworx STN shelf configured as a Gateway Network Element (GNE), generally located in the CO or manned site. The NMIC can process 1.6K TFTP (Trivial FTP)/FTP packets as well as 0.8Mbytes of data per second, serving as an FTP server for each of the NE Shelf Controllers (SCs). The alarm history from each of the NE SC traps is stored up to 24 hours for future queries. The NMIC sends an SNMP request to the destined NE based on legitimate SNMP requests received from the EMS, and discards all IP packets that are different from its IP address.

The SNMP MIB for ring management is ATM Forum network view M4 based. The NE processes up to ten SNMP traps per second also.

GR-1248, [213] is supported. The NMIC supports the user identification, authentication, system access control, resource access control, security log, and security administration requirements as stated in GR-1248 [213]. The administrator can configure the option of allowing the user to only perform SNMP get requests and receive SNMP traps.

## SECTION 2 OPERATION AND MAINTENANCE TOP

Content	Page
1. GENERAL .....	2-1
2. USING A TOP DOCUMENT.....	2-1
ALPHABETICAL TASK INDEX LIST .....	2-3
INSTALLATION TASK INDEX LIST.....	IXL-001

### 1 GENERAL

This section provides operation and maintenance procedures for the Cellworx Service Transport Node (STN) for the system administrator/operator.

Operation and maintenance includes but is not limited to the following tasks:

- Performing end to end signal tests to verify system operation.
- Adding modules to an in-service chassis.
- Configuring the modules for operation (S/W configuration and download).
- Configuring the VP/VC traffic connections for operation.
- Troubleshooting alarm conditions.
- Using the GUI interface to check network and node statuses.
- Performing card/traffic level switching for maintenance, troubleshooting, or testing purposes.

### 2 USING A TOP DOCUMENT

The procedures in this section are written in the Task Oriented Process (TOP) format. The TOP method of presenting information provides step by step instructions for the successful completion of the indicated task. To find the instructions for performing enclosure installation, module installation and initial turn up, and installation troubleshooting tasks, refer to Figure 2-1 for the flow chart of a TOPS document or proceed as follows:

1. Find the task to be performed in the Indexed Task List (**IXL-001**), or the Alphabetical Task Index List.
2. Locate the specified director level, detail level, or trouble clearing procedure. All procedures are in numerical order, regardless of type. The TOP procedures in this manual are of the following four types:
  - a) Non-Trouble Clearing Procedure (**NTP**) – A director level procedure that lists normal work items to be performed that are not trouble clearing procedures.
  - b) Trouble Analysis Procedure (**TAP**) – A director level procedure that provides step by step instructions to locate and fix problems.
  - c) Detailed Level Procedure (**DLP**) – Detailed step by step instructions or procedures.



- d) Trouble Analysis Data (**TAD**) – A trouble clearing aid containing non-procedural data.
  - 3. Perform all the items in the director level procedure (**NTP ‘or TAP**) in the order listed unless sent to another director level procedure. When a director level procedure is finished, the task is completed. When more detailed information is required, the reader will be sent to a DLP. A DLP may also direct the reader to another DLP.
- ◆ **Note:** When a DLP is complete, return to the procedure that preceded the DLP.
- ◆ **Note:** When sent from one DLP to another DLP, in most instances it will not be necessary to go back to the first DLP after completing the second.
- 4. In some procedures, it will be necessary to verify that certain responses have occurred. If the expected response is not observed, refer to the TAP. If additional data is required such as a schematic diagram, line drawing, tabulated data, maintenance philosophy, or trouble clearing strategy, the reader will be sent to a TAD.

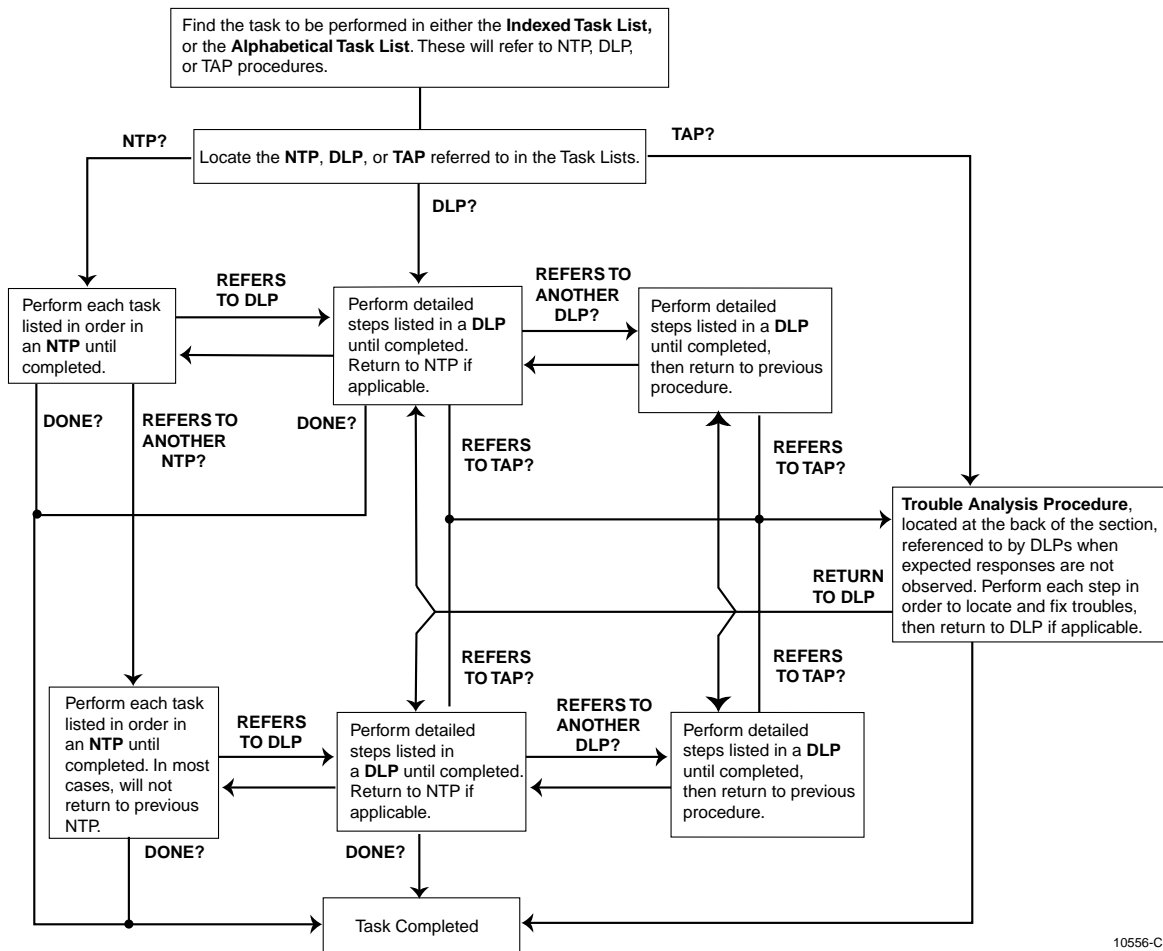

10556-C

Figure 2-1. TOPS Document Flow Chart

## ALPHABETICAL TASK INDEX LIST

Find Your Job in the List Below	Then Go To
ABOUT NE .....	DLP-721
ADD A CELLWORX STN NODE TO AN IN-SERVICE RING NETWORK .....	NTP-003
ADD A SECOND NETWORK ELEMENT TO AN IN SERVICE STAND-ALONE TERMINAL NODE TO CREATE A RING NETWORK .....	NTP-004
ADD/DELETE A LEAF ENDPOINT TO/FROM AN EXISTING MULTICAST CONNECTION .....	DLP-791
ADD/DELETE GUI USERS OR CHANGE GUI USER LEVEL SECURITY .....	DLP-783
ADD EXPANSION SHELF (STN-EPS) .....	DLP-712
ADD A RING NETWORK ELEMENT .....	DLP-737
ADD A SECOND NETWORK ELEMENT .....	DLP-738
ADD OR CHANGE AN SNMP TRAP HOST ON THE NMIC .....	DLP-775
ADDING SERVICES TO A CELLWORX STN NODE .....	NTP-009
ADMINISTRATIVE TASKS .....	NTP-015
ALARM CUT-OFF .....	DLP-776
CARD RESET .....	DLP-773
CHANGE CONFIGURATION/TEST AN EXISTING CONNECTION .....	DLP-723
CONDUCT ACCEPTANCE TESTS ON CELLWORX STN NODE .....	NTP-011
CONFIGURE CARD PROTECTION GROUPS .....	DLP-765
CONFIGURE NE ALARM THRESHOLD .....	DLP-717
CONFIGURE OR DELETE A TRAFFIC CONTRACT .....	DLP-709
CONFIGURE SERVICE PROVIDER PROFILE .....	DLP-714
CONNECT FIBERS TO OPTICAL CARDS .....	DLP-701
CONNECT NMS OR X-TERMINAL TO THE NMIC EIM SNMP/GUI PORT .....	DLP-704
CONNECT VT100 TO NMIC RS-232 PORT AND VERIFY NMIC IP ADDRESS .....	DLP-702
CREATE AN ATM OR CES CONNECTION .....	DLP-708
CREATE A FRAME RELAY CONNECTION .....	DLP-786
CREATE AN ATM BUNDLED VC MULTICASTING CONNECTION .....	DLP-790
CREATE AN ATM MULTICAST CONNECTION .....	DLP-787
DELETE A CELLWORX STN NODE .....	NTP-010
DELETE A CELLWORX STN NODE .....	DLP-740
DELETE A CELLWORX STN EXPANSION SHELF (EPS) .....	DLP-746
DELETE CONNECTIONS .....	DLP-739
DISPLAY NETWORK ALARM SUMMARY .....	DLP-713
DISPLAYING STATUS AND ALARMS .....	NTP-007
ENDING A GUI SESSION FOLLOWING AN ABNORMAL SESSION ENDING .....	DLP-778
FINDING AND CHANGING NMIC IP ADDRESS .....	DLP-774
FORCE NETWORK DISCOVERY .....	DLP-719
FTP DATABASE FILES OFF OF NMIC .....	DLP-782
HARDWARE INVENTORY .....	DLP-770

(continued)

## ALPHABETICAL TASK INDEX LIST, CONTINUED

Find Your Job in the List Below, continued	Then Go To
HELP .....	DLP-735
INITIATE A PROTECTION SWITCH .....	DLP-771
LAUNCH THE GRAPHICAL USER INTERFACE (GUI) .....	DLP-705
LOG OFF OF CELLWORX STN GRAPHICAL USER INTERFACE .....	DLP-711
LOG ON TO REMOTE NODE CRAFT SESSION VIA TELNET FROM GUI .....	DLP-703
LOOPBACK TEST .....	DLP-772
MONITORING THE NETWORK .....	NTP-014
NMIC PROTECTION .....	DLP-724
NMIC PROTECTION RESTORATION .....	DLP-725
NMIC SYSTEM FILE REPLICATION .....	DLP-722
PERFORM DIAGNOSTICS ON OPTICAL CARDS .....	DLP-766
PERFORM DISCOVERY ON A NEW CELLWORX STN RING NETWORK .....	DLP-706
PERFORM ROUTINE AND NON-ROUTINE MAINTENANCE .....	NTP-012
PHASE 3.0 TO 3.1 SOFTWARE UPGRADE PROCEDURE .....	DLP-795
PROVISION ATM VP AND VC CONNECTIONS .....	NTP-013
PROVISIONING NODE PARAMETERS .....	NTP-006
REFLASH BOOT IMAGE .....	DLP-744
REFRESH TOPOLOGY .....	DLP-718
REMOVE AND/OR REPLACE CELLWORX CARDS .....	DLP-777
REMOVING A NMIC CARD FROM THE SHELF .....	DLP-781
RETRIEVE 155 SM/MM CRS CARD STATUS .....	DLP-760
RETRIEVE 622 SM CRS CARD STATUS .....	DLP-796
RETRIEVE 155 RING INTERFACE CARD STATUS .....	DLP-763
RETRIEVE 622 RING INTERFACE CARD STATUS .....	DLP-759
RETRIEVE 2488 RING INTERFACE CARD STATUS .....	DLP-779
RETRIEVE COMPRESSED LOGS FROM THE NMIC VIA FTP .....	DLP-742
RETRIEVE FE1 FRS CARD STATUS .....	DLP-789
RETRIEVE FT1 FRS CARD STATUS .....	DLP-788
RETRIEVE LOGS FROM THE NMIC VIA FTP .....	DLP-741
RETRIEVE NETWORK DATA COLLECTION (NDC) STATISTICS .....	DLP-730
RETRIEVE PERFORMANCE MONITORING STATISTICS VIA NMIC GUI .....	NTP-008
RETRIEVE SC CARD STATUS .....	DLP-757
RETRIEVE T1 MULTI 1 CARD STATUS .....	DLP-764
RETRIEVE T3 CES CARD STATUS .....	DLP-793
RETRIEVE T3 CRS CARD STATUS .....	DLP-761
RETRIEVE T3 TMUX MULTI 1 CARD STATUS .....	DLP-762
REVERT TO SAVED ICON LAYOUT .....	DLP-736
RING UPGRADE PROCEDURE .....	DLP-731

(continued)

## ALPHABETICAL TASK INDEX LIST, CONTINUED

Find Your Job in the List Below, continued	Then Go To
SET 622 SM CRS CARD CONFIGURATION .....	DLP-797
SET 155 SM/MM CRS CARD CONFIGURATION .....	DLP-752
SET 155 RING INTERFACE CARD CONFIGURATION .....	DLP-758
SET 622 RING INTERFACE CARD CONFIGURATION .....	DLP-751
SET 2488 RING INTERFACE CARD CONFIGURATION .....	DLP-756
SET CRAFT MENU CONFIGURATION .....	DLP-769
SET CRAFT USER CONFIGURATION .....	DLP-768
SET E1 MULTI 1 CARD CONFIGURATION .....	DLP-747
SET FE1 FRS CARD CONFIGURATION .....	DLP-784
SET FT1 FRS CARD CONFIGURATION .....	DLP-785
SET / RETRIEVE OPTICAL PORT PERFORMANCE MONITORING STATISTICS .....	DLP-726
SET / RETRIEVE T1/E1 MULTI 1 PERFORMANCE MONITORING STATISTICS .....	DLP-729
SET / RETRIEVE FT1 FRS PERFORMANCE MONITORING STATISTICS .....	DLP-732
SET / RETRIEVE FE1 FRS PERFORMANCE MONITORING STATISTICS .....	DLP-733
SET / RETRIEVE T3 CES PORT PERFORMANCE MONITORING STATISTICS .....	DLP-794
SET / RETRIEVE T3 CRS PORT PERFORMANCE MONITORING STATISTICS .....	DLP-728
SET / RETRIEVE T3 TMUX PERFORMANCE MONITORING STATISTICS .....	DLP-727
SET SC CARD CONFIGURATION (IP ADDRESS, CRAFT INTERFACE) .....	DLP-748
SET SHELF HOUSEKEEPING ALARM CONFIGURATION .....	DLP-750
SET SHELF TIMING RESOURCE .....	DLP-749
SET SYSTEM IDENTIFIER .....	DLP-767
SET T1 MULTI 1 CARD CONFIGURATION .....	DLP-755
SET T3 CES CARD CONFIGURATION .....	DLP-792
SET T3 CRS CARD CONFIGURATION .....	DLP-753
SET T3 TMUX MULTI 1 AND TMUX EXP CARD CONFIGURATION .....	DLP-754
SOFTWARE FALLBACK FROM 3.1 TO 3.0 .....	DLP-798
SOFTWARE SELECTION .....	DLP-720
SYSTEM DATABASE ACCESS .....	DLP-745
TIME AND DATE .....	DLP-707
TROUBLE ANALYSIS PROCEDURE .....	TAP-100
TURN UP A NEW CELLWORX STN RING NETWORK .....	NTP-002
TURN UP (PROVISION) CELLWORX STN EXPANSION SHELVES .....	NTP-005
VIEW CONNECTIONS .....	DLP-710
VIEW FIBER BANDWIDTH USAGE .....	DLP-716
VIEW RING RESOURCE USAGE .....	DLP-715

**INDEXED TASK LIST**

Find Your Job in the List Below	Then Go To
TURN UP A NEW CELLWORX STN RING NETWORK .....	NTP-002
ADD A CELLWORX STN NODE TO AN IN-SERVICE RING NETWORK.....	NTP-003
ADD A SECOND NETWORK ELEMENT TO AN IN-SERVICE STAND-ALONE TERMINAL TO CREATE A RING NETWORK .....	NTP-004
TURN UP (PROVISION) CELLWORX STN EXPANSION SHELVES.....	NTP-005
PROVISION NODE PARAMETERS .....	NTP-006
DISPLAYING STATUS AND ALARMS .....	NTP-007
RETRIEVE PERFORMANCE MONITORING STATISTICS .....	NTP-008
ADDING SERVICES TO A CELLWORX STN NODE .....	NTP-009
DELETE A CELLWORX STN NODE (RNE OR EPS).....	NTP-010
CONDUCT ACCEPTANCE TESTS ON CELLWORX STN NODE.....	NTP-011
PERFORM ROUTINE OR NON-ROUTINE MAINTENANCE .....	NTP-012
CREATING CONNECTIONS .....	NTP-013
MONITORING THE NETWORK.....	NTP-014
ADMINISTRATIVE TASKS.....	NTP-015
CELLWORX UPGRADE PROCEDURES .....	NTP-016

## TURN UP A NEW CELLWORX STN RING NETWORK

**Summary:** This procedure covers initial ring network turn-up. Provisioning of the ring nodes and interfaces as well as adding STN-EPS shelves to the ring nodes is covered in other NTPs. All ring nodes should be powered on and fiber continuity established between them, completing the ring architecture (see Installation Guide) before attempting to perform this procedure. Ring network turn up is originated at the GNE (Gateway Network Element) containing the NMIC cards. The NMIC card(s) in the GNE contain the proper Operating System and software from the factory, which must be initialized and loaded from the hard drive. Once the GNE is initialized, and the other ring nodes are discovered, the NMIC cards can download the required software loads to the shelf controllers in the remote ring nodes.

- ◆ **Note:** If adding a new node to an existing ring network, go to NTP-003.
  - ◆ **Note:** If adding a node to an in-service stand alone terminal or Service Access Multiplexer (SAM) to form a ring, go to NTP-004.
  - ◆ **Note:** If adding expansion shelves to existing nodes, go to NTP-005.
1. Verify NMICs are inserted.
  2. Verify all shelf controllers and AICs are installed and nodes are powered on. If not powered, perform power on procedures. DLP-700
  3. Verify that the GNE node, ring nodes, expansion nodes, and/or SAM/DSLAM nodes are properly identified by the thumbwheel switch settings on the SC terminating EIM (TEIM) at the rear of the shelf in slot 18. Refer to the Phase 3.1 Cellworx Installation Manual listed in the preface of this document. 1152693
  - ◆ **Note:** If the ID switches are reset then the SC must be hard reset using the Reset buttons under the front hinged panel.
  4. All RIC cards should have fibers connected with one ring in a clockwise direction, and the other in a counter-clockwise direction. If fibers are not installed, install per local practices and connect to optical cards. DLP-701
  5. Obtain the IP address of the NMIC. If the IP address is not set, connect a VT100 Terminal to the NMIC RS232 port and set the IP address for the GNE. Call the Customer Service number at the back of this manual if the address has already been set. DLP-702
  6. Connect an Ethernet cable to the NMIC Ethernet port on the NMIC EIM (Electrical Interface Module) at the rear of the shelf. DLP-704
  - ◆ **Note:** The NMIC will boot and download slot 1 shelf controllers in each ring NE. The slot one SC in each node then downloads to each slot 18 SC.

**NTP-002****Page 2 of 2**

7. Launch the Cellworx Vision Graphical User Interface (GUI). DLP-705
8. After the GUI boots up, it will prompt the user to synchronize the database. Choose the active NMIC's database as the correct database to synchronize.
9. Perform a discovery for a new Cellworx STN ring network. DLP-706
10. Set the Date and Time on the NMIC. DLP-707
11. Set the System Identifier for each node. DLP-767
12. After all nodes are successfully discovered, configure them before adding any expansion shelves. Configuration may include timing configuration, locking ports to remove LOS alarms, configuring the max VC bits to greater than zero to allow VC connections for each port, etc. NTP-006
13. Refresh the GUI screen so the nodes will display the new names. DLP-718
14. Perform acceptance tests on the new nodes per local requirements. NTP-011
15. Add expansion shelves to the ring nodes if equipped. NTP-005
16. Save the NMIC database. DLP-745

**Stop! You have completed this procedure.**

## ADD A CELLWORX STN NODE TO AN IN-SERVICE RING NETWORK

**Summary:** This procedure describes the steps required to add a new Cellworx STN ring node to a ring network that has previously been configured and may currently be passing traffic. Due to the protection operation of the unidirectional path switched ring (UPSR) architecture, adding a new ring node to an in-service network can be accomplished without affecting traffic or performance. Before performing this procedure, the new shelves and hardware should be installed and powered on per the instructions provided in the Cellworx STN Installation Manual 1152693. If adding a second node or multiple nodes to a standalone terminal to form a ring, you must first perform NTP-004. The procedure for adding a second network element to a standalone terminal or SAM is different from adding a new NE to an established ring network.

1. Launch the Cellworx Vision GUI from the X-Terminal. DLP-705
2. If an abnormal GUI session ending occurred from operator error, time out, or other unforeseen events, it might be necessary to free up the GUI and log back in. DLP-778
3. Add the Cellworx STN shelves to the ring. The shelf ID switches should have been set during installation and recorded on the label provided inside the front door panel. Follow the detailed instructions carefully to ensure the traffic on the ring is not interrupted. DLP-737
4. Configure the node parameters. NTP-006
5. Refresh the network topology (layout) on the GUI screen. DLP-718
6. Perform acceptance tests on the new nodes per local requirements. NTP-011
7. Add expansion shelves to the new node(s) if equipped. NTP-005
8. Save NMIC database. DLP-745

**Stop! You have completed this procedure.**



**ADD A SECOND NETWORK ELEMENT TO AN IN-SERVICE STAND-ALONE  
 TERMINAL TO CREATE A RING NETWORK**

**Summary:** This procedure describes the steps required to add a new Cellworx STN node to an in-service, Service Access Multiplexer (SAM) node or stand-alone terminal to create a two node ring. Only the second node in a network may be added using this procedure. If adding additional nodes (third, fourth, etc.) to a ring system, perform NTP-003.

1. Verify the new node is powered on. If not, perform power on procedures at the location. DLP-700
2. Verify the new node has the required RIC cards physically installed and fibers are connected. Refer to the Cellworx Installation manual listed in the preface of this document for card installation or use the fiber procedure to install fibers. DLP-701
3. Launch the Cellworx Vision GUI from the X-Terminal. DLP-705
4. If an abnormal GUI session ending occurred from operator error, time out, or other unforeseen events, it might be necessary to free up the GUI and log back in. DLP-778
5. If adding a node to a SAM to form a ring, change the shelf type (from a 6 to a 1) to a ring node via the thumbwheel switch on the SC terminating EIM (TEIM). It can be located at the rear of the shelf in slot 18. Refer to the Phase 3.1 Cellworx Installation Manual listed in the preface of this document. Otherwise, go to step 7. 1152693
6. Verify the RICs are installed in the SAM node and then perform a hard reset on the SCs so they will read the new shelf type. This will be traffic affecting. DLP-773
5. Add the Cellworx STN shelf to the standalone node. The shelf IDs of the new node should have been set during installation and recorded on the label provided on the inside of the front door panel. DLP-738
6. Configure the node parameters. NTP-006
7. Perform acceptance tests on the new node. NTP-011
8. Add an expansion shelf to the new node if equipped. NTP-005
9. Save the NMIC database. DLP-745

**Stop! You have completed this procedure.**

**TURN UP (PROVISION) CELLWORX STN EXPANSION SHELVES**

**Summary:** This procedure describes the steps required to add a Cellworx STN expansion shelf (STN-EPS) to an in-service ring node or one that has just completed the initial discovery process.

- **Note:** Applications using the 19-inch chassis will show card slots 1 through 18 but only card slots 1 through 11 and 16 through 18 are programmable.

Prerequisites to this procedure are:

- Ring node must be in-service and fibers correctly installed to the expansion shelf.
  - Shelf ExPansion Interface Cards (SEPICs) cards must be installed and in-service in the ring node.
  - Shelf ExPansion Interface Cards (SEPICs) must be installed in the expansion shelf.
  - Expansion shelf must have shelf type set to 03 for expansion NE. This is accomplished by the thumbwheel switch on SC TEIM in slot 18 at the rear of the shelf and should have been set during shelf installation procedures. If shelf type is changed, SC card must be reset using the button under the front hinged faceplate. Refer to the Installation Manual 1152693.
1. Ensure there is not a Level 1 GUI user logged onto the system. If necessary, force the user session off using the following procedure: DLP-778
  2. Launch the Cellworx Vision GUI from the X-Terminal. DLP-705
  3. Double click on the icon representing the ring node that will have the expansion shelf (STN-EPS) added to it. This will open a shelf level GUI window for the node.
  4. Verify that the expansion shelf interfaces in the ring node are equipped and in-service. To do this, double click on each simulated interface card shown on the shelf level GUI display. Equipped, in-service cards should have a green status indication at the bottom of the faceplate on the display.
  5. If the expansion shelf interface cards are not installed, refer to the Cellworx STN Installation Manual for card installation procedures. 1152693
  6. Verify the cards are configured as Shelf Expansion Interfaces for either of the following:
    - 155 SM/MM CRS cards DLP-752
    - 622 SM CRS cards DLP-797
    - T3 CRS cards DLP-753

**NTP-005****Page 2 of 2**

- **Note:** The shelf controller in slot 1 on the expansion shelf will begin to download. The shelf controller does not need to download completely before proceeding to the next step.
7. If using a 1+1 protection configuration, create a bi-directional protection group at the ring NE for a working and protect pair hosting the expansion shelf, otherwise continue. DLP-765
  8. Return to the GUI main screen by hitting *Close* on each window opened.
  9. Add the STN-EPS shelves to the system using the Cellworx Vision GUI. DLP-712
  10. Change the system name and location to a unique value for the expansion shelf. At this point the user may also want to properly configure the various settings for the node. This may include timing configuration, locking ports to remove LOS alarms, configuring the max VC bits to greater than zero to allow VC connections for each port, etc. NTP-006
  11. If using a 1+1 configuration, create a bi-directional protection group at the EPS for the working and protect shelf expansion interface cards linking to the ring NE, otherwise continue. DLP-765
  12. Choose the update topology button on the GUI to refresh the screen. The NEs should display the new name of the expansion shelf. DLP-718
  13. Repeat steps 3 through 12 for each STN-EPS shelf.
  14. Perform acceptance tests on the new nodes. NTP-011

**Stop! You have completed this procedure.**

## **PROVISION NODE PARAMETERS**

**Summary:** This procedure outlines the steps required to assign operational and administrative parameters within each node such as Node ID, port addresses, card configurations, etc., using the shelf level Graphical User Interface (GUI) available with Phase 3.1 software. This procedure is divided into the following headings:

- A. Shelf Parameters
- B. Card Configurations
- C. Card Performance Monitoring Parameters

Pre-requisites to this procedure are:

- User must be logged into the system and have GUI launched
- Node to be provisioned must be Discovered and visible to the GUI

► **Note:** In a 19-inch shelf, slot 12 through 15 will always show up as “grayed out” and the last three slots will always be treated as slots 16, 17, and 18 even though there are physically only 14 slots available.

### **A. SHELF PARAMETERS**

1. From the GUI main window, double click on the node to be provisioned using the left mouse button. This will launch a session with the node producing a chassis view similar to the one shown in Figure 006-1.

**NTP-006**  
**Page 2 of 5**

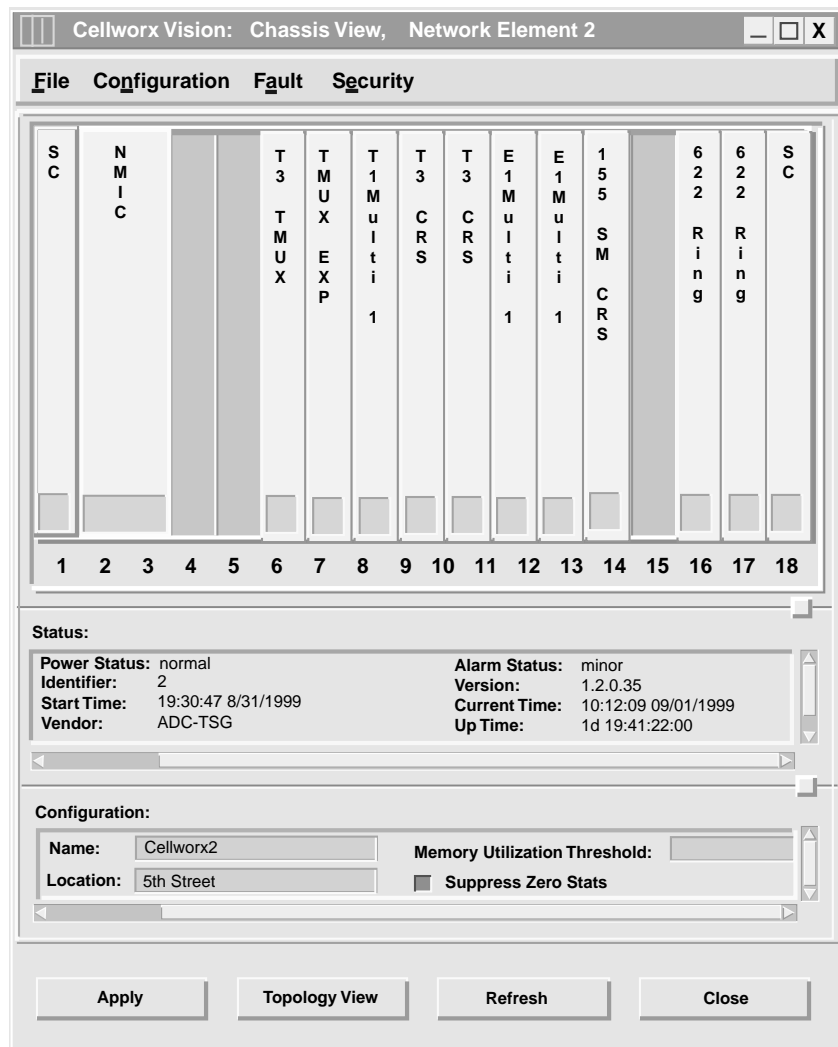

13455-B

**Figure 006-1. Shelf Level GUI Display**

2. If not already set, enter the NE system identifier by typing a node *Name* under the Configuration section of the window. A name may consist of up to 20 alphanumeric characters.
3. Enter the address of the node in the *Location* field. After entering information, send to database by clicking on the *Apply* button at the bottom of the window.
4. Set the SC card configurations (Serial port/ IP address.) DLP-748
5. Select a timing resource for the NE via the shelf level GUI. DLP-749
6. Set the shelf housekeeping alarm configuration. DLP-750

## B. CARD CONFIGURATIONS

7. Card configuration screens may be accessed from the shelf level GUI Chassis View window by double clicking on the card desired. Select a card and refer to the following card level GUI procedures to set the configuration options for that specific card type:
  - Set the E1 Multi 1 card configuration options. DLP-747
  - Set the 622 RIC card configuration options. DLP-751
  - Set the 155 SM/MM CRS (OC3) card configuration options. DLP-752
  - Set the 622 SM CRS (OC12) card configuration options. DLP-797
  - Set the T3 CRS card configuration options. DLP-753
  - Set the T3 TMUX MULTI 1 configuration options. DLP-754
  - Set the T1/E1 MULTI 1 card configuration options. DLP-755
  - Set the 2488 RIC card configuration options. DLP-756
  - Set the 155 RIC configuration options. DLP-758
  - Set the FE1 FRS card configuration options. DLP-784
  - Set the FT1 FRS card configuration options. DLP-785
  - Set the T3 CES card configuration options. DLP-792
8. Configure card protection groups, if applicable, for each access interface card type. DLP-765
9. Verify that the required cards show that they are equipped and in-service by observing the shelf level GUI screen. Any cards not provisioned for service will show up as “grayed out”. If any required cards are grayed out, return to the correct procedure outlined in Step 7 of this NTP, otherwise “Close” the chassis view and continue with step 10.
  - ▶ **Note:** In a 19-inch shelf, slot 12 through 15 will always show up as “grayed out” and the last three slots will always be treated as slots 16, 17, and 18 even though there are physically only 14 slots available.
10. Set the alarm level threshold for the shelf. DLP-717
11. Repeat this procedure for each shelf in the ring.

**NTP-006**  
Page 4 of 5

**C. PERFORMANCE MONITORING PARAMETERS**

1. From the GUI main screen, select the *Performance* pull down menu and then *Monitoring* using the left mouse button or by hitting *Alt+P* and *Alt+M*. See Figure 006-1. User may also use the graph icon shown on the tool bar above the workspace.

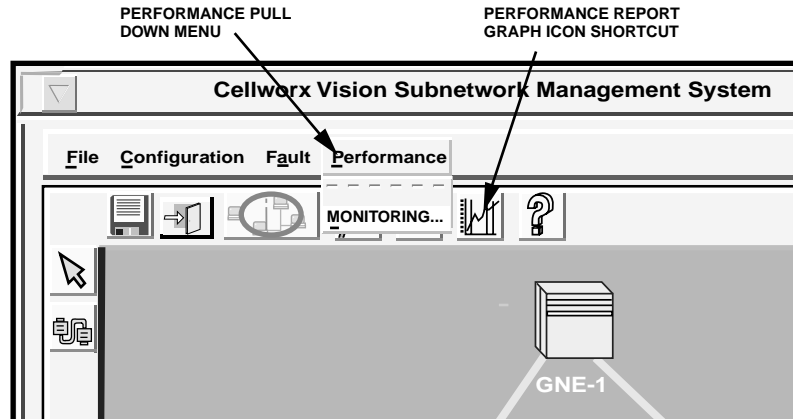

11744-C

**Figure 006-1. Cellworx Vision Performance Pull Down Menu**

2. The Cellworx Vision Performance Monitoring - Selection window appears as shown in Figure 006-2. In the upper left selection box, select a network element, card type, port, layer, and interval, followed by *Apply* at the bottom of the window.

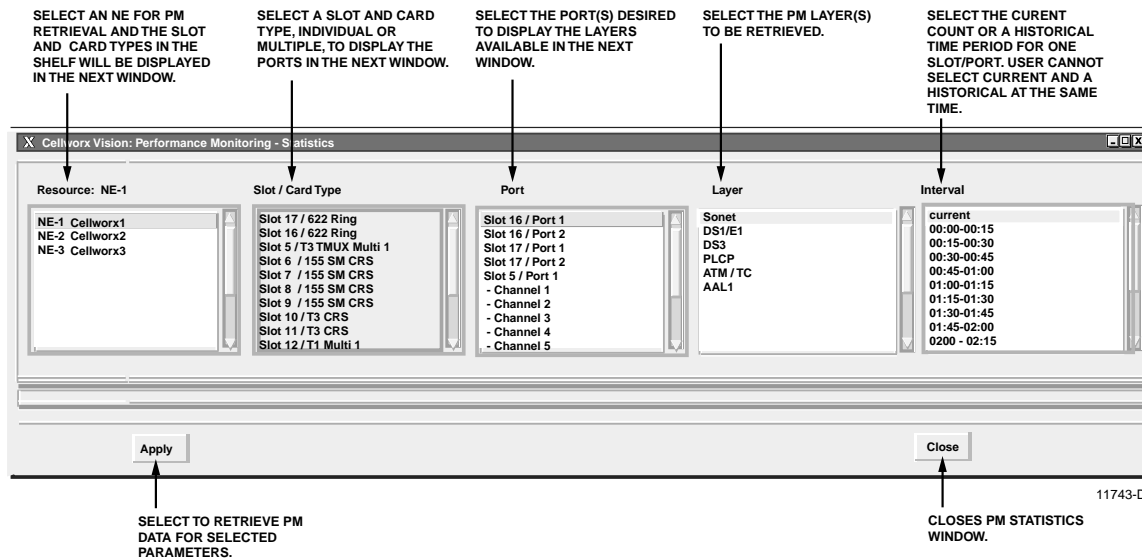

11743-D

**Figure 006-2. Cellworx Vision Performance Monitoring - Selection Window**

3. Refer to the following procedures to set the PM thresholds for each card type:

- Set Optical Port Performance Monitoring Statistics DLP-726
- Set T3 TMUX Performance Monitoring Statistics DLP-727
- Set T3 CRS Port Performance Monitoring Statistics DLP-728
- Set T1/E1 Multi 1 Port Performance Monitoring Statistics DLP-729
- Set FT1 FRS Port Performance Monitoring Statistics DLP-732
- Set FE1 FRS Port Performance Monitoring Statistics DLP-733
- Set T3 CES Port Performance Monitoring Statistics DLP-792

**Stop! You have completed this procedure.**



**NTP-007**  
**Page 1 of 3**

## DISPLAYING STATUS AND ALARMS

**Summary:** This procedure details the steps required to retrieve network alarms or shelf level alarms to isolate problems within the network. If alarms are present on the system, the Chassis View screen can help isolate which slots are affected. A shelf status display can help the systems administrator get a visual overview of which cards, alarms, protection groups, and cell busses are active, equipped, or Out of Service (OOS). The user can also go to individual card screens to obtain status information on individual card failures. These screens will give more detail on a per card basis.

### DISPLAYING ALARMS

1. Launch the Cellworx Vision GUI from the X-Terminal. DLP-705
2. If an abnormal GUI session ending occurred from operator error, time out, or other unforeseen events, it might be necessary to free up the GUI and log back in. DLP-778
3. Display the network alarm summary via the Cellworx Vision GUI. Determine the NE with the highest level of alarm and continue. DLP-713
4. Double click on the icon representing the node with the highest level of alarm. If it is configured as a primary node having expansion shelves (EPSs) configured off of it, a screen resembling the one shown in Figure 007-1 will appear.

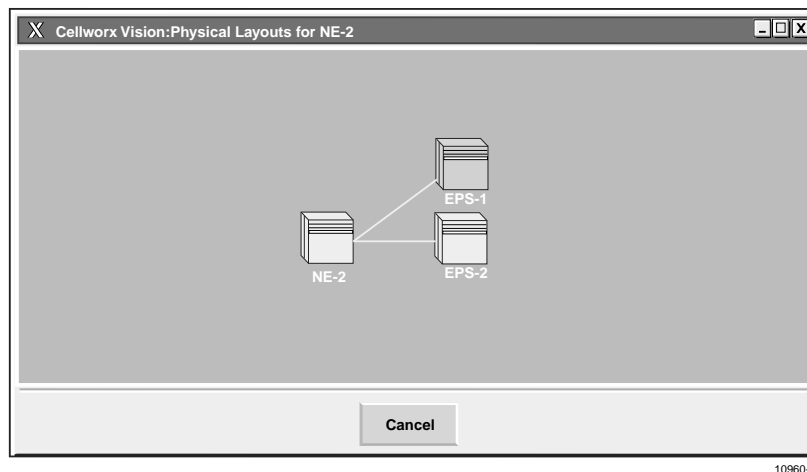

**Figure 007-1. GUI Primary Node Selection View (example)**

**NTP-007**

**Page 2 of 3**

5. Again, double click on the node with the highest level of alarm (red, then yellow) whether a Primary (NE-2) or Expansion node (EPS-1 or EPS-2 in this example).
6. The screen shown in Figure 007-2 appears showing the Chassis View and all cards associated with it.

► **Note:** Applications using the 19-inch chassis will show card slots 1 through 18 but only card slots 1 through 11 and 16 through 18 are programmable.

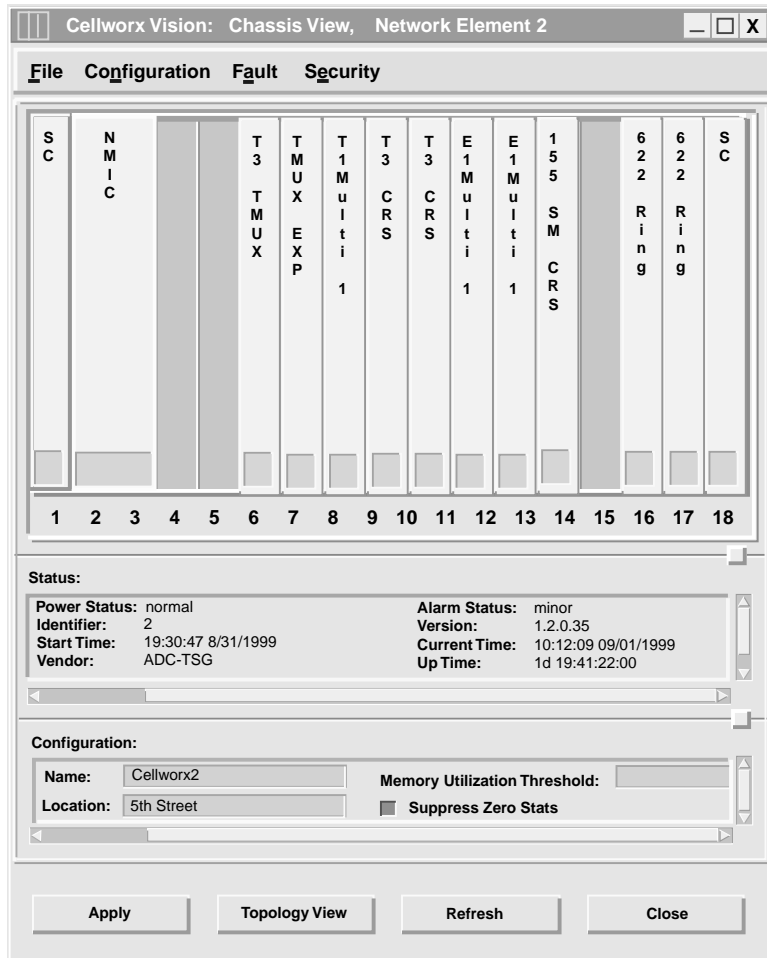

13455-B

**Figure 007-2. Shelf Level GUI Screen (example)**

7. The status of the shelf is displayed under the Status heading below the shelf. Use the slider bars to view the information provided if needed. The power status and alarm status are displayed for the shelf and should reflect the Icon alarm condition shown on the main GUI screen that brought you here.
8. Above this section in the card display are individual status indicators on each card. The indicators are at the bottom of each card and should be green for a normal condition, red for a critical/major alarm condition, or yellow for a minor alarm condition.
9. To retrieve the status of any card, double click on it using the left mouse button and a card level GUI screen will appear. Start with the card in the highest alarm severity (Critical). Refer to the following procedures for each card type selected.
 

• Retrieve the SC card status.	DLP-757
• Retrieve the 622 RIC card status.	DLP-759
• Retrieve the 155 CRS card status.	DLP-760
• Retrieve the 622 CRS card status.	DLP-796
• Retrieve the T3 CRS card status.	DLP-761
• Retrieve the T3 TMUX MULTI 1 status.	DLP-762
• Retrieve the 155 RIC card status.	DLP-763
• Retrieve the T1/E1 MULTI 1 card status.	DLP-764
• Retrieve the 2488 RIC card status.	DLP-779
• Retrieve the FT1 FRS card status.	DLP-788
• Retrieve the FE1 FRS card status.	DLP-789
• Retrieve the T3 CES card status.	DLP-793
10. Close the chassis view and return to the GUI main screen by selecting the *Close* button at the bottom of the window.

**Stop! You have completed this procedure.**

## RETRIEVE PERFORMANCE MONITORING STATISTICS

**Summary:** This procedure describes the steps required to successfully retrieve the performance monitoring statistics via the NMIC Graphical User Interface (GUI) for any interface installed within the Cellworx STN network. Performance information retrieved is on a per node and per port basis.

1. From the GUI main screen, select the *Performance* pull down menu and then *Monitoring* using the left mouse button or by hitting *Alt+P* and *Alt+M*. See Figure 008-1. User may also use the graph icon shown on the tool bar above the workspace.

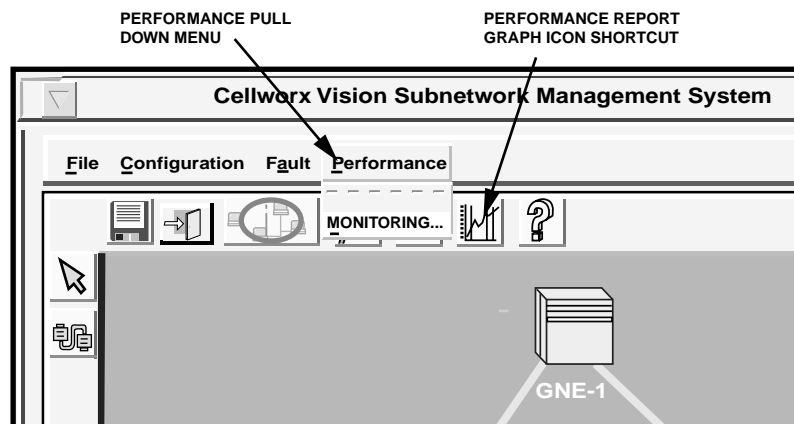

11744-C

**Figure 008-1. Cellworx Vision Performance Pull Down Menu**

2. The Cellworx Vision Performance Monitoring - Selection window appears as shown in Figure 008-2. In the upper left selection box, select a network element for PM statistics retrieval.

**NTP-008**  
**Page 2 of 2**

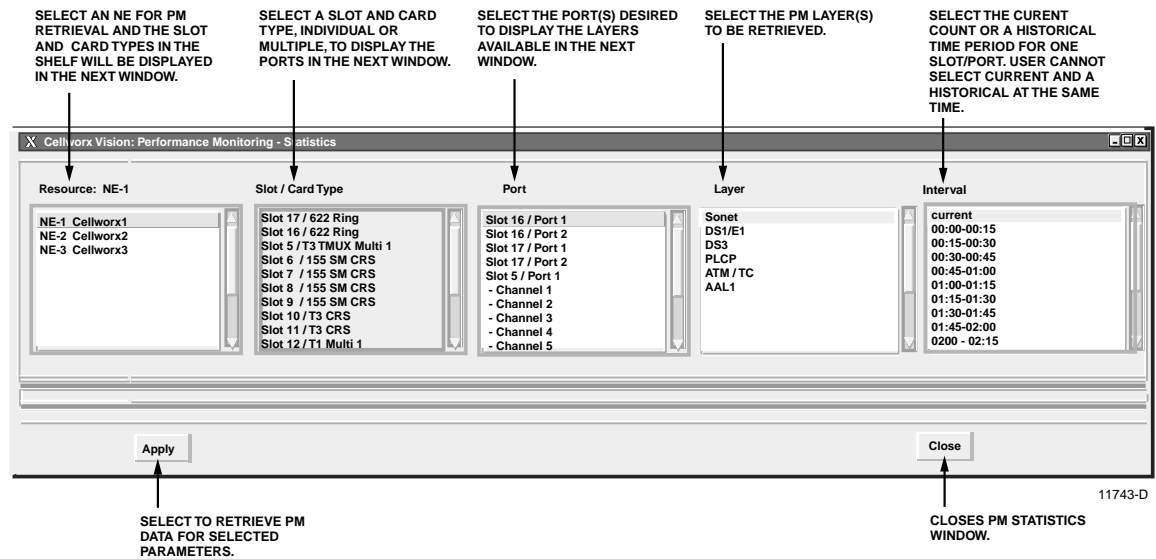

**Figure 008-2. Cellworx Vision Performance Monitoring - Selection Window**

3. Go to one of the following procedures according to the layer selected:

- Retrieve Optical Port Performance Monitoring Statistics DLP-726
- Retrieve T3 TMUX Performance Monitoring Statistics DLP-727
- Retrieve T3 CRS Port Performance Monitoring Statistics DLP-728
- Retrieve T1/E1 Multi 1 Port Performance Monitoring Statistics DLP-729
- Retrieve FT1 FRS Port Performance Monitoring Statistics DLP-732
- Retrieve FE1 FRS Port Performance Monitoring Statistics DLP-733
- Retrieve T3 CES Port Performance Monitoring Statistics DLP-794

**Stop! You have completed this procedure.**

**ADDING SERVICES TO A CELLWORX STN NODE**

**Summary:** This procedure outlines the steps involved for assigning card, port, and user level parameters for individual interface cards and configuring protection operation for grouped interface cards within each node. The cards must be physically equipped within a shelf before the slots can be configured via the software.

1. Verify the cards to be provisioned are physically equipped within the shelf by double clicking on the node to open a shelf level GUI display. Each card should have a green status indicator.
2. Refer to the Cellworx STN Installation manual for card installation procedures if cards are not currently equipped, otherwise continue. 1152693
3. To remove or install cards currently in the chassis, refer to: DLP-777
4. Set the configuration options for the following cards when equipped:
  - Set the E1 Multi 1 Card configuration. DLP-747
  - Set the 622 RIC card configuration DLP-751
  - Set the 155 CRS card configuration DLP-752
  - Set the 622 CRS card configuration DLP-797
  - Set the T3 CRS card ATM configuration DLP-753
  - Set the T3 TMUX Multi 1 card configuration. DLP-754
  - Set the T1 Multi 1 Card configuration. DLP-755
  - Set the 2488 RIC card configuration options. DLP-756
  - Set the 155 RIC configuration options. DLP-758
  - Set the FE1 FRS Card configuration. DLP-784
  - Set the FT1 FRS Card configuration. DLP-785
  - Set the T3 CES Card configuration DLP-792
5. Configure card protection groups if applicable for each group of interface cards. DLP-765
6. Close the card configuration window to return to the shelf display. Verify that the required cards are in-service by the green status indicator.
7. Perform acceptance tests on the new access cards when applicable. NTP-011

**Stop! You have completed this procedure.**

**NTP-010**  
**Page 1 of 1**

## **DELETE A CELLWORX STN NODE**

**Summary:** This procedure outlines the steps involved to remove a Cellworx STN ring node from an in-service ring network, or an expansion shelf from an in-service condition. This procedure enables the network administrator to change the network configuration when required. It may be necessary to remove a ring NE via software if the network is being uninstalled, or the equipment at a site is being moved to a new location, etc. Before removing a node from the network, all VP/VC connections to that node must be deleted.

### **DELETE A RING NODE FROM AN IN-SERVICE RING SYSTEM**

1. Launch the Cellworx Vision Graphical User Interface (GUI). DLP-705
2. Delete any VP/VC connections that are terminated at the node being removed from service. DLP-739
3. Delete the node via the GUI using one of the following procedures according to the type of node being removed:
  - Delete a Cellworx STN node. DLP-740
  - Delete a Cellworx STN EPS shelf. DLP-746

**Stop! You have completed this procedure.**

## **CONDUCT ACCEPTANCE TESTS ON A CELLWORX STN NODE**

**Summary:** This procedure lists the test that can be performed on a newly installed Cellworx STN node whether installed as a ring node or terminal node.

SONET Diagnostics	DLP-766
Initiate a Protection Switch	DLP-771
Perform Loopback Tests	DLP-772
Initiate a Card Reset	DLP-773
Execute an Alarm Cut Off (ACO)	DLP-776



**NTP-012**

Page 1 of 1

**PERFORM ROUTINE OR NON-ROUTINE MAINTENANCE**

**Summary:** This procedure lists procedures that can be followed to perform maintenance tasks on a Cellworx STN ring network that may or may not be considered routine. Non-routine maintenance may include installing new software versions on the NMIC, downloading new software to interface cards, forcing cards off-line for maintenance procedures, and troubleshooting alarms. Routine maintenance may include executing an Alarm Cut-Off (ACO), retrieving performance monitoring reports, retrieving inventory lists, or retrieving alarm reports.

**Graphical User Interface Procedures**

- |   |         |
|---|---------|
| 1. Force Network Discovery                                  | DLP-719 |
| 2. Launch the Cellworx Vision GUI from the X-Terminal       | DLP-705 |
| 3. NMIC System File Replication                             | DLP-722 |
| 4. NMIC Protection  | DLP-724 |
| 5. Perform Diagnostics on the optical cards                 | DLP-766 |
| 6. Retrieve Logs from the NMIC via FTP                      | DLP-741 |
| 7. Retrieve Compressed Logs from NMIC via FTP               | DLP-742 |
| 8. Select different software versions for a particular card | DLP-720 |
| 9. View Ring Resource Usage                                 | DLP-715 |
| 10. View Fiber Bandwidth Usage                              | DLP-716 |

**Stop! You have completed this procedure.**

## CREATING CONNECTIONS

**Summary:** This procedure outlines the steps required to create ATM Virtual Path Connections (VPC) and Virtual Channel Connections (VCC) through the Cellworx STN network. A VCC is an individual channel between two communicating systems. The VPC allows multicasting of several VCCs to ease routing between switches where multiple VCCs share a common path. The VPCs are a common requirement of WAN installations. The administrator should have acquired a work order defining the bandwidth requirements, service type, and Quality of Service (QoS) for each connection before proceeding.

1. Creating traffic contracts. DLP-709
2. Create an ATM VP or VC connection through the Cellworx STN system. DLP-708
3. Create an ATM VP Multicast Connection. DLP-787
4. Create an ATM Bundled VC Multicast Connection. DLP-790
5. Add a Leaf Endpoint to an In-Service Connection. DLP-791

**Stop! You have completed this procedure.**

**NTP-014**  
**Page 1 of 2****MONITORING THE NETWORK**

**Summary:** This procedure provides information that enables the Network Administrator to successfully monitor a Cellworx STN network via the Cellworx Vision Graphical User Interface (GUI). The information provided directs the user to pertinent sections and procedures within the User's manual. Brief functions and features of the software are provided as well as layout and monitoring suggestions, and troubleshooting directives.

**1. NETWORK LAYOUT VIEW**

- 1.1 The Cellworx Vision GUI allows the user to reposition NE icons on the screen for custom tailored displays of individual networks. Once NE icons are repositioned on the screen, the Save Icon Layout procedure should be performed to retain the new positions of the NEs, otherwise, the icons will return to the last saved positions on the screen the next time the GUI is launched.

DLP-736

**2. ICON ALARM INDICATIONS**

- 2.1 The NE icons displayed on the Cellworx Vision GUI provide at a glance alarm indications through color changes. If a node is operating within tolerances and thresholds set by the user (or default), the icon will appear green (normal operation). If a node has crossed a minor threshold or generated a minor alarm condition, the icon color changes to yellow. Similarly, a major alarm changes the icon to orange and a critical alarm changes the icon to red. If an icon appears blue in color, this indicates that the NMIC has lost communication with the node and the fiber connection between them may also change in color indicating a problem.

**3. DIRECTIVES****A. Alarms**

- 3.1 After determining a node is in alarm and the severity of the alarms, the user should retrieve an alarm report via the NMIC using NTP-007. This procedure describes the steps required to retrieve reports from the Cellworx Vision GUI, and establishing a craft session at a node, starting with the highest level of alarm (Critical, Major, then Minor), using the craft interface to retrieve NE level alarm reports. For quick reference, a list of all alarm types is provided in the Trouble Analysis Procedure at the end of this section.

## **B. Adding Services**

- 3.2 Slots within a shelf may have cards equipped but not in-service, or un-provisioned ports available on a card that is already in-service. This allows the administrator to assign bandwidth, ports, or connections on the network to customers as needs demand. When adding additional services, ports, etc., refer to: NTP-009
- 3.3 When establishing new ATM VP/VC connections to in-service cards and ports, refer to: NTP-013
- 3.4 When upgrading software releases or ring interfaces, refer to: NTP-016

## **4. HELP LINE**

- 4.1 For assistance in retrieving reports, troubleshooting alarms, warranty information, etc., the ADC Help Line is provided through the Cellworx Vision GUI software. To access this information, refer to: DLP-735

**NTP-015**  
**Page 1 of 2**

**ADMINISTRATIVE TASKS**

**Summary:** The following procedures are outlined to identify tasks that a system administrator would need to perform for user accounts, log files, and data collection on the Cellworx STN system.

- |  |         |
|--|---------|
| 1. Launch the Cellworx Vision GUI from the X-Terminal.   | DLP-705 |
| 2. View Connections  | DLP-710 |
| 3. Configure Service Provider Profile.   | DLP-714 |
| 4. View Ring Resource Usage  | DLP-715 |
| 5. View Fiber Bandwidth Usage  | DLP-716 |
| 6. Retrieve NE information.  | DLP-721 |
| 7. NMIC System File Replication  | DLP-722 |
| 8. NMIC Protection Restoration   | DLP-725 |
| 9. Reflash Boot Image  | DLP-744 |
| 10. Save the Current System Database, Reboot the Database Using a Saved Copy, or Reboot the Database Using a Default Database. | DLP-745 |
| 11. Set Craft User Configuration   | DLP-768 |
| 12. Set Craft Menu Configuration   | DLP-769 |
| 13. Hardware Inventory   | DLP-770 |
| 14. Finding and Changing NMIC IP Address   | DLP-774 |
| 15. Add or Change an SNMP Trap Host on the NMIC  | DLP-775 |
| 16. Log off of Cellworx STN GUI.   | DLP-711 |
| 17. Remove and/or Replace Cellworx cards   | DLP-777 |
| 18. Ending a GUI Session Following an Abnormal Session Ending.   | DLP-778 |
| 20. Removing the NMIC from the Shelf   | DLP-781 |
| 21. FTP Database Files off of NMIC   | DLP-782 |

- |  |         |
|--|---------|
| 22. Add/Delete GUI Users or Change GUI User Level Security | DLP-783 |
| 23. Change Configuration/Test on an Existing Connection    | DLP-723 |
| 24. Retrieve Network Data Collection (NDC) Statistics      | DLP-730 |

**NTP-016**

Page 1 of 2

**CELLWORX UGRADE PROCEDURES**

**Summary:** The following procedures deal with Cellworx STN system upgrades. A ring upgrade takes a ring from a lower bandwidth level (OC3c or OC12c) to a higher bandwidth level (OC12c or OC48c). The following levels of ring upgrade are allowed:

- OC3c ring to an OC12c or OC48c ring
- OC12c ring to an OC48c ring

A ring upgrade is only supported if the user has purchased the standard feature package on 3.0 release software. The ring upgrade may be performed with the 2.0 to 3.0 major software upgrade or at any time after a Cellworx 3.0 ring has been successfully installed. The ring upgrade procedure may only be performed by the first privileged user to start the Cellworx GUI.

**SOFTWARE UPGRADE**

- |   |         |
|---|---------|
| 1. Launch the Cellworx Vision GUI from the X-Terminal.  | DLP-705 |
| 2. Check the system for any existing alarms beforehand to ensure no new problems are introduced after the upgrade. Refer to the Display Network Alarm Summary procedure.  | DLP-713 |
| 3. Retrieve the Shelf Controller Card (SCC) card status for each SC in the system. An SCC must be present in slot 1 of every shelf. The SCC in slot 1 does not have to be active but if only one SCC is present in any shelf, it must be in slot 1. | DLP-757 |
| 4. Log off of Cellworx STN GUI.   | DLP-711 |
| 5. Perform the Phase 3.0 to 3.1 Software Upgrade Procedure  | DLP-795 |
| 6. Display the network alarm summary to determine if any new alarms exist on the system.  | DLP-713 |

**Stop! You have completed this procedure.**

**NTP-016****Page 2 of 2****RING UPGRADE**

When changing an existing ring network to a higher bandwidth (OC3c to OC12c/OC48c, OC12c to OC48c), the following procedures should be followed.

1. Launch the Cellworx Vision GUI from the X-Terminal. DLP-705
2. If desired, the user may record the ring bandwidth usage before and after the interface upgrade to view the drop in resource usage. Refer to the View Ring Resource Usage procedure. DLP-715
3. Check the system for any existing alarms before the upgrade to ensure no new problems are introduced following the upgrade. Refer to the Display Network Alarm Summary procedure. DLP-713
4. Perform the Ring Upgrade Procedure DLP-731
5. Check the configuration on the new optical interface cards and make any changes as needed using the following procedures:
  - Set the 2488 RIC card configuration options. DLP-756
  - Set the 622 RIC card configuration DLP-751
6. Display the network alarm summary to determine if any new alarms exist on the system. DLP-713
7. Check the status of the new interface cards using the following procedures to ensure they are operating properly:
  - Retrieve the 622 RIC card status. DLP-759
  - Retrieve the 2488 RIC card status. DLP-779
8. If desired, perform diagnostics on the new optical cards. DLP-766



## POWER UP A CELLWORX STN NODE

**Summary:** This procedure provides instructions for verifying the source  $-48$  Vdc power supply.

1. Turn on the power source that will supply power to the system.
2. Use a multi-tester to measure the DC voltage at the source. When testing, place the positive probe on the  $-48$  V terminal and the negative probe on the COM or RTN terminal.
3. The measured voltage must be between  $-42.5$  Vdc and  $-56.5$  Vdc at the specified point. Was voltage within range specified? Note the polarity.

If **No**, proceed to step 4.

If **Yes**, continue with step 5.

4. The problem is in the power supply wiring or in the  $-48$  Vdc power supply. Isolate the problem using local troubleshooting practices and correct as required before installing power to the system. Repeat procedure after correcting problem.
5. Install fuses or engage the circuit breakers that supply power to the shelf. The front access cards should illuminate. This can be verified by observing the shelf alarm indicator on the front door panel. This will only light up if the SC cards are installed and an alarm is present. Refer to Figure 700-1.

**Stop! You have completed this procedure.**

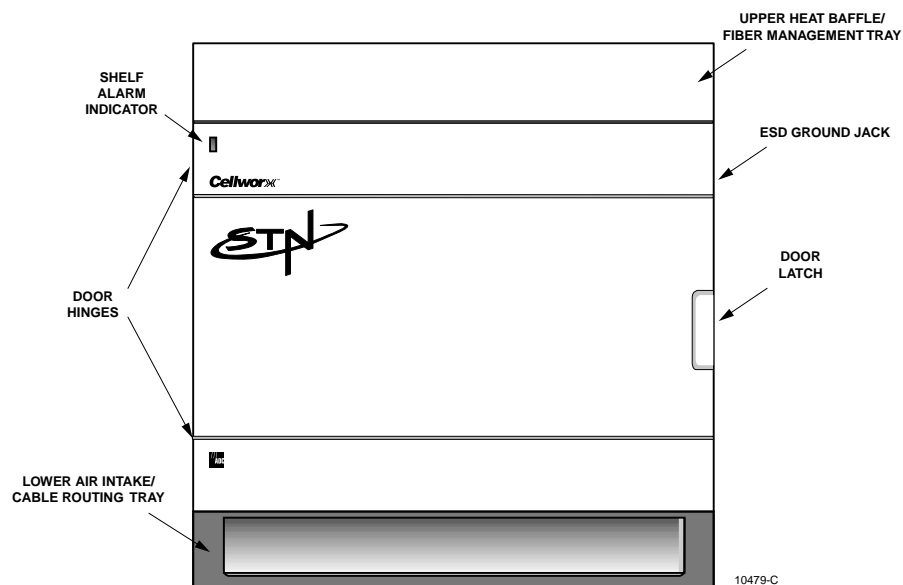

Figure 700-1. Cellworx STN Component Identification

## DLP-701

Page 1 of 10

## CONNECT FIBERS TO OPTICAL CARDS

**Summary:** This procedure describes the processes required to properly connect the inbound and outbound fiber optic cables to the correct ports on the optical cards. The optical connector configurations may vary from SC, ST, or FC fiber connectors, dependent upon the type of equipment ordered. Optical cards include the 2488, 622, and 155 RICs and the 155 SM/MM CRS cards. Note that on the 155 SM/MM CRS cards, there are two ports that may be utilized. If ordered, fiber connector adapters may be changed out on the RIC and 155 SM/MM CRS cards. The 155 MM card does not have a modular adapter.



**Danger:** *Do not look into the ends of optical fibers. Exposure to invisible LASER radiation may cause serious retinal damage or even blindness. Verify the optical source is disabled through the use of an optical power meter before handling optical fibers.*



**Caution:** *Use caution when routing wires and cables. Avoid severe bending and routing over sharp edges. Use grommet material when possible to avoid wear on cable insulation.*



**Caution:** *Allow sufficient fiber length to permit routing without severe bends. Fibers may be permanently damaged, or signal degradation may be experienced if fibers are bent or curved to a radius of less than 1.5 inches (3.81 cm).*



**Caution:** *Modules can be damaged by electrostatic discharge. Before handling any modules connect your wrist to an equipment ground using an approved anti-static wrist strap. Ensure that all uninstalled modules are stored in anti-static packing material. When working with modules, always place the module on an electrically grounded approved anti-static mat.*



**Caution:** *Using excessive force when seating cards and modules into the backplane may result in physical damage to the backplane pins or module connectors, and if power is applied, may result in serious electrical damage to both the modules or the backplane.*

## A. Fiber Routing

1. Check site plans to determine the fiber connection required. The RIC cards and 155 CRS SM/MM optical cards have modular adapters that can be changed to meet customer applications for either FC, SC, or ST type connectors. These adapters must be ordered separately if changes are required. The 155 CRS MM cards will be equipped per customer requirements from the factory as should the RIC and 155 CRS SM cards. Refer to Figure 701-1 to identify fiber connector types.
2. Tag and identify the optical fibers from the source (fiber distribution panel, etc.) before routing them to the Cellworx STN shelf (ex. 155/622, Clockwise/Counterclockwise, Slot no., In/Out, rack no., etc.)

3. Route the fiber cables to the Cellworx STN rack and to either upper side of the fiber management tray. For management purposes, it is recommended that the receive fibers are routed across one direction and the transmit fibers across the other direction. Refer to the example shown in Figure 701-2.
4. Using the fiber routing flanges, dress the fibers to the respective card slots per work order. Keep in mind the direction of traffic flow for the fibers. The slots designated for RIC interfaces or 155 CRS expansion shelf interfaces are slots 16 and 17. Slot 16 TX port will connect to the next node slot 16 RX port, continuing around the ring until all slot 16 cards are connected. Slot 17 TX port will connect to the next node slot 17 RX port until all slot 17 cards are fibered together around the ring. Refer to Figure 701-3 for fiber convention.
5. Leave enough slack in the fibers to enable them to dangle about six inches down the front of the shelf as shown in Figure 701-4. For 2488 RIC cards leave an additional four inches. Dress excess fiber per local practices. Lay the fibers on the fiber management tray so they will not interfere with card installation.
6. Route the remaining fibers to the respective 155 CRS equipped slots per work order. Keep in mind the slot numbers, matching them with the tagged fibers.
7. Dress the fiber cables in along the rack using panduct or similar routing devices per customer applications.

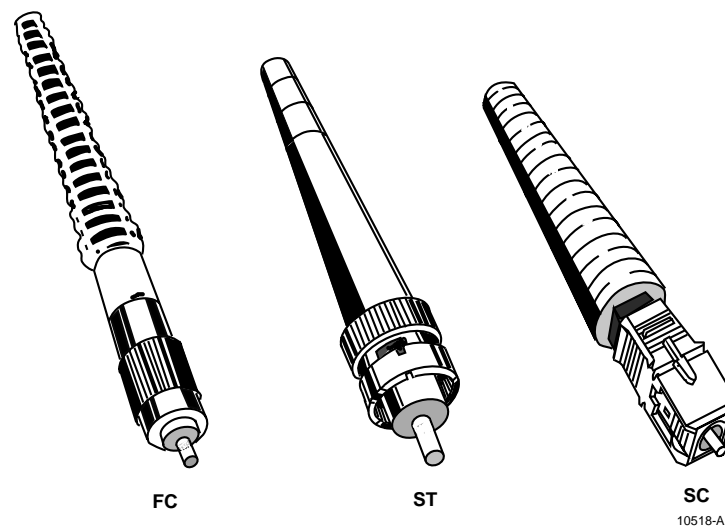

Figure 701-1. Optical Connector Identification

DLP-701  
Page 3 of 10

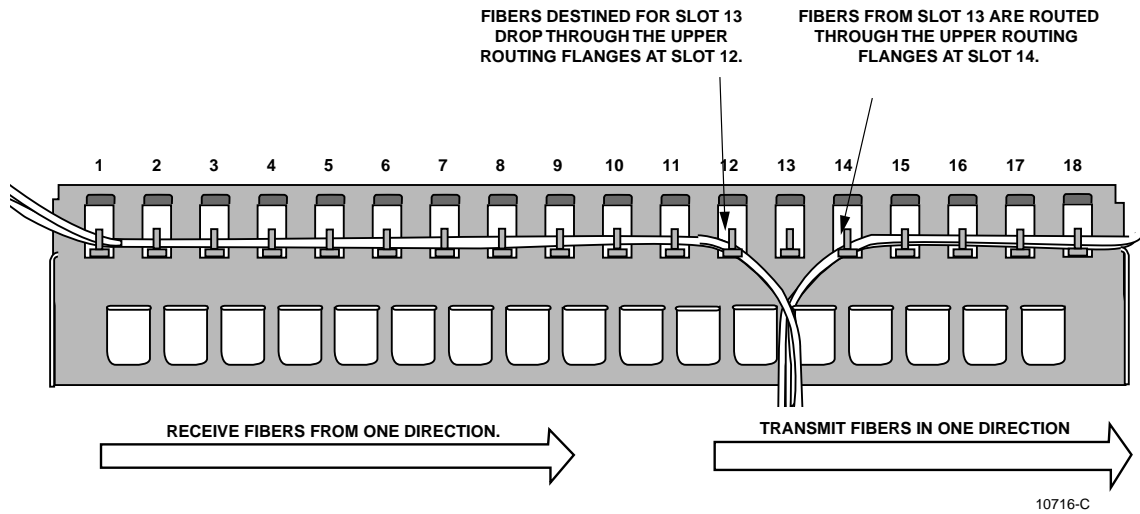

Figure 701-2. Routing Fiber Across the Fiber Management Panel

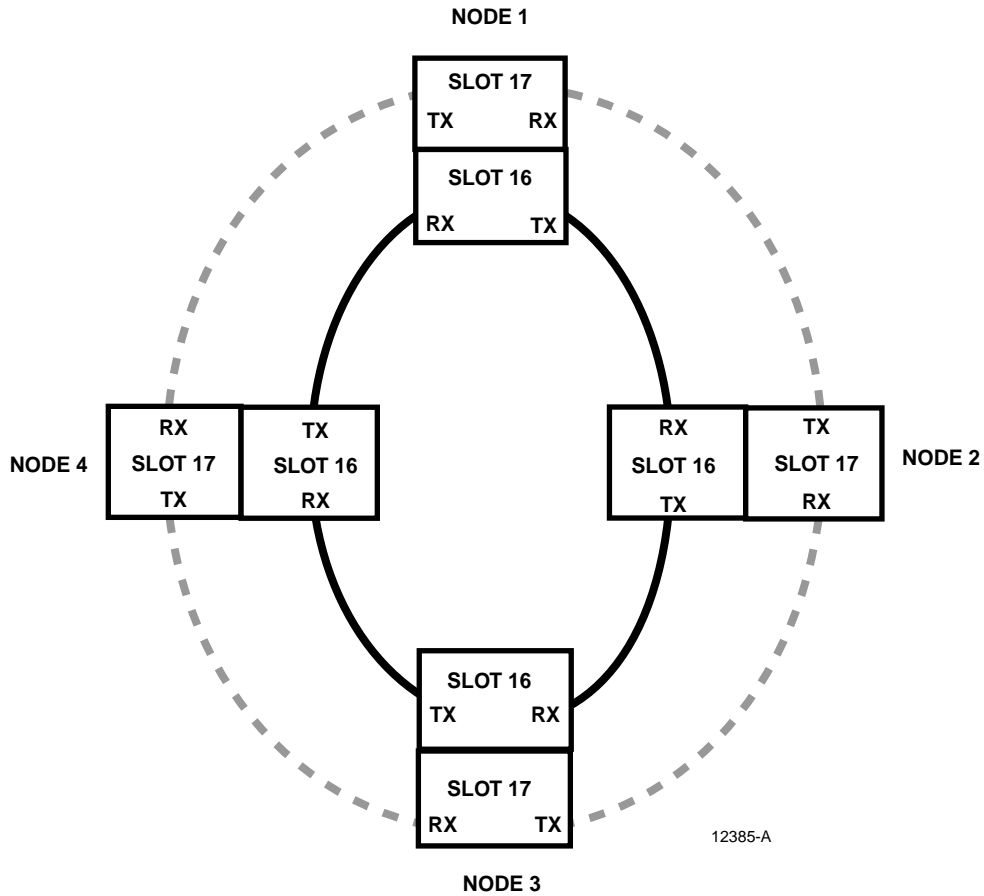

Figure 701-3. 622 RIC Fibering Convention

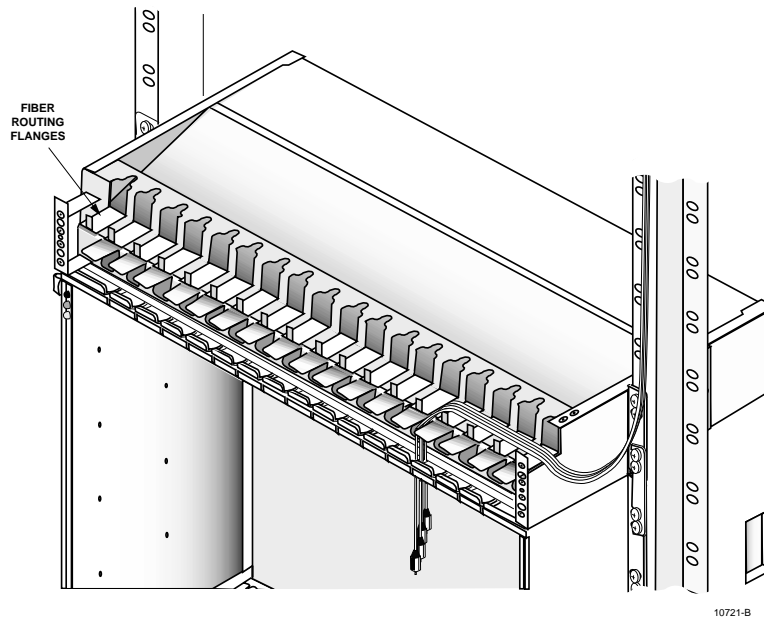

Figure 701-4. Fiber Routing

## B. Fiber Connection

► **Note: DO NOT LOOK INTO THE ENDS OF ANY FIBER OPTIC CABLES.**

8. If the cards are fully seated into the Cellworx STN backplane, disengage them by pulling back the ejector ears on the upper and lower ends of the card faceplate. See Figure 701-5. Back the card partially out just enough to expose the fiber connections as shown in Figure 701-6. Be careful not to pull the card out too far allowing it to dislodge from the shelf and fall to the floor.
9. Clean the fiber connectors per the instructions provided in section C of this procedure.
10. Connect the fibers to the optical connectors using Figure 701-6 as reference for RIC cards, and Figure 701-7 for 155 SM/MM CRS cards, noting the inbound and outbound directions of the fibers.
11. Once the fibers are connected, route them up through the fiber clip equipped at the top of the faceplate as shown in Figure 701-6 or 701-7. The fiber clip is identified in Figure 701-8.
12. Seat the card into the backplane by sliding it into the card cage until the ejector ears catch the shelf trough. Fully seat the card by pressing the ejector ears towards the faceplate until they lock into place. Do not force the cards into the backplane. **If excessive resistance is felt, remove the card and check for obstructions and proper alignment in card guides.** Once card is seated, give a firm push to insure good contact with the backplane.

**DLP-701**

Page 5 of 10

13. If power is applied and the database already exists on the NMIC, the optical card will boot. Once completed booting, the Port LED should turn green indicating it is receiving a good input signal. If the LED remains red, it indicates a Loss of Signal is present. In this case, go back to step 3 and recheck the input and output connections of the fibers. If they are correct, check the far end source. Determine and fix the problem before continuing.
14. If an optical power meter indicates a signal is present on the fiber, and it meets the input signal specification of the card, clean the module fiber connector to ensure there is no debris on the fiber itself. If the card still fails to acknowledge the input signal, it may be defective. Verify the inbound fiber signal using another optical card. Refer to the Apps and Engineering Phase 3.1 manual listed in the preface of this document for specifications.

**C. Cleaning and Mating Instructions for Fiber Optic Connectors and Adapters**

**Note:** Cleanliness will affect the performance of an optical fiber system. Perform the following procedures prior to installation. Clean all connectors, adapters, and attenuators before making any connections. Check local practices for approved cleaning methods and materials. The following cleaning materials are recommended and may form part of your cleaning kit:

- Lint-free laboratory wipes
- Isopropyl alcohol in pressurized dispenser
- Lint-free adapter cleaning tips
- Clean, dry, oil-free compressed air
- Fiber cleaning reel
- Fiber scope

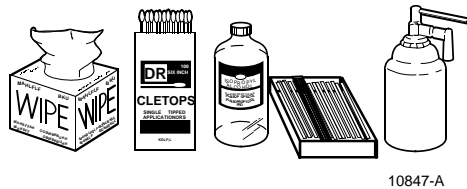

**Warning:** Handle, use, and dispose of chemicals in accordance with manufacturer's instructions.

- ◆ **Note:** When using canned compressed air, clear the nozzle with a short air blast before blowing any parts clean. *Do not shake the compressed air can.* Keep the can level while using to prevent liquid in the can from entering the air stream.
- ◆ **Note:** the use of these cleaning products does not guarantee a clean connector. A fiber scope should be used to ensure that the connector tip is lint free.

**CLEANING****Connectors/Terminators**

- ◆ **Note:** If using a fiber cleaning reel, follow the instructions generally included on the swiper box to advance the reel, twist the fiber end, and swipe across the track. Otherwise, use the following procedure.

15. Fold a clean, new wipe into a 2" by 2" square pad.

16. Moisten, but do not saturate, the pad with alcohol making a spot approximately  $\frac{1}{2}$ " in diameter.
  - ◆ **Note:** Alcohol should only be used when connector is really dirty. A fiber cleaning reel is always best. Use a cleaning reel even after alcohol to remove residue. Do not consume isopropyl alcohol at anytime.
17. Press the ferrule end face into a wet spot on the wipe. Using force, twist the ferrule so that a hard wiping action takes place. Repeat twice, using a clean alcohol-moistened area each time.
18. Press the ferrule end face into a dry spot on the wipe. Using force, twist the ferrule so that a hard wiping action takes place.
19. Discard the used pad.

#### Attenuators

20. For an exposed ferrule (in-line type), see connector cleaning procedure; blow the other end dry with clean compressed air.
21. Clean bulkhead attenuators *only* by blowing with clean compressed air.

#### Adapters

22. Moisten one end of a lint free adapter cleaning tips with alcohol.
23. Remove excess alcohol from the adapter cleaning tips with a clean wipe.
24. Insert the moistened adapter cleaning tips into either end of the adapter and scrub in and out so that the inside surface of the adapter is wiped by the pipe cleaner. Repeat this step for the opposite end.
25. Insert the dry end of the adapter cleaning tips into either end of the adapter to remove any residual alcohol. For oversized adapters (biconic), stir the adapter cleaning tips for better surface contact. Repeat this step for the opposite end.
26. Blow the adapter dry with clean compressed air.

#### MATING

##### FC

27. Insert the ferrule tip into the adapter.

## DLP-701

Page 7 of 10

28. For D4 and FC types, align the key with the slot in the adapter.
29. Push the connector into the adapter until the coupling nut reaches the adapter housing.
30. Screw the coupling nut clockwise onto the adapter to complete the connection.

## ST<sup>®</sup>

31. Align the ferrule hub key with the slot in the adapter.
32. Insert the connector into the adapter until the coupling nut reaches the adapter housing.
33. Align the bayonet slots on the coupling nut with the pins on the outside of the adapter.
34. Push the coupling nut onto the adapter while rotating the coupler nut clockwise to lock the bayonet and secure the connection.

## SC

35. For the SC, align the housing key with the slot in the adapter.
36. Push the connector into the adapter until a click is heard/felt indicating the latching system is engaged. When fully engaged, the white stripes on the sides of the SC housing should be hidden inside the adapter.

**Stop! You have completed this procedure.**



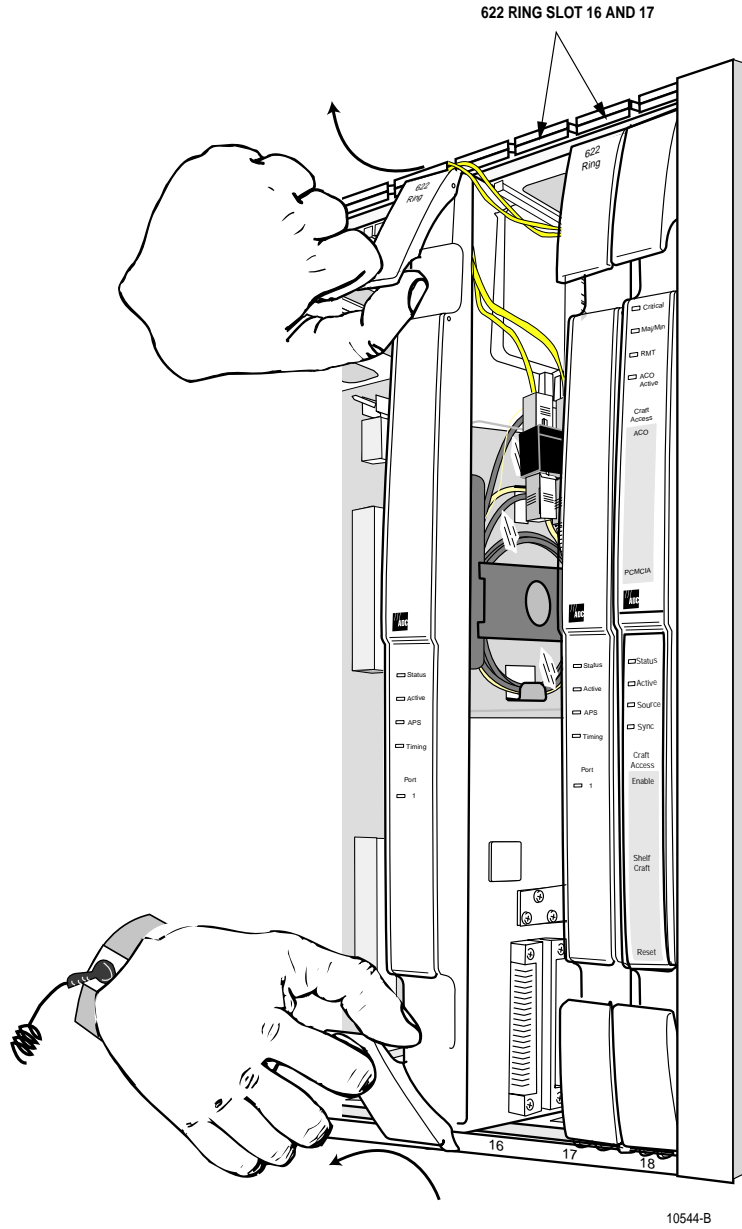

Figure 701-5. Disengaging the Optical Module

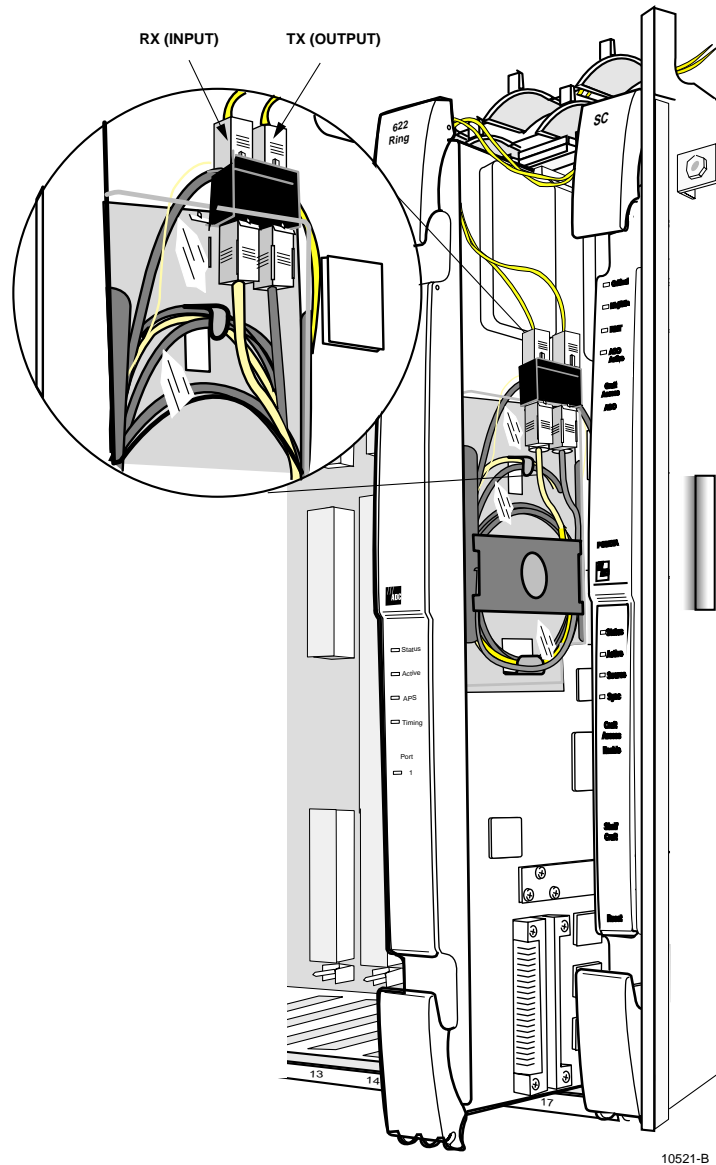

Figure 701-6. Fiber Connections on a Cellworx 622 RIC Card

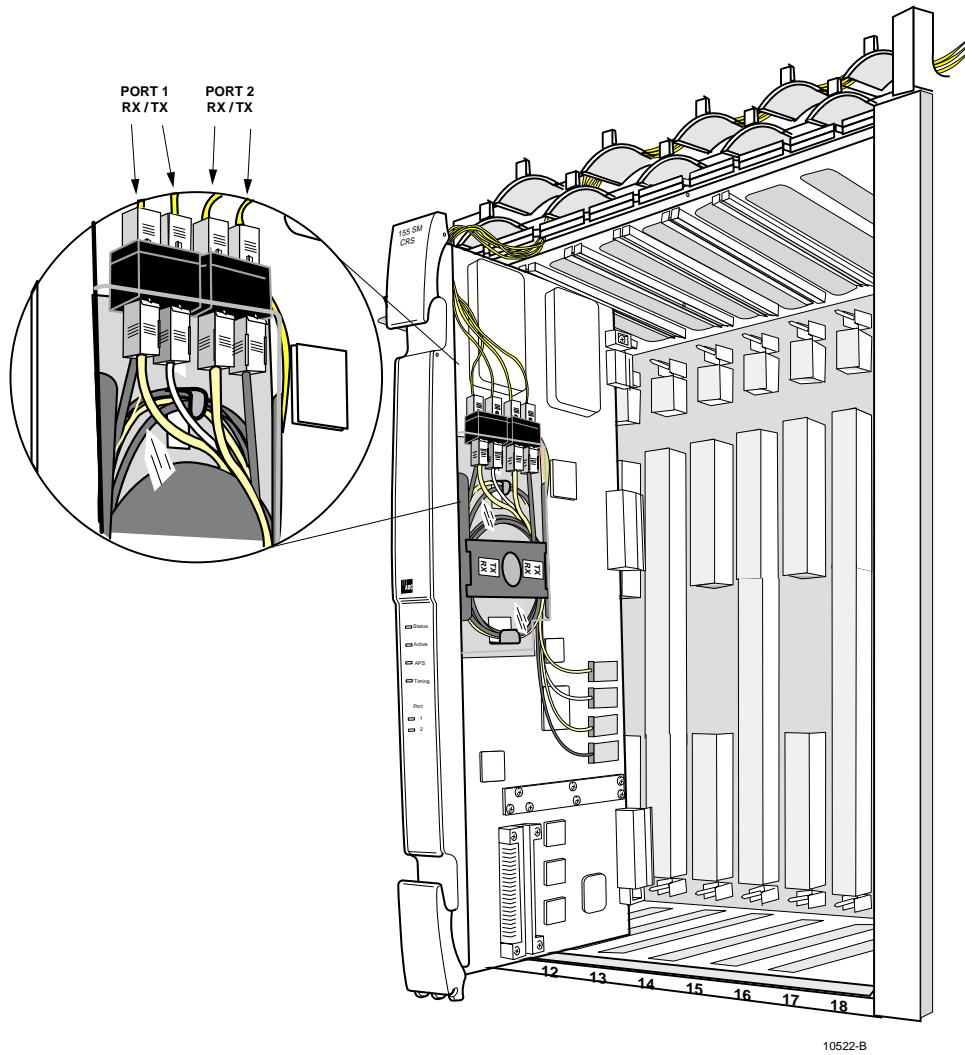

Figure 701-7. Fiber Connectors on an 155 SM/MM CRS Card



Figure 701-8. Faceplate Fiber Clip on Optical Card (622 shown)

**DLP-702**

Page 1 of 5

**CONNECT VT100 TERMINAL TO NMIC RS232 PORT  
AND MODIFY NMIC IP ADDRESS**

**Summary:** This procedure describes making the connection from a VT100 terminal (or PC with VT emulating software) to the NMIC RS232 port, and setting the IP address. The craft connector wiring convention is also covered in this DLP. The NMIC craft port is only used during initial setup of the NMIC to initialize the environment and enable Graphical User Interface (GUI) or Simple Network Management Protocol (SNMP) capabilities from a Network Management System (NMS). The IP is the target address for NMS access to the system information. The IP address should be assigned by the Network Engineer and programmed into the Cellworx STN by the user.

The NMICs are a PowerPC workstation running Linux software and are shipped with a temporary physical IP address of 155.226.39.28 which may be used to initially communicate with the NMIC. The USER however must modify the IP address before using the Cellworx system. A brief overview of the IP Address implementation in Cellworx, the process of changing the IP address, and the process of displaying the Cellworx Graphical User Interface is described in this procedure. If the NMIC status LED is blinking red, the network information has not yet been configured.

If the IP addresses are not listed in the installation work order or project book, consult with your company's corporate Networking Administration for policies and acquisition of suitable IP addresses. Companies can create their own IP networks without any relationship to the public IP network. This may be desirable since the STN would be set on a private IP network and not on the public IP network. If these IP addresses are never intended to communicate with the outside world, the assignment of an IP address is arbitrary. For sanity reasons, pick an address using the following blocks that are specified as "internal network".

- 10.0.0.0 to 10.255.255.255
- 172.16.0.0 to 172.31.255.255
- 192.168.0.0 to 192.168.255.255, (except 192.168.88.0 and 192.168.90.0 which are internal to the ring system. Refer to the /etc/hosts file for listings)

► **Note:** This procedure assumes the NMIC is installed in the correct slots within the GNE shelf and has power applied.



**Caution:** *Modules can be damaged by static electrical discharge. Before handling any modules connect your wrist to an equipment ground using an approved anti-static wrist strap. Ensure that all un-installed modules are stored in anti-static packing material. When working with modules, always place the module on an electrically grounded approved anti-static mat.*

1. Obtain access to a VT100 terminal, or a PC with VT emulation software, at GNE location. Verify the connector pin out per the NMIC Craft port pin out information shown in Figure 702-1.

2. Open the lower hinged faceplate of the working NMIC card in slots 2-3, as shown in Figure 702-2, and locate the DB9 craft connector.
3. Plug the craft cable into the NMIC card craft port and hit return to get the login prompt.

## 1. MODIFYING THE NMIC IP ADDRESS

4. The NMIC must have its IP address configured to a valid IP address compatible with the local network. This will enable the Graphical User Interface (GUI) to be displayed either on a networked PC operating as an X-server or on a workstation. A single NMIC requires the use of a unique IP address and an additional IP address shared by both NMICs, referred to as the Active IP address. A pair of NMICs (working and protect) require the use of 3 IP addresses. The Active IP address must be configured the same on both NMICs to allow it to float between the two depending on which one is active. The active NMIC will respond to both its own IP address and the Active IP address. The stand-by NMIC will only respond to its own IP address. By using this floating Active IP address the user can communicate with the Cellworx system using a single IP address regardless of which NMIC is active. Refer to Table 702-1 for details on the required IP addresses on a single NMIC, and Table 702-2 for a working /protect NMIC. If a NMIC is replaced, the replacement must match the setup of the one being replaced.

Table 702-1. NMIC IP Address Requirements

SINGLE NMIC	IP ADDRESS A	IP ADDRESS B	ACTIVE IP ADDRESS
NMIC (NMIC A)	X		X

Table 702-2. NMIC IP Address Requirements

WORKING/PROTECT NMIC	IP ADDRESS A	IP ADDRESS B	ACTIVE IP ADDRESS
NMIC A	X		X
NMIC B		X	X

## 2. CHANGING THE IP ADDRESS OF A NMIC:

5. To change either the NMIC IP address or the Active IP address for that NMIC, login to it either via telnet or through the RS-232 front panel console port. Upon initial shipment the user should perform login via the “root” userid. There is no password.
6. The user will see a [root@nmicx (x = 2 or 4)] prompt. The status LED on the NMIC should turn amber before continuing. This may take two to three minutes. Execute a “killall -9 psm” command on the NMIC to stop the NMIC Cellworx processes. If the NMIC has already reached a “double green” LED condition, execute a “killall psm nmic” command.

## DLP-702

Page 3 of 5

7. The last two text lines must be removed from the /etc/hosts file. This step has already been performed before NMIC shipment. If this is the first time the IP address is being changed, skip this entire step and proceed to step 8. If the IP address has been changed previously, continue with the following steps.
  - a. On the NMIC, type “cd /etc” to go to the etc directory.
  - b. Make a copy of the hosts file for backup by typing “cp hosts hosts.backup”.
  - c. Type in “export TERM=vt100”.
  - d. Using the vi editor on the NMIC edit the hosts file. To activate the vi editor with this file type “vi hosts”.
  - e. In the editor, go to the bottom of the file by holding down the shift key and typing g (shift+g).
  - f. The last two text lines of this file must be deleted. The keyword to look for is “EactiveNMIC” in the last line. The two lines will look similar to the following:  

```
155.226.39.28 WS03928  
  
155.226.39.27 EactiveNmic
```
  - g. To delete these last two lines, and type “2dd”.
  - h. Save the file by typing “:x” in the editor followed by an enter.
8. Type “cd /sbin” to go to the sbin directory.

◆ **Note:** : The user should make a backup of the /etc/hosts if not already done.

9. Type “./cw\_netcfg” to execute the cw\_netcfg script. This script will prompt the user to enter various IP addresses and IP masks to be changed as defined in Table 702-3.

◆ **Note:** DO NOT USE THE BACKSPACE KEY TO EDIT ON THE COMMAND LINE WHEN ENTERING INFORMATION. Doing so may insert non-printable characters in the IP addresses being entered resulting in a bad configuration. Use the Ctrl+C exit out and restart to correct mistakes.

Table 702-3. NMIC IP Addresses and IP Masks Definitions

Command Line	DEFINITION
IP ADDRESS	The IP Address for the NMIC. Must be unique for each NMIC.
HOSTNAME	The name used for the IP address.
ACTIVE IP	The Active IP address. Must be the same for a working/protect NMIC pair.
NETMASK	Subnet mask in use. Typically this is 255.255.255.0 for a class C address.
BROADCAST ADDRESS	The IP address for broadcasts on a subnet. Typically this is X.X.X.255 where X.X.X is the first three numbers for the valid NMIC IP address.
NETWORK IP ADDRESS	The base address for the subnet. Typically this is X.X.X.0 where X.X.X is the first three numbers of the valid NMIC IP address.
GATEWAY IP	IP address of the gateway for the subnet.

10. Enter all information, do not leave anything blank. The gateway may be left blank depending on configuration. There are no default settings. At the end of the script the user will be prompted to change the root password. If the password does not need to be changed just enter the current one; otherwise enter a new root password.

◆ **Note:** If you make a mistake, you may type CTRL-C and restart at step 9.

11. Reboot the NMIC by typing “shutdown –r now” on the NMIC terminal command line. The NMIC will reboot and the new IP addresses will take effect.

### 3. BRINGING UP THE CELLWORX GRAPHICAL USER INTERFACE.

◆ **Note:** A user can display the Cellworx Graphical User Interface on either a PC or a workstation. To display the Cellworx Graphical User Interface on a PC, the user must have an X window emulation package, such as Exceed, installed and activated.

12. Set up the personal computer sub-network to match the NMIC sub-network IP address structure and then reboot the computer.
13. Verify the IP address set on the NMIC using a “ping” command to both NMIC IP addresses by typing: ping xxx.xxx.xxx.xxx (xxx = 255 or less) to ensure both EIMs are operational. The pings should display on the screen. If the ping delays returning a response and times out, check Ethernet connection cabling and also verify the correct NMIC IP address was entered.
14. Establish a Telnet session to the active NMIC using the customer defined IP address set in DLP-702 (or set up a connection name on X-Terminal for that NMIC and select it.)
15. Logon to the NMIC.

DLP-702  
Page 5 of 5

16. The user needs to configure the NMIC to launch the display to the proper machine. To do this enter “export DISPLAY=X.X.X.X:0.0” on the NMIC command line. Here X.X.X.X is the valid IP address of the PC or workstation that is to receive the display.
17. Type “CellworxVision” at the NMIC prompt to launch the GUI. The display should appear on the designated PC or workstation. If the NMIC gives a message indicating it is unable to launch the display make sure the workstation in use is configured to accept displays from other machines. This is done by typing “xhost +” on the command line of the workstation (not the NMIC).

**Stop! You have completed this procedure.**

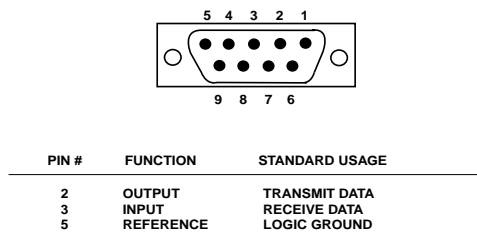

10564-B

Figure 702-1. NMIC Craft Port Pin Out Information

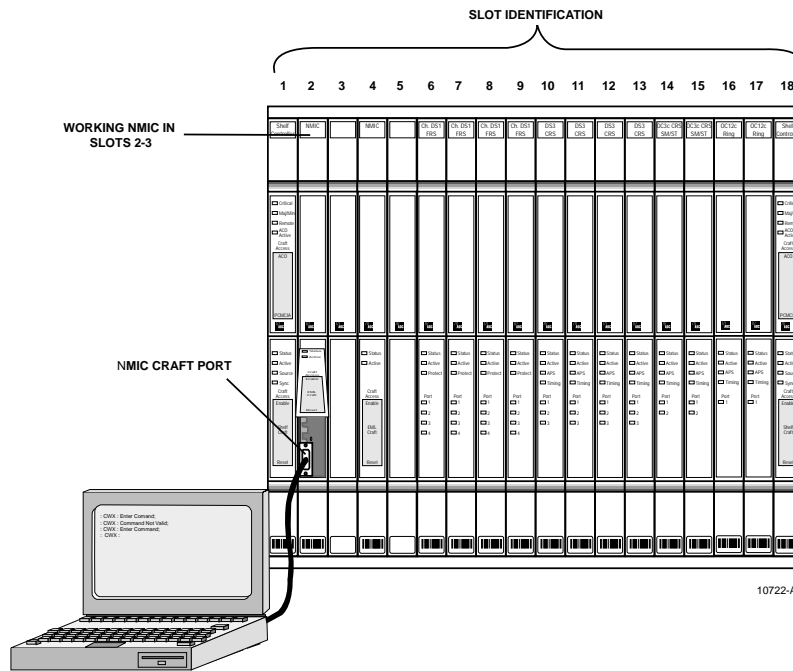

10722-A

Figure 702-2. NMIC Craft Port Connection



## LOGON TO REMOTE NODE CRAFT SESSION VIA TELNET FROM GUI

**Summary:** This procedure instructs the operator in the steps required to logon to an NE through the craft session from the NMIC Cellworx Vision GUI. Once logged onto the NE craft screen, the operator can provision all cards, ports, and alarms for that shelf. The provisioning information is set on the shelf controllers and backed up onto the NMIC immediately following the change. Prerequisites to this procedure requires that the operator must first have launched the GUI that controls the node targeted for craft interface session, and the node must have been discovered and is visible to the NMIC.

1. To establish a craft session to a node from the GUI, select the Direct Selection tool (arrow) on the left tool bar using the left mouse button. Next select the targeted NE and then hit the right mouse button. A pop-up menu appears. See Figure 703-1. Select **Craft Interface**.
2. The targeted node responds with a logon screen prompting the operator for a user name and password. See Figure 703-2. If this is the first time the node had been logged onto, the default name and password should be “cellworx” and “cellworx#1”. If this is an existing network, the defaults should have been deleted and unique name and password entered. If you are not sure of the new user name and password for this node, check with your network administrator.
3. The Cellworx main menu should now be displayed resembling the example shown in Figure 703-3.

**Stop! You have completed this procedure.**

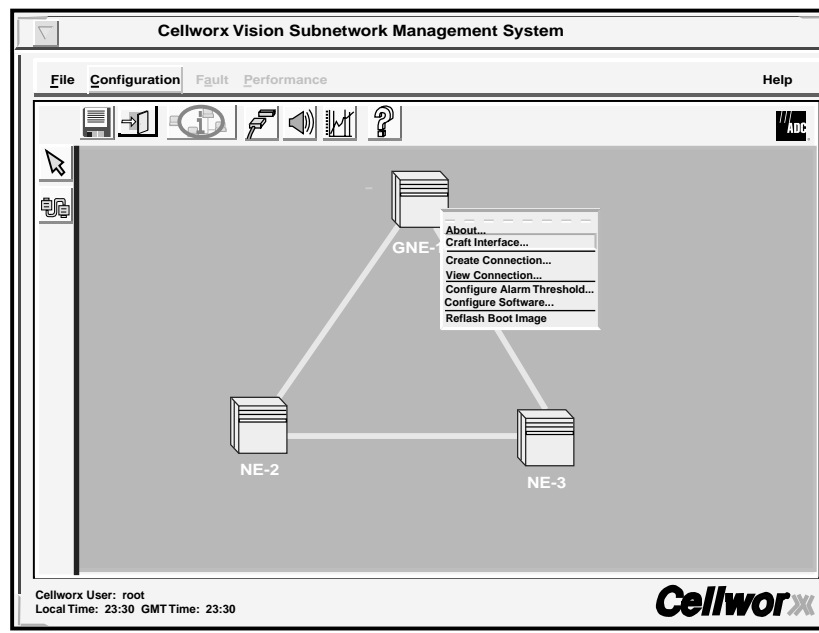
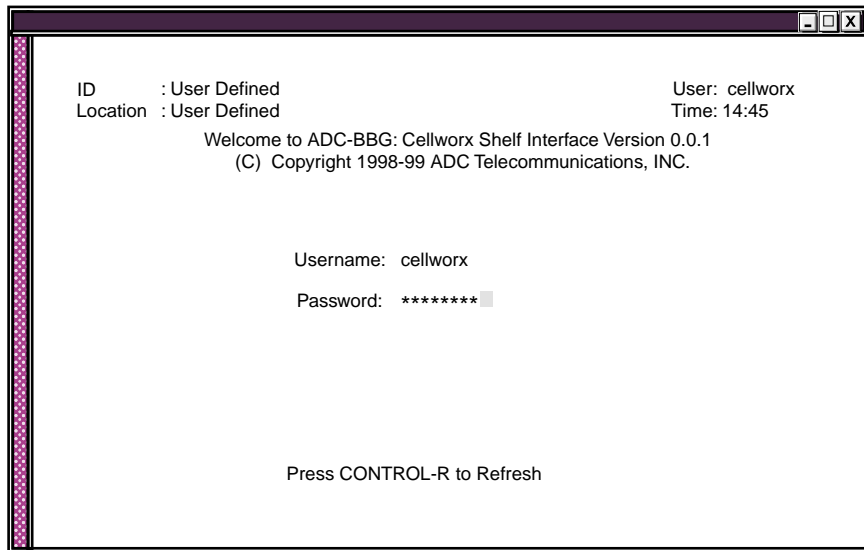

Figure 703-1. GUI Remote Craft Logon Pop-up Window

DLP-703  
Page 2 of 2



10644-C

Figure 703-2. Remote Craft Logon Screen

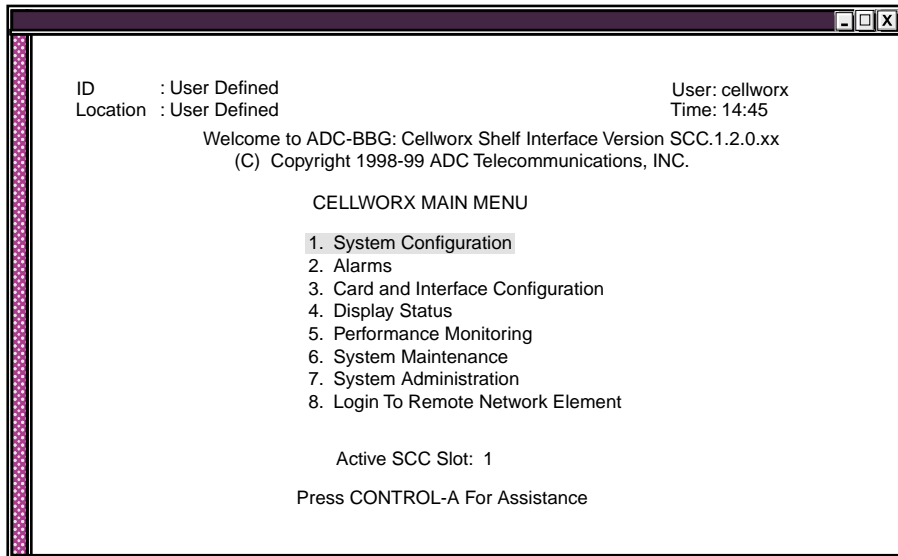

10607-F

Figure 703-3. Cellworx STN Node Craft Screen Main Menu

## CONNECT NMS OR X-TERMINAL ETHERNET CABLE TO THE NMIC EIM SNMP PORT

**Summary:** This procedure provides instructions for connecting an external Network Management System (NMS) or X-Terminal to the NMIC EIM 10 Base-T Ethernet port on the NMIC EIM at the rear of the shelf. The cable from customer monitoring equipment (X-Term, etc.) must be equipped with an RJ45X LAN connector. The function of the 10 Base-T Ethernet port is to provide the System Administrator with capabilities of monitoring system and network alarms, provisioning virtual paths/connections, and performing maintenance and provisioning functions. The connection will allow access to either NMIC using a shared IP address, or an individual NMIC using a NMIC specific IP address.



**Caution:** *Modules can be damaged by static electrical discharge. Before handling any modules connect your wrist to an equipment ground using an approved anti-static wrist strap. Ensure that all un-installed modules are stored in anti-static packing material. When working with modules, always place the module on an electrically grounded approved anti-static mat.*

1. If not already equipped and verified, equip the customer LAN cable with an RJ45X male connector and verify the connector wiring per Figure 704-1.
2. Route the LAN cable to the lower right side of the Cellworx STN shelf (facing the rear), to terminate at the working NMIC EIM in slot 2. Refer to Figure 704-2. If the NMIC EIM is not installed, you must first perform the installation procedure for this module. Refer to the Installation Manual listed in the Related Publications section in the preface of this document, and then return to this procedure.
3. Dress in the cable leaving enough slack to reach the RJ45X jack on the EIM. Cable ties may be used to attach the cables to the tie bar along the bottom of the air intake baffle. Verify that enough strain relief and maintenance loop are provided.
4. Seat the RJ45X connector into the NMIC EIM RJ45X LAN jack. Verify the latch catches by gently tugging once or twice on the cable.
5. The NMS end of the cable should then be connected to the X-terminal per local practices.

**Stop! You have completed this procedure.**

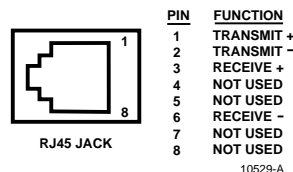

Figure 704-1. NMIC EIM RJ45 Jack Pin Out

DLP-704  
Page 2 of 2

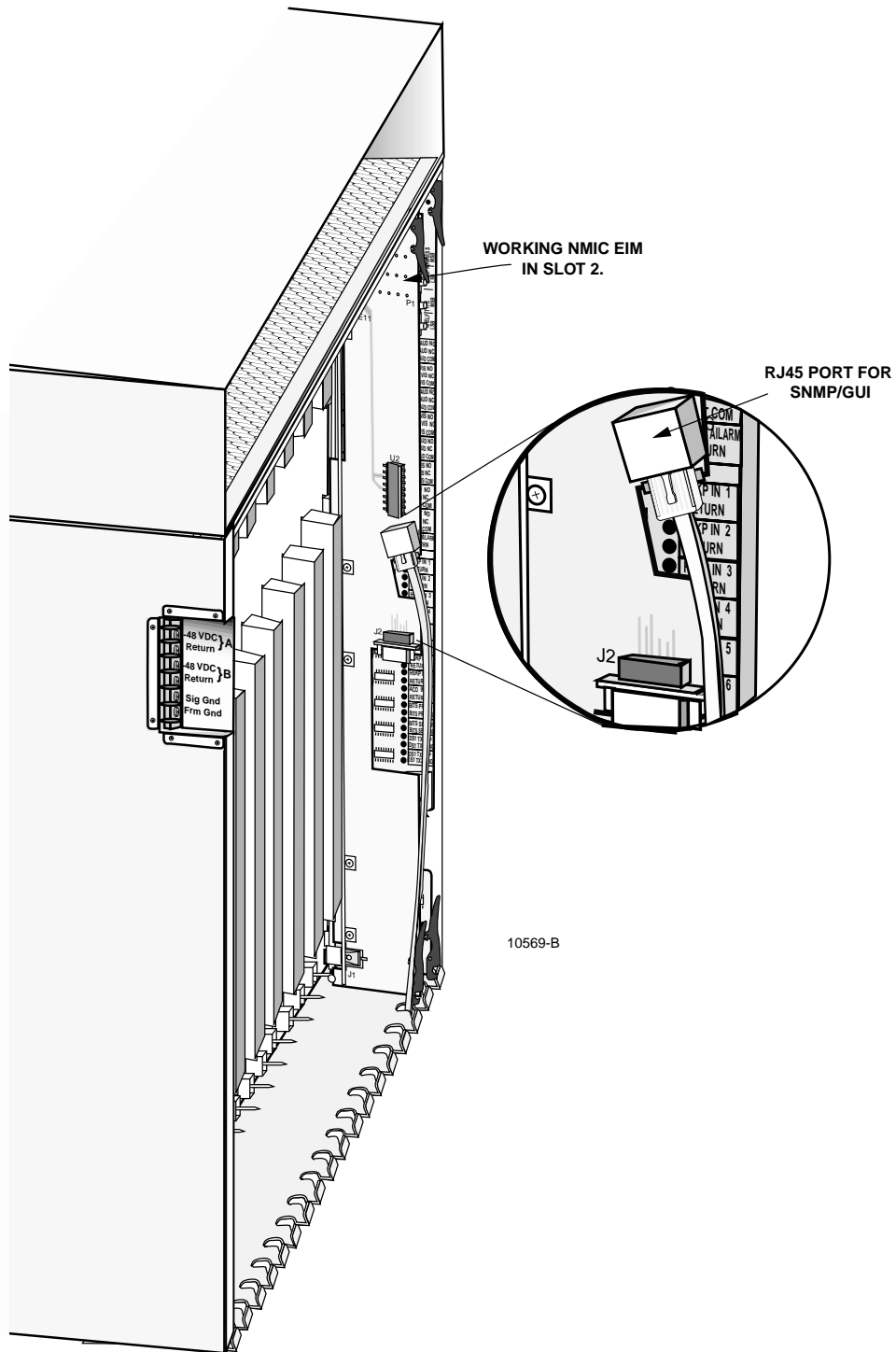

Figure 704-2. NMIC EIM LAN Port Connection

## LAUNCH THE GRAPHICAL USER INTERFACE (GUI)

**Summary:** This procedure describes the processes involved to successfully logon to the system and launch the Graphical User Interface (GUI).

1. Verify the IP address set on the NMIC using a “ping” command to both NMIC IP addresses by typing: ping xxx.xxx.xxx.xxx (xxx = 255 or less) to ensure both EIMs are operational. The pings should display on the screen. If the ping delays returning a response and times out, check Ethernet connection cabling and also verify the correct NMIC IP address was entered.
2. Establish a Telnet session to the active NMIC using the customer defined IP address set in DLP-703 (or set up a connection name on X-Terminal for the particular NMIC and select it.)
3. Export the display to the X-Terminal IP address using this command:

```
export DISPLAY=<hostname>:0.0
```

- ▶ **Note:** Hostname is the IP address of the workstation. To determine the IP address of the host, see your system administrator.
5. A log on screen appears prompting the user to enter a login name and password. If this is the first time the system has been turned up, the name should be “root”. The password is user defined and should be the same as the one selected in DLP-703.
  6. The Graphical User interface (GUI) can be launched once the connection is established by entering “CellworxVision”. It may take a few moments for the GUI to come up. When it does, it will request a list of NEs and fiber fragments and will display them (if they have been discovered previously) as a network view as shown in the example in Figure 705-1. A window appears on the GUI that indicates the tasks that the GUI is performing in the background. This window is not needed by the user and may be closed by selecting the *Close* button.
  7. If performing initial turn up of a new ring network, the NE and Fiber Fragment requests will both return empty since a discovery has not previously been requested on the new NMIC. The system is now ready for initial turn-up. Return to NTP.

**Stop! You have completed this procedure.**

DLP-705  
Page 2 of 2

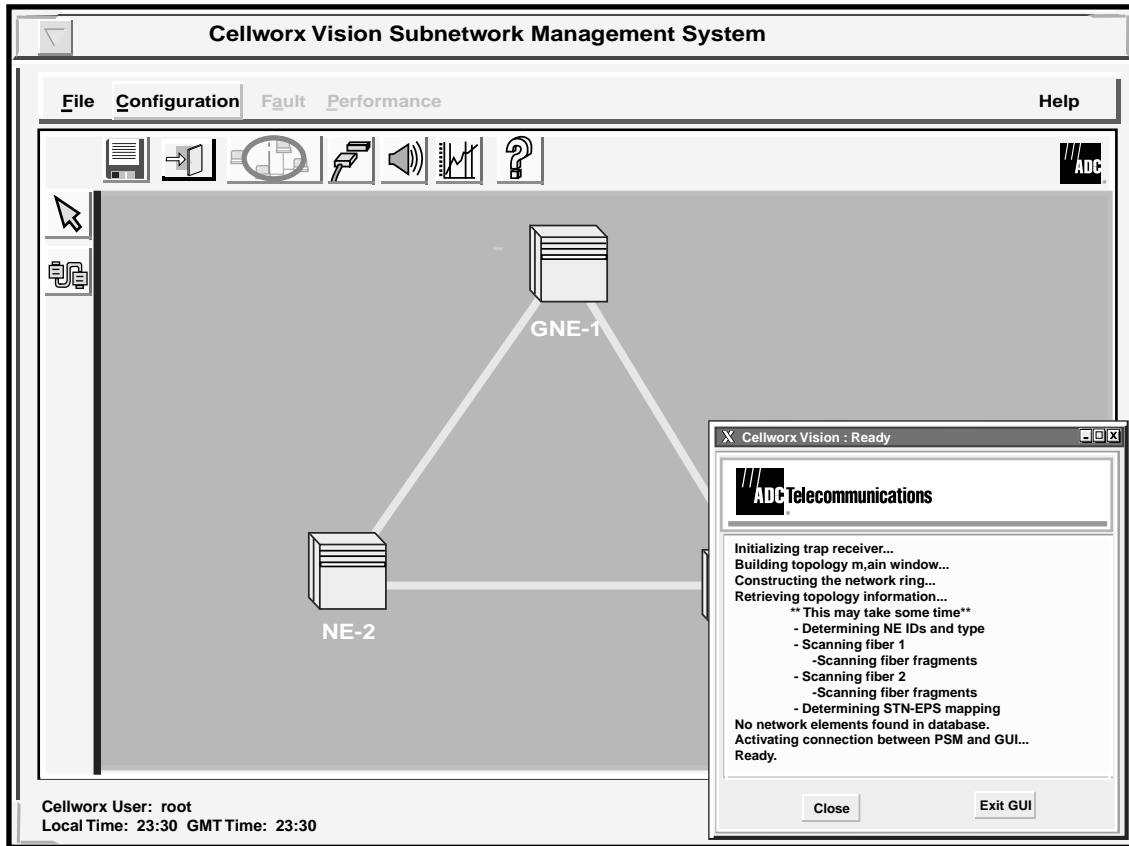

11723-D

Figure 705-1. NMIC GUI Network Display (example)

## PERFORM DISCOVERY ON A NEW CELLWORX STN RING NETWORK

**Summary:** This procedure describes the steps required to successfully turn-up and discover a new Cellworx STN ring network. Discover is the term used to initiate a search by the GUI to find all ring nodes that are connected and powered up in the network. This procedure assumes the user has gained access to and launched the Graphical User interface (GUI), and the list of NEs and fiber fragments has been returned empty (no NE Icons displayed on the screen). Prerequisites to system Turn-up are as follows:

- The X-Terminal must be functional and have launched the Cellworx STN GUI.
- All nodes in the network must have fibers connected, and be powered on.
- All nodes in the network must have the working SC EIM shelf address set for individual identification (Refer to the Installation Manual listed in the preface of this document.)

► **Note:** User navigates through the GUI menus using the mouse, or by using the Alt plus the underlined letters in the menus and then the arrow keys to scroll up, down, or across. Refer to the Graphical User Interface Operation in Section 2 of this document.

1. When the GUI is launched for the first time, a pop-up message informs the user to “Turn-up Ring”. Refer to Figure 706-1. Select **OK**. The only user options available on the GUI screen prior to initial turn-up are the pull down menus **File – Exit**, or **Configuration – Topology – Turn-Up Ring**. The **Help – Contact** and **About** menus are selectable at all times and will display the information shown in Figures 706-2 and 706-3 respectively. Another window always appears on the GUI screen showing the tasks the software is performing in the background. This window may be closed by selecting the close button.
2. Click the left mouse button on the **Configuration** pull down menu to open it.
3. Next, click the left mouse button on **Topology** on the pull down menu.
4. Next, click the left mouse button on the **Turn-Up Ring** option. User may also elect to use the alt key options **Alt+C**, **Alt+T**, and **Alt+T**. Refer to Figure 706-4.
5. The Select Network Elements window appears as shown in Figure 706-5. Select the identifiers (01 through 50) of the ring nodes only (not expansion shelves) in a sequential order as they are physically connected around the ring. The sequence entered will be displayed in the Order of Connectivity area of the window. If an id is entered in the wrong sequence, the user must hit **Clear** and enter the entire sequence again.
6. Once the sequence is entered correctly, hit **Next**. A confirmation window appears with a list of the shelf ids entered, reflecting the physical connection in the network. Refer to Figure 706-6. The last NE address entered will indicate that it is connected to the first NE entered to form a ring network.

**DLP-706**

Page 2 of 11

7. Verify that the NE id sequence is correct and hit *Next*. If sequence is wrong hit *Previous* and return to step 5.
8. The Current Status window appears as shown in Figure 706-7. If the NEs have previously booted, the status shows “NE booted, Select software image”. See Figure 706-8. If so double click on each NE using the left mouse button and go to step 10, otherwise, all NEs status should read “Waiting for NE to boot”. “Waiting for all NEs to boot” is displayed at the bottom of the window. Follow the instructions at the top of the window.
9. When each NE completes the boot process, select each NE by double clicking on it using the left mouse button
  - ◆ **Note:** It is necessary to open the Install Software window for each NE so the NMIC can verify the status of the RICs and the software selections to be loaded on them.
10. The Install Software Load window for the selected NE appears displaying the cards equipped in each slot of the shelf, and the current running software versions. See Figure 706-9. If the screen is opened immediately following boot up, it is possible that the SCs will not have had time to discover the cards in the shelf and the screen will appear empty (except for the SCs). Select a software image for the RIC cards by selecting and holding the right mouse button on the row of the card to be loaded. A pop-up window appears displaying any images for that card that are stored on the NMIC.
11. Select a software version displayed in the pop-up window and release the mouse button. The version is now listed in the Selected Software Image column on the right.
12. Repeat the software image selection for the remaining RIC card and any AIC cards that need to be configured. Once all new images have been chosen, select *Apply*. Selecting *Apply* before choosing software images brings up the instructional window shown in Figure 706-10. Selecting the *Clear Selected* button will reset all selected software images leaving the last column blank. *Refresh* can be selected periodically to update all information in the window. Selecting *Cancel* will close the window and no software versions will be changed.
13. Select *Refresh* periodically until the selected software image becomes the running software image. This may take up to twenty minutes per NE dependent upon card configuration in the shelf, number of NEs in the ring, distance between NEs, etc.
14. Once the software images have been configured successfully, the confirmation pop-up window appears. Refer to Figure 706-11. This window appears immediately after Apply is selected but it does not indicate that the RICs have booted. Select *OK* and then *Cancel* the Install Software Load window.
15. The Current Status window reappears and the NE status changes to “RICs have booted, NE eligible for discovery”. Repeat steps 10 through 16 for each NE configured, then continue to step 17.



16. Once the last NE has gone through the Install Software Image window and all RICs have booted successfully, the message window shown in Figure 706-12 appears. This window informs the user that all RICs have booted and that the network is ready for discovery. The Initiate Discovery button on the Current Status window is now enabled.
17. Select **Initiate Discovery**. The status for the NEs changes one at a time from “NE eligible for discovery” to “Discovering NE”. Once the discovery process is completed on an NE, the status changes to “NE discovered”. Refer to Figure 706-13 for an example of NE-1 completing discovery, NE-2 in process of discovery, and NE-3 awaiting discovery.
18. When the discovery is completed on all NEs, the system draws them in a ring configuration on the screen according to their connectivity. To redraw the layout of the Icons before saving the system drawn layout, select the arrow tool on the toolbar on the left side of the screen, click on and drag the NEs to the desired position on the screen, and release the left mouse button. See Figure 706-14.
19. The Icons now stay positioned in the new locations and maintain the highlighted connection between them. This capability enables the user to group NEs that may be collocated or separate them according to their geographical locations. The user may also return the icons to their original positions on the screen by selecting the **Configuration** pull down menu, **Topology**, and **Revert to Saved ICON Layout** or **Alt+C**, **Alt+T** and **Alt+V**. Refer to Figure 706-15.
20. To save the icon layout displayed on the screen, select **File** and **Save Icon Layout (Alt+F and Alt+S)**, or use the diskette icon on the tool bar. See Figure 706-16.
21. The confirmation window appears as shown in Figure 706-17. Select **OK**. The newly drawn Icon layout will remain this way each time the GUI is launched, until the layout is redrawn and saved again.

**Stop! You have completed this procedure.**

DLP-706  
Page 4 of 11

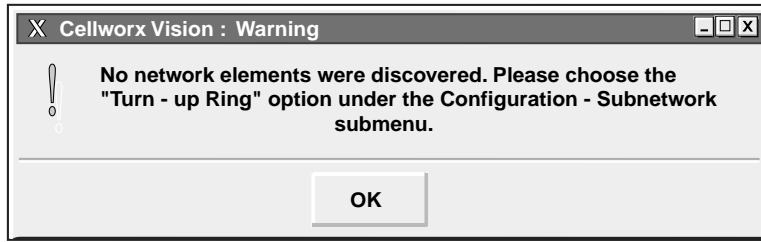

11761-A

Figure 706-1. Cellworx Vision Turn-up Ring Warning Window



10909-E

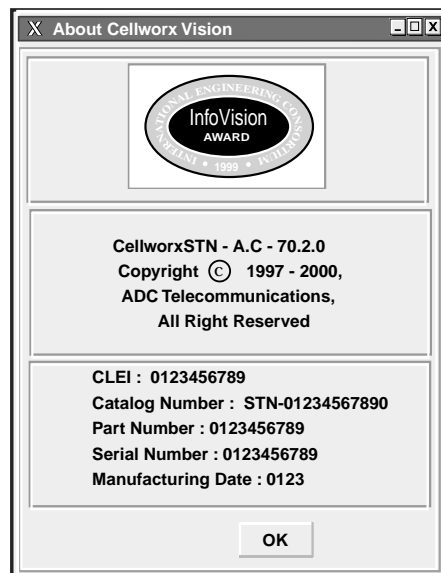

10886-D

Figure 706-2. Cellworx Vision Help Contact Window

Figure 706-3. Cellworx Vision Help About Window

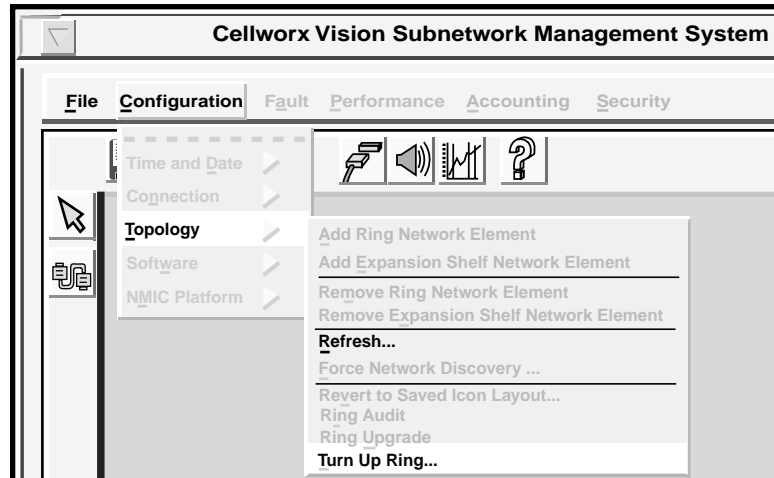

11012-E

Figure 706-4. Cellworx Vision Turn-up Ring Pull Down Menus

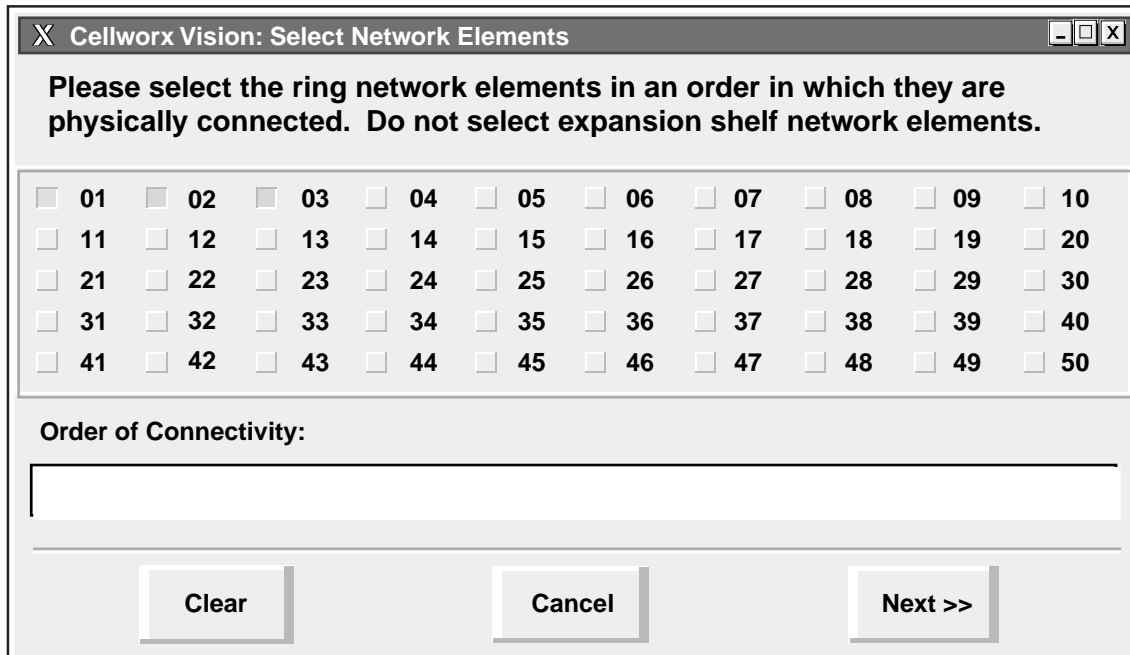

10990-B

Figure 706-5. Cellworx Vision Select Network Elements Window

DLP-706  
Page 6 of 11

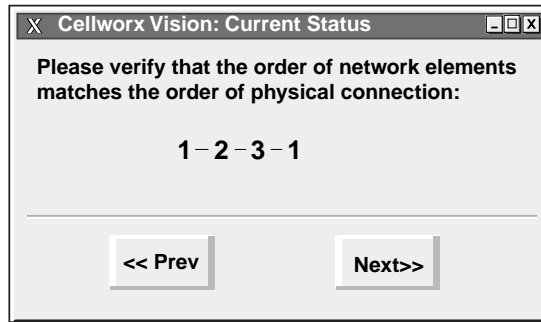

11013-B

Figure 706-6. Cellworx Vision NE Order Verification

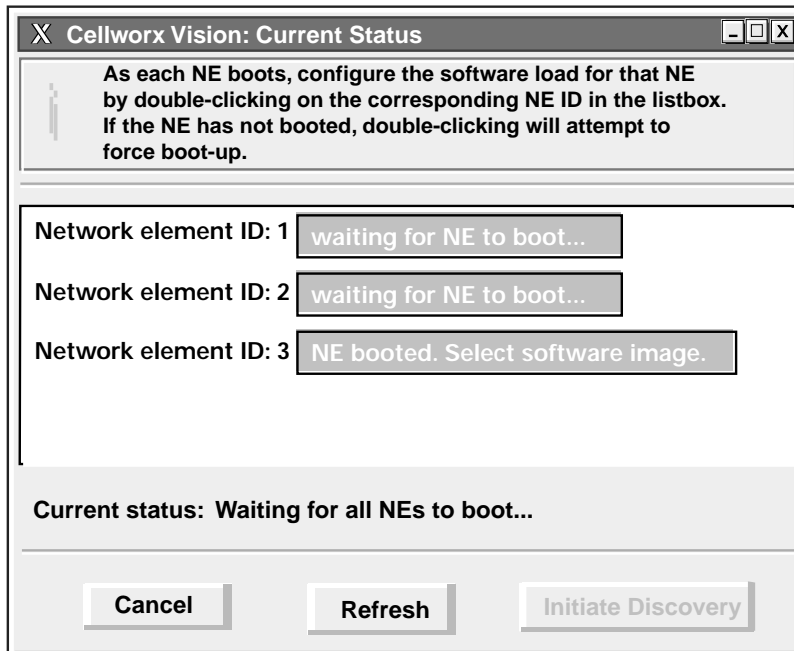

10910-C

Figure 706-7. Cellworx Vision Current Status Window,  
Waiting for NE to Boot

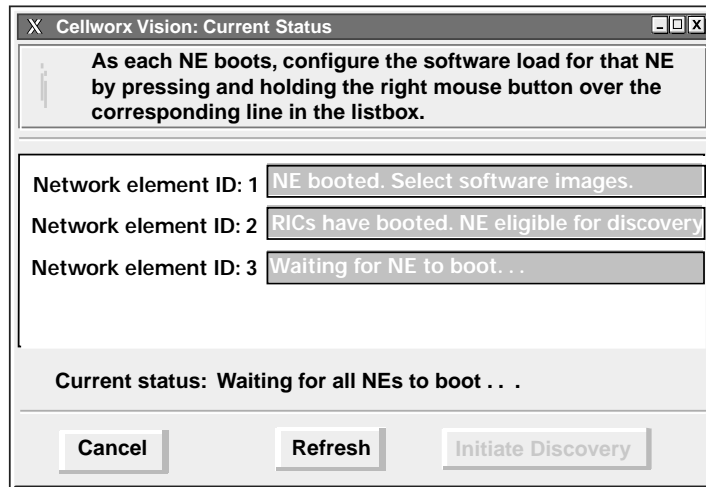

10912-B

Figure 706-8. Cellworx Vision Current Status Window, NE Boot Process

DLP-706

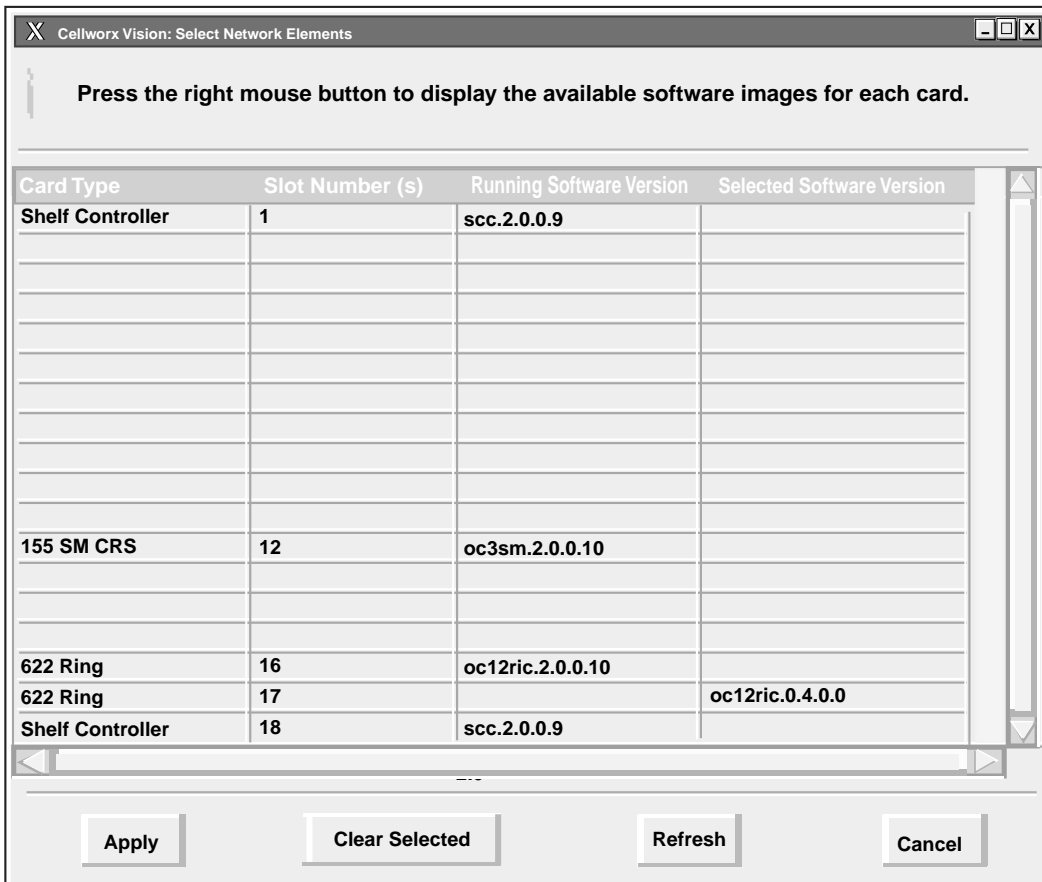

10901-C D

Figure 706-9. Cellworx Vision Install Software Load

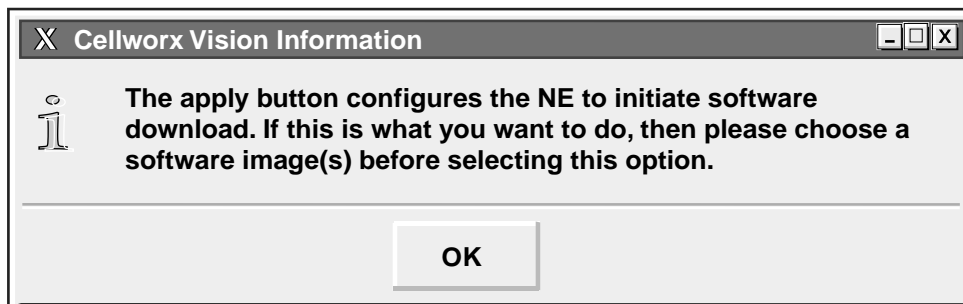

10933-B

Figure 706-10. Cellworx Vision Software Selection Instructional Window

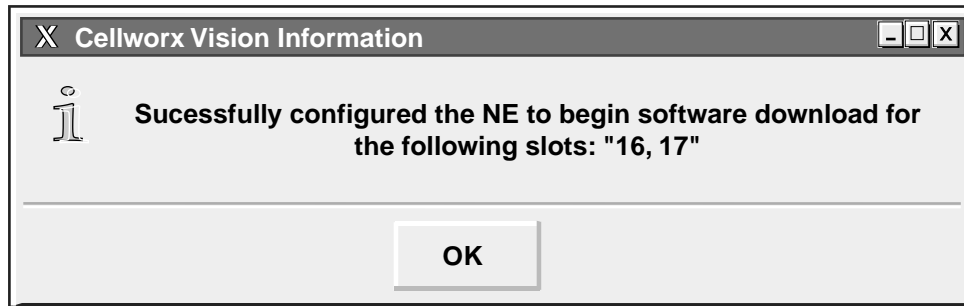

10934-C

Figure 706-11. Cellworx Vision Successful Software Image Download Message

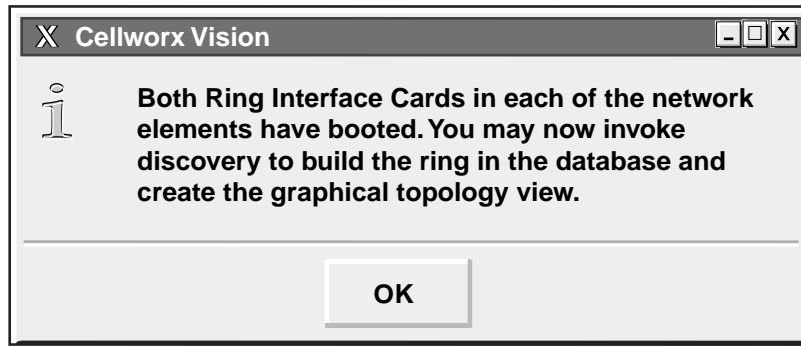

10935-B

Figure 706-12. Cellworx Vision NE Eligible for Discovery Instructional Window

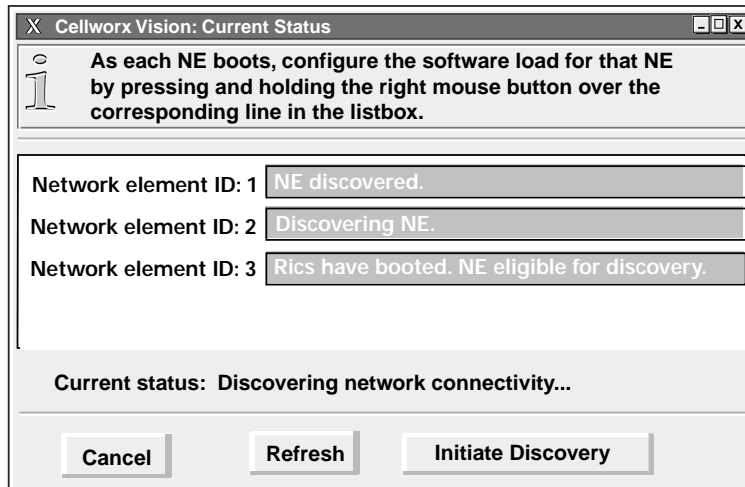

10914-C

Figure 706-13. Cellworx Vision NE Current Status Window

DLP-706  
Page 10 of 11

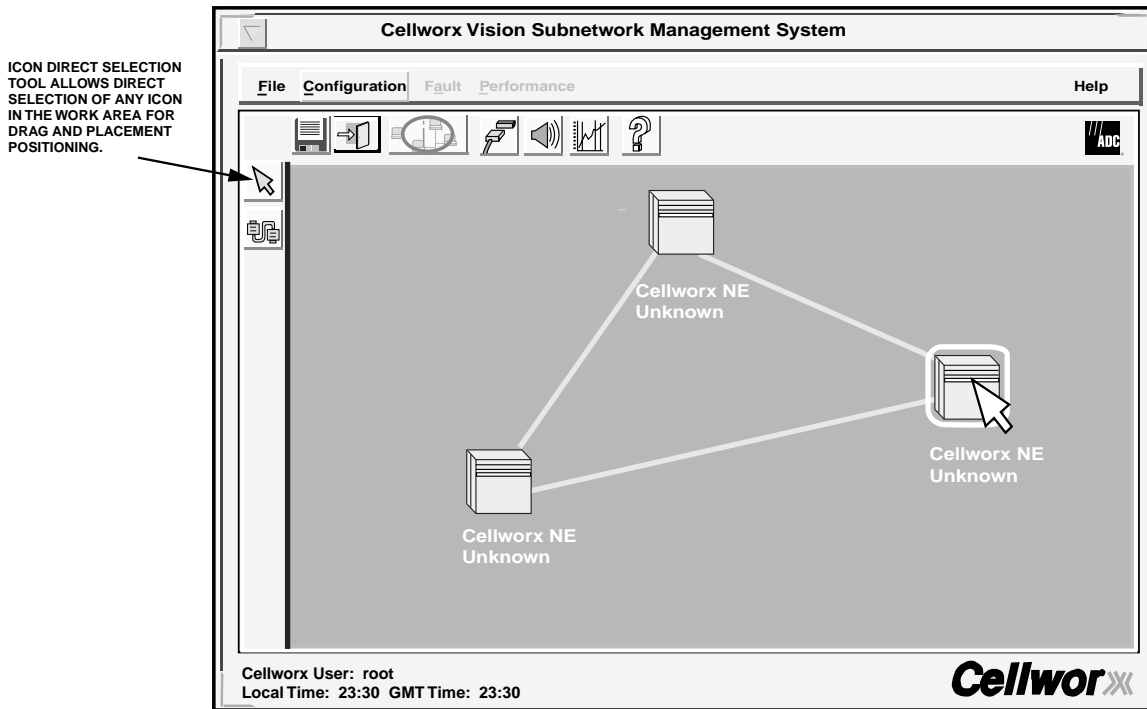

11720-D

Figure 706-14. Cellworx Vision Redrawing ICON Layout

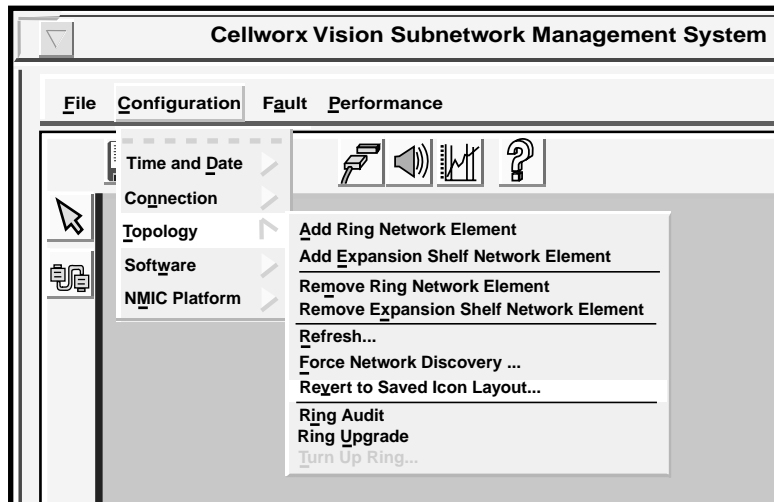

10972-E

Figure 706-15. Cellworx Vision Redraw Icon Layout Pull Down Menu



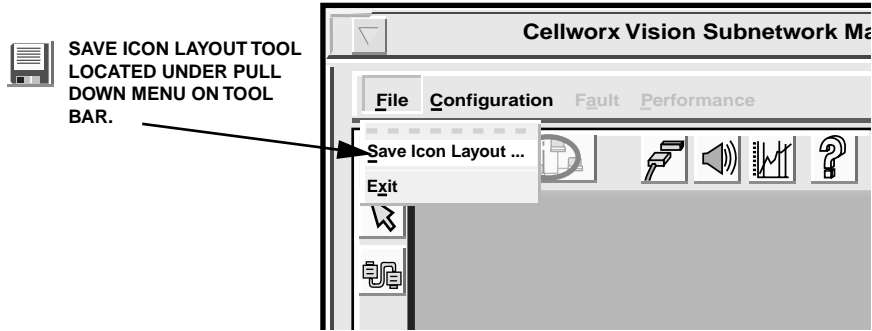

11755-B

Figure 706-16. Save New Icon Coordinates

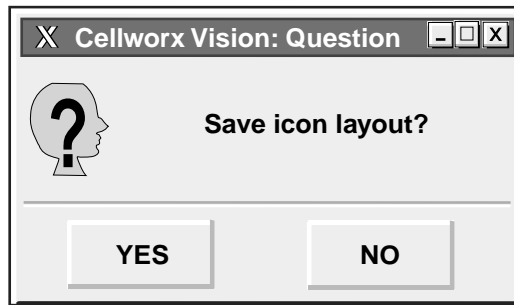

10986-B

Figure 706-17. Save Icon Layout Confirmation

## DLP-707

Page 1 of 3

### TIME AND DATE

**Summary:** This procedure describes the steps required to set the system clock at the NMIC in the Gateway Network Element (GNE). The NMIC maintains the system clock for the entire network and supports requests from the system administrator to change the system clock. The NMIC synchronizes every NE's time-of-day clock to the NMIC time-of-day clock.

1. Using the left mouse button, select the *Configuration* pull down menu, and then select the first item *Time and Date* (or hit *Alt+C*, and *Alt+D*).
2. Select either *Absolute* (*Alt+A*) or *Relative* (*Alt+R*) and go to the appropriate heading below. Refer to Figure 707-1.

◆ **Note:** Absolute allows the user to set the time and date to the absolute time specified. This is needed for turn-up or instances when the clock is more than an hour off. Relative allows the user to adjust the clock in seconds either forward or backwards, up to one hour, when smaller adjustments are needed.

#### Absolute

3. The NMIC Absolute Time Change window appears. See Figure 707-2.
4. The currently provisioned date and time are displayed. To change any of these parameters, use the left mouse button to select the current month, day of the week, year, hour, minute, and second by clicking on the up or down arrows beside each data field.
5. After all selections have been made, select *Apply*.
6. Select *Refresh* to update the new date and time displayed in the window. The new time information is automatically downloaded to each NE.
7. Select *Close* to return to the Cellworx Vision screen.

**Stop! You have completed this procedure.**

#### Relative

8. The NMIC Relative Time Change window appears. See Figure 707-3.
9. The local time and GMT (Greenwich Mean Time) are displayed. To adjust the current local time, enter the number in seconds from 1 to 3600 (1-hour) that the clock needs to be adjusted.
10. Select either *backward* or *forward* to adjust the time appropriately.
11. Select *Apply* to send the new data and adjust the clock.

12. Select **Refresh** to update the current running local and GMT times displayed in the window. The new clock information is downloaded automatically to each NE.
13. Select **Close** to return to the Cellworx Vision screen.

**Stop! You have completed this procedure.**

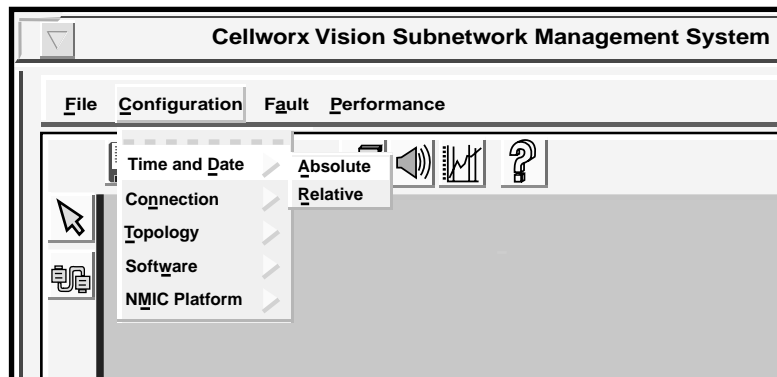

10977-D

Figure 707-1. Cellworx Vision Time and Date Pull Down Menu

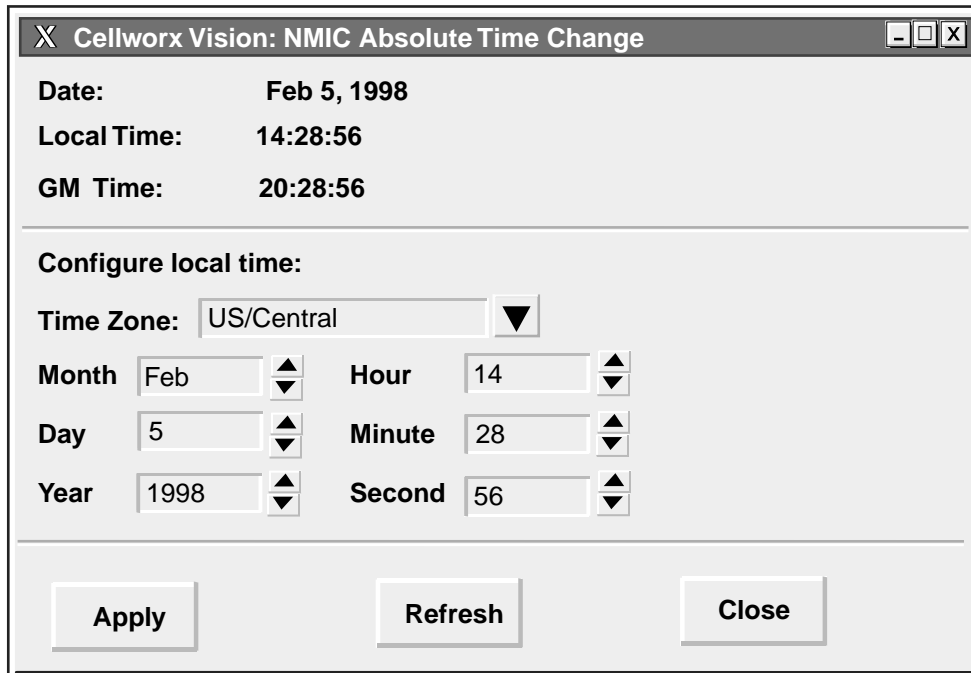

11005-C

Figure 707-2. Cellworx Vision Absolute Time Change Window

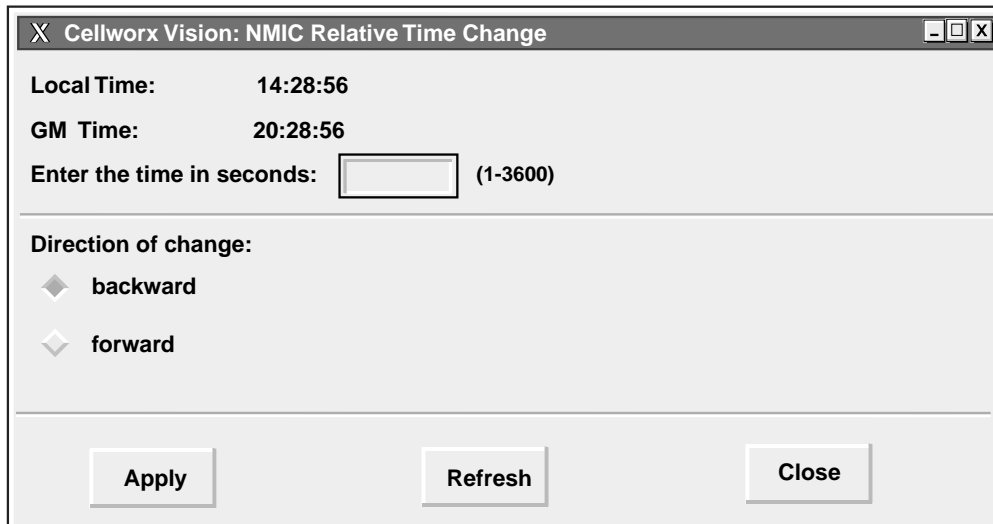

11006-C

Figure 707-3. Cellworx Vision Relative Time Change Window

## CREATE AN ATM OR CES CONNECTION

**Summary:** This procedure describes the steps required to provision a UBR, CBR or VBR connection through the Cellworx STN network. Creating a connection entails selecting the originating and terminating NEs, cards, ports, specifying whether the connections are VP, VC, CES, UNI, NNI, or a combination of and assigning identifiers and traffic contract types. For Frame Relay connections refer to DLP-786, for ATM Multicast connections, refer to DLP-787, and for ATM Bundled VC Multicast connections, refer to DLP-790. Traffic contracts will be discussed in this procedure but performed elsewhere. Prerequisites of establishing a connection are:

- A discovery must have been performed on the system.
- The connection endpoints hardware (cards/ports) must be provisioned and in service (unlocked) per NTP-006.

► **Note:** User may navigate through the GUI menus using the mouse or by using the Alt key plus the underlined letters in the menus simultaneously, and then the arrow keys to scroll up, down, or across. Refer to the Graphical User Interface Operation in Section 2 of this document.

1. There are three ways to initiate the process of establishing a connection.
  - a. Using the left mouse button, select the *Configuration* pull-down menu, click on *Connection*, and then *Create* (or press *Alt+C*, *Alt+N*, *Alt+C*.) Refer to Figure 708-1.
  - b. Using the Select tool (arrow) on the left toolbar, select the NE where the connection is originating by a click and hold on the right mouse button. A pop-up window appears as shown in Figure 708-1. Continue holding down the right mouse button and move the cursor to select *Create Connection*. Release the mouse button.
  - c. Using the left mouse button, select the connection tool on the toolbar to the left of the workspace. Click and hold the left mouse button down on the NE where the connection is originating and drag to the destination NE. A line is drawn between the two NEs as the crosshair pointer progresses. Refer to Figure 708-2.
2. The Cellworx Vision Connection Configuration window appears displaying all NEs discovered in the network in both the top section and the bottom section of the window. Refer to Figure 708-3. Ensure the originating and destination NEs are highlighted, if not, select them using the left mouse button.
3. Enter an identification for the connection in the Connection Name text box using any alphanumeric and special characters. This ID should be unique in character so the user can discern between it and other connections for management purposes. The IDs assigned here will be displayed when viewing connections. System will allow duplicate connection names but will also assign a unique ID to the connection if the user does not enter one.

**DLP-708**

Page 2 of 7

4. Following the example shown in Figure 708-3, specify the connection type by left mouse clicking on the **Connection Type** pull down menu and selecting the type desired. The window displays the interfaces related to the Connection Type as follows:
  - ATM VP–ATM VP
  - ATM VC–ATM VC
  - CES-ATM VC
  - CES-CES
  - FR-ATM VC
  - FR-FR
  - ATM VP MULTICAST
  - ATM BUNDLED VC MULTICAST
5. Using the left mouse button, select the desired NE, Slot/Card Type, and Interface type for the originating and destination endpoints. Click on **Next>>** using the left mouse button unless the connection is a CES-CES where the user should select the **Apply** button which will produce an informational screen stating that the connection was created successfully. If provisioning CES-ATM connections, continue, otherwise go to step 7.
6. When the CES-ATM VC is selected, the Connection Configuration screen shown in Figure 708-4 appears after selecting **Next>>** from step 5. The network element identifications for both end points are displayed
7. The screen shown in Figure 708-5 appears after selecting the **Next>>** button from step 5. The two sections below the Connection Name text box of the next window represent the two connection points.
8. If the connection is to be configured as a segment endpoint, select the Segment Endpoint box using the left mouse button for both the originating and destination ends. This option will enable OAM cell loopback from this point to the originating end for performance monitoring capabilities.
9. Just below the Segment Endpoint boxes under the heading VPI / NE / Rate (Kbps), select the VPI number to be assigned for each NE if establishing a VP connection.
10. To the right the Service Provider Profile is displayed. Fill in the text boxes for each of the following parameters:
  - **Remote Interface Identifier** - a fifteen-digit decimal number identifying the far end interface (UNI or B-ICI).
  - **Remote Connection Identifier** - a four-digit VPI or five digit VCI decimal number identifying the VCI and/or VPI at the remote interface.

- **Study Indication** - select using the left mouse button. This indicates the usage information is to be generated for study purposes.
  - **Remote Interface Type** - select UNI or B-ICI using the left mouse button. This selection describes the type of remote interface.
11. When all of these parameters are filled in for both the originating and the destination NE, select *Next* , except for CES ATM VC connections in which the user selects the *Apply* button to complete the connection.
  12. The next window appears for ATM connections and prompts the user for more information. Refer to Figure 708-6. The Connection Name and Type are displayed at the top of the window. The Traffic Contract Type needs to be selected dependent upon the type of connection selected in the previous windows. For ATM-VP connections, classes selectable are CBR (Constant Bit Rate), UBR (Unspecified Bit Rate), UBR.1, RT-VBR 1, 2, or3 (Real Time Variable Bit Rate). Or NRT-VBR 1, 2, or 3 (Non-Real Time Variable Bit Rate). For ATM-VC connections, NRT-VBR 1, 2, or 3 , or UBR , UBR.1, or CBR are selectable.
- **Note:** The Cellworx STN system can support any ATM Forum UNI 3.1 based traffic contracts. UNI 3.1 uses QoS Classes 0 through 4 to specify the service requirements and these can be mapped to Cellworx STN Classes I, II, and Unspecified. The Cellworx STN also supports ATMF UNI 4.0 based traffic contracts. UNI 4.0 uses parameterized QoS, which can be mapped to STN classes I, II, or Unspecified based on the QoS parameter values. There are five traffic contract types (i.e. conformance definitions) for different service categories. Table 708-1 shows the relationship between the traffic contract types and the QoS class assigned to it in the Cellworx STN.

Table 708-1. Traffic Policing Attributes for Various Service Categories

TRAFFIC CONTRACT TYPES	PCR	SCR	MBS	TAGGING OPTION ACTIVE	QoS
CBR.1	0 + 1	Not specified	Not specified	Not applicable	Class I
VBR.1	0 + 1	0 + 1	0 + 1	Not applicable	Class II
VBR.2	0 + 1	0	0	NO	Class II
VBR.3	0 + 1	0	0	YES	Class II
UBR	Not specified	Not specified	Not specified	Not applicable	Unspecified
UBR.1	0+1	Not specified	Not applicable	Not applicable	Unspecified

13. Next select the Ingress Traffic Contract using the left mouse button. If a traffic contract is not available for the connection, double click on *NEW* to create a traffic contract and go to DLP-709. The traffic contract specifies the parameters that determine if the connection is actually a CBR, RT or NRT-VBR.1, VBR.2, or VBR.3, UBR, or UBR.1 connection.
14. Once traffic contract is created, it will appear in the Ingress Traffic Contract window. Select the new traffic contract via a single click using the left mouse button.

DLP-708

Page 4 of 7

15. Select **Apply** using the left mouse button to configure the connection. If the traffic contract was not selected, a message window will appear asking the user to select a Traffic Contract first. If the connection could not be established due to other conditions, a trouble message will appear giving more specific error messages.
16. The system responds with “Configuration Successful”.

**Stop! You have completed this procedure.**

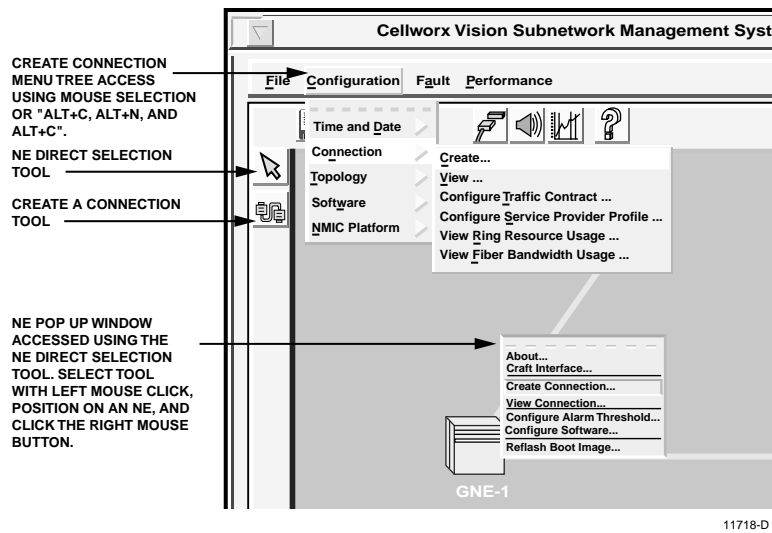

Figure 708-1. Cellworx Vision GUI Configuration Pull Down Menu

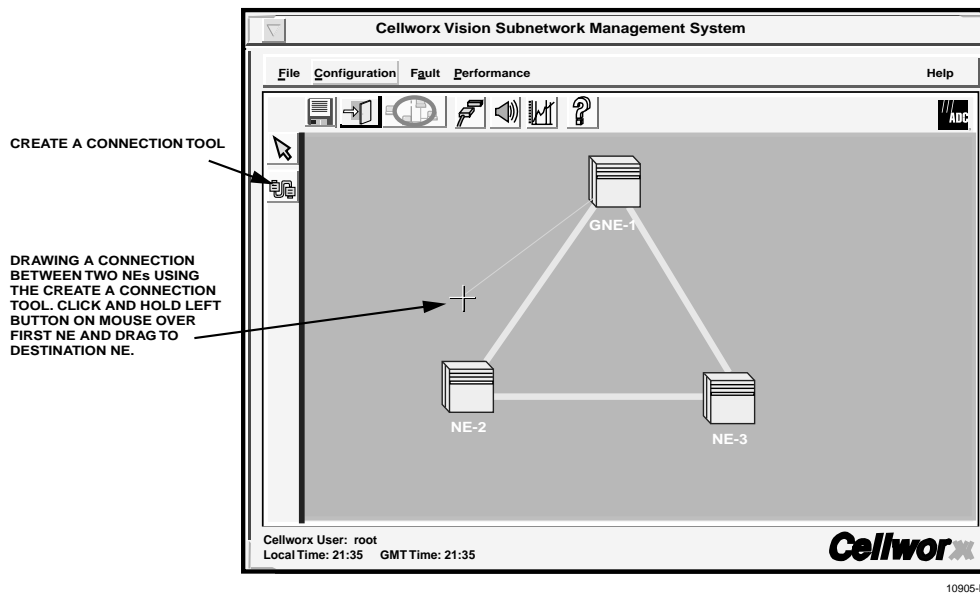
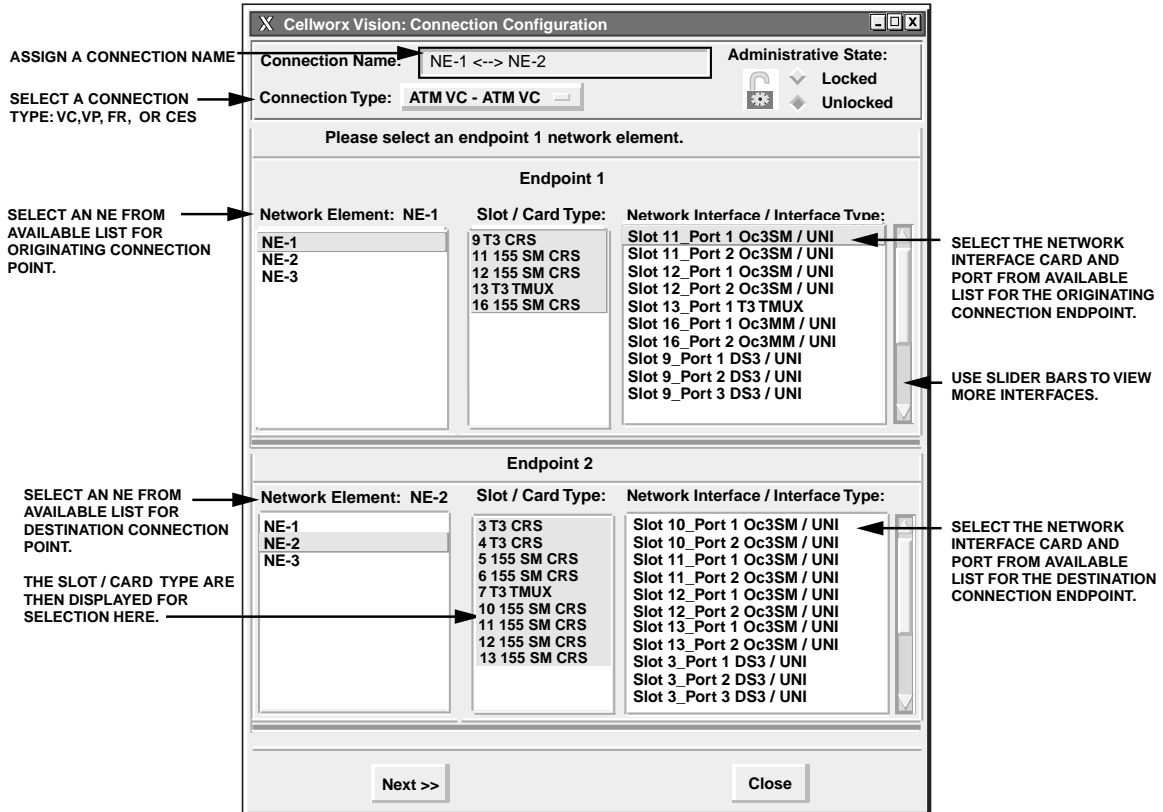

Figure 708-2. Cellworx Vision Click and Drag Connection Creation





10907-C

Figure 708-3. Cellworx Vision ATM Virtual Connection Configuration Window

DLP-708  
Page 6 of 7

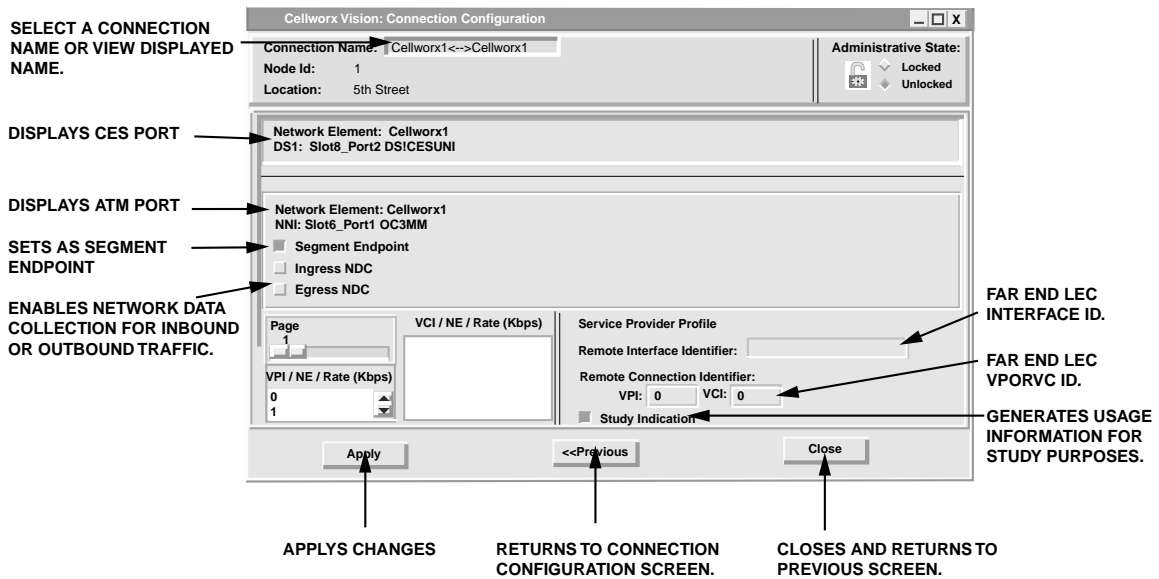

Figure 708-4. CES - ATM VP Connection Configuration Window

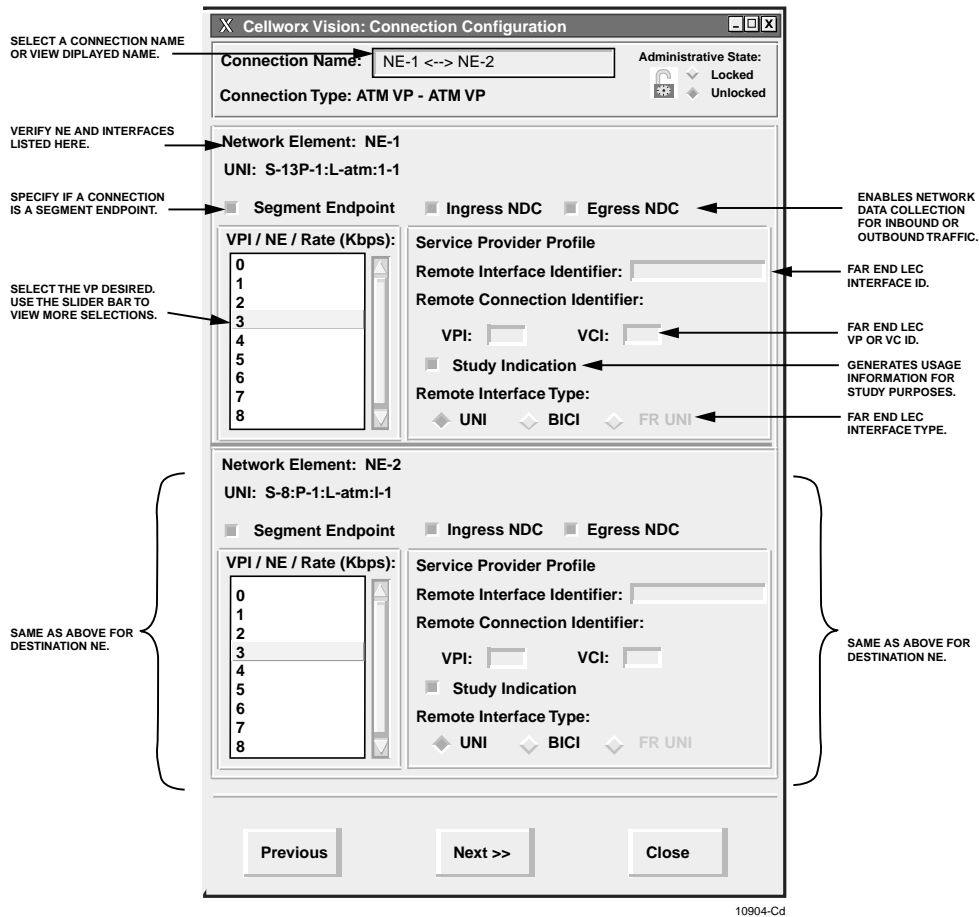

Figure 708-5. Cellworx Vision Connection Configuration Window

The screenshot shows the 'Cellworx Vision: Connection Configuration' window. It contains the following fields and controls:

- Connection Name:** NE-1 <--> NE-2
- Connection Type:** ATM VP - ATM VP
- Locking:** Locked/Unlocked toggle with a lock icon.
- NE-1 Section:**
  - UNI: ds1ces: S-3: P-3: L-atm: I-1 VPI: 1
  - Service Class Type: CBR
  - Ingress Traffic Contract: <NEW>
- NE-2 Section:**
  - UNI: Slot8:Port1 OC3SM VPI: 5
  - Service Class Type: CBR
  - Ingress Traffic Contract: <NEW>
- Buttons:** Apply, Refresh, << Previous, Close

Annotations on the left side of the window:

- DISPLAYS NAME AND TYPE OF SELECTED CONNECTION. (points to Connection Name)
- VERIFY INTERFACE AND VPI BEING CONFIGURED. (points to NE-1 UNI)
- SELECT A QOS CLASS. (points to Service Class Type)
- SELECT A TRAFFIC CONTRACT FROM AVAILABLE LIST OR SELECT NEW TO CREATE A NEW TRAFFIC CONTRACT. (points to Ingress Traffic Contract)
- VERIFY DESTINATION INTERFACE AND VPI BEING CONFIGURED. (points to NE-2 UNI)
- SELECT A QOS CLASS. (points to Service Class Type)
- SELECT A TRAFFIC CONTRACT FROM AVAILABLE LIST OR SELECT NEW TO CREATE A NEW TRAFFIC CONTRACT FOR DESTINATION NE. SAME TRAFFIC CONTRACT CAN BE USED FOR BOTH NEs. (points to Ingress Traffic Contract)
- SELECT APPLY TO CONFIGURE THE NEW CONNECTION. (points to Apply button)

14452-A

Figure 708-6. Cellworx Vision ATM Virtual Path Connection Configuration

**DLP-709**

Page 1 of 4

**CONFIGURE OR DELETE A TRAFFIC CONTRACT**

**Summary:** This procedure describes the steps necessary to successfully navigate the Cellworx Vision Graphical User Interface and create or delete a traffic contract. A traffic contract defines the service class type (CBR, VBR, or UBR), data rate, and Quality of Service (QoS) and must be specified for each Virtual Channel Connection (VCC) or Virtual Path Connection (VPC) established. Multiple VCCs or VPCs may share a common traffic contract. Once a traffic contract has been created it cannot be changed. It must be deleted and recreated.

**Create a Traffic Contract**

1. Access the Traffic Contract Configuration using the left mouse button by selecting *New* from Create Connection DLP-708, or select *Configuration, Connection, and Configure Traffic Contract*, or by using the direct selection keys, *Alt+C*, *Alt+N* then *Alt+T*. Refer to Figure 709-1.
2. The Traffic Contract Configuration window appears. Refer to Figure 709-2. Enter identification for the contract being created in the Traffic Contract Name text box.
  - ◆ **Note:** Any existing contracts are displayed in the box just below the Traffic Contract Name box. These may be selected to configure a new contract using existing parameters. To do this, single click on one of the contracts and enter a new name in the box above, then select *Apply* at the bottom of the window.
3. Select a Service Class Type from the available classes displayed. See Table 709-1.
4. Select options for the traffic contract from available parameters per work order. Some of these parameters will not be selectable depending on the Service Class Type selected. Refer to Table 709-1 for selectable options for each Service Class Type.

**Table 709-1. User Selectable Service Class Types and Parameters**

SERVICE CLASS TYPE	SELECTABLE PARAMETERS	COMMENTS
ATM CBR, QoS Class I	Peak Cell Rate (PCR) Kbps Cell Loss Priority (CLP) = 0 + 1	Card type and contract dependent. QoS Class I defined, not selectable.
ATM VBR, QoS Class II	Peak Cell Rate (PCR) Kbps  Sustained cell rate (SCR) Cell Loss Priority (CLP)  Tagging  Maximum Burst Size (MBS)	Card type and contract dependent, CLP always equals 0+1.  Card type and contract dependent. Determines if SCR connection is a VBR.1 (CLP=0+1) or VBR.2 (CLP=0). Determines if SCR connection is a VBR.2 (No) or VBR.3 (Yes). Predetermined selectable values of 32, 50, 100, 150, or 210. See note below.
ATM UBR, QoS Class Unspecified	None	Select PCR for UBR.1, PCR must be blank for UBR.

- ▶ **Note:** Three traffic descriptors must be provided for the connections to set the cell transfer characteristics: Peak Cell Rate (PCR), Sustained Cell Rate (SCR), and Maximum Burst Size (MBS). The PCR is the highest available cell transfer rate for VBR connections, or the continuous cell transfer rate for CBR connections. SCR defines the sustained cell transfer rate for VBR connections that may fluctuate up to the PCR for a burst length of MBS cells. MBS is what defines the maximum number of cells in a single burst that can be transmitted above the SCR and up to the PCR in a VBR connection. SCR and MBS are not applicable to CBR connections. Valid values for MBS are 32, 50, 100, 150, and 210, and relate to the incoming packet size from the customer premises equipment.
5. After selecting the parameters for the new traffic contract, select **Apply** using the left mouse button.
  6. A completion window appears stating the Traffic contract was created successfully. The contract name will be displayed in this window. Refer to Figure 709-3. Select **OK**.
  7. If the contract name is already in use, the message window shown in Figure 709-4 will appear.

### Delete a Traffic Contract

8. To delete an existing traffic contract, access the Traffic Contract window per step 1. Select a contract by single clicking the left mouse button with the cursor on the desired contract.
9. Select **Delete** at the bottom of the window.
10. A confirmation message window appears as shown in Figure 709-5. Select **OK**.

▶ **Note:** Traffic contracts cannot be removed if they are in use.

**Stop! You have completed this procedure.**

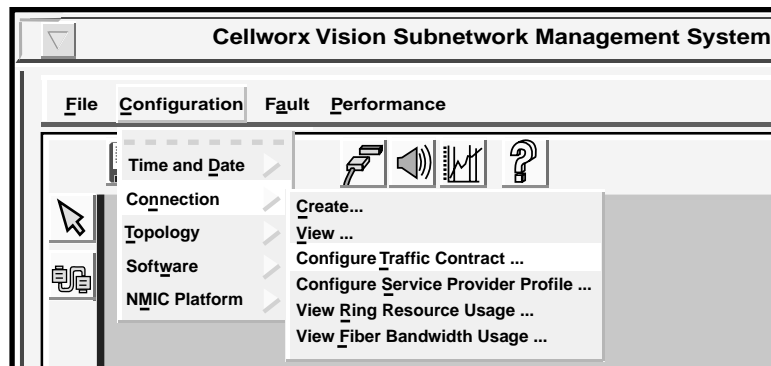

10980-D

Figure 709-1. Cellworx Vision Configure a Traffic Contract Pull Down Menu

DLP-709  
Page 3 of 4

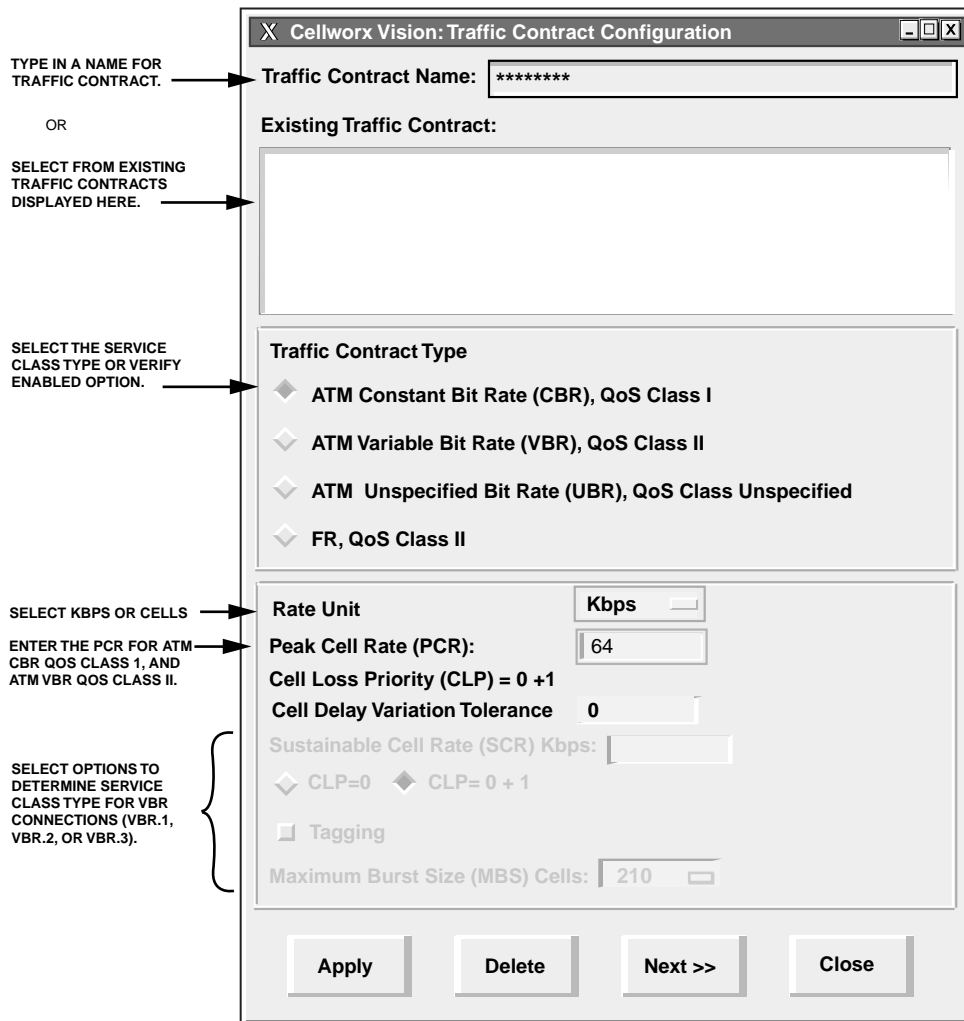

11010-E

Figure 709-2. Cellworx Vision Configure Traffic Contract Window



10937-A

Figure 709-3. Cellworx Vision Traffic Contract Configuration Completed



10954-A

Figure 709-4. Cellworx Vision Traffic Contract Already Exists Denial Message

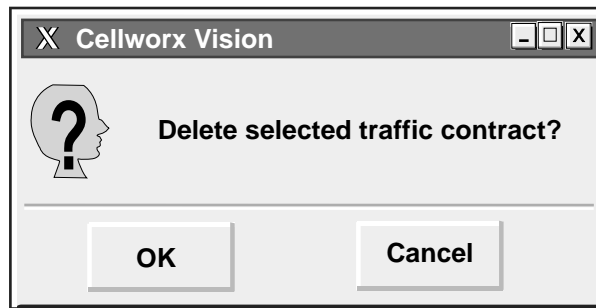

10983-A

Figure 709-5. Cellworx Vision traffic Contract Deletion Confirmation Message

**DLP-710**

Page 1 of 6

**VIEW CONNECTIONS**

**Summary:** This procedure describes the steps necessary to successfully navigate the Cellworx Vision Graphical User Interface to view the established connections. The connection information can be used for checking new connections, viewing existing connections, or to view possible connection problems on the ring. For multicast connections, refer to DLP-791.

1. Access the Subnetwork Connection Filter window using one of the following methods:
  - a. Using the left mouse button, select **Configuration, Connection, and View**. Refer to Figure 710-1.
  - b. Using the direct selection keys, enter **Alt+C, Alt+N** then **Alt+V**. Refer to Figure 710-1.
  - c. Using the right mouse button, position the cursor over the NE, click and hold the button, select **View Connections**, and release the button.
  - d. Using the left mouse button, select the connection icon above the workspace.
2. The Subnetwork Connection Filter window appears. Refer to Figure 710-2. Select a topic to filter information from using the folder tabs shown. These topics allow the user to retrieve only the information desired by **Connection** type, **Network** available, **Traffic** contract, or **ATM** traffic by port. The user may also specify all of these by using the **All** checkbox. Refer to Table 710-1 for descriptions of each filter type.
3. Once the desired information is selected, select **Apply** using the left mouse button.
4. The Subnetwork Connections window appears as shown in the example in Figure 710-3. The information can be displayed alphabetically by the connection name or by the NE name by using the **Filter** pull down menu. The status column indicates the most current information for the connection. The status may be listed as **INCOMPLETE**, **FUNCTIONAL**, or as an **UNKNOWN STATE**. This screen displays up to 100 entries per page by using the up and down slide button on the right side of the window. If more than 100 entries are available for viewing, the user may use the Page slide button at the top right corner of the window to select additional pages.
5. If a connection is displayed as **INCOMPLETE**, the user may select it and then select **Retry** to attempt to establish the connection.
6. The user may delete a connection, or multiple connections, by selecting them using the left mouse button, and then selecting **Delete**. A confirmation message will appear as shown in Figure 710-4 which requires the user to select **OK** or **Cancel**. If a problem exists with the hardware between the NMIC and the endpoints shelf controllers, a denial message may appear detailing why the connection could not be deleted. Refer to DLP-713 and the trouble log for any error reports.



7. To gain status information of a certain connection, the user double clicks on the connection using the left mouse button, or single clicks to highlight the connection followed by selecting **Status** at the bottom left of the window.
8. The Subnetwork Connection Status window appears. Refer to Figure 710-5. The connection name is displayed at the top of the window. The administrative state may show as Locked or Unlocked. Locked indicates the connection is taken down at both ends, no traffic is allowed on the ring. Unlocked indicates the connection is operable in a normal state. The user may change options on the connection by selecting **Configure**. Access to the Configure screen can also be obtained from the previous Subnetwork Connection screen via the **Configure** selection button.
9. The Subnetwork Connection Configuration screen appears. Refer to Figure 710-6. Again the connection name is displayed at the top of the window. The connection can be taken down by changing the Administrative State to **Locked** using the button at the top right corner of the window and then selecting **Apply**.
10. The administrator can configure either or both ends of the connection as OAM cell segment endpoints by selecting the Segment Endpoint box displayed at each end of the connection. This functionality can be used for maintenance or troubleshooting purposes. Select **Apply** to send configuration changes to the database or close to abort any changes.
11. Depending on what type of connection was selected, certain fields may be grayed out and not configurable. For options available for subnetwork connection configurations, refer to Table 710-2.
12. The configuration change completed window appears. Select **OK**.

**Stop! You have completed this procedure.**

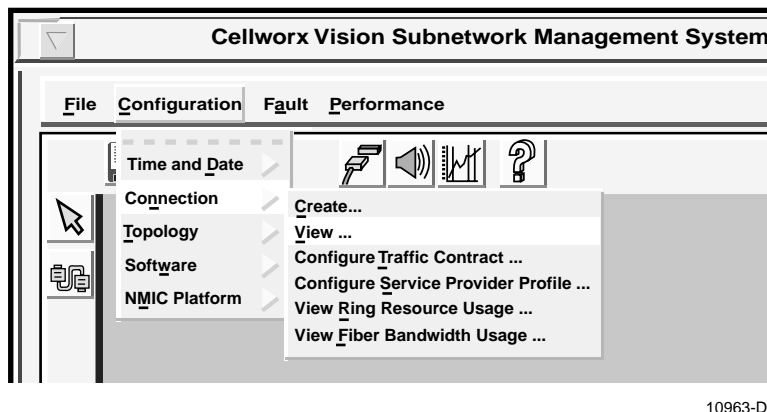

10963-D

Figure 710-1. Cellworx Vision Connection Menu Tree

DLP-710  
Page 3 of 6

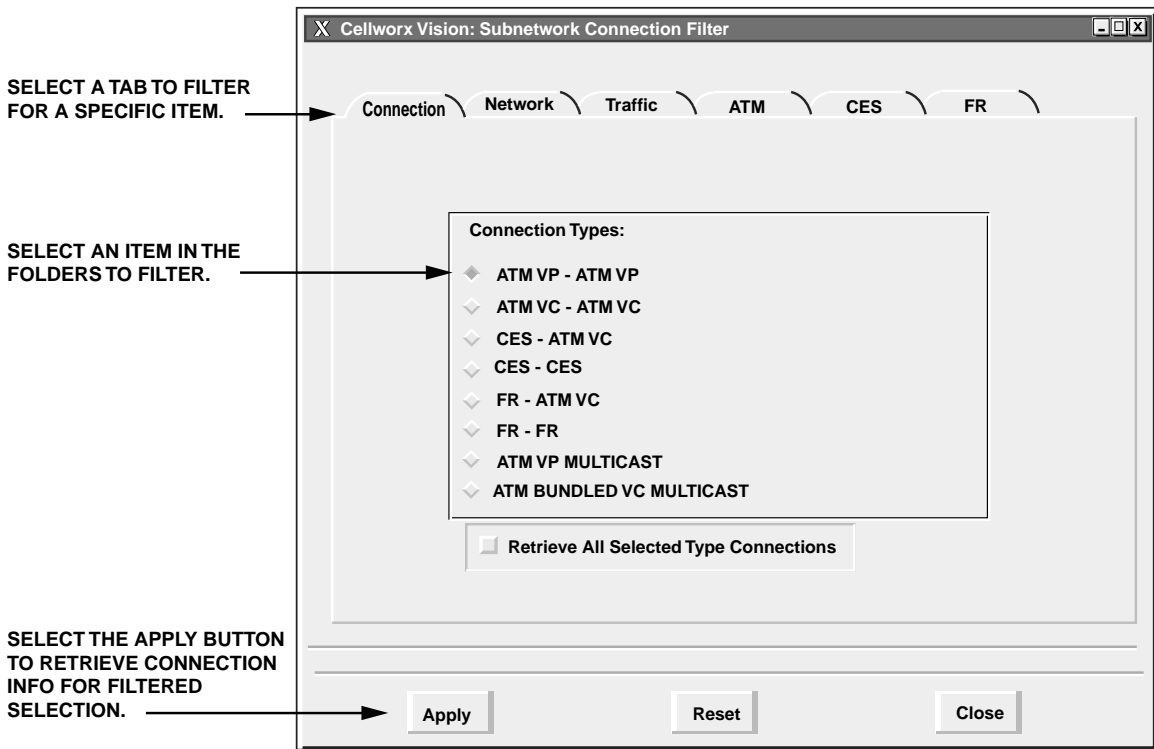

11000-F

Figure 710-2. Subnetwork Connection Filter Window

Table 710-1. Cellworx Vision Subnetwork Connection Filter Descriptions

FILTER TYPE	OPTIONS	DESCRIPTION
Connection	ATM VP - ATM VP	Selects all ATM VP connections.
	ATM VC - ATM VC	Selects all ATM VC connections.
	CES - VC	Selects all Circuit Emulation Service to ATM Virtual Channel connections.
	CES - CES	Selects all Circuit Emulation Service connections (Phase II).
	FR-ATM VC FR-FR	Frame Relay not supported for Release 3.1 software packages.
	ATM VP Multicast	Selects all virtual path connections that have multiple endpoints associated with them.
	ATM Bundled VC Multicast	Selects all virtual path connections that have multiple endpoints associated with them and bundled virtual circuits contained in the path.
Network	Administrator defined.	Allows user to specify certain NEs when filtering connections.

(continued)

Table 710-1. Cellworx Vision Subnetwork Connection Filter Descriptions, continued

FILTER TYPE	OPTIONS	DESCRIPTION
Traffic	Administrator defined.	Selects the traffic contract to be queried. These are user-defined names. Several connections may utilize the same traffic contract.
ATM	Administrator defined.	Selects the UNI or NNI to be queried. These are user-defined names and apply to specific ports.
FR	Administrator defined.	Selects the frame relay UNI to be queried. These are user-defined names and apply to specific ports.

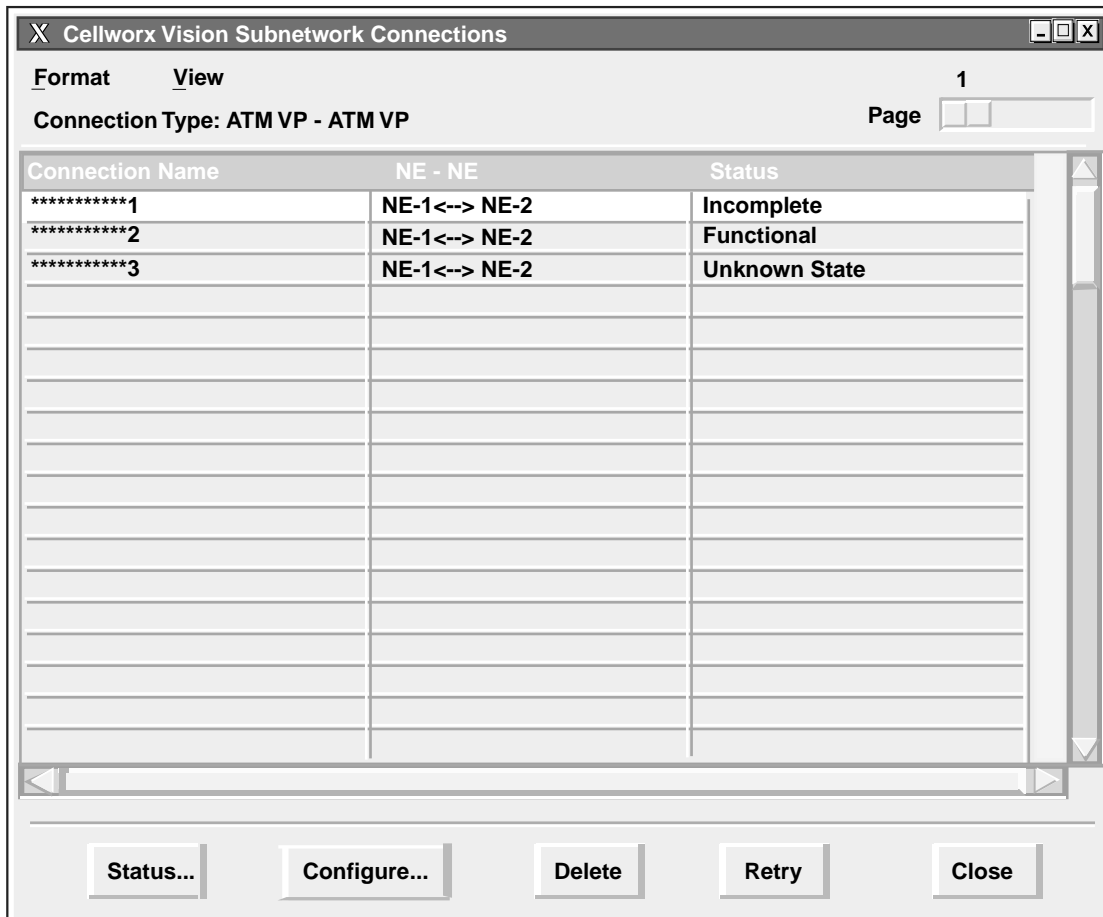

11003-B

Figure 710-3. Cellworx Vision Subnetwork Connections Screen



10982-A

Figure 710-4. Cellworx Vision Connection Deletion Confirmation Window

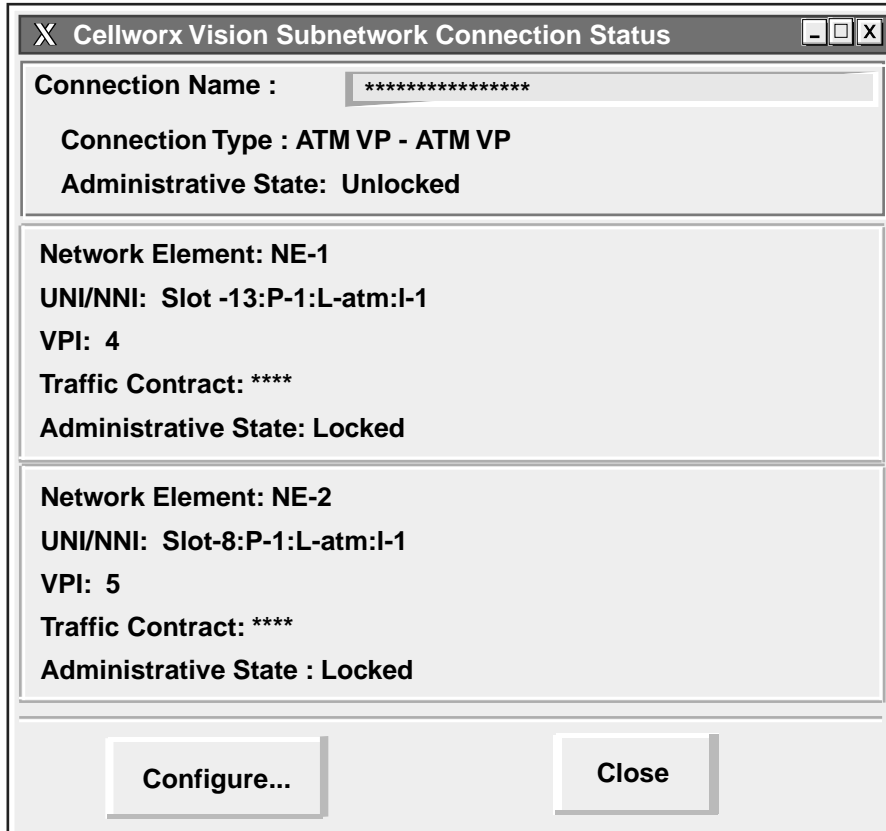

11001-C

Figure 710-5. Cellworx Vision Subnetwork Connection Status Window

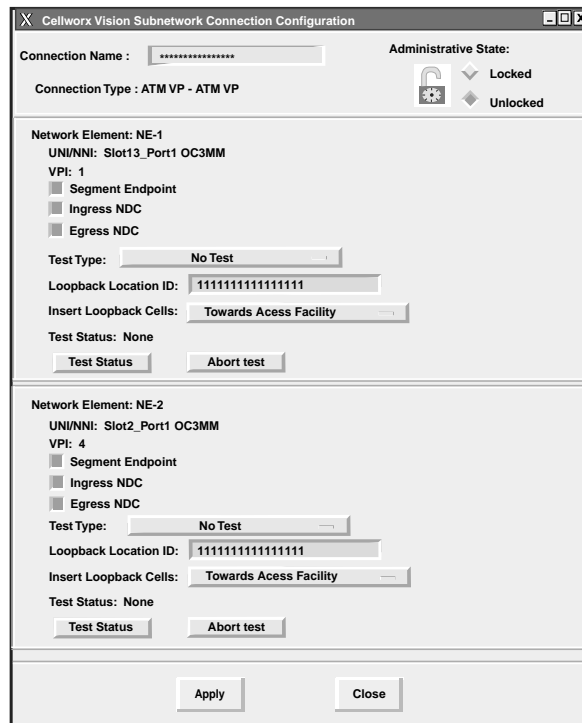

10995-B

Figure 710-6. Cellworx Vision Subnetwork Connection Configuration Window

Table 710-2. Sub-network Connection Configuration Options

SELECTION	OPTIONS	DESCRIPTION
Segment Endpoint	Single selection box	Sets this end of the connection as a segment endpoint for OAM cells.
Ingress / Egress NDC	On or Off	Enables or disables the network data collection for selected circuit.
Test Type	End to End OAM Segment OAM Continuity Check Source Continuity Check Sync No Test	No test is currently being administered.
Loopback Location ID	Customer assigned	Used to loopback the incoming signal and transmit it back to the customer equipment. The code is limited to 16 numeric characters.
Insert Loopback Cells	Towards Access Facility Towards Ring Facility	Defines the direction for the cells to be transmitted.
Test Status	None Active	Test is not currently active. Test is currently in progress.

DLP-711  
Page 1 of 1

## LOG OFF OF CELLWORX STN GRAPHICAL USER INTERFACE

**Summary:** This procedure outlines the steps required to log off of the Cellworx STN GUI.

1. Select the **File** pull down menu at the top of the screen using the mouse or **Alt+F** on the keyboard. Refer to Figure 711-1.
2. Select **Exit** using the mouse or the **Alt+X** keys. The user may also select the door icon next to the disk on the tool bar to exit.
3. If the icons were rearranged (redrawn) during the logon session, a “Save icon before exiting?” window appears. Refer to Figure 711-2. Select **Yes**. The software updates the latest icon coordinates and exits the GUI session, otherwise, the Exit Cellworx confirmation window appears. Refer to Figure 711-3. Select **Yes** to exit.

**Stop! You have completed this procedure.**

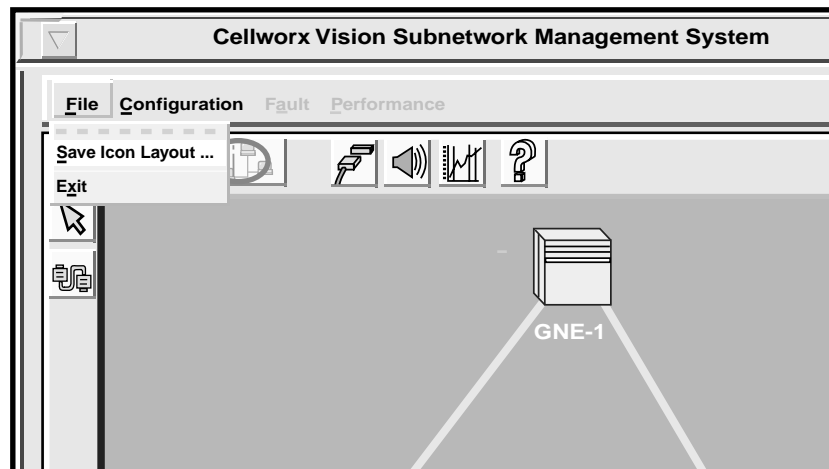

10920-C

Figure 711-1. Cellworx Vision File Pull Down Menu

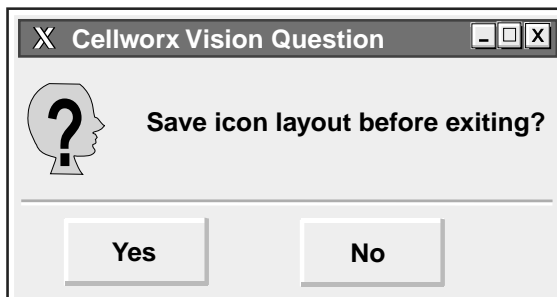

10985-C

Figure 711-2. Save Icon Coordinates

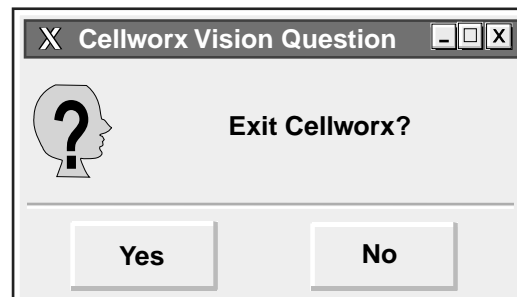

10984-C

Figure 711-3. Exit Confirmation Menu

## ADD EXPANSION SHELVES (STN-EPS)

**Summary:** This procedure describes the steps required to successfully add Cellworx STN expansion nodes (STN-EPSs) into an existing the network. These nodes are referred to as secondary nodes and are connected to primary nodes to expand access capabilities. This procedure assumes the user has gained access to and launched the Graphical User interface (GUI), and the primary NEs and fiber fragments have been discovered. Prerequisites to system Turn-up are as follows:

- The user must have accessed the system and launched the Cellworx STN GUI.
- All nodes in the network must have fibers connected, and have been powered on.
- All nodes in the network must have the working SC EIM shelf address set for individual identification (Refer to the Installation Manual listed in the preface of this document.)
- The EPS node must have the shelf type set properly. Refer to the installation manual listed in the preface of this document.

► **Note:** User may use the mouse to navigate through the GUI menus or by using the Alt + the underlined letters in the menus and then the arrow keys to scroll up down or across. Refer to the Graphical User Interface Operation in Section 2 of this document.

1. Using the left mouse button, select *Configuration, Topology, and Add Expansion Shelf Network Element* (or using the direct selection keys, *Alt+C, Alt+T* then *Alt+E*). Refer to Figure 712-1.
2. The Add EPS NE Task Overview window appears. Refer to Figure 712-2. This window keeps the user informed of the progress of adding the STN-EPS shelf. During certain tasks (indicated in process by the pointing finger), a dialog window will appear requesting certain information. First, during task number one, the Add EPS NE-Enter Identifier window appears as shown in Figure 712-3. Using the left mouse button, click, hold, and drag the slide bar to select the ring node ID that the EPS is connected to. Then do the same on the Expansion node slide bar to select the EPS shelf ID number. Valid values are 1 through 50 and should reflect the IDs set via the rotary switches on the protect SC EIM card at the rear of the shelf. Refer to the Installation Manual listed in the preface of this document for more information on setting shelf Ids. Select *Next>>* to continue with the next task. A check box on the task overview window indicates that the tasks are completed.
3. A second dialog window titled Add EPS NE - Enter Slots/Ports, appears for task number two. Refer to Figure 712-4. Type in the slot and port numbers for the ring node that correspond to the card and port used to link the STN-EPS shelf. The Tab key may be used to move between the fields. Next enter the slot and port numbers for the STN-EPS shelf that correspond to the card and port used to link to the ring node. The EPS must use port 1 of the SEPICs (Shelf ExPansion Interface Cards). Select *Next>>* to continue. If there are any problems, the error message shown in Figure 712-5 will appear. Click on *Retry* to reattempt the discovery or *Abort* to stop this process.

**DLP-712**

Page 2 of 8

4. A status window pops up stating that the NMIC is verifying the RNE slot is configured as a SEPI (Shelf Expansion Interface), and to please wait. If the slot is not configured as a SEPI, another pop up window appears prompting the user to select another slot. If this happens, verify slot configuration on the shelf and change if necessary, or select another slot, otherwise continue.
5. The Add EPS NE - Connect to Ring window appears. Refer to Figure 712-6. Verify that the STN-EPS shelf has physically been connected to the ring node and select *Next>>*.
6. The Add EPS NE - Wait for Boot-up window appears. Refer to Figure 712-7. The STN-EPS generally boots up within five minutes if it is properly connected to the ring node. At this time the user may abort the task by selecting *Cancel*. If the boot-up exceeds five minutes, the Add NE Boot Time Exceeded window appears. Refer to Figure 712-8. Follow the instructions and select either *Quit* or *Retry*. If Quit is selected, the Add NE - Reconnect Cables window appears. Refer to Figure 712-9. Follow the instructions to return the equipment to its original physical state and select *OK*.
7. After the EPS boots successfully, there may be several popup windows that appear briefly asking the user to wait while processing. The system verifies the shelf and interface type during this process. The Configure Software – Network Elements window appears for task number 9, displaying the cards equipped in each slot of the shelf, and the current running software versions. Refer to Figure 712-10. Software installation is recommended but not necessary. Select *Skip SW Installation* and go to step 12. To install the software, continue.
8. To install software for each card type in the shelf (except SC), select and hold the right mouse button on the row of the card. A pop-up window appears displaying any images that are stored on the NMIC for the card.
9. Select a software version displayed in the pop-up window and release the mouse button. The version is now listed in the Selected Software Image column on the right.
10. Repeat the software image selection for each card. Once all new images have been chosen, select *Apply*. Selecting *Apply* before choosing software images brings up the instructional window shown in Figure 712-11. Selecting the *Clear Selected* button will reset all selected software images leaving the second column from the right blank. *Refresh* can be selected periodically to update all information in the window. Selecting *Skip* will close the window and no software versions will be changed.
11. Once the software images have been selected for download, a confirmation pop-up window appears. Refer to Figure 712-12. Select *OK* to continue adding an EPS NE. Once completed the Continue button becomes selectable. Select the *Continue* button.
12. A message window appears stating that the EPS shelf has successfully been added to the network and to wait while the system updates its topology. Once completed, the GUI screen will change the NE icon to reflect a primary node with expansions. Refer to Figure 712-13. The number of secondary STN-EPS shelves that may be linked to a primary ring node is



limited only by the number of ports in the RNE and the 50 node limit per network. Repeat this procedure for each STN-EPS shelf that needs to be added to the ring.

**Stop! You have completed this procedure.**

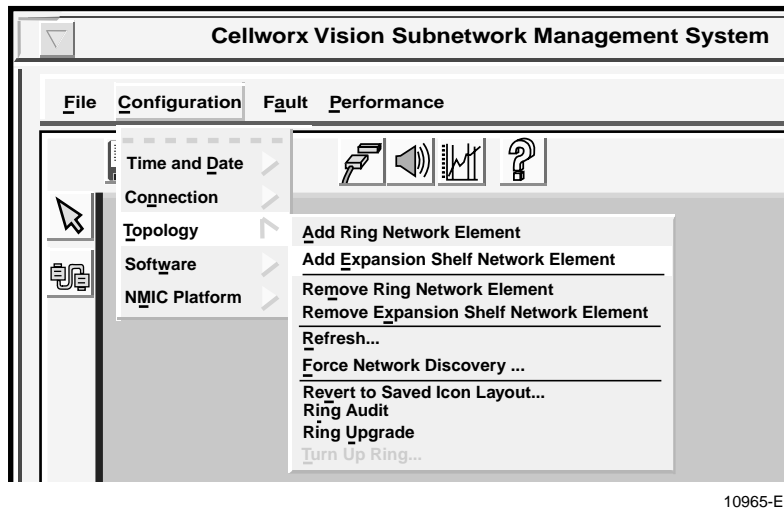

10965-E

Figure 712-1. Cellworx Vision Add an Expansion Node Pull Down Menu

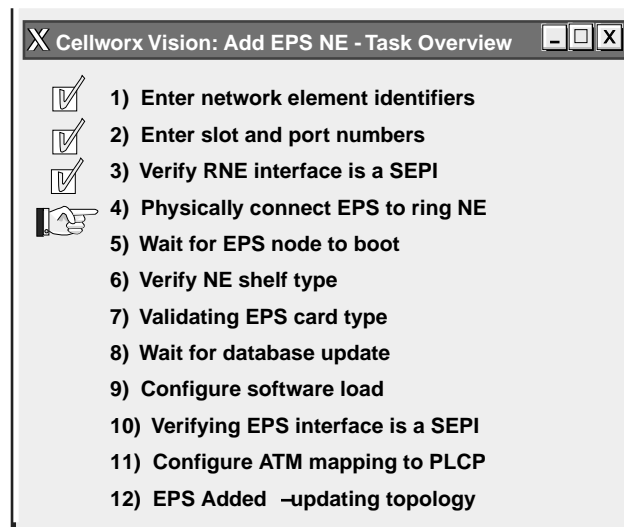

10891-E

Figure 712-2. Cellworx Vision Adding an STN-EPS Task Overview Window

DLP-712  
Page 4 of 8

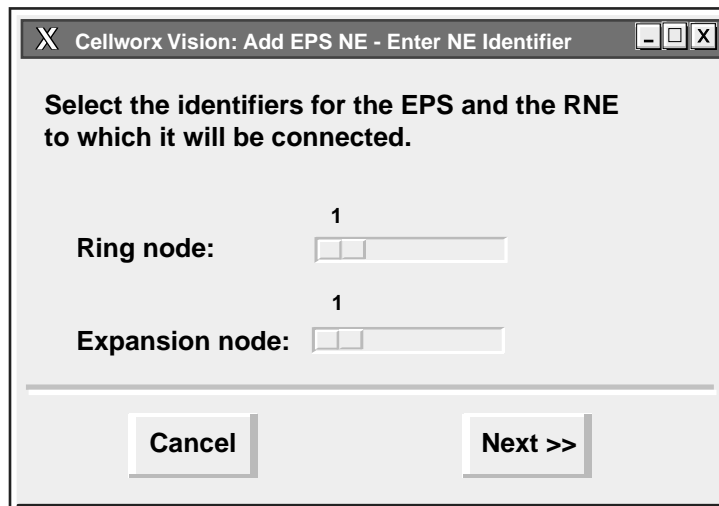

10890-E

Figure 712-3. Cellworx Vision Adding an STN-EPS ID Window

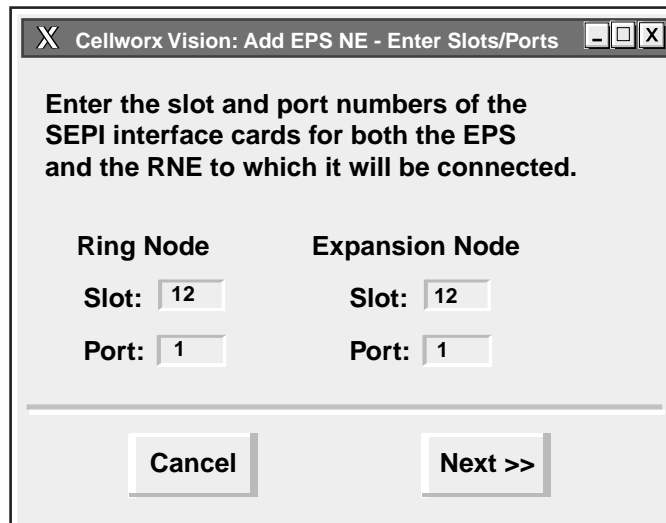

10893-B

Figure 712-4. Cellworx Vision Add EPS NE - Enter Slots/Ports

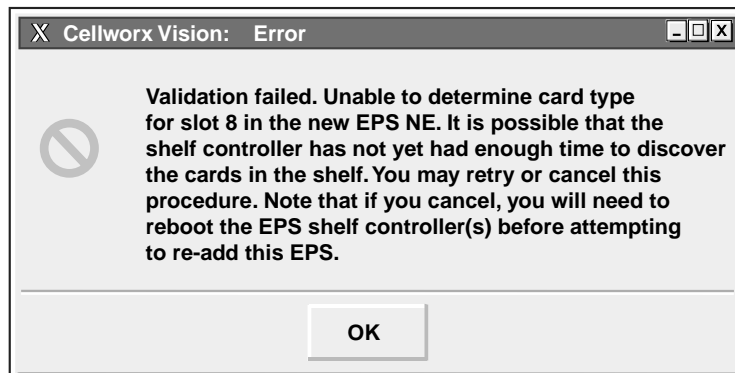

0026-055

Figure 712-5. Add EPS NE Error Message



10889-A

Figure 712-6. Cellworx Vision Add EPS NE - Connect to Ring

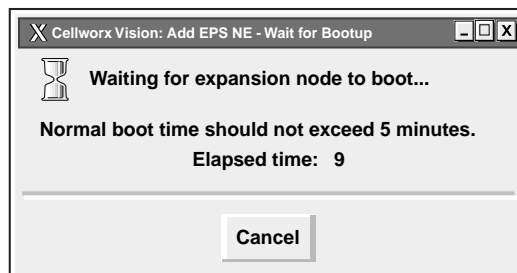

10895-B

Figure 712-7. Cellworx Vision Add EPS NE - Wait for Bootup

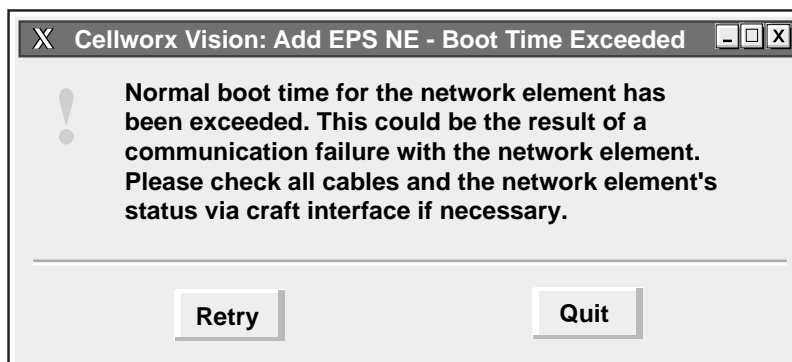

10888-A

Figure 712-8. Add NE Boot Time Exceeded Window



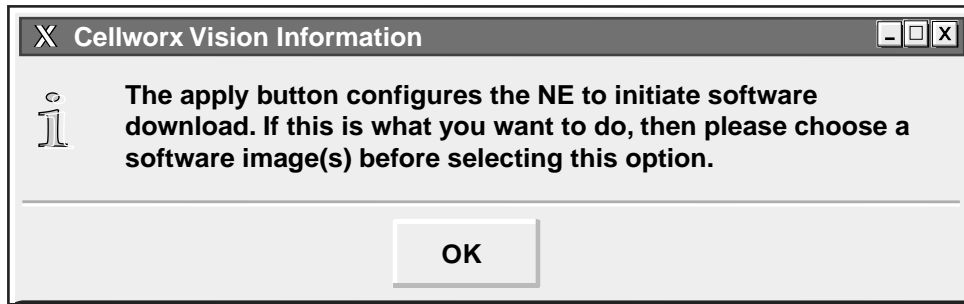

10933-B

Figure 712-11. Cellworx Vision Software Selection Instructional Window

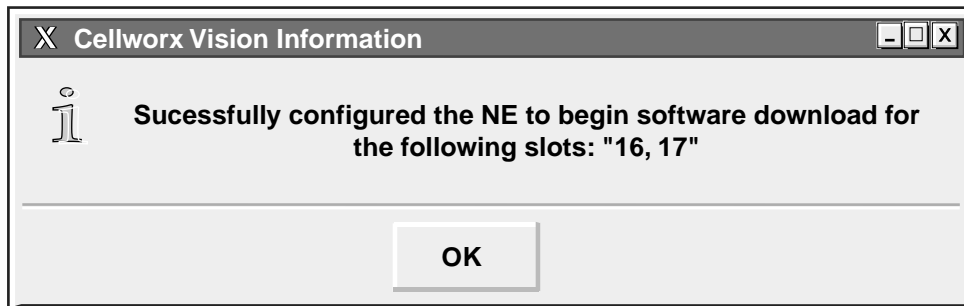

10934-C

Figure 712-12. Cellworx Vision Successful Software Image Download Message

# DLP-712

Page 8 of 8

ICON FOR NE-2 INDICATES  
THE PRESENCE OF STN-EPS  
SHELVES

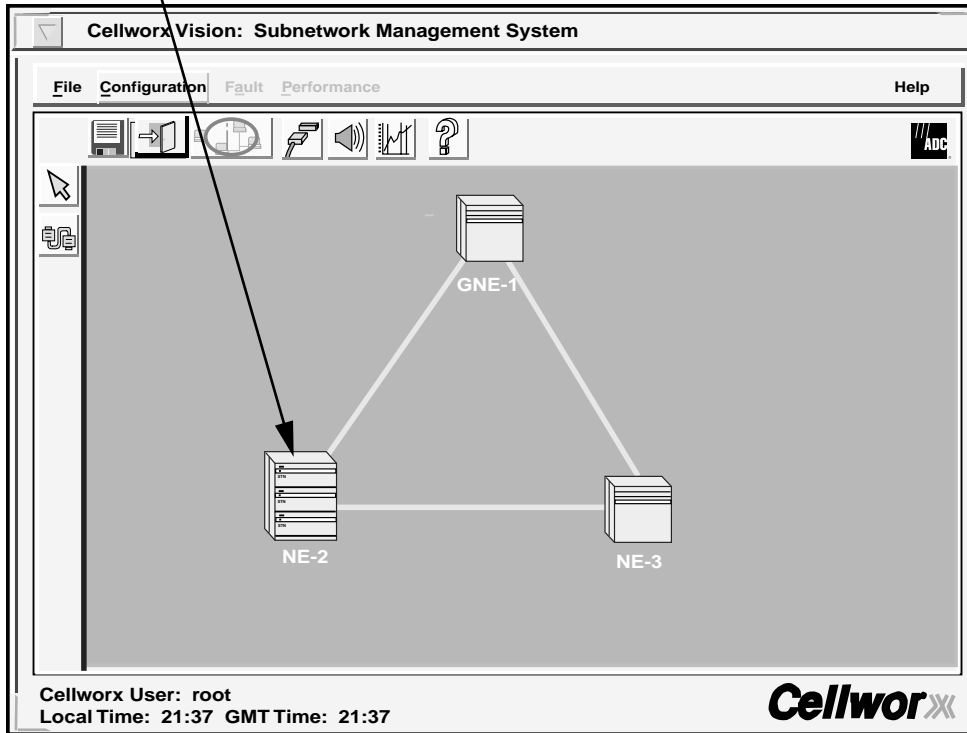

10926-D

Figure 712-13. Cellworx STN Network with a Primary Node  
Linked to at Least One Secondary STN-EPS Shelf

## DISPLAY NETWORK ALARM SUMMARY

**Summary:** This procedure provides the information necessary to successfully navigate through the Graphical User Interface (GUI) screens and retrieve a network alarm summary report. This procedure assumes the user has accessed and launched the GUI. For information on understanding the node alarm indications in the GUI display, refer to the TAP section of this document.

1. Using the left mouse button, select the **Fault** pull down menu and then **Alarms** (or hit **Alt+A** and **Alt+A**). Refer to Figure 713-1. The user may also select the alarm icon above the workspace and below the Fault pull down menu option, to access this window.
2. The Cellworx Vision Alarms window appears. Refer to Figure 713-2. Use the left mouse button to select the up or down arrow tools at the Interval (GMT) box near the top left of the screen, and select the 15 minute period alarm report to retrieve. The alarm reports can be retrieved for any completed fifteen minute period within the last 24 hours (valid values are 00:00 - 00:15 to 23:45 - 24:00). A Current selection is available to retrieve any alarms that have been generated since the current GUI session was initiated.
3. After selecting an interval, use the mouse to open the pull down menu located in the down arrow tool next to the dialog box. Select the Domain you wish to retrieve alarms from. The valid options for Domain are described in Table 713-1.
4. The user may now select **Apply** to generate the report. The alarms are displayed in chronological order under the Most Recent Unfiltered Traps section of the window.
5. To specify certain alarm types to retrieve for the report, select **Filter** at the top left corner of the window and **Configure**. There is also an option to disable the filter (**Filter Off**).
6. The Cellworx Vision Alarm Filter window appears. Refer to Figure 713-3. In the top section of the window labeled Network Elements/Ring, select the specific NEs available in the box one at a time and then select the >> button to add them to the Selected Network Elements/Ring box. The slider bars may be used to view NEs not currently visible in the box. All of the NEs may be selected at one time by selecting the **ALL>>** button. If certain NEs need to be removed from the selected Network Elements/Ring box, click on them and select the << button.
7. The second section of the window lists the resources that are available for alarm retrieval. Refer to Table 713-2 for a complete listing of all resource types. Select the desired resources for the alarm report either one at a time each followed with the >> button, or all of them by selecting the **ALL>>** button.
8. The third section of the window lists each severity available for alarm retrieval. Refer to Table 713-3 for a complete listing of all severity types. Select each desired severity for the alarm report either one at a time each followed with the >> button, or all of them by selecting the **ALL>>** button.

**DLP-713**

Page 2 of 5

10. The fourth section of the window lists generic troubles that are available for alarm retrieval. Select the desired generic troubles for the alarm report either one at a time, each followed with the >> button, or all of them by selecting the **ALL>>** button. For a complete listing of alarms, refer to Section 4, Troubleshooting Guidelines.
11. Once the alarm filter has been customized to retrieve the alarms desired, select the **Apply** button to save the changes or select **Close** to abort any changes and close the screen.
12. The selected alarms for the 15-minute time specified in the Interval (GMT) dialog box are displayed in chronological order under the Filtered Traps section of the window. Refer to Figure 713-2. For a list of GUI alarms and troubleshooting tips, refer to the TAP section of this document.

**Stop! You have completed this procedure.**

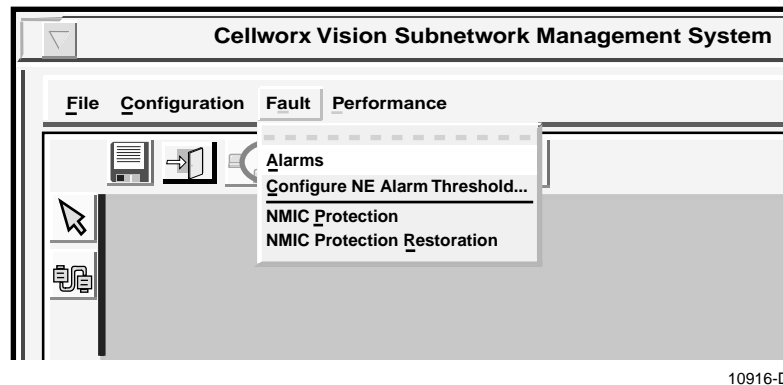

Figure 713-1. Cellworx Vision Fault Pull Down Menu



SELECT A HISTORICAL INTERVAL OR CURRENT DATA. SELECT A DOMAIN FROM LIST. THEN HIT APPLY TO RETRIEVE ALARM LIST.

UP TO 1000 FILTERED TRAPS ARE DISPLAYED IN THIS BOX. SELECT PAGES 1 TO 10, EACH DISPLAYING UP TO 100 ALARMS.

USE THE SLIDE BARS TO SCROLL THROUGH THE FILTERED ALARMS.

THE LAST 10 UNFILTERED TRAPS ARE DISPLAYED HERE.

A TOTAL COUNT OF EACH ALARM IS DISPLAYED BY SEVERITY.

The screenshot shows a window titled "Cellworx Vision Alarms" with a "Filter" section containing "Interval (GMT): 00:00 - 00:15" and "Domain: Ring". Below this is a "Filtered Traps" table with columns for Severity, Date/Time, Network Element/Ring, Resource, and Generic Trouble. A "Most Recent Unfiltered Traps" table is also present. At the bottom, there are counters for Critical (0), Major (0), Minor (0), International (0), and Cleared (0) alarms, along with "Close" and "Clear Alarm Log" buttons.

10900-C

Figure 713-2. Cellworx Vision Alarms Screen

Table 713-1. Cellworx Vision Alarm Domain List

DOMAIN	DESCRIPTION
Ring	Contains 96 15-minute logs for any ring level alarms.
NMIC	Contains 96 15-minute logs for any NMIC level alarms (i.e., database full, etc.)
NE #	Contains 96 15-minute logs for any NE level alarms. All NEs discovered on the ring are listed and selectable under Domain.

DLP-713  
Page 4 of 5

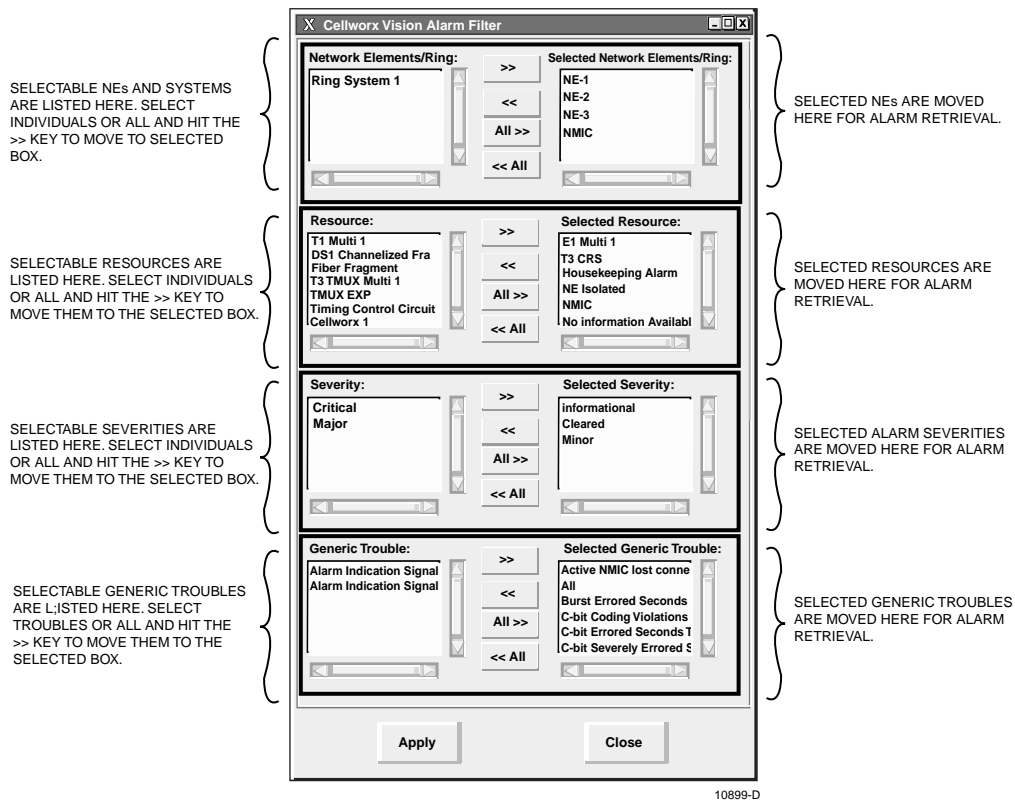

Figure 713-3. Cellworx Vision Alarm Filter Window

Table 713-2. Cellworx Vision Alarm Filter Resource List

RESOURCE	DESCRIPTION
155 MM or SM CRS	Selects alarms for an OC3 resource.
155 Ring, 622 Ring, 2488 Ring	Selects the alarms for a Ring Interface Card.
E1 Multi 1 or T1 Multi 1	Selects the alarms for selected card type.
Protection Groups	Selects alarms related to card protection.
T3 CRS, T3 TMUX, TMUX EXP	Selects alarms for the T3 cards.
Shelf Controller	Selects alarms related to SC modules.
Ring	Selects alarms related to the ring network.
<user defined NE Name>	Selects alarms on a particular NE(s).
Fiber Fragment	Selects alarms for the Fiber Fragment.
Housekeeping Alarm	Selects alarms for the Housekeeping Alarm.
NE Isolated	Selects alarms for the NE Isolated.
NMIC	Selects alarms for the NMIC.
No Information Available	Selects alarms that do not have enough information available to define.
Timing Control Circuit	Selects alarms related to the system timing.

Table 713-3. Cellworx Vision Alarm Filter Severity List

SEVERITY	DESCRIPTION
Critical	Severe alarms that can or do affect service and need immediate attention.
Major	Alarms that can affect service and should be addressed as soon as possible.
Minor	Alarms that are not service affecting and may be addressed during maintenance periods.
Cleared	Alarms that have cleared and returned to a normal state.
Informational	Alerts to make the administrator aware of a potential problem.

➤ **Note:** Refer to Section 4 for a complete listing of alarm types.

**DLP-714**

Page 1 of 3

**CONFIGURE SERVICE PROVIDER PROFILE**

**Summary:** This procedure details the steps required to successfully configure a service provider profile for port level connections using the NMIC GUI. Service provider profiles provide identification for each connection for account management purposes. These service provider profiles differ from those set in the connection configuration screens which identify the endpoint providers. This procedure assumes the administrator has accessed and launched the NMIC GUI per DLP-705.

1. Using the left mouse button, select *Configuration, Connection, and Configure Service Provider Profile* or use the *Alt+C, Alt+N* and *Alt+S* keys. Refer to Figure 714-1.
2. The Service Provider Profile Configuration window appears. Refer to Figure 714-2.
3. All NEs discovered will be displayed in the box under the Network Element heading. Using the left mouse button, select the network element desired for the profile
3. Select the physical interface desired for the profile under the Interface heading. These are displayed by slot number, port number, and interface type.
4. Recording Interface Identifier is then displayed in a read only field below the selections. Below that is the Carrier Identifier field. Single click on the *Carrier Identifier* field and enter a carrier identification for the selected interface using any numeric characters.
5. Single click on the *Transit Identifier* field and enter a transit identification for the selected interface using any numeric characters.
6. Select a service type from the options listed in the *Service Type* field. To view the options available, single click on the down arrow to the right of the field. A pull down list appears displaying any options configured. Refer to Figure 714-2.
7. Select a call type from the options listed in the *Call Type* field. To view the options available, single click on the down arrow to the right of the field. Refer to Figure 714-3.
8. Specify whether the remote interface is a UNI or B-ICI by a single point and click on either option under *Remote Interface Type*.
9. Select *Apply* to send the new information to the database. The system responds with the window shown in Figure 714-4. Select "*OK*" to dismiss the window.

**Stop! You have completed this procedure.**

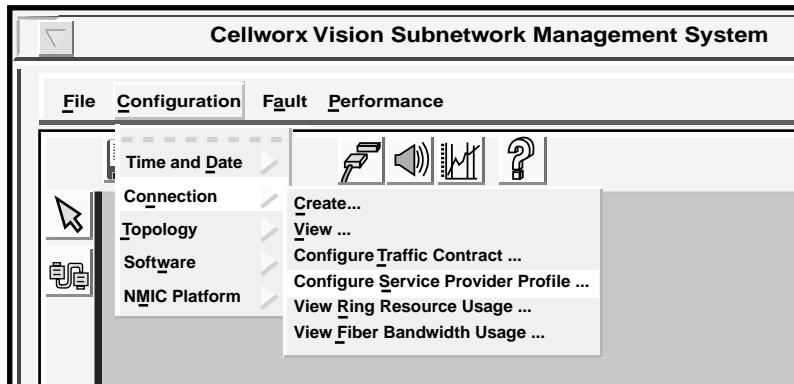

10979-D

Figure 714-1. Cellworx Vision Configure Service Provider Profile Menu

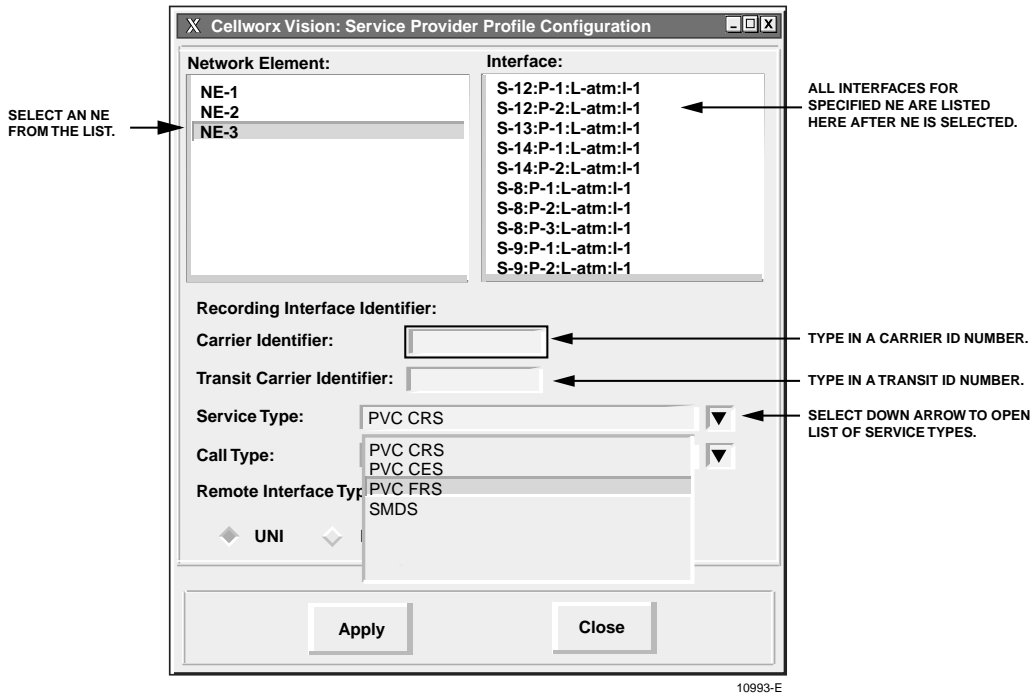

10993-E

Figure 714-2. Cellworx Vision Service Provider Profile Configuration Window

DLP-714  
Page 3 of 3

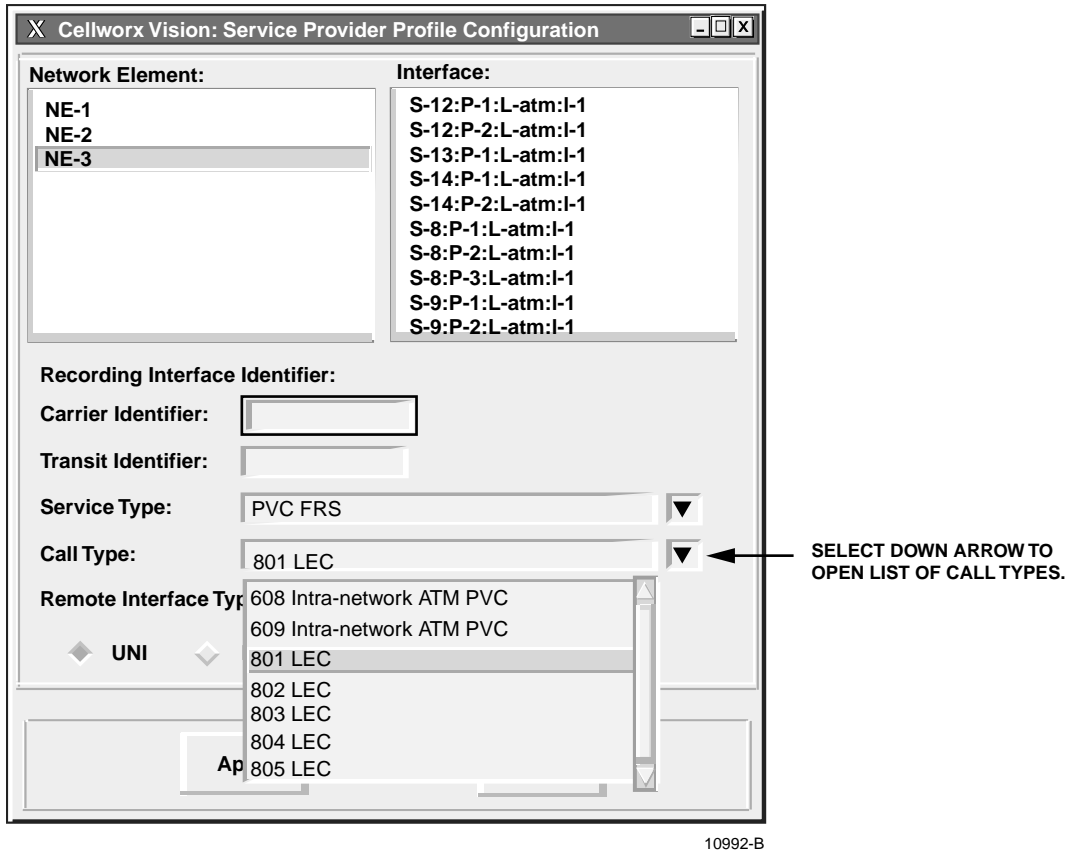

Figure 714-3. Cellworx Vision Service Provider Call Type Pull Down Menu

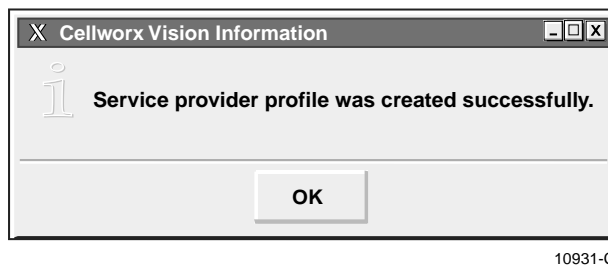

Figure 714-4. Cellworx Vision Service Provider Profile Created Confirmation

## VIEW RING RESOURCE USAGE

**Summary:** This procedure details the steps required to successfully utilize the NMIC GUI software to view the used bandwidth on a network. This procedure can be used to check for available bandwidth when assigning new connections. This procedure assumes the administrator has successfully accessed and launched the NMIC GUI software per NTP-015.

1. Using the left mouse button, select *Configuration*, *Connection*, and *View Ring Resource Usage*, (or using the direct selection keys, *Alt+C*, *Alt+N*, then *Alt+R*). Refer to Figure 715-1.
2. The Cellworx Vision Ring Resource Usage window appears. Refer to Figure 715-2. The information displayed lists a total of all VPIs assigned on the ring, if they are allocated as user or management connections, and the amount of VPIs left that may be assigned to the ring. Also listed is the amount of bandwidth allocated to user or management connections.
3. Select *Close* to return to the Cellworx Vision network display.

**Stop! You have completed this procedure.**

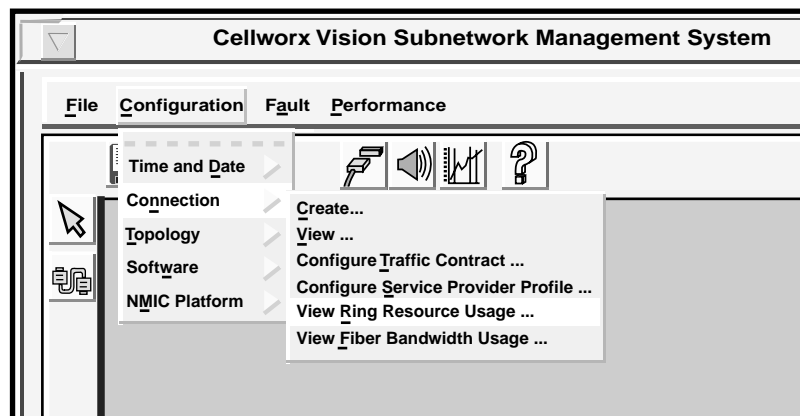

10964-D

Figure 715-1. Cellworx Vision View Ring Resource Usage Pull Down Menu

DLP-715  
Page 2 of 2

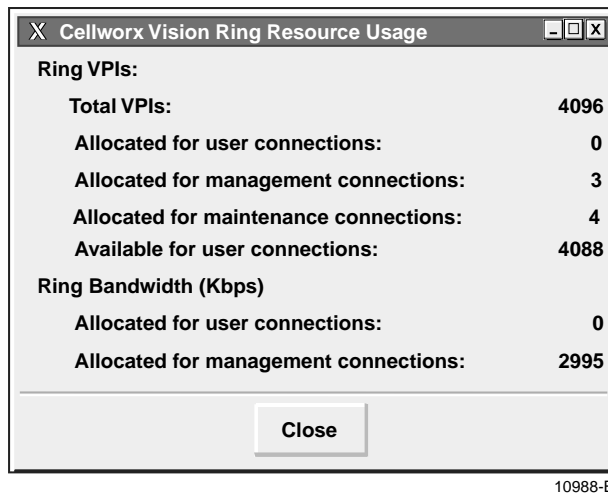

Figure 715-2. Cellworx Vision Ring Resource Usage Window



## VIEW FIBER BANDWIDTH USAGE

**Summary:** This procedure details the steps required to successfully utilize the NMIC GUI software to view the used bandwidth on a given fiber link between nodes. This procedure can be used to check for available bandwidth when assigning new connections. This procedure assumes the administrator has successfully accessed and launched the NMIC GUI software per NTP-015.

1. To view the bandwidth used between all nodes in the network, use the left mouse button to select *Configuration*, *Connection*, and *View Fiber Bandwidth Usage*, (or using the direct selection keys, *Alt+C*, *Alt+N*, then *Alt+F*). Refer to Figure 716-1.
2. The Cellworx Vision Fiber Bandwidth Usage window appears. Refer to Figure 716-2. The information displayed lists all NEs discovered on the ring, the NEs that they are connected to, and the amount of bandwidth (in Kbps) assigned between them on the ring.
3. To view the bandwidth being utilized between two individual nodes within the network, use the right mouse button and point and click on the fiber link between the two nodes. Again, the pop-up window Fiber Bandwidth Usage appears, displaying the bandwidth usage on the fiber selected between the two nodes. The values provided in this window are measured in kilobits per second (Kbps).
3. Select *Close* to return to the Cellworx Vision network display.

**Stop! You have completed this procedure.**

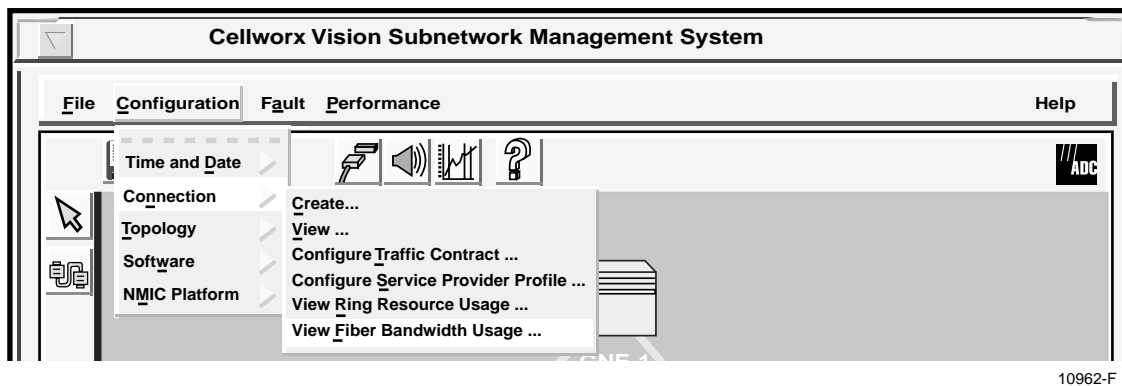

Figure 716-1. Cellworx Vision View Fiber Bandwidth Usage Pull Down Menu



## CONFIGURE NE ALARM THRESHOLD

**Summary:** This procedure describes the steps necessary to set the alarm reporting thresholds for each NE in the network. The alarm threshold setting determines the minimum alarm severity for a node to report to the GUI screen, for instance, if a node was set to Major, any minor conditions would not be reported via the GUI screen icon for that node.

1. From the GUI main screen, select **Fault** to open the pull down menu, and select **Configure NE Alarm Threshold** either using the mouse or by entering **Alt+A**, and **Alt+C**. Refer to Figure 717-1. The user may also right click on an NE and select the **Configure Threshold Alarm** option.
2. The Cellworx Alarm Threshold Configuration window appears. Refer to Figure 717-2. Select a node from the list provided under Domain.
3. Select the lowest alarm severity to be emitted from the selected node from the list provided on the right. Refer to Table 717-1 for definitions of each severity.
4. Select **Apply** to enable the new parameters. A confirmation window should appear similar to Figure 717-3. Dismiss the confirmation window by clicking **OK** and close the Alarm Threshold Configuration screen.

**Stop! You have completed this procedure.**

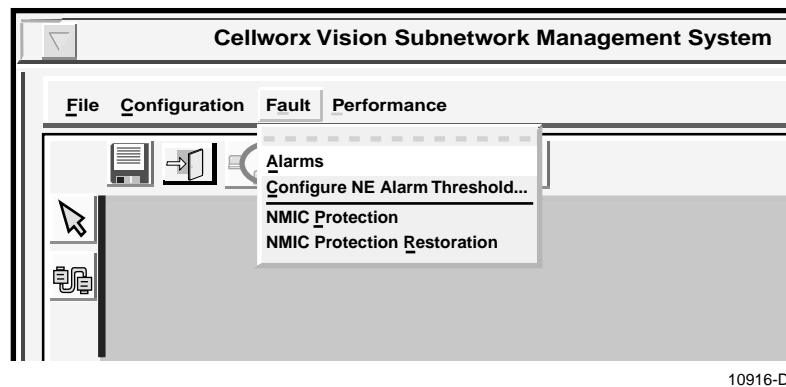
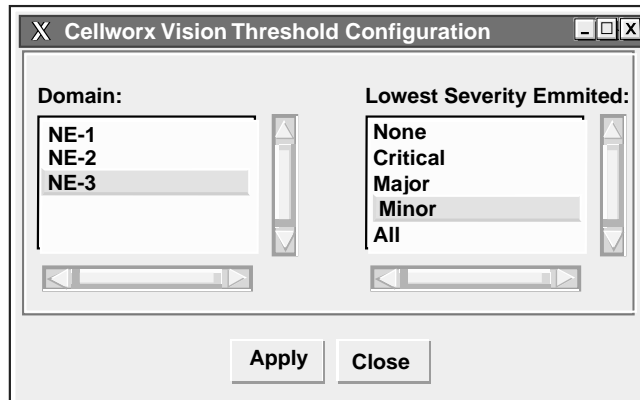

Figure 717-1. Cellworx Vision GUI Fault Pull Down Menu

Table 717-1. Alarm Severity List

ALARM SEVERITY	DEFINITION
None	No alarms will report to the X-Terminal.
Critical	Only critical alarms will be reported to the X-Terminal.
Major	Major and critical alarms will be reported to the X-Terminal.
Minor	All major, minor, and critical alarms are reported to the X-Terminal.
All	All alarms and informational alerts will be reported to the X-Terminal.



11004-B

Figure 717-2. Alarm Threshold Configuration Window

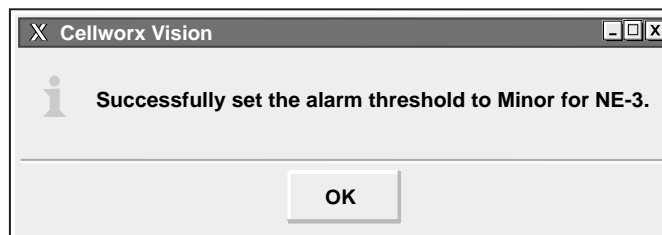

10932-A

Figure 717-3. Alarm Threshold Configuration Change Confirmation

## REFRESH TOPOLOGY

**Summary:** This procedure describes the steps required to refresh the display of the network nodes. This is done after any changes to the view of the network have been modified such as adding or deleting nodes, moving the positions of a node, changing connections between the nodes, or changing node names.

1. Select the *Configuration* pull down menu, *Topology*, and *Refresh* using the left mouse button or by hitting *Alt+C*, *Alt+T*, and *Alt+R*. Refer to Figure 718-1.
2. The system responds with a message window stating that it is updating the topology, and to please wait. Refer to Figure 718-2.
3. A refresh may also be initiated using the icon shown in Figure 718-3.

**Stop! You have completed this procedure.**

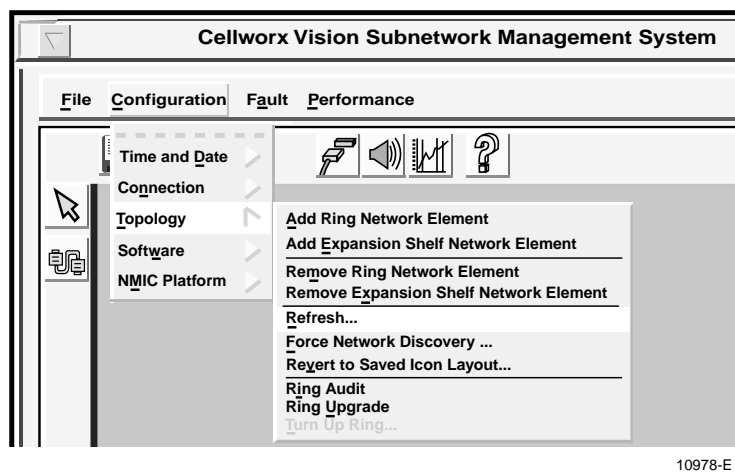

Figure 718-1. Cellworx Vision Configuration Pull Down Menu



Figure 718-2. Cellworx Vision GUI Updating Topology

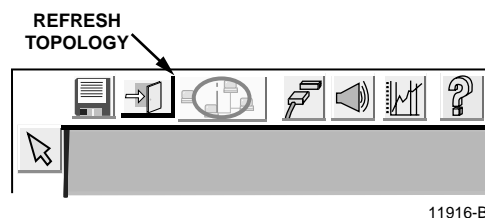

Figure 718-3. Refresh Topology Icon on NMIC GUI

**DLP-719**

Page 1 of 2

**FORCE NETWORK DISCOVERY**

**Summary:** This procedure describes the steps required to perform a forced network discovery. The forced discovery function compares the NMIC database with the physical topology to ensure the physical equipment on the ring matches what the NMIC thinks is there.

1. Select the **Configuration** pull down menu, **Topology**, and **Force Network Discovery** from the task bar by single clicking on it with the left mouse button or by hitting **Alt+C**, **Alt+T**, and **Alt+F**. Refer to Figure 719-1.
2. The system responds with a message window stating that the GUI is forcing rediscovery on the network and to please wait as shown in Figure 719-2.
3. If the system fails to force network discovery, and error message will appear as shown in Figure 719-3. The user should then verify the RIC cards are in a normal state (status LEDs are green) at each node and then return to step one of this procedure.

**Stop! You have completed this procedure.**

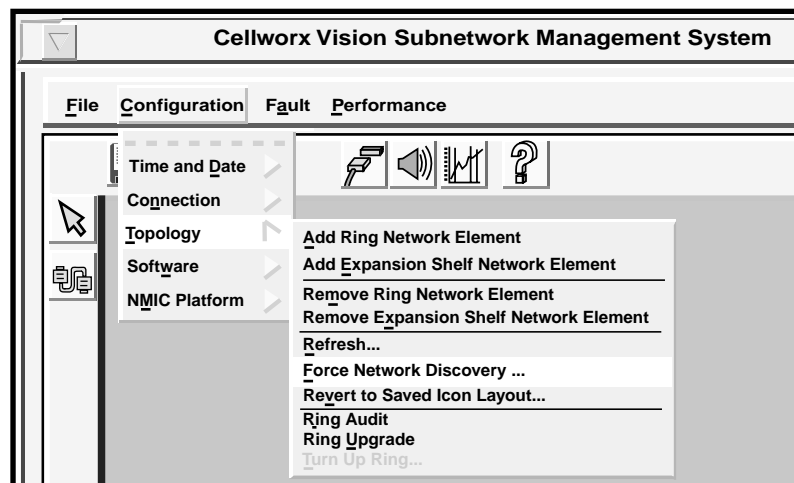

10961-E

Figure 719-1. Cellworx Vision Configuration Pull Down Menu

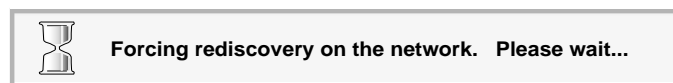

11014-A

Figure 719-2. Cellworx Vision Rediscovery Message

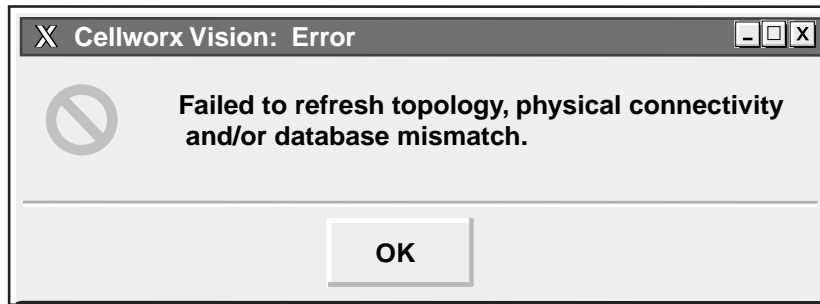

11913-B

Figure 719-3. Failure to Force Network Discovery Message Window

**DLP-720**

Page 1 of 4

**SOFTWARE SELECTION**

**Summary:** This procedure describes the steps required to successfully select the operational software version for individual card types in any given node, and initiate an upgrade or fallback to a selected software version that is compatible with the current version of the NMIC. The user should be logged on to the system and have launched the Graphical User Interface (GUI) before performing this procedure per NTP-012.

1. Select the NE that will have the software versions changed by clicking on it using the left mouse button. A ring should now encircle the NE icon. If the software screens are accessed without first selecting a node, the informational message in Figure 720-1 will appear.
2. Select the *Configuration* pull down menu, and then *Software* using the left mouse button or by hitting *Alt + C*, and then *Alt+W*. Refer to Figure 720-2.
3. The software window opens with *Configure NE* highlighted. Select it by single clicking on it using the left mouse button or by hitting *Return*.
4. The Configure Software window for the selected NE appears and displays each card equipped in the shelf, along with the current running software versions. See Figure 720-3. To change a software version for each card type in the shelf (except SC), select and hold the right mouse button on the row of the card to be changed. A pop-up window appears displaying any images for that card that are stored on the NMIC.
5. Select a software version displayed in the pop-up window and release the mouse button. The version is now listed in the Selected Software Image column on the right of the window.
6. Repeat the software image selection for each card type to be changed. Once all new images have been chosen, select *Apply*. Selecting *Apply* before choosing software images, brings up the instructional window shown in Figure 720-4. Selecting the *Clear Selected* button will reset all selected software images leaving the last column blank. *Refresh* can be selected periodically to update all information in the window. Selecting *Cancel* will close the window and no software versions will be changed.
7. Once the software images have been successfully applied, the confirmation pop-up window appears. Refer to Figure 720-5. Select *OK* and then *Close* the Configure Software window.
8. Repeat steps 1 through 7 for each NE to be changed.

**Stop! You have completed this procedure.**



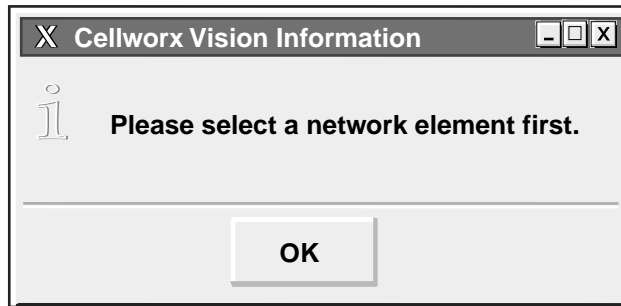

10930-C

Figure 720-1. Cellworx Vision Informational Message

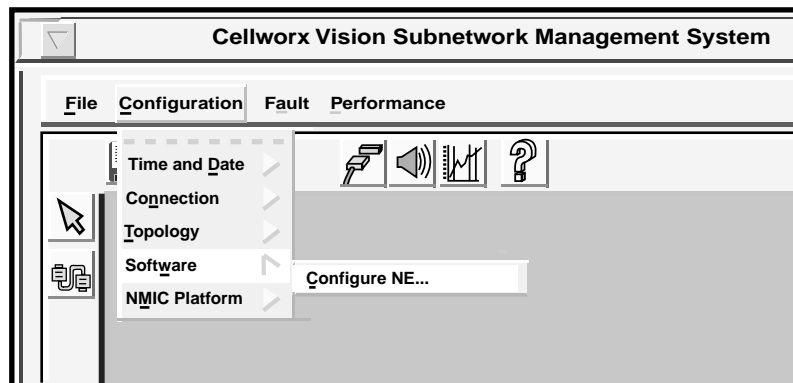

10975-E

Figure 720-2. Cellworx Vision Software Menu Tree

DLP-720  
Page 3 of 4

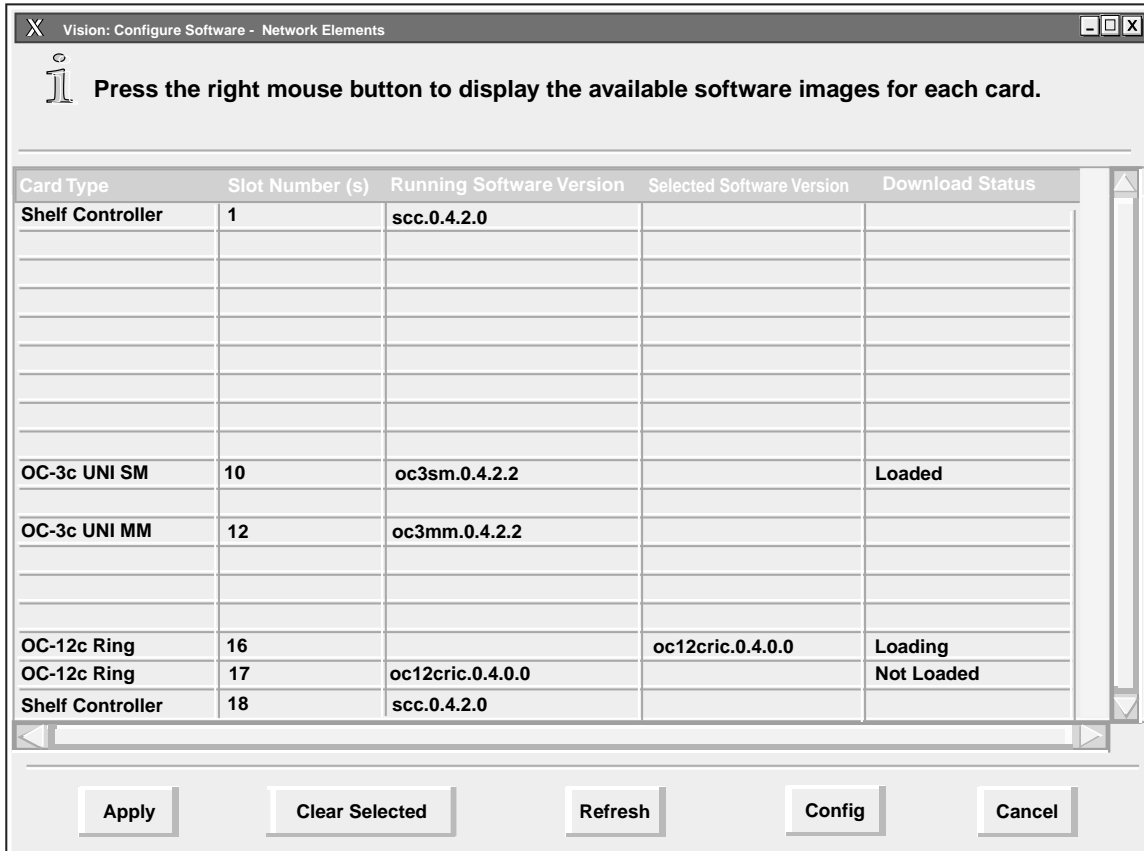

11717-C

Figure 720-3. Selecting a New Software Version

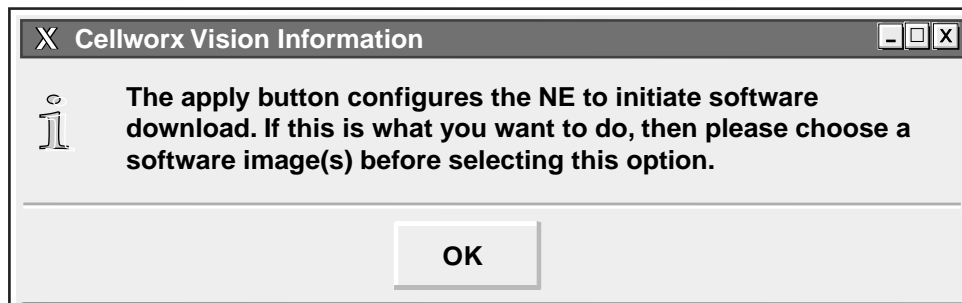

10933-B

Figure 720-4. Cellworx Vision Instructional Message

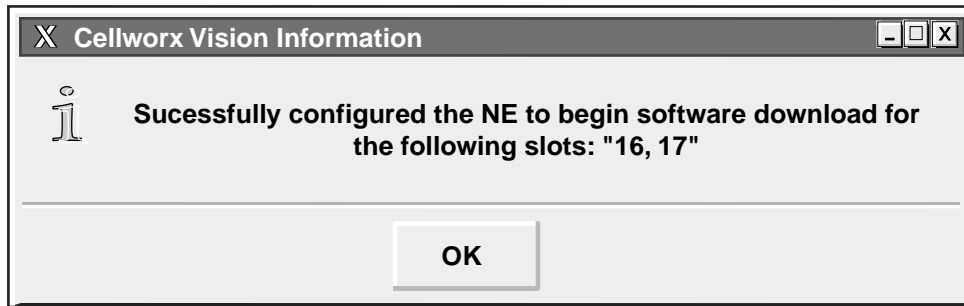

10934-C

Figure 720-5. Software Upgrade Confirmation Message

## DLP-721

Page 1 of 2

## ABOUT NE

**Summary:** This procedure details the information displayed for an NE when the user selects it, opens the pop-up menu, and chooses About.

1. Click and hold the right mouse button over the NE to open the NE pop-up menu window.
2. Select **About** located at the top of the pop-up window and release the mouse button. Refer to Figure 721-1.
3. The Network Element About window appears displaying the NE name, number, software version, the assigned vendor, the node alarm and power status, the current time, and the total time the NE has been in service. Refer to Figure 721-2.

**Stop! You have completed this procedure.**

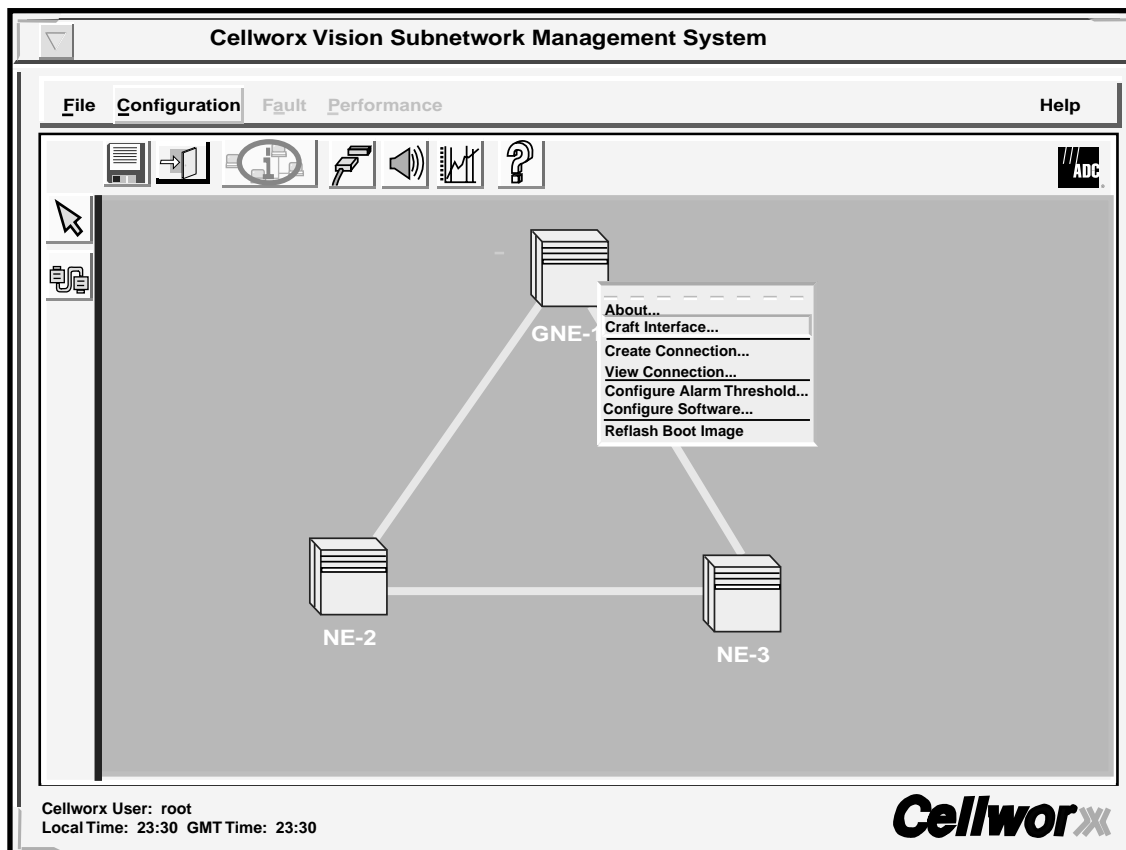

10942-F

Figure 721-1. NE Selection and Pop-up Menu Window

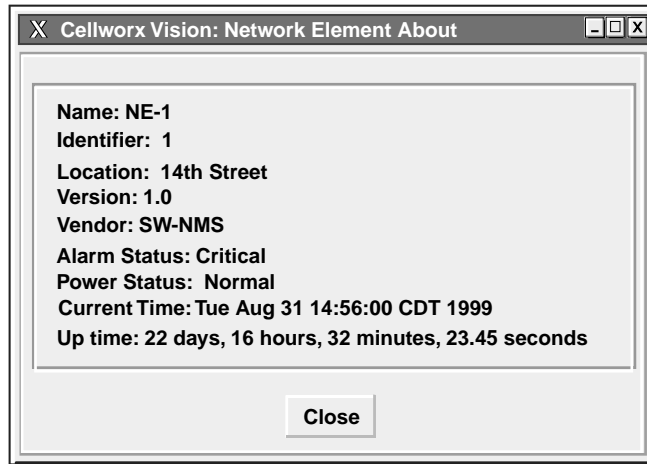

10887-D

Figure 721-2. About NE Informational Screen

## DLP-722

Page 1 of 3

## NMIC SYSTEM FILE REPLICATION

**Summary:** This procedure outlines the steps required for the user to replicate files from the active NMIC card to the standby. File replication allows an administrator to copy files that were changed. The administrator should be familiar with the Unix command structure and directories before attempting to alter system files. Some files are not automatically written to both NMICs and may need to be replicated. All configuration files accessed through the GUI are replicated on both NMICs automatically.

1. From the GUI screen, select the *Configuration* pull down menu, *NMIC Platform*, and *File Replication* using the left mouse button or by hitting *Alt+C*, *Alt+M*, and *Alt+F*. Refer to Figure 722-1.
2. The System File Replication window appears. Refer to Figure 722-2. At the Filter window, enter the directory that contains the files that need to be replicated.

► **Note:** Only files that have been modified through the Unix platform need to be replicated onto the standby NMIC.

3. The directory structure is shown in the directory window. When a directory is selected, the files contained therein are displayed in the File(s) window below. These files may be selected using the left mouse button to highlight them, and then selecting the directional tool to move them to the File(s) to be Replicated window. Multiple files may be selected from the various directories and replicated once all selections have been made. Use the following criteria when replicating files in this location:

- 1) /etc Directory – This directory contains many system configuration files requiring the discretion and careful handling to be used by a person who has unix system administration knowledge. For most of these files, it is best not to alter them.

► **Note:** NEVER replicate the file named 'hosts' in this directory.

- 2) /cellworx Directory –

- a) The following directories under /cellworx can be replicated between the active and stand-by NMICs either by direct FTP or through the file replication provided by the GUI.

► **Note:** The stand-by NMIC does periodic automatic replication of the following directories.

1. accounting
  2. alarmHistory
  3. performance
- b) Any software images under 'swImage' can be replicated (via FTP or GUI), provided that appropriate directories are created before an attempt of replication is made.

- c) The 'config' directory should be handled with discretion. All files under this directory distinguish active vs. standby NMICs except for the database files. Under steady state operating conditions, the database files on both NMICs will be identical. These files should not be modified when the NMICs are operationally "UP".

The database files under config directory are; NE.\*, and NMIC. The \* indicates the NE number or identifier. These files are normally handled by the application automatically.

4. Once all files have been selected, select the OK button at the bottom of the window. Selected files are then copied onto the standby NMIC card.
5. The informational message shown in Figure 722-3 appears stating the action being taken. Select OK.

**Stop! You have completed this procedure.**

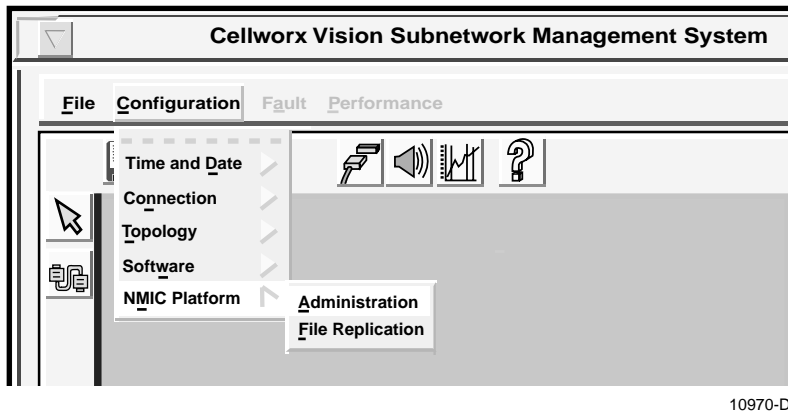
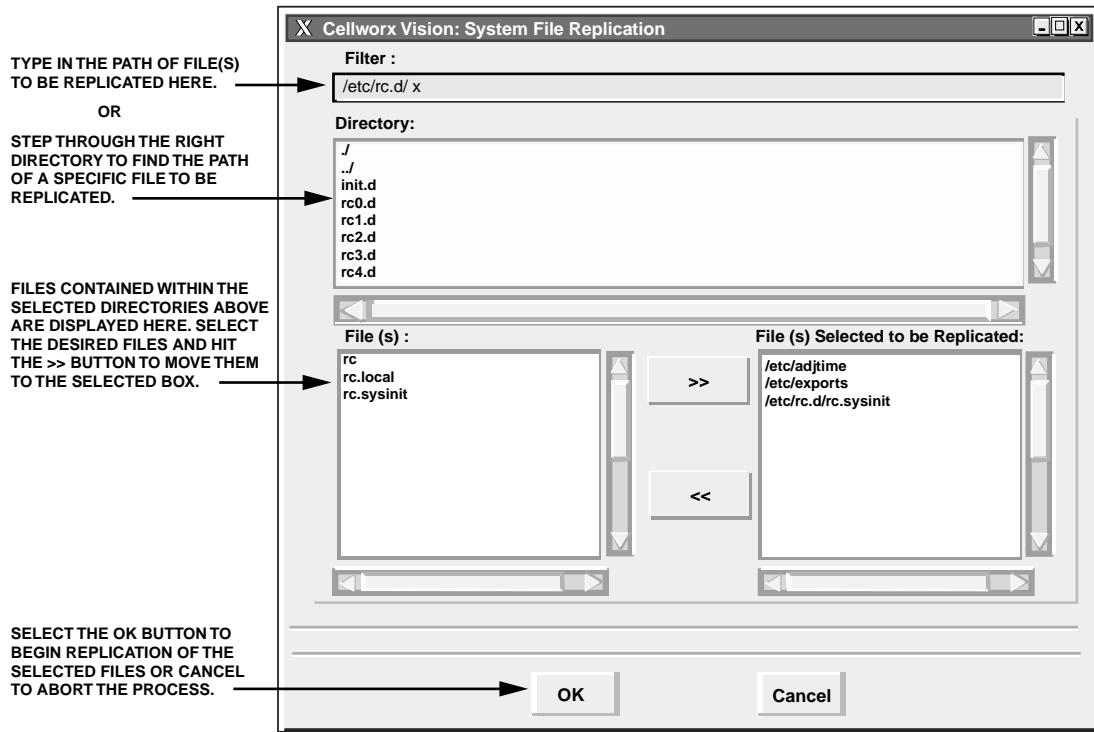

Figure 722-1. Cellworx Vision NMIC Platform Menu Tree

DLP-722  
Page 3 of 3



11721-B

Figure 722-2. Cellworx Vision system File Replication Window

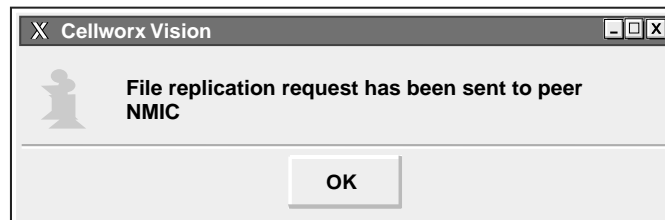

11728-A

Figure 722-3. Replication Request Confirmation



## CHANGE CONFIGURATION/TEST AN EXISTING CONNECTION

**Summary:** This procedure defines the steps required to successfully change configuration options on an existing connection or initiate an OAM cell generation/loopback or a continuity check on the connection. Changing the configuration may entail locking/unlocking the administrative state, changing the name of the connection, changing to/from a segment endpoint, or enabling/disabling NDC data collection on a connection. The user must first have accessed the system and launched the graphical user interface before attempting this procedure.

1. Access the Subnetwork Connection Filter window using one of the following methods:
  - a. Using the left mouse button, select *Configuration, Connection, and View*. Refer to Figure 723-1.
  - b. Using the direct selection keys, enter *Alt+C, Alt+N* then *Alt+V*.
  - c. Using the right mouse button, position the cursor over the NE, click and hold the button, select *View Connections*, and release the button.
  - d. Using the left mouse button, select the connection icon above the workspace.
2. The Cellworx Vision Subnetwork Connections window appears, similar to the example shown in Figure 723-2. Using the tabs, go to each page and select the Connection type, Network Element, Traffic Contract, and ATM or CES interface and then hit the *Apply* button at the bottom of the screen. The user may elect to select the connection type and the “Retrieve all selected type connections” button followed by the *Apply* button. This avoids having to select individual interfaces and nodes on the other pages.
3. The Subnetwork Connections screen appears similar to the one shown in Figure 723-3. Select a connection to be modified or tested and then single click on the *Configure* button at the bottom of the window.
3. The Subnetwork Connection Configuration window appears displaying both ends of the connection selected. Refer to Figure 723-4 for an example. The connection name is displayed at the top as well as the connection type. The connection name can be changed in this screen by typing the new name in the Connection Name box and selecting *Apply*. The upper half of the window represents one end of the connection while the bottom half represents the other end of the selected connection. The user may now lock the connection out or release a locked out connection by selecting the pad lock on the upper right corner of the window.

## CHANGING CONNECTION CONFIGURATIONS

4. To make the connection a Segment Endpoint, click anywhere on the box or text that reads *Segment Endpoint*. Adversely you may remove the endpoint designator by clicking on the same. This is true for either end of the connection.

## DLP-723

Page 2 of 5

## TESTING CONNECTIONS

5. To enable Network Data Collection (NDC) on the connection for either ingress or egress, click anywhere on the box or text next to it that reads *Ingress NDC* or *Egress NDC*.
6. To test the connection selected and displayed on the Subnetwork Connection Configuration window, click on the box next to *Test Type* which should currently read “No Test” if no test has been previously initiated on it. The selection window appears displaying the following options:
  - **No Test** – No test is in progress or requested.
  - **End-End OAM Loopback** –
  - **Segment End Loopback** –
  - **Continuity Check Source** –
  - **Continuity Check Sink** –
7. At the *Loopback Location ID* field, enter a unique ID identifying the location that the loopback cells are being generated from.
8. At the *Insert Loopback Cells* field, either leave the selection on *Towards Access Facility* which will loop the incoming cells back out to the AIC cards in the system, or click on the textbox and drag downwards to select *Towards Ring Facility* to loop the cells incoming from the RIC cards back out to the Ring.
9. The Test Status display indicates whether the connection is currently under test. Clicking on the *Test Status* button below it will refresh the status display and the *Abort Test* button will abort the test.

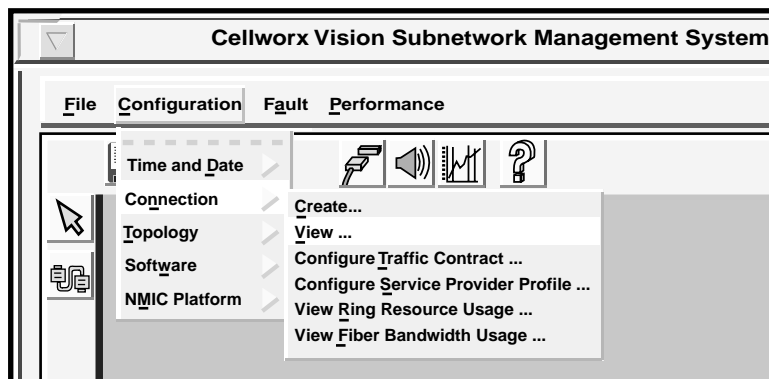

10963-D

Figure 723-1. View Connection Pull Down Menu



DLP-723  
Page 4 of 5

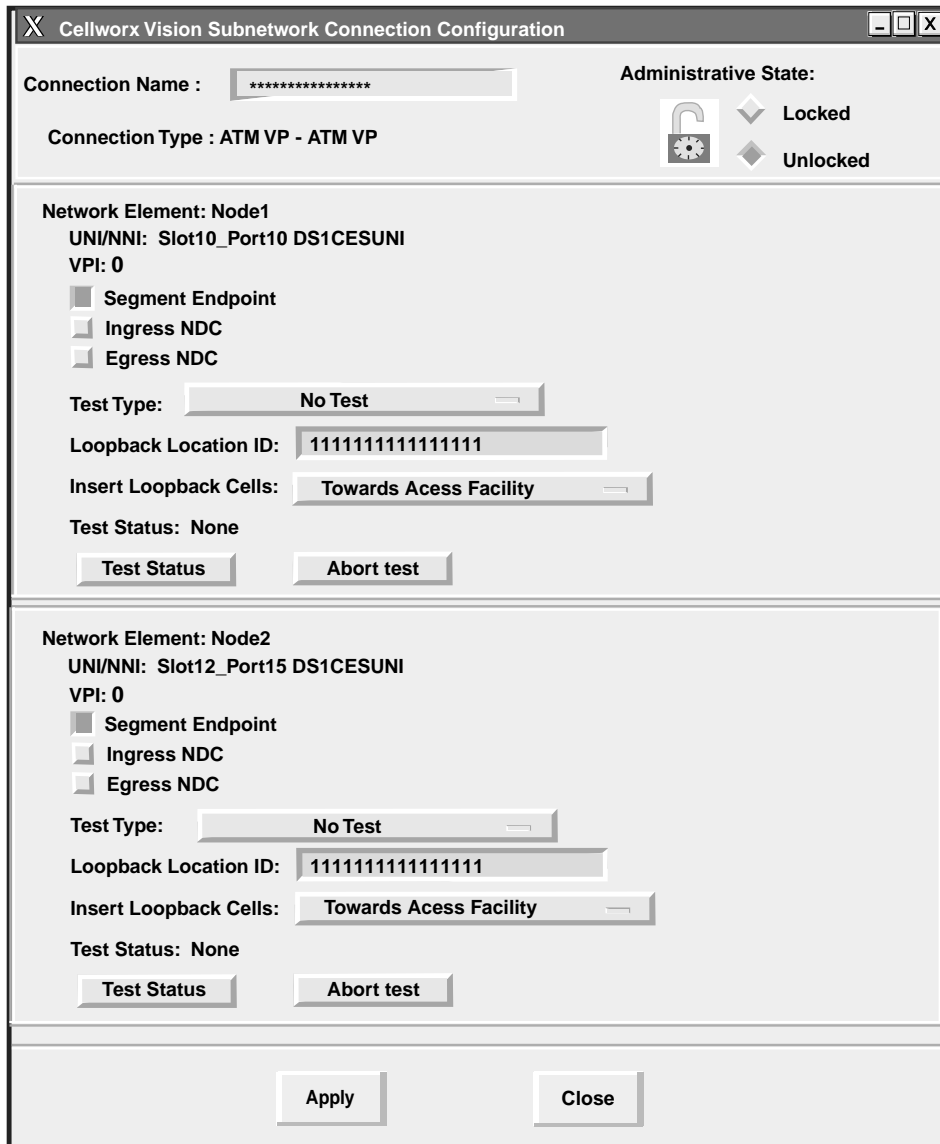

Figure 723-4. Subnetwork Connection Configuration Window

Table 723-1. Subnetwork Connection Configuration Options

SELECTION	OPTIONS	DESCRIPTION
Connection Name	User Defined	Displays the connection name selected for configuration. User may rename the connection by typing in a new name and hitting <i>Apply</i> .
Segment Endpoint	Single selection box	Sets this end of the connection as a segment endpoint for OAM cells.
Ingress / Egress NDC	On or Off	Enables or disables the network data collection for selected circuit.
Test Type	End to End OAM Segment OAM Continuity Check Source Continuity Check Sync No Test	No test is currently being administered.
Loopback Location ID		Customer assigned location identifier, used to loopback the incoming signal and transmit it back to the customer equipment, limited to 16 numeric characters.
Insert Loopback Cells	Towards Access Facility Towards Ring Facility	
Test Status	None Active	Test is not currently active. Test is currently in progress.

**DLP-724**

Page 1 of 2

**NMIC PROTECTION**

**Summary:** This procedure describes the tasks that can be performed using the NMIC Protection option under the Fault pull down menu of the Cellworx Vision GUI. The NMIC protection option allows the user to perform a manual or forced switchover from the active NMIC to the standby NMIC, or to lock the NMICs out of protection to prevent any switching activity. The active NMIC refers to the operational status of the card and can be either the working or protect card in the shelf. The protection NMIC must be located in the GNE next to the working NMIC for Phase 3.1 systems.

1. Select the **Fault** pull down menu and then **NMIC Protection** from the top of the GUI screen using the mouse or by hitting the **Alt+A** and then **Alt+P**. Refer to Figure 724-1.
2. The NMIC Protection window appears indicating which slots the working NMIC and protect NMIC are in, and their operational status. Refer to Figure 724-2. The operational status of each NMIC must be Up in order to perform any protection switching.
3. A Lockout is the highest priority in the switching hierarchy and disables the standby card, in any condition, from switching to active. The Automatic Protection Switch will be disabled when a lockout is active. If the Lockout of protection is active, it must first be released before performing a switch. To release the lockout of protection, ensure the Lockout Protection Switch option is selected and resend the request by selecting the **Apply** button. This will release the lockout.
4. To perform a manual switch, select the **Manual Switch** button at the bottom left of the window and then the **Apply** button.
5. A confirmation window appears informing the user that a switchover will result in a loss of session. Since the active card is the one that the GUI is launched from, and the user is going to change the status of the active card to standby, the user must establish a new session and launch the GUI on the newly activated card. Refer to Figure 724-3. Select **OK** to initiate the switchover or **Cancel** to abort the request.
6. The manual switch does not leave a switch condition activated so it does not need to be released. To switch back to the original active card, just select the **Manual Switch** button again followed by the **Apply** button.
7. To perform a forced switch, select the **Force Switch** button followed by the **Apply** button. Again, since the active card is the one that the GUI is launched from, and the user is going to change the status of the active card to standby, the user must establish a new session and launch the GUI on the newly activated card. Refer to Figure 724-3. Select **OK** to initiate the switchover or **Cancel** to abort the request.
8. To release the forced switch, select the **Force Switch** button followed by the **Apply** button. This will release any previous request for a forced switch and allow a manual switch to the standby card.

**Stop! You have completed this procedure.**

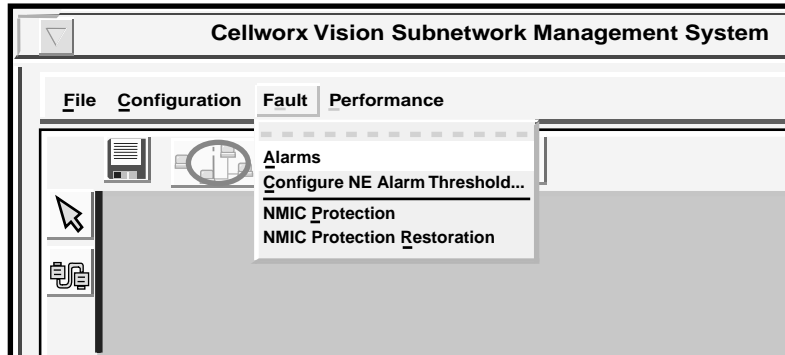

10916-D

Figure 724-1. Cellworx Vision Fault Pull Down Menu

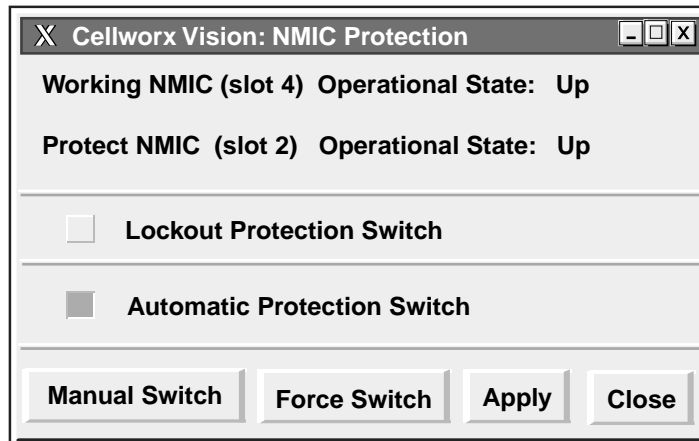

11735-A

Figure 724-2. Cellworx Vision NMIC Protection

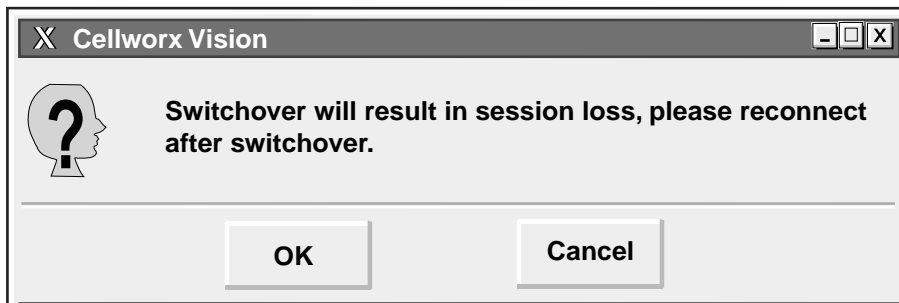

11751-A

Figure 724-3. NMIC Switchover Confirmation Window

**DLP-725**

Page 1 of 3

**NMIC PROTECTION RESTORATION**

**Summary:** This procedure describes the steps required to successfully restore NMIC protection to an operational status. The restoration process copies up to 50 files from a user selected NMIC to the other NMIC ensuring that both are synchronized with the same data. This procedure should be performed anytime the information on the NMICs are out of sync, indicated by a warning message that comes up on the GUI work space or by a flashing icon. When the NMICs are out of sync, the manual and forced protection switching functionality for the NMICs is disabled.

1. When the NMICs are out of sync, the message shown in Figure 725-1 will appear stating that the NMIC protection restoration has been lost and the user will be forced to correct the NMIC unbalance before continuing with the tasks at hand. The user must select a NMIC with the most up to date information on it to restore the database from. The active NMIC is indicated by the (ACTIVE) status next to the NMIC slot number. Select the NMIC with the most reliable information on it (*Slot2*, or *Slot4*). No configuration changes will be allowed during the restoration period.
2. The estimated time of restoration is displayed which can take up to 15 minutes depending on the size of the ring. Select the **OK** button to proceed.
3. The window changes indicating that the restoration is in progress. A percentage of completion is also provided. Refer to Figure 725-2. Once completed, the protection NMIC operational status will be Up. Refer to DLP-724.
4. If the protection restoration process fails for any reason, a flashing icon will appear in the upper left corner of the workspace. Refer to Figure 725-3. The user can invoke the restoration process at anytime after a failure when the flashing icon appears. To do so, select the **Fault** pull down menu and **NMIC Protection Restoration** using the mouse, or by hitting the **Alt+A** and **Alt+R** keys. Refer to Figure 725-4. The flashing icon will remain until the user corrects the problem.
5. If the restoration is not needed and the user initiates this process, an information window will appear stating that protection restoration is not currently needed. Refer to Figure 725-5. Select the **OK** button to continue with other tasks, otherwise follow steps 1 through 3 to complete the manually initiated restoration process.

**Stop! You have completed this procedure.**



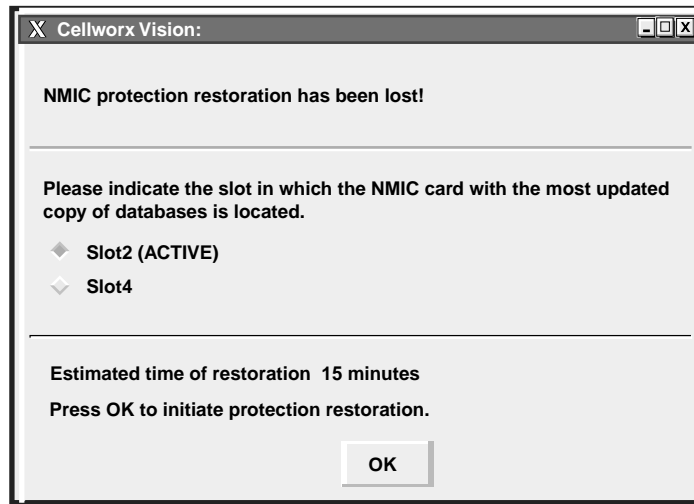
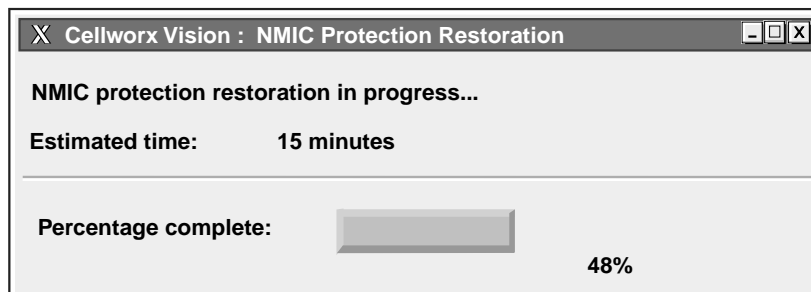
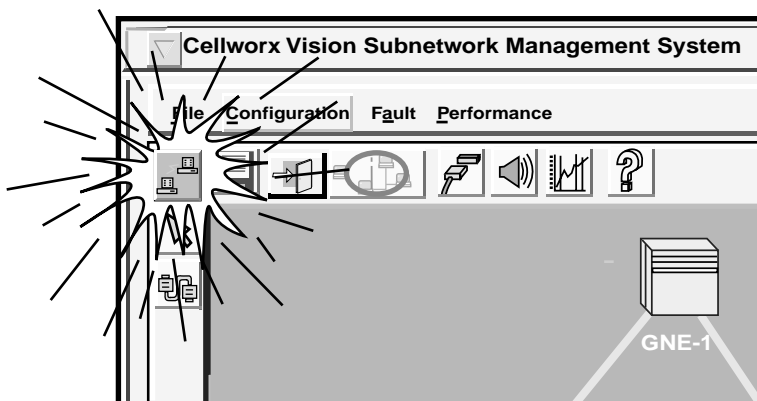

Figure 725-1. NMIC Protection Restoration Window



11734-B

Figure 725-2. NMIC Protection Restoration In Progress Window



11722-C

Figure 725-3. NMIC Protection Restoration Lost Indicator

DLP-725  
Page 3 of 3

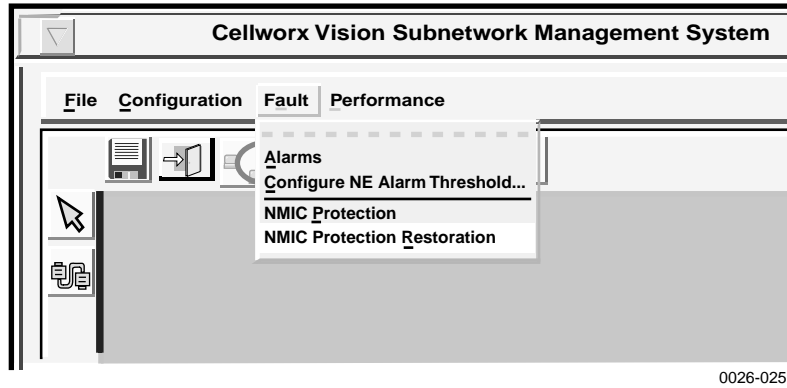

Figure 725-4. Cellworx Vision Fault Pull Down Menu

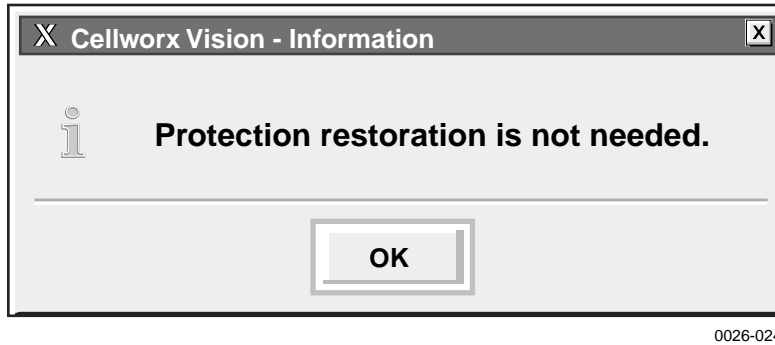

Figure 725-5. NMIC Protection Restoration Informational Message

## SET / RETRIEVE OPTICAL PORT PERFORMANCE MONITORING STATISTICS

**Summary:** This procedure describes the steps required to successfully set or retrieve the performance monitoring statistics for specified optical interface ports within a Cellworx STN network. An optical port may reside on a 2488 RIC, 622 RIC, 155 RIC, or 155 SM/MM CRS card. This procedure assumes the user has already accessed the GUI and accessed the Performance Monitoring Statistics window per NTP-008.

1. Select an NE from the list of NEs in the “Resource” section of the window. Refer to Figure 726-1. This will bring up any available card slots in the NE in the next window.
2. Select a slot/card type in the “Slot/Card Type” section of the window and all available ports will appear in the third window. Multiple slots may be selected.
3. Select the slot(s)/port(s) desired in the “Port” section of the window to display the performance monitoring layers in the “Layer” section of the window. Multiple ports may also be selected.
4. Select the layer or layers to be retrieved in the “Layer” section of the window. If a RIC or 155 CRS card was selected, SONET will be available in the PM layer window. If SONET is not available, return to step 2 of this procedure and select the proper optical interface card. ATM Transmission Convergence (TC) will also be selectable.
5. Select the time period for the report from the Interval selection window on the right. If multiple interfaces were selected, only a single time interval may be selected. If a single interface was selected, the user may specify several historical time periods to retrieve for the report. The current selection will retrieve any errors that are logged for the interface(s) specified. In no instance may the current interval and a history interval be selected at the same time.
6. Select the **Apply** button once all selections have been specified for the performance report. The Performance Monitoring Data window appears displaying any error counts for each error type. Refer to Figure 726-2 for an example.
7. If SONET Layer was selected for the report, the Section, Line, and Path errors are accessed separately using the tabs at the top of the window. Error types reported are listed in Table 726-1 for both SONET and ATM/TC. Slider bars are used to view the errors beyond the viewing area, either up or down for additional slots and ports, or to the right and left for additional error types. The user may update the current counts using the **Refresh** button at the bottom of the screen. If retrieving history counts, Refresh is disabled. The user may also reset or clear selected error types by using the **Reset Selected** or **Clear Selected** buttons at the bottom of the window.
8. Refer to TAP-100 at the end of this section for troubleshooting tips on any alarm counts.

## THRESHOLD CONFIGURATION

9. Users may specify error counts required to trip a system alarm by clicking on the **Configure Thresholds** button at the bottom of the PM Data window. This will bring up a Performance Monitoring Configuration window similar to Figure 726-3.
10. To configure the thresholds, place the cursor in the individual count boxes and type in the new threshold value. Do this for all the thresholds to be set in the Section, Line, and Path tabs. Refer to Table 726-1 for valid values. Once all counts are entered in each box, select the Apply button at the bottom of the screen to send the new data to the database. The Apply button includes each tab in the request.

**Stop! You have completed this procedure.**

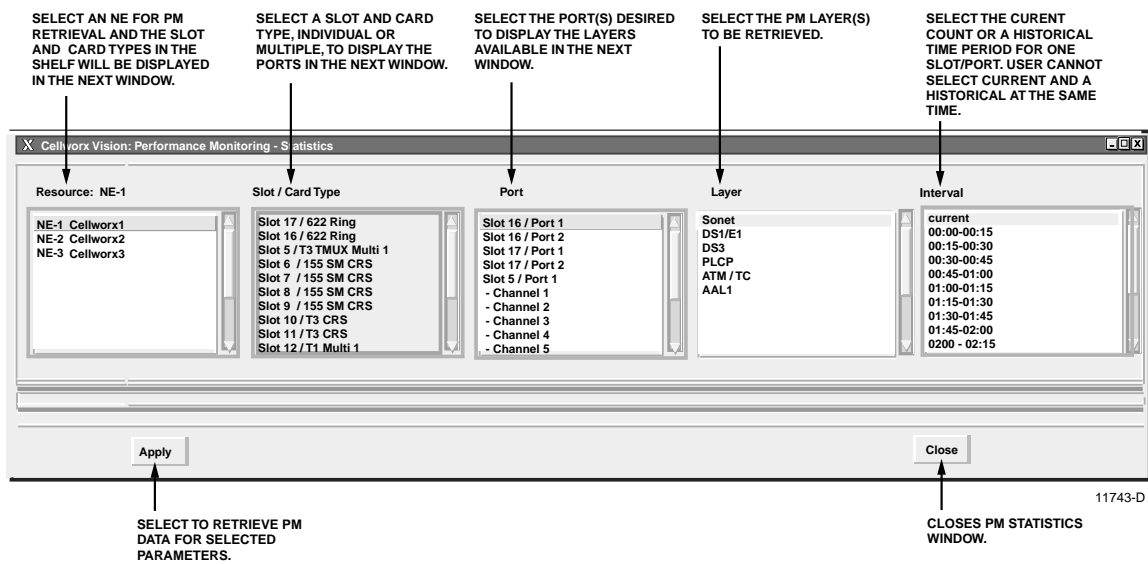
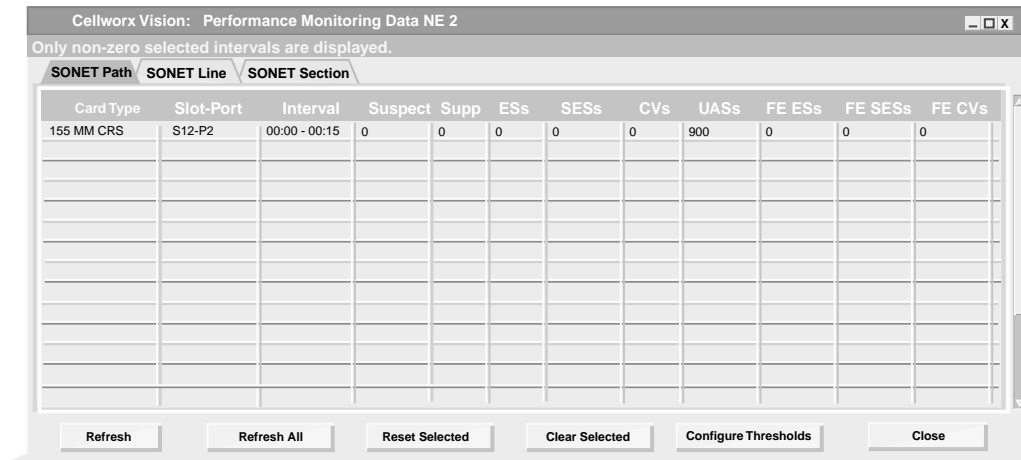
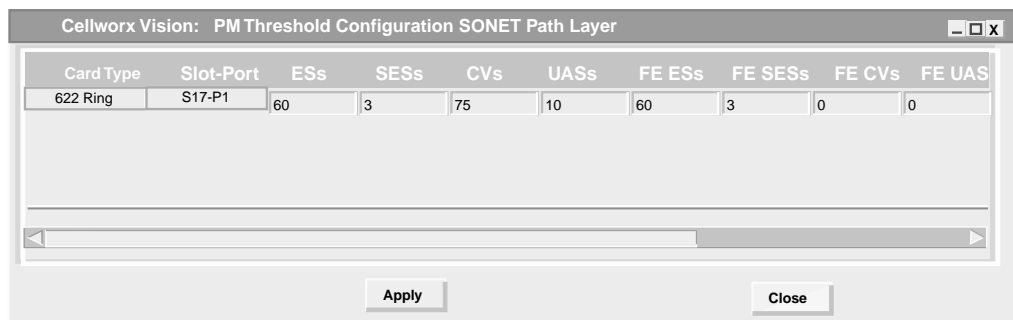

Figure 726-1. Performance Monitoring - Selection Window



13556-B

Figure 726-2. Performance Monitoring Data - SONET Port Window



13552-B

Figure 726-3. 622 Ring Card SONET Path PM Threshold Configuration Screen

Table 726-1. SONET PM Values

MONITOR TYPE	MAX 15-MIN THRESHOLD	COMMENTS
SECTION		
CV	16383	Code Violation, a count of Bit Interleaved Parity (BIP) errors detected at the Section layer using the B1 byte in the incoming SONET signal
ES	900	Errored Seconds, number of seconds in which at least one Section layer Bit Interleaved Parity (BIP), Loss Of Signal (LOS), or Severely Errored Frame (SEF) was detected
SEFS	900	Severely Errored Frame Seconds, a count of seconds that four consecutive incoming section frames are errored
SES	900	Severely Errored Seconds, a count of seconds in which a set number of Section BIP errors, LOS, or SEF were detected

(continued)

## DLP-726

Page 4 of 4

Table 726-1. SONET Layer PM Values, continued

MONITOR TYPE		COMMENTS
<b>LINE</b>		
CV-L	16383	Line Code Violation, count of BIP errors detected at the Section layer using the B2 byte in the incoming SONET signal
CV-LFE	16383	Far-end Line Code Violation, a count of BIP errors detected at the far end LTE and reported back to the near end LTE using the Remote Error Indicator (REI) in the Line overhead
ES-L	900	Line Errored Seconds, number of seconds in which at least one Line layer BIP, or an AIS condition was detected
ES-LFE	900	Far-end Line Errored Seconds, count of the seconds in which at least one Line BIP was detected by the far end LTE or an RDI-L defect was present
SES-L	900	Line Severely Errored Seconds, a count of seconds in which a set number of Line layer BIP errors, or an AIS condition were detected
SES-LFE	900	Far-end Line Severely Errored Seconds, a count of seconds in which a set number of Line layer BIP errors, or AIS were detected by the far end LTE
UAS-L	900	Line Unavailable Seconds, a count of seconds in which the Line was considered unavailable
UAS-LFE	900	Far-end Line Unavailable Seconds, a count of seconds in which the Line was considered unavailable, reported by the far end LTE to the near end LTE using the RDI in the Line overhead
<b>PATH</b>		
CV-P	16383	Code Violation, a count of BIP errors detected at the Path layer using the B3 byte of the incoming SONET signal
CV-PFE	16383	Far-end Path Code Violation, a count of BIP errors detected at the far end LTE and reported back to the near end LTE using the Remote Error Indicator (REI) in the Path overhead
ES-P	900	Path Errored Seconds, number of seconds in which at least one Path layer BIP, Alarm Indication Signal (AIS), or Loss Of Pointer (LOP) condition was detected
ES-PFE	900	Far-end Path Errored Seconds, count of the seconds in which at least one Path layer BIP was detected by the far end LTE or an RDI-P defect was present
SES-P	900	Path Severely Errored Seconds, a count of seconds in which a set number of Path BIP errors, AIS, or LOP were detected
SES-PFE	900	Far-end Path Severely Errored Seconds, a count of seconds in which a set number of Path layer BIP errors, AIS, or LOP were detected by the far end LTE and reported back to the near end LTE using the RDI-P bit in the Path overhead
UAS-P	900	Line Unavailable Seconds, a count of seconds in which the Line was considered unavailable
UAS-PFE	900	Far-end Path Unavailable Seconds, a count of seconds in which the Path was considered unavailable, reported by the far end LTE to the near end LTE using the RDI in the Path overhead

## SET / RETRIEVE T3 TMUX MULTI 1 PERFORMANCE MONITORING STATISTICS

**Summary:** This procedure describes the steps required to successfully set or retrieve the performance monitoring statistics for specified T3 TMUX MULTI 1 interface ports within a Cellworx STN network. This procedure assumes the user has already accessed the GUI and accessed the Performance Monitoring-Statistics window per NTP-008.

1. Select an NE from the list of NEs in the left selection window. Refer to Figure 727-1. This will bring up any available card slots in the NE in the next window.
2. Select a slot/card type in the second window and all available ports will appear in the third window. Multiple slots may be selected.
3. Select the slot(s)/port(s)/channels desired in the third window to display the performance monitoring layers in the fourth window. Multiple ports may also be selected.
4. Select the layer or layers to be retrieved in the fourth window. If a T3 TMUX Multi 1 slot/port and channel was selected, AAL1, ATM/TC, and DS1 will be available in the PM layer window for selection. If only the slot and port were selected the DS3 and DS1 layers will be available for selection.
5. Select the time period for the report from the Interval selection window on the right. If multiple interfaces were selected, only a single time interval may be selected. If a single interface was selected, the user may specify several historical time periods to retrieve for the report. The current selection will retrieve any errors that are logged for the interface(s) specified. In no instance may the current interval and a history interval be selected at the same time.
6. Select the **Apply** button once all selections have been specified for the performance report. The Performance Monitoring Data window appears displaying any error counts for each error type. Refer to Figure 727-2 for an example.
7. Error types reported are listed in Table 726-1 for AAL1, ATM/TC, and DS1 errors. Slider bars are used to view the errors beyond the viewing area, either up or down for additional slots and ports, or to the right and left for additional error types. The user may update the current counts using the **Refresh** button at the bottom of the screen. If retrieving history counts, Refresh is disabled.
8. Refer to TAP-100 at the end of this section for troubleshooting tips on any alarm counts.

## THRESHOLD CONFIGURATION

9. Users may specify error counts required to trip a system alarm by clicking on the **Configure Thresholds** button at the bottom of the PM Data window. This will bring up a Performance Monitoring Configuration window similar to Figure 727-3.

- To configure the thresholds, place the cursor in the individual count boxes and type in the new threshold value. Refer to Table 730-1 for valid values. Once all counts are entered in each box, select the Apply button at the bottom of the screen to send the new data to the database.

**Stop! You have completed this procedure.**

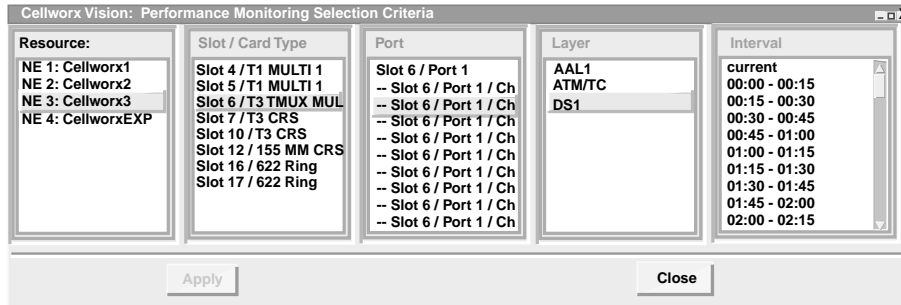

13566-B

Figure 727-1. Performance Monitoring Selection Criteria Screen (example)

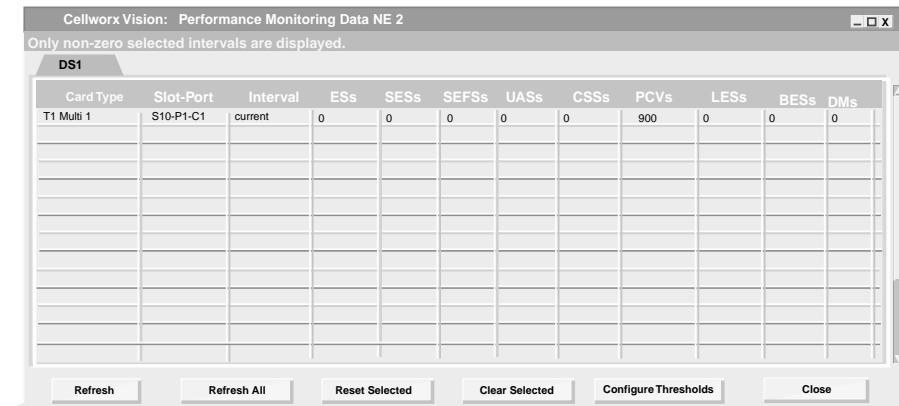

13555-C

Figure 727-2. Performance Monitoring Data - T3 TMUX Multi 1 Port (example)

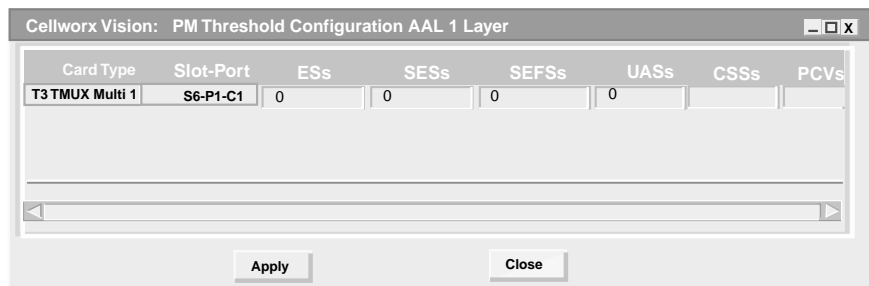

13568-B

Figure 727-3. Performance Monitoring Configuration - T3 TMUX Multi 1 Port (example)



DLP-727  
Page 3 of 4

Table 727-1. T3 TMUX Multi 1 Performance Monitoring Values

MONTYPE	MAX 15 MIN. THRESH	COMMENTS
CV-L	16383	Sets a count of Line Code Violations that the port can incur before the system declares a TCA.
ES-L	900	Sets a count of Line Errored Seconds that the port can incur before the systems declares a TCA.
CV-Pbit	16383	Sets a count of Parity bit Code Violation that the port can incur before the systems declares a TCA.
ES-Pbit	900	Sets a count of Parity bit Errored Seconds that the port can incur before the systems declares a TCA.
UAS	900	Sets a count of Unavailable Seconds that the port can incur before the systems declares a TCA.
SEFS	900	Sets a count of Severely Errored Frame Seconds that the port can incur before the systems declares a TCA.
CV-Cbit	16383	Sets a count of Cbit (Calculated parity bit of M-frame does not match received parity bits) Code Violation that the port can incur before the systems declares a TCA.
ES-Cbit	900	Sets a count of Cbit Errored Seconds that the port can incur before the systems declares a TCA.
SES-Cbit	900	Sets a count of Cbit Severely Errored Seconds that the port can incur before the systems declares a TCA.
SES-Pbit	900	Sets a count of Pbit Severely Errored Seconds that the port can incur before the systems declares a TCA.
ES	900	Sets a count of errored seconds that the port can incur before creating a TCA on the system. Error seconds determined as number of seconds $FE \geq 1$ , $SEF \geq 1$ , or any Cellworx Vision/AIS condition.
SES	900	Sets a count of line severely errored seconds that the port can incur before creating a TCA on the system. SES is determined as the number of seconds $CV-L \geq 1547$ or $LOS$ (Loss of Signal) $\geq 1$ .
UAS	900	Sets a count of unavailable seconds that the port can incur before creating a TCA on the system. UAS determined as the number of seconds that the path is unavailable.
BES	900	Sets a count of Burst Errored Seconds that the port can incur before creating a TCA on the system.
SEFS	900	Sets a count of severely errored frame seconds that the port can incur before creating a TCA on the system. SEFS determined when $SEF \geq 1$ .
DM	15	Sets a count of minutes that the port can incur a signal degradation before creating a TCA on the system.

(continued)

Table 727-1. T3 TMUX Multi 1 Performance Monitoring Values, continued

MONITOR TYPE	MAX 15 MIN. THRESH	COMMENTS
<b>AAL1 LAYER</b>		
Stuffing Cells	9900	Indicates a count of AIS cells inserted into the data stream for stuffing purposes in a 15-minute interval.
Congestion Lost Cells	7391440	Indicates a count of cells discarded in a 15-minute interval.
AAL1 Sequence Errors	3695745	A count of "Out of Sequence" transitions in a 15-minute interval.
Lost Cells	3695745	A count of cells lost in a 15-minute interval.
Buffer Overflow	900	Indicates a count of buffers that have overflowed in a 15-minute period.
Buffer Underflow	900	Indicates a count of buffers that have underflowed in a 15-minute period.
<b>ATM / TC LAYER</b>		
Suspect	1	Suspect defines counts that are suspected to have errors but may have been reset to zero by a user during the reporting period.
Supp	3695745	Suppressed intervals flag indicates that there was no data to report for an interval (all counts are zero). This saves the user from having to look at a bunch of zeros and also reduces the size of the PM data files.
Hdr Errs	3695745	Sets a count of errors in the ATM header that the system can incur before notifying the system administrator.
OAM Rcvd	3695745	A count of Operation, Administration, and Maintenance cells received in a 15-minute period. These cells are used for testing purposes such as loopback request codes.
In Cells	3695745	A total count of all of the cells that have been received on an interface. This is for user information and not configurable.
Out Cells	3695745	A total count of all of the cells that have been transmitted out from an interface. This is for user information and is not configurable.
HEC Viols	3695745	Sets a count of Header Error Checksum violations that the system can incur before declaring an alert.
OCDs	900	Sets a count of Out of Cell Delineation anomalies that the system can incur before declaring an alert.

- **Note:** Max value should be the number of cells received in a 15-minute period (or for Congestion Lost Cells, multiply this by 2). Although 31 or 32 bits are allocated, only 4106.38 cells/sec are received on a T1. In a 15-minute period (900 seconds) only 3695744.68 cell are received. Therefore the max value for all AAL1 sequence errors for a 15-minute period should be 3695745 (22 bits), and for Congestion Lost cells 7391440 (23 bits).

**DLP-728**

Page 1 of 4

**SET / RETRIEVE T3 CRS PERFORMANCE MONITORING STATISTICS**

**Summary:** This procedure describes the steps required to successfully retrieve the performance monitoring statistics for specified T3 interface ports within a Cellworx STN network. Information retrieved is on a per node and per port basis. This procedure assumes the user has already accessed the GUI and initiated the Performance Monitoring-Selection window per NTP-008.

1. Select an NE from the list of NEs in the “Resource” section of the window. Refer to Figure 728-1. This will bring up any available card slots in the NE in the next window.
2. Select a slot/card type in the “Slot/Card Type” section of the window and all available ports will appear in the third window. Multiple slots may be selected.
3. Select the port(s) desired to display the performance monitoring layers in the “Port” section of the window. Multiple ports may be selected also.
4. Select the layer or layers to be retrieved in the “Layer” section of the window. If a T3 CRS card was selected, ATM/TC (Transmission Convergence), DS3, and PLCP will be available in the PM layer window. If not, return to step 2 of this procedure and select the proper interface card.
5. Select the time period for the report from the Interval selection window on the right. If multiple interfaces were selected, only a single time interval may be selected. If a single interface was selected, the user may specify several historical time periods to retrieve for the report. The “current” selection will retrieve any errors that are actively logged for the interface(s) specified. In no instance may the current interval and a history interval be selected at the same time.
6. Select the Apply button once all selections have been specified for the performance report. The Performance Monitoring- T3 Port window appears. Refer to Figure 728-2 for an example.
7. Error types reported are listed in Table 728-1. The slider bars are used to view the errors that are beyond the viewing area, either up or down for additional slots and ports, or to the right and left for additional error types. The user may update the counts using the Refresh button at the bottom of the screen. If retrieving history counts, the Refresh button is disabled. Refer to TAP-100 at the end of this section for troubleshooting guidelines.

**THRESHOLD CONFIGURATION**

8. Users may specify error counts required to trip a system alarm by clicking on the **Configure Thresholds** button at the bottom of the PM Data window. This will bring up a Performance Monitoring Threshold Configuration window similar to Figure 728-3.

9. To configure the thresholds, place the cursor in the individual count boxes and type in the new threshold value. Refer to Table 730-1 for valid values. Once all counts are entered in each box, select the Apply button at the bottom of the screen to send the new data to the database.
10. Select the *Close* button to dismiss the open windows.

**Stop! You have completed this procedure.**

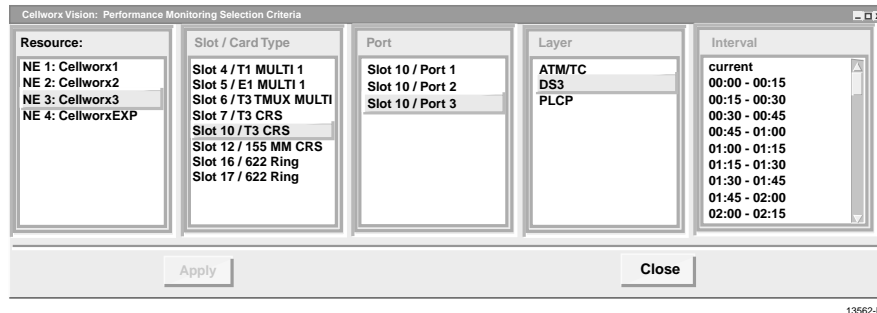

Figure 728-1. T3 CRS PM Selection Criteria Window

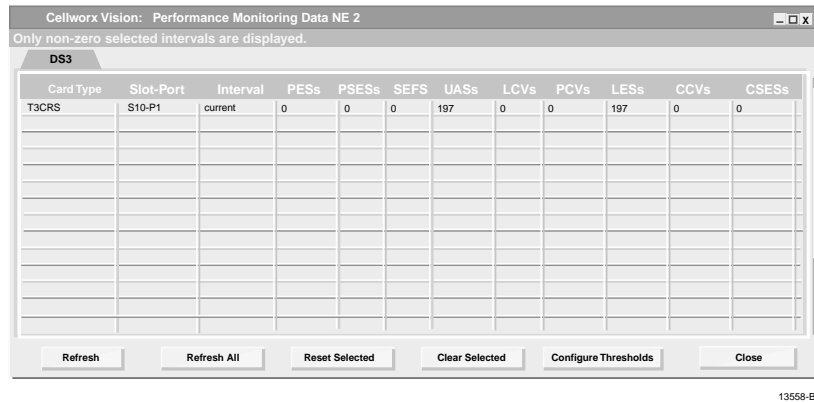

Figure 728-2. Performance Monitoring Data T3 Port Window

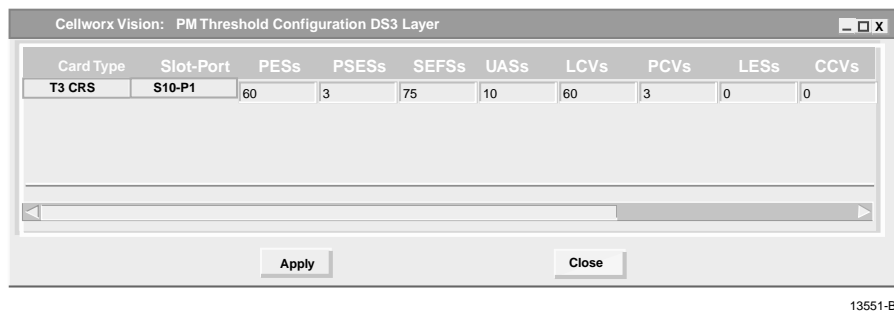

Figure 728-3. Performance Monitoring T3 Port Configuration Window

**DLP-728**  
Page 3 of 4

**Table 728-1. T3 Performance Monitoring Values**

<b>MONTYPE</b>	<b>MAX 15-MINUTE THRESHOLD</b>	<b>COMMENTS</b>
PES	900	Sets a count of Parity bit Errored Seconds that the port can incur before the system declares a TCA.
PSES	900	Sets a count of Pbit Severely Errored Seconds that the port can incur before the system declares a TCA.
SEFS	900	Sets a count of Severely Errored Frame Seconds that the port can incur before the system declares a TCA.
UAS	900	Sets a count of Unavailable Seconds that the port can incur before the system declares a TCA.
CV-L	16383	Sets a count of Line Code Violations that the port can incur before the system declares a TCA.
ES-L	900	Sets a count of Line Errored Seconds that the port can incur before the system declares a TCA.
PCV	16383	Sets a count of Path Code Violations that the port can incur before the system declares a TCA.
CCV	16383	Sets a count of Cbit Code Violation that the port can incur before the system declares a TCA.
CES	900	Sets a count of Cbit Errored Seconds that the port can incur before the system declares a TCA.
CSES	900	Sets a count of Cbit Severely Errored Seconds that the port can incur before the system declares a TCA.
<b>PLCP</b>		
SEFS	900	Sets a count of Severely Errored Frame Seconds that the port can incur before the system declares a TCA.
UAS	900	Sets a count of Unavailable Seconds that the port can incur before the system declares a TCA.
<b>ATM / TC</b>		
Suspect	1	Suspect defines counts that are suspected to have errors but may have been reset to zero by a user during the reporting period.
Supp	3695745	Suppressed intervals flag indicates that there was no data to report for an interval (all counts are zero). This saves the user from having to look at a excessive zeros and also reduces the size of the PM data files.
Hdr Errs	3695745	Sets a count of errors in the ATM header that the system can incur before declaring an alert.
OAM Rcvd	3695745	A count of Operation, Administration, and Maintenance cells received in a 15-minute period, used for testing purposes such as loopback request codes.

(continued)

Table 728-1. T3 Performance Monitoring Values

MONTYPE	MAX 15-MINUTE THRESHOLD	COMMENTS
ATM / TC, CONTINUED		
In Cells	3695745	A total count of all of the cells that have been received on an interface. This is for user information and not configurable.
Out Cells	3695745	A total count of all of the cells that have been transmitted out from an interface. This is for user information and is not configurable.
HEC Viols	3695745	Sets a count of Header Error Checksum violations that the system can incur before declaring an alert.
OCDs	900	Sets a count of Out of Cell Delineation anomalies that the system can incur before declaring an alert.

**DLP-729**

Page 1 of 4

**SET / RETRIEVE T1/E1 MULTI 1 PERFORMANCE MONITORING STATISTICS**

**Summary:** This procedure describes the steps required to successfully retrieve the performance monitoring statistics for specified T1 Multi 1 interface ports within a Cellworx STN network. Information retrieved is on a per node and per port basis. This procedure assumes the user has already accessed the GUI and initiated the Performance Monitoring-Selection window per NTP-008.

1. Select an NE from the list of NEs in the “Resource” section of the window. Refer to Figure 729-1. This will bring up any available card slots in the NE in the next window.
2. Select a slot/card type in the “Slot/Card Type” section of the window. All available ports will appear in the “Port” window. Multiple slots may be selected.
3. Select the port(s) desired to display the performance monitoring layers in the “Port” section of the window. Multiple ports may be selected also.
4. Select the layer or layers to be retrieved in the “Layer” section of the window. If a T1 Multi 1 CRS card was selected, AAL 1, ATM/TC (Transmission Convergence), and DS1 will be available in the PM layer window. If not, return to step 2 of this procedure and select the proper interface card.
5. Select the time period for the report from the Interval selection window on the right. If multiple interfaces were selected, only a single time interval may be selected. If a single interface was selected, the user may specify several historical time periods to retrieve for the report. The “current” selection will retrieve any errors that are actively logged for the interface(s) specified. In no instance may the current interval and a history interval be selected at the same time.
6. Select the Apply button once all selections have been specified for the performance report. The Performance Monitoring- T1 Multi 1 Port window appears. Refer to Figure 729-2 for an example.
7. Error types reported are listed in Table 729-1. The slider bars are used to view the errors that are beyond the viewing area, either up or down for additional slots and ports, or to the right and left for additional error types. The user may update the counts using the Refresh button at the bottom of the screen. If retrieving history counts, the Refresh button is disabled. Refer to TAP-100 at the end of this section for troubleshooting guidelines.

**THRESHOLD CONFIGURATION**

8. Users may specify error counts required to trip a system alarm by clicking on the **Configure Thresholds** button at the bottom of the PM Data window. This will bring up a Performance Monitoring Configuration window similar to Figure 729-3.





DLP-729  
Page 3 of 4

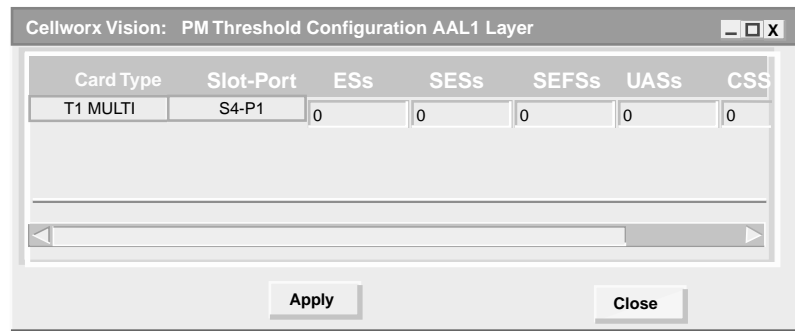

13563-B

Figure 729-3. Performance Monitoring T1 Multi Port Configuration Window

Table 729-1. T1 Multi 1 CRS Performance Monitoring Values

MONTYPE	MAX 15 MIN. THRESHOLD	COMMENTS
CV-L	16383	Sets a count of line code violations that the port can incur before creating a TCA on the system. Line code violation is a count of *BPVs and *ExZs.
ES-L	900	Sets a count of line errored seconds that the port can incur before creating a TCA on the system. ES-L is determined as number of seconds that BPV and ExZ >=1 or LOS (loss of Signal) >=1.
SES	900	Sets a count of line severely errored seconds that the port can incur before creating a TCA on the system. SES is determined as the number of seconds CV-L >=1547 or LOS (Loss of Signal) >=1.
CV-P	16383	Sets a count of path code violations that the port can incur before creating a TCA on the system. CV-P determined from SF count of FE, or ESF count of CRC errors.
UAS	900	Sets a count of unavailable seconds that the port can incur before creating a TCA on the system. UAS determined as the number of seconds that the path is unavailable.
BES	900	Sets a count of Burst Errored Seconds that the port can incur before creating a TCA on the system.
CSS	900	Sets a count of Controlled Slip Seconds that the port can incur before creating a TCA on the system. CSS is determined as a count of 1 second intervals where CS >=1.
SEFS	900	Sets a count of severely errored frame seconds that the port can incur before creating a TCA on the system. SEFS determined when SEF >=1.
DM	2	Sets a count of minutes that the port can incur a signal degradation before creating a TCA on the system.
ES	900	Sets a count of errored seconds that the port can incur before creating a TCA on the system. Error seconds determined as number of seconds FE>=1, SEF >=1, or any Cellworx Vision/AIS condition.

(continued)

Table 729-1. T1 Multi 1 CRS Performance Monitoring Values, continued

MONTYPE	MAX 15 MIN. THRESHOLD	COMMENTS
<b>AAL 1 LAYER</b>		
Stuffing Cells	9900	Indicates a count of AIS cells inserted into the data stream for stuffing purposes in a 15-minute interval.
Congestion Lost Cells	32 BITS	Indicates a count of cells discarded in a 15-minute interval.
AAL1 Sequence Errors	31 BITS	A count of "Out of Sequence" transitions in a 15-minute interval.
Lost Cells	31 BITS	A count of cells lost in a 15-minute interval.
Buffer Overflow	900	Indicates a count of buffers that have overflowed in a 15-minute period.
Buffer Underflow	900	Indicates a count of buffers that have under flowed in a 15-minute period.
<b>ATM / TC</b>		
Suspect	1	Suspect defines counts that are suspected to have errors but may have been reset to zero by a user during the reporting period.
Supp	3695745	Suppressed intervals flag indicates that there was no data to report for an interval (all counts are zero). This saves the user from having to look at a bunch of zeros and also reduces the size of the PM data files.
Hdr Errs	3695745	Sets a count of errors in the ATM header that the system can incur before notifying the system administrator.
OAM Rcvd	3695745	A count of Operation, Administration, and Maintenance cells received in a 15-minute period, used for testing purposes such as loopback request codes.
In Cells	3695745	A total count of all of the cells that have been received on an interface. This is for user information and not configurable.
Out Cells	3695745	A total count of all of the cells that have been transmitted out from an interface. This is for user information and is not configurable.
HEC Viols	3695745	Sets a count of Header Error Checksum violations that the system can incur before notifying the system administrator.
OCDs	900	Sets a count of Out of Cell Delineation anomalies that the system can incur before notifying the system administrator.

\***BPV** (Bi-Polar Violation) = Occurrence of pulses of same polarity as the previous pulse except as part of the B8ZS substitution code.

\***ExZ** (Excessive Zero) = Occurrence of any zero string greater than "N" contiguous zeros, where "N" = 7 for B8ZS or 15 for AMI (Alternate Mark Inversion).

## RETRIEVE NETWORK DATA COLLECTION (NDC) STATISTICS

**Summary:** This procedure defines the steps required to retrieve Network Data Collection (NDC) statistics from the NMIC. The NDC counts may be used to monitor individual connection traffic through the Cellworx system. The user should have accessed the NMIC and launched the GUI before attempting this procedure.

1. To access the NDC counts, from the main GUI screen access the Subnetwork Connection Filter window using one of the following methods:
  - a. Using the left mouse button, select *Configuration, Connection, and View*. Refer to Figure 730-1.
  - b. Using the direct selection keys, enter *Alt+C, Alt+N* then *Alt+V*.
  - c. Using the right mouse button, position the cursor over the NE, click and hold the button, select *View Connections*, and release the button.
  - d. Using the left mouse button, select the connection icon above the workspace.
2. The Cellworx Vision Subnetwork Connections window appears, similar to the example shown in Figure 730-2. Using the tabs, go to each page and select the Connection type, Network Element, Traffic Contract, and ATM or CES interface and then hit the *Apply* button at the bottom of the screen. The user may elect to select the connection type and the “Retrieve all selected type connections” button followed by the *Apply* button. This avoids having to select individual interfaces and nodes on the other pages.
3. The Subnetwork Connections screen appears similar to the one shown in Figure 730-3. Highlight the line with the connection that you wish to retrieve the NDC data for.
4. Select the *View* button near the top of the window to open the drop down menu. Select either the *NDC Current* or *NDC Historical* option.
5. After selecting the NDC Historical, the Select Interval window appears. Refer to Figure 730-4. Select the 15-minute interval to retrieve the NDC data for. The first option of 00:00-00:15 will retrieve the data recorded from midnight to fifteen minutes past midnight and so on for a complete 24 hour period. Hit the *Apply* button at the bottom of the screen.
6. The system retrieves the data and displays it on the Network Data Collection Statistics window. Refer to Figure 730-5 for an example. The statistics available are defined in Table 730-1.

**Stop! You have completed this procedure.**

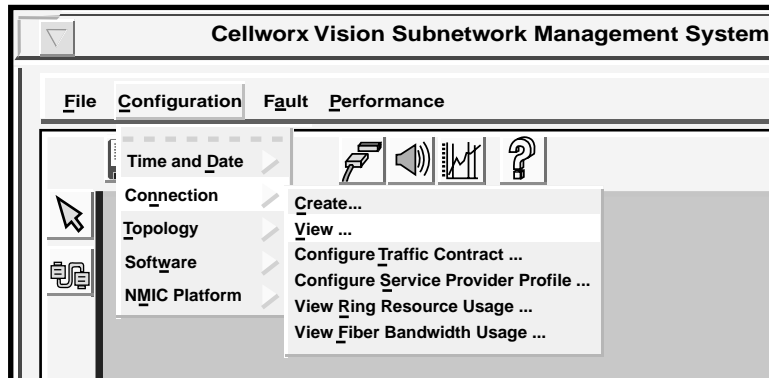

10963-D

Figure 730-1. View Connection Pull Down Menu

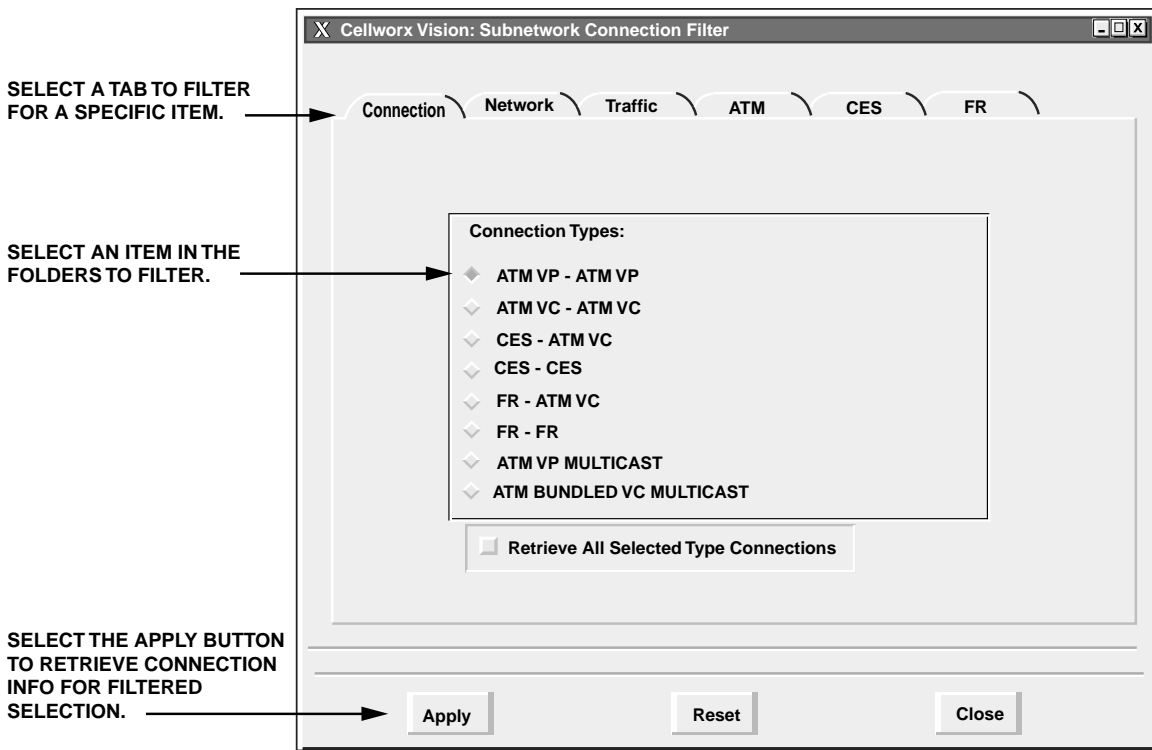

11000-F

Figure 730-2. Subnetwork Connection Filter Window

DLP-730  
Page 3 of 4

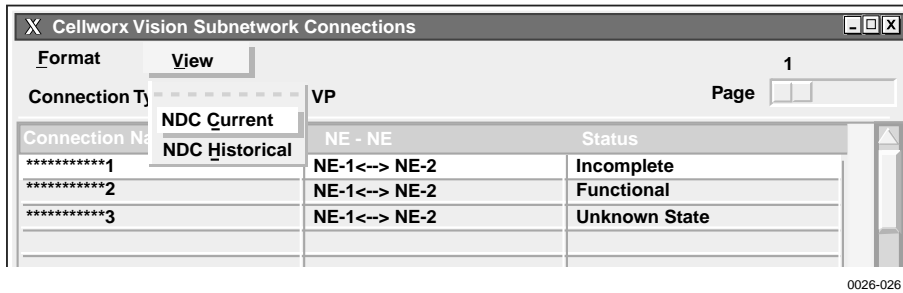

0026-026

Figure 730-3. Subnetwork Connection Display Window

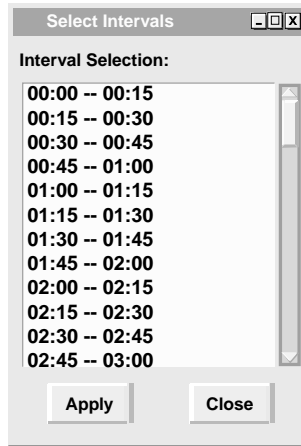

0026-028

Figure 730-4. Select Interval Window

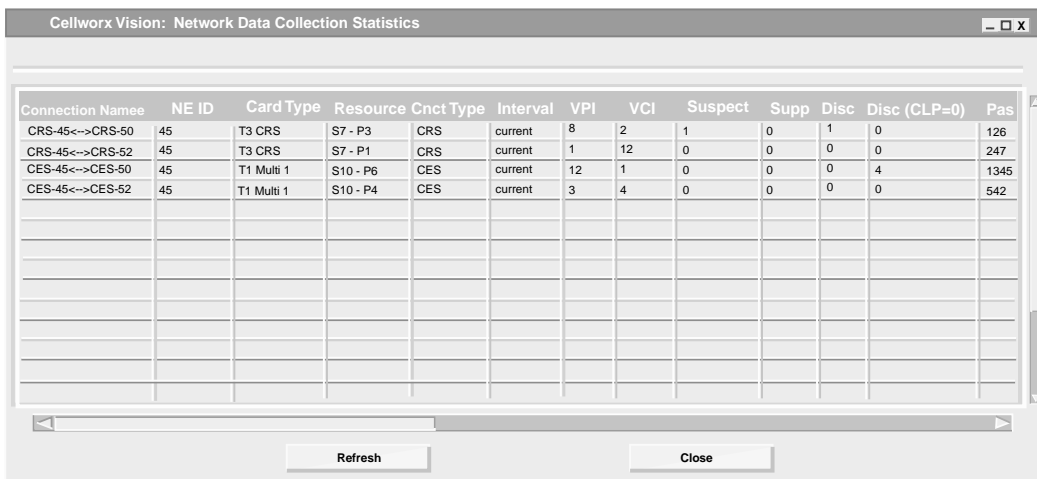

0026-027

Figure 730-5. Network Data Collection Statistics Window

**DLP-730**  
Page 4 of 4

Table 730-1. NDC Data Statistics

STATISTIC	DEFINITION
Connection Name	User assigned.
NE ID	ID number assigned to the NE where the connection originates. ID is set via a thumbwheel switch on the SC EIM at the rear of the shelf.
Card Type	Shows the type of card (i.e., T3 CRS, T1 Multi 1, etc.)
Resource	Identifies the slot and port number of the card where the connection originates.
Crcr Type	Defines the type of circuit (i.e., CES, CRS)
Interval	Shows time interval as the fifteen minute block selected by user (i.e., 01:15 – 01:30) or as current.
VPI	Shows the Virtual Path Identifier assigned to the connection by user.
VCI	Shows the Virtual Channel Identifier assigned to the connection by user.
Suspect	Shows a count of cells that are suspect of having errors or having been reset.
Supp	Shows a count of cells that have been suppressed
Disc	Shows a count of cells that have been discarded.
DISC (CLP=0)	Shows a count of cells with a Cell Loss Priority of 0 that have been discarded due to congestion on the network.
Passed	Shows a count of cells that have passed.
Ingress	Shows a count of cells that have entered the port on this connection.
Ingress (CLP=0)	Shows a count of cells with a Cell Loss Priority of 0 that have entered the port on this connection.
Egress	Shows a count of cells that have exited the port on this connection.
Egress (CLP=0)	Shows a count of cells with a Cell Loss Priority of 0 that have exited the port on this connection.

## RING UPGRADE PROCEDURE

**Summary:** This procedure will guide the user through a ring upgrade on the Cellworx STN system. It is assumed that the user has gained access to the Cellworx STN system and has launched the Graphical User Interface per NTP-016.

During this procedure, the GUI will guide the user through steps necessary to upgrade the ring one direction at a time so it will not be service affecting. The user will be allowed to fallback to the original level at any point during the upgrade process before it completes. Once the fallback is initiated, the user will not be allowed to attempt the ring upgrade again until the fallback has successfully completed. The user may fallback only to the previous ring level, and may not convert a ring at any time to a lower ring level (i.e., OC48c to OC12c).

1. The GUI main screen, select the Ring Upgrade option by single-clicking on **Configuration**, **Topology**, and then **Ring Upgrade**. The user may elect to use the shortcut key strokes of **Alt+C**, **Alt+T**, and **Alt+U**. Refer to Figure 731-1.
2. The Task Overview window appears outlining each step of the upgrade process. Refer to Figure 731-2.
3. An informational message appears instructing the user to shut down any active GUI users on the system Refer to Figure 731-3. All GUI users should be informed of the upgrade and log themselves off of the system during this process. Select the **Next>>** button.
4. The Ring Audit window appears displaying the status of the network. Fiber continuity is mandatory before this upgrade can continue. Verify the ring continuity and rectify any problems before continuing. Continuity can be determined by the Status column on the bottom right of the window. Each line should indicate an "OK" status. Refer to the example shown in Figure 731-4. Select the **Next>>** button at the bottom of the window to continue.
5. The Ring Upgrade Configuration window appears and allows the user to select the ring software. Refer to Figure 731-5. If upgrading from an OC3c ring, the user must also select the next ring configuration (OC12c or OC48c). Currently, the Cellworx STN 2.0 ring software selection will have only one selection of 2.0.0.12. Verify the selection and left click on the **Next >>** button.

**DLP-731**

Page 2 of 9

6. An informational warning message appears informing the user **NOT** to reset the RICs in slot 17 until the RICs in slot 16 have rebooted. Refer to Figure 731-6. This will allow the system to switch traffic over to the new ring on slot 16 cards when removing the slot 17 cards for upgrade. The user should refrain from any activity or intervention on the slot 17 cards or SCCs until **ALL** slot 16 cards have rebooted. This will limit any traffic loss. Select the **Next>>** button to continue.
7. A window appears displaying the RIC status in slot 16. Refer to Figure 731-7. Also another window appears instructing the user to install the new RIC cards into slot 16 of each shelf. Refer to Figure 731-8. Replace the optical cards one at a time with the new optical cards paying attention to the inbound and outbound fibers. The user may select the **OK** button either before replacing the old cards or after installing the new RIC cards.
8. The RIC status window reappears instructing the user to wait until the new RIC cards in slot 16 have booted. Refer to Figure 731-9. The user should select the **Refresh** button periodically to check the status of the booting RICs. Once the RICs have booted (show the current running software), the user may select the **Next>>** button which is grayed out until the boot process is completed.
9. Again the Ring Audit screen appears this time displaying the upgraded slot 16 with the new RICs and the slot 17 old RICs. Refer to Figure 731-10. Confirm that both rings are operating and the status columns show OK. Left click on the **Next >>** button.
10. The system responds with an informational message asking the user to confirm that the slot 16 ring system works properly. Refer to Figure 731-11. The user may select the **Suspend** button while rectifying any system problems or select the **Next >>** button to continue with the upgrade. When the user selects the **Suspend** button, a confirmation window appears as shown in Figure 731-14. Select **Halt** to stop the upgrade momentarily, **Revert** to fallback to the previous ring type (155c or 622c), or **Continue** to return to the last step completed and finish the ring upgrade. If reverting back to the previous ring type, the system software will guide the user through each step in reverse to minimize traffic loss. If continuing, select the **Next>>** button and go to the next step.
11. Another message window appears similar to Figure 731-6 this time instructing the user not to reset the cards in slot 16 until the cards in slot 17 have rebooted. Select the **Next >>** button to continue.
12. A window appears displaying the RIC statuses in slot 17. Refer to Figure 731-12 Also another window appears similar to Figure 731-8, instructing the user to install the new RIC cards into slot 17 of each shelf. Replace the optical cards one at a time with the new optical cards paying attention to the inbound and outbound fibers. The user may select the **OK** button either before replacing the old RIC cards or after installing the new RIC cards.
13. Again the Ring Audit screen appears this time displaying the upgraded slot 17 with the 2488 RICs. Refer to Figure 731-13. Confirm that both rings are operating and the status columns show OK. Left click on the **Next >>** button.



14. The system responds with an informational message similar to Figure 731-11, asking the user to confirm that the slot 17 ring system works properly. The user may select the **Suspend** button while rectifying any system problems or select the **Next >>** button to continue with the upgrade. When the user selects the **Suspend** button, a confirmation window appears as shown in Figure 731-14. Select **Halt** to stop the upgrade momentarily, **Revert** to fallback to the previous ring type (155c or 622c), or **Continue** to return to the last step completed and finish the ring upgrade. If reverting back to the previous ring type, the system software will guide the user through each step in reverse to minimize traffic loss. If continuing, select the **Next>>** button and go to the next step.
15. The final warning message comes up informing the user that upon completion of the next step, the user cannot perform a fallback procedure. Refer to Figure 731-15 and left click on the **Complete** button.
18. The system finishes its software configuration and a ring upgrade completion message appears as shown in Figure 731-16. Select the **OK** button.
19. By double clicking on any node from the GUI main screen, the chassis level view will appear and display the 2488 cards in slots 16 and 17. They should be green, indicating there is no problem. Refer to the TAP section of this document for any alarm conditions that may appear.

**Stop! You have completed this procedure.**

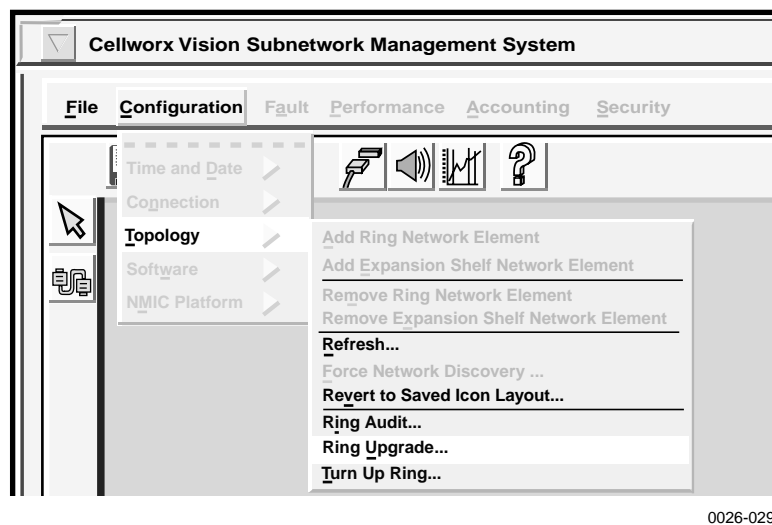
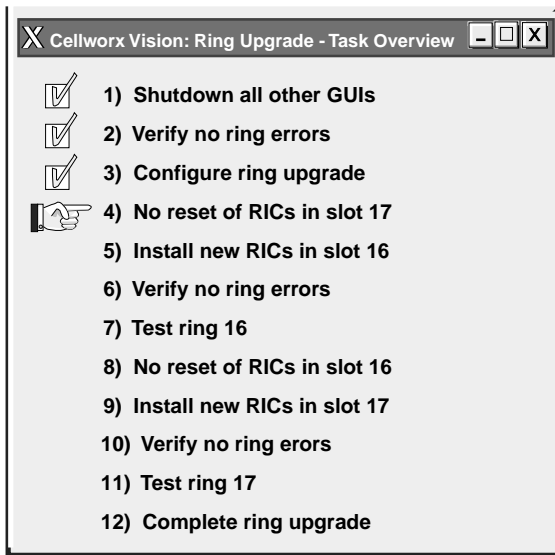

Figure 731-1. Ring Upgrade Pull-Down Menu

DLP-731

Page 4 of 9



0026-030

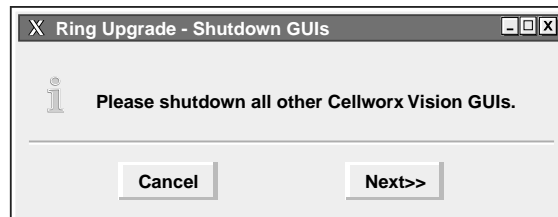

0026-031

Figure 731-2. Ring Upgrade Task Overview Window

Figure 731-3. Shutdown Active GUI Sessions

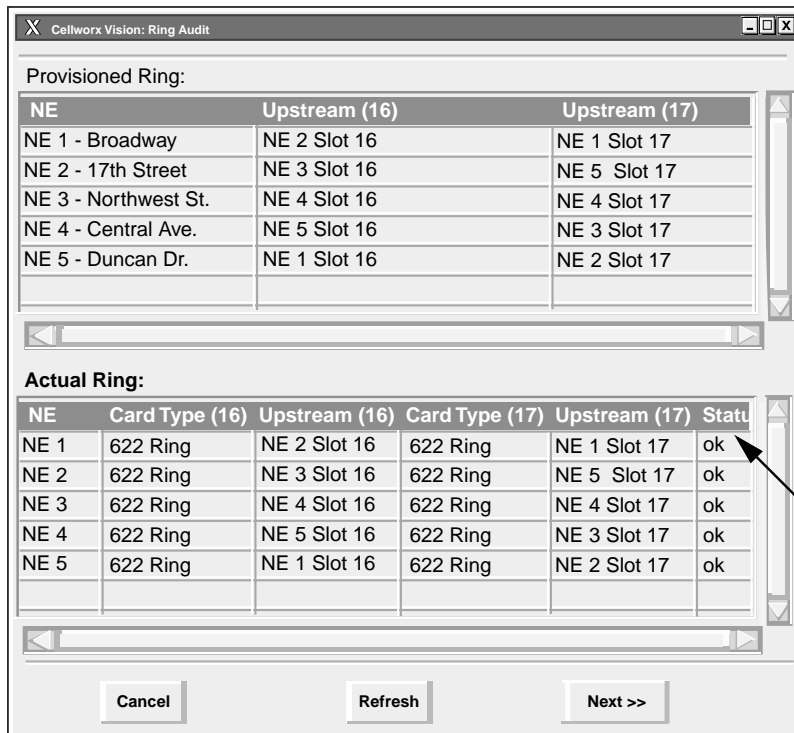

Verify Status column indicates "OK" for all links.

0026-032

Figure 731-4. Ring Audit Window (example)

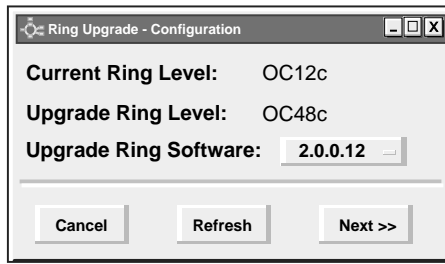

0026-033

Figure 731-5. Ring Upgrade Configuration Window

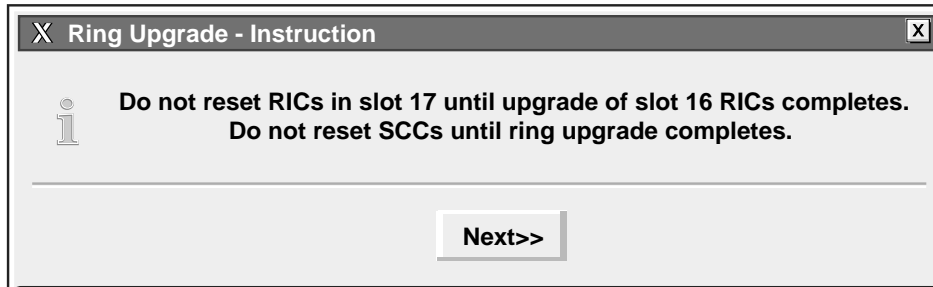

0026-034

Figure 731-6. Ring Upgrade Instructional Window

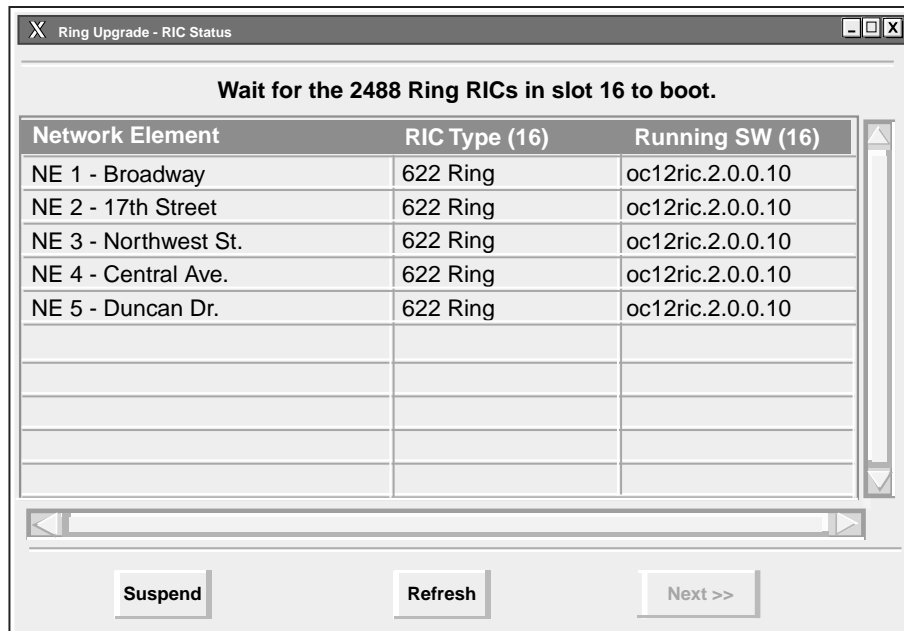

0026-035

Figure 731-7. Ring Upgrade RIC Status Window

DLP-731  
Page 6 of 9

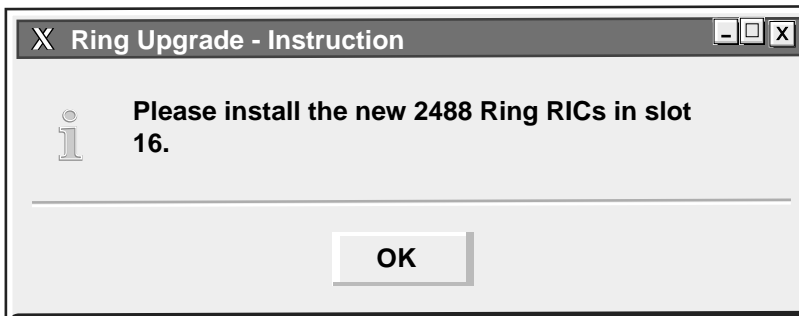

0026-036

Figure 731-8. Ring Upgrade Instructions Window - Install New RICs (example)

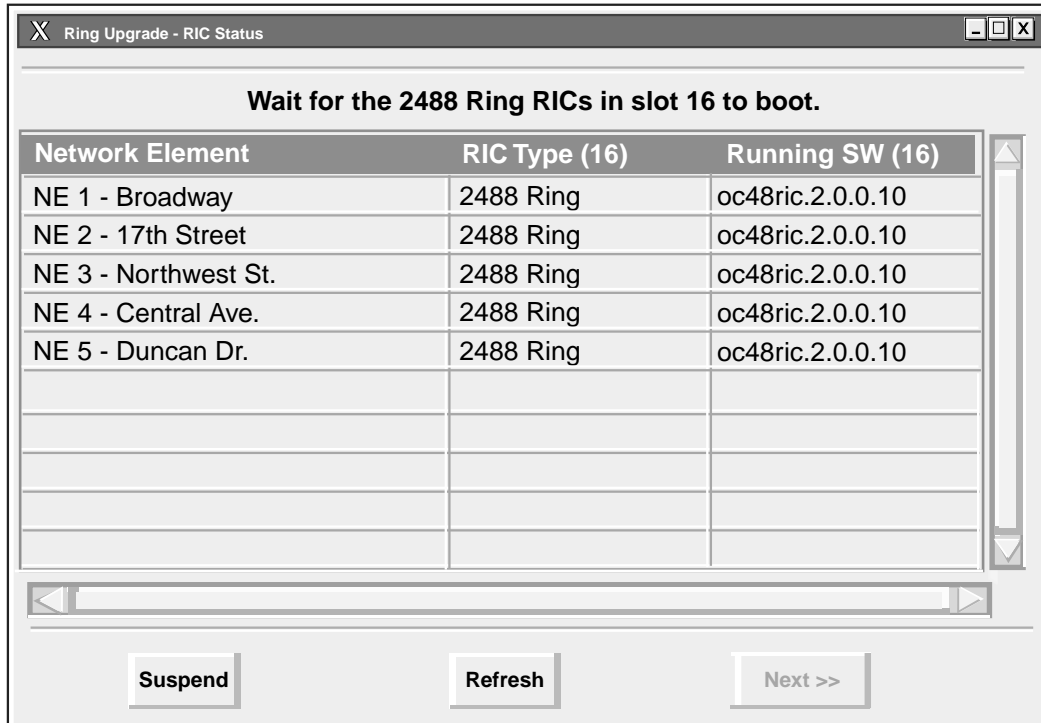

0026-037

Figure 731-9. RIC Status Window - Waiting for the 2488 RICs to Boot

**Cellworx Vision: Ring Audit**

Provisioned Ring:

NE	Upstream (16)	Upstream (17)
NE 1 - Broadway	NE 2 Slot 16	NE 1 Slot 17
NE 2 - 17th Street	NE 3 Slot 16	NE 5 Slot 17
NE 3 - Northwest St.	NE 4 Slot 16	NE 4 Slot 17
NE 4 - Central Ave.	NE 5 Slot 16	NE 3 Slot 17
NE 5 - Duncan Dr.	NE 1 Slot 16	NE 2 Slot 17

Actual Ring:

NE	Card Type (16)	Upstream (16)	Card Type (17)	Upstream (17)	Status
NE 1	2488 Ring	NE 2 Slot 16	622 Ring	NE 1 Slot 17	ok
NE 2	2488 Ring	NE 3 Slot 16	622 Ring	NE 5 Slot 17	ok
NE 3	2488 Ring	NE 4 Slot 16	622 Ring	NE 4 Slot 17	ok
NE 4	2488 Ring	NE 5 Slot 16	622 Ring	NE 3 Slot 17	ok
NE 5	2488 Ring	NE 1 Slot 16	622 Ring	NE 2 Slot 17	ok

Buttons: Cancel, Refresh, Next >>

OC48 CARDS NOW SHOWN IN SLOTS 16.      OC12 CARDS STILL PRESENT IN SLOTS 17.      STATUS SHOWS OK.

0026-038

Figure 731-10. Ring Audit Window - 2488 RIC and 622 RIC Rings

**Ring Upgrade - Instruction**

**Please verify that Ring 16 works.**

Buttons: Suspend, Next>>

0026-039

Figure 731-11. Ring Upgrade Confirmation Message

DLP-731  
Page 8 of 9

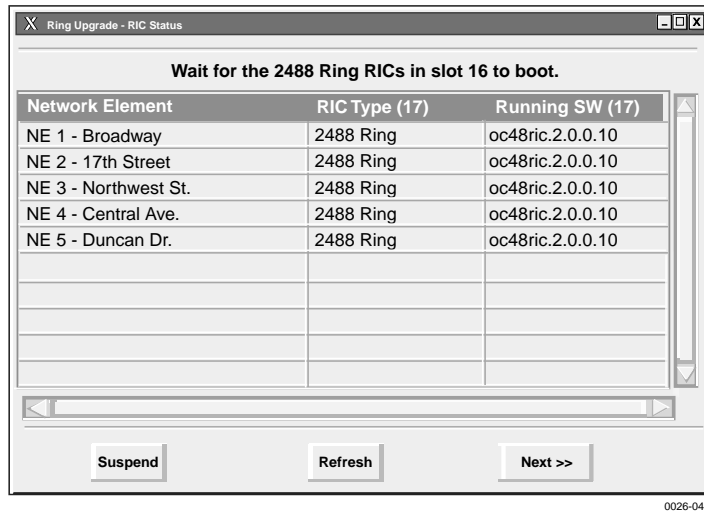

0026-040

Figure 731-12. Ring Upgrade - RIC Status Window for 2488 RICs in Slot 17

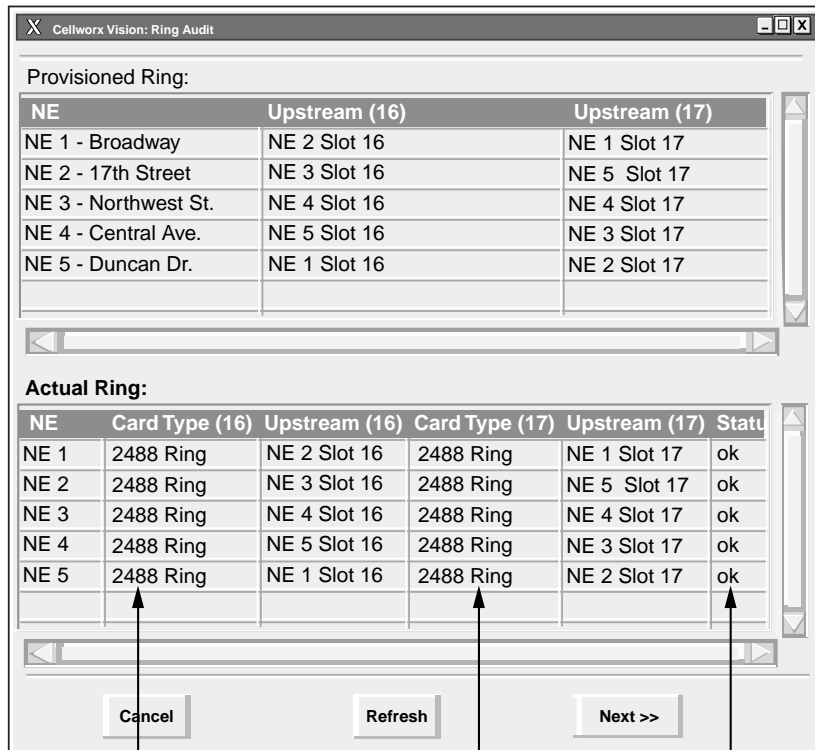

OC48 CARDS NOW SHOWN IN SLOTS 16.

OC48 CARDS NOW SHOWN IN SLOTS 17.

STATUS SHOWS OK.

0026-041

Figure 731-13. Ring Audit of 2488 Rings



0026-042

Figure 731-14. Ring Upgrade - Confirmation Message

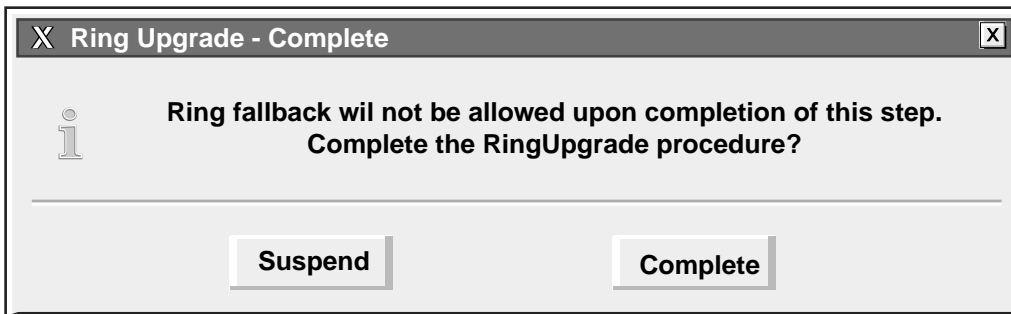

0026-043

Figure 731-15. Ring Upgrade Fallback Warning Message

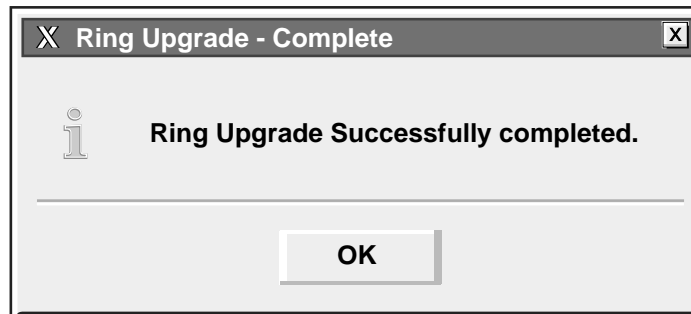

0026-044

Figure 731-16. Ring Upgrade Completion Message

**DLP-732**

Page 1 of 3

**SET / RETRIEVE FT1 FRS PERFORMANCE MONITORING STATISTICS**

**Summary:** This procedure describes the steps required to successfully retrieve the performance monitoring statistics for specified FT1 FRS interface ports within a Cellworx STN network. Information retrieved is on a per node and per port basis. This procedure assumes the user has already accessed the GUI and initiated the Performance Monitoring-Selection window per NTP-008.

1. Select a NE from the list of NEs in the “Resource” section of the window. Refer to Figure 732-1. This will bring up any available card slots in the NE in the next window.
2. Select a slot/card type in the “Slot/Card Type” section of the window. All available ports will appear in the “Port” window. Multiple slots may be selected.
3. Select the port(s) desired to display the performance monitoring layers in the “Port” section of the window. Multiple ports may be selected.
4. Select the layer to retrieve in the “Layer” section of the window. If a FT1 or FE1 FRS card was selected, DS1 will be available in the PM layer window. If not, return to step 2 of this procedure and select the proper interface card.
5. Select the time period for the report from the Interval selection window on the right. If multiple interfaces were selected, only a single time interval may be selected. If a single interface was selected, the user may specify several historical time periods to retrieve for the report. The “current” selection will retrieve any errors that are actively logged for the interface(s) specified. In no instance may the current interval and a history interval be selected at the same time.
6. Select the Apply button once all selections have been specified for the performance report. The Performance Monitoring window appears. Refer to Figure 732-2 for an example.
7. Error types reported are listed in Table 732-1. The slider bars are used to view the errors that are beyond the viewing area, either up or down for additional slots and ports, or to the right and left for additional error types. The user may update the counts using the Refresh button at the bottom of the screen. If retrieving history counts, the Refresh button is disabled. Refer to TAP-100 at the end of this section for troubleshooting guidelines.

**THRESHOLD CONFIGURATION**

8. Users may specify error counts required to trip a system alarm by clicking on the **Configure Thresholds** button at the bottom of the PM Data window. This will bring up a Performance Monitoring Configuration window similar to Figure 732-3.





DLP-732  
Page 3 of 3

Card Type	Resource	ESs	SESs	SEFSs	UASs	CSSs	PCVs	LESs	BESs
FT1 FRS	10-1	60	3	75	10	60	3		
FT1 FRS	10-2	60	3	75	10	60	3		

Apply Close

0026-058

Figure 732-3. Threshold Configuration Screen

## SET / RETRIEVE FE1 FRS PERFORMANCE MONITORING STATISTICS

**Summary:** This procedure describes the steps required to successfully retrieve the performance monitoring statistics for specified FE1 FRS interface ports within a Cellworx STN network. Information retrieved is on a per node and per port basis. This procedure assumes the user has already accessed the GUI and initiated the Performance Monitoring-Selection window per NTP-008.

1. Select an NE from the list of NEs in the “Resource” section of the window. Refer to Figure 733-1. This will bring up any available card slots in the NE in the next window.
2. Select a slot/card type in the “Slot/Card Type” section of the window. All available ports will appear in the “Port” window. Multiple slots may be selected.
3. Select the port(s) desired to display the performance monitoring layers in the “Port” section of the window. Multiple ports may be selected also.
4. Select the layer to be retrieved in the “Layer” section of the window. If a FE1 FRS card was selected, DS1 will be available in the PM layer window. If not, return to step 2 of this procedure and select the proper interface card.
5. Select the time period for the report from the Interval selection window on the right. If multiple interfaces were selected, only a single time interval may be selected. If a single interface was selected, the user may specify several historical time periods to retrieve for the report. The “current” selection will retrieve any errors that are actively logged for the interface(s) specified. In no instance may the current interval and a history interval be selected at the same time.
6. Select the Apply button once all selections have been specified for the performance report. The Performance Monitoring- FE1 FRS Port window appears. Refer to Figure 733-2 for an example.
7. Error types reported are listed in Table 733-1. The slider bars are used to view the errors that are beyond the viewing area, either up or down for additional slots and ports, or to the right and left for additional error types. The user may update the counts using the Refresh button at the bottom of the screen. If retrieving history counts, the Refresh button is disabled. Refer to TAP-100 at the end of this section for troubleshooting guidelines.

## THRESHOLD CONFIGURATION

8. Users may specify error counts required to trip a system alarm by clicking on the **Configure Thresholds** button at the bottom of the PM Data window. This will bring up a Performance Monitoring Configuration window similar to Figure 733-3.



Cellworx Vision: PM Threshold Configuration DS1 Layer

Card Type	Resource	ESs	SEs	SEFSs	UASs	CSSs	PCVs	LESs	BESs
FE1 FRS	10-1	60	3	75	10	60	3		
FE1 FRS	10-2	60	3	75	10	60	3		

Apply Close

0026-059

Figure 733-3. Threshold Configuration Screen

## HELP

**Summary:** This procedure details the information displayed when the user selects the Help pull down menu and chooses either the Contact or About option.

1. From the Cellworx Vision GUI main menu, select **Help** from the list of pull down menus positioning the pointer on it and clicking the left mouse button once.

### Contact

2. Select the **Contact** option from the list under Help.
3. The Contact window appears displaying the contact numbers for General Information, Sales Information and Literature, and Technical Support. Refer to Figure 735-1. Also provided is ADC Telecommunications Internet address.

### About

4. Select the **About** option from the list under Help.
5. The About Cellworx window appears displaying the current software version and copyright information for the Cellworx Vision GUI software. Refer to Figure 735-2.

**Stop! You have completed this procedure.**

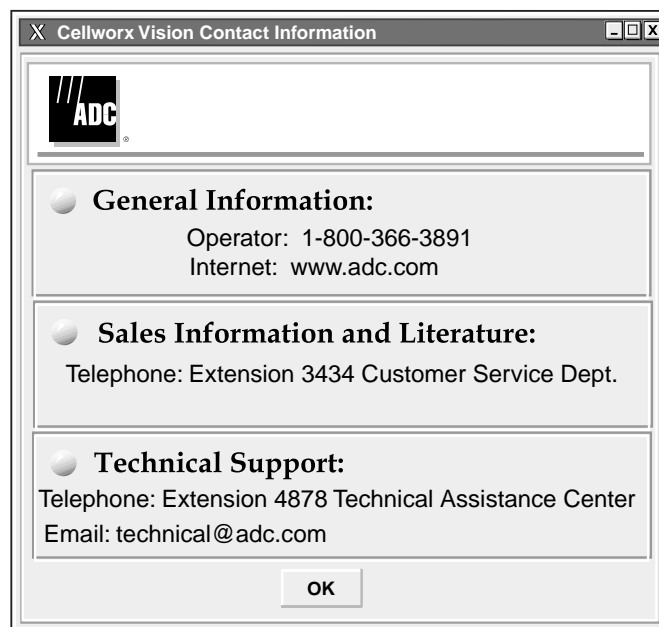

10909-E

Figure 735-1. Cellworx Vision Contact Window

DLP-735  
Page 2 of 2

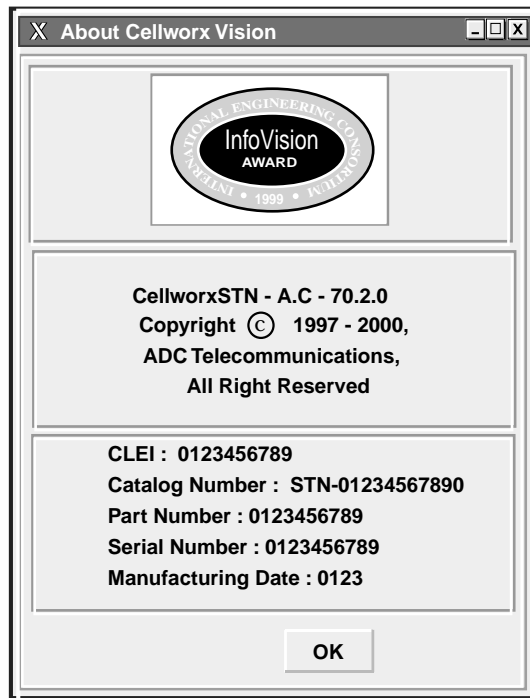

Figure 735-2. Cellworx Vision About Window

## REVERT TO SAVED ICON LAYOUT

**Summary:** This procedure describes the steps required to successfully redraw the layout of the NE icons on the GUI work area, returning them to their last saved position. This functionality enables the user to group NEs that may be collocated, separate them according to their geographical locations, or isolate nodes from the groups for easier identification and access, etc. When a system discovery is completed on all NEs, or when the icon coordinates do not match the database, a warning message appears recommending that the user re-save the icon layout. See Figure 736-1. At this point the user should organize the display and save the new layout. Otherwise, the user may redraw the ring at any time.

1. To change the layout of the Icons, select the arrow tool on the toolbar on the left side of the screen. Refer to Figure 736-2.
2. Click on and drag the NEs to the desired positions on the screen, and release the mouse button. When an icon is selected using a single click with the arrow tool, it becomes encircled with a white ring even when not being moved. Refer to Figure 736-2. The Icons stay positioned in the new locations and maintain the connections between them.

◆ **Note:** The user may not change physical interconnections between the NEs simply by moving the icons around on the GUI screen.

3. To return the GUI screen to the last saved layout, select the *Configuration* pull down menu, *Topology* and *Revert to Saved Icon Layout* (*Alt+C*, *Alt+T*, and *Alt+V*.) Refer to Figure 736-3.
4. To save the current icon layout, select *File* and *Save Icon Layout* (*Alt+F*, *Alt+S*.) See Figure 736-4. The user may also save the layout using the disk icon on the tool bar just above the work area.
5. A confirmation window appears as shown in Figure 736-5. Select *OK*. The newly drawn Icon layout will remain this way each time the GUI is launched, until the layout is redrawn and saved again.

◆ **Note:** A message will prompt the user to save the new icon layout if at least one of the icons has been moved and the user attempts to log off of the GUI by selecting the *File* pull down menu, and *Exit* (*Alt+F* and *Alt+X*). Refer to Figure 736-6.

◆ **Note:** If the GUI is closed without saving the new icon layout, the screen will default to the previous layout upon re-initialization of the GUI.

**Stop! You have completed this procedure.**



DLP-736  
Page 2 of 4

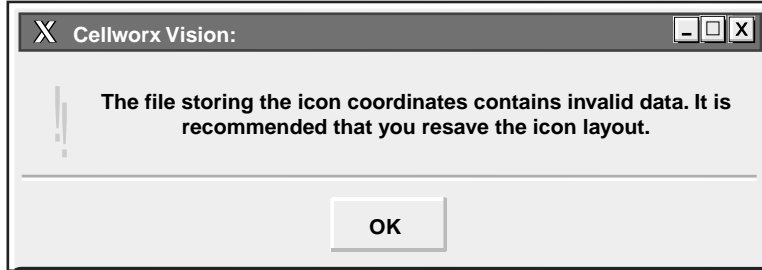

10929-B

Figure 736-1. Cellworx Vision Save Icon Coordinates Warning Message

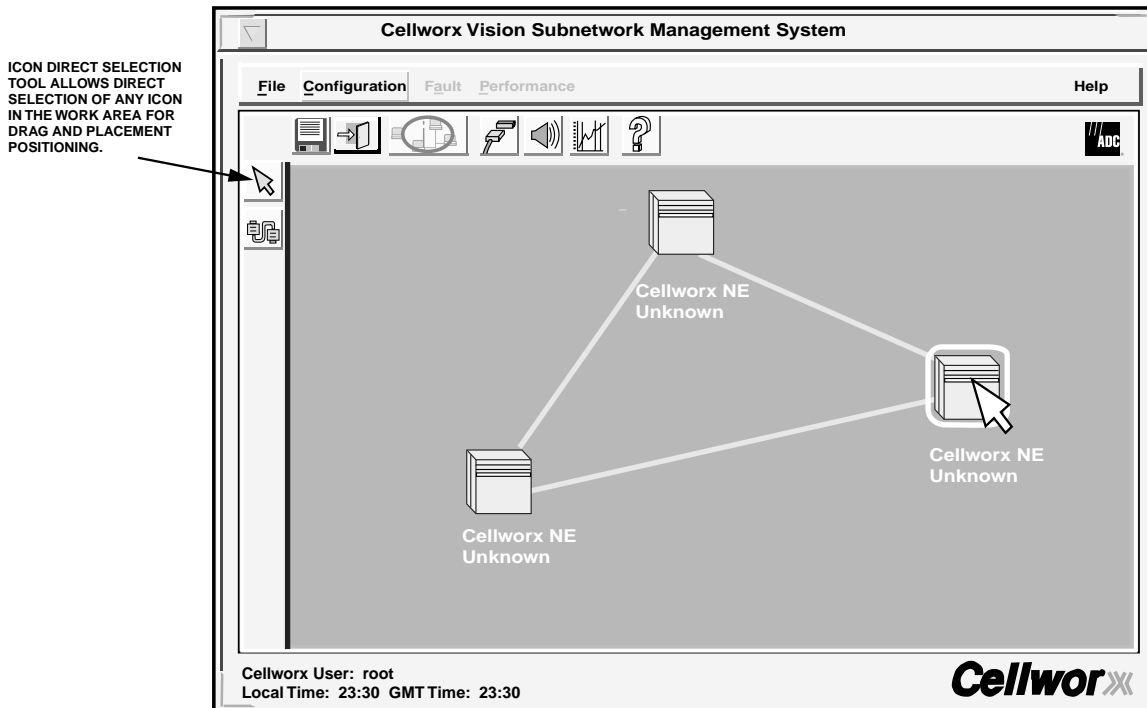

11720-D

Figure 736-2. Redraw Icon Layout Screen

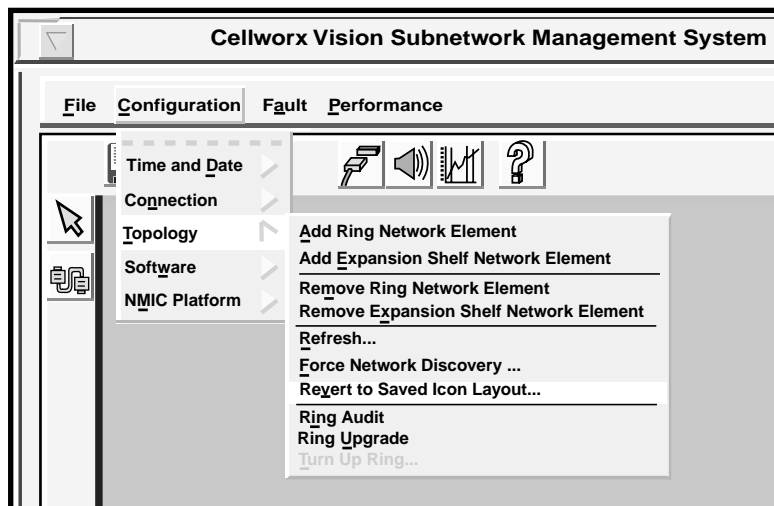

10972-E

Figure 736-3. Cellworx Vision Direct Selection Icon and Revert to Saved Icon Layout Pull Down Menu Structure

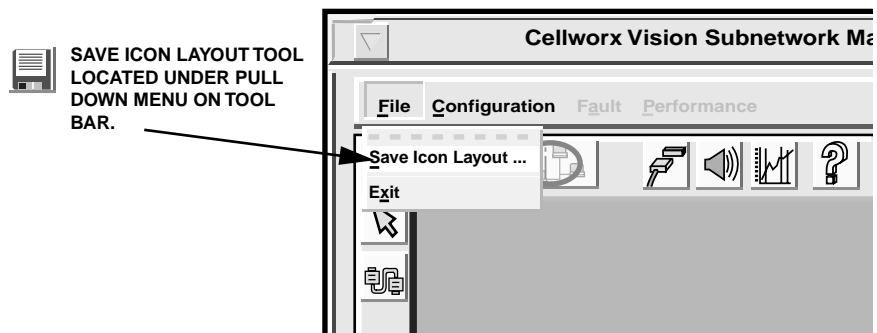

SAVE ICON LAYOUT TOOL LOCATED UNDER PULL DOWN MENU ON TOOL BAR.

11755-B

Figure 736-4. Save NE Icon Layout Pull Down Menu or Diskette Icon Tool

DLP-736  
Page 4 of 4

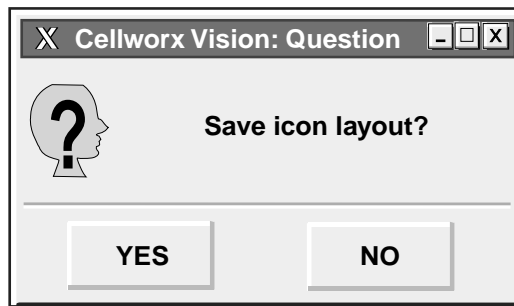

10986-B

Figure 736-5. Cellworx Vision Save Icon Layout Verification Window

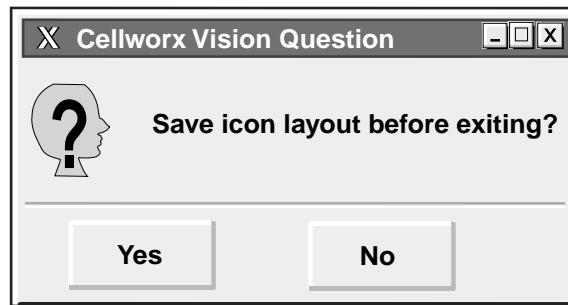

10985-C

Figure 736-6. Cellworx Vision Save Icon Layout Verification Window

## ADD A RING NETWORK ELEMENT

**Summary:** This procedure describes the steps required to add a new Cellworx STN ring node to an existing in service ring network. During this procedure the technician will be required to disconnect fibers in the existing system and reconnect them to the new node. The Graphical User Interface (GUI) will step the technician through this process without causing traffic loss in the network. The instructions provided by the GUI should be followed precisely to minimize service impact on the upgrade. If adding a second node to a stand-alone terminal, refer to NTP-004 for the proper procedure.

1. From the GUI screen, use the left mouse button to select the **Configuration** pull down menu located above the workspace, and then **Topology** and **Add Ring Network Element**. This can also be accomplished by entering **Alt+C**, **Alt+T**, and **Alt+A**. Refer to Figure 737-1.
2. The Cellworx Vision: Add Ring NE - Task Overview window appears as shown in Figure 737-2. The tasks to be performed are listed in order from 1 to 17 with a pointer indicating the current task. If the network currently has only two NEs, continue to step 3. If the network already has three or more NEs, the first task is to select the two NEs in which the new one will be positioned between. Refer to Figure 737-3. After making the selection select the **Next** button at the bottom of the window.
3. Task number 2 instructs the user to enter the NE identifier of the new node, and the window shown in Figure 737-4 appears. Using the left mouse button, click and hold on the slide bar button and move it to the right until the desired ID appears above the bar. In this example shown, the 2 is selected.
4. If an ID is entered that already exists, the message window shown in Figure 737-5 will appear. Select OK and choose another ID number. Be sure the number selected is the same as the number set on the node during installation via the rotary switches on the protect SC EIM card.
5. After making the ID selection, choose the **Next** button. The pointer on the Task Overview window moves to step 3, instructing the user to disconnect the transmit fiber from the left RIC (card in slot 16) on a specified NE. Refer to Figure 737-6 for an example. Follow the instructions provided in the window for the NE specified and hit **Next**.
6. A similar window appears instructing the user to disconnect the receive fiber on the left RIC (slot 16) in the other specified NE. Follow the instructions provided in the window for the NE specified and hit **Next**.
7. Step 5 of the Task Overview instructs the user to connect the new NE to the left RICs. Refer to the window shown in Figure 737-7. This connection will establish the ring connection in one direction utilizing the new NE. Connect left RICs per instructions for the NE specified and select **Next**.

8. The system now attempts to boot the new NE, as indicated in step 6 of the Task Overview and the window shown in Figure 737-8. The new node should boot momentarily (dependent on the connection speed over FTP, may take a minute or more.) If the boot-up process exceeds five minutes, the user is shown another window, which prompts the user to retry or abort. Refer to Figure 737-9. Follow the instructions and select either **Quit** or **Retry**. If Quit is selected, the Add NE - Reconnect Cables window appears. Refer to Figure 737-10. Follow the instruction to return the equipment to its original physical state and select **Quit**, otherwise select **Retry**.
9. Next the Cellworx Vision software configuration window appears for the new NE and the Task Overview pointer moves to step 8. Refer to Figure 737-11. At this point the SC card(s) should show a running software image but the RICs will be blank. Follow the instructions at the top of the window to select a software image for the RICs and then hit **Apply**.
10. The Download Status column changes to Loading for both of the RIC cards. This process will take up to four minutes. During this process the user may select the **Refresh** button periodically to update the display.
  - ◆ **Note:** If the screen is refreshed during the RIC software download, the Download Status column will change to None. This is OK. The RICs will continue to boot. Once completed with the boot process, the user must select **Refresh** again to update the Running Software Version column.
11. Upon completion of the software download to both RICs, and the user selecting **Refresh**, both RICs will have a running software version displayed and the **Skip** button at the bottom of the screen is changed to a **Continue** button.
12. Select the **Continue** button. The system now attempts to verify connectivity, backs up the NMIC database, and discovers the new NE, indicated by the pointer on step 9 to 11 of the Task Overview window, and the discovering network message window appears as shown in Figure 737-12. If a problem is encountered during discovery, the message window shown in Figure 737-13 will appear instructing the user to check fiber connections. The user may then retry the discovery or abort the entire process. A discovery verifies the physical connectivity between the nodes and should take less than ten seconds.
13. The next two windows (steps 12 and 13 of the Task Overview) direct the user to disconnect the other set of fibers between the RICs in the right slots (slot 17) of NE1 and NE2, similar to the window shown in Figure 737-6. Follow the instructions and select **Next** once completed.
14. Step 14 of the Task Overview instructs the user to connect the new NE (3 in this example) to the right RICs (slots 17 of each node), similar to the window shown in Figure 737-7. This connection will complete the ring connection for the outer direction through the new NE. Connect the right RICs per the instructions for the NE specified and select **Next**.

**DLP-737**

Page 3 of 8

15. The system now attempts to verify the new NE is connected correctly over both ring directions, indicated by the pointer on step 15 of the Task Overview window. The “Discovering Network” message window appears as shown in Figure 737-12. Discovery verifies the physical connectivity between the nodes and should take less than ten seconds.
16. The system now restores all traffic across both ring directions through the new NE. Subsequently, the “Add NE” task is complete and the topology is updated as per step 17 of the Task Overview window. The system responds with a message window indicating that it is updating the network topology and to please wait. Refer to Figure 737-14.
18. The user will be prompted to save the new icon layout. Refer to Figure 737-15. To do this, select the disk icon on the tool bar above the work area or select the **File** pull down menu and **Save Icon Layout** or by entering **Alt+F** followed by an **Alt+S** on the keyboard. Refer to Figure 737-16.
19. The user may now provision the new node per NTP-006.

**Stop! You have completed this procedure.**

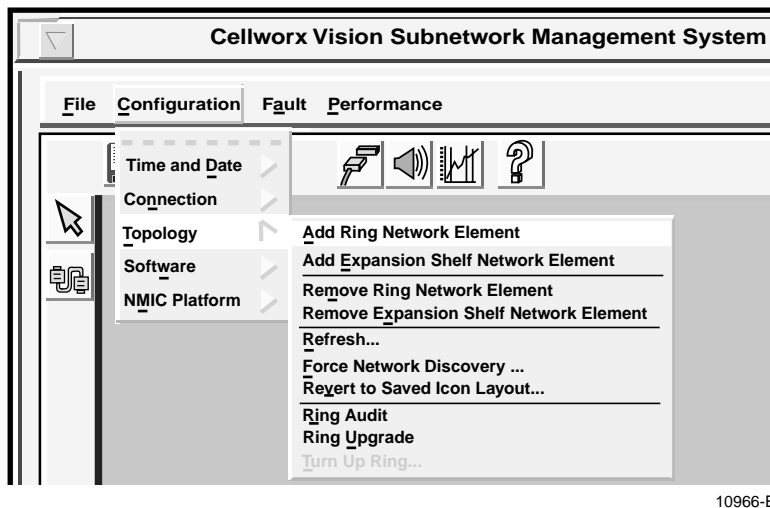
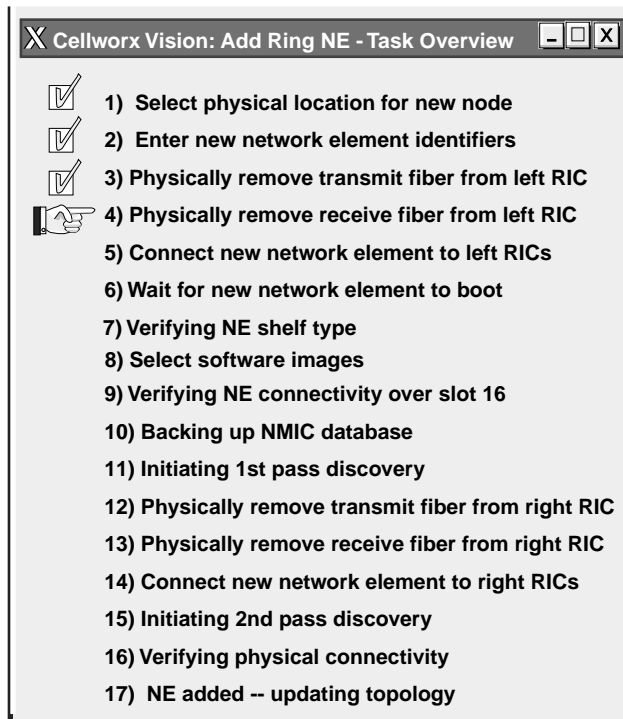
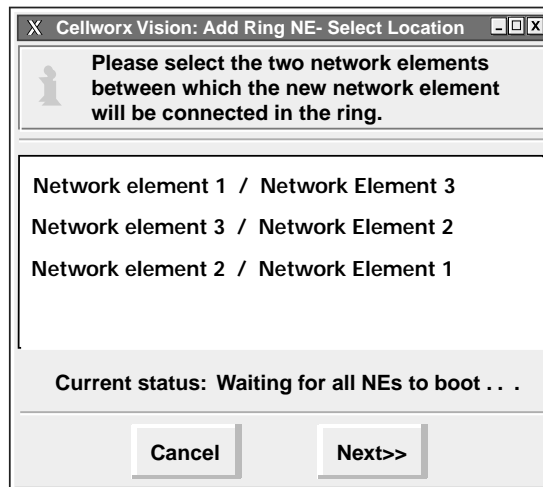

Figure 737-1. Cellworx Vision Configuration Pull Down Menu



11713-D

Figure 737-2. Cellworx Vision Add Ring NE Task Overview



11714-A

Figure 737-3. Cellworx Vision Add Ring NE Select Location Window

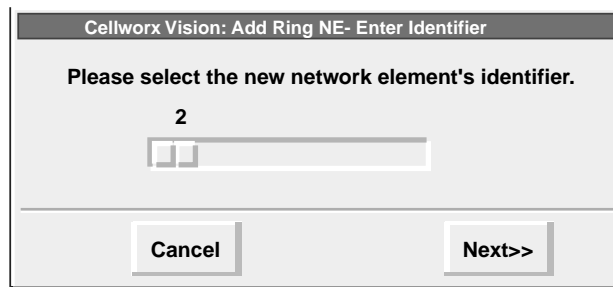

11712-A

Figure 737-4. Cellworx Vision Add Ring NE Enter ID Window

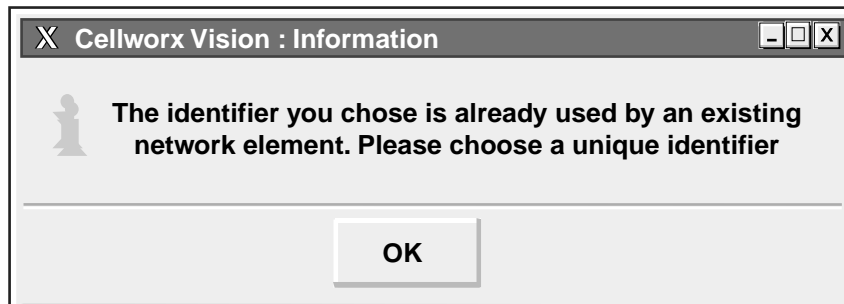

11727-A

Figure 737-5. Cellworx Vision Add NE ID Informational Window

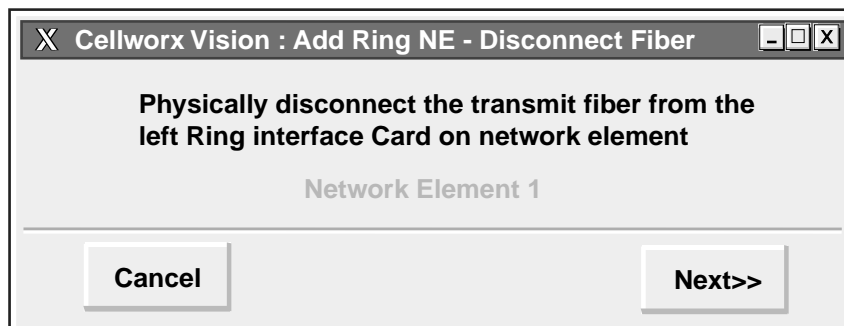

11726-B

Figure 737-6. Cellworx Vision Add Ring NE Disconnect Fibers



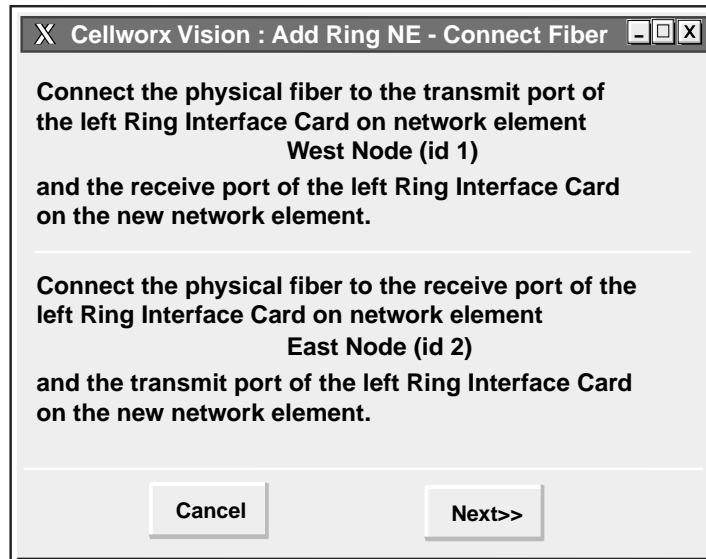

11725-BC

Figure 737-7. Cellworx Vision Add Ring NE Connect New NE Fibers

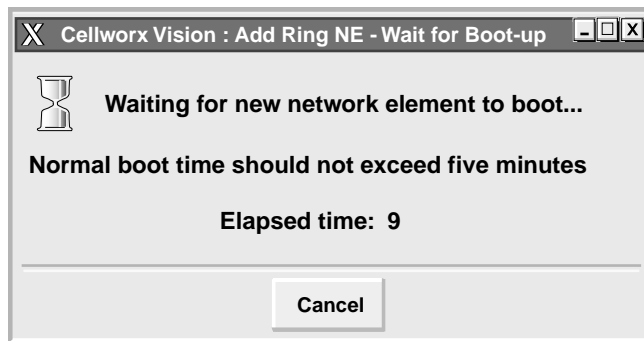

11759-C

Figure 737-8. Cellworx Vision Wait For NE to Boot

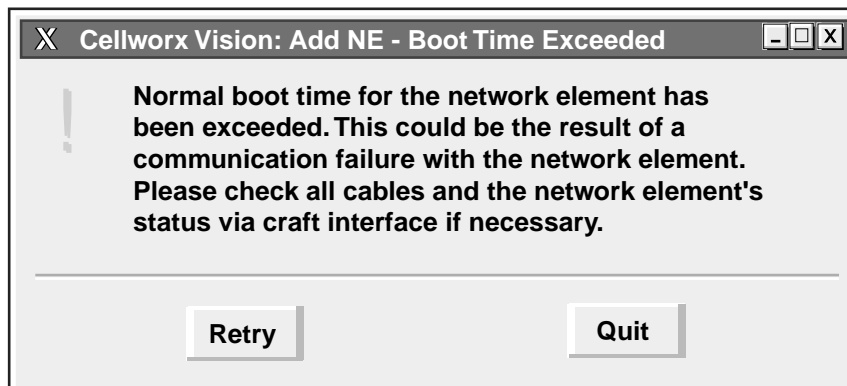

0026-046

Figure 737-9. Add NE Boot Time Exceeded Window

DLP-737  
Page 7 of 8

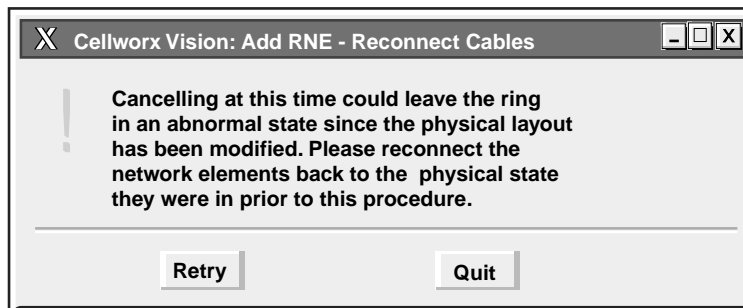

14573-A

Figure 737-10. Add EPS NE - Reconnect Cables Instructional Window

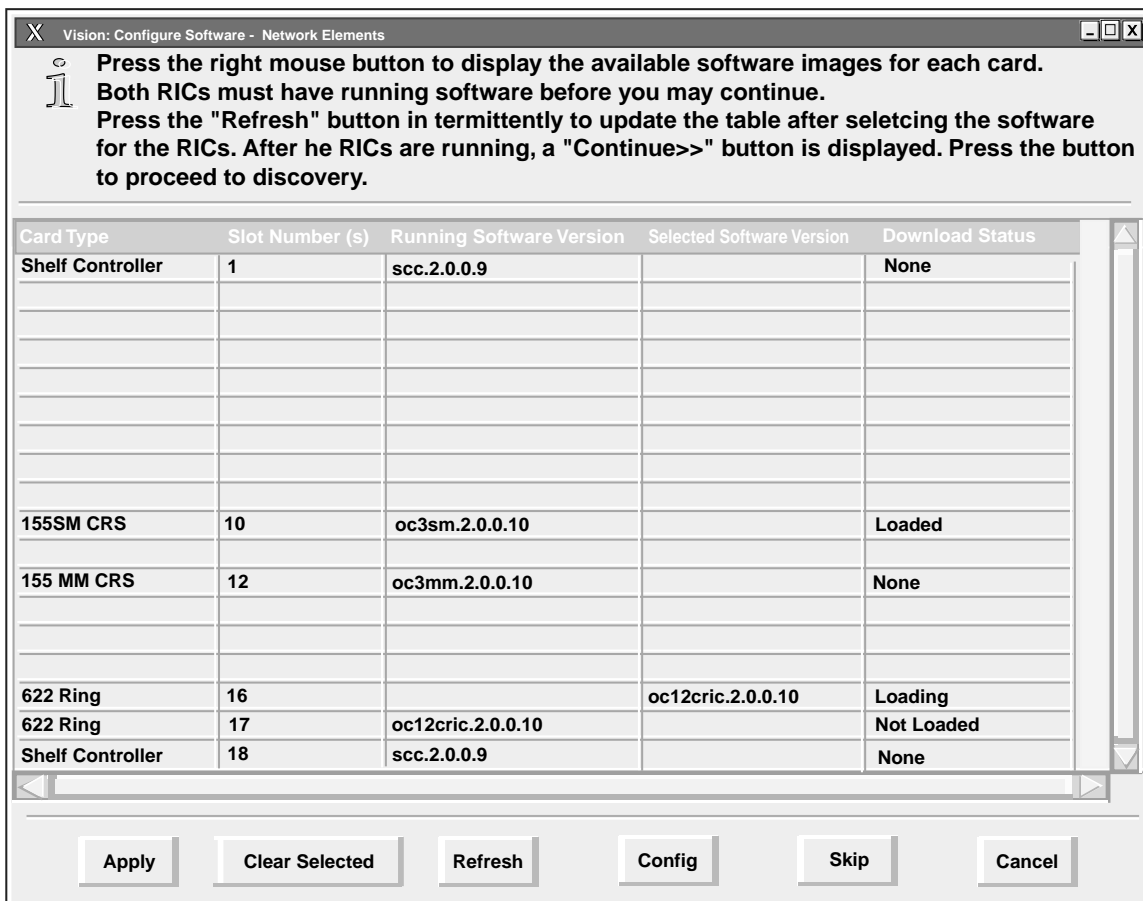

14546-B

Figure 737-11. Cellworx Vision Configure Software Window



11758-A

Figure 737-12. Cellworx Vision Discovering NE Window

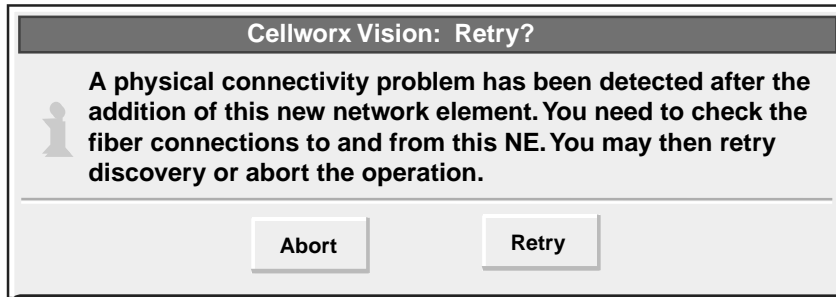

11724-A

Figure 737-13. Cellworx Vision Boot Failure Informational Window



11015-A

Figure 737-14. Cellworx Vision Updating Topology Message Window

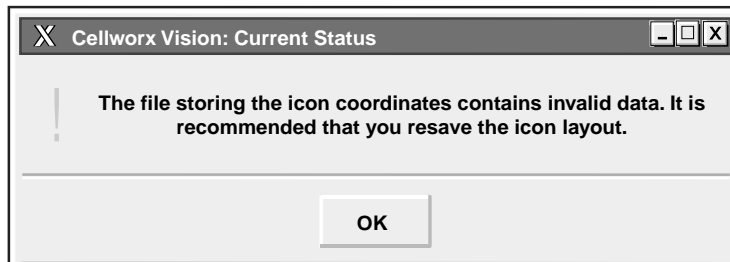

10929-A

Figure 737-15. Cellworx Vision Save Icon Layout Window

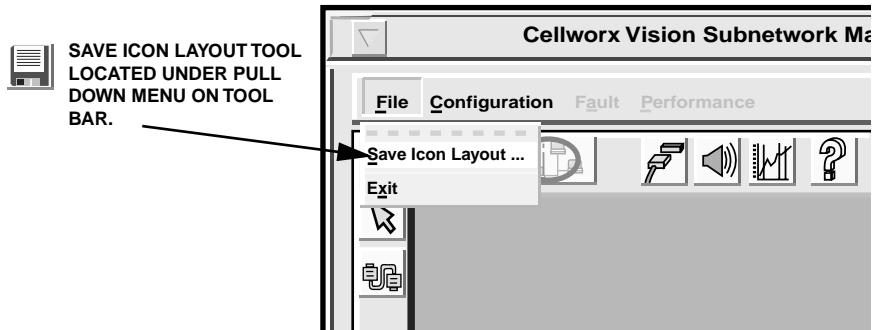

11755-B

Figure 737-16. Cellworx Vision Save Icon Layout Options

**DLP-738**

Page 1 of 7

**ADD A SECOND NETWORK ELEMENT**

**Summary:** This procedure describes the steps required to add a second Cellworx STN node to any existing in service stand-alone NE. The instructions provided by the Cellworx Vision Graphical User Interface (GUI) should be followed precisely to minimize service impact on the upgrade. It is assumed the user has already launched the GUI from the stand-alone node and the required optics have been installed per NTP-004. Verify the correct shelf type setting has been set per the Phase 3.1 Installation manual listed in the preface of this document.

1. From the GUI screen, use the left mouse button to select the **Configuration** pull down menu located above the workspace, and then **Topology** and **Add Ring Network Element**. This can also be accomplished by entering **Alt+C**, **Alt+N**, and **Alt+A**. Refer to Figure 738-1.
2. The Cellworx Vision: Add Second Ring NE - Task Overview window appears as shown in Figure 738-2. The tasks that will be performed are listed in order from 1 to 8 with a pointer indicating the current task. The first task is to enter the NE identifier as another window appears as shown in Figure 738-3. Using the left mouse button, select the slider bar button and move it to the right until the desired ID appears above the bar. In this example a 2 is shown.
3. If an ID is entered that already exists, the message window shown in Figure 738-4 will appear. Select OK and choose another number. Be sure the number selected is the same as the number set on the node via the rotary switches on the protect SC TEIM card.
4. After making the ID selection, choose the Next button. The pointer on the Task Overview window moves to step 2, Connect left RICs (cards in slot 16), and another window appears as shown in Figure 738-5.
5. Follow the instructions for connecting the fibers between the RICs in the left slots of the two nodes, and then select **Next**.
6. Another window similar to Figure 738-5 appears directing the user to connect the other set of fibers between the RICs in the right slots of the two nodes (step 3 of the Task Overview). Follow the instructions and select **Next** once completed.
7. The Task Overview window now indicates that the system is waiting for the new network element to boot (step 4 of the Task Overview) and an informational window appears as shown in Figure 738-6. The NE should boot within sixty seconds. If the boot-up process exceeds sixty seconds, another window prompts the user to retry or quit. Refer to Figure 738-7. Follow the instructions and select either **Quit** or **Retry**. If Quit is selected, the Add NE - Reconnect Cables window appears. Refer to Figure 738-8. Follow the instruction to return the equipment to its original physical state and select **Quit**, otherwise continue.

8. Next the Cellworx Vision software configuration window appears for the new NE, and the Task Overview pointer moves to step 5. Refer to Figure 738-9. At this point the SC card(s) should show a running software image but the RICs will be blank. Follow the instructions at the top of the window to select a software image for the RICs and then hit **Apply**.
9. The Download Status column changes to Loading for both of the RIC cards. This process will take up to four minutes. During this process the user may select the **Refresh** button to update the display.
  - ◆ **Note:** If the screen is refreshed during the RIC software download, the Download Status column will change to None. This is OK. The RICs will continue to boot. Once completed with the boot process, the user must select **Refresh** again to update the Running Software Version column.
10. Upon completion of the software download to both RICs, and the user selecting **Refresh**, both RICs will have a running software version displayed and the **Skip** button at the bottom of the screen is changed to a **Continue** button.
11. Select the **Continue** button. The system now attempts to discover the new NEs, indicated by the pointer on step 9 of the Task Overview window, and the “Discovering Network” message window as shown in Figure 738-10. If a problem is encountered during discovery, the message window shown in Figure 737-11 will appear instructing the user to check fiber connections. The user may then retry the discovery or abort the entire process. See Section 4 of this manual for troubleshooting tips if problems are encountered with the boot up process. A discovery verifies the physical connectivity between the nodes and should take less than ten seconds.
12. The system responds with a message window indicating that it is updating the network topology and to please wait. Refer to Figure 738-12.
13. The user will be prompted to save the new icon layout. Refer to Figure 738-13. To do this, select the disk icon on the tool bar above the work area or select the **File** pull down menu and **Save Icon Layout** or by entering **Alt+F** followed by an **Alt+S** on the keyboard. Refer to Figure 738-14.

**Stop! You have completed this procedure.**

DLP-738  
Page 3 of 7

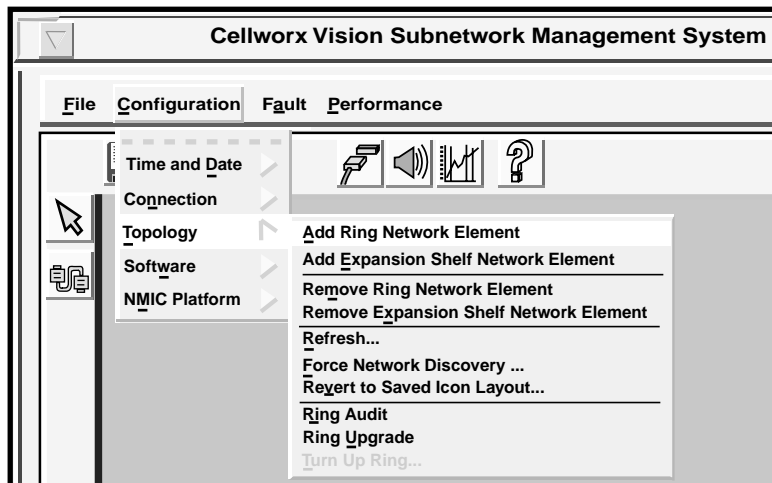

10966-E

Figure 738-1. Cellworx Vision Configuration Pull Down Menu

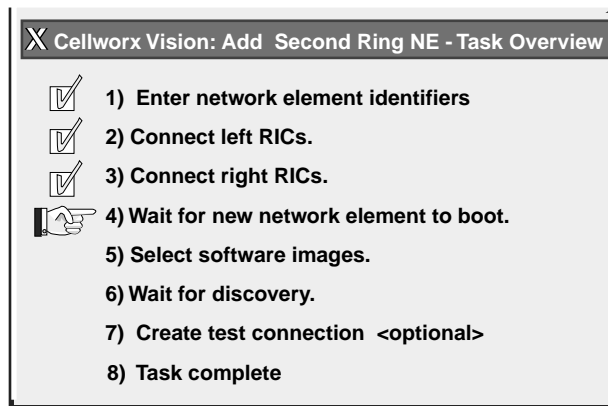

11710-A

Figure 738-2. Cellworx Vision Add Second Ring Task Overview Window

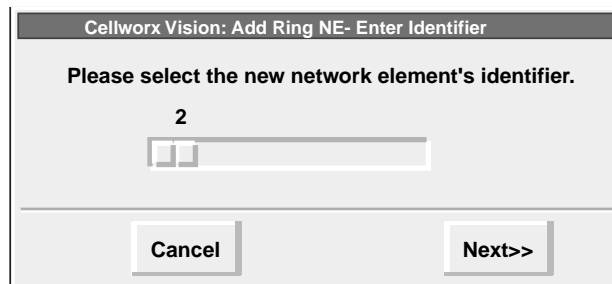

11712-A

Figure 738-3. Cellworx Vision Add Ring NE Enter ID Window

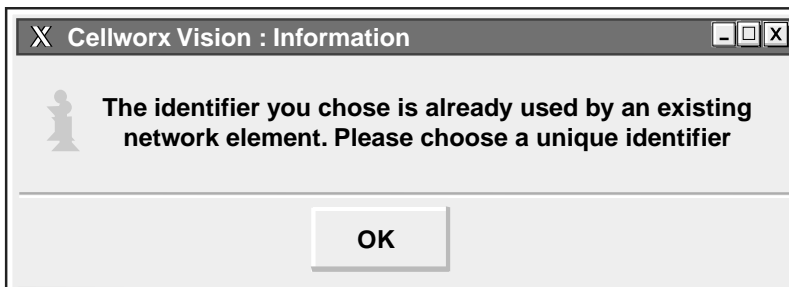

11727-A

Figure 738-4. Cellworx Vision Add NE ID Informational Window

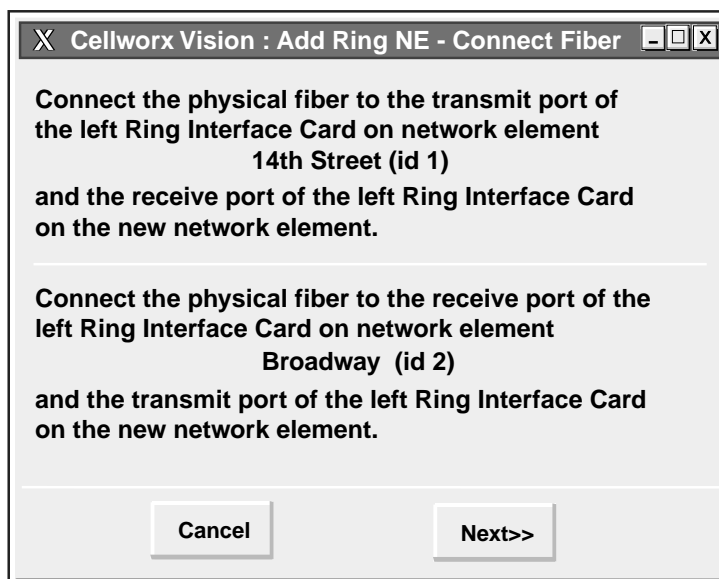

11912-B

Figure 738-5. Cellworx Vision Add Ring NE Connect Fiber

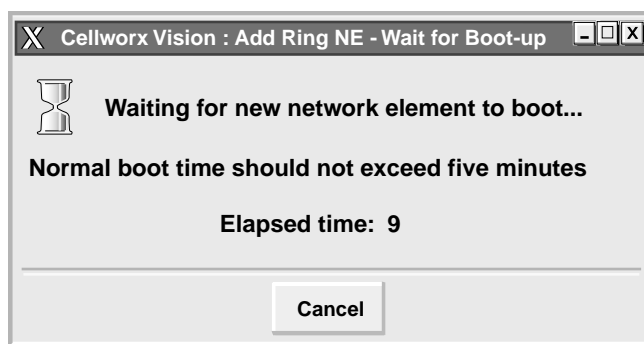

11759-C

Figure 738-6. Cellworx Vision Wait For NE to Boot

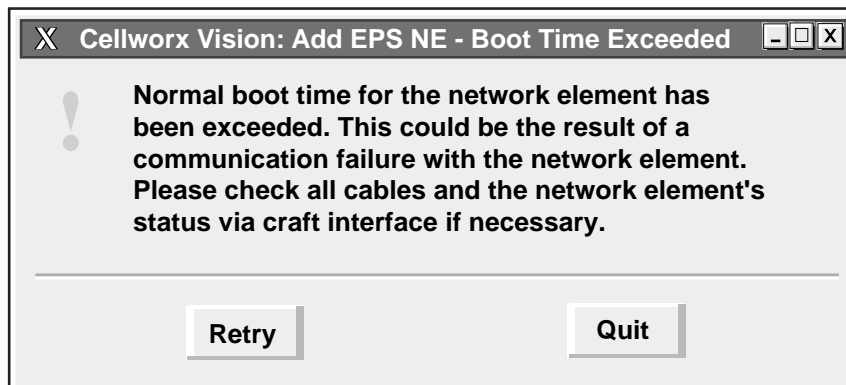

10888-A

Figure 738-7. Add NE Boot Time Exceeded Window

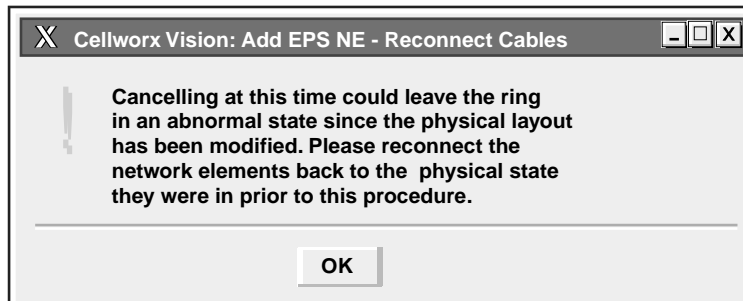

10892-C

Figure 738-8. Add EPS NE - Reconnect Cables Instructional Window



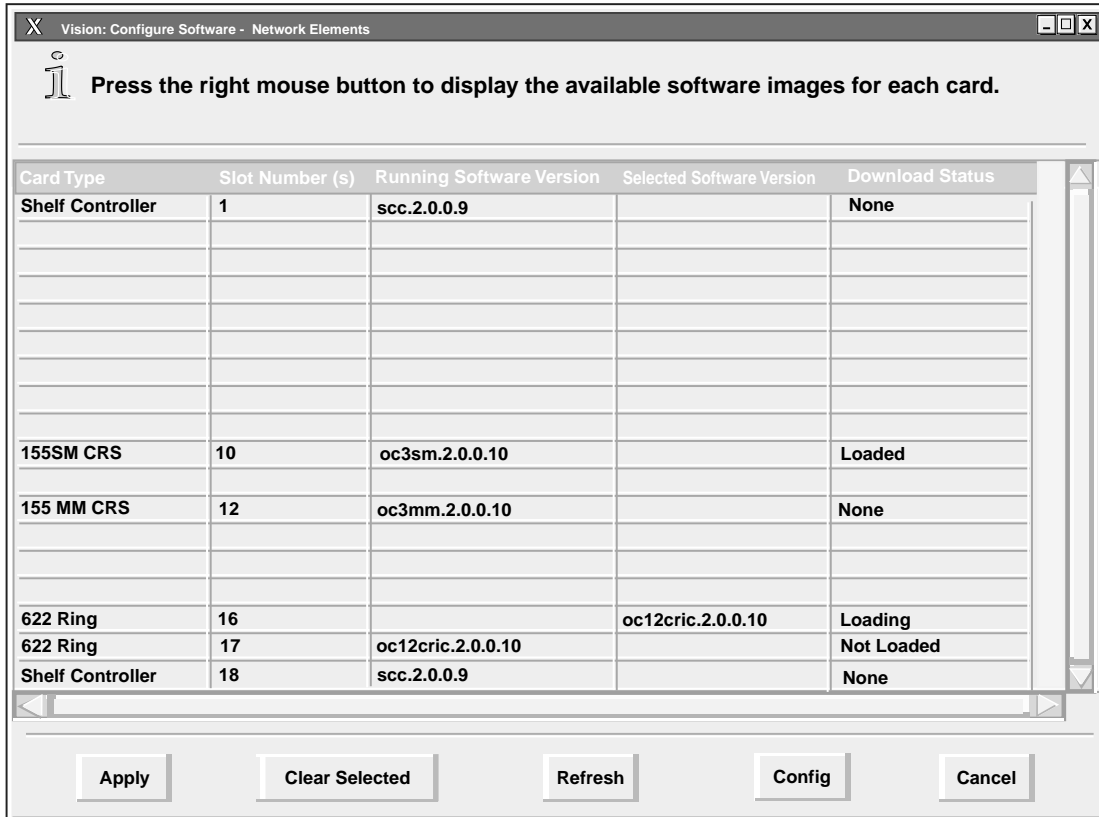

11717-D

Figure 738-9. Cellworx Vision Configure Software Window

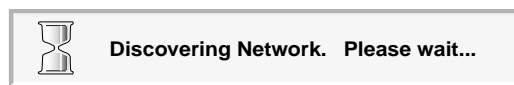

11758-A

Figure 738-10. Cellworx Vision Discovering NE Window

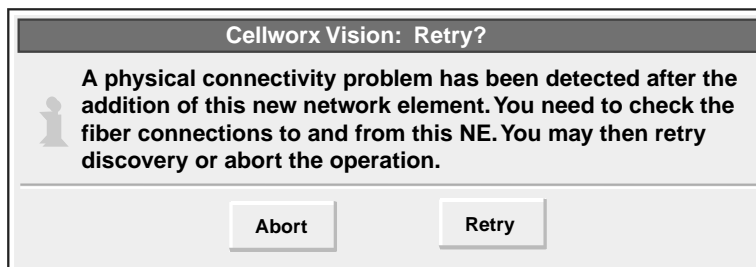

11724-A

Figure 738-11. Cellworx Vision Boot Failure Informational Window

DLP-738  
Page 7 of 7



11015-A

Figure 738-12. Cellworx Vision Updating Topology Message Window

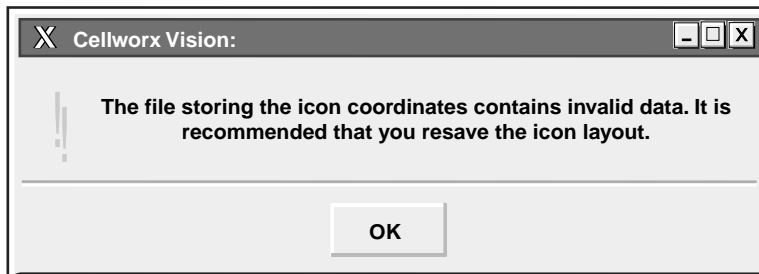

10929-B

Figure 738-13. Cellworx Vision Save Icon Layout Window

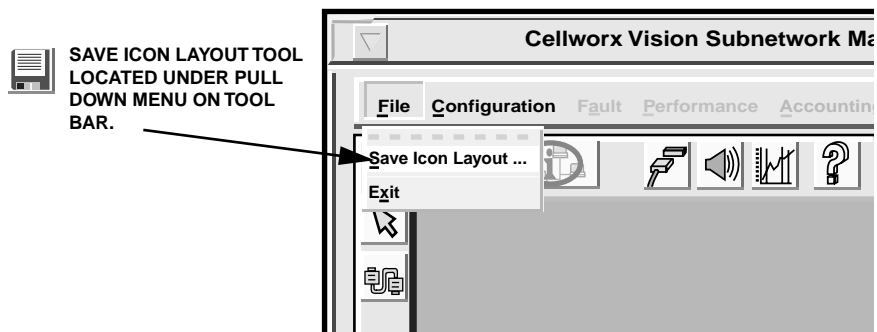

11755-A

Figure 738-14. Cellworx Vision Save Icon Layout Options

## DELETE CONNECTIONS

**Summary:** This procedure describes the steps necessary to successfully navigate the Cellworx Vision Graphical User Interface to view the established connections at a node and delete them.

1. Access the Subnetwork Connection Filter window using the left mouse button to select **Configuration**, **Connection**, and **View** (or using the direct selection keys, **Alt+C**, **Alt+N**, then **Alt+V**). Refer to Figure 739-1.
2. The Subnetwork Connection Filter window appears. Refer to Figure 739-2. If not already displayed, select the **Connection** tab and click on **ATM VP-ATM VP**, **ATM-VC-ATM VC**, **CES-ATM VC**, **CES-CES**, **FR-ATM VC**, **FR-FR**, **ATM VP Multicast**, or **ATM Bundled VC Multicast** using the left mouse button.
3. Select the **Network** tab, which displays all NEs in the network, and select the NE that has the connection being deleted. Click on the >> button using the left mouse button which will move the highlighted NE to the selected box. Refer to Figure 739-3.
4. Select the **Traffic** tab, which displays all available traffic contracts that can be specified for the connection retrieval. Click on the **All>>** button using the left mouse button to choose all traffic contracts.
5. Select the **ATM** tab which displays all ATM ports in the network and click on the **All>>** button.  
  
◆ **Note:** The user may optionally select the “**Retrieve All**” button instead.
6. Once all information is selected for the NE, select **Apply** using the left mouse button.
7. The Subnetwork Connections window appears as shown in the example in Figure 739-4. The status column indicates the most current information for the connection. The status may be listed as Incomplete, Functional, or an Unknown State. Up to 100 entries may be viewed per page by using the up and down slide button on the right side of the window. If more than 100 entries are available for viewing, the user may use the Page slide button at the top right corner of the window to select additional pages. Select the traffic connections one at a time or multiple connections using the Ctrl or Shift key plus using clicking the left mouse button on the desired connections, followed by the **Delete** button at the bottom center of the window. When selected, the line or lines the connection(s) is displayed on will become highlighted.
8. After selecting **Delete**, a confirmation message appears as shown in Figure 739-5. which requires the user to select **OK** or **Cancel**. If a problem exists with the hardware between the NMIC and the endpoints shelf controllers, a denial message will appear stating the reason the connection could not be deleted. Refer to the TAP section of this document for any error reports.

DLP-739  
Page 2 of 4

► **Note:** Existing traffic contracts may be used for other connections and cannot be deleted until all connections using the contract have been deleted.

**Stop! You have completed this procedure.**

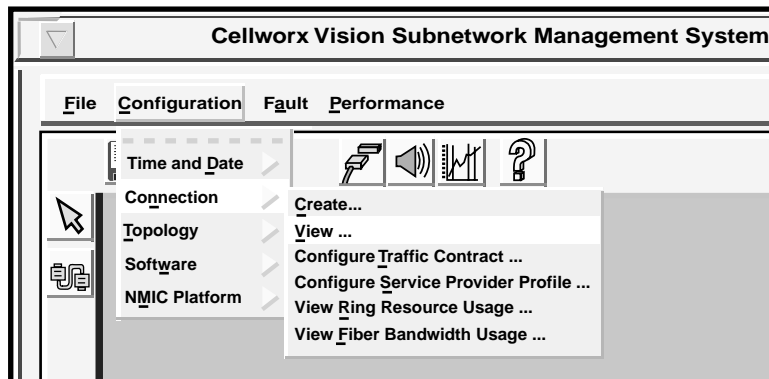

10963-D

Figure 739-1. Cellworx Vision Connection Menu Tree

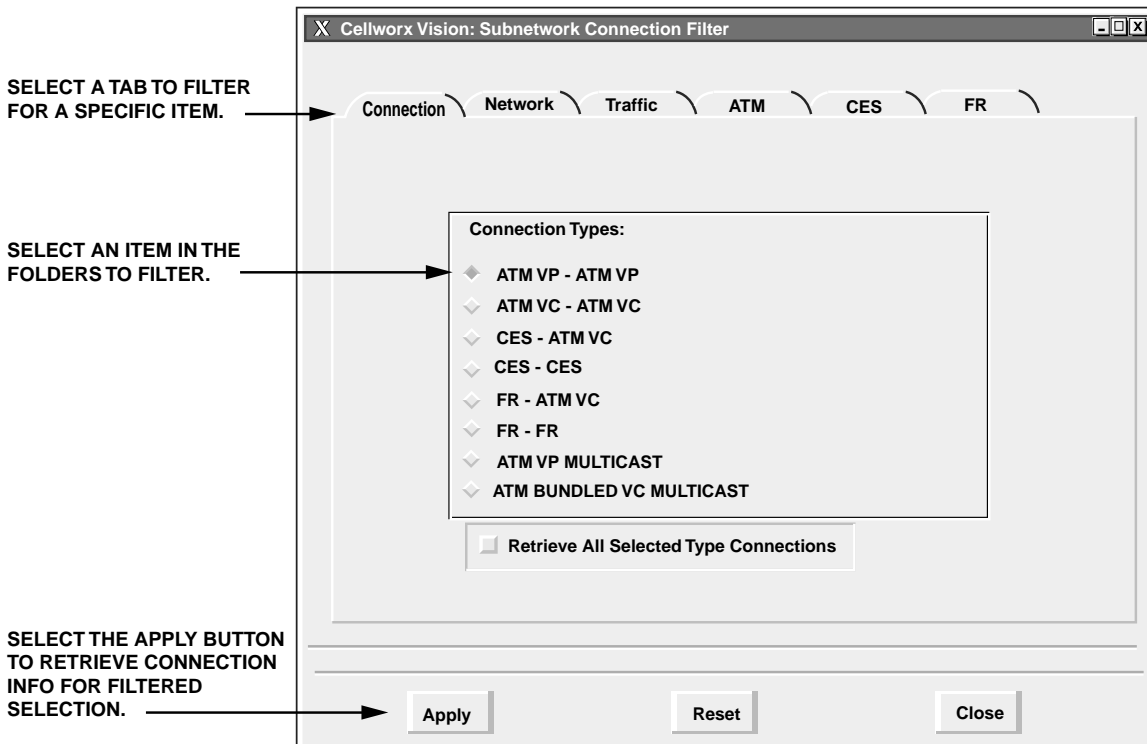

11000-F

Figure 739-2. Subnetwork Connection Filter Window

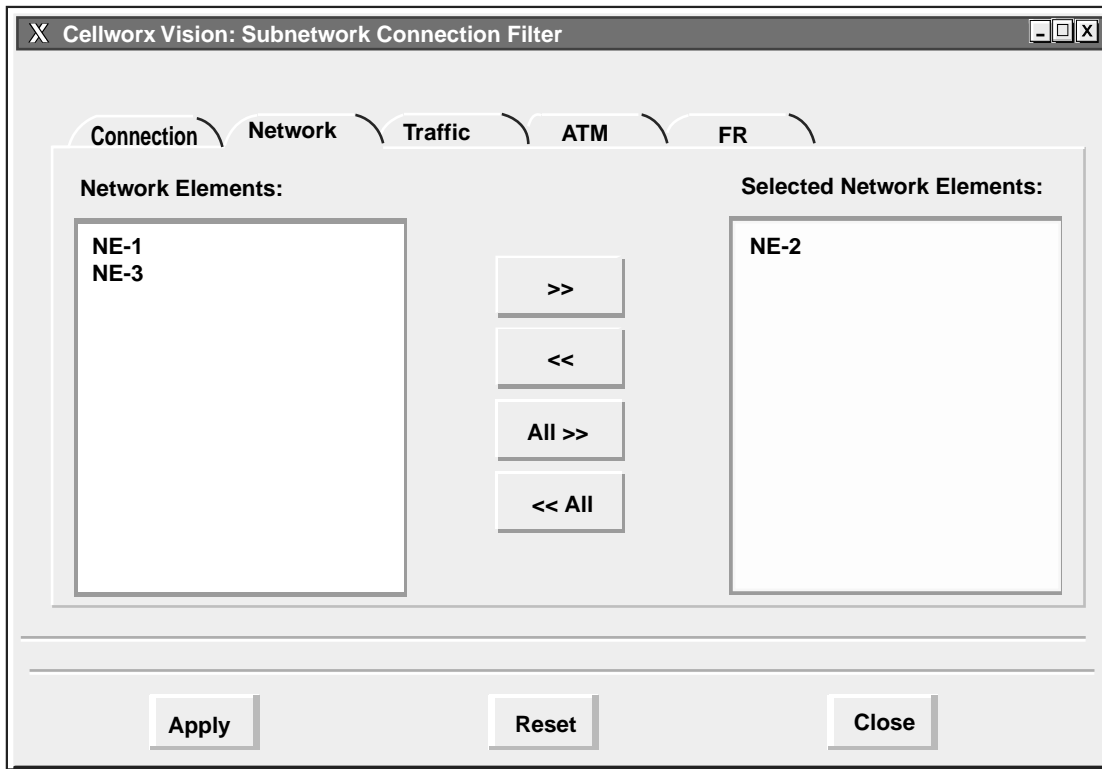

10999-C

Figure 739-3. Subnetwork Connection Filter Window - Network



## DELETE A CELLWORX STN NODE

**Summary:** This procedure describes the steps necessary to successfully delete a Cellworx STN node from the system database. Pre-requisites of this procedure are:

- The user should have gained access to the Cellworx STN system and have launched the GUI.
  - All connections to the NE that is being removed from the system database should have all connections deleted.
1. Select the node to be deleted using the left mouse button. A white ring surrounds the node.
  2. Access the Remove Ring NE Task Overview window using the left mouse button to select **Configuration**, **Topology**, and **Remove Ring Network Element** (or using the direct selection keys, **Alt+C**, **Alt+T**, then **Alt+M**). Refer to Figure 740-1.
  3. The task overview window appears as the system checks for existing connections. Refer to Figure 740-2. Step 2 of the task overview brings up a window instructing the user to disconnect the transmit fiber from the left RIC of the next NE in the network (ID will be displayed). Refer to Figure 740-3. The left RICs are installed in slot 16. Follow the instructions for disconnecting the fiber and select the **Next >>** button.
  4. Step 3 of the task overview instructs the user to disconnect the receive fiber from the left RIC (slot 16) of the previous NE in the network. This isolates the NE being removed from the inner fiber route of the network and leaves the traffic flowing through the NE in the outer direction. Follow the instructions to remove the fiber and select the **Next >>** button.
  5. Step 4 of the task overview instructs the user to reconnect the transmit fiber of the next NE to the receive fiber of the previous NE in the network thus restoring the ring inner fiber connections. Refer to Figure 740-4. Follow the instructions and select the **Next >>** button.
  6. The system forces all traffic on the ring to the inner fiber direction so the previous steps may be repeated on the outer ring fibers between the NE being removed and the previous and next NEs in the network. The system prompts the user to remove the fibers from the right RICs in slot 17 of the NEs with windows similar to Figures 740-3, and reconnect them to each other similar to the window in Figure 740-4 (tasks 5 to 7). Follow the instructions for each window and select the **Next >>** button on each window to continue.
  7. The system restores the ring traffic over both fibers and begins discovering the physical ring connectivity (step 8). Once the software verifies all physical fiber connections, the task is completed.
  8. When the NE removal is completed, the system draws the new ring configuration on the screen according to its connectivity. To redraw the icon layout before saving the default system layout, select the arrow tool on the toolbar on the left side of the screen, click on and drag the NEs to the desired position on the screen, and release the mouse button. See Figure 740-5. This does not change the physical connectivity between the nodes.

## DLP-740

Page 2 of 5

9. The Icons now stay positioned in the new locations and maintain the highlighted connection between them. This capability enables the user to group NEs that may be collocated, or separate them according to their geographical locations. The user may also return the icons to their original positions on the screen by selecting the *Configuration* pull down menu, *Topology*, and *Revert to Saved Icon Layout* or *Alt+C*, *Alt+T*, and *Alt+V*. Refer to Figure 740-6.
10. To save the new icon layout displayed on the screen, select *File* and *Save Icon Layout* (*Alt+F* and *Alt+S*), or use the diskette icon on the tool bar. See Figure 740-7.
11. The confirmation window appears as shown in Figure 740-8. Select *OK*. The newly drawn icon layout will remain this way each time the GUI is launched, until the layout is redrawn and saved again.

**Stop! You have completed this procedure.**

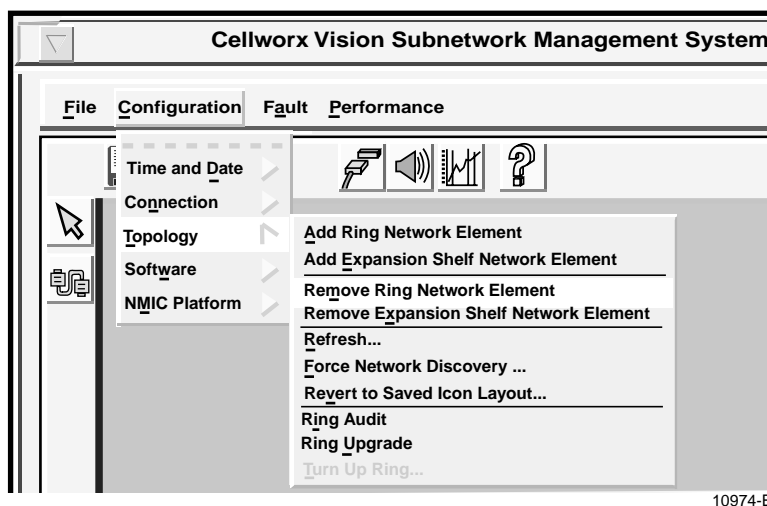
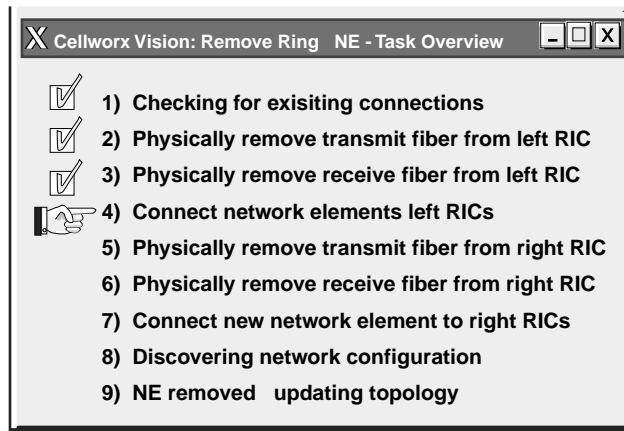

Figure 740-1. Cellworx Vision Remove Ring NE Pull Down Menu





11752-C

Figure 740-2. Cellworx Vision Remove Ring NE Task Overview

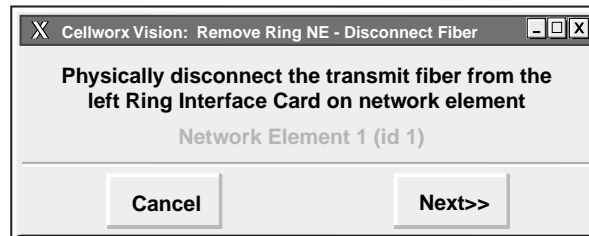

11920-B

Figure 740-3. Cellworx Vision Remove Ring NE Fiber Instructional Window

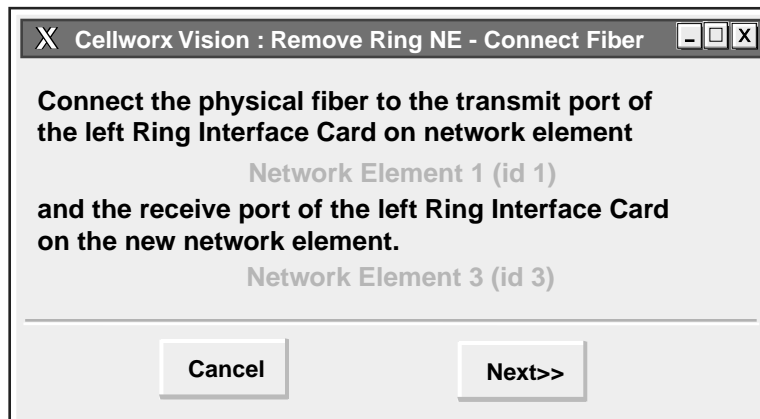

11753-B

Figure 740-4. Cellworx Vision Connect Ring NE Fibers Instructional Window

DLP-740  
Page 4 of 5

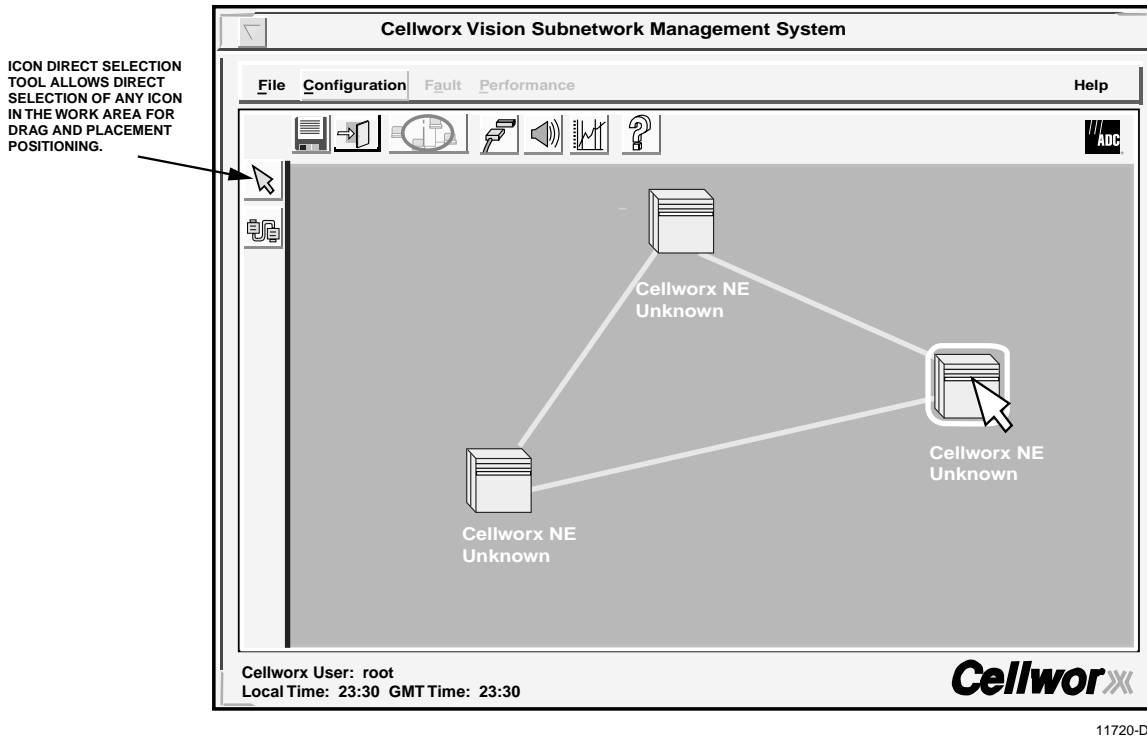

Figure 740-5. Cellworx Vision Redrawing ICON Layout

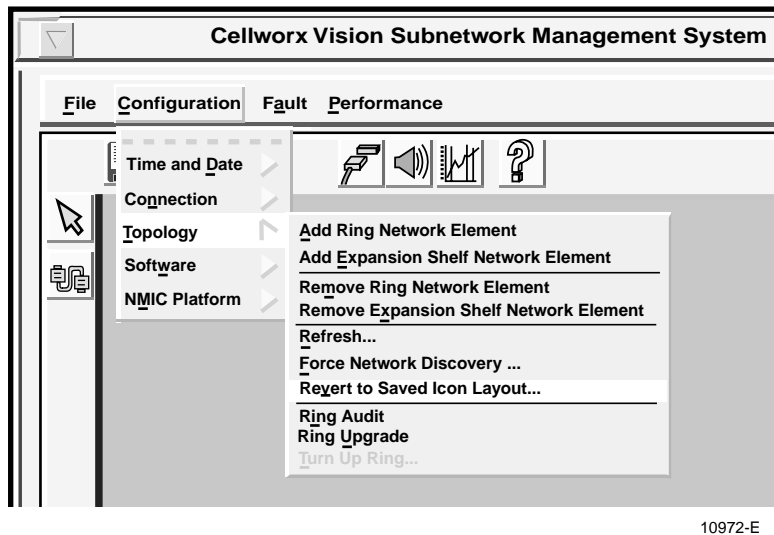

Figure 740-6. Cellworx Vision Revert to Saved Icon Layout Pull Down Menu

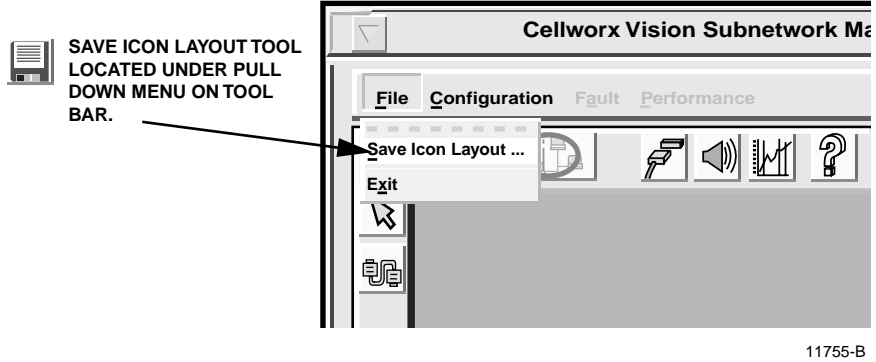

Figure 740-7. Save New Icon Coordinates

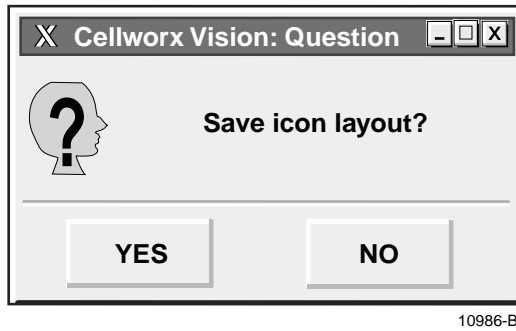

Figure 740-8. Save Icon Layout Confirmation

**DLP-741**

Page 1 of 2

**RETRIEVE LOGS FROM THE NMIC VIA FTP**

**Summary:** This procedure outlines the steps involved for retrieval of the log files stored on the NMIC for performance, accounting, and alarm history. Log files are automatically updated every fifteen minutes to the NMIC hard drive and are stored for a 24-hour period. The files can be retrieved via FTP to a remote management workstation and stored indefinitely on user medium (i.e. hard disk, floppy disk, tape backup, etc.). This procedure is based on a standard UNIX FTP program. For other FTP programs, substitute the standard commands with your particular system “command gets”.

It is assumed that the user will be performing backup of some of this data regularly, generally every 24 hours. This procedure also assumes the user has gained access to the NMIC via FTP and has logged on.

► **Note:** Direct access to the files may be entered in one Unix string but for this procedure we will select one file structure at a time to familiarize the user with the Unix file locations. For direct access and FTP of the files, go to step 5.

1. First, establish an FTP session with the NMIC using the correct IP address for the desired network. A login prompt should appear requiring the user to enter the correct user name and password.
2. To access the files scheduled for back up, change to the cellworx directory on the NMIC using the following command:

- **cd /cellworx**

3. Listed under the cellworx directory are files titled “performance”, “alarmHistory”, and “accounting”. Select the log type that you wish to access by entering the following command substituting file name with accounting, alarmHistory, or performance:

- **cd /cellworx/<file name>**

4. The file contents can be displayed by typing “ls” for list or “dir” for directory. The content of the files are as follows:
  - **Performance** – captures all performance monitoring data from each NE in the network every fifteen minutes. Performance data includes error counts and cells discarded for any interface in the node.
  - **Alarm History** – captures all alarm history data for each NE in the network. Alarm history includes any alarm conditions (performance, physical failures, housekeeping, etc.), that have been incurred or cleared during each fifteen-minute log period for each NE in the network.
  - **Accounting** – captures all accounting data for each NE in the network. The largest part of this is NDC (Network Data Collection), which includes ingress cells passed, egress cells passed, etc.

5. Under the log types, the user may select an NE targeted for backup from the list provided by typing “ls”. The Unix string should now appear similar to this:
  - **cd /cellworx/performance/nex**  
(x = the number the user has assigned to the NE).
6. Under the NE log file for any of the selected log types, is a list of every fifteen-minute log recorded by the NMIC for the last 24 hours. A list of logfiles can be displayed by entering “ls” (list). Select the logfile for the time period desired for ftp by entering for example;
  - **prompt** (this disables the system from prompting the user for confirmation of every file encountered)
  - **mget /cellworx/performance/ne2/XXXXXX**  
(x = the specific file name for the NE).
7. The user can ftp the files selectively or by using wildcard strings to retrieve the all files. For example to ftp all the performance logs for NE 3 the user would type;
  - **mget /cellworx/performance/ne3/\***
8. To get the accounting data for all the NEs, user would type;
  - **mget /cellworx/accounting/\*/\***
9. Refer to Figure 741-1 for file structures.

**Stop! You have completed this procedure.**

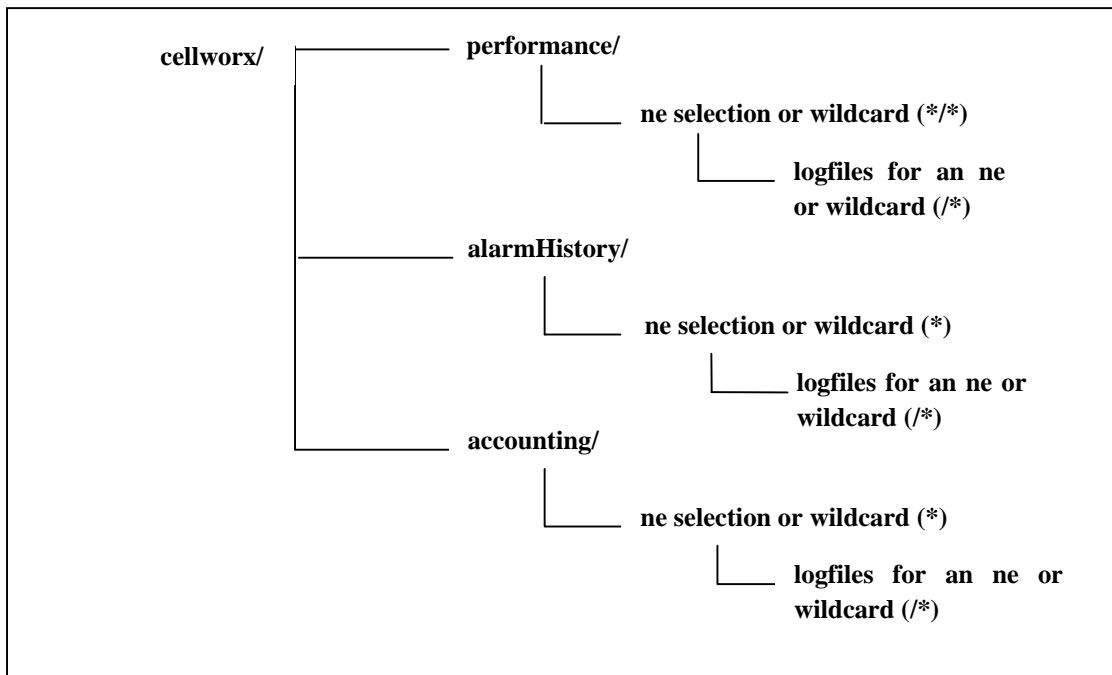

Figure 741-1. NMIC Logfiles, UNIX Menu Structure

**DLP-742**

Page 1 of 3

**RETRIEVE COMPRESSED LOGS FROM THE NMIC VIA FTP**

**Summary:** This procedure outlines the steps involved to compress and then retrieve the log files stored on the NMIC for performance, accounting, and alarm history. Log files are automatically updated every fifteen minutes to the NMIC hard drive and are stored for a 24-hour period. The files can be retrieved via FTP to a remote management workstation and stored indefinitely on user medium (i.e. hard disk, floppy disk, tape backup, etc.). This procedure is based on a standard UNIX FTP program. For other FTP programs, substitute the standard commands with your particular system “command gets”. The retrieved files will be in a compressed format. GZIP or WINZIP will unarchive these files.

It is assumed that the user will be performing backup of some of this data regularly, generally every 24 hours. This procedure also assumes the user has gained access to the NMIC via FTP and has logged on.

► **Note:** Direct access to the files may be entered in one Unix string but for this procedure we will select one file structure at a time to familiarize the user with the Unix file locations. For direct access and FTP of the files, go to step 5.

1. First, establish a TELNET session with the NMIC using the correct IP address for the desired network, or establish a CRAFT session with the RS232 DB9 on the front of the NMIC. A login prompt should appear requiring the user to enter the correct user name and password e.g. userid=root with no password.
2. To access the files scheduled for back up, change to the cellworx directory on the NMIC
  - **cd /cellworx.**
3. Listed under the cellworx directory are files titled “performance”, “alarmHistory”, and “accounting”. The content of the files is as follows:
  - **Performance** – captures all performance monitoring data from each NE in the network every fifteen minutes. Performance data includes error counts and cells discarded for any interface in the node.
  - **Alarm History** – captures all alarm history data for each NE in the network. Alarm history includes any alarm conditions (performance, physical failures, housekeeping, etc.), that have been incurred or cleared during each fifteen-minute log period for each NE in the network.
  - **Accounting** – captures all accounting data for each NE in the network. The largest part of this is NDC (Network Data Collection), which includes ingress cells passed, egress cells passed, etc.

4. Type the following command to create the first archive for the Performance data. Note you should be in the /cellworx directory. You can determine this by typing “pwd”. Also note there is a date in the middle of the file name (050500). Change this date to reflect the date the command is being run on.

- **tar -zcvf /tmp/perf\_050500.tar.gz performance**

5. Type the following command to create the first archive for the Alarm History data. Note you should be in the /cellworx directory. You can determine this by typing “pwd”. Also note there is a date in the middle of the file name (050500). Change this date to reflect the date the command is being run on.

- **tar -zcvf /tmp/alarm\_050500.tar.gz alarmHistory**

6. Type the following command to create the first archive for the Accounting data. Note you should be in the /cellworx directory. You can determine this by typing “pwd”. Also note there is a date in the middle of the file name. Change this date to reflect the date the command is being run on.

- **tar -zcvf /tmp/accounting\_050500.tar.gz accounting**

7. If you choose you can type the following commands to see the files that were created in steps 4, 5, and 6.

- **ls -la /tmp/\*.tar.gz**

8. At this point the files /tmp/perf\_050500.tar.gz, /tmp/alarm\_050500.tar.gz, and /tmp/accounting\_050500.tar.gz have been created. Establish an FTP session with the NMIC using the correct IP address for the desired network.

- **ftp <NMIC IP address>**

9. A login prompt should appear requiring the user to enter the correct user name and password e.g. userid=cellworx, password=cellworx#1. The account cellworx is by default already on the NMIC but any user account except the root user account may be used.

10. Enter the following commands:

- **ftp> bin** (to set transfer to binary mode)
- **ftp> prompt** (this disables the system from prompting the user for confirmation of every file encountered)
- **ftp> hash** (turn on the hash marks for progress indication)

## DLP-742

Page 3 of 3

11. Change directory to where the archives are kept.

- `ftp> cd /tmp`

13. Retrieve the archives using the multiple get command as follows:

- `ftp> mget *.tar.gz`

14. Delete the files on the NMIC once the FTP process is complete. Each file must be deleted individually so one command will be issued per file using the following commands:

- `ftp> delete perf_050500.tar.gz`

- `ftp> delete alarm_050500.tar.gz`

- `ftp> delete account_050500.tar.gz`

15. End your FTP session by typing the following command.

- `ftp> quit`

16. On your local host you should have the files: perf\_050500.tar.gz, account\_050500.tar.gz, and alarm\_050500.tar.gz.

**Stop! You have completed this procedure.**



**DLP-743**  
**Page 1 of 1**

**This page intentionally left blank.**

## DLP-744

Page 1 of 2

### REFLASH BOOT IMAGE

**Summary:** The following procedure instructs the user in how to properly “reflash” the boot image on cards after loading new feature sets. With each new release, new features and bugs are fixed in the non-volatile flash of a card. This flash must be upgraded, similar to upgrading the application code when going from P2.0 to P3.1. The customer will need to flash the image in the following scenarios:

- Major software upgrade has been performed and there is a new bootrom
  - Receives a card from manufacturing and it does not contain the correct bootrom version for the software version they are running
1. From the GUI main menu, select the NE in question using the right mouse button.
  2. The NE Pop-up window appears as shown in Figure 744-1. Select the **Reflash Boot Image** option using the left mouse button.
  3. The Reflash Boot Image selection window appears displaying each card in the chassis. Refer to Figure 744-2. Place the cursor on the line of the card to be changed or updated and using the right mouse button, click and hold the mouse button on that line.
  4. The available software reflash images will be displayed. While continuing to hold the mouse button down, drag the cursor to the desired image and release the mouse button. The selected reflash image is moved to the Selected column.
  5. Repeat steps 3 and 4 for each card in the shelf.
  6. Select the **Apply** button to initiate the card(s) reflash. This process may take several minutes per card.
  7. Select the **Refresh** button to update the Download Status column. This Download Status column will show “Loading” until the image is loaded at which time it will display “Loaded”.
  8. After the correct boot image is completely loaded, select the **Cancel** button to close the window.
  9. Perform a card reset per DLP-773 on each card changed to ensure the latest flash code is running.

**Stop! You have completed this procedure.**

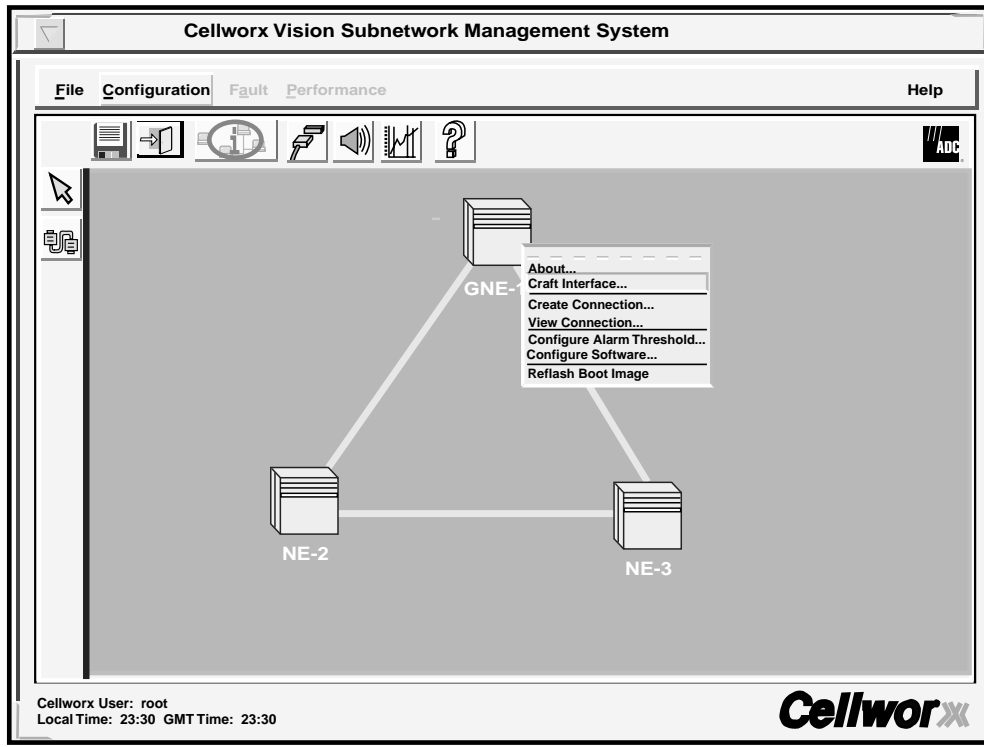

10942-F

Figure 744-1. NE Pop-up Window

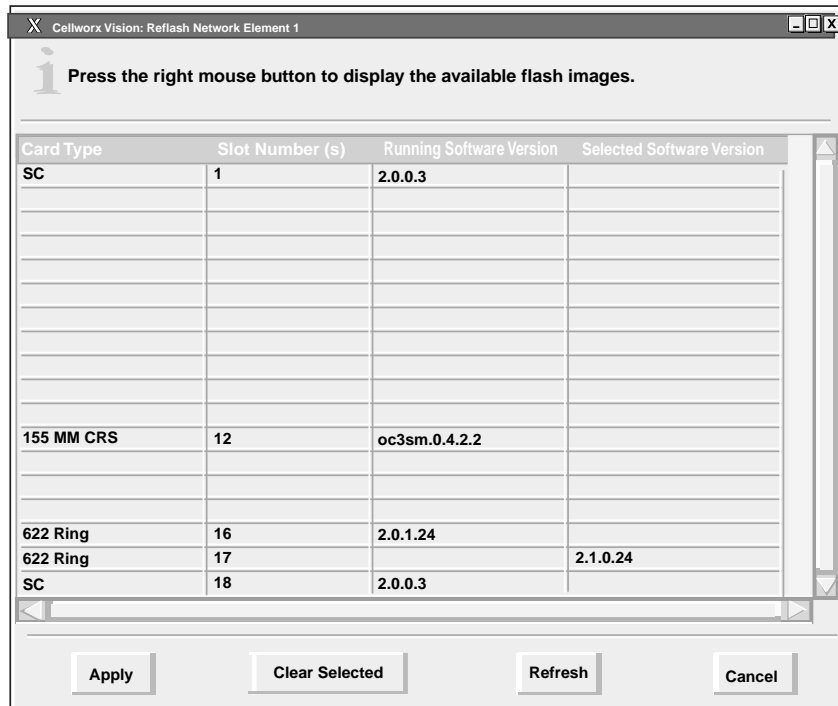

0026-045

Figure 744-2. Reflash Boot Image Selection Screen

**DLP-745**

Page 1 of 2

**SAVING THE SYSTEM DATABASE**

**Summary:** This procedure defines the steps involved with saving the current system database and should be used by those with UNIX/LINUX knowledge. While NMIC protection provides a great deal of security against losing the system database in the event of a NMIC failure, it is still a good practice to save the current database after the system has been placed in a useful state. This will protect the user from the remote possibility of database corruption on both NMICs, and allows the user to fallback to a known system state rather than falling back to a default system state and requiring rediscovery of the ring.

**SAVING SYSTEM DATABASE**

- **Note:** The NMIC database should be stored in two locations, locally on the NMIC in a directory, and remotely on another system storage device.

1. The system database consists of the following files on the NMIC:

- `/cellworx/config/NE.*` -where \* is a wildcard representing the number of each NE in the system. This will also make a copy of the default template for creating NEs.
- `/cellworx/config/NMIC`

**Example:** If the system is a three node ring with one expansion shelf using NE1, NE2, NE3, and NE4, then the entire database would consist of the following five files;

- `/cellworx/config/NE.1`
- `/cellworx/config/NE.2`
- `/cellworx/config/NE.3`
- `/cellworx/config/NE.4`
- `/cellworx/config/NMIC`

**BACKING UP A COPY OF THE NMIC DATABASE**

2. Telnet to the active NMIC using the floating IP address or the NMIC specific IP address for the currently active NMIC.
3. Enter the following command to change to the directory where the database files are stored.

- `cd /cellworx/config`

4. The following command will copy the NMIC database files to the NMIC.backup file where they can be accessed at a later time.

- **cp NMIC NMIC.backup**

5. Create a directory named /cellworx/config/saved on the NMIC and copy the relevant database files into the saved directory for potential use later.
6. Additionally, it is recommended that the database files should be FTP'ed off of the NMIC and onto another system in the event that there are problems with the NMIC hard drive.

**DLP-746**

Page 1 of 3

**DELETE A CELLWORX STN EXPANSION SHELF (EPS)**

**Summary:** This procedure details the steps required to delete a Cellworx STN shelf that is currently being utilized in a network as an expansion shelf (STN-EPS). The user should ensure all connections to the EPS NE are deleted before attempting this procedure.

1. Select the NE to be deleted using the left mouse button. A white ring surrounds the NE.
2. Access the Remove EPS NE Task Overview window using the left mouse button to select *Configuration*, *Topology*, and *Remove Expansion Shelf Network Element* (or using the direct selection keys, *Alt+C*, *Alt+T*, then *Alt+X*). Refer to Figure 746-1.
3. The task overview window appears as shown in Figure 746-2 and the system requests verification that this task is to be initiated. Refer to Figure 746-3. Click on *Yes* in the confirmation window to continue or *No* to abort this procedure.
4. Step 1 indicates that the system is checking for any existing connections terminating at the EPS. If any connections are found, the user must first delete them before continuing. Refer to DLP-739 to delete connections.
5. Step 3 of the task overview instructs the user to reconfigure the EPS and RNE interfaces as non-SEPIs (Shelf Expansion Interfaces). Refer to Figure 746-2. Use the following procedures for changing the configuration on the appropriate SEPI(s):
  - T3 Card Configuration DLP-753
  - 155 CRS Card Configuration DLP-752
  - 622 CRS Card Configuration DLP-797
6. Select the *Next>>* button to continue with the procedure after reconfiguring the SEPIs.
7. Step 4 of the Task Overview indicates that the system is updating the database. This will only take a few seconds to complete. Once finished, the user is prompted to physically disconnect the expansion shelf from the RNE. Refer to Figure 746-4. Pull the cards out of the shelves and remove the fibers if necessary.



**Danger:** Do not look into the ends of optical fibers. Exposure to invisible LASER radiation may cause serious retinal damage or even blindness. Verify the optical source is disabled through the use of an optical power meter before handling optical fibers.

**Stop! You have completed this procedure.**

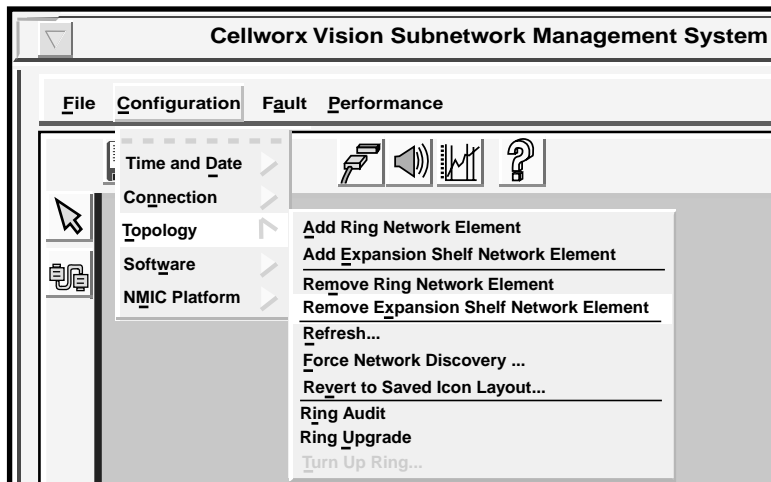

0026-047

Figure 746-1. Remove EPS NE Pull-down Menu

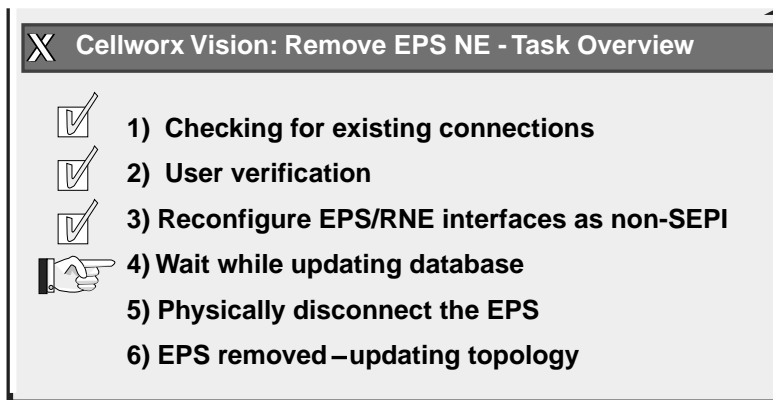

11919-B

Figure 746-2. Remove EPS NE Task Overview Window

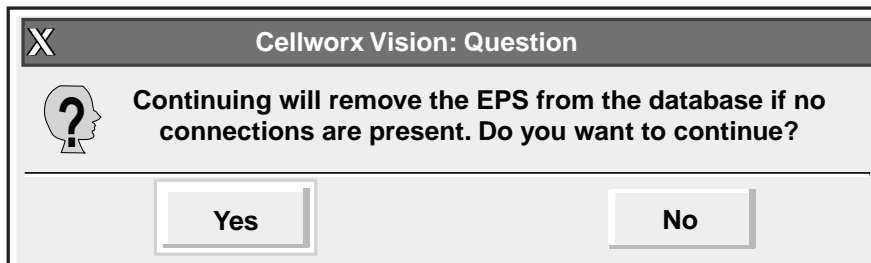

11914-B

Figure 746-3. Remove EPS Confirmation Window

**DLP-746**  
Page 3 of 3

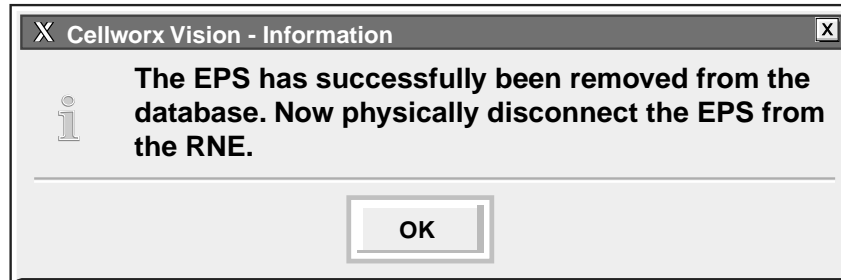

0026-048

Figure 746-4. Removed EPS Successfully Message Window



## SET E1 MULTI 1 CARD CONFIGURATION

**Summary:** This procedure details the steps required to set the E1 Multi 1 card configurations utilizing the Cellworx STN Phase 3.1 shelf level Graphical User Interface (GUI). User must have the GUI launched, and have accessed the shelf level GUI display per NTP-006 prior to performing this procedure.

1. Double click on the E1 Multi 1 card displayed in the shelf level GUI “Chassis View” at the top of the window. The E1 Multi 1 card display appears as shown in Figure 747-1.
2. Click and drag the small block upward to expand the Configuration section of the window so all or most options are visible. The Administrative State of the card and port should be “Unlocked” if in service. If “Locked”, select the “**Unlocked**” option using the left mouse button to enable the card and/or port for service.
3. Select a Port on the simulated card by a single click using the left mouse button.
4. Set the Port Level configuration options per requirements. Refer to Table 747-1 for a list of options the user may select for this card type.
5. Hit the **Apply** button at the bottom of the window to back up the new configuration data to the shelf controller.
  - **Note:** Selecting **Chassis View** will return the user to the previous window without closing the E1 Multi 1 window. Selecting **Refresh** will update the current window display with all the selections last recorded by the Shelf Controller card. Selecting **Close** will close this window and return the user to the Chassis View window.
6. If configuring the port for Cell Relay Service, continue with step 7. If configuring the port for Circuit Emulation Service, go to step 13.

## B. ATM INTERFACE CONFIGURATION (CRS MODE)

7. Double click on one of the ports available (1 to 16). The ATM interface screen appears. Refer to the example shown in Figure 747-2.
8. Set the ATM configuration options as needed. Table 747-2 shows a list of options the user may select.
9. Select the **Close** button to return to the E1 card display.
10. Repeat steps 3 through 6 for each E1 Multi 1 port on the card.
11. Select the **Close** button to return to the Chassis View window.
12. Repeat steps 1 through 11 for each card in the shelf.

C. CES INTERFACE CONFIGURATION

13. Double click on one of the ports available (1 to 16). The CES interface screen appears. Refer to the example shown in Figure 747-2.
14. Set the CES configuration options as needed using Table 747-3 as a reference.
15. Select the *Apply* button and then the *Close* button to return to the E1 card display.
16. Repeat steps 3 through 6 for each E1 Multi 1 port on the card.
17. Select the *Close* button to return to the Chassis View window.
18. Repeat steps 1 through 17 for each card in the shelf.

**Stop! You have completed this procedure.**

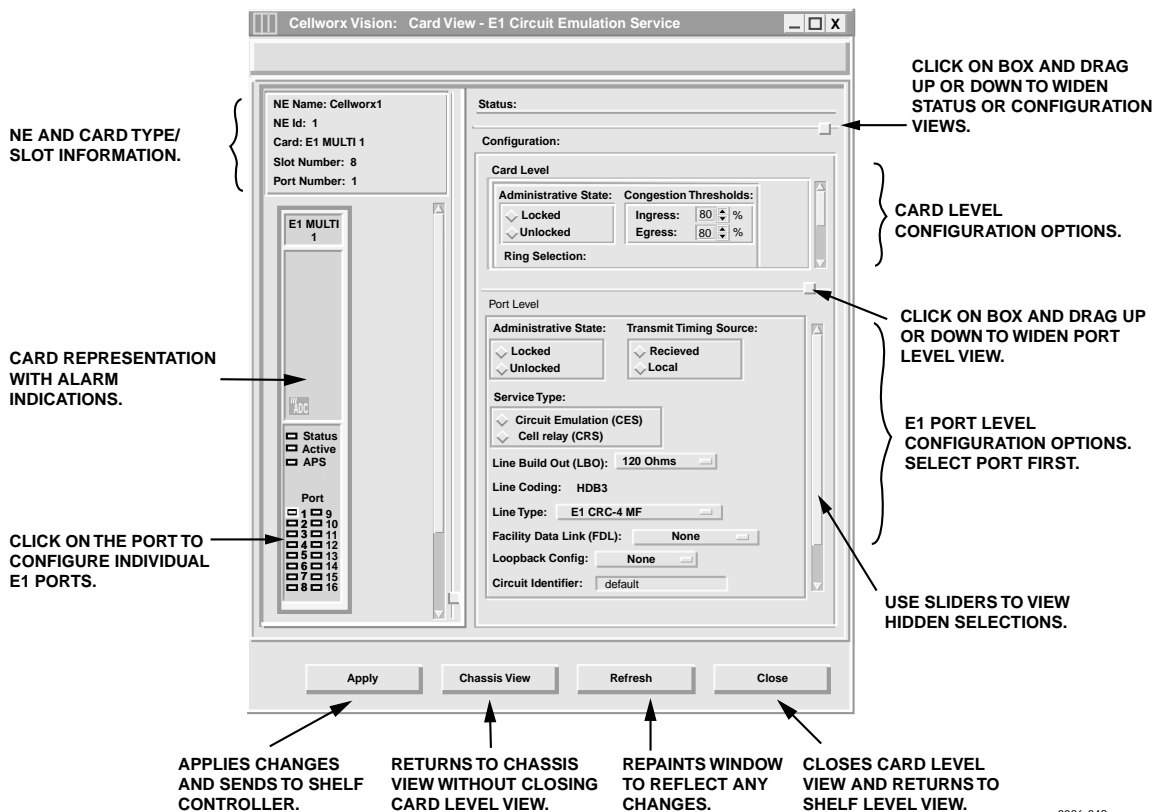

Figure 747-1. E1 Multi 1 Card Configuration Window

Table 747-1. E1 Multi 1 Configuration Options

SELECTION	DEFAULT	OPTIONS	DEFINITIONS
Card and Port Administrative State	Unlocked	Unlocked Locked	Enables or disables card or port for service, respectively.
Ingress/Egress Congestion Threshold	80	0-100	Percentage of ingress or egress buffer capacity that will cause a congestion threshold notification.
Ring Selection	Auto	Auto Ring 16 Ring 17	Card will automatically select traffic from the ring direction with the best signal. Card will receive traffic from Ring 16 direction. Card will receive traffic from Ring 17 direction.
Transmit Timing Source	Local	Received Local	Incoming clock pulse used for outgoing signal. Clock pulse supplied by the SC cards used for outgoing signal.
Service Type	CRS	CES CRS	Circuit Emulation Service. Cell Relay Service.
Line Build Out	120 Ohms	75 Ohms 120 Ohms	Sets the signal strength according to the distance in feet that the Cellworx STN is from the E1 interfacing equipment.
Line Coding	HDB3	HDB3	European Standard, non configurable.
Line Type	E1 CRC-4 MF	E1 CRC-4 MF	Sets the line type to reflect customer equipment. Must be set in groups of 8 ports (1-8 and 9-16).
Loopback. Config	None	None Terminal Facility Line	No loopback activated on this card. Sends cells to the cellbus and back to the ring. No changes are made to the path layer data. Loops the incoming signal back to CPE, generates AIS to the cellbus.
Circuit Identifier	<blank>	Up to 20 alphanumeric characters.	User defined. Usually describes the traffic, customer, and/or channel number.
Interface Name	<default>	Alphanumeric	User defined, up to 20 alpha numeric characters
Loopback Location Code	All 1s	Alphanumeric	Used to loopback the incoming signal and transmit it back to the customer equipment, limited to 16 numeric characters.
Recording Interface ID	All 0s	Numeric	Identifies the site card and port location for customer billing capabilities, (allows assignment of a customer ID for each port), limited to 15 numeric characters.
Provisioned Endpoints	0	User cannot configure.	Displays how many VPC or VCC endpoints are configured by administrator on this card.
Interface Type	UNI	UNI NNI	Specifies interface type as User to Network Interface or Network to Network Interface.
CAC Formula	PCR	PCR SCR	Specifies Peak Cell Rate or Sustained Cell Rate for Connection Admission Control.

(continued)

**DLP-747**

Page 4 of 5

**Table 747-2. ATM Interface Configuration Options for CRS Mode**

SELECTION	DEFAULT	OPTIONS	DEFINITIONS
Policing	Off	On or Off	User sets whether traffic will be policed for Quality Of Service (QOS).
Cell Scrambling	On	On or Off	User sets whether traffic will be scrambled.
Over Subscription Rate	100	100-1000	User sets percentage depending on traffic contract.
Max Active VPI Bits	0	0-8	Sets the maximum number of bits allowed may be utilized from this port.
Max Active VCI Bits	10	0 to 10	Sets the maximum number of bits allowed may be utilized from this port.
Max number of VPCs	1	0 to 256	Sets the maximum number of VPCs that may be utilized from this port.
Max number of VCCs	0	0 to 256	Sets the maximum number of VCCs that may be utilized from this port.

**Table 747-3. E1 Multi 1 Configuration Options for CES Mode**

SELECTION	DEFAULT	OPTIONS	DEFINITIONS
Interface Name	<default>	Alphanumeric	User defined, up to 20 alpha numeric characters.
ATM VPI	<user defined>	0-8	This is a read only to show the available bits configured for this port during connection creation.
ATM VCI	<user defined>	0-10	This is a read only to show the available bits configured for this port during connection creation.
Operational State	Up	Up/Down	This is a read only to show the state of the port.
Buffer Maximum Size	6220	5300 to 6220	Maximum size measured in microseconds and selectable in 10 microsecond increments.
Cell Arrival Jitter Tolerance	1040	950 to 2650	Maximum size measured in microseconds and selectable in 10 microsecond increments.
CBR Clock Mode	Adaptive	Adaptive, Synchronous, or SRTS	Sets the Constant Bit Rate clock to either adapt to the incoming bit stream or look for a constant synchronous bit stream.

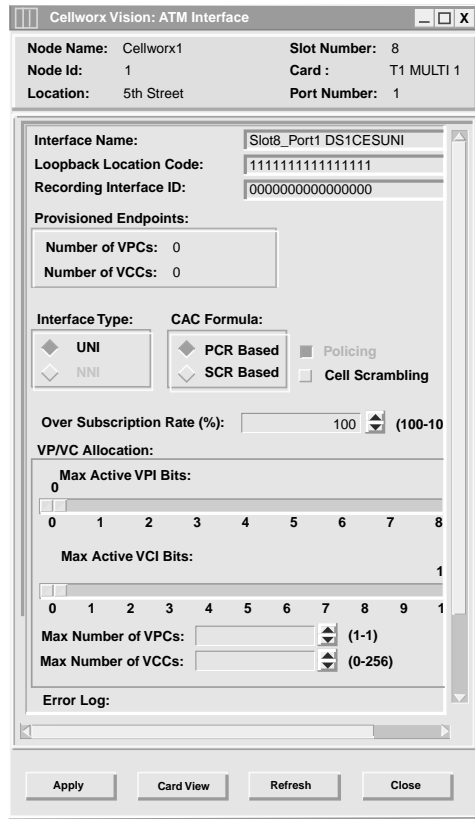

13431-A

Figure 747-2. E1 Multi 1 ATM Interface Options

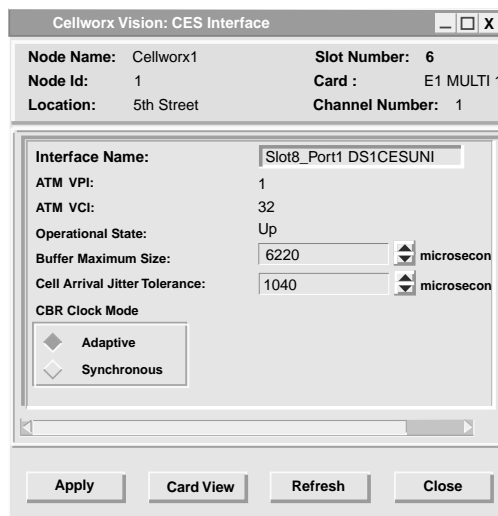

14547-A

Figure 747-3. CES Interface Menu Options

**DLP-748**

Page 1 of 3

**SET SC CARD CONFIGURATION**

**Summary:** This procedure details the steps required to set the SC card configurations utilizing the Cellworx STN Phase 3.1 shelf level Graphical User Interface (GUI). User must have GUI launched and accessed the chassis level GUI display per NTP-017 prior to performing this procedure.

1. Double click on the SC card located in slot 1 in the shelf level GUI “Chassis View” at the top of the window. Refer to Figure 748-1.
2. The SC card level display appears as shown in Figure 748-2. The Operational State of the card should be “Up”, Availability shown as “Available”, and Protection state may be “Enabled” or “Not Protected.” Use the small blocks on the configuration window to stretch the view upward, enabling all parameters to be displayed.
3. The SC card IP address enables remote Telnet sessions via 10Base-T connection on the slot 18 EIM to the Shelf Controller. Set the IP address per work order or customer specifications using dots between the sequences for the number values as shown in the following example:

ex., AAA.BBB.CCC.DDD

Where the - AAA = 0-255

BBB = 0-255

CCC = 0-255

DDD = 0-255

- ◆ **Note:** This IP address will always connect the user to the active SC.
4. The craft port bit rate is not configurable and is shown here for display only. Step through the remaining options and configure per system requirements. Refer to Table 748-1 for a list of available parameters for each option.
  5. Select the **Apply** button at the bottom of the window to send new parameters to the database.
  6. Select the **Close** button at the bottom of the window to return to the Chassis View.

**Stop! You have completed this procedure.**

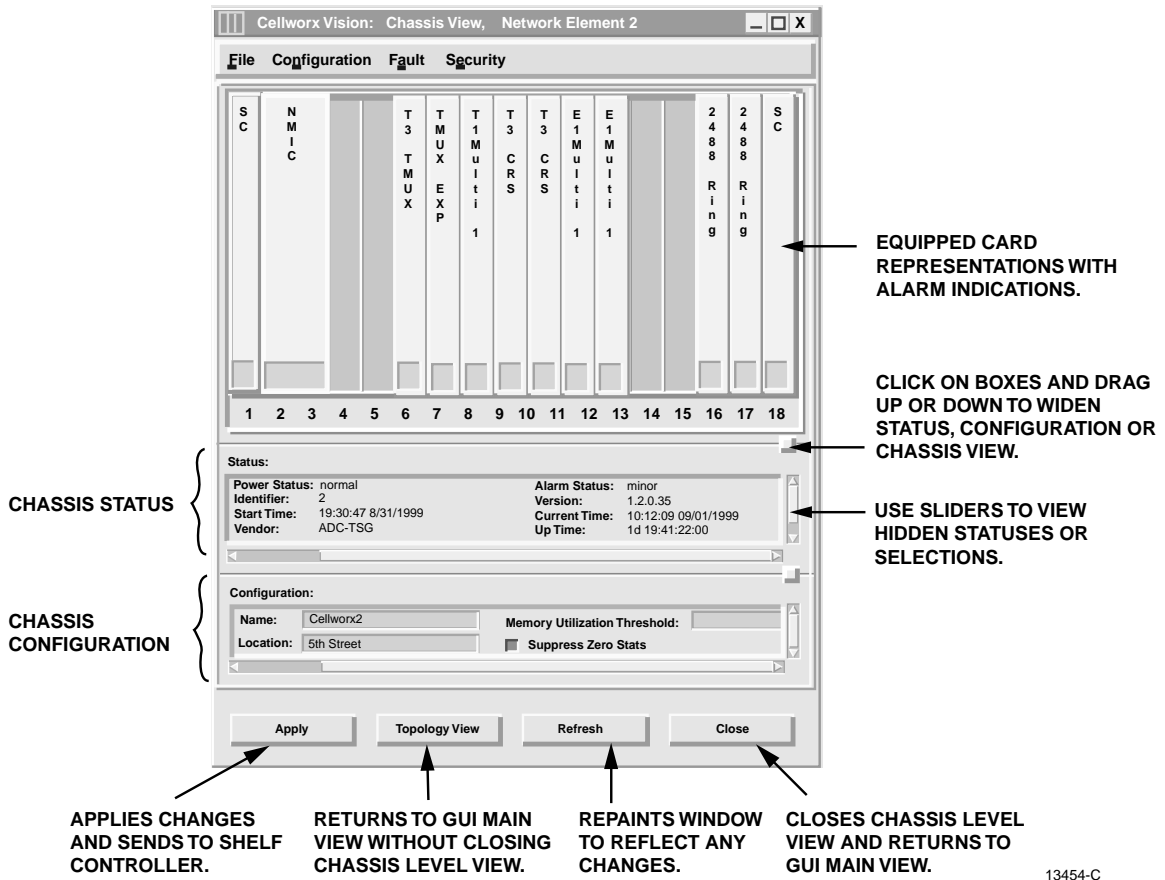

Figure 748-1. Shelf Level GUI Chassis View Window

DLP 748  
Page 3 of 3

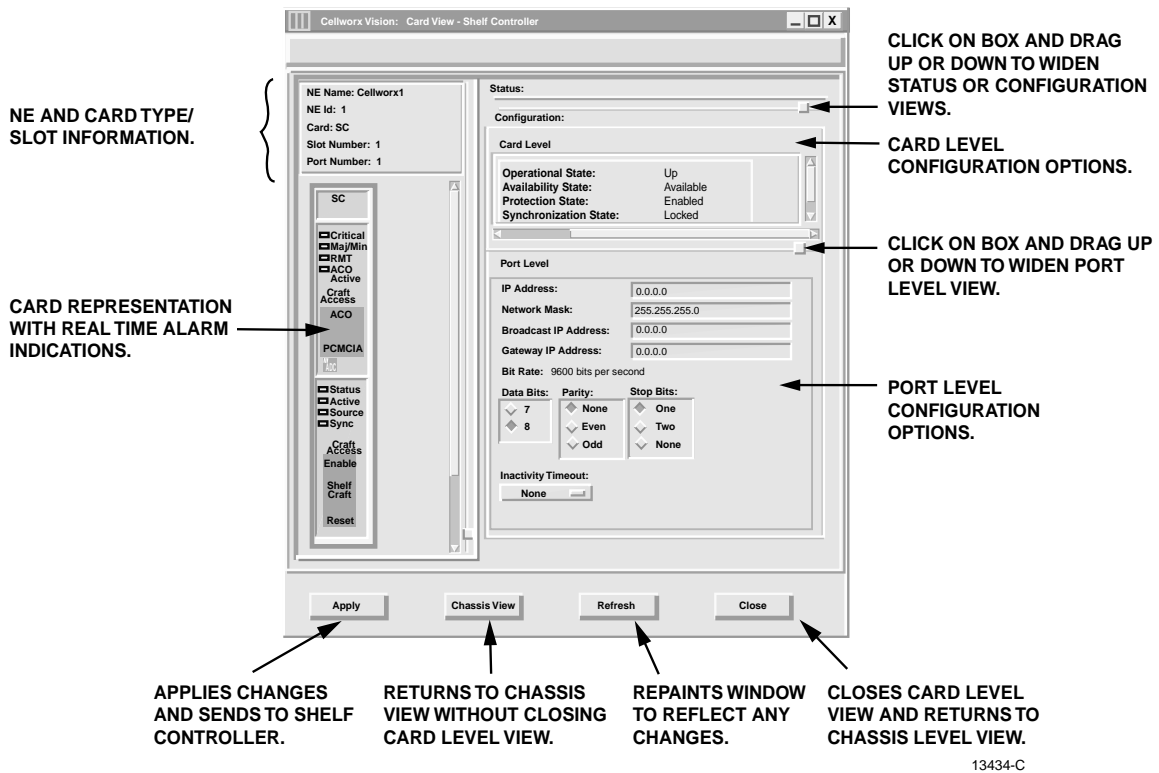

Figure 748-2. GUI SC Card Configuration Window

Table 748-1. Cellworx Serial Port Configuration Options

SELECTION	PORT	DEFAULT	OPTIONS	COMMENTS
Bit Rate	Craft	9600	No Options	Baud rate not currently selectable
Parity	Both	None	None, Even, Odd	Set per system requirements.
Data bit	Both	8	8, 7	Set per system requirements.
Stop bit	Both	1	None, 1, 2	Set per system requirements.
Inactivity Time-out	Both	None	None, 3 minutes, 5 minutes, 10 minutes, 15 minutes, 30 minutes, 1 hour, 2 hour, 6 hours, 12 hours, 1 day	Set per system requirements.



## SET SHELF TIMING RESOURCE

**Summary:** This procedure details the steps required to select Primary and Secondary timing input and output sources for clocking purposes. This also includes setting the protection modes for timing selections.

1. From the shelf level GUI Chassis View window, select the **Configuration** pull down menu using the mouse to click on it, or by entering “**Alt+N**” on the keyboard. Refer to Figure 749-1.
2. Select the **Timing Resources** option using the down arrow keys to highlight it and hitting “**Enter**” or “**Return**”, or by entering an “**Alt+T**” on the keyboard.
3. The Timing Resources shelf level GUI display appears as shown in Figure 749-2. Select the **Timing Reference** inputs, **DS1 Output Sources**, **Encoding Rules**, and **Frame Format** for both the Primary and Secondary circuits by clicking on the available selection using the left mouse button. Refer to Table 749-1 for a description of the selections available.
4. Select the Timing Protection Mode as either **Revertive** or **Non-Revertive** using the left mouse button, and enter a revertive time in minutes using the up/down arrow next to the **Revert Time** block
5. Select the **Apply** button at the bottom of the window to send the new configuration data to the database.
6. Select the **Close** button at the bottom of the window to return to the shelf level GUI Chassis View screen.

**Stop! You have completed this procedure.**

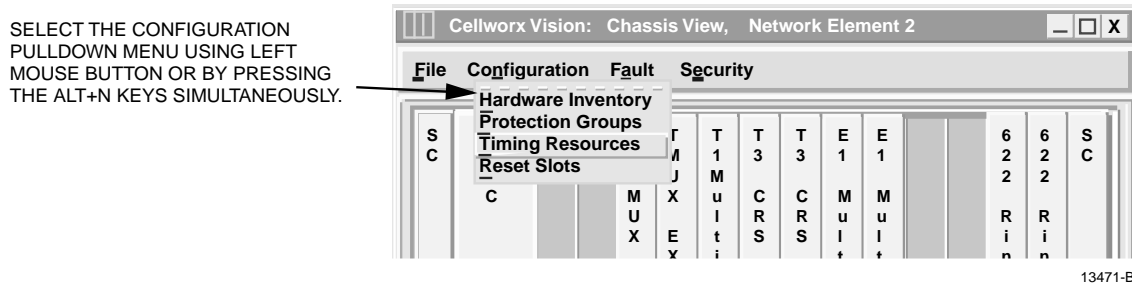

Figure 749-1. Shelf Level GUI Configuration Pull Down Menu

DLP-749  
Page 2 of 3

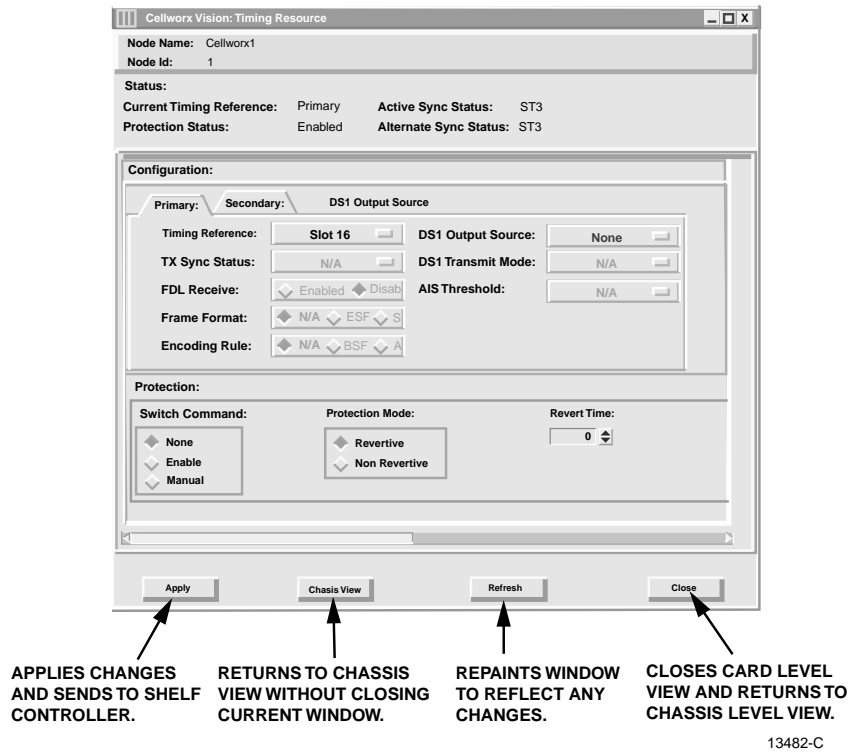

Figure 749-2. Shelf Level GUI Timing Resource Configuration Window

Table 749-1. Timing Resource Configuration Options

SELECTION (PRIMARY OR SECONDARY)	DEFAULT	OPTIONS	DEFINITIONS
Timing Reference	Internal	BITS Primary BITS Secondary Internal Slot XX	Hardwired in at SC EIM at CO. Hardwired in at SC EIM at CO. Uses internal Stratum 3 source. Uses any optical interface, DS3 running in PLCP mode, or an E1 card (XX=slot#).
DS1 Output Source	None	Slot XX None	Derives a T1 from a received optical signal of slot specified (XX=slot#). No source selected for output.
TX Sync Status	N/A	PRS ST2 ST3 SMC DUS	Primary Reference Source Stratum 2 level source Stratum 3 level source SONET Minimum level Clock Reference should not be used for source.

(continued)

Table 749-1. Timing Resource Configuration Options, continued

SELECTION (PRIMARY OR SECONDARY)	DEFAULT	OPTIONS	DEFINITIONS
DS1 Transmit Mode	AIS Threshold Generation	AIS Threshold Generation  Message Pass Through	Only available when Frame Format is set to ESF. Requires transmitting AIS over the derived DS1 signals if a clock reference has degraded below the threshold quality level.
FDL Receive	Enabled	Enabled Disabled	A peer-to-peer protocol across a T1 line providing OA&M functions (performance monitoring, loop back etc.) implemented via the framing bits in the T1 frame.
AIS Threshold	N/A	PRS ST1 ST2 ST3 SMC DUS	Primary Reference Source Stratum 1 level source Stratum 2 level source Stratum 3 level source SONET Minimum level Clock Reference should not be used for source.
Frame Format	ESF	ESF SF N/A	Extended Superframe Superframe Not Applicable when a DS1 Output is not selected.
Encoding Rule	B8ZS	B8ZS AMI N/A	Bit 8 Zero Substitution Alternate Mark Inversion Not Applicable when DS1 Output not selected.
PROTECTION			
Switch Command	None	None Enable  Manual	No switch command selected. Enables a switch to take place when needed, used after a manual switch to release the manual condition.. Initiates a switch to stand-by clock source.
Protection Mode	Non Revertive	Revertive  Non Revertive	Switches back to recovered primary source following a failure. Does not automatically revert back to primary source after a failure recovers.
Revertive Time (if Revertive)	0	0 to 1800 seconds N/A	Selectable up to 30 minutes. Not Applicable if non-revertive.

## DLP-750

Page 1 of 2

## SET SHELF HOUSEKEEPING ALARM CONFIGURATION

**Summary:** This procedure details the steps required to configure the housekeeping alarm messages that will be displayed when an input is triggered via an external source.

1. From the shelf level GUI Chassis View window, select the **Fault** pull down menu using the mouse to click on it, or by entering “**Alt+A**” on the keyboard. Refer to Figure 750-1.
2. Select the **Configure Housekeeping Alarms** option using the down arrow keys to highlight it and hitting “**Enter**” or “**Return**”, or by entering an “**Alt+A**” on the keyboard.
3. The Housekeeping Alarms shelf level GUI display appears as shown in Figure 750-2. The State column indicates the current state of that alarm input. A green square indicates no alarm is present, while the Red square indicates an alarm condition is active on that input.
4. Enter in an alarm description for each of the eight alarm interfaces according to the type of equipment hardwired to the SC EIM card. Refer to the label located inside the front door panel if necessary. This label should have been filled out by the installer during installation. Refer to List of related Publications in the preface of this manual for installation procedures.
5. Select the **Apply** button at the bottom of the window to send the new configuration data to the database.
6. Select the **Close** button at the bottom of the window to return to the shelf level GUI Chassis View screen.

**Stop! You have completed this procedure.**

SELECT THE FAULT PULLDOWN MENU USING LEFT MOUSE BUTTON OR BY PRESSING THE ALT+A KEYS SIMULTANEOUSLY.

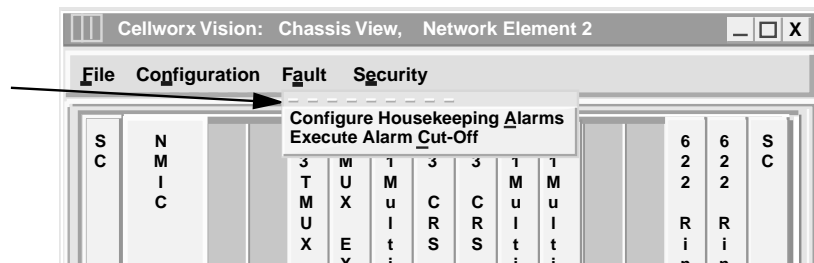

13473-C

Figure 750-1. Shelf Level GUI Fault Pull Down Menu

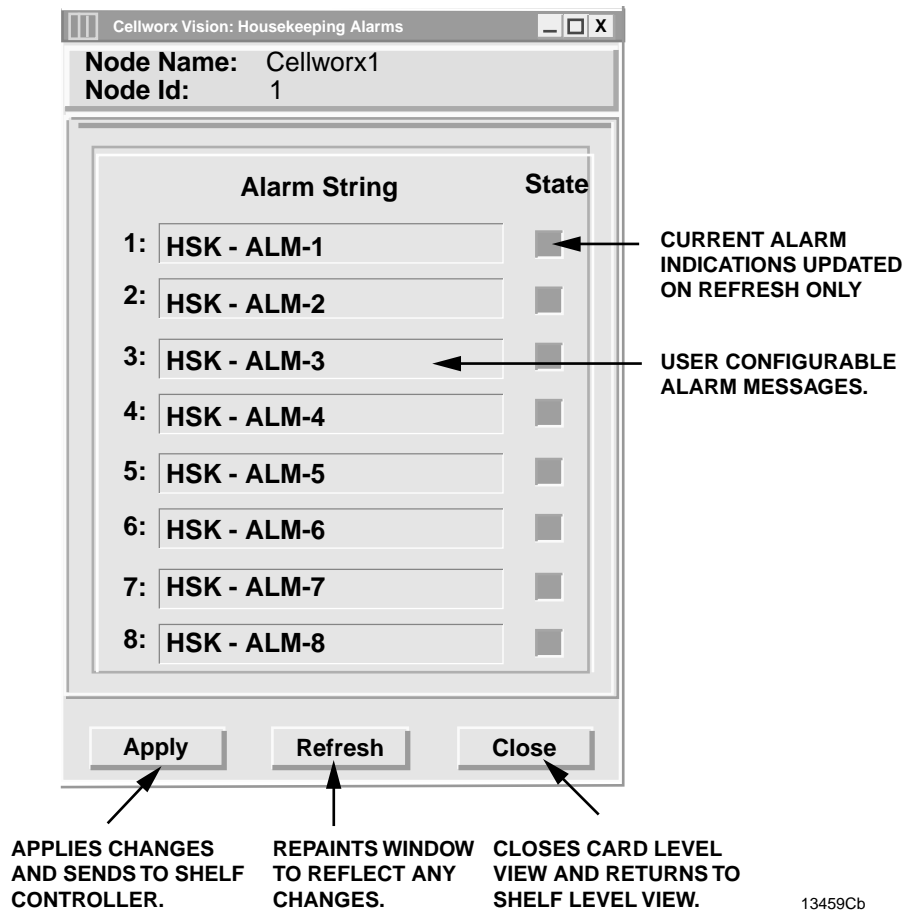

Figure 750-2. Housekeeping Alarm Input Configuration Window

## DLP-751

Page 1 of 3

### SET 622 RING INTERFACE CARD (RIC) CONFIGURATION

**Summary:** This procedure details the steps required to set the 622 Ring interface card configurations utilizing the Cellworx STN Phase 3.1 shelf level Graphical User Interface (GUI). User must have the GUI launched and accessed the shelf level GUI display per NTP-006 prior to performing this procedure.

1. Double click on the 622 RIC located in slot 16 or 17 in the shelf level GUI “Chassis View” at the top of the window.
2. The 622 RIC display appears as shown in Figure 751-1. The Administrative State of the card and port should be “Unlocked” if in service and cannot be set using the GUI. If two RICs were set to “Locked”, the node could be isolated requiring a complete ring turn up.
3. Set the rest of the configuration options for the card and port using Table 751-1 for descriptions of the options.
4. Select the **Apply** button at the bottom of the window to send the new configuration data to the shelf controller.
  - ◆ **Note:** Selecting **Chassis View** will return the user to the previous window without closing the 622 RIC window. Selecting **Refresh** will update the current window display and all the selections last recorded by the Shelf Controller card. Selecting **Close** will close this window.
5. Repeat steps 1 through 5 the second 622 RIC card installed in the shelf.

**Stop! You have completed this procedure.**

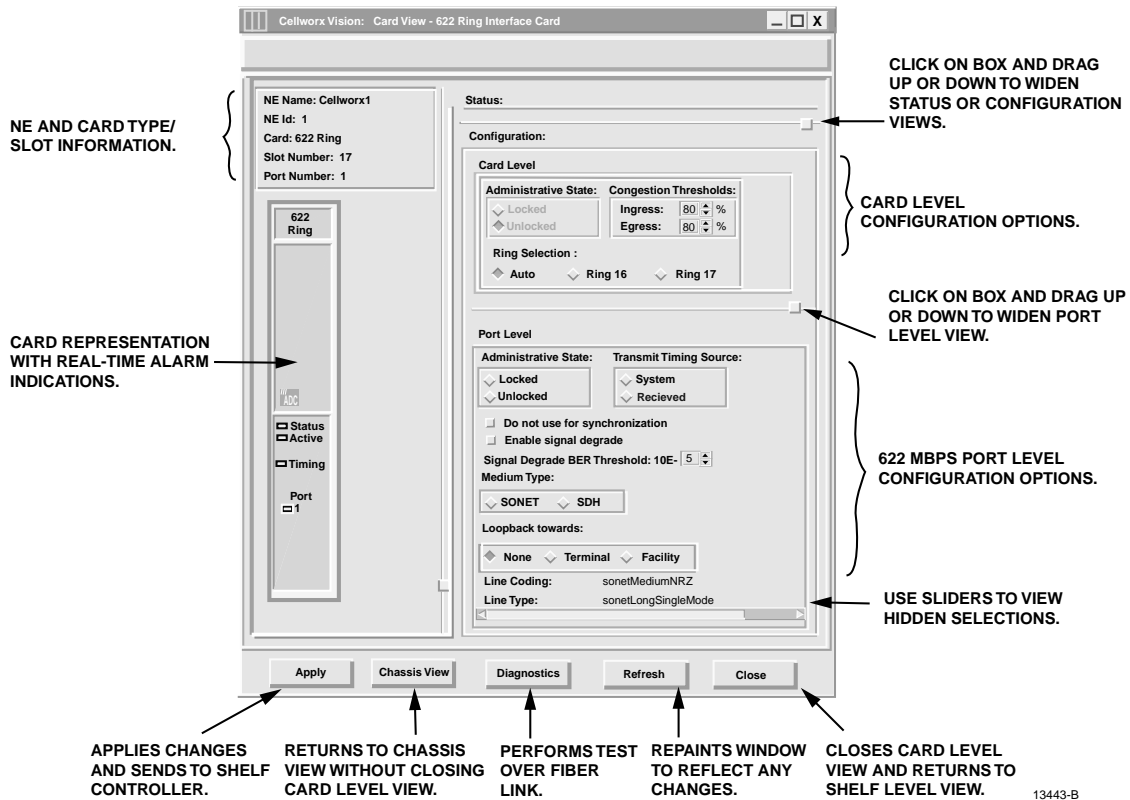

Figure 751-1. 622 RIC Shelf Level GUI Configuration Screen

Table 751-1. 622 RIC Card Configuration Options

SELECTION	DEFAULT	OPTIONS	DEFINITION
Admin State	Unlock	N/A	Not Configurable on RIC
Congestion Threshold	80	0-100	Percentage of buffer capacity that will cause a congestion threshold notification for Ingress and Egress.
Ring Selection	Auto	N/A	Not Configurable on RIC
Transmit Timing Source	System	System Received	Uses Primary timing reference. Uses clock derived from incoming receive fiber (also known as Line-Timing).
Do Not Use for Sync	False	Selected (true) Not selected (false)	If "True", causes the RIC to output DUS (Do not Use for Sync) in the S1 byte of the SONET overhead.
Enable Signal Degradate	Not Selected	Selected Not Selected	Enables a protection switch of the traffic if the input signal strength drops below tolerable levels set by the user in the BER threshold selection.

(continued)

## DLP-751

Page 3 of 3

Table 751-1. 622 RIC Card Configuration Options, continued

SELECTION	DEFAULT	OPTIONS	DEFINITION
Signal Degrade BER Threshold	5	5 through 9	Defines the number of bit errors the port can incur before a signal degrade occurs and generates an alarm message and probably protection switch.
Medium Type	SONET	SONET SDH	Not configurable on RIC. This is determined by the dipswitch on the SC EIM, which sets the shelf type. Can be SONET, Synchronous Optical Network, US, or Synchronous Digital Hierarchy, European standard for transporting data over fiber.
Loopback towards	None	None Terminal Facility	No loopback activated on this card. Sends cells back to the cellbus and back out to the ring. No changes are made to the path layer data. Loops the incoming signal back to the CPE and generates AIS to the cellbus.
Line Coding	NRZ		Not configurable by user.
Line Type	Card Dependant	SonetOther sonetShortSingle Mode sonetLongSingle Mode sonetMultiMode	Not configurable by user, dependant on card type inserted.
Transmit Path Trace	(example) NE1_Slot17_ Port1 (OC12)		Card position dependent. This is assigned by the system according to the NE and slot it is equipped in.

1



## SET 155 SM/MM CRS CARD CONFIGURATION

**Summary:** This procedure details the steps required to set the 155 SM/MM CRS card configurations utilizing the Cellworx STN Phase 3.1 shelf level Graphical User Interface (GUI). Configuration can be set for the card, port and ATM interface on individual ports. This procedure is divided into two sections with the second section dealing with the ATM interface screens. The user must have the GUI launched and accessed the shelf level GUI display per NTP-006 prior to performing this procedure.

### A. CARD AND PORT CONFIGURATION

1. Double click on the 155 SM/MM CRS card displayed in the shelf level GUI “Chassis View” at the top of the window.
2. The 155 SM/MM CRS card display appears as shown in Figure 752-1. Click on the port to be configured (Port 1 or 2) located on the simulated card on the left side of the window.
3. Click and drag the small block upward to expand the Configuration section of the window so all options are visible. The Administrative State of the card and port should be “Unlocked” if in service. If “Locked”, select the “**Unlocked**” option using the left mouse button to enable the port for service.
4. At Timing Port, select the port that will be used as a reference if this slot is selected as a timing source from the Timing Resource Screen.
5. If this card and port are being utilized as an expansion shelf interface (either from ring to EPS, or EPS to ring), select the Expansion Shelf Interface button.
6. Set the Port Level configuration options per requirements. Refer to Table 752-1 for a list of options the user may select for this card type.
7. Hit the **Apply** button at the bottom of the window to back up the new configuration data to the shelf controller.

► **Note:** Selecting **Chassis View** will return the user to the previous window without closing the 155 SM/MM CRS window. Selecting **Refresh** will update the current window display and all the selections last recorded by the Shelf Controller card. Selecting **Close** will close this window.

### B. ATM INTERFACE CONFIGURATION

8. Double click on either of the ports available (1 or 2). The ATM interface screen appears. Refer to the example shown in Figure 752-2.
9. Set the ATM options as needed using Table 752-2 as a reference.

DLP-752  
Page 2 of 4

10. Repeat steps 1 through 9 for each 155 SM/MM CRS card installed in the shelf.

**Stop! You have completed this procedure.**

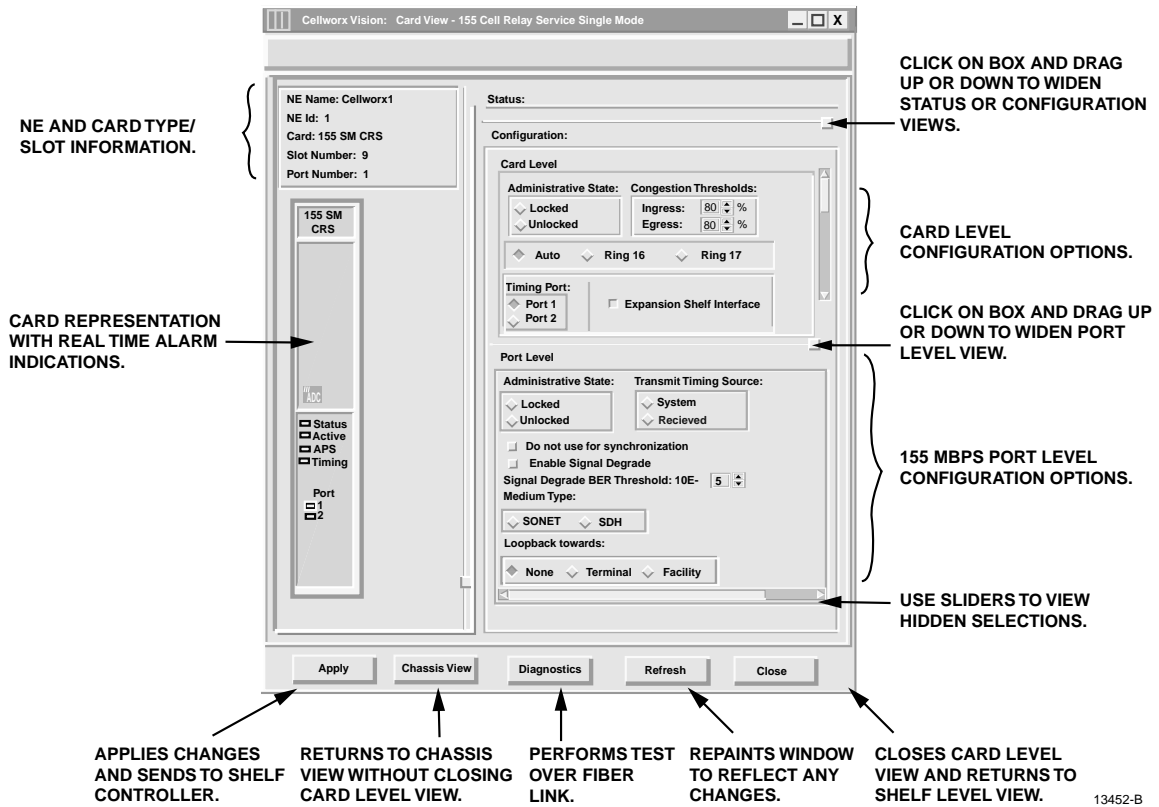

Figure 752-1. 155 SM CRS Card Shelf Level GUI Configuration Screen

Table 752-1. 155 SM/MM CRS Card Configuration Options

SELECTION	DEFAULT	OPTIONS	DEFINITIONS
Admin State	Unlock	Lock / Unlock	Enable or disable card / port for service.
Congestion Threshold	80	0-100	Percentage of ingress buffer capacity that will cause a congestion threshold notification.
Ring Selection	Auto	Auto Ring 16 Ring 17	Card will automatically select traffic from the ring direction with the best signal. Card will receive traffic from Ring 16 direction. Card will receive traffic from Ring 17 direction.
Timing Port Selection	1	1 or 2	Selects the port to use as a reference when this slot is selected as the shelf timing source.
Shelf Expansion Interface	Selected	Selected Not selected	Determines if the 155 SM/MM CRS card is being used as an expansion shelf interface (SEPIC) in an EPS or RNE. Click on the box to select it.

(continued)

Table 752-1. 155 SM/MM CRS Card Configuration Options, continued

SELECTION	DEFAULT	OPTIONS	DEFINITIONS
Transmit Timing Source	System	System Received	Uses Primary timing reference. Uses clock derived from incoming receive fiber (also known as Line-Timing).
Do Not Use for Sync	False	Selected (True) Non-selected (False)	Outputs DUS (Do not Use for Sync) in the S1 byte of the SONET overhead.
Enable Signal Degrade	Not Selected	Selected Not Selected	Enables a protection switch of the traffic if the input signal strength drops below tolerable levels set by the user in the BER threshold selection.
Signal Degrade BER Threshold	5	5 through 9	Defines the number of bit errors the port can incur before a signal degrade occurs and generates an alarm message and probably protection switch.
Medium Type	SONET	SONET SDH	Synchronous Optical Network, US standard for transporting data over fiber. Synchronous Digital Hierarchy, European standard for transporting data over fiber.
Loopback Towards	None	None Terminal Facility	No loopback is requested or active. A loopback has been activated sending the signal back to the terminal side. A loopback has been activated sending the signal back to the facility side.
Line Coding	NRZ		Not configurable by user.
Line Type	Card Dependant	SonetOther sonetShortSingleMode sonetLongSingleMode sonetMultiMode	Not configurable by user, dependant on card type inserted.
Transmit Path Trace	User defined		User can define a unique ID to this port for identification purposes on SM cards only.

Table 752-2. ATM Interface Configuration Options

SELECTION	DEFAULT	OPTIONS	DEFINITIONS
Interface Name	<default>	Alphanumeric	User defined, up to 20 alphanumeric characters.
Loopback Location Code	All 1s	Alphanumeric	Used to loopback the incoming signal and transmit it back to the customer equipment. The code is limited to 16 numeric characters.

(continued)

Table 752-2. ATM Interface Configuration Options, continued

SELECTION	DEFAULT	OPTIONS	DEFINITIONS
Recording Interface ID	All 0s	Numeric	Identifies the site card and port location for customer billing capabilities, (allows assignment of a customer ID for each port.) The code is limited to 15 numeric characters.
UNI/ NNI Select	UNI	UNI NNI	Specifies interface type as User to Network Interface or Network to Network Interface.
CAC Formula	PCR	PCR SCR	Specifies Peak Cell Rate or Sustained Cell Rate for Connection Admission Control calculations.
Traffic Policing	Enable	Enable Disable	User sets whether traffic will be policed for Quality Of Service (QOS).
Cell Scrambling	True	True or False	User sets whether traffic will be scrambled.
Subscription Rate	100	PCR: 100 to 1000 SCR: 1 to 100	User sets depending on traffic contract.
Max Active VPI/VCI Bits	0	0 to 12	Sets maximum number of bits allowed to select virtual channel from.
Max number of VPCs	4096	0-4096	Sets maximum number of virtual path circuits that may be assigned on this port.
Max number of VCCs	0	0-8192	Sets maximum number of virtual channel circuits that may be assigned on this port.

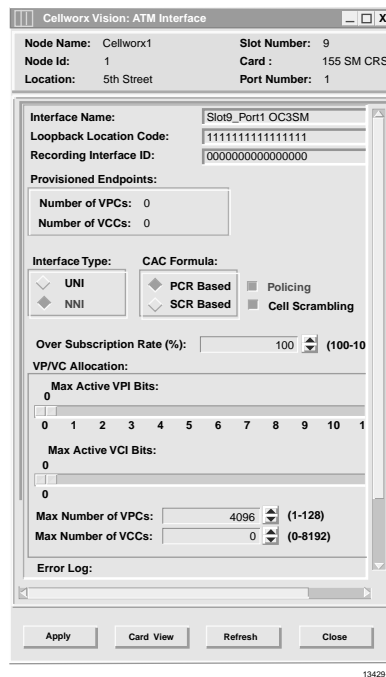

Figure 752-2. 155 SM/MM CRS ATM Port Interface Configuration Screen

## SET T3 CRS CARD CONFIGURATION

**Summary:** This procedure details the steps required to set the T3 CRS card configurations utilizing the Cellworx STN Phase 3.1 shelf level Graphical User Interface (GUI). User must have the GUI launched and accessed the shelf level GUI display per NTP-006 prior to performing this procedure.

1. Double click on the T3 CRS card displayed in the shelf level GUI “Chassis View” at the top of the window.
2. The T3 CRS card display appears as shown in Figure 753-1. Click on the port to be configured (Port 1, 2, or 3) located on the simulated card on the left side of the window.
3. Click and drag the small block upward to expand the Configuration section of the window so all options are visible. The Administrative State of the card and port should be “Unlocked” if in service. If “Locked”, select the “*Unlocked*” option using the left mouse button to enable the card and/or port for service.
4. If this card and port are being utilized as an expansion shelf interface (either from ring to EPS, or EPS to ring), select the Expansion Shelf Interface button.
5. At Timing Port, select the port that will be used as a reference when this slot is selected as a timing source from the Timing Resource Screen.
6. Set the Port Level configuration options per requirements. Refer to Table 753-1 for a list of options the user may select for this card type.
7. Hit the **Apply** button at the bottom of the window to back up the new configuration data to the shelf controller.

► **Note:** Selecting *Chassis View* will return the user to the previous window without closing the T3 CRS window. Selecting *Refresh* will update the current window display and all the selections last recorded by the Shelf Controller card. Selecting *Close* will close this window.

## B. ATM INTERFACE CONFIGURATION

8. Double click on one of the ports available (1, 2, or 3). The ATM interface screen appears. Refer to the example shown in Figure 753-2.
9. Set the ATM configuration options as needed using Table 753-2 as a reference.
10. Repeat steps 1 through 9 for each T3 CRS card/port installed in the shelf.

**Stop! You have completed this procedure.**

DLP-753  
Page 2 of 4

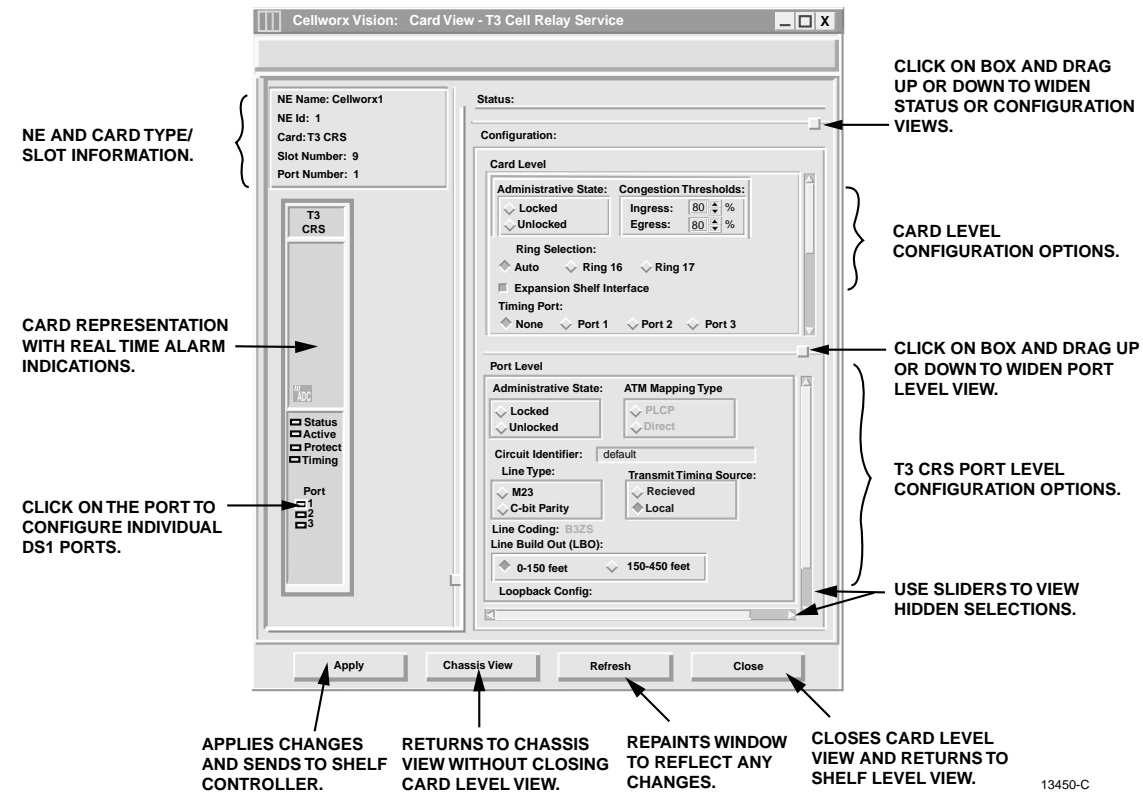

Figure 753-1. T3 CRS Configuration Screen

Table 753-1. T3 CRS Configuration Options

SELECTION	DEFAULT	OPTIONS	DEFINITIONS
Slot #	2	2 to 15 for Ring NE 2 to 15 for STN- EPS	Physical slot locations of the T3 cards in the shelf.
Admin State (Card or Port)	LOCKED	LOCKED/ UNLOCKED	Locked = Out of service. Unlocked = In service.
Congestion Threshold	0	0 to 100	Threshold for CLP=1 cells to be discarded on the ingress/egress path.
Ring Selection	Auto	Auto  Ring 16 Ring 17	Card will automatically select traffic from the ring direction with the best signal. Card will receive traffic from Ring 16 direction. Card will receive traffic from Ring 17 direction.
Expansion Shelf Interface	Not Selected	Selected Not Selected	Determines if the card is being used as an expansion shelf interface (SEPIC) in an EPS or RNE. Click on the box to select it.

(continued)

Table 753-1. T3 CRS Configuration Options, continued

SELECTION	DEFAULT	OPTIONS	DEFINITIONS
Timing Port	None	None Port 1 Port 2 Port 3	None does not provide timing when card slot is selected, or uses Port 1, 2, or 3 for timing source when slot is selected for system timing from Timing Resource screen.
Line Type	M23	M23  C-bit Parity	Asynchronous, M23 multiplex format, PM parameters based on P-Bit Parity Errors (PE).  Synchronous T3, M13 multiplex format, separate PM parameters based on P-Bit Parity Errors (PE) CRC violations.
ATM Mapping Types	Direct	Direct PLCP	HEC based "Direct" mapping. Physical Layer Convergence Protocol mapping.
Transmit Timing Source	Local	Received  Local	The Tx clock (and data rate) is the same frequency as the RX clock and data rate (receive clock is looped to the transmitter).  The on-board crystal oscillator is used for the clock source, so the transmit clock will be a nominal 44.736 Mhz and will not equal the receive clock frequency.
Line Build Out	Off	Off / On	Sets the signal level to compensate for the distance between the system and the interfacing equipment.
Loopback Config.	None	None Terminal  Facility  Payload	No loopback activated on this card. Sends cells back to the cellbus and back out to the ring. No changes are made to the path layer. Loops the incoming signal back to the CPE and generates AIS to the cellbus. Loops the signal back to the CPE AFTER framing is performed and before being converted to ATM cells.
Far End Loopback	None	Payload Reset Line	Determine the type of loop back at the far end to test continuity between the far end and near end.

Table 753-2. ATM Interface Configuration Options

SELECTION	DEFAULT	OPTIONS	DEFINITIONS
Interface Name		Alphanumeric	User defined, up to 20 alpha numeric characters.
Loopback Location Code	All 1s	Alphanumeric	Used to loopback the incoming signal and transmit it back to the customer equipment. The code is limited to 16 numeric characters.
Recording Interface ID	All 0s	Numeric	Identifies the site card and port location for customer billing capabilities, (allows assignment of a customer ID for each port.) The code is limited to 15 numeric characters.

(continued)

Table 753-2. ATM Interface Configuration Options, Continued

SELECTION	DEFAULT	OPTIONS	DEFINITIONS
Interface Type	UNI	UNI NNI	Specifies interface type as User to Network Interface or Network to Network Interface.
CAC Formula	PCR	PCR SCR	Specifies Peak Cell Rate or Sustained Cell Rate for Connection Admission Control calculations.
Policing	Off	On or Off	User sets whether traffic will be policed for Quality Of Service (QOS).
Cell Scrambling	Off	On or Off	User sets whether traffic will be scrambled.
Over Subscription Rate	100		User sets depending on traffic contract.
Max Active VPI/VCI Bits	0	0-12	Sets maximum number of bits allowed to select VCs from.
Max number of VPCs	1	1 to 2048	Sets the maximum number of VPCs that may be utilized from this port.
Max number of VCCs	0	0 to 8192	Sets the maximum number of VCCs that may be utilized from this port.

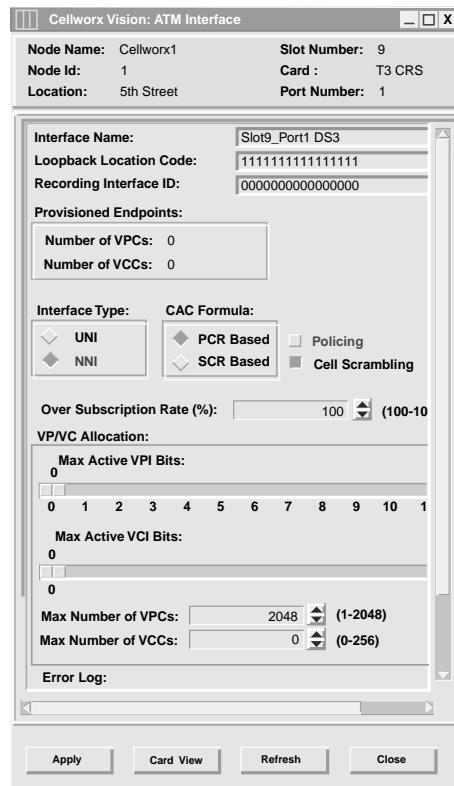

13432-A

Figure 753-2. T3 CRS ATM Interface Screen



## SET T3 TMUX MULTI 1 AND TMUX EXP CARD CONFIGURATION

**Summary:** This procedure details the steps required to set the T3 TMUX Multi 1 and TMUX EXP (expansion) card configurations utilizing the Cellworx STN Phase 3.1 shelf level Graphical User Interface (GUI). User must have the GUI launched, and have accessed the shelf level GUI display per NTP-006 prior to performing this procedure.

1. Double click on the T3 TMUX Multi 1 card displayed in the shelf level GUI “Chassis View” at the top of the window. If this card has a TMUX EXP associated with it, they will be treated as one card for configuration.
2. The T3 TMUX Multi 1 card display appears either as a single T3 TMUX Multi 1 or as shown in Figure 754-1 as a T3 TMUX Multi 1 and TMUX EXP pair.

► **Note:** When the T3 TMUX Multi 1 is accompanied by a TMUX EXP card, selecting either card will result in having both cards displayed since they are treated as a pair.

3. Click and drag the small block upward to expand the Configuration section of the window so all or most options are visible. The Administrative State of both cards and port should be “Unlocked” if in service. If “Locked”, select the “**Unlocked**” option using the left mouse button to enable either or both cards and/or port for service. To select the TMUX EXP card, click on the tab with the correct slot number on it. This will allow the user to toggle between the T3 TMUX MULTI 1 and TMUX EXP.
4. At the Circuit Identifier field, enter a unique ID for this circuit per work order or customer requirements.
5. Set the rest of the Port Level configuration options per requirements. Refer to Table 754-1 for a list of options the user may select for this card type.
6. Hit the **Apply** button at the bottom of the window to back up the new configuration data to the shelf controller.

► **Note:** Selecting **Chassis View** will return the user to the previous window without closing the T3 TMUX Multi 1 window. Selecting **Refresh** will update the current window display and all the selections last recorded by the Shelf Controller card. Selecting **Close** will close this window and return the user to the Chassis View window.

7. Click on the DS1 Channel tab shown on the simulated T3 TMUX Multi1 card view. This will bring up the DS1 Channel view as shown in Figure 754-2.
8. Select a DS1 channel that needs to be configured at the upper left block of the screen above the card view.
9. Again, the Administrative State of the channels should be “Unlocked” if in service. If “Locked”, select the “**Unlocked**” option using the left mouse button to enable the channel for service.

DLP-754

Page 2 of 7

10. Set the rest of the DS1 Channel Level configuration options per requirements. Refer to Table 754-2 for a list of options the user may select.
11. Select the **Apply** button after configuring the channel.
12. Double click on the DS3 port on the faceplate to bring up the Interface type screen. If CRS was selected, the screen shown in Figure 754-3 will appear. If CES service type was selected, the screen shown in Figure 754-4 will appear. Select the configuration for the Service type on the port using Table-754-3 as a reference for CRS mode or Table 754-4 for CES mode.
13. Select the **Apply** button followed by the **Close** button to return to the card view screen.
14. Repeat steps 8 through 14 for each channel on the T3 port.
15. Select the **Close** button on the DS1 Channel window and the T3 TMUX Multi 1 window using the left mouse button once all channels have been configured.
16. Repeat steps 1 through 16 for each T3 TMUX Multi 1 card installed in the shelf.

**Stop! You have completed this procedure.**

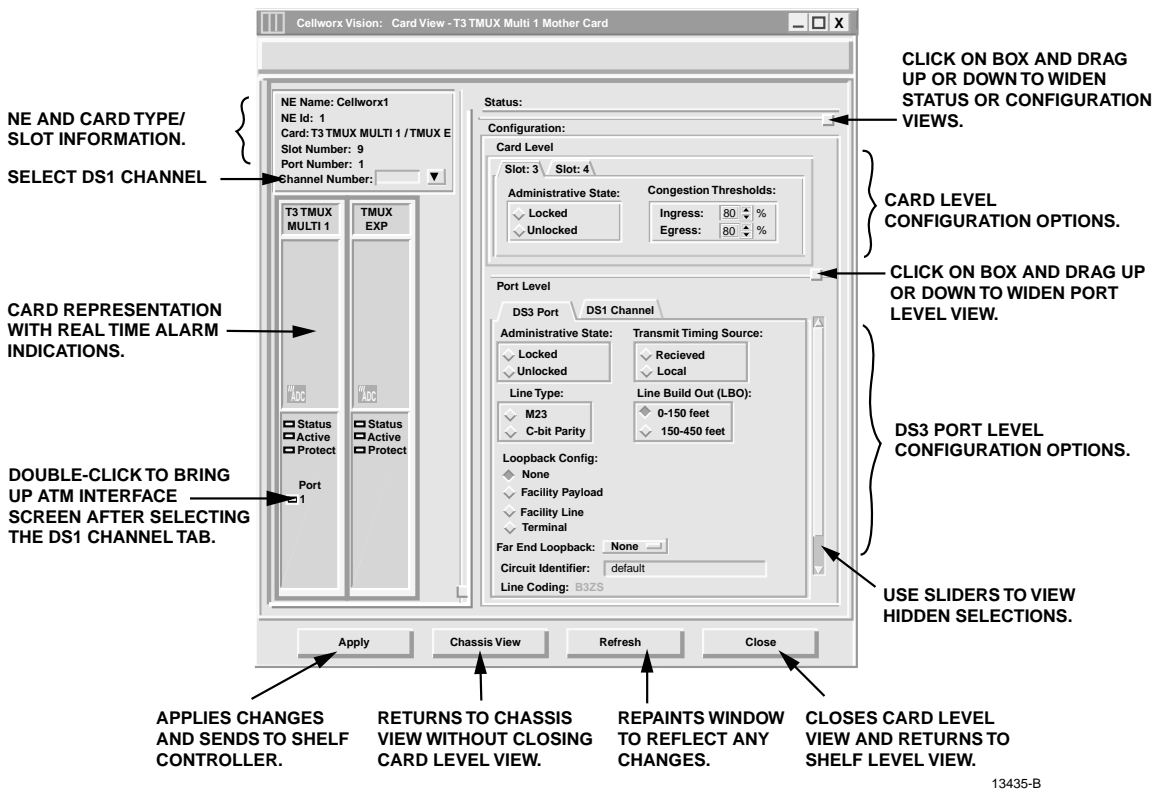

Figure 754-1. T3 TMUX Multi 1 Card Configuration Window

Table 754-1. T3 TMUX Multi 1 Card Configuration Options

SELECTION	DEFAULT	OPTIONS	DEFINITIONS
Card and Port Administrative State	Unlocked	Unlocked Locked	Enables or disables card for service, respectively.
Congestion Threshold	0	0 to 100	Threshold for CLP=1 cells to be discarded on the ingress/egress path.
Ring Selection	Auto	Auto Ring 16 Ring 17	Card will automatically select traffic from the ring direction with the best signal. Card will receive traffic from Ring 16 direction. Card will receive traffic from Ring 17 direction.
Transmit Timing Source	Local	Received  Local	The Tx clock (and data rate) is the same frequency as the RX clock and data rate, (receive clock is looped to the transmitter).  The on-board crystal oscillator is used for the clock source and will not equal the receive clock frequency.
Line Type (CRS ONLY)	M23  Cbit Parity.	M23  ANSI T1.107a-1989 Cbit Parity	Asynchronous, M23 multiplex format, PM parameters based on P-Bit Parity Errors (PE).  Synchronous T3, M13 multiplex format, separate PM parameters based on P-Bit Parity Errors (PE) CRC violations.
Loopback Config.	None	None Terminal  Facility  Payload	No loopback activated on this card.  Sends cells back to the cellbus and back out to the ring. No changes are made to the path layer data.  Loops the incoming signal back to the CPE and generates AIS to the cellbus.  Loops the signal back to the CPE AFTER framing is performed and before being converted to ATM cells.
Far End Loopback	None	None  Payload  Reset Line	No loopback has been requested for far end.  Requests a Payload loopback for far end. Resets a loopback at the far end. Requests a loopback for the line at the far end.
Circuit Identifier	<blank>	Any alphanumeric characters, up to 20.	User defined. Usually describes the traffic or customer, slot, and port.
Line Coding	B3ZS	<none>	This field is not configurable, display only.
Line Build Out	Off	Off / On	Sets the signal level to compensate for the distance between the system and the interfacing equipment.

DLP-754  
Page 4 of 7

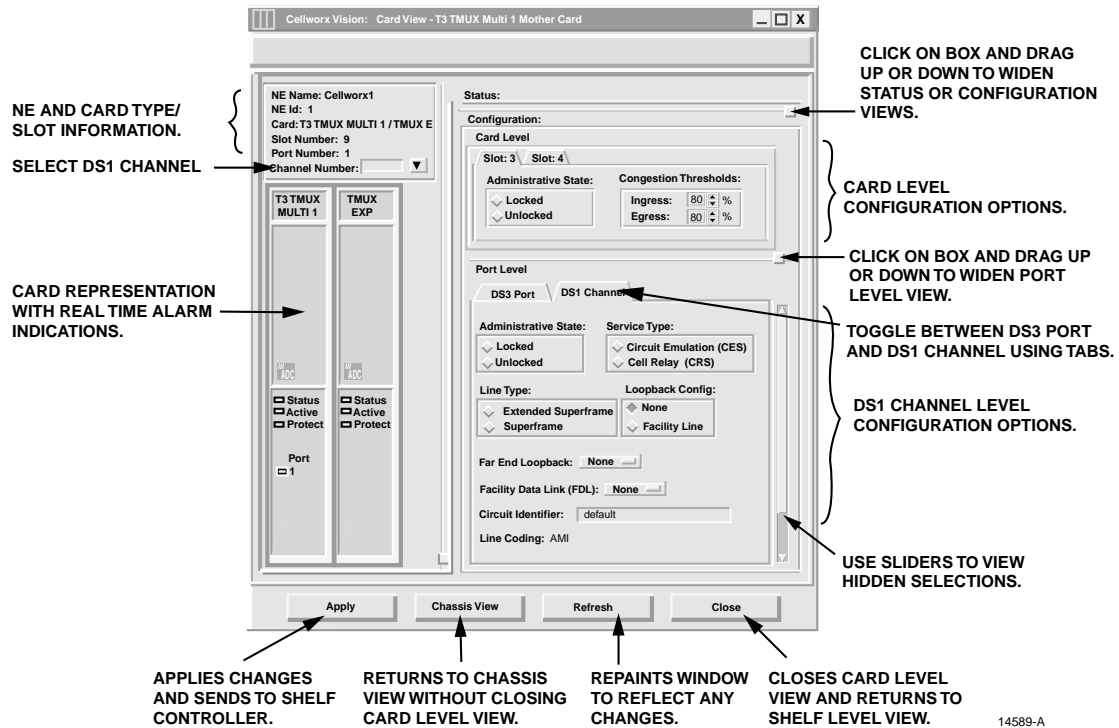

Figure 754-2. T3 TMUX Multi 1 T1 Level Configuration Screen

Table 754-2. T3 TMUX Multi 1 T1 Channel Configuration Options

SELECTION	DEFAULT	OPTIONS	DEFINITIONS
Administrative State	Unlocked	Unlocked Locked	Enables or disables channel for service, respectively.
Service Type	CRS	CES CRS	Circuit Emulation Service. Cell Relay Service.
Line Type	Extended Superframe	Extended Superframe Superframe NotApplicable	Only for CES mode.
Loopback Config	None	None Facility Line	No Loopback has been activated. Activates a facility loopback.
Far End Loopback	None	None Payload Reset Line	No loopback has been requested for far end. Options only available with FDL on. Requests a Payload loopback for far end. Resets a loopback at the far end. Requests a loopback for the line at the far end.

(continued)

Table 754-2. T3 TMUX Multi 1 T1 Channel Configuration Options ,continued

SELECTION	DEFAULT	OPTIONS	DEFINITIONS
Facility Data Link	None	None ANSI T1-403 FDL	A peer-to-peer protocol across a T1 line providing OA&M functions (performance monitoring, loop back etc.) implemented via the framing bits in the T1 frame.
Circuit Identifier	<blank>	Any alphanumeric characters, up to 20?	User defined. Usually describes the traffic, customer, and/or channel number.
Line Coding	AMI	AMI	Alternate Mark Inversion format. Not selectable by user.

Table 754-3. ATM Interface Configuration Options for CRS Mode

SELECTION	DEFAULT	OPTIONS	DEFINITIONS
Interface Name	<default>	Alphanumeric	User defined, up to 20 alphanumeric characters.
Loopback Location Code	All 1s	Alphanumeric	Used to loopback the incoming signal and transmit it back to the customer equipment. The code is limited to 16 numeric characters.
Recording Interface ID	All 0s	Numeric	Identifies the site card and port location for customer billing capabilities, (allows assignment of a customer ID for each port.) The code is limited to 15 numeric characters.
Provisioned Endpoints			Displays how many VPC or VCC endpoints are configured by administrator on this card.
Interface Type	UNI	UNI NNI	Specifies interface type as User to Network Interface or Network to Network Interface.
CAC Formula	PCR	PCR SCR	Specifies Peak Cell Rate or Sustained Cell Rate for Connection Admission Control.
Policing	Off	On or Off	User sets whether traffic will be policed for Quality Of Service (QOS).
Cell Scrambling	Off	On or Off	User sets whether traffic will be scrambled.
Over Subscription Rate	<blank>		User sets depending on traffic contract.
Max Active VPI Bits	0	0 to 8	Sets the maximum number of bits that may be utilized from this port.
Max Active VCI Bits	0	0 to 12	Sets the maximum number of bits that may be utilized from this port.
Max number of VPCs	4096	0 to 256	Sets the maximum number of VPCs that may be utilized from this port.
Max number of VCCs	0	0-8192	Sets the maximum number of VCCs that may be utilized from this port.

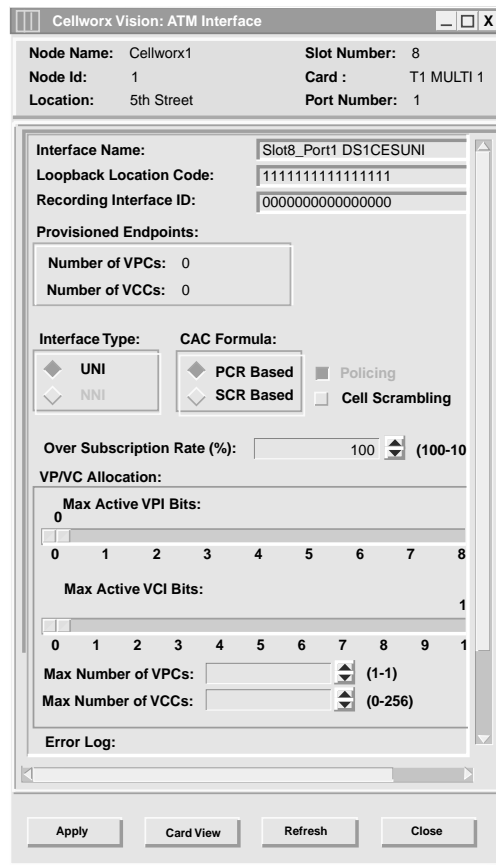

13431-A

Figure 754-3. ATM Interface Menu Options

Table 754-4. Configuration Options for CES Mode

SELECTION	DEFAULT	OPTIONS	DEFINITIONS
Interface Name	<default>	Alphanumeric	User defined, up to 20 alpha numeric characters.
ATM VPI	<user defined>	0-8	This is a read only to show the available bits configured for this port during connection creation.
ATM VCI	<user defined>	0-10	This is a read only to show the available bits configured for this port during connection creation.
Operational State	Up	Up/Down	This is a read only to show the state of the port.
Buffer Maximum Size	<default>	5300 to 6220	Maximum size measured in microseconds and selectable in 10 microsecond increments.
Cell Arrival Jitter Tolerance	<default>	950 to 2650	Maximum size measured in microseconds and selectable in 10 microsecond increments.
CBR Clock Mode	<default>	Adaptive or Synchronous	Sets the Constant Bit Rate clock to either adapt to the incoming bit stream or look for a constant synchronous bit stream.

DLP-754  
Page 7 of 7

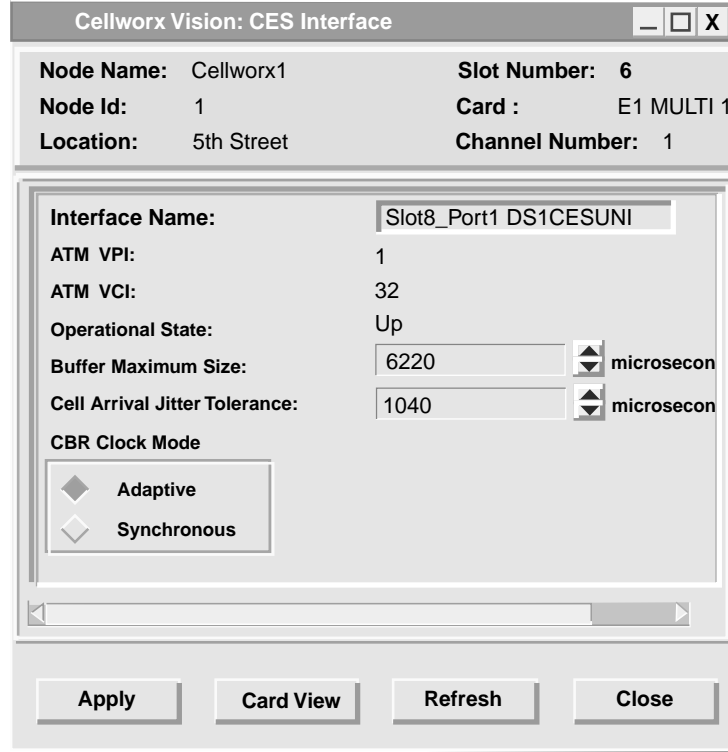

14547-A

Figure 754-4. CES Interface Menu Options

## SET T1 MULTI 1 CARD CONFIGURATION

**Summary:** This procedure details the steps required to set the T1 Multi 1 card configurations utilizing the Cellworx STN Phase 3.1 shelf level Graphical User Interface (GUI). User must have the GUI launched, and have accessed the shelf level GUI display per NTP-006 prior to performing this procedure.

1. Double click on the T1 Multi 1 card displayed in the shelf level GUI “Chassis View” at the top of the window. The T1 or E1 Multi 1 card display appears as shown in Figure 755-1.
2. Click and drag the small block upward to expand the Configuration section of the window so all or most options are visible. The Administrative State of the card and port should be “Unlocked” if in service. If “Locked”, select the “**Unlocked**” option using the left mouse button to enable the card and/or port for service.
3. Select a Port on the simulated card using the left mouse button.
4. Set the Port Level configuration options per requirements. Refer to Table 755-1 for a list of options the user may select for this card type.
5. Hit the **Apply** button at the bottom of the window to back up the new configuration data to the shelf controller.
  - ▶ **Note:** Selecting **Chassis View** will return the user to the previous window without closing the T1 Multi 1 window. Selecting **Refresh** will update the current window display with all the selections last recorded by the Shelf Controller card. Selecting **Close** will close this window.
6. If configuring the port for Cell Relay Service, continue with step 7. If configuring the port for Circuit Emulation Service, go to step 13.

## B. ATM INTERFACE CONFIGURATION (CRS MODE)

7. Double click on one of the ports available (1 to 16). The ATM interface screen appears. Refer to the example shown in Figure 755-2.
8. Set the ATM configuration options as needed. Table 755-2 shows a list of options the user may select.
9. Select the **Close** button to return to the T1 card display.
10. Repeat steps 3 through 6 for each T1 Multi 1 port on the card.
11. Select the **Close** button to return to the Chassis View window.
12. Repeat steps 1 through 11 for each card in the shelf.



## DLP-755

Page 2 of 5

## C. CES INTERFACE CONFIGURATION

13. Single click on the port to be assigned as a Circuit Emulation Service port.
14. Select the *Circuit Emulation Service* option on the Port Level Service Type followed by the *Apply* button at the bottom of the screen.
15. Double click on the port to bring up the CES interface screen. Refer to the example shown in Figure 755-3.
16. Set the CES configuration options as needed using Table 755-3 as a reference.
17. Select the *Apply* button and then the *Close* button to return to the T1 card display.
18. Repeat steps 3 through 6 for each T1 Multi 1 port on the card.
19. Select the *Close* button to return to the Chassis View window.
20. Repeat steps 1 through 20 for each card in the shelf.

**Stop! You have completed this procedure.**

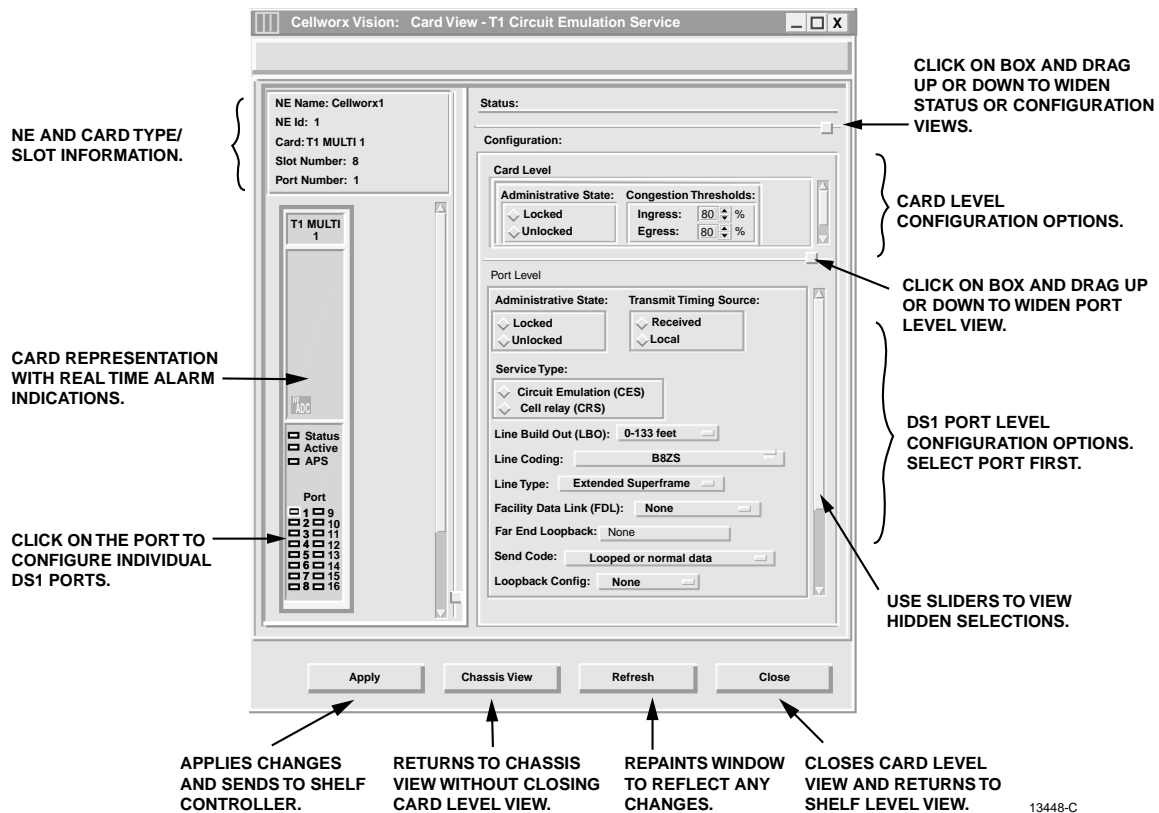

Figure 755-1. T1 Multi 1 Card Configuration Window

Table 755-1. T1 Multi 1 Configuration Options

SELECTION	DEFAULT	OPTIONS	DEFINITIONS
Card and Port Administrative State	Unlocked	Unlocked Locked	Enables or disables card for service.
Congestion Threshold	0	0 to 100	Threshold for CLP=1 cells to be discarded on the ingress/egress path.
Ring Selection	Auto	Auto Ring 16 Ring 17	Card will automatically select traffic from the ring direction with the best signal. Card will receive traffic from Ring 16 direction. Card will receive traffic from Ring 17 direction.
Transmit Timing Source	Local	Received Local	The Tx clock (and data rate) is the same frequency as the RX clock and data rate, (receive clock is looped to the transmitter). The on-board crystal oscillator is used for the clock source and will not equal the receive clock frequency.
Service Type	CES	CES CRS	Circuit Emulation Service. Cell Relay Service.
Line Build Out	0-133 feet	0 – 133 ft 133 – 266 ft 266 – 399ft 399 – 533ft 533 – 655	Sets the signal strength according to the distance in feet that the Cellworx STN is from the T1 interfacing equipment.
Line Coding	B8ZS	B8ZS AMI	Bit 8 Zero Substitution Alternate Mark Inversion
Line Type	Extended–Superframe	Extended–Superframe Superframe	Sets the line type to reflect customer equipment on a per port basis.
Facility Data Link	None	ANSI-T1-403 FDL None	A peer-to-peer protocol across a T1 line providing OA&M functions (performance monitoring, loop back etc.) implemented via the framing bits in the T1 frame.
Far End Loopback	Looped or Normal Data	None Reset Line Payload	No loopback is requested. Values only selectable when FDL is on. Tells far end to stop the loopback. Tells far end to loop the line back. Tells the far end to loop the payload after line data is extracted.

(continued)

Table 755-1. T1 Multi 1 Configuration Options, continued

SELECTION	DEFAULT	OPTIONS	DEFINITIONS
Loopback Config	None	None Facility Payload  Terminal  Facility Line	No loopback activated on this card.  Loops the payload after line data is extracted.  Sends cells to the cellbus and back to the ring. No changes are made to the payload.  Loops the incoming signal back to CPE, generates AIS to the cellbus.
Circuit Identifier	<blank>	Up to 20 alphanumeric characters.	User defined. Usually describes the traffic, customer, and/or channel number.

Table 755-2. ATM Interface Configuration Options for CRS Mode

SELECTION	DEFAULT	OPTIONS	DEFINITIONS
Interface Name	<default>	Alphanumeric	User defined, up to 20 alpha numeric characters.
Loopback Location Code	All 1s	Alphanumeric	Used to loopback the incoming signal and transmit it back to the customer equipment. The code is limited to 16 numeric characters.
Recording Interface ID	All 0s	Numeric	Identifies the site card and port location for customer billing capabilities, (allows assignment of a customer ID for each port.) The code is limited to 15 numeric characters.
Provisioned Endpoints			Displays how many VPC or VCC endpoints are configured by administrator on this card.
Interface Type	UNI	UNI NNI	Specifies interface type as User to Network Interface or Network to Network Interface.
CAC Formula	PCR	PCR Based SCR Based	Specifies Peak Cell Rate or Sustained Cell Rate for Connection Admission Control.
Policing	Off	On or Off	User sets whether traffic will be policed for Quality Of Service (QOS).
Cell Scrambling	Off	On or Off	User sets whether traffic will be scrambled.
Over Subscription Rate	<blank>		User sets depending on traffic contract.
Max Active VPI Bits	0	0 to 8	Sets the maximum number of bits that may be utilized from this port.
Max Active VCI Bits	0	0 to 12	Sets the maximum number of bits that may be utilized from this port.
Max number of VPCs	256	0 to 256	Sets the maximum number of VPCs that may be utilized from this port.
Max number of VCCs	0	0-8192	Sets the maximum number of VCCs that may be utilized from this port.

DLP-755  
Page 5 of 5

Table 755-3. Configuration Options for CES Mode

SELECTION	DEFAULT	OPTIONS	DEFINITIONS
Interface Name	<default>	Alphanumeric	User defined, up to 20 alpha numeric characters.
ATM VPI	<user defined>	0-8	This is a read only to show the available bits configured for this port during connection creation.
ATM VCI	<user defined>	0-10	This is a read only to show the available bits configured for this port during connection creation.
Operational State	Up	Up/Down	This is a read only to show the state of the port.
Buffer Maximum Size	<default>	5300 to 6220	Maximum size measured in microseconds and selectable in 10 microsecond increments.
Cell Arrival Jitter Tolerance	<default>	950 to 2650	Maximum size measured in microseconds and selectable in 10 microsecond increments.
CBR Clock Mode	<default>	Adaptive or Synchronous	Sets the Constant Bit Rate clock to either adapt to the incoming bit stream or look for a constant synchronous bit stream.

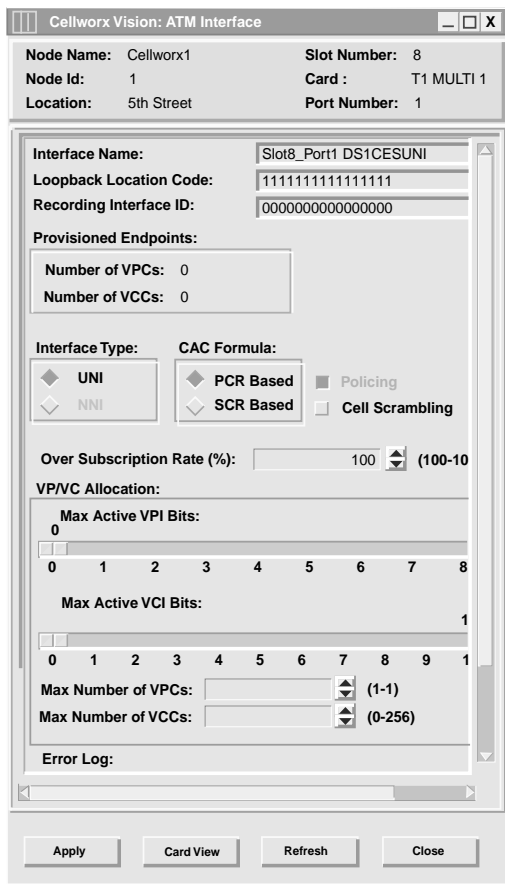

13431-A

Figure 755-2. T1 Multi 1 ATM Interface Options



14547-A

Figure 755-3. CES Interface Menu Options

## SET 2488 RING INTERFACE CARD (RIC) CONFIGURATION

**Summary:** This procedure details the steps required to set the 2488 Ring Interface Card configurations utilizing the Cellworx STN Phase 3.1 shelf level Graphical User Interface (GUI). User must the have GUI launched and accessed the shelf level GUI display per NTP-006 prior to performing this procedure.

1. Double click on the 2488 RIC located in slot 16 or 17 in the shelf level GUI “Chassis View” at the top of the window. The 2488 card level display appears similar to Figure 756-1.
2. Set the configuration options for the card and port using Table 756-1 as a reference for the options.
3. Select the **Apply** button at the bottom of the window to send the new configuration data to the shelf controller.

► **Note:** Selecting **Chassis View** will return the user to the previous window without closing the 2488 RIC window. Selecting **Refresh** will update the current window display and all the selections last recorded by the Shelf Controller card. Selecting **Close** will close this window.

4. Repeat steps 1 through 4 for the second 2488 RIC card installed in the shelf.

**Stop! You have completed this procedure.**

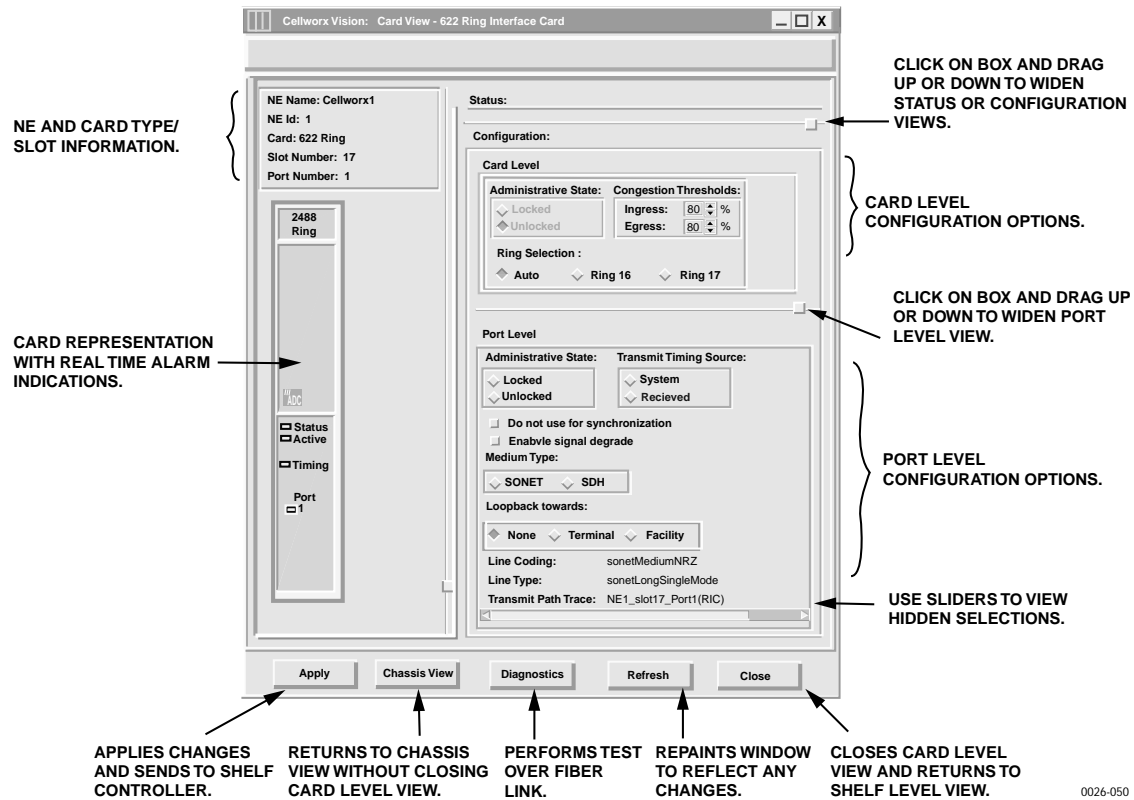

Figure 756-1. 2488 RIC Shelf Level GUI Configuration Screen

Table 756-1. 2488 RIC Card Configuration Options

SELECTION	DEFAULT	OPTIONS	DEFINITION
Admin State	Unlock	Lock / Unlock	Not configurable on RIC.
Congestion Threshold	80	0-100	Percentage of buffer capacity that will cause a congestion threshold notification.
Ring Selection	Auto	Auto Ring 16 Ring 17	Not configurable on RIC.
Transmit Timing Source	System	System Received	Uses Primary timing reference. Uses clock derived from incoming receive fiber (also known as Line-Timing).
Do Not Use for Sync	False	Selected (true) Not selected (false)	If "True", causes the RIC to output DUS (Do not Use for Sync) in the S1 byte of the SONET overhead.
Enable Signal Degrade	Not Selected	Selected Not Selected	Enables a protection switch of the traffic if the input signal strength drops below tolerable levels set by the user in the BER threshold selection.

(continued)

Table 756-1. 2488 RIC Configuration Options, continued

SELECTION	DEFAULT	OPTIONS	DEFINITION
Signal Degrade BER Threshold	5	5 through 9	Defines the number of bit errors the port can incur before a signal degrade occurs and generates an alarm message and probably protection switch.
Medium Type	SONET	SONET SDH	Not configurable on RIC. This is determined by the dip-switch on the SC EIM, which sets the shelf type.
Loopback towards	None	None Terminal Facility	No loopback activated on this card. Sends cells back to the cellbus and back out to the ring. No changes are made to the path layer data. Loops the incoming signal back to the CPE and generates AIS to the cellbus.
Line Coding	NRZ		Not configurable by user.
Line Type	Card Dependant	sonetOther sonetShortSingle Mode sonetLongSingle Mode sonetMultiMode	Not configurable by user, card type dependant on card inserted.
Transmit Path Trace	(example) NE1_Slot17_ Port1 (OC48)		Card position dependent. This is assigned by the system according to the NE and slot it is equipped in.

## RETRIEVE SC CARD STATUS

**Summary:** This procedure defines the information retrieved from the shelf-level GUI card status display for the SC card. User must have the GUI launched and accessed the shelf level GUI display per NTP-007 prior to performing this procedure.

1. Double click on the SC card located in the shelf level GUI “Chassis View” at the top of the window.
2. The SC card display appears as shown in Figure 757-1. Click the small block between the Status and Configuration sections and drag it downwards to view all the status information. Refer to Table 757-1 for definitions of status information provided.
3. Select the *Close* button to close the screen and return to the chassis view.

**Stop! You have completed this procedure.**

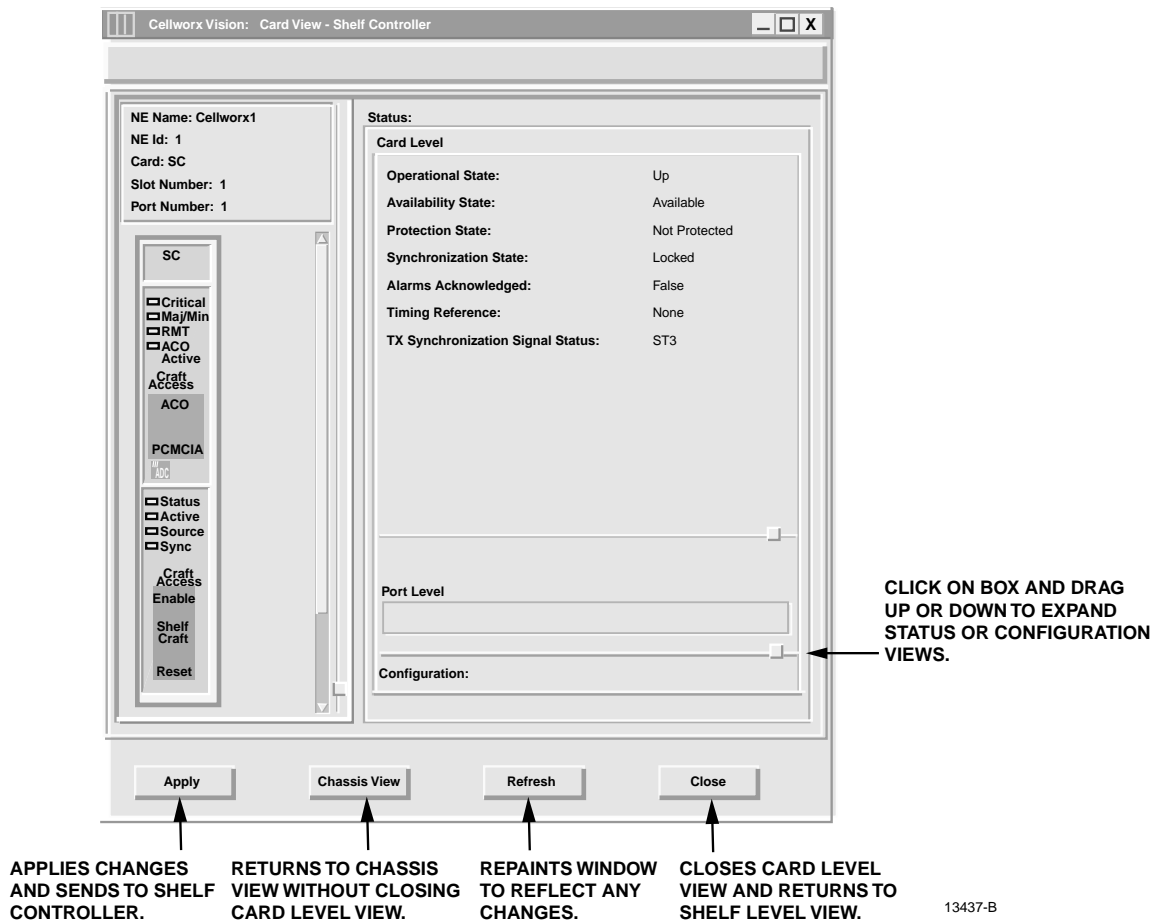

Figure 757-1. SC Card Status Window



DLP-757  
Page 2 of 3

Table 757-1. Shelf Controller Status Definitions

ITEM	STATUS	DEFINITION	ACTION
Operational Status	Up	Card is installed and functioning properly.	No action required.
	Down	Card is not functioning properly, is in reset mode, or failed.	Verify card is installed, check for failure indications and alarms.
	Unknown	The system processor does not currently know the operational	Wait a few seconds for system to complete its operations and then update the screen.
Availability State	Available	Card is ready for processing commands.	No action required.
	Unavailable	Card is in standby mode or busy processing commands.	Wait a few moments and recheck status.
	In Test	Card is currently in a test mode.	Wait a few moments and recheck status.
	Failed	Card requires operator intervention.	On site replacement of failed SC card. Refer to DLP-777.
	Power off	No power is applied to card.	Check power source. Replace card if necessary per DLP-777.
	Not Installed	Card is not physically installed into the backplane.	Try other SC card slot, install missing card if required. Per DLP-777.
	Offline	Card is installed but not in service.	No action required.
	Dependency	Card is supplying timing reference, traffic, or other data to the system.	Perform a soft switch over (manual) per DLP-771 to release card dependency if removing.
Protection State	Enabled	Protection operation is supported.	No action required.
	Not Protected	No protection card is available.	Add or replace the inactive SC card per DLP-777.

(continued)

Table 757-1. Shelf Controller Status Definitions, Continued

ITEM	STATUS	DEFINITION	ACTION
Synchronization State	Locked	Card is currently in sync with the reference source.	No action required.
	Unlocked	Card is not currently in sync with reference source.	Allow a minimum of 5 minutes for cards to sync up to reference, then check configuration and monitor source.
Alarms Acknowledged	No	Alarm Cut Off condition is not currently active.	No action required.
	Yes	Alarm Cut Off has been initiated to silence audible alarms.	ACO will deactivate upon a new alarm condition. Activate if required per DLP-776 .
Timing Reference	DB7	SC is providing clock for cell bus 7.	No action required. If a card will be removed, it is best to perform a switch over to the stand-by card first. Refer to DLP-771.
	DB8	SC is providing clock for Cell bus 8.	
	Both Buses	SC is providing clock for both cell buses.	
	None	SC is not providing clock reference to any cell bus.	
TX Synchronization Signal Status	ST3 PRS STU ST2 SMC DUS	Non-Configurable. Indicates the quality of the SC clock signal to the shelf. TX Sync Status should match RX Sync Status if SC is locked to the timing reference. Status will show DUS while it is acquiring to the reference, and transmit ST3 while in holdover.	No action required. To select a different timing source, refer to DLP-749.

Table 757-2. Timing Reference Status Definitions

STATUS	DEFINITION
PRC	SDH Primary Reference Clock
PRS	Primary Reference Source
SEC	SDH Equipment Clock Traceable
SSU	SDH Sync Supply Unit Traceable
ST1	Stratum 1 level source
STU	Synchronized Traceability Unknown
ST2	Stratum 2 level source
ST3	Stratum 3 level source
SMC	SONET Minimum level Clock
DUS	Reference cannot be used for source

**DLP-758**

Page 1 of 3

**SET 155 RING INTERFACE CARD (RIC) CONFIGURATION**

**Summary:** This procedure details the steps required to set the 155 Ring Interface Card configurations utilizing the Cellworx STN Phase 3.1 shelf level Graphical User Interface (GUI). User must have the GUI launched and accessed the shelf level GUI display per NTP-006 prior to performing this procedure.

1. Double click on the 155 RIC located in slot 16 or 17 in the shelf level GUI “Chassis View” at the top of the window.
2. Set the configuration options for the card and port using Table 758-1 as a reference for descriptions of the selectable options.
3. Select the **Apply** button at the bottom of the window to send the new configuration data to the shelf controller.

► **Note:** Selecting **Chassis View** will return the user to the previous window without closing the 155 RIC window. Selecting **Refresh** will update the current window display and all the selections last recorded by the Shelf Controller card. Selecting **Close** will close this window and return the user to the Chassis View window.

4. Repeat steps 1 through 3 for the second 155 RIC card installed in the shelf.

**Stop! You have completed this procedure.**

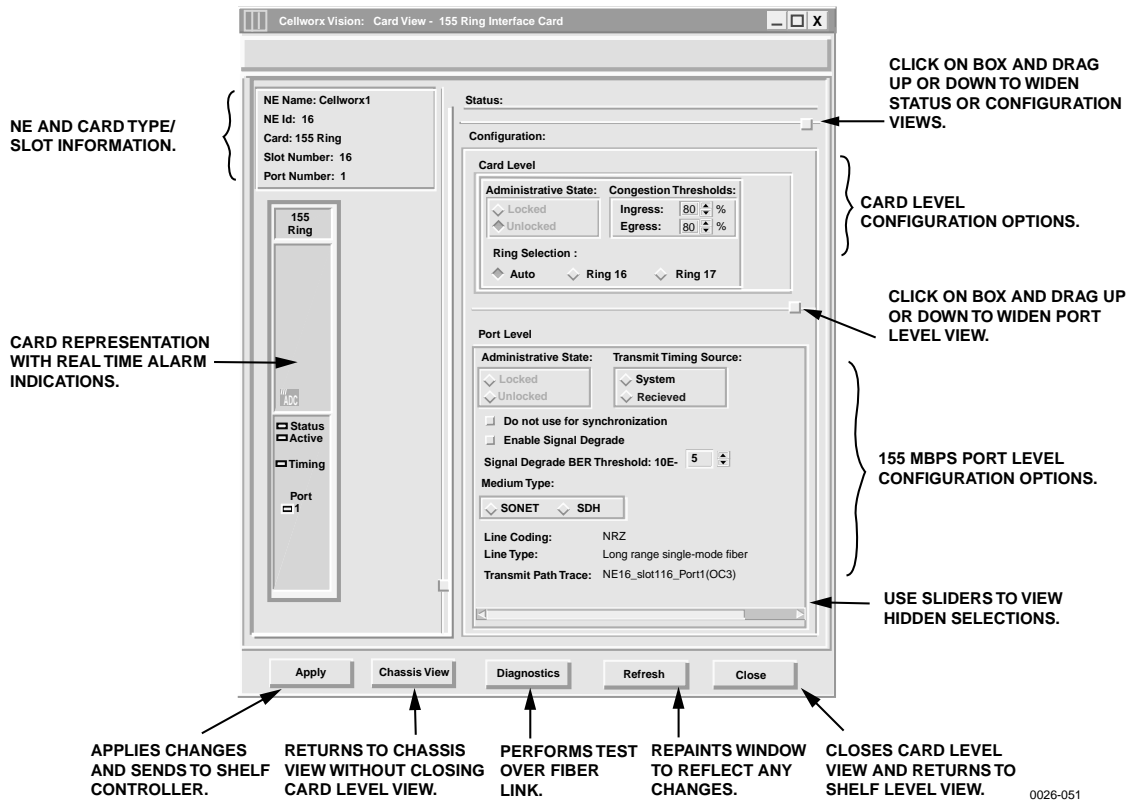

Figure 758-1. 155 RIC Configuration Screen

Table 758-1. 155 RIC Configuration Options

SELECTION	DEFAULT	OPTIONS	DEFINITION
Admin State	Unlock	Lock / Unlock	Disables or enables the card or port for service.
Congestion Threshold	80	0-100	Percentage of buffer capacity that will cause a congestion threshold notification.
Ring Selection	Auto	Auto Ring 16 Ring 17	Not configurable on RIC cards.
Transmit Timing Source	System	System Received	Uses Primary timing reference. Uses clock derived from incoming receive fiber (also known as Line-Timing).
Do Not Use for Sync	False	Selected (true) Not selected (false)	If "True", causes the RIC to output DUS (Do not Use for Sync) in the S1 byte of the SONET overhead.
Enable Signal Degrade	Not Selected	Selected Not Selected	Enables a protection switch of the traffic if the input signal strength drops below tolerable levels set by the user in the BER threshold selection.

(continued)

Table 758-1. 155 RIC Configuration Options, continued

SELECTION	DEFAULT	OPTIONS	DEFINITION
Signal Degrade BER Threshold	5	5 through 9	Defines the number of bit errors the port can incur before a signal degrade occurs and generates an alarm message and probably protection switch.
Medium Type	SONET	SONET SDH	Not configurable on RIC cards.
Loopback towards	None	None Terminal Facility	No loopback activated on this card. Sends cells back to the cellbus and back out to the ring. No changes are made to the path layer data. Loops the incoming signal back to the CPE and generates AIS to the cellbus.
Line Coding	NRZ		Not configurable by user.
Line Type	Card Dependent	sonetOther sonetShortSingle Mode sonetLongSingle Mode sonetMultiMode	Not configurable by user, type dependent on card installed. This will show sonetLongSingleMode for RICs and 155 SM cards, and sonetMultiMode for 155 MM cards.
Transmit Path Trace	(example) NE1_Slot17_ Port1 (OC48)		Card position dependent. This is assigned by the system according to the NE and slot it is equipped in.

### RETRIEVE 622 RING INTERFACE CARD (RIC) STATUS

**Summary:** This procedure defines the information retrieved from the shelf level GUI card status display for the 622 RIC card. User must have the GUI launched and accessed the shelf level GUI display per NTP-007 prior to performing this procedure.

1. Double click on the 622 RIC located in slot 16 or 17 in the shelf level GUI “Chassis View” at the top of the window.
2. Click the small block between the Status and Configuration sections and drag it downwards to view all the status information. Refer to Table 759-1 for definitions of status information provided.
3. Select the *Close* button to return to the shelf view.

**Stop! You have completed this procedure.**

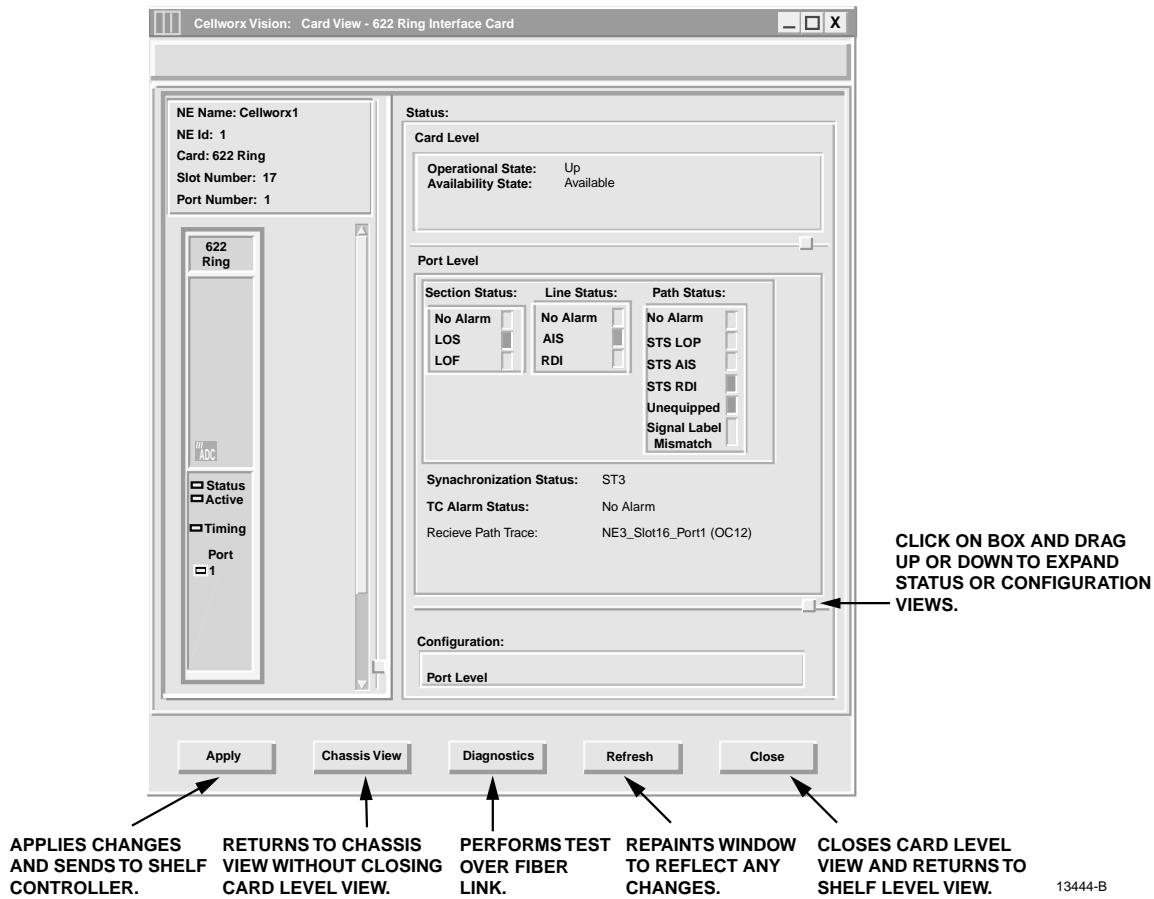

Figure 759-1. 622 RIC Status Window

Table 759-1. 622 RIC Card Status Definitions

ITEM	STATUS	DEFINITION	ACTION
<b>CARD</b>			
Operational State	Up	Card is functioning properly.	No action required.
	Down	Card is not functioning properly, is in reset mode, or failed. Check Admin state.	Verify card is installed, check for failure indications or provision card for service per DLP-751.
	Unknown	The system processor does not currently know the operational status.	Wait a few seconds for system to complete its operations and then refresh the screen.
Availability State	Available	Card is ready for processing commands.	No action required.
	In Test	Card is currently processing test signals.	Wait a few seconds for screen to update.
	Failed	Card has failed operation and system has placed it out of service.	Card may be performing a reset, or the bus may be busy.
	PowerOff	No power to the card.	Check power source. Replace card if source is good per DLP-777.
	Not Installed	Card is not installed.	If required, install card in selected slot per DLP-777 and provision per DLP-751.
	Offline	Card is installed and provisioned but currently off line.	If required, set module on line per DLP-751.
	Dependency	Card is supplying timing reference, traffic, or other data to the system.	Perform a soft switch over (manual) per DLP-771 to release card dependency if removing.
Unknown	The system processor does not currently know the availability status.	Wait for processor to update current status, may need to perform a manual reset of SC per DLP-773.	
<b>PORT</b>			
Section Status	No Alarm	No errors between local and next node.	No action required.
	LOS	Loss Of Signal (cannot locate section data)	Check connectors, fiber, and transmitter at other end.
	LOF	Loss Of Frame (cannot locate frame bit of section data)	Check signal type, and power level of received signal.
Line Status	No Alarm	Receiving good input signal	No action required.
	AIS	Alarm Indication Signal, inserted all 1s or blue signal at originating node.	Check signal status at traversing nodes, and low speed signal input at transmitting node.
	RDI	Remote Defect Indicator. Far end sending indication that it is receiving a defective signal.	Check local transmitting end signal for defects.

(continued)

## DLP-759

Page 3 of 3

Table 759-1. 622 RIC Status Definitions, continued

ITEM	STATUS	DEFINITION	ACTION
Path Status	No Alarm	Receiving good input signal.	No action required.
	STS LOP	STS signal Loss Of Pointer.	Check sync reference sources and input.
	STS AIS	STS Alarm Indication Signal.	Remote end transmitting AIS due to loss of payload for path.
	STS RDI	STS signal Remote Defect Indication.	Remote end informing local end it is receiving a defective signal.
	Unequipped Signal Label Mismatch	Unequipped time slot. Payload descriptor does not match overhead description.	This time slot is not being utilized. Check VP/VC connection for provisioning errors per DLP-704.
Sync Status (S1)	PRC	SDH Primary Reference Clock	Timing reference reliability levels. If sync status does not meet required level, check source and inputs. Provide the required clock source and change configuration settings for the card per DLP-749.
	PRS	Primary Reference Source	
	SEC	SDH Equipment Clock Traceable	
	SSU	SDH Sync Supply Unit Traceable	
	ST1	Stratum 1 level source	
	STU	Synchronized Traceability Unknown	
	ST2	Stratum 2 level source	
	ST3	Stratum 3 level source	
	SMC	SONET Minimum level Clock	
	DUS	Reference cannot be used for source	
Received Path Trace (J1)	User Defined	Path trace is a 64-character string assigned to a path between nodes in either direction identifying the transmitting node using the following format: NE<id>_Slot<slot#>_Port1 (OC12)	No action required. Path trace is not configurable by user.



## RETRIEVE 155 CRS STATUS

**Summary:** This procedure defines the information retrieved from the shelf level GUI card status display for the 155 CRS card. User must have the GUI launched and accessed the shelf level GUI display per NTP-007 prior to performing this procedure.

1. Double click on the 155 CRS card located in the shelf level GUI “Chassis View” at the top of the window.
2. Click the small block between the Status and Configuration sections and drag it downwards to view all the status information. Refer to Table 760-1 for definitions of status information provided.
3. Select the *Close* button to close the screen and return to the shelf view.

**Stop! You have completed this procedure.**

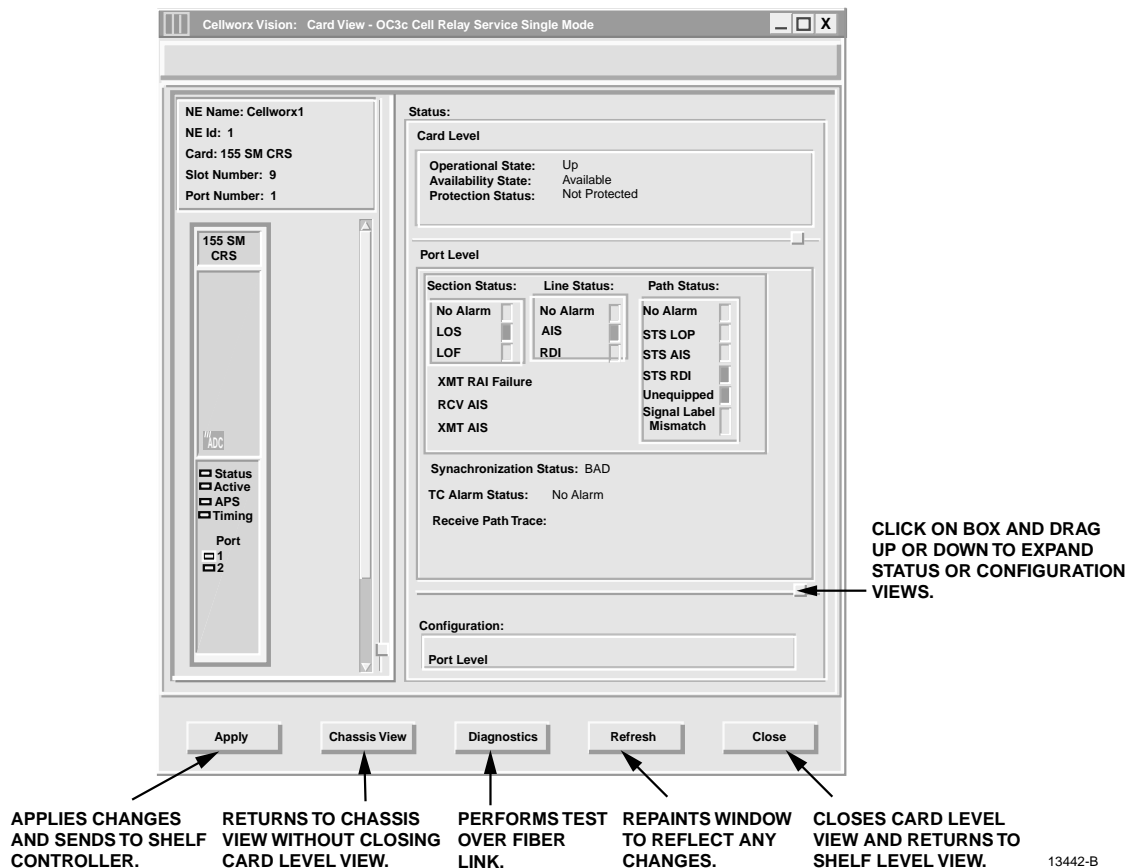

Figure 760-1. 155 CRS Card Status Window

## DLP-760

Page 2 of 3

Table 760-1. 155 CRS Card Status Definitions

ITEM	STATUS	DEFINITION	ACTION
Operational State	Up	Card is installed and provisioned for service.	No action required.
	Down	Card is not provisioned for service, is in reset mode, or failed.	Verify card is installed, check for failure indications or provision card for service per DLP-752.
	Unknown	The shelf controller does not currently know the operational status.	Wait a few seconds for operations to complete and update the screen.
Availability State	Available	Card is ready for processing commands.	No action required.
	In Test	Card is currently processing test signals.	Wait a few seconds for screen to update.
	Failed	Card has failed operation and system has placed it out of service.	Card may be performing a reset, or the bus may be busy.
	PowerOff	Card is manually powered off.	Check power source, replace card if source is good per DLP-777.
	Not Installed	Card is not currently installed in selected slot of the shelf.	If required, install card in selected slot per DLP-777 and provision per DLP-752.
	Offline	Card is installed and provisioned but currently off line.	If required, set module on line (unlocked) per DLP-752.
	Dependency	Card is supplying timing reference, traffic, or other data to the system.	Perform a soft switch over (manual) per DLP-771 to release card dependency if removing.
	Unknown	The shelf controller does not currently know the availability status.	Wait for processor to update current status, may need to perform a manual reset of SC per DLP-773.
Section Status	No Alarm	No errors between local and next node.	No action required.
	LOS	Loss Of Signal. Cannot locate section data.	Check connectors, fiber, and then transmitter at remote end.
	LOF	Loss Of Frame. Cannot locate frame bit of section data.	Check signal configuration and power level of received signal.
Line Status	No Alarm	Receiving good input signal.	No action required.
	AIS	Alarm Indication Signal. All 1s or blue signal inserted at originating node.	Check signal status at traversing nodes, and low speed signal input at transmitting node.
	RDI	Remote Defect Indicator.	Problem at transmitting end.
Path Status	No Alarm	Receiving good input signal.	No action required.
	STS LOP	STS signal Loss Of Pointer.	Check sync reference sources and inputs.

(continued)

Table 760-1. 155 Card Status Definitions, continued

ITEM	STATUS	DEFINITION	ACTION
Path Status (continued)	STS AIS	STS Alarm Indication Signal. Remote end transmitting AIS due to loss of payload for path.	Check remote transmitting end's input signal.
	STS RDI	STS Remote Defect Indication. Remote end is receiving a defective signal.	Check local end transmitter and connections.
	Unequipped	This time slot is not utilized (unequipped).	Create a connection if needed on this available timeslot per DLP-708.
	SignalLabel Mismatch	Type of signal does not match overhead description.	Check VP connection for provisioning errors per DLP-710.
Sync Status	PRC PRS SEC SSU ST1 STU  ST2 ST3 SMC DUS	SDH Primary Reference Clock Primary Reference Source SDH Equipment Clock Traceable SDH Sync Supply Unit Traceable Stratum 1 level source Synchronized Traceability Unknown Stratum 2 level source Stratum 3 level source SONET Minimum level Clock Reference cannot be used for source	Timing reference reliability levels. If sync status does not meet required level, check source and inputs. Provide the required clock source and change configuration settings for the card per DLP-749.  No action required.
Received Path Trace Msg (SM card only)	User Defined No Path Trace	Path trace is a 64-character string assigned to a path between nodes in either direction identifying the transmitting node.	No action required. If message states no path trace, one may be provisioned, for SM cards only, at either or both of the two adjacent nodes (clockwise and counter-clockwise node). Refer to DLP-752.
Protection State	Not Protected  Enabled  Manual switch  Forced Switch  Lockout  Unknown	Not Protected  Protection is available for selected card but is not active.  User has manually switched the card to protection.  User has forced card to protection.  Card cannot switch to protection. It has been locked out by command or switch count.  Protection status information is not available to the shelf controller.	If equipped, set up a protection group and provision card for protection per DLP-765.  No action necessary.  If required, switch the card back per DLP-771.  If required, release forced switch per DLP-771.  If required, release manual lock-out per DLP-771.  Wait a few minutes and update screen. May need to reset SC, refer to DLP-773.

### RETRIEVE T3 CRS CARD STATUS

**Summary:** This procedure defines the information retrieved from the shelf level GUI display for the T3 CRS card status. User must have the GUI launched and accessed the shelf level GUI display per NTP-007 prior to performing this procedure.

1. Double click on the T3 CRS card located in the shelf level GUI “Chassis View” at the top of the window.
2. Click the small block between the Status and Configuration sections and drag it downward to view all the status information. Refer to Table 761-1 for definitions of status information provided.
3. Select each port on the card to view the statuses.
4. Select the *Close* button at the bottom of the window to close the screen and return to the chassis level display.

**Stop! You have completed this procedure.**

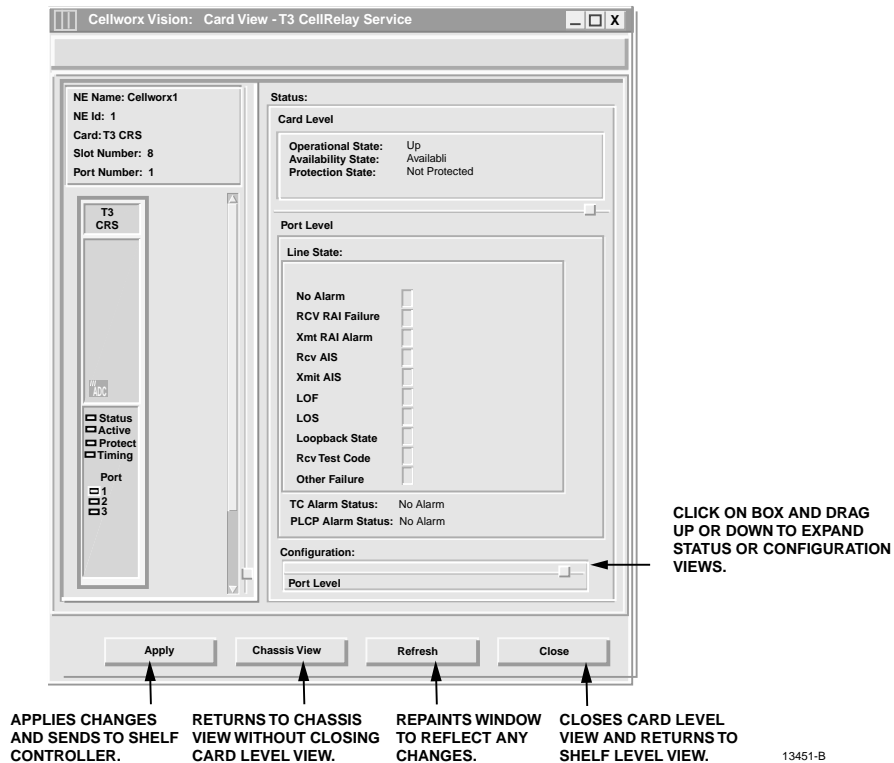

Figure 761-1. T3 CRS Card Status Window

Table 761-1. T3 CRS Card Status Definitions

ITEM	STATUS	DEFINITION	ACTION
Operational State	Up	Card is functioning properly.	No action required.
	Down	Card is not functioning properly, is in reset mode, or failed. Check Admin state.	Verify card is installed, check for failure indications, or provision card for service per DLP-753.
	Unknown	The shelf controller does not currently know the operational status.	Wait a few seconds for operations to complete and update the screen.
Availability State	Available	Card is ready for processing commands.	No action required.
	In Test	Card is currently processing test signals.	Wait a few seconds for screen to update.
	Failed	Card has failed operation and system has placed it out of service.	Card may be performing a reset, or the bus may be busy.
	Power Off	No power to the card.	Check power source, replace card if source is good.
	Not Installed	Card is not currently installed in selected slot of the shelf.	If required, install card in selected slot per DLP-777 and provision per DLP-753.
	Off Line	Card is installed and provisioned but currently off line.	If required, set module on line per DLP-753.
	Dependency	Card is supplying timing reference, traffic, or other data to the system.	Perform a soft switch over (manual) per DLP-771 to release card dependency if removing.
Unknown	The system processor does not currently know the availability status.	Wait for processor to update current status, may need to perform a manual reset of SC per DLP-773.	
Protection State	Not Protected	Not Protected	If equipped, set up a protection group and provision card for protection per DLP-765.
	Enabled	Protection is available for selected card but is not active.	No action necessary.
	Manual switch	User has manually switched the card to protection.	If required, switch the card back per DLP-771.
	Forced Switch	User has forced card to protection.	If required, release forced switch per DLP-771.
	Lockout	Card cannot switch to protection. It has been locked out by command or switch count.	If required, release manual lock-out per DLP-771.
	Unknown	Protection status information is not available to the shelf controller.	Wait a few minutes and update screen. May need to reset SC, refer to DLP-773.

(continued)

**DLP-761**  
Page 3 of 3

**Table 761-1. Display T3 Card Status Definitions, continued**

ITEM	STATUS	DEFINITION	ACTION
Line Status	No Alarm	T3 line is operating within normal parameters.	No action required.
	Rcv RAI Failure	Access interface (AIC) Receiving Remote Alarm Indication.	Check VP connection per DLP-710, and local access interface.
	Xmt RAI Alarm	Card transmitting a Remote Alarm Indication signal (RAI) to customer equipment.	Check VP connection per DLP-710, and remote transmit end.
	Rcv AIS	Card is receiving an Alarm Indication Signal (AIS).	Check remote end T3 input signal.
	Xmit AIS	Card is transmitting an AIS signal.	Check local T3 signal input.
	LOF	Input signal frame format not recognized.	Verify correct frame format setting and change if needed per DLP-753.
	LOS	No input signal being received.	Check metallic input and DSX.
	Loopback State	Card has been manually set to loop signal back to customer equipment.	Check customer end for troubleshooting activity. If required, release loopback per DLP-772.
	Rcv Test Code	Card is receiving a test signal input.	Check with administrator for testing activity.
	Other Failure	Card is experiencing a failure other than these listed.	

## RETRIEVE T3 TMUX MULTI 1 CARD STATUS

**Summary:** This procedure defines the information retrieved from the shelf level GUI display for the T3 TMUX MULTI1 card status. User must have the GUI launched and accessed the shelf level GUI display per NTP-007 prior to performing this procedure.

1. Double click on the T3 TMUX MULTI 1 card located in the shelf level view at the top of the window.
2. Click the small block between the Status and Configuration sections and drag it downward to view all the status information. Refer to Table 762-1 for definitions of status information provided. To view status information for the T3Tmux Multi 1, click on the tab for the first slot in the group. Click on the second slot tab for the TMUX EXP card.
3. To view a status of individual DS1 channels contained in a DS3, select a Channel Number at the upper right block above the simulated card and then click on the DS1 Channel tab under the Port heading. The window should appear similar to the one shown in Figure 762-2 displaying the DS1 port selected. Change the channel number above the simulated card as needed. Refer to Table 762-2 for DS1 port status definitions.
4. Select *Close* button to return to the chassis level view.

**Stop! You have completed this procedure.**

DLP-762  
Page 2 of 6

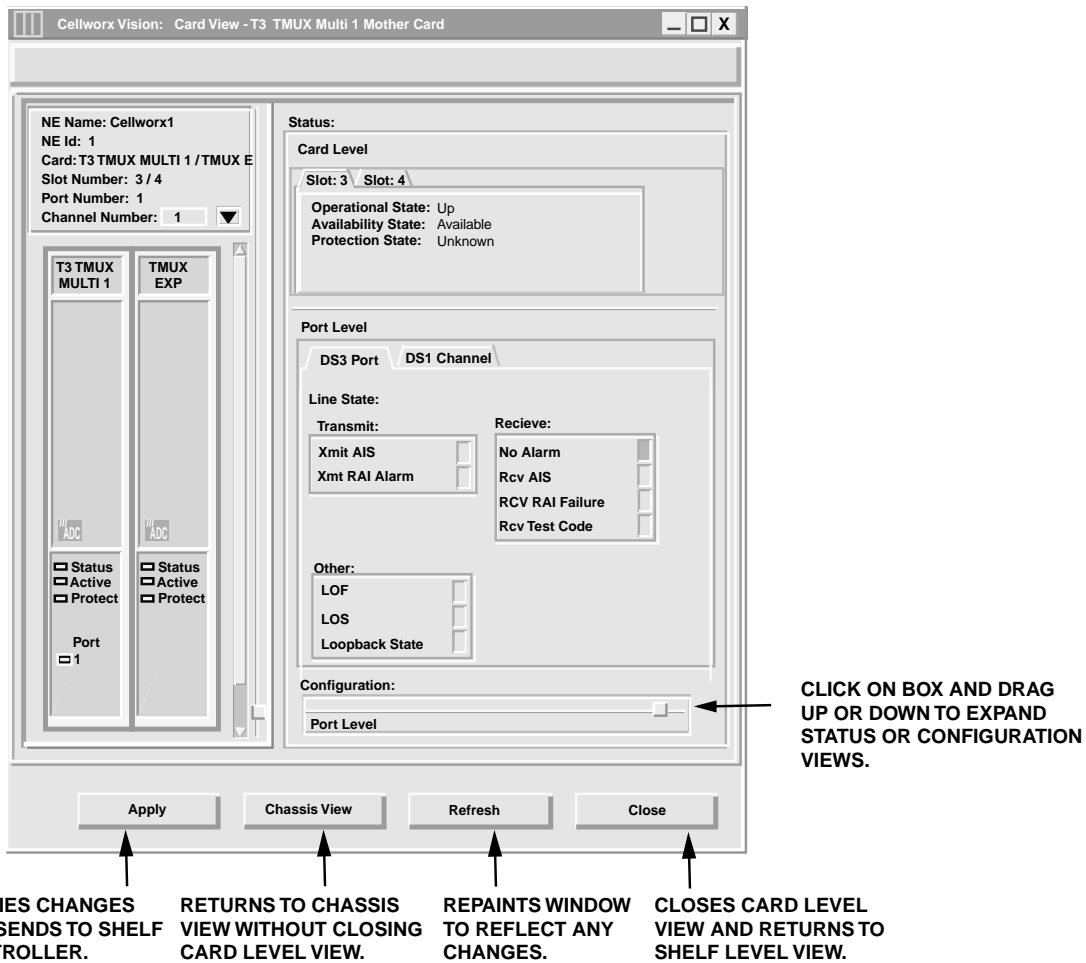

Figure 762-1. T3 TMUX Multi 1/TMUX EXP Card Status Window

Table 762-1. Display T3 TMUX Multi 1 and TMUX EXP Card Status Definitions

ITEM	STATUS	DEFINITION	ACTION
Operational State	Up	Card is functioning properly.	No action required.
	Down	Card is not functioning properly, is in reset mode, or failed. Check Admin state.	Verify card is installed, check for failure indications, or provision card for service per DLP-754.
	Unknown	The shelf controller does not currently know the operational status.	Wait a few seconds for operations to complete and update the screen.

(continued)



Table 762-1. Display T3 TMUX Multi 1 and TMUX EXP Card Status Definitions, continued

ITEM	STATUS	DEFINITION	ACTION
Availability Status	Available	Card is ready for processing commands.	No action required.
	In Test	Card is currently processing test signals.	Wait a few seconds for screen to update.
	Failed	Card has failed operation and system has placed it out of service.	Card may be performing a reset, or the bus may be busy.
	Power Off	No power to the card.	Check power source, replace card if source is good per DLP-777.
	Not Installed	Card is not currently installed in selected slot of the shelf.	If required, install card in selected slot per DLP-777 and provision per DLP-754.
	Off Line	Card is installed and provisioned but currently off line.	If required, set module on line per DLP-754.
	Dependency	Card is supplying timing reference, traffic, or other data to the system.	Perform a soft switch over (manual) per DLP-771 to release card dependency if removing.
	Unknown	The system processor does not currently know the availability status.	Wait for processor to update current status, may need to perform a manual reset of SC per DLP-773.
Protection State	Not Protected	Not Protected	If equipped, set up a protection group and provision card for protection per DLP-753.
	Enabled	Protection is available for selected card but is not active.	No action necessary.
	Manual switch	User has manually switched the card to protection.	If required, switch the card back per DLP-771.
	Forced Switch	User has forced card to protection.	If required, release forced switch per DLP-771.
	Lockout	Card cannot switch to protection. It has been locked out by command or switch count.	If required, release manual lock-out per DLP-771.
	Unknown	Protection status information is not available to the shelf controller.	Wait a few minutes and update screen. May need to reset SC, refer to DLP-773.

(continued)

**DLP-762**

Page 4 of 6

**Table 762-1. Display T3 TMUX Multi 1 and TMUX EXP Card Status Definitions, continued**

ITEM	STATUS	DEFINITION	ACTION
Transmit Line State	Xmt RAI Alarm	Card transmitting a Remote Alarm Indication signal (RAI) to customer equipment.	Check VP connection per DLP-709, and remote transmit end.
	Xmt AIS	Card is transmitting an AIS signal.	Check local T3 signal input.
Receive Line State	No Alarm	T3 line is operating within normal parameters.	No action required.
	Rcv AIS	Card is receiving an Alarm Indication Signal (AIS).	Check remote end T3 input signal.
	Rcv RAI Failure	Access interface (AIC) Receiving Remote Alarm Indication.	Check VP connection per DLP-709, and local access interface.
	Rcv Test Code	Card is receiving a test signal input.	Check with administrator for testing activity.
Other	LOF	Input signal frame format not recognized.	Verify correct frame format setting and change if needed per DLP-754.
	LOS	No input signal being received.	Check metallic input and DSX.
	Loopback State	Card has been manually set to loop signal back to customer equipment.	Check customer end for troubleshooting activity. If required, release loopback per DLP-772.

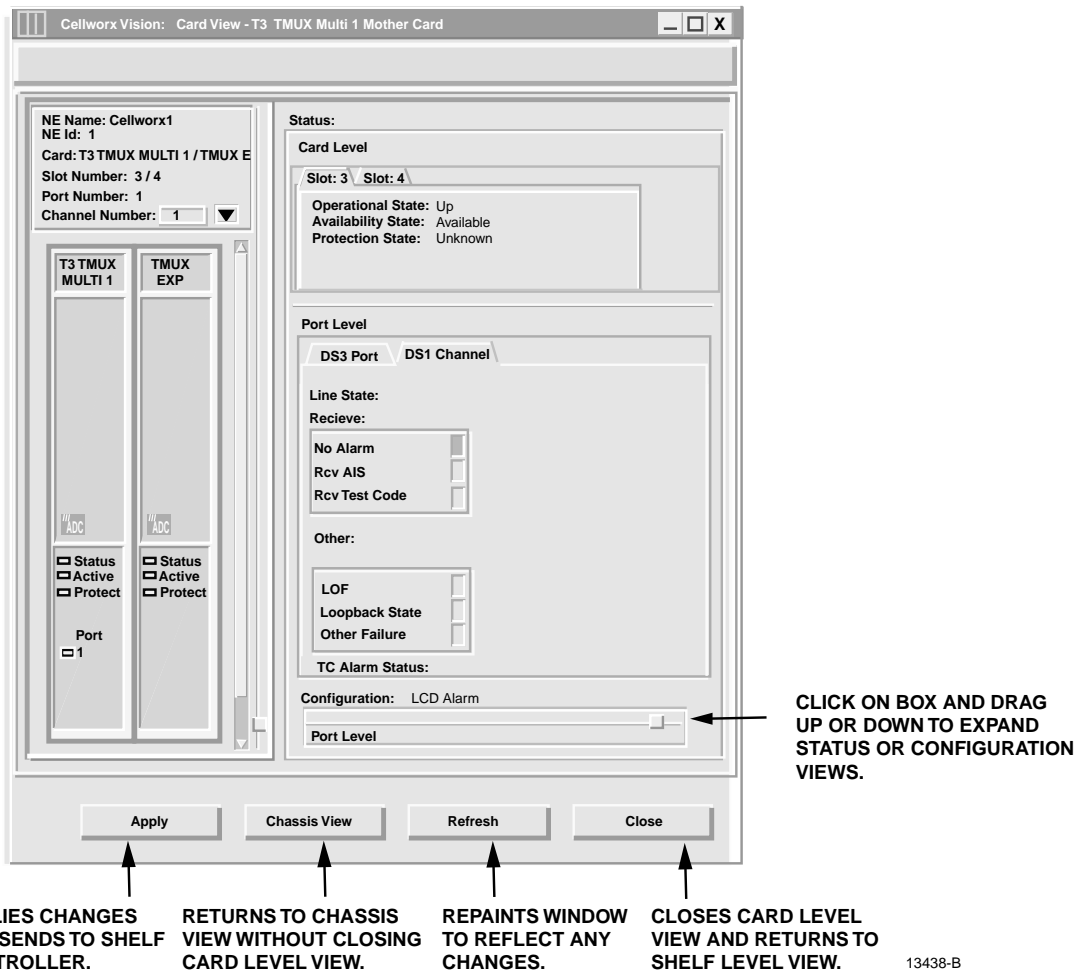

Figure 762-2. DS1 Channel Status Window

**DLP-762**

Page 6 of 6

**Table 762-2. T3 TMUX Multi 1/TMUX EXP DS1 Port Status Definitions**

ITEM	STATUS	DEFINITION	ACTION
DS1 Line State Receive	No Alarm	No alarms are present.	No action required.
	Rcv AIS	Alarm indication signal received from the far end.	Check framing format on local transmitting equipment or customer interfacing equipment..
	Rcv Test Code	Local end is receiving a test code generated by the remote end.	Check for troubleshooting activity on system. Release test signal at remote end.
Other	LOF	Loss of Frame	Check signal type and format.
	Loopback State	Indicates a loopback has been activated locally on this port.	Check for troubleshooting activity.
	Other Failure	Channel is experiencing a failure other than the ones listed here.	

## RETRIEVE 155 RING CARD STATUS

**Summary:** This procedure defines the information retrieved from the shelf level GUI display for the 155 Ring card status. User must have the GUI launched and accessed the shelf level GUI display per NTP-007 prior to performing this procedure.

1. Double click on the 155 Ring card located in the shelf level GUI “Chassis View” at the top of the window. These should be in slots 16 and 17.
2. The 155 Ring card display appears as shown in Figure 763-1. Click the small block between the Status and Configuration sections and drag it downward to view all the status information. Refer to Table 763-1 for definitions of status information provided.

**Stop! You have completed this procedure.**

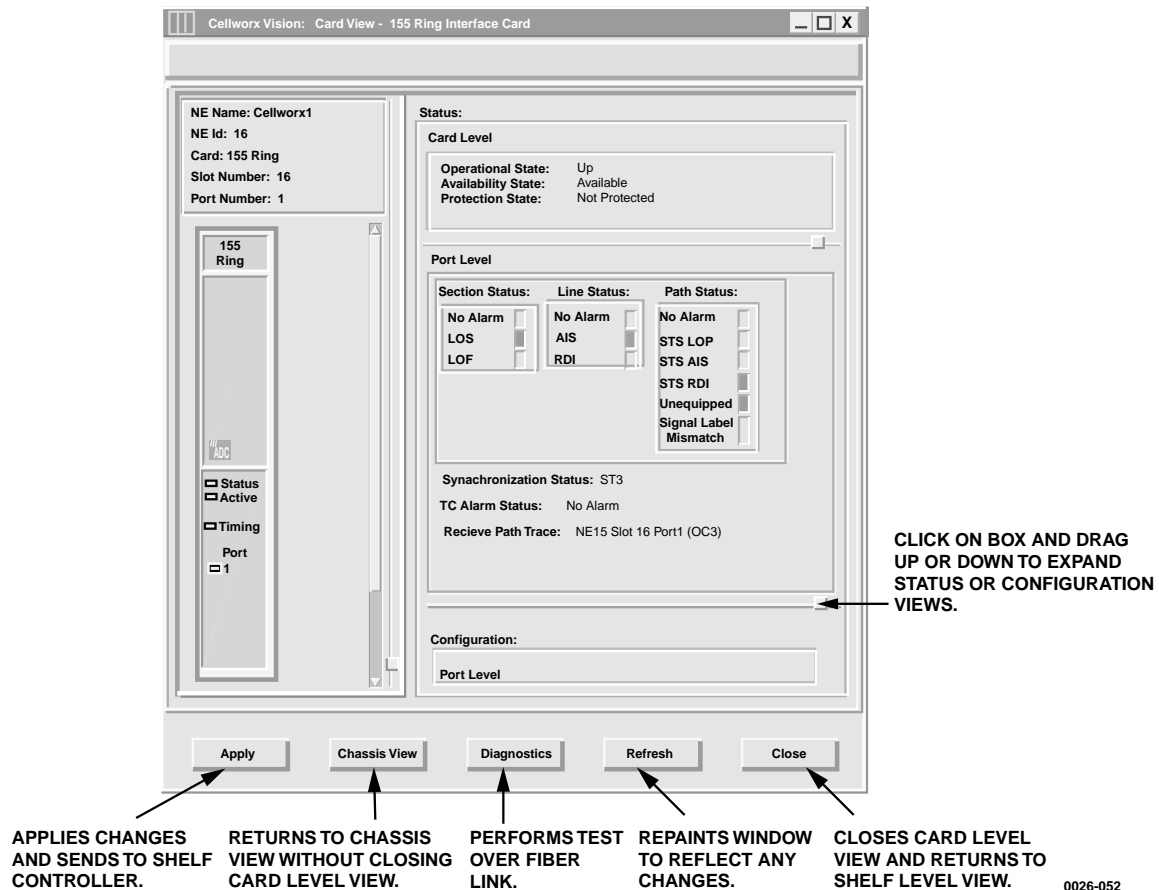

Figure 763-1. 155 Ring Card Status Display

**DLP-763**  
Page 2 of 3

Table 763-1. 155 RIC Card Status Definitions

ITEM	STATUS	DEFINITION	ACTION
<b>CARD</b>			
Operational State	Up	Card is functioning properly.	No action required.
	Down	Card is not functioning properly, is in reset mode, or failed. Check Admin state.	Verify card is installed, check for failure indications or provision card for service per DLP-758.
	Unknown	The system processor does not currently know the operational status.	Wait a few seconds for system to complete its operations and then update the screen.
Availability State	Available	Card is ready for processing commands.	No action required.
	In Test	Card is currently processing test signals.	Wait a few seconds for screen to update.
	Failed	Card has failed operation and system has placed it out of service.	Card may be performing a reset, or the bus may be busy.
	PowerOff	No power to the card.	Check power source. Replace card if source is good per DLP-777.
	Not Installed	Card is not installed.	If required, install card in selected slot per DLP-777 and provision per DLP-758.
	Offline	Card is installed and provisioned but currently off line.	If required, set module on line per DLP-758.
	Dependency	Card is supplying timing reference, traffic, or other data to the system.	Perform a soft switch over (manual) per DLP-771 to release card dependency if removing.
	Unknown	The system processor does not currently know the availability status.	Wait for processor to update current status, may need to perform a manual reset of SC per DLP-773.
<b>PORT</b>			
Section Status	No Alarm	No errors between local and next node.	No action required.
	LOS	Loss Of Signal, cannot locate section data.	Check connectors, fiber, and transmitter at other end.
	LOF	Loss Of Frame, cannot locate frame bit of section data.	Check signal type, and power level of received signal.
Line Status	No Alarm	Receiving good input signal	No action required.
	AIS	Alarm Indication Signal, inserted all 1s or blue signal at originating node.	Check signal status at traversing nodes, and low speed signal input at transmitting node.
	RDI	Remote Defect Indicator.	

(continued)

Table 763-1. 155 RIC Status Definitions, continued

ITEM	STATUS	DEFINITION	ACTION
Path Status	No Alarm	Receiving good input signal.	No action required.
	STS LOP	STS signal Loss Of Pointer.	Check sync reference sources and input.
	STS AIS	STS Alarm Indication Signal.	Remote end transmitting AIS due to loss of payload for path.
	STS RDI	STS signal Remote Defect Indication.	Remote end informing local end it is receiving a defective signal.
	Unequipped Signal Label Mismatch	Unequipped time slot. Payload descriptor does not match overhead description.	This time slot is not being utilized. Check VP/VC connection for provisioning errors per DLP-704.
Sync Status (S1)	PRC	SDH Primary Reference Clock	Timing reference reliability levels. If sync status does not meet required level, check source and inputs. Provide the required clock source and change configuration settings for the card per DLP-749.
	PRS	Primary Reference Source	
	SEC	SDH Equipment Clock Traceable	
	SSU	SDH Sync Supply Unit	
	ST1	Traceable	
	STU	Stratum 1 level source	
	ST2	Synchronized Traceability	
	ST3	Unknown	
SMC	Stratum 2 level source	No action required.	
DUS	Stratum 3 level source SONET Minimum level Clock Reference cannot be used for source		
Received Path Trace (J1)	User Defined	Path trace is a 64-character string assigned to a path between nodes in either direction identifying the transmitting node using the following format: NE<id>_Slot<slot#>_Port1 (RIC)	No action required. Path trace is not configurable by user.

## DLP-764

Page 1 of 3

## RETRIEVE T1 MULTI 1 CARD STATUS

**Summary:** This procedure defines the information retrieved from the shelf level GUI display for the T1 Multi 1 CRS card status. User must have the GUI launched and accessed the shelf level GUI display per NTP-007 prior to performing this procedure.

1. Double click on the T1 Multi 1 CRS card located in the shelf level GUI “Chassis View” at the top of the window.
2. The T1 Multi 1 CRS card display appears as shown in Figure 764-1. Click the small block between the Status and Configuration sections and drag it downward to view all the status information. Refer to Table 764-1 for definitions of status information provided.
3. Select each port on the card to view the port status.
4. Select *Close* button to return to the chassis level view.

**Stop! You have completed this procedure.**

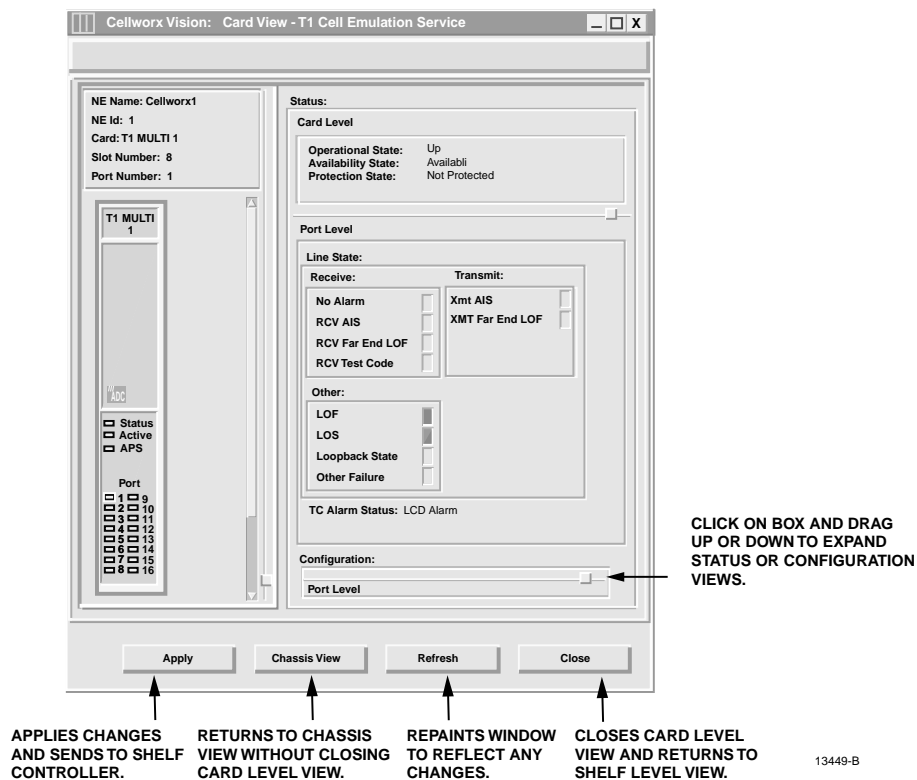

Figure 764-1. T1 Multi 1 Card Status Window



Table 764-1. Display T1 Multi 1 Card Status Definitions

ITEM	STATUS	DEFINITION	ACTION
Operational State	Up	Card is functioning properly.	No action required.
	Down	Card is not functioning properly, is in reset mode, or failed. Check Admin state.	Verify card is installed, check for failure indications, or provision card for service per DLP-755.
	Unknown	The shelf controller does not currently know the operational status.	Wait a few seconds for operations to complete and update the screen.
Availability State	Available	Card is ready for processing commands.	No action required.
	In Test	Card is currently processing test signals.	Wait a few seconds for screen to update.
	Failed	Card has failed operation and system has placed it out of service.	Card may be performing a reset, or the bus may be busy.
	Power Off	No power to the card.	Check power source, replace card if source is good per DLP-777.
	Not Installed	Card is not currently installed in selected slot of the shelf.	If required, install card in selected slot per DLP-777 and provision per DLP-755.
	Off Line	Card is installed and provisioned but currently off line.	If required, set module on line per DLP-755.
	Dependency	Card is supplying timing reference, traffic, or other data to the system.	Perform a soft switch over (manual) per DLP-771 to release card dependency if removing.
	Unknown	The system processor does not currently know the availability status.	Wait for processor to update current status, may need to perform a manual reset of SC per DLP-773.
Protection State	Not Protected	Not Protected	If equipped, set up a protection group and provision card for protection per DLP-753.
	Enabled	Protection is available for selected card but is not active.	No action necessary.
	Manual Switch	User has manually switched the card to protection.	If required, switch the card back per DLP-771.
	Forced Switch	User has forced card to protection.	If required, release forced switch per DLP-771.
	Lockout	Card cannot switch to protection. It has been locked out by command or switch count.	If required, release manual lock-out per DLP-771.
	Unknown	Protection status information is not available to the shelf controller.	Wait a few minutes and update screen. May need to reset SC, refer to DLP-773.

(continued)

**DLP-764**

Page 3 of 3

**Table 764-1. Display T1 Multi 1 Card Status Definitions, continued**

ITEM	STATUS	DEFINITION	ACTION
Line State	No Alarm	T3 line is operating within normal parameters.	No action required.
	Rcv AIS	Card transmitting a Remote Alarm Indication signal (RAI) to customer equipment.	Check VP connection per DLP-709, and remote transmit end.
	RCV Far End LOF	Card receiving a Loss Of Frame indication from far end NE.	Check VP connection per DLP-709, and local access interface.
	Xmt RAI Alarm	Access interface (AIC) Receiving Remote Alarm Indication.	Check remote end T3 input signal.
	Xmt Far End LOF	Transmit Far End Loss of Frame	
	Xmit AIS	Card is transmitting an Alarm Indication Signal (AIS).	Check local T3 signal input.
	LOF	Input signal frame format not recognized.	Verify correct frame format setting and change if needed per DLP-755.
	LOS	No input signal being received.	Check metallic input and DSX.
	Loopback State	Card has been manually set to loop signal back to customer equipment.	Check customer end for troubleshooting activity. If required, release loopback per DLP-772.
	Rcv Test Code	Card is receiving a test signal input.	Check with administrator for testing activity.
	Other Failure	Card is experiencing a failure other than these listed.	

## CONFIGURE CARD PROTECTION GROUPS

**Summary:** This procedure defines the steps required to create card protection groups using the shelf level GUI screens. Card protection capabilities are also addressed in this procedure. User must have launched the GUI and accessed the shelf level GUI screen prior to attempting this procedure. Refer to NTP-006.

1. From the shelf level GUI screen, select the **Configuration** menu using the left mouse button and then select **Protection Groups** or hit **ALT+N** and **Alt+P**. Refer to Figure 765-1.
  2. The Protection Groups and Protection Switch window appears as shown in Figure 765-2. Observe the cards equipped in the shelf and compare with work order. Card level protection capabilities are defined in Table 765-1. Select the **Protection Group Configuration** button.
  3. To configure a protection group, select the first card slot of the first protection group to be configured and at the bottom of the window enter a **Protection Group Number** value 1 through 8.
  4. Next select the **Protection Type** as 1:N, or 1+1.
  5. Enter the slot number of the first card in the protection group into the **First Slot** box at the bottom of the screen.
  6. Select the last card slot of the protection group by entering a slot number in the **Last Slot** box at the bottom of the window. This slot should either have a protection EIM (PEIM) installed (T1, T3, or T3 TMUX) or be a redundant optical card which does not require an EIM installed at the rear of the shelf.
  5. If applicable, select the **Revertive** box if revertive operation is desired and set the **Restore Time** in seconds for the system to automatically revert to the working card.
  6. Select the Protection Direction for the group as either **Unidirectional**, or **Bi-directional** (1+1 only, not 1:n).
- ◆ **Note:** OC3 and OC12 SEPIC cards must be configured for Bi-directional.
7. Select the **Apply** button at the bottom of the window to send new information to the SC database. This information will be backed up to the NMIC as changes are made.
  8. Repeat steps 3 through 7 for each protection group on the shelf or select the **Close** button at the bottom of the screen to return to the shelf level GUI screen.
  9. Select the next shelf in the network and repeat this procedure until all shelves are configured.

**Stop! You have completed this procedure.**

DLP-765  
Page 2 of 3

SELECT THE CONFIGURATION  
PULLDOWN MENU USING LEFT  
MOUSE BUTTON OR BY PRESSING  
THE ALT+N KEYS SIMULTANEOUSLY.

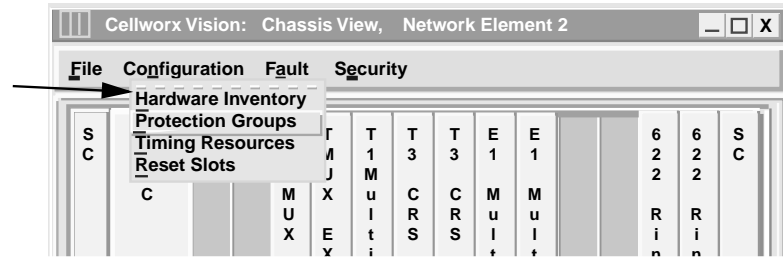

13470-B

Figure 765-1. Shelf Level GUI Configuration Pull Down Menu

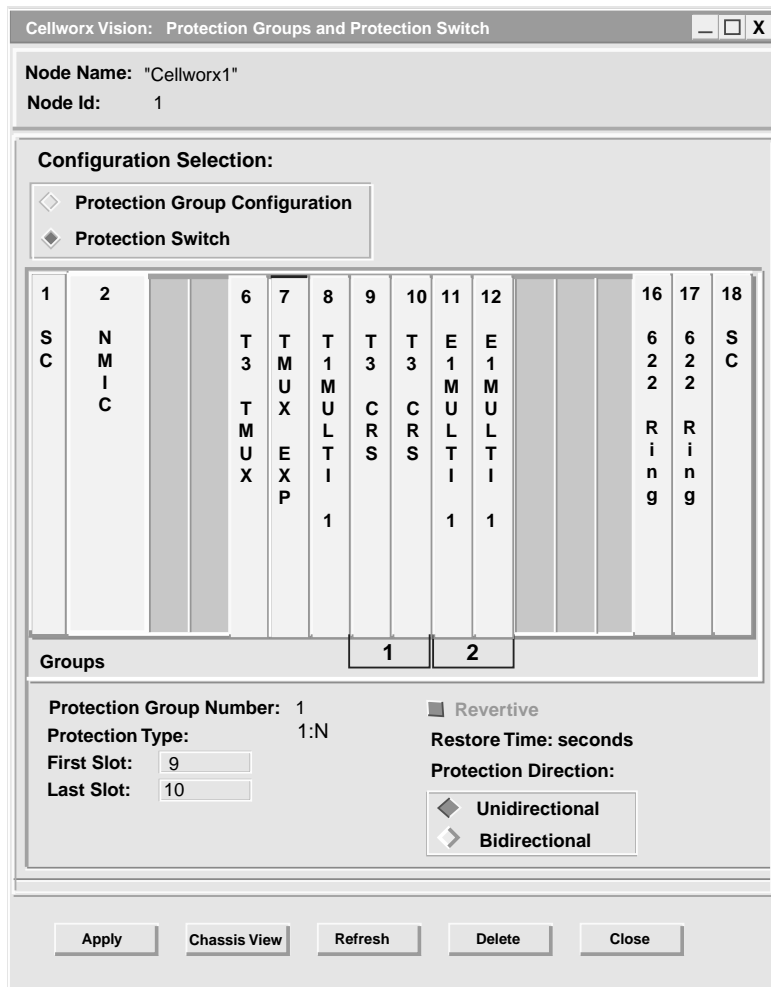

13468-C

Figure 765-2. Protection Groups and Protection Switch GUI Screen

Table 765-1. Card Protection Schemes

CARD TYPE	PROTECTION SCHEME	REQUIREMENTS
NMIC	1:1	Cards required at Gateway Node installed in adjacent slots. Working card in slots 2 and 3, protect card in slots 4 and 5. The ring network may operate with a minimum of one card but redundancy is recommended.
SC	1:1	Cards required in all Cellworx STN shelves, working in slot 1, protect in slot 18. Shelf may operate with a minimum of one card but redundancy is recommended.
622 Ring Card	N/A	All ring nodes must have cards installed in slots 16 and 17. Optical paths redundant though RICs which perform Automatic Virtual Path Switching (AVPS).
155 CRS	1+1	Cards must be installed in adjacent AIC slots starting with an even number. Dual port cards support two separate interfaces. If configured for SEPIC operation, the protection scheme MUST be set to Bi-directional.
T3 CRS	1:N (N ≤ 3)	Three ports per card will switch to protect with a single port failure. One group of contiguous slots across the backplane up to four total cards per group.
T3 TMUX Multi 1 / T3 EXP	1:N (N = 1)	One set of cards can be protected by a second set, or a single T3 TMUX can be protected by a redundant T3 TMUX.
T1 Multi 1	1:N (N ≤ 8)	One group of contiguous slots across the backplane up to nine total cards per group.
E1 Multi 1	1:N (N ≤ 8)	One group of contiguous slots across the backplane up to nine total cards per group.

## DLP-766

Page 1 of 3

### PERFORM DIAGNOSTICS ON OPTICAL CARDS

**Summary:** This procedure details the steps required to perform card level diagnostics on any of the 2488, 622, or 155 Ring or 155 CRS cards in a Cellworx STN shelf. The diagnostics provided allows the user to inject a Bit Interleaved Parity error (BIP) into the Section, Line, or Path of the optical signal to verify connectivity to the correct module or node, or just to verify the continuity.

User must have launched the Graphical User Interface and accessed the shelf level GUI before attempting this procedure. Refer to NTP-011.

1. From the GUI main display, select the node desired by double clicking on it using the left mouse button.
2. The shelf level “Chassis View” display appears as shown in Figure 766-1, displaying all of the cards in the shelf. Select the optical card desired by double clicking on it using the left mouse button.
3. The respective card display appears with the status and configuration information displayed similar to the one shown in Figure 766-2. If the 155 CRS card was selected, you must now select which port to run the diagnostics on. This can be accomplished by single clicking on the Port number 1 or 2 shown on the simulated faceplate at the left of the window. The screen should display Port 1 selected by default.
4. Select the *Diagnosics* button at the bottom of the window.
5. The Bit Interleave Parity window appears as shown in Figure 766-3. Select the Section, Line, or Path button according to where the BIP errors will be manifested. Using the left mouse button, select also the up or down arrows at the BIP Command Duration box to specify the duration of the BIP errors. Times specified are in seconds.
6. Select the *Apply* button to start the BIP error insertion into the overhead. Select the *Stop* button to stop the BIP error insertion, if desired, before the BIP Command Duration time has expired. The *Card View* button will redisplay the card view window and the *Close* button will close the Bit Interleave Parity window.

**Stop! You have completed this procedure.**

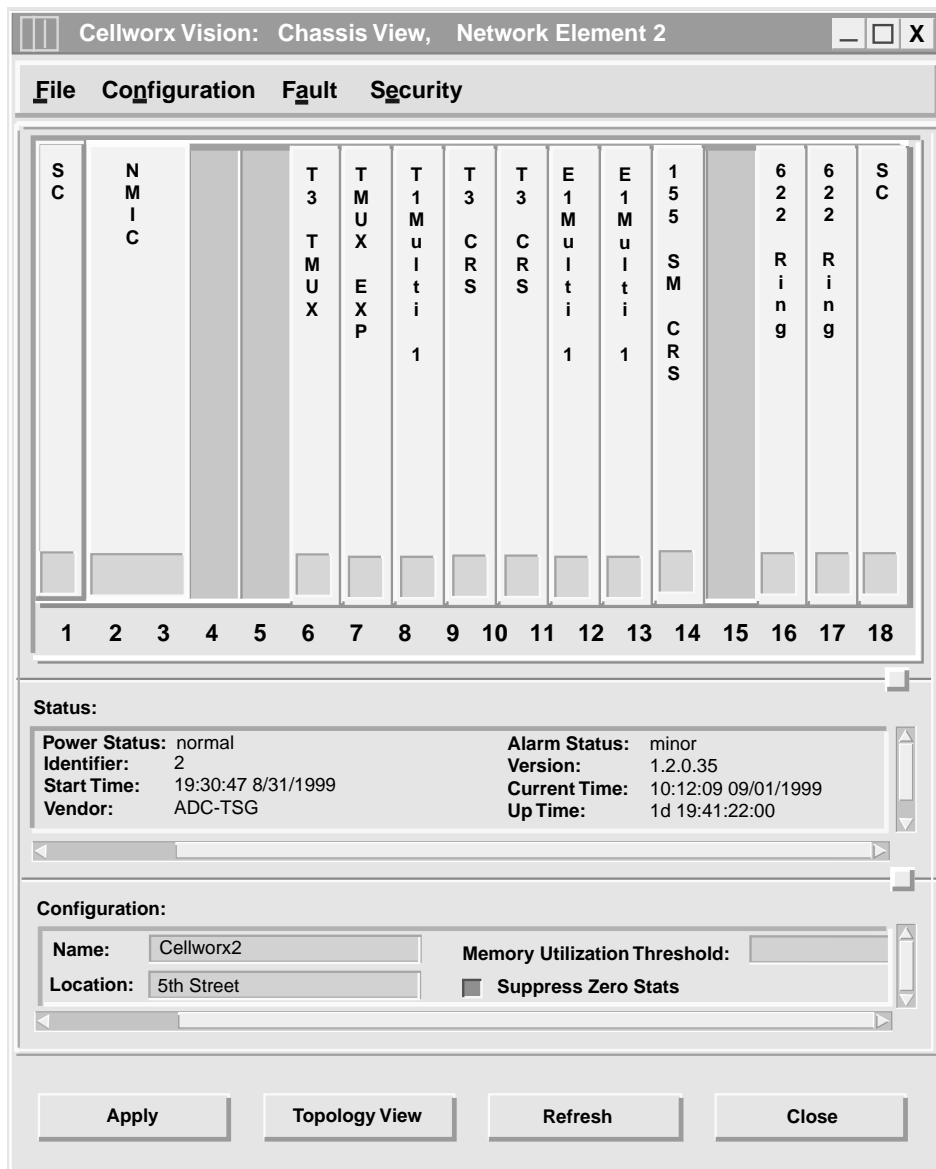

13455-B

Figure 766-1. Shelf Level GUI Chassis View Display

DLP-766  
Page 3 of 3

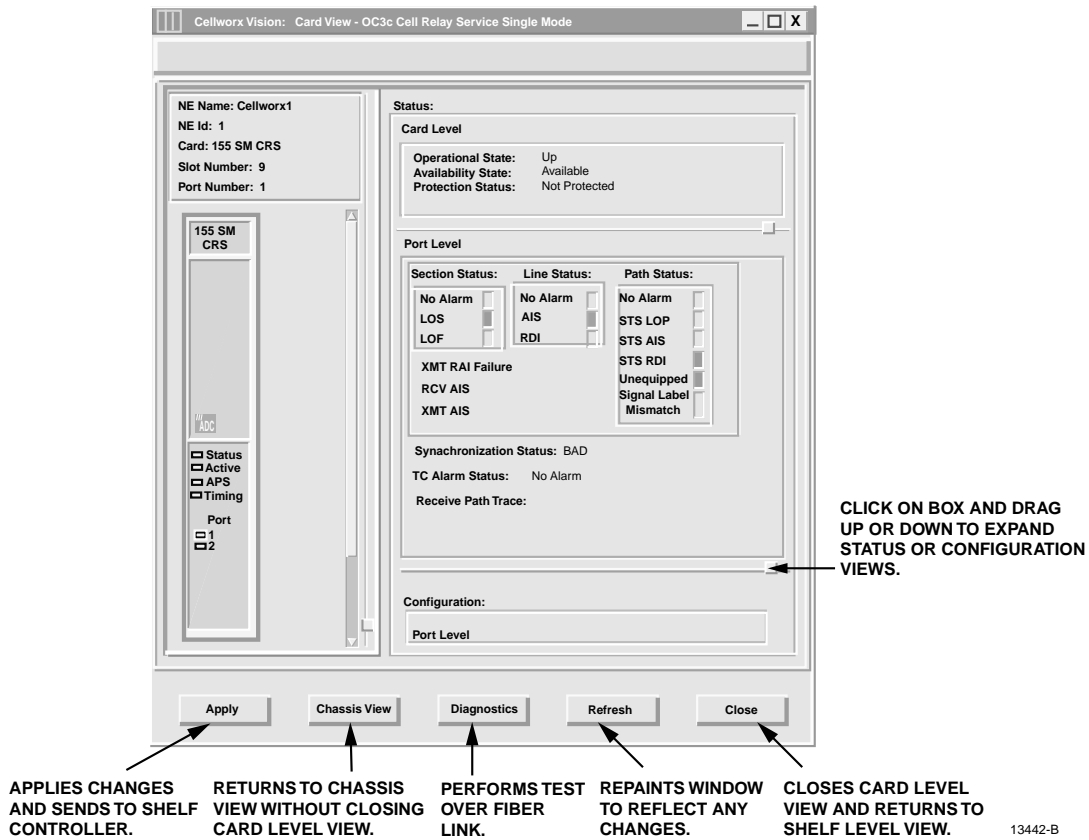

Figure 766-2. 155 SM CRS Card View Window

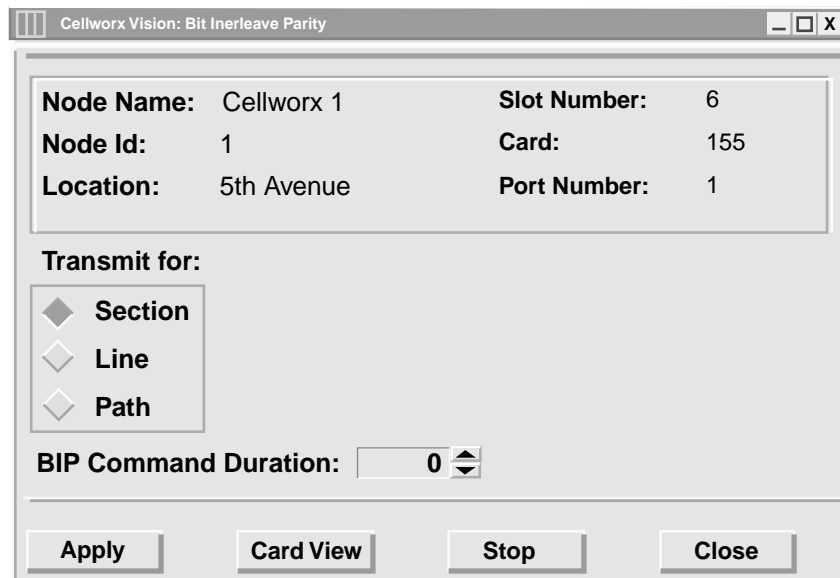

Figure 766-3. Bit Interleave Parity Error Diagnostics Window



## SET SYSTEM IDENTIFIER

**Summary:** This procedure defines the steps required to set a system identifier for each node. The system ID will help differentiate between the nodes displayed on the system GUI main screen. Setting the system ID does not affect the communications of the network in any way. The ID will also be displayed at the top of each GUI window and/or craft screen. The ID given to each node should be unique in order for the user to discern between them when viewing the GUI.

It is assumed that the user has gained access to the Cellworx STN system, has launched the GUI, and performed a discovery of each node before attempting this procedure.

1. From the GUI main display, select the node desired by double clicking on it using the left mouse button.
2. The shelf level “Chassis View” display appears as shown in Figure 767-1, displaying all of the cards in the shelf. The bottom section of the window has fields that the user can set under **Configuration**. Enter a unique name for the node and a location according to network planning.
3. Memory utilization threshold is a way to monitor the consumption of memory on the NMIC. If the field is set and the value reached, an informational alarm will be generated. Set the memory utilization by entering a value between 1 and 100 percent.
4. As performance-monitoring statistics are collected on each interface, the counts may be all zeros. By enabling the “suppress zero stats” option, the PM file with all zeros is not forwarded to the NMIC. This allows for less use of the management traffic bandwidth. Select the “Suppress Zero Stats” box to stop the shelf controller from reporting any historical data statistics that have a value of “0”.
5. Hit the **Apply** button to send the changes to the database.
5. Select the **Close** button to return to the topology view.

**Stop! You have completed this procedure.**

DLP-767  
Page 2 of 2

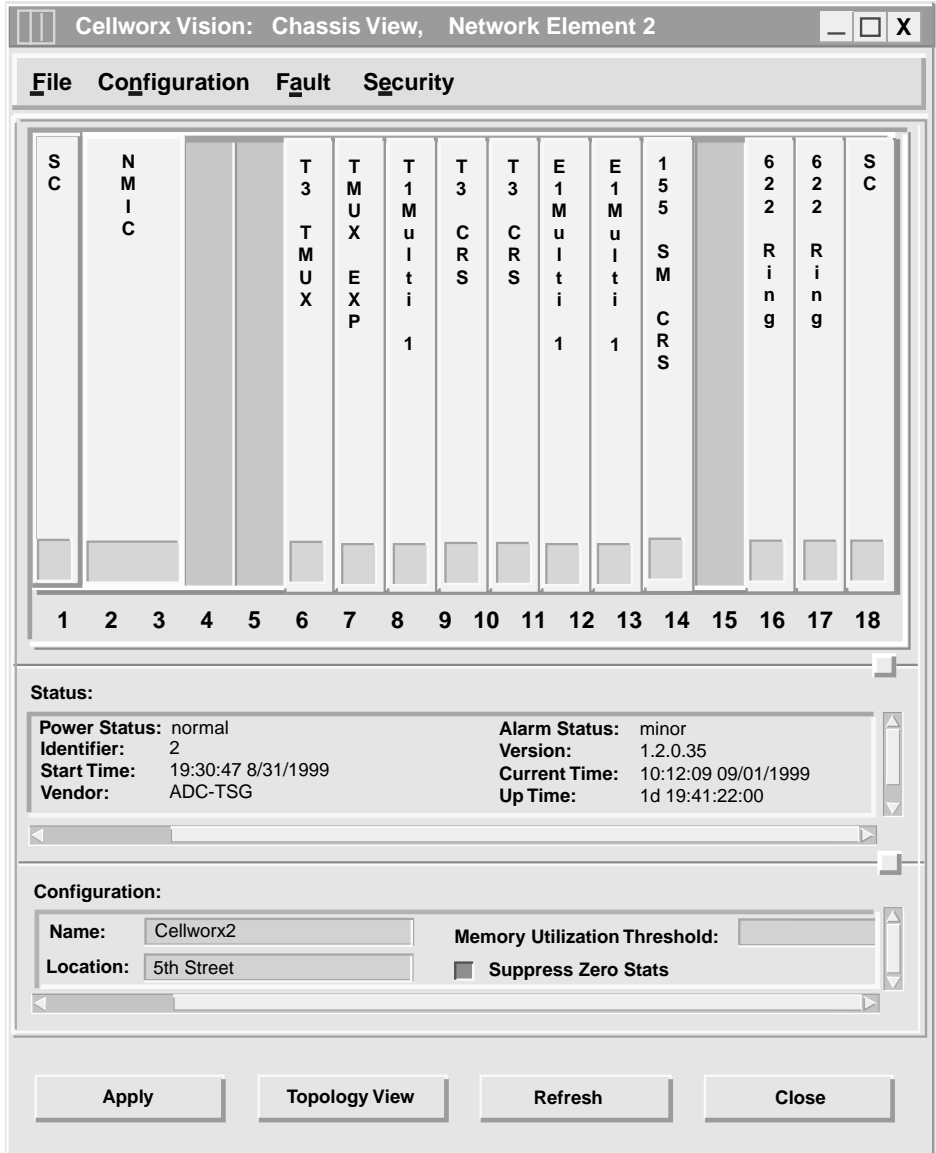

13455-B

Figure 767-1. Cellworx Vision Chassis View

## SET CRAFT USER CONFIGURATION

**Summary:** This procedure describes the steps required to successfully add, delete, or modify user access to the Cellworx STN shelf. The user account specifies the name, password, and access level for the system software which defines what the user can or cannot do while logged into the shelf. The user account is only active on the shelf it is created on, so it must be duplicated for each node within the network if the user is to have access to the entire network. The administrator whom assigns the users must have the highest level of access, which is a level 3 user, to enable administrative duties. Only one administrator should have access to this level at a time. It is assumed that the Administrator has already gained access to the system and has launched the Cellworx Vision GUI interface.

1. From the GUI main display, select the node desired by double clicking on it using the left mouse button.
  2. The shelf level “Chassis View” display appears as shown in Figure 768-1.
  3. Select the *Security* pull down menu by clicking on it using the left mouse button.
  4. Select the *Craft User Configuration* option by clicking on it using the left mouse button.
  5. The Craft User Configuration window appears as shown in Figure 768-2. Use the *up and down arrow* to toggle the user ID field from 1 to 25, selecting the ID number to be assigned to a user on this node.
- **Note:** Up to 25 users may be assigned per node but only one may be active on a node at a time.
6. At the *User Name* field, enter a unique name for the user being assigned. Up to 10 alphanumeric characters may be used.
  7. At the *Password* field, enter a unique password assigned to the user entered above, *using at least 6 and up to 10 characters with at least one character being a numeric value and one being a special character (dot, dash, etc.)*.
  8. At the *Password Verify* field, re-enter the password to confirm the password chosen. If the password is not entered exactly as it was above, the system will not create the user account.
  9. At the *Days Remaining for Account* field, enter the number of days the account will be allowed to be active. The administrator may wish to re-establish the accounts on a yearly basis for full time users, or create a temporary account for a few days or a week for a maintenance person to have temporary access. The accounts can be activated up to 999 days or left at 0 so the account will never expire.
  10. At the *Privilege Level* field, select the Level number, from one to three, that corresponds to the level of access the user may have. The levels are defined in Table 768-1.

**DLP-768**

Page 2 of 3

11. Select the *Apply* button to send the new information to the database.
12. Repeat this procedure for each user at each node as needed.
13. To delete a user from the database, enter the user name and password and verify password. Now select the *Delete* button to remove them from the system database. This must be done at each node the user is to be removed from if applicable. The last super-user with a lifetime expiration cannot be deleted.

**Stop! You have completed this procedure.**

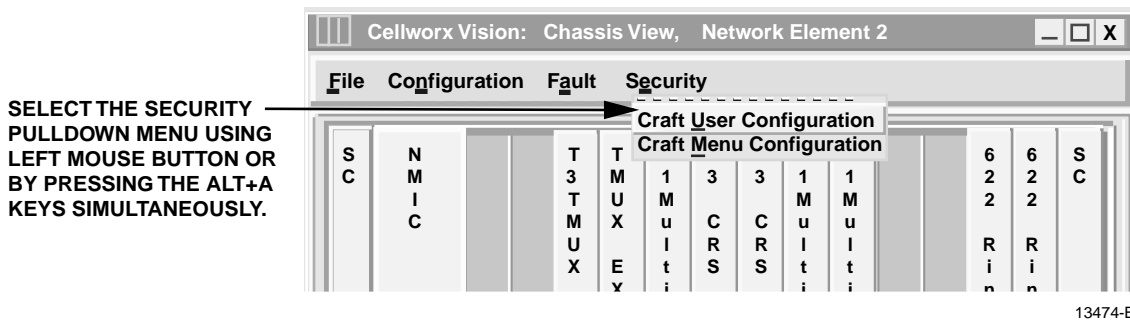

Figure 768-1. Cellworx Vision Security Menu Display



Figure 768-2. Cellworx Vision Craft User Configuration Display

Table 768-1. User Account Privilege Levels

PRIVILEGE LEVEL	PRIVILEGE PROVIDED
1	Lowest level of access. User is allowed to perform displays, alarm cut-off (ACO), or diagnostics on down facilities. No access to system configurations, card configurations, protection switching, or administrative duties (i.e., assigning user accounts, passwords, and security logs.).
2	User is allowed to perform all functions except administrative duties.
3	Highest level of access. User is allowed access to any screens and may perform any functions including administrative duties.

**DLP-769**

Page 1 of 2

**SET CRAFT MENU CONFIGURATION**

**Summary:** This procedure describes the steps involved to assign the minimal craft user levels required to access each craft menu. The craft “display” screens should be made available to all users (Level 1 and above). Any screens that allow configuration changes to cards, ports, or features, should be at least a Level 2. Level 2 users will not have access to the user accounts. The administrator Level 3 user will have access to all menus including user accounts. It is assumed that the user has gained access to the system and launched the Cellworx Vision GUI prior to this procedure. This feature has been disabled for release 2.0 systems.

1. From the GUI main display, select the node desired by double clicking on it using the left mouse button
2. The shelf level “Chassis View” display appears as shown in Figure 769-1.
3. Select the *Security* pull down menu by clicking on it using the left mouse button.
4. Select the *Craft Menu Configuration* option by clicking on it using the left mouse button.
5. The Craft Menu Configuration window appears as shown in Figure 769-2. Select a menu title on the left and then a User Level on the right. Any display screens should be set at a level 1 so all users can retrieve this information. Configuration screens should be set to level 2 so all level 2 users can configure the cards in a shelf. System administration screens should be set to level 3 so the level three administrator can do level one and two tasks as well as assign new users.
6. After changing the privilege levels on the craft screens, select the *Apply* button to send the information to the system database followed by the *Close* button to return to the shelf level GUI screen.

**Stop! You have completed this procedure.**

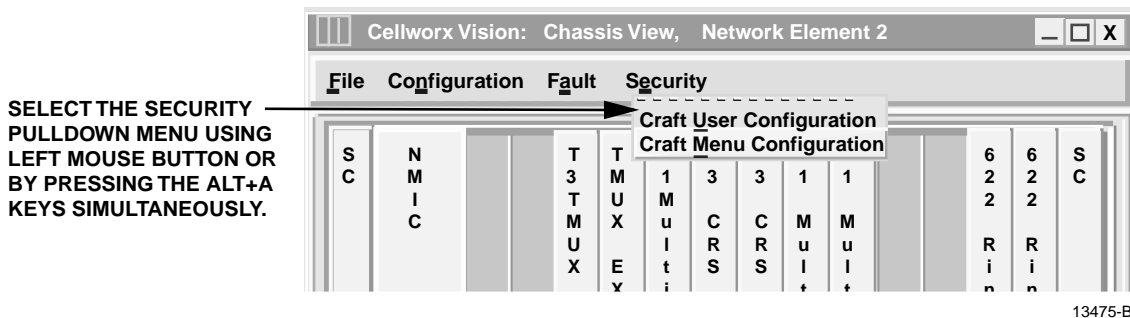
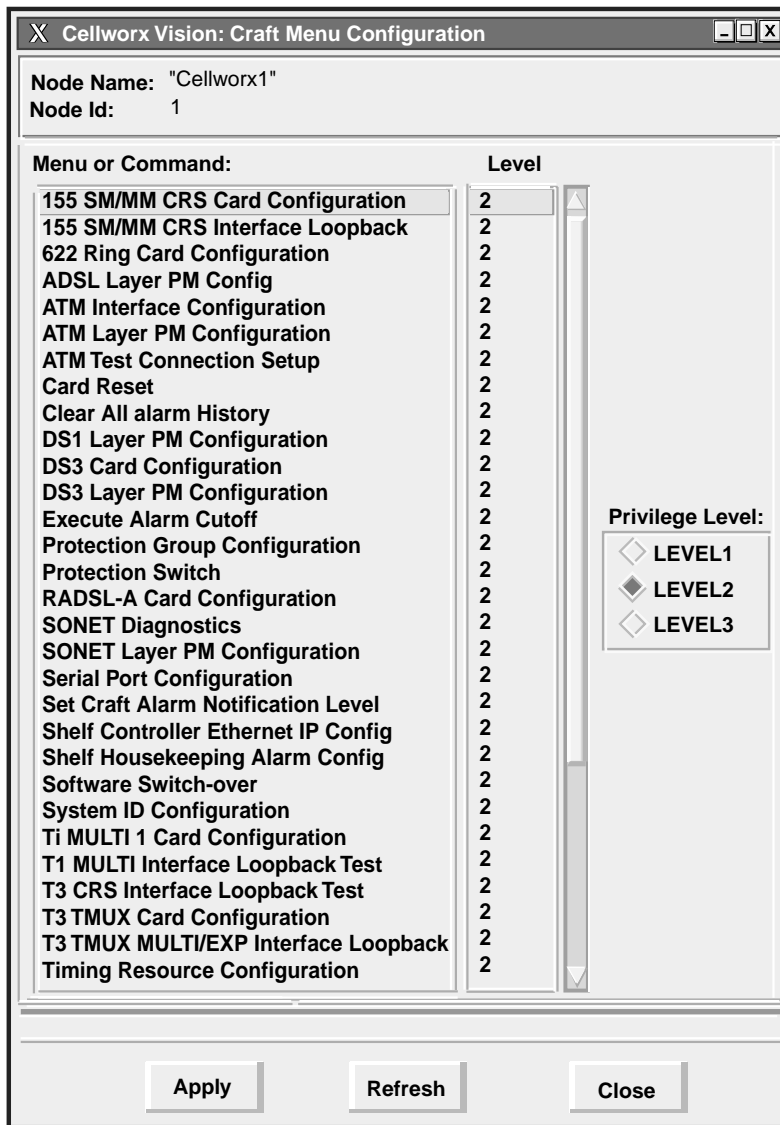

Figure 769-1. Cellworx Vision Chassis Level Display



13456-A

Figure 769-2. Craft Menu Configuration Display

## DLP-770

Page 1 of 2

## HARDWARE INVENTORY

**Summary:** This procedure instructs the operator in the steps required to display information for the cards residing in the Cellworx STN system. Inventory status information may be used for documenting card serial numbers and date of manufacture for warranty purposes, or obtaining part numbers for ordering spare cards.

It is assumed that the user has gained access to the system and has launched the Cellworx Vision GUI.

1. From the GUI main display, select the node desired by double clicking on it using the left mouse button.
2. The shelf level “Chassis View” display appears as shown in Figure 770-1. Select the **Configuration** pull down menu by clicking on Configuration using the left mouse button and then selecting the Hardware Inventory option. User can also obtain this screen using shortcut keys **Alt+N**, followed by **Alt+H**.
3. The Inventory status screen appears as shown in the example in Figure 770-2. Screen prints can be generated and kept in a system installation log for future reference. When replacement cards are ordered, these installation logs should be referred to, to ensure the same card types are ordered and correct serial numbers are sent back for warranty if applicable.
4. Select the **Close** button at the bottom of the window to return to the Chassis View screen.
5. Select the Topology View Button on the Chassis view screen to return to the GUI main window. Selecting the Close button will also return the user to the GUI main screen and close the Chassis View window.

**Stop! You have completed this procedure.**

SELECT THE CONFIGURATION  
PULLDOWN MENU USING LEFT  
MOUSE BUTTON OR BY PRESSING  
THE ALT+N KEYS SIMULTANEOUSLY.

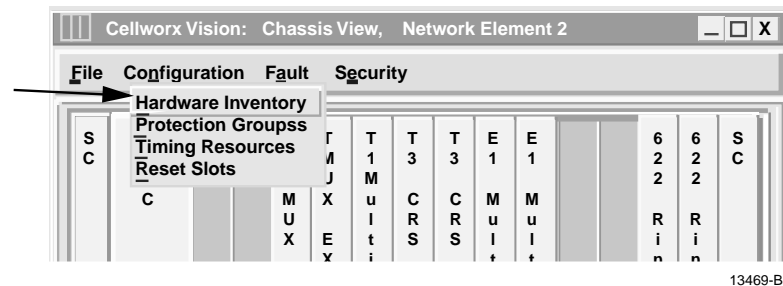

Figure 770-1. Chassis View Configuration Pull-down Menu



Cellworx Vision: Card Inventory

Node Name: "Cellworx 1"  
Node Id: 1

Slot	Card Type	Part Number	Serial Number	Catalog Number	Manufacturing Date
1	SC	ADC-part#	ADC-serial#	STN-ADC-xx-xxx-xx	9828
2	NMIC	ADC-part#	ADC-serial#	STN-ADC-xx-xxx-xx	9923
3					
4					
5					
6	T3 TMUX MULTI 1	ADC-part#	ADC-serial#	STN-ADC-xx-xxx-xx	9928
7	TMUX EXP	ADC-part#	ADC-serial#	STN-ADC-xx-xxx-xx	9945
8	T1 MULTI 1	ADC-part#	ADC-serial#	STN-ADC-xx-xxx-xx	9951
9	T3 CRS	ADC-part#	ADC-serial#	STN-ADC-xx-xxx-xx	9918
10	T3 CRS	ADC-part#	ADC-serial#	STN-ADC-xx-xxx-xx	0002
11	155 MM CRS	ADC-part#	ADC-serial#	STN-ADC-xx-xxx-xx	0012
12	155 MM CRS	ADC-part#	ADC-serial#	STN-ADC-xx-xxx-xx	0008
13					
14	155 SM CRS	ADC-part#	ADC-serial#	STN-ADC-xx-xxx-xx	9912

Refresh Close

13441-B

Figure 770-2. Hardware Inventory Display

**DLP-771**

Page 1 of 3

**INITIATE A PROTECTION SWITCH**

**Summary:** This procedure instructs the operator in the steps required to initiate a protection switch for the various interface types in the system that are equipped with a protection mechanism. The user may issue a Manual switch, Forced Switch, Lockout of protection, or Enable a card for switching. Frame Relay Service cards do not support a protection mechanism for Release 3.1 systems.

Prerequisites of issuing a switch request are:

- Card Admin Status must be UP.
  - Cards must be configured in a protection group.
  - Card APS Status must be Enabled.
  - Card Protection Group must indicate a protecting card that meets the previous criteria.
  - Both the working and protection card must have the same software and configuration data so the same level of service may be provided if a switch occurs.
  - User must have launched the Graphical User Interface and accessed the shelf level GUI before attempting this procedure. Refer to DLP-705.
1. From the GUI main screen, select the node that will have the protection switch performed on it by double clicking on it using the left mouse button. The shelf level GUI “Chassis View” window will appear.
  2. Select the **Configuration** pull down menu on the toolbar by clicking on it using the left mouse button, or by hitting the **Alt+N** keys on the keyboard. Refer to Figure 771-1.
  3. Select **Protection Groups** by clicking on it using the left mouse button or by hitting **Alt+P** on the keyboard.
  4. When the Protection Groups/Protection Switch window appears select the **Protection Switch** box at the upper left side of the window.
  5. Select the card to be switched using the left mouse button. Refer to Table 771-1 for valid protection group configurations.
  6. Select the protection switch type (Lock out, Manual, etc.) Refer to Table 771-2 for protection switch definitions.
  7. Select the **Apply** button at the bottom of the window to send the switch request.
  8. To release the switch, select the working or protect card and select the **Enable Auto Switch** followed by the **Apply** button.

**Stop! You have completed this procedure.**



## DLP-771

Page 3 of 3

Table 771-1. Card Protection Schemes

CARD TYPE	PROTECTION SCHEME	REQUIREMENTS
NMIC	1:1	Cards required at Gateway Node installed in adjacent slots. Working card in slots 2 and 3, protect card in slots 4 and 5. Shelf may operate with a minimum of one card but redundancy is recommended.
SC	1:1	Cards required in all Cellworx STN shelves, working in slot 1, protect in slot 18. Shelf may operate with a minimum of one card but redundancy is recommended.
622 Ring Card	N/A	All ring nodes must have cards installed in slots 16 and 17. Optical paths redundant though RICs.
155 CRS	1+1	Cards must be installed in any adjacent AIC slots. Dual port cards support two separate interfaces.
T3 CRS	1:N (N ≤ 3)	Three ports per card will switch to protect with a single port failure. One group of contiguous slots across the backplane up to four total cards per group.
T3 TMUX Multi 1 / T3 EXP	1:N (N ≤ 1)	One set of cards can be protected by a second set, or a single T3 TMUX can be protected by a redundant T3 TMUX.
T1 Multi 1	1:N (N ≤ 8)	One group of contiguous slots across the backplane up to nine total cards per group.
E1 Multi 1	1:N (N ≤ 8)	One group of contiguous slots across the backplane up to nine total cards per group.

Table 771-2. Protection Switch Command Definitions

SELECTION	OPTIONS	DEFINITIONS
Command	Lock out Forced Switch Manual Switch Enable Auto Switch	Prevents card from switching to protect. Force card to go to protection even if path is not reliable or available. A manual request to switch to or from protection, depending on card selected, will take effect if no other cards are switched to protect and if path is good. If card is part of a protection mechanism and a switch is activated, enabling the card will allow the revertive switch to take place after specified time period.

## LOOPBACK TEST

**Summary:** This procedure instructs the operator in the steps required to perform loopback test for the various interface types in the system. Loopbacks can be used to isolate network problems or confirm continuity to customer equipment. A loopback will remain active if the user logs out of the shelf.

1. From the GUI main screen, select the node that will have the loopback performed on it by double clicking on it using the left mouse button. The shelf level GUI “Chassis View” window appears similar to the one shown in Figure 772-1.
2. Select the card that will have the loopback performed on it by double clicking on it using the left mouse button. The card level display will appear whether it is a 622 RIC, 155 SM/MM CRS, T3 CRS, etc. Refer to Figure 772-2 for an example.
3. Select a port to loopback if applicable.
4. Select the **Loopback** type of loopback to be performed using the radio buttons shown in the window (None, Terminal, Facility, and/or Payload). Refer to Table 772-1 for definitions of the loopback options for each card type. Figure 772-3 shows loopback signal configurations.
5. Select the **Apply** button at the bottom of the screen to initiate the loopback.
6. Select the **None** option and **Apply** again to release the loopback.

**Stop! You have completed this procedure.**

DLP-772  
Page 2 of 4

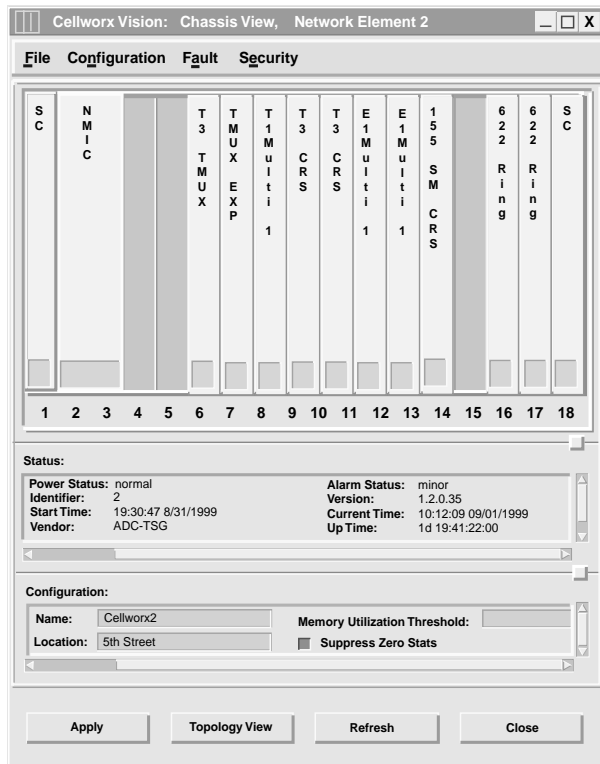

Figure 772-1. Cellworx Vision Chassis View

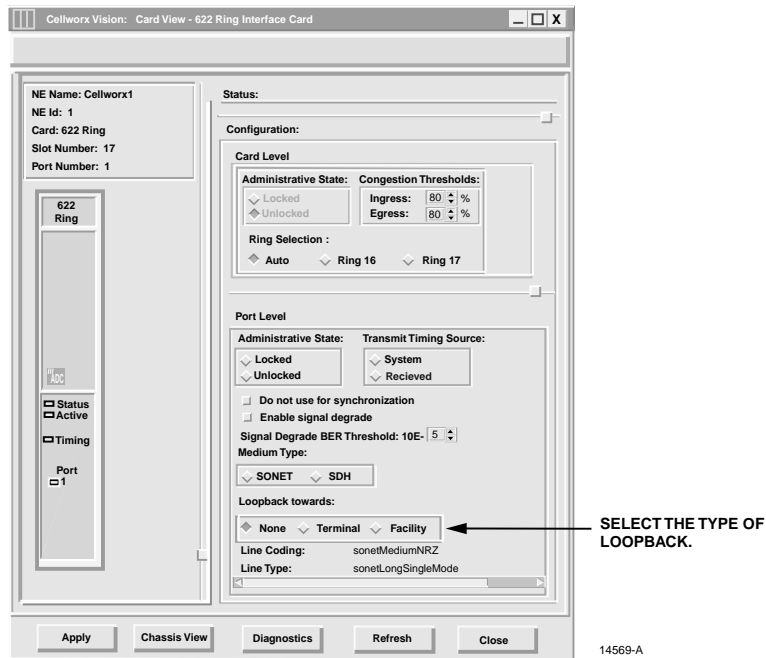
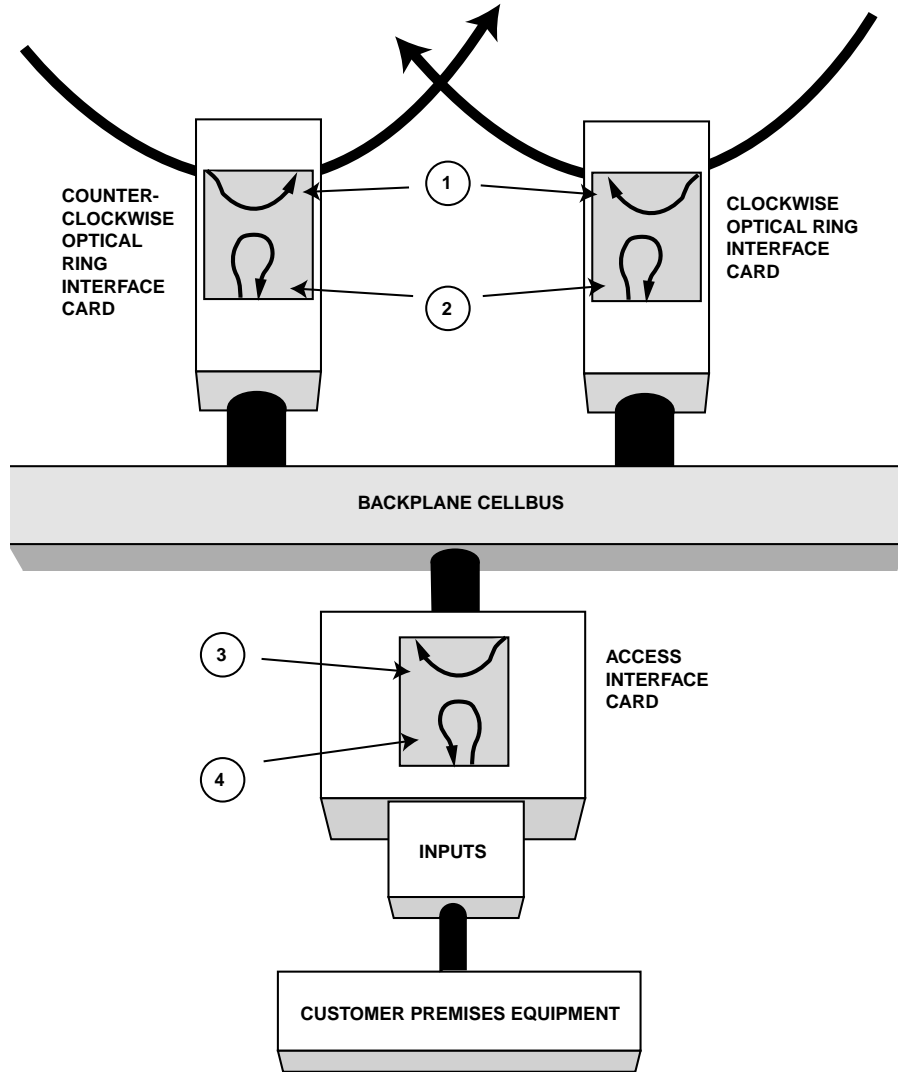

Figure 772-2. 622 RIC Card Configuration View

Table 772-1. Loopback Screen Options

PARAMETER	OPTIONS	DEFINITION
Port	1 for the 155,622, or 2488 RIC 1 or 2 for 155 CRS 1 to 3 for T3 CRS 1 to 16 for T1 or E1 Multi 1 1 DS3 port on a T3 TMUX 1 to 28 for T1 Ports between the T3 TMUX and TMUX EXP cards.	Selects the port that will have the loopback activated on it.
Loopback Test (155)	None Facility  Terminal	No loopback activated on this card. Sends cells back to the cellbus and back out to the ring. No changes are made to the path layer data. Loops the incoming signal back to the CPE and generates AIS to the cellbus.
Local Loopback (T3, T1, E1)	None Facility  Terminal  Payload	No loopback activated on this card. Sends cells back to the cellbus and back out to the ring. No changes are made to the path layer data. Loops the incoming signal back to the CPE and generates AIS to the cellbus. Loops the signal back to the CPE AFTER framing is performed and before being converted to ATM cells.
Far End Loopback (T3, T1, E1)	Send No Code Send Line Code Send Reset Code	

DLP-772  
Page 4 of 4



1. LOOPBACK TOWARDS FACILITY ON AN OPTICAL CARD LOOPS INCOMING SIGNAL BACK OUT THE TRANSMITTING SOURCE. NO CHANGES ARE MADE TO THE INCOMING SIGNAL SECTION OR LINE DATA
2. OC12C CRS LOOPBACK TOWARDS THE TERMINAL LOOPS CELLS BACK TO THE CELLBUS.
3. LOOPBACK TOWARDS TERMINAL ON AN AIC SENDS CELLS BACK TO CELLBUS AND BACK OUT TO THE RING, NO CHANGES ARE MADE TO THE PATH LAYER DATA.
4. LOOPBACK TOWARDS FACILITY ON AN AIC CARD LOOPS THE INCOMING SIGNAL FROM CPE EQUIPMENT BACK TO THE CPE EQUIPMENT. AIC GENERATES AIS TO CELLBUS. A DS3 "PAYLOAD LOOPBACK" LOOPS THE SIGNAL BACK TOWARDS THE FACILITY AFTER FRAMING IS PERFORMED AND BEFORE BEING CONVERTED TO ATM.

11729-D

Figure 772-3. Loopback Direction and Signal Flow Diagram





DLP-773  
Page 2 of 3

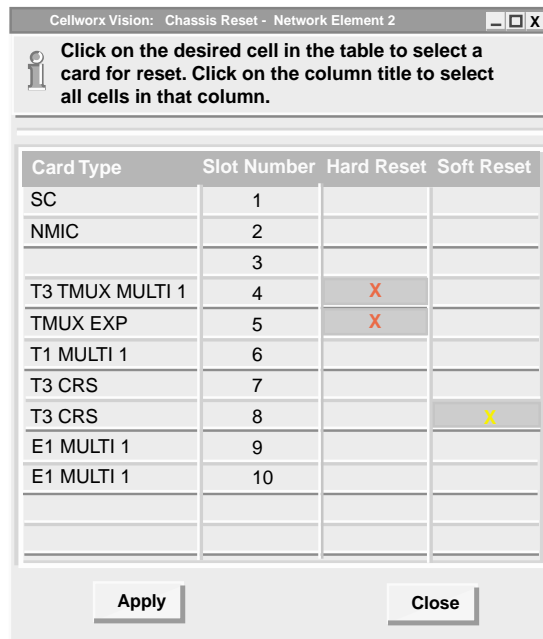

13479-B

Figure 773-2. Card Reset Display

Table 773 -1. Card Reset Level Definitions

Reset Level	SOFTWARE	CONFIG	HARDWARE / NE TEST	PERFORMANCE MONITORING	DEFINITION
Hard	Reset	Unaffected	Reset	Reset	Resets and tests all hardware, executes new card software download, cleans up temporary memory and affects traffic.
Soft	Unaffected	Unaffected	Unaffected	Unaffected	Cleans up temporary memory, initializes card software, will not affect traffic.
No	Unaffected	Unaffected	Unaffected	Unaffected	No changes to card or shelf.

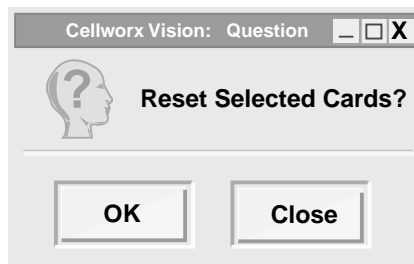

13478-A

Figure 773-3. Card Reset Question

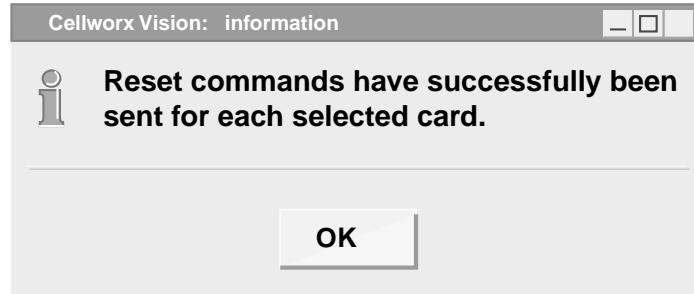

13460-A

Figure 773-4. Card Reset Confirmation Message

**DLP-774**

Page 1 of 4

**FINDING AND CHANGING THE NMIC IP ADDRESS**

**Summary:** This procedure defines the steps required to find and change the IP address stored on the Network Management Interface Card (NMIC). To help in the navigation of the unix shell, here are some general commands that the user may need.

Some vi commands:

- :help – use arrows to navigate
- :q – quit
- :sh – Opens shell in vi 9
- Up arrow – scrolls through recalled commands
- Delete key – exits without saving to start over, NEVER use backspace!!!

1. The first NMIC should be resting (not plugged into the backplane) in slot 2 and 3. Connect the RS232 DB9 serial port cable from the PC into the craft port on the NMIC in slot 2.
2. Start up the terminal emulation software. Insert the NMIC into the back plane (slot 2 NMIC only). The NMIC will start the boot process and will echo line after line of data to the terminal window.

◆ **Note:** The terminal emulator (ProComm Plus or HyperTerminal) needs to be set up using 9600bps, 8bits, 1stop bit and no parity.

3. The NMIC boot process quickly flashes by. And finishes at the Login: prompt. Log into the NMIC. From the factory the user id is root with NO password set. If the NMIC has been set up previously and you do not know the name and password, see your system administrator.
4. After logging into the NMIC either a bash# prompt will appear or you will be asked to configure the IP network. If left at the bash# then GOTO STEP 5. If asked to configure the IP network answer NO and continue with step 5.

**SHUTTING DOWN THE NMIC**

The commands listed in Table-774-1 can be entered at the NMIC PROMPT> to shut it down and must be all lower case. Refer to the commands listed in the description column for the one applicable to your NMIC state.

5. Type command 4 from Table 774-1 at the bash# prompt before the NMIC has completed the PSM process (green active and status LEDs, approximately 3 minutes).

Table 774-1. NMIC Shut Down Commands

	COMMAND	DESCRIPTION
1	/usr/bin/killall psm	Stops processes running on NMIC. If NMIC is fully operational than use this command. An operational NMIC can be identified by the two green LEDs, Status and Active.
2	/usr/bin/shutdown -r now	Shuts down NMIC and reinitializes it.
3	init 6	Shuts down NMIC and reinitializes it.
4	/usr/bin/killall -9 psm	As NMIC is rebooting you have 30 to 90 seconds to stop the process using this command. Reboot is indicated by a single amber/green LED.

6. Type the following command to set the window size of your display followed by an Enter.
  - bash# export TERM=vt100
7. Look for pre-existing databases in the /cellworx/config directory. You will be looking for files that match the following criteria: NMIC and or NE.1. Type the following command:
  - bash# /bin/ls /cellworx/config [enter]
8. If the files NMIC and or NE.1 do not exist, **GOTO STEP 10**, otherwise continue.
9. Remove the NMIC and or NE.1 files using the following command.
  - bash# rm /cellworx/config/NMIC [enter] y to acknowledge.
  - bash# rm /cellworx/config/NE.? [enter] y to acknowledge.
10. Look in the /etc/hosts file for IP addresses and names after the custom definitions at the end of the file.

```
bash# /usr/bin/tail /etc/hosts [enter]
```

The file should look like this: also NO entries after the last line of hash marks.

```
#####
#
#   End of Cellwox Custom Network Definitions   #
#
#####
```

11. If there are NO lines after the last line of hash marks then **GOTO STEP 14**

**DLP-774**

Page 3 of 4

► **Note:** The UNIX command, `/usr/bin/tail` will display the last 10 lines of the specified file.

12. Delete all the lines after the last hash lines (all lines after line 111) in the `/etc/hosts` file.

```
bash# /bin/vi /etc/hosts [enter]
```

13. Type the following commands in the vi editor:

```
[shift] g(this will take you to the end of the file)
```

```
dd          (this will delete the line the cursor is on), continue till the cursor ends up
             on the last line of hash marks.
```

```
[esc][esc]ZZ (these three command will save the file and exit the vi editor)
```

**CONFIGURING THE NMIC IP ADDRESS**

14. Once the log-on process is completed, the commands listed in Table 774-2 should be entered in the sequence shown to properly set up the display.

Table 774-2. PC/Laptop Display Parameters

COMMAND	DESCRIPTION
<code>export TERM=vt100</code>	If working from pc/laptop it is good to use following command.
<code>tail /etc/hosts</code>	The command displays the last ten lines of the file when looking for additional information below the hash-marked box.
<code>vi /etc/hosts</code>	This command takes you into an edit mode of this file.
<b>Shift+G (keystroke)</b>	Brings cursor to end of file. Any additional information below the hash-marked box, past line 110, needs to be deleted.
<code>dd</code>	Deletes the line the cursor is on.
<b>Escape key (Esc)</b>	When hit multiple times, it causes the system to exit the file/complete mode.
<code>ZZ</code>	Saves and exits.
<code>/sbin/.cw/cw_netcfg</code>	Reconfigures NMIC.
CONFIGURING A SECOND NMIC (STAND-BY)	
<code>shutdown -h now</code>	Shuts down NMIC and halts reinitialization while the second NMIC is being configured if needed.
<code>init 0</code>	Shuts down NMIC and halts reinitialization
CONFIGURING A SINGLE NMIC	
<code>shutdown -r now</code> -or- <code>init 6</code>	Either of these commands will shut down the NMIC and reinitialize it.

**TELNET TO THE NMIC**

15. At this point it is necessary to telnet back to the NMIC after it reboots. Following the log in process, the Run command for your particular application will initialize the configuration of the NMIC system files. The commands listed in Table 747-3 can be entered in the sequence shown from the UNIX PROMPT.

Table 774-3. Telnet and Configuration Initialization

COMMAND	DEFINITION
Telnet (name given NMIC)	Following the telnet command, enter the actual name given to the NMIC.
Export TERM=vt100	If working from pc/laptop, enter this command.
Export DISPLAY=(IP address)	IP address is of machine you are working from.
Start, Run, winipcfg -or- ipconfig -or- /sbin/ifconfig -a -or- /usr/sbin/ifconfig -a	For Windows 95 and 98, this will start the configuration.  To find in Windows NT go to DOS prompt and enter command.  To find in a Linux operating system, enter this command.  To find in a Solaris operating system, enter this command.

16. Look for Ethernet Zero address: INET address plus:0+0
17. Enter the following command to launch the Cellworx Vision Graphical User Interface:
- “CellworxVision”
18. Follow GUI

**Stop! You have completed this procedure.**

**DLP-775**

Page 1 of 3

**ADD OR CHANGE AN SNMP TRAP HOST ON THE NMIC**

**Summary:** The following procedure describes the steps required to add or change SNMP trap hosts on the Cellworx STN NMICs. A trap host is the system or network IP configured to receive traps that are initiated by the Cellworx STN system. The trap messages may be used to track problems with the system or stored for statistical data. The file to be changed is *config.snmp.active* and is located in the */cellworx/config* directory. To help in the navigation of the unix shell, here are some general commands that the user may need. The user should have some UNIX experience before accessing or modifying these files.

Some vi commands:

- `:help` – use arrows to navigate
- `:q` – quit
- `:sh` – Opens shell in vi 9
- Up arrow – scrolls through recalled commands
- Delete key – exits without saving to start over, NEVER use backspace!!!

1. Telnet to the NMIC and at the NMIC command line, type in the following command:
  - `# export TERM=vt100`
  - `# vi /cellworx/config/config.snmp.active`
2. Figure 775-1 shows an example of an unedited NMIC file that should be displayed. Notice the last MANAGER line shows only a localhost as the recipient of the traps.
3. There are two lines that need to be added to the file. In the example shown in Figure 775-2, we have added an SNMP Trap host of 192.168.10.90. To do this, use the **Down Arrow** keys to move the cursor to the last line starting with “MANAGER”.
4. With the cursor at the beginning of the line enter “**y3y**”. This will “yank” three lines to the clip board.
5. Use the **Down Arrow** keys to step down one line and enter a “p” to paste the two lines into the file.
6. An exact duplicate of the MANAGER localhost lines are now displayed. Use the **Arrow keys** to move the cursor to the second MANAGER localhost line and position the cursor just before localhost.
7. Enter a **Shift+C** and begin typing the new SNMP Trap host IP address. Typing will overwrite the localhost if the Shift+C keys were entered correctly.
8. After correctly entering the IP address, hit **Esc** to leave the insert mode.



9. The file: /cellworx/config/config.snmp.active is READ-ONLY, so save the file in vi by entering the command string **:w!**
10. The vi will display a confirmation message that the file has been written. Exit vi by entering the command string **:q!**
11. Repeat this procedure starting at step 1 replacing /cellworx/config/config.snmp.active with the directory string **/cellworx/config/config.snmp.local**.
12. Once completed, perform this procedure on the stand-by NMIC also.

**Stop! You have completed this procedure.**

```
# WARNING :::  
#  
# Default agent configuration file. Please DON'T modify if you don't know  
# what you are doing because it can have adversed affect on the NMIC software.  
#  
# WARNING :::  
# !!! START USER CONFIGURABLE PARAMETERS.  
#  
# The following lines are the only one that may be configurable by the user.  
#  
# Each "MANAGER" clause define one destination. The syntax is as follows :  
# MANAGER    <host | IP address>  
#           SEND ALL TRAPS TO PORT <trap port on destination>  
#  
# Define the forwarding of the traps to the Cellworx GUI  
MANAGER    localhost  
           SEND ALL TRAPS TO PORT 10162  
# !!! END USER CONFIGURABLE PARAMETERS.  
# WARNING :::
```

Figure 775-1. Unmodified SNMP Trap Host File

**DLP-775**

Page 3 of 3

```
# WARNING :::  
#  
# Default agent configuration file. Please DONT modify if you don't know  
# what you are doing because it can have adverse affect on the NMIC software.  
#  
# WARNING :::  
# !!! START USER CONFIGURABLE PARAMETERS.  
#  
# The following lines are the only one that may be configurable by the user.  
#  
# Each "MANAGER" clause define one destination. The syntax is as follows :  
# MANAGER <host | IP address>  
#     SEND ALL TRAPS TO PORT <trap port on destination>  
#  
# Define the forwarding of the traps to the Cellworx GUI  
MANAGER    localhost  
           SEND ALL TRAPS TO PORT 10162  
MANAGER    192.168.10.90  
           SEND ALL TRAPS TO PORT 10162  
# !!! END USER CONFIGURABLE PARAMETERS.  
#WARNING :::
```

**Figure 775-2. Modified SNMP Trap Host File**

## ALARM CUT-OFF (ACO)

**Summary:** This procedure instructs the operator in the steps required to perform an alarm cut-off on a node in the Cellworx node. An alarm cut off disables the shelf audible alarm for any currently active alarm conditions. Any alarm conditions that are activated subsequently will reenact the audible alarm until the alarm conditions are cleared, or the operator reinitiates the ACO condition. An ACO will not extinguish any visual or message indications; visible indications shall be changed from unacknowledged (i.e., flashing) to acknowledged (constant).

The user must have gained access to the Cellworx Graphical User Interface (GUI) before performing this procedure.

1. From the GUI main screen, select the node that will have the ACO activated on it by double clicking on it using the left mouse button. The shelf level GUI “Chassis View” window appears similar to the one shown in Figure 776-1.
2. Select the Fault pull-down menu using the left mouse button or by entering *Alt+F*.
3. Select the *Execute Alarm Cut-Off* on the menu using the left mouse button or by entering *Alt+C*.
4. The system responds with a confirmation message as shown in Figure 776-2. Select OK to continue with the ACO or Cancel to abort the operation.

**Stop! You have completed this procedure.**

SELECT THE FAULT PULLDOWN MENU USING LEFT MOUSE BUTTON OR BY PRESSING THE ALT+A KEYS SIMULTANEOUSLY.

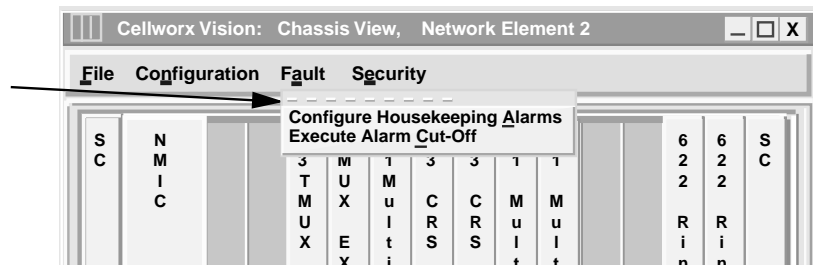

13473-C

Figure776-1. Shelf Level Alarm Cut-Off Window

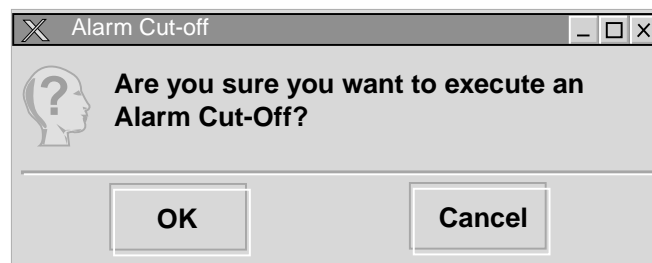

14572-A

Figure 776-2. Alarm Cut-Off Confirmation Window

## DLP-777

Page 1 of 3

### REMOVE AND/OR REPLACE CELLWORX CARDS

**Summary:** This procedure instructs the operator in the steps required to remove a defective AIC, SC, RIC, or EIM from the shelf and install a replacement card in its place. Before removing a card from the shelf, the user should verify there is no traffic on it by performing a switch over to the protect card if available.

1. Place the ESD wristband on your wrist and snap the ground wire to it. Plug the ground plug into the grounded ESD jack located at the upper right side of the STN shelf.
2. Locate the cards to be removed and their replacements.
3. To remove a card from the shelf, pry outward on the ejector ears using the thumbs. This will dislodge the card from the backplane and allow it to be withdrawn from the card guides. Refer to Figure 777-1 for an example of removing a card from the shelf. This can be applied to the front access or the rear access cards.
4. Using one hand to support the card underneath as it is drawn out, remove the card with the other hand.
5. Place the card in an Electro-statically protected bag and place in the proper packaging material in anticipation for its return to ADC Telecommunications for evaluation.
6. Align the replacement card with the card guides in the shelf at the proper slot position holding the card with the component side facing right. Refer to Figure 777-2.
7. Slide the card in until the ejector ears reach the card cage trough. Fully seat the card into the backplane by pressing the ejector ears toward the shelf until they rest against the faceplate or the printed circuit board for EIMs. Once seated, give the card a gentle push to ensure it makes good contact with the backplane.



**Warning:** Do not use excessive force. If excessive resistance is felt, remove the module, check for alignment and/or obstructions, and try seating it again. Take care not to bend any pins in the backplane.

8. After replacing the card, the user may perform some acceptance tests per NTP-011.

**Stop! You have completed this procedure.**

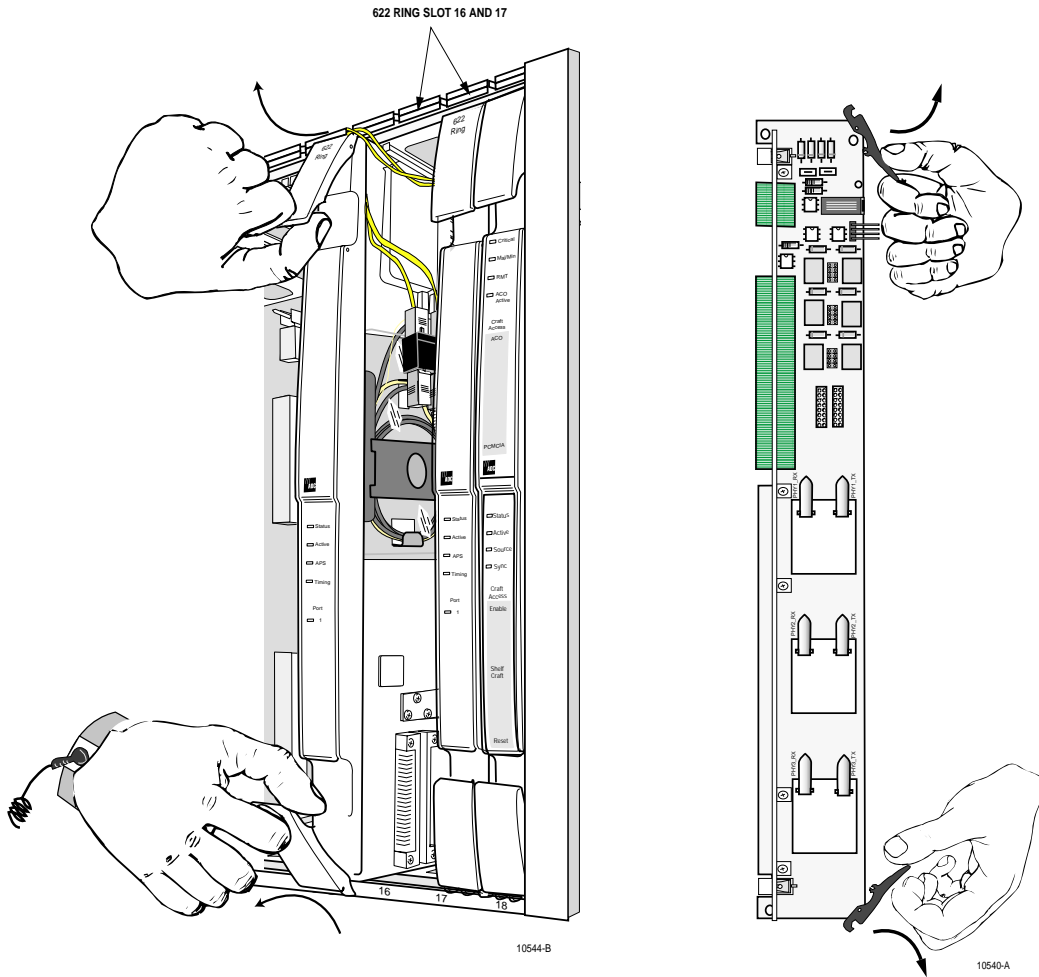

Figure 777-1. Removing a Front Access Card or EIM from the Shelf



## ENDING A GUI SESSION FOLLOWING AN ABNORMAL SESSION ENDING

**Summary:** This procedure will help the user log back onto the GUI system after an abnormal session ending. An abnormal session ending might have occurred by operator error, time out, or other unforeseen events. In this event, it might be necessary to free up the GUI and log back in. If the NMIC for some reason reboots and the GUI goes down, the user only needs to log in and start the GUI as usual.

If the session is ended because the machine that the GUI was exported to was rebooted/crashed, the GUI process may or may not shut down. If the GUI process still exists then:

1. Log onto the NMIC as the root user.
2. The administrator can display all GUI users that are currently logged onto the system by entering the following command at the root bash prompt exactly as shown:
  - `manageGui`
3. The system displays all active users one through five and indicates the “1<sup>st</sup> Privileged User” as shown in Figure 778-1. This is the first Level 3 user who logged onto the system and in doing such is the only one that can make topology changes and perform protection switches/restoration. If logged on as the root user, you have the privilege of “killing” the GUI sessions of other users at this point. The system prompts the administrator to type in the number of the user to boot off (numbers 1 to 5).

**Stop! You have completed this procedure.**

```
ADC LINUX for Cellworx (R)
Warning: Unauthorized use of this
system may lead to prosecution.
Login: root
Last login: Mon May 8 09:36:45 from 155.xxx.245.xxx

This is a list of GUIs currently active:::
GUI Id = 1: User = root DISPLAY=155.xxx.245.123:0.0 (1st Privileged User)
GUI Id = 2 is not currently active
GUI Id = 3 is not currently active
GUI Id = 4 is not currently active
GUI Id = 5 is not currently active
Please enter the GUI Id of the GUI to be terminated or -1 to exit : █
```

Figure 778-1. Terminal Display for Managing GUI

### RETRIEVE 2488 RIC STATUS

**Summary:** This procedure defines the information retrieved from the shelf level GUI card status display for the 2488 RIC card. User must have the GUI launched and accessed the shelf level GUI display per NTP-007 prior to performing this procedure.

1. Double click on the 2488 Ring card located in slot 16 in the shelf level GUI “Chassis View” at the top of the window.
2. The 2488 Ring card display appears as shown in Figure 779-1. Click the small block between the Status and Configuration sections and drag it downwards to view all the status information. Refer to Table 779-1 for definitions of status information provided.
3. Select the *Close* button to return to the shelf view.

**Stop! You have completed this procedure.**

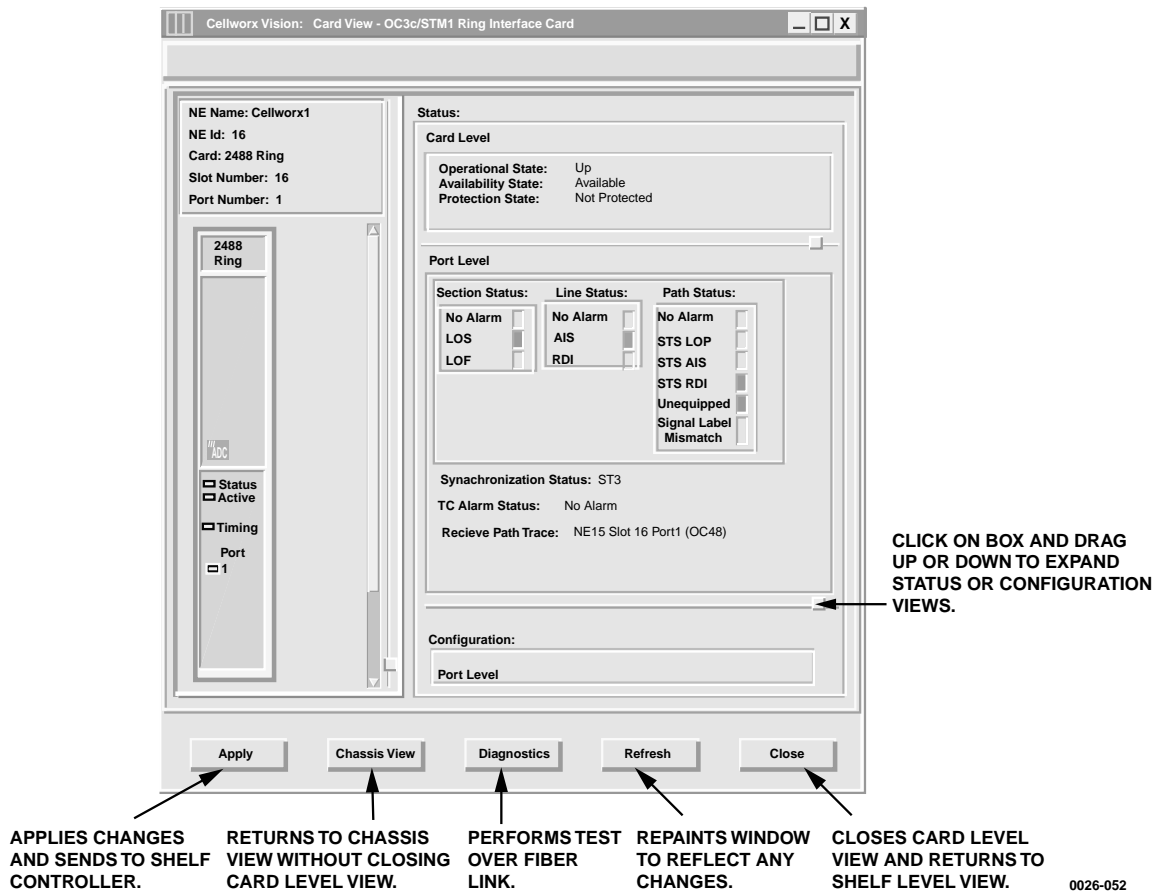

Figure 779-1. 2488 RIC Status Window



Table 779-1. 2488 RIC Card Status Definitions

ITEM	STATUS	DEFINITION	ACTION
<b>CARD</b>			
Operational State	Up	Card is functioning properly.	No action required.
	Down	Card is not functioning properly, is in reset mode, or failed. Check Admin state.	Verify card is installed, check for failure indications or provision card for service per DLP-756.
	Unknown	The system processor does not currently know the operational status.	Wait a few seconds for system to complete its operations and then update the screen.
Availability State	Available	Card is ready for processing commands.	No action required.
	In Test	Card is currently processing test signals.	Wait a few seconds for screen to update.
	Failed	Card has failed operation and system has placed it out of service.	Card may be performing a reset, or the bus may be busy.
	PowerOff	No power to the card.	Check power source. Replace card if source is good per DLP-777.
	Not Installed	Card is not installed.	If required, install card in selected slot per DLP-777 and provision per DLP-756.
	Offline	Card is installed and provisioned but currently off line.	If required, set module on line per DLP-756.
	Dependency	Card is supplying timing reference, traffic, or other data to the system.	Perform a soft switch over (manual) per DLP-771 to release card dependency if removing.
	Unknown	The system processor does not currently know the availability status.	Wait for processor to update current status, may need to perform a manual reset of SC per DLP-773.
<b>PORT</b>			
Section Status	No Alarm	No errors between local and next node.	No action required.
	LOS	Loss Of Signal, cannot locate section data.	Check connectors, fiber, and transmitter at other end.
	LOF	Loss Of Frame, cannot locate frame bit of section data.	Check signal type, and power level of received signal.
Line Status	No Alarm	Receiving good input signal	No action required.
	AIS	Alarm Indication Signal, inserted all 1s or blue signal at originating node.	Check signal status at traversing nodes, and low speed signal input at transmitting node.
	RDI	Remote Defect Indicator.	Problem at the far end.

(continued)

## DLP-779

Page 3 of 3

Table 779-1. 2488 RIC Status Definitions, continued

ITEM	STATUS	DEFINITION	ACTION
Path Status	No Alarm	Receiving good input signal.	No action required.
	STS LOP	STS signal Loss Of Pointer.	Check sync reference sources and input.
	STS AIS	STS Alarm Indication Signal.	Remote end transmitting AIS due to loss of payload for path.
	STS RDI	STS signal Remote Defect Indication.	Remote end informing local end it is receiving a defective signal.
	Unequipped Signal Label Mismatch	Unequipped time slot. Payload descriptor does not match overhead description.	This time slot is not being utilized. Check VP/VC connection for provisioning errors per DLP-704.
Sync Status (S1)	PRC	SDH Primary Reference Clock	Timing reference reliability levels. If sync status does not meet required level, check source and inputs. Provide the required clock source and change configuration settings for the card per DLP-749.
	PRS	Primary Reference Source	
	SEC	SDH Equipment Clock Traceable	
	SSU	SDH Sync Supply Unit	
	ST1	Traceable	
	STU	Stratum 1 level source	
	ST2	Synchronized Traceability	
	ST3	Unknown	
SMC	Stratum 2 level source	No action required.	
DUS	Stratum 3 level source SONET Minimum level Clock Reference cannot be used for source		
Received Path Trace (J1)	Card Dependent	Path trace is a 64-character string assigned to a path between nodes in either direction identifying the transmitting node using the following format: NE<id>_Slot<slot#>_Port1 (RIC)	No action required.

## 2.0 TO 3.0 SOFTWARE RELEASE UPGRADE PROCEDURE

**Summary:** This procedure details the steps required to upgrade the Release 2.0 system software to Release 3.0. The user should have access to an X-terminal or similar workstation device that will allow telnet sessions to the NMIC. The following items are prerequisites to this procedure:

- This procedure must be initiated with the slot 2 in the “Active” state.
- A Shelf Controller Card (SCC) must be present in slot 1 of every shelf. The SCC does not have to be active but if only one SCC is present in any shelf, it must be in slot 1.
- These UNIX based commands are case sensitive. Pay particular attention to the upper and lower cases shown in the examples when entering commands. All commands are written for a UNIX system. If the user is using a PC for the file transfers, appropriate changes should be made.
- If this Cellworx system has two NMICs, both NMICs should be in the system with EIMs in place and Ethernet connectivity provided to the workstation used for the upgrade.
- It is recommended that the user be familiar with all steps of the upgrade process before beginning.

### DELETE INCOMPLETE CONNECTIONS

The software upgrade procedure cannot be performed if the system has any incomplete connections. Before beginning, open the "Connection List" screen in the CellworxVision GUI and verify that for each connection type there are no incomplete connections. Verify this for VP-VP, VC-VC, CES-VC, and CES-CES connection types. If you do find any incomplete connections, then you must either delete them or complete them.

- ◆ **Note:** Failure to delete incomplete connections prior to attempting the software upgrade procedure can result in irreversible database corruption.

### PLACE SYSTEM INTO STEADY STATE

Verify the system is in steady state prior to proceeding with the software upgrade procedure, i.e., verify that for each protection group the working card is in the active state.

**DLP-780**

Page 2 of 10

**SAVE DATABASES**

**Summary:** The user should save all databases (NMIC and NE) from the slot 2 NMIC prior to initiating the software upgrade procedure. Note that this is a precautionary measure only since the databases are also backed up during the procedure itself. Should the NMIC disk become corrupted for some reason, however, it's best to have all databases saved to an external storage medium. The following steps explain how to do this:

1. Open a new shell window or physically connect a laptop or workstation to the NMIC and log into the slot\_2 NMIC as a root user. This shell will be referred to as the "slot\_2 NMIC shell".

```
telnet [IP address of slot_2 NMIC]
```

2. At the slot\_2 NMIC shell, change to the directory in which the databases are located by entering the following command:

```
cd /cellworx/config
```

3. Make a directory on the slot\_2 NMIC used to store the Release 1.2 databases during the upgrade by entering the following command:

```
mkdir release2.0_dbs
```

4. Copy the databases to the new directory by entering the following command:

```
cp NE.? NE.?? NMIC phase2.0_dbs
```

- **Note:** The question marks are single character wildcards. (**Do not delete the NE.default file.**)

**COPY DATABASES TO AN EXTERNAL DEVICE**

- **Note:** This next section is optional. Having the databases stored on an external device is an extra precaution.

5. Invoke a new shell (not a NMIC shell) on the laptop or workstation. This shell will be referred to as the "Workstation shell". From the Workstation shell, change to the root directory by entering the following command:

```
cd / or cd \ on a PC
```

6. Make a directory called "cellworx" on the external workstation by entering the following command:

```
mkdir cellworx
```

7. Within the cellworx directory on the external workstation, make another directory called release1.2\_dbs by entering the following command:

```
mkdir /cellworx/phase2.0_dbs
```

8. Change to the new directory by entering the following command:

```
cd /cellworx/phase2.0_dbs
```

9. From the Workstation shell, establish an FTP connection to the slot\_2 NMIC by entering the following command:

```
ftp [IP address of slot_2 NMIC]
```

10. Log into the NMIC as “cellworx” and enter the cellworx password. The default password is blank so the user may elect to press *Enter* or *Return* or enter the cellworx password set by the user followed by *Enter* or *Return*.

11. At the FTP prompt, set the binary file transfer mode by entering the following command:

```
bin
```

12. At the FTP prompt, change to the directory created earlier on the slot\_2 NMIC by entering the following command:

```
cd /cellworx/config/phase2.0_dbs
```

13. At the FTP prompt, retrieve (get) all the files in the current directory by entering the following command:

```
mget *
```

14. At the FTP prompt, exit the FTP session by entering the following command:

```
bye
```

## FTP SOFTWARE TO EACH NMIC

**Summary:** The software needed for upgrading each NMIC must be transferred from an external source (most likely a Cellworx CD), to each NMIC. Use the slot 2 NMIC shell from the previous steps to upgrade the slot 2 NMIC. Log into the slot 4 NMIC as the root user from a separate shell to upgrade the slot 4 NMIC.

- ◆ Note: Keep both NMIC shell windows open. They will be used throughout the upgrade process.

```
telnet [IP address of the slot 4 NMIC]
```

**DLP-780**

Page 4 of 10

15. In the slot\_2 NMIC shell, create a directory on the slot\_2 NMIC to store the Release 3.0 software. To do this, enter the following commands:

```
cd /tmp - changes to a temporary directory  
mkdir p3 - makes a directory called p3 under the /tmp directory  
chmod 777 p3 - adds write permissions to the /tmp/p2 directory
```

16. Open a new shell window and log into the slot\_4 NMIC as a root user. This shell will be referred to as the “slot\_4 NMIC shell”.

```
telnet [IP address of slot_4 NMIC]
```

- **Note:** Keep both NMIC shell windows open as they will be used throughout this upgrade process.

17. Create a directory on the slot\_4 NMIC to store the Release 3.0 software. In the slot\_4 NMIC shell type the following commands:

```
cd /tmp - changes to a temporary directory  
mkdir p3 - makes a directory called p3 under the tmp directory  
chmod 777 p3 - adds write permissions to the /tmp/p3 directory
```

18. From the Workstation shell, ftp the software from the Cellworx CD to the directory previously created for the software on the slot\_2 NMIC.

```
ftp [IP address of the slot_2 NMIC]  
bin - sets the binary file transfer mode (done at the ftp prompt)  
hash - optional; provides visual feedback that files are transferring.  
prompt - optional; avoids having user input “y” to transfer each file.
```

19. Change the directory to the CD ROM drive or where the release 3.0 software is located. Replace the “r” in the following command with the proper CD drive designator.

```
lcd r:/versionUpgrade (This command is for PC systems only. For UNIX system  
commands, see the system administrator for mounting a CD ROM on UNIX.)  
cd /tmp/p3 - changes the directory on the slot_2 NMIC  
mput * - transfers files from the workstation CD drive to the slot_2 NMIC  
bye - exits the ftp session
```

20. From the workstation shell, ftp the software from the Cellworx CD to the directory previously created for the software on the slot\_4 NMIC.

```
ftp [IP address of the slot_4 NMIC]
```

**bin** - sets the binary file transfer mode

**hash** - optional; provides visual feedback that files are transferring.

**prompt** - optional; avoids having user input “y” to transfer each file.

21. Change the directory to the CD ROM drive or where the release 3.0 software is located. Replace the “r” in the following command with the proper CD drive designator.

**lcd r:\versionUpgrade** (This command is for PC systems only. For UNIX system commands, see the system administrator for mounting a CD ROM on UNIX.)

**cd /tmp/p3** - changes the directory on the NMIC

**mput \*** - transfers files from the workstation CD drive to the slot\_4 NMIC

**bye** - exits the ftp session

#### INSTALL NEW SOFTWARE ONTO NMIC

- **Note:** The following upgrade steps will not take affect until the upgrade script is run on each NMIC. These steps only copy the images into place.

22. From the slot\_2 NMIC shell, upgrade the kernel by entering the following command:

```
/sbin/.cw/cw_upgradkernel /tmp/p3/xImage.3.0.0.7
```

23. From the slot\_4 NMIC shell, upgrade the kernel by entering the following command:

```
/sbin/.cw/cw_upgradkernel /tmp/p3/xImage.3.0.0.7
```

24. From the slot\_2 NMIC shell, upgrade the new operating system (OS) by entering the following command:

```
/sbin/cwupgrade /tmp/p3/ADC-Linux-upgrade-3.0.1.0-1.ppc.rpm
```

- **Note:** Wait for the second prompt “Done” to appear before continuing.

25. From the slot\_4 NMIC shell, upgrade the new operating system (OS) on the slot\_4 NMIC by entering the following command:

```
/sbin/cwupgrade /tmp/p3/ADC-Linux-upgrade-3.0.1.0-1.ppc.rpm
```

- **Note:** Wait for the second prompt “Done” to appear before continuing.

**DLP-780**

Page 6 of 10

26. From the slot\_2 NMIC shell, install the AIC/RIC and SCC software images by entering the following commands:

```
/sbin/cwupgrade /tmp/p3/AicSccSwImages-3.0.1-2.ppc.rpm
```

27. From the slot\_4 NMIC shell, install the AIC/RIC and SCC software images on the slot\_4 NMIC by entering the following commands:

```
/sbin/cwupgrade /tmp/p3/AicSccSwImages-3.0.1-2.ppc.rpm
```

28. From the slot\_2 NMIC shell, install the AIC/RIC and SCC bootrom flash images by entering the following commands:

```
/sbin/cwupgrade /tmp/p3/AicSccBootroms-3.0.1-2.ppc.rpm
```

29. From the slot\_4 NMIC shell, install the AIC/RIC and SCC software images by entering the following commands:

```
/sbin/cwupgrade /tmp/p3/AicSccBootroms-3.0.1-2.ppc.rpm
```

30. Install the AIC bootrom flash patch image on the slot 2 NMIC:

```
/cellworx/bin/installFlashImage aic 2.1.0.25 /tmp/p3/bootrom.2.1.0.25.bin
```

31. Install the AIC bootrom flash patch image on the slot 4 NMIC:

```
/cellworx/bin/installFlashImage aic 2.1.0.25 /tmp/p3/bootrom.2.1.0.25.bin
```

32. From the slot\_2 NMIC shell, enter the following commands to install the Cellworx NMIC software:

```
/sbin/cwupgrade /tmp/p3/cellworx-3.0.1.0-1.ppc.rpm
```

```
/sbin/cwupgrade /tmp/p3/cellworx-3.0.1.0p-1.ppc.rpm
```

33. From the slot\_4 NMIC shell, install the Cellworx NMIC software:

```
/sbin/cwupgrade /tmp/p3/cellworx-3.0.1.0-1.ppc.rpm
```

```
/sbin/cwupgrade /tmp/p3/cellworx-3.0.1.0p-1.ppc.rpm
```

34. From the slot\_2 NMIC shell, install the Feature Package software by entering the following command and replacing the “x” with an a, or c depending on the feature package ordered:

```
/sbin/cwupgrade /tmp/p3/FeatureControl_a(x)-3.0-1.ppc.rpm
```

35. From the slot\_4 NMIC shell, install the Feature Package software by entering the following command and replacing the “x” with an a, or c depending on the feature package ordered:

```
/sbin/cwupgrade/tmp/p3/FeatureControl_a(x)-3.0-1.ppc.rpm
```



## Download New Flash Images to SCCs and SEPICs

► **Note:** To avoid traffic loss during the upgrade procedure, the following steps must be performed.

36. Open the CellworxVision GUI. For each NE in the ring, perform the following two steps:
  - Open the Flash Upgrade screen and select the 3.0.0.5 flash image for each Shelf Controller in the shelf (slots 1 and 18), and hit the 'Apply' button. **\*\*\*\*\*DO NOT RESET THE SHELF CONTROLLER FOLLOWING DOWNLOAD OF THE NEW FLASH IMAGE\*\*\*\*\***
  - For each SEPIC in the shelf (note that this includes SEPICs on both Ring Network Elements as well as Expansion Shelves), select the 2.1.0.25 flash image and hit the 'Apply' button. **\*\*\*\*\*DO NOT RESET THE SEPIC FOLLOWING DOWNLOAD OF THE NEW FLASH IMAGE\*\*\*\*\***

## Upgrade The Standby NMIC (Slot 4)

37. In the slot 4 NMIC shell, change to the directory in which the software upgrade process is located:

```
cd /cellworx/swImage/swLoad_Ver3/nmic.3.0.1.0/bin
```

38. Start the software upgrade process. (The entire procedure for upgrading the slot 4 NMIC (standby NMIC) should take no more than 15 minutes.) This step invokes a graphical procedure that is used to walk the user through all required steps for upgrading the slot 4 NMIC.

► **Note:** The user should keep the NMIC shell open following this procedure, as a manual reboot of the slot 4 NMIC following upgrade will be necessary. At the end of this procedure, the application software on the slot 4 NMIC will be halted, and the LEDs will turn red.

39. The -h flag in the following command is used to specify the number of hours in which software fallback is allowed. Valid values are 0-168 (up to and including 7 days). The default value is 24 hours. For example, a value of 48 means the user cannot perform software fallback after 48 hours following software upgrade:

```
./cw_swupgrade -s 3.0.1.0 -h (hours)
```

## UPGRADE THE ACTIVE NMIC (SLOT 2)

40. After standby NMIC upgrade completion (the LEDs on the slot 4 NMIC faceplate should be red), start the software upgrade procedure on the slot 2 NMIC (the active NMIC). This step invokes a graphical procedure that walks the user through the necessary steps for

**DLP-780**

Page 8 of 10

upgrading software for the entire ring. The user should follow the directions and load release 3.0 software onto each AIC, RIC, and SCC in the ring:

```
cd cellworx/swImage/swLoad_Ver3/nmic.3.0.0.8/bin  
./cw_swupgrade -a 3.0.1.0 -h (hours)
```

41. Periodically click the Refresh button on the software configuration screen(s) to see when the software download is completed for each NE. Optionally, the user may close all software configuration screens and use the Refresh button on the main status screen. Clicking this button is equivalent to clicking the Refresh button on each of the NE's software configurations screens.
42. When the release 3.0 software download is complete for each NE, its entry in the main status screen will read, "NE is eligible for switchover." This must be done for all NEs in the ring.
43. Step 8 of the Task Overview (this is the window that outlines the software upgrade tasks, with check marks placed beside completed tasks and a hand pointing to the task in progress) allows the user to cancel the upgrade procedure. Note that this is not traffic affecting and a NMIC reset is unnecessary.
44. Step 12 of the Task Overview also allows the user to cancel the procedure. Note that this is also not traffic affecting but does require the slot 2 NMIC to be rebooted.
45. Following step 12 of the GUI Task Overview, any problems that cause software upgrade to fail can be traffic affecting. Should any assistance be needed at any point after this step, contact ADC Technical Support at 1-800-366-3891, extension 4878.
46. Following the slot 2 NMIC upgrade, this NMIC is automatically rebooted. After reboot, it will be running release 3.0 software. Note that until each of the SCCs reach their 5-minute switchover time and performs a soft reset, there will be a window of time during which communication is lost between the slot 2 NMIC and the SCCs. This window should be no more than 10 minutes.
47. After the slot 2 NMIC has successfully rebooted, log back into it and start the Cellworx GUI. Replace "[hostname]" in the following commands with the IP address of the laptop or workstation:

```
telnet [IP address of the slot 2 NMIC]  
export DISPLAY=[hostname]:0  
/cellworx/bin/CellworxVision
```

48. After the Cellworx GUI has been started on the slot 2 NMIC, manually reboot the slot 4 NMIC by entering the following command in the slot 4 NMIC shell window:

```
/sbin/reboot
```

49. After the slot 4 NMIC reboots, a database restoration window will appear on the Cellworx GUI screen from the slot 2 NMIC.

► **Note:** It is imperative that the user selects the slot 2 NMIC for database restoration because only the database files on this NMIC were converted from release 2.0 format to release 3.0 format.



**Warning:** Following the software upgrade procedure, there are several actions that could invalidate software fallback. The user **SHOULD NOT** perform any of the following tasks unless he is certain that a software fallback from release 3.0 to release 2.0 is not necessary.

- Make any topology modifications (add/remove NE, all shelf types)
- Remove any existing cards
- Delete any existing connections
- Change the time of day clock
- Perform a ring upgrade (OC3c --> OC12c, etc.)
- Remove any file in the /cellworx/config directory with the extension, ".release2.0". These files must be present in order to perform a software fallback.
- Also be aware of the following restrictions:
- If a release 3.0 card is installed in a shelf (such as DS3 CES or T1/E1 Frame Relay), remove that card before performing software fallback.
- Delete any connections that are created following software upgrade before attempting software fallback.

## UPGRADE THE BOOTROM FLASH

50. From the main GUI screen (which is running on the slot 2 NMIC), open the Gateway Network Element (GNE) pop-up menu by right-clicking on the GNE icon (the text underneath the GNE icon will be yellow - text for all other NE icons is in white). Select the Reflash Boot Image menu option.
51. In the resulting screen, select the release 3.0 bootrom for each card installed in the shelf (except the NMIC). To do this, right-click on each row in the table and select the appropriate bootrom image. The following images should be selected:

**SCC = 3.0.0.5** (the SCC flash image was previously installed in step 36)

**AIC/RIC = 3.0.1.2**

54. Once release 3.0 bootrom images have been selected for all cards in the GNE shelf, click the Apply button. Wait about 5 minutes and then click the Refresh button to update the

**DLP-780**

Page 10 of 10

download status for the cards. All cards should say, "Loaded". If not, wait a few more minutes and click Refresh again.

55. Once all cards are loaded with the release 3.0 bootrom, each card in the shelf must be hard reset to load the new bootrom.

- ▶ **Note:** Hard resetting a card is traffic affecting. When you upgrade the flash bootrom on each card, you may want to take this into consideration. To minimize traffic loss, you should consider using 1+1 or 1:N protection and resetting the cards such that a card is always active. This will take longer, but you will avoid traffic loss.

56. Repeat steps 46 through 49 for each NE in the ring.

57. Following hard reset of all cards in all NEs in the ring, software upgrade is complete.

58. Following software upgrade, the user should manually delete the 2.1.0.25 AIC flash image that was installed previously. This will remove the possibility of inadvertently selecting this image in a Release 3.0 system:

```
rm -f /cellworx/flashImage/aic/bootrom_Ver2/bootrom.2.1.0.25
```

**Stop! You have completed this procedure.**

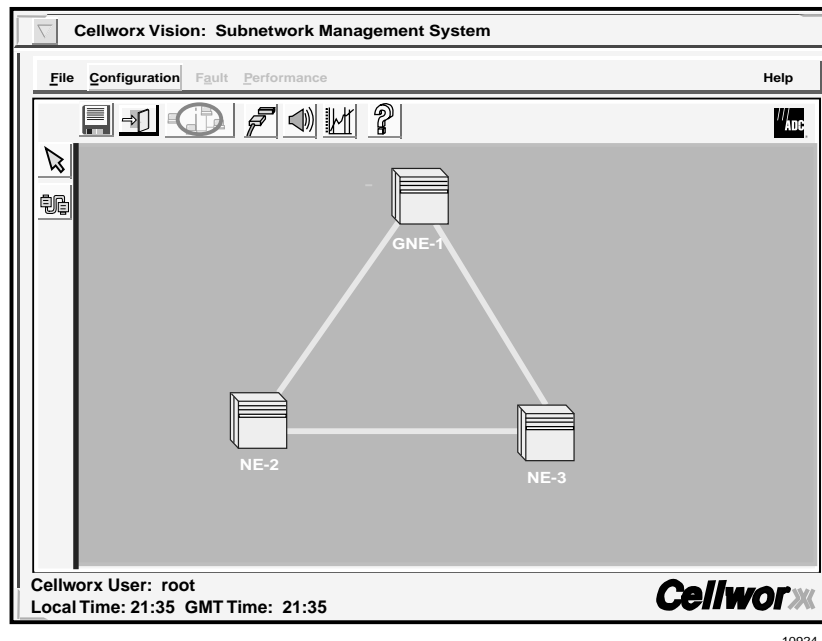

Figure 780-1. GUI Main Screen (example)

## REMOVING A NMIC CARD FROM THE SHELF

**Summary:** If replacing a defective NMIC card, it is preferable that it be shut down before removing.

1. If the NMIC is responsive to commands, plug the computer cable into the front access port located under the hinged front panel. Otherwise, go to step 4.

► **Note:** A terminal emulator (ProComm Plus or HyperTerminal) needs to be set up using 9600bps, 8bits, 1stop bit and no parity using a DB9 null modem cable wired as shown in Figure 781-1.

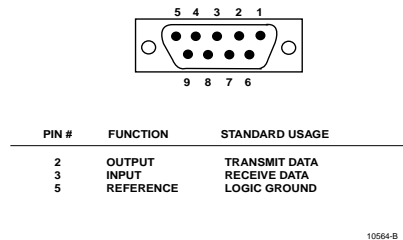

Figure 781-1. NMIC RS232 Port Cable Connector Wiring

2. At the Login: prompt. Log into the NMIC. From the factory the userid is root with NO password set. If the NMIC has been set up previously and you do not know the name and password, see your system administrator.
3. After logging into the NMIC a bash# prompt will appear Enter the following commands to execute a NMIC shut down:
  - `/usr/bin/killall psm` - Stops processes running on NMIC. If NMIC is fully operational than use this command. An operational NMIC can be identified by the two green LEDs, Status and Active.
  - `/usr/bin/shutdown -h` - Shuts down NMIC and halts it.
4. To remove a card from the shelf, pry outward on the ejector ears using the thumbs. This will dislodge the card from the backplane and allow it to be withdrawn from the card guides. Refer to Figure 781-2 for an example of removing a card from the front of the shelf.
5. Using one hand to support the card underneath as it is drawn out, remove the card with the other hand.
6. Place the card in an Electro-statically protected bag and place in the proper packaging material in anticipation for its return to ADC Telecommunications for evaluation.
7. Align the replacement card with the card guides in the shelf at the proper slot position holding the card with the component side facing right. Refer to Figure 781-3.

**DLP-781**

Page 2 of 3

10. Slide the card in until the ejector ears reach the card cage trough. Fully seat the card into the backplane by pressing the ejector ears toward the shelf until they rest against the faceplate. Do not use excessive force. If excessive resistance is felt, remove the module, check for alignment and/or obstructions, and try seating it again.
11. After replacing the card, the user may perform turn up of the NMIC per DLP-702.

**Stop! You have completed this procedure.**

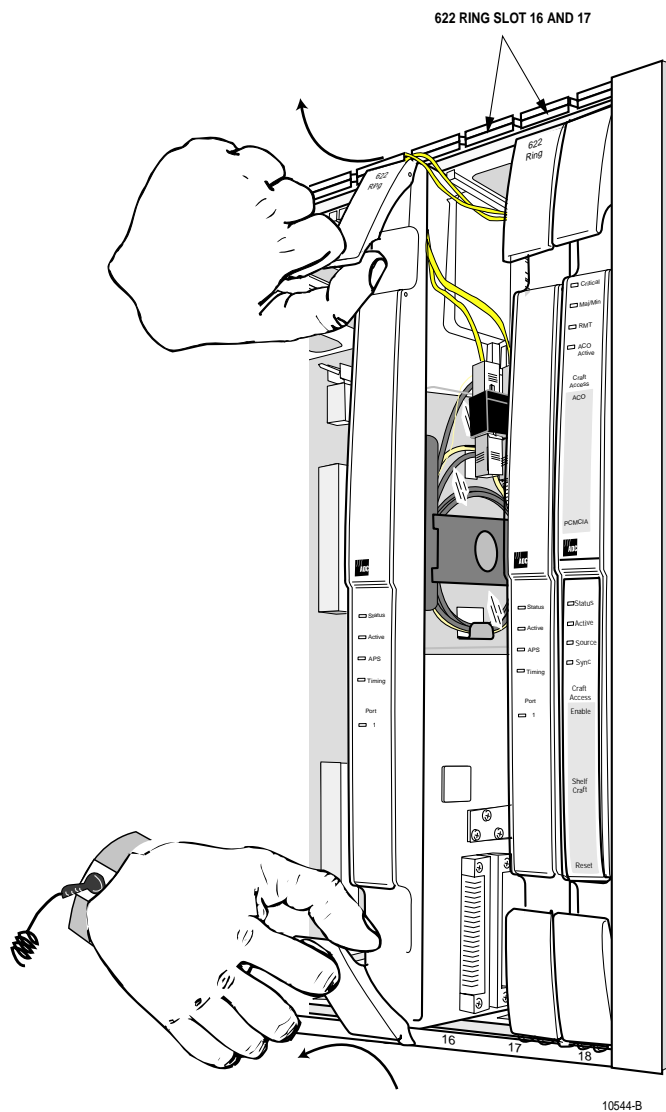

Figure 781-2. Example of Removing a Front Access Card

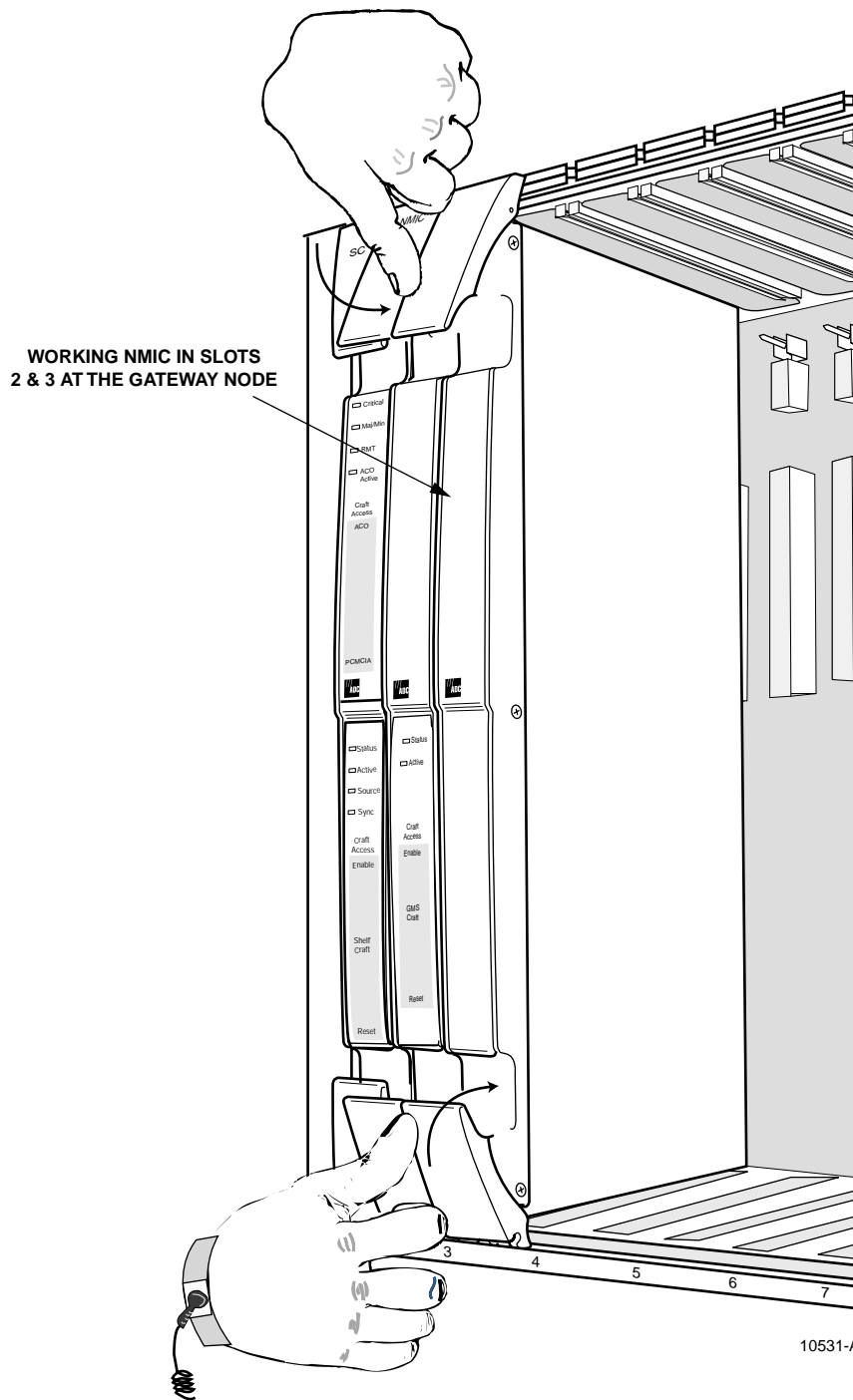

Figure 781-3 Example of Seating a Front Access NMIC Card

**DLP-782**

Page 1 of 6

**REBOOTING THE SYSTEM USING A SAVED OR DEFAULT DATABASE**

**Summary:** The following procedure defines the steps required to reboot the system using the database files previously stored from the NMIC, or clearing all existing database files and restarting the system from scratch. The database files can be used to restore a system if a catastrophic failure occurs and database corruption is imminent. Refer to DLP-745 for procedural information on saving the existing database. Section A below steps the user through the process of FTP'ing remote files to a tmp directory on the NMIC and rebooting using these files. Section B steps the user through the process of rebooting the system using a backup database previously stored on the NMIC in the config directory. For rebooting using the default system database and rediscovering the system from scratch go to section C below.

**A. FTP REMOTE DATABASE FILES TO THE NMIC AND REBOOT THE SYSTEM**

1. Telnet to the standby NMIC using the NMIC specific IP address.
2. Execute the following command to stop all processes running on the standby NMIC.
  - **killall psm**
3. Execute the following command to force the NMIC processes to die.
  - **killall -9 nmic ftpClnt**
4. Telnet to the active NMIC using the NMIC specific IP address.
5. Execute the following command to stop all processes running on active NMIC.
  - **killall psm**
6. Execute the following command to force the active NMIC processes to die.
  - **killall -9 nmic ftpClnt**
7. Enter the following command to change to the directory where the database files are stored on the active NMIC.
  - **cd /cellworx/config**
8. Enter the following command to save off the corrupted NMIC db in case it is needed later:
  - **mv NMIC NMIC.corrupted**
9. Enter “**exit**” to return to a DOS prompt.
10. FTP to the NMIC by entering the following command at the DOS prompt:
  - **ftp <active NMIC IP address>**



11. Logon to the NMIC using any user name and password other than the root user.
12. From the ftp prompt, change to the temp directory by entering the following command:
  - **ftp> cd /tmp**
13. Set the transfer mode to binary, (turn on the hash marks for progress indication), (and turn off the system prompting) by entering the following commands at the ftp prompt:
  - **ftp> bin**
  - **ftp> hash** (optional)
  - **ftp> prompt** (optional)
14. Put the NMIC files from the workstation onto the NMIC by entering the following command:
  - **ftp> put NMIC**
15. Put the multiple NE files from the workstation backup copy onto the NMIC by entering the following command:
  - **ftp> mput NE.? NE.??**
16. After the files have been transferred to the NMIC, enter “quit” to return to the DOS prompt.
17. Establish a Telnet session with the active NMIC again and logon as the root user.
18. At the bash prompt, enter the following command to change to the directory where the new database files are stored on the active NMIC.
  - **cd /tmp**
19. From the bash prompt, enter the following commands to associate the tmp files with the root user.
  - **chmod 644 NMIC**
  - **chmod 644 NE.\***
  - **chown root NMIC**
  - **chown root NE.\***
  - **chgrp root NMIC**
  - **chgrp root NE.\***

**DLP-782**

Page 3 of 6

20. Enter the following command to restore the backup NMIC database. This will move the database to the active NMIC only. Leave spaces between the files.

- **mv /tmp/NMIC /tmp/NE.\* /cellworx/config**

21. Enter the following command to reboot the active NMIC.

- **/sbin/reboot**

22. On the standby NMIC: wait 60 seconds and then enter the following command to reboot:

- **/sbin/reboot**

23. When the active NMIC comes back up, logon to it.

24. Configure the NMIC to launch the display back to the proper machine by entering the following command:

- **export DISPLAY=x.x.x.x:0.0**

► **Note:** Here the x.x.x.x is the valid IP address of the PC or workstation that is to receive the display.

25. Start the Graphical User Interface (GUI) by entering the following command at the NMIC prompt

- **CellworxVision**

26. The GUI display should appear on the designated PC or workstation. If the NMIC gives a message indicating it is unable to launch the display make sure the workstation in use is configured to accept displays from other machines. This is done by typing “xhost +” on the command line of the workstation (not the NMIC).

27. When the standby NMIC starts, the NMIC Protection Restoration screen will appear because the database files are not synchronized. The operator **MUST** choose the correct NMIC to restore from to get the correct files synchronized on both NMICs. The currently active NMIC (the NMIC on which the database copies were done and the first to reboot) should be chosen for the restoration.

**Stop! You have completed this procedure.**

**B. REBOOTING THE SYSTEM USING A BACKUP DATABASE STORED ON THE NMIC**

28. Telnet to the standby NMIC using the NMIC specific IP address.

29. Execute the following command to stop all processes running on the standby NMIC.

- **killall psm**

30. Execute the following command to force the NMIC processes to die.
  - **killall -9 nmic ftpClnt**
31. Telnet to the active NMIC using the NMIC specific IP address.
32. Execute the following command to stop all processes running on active NMIC.
  - **killall psm**
33. Execute the following command to force the active NMIC processes to die.
  - **killall -9 nmic ftpClnt**
34. Enter the following command to change to the directory where the database files are stored on the active NMIC.
  - **cd /cellworx/config**
35. Enter the following command to save off the corrupted NMIC db in case it is needed later:
  - **mv NMIC NMIC.corrupted**
36. Enter the following command to move the backup copy of the NMIC database to the working copy of the NMIC database.
  - **mv NMIC.backup NMIC**
37. Enter the following command to reboot the active NMIC.
  - **/sbin/reboot**
38. On the standby NMIC: wait 60 seconds and then enter the following command to reboot:
  - **/sbin/reboot**
39. When the active NMIC comes back up, logon to it.
40. Configure the NMIC to launch the display back to the proper machine by entering the following command:
  - **export DISPLAY=x.x.x.x:0.0**

► **Note:** Here the x.x.x.x is the valid IP address of the PC or workstation that is to receive the display.
41. Start the Graphical User Interface (GUI) by entering the following command at the NMIC prompt
  - **CellworxVision**

**DLP-782**

Page 5 of 6

42. The GUI display should appear on the designated PC or workstation. If the NMIC gives a message indicating it is unable to launch the display make sure the workstation in use is configured to accept displays from other machines. This is done by typing “xhost +” on the command line of the workstation (not the NMIC).
43. When the standby NMIC starts, the NMIC Protection Restoration screen will appear because the database files are not synchronized. The operator **MUST** choose the correct NMIC to restore from to get the correct files synchronized on both NMICs. The currently active NMIC (the NMIC on which the database copies were done and the first to reboot) should be chosen for the restoration.

**Stop! You have completed this procedure.**

**C. REBOOTING THE SYSTEM USING THE DEFAULT DATABASE.**

44. Telnet to the standby NMIC using the NMIC specific IP address.
45. Execute the following command to stop all processes running on the standby NMIC.
  - **killall psm**
46. Execute the following command to force the NMIC processes to die.
  - **killall -9 nmic ftpClnt**
47. Telnet to the active NMIC using the NMIC specific IP address.
48. Execute the following command to stop all processes running on active NMIC.
  - **killall psm**
49. Execute the following command to force the active NMIC processes to die.
  - **killall -9 nmic ftpClnt**
50. Enter the following command to change to the directory where the database files are stored on the active NMIC.
  - **cd /cellworx/config**
51. Enter the following command to save off the corrupted NMIC db in case it is needed later:
  - **mv NMIC NMIC.corrupted**
52. Display a list of the NE files that exist on the NMIC by entering a “**ls**”. The system displays all the files within the config directory. Take note of each file and delete the NE database files for the NEs that exist in the system.

**Example:** If a three node ring with one expansion shelf is used with NE.1, NE.2 and NE.3 and NE.4, then the following command would need to be entered on the NMIC:

- `rm /cellworx/config/NE.?`

53. For each NMIC, delete the NMIC configuration file using the following command:

- `rm /cellworx/config/NMIC`

54. Perform a “**shutdown -h now**” on each NMIC to halt the LINUX operating system.

55. Reboot all the nodes in the system, rebooting the node containing the NMICs last. Rebooting requires extracting and reinserting all cards in the shelf. The Shelf Controller and the NMIC can alternatively be rebooted without extraction by simultaneously pressing the enable and reset buttons under the front panel of the card.

56. At this point follow the complete ring turn-up procedure described in NTP-002.

**Stop! You have completed this procedure.**

**DLP-783**

Page 1 of 4

**ADD/DELETE GUI USERS OR CHANGE GUI USER LEVEL SECURITY**

**Summary:** The NMIC supports up to 5 simultaneous GUI users and 3 external Network Management Systems (ENMS), meaning that the NMIC will allow the users to issue multiple requests to the system at the same time. There are three user access (privilege) levels defined as follows:

- **LEVEL3** - The highest possible user level. A LEVEL3 user has write access to all NMIC GUI commands when they are applicable. The LEVEL3 user has write access to all NMIC platform functionality's (e.g. setting time and file replication), as well as make topology changes (e.g. add NE or remove NE). The LEVEL3 user is a NMIC GUI admin only, and does not imply root privileges in a LINUX environment. It should be noted that due to multi-users, only the first LEVEL3 GUI user to logon is allowed to make topology changes or do protection switching/restoration.
  - **LEVEL2** - The second highest user level. A LEVEL2 user has write access to most screens when applicable. The LEVEL2 user cannot make NMIC platform changes, topology changes, or administer craft security.
  - **LEVEL1** - The lowest user level. A LEVEL1 user has read access only, and may not be able to access certain screens. A LEVEL1 user is not permitted to do any action that would be database (written to the database) or traffic affecting. However, a LEVEL1 user is able to modify user specific information such as the icon layout.
- **Note: Modifying Objects** – When the NMIC receives multiple simultaneous requests to modify the same piece of data, the requests are treated as if they were sent one at a time and in a given order. The last modification requests received will override any previous modifications. This method of handling this access pattern is consistent with how it is handled with a single user.
- **Note: Retrieving Read-Only Data** - If one user is in the process of modifying a managed object, then a second user requests data for the same managed object, the second user must wait for the completion of the first user set request to ensure that he does not get inconsistent data. The reverse is also true if one user is attempting to get a piece of data while another user try to modify it. The second user request must wait until the completion of the first request before it can be honored. However, if the two users access data in completely different "domains of control" then it is possible to honor both requests simultaneously.

There are some administrative operations which really make no sense for multiple users to perform such as : ring turnup, add NEs, delete NEs, etc. For these kind of activities, multiple users access will NOT be allowed. Instead the GUI only allows the GUI user with an Id of one(1) to have access to this functionality.

1. From the workstation establish a Telnet session to the Cellworx system using the floating NMIC IP address.
2. At the Login prompt, logon as the root user.

## CREATE A NEW USER

3. To create a new user, enter the following command using user defined variable for username, and the GUI defined access level of 1, 2 or 3. Refer to the summary for definitions of GUI user levels at the beginning of this procedure if needed. Use the LINUX command “make user” followed by a space, then the user name assigned by the administrator followed by a space, and the GUI access level followed by an *Enter* or *Return*.

- `mkuser <username> <GUI access level>`

4. The system responds with “created user <username> with user ID <id number>” and prompts the administrator for a LINUX password. If needed, enter a password for the user for authentication purposes followed by an *Enter* or *Return*. The password will not appear on the screen as you type. This will allow the user to access the LINUX system but does not affect the graphical user interface access.
  - ◆ **Note:** The LINUX system will not allow a password that is defined as a dictionary word or based upon any user information that is considered unsecured.
5. The system asks the user to retype the password. Retype the password entered in step 4 exactly as it was entered previously followed by an *Enter* or *Return*.
6. The system should respond with “all authentication tokens updated successfully”. If the password was not reentered correctly, the system prompts the user to start the LINUX password process over.
7. The system now prompts the user for “finger” information on the new user. The finger information enables the administrator to identify users by their logon name and “finger” them in system activities. Enter the real user’s name followed by an *Enter* or *Return*.
8. The system asks for the office number of the new user. Enter the office number if applicable followed by a *Enter* or *Return* or just skip it by hitting *Enter* or *Return*.
9. The system then asks for the office phone number of the new user. Enter the office phone number for contact information purposes if needed followed by an *Enter* or *Return* or just skip it by hitting *Enter* or *Return*.
10. The system prompts for the home phone number of the new user. Enter the home phone number for contact information purposes if needed followed by an *Enter* or *Return* or just skip it by hitting *Enter* or *Return*.

**DLP-783**

Page 3 of 4

11. The system responds with “Finger Information Changed” and then adds the new user to the GUI access level group requested. The system attempts to “replicate” or copy the new data to the “peer” or stand-by NMIC. If successful, the system responds with “Replicated user data to peer NMIC” and returns the administrator to the root prompt. If a stand-by NMIC is not available or not installed, the system responds with “Failed to replicate user data to peer NMIC.” If so, the user will have to perform a NMIC Protection Restoration per DLP-725 once the stand-by NMIC is brought into service.

**VIEW ALL ACTIVE GUI USERS**

12. The administrator can display all GUI users that are currently logged onto the system by entering the following command at the root bash prompt exactly as shown:

- **manageGui**

13. The system displays all active users one through five and indicates the “1<sup>st</sup> Privileged User” as shown in Figure 783-1. This is the first Level 3 user who logged onto the system and in doing such is the only one that can make topology changes and perform protection switches/restoration. If logged on as the root user, you have the privilege of “killing” the GUI sessions of other users at this point. The system prompts the administrator to type in the number of the user to boot off (numbers 1 to 5).

```
ADC LINUX for Cellworx (R)
Warning: Unauthorized use of this
system may lead to prosecution.
login: root
Last login: Mon May 8 09:36:45 from 155.xxx.245.xxx
[root@ltar040 /root]# manageGui

This is a list of GUIs currently active:::
GUI Id = 1: User = root DISPLAY=155.xxx.245.123:0.0 (1st Privileged User)
GUI Id = 2 is not currently active
GUI Id = 3 is not currently active
GUI Id = 4 is not currently active
GUI Id = 5 is not currently active
Please enter the GUI Id of the GUI to be terminated or -1 to exit :
```

Figure 783-1. Terminal Display of Managing GUI



## REMOVE A USER

14. To remove a GUI user from the system database, enter the LINUX command “remove user” as shown followed by a space, then the username assigned by the administrator followed by an *Enter* or *Return*.

- **rmuser <username>**

15. The system responds with “user <username> has been deleted”. The system attempts to “replicate” or copy the new data to the “peer” or stand-by NMIC. If successful, the system responds with “Replicated user data to peer NMIC” and returns the administrator to the root prompt. If a stand-by NMIC is not available or not installed, the system responds with “Failed to replicate user data to peer NMIC. If so, the user will have to perform a NMIC Protection Restoration per DLP-725 once the stand-by NMIC is brought into service.
16. The system then asks the administrator if he wishes to remove the deleted users home directory. It is recommended that the deleted user’s directory be deleted as this will free up space on the drive. This directory contains topology layout information and other information specific to that user and will not effect the other users. Enter a “Y” followed by an *Enter* or *Return*.

## CHANGE USER ACCESS LEVEL

17. To change the access level of a current user, the administrator can enter the following command using the user defined variable for username, and the GUI defined access level of 1, 2 or 3. Refer to the summary for definitions of GUI user levels at the beginning of this procedure if needed. Use the LINUX command “change access” followed by a space, then the user name assigned by the administrator followed by a space, and the new level of GUI access to be assign to the existing user followed by an *Enter* or *Return*.

- **chaccess <username> <GUI access level>**

18. The system responds with “Changing user <username> to access level <GUI access level>.” The system attempts to “replicate” or copy the new data to the “peer” or stand-by NMIC. If successful, the system responds with “Replicated user data to peer NMIC” and returns the administrator to the root prompt. If a stand-by NMIC is not available or not installed, the system responds with “Failed to replicate user data to peer NMIC.” If so, the user will have to perform a NMIC Protection Restoration per DLP-725 once the stand-by NMIC is brought into service.
19. Next the system prompts the administrator to instruct the user changed to exit his/her GUI and restart it so the access level can take effect. This is intended to inform the user that until the exit takes place, the new changes will not take effect.

**Stop! You have completed this procedure.**

**DLP-784**

Page 1 of 7

**SET FE1 FRS CARD CONFIGURATION**

**Summary:** This procedure details the steps required to set the FE1 FRS card configurations utilizing the Cellworx STN Phase 3.1 shelf level Graphical User Interface (GUI). User must have the GUI launched, and have accessed the shelf level GUI display per NTP-006 prior to performing this procedure.

1. Double click on the FE1 FRS card displayed in the shelf level GUI “Chassis View” at the top of the window. The FE1 FRS card display appears as shown in Figure 784-1.
2. Click and drag the small block upward to expand the Configuration section of the window so all or most options are visible. The Administrative State of the card and port should be “Unlocked” if in service. If “Locked”, select the “*Unlocked*” option using the left mouse button to enable the card and/or port for service.
3. Set the Ingress and Egress Congestion Threshold for the switch fabric which will generate an alert when the traffic congestion crosses the threshold set.
4. Set the Ring Selection to Auto, Ring 16, or Ring 17 as required. Refer to Table 784-2 for definitions of all options selectable by the user.
5. Following the Ring Selection is the Smoothing Constant option. Click on the up or down arrow to select from 0.1 to 1.0 in .1 increments. This value provides for exponential smoothing for alarm notices that report/respond to congestion in the frame relay buffers. A smaller number (0.1) will reduce chattering of alarm notices/clearings due to buffer congestion during spikes in traffic.
6. Following the Smoothing Constant settings is the Ingress and Egress, High and Low Buffer Congestion Thresholds settings for the frame relay buffers. Refer to Figure 784-2 for instructions on setting the thresholds.
7. Following the Congestion Threshold settings, set the Port Mode for channelized or fractional as required via the display shown in Figure 784-3.

► **Note:** Selecting Channelized options will configure the card for four ports only (1, 2, 3, and 4). Refer to Table 784-1 below for Port Level configuration options:

Table 784-1. FRS Port Configurations

MODE	PORT							
	1	2	3	4	5	6	7	8
Channelized	CH	CH	CH	CH			--	--
Fractional	FR	FR	FR	FR	FR	FR	FR	FR
Combinations	CH	CH	FR	FR			FR	FR
	FR	FR	CH	CH	FR	FR	--	--

- **Note:** The user may not change the Port Mode if there is an existing interface configured on that port.
8. Click and drag the small block to expand the Port Level configuration section of the window.
  9. Select a Port on the simulated card by a single click on the port LED using the left mouse button. This will bring up the configuration data for that port in the Port Level section of the window. Ensure the Administrative State is set to Unlocked to enable the port for service.
  10. Set the Port Level configuration options per requirements. Refer to Table 784-2 for a list of options the user may select for this card type.
  11. Hit the **Apply** button at the bottom of the window to back up the new configuration data to the shelf controller and configure the port before attempting to create interfaces on the port.

► **Note:** Selecting **Chassis View** will return the user to the previous window without closing the FE1 FRS window. Selecting **Refresh** will update the current window display with all the selections last recorded by the Shelf Controller card. Selecting **Close** will close this window and return the user to the Chassis View window.
  12. Double click on the port just configured (1 to 8, depending on Port Mode selected) to bring up the Frame Relay Interface screen. Refer to the example shown in Figure 784-4. Within this screen, the user may elect to change the port interface by double clicking on the port desired in the Circuit box on the left.
  13. There are 24 DS0 channels selectable for the interface in the Interface Selection block of the window. If creating a Channelized connection, the user may create up to 24 single interfaces, or multiple interfaces made up of any number of contiguous channels using this tool. If creating a Fractional connection, the user may select up to 24 channels to create a single interface one time. The system will then indicate "Interface Creation Disabled". Select the individual or range of DS0 channels to create the first interface using the left mouse button. Click on the first channel and then on the last contiguous channel of the range. The channels will become white and are shown linked by a bracket in the window. The GUI indicates this is the number 1 interface and shows it as the "Current" selection.
  14. In the main block of the window the user can assign multiple identifiers, and configure the interface. Refer to Table 784-3 for definitions of each option. Once all interface data is entered, select the **Apply** button at the bottom of the screen to create the interface on the port.
  15. The user may now select the next channel(s) for another channelized interface and repeat step 13 or select **Close** and return to step 9 to create the next Port Level configuration. If creating another channelized interface on this port, the user will notice the color changes to

**DLP-784**

Page 3 of 7

blue for the next channel(s) selected and the system will number it 2 and indicate it is the “Current” channel. If multiple interfaces are displayed, the user must “double-click” on any channel of the interface desired to make it “Current” to allow configuration changes or to delete that interface.

16. Select the *Close* button to return to the FE1 FRS card display.
17. Select the *Close* button to return to the Chassis View window.
18. Repeat steps 1 through 17 for each card in the shelf.

**Stop! You have completed this procedure.**

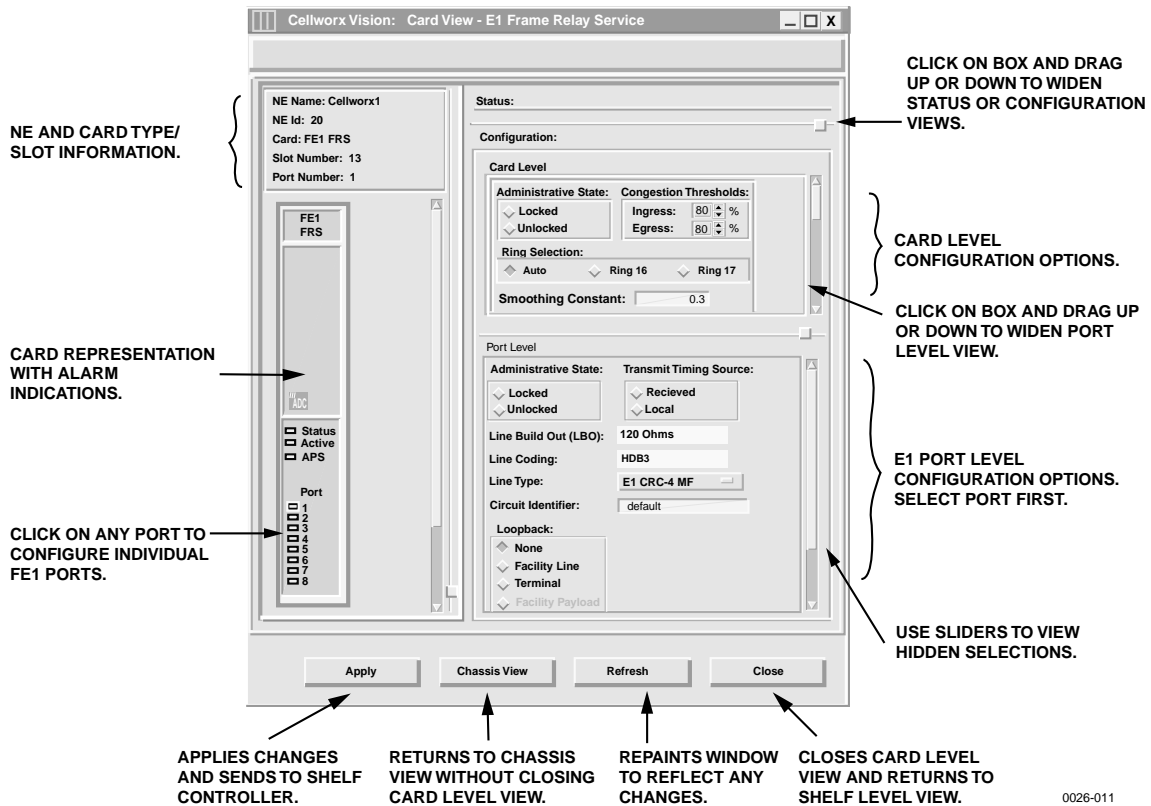

**Figure 784-1. FE1 FRS Card Configuration Window**

CLICK ON THE UP OR DOWN ARROWS TO INCREASE OR DECREASE THE VALUE WHICH PROVIDES EXPONENTIAL SMOOTHING FOR ALARM NOTICES THAT REPORT/RESPOND TO FR BUFFER CONGESTION

Smoothing Constant:

Ingress:

Low Buffer Congestion Threshold:

Abatement **40**

Onset

High Buffer Congestion Threshold:

Abatement **65**

Onset

SELECT THE BLACK BLOCK AND DRAG TO THE DESIRED BUFFER CONGESTION THRESHOLD FOR ALARM ABATEMENT. THIS VALUE WILL BE 10 PERCENT LESS THAN THE THRESHOLD ONSET.

SELECT THE RED BLOCK AND DRAG TO THE DESIRED BUFFER CONGESTION THRESHOLD FOR ALARM ONSET. ANY CELLS TAGGED AS DISCARD ELIGIBLE FOR ANY INTERFACE AND PORT MAY BE DISCARDED ONCE THIS THRESHOLD IS CROSSED.

0026-001

Figure 784-2. FRS Buffer Congestion Threshold Settings

Port Mode:

Ports 1 and 2 Channelized; Ports 5 and 6 disabled

Ports 1, 2, 5, and 6 Fractional

Ports 3 and 4 Channelized; Ports 7 and 8 disabled

Ports 3, 4, 7, and 8 Fractional

SELECT THE DESIRED PORT CONFIGURATION AND THEN HIT THE APPLY BUTTON. NOTE THAT IF SELECTING CHANNELIZED CONFIGURATION, PORTS 5 AND 6, AND/OR 7 AND 8 WILL NOT BE SELECTABLE FOR INTERFACE CONFIGURATION.

0026-021

Figure 784-3. FRS Port Mode Settings

**DLP-784**

Page 5 of 7

**Table 784-2. FE1 FRS Card Configuration Options**

SELECTION	DEFAULT	OPTIONS	DEFINITIONS
Card and Port Administrative State	Unlocked	Unlocked Locked	Enables or disables card/port for service, respectively.
Congestion Threshold	80	0-100	Percentage of ingress/egress buffer capacity that will cause a congestion threshold notification.
Ring Selection	Auto	Auto Ring 16 Ring 17	Card will automatically select traffic from the ring direction with the best signal. Card will receive traffic from Ring 16 direction. Card will receive traffic from Ring 17 direction.
Low Ingress/Egress Buffer Congestion Onset/Abatement	<default>	Variable	This will cause the FECN/BECN in the frame relay header to be set or cleared. Abatement is always ten percent less than onset.
High Ingress/Egress Buffer Congestion Onset/Abatement	<default>	Variable	Exceeding threshold causes frames with DE field equal to 1 to be discarded. Frame discarding stops upon reaching abatement level. Abatement is always ten percent less than onset.
Transmit Timing Source	Local	Received Local	Incoming clock pulse used for outgoing signal. Clock pulse supplied by the SC cards used for outgoing signal.
Service Type	FRS	FRS	Frame Relay Service.
Line Build Out	120 Ohms	120 Ohms	Sets the signal strength according to the distance in feet that the Cellworx STN is from the E1 interfacing equipment, not user configurable.
Line Coding	HDB3	HDB3	European Standard, not user configurable.
Line Type	E1	E1 E1 MF E1 CRC-4 E1 CRC-4 MF	
Circuit Identifier	<default>	Up to 20 alphanumeric characters.	User defined. Usually describes the traffic, customer, and/or channel number.
Loopback	None	None Facility Line Terminal Facility Payload	No Loopback selected. Loops frames back out to EIM. Loops ATM cells back to Cellbus. Not user selectable on FE1 FRS interfaces.
Far End Loopback	None	N/A	Not user selectable on FE1 FRS interfaces.

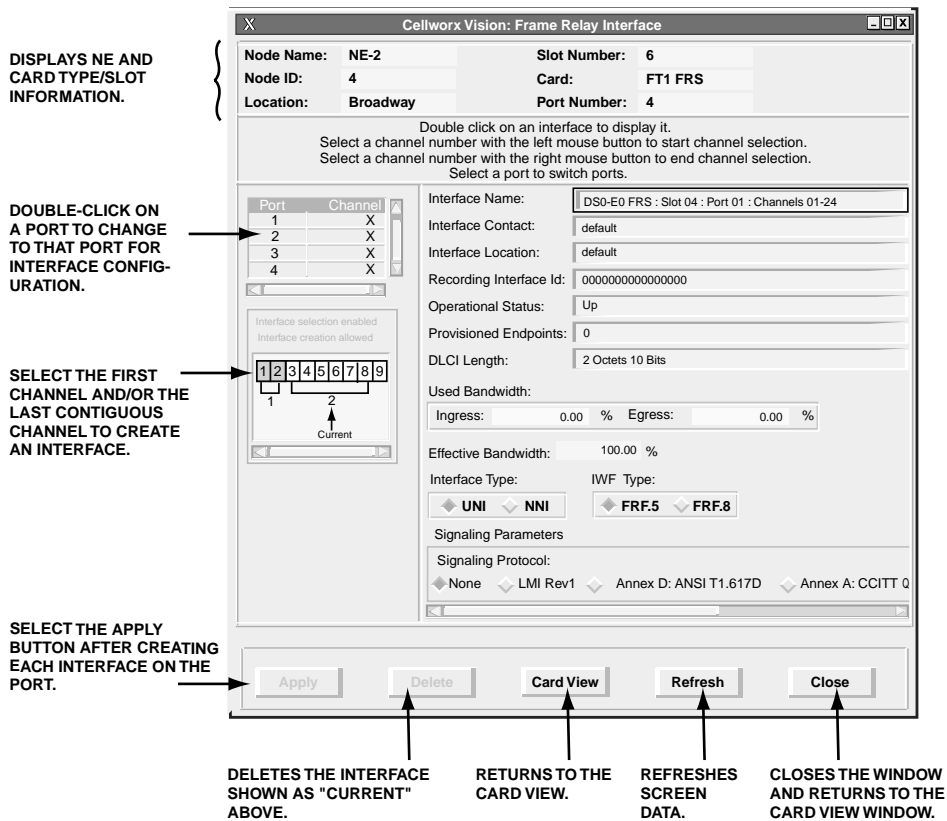

0026-012

Figure 784-4. FE1 FRS Interface Configuration Window

Table 784-3. FE1 Frame Relay Interface Configuration Options

SELECTION	DEFAULT	OPTIONS	DEFINITIONS
Interface Name	<default>	Any alphanumeric characters.	User defined. Can describe the card type, slot, port, and/or channel number, etc.
Interface Contact	<default>	Any alphanumeric characters.	User defined. Can describe the name or number of a contact person or place.
Interface Location	<default>	Any alphanumeric characters.	User defined. Can describe the location of the interface (street, building, row, rack, shelf, etc.)
Recording Interface ID	All 0s	Numeric	Identifies the site card and port location for customer billing capabilities, (allows assignment of a customer ID for each port), limited to 15 numeric characters.

(continued)

**DLP-784**

Page 7 of 7

**Table 784-3. FE1 Frame Relay Interface Configuration Options, continued**

SELECTION	DEFAULT	OPTIONS	DEFINITIONS
Operational Status	Up	Display Only	Indicates the operational status of the interface.
Provisioned Endpoints	0	Display Only	Displays how many FR endpoints are configured by administrator on this interface.
DLCI Length	2 Octets 10 Bits	Display Only	Indicates the size of the data link connection identifier assigned to this interface.
Used Bandwidth	Traffic Dependant	Display Only	Indicates a percentage of Ingress and Egress bandwidth utilized for the selected interface.
Effective Bandwidth	Traffic Dependant	Display Only	Indicates a percentage
Interface Type	UNI	UNI NNI	User to Network Interface Network to Network Interface
IWF Type	FRF.5	FRF.5 FRF.8	Frame Relay Forum standards. Frame Relay to ATM internetworking type.
Signaling Protocol	None	None LMI Rev 1 Annex D: ANSI-T1.617D Annex A: CCITT-Q933A	Link Management Interface Protocol



## SET FT1 FRS CARD CONFIGURATION

**Summary:** This procedure details the steps required to set the FT1 FRS card configurations utilizing the Cellworx STN Phase 3.1 shelf level Graphical User Interface (GUI). User must have the GUI launched, and have accessed the shelf level GUI display per NTP-006 prior to performing this procedure.

1. Double click on the FT1 FRS card displayed in the shelf level GUI “Chassis View” at the top of the window. The FT1 FRS card display appears as shown in Figure 785-1.
  2. Click and drag the small block upward to expand the Configuration section of the window so all or most options are visible. The Administrative State of the card and port should be “Unlocked” if in service. If “Locked”, select the “*Unlocked*” option using the left mouse button to enable the card and/or port for service.
  3. Set the Ingress and Egress Congestion Threshold for the switch fabric, which will generate an alert when the traffic congestion crosses the threshold set.
  4. Set the Ring Selection to Auto, Ring 16, or Ring 17 as required. Refer to Table 785-2 for definitions of all options selectable by the user.
  5. Following the Ring Selection is the Smoothing Constant option. Click on the up or down arrow to select from 0.1 to 1.0 in .1 increments. This value provides for exponential smoothing for alarm notices that report/respond to congestion in the frame relay buffers. A smaller number (0.1) will stop chattering of alarm notices/clearings due to buffer congestion during spikes in traffic.
  6. Following the Smoothing Constant settings is the Ingress and Egress, High and Low Buffer Congestion Thresholds settings for the frame relay buffers. Refer to Figure 785-2 for instructions on setting the thresholds.
  7. Following the Congestion Threshold settings, set the Port Mode for channelized or fractional as required via the display shown in Figure 785-3.
- **Note:** Selecting Channelized options will configure the card for four ports only (1, 2, 3, and 4). Refer to Table 785-1 below for Port Level configuration options:

Table 785-1. FRS Port Configurations

MODE	PORT							
	1	2	3	4	5	6	7	8
Channelized	CH	CH	CH	CH			--	--
Fractional	FR	FR	FR	FR	FR	FR	FR	FR
Combinations	CH	CH	FR	FR			FR	FR
	FR	FR	CH	CH	FR	FR	--	--

**DLP-785**

Page 2 of 7

- ▶ **Note:** The user may not change the Port Mode if there is an existing interface configured on that port.
8. Click and drag the small block to expand the Port Level configuration section of the window.
  9. Select a Port on the simulated card by a single click on the port LED using the left mouse button. This will bring up the configuration data for that port in the Port Level section of the window. Ensure the Administrative State is set to Unlocked to enable the port for service.
  10. Set the Port Level configuration options per requirements. Refer to Table 785-2 for a list of options the user may select for this card type.
  11. Hit the **Apply** button at the bottom of the window to back up the new configuration data to the shelf controller and configure the port before attempting to create interfaces on the port.
    - ▶ **Note:** Selecting **Chassis View** will return the user to the previous window without closing the FT1 FRS window. Selecting **Refresh** will update the current window display with all the selections last recorded by the Shelf Controller card. Selecting **Close** will close this window and return the user to the Chassis View window.
  12. Double click on the port just configured (1 to 8, depending on Port Mode selected) to bring up the Frame Relay Interface screen. Refer to the example shown in Figure 785-4. Within this screen, the user may elect to change the port interface by double clicking on the port desired in the Circuit box on the left.
  13. There are 24 DS0 channels selectable for the interface in the Interface Selection block of the window. If creating a Channelized connection, the user may create up to 24 single interfaces, or multiple interfaces made up of any number of contiguous channels using this tool. If creating a Fractional connection, the user may select up to 24 channels to create a single interface one time. The system will then indicate “Interface Creation Disabled”. Select the individual or range of DS0 channels to create the first interface using the left mouse button. Click on the first channel and then on the last contiguous channel of the range. The channels will become white and are shown linked by a bracket in the window. The GUI indicates this is the number 1 interface and shows it as the “Current” selection.
  14. In the main block of the window the user can assign multiple identifiers, and configure the interface. Refer to Table 785-3 for definitions of each option. Once all interface data is entered, select the **Apply** button at the bottom of the screen to create the interface on the port.
  15. The user may now select the next channel(s) for another channelized interface and repeat step 13 or select **Close** and return to step 9 to create the next Port Level configuration. If creating another channelized interface on this port, the user will notice the color changes to blue for the next channel(s) selected and the system will number it 2 and indicate it is the “Current” channel. If multiple interfaces are displayed, the user must “double-click” on any

channel of the interface desired to make it “Current” to allow configuration changes or to delete that interface.

16. Select the *Close* button to return to the FT1 FRS card display.
17. Select the *Close* button to return to the Chassis View window.
18. Repeat steps 1 through 14 for each card in the shelf.

**Stop! You have completed this procedure.**

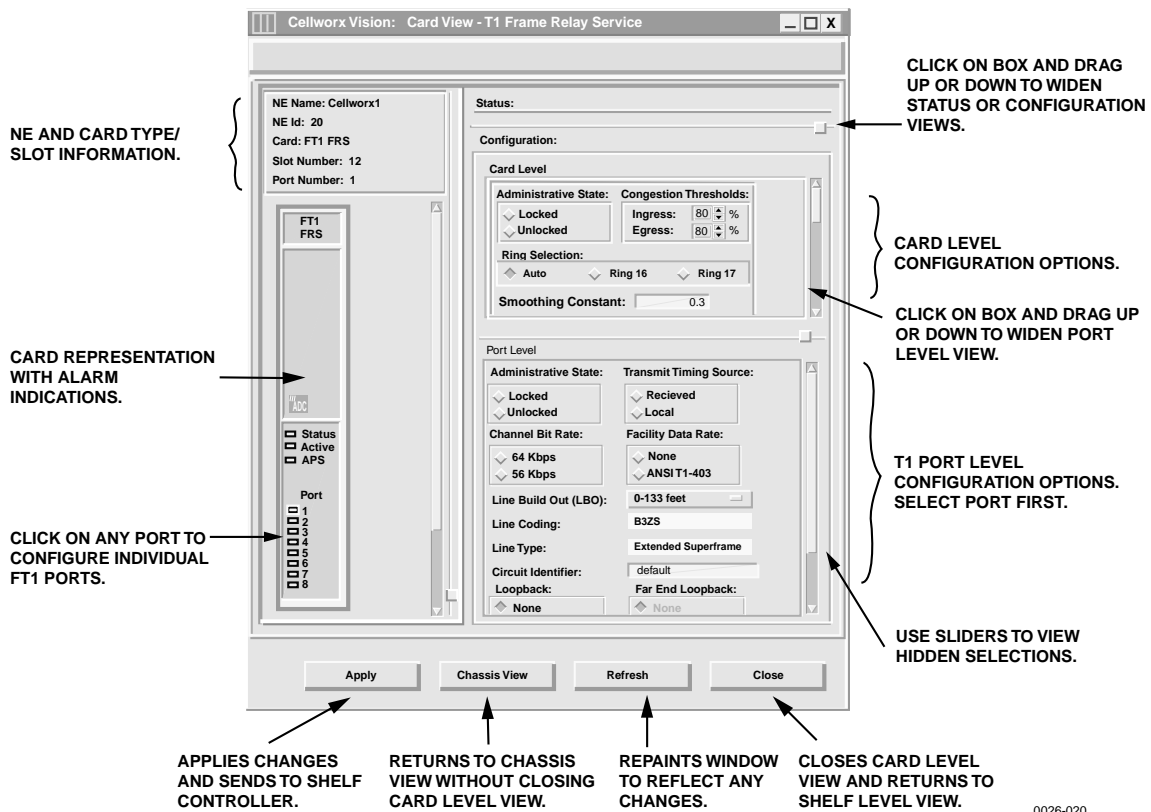
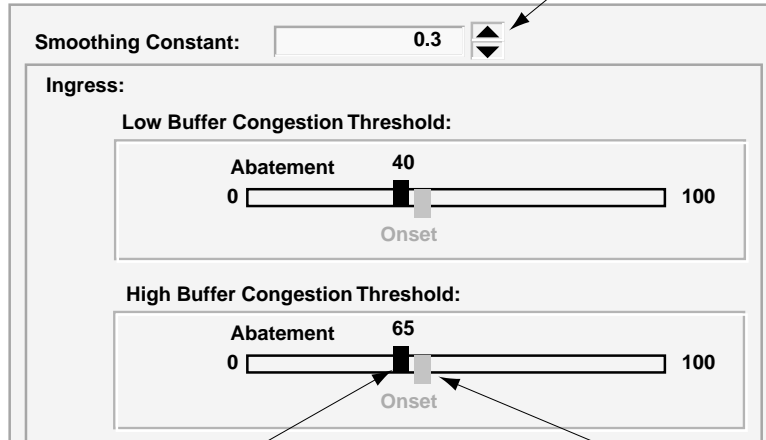

Figure 785-1. FT1 FRS Card Configuration Window

DLP-785  
Page 4 of 7

CLICK ON THE UP OR DOWN ARROWS TO INCREASE OR DECREASE THE VALUE WHICH PROVIDES EXPONENTIAL SMOOTHING FOR ALARM NOTICES THAT REPORT/RESPOND TO FR BUFFER CONGESTION



SELECT THE BLACK BLOCK AND DRAG TO THE DESIRED BUFFER CONGESTION THRESHOLD FOR ALARM ABATEMENT. THIS VALUE WILL BE 10 PERCENT LESS THAN THE THRESHOLD ONSET.

SELECT THE RED BLOCK AND DRAG TO THE DESIRED BUFFER CONGESTION THRESHOLD FOR ALARM ONSET. ANY CELLS TAGGED AS DISCARD ELIGIBLE FOR ANY INTERFACE AND PORT MAY BE DISCARDED ONCE THIS THRESHOLD IS CROSSED.

0026-001

Figure 785-2. FRS Buffer Congestion Threshold Settings

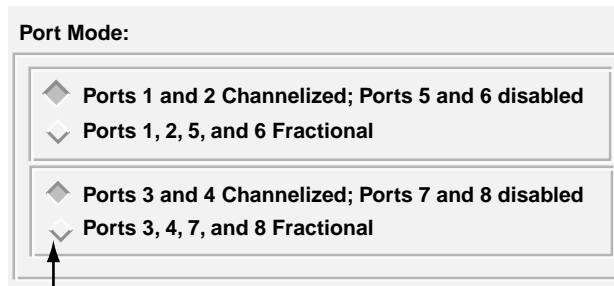

SELECT THE DESIRED PORT CONFIGURATION AND THEN HIT THE APPLY BUTTON. NOTE THAT IF SELECTING CHANNELIZED CONFIGURATION, PORTS 5 AND 6, AND/OR 7 AND 8 WILL NOT BE SELECTABLE FOR INTERFACE CONFIGURATION.

0026-021

Figure 785-3. FRS Port Mode Settings

Table 785-2. FT1 FRS Configuration Options

SELECTION	DEFAULT	OPTIONS	DEFINITIONS
Card and Port Administrative State	Unlocked	Unlocked Locked	Enables or disables card/port for service, respectively.
Congestion Threshold	80	0-100	Percentage of ingress/egress buffer capacity that will cause a congestion threshold notification.
Ring Selection	Auto	Auto Ring 16 Ring 17	Card will automatically select traffic from the ring direction with the best signal. Card will receive traffic from Ring 16 direction. Card will receive traffic from Ring 17 direction.
Low Ingress/Egress Buffer Congestion Onset/Abatement	<default>	Variable	This will cause the FECN/BECN in the frame relay header to be set or cleared. Abatement is always ten percent less than onset.
High Ingress/Egress Buffer Congestion Onset/Abatement	<default>	Variable	Exceeding threshold causes frames with DE field equal to 1 to be discarded. Frame discarding stops upon reaching abatement level. Abatement is always ten percent less than onset.
Transmit Timing Source	Local	Received Local	Incoming clock pulse used for outgoing signal. Clock pulse supplied by the SC cards used for outgoing signal.
Channel Bit Rate	64	64 56	Sets the Kilobits Per Second (Kbps) data rate for the channels provisioned on the port.
Facility Data Link	None	ANSI-T1-403 FDL None	A peer-to-peer protocol across a T1 line providing OA&M functions (performance monitoring, loop back etc.) implemented via the framing bits in the T1 frame.
Line Build Out	0-133 feet	0 – 133 ft 133 – 266 ft 266 – 399ft 399 – 533ft 533 – 655ft	Sets the signal strength according to the distance in feet that the Cellworx STN is from the T1 interfacing equipment.
Line Coding	B8ZS	Non configurable	Bit 8 Zero Substitution
Line Type	Extended Superframe	Non configurable	Extended Superframe
Circuit Identifier	<default>	Up to 20 alphanumeric characters.	User defined. Usually describes the traffic, customer, and/or channel number.

Table 785-2. FT1 FRS Configuration Options, Continued

SELECTION	DEFAULT	OPTIONS	DEFINITIONS
Loopback	None	None Facility Line  Terminal Facility Payload	No Loopback selected.  Loops frames back out to EIM after assigning overhead and buffering.  Loops ATM cells back to Cellbus.  Loops the payload back to customer interfacing equipment before assigning overhead and buffering.
Far End Loopback	None	None Line Payload  Reset	No loopback is requested.  Tells the far end to loop the line back.  Tells the far end to loop the payload after line data is extracted.  Tells the far end to stop the loopback.

**DISPLAYS NE AND CARD TYPE/SLOT INFORMATION.**

**DOUBLE-CLICK ON A PORT TO CHANGE TO THAT PORT FOR INTERFACE CONFIGURATION.**

**SELECT THE FIRST CHANNEL AND/OR THE LAST CONTIGUOUS CHANNEL TO CREATE AN INTERFACE.**

**SELECT THE APPLY BUTTON AFTER CREATING EACH INTERFACE ON THE PORT.**

**DELETES THE INTERFACE SHOWN AS "CURRENT" ABOVE.**

**RETURNS TO THE CARD VIEW.**

**REFRESHES SCREEN DATA.**

**CLOSES THE WINDOW AND RETURNS TO THE CARD VIEW WINDOW.**

The screenshot shows a window titled "Cellworx Vision: Frame Relay Interface". It contains fields for Node Name (NE-2), Slot Number (6), Node ID (4), Card (FT1 FRS), Location (Broadway), and Port Number (4). Below these are instructions: "Double click on an interface to display it. Select a channel number with the left mouse button to start channel selection. Select a channel number with the right mouse button to end channel selection. Select a port to switch ports." There is a table with Port (1-4) and Channel (X) columns. Below that is a channel selection interface with a grid of channels 1-9 and a "Current" indicator. To the right are fields for Interface Name, Interface Contact, Interface Location, Recording Interface Id, Operational Status (Up), Provisioned Endpoints (0), and DLCI Length (2 Octets 10 Bits). Further down are bandwidth settings (Ingress/Egress at 0.00%), Effective Bandwidth (100.00%), Interface Type (UNI, NNI), and IWF Type (FRF.5, FRF.8). Signaling Parameters include Signaling Protocol (None, LMI Rev1, Annex D: ANSI T1.617D, Annex A: CCITT Q). At the bottom are buttons: Apply, Delete, Card View, Refresh, and Close.

0026-012

Figure 785-4. FT1 FRS Interface Configuration Window

Table 785-3. Frame Relay Interface Configuration Options

SELECTION	DEFAULT	OPTIONS	DEFINITIONS
Interface Name	<default>	Any alphanumeric characters.	User defined. Can describe the card type, slot, port, and/or channel number, etc.
Interface Contact	<default>	Any alphanumeric characters.	User defined. Can describe the name, number etc. of contact person.
Interface Location	<default>	Any alphanumeric characters.	User defined. Can describe the location of the plant, shelf, slot, port, etc.
Recording Interface ID	All 0s	Numeric	Identifies the site card and port location for customer billing capabilities, (allows assignment of a customer ID for each port), limited to 15 numeric characters.
Operational Status	Up	Display Only	Indicates the operational status of the interface.
Provisioned Endpoints	0	Display Only	Displays how many FR endpoints are configured by administrator on this interface.
DLCI Length	2 Octets 10 Bits	Display Only	Indicates the size of the data link connection identifier assigned to this interface.
Used Bandwidth	Traffic Dependant	Display Only	Indicates a percentage of Ingress and Egress bandwidth utilized for the selected interface.
Effective Bandwidth	Traffic Dependant	Display Only	Indicates a percentage
Interface Type	UNI	UNI NNI	User to Network Interface Network to Network Interface
IWF Type	FRF.5	FRF.5 FRF.8	Frame Relay Forum standards. Frame Relay to ATM inter-working type.
Signaling Protocol	None	None LMI Rev 1 Annex D: ANSI-T1.617D Annex A: CCITT-Q933A	

**DLP-786**

Page 1 of 10

**CREATE A FRAME RELAY CONNECTION**

**Summary:** This procedure describes the steps required to provision a frame relay to frame relay (FRF.5) or frame relay to ATM VC (FRF.8) connection through the Cellworx STN network. Creating a connection entails selecting the originating and terminating NEs, cards, ports and interfaces, and assigning identifiers and traffic contract types. For ATM and CES connections, refer to DLP-708. For ATM Multicast connections, refer to DLP-787. Frame relay traffic contracts will also be discussed in this procedure. Prerequisites of establishing a connection are:

- A discovery must have been performed on the system.
- The connection endpoints hardware (cards/ports) must be provisioned and in service (unlocked) per NTP-006.

➤ **Note:** User may navigate through the GUI menus using the mouse or by using the Alt key plus the underlined letters in the menus simultaneously, and then the arrow keys to scroll up, down, or across. Refer to the Graphical User Interface Operation in Section 2 of this document.

1. There are three ways to initiate the process of establishing a connection.
  - a. Using the left mouse button, select the **Configuration** pull-down menu, click on **Connection**, and then **Create** (or press **Alt+C**, **Alt+N**, **Alt+C**.) Refer to Figure 786-1.
  - b. Using the Select tool (arrow) on the left toolbar, select the NE where the connection is originating by a click and hold on the right mouse button. A pop-up window appears as shown in Figure 786-1. Continue holding down the right mouse button and move the cursor to select **Create Connection**. Release the mouse button.
  - c. Using the left mouse button, select the connection tool on the toolbar to the left of the workspace. Click and hold the left mouse button down on the NE where the connection is originating and drag to the destination NE. A line is drawn between the two NEs as the crosshair pointer progresses. Refer to Figure 786-2.
2. The Cellworx Vision Connection Configuration window appears displaying all NEs discovered in the network in both the top section and the bottom section of the window. Refer to Figure 786-3. Ensure the originating and destination NEs are highlighted, if not, select them using the left mouse button.
3. Enter an identification for the connection in the Connection Name text box using any alphanumeric and special characters. This ID should be unique in character so the user can discern between it and other connections for management purposes. The IDs assigned here will be displayed when viewing connections. System will allow duplicate connection names but will also assign a unique ID to the connection if the user does not enter one.



4. Following the example shown in Figure 786-3, specify the connection type by left mouse clicking on the **Connection Type** pull down menu and selecting the FR connection type desired. The window displays the two FR connection types as follows:
  - FR-ATM VC
  - FR-FR
5. Using the left mouse button, select the desired NE, Slot/Card Type, and Network Interface/Interface Type for the originating and destination endpoints. Click on *Next>>* using the left mouse button.
6. For FR-FR connections, the screen shown in Figure 786-4 appears. For FR-ATM VC connections, the screen shown in Figure 786-5 appears. The two sections below the Connection Name text box of the next window represent the two connection endpoints. The network element identifications for both end points are displayed as well as the interface type. Using the left mouse button, click on the up or down arrows to select a Maximum Frame Size for this connection up to 4096 bytes.
7. On the upper FR section, select a Data Link Connection Identifier (DLCI) under the heading DLCI/NE/Rate using the left mouse button. DLCIs that are already in use will not be selectable. The NE and Rate (Kbps) fields being visible to the user indicate these are in use already. If needed, use the scroll bar to display the available DLCIs not displayed in the window.
8. To the right are the PVC Endpoint Parameter selections. Click on each box that pertains to this connection. Refer to Table 786-1 below for definitions of each parameter. The bottom section of the table defines the additional FRF.8 parameters for FR-ATM connections.
 

► **Note:** If selecting Discard Eligible (DE) Bit Tagging, the connection will be treated as NRT-VBR3 (non-real time variable bit rate level 3). If not selected, the connection will be treated as NRT-VBR2.

Table 786-1. FR Endpoint Parameter Definitions

PARAMETER	OPTION	DEFINITION
Ingress NDC	All selections are either on or off. Selecting the box turns the parameter On, indicated by the box turning dark.	Enables or disables the Network Data Collection to monitor incoming traffic of this endpoint.
Egress NDC		Enables or disables the Network Data Collection to monitor outgoing traffic of this endpoint
ATM OAM		ATM Operation Administration and Maintenance selection only valid for FR-ATM VC connections. This variable controls whether the FR endpoint should support ATM F4 OAM flows.

(continued)

## DLP-786

Page 3 of 10

Table 786-1. FR Endpoint Parameter Definitions, Continued

PARAMETER	OPTION	DEFINITION
SSCS LMI		Service Specific Convergence Sub-layer Link Management Interface used to establish a communications link between two frame relay endpoints. These are used to report connection problems to the transmitting endpoints.
DE Bit Tagging		Discard Eligible BIT Tagging is used to identify cells that are over and above the Committed Information Rate (CIR). Cells are tagged as "1" and may be discarded if system congestion occurs. Cells tagged as "0" are buffered and transmitted during system congestion. If selected, the connection will be treated as NRT-VBR3 (non-real time variable bit rate level 3). If not selected, the connection will be treated as NRT-VBR2
<b>FRF.8 PVC ENDPOINT PARAMETERS</b>		
Frame Relay to ATM Mapping	CLP=DE CLP=0 CLP=1 FECN to EFCI Mapping	FR Discard Eligible markings will be carried over to the ATM Cell Loss Priority markings. All FR frames will be tagged CLP=0. All FR frames will be tagged CLP=1 and possibly discarded in the ATM stream in the event of system congestion. Forward Explicit Congestion Notification marked FR cells will be mapped to the Explicit Forward Congestion Indicator markings in the ATM stream.
ATM to Frame Relay Mapping	DE=CLP DE=0 DE=1	ATM Cell Loss Priority markings will be carried over to the FR Discard Eligible markings. All FR frames will be tagged CLP=0. All FR frames will be tagged CLP=1 and possibly discarded in the FR stream in the event of system congestion.
Encapsulation	Transparent Translation	? ?

9. The Remote Connection Identifier (DLCI) is read only and reflects the DLCI number at the originating end of the connection. Under the Service Provider Profile heading are several blocks of information that will eventually be used for customer billing capabilities. These parameters are not yet selectable and are read only.
10. The lower section of the window displays either another FR section for FR-FR connections, or an ATM VC section for FR-ATM VC connections. For FR-FR connections, repeat steps 7 through 9 and select the *Next* button at the bottom of the window, then go to step 17, otherwise continue for FR-ATM VC connections.

## FR-ATM VC CONNECTIONS

11. The bottom section of the FR-ATM window show in Figure 786-5 displays all the parameters for the ATM half of the connection. The network element and interface identification are displayed.
12. If the connection is to be configured as a segment endpoint, select the Segment Endpoint box using the left mouse button for both the originating and destination ends. This option will enable OAM cell loopback from this point to the originating end for performance monitoring capabilities.
13. Just below the Segment Endpoint box are the Ingress and Egress NDC selections. These will enable network data collection for the inbound and/or outbound traffic.
14. Next, under the heading VPI / NE / Rate (Kbps) and VCI / NE / Rate (Kbps), select an available VPI and VCI number to be assigned for the endpoint. VPIs and VCIs with an NE and Rate displayed are already in use.
15. To the right, the Service Provider Profile is displayed. Fill in the text boxes for each of the following parameters:
  - **Remote Interface Identifier** - a fifteen-digit decimal number identifying the far end interface (UNI or B-ICI).
  - **Remote Connection Identifier** - a four-digit VPI or five digit VCI decimal number identifying the VCI and/or VPI at the remote interface.
  - **Study Indication** - select using the left mouse button. This indicates the usage information is to be generated for study purposes.
16. When all of the parameters are filled in for both the originating FR endpoint and the destination ATM VC endpoint, select the *Next* button at the bottom of the window to continue.
17. The screen shown in Figure 786-6 appears. Again the connection name assigned and the connection type selected from the previous screens are displayed. The window is divided again showing the originating and destination NEs, and the Network Interface/Interface Type and this time displays the DLCI or VCI at the end of the string. If DE Bit Tagging was selected from the previous screen under the PVC Endpoint Parameters, the Service Class Type will be NRT-VBR3. If not selected the class will be NRT-VBR2. This is not a selectable field for the FR end of the connection. The ATM VC endpoint is configurable for either VBR2 or VBR3.
18. Under the Ingress Traffic Contract heading is listed “NEW” and any existing traffic contracts. Select from an existing traffic contract if available at both ends of the connection or select NEW to create a new contract. If an existing contract is selected, click on the *Apply* button to finish configuring the connection, otherwise go to step 19. The system should respond with “Connection Configuration Successful”.

## DLP-786

Page 5 of 10

### CREATING FR TRAFFIC CONTRACTS

19. If creating a new FR traffic contract, the screen shown in Figure 786-7 appears. Here all traffic contracts configured on the system will be displayed. To create a new contract, type in the name in the box. It is suggested that the user try to make the name intuitive enough that another user might know what its purpose and data rate are by looking at the name.
20. Next select the Traffic Contract Type. For this procedure the user should select the FR, QOS Class II.
21. Next select a Committed Information Rate (CIR specified in Kbps) according to the customer contract and needs. This will be the “committed” maximum rate the network agrees to transfer under normal conditions.
22. Next select an Excessive Information Rate (EIR specified in Kbps). This is the maximum “uncommitted” rate in excess of CIR the network will attempt to transfer over a specified measurement interval.
23. Next select a Measurement Interval specified in milliseconds. This is the time over which CIR and EIR are measured.
24. Select the Tagging option box if marking the cells as DE. Selecting the tagging option will create a Service Class Type NRT-VBR3 traffic contract. Not selecting the tagging option will create a Service Class Type NRT-VBR2 traffic contract.
25. Select the **Apply** button at the bottom of the screen to complete the traffic contract configuration. The system returns to the Connection Configuration window.
26. The traffic contract just created will appear in the Ingress Traffic Contract window. Select the new traffic contract for each end of the connection via a single click using the left mouse button.
27. Select **Apply** using the left mouse button to configure the connection. If the traffic contract was not selected, a message window will appear asking the user to select a Traffic Contract first. If the connection could not be established due to other conditions, a trouble message will appear giving more specific error messages.
28. The system responds with “Subnetwork Configuration <connection name> Created Successfully”.

**Stop! You have completed this procedure.**

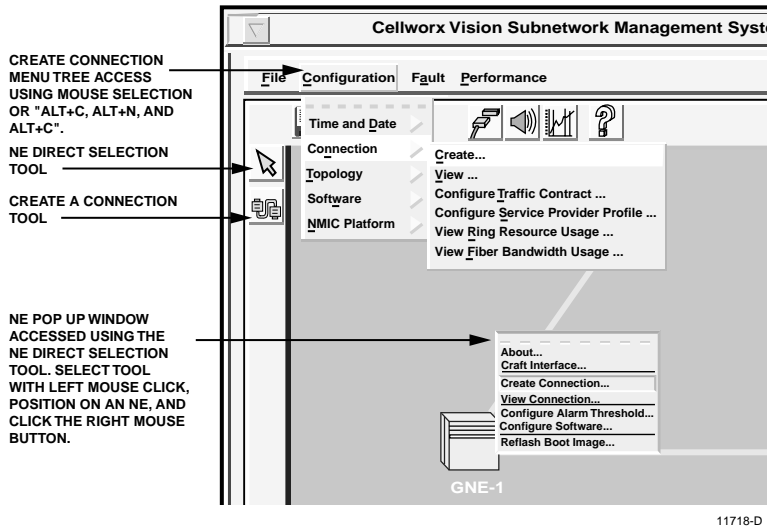

Figure 786-1. Cellworx Vision GUI Configuration Pull Down Menu

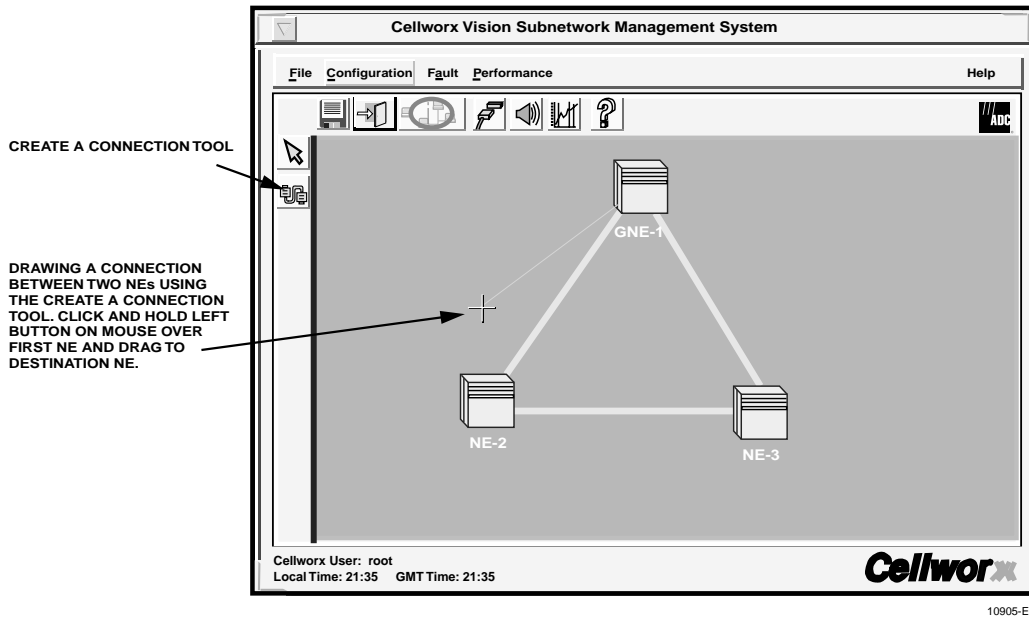
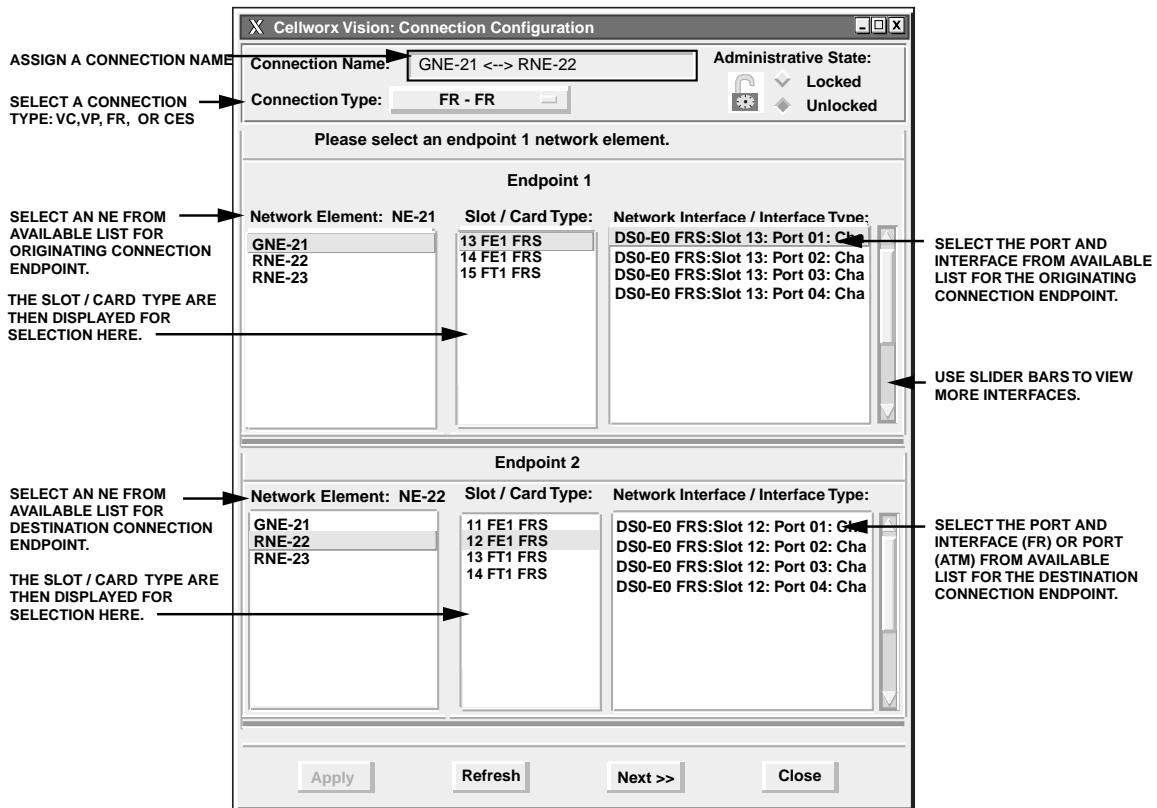

Figure 786-2. Cellworx Vision Click and Drag Connection Creation

DLP-786  
Page 7 of 10



0026-015

Figure 786-3. Connection Configuration Window

**Cellworx Vision: Connection Configuration**

Connection Name: GNE- 21 <-> RNE- 22

Administrative State: Locked / Unlocked

Connection Type: FR - FR

Maximum Frame Size: 4096 bytes

Network Element: GNE-21  
FRF.5: DS0-E0 FRS: Slot 14: Port 03: Channels 01-24

Page 1

PVC Endpoint Parameters:

- Ingress NDC
- Egress NDC
- ATM OAM
- SSCS LMI
- DE Bit Tagging

Remote Connection Identifier (DLCI) : 19

Service Provider Profile

FR Interface Identifier: 0

Study Indication

Remote Interface Type: UNI / BICI / FR UNI

DLCI / NE / Rate (Kbps):

16	/	RNE 22	/	1
17				
18				
19				
20				
21				
22				
23				

Network Element: RNE-22  
FRF.5: DS0-E0 FRS: Slot 14: Port 03: Channels 01-24

Page 1

PVC Endpoint Parameters:

- Ingress NDC
- Egress NDC
- ATM OAM
- SSCS LMI
- DE Bit Tagging

Remote Connection Identifier (DLCI) : 20

Service Provider Profile

FR Interface Identifier: 0

Study Indication

Remote Interface Type: UNI / BICI / FR UNI

<< Previous      Next >>      Close

ASSIGN A CONNECTION NAME.  
DISPLAYS CONNECTION TYPE SPECIFIED IN PREVIOUS WINDOW.  
INCREASE OR DECREASE FRAME SIZE.  
CONFIGURE ENDPOINT PARAMETERS BY CLICKING ON BOXES.  
SELECT AN OPEN DLCI NUMBER. NUMBERS WITH NE AND RATE INDICATED ARE ALREADY IN USE.  
INDICATES NE AND INTERFACE INFORMATION.  
CONFIGURE OPPOSITE ENDPOINT PARAMETERS BY CLICKING ON BOXES.  
SELECT AN OPEN DLCI NUMBER FOR OPPOSITE END OF CONNECTION. NUMBERS WITH NE AND RATE INDICATED ARE ALREADY IN USE.  
DISPLAYS SELECTED DLCI.  
DISPLAYS SELECTED DLCI.  
FUTURE USE FOR BILLING INFORMATION.  
FUTURE USE FOR BILLING INFORMATION.  
RETURNS TO PREVIOUS SCREEN TO MAKE CORRECTIONS OR CHANGES.  
CONTINUES TO NEXT SCREEN AFTER CONFIGURING THE CONNECTION ENDPOINTS.  
CLOSES SCREEN WITHOUT SAVING CHANGES.

Figure 786-4. FR-FR Connection Configuration Window

0026-016

DLP-786  
Page 9 of 10

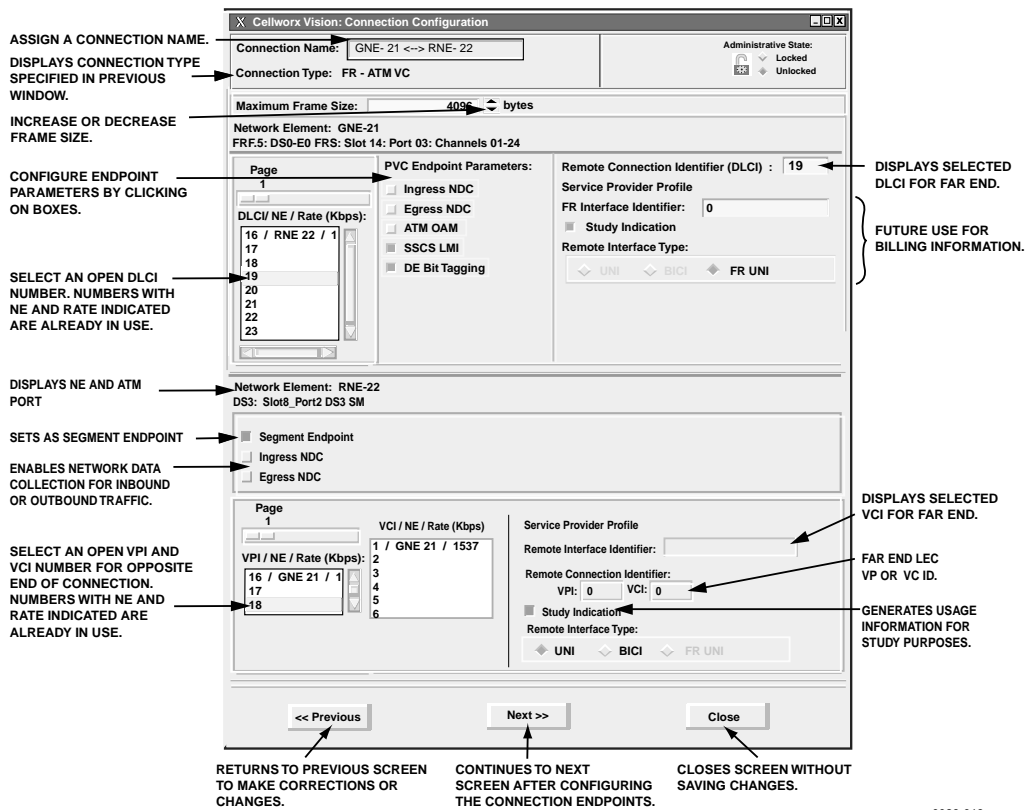

Figure 786-5. FR-ATM VC Connection Configuration Window

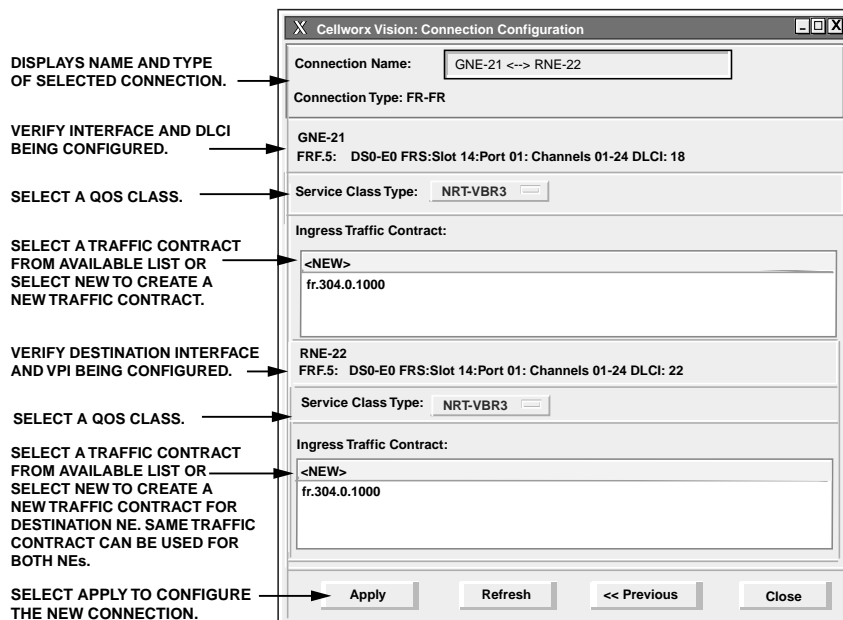
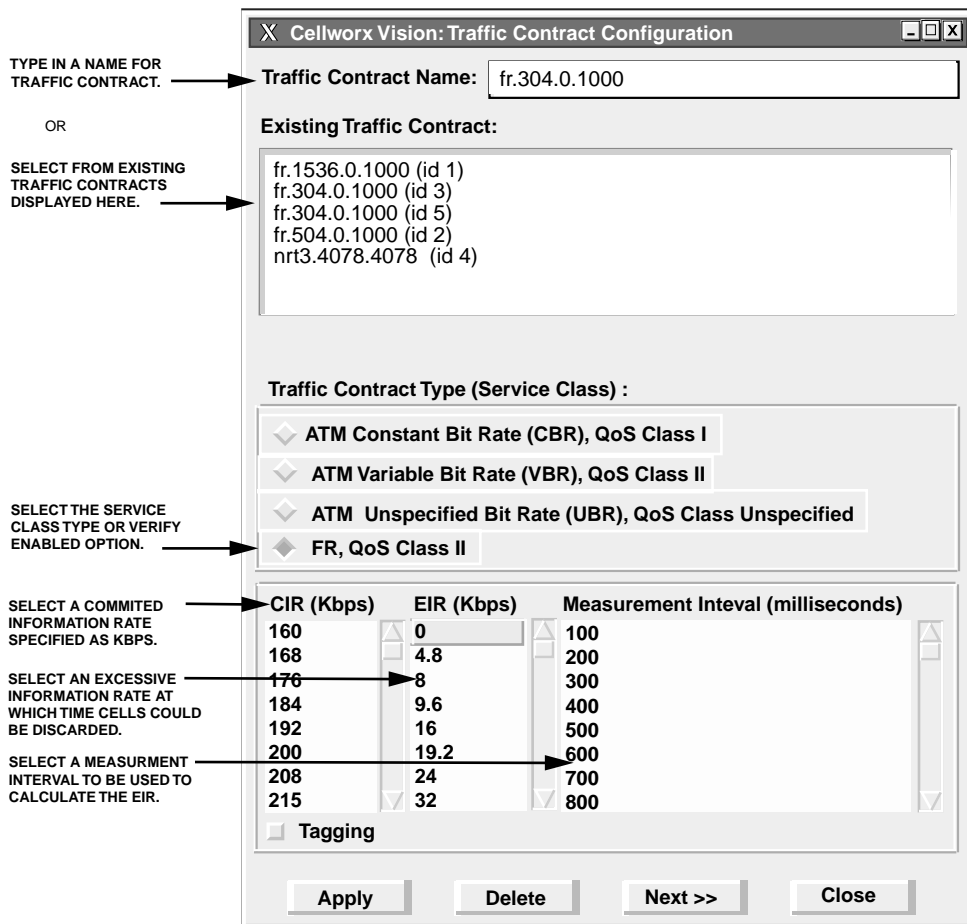

Figure 786-6 FR Connection Traffic Management Selection Window





0026-018

Figure 786-7 FR Connection Configuration - Create a Traffic Contract

**DLP-787**

Page 1 of 12

**CREATE AN ATM VP MULTICAST CONNECTION**

**Summary:** This procedure describes the steps required to provision a UBR, CBR or VBR real time or non-real time VP multicast connection through the Cellworx STN network. Creating a VP multicast connection entails selecting the originating and terminating NEs, cards, ports and interfaces. For Frame Relay connections refer to DLP-786 and for ATM Bundled VC Multicast connections, refer to DLP-790. Traffic contracts will be discussed in this procedure but performed elsewhere. Prerequisites of establishing a connection are:

- A discovery must have been performed on the system.
- The connection endpoints hardware (cards/ports) must be provisioned and in service (unlocked) per NTP-006.

◆ **Note:** User may navigate through the GUI menus using the mouse or by using the Alt key plus the underlined letters in the menus simultaneously, and then the arrow keys to scroll up, down, or across. Refer to the Graphical User Interface Operation in Section 2 of this document.

1. There are three ways to initiate the process of establishing a connection.
  - a. Using the left mouse button, select the **Configuration** pull-down menu, click on **Connection**, and then **Create** (or press **Alt+C**, **Alt+N**, **Alt+C**.) Refer to Figure 787-1.
  - b. Using the Select tool (arrow) on the left toolbar, select the NE where the connection is originating by a click and hold on the right mouse button. A pop-up window appears as shown in Figure 787-1. Continue holding down the right mouse button and move the cursor to select **Create Connection**. Release the mouse button.
  - c. Using the left mouse button, select the connection tool on the toolbar to the left of the workspace. Click and hold the left mouse button down on the NE where the connection is originating and drag to the destination NE. A line is drawn between the two NEs as the crosshair pointer progresses. Refer to Figure 787-2.
2. The Cellworx Vision Connection Configuration window appears displaying all NEs discovered in the network in both the top section and the bottom section of the window. Refer to Figure 787-3. Ensure the originating and destination NEs are highlighted, if not, select them using the left mouse button.
3. Enter an identification for the connection in the Connection Name text box using any alphanumeric and special characters. This ID should be unique in character so the user can discern between it and other connections for management purposes. The IDs assigned here will be displayed when viewing connections. The system will allow duplicate connection names but will also assign a unique ID to the connection if the user does not enter one.

4. Next specify the connection type by left mouse clicking on the **Connection Type** pull down menu and selecting **ATM VP MULTICAST**.
5. Using the left mouse button, select the desired Root Network Element, Slot/Card Type, and Network Interface/Interface Type for the originating “Root” endpoint.
6. Using the left mouse button, select the desired Leaf Network Element, Slot/Card Type, and Network Interface/Interface Type for the destination “Leaf” endpoint. After highlighting the Interface Type, select the **Add** button to define the Interface Type as a Leaf Interface. The Interface Type should now be displayed in the Leaf Interface box to the right of the screen and is removed from the available Leaf Interfaces box.
7. Multiple interface types may be selected as leaf interfaces by selecting them, clicking on the **Add** button, and moving them to the Leaf Interface box. Only one port per card is supported for release 3.1 software packages. Once all leaf interfaces are selected for the VP multicast connection, click on **Next>>** using the left mouse button.
8. The next configuration screen displays the root and leaf network elements in a split screen. Refer to Figure 787-4 for an example. At the Root Network Element upper section of the screen, select the Segment Endpoint and Ingress NDC if desired. Refer to Table 787-1 for definitions of each option selectable by the user.
9. Using the left mouse button select VPI from the list provided in the **VPI/NE/Rate** box to be utilized at the Root NE. The VPI will become highlighted. These were defined during the card interface configuration. Refer to NTP-009 for configuration procedures on each card type if needed.
10. Configure the Service Provider Profile if desired again referring to Table 787-1 for definitions.
11. At the Leaf Network Element lower section of the screen, select the **Segment Endpoint** and **Egress NDC** if desired. Refer to Table 787-1 for definitions of each option.
12. The interfaces selected from the previous screen are displayed in the “Leaf Interface” box. If they are already “configured”, they will have two asterisks preceding the identification, otherwise they may still be selected for configuration. Using the left mouse button, click on the interface to highlight it.
13. Next select a VPI interface displayed in the **VPI/NE/Rate (Kbps)** box. These were defined during the card interface configuration. Refer to NTP-009 for configuration procedures on each card type if needed. Once the VPI are selected, the Update Leaf button below becomes selectable.
14. Configure the **Service Provider Profile** if desired again referring to Table 787-1 for definitions.

**DLP-787**

Page 3 of 12

15. Click on the *Update Leaf* button to configure the leaf endpoint. The interface in the first “Leaf Interface” box will now have the asterisks before the identification string showing it as already configured. Select the next Leaf Interface to configure until all interfaces have VPI assigned. Select the *Next* button to continue.
16. The next screen allows the user to select a pre-configured traffic contract for the connection or create a new traffic contract. Refer to Figure 787-5 for an example. Select the Service Class Type by clicking on the button and selecting CBR, VBR, UBR1, RT-VBR1, 2, or 3, or NRT-VBR1, 2, or 3. Refer to Table 787-1 for definitions of these service class types.
17. Once the service class type is selected, the available traffic contracts for that type are displayed. If a contract is not available for the connection, a new one can be created by double-clicking on <New>, otherwise select the existing traffic contract, click on the *Apply* button, and go to step 25.
18. The Traffic Contract Configuration screen appears similar to the one shown in Figure 787-6. Type in a traffic contract name that will be intuitive to the user at a glance (i.e., specify the data rate in the name, etc.). Existing contracts listed in the next box may be selected to pre define the options if creating an identical contract with a different name.
19. Select a Traffic Contract Type by clicking on the desired button. Refer to Table 787-2 for all traffic contract configuration options.
20. Select a rate unit (Kpbs, Mbps) and enter the peak cell rate for the connection. This rate should not exceed the maximum data rate for any of the leaf endpoints (i.e., If the Root endpoint is a 155SM and the leaf endpoints are T3 and T1 cards, the maximum cell rate for the connection should be 1.544 Mbps as anything higher would be discarded.)
21. Enter a Cell Delay Variation Tolerance specified in microseconds.
22. Select the Sustainable Cell rate, CLP, tagging, and MBS as desired if applicable (ATM VBR QOS Class II).
23. Click on the *Apply* button using the left mouse button to create the traffic contract. The system should respond with “Traffic Contract <name of contract> created successfully.” Select the *OK* button to close the message window, and then select *Close* on the traffic contract configuration window.
24. The previous Connection Configuration window appears again displaying the Ingress Traffic Contract types. If the traffic contract just created is not displayed, ensure that the correct Service Class Type is selected. Select the traffic contract and click on the *Apply* button at the bottom of the screen.
25. The system may take several seconds to complete the connection and responds with “Configuration Successful”. Verify the connection configuration was completed by accessing the Subnetwork Connection Filter window using one of the following methods from the GUI main window:

- a. Using the left mouse button, select **Configuration, Connection, and View**. Refer to Figure 787-7.
  - b. Using the direct selection keys, enter **Alt+C, Alt+N** then **Alt+V**. Refer to Figure 787-7.
  - c. Using the right mouse button, position the cursor over the NE, click and hold the button, select **View Connections**, and release the button.
  - d. Using the left mouse button, select the connection icon above the workspace.
- 36 The Connection Filter window appears as shown in Figure 787-8. Select a topic to filter information from using the folder tabs shown. These topics allow the user to retrieve only the information desired by **Connection type, Network** available, **Traffic** contract, or **ATM** traffic by port. The user may also specify all of these by using the **All** checkbox. Refer to Table 787-3 for descriptions of each filter type. Select the **ATM VP MULTICAST** button and the **Apply** at the bottom of the screen.
- 37 The Connection List window appears as shown in the example in Figure 787-9. The list of connections can be displayed alphabetically by the connection name or by the NE name by using the **Format** pull down menu and selecting **Sort by Name**, or **Sort by NE**. The status column indicates the most current information for the connection. The status may be listed as INCOMPLETE, FUNCTIONAL, or as an UNKNOWN STATE. This screen displays up to 100 entries per page by using the up and down slide button on the right side of the window. If more than 100 entries are available for viewing, the user may use the slide bar on the right side of the window to scroll through the entries.
- 38 If a connection is displayed as INCOMPLETE, select it using the left mouse button to highlight it and then select **Retry** to attempt to establish the connection.
39. The user may delete a connection, or multiple connections, by selecting them using the left mouse button, and then selecting **Delete**. A confirmation message will appear requiring the user to select **OK** or **Cancel**. If a problem exists with the hardware between the NMIC and the endpoint shelf controllers, a denial message may appear detailing why the connection could not be deleted. Refer to DLP-713 and the trouble log for any error reports.
40. To gain status information of a certain connection, using the left mouse button the user double clicks on the connection, or single clicks to highlight the connection followed by selecting **Status** at the bottom left of the window.
41. The Connection Status window appears similar to the one shown in Figure 787-10. The connection name is displayed at the top of the window. The administrative state may show as Locked or Unlocked. Locked indicates the connection is taken down at both ends, no traffic is allowed on the ring. Unlocked indicates the connection is operable in a normal state. The user may change options on the connection by selecting **Configure**. Access to the Configure screen can also be obtained from the previous Connection List screen via the **Configure** selection button found there.

**DLP-787**

Page 5 of 12

42. The Connection Configuration screen appears. Refer to Figure 787-11. Again the connection name is displayed at the top of the window. The Root end of the connection can be taken down by changing the Administrative State to **Locked** using the button at the top right corner of the window and then selecting **Apply**. Similarly, the leaf endpoint can be locked using the feature at the bottom left of the screen.
43. Either or both ends of the connection can be configured as OAM cell segment endpoints by selecting the Segment Endpoint box displayed at each section of the screen. This functionality can be used for maintenance or troubleshooting purposes. Select **Apply** to send configuration changes to the database or close to abort any changes.
44. The “Configuration Change Completed” window appears. Select **OK**.
45. Leaves may be added to the connection using the **Add Leaf** button at the bottom of the screen. Refer to DLP-791 to add a leaf to an existing connection.

**Stop! You have completed this procedure.**

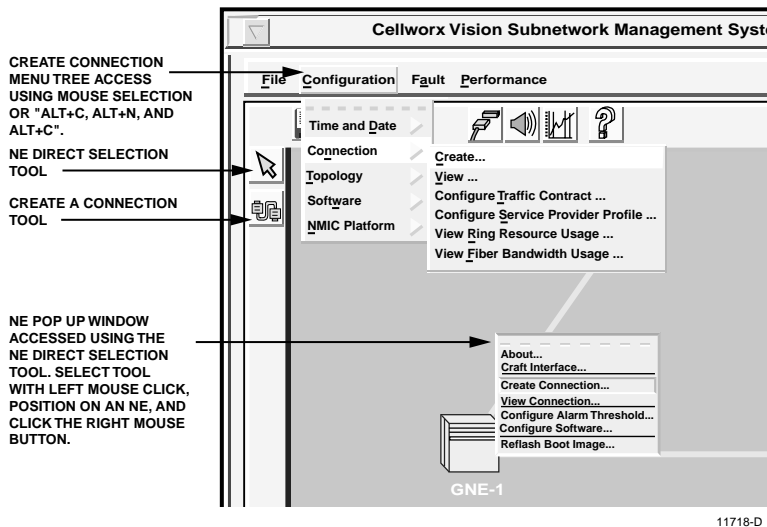

Figure 787-1. Cellworx Vision GUI Configuration Pull Down Menu

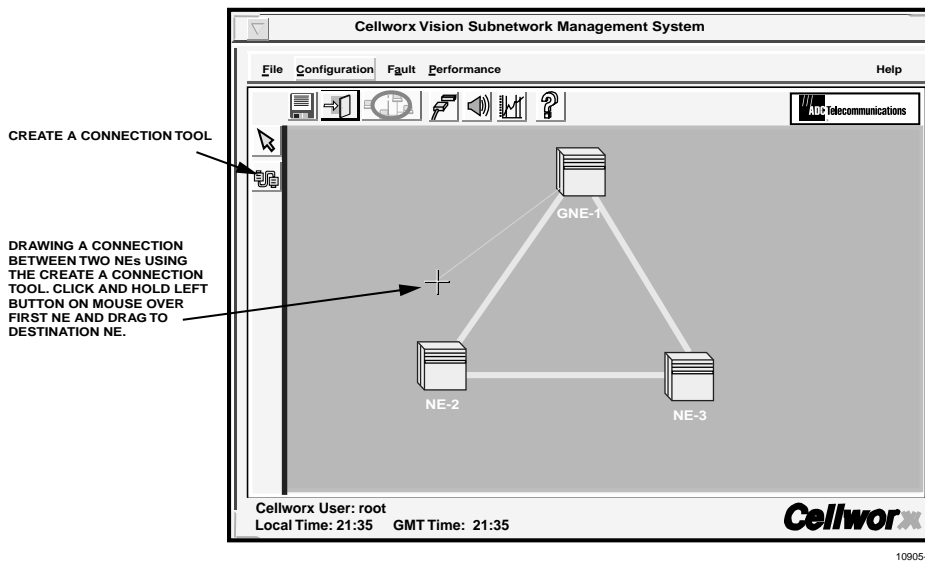

Figure 787-2. Cellworx Vision Click and Drag Connection Creation

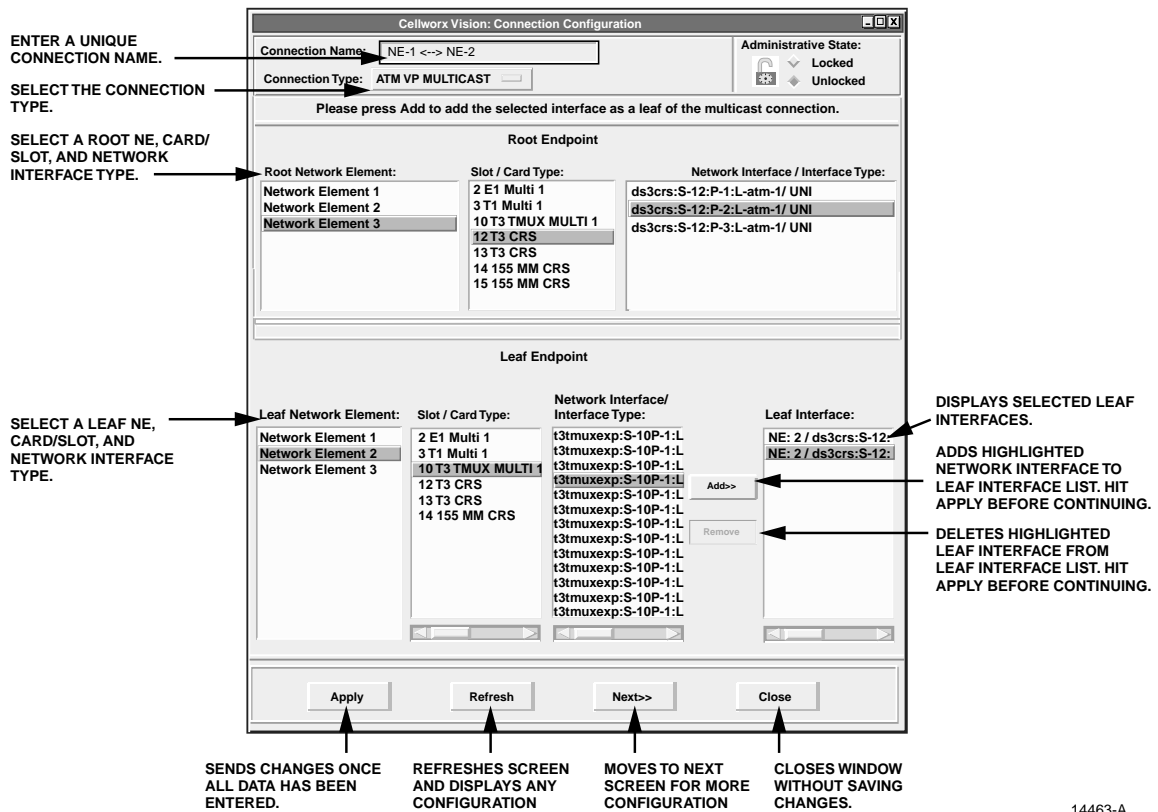

Figure 787-3. ATM VP Multicasting Configuration Screen

DLP-787  
Page 7 of 12

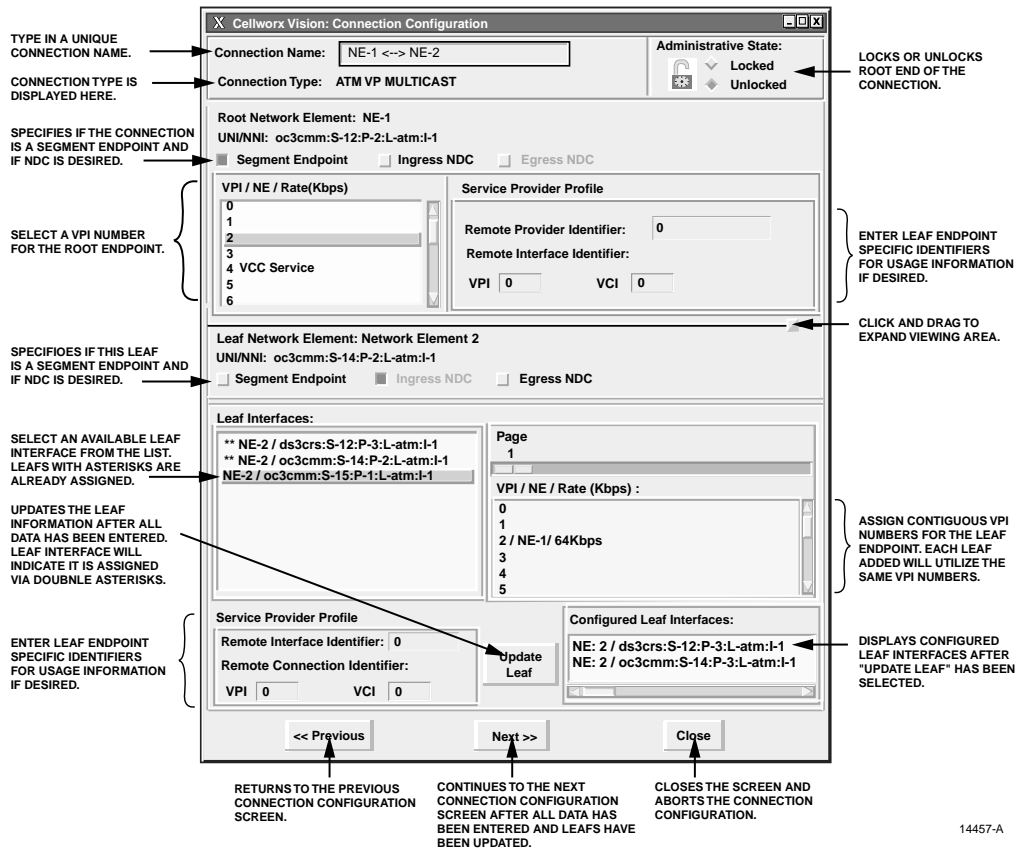
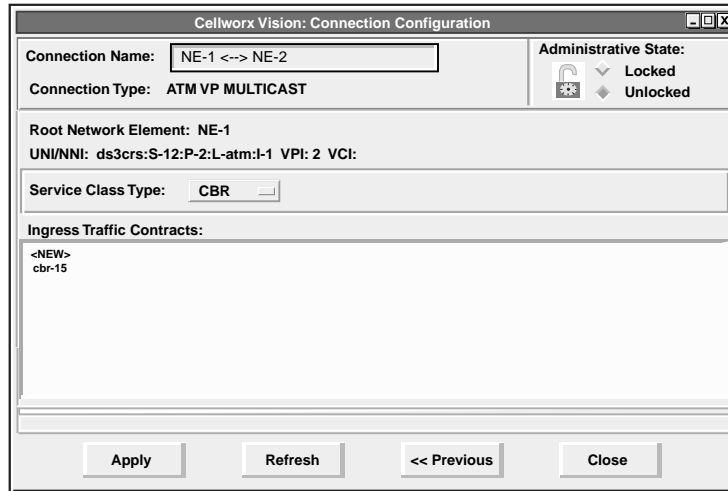

Figure 787-4. ATM VP Multicasting Configuration Window - Leaf Assignments

Table 787-1. VP Multicast Connection Configuration Options

SELECTION	OPTIONS	DESCRIPTION
Segment Endpoint	Single selection box	Sets end of connection as a segment endpoint for OAM cells.
Ingress / Egress NDC	On or Off	Enables or disables the network data collection for endpoint.
VPI/NE/Rate	User Selectable	The VPI available is determined by the card interface configuration. VPI with asterisks before them are already utilized and not selectable.
Remote Provider Identifier	User Defined	Enter alphanumeric data to help identify the far end provider interface.
Remote Interface Identifier	VPI VCI	Enter the VPI and VCI numbers to identify the remote provider circuit. This data may be utilized for usage information.
Leaf Interface	User Selectable	This list displays the configured leaf endpoints selected from the previous configuration window. Ids with asterisks before them are already utilized and not selectable.





14456-A

Figure 787-5. VP Multicast Connection Traffic Contract Selection Window

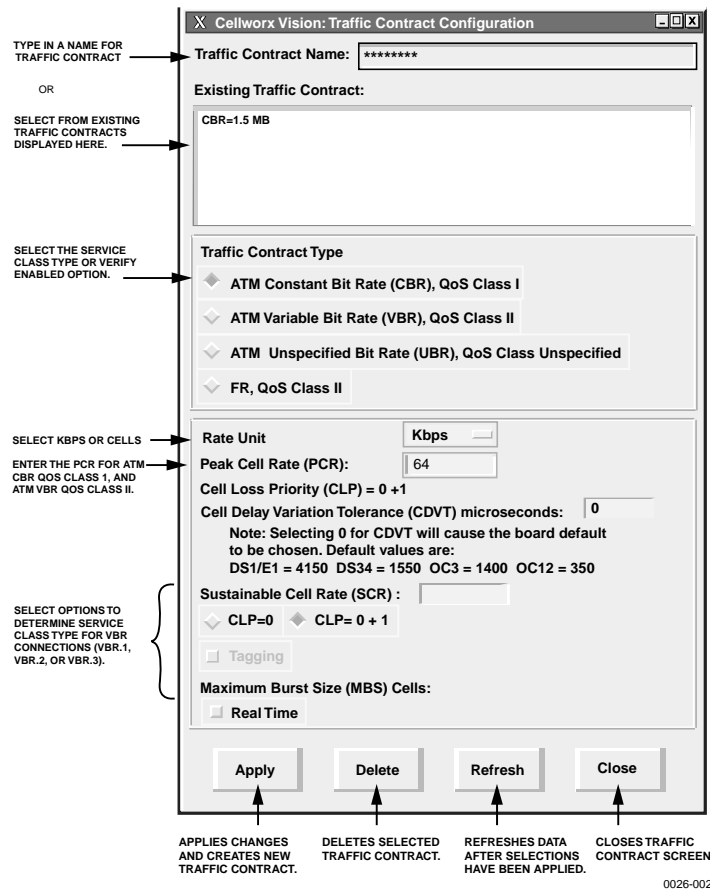

0026-002

Figure 787-6. Traffic Contract Creation Window

Table 787-2. User Selectable Service Class Types and Parameters

SERVICE CLASS TYPE	SELECTABLE PARAMETERS	COMMENTS
ATM CBR, QoS Class I	Peak Cell Rate (PCR) Kbps Cell Loss Priority (CLP) = 0 + 1	Card type and contract dependent. QoS Class I defined, not selectable.
ATM VBR, QoS Class II	Peak Cell Rate (PCR) Kbps  Sustained cell rate (SCR) Cell Loss Priority (CLP)  Tagging  Maximum Burst Size (MBS)	Card type and contract dependent, CLP always equals 0+1.  Card type and contract dependent. Determines if SCR connection is a VBR.1 (CLP=0+1) or VBR.2 (CLP=0).  Determines if SCR connection is a VBR.2 (No) or VBR.3 (Yes).  Predetermined selectable values of 32, 50, 100, 150, or 210. See note below.
ATM UBR, QoS Class Unspecified	None	No Selectable Parameters for UBR service.
Cell Delay Variation Tolerance	Specified in microseconds	User defined according to traffic contract.

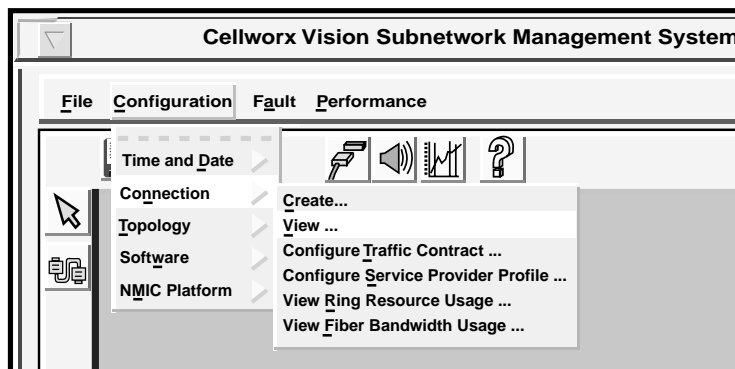

10963-D

Figure 787-7. GUI Connection Menu Tree

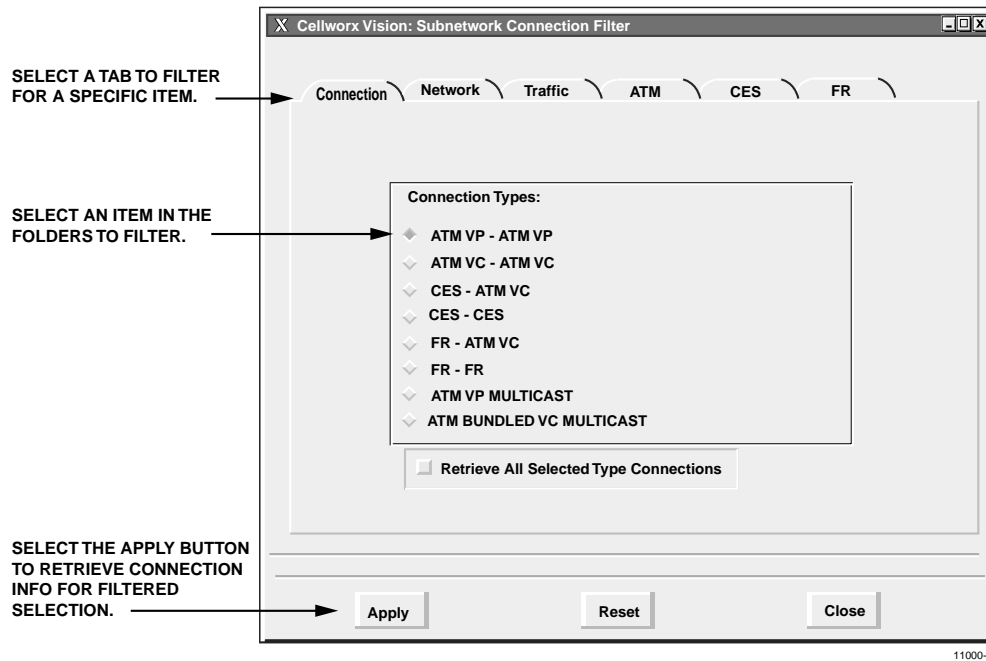

Figure 787-8 Connection Filter Window

Table 787-3. Cellworx Vision Connection Filter Descriptions

FILTER TYPE	OPTIONS	DESCRIPTION
Connection	ATM VP - ATM VP	Selects all ATM VP connections.
	ATM VC - ATM VC	Selects all ATM VC connections.
	CES - VC	Selects all Circuit Emulation Service to ATM Virtual Channel connections.
	CES - CES	Selects all Circuit Emulation Service connections (Phase II).
	FR-ATM VC FR-FR	Frame Relay not supported for Release 2.0 software packages.
Network	Administrator defined.	Allows user to specify certain NEs when filtering connections.
Traffic	Administrator defined.	Selects the traffic contract to be queried. These are user-defined names. Several connections may utilize the same traffic contract.
ATM	Administrator defined.	Selects the UNI or NNI to be queried. These are user-defined names and apply to specific ports.

DLP-787  
Page 11 of 12

USE FORMAT TO SPECIFY ORDER BY NE OR NAME, OR RETURN TO FILTER WINDOW.

USE VIEW TO DISPLAY NDC DATA.

INDICATES NUMBER OF LEAVES ON THE CONNECTION.

DISPLAYS THE STATUS OF EACH CONNECTION.

Connection Name	Root NE	Number of Leaves	Status
Broadcast-1 Uptown	NE-1	3	FUNCTIONAL
Broadcast-2 Downtown	NE-1	6	FUNCTIONAL
Video Trans-Office	NE3	2	INCOMPLETE

Buttons: Status..., Configure..., Delete, Retry, Clear Selected, Close

RETRIEVES STATUS OF SELECTED CONNECTION IN A NEW WINDOW.

BRINGS UP A CONFIGURATION WINDOW FOR SELECTED CONNECTION.

DELETES SELECTED CONNECTION.

TRIES TO COMPLETE SELECTED CONNECTION.

REMOVES HIGHLIGHT FRO SELECTED CONNECTIONS.

CLOSES WINDOW.

14466-A

Figure 787-9. ATM VP Multicast Connection List Screen

Connection Name: VP-Multicast

Connection Type: ATM VP MULTICAST

Administrative State: Locked/Unlocked

Root Network Element: NE-2

UNI/NNI: oc3cmm:S-14:P-1:L-atm:l-1

VPI: 5

VCI: 5

Administrative State: up

Traffic Contract: cbr-1.5

Leaf Endpoints:

Network Element	Interface	VPI	Status
NE-2	oc3cmm:S-11:P-2:L-atm:l-1	2	FUNCTIONAL
NE-4	ds3crs:S-8:P-1:L-atm:l-1	2	FUNCTIONAL
NE-6	t1multi1:S-14:P-5:L-atm:l-1	2	FUNCTIONAL

VCI: 32

Administrative State: up

Buttons: Configure, Refresh, Close

CONFIGURES THE SELECTED LEAF ENDPOINT.

REFRESHES STATUS INFORMATION.

CLOSES WINDOW.

14469-A

Figure 787-10. ATM VP Multicast Connection Status Window

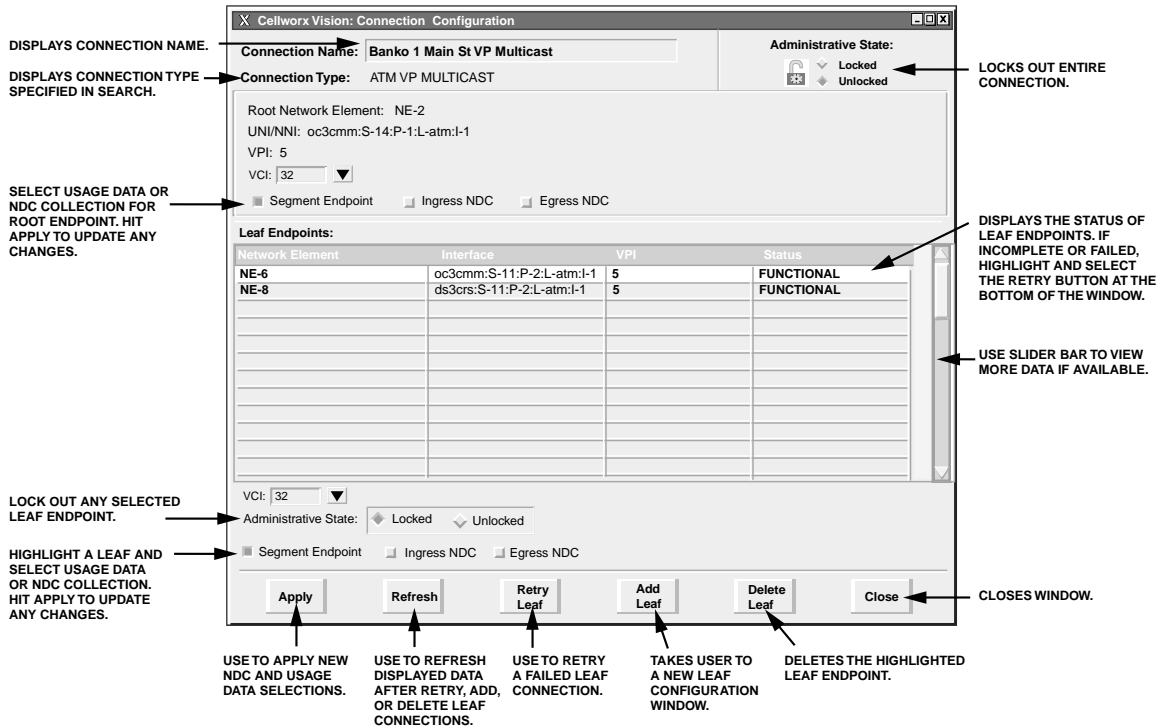

Figure 787-11. ATM VP Multicast Leaf Endpoint Status Window

## DLP-788

Page 1 of 3

## RETRIEVE FT1 FRS CARD STATUS

**Summary:** This procedure defines the information retrieved from the shelf level GUI display for the FT1 FRS card status. User must have the GUI launched and accessed the shelf level GUI display per NTP-007 prior to performing this procedure.

1. Double click on the FT1 FRS card located in the shelf level GUI “Chassis View” at the top of the window.
2. The FT1 FRS card display appears as shown in Figure 788-1. Click the small block between the Status and Configuration sections and drag it downward to view all the status information. Refer to Table 788-1 for definitions of status information provided.
3. Select each port on the card to view the port status.
4. Select *Close* button to return to the chassis level view.

**Stop! You have completed this procedure.**

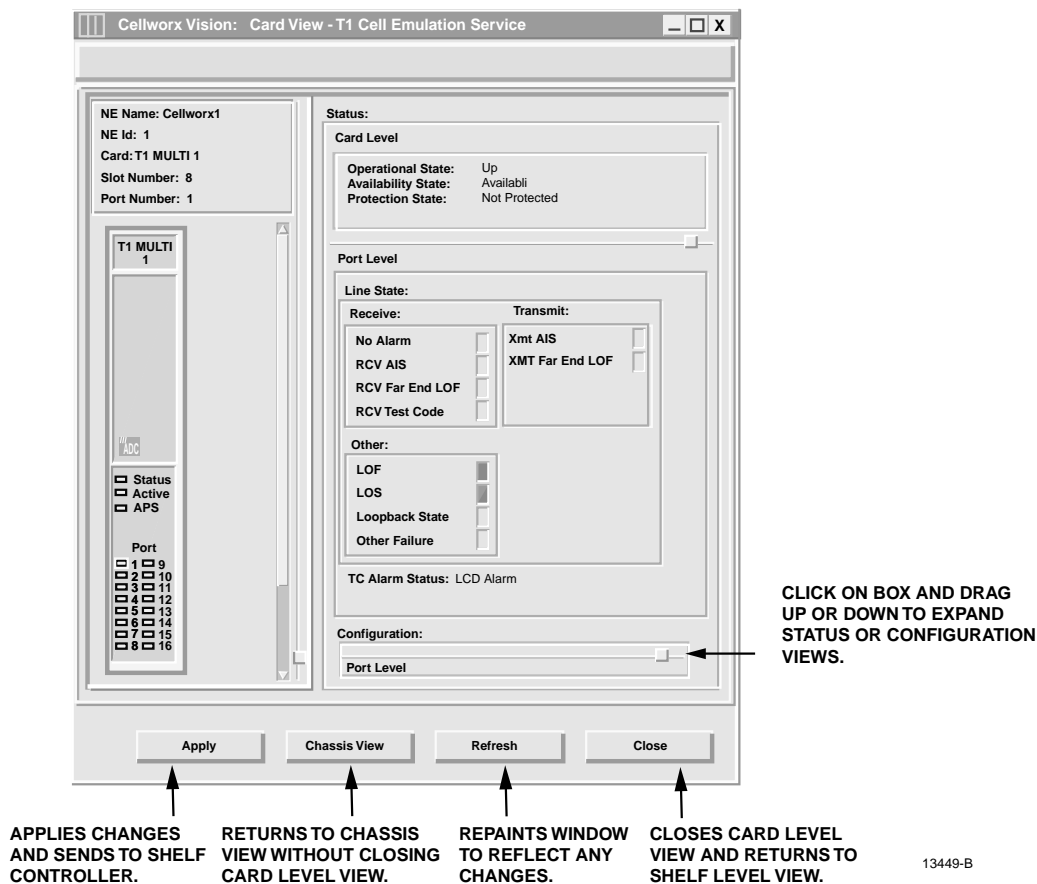

Figure 788-1. FT1 FRS Card Status Window

Table 788-1. Display FT1 FRS Card Status Definitions

ITEM	STATUS	DEFINITION	ACTION
<b>CARD LEVEL</b>			
Operational State	Up	Card is functioning properly.	No action required.
	Down	Card is not functioning properly, is in reset mode, or failed. Check Admin state.	Verify card is installed, check for failure indications, or provision card for service per DLP-785.
	Unknown	The shelf controller does not currently know the operational status.	Wait a few seconds for operations to complete and update the screen.
Availability State	Available	Card is ready for processing commands.	No action required.
	In Test	Card is currently processing test signals.	Wait a few seconds for screen to update.
	Failed	Card has failed operation and system has placed it out of service.	Card may be performing a reset, or the bus may be busy.
	Power Off	No power to the card.	Check power source, replace card if source is good per DLP-777.
	Not Installed	Card is not currently installed in selected slot of the shelf.	If required, install card in selected slot per DLP-777 and provision per DLP-785.
	Off Line	Card is installed and provisioned but currently off line.	If required, set module on line per DLP-785.
	Dependency	Card is supplying timing reference, traffic, or other data to the system.	
Protection Status	Not Protected	Not Protected	Protection operation on FRS cards is not available with release 3.1 software.
	Protected		

(continued)

**DLP-788**

Page 3 of 3

**Table 788-1. Display FT1 FRS Card Status Definitions, continued**

ITEM	STATUS	DEFINITION	ACTION
PORT LEVEL			
Line Status	No Alarm	FT1 line is operating within normal parameters.	No action required.
	RCV Far End LOF	Receive Far End Loss of Frame	Check VP connection per DLP-709, and local access interface.
	RCV AIS	Card transmitting a Remote Alarm Indication signal (RAI) to customer equipment.	Check VP connection per DLP-709, and remote transmit end.
	RCV Far End LOMF	Card receiving a Loss Of Multi-Frame indication from far end NE.	Check VP connection per DLP-709, and local access interface.
	RCV Test Code	Card is receiving a test signal input.	Check with administrator for testing activity
	XMT Far End LOF	Transmit Far End Loss of Frame	Far end NE has lost it's framing, near end is transmitting alarm back.
	XMT AIS	Card is transmitting an Alarm Indication Signal (AIS).	Check local FT1 signal input and EIM.
	LOF	Input signal frame format not recognized.	Verify correct frame format setting and signal input.
	LOS	No input signal being received.	Check signal input at EIM and DSX.
	Loopback State	Card has been manually set to loop signal back to customer equipment.	Check customer end for troubleshooting activity. If required, release loopback per DLP-772.
	Other Failure	Card is experiencing a failure other than these listed.	Take appropriate actions according to local practices.



## RETRIEVE FE1 FRS CARD STATUS

**Summary:** This procedure defines the information retrieved from the shelf level GUI display for the FE1 FRS card status. User must have the GUI launched and accessed the shelf level GUI display per NTP-007 prior to performing this procedure.

1. Double click on the FE1 FRS card located in the shelf level GUI “Chassis View” at the top of the window.
2. The FE1 FRS card display appears as shown in Figure 789-1. Click the small block between the Status and Configuration sections and drag it downward to view all the status information. Refer to Table 789-1 for definitions of status information provided.
3. Select each port on the card to view the port status.
4. Select *Close* button to return to the chassis level view.

**Stop! You have completed this procedure.**

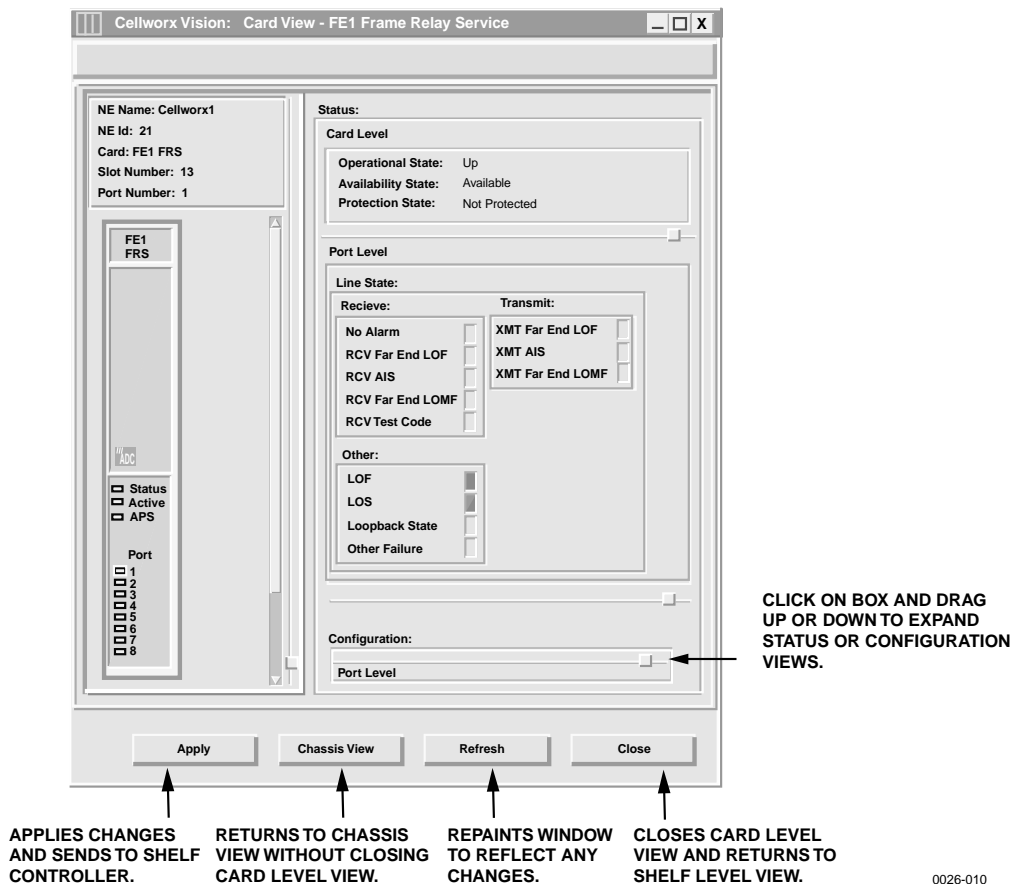

Figure 789-1. FE1 FRS Card Status Window

## DLP-789

Page 2 of 3

Table 789-1. Display FE1 FRS Card Status Definitions

ITEM	STATUS	DEFINITION	ACTION
Operational State	Up	Card is functioning properly.	No action required.
	Down	Card is not functioning properly, is in reset mode, or failed. Check Admin state.	Verify card is installed, check for failure indications, or provision card for service per DLP-784.
	Unknown	The shelf controller does not currently know the operational status.	Wait a few seconds for operations to complete and update the screen.
Availability State	Available	Card is ready for processing commands.	No action required.
	In Test	Card is currently processing test signals.	Wait a few seconds for screen to update.
	Failed	Card has failed operation and system has placed it out of service.	Card may be performing a reset, or the bus may be busy.
	Power Off	No power to the card.	Check power source, replace card if source is good per DLP-777.
	Not Installed	Card is not currently installed in selected slot of the shelf.	If required, install card in selected slot per DLP-777 and provision per DLP-784.
	Off Line	Card is installed and provisioned but currently off line.	If required, set module on line per DLP-784.
	Dependency	Card is supplying timing reference, traffic, or other data to the system.	Perform a soft switch over (manual) per DLP-771 to release card dependency if removing.
	Unknown	The system processor does not currently know the availability status.	Wait for processor to update current status, may need to perform a manual reset of SC per DLP-773.
Protection State	Not Protected	Not Protected	Protection operation on FRS cards is not available with release 3.1 software.

(continued)

Table 789-1. Display FE1 FRS Card Status Definitions, continued

ITEM	STATUS	DEFINITION	ACTION
Line State	No Alarm	FE1 line is operating within normal parameters.	No action required.
	RCV Far End LOF	Receive Far End Loss of Frame	Check connection per DLP-709, and local access interface.
	RCV AIS	Card transmitting a Remote Alarm Indication signal (RAI) to customer equipment.	Check connection per DLP-709, and remote transmit end.
	RCV Far End LOMF	Card receiving a Loss Of Multi-Frame indication from far end.	Check connection per DLP-709, and local access interface.
	RCV Test Code	Card is receiving a test signal input.	Check with administrator for testing activity.
	XMT Far End LOF	Transmit Far End Loss of Frame	Far end NE has lost it's framing, near end is transmitting alarm back.
	XMT AIS	Card is transmitting an Alarm Indication Signal (AIS).	Check local FE1 signal input and EIM.
	LOF	Input signal frame format not recognized.	Verify correct frame format setting and signal input.
	LOS	No input signal being received.	Check signal input at EIM and DSX.
	Loopback State	Card has been manually set to loop signal back to customer equipment.	Check customer end for troubleshooting activity. If required, release loopback per DLP-772. Take appropriate actions according to local practices.
Other Failure	Card is experiencing a failure other than these listed.		

**DLP-790**

Page 1 of 14

**CREATE AN ATM VC BUNDLED MULTICAST CONNECTION**

**Summary:** This procedure describes the steps required to provision a UBR, CBR or VBR real time or non-real time VC bundled multicast connection through the Cellworx STN network. Multicasting is an extension of point to point CRS which allows the user to establish uni-directional PVCs to transport ATM cells across the Cellworx ring from one NE (called root) to one or more NEs (called leaves). Creating a VC multicast connection entails selecting the originating and terminating NEs, cards, ports and interfaces. For Frame Relay connections refer to DLP-786 and for ATM VP Multicast connections, refer to DLP-787. Traffic contracts will also be covered in this procedure. Prerequisites of establishing a connection are:

- A discovery must have been performed on the system.
- The connection endpoints hardware (cards/ports) must be provisioned and in service (unlocked) per NTP-006.

► **Note:** User may navigate through the GUI menus using the mouse or by using the Alt key plus the underlined letters in the menus simultaneously, and then the arrow keys to scroll up, down, or across. Refer to the Graphical User Interface Operation in Section 2 of this document.

1. There are three ways to initiate the process of establishing a connection.
  - a. Using the left mouse button, select the *Configuration* pull-down menu, click on *Connection*, and then *Create* (or press *Alt+C*, *Alt+N*, *Alt+C*.) Refer to Figure 790-1.
  - b. Using the Select tool (arrow) on the left toolbar, select the NE where the connection is originating by a click and hold on the right mouse button. A pop-up window appears as shown in Figure 790-1. Continue holding down the right mouse button and move the cursor to select *Create Connection*. Release the mouse button.
  - c. Using the left mouse button, select the connection tool on the toolbar to the left of the workspace. Click and hold the left mouse button down on the NE where the connection is originating and drag to the destination NE. A line is drawn between the two NEs as the crosshair pointer progresses. Refer to Figure 790-2.
2. The Cellworx Vision Connection Configuration window appears displaying all NEs discovered in the network in both the top section and the bottom section of the window. Refer to Figure 790-3. Ensure the originating and destination NEs are highlighted, if not, select them using the left mouse button.
3. Enter an identification for the connection in the Connection Name text box using any alphanumeric and special characters. This ID should be unique in character so the user can discern between it and other connections for management purposes. The IDs assigned here will be displayed when viewing connections. The system will allow duplicate connection names but will also assign a unique ID to the connection if the user does not enter one.

4. Next specify the connection type by left mouse clicking on the **Connection Type** pull down menu and selecting **ATM VC BUNDLED MULTICAST**.
5. Using the left mouse button, select the desired Root Network Element, Slot/Card Type, and Network Interface/Interface Type for the originating “Root” endpoint.
6. Using the left mouse button, select the desired Leaf Network Element, Slot/Card Type, and Network Interface/Interface Type for the destination “Leaf” endpoint. After highlighting the Interface Type, select the **Add** button to define the Interface Type as a Leaf Interface. The highlighted interface should now be displayed in the Leaf Interface box to the right of the screen, and the interface card is removed from the Slot/Card Type box.
7. Multiple interface types may be selected as leaf interfaces by selecting them and clicking on the **Add** button to move them to the Leaf Interface box. Only one interface may be utilized per card for release 3.1 software packages. Once all leaf interfaces are selected for the VC bundled multicast connection, click on **Apply** using the left mouse button.
  - ◆ **Note:** If an interface was inadvertently selected as a Leaf Interface, it may be removed from the Leaf Interface box by highlighting it and clicking on the **Delete** button.
8. The next configuration screen displays the root and leaf network elements in a split screen. Refer to Figure 790-4 for an example. At the upper section of the screen, select the Root Network Element **VPI/NE/Rate (Kbps)** to be utilized by using the left mouse button to click on and highlight the VPI number. VPIs with asterisks in front of them have already been utilized.
9. Next select the VCI numbers in the **VCI/NE/Rate (Kbps)** box. These VCI were defined during the card interface configuration. Refer to NTP-009 for card configuration procedures if needed. Multiple VCIs may be selected (must be contiguous) by clicking on the first VCI selection and dragging to the last one. The user may opt to click on the first VCI, hold the shift key, and click on the last VCI to select multiple selections. VCIs with asterisks in front of them have already been utilized. These VCIs will be transported within the VPI selected. The quantity of VCIs selected must match the Leaf VCI quantity.
10. Once the Root VCIs are selected, the leaf interfaces become selectable at the lower section of the screen. Use the left mouse button to select them. These define each interface within the network where the Root VPI will terminate. If the leaf interfaces are already “configured”, they will have two asterisks preceding the interface identification, otherwise they may still be selected for configuration. Click on the interface to highlight it.
11. Next select a VPI interface displayed in the VPI/NE/Rate (Kbps) box. The number of VPIs for this port should have been configured at the port level during card interface configuration. Refer to NTP-009 for card configuration procedures if needed.
12. Next select the VCI numbers for the leaf interfaces in the VCI/NE/Rate (Kbps) box. Multiple VCIs may be selected but must be contiguous. VCIs with asterisks in front of them have already been utilized. These VCIs will be duplicated for each leaf interface

**DLP-790**

Page 3 of 14

configured. The quantity of VCIs selected must match the Root VCI quantity or an error message will appear asking the user to select the same quantity of VCIs selected at the root endpoint.

13. Click on the **Update Leaf** button to configure the leaf endpoint. The Leaf interface in the first box will now have the asterisks before the definition string showing it is already configured. It should now be observed in the Configured Leaf Interface box. If a leaf was misconfigured, highlight it in the Configured Leaf Interface box and click on **Reset Leaf** to remove it and start over, otherwise, select the next leaf interface to configure. When selecting the VCIs for the second and consecutive leaf endpoints, the VCI numbers must be identical (ex. all leaves use VCI numbers 32 through 36 on a multi-point connection).
14. Once all the Leaf interfaces are configured, select the **Next** button to continue
  - ▶ **Note:** If the user tries to select the **Next>>** button before configuring all the leaf interfaces, an error message appears.
15. The next window appears and allows the user to create a VCI “translation” from the Root to the Leaf Endpoint. Refer to Figure 790-5. Select the Root VCI number using the drop down arrow and then the Leaf VCI below it.
16. Select the >> button to map the VCIs and verify they are moved to the Selected Translation box to the right. The user may opt not to mix the VCI translation by just selecting the >> button multiple times to move each VCI to the translation box for a one to one match up. If the VCIs desired are not displayed, the user may use the <<**Previous** button at the bottom of the window to return to the previous configuration screen to reallocate the VCI numbers being utilized.
17. Once all VCIs are mapped in the Selected Translation box, use the left mouse button to select the **Next>>** button at the bottom of the window.
18. The next screen appears allowing the user to specify the usage information (NDC) and service provider information for each VCI. Refer to Figure 790-6. Select the Root VCI being configured by left mouse clicking on the down arrow and selecting a VCI from the list.
19. Select the Segment Endpoint and Ingress NDC boxes if desired. Refer to Table 790-1 for definitions of each option for Service Provider and network data collection information.
20. Select a Leaf Interface from the list provided at the lower half of the window. Select the Root VCI being configured by left mouse clicking on the down arrow and selecting a VCI from the list.
21. Select the configuration options as needed for the VCI using Table 790-1 as a reference. Configure each leaf interface and each VCI number. Once completed, select the **Next>>** button at the bottom of the window to continue to the next configuration window.

22. The next screen allows the user to select a pre-configured traffic contract for the connection or create a new traffic contract. Refer to Figure 790-7 for an example. Select the Service Class Type by clicking on the button and selecting CBR, UBR, UBR1, NRT-VBR1, 2, or 3. Refer to Table 790-1 for definitions of these service class types.
23. Once the service class type is selected, the available traffic contracts for that type are displayed in the Ingress Traffic Contract box. Select the Root VC to assign a traffic contract from the list provided.
24. If a usable contract is not available for the connection, a new one can be created by double-clicking on *<New>*. If creating a new contract, go to step 28, otherwise continue. Select an existing traffic contract from the list provided.
25. Using the left mouse button, click on the *Update Leaf* box to assign the interface a traffic contract. It should now be observed in the Configured Root VCs box to the right. The Root VC box on the left will show the interface has now been configured by displaying two asterisks before the root VC id. To remove the traffic contract/Root VC configuration, left mouse click on the configured root VC to highlight it and select the *Reset Root* button.
26. Assign the traffic contracts for each root VC. Multiple root VC ids may be selected simultaneously by a left mouse click and hold on the first VC, then drag to the last VC. The user may also click on the first VC, then hold the shift key down and select the last VC of the range.
27. Click on the *Apply* button to configure the connection. The system takes several seconds to complete the connection mapping. Once completed it will respond with "Configuration Successful". Click on the *Close* button to close the configuration window and return to the GUI main screen. Go to step 45.
28. The Traffic Contract Configuration screen appears similar to the one shown in Figure 790-8. Type in a traffic contract name that will be intuitive to the user at a glance (i.e., specify the data rate in the name, etc.). Existing contracts listed in the next box may be selected to pre-define the options if creating an identical contract with a different name.
29. Select a Traffic Contract Type by clicking on the desired button. Refer to Table 790-2 for all traffic contract configuration options.
30. Select a rate unit (Kpbs, Mbps) and enter the peak cell rate for the connection. This rate should not exceed the maximum data rate for any of the leaf endpoints (i.e., If the Root endpoint is a 155SM and the leaf endpoints are T3 and T1 cards, the maximum cell rate for the connection should be 1.544 Mbps as anything higher would be discarded.)
31. Enter a Cell Delay Variation Tolerance specified in microseconds.

**DLP-790**

Page 5 of 14

32. Select the Sustainable Cell rate, CLP, tagging, and MBS as desired if applicable (ATM VBR QOS Class II).
33. Click on the **Apply** button using the left mouse button to create the traffic contract. The system should respond with “Traffic Contract <name of contract> created successfully.” Select the **OK** button to close the message window, and then select **Close** on the traffic contract configuration window.
34. The previous Connection Configuration window appears again displaying the Ingress Traffic Contract types. If the traffic contract just created is not displayed, ensure that the correct Service Class Type is selected. Select the traffic contract and click on the **Apply** button at the bottom of the screen.
35. The system may take several seconds to complete the connection and responds with “Configuration Successful”. Verify the connection configuration was completed by accessing the Subnetwork Connection Filter window using one of the following methods from the GUI main window:
  - a. Using the left mouse button, select **Configuration, Connection, and View**. Refer to Figure 790-9.
  - b. Using the direct selection keys, enter **Alt+C, Alt+N** then **Alt+V**. Refer to Figure 790-9.
  - c. Using the right mouse button, position the cursor over the NE, click and hold the button, select **View Connections**, and release the button.
  - d. Using the left mouse button, select the connection icon above the workspace.
36. The Connection Filter window appears as shown in Figure 790-10. Select a topic to filter information from using the folder tabs shown. These topics allow the user to retrieve only the information desired by **Connection** type, **Network** available, **Traffic** contract, or **ATM** traffic by port. The user may also specify all of these by using the **All** checkbox. Refer to Table 790-2 for descriptions of each filter type. Select the **ATM BUNDLED VC MULTICAST** button and the **Apply** at the bottom of the screen.
37. The Connection List window appears as shown in the example in Figure 790-11. The list of connections can be displayed alphabetically by the connection name or by the NE name by using the **Format** pull down menu and selecting **Sort by Name**, or **Sort by NE**. The status column indicates the most current information for the connection. The status may be listed as INCOMPLETE, FUNCTIONAL, or as an UNKNOWN STATE. This screen displays up to 100 entries per page by using the up and down slide button on the right side of the window. If more than 100 entries are available for viewing, the user may use the slide bar on the right side of the window to scroll through the entries.
38. If a connection is displayed as INCOMPLETE, select it using the left mouse button to highlight it and then select **Retry** to attempt to establish the connection.



39. The user may delete a connection, or multiple connections, by selecting them using the left mouse button, and then selecting **Delete**. A confirmation message will appear requiring the user to select **OK** or **Cancel**. If a problem exists with the hardware between the NMIC and the endpoint shelf controllers, a denial message may appear detailing why the connection could not be deleted. Refer to DLP-713 and the trouble log for any error reports.
40. To gain status information of a certain connection, the user double clicks on the connection using the left mouse button, or single clicks to highlight the connection followed by selecting **Status** at the bottom left of the window.
41. The Connection Status window appears similar to the one shown in Figure 790-12. The connection name is displayed at the top of the window. The administrative state may show as Locked or Unlocked. Locked indicates the connection is taken down at both ends, no traffic is allowed on the ring. Unlocked indicates the connection is operable in a normal state. The user may change options on the connection by selecting **Configure**. Access to the Configure screen can also be obtained from the previous Connection List screen via the **Configure** selection button found there.
42. The Connection Configuration screen appears. Refer to Figure 790-13. Again the connection name is displayed at the top of the window. The Root end of the connection can be taken down by changing the Administrative State to **Locked** using the button at the top right corner of the window and then selecting **Apply**. Similarly, the leaf endpoint can be locked using the feature at the bottom left of the screen.
43. Either or both ends of the connection can be configured as OAM cell segment endpoints by selecting the Segment Endpoint box displayed at each section of the screen. This functionality can be used for maintenance or troubleshooting purposes. Select **Apply** to send configuration changes to the database or close to abort any changes.
44. The “Configuration Change Completed” window appears. Select **OK**.
45. Leaves may be added to the connection using the **Add Leaf** button at the bottom of the screen. Refer to DLP-791 to add a leaf to an existing connection.

**Stop! You have completed this procedure.**

DLP-790  
Page 7 of 14

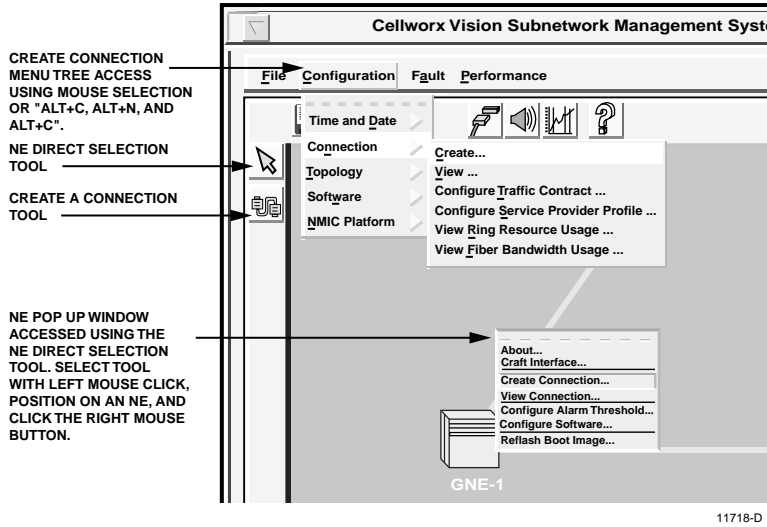

Figure 790-1. Cellworx Vision GUI Configuration Pull Down Menu

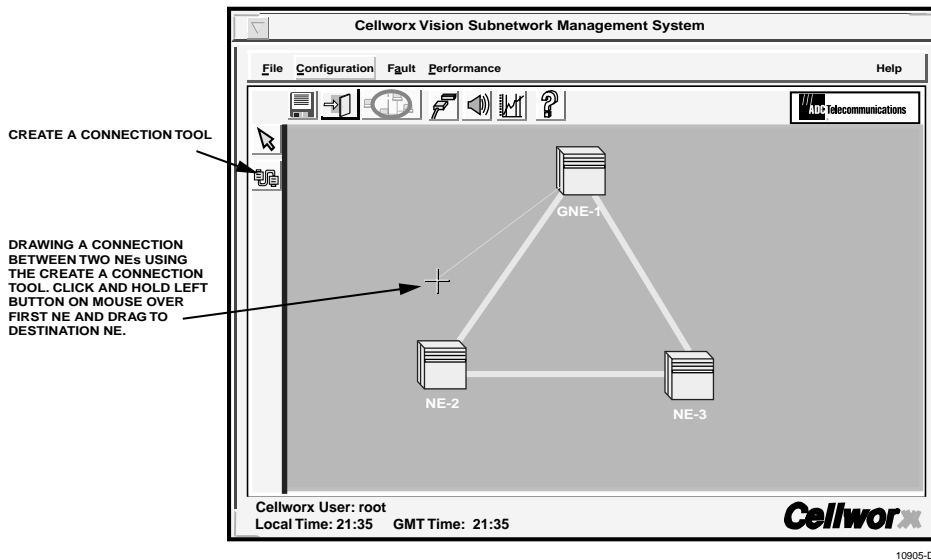

Figure 790-2. Cellworx Vision Click and Drag Connection Creation

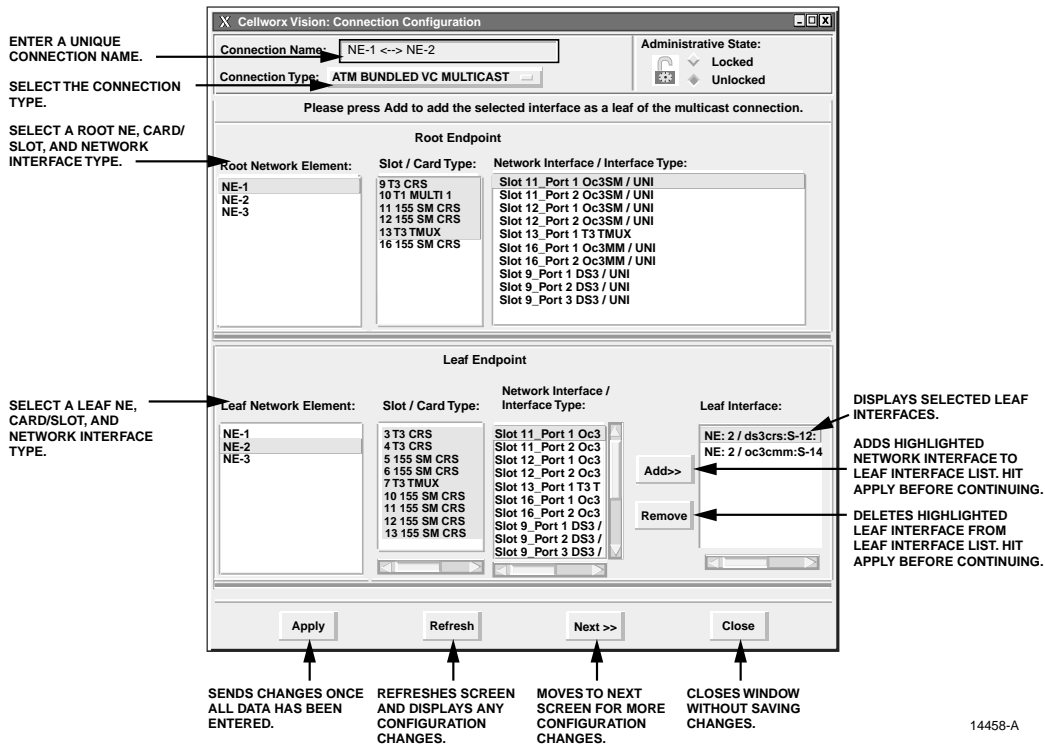

Figure 790-3. ATM VC Bundled Multicasting Configuration Screen

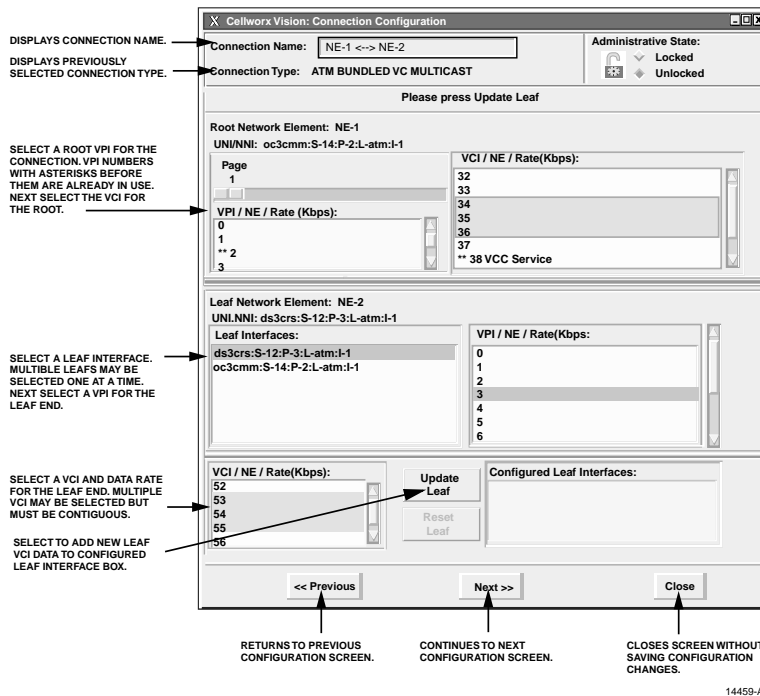

Figure 790-4. ATM VC Bundled Multicasting VCI Configuration Screen

DLP-790  
Page 9 of 14

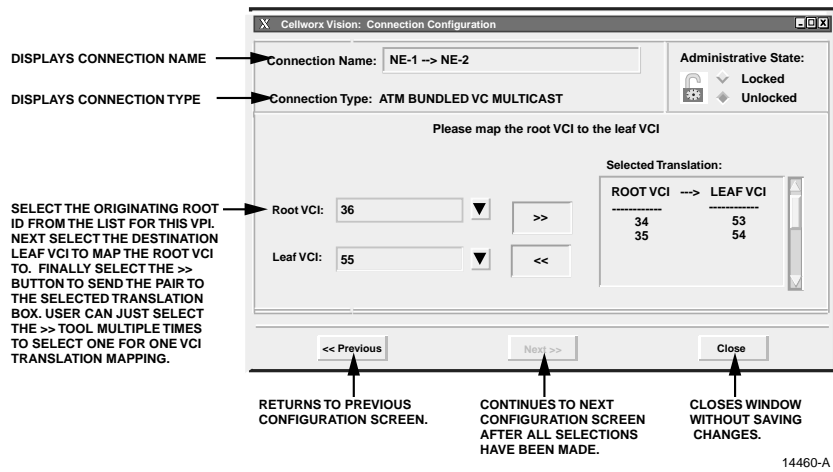

Figure 790-5. ATM VC Bundled Multicasting VCI Mapping

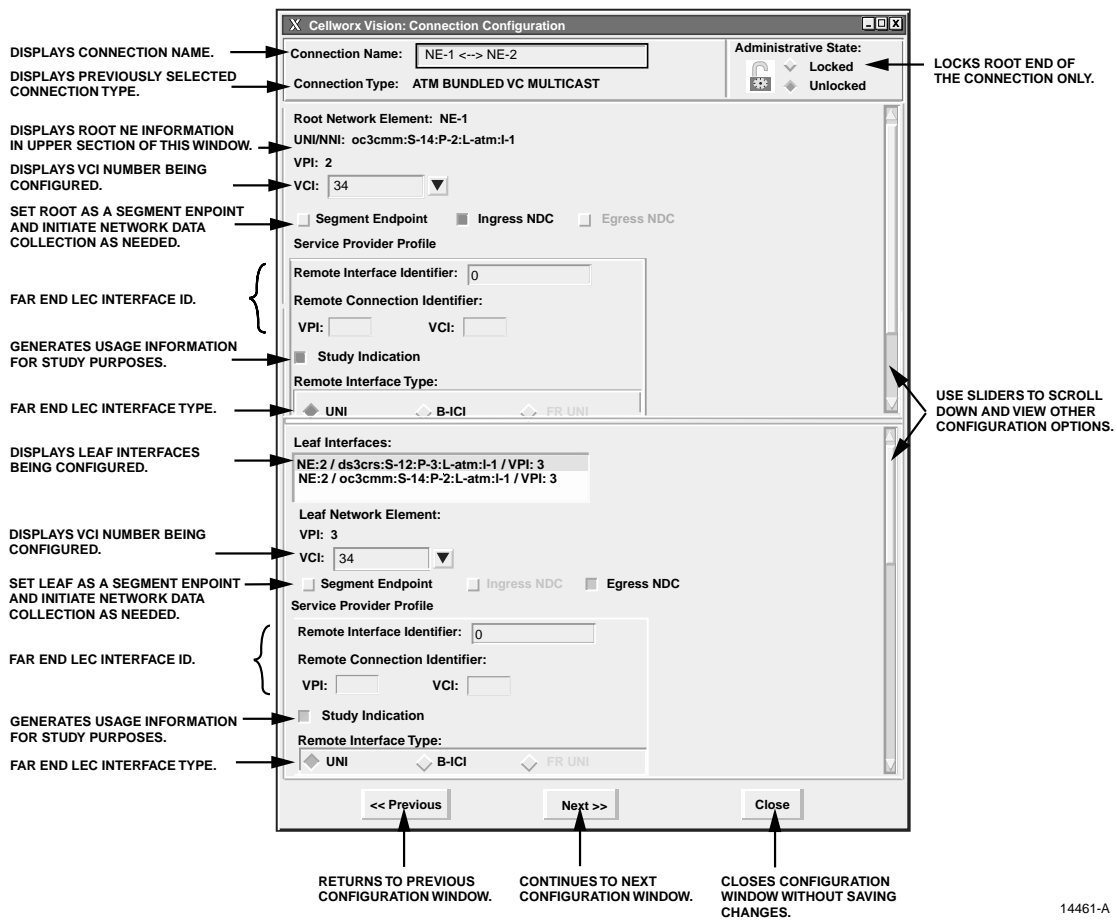

Figure 790-6. ATM VC Bundled Multicast Connection Configuration

Table 790-1. Sub-network Connection Configuration Options

SELECTION	OPTIONS	DESCRIPTION
VCI	User Defined	Virtual Connection Identifier numbers defined during card interface configuration. Refer to NTP_009 for card configuration procedures if needed.
Segment Endpoint	Single selection box	Sets this end of the connection as a segment endpoint for OAM cells.
Ingress / Egress NDC	On or Off	Enables or disables the network data collection for selected circuit.
Remote Provider Identifier	User Defined	Enter alphanumeric data to help identify the far end provider interface.
Remote Interface Identifier	VPI VCI	Enter the VPI and VCI numbers to identify the remote provider circuit. This data may be utilized for usage information.
Study Indication	On or Off	Generates usage information for study purposes.
Remote Interface Type	UNI B-ICI	User to Network Interface Broadband- Inter-Exchange Carrier Interface
Leaf Interface	User Selectable	This list displays the configured leaf endpoints selected from the previous configuration window. Ids with asterisks before them are already utilized and not selectable.

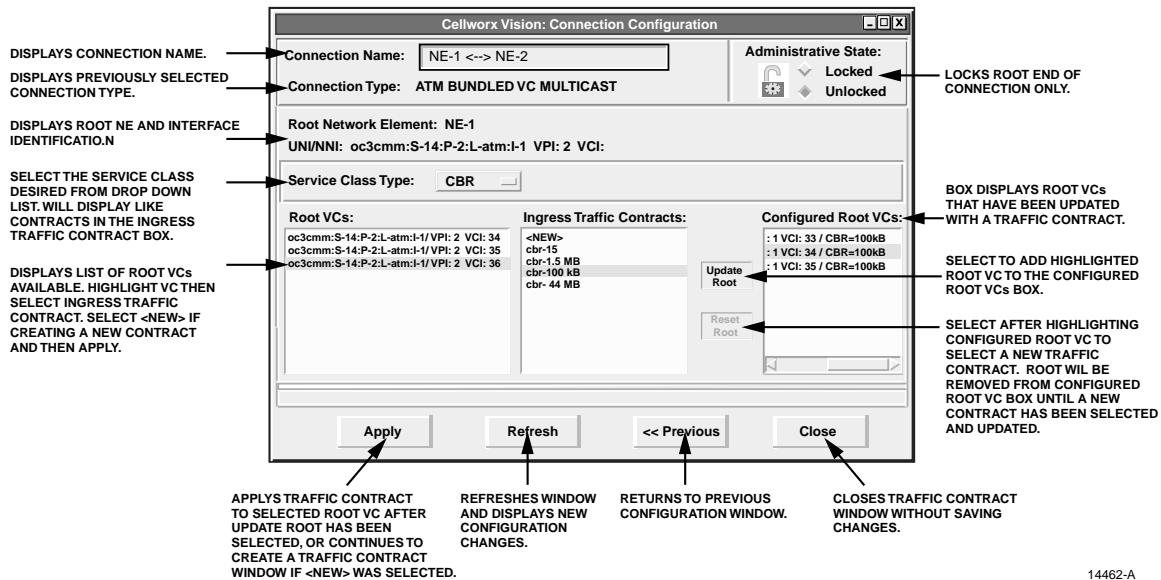

Figure 790-7. ATM VC Bundled Multicasting Traffic Contract

DLP-790  
Page 11 of 14

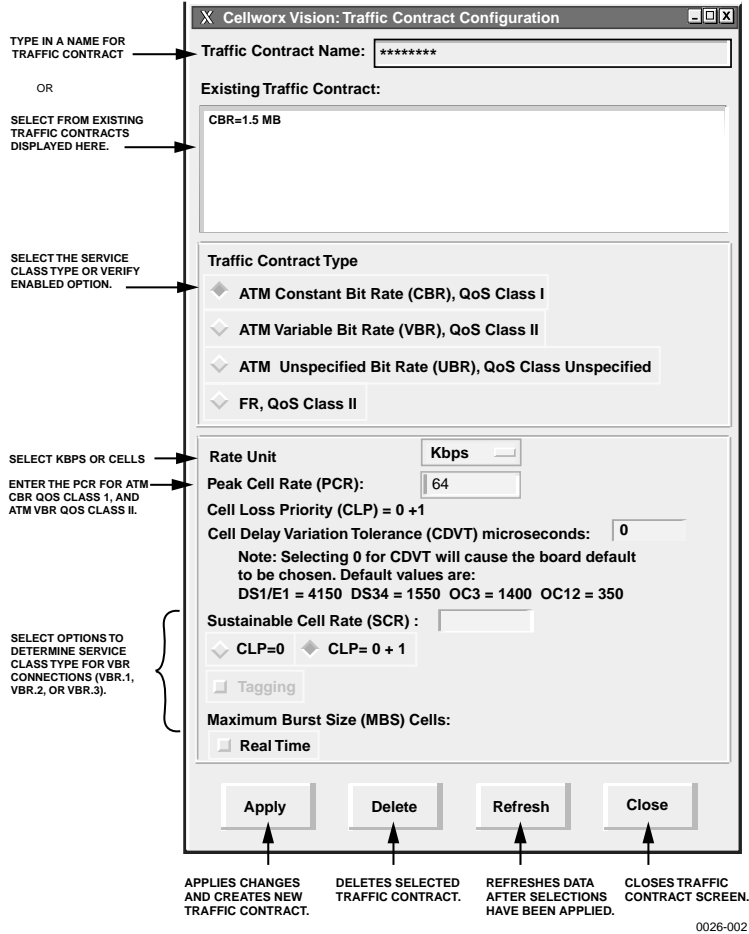

Figure 790-8. Create a Traffic Contract

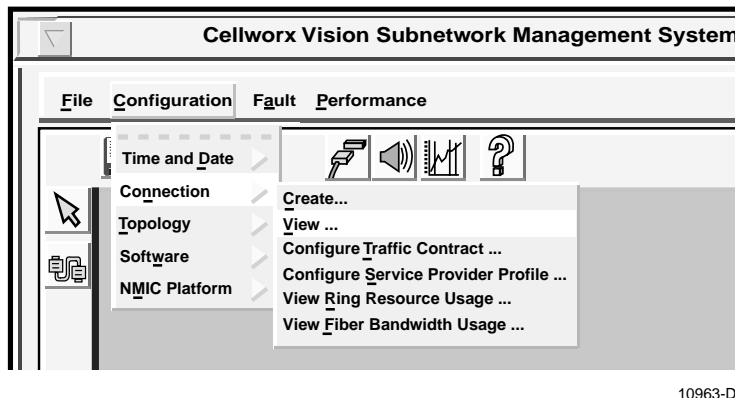

Figure 790-9. GUI Connection Menu Tree

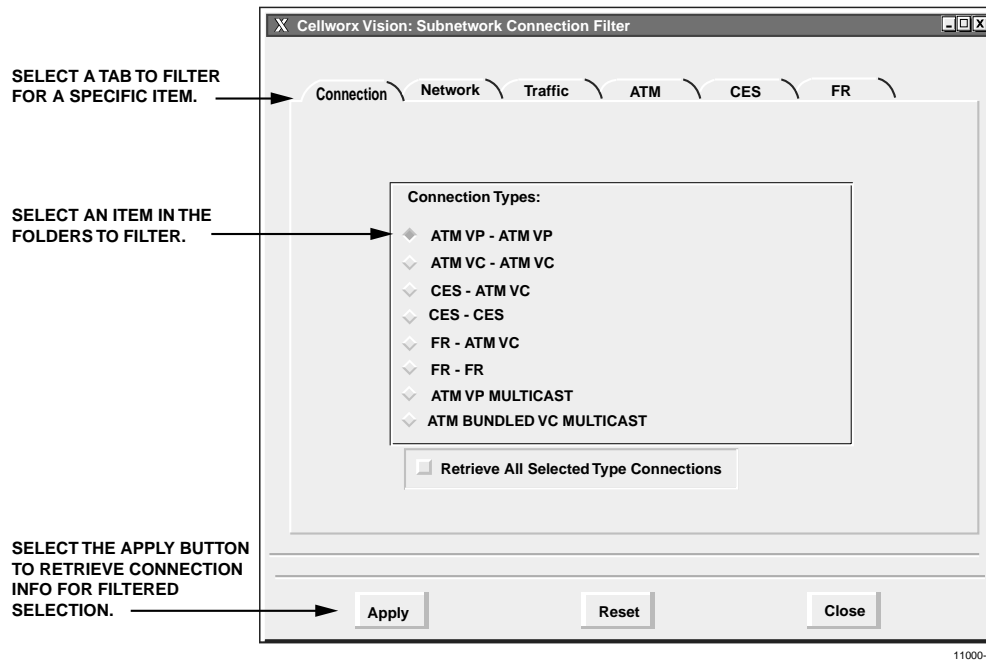

Figure 790-10. Subnetwork Connection Filter Window

Table 790-2. Cellworx Vision Subnetwork Connection Filter Descriptions

FILTER TYPE	OPTIONS	DESCRIPTION
Connection	ATM VP - ATM VP	Selects all ATM VP connections.
	ATM VC - ATM VC	Selects all ATM VC connections.
	CES -VC	Selects all Circuit Emulation Service to ATM Virtual Channel connections.
	CES - CES	Selects all Circuit Emulation Service connections (Phase II).
	FR-ATM VC FR-FR	Frame Relay not supported for Release 3.1 software packages.
	ATM VP Multicast	Selects all virtual path connections that have multiple endpoints associated with them.
	ATM Bundled VC Multicast	Selects all virtual path connections that have multiple endpoints associated with them and bundled virtual circuits contained in the path.
Network	Administrator defined.	Allows user to specify certain NEs when filtering connections.
Traffic	Administrator defined.	Selects the traffic contract to be queried. These are user-defined names. Several connections may utilize the same traffic contract.
ATM	Administrator defined.	Selects the UNI or NNI to be queried. These are user-defined names and apply to specific ports.

DLP-790  
Page 13 of 14

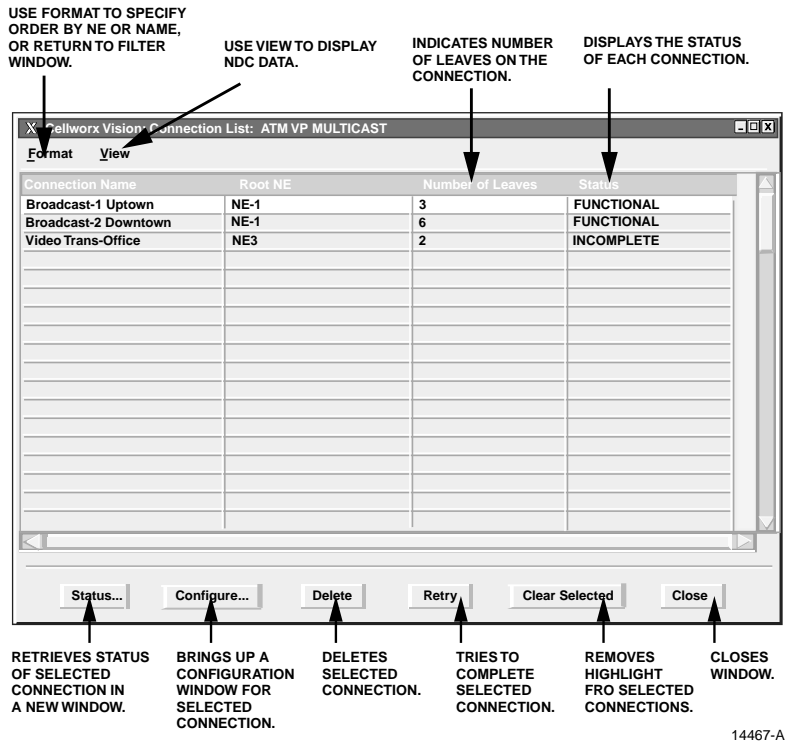

Figure 790-11. ATM Bundled VC Multicast Connection List Screen

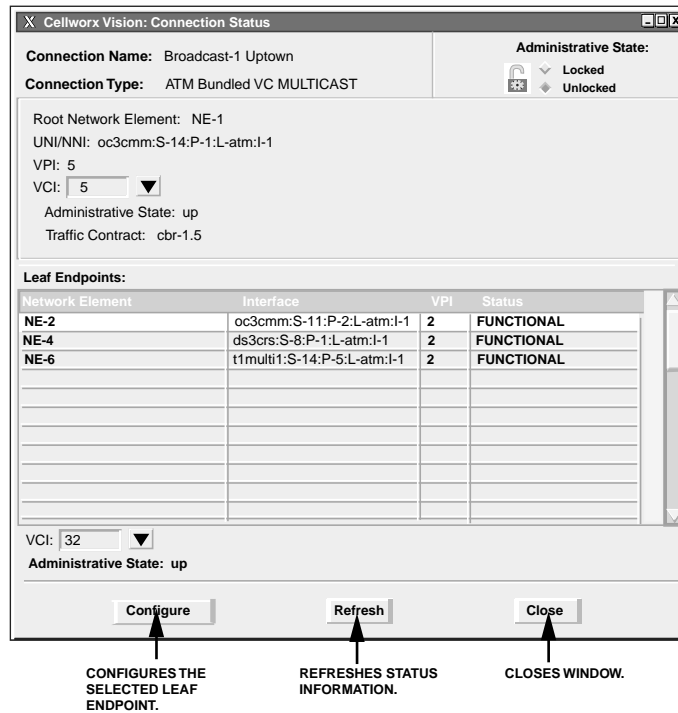

Figure 790-12. ATM Bundled VC Multicast Connection Status Window



**Cellworx Vision: Connection Configuration**

Connection Name: **Broadcast-1 Uptown** Administrative State:  Locked  Unlocked

Connection Type: **ATM Bundled VC MULTICAST**

Root Network Element: **NE-1**  
 UNI/NNI: **oc3cmm:S-14:P-1:L-atm:1-1**  
 VPI: **5**  
 VCI: **32**

Segment Endpoint  Ingress NDC  Egress NDC

**Leaf Endpoints:**

Network Element	Interface	VPI	Status
NE-2	oc3cmm:S-11:P-2:L-atm:1-1	5	FUNCTIONAL
NE-4	DS3crrs:S-8:P-1:L-atm:1-1	5	FUNCTIONAL
NE-6	T1multi1:S-14:P-5:L-atm:1-1	5	FUNCTIONAL

VCI: **32** Administrative State:  Locked  Unlocked

Segment Endpoint  Ingress NDC  Egress NDC

Buttons: **Apply** **Refresh** **Retry Leaf** **Add Leaf** **Delete Leaf** **Close**

**Annotations:**

- DISPLAYS CONNECTION NAME.
- DISPLAYS CONNECTION TYPE SPECIFIED IN SEARCH.
- SELECT USAGE DATA OR NDC COLLECTION FOR ROOT ENDPOINT. HIT APPLY TO UPDATE ANY CHANGES.
- LOCK OUT ANY SELECTED LEAF ENDPOINT.
- HIGHLIGHT A LEAF AND SELECT USAGE DATA OR NDC COLLECTION. HIT APPLY TO UPDATE ANY CHANGES.
- USE TO APPLY NEW NDC AND USAGE DATA SELECTIONS.
- USE TO REFRESH DISPLAYED DATA AFTER RETRY, ADD, OR DELETE LEAF CONNECTIONS.
- USE TO RETRY A FAILED LEAF CONNECTION.
- TAKES USER TO A NEW LEAF CONFIGURATION WINDOW.
- DELETES THE HIGHLIGHTED LEAF ENDPOINT.
- DISPLAYS THE STATUS OF LEAF ENDPOINTS. IF INCOMPLETE OR FAILED, HIGHLIGHT AND SELECT THE RETRY BUTTON AT THE BOTTOM OF THE WINDOW.
- USE SLIDER BAR TO VIEW MORE DATA IF AVAILABLE.
- LOCKS OUT ENTIRE CONNECTION.
- CLOSES WINDOW.

14464-A

Figure 790-13. ATM Bundled VC Multicast Leaf Endpoint Status Window

**DLP-791**

Page 1 of 7

**ADD/DELETE A LEAF ENDPOINT TO/FROM AN EXISTING MULTICAST CONNECTION**

**Summary:** This procedure describes the steps required to successfully add a leaf endpoint to a configured multicast connection. This procedure is generic in nature so it can encompass VP Multicasting AND Bundled VC Multicasting. Adding a leaf endpoint to a bundled VC multicast connection does not affect the VCI configuration and so is identical to adding a VP multicast endpoint. If adding a port level multicast leaf endpoint to a connection that has only one existing leaf endpoint, a traffic hit will occur. Prerequisites of establishing a connection are:

- The connection endpoints hardware (cards/ports) must be provisioned and in service (unlocked) per NTP-006.

► **Note:** User may navigate through the GUI menus using the mouse or by using the Alt key plus the underlined letters in the menus simultaneously, and then the arrow keys to scroll up, down, or across. Refer to the Graphical User Interface Operation in Section 2 of this document.

1. Access the existing connections using one of the following processes:
  - a. Using the left mouse button, select *Configuration, Connection, and View*. Refer to Figure 791-1.
  - b. Using the direct selection keys, enter *Alt+C, Alt+N* then *Alt+V*. Refer to Figure 791-1.
  - c. Using the right mouse button, position the cursor over the NE, click and hold the button, select *View Connections*, and release the button.
  - d. Using the left mouse button, select the connection icon above the workspace.
2. The Connection Filter window appears as shown in Figure 791-2. Select a topic to filter information from using the folder tabs shown. These topics allow the user to retrieve only the information desired by *Connection* type, *Network* available, *Traffic* contract, or *ATM* traffic by port. The user may also specify all of these by using the *All* checkbox. Refer to Table 791-2 for descriptions of each filter type. Select either the *ATM BUNDLED VC MULTICAST* button or the *ATM VP Multicast* button followed by the *Apply button* at the bottom of the screen.
3. The Connection List window appears as shown in the example in Figure 791-3. The list of connections can be displayed alphabetically by the connection name or by the NE name by using the *Format* pull down menu and selecting *Sort by Name*, or *Sort by NE*. The status column indicates the most current information for the connection. The status may be listed as INCOMPLETE, FUNCTIONAL, or as an UNKNOWN STATE. This screen displays up to 100 entries per page by using the up and down slide button on the right side of the window. If more than 100 entries are available for viewing, the user may use the slide bar on the right side of the window to scroll through the entries.
4. If a connection is displayed as INCOMPLETE, select it using the left mouse button to highlight it and then select *Retry* to attempt to establish the connection.

## Deleting Connections

5. The user may delete a connection, or multiple connections, by selecting them using the left mouse button, and then selecting *Delete*. A confirmation message will appear requiring the user to select *OK* or *Cancel*. If a problem exists with the hardware between the NMIC and the endpoint shelf controllers, a denial message may appear detailing why the connection could not be deleted. Refer to DLP-713 and the trouble log for any error reports.
6. To gain status information of a certain connection, the user double clicks on the connection using the left mouse button, or single clicks to highlight the connection followed by selecting *Status* at the bottom left of the window.
7. The Connection Status window appears similar to the one shown in Figure 791-4. The connection name is displayed at the top of the window. The administrative state may show as Locked or Unlocked. Locked indicates the connection is taken down at both ends, no traffic is allowed on the ring. Unlocked indicates the connection is operable in a normal state. The user may change options on the connection by selecting *Configure*. Access to the Configure screen can also be obtained from the previous Connection List screen via the *Configure* selection button found there.

## Deleting Endpoints

8. Select the Configure button at the bottom of either the status window or the Connection List window. The Connection Configuration screen appears. Refer to Figure 791-5. The connection name is displayed at the top of the window. The user may delete n endpoint or multiple endpoints by selecting them using the left mouse button, and then selecting *Delete*. A confirmation message will appear requiring the user to select *OK* or *Cancel*. If deleting the last endpoint on a connection, the system will warn that the root end of the connection will also be deleted.

## Changing Endpoint Configuration

9. Either or both ends of the connection can be configured as OAM cell segment endpoints by selecting the Segment Endpoint box displayed at each section of the screen. This functionality can be used for maintenance or troubleshooting purposes. Select *Apply* to send configuration changes to the database or close to abort any changes.
10. The “Configuration Change Completed” window appears. Select *OK*.

## Adding Leaves to a Multicast Connection

11. Leaves may be added to the connection using the *Add Leaf* button at the bottom of the Connection Configuration window. The Leaf Endpoint Configuration screen appears similar to the one shown in Figure 791-6.

**DLP-791**

Page 3 of 7

12. Set the leaf endpoint parameters as needed. The VCI numbers are not configurable as all leaf endpoints share the same VCI ids. Refer to Table 791-2 for configurable endpoint options. Select the **Apply** button once all parameters are entered.
13. The system responds “Successfully Added Leaf to Connection”. Click on **OK** to finish.
14. Click on **Close** to close the Add Leaf window and return to the Connection Configuration window.
15. Repeat steps 11 though 14 for any other leaves that need to be added.

**Stop! You have completed this procedure.**

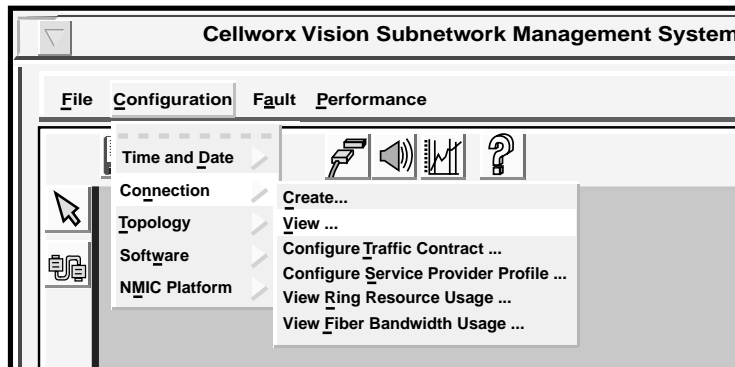

10963-D

Figure 791-1. GUI Connection Menu Tree

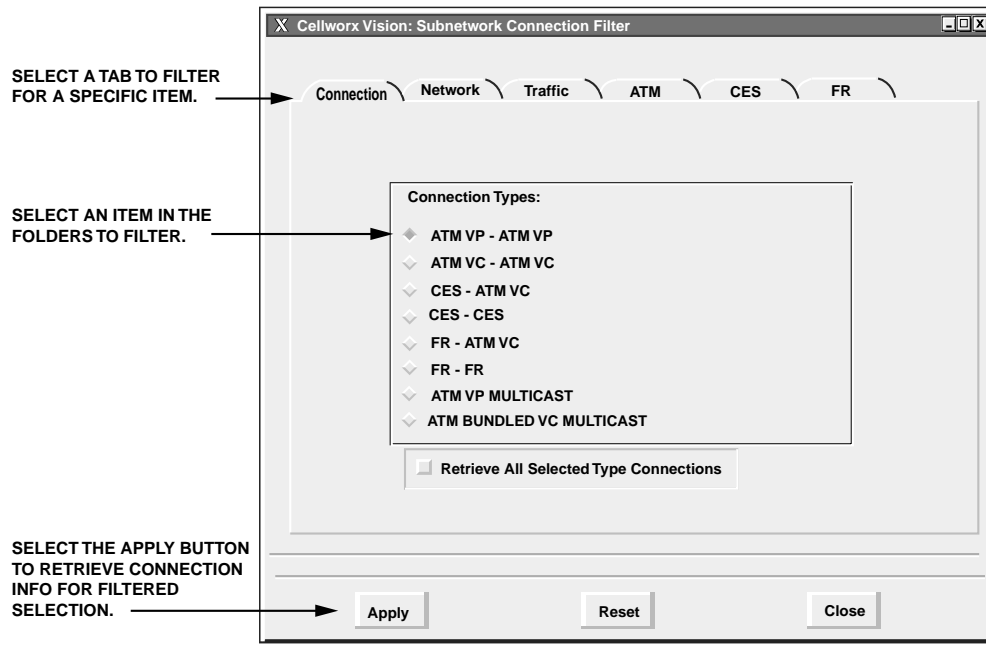

Figure 791-2. Connection Filter Window

Table 791-1. Cellworx Vision Connection Filter Descriptions

FILTER TYPE	OPTIONS	DESCRIPTION
Connection	ATM VP - ATM VP	Selects all ATM VP connections.
	ATM VC - ATM VC	Selects all ATM VC connections.
	CES -VC	Selects all Circuit Emulation Service to ATM Virtual Channel connections.
	CES - CES	Selects all Circuit Emulation Service connections (Phase II).
	FR-ATM VC FR-FR	Frame Relay not supported for Release 3.1 software packages.
	ATM VP Multicast	Selects all virtual path connections that have multiple endpoints associated with them.
	ATM Bundled VC Multicast	Selects all virtual path connections that have multiple endpoints associated with them and bundled virtual circuits contained in the path.
Network	Administrator defined.	Allows user to specify certain NEs when filtering connections.
Traffic	Administrator defined.	Selects the traffic contract to be queried. These are user-defined names. Several connections may utilize the same traffic contract.
ATM	Administrator defined.	Selects the UNI or NNI to be queried. These are user-defined names and apply to specific ports.

DLP-791  
Page 5 of 7

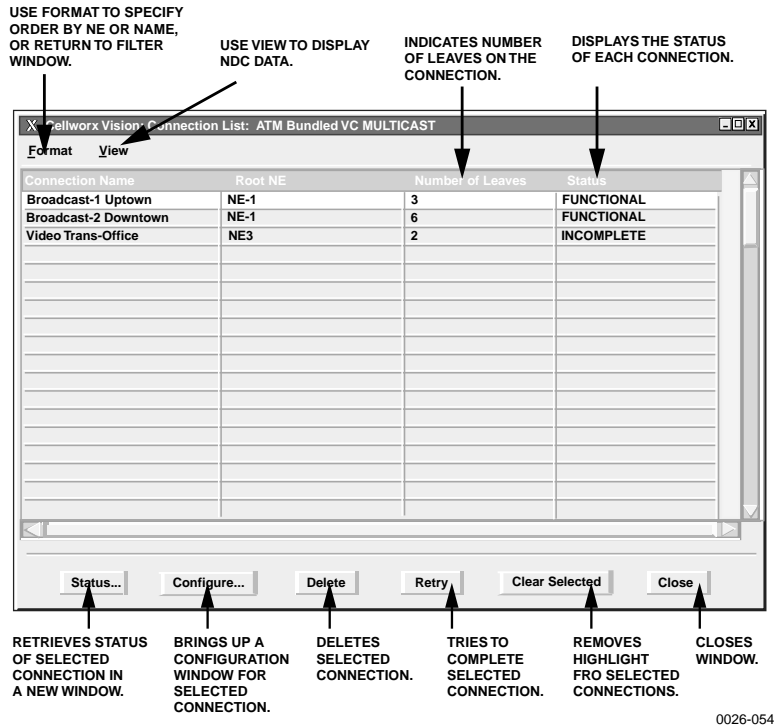

Figure 791-3. ATM Bundled VC Multicast Connection List Screen

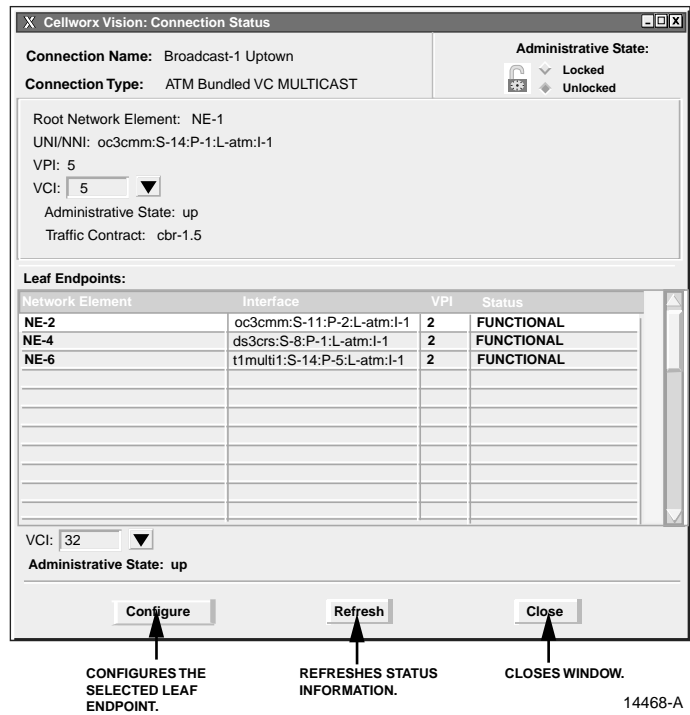
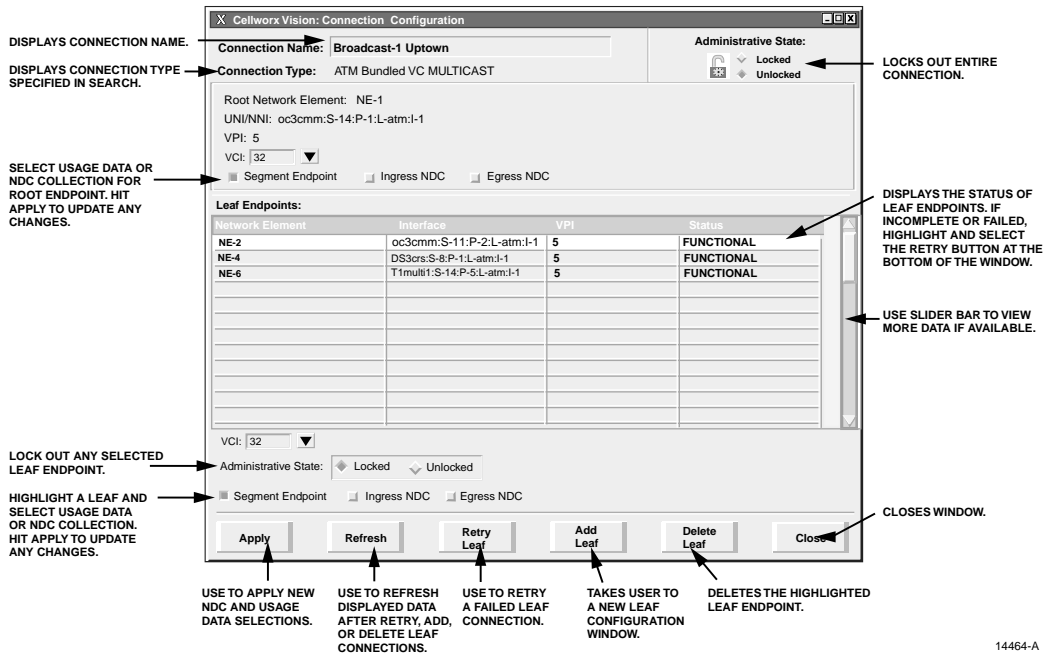
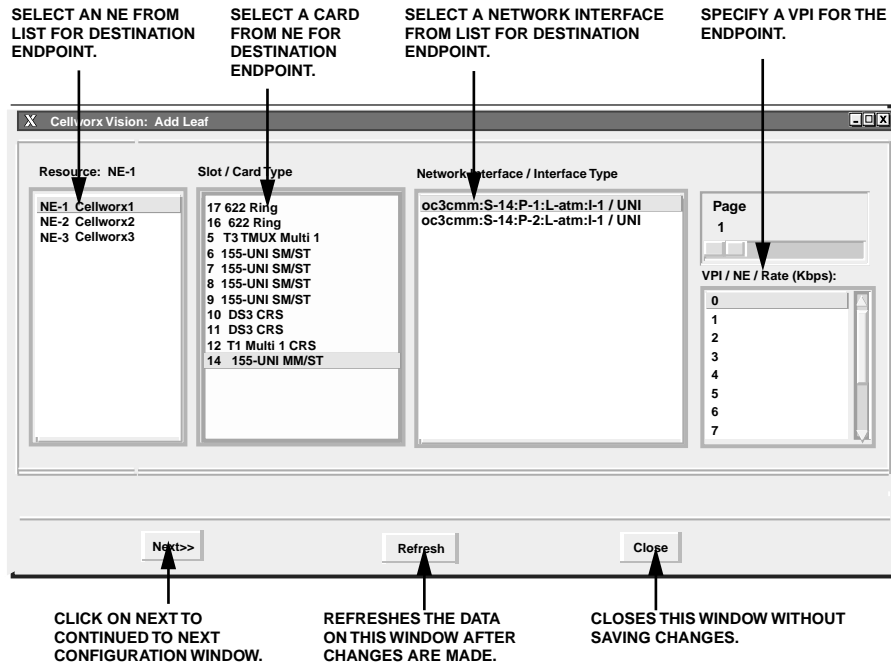

Figure 791-4. ATM Bundled VC Multicast Connection Status Window



14464-A

Figure 791-5. ATM Bundled VC Multicast Configuration Window



14455-A

Figure 791-6. Add Leaf Window - NE, Slot, VPI Selection

DLP-791  
Page 7 of 7

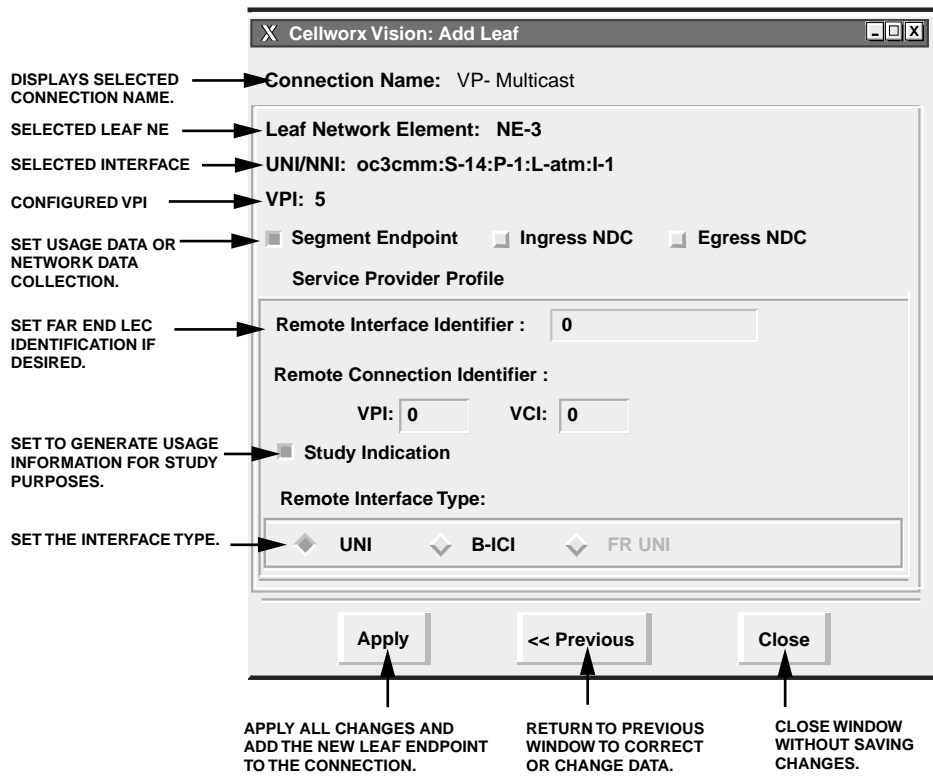

14454-A

Figure 791-7. Add Leaf Window - Configure Endpoint



## SET T3 CES CARD CONFIGURATION

**Summary:** This procedure details the steps required to set the T3 CES card configurations utilizing the Cellworx STN Phase 3.1 shelf level Graphical User Interface (GUI). User must have the GUI launched and accessed the shelf level GUI display per NTP-006 prior to performing this procedure.

1. Double click on the T3 CES card displayed in the shelf level GUI “Chassis View” at the top of the window.
2. The T3 CES card display appears as shown in Figure 792-1. Click on the port to be configured (Port 1, 2, or 3) located on the simulated card on the left side of the window.
3. Click and drag the small block upward to expand the Configuration section of the window so all options are visible. The Administrative State of the card and port should be “Unlocked” if in service. If “Locked”, select the “*Unlocked*” option using the left mouse button to enable the card and/or port for service.
4. Set the Port Level configuration options per requirements. Refer to Table 792-1 for a list of options the user may select for this card type.
5. Hit the *Apply* button at the bottom of the window to back up the new configuration data to the shelf controller.
  - ▶ **Note:** Selecting *Chassis View* will return the user to the previous window without closing the T3 CES window. Selecting *Refresh* will update the current window display and all the selections last recorded by the Shelf Controller card. Selecting *Close* will close this window.
6. Double click on one of the ports available (1, 2, or 3). The CES interface screen appears. Refer to the example shown in Figure 792-2.
7. Set the CES configuration options as needed using Table 792-2 as a reference.
8. Repeat steps 1 through 7 for each T3 CES card/port installed in the shelf.

**Stop! You have completed this procedure.**

DLP-792  
Page 2 of 4

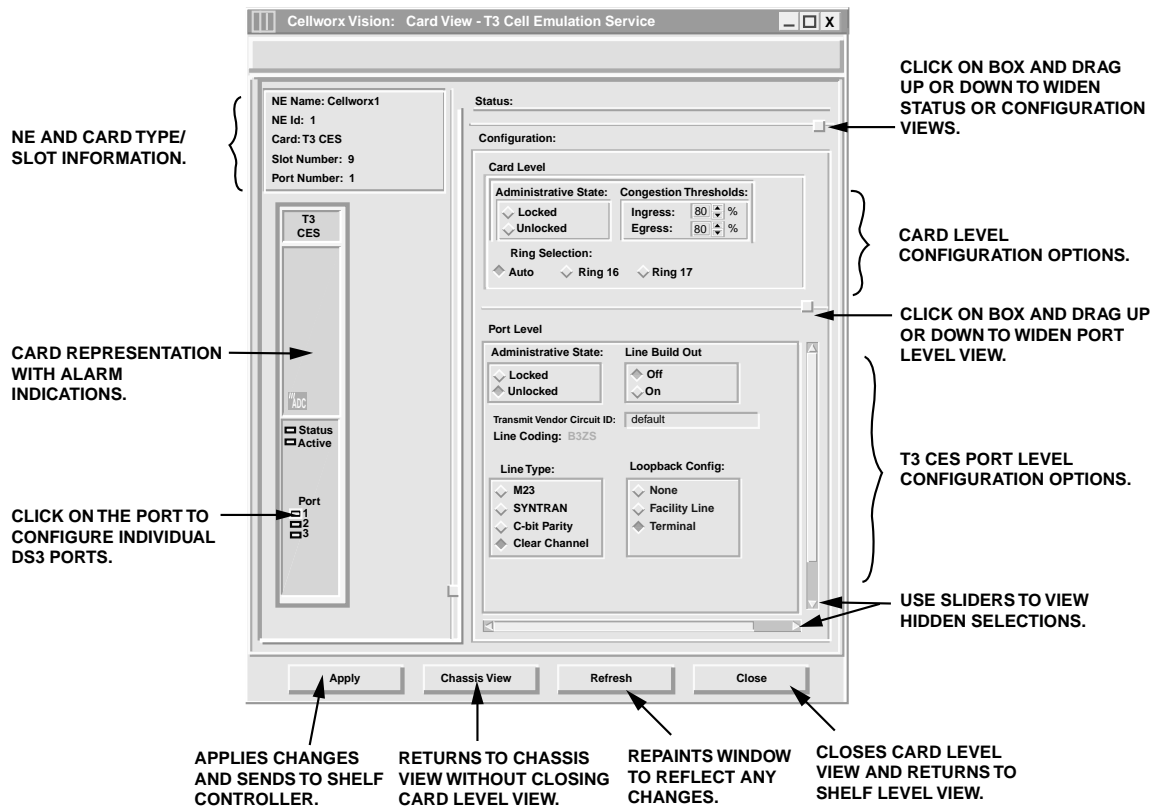

0026-004

Figure 792-1. T3 CES Configuration Screen

Table 792-1. T3 CES Configuration Options

SELECTION	DEFAULT	OPTIONS	DEFINITIONS
Slot Number	2	2 to 15 for Ring NE 2 to 15 for STN-EPS	Physical slot locations of the T3 cards in the shelf.
Admin State (Card or Port)	UNLOCKED	LOCKED/ UNLOCKED	Locked = Out of service. Unlocked = In service.
Congestion Threshold	80	0 to 100 %	Threshold for CLP=1 cells to be discarded on the ingress/egress path.
Ring Selection	Auto	Auto Ring 16 Ring 17	Card will automatically select traffic from the ring direction with the best signal. Card will receive traffic from Ring 16 direction. Card will receive traffic from Ring 17 direction.
Line Build Out	Off	Off On	Turns on the LBO to compensate for cabling distance between EIM and customer equipment.

(continued)

Table 792-1. T3 CES Configuration Options, continued

SELECTION	DEFAULT	OPTIONS	DEFINITIONS
Transmit Vendor Circuit ID	default	User Defined	Can be used to assign a name to the port to identify certain customer circuits.
Line Coding	B3ZS	Not User Configurable	Display only of the line coding.
Line Type	Clear Channel	Not User Configurable	Clear Channel only. No line type interfacing is performed. What transmission type comes in is transported across the network unchanged.
Loopback Config.	None	None Facility Line Terminal	No loopback activated on this card. Loops the incoming signal back to the CPE and generates AIS to the cellbus. Sends cells back to the cellbus and back out to the ring. No changes are made to the path layer.

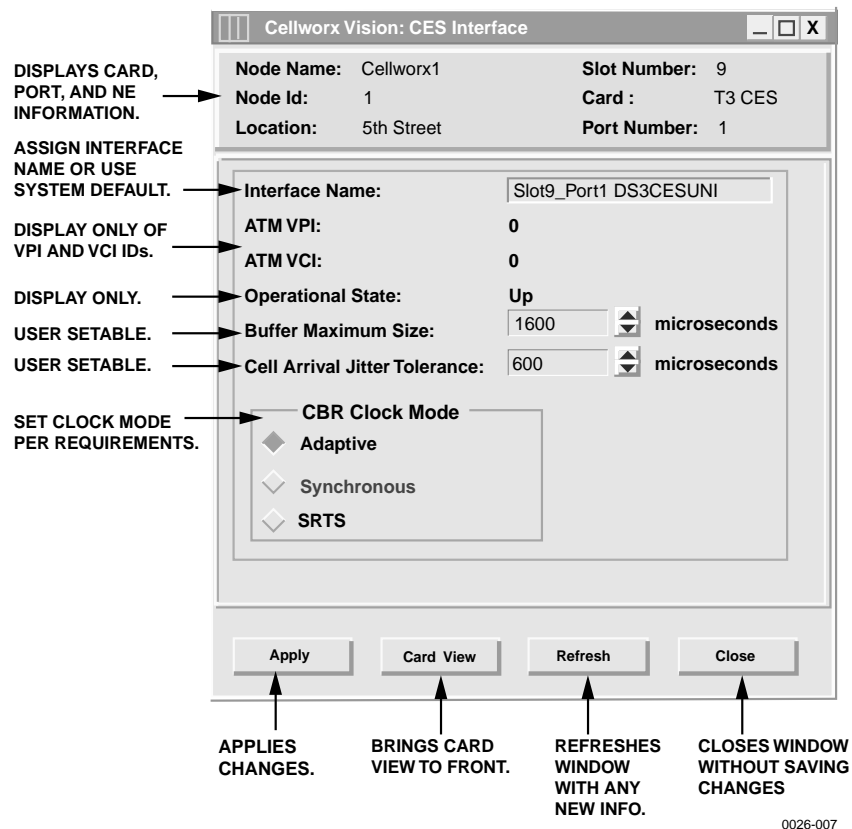

Figure 792-2. T3 CES Interface Configuration Screen

## DLP-792

Page 4 of 4

Table 792-2. T3 CES Interface Configuration Options

SELECTION	DEFAULT	OPTIONS	DEFINITIONS
Interface Name		User Defined	Can be used to assign a name to the port or use the system default.
ATM VPI	<user defined>	0-8	This is a read only to show the available bits configured for this port during connection creation.
ATM VCI	<user defined>	0-10	This is a read only to show the available bits configured for this port during connection creation.
Operational State	Up	Up Down Unknown	Display only. State of the interface port is Up and available for service, Down due to a problem, or Unknown due to communication error.
Buffer Maximum Size	1600	1500 to 2000	Maximum size measured in microseconds and selectable in 10 microsecond increments.
Cell Arrival Jitter Tolerance	800	750 to 1000	Maximum size measured in microseconds and selectable in 10 microsecond increments.
CBR Clock Mode	Adaptive	Adaptive Synchronous SRTS	Sets the Constant Bit Rate clock to adapt to the incoming bit stream, look for a constant synchronous bit stream, or Synchronous Residual Time Stamp used for recovering clock signals in a packet system (ATM).

## RETRIEVE T3 CES CARD STATUS

**Summary:** This procedure defines the information retrieved from the shelf level GUI display for the T3 CES card status. User must have the GUI launched and accessed the shelf level GUI display per NTP-007 prior to performing this procedure.

1. Double click on the T3 CES card located in the shelf level GUI “Chassis View” at the top of the window.
2. Click the small block between the Status and Configuration sections and drag it downward to view all the status information. Refer to Table 793-1 for definitions of status information provided.
3. Select each port on the card to view the statuses.
4. Select the *Close* button at the bottom of the window to return to the chassis level display.

**Stop! You have completed this procedure.**

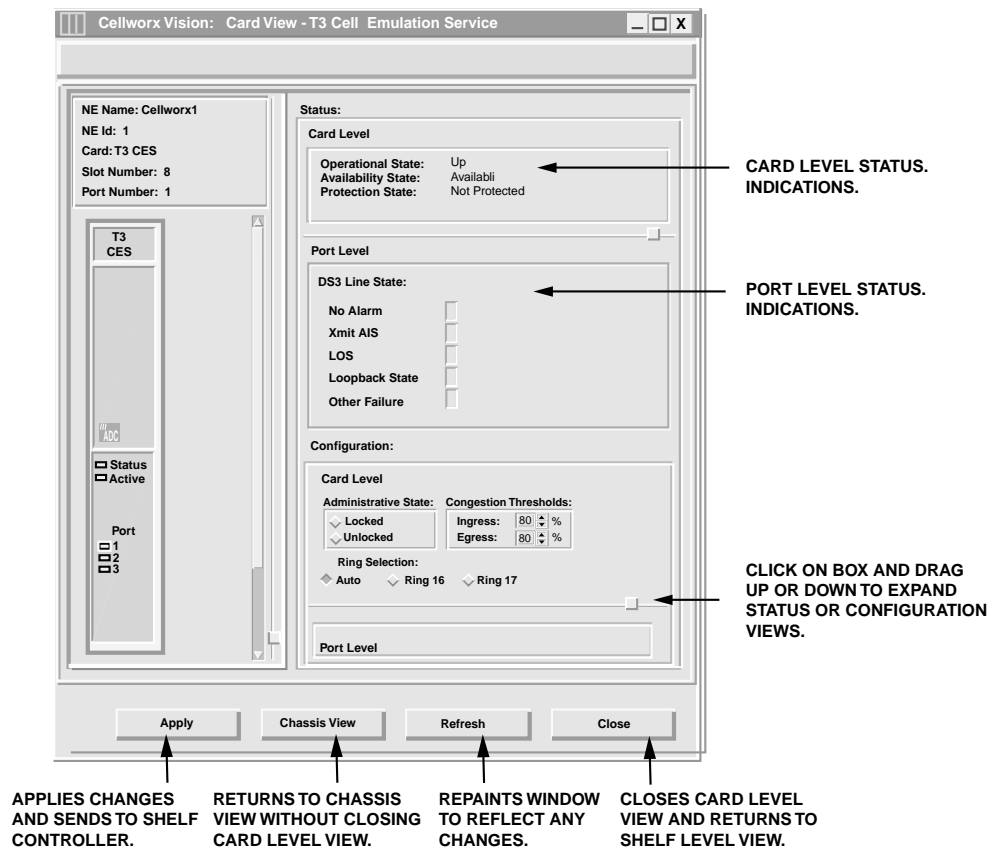

Figure 793-1. T3 CES Card Status Window

Table 793-1. T3 CES Card Status Definitions

ITEM	STATUS	DEFINITION	ACTION
Operational State	Up	Card is functioning properly.	No action required.
	Down	Card is not functioning properly, is in reset mode, or failed. Check Admin state.	Verify card is installed, check for failure indications, or provision card for service per DLP- 792.
	Unknown	The shelf controller does not currently know the operational status.	Wait a few seconds for operations to complete and update the screen.
Availability State	Available	Card is ready for processing commands.	No action required.
	In Test	Card is currently processing test signals.	Wait a few seconds for screen to update.
	Failed	Card has failed operation and system has placed it out of service.	Card may be performing a reset, or the bus may be busy.
	Power Off	No power to the card.	Check power source, replace card if source is good.
	Not Installed	Card is not currently installed in selected slot of the shelf.	If required, install card in selected slot per DLP-777 and provision per DLP- 792.
	Off Line	Card is installed and provisioned but currently off line.	If required, set module on line per DLP- 792.
	Dependency	Card is supplying timing reference, traffic, or other data to the system.	Perform a soft switch over (manual) per DLP-771 to release card dependency if removing.
Unknown	The system processor does not currently know the availability status.	Wait for processor to update current status, may need to perform a manual reset of SC per DLP-773.	
Protection State	Not Protected	Not Protected	If equipped, set up a protection group and provision card for protection per DLP-765.
	Enabled	Protection is available for selected card but is not active.	No action necessary.
	Manual switch	User has manually switched the card to protection.	If required, switch the card back per DLP-771.
	Forced Switch	User has forced card to protection.	If required, release forced switch per DLP-771.
	Lockout	Card cannot switch to protection. It has been locked out by command or switch count.	If required, release manual lock-out per DLP-771.
	Unknown	Protection status information is not available to the shelf controller.	Wait a few minutes and update screen. May need to reset SC, refer to DLP-773.

(continued)

Table 793-1. Display T3 CES Card Status Definitions, continued

ITEM	STATUS	DEFINITION	ACTION
DS3 Line Status	No Alarm	T3 line is operating within normal parameters.	No action required.
	Xmit AIS	Card is transmitting an AIS signal.	Check local T3 signal input.
	LOS	No input signal being received.	Check metallic input and DSX.
	Loopback State	Card has been manually set to loop signal back to customer equipment.	Check customer end for troubleshooting activity. If required, release loopback per DLP-772.
	Other Failure	Card is experiencing a failure other than these listed.	

**DLP-794**

Page 1 of 3

**SET / RETRIEVE T3 CES PORT PERFORMANCE MONITORING STATISTICS**

**Summary:** This procedure describes the steps required to successfully retrieve the performance monitoring statistics for specified T3 CES interface ports within a Cellworx STN network. Information retrieved is on a per node and per port basis. This procedure assumes the user has already accessed the GUI and initiated the Performance Monitoring-Selection window per NTP-008.

1. Select an NE from the list of NEs in the “Resource” section of the window. Refer to Figure 794-1. This will bring up any available card slots in the NE in the next window.
2. Select a slot/card type in the “Slot/Card Type” section of the window and all available ports will appear in the third window. Multiple slots may be selected.
3. Select the port(s) desired to display the performance monitoring layers in the “Port” section of the window. Multiple ports may be selected also.
4. Select the layer or layers to be retrieved in the “Layer” section of the window. If a T3 CES card was selected only AAL1 will be available in the PM layer window. If not, return to step 2 of this procedure and select the proper interface card.
5. Select the time period for the report from the Interval selection window on the right. If multiple interfaces were selected, only a single time interval may be selected. If a single interface was selected, the user may specify several historical time periods to retrieve for the report. The “current” selection will retrieve any errors that are actively logged for the interface(s) specified. In no instance may the current interval and a history interval be selected at the same time.
6. Select the Apply button once all selections have been specified for the performance report. The Performance Monitoring Data window appears. Refer to Figure 794-2 for an example.
7. Error types reported are listed in Table 794-1. The slider bars are used to view the errors that are beyond the viewing area, either up or down for additional slots and ports, or to the right and left for additional error types. The user may update the counts using the Refresh button at the bottom of the screen. If retrieving history counts, the Refresh button is disabled. Refer to TAP-100 at the end of this section for troubleshooting guidelines.

**1 THRESHOLD CONFIGURATION**

8. Users may specify error counts required to trip a system alarm by clicking on the **Configure Thresholds** button at the bottom of the PM Data window. This will bring up a Performance Monitoring Configuration window similar to Figure 794-3.





**DLP-794**  
Page 3 of 3

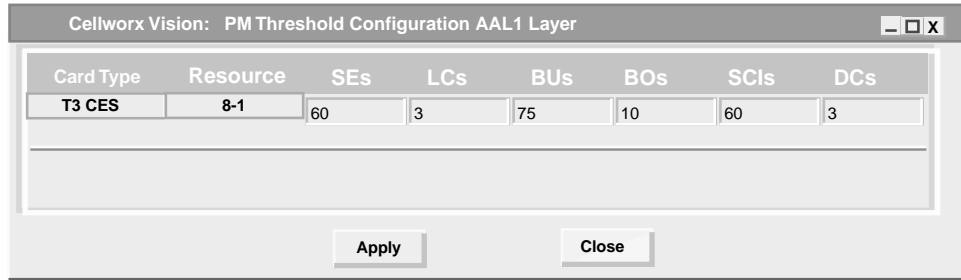

0026-005

**Figure 794-3. Performance Monitoring T3 CES Port Configuration Window**

**Table 794-1. T3 CES Performance Monitoring Values**

MONTYPE	MAX 15-MINUTE THRESHOLD	COMMENTS
SEs	900	Sets the number of AAL1 Sequence Errors the port can incur before the system declares a TCA.
LCs	900	Sets the number of Lost Cells the port can incur before the system declares a TCA.
BUs	900	Sets the number of Buffer Underflows the port can incur before the system declares a TCA.
BOs	900	Sets the number of Buffer Overflows the port can incur before the system declares a TCA.
SCIs	16383	Sets the number of Stuffing Cells Inserted the port can incur before the system declares a TCA.
DCs	900	Sets the number of Discarded Cells the port can incur before the system declares a TCA.

### 3.0 TO 3.1 SOFTWARE RELEASE UPGRADE PROCEDURE

**Summary:** This procedure details the steps required to upgrade the Release 3.0 system software to Release 3.1. The user should have access to an X-terminal or similar workstation device that will allow telnet sessions to the NMIC. The following items are prerequisites to this procedure:

- This procedure must be initiated with the slot 2 NMIC in the “Active” state.
- A Shelf Controller Card (SCC) must be present in slot 1 of every shelf. The SCC does not have to be active but if only one SCC is present in any shelf, it must be in slot 1.
- These UNIX based commands are case sensitive. Pay particular attention to the upper and lower cases shown in the examples when entering commands. All commands are written for a UNIX system. If the user is using a PC for the file transfers, appropriate changes should be made.
- If this Cellworx system has two NMICs, both NMICs should be in the system with EIMs in place and Ethernet connectivity provided to the workstation used for the upgrade.
- It is recommended that the user be familiar with all steps of the upgrade process before beginning.

## 2 DELETE INCOMPLETE CONNECTIONS

The software upgrade procedure cannot be performed if the system has any incomplete connections. Before beginning, open the "Connection List" screen in the CellworxVision GUI and verify that for each connection type there are no incomplete connections. Verify this for VP-VP, VC-VC, CES-VC, CES-CES, VP Multicast, and VC Bundled Multicast connection types. If you do find any incomplete connections, then you must either delete them or complete them.

- ◆ **Note:** Failure to delete incomplete connections prior to attempting the software upgrade procedure can result in irreversible database corruption.

## 3 PLACE SYSTEM INTO STEADY STATE

Verify the system is in steady state prior to proceeding with the software upgrade procedure, i.e., verify that for each protection group the working card is in the active state.

**DLP-795**

Page 2 of 11

**4 SAVE DATABASES**

**Summary:** The user should save all databases (NMIC and NE) from the slot 2 NMIC prior to initiating the software upgrade procedure. Note that this is a precautionary measure only since the databases are also backed up during the procedure itself. Should the NMIC disk become corrupted for some reason, however, it's best to have all databases saved to an external storage medium. The following steps explain how to do this:

1. Open a new shell window or physically connect a laptop or workstation to the NMIC and log into the slot\_2 NMIC as a root user. This shell will be referred to as the "slot\_2 NMIC shell".

```
telnet [IP address of slot_2 NMIC]
```

2. At the slot\_2 NMIC shell, change to the directory in which the databases are located by entering the following command:

```
cd /cellworx/config
```

3. Make a directory on the slot\_2 NMIC used to store the Release 3.0 databases during the upgrade by entering the following command:

```
mkdir release3.0_dbs
```

4. Copy the databases to the new directory by entering the following command:

```
cp NE.? NE.?? NMIC release3.0_dbs
```

- **Note:** The question marks are single character wildcards. **(Do not delete the NE.default file.)**

**5 COPY DATABASES TO AN EXTERNAL DEVICE**

- **Note:** This next section is optional. Having the databases stored on an external device is an extra precaution.

5. Invoke a new shell (not a NMIC shell) on the laptop or workstation. This shell will be referred to as the "Workstation shell". From the Workstation shell, change to the root directory by entering the following command:

```
cd / or cd \ on a PC
```

6. Make a directory called "cellworx" on the external workstation by entering the following command:

```
mkdir cellworx
```

7. Within the cellworx directory on the external workstation, make another directory called release3.0\_dbs by entering the following command:

```
mkdir /cellworx/release3.0_dbs
```

8. Change to the new directory by entering the following command:

```
cd /cellworx/release3.0_dbs
```

9. From the Workstation shell, establish an FTP connection to the slot\_2 NMIC by entering the following command:

```
ftp [IP address of slot_2 NMIC]
```

10. Log into the NMIC as “cellworx” and enter the cellworx password. The default password is blank so the user may elect to press *Enter* or *Return* or enter the cellworx password set by the user followed by *Enter* or *Return*.

11. At the FTP prompt, set the binary file transfer mode by entering the following command:

```
bin
```

12. At the FTP prompt, change to the directory created earlier on the slot\_2 NMIC by entering the following command:

```
cd /cellworx/config/release3.0_dbs
```

13. At the FTP prompt, retrieve (get) all the files in the current directory by entering the following command:

```
mget *
```

14. At the FTP prompt, exit the FTP session by entering the following command:

```
bye
```

## 6 FTP SOFTWARE TO EACH NMIC

**Summary:** The software needed for upgrading each NMIC must be transferred from an external source (most likely a Cellworx CD), to each NMIC. Use the slot 2 NMIC shell from the previous steps to upgrade the slot 2 NMIC. Log into the slot 4 NMIC as the root user from a separate shell to upgrade the slot 4 NMIC.

- Note: Keep both NMIC shell windows open. They will be used throughout the upgrade process.

```
telnet [IP address of the slot 4 NMIC]
```

**DLP-795**

Page 4 of 11

15. In the slot\_2 NMIC shell, create a directory on the slot\_2 NMIC to store the Release 3.1 software. To do this, enter the following commands:

```
cd /tmp - changes to a temporary directory  
mkdir p3.1 - makes a directory called p3.1 under the /tmp directory  
chmod 777 p3.1 - adds write permissions to the /tmp/p3.1 directory
```

16. Open a new shell window and log into the slot\_4 NMIC as a root user. This shell will be referred to as the “slot\_4 NMIC shell”.

```
telnet [IP address of slot_4 NMIC]
```

- **Note:** Keep both NMIC shell windows open because they will be used throughout this upgrade process.

17. Create a directory on the slot\_4 NMIC to store the Release 3.1 software. In the slot\_4 NMIC shell type the following commands:

```
cd /tmp - changes to a temporary directory  
mkdir p3.1 - makes a directory called p3.1 under the tmp directory  
chmod 777 p3.1 - adds write permissions to the /tmp/p3.1 directory
```

18. From the Workstation shell, ftp the software from the Cellworx CD to the directory previously created for the software on the slot\_2 NMIC.

```
ftp [IP address of the slot_2 NMIC]  
bin - sets the binary file transfer mode (done at the ftp prompt)  
hash - optional; provides visual feedback that files are transferring.  
prompt - optional; avoids having user input “y” to transfer each file.
```

19. Change the directory to the CD ROM drive or where the release 3.1 software is located. Replace the “r” in the following command with the proper CD drive designator.

```
lcd r:/upgrade (This command is for PC systems only. For UNIX system  
commands, see the system administrator for mounting a CD ROM on UNIX.)  
cd /tmp/p3.1 - changes the directory on the slot_2 NMIC  
mput * - transfers files from the workstation CD drive to the slot_2 NMIC  
bye - exits the ftp session
```

20. From the workstation shell, ftp the software from the Cellworx CD to the directory previously created for the software on the slot\_4 NMIC.

```
ftp [IP address of the slot_4 NMIC]
bin - sets the binary file transfer mode
hash - optional; provides visual feedback that files are transferring.
prompt - optional; avoids having user input "y" to transfer each file.
```

21. Change the directory to the CD ROM drive or where the release 3.1 software is located. Replace the "r" in the following command with the proper CD drive designator.

```
lcd r:\upgrade (This command is for PC systems only. For UNIX system
                commands, see the system administrator for mounting a CD ROM on UNIX.)
cd /tmp/p3.1 - changes the directory on the NMIC
mput * - transfers files from the workstation CD drive to the slot_4 NMIC
bye - exits the ftp session
```

## 7 INSTALL NEW SOFTWARE ONTO NMIC

- **Note:** The following upgrade steps will not take affect until the upgrade script is run on each NMIC. These steps only copy the images into place.

22. From the slot\_2 NMIC shell, upgrade the kernel by entering the following command:

```
/sbin/.cw/cw_upgradkernel /tmp/p3.1/xImage.3.0.0.7
```

23. From the slot\_4 NMIC shell, upgrade the kernel by entering the following command:

```
/sbin/.cw/cw_upgradkernel /tmp/p3.1/xImage.3.0.0.7
```

24. From the slot\_2 NMIC shell, upgrade the new operating system (OS) by entering the following command:

```
/sbin/cwupgrade /tmp/p3.1/ADC-Linux-upgrade-3.1.0.0-1.ppc.rpm
```

- **Note:** Wait for the second prompt "Done" to appear before continuing.

25. From the slot\_4 NMIC shell, upgrade the new operating system (OS) on the slot\_4 NMIC by entering the following command:

```
/sbin/cwupgrade /tmp/p3.1/ADC-Linux-upgrade-3.1.0.0-1.ppc.rpm
```

- **Note:** Wait for the second prompt "Done" to appear before continuing.

**DLP-795**

Page 6 of 11

26. From the slot\_2 NMIC shell, install the AIC/RIC and SCC software images by entering the following commands:

```
/sbin/cwupgrade /tmp/p3.1/AicSccSwImages-3.1.0.2-2.ppc.rpm
```

27. From the slot\_4 NMIC shell, install the AIC/RIC and SCC software images on the slot\_4 NMIC by entering the following commands:

```
/sbin/cwupgrade /tmp/p3.1/AicSccSwImages-3.1.0.2-2.ppc.rpm
```

28. From the slot\_2 NMIC shell, install the AIC/RIC and SCC bootrom flash images by entering the following commands:

```
/sbin/cwupgrade /tmp/p3.1/AicSccBootroms-3.1.0.5-2.ppc.rpm
```

29. From the slot\_4 NMIC shell, install the AIC/RIC and SCC software images by entering the following commands:

```
/sbin/cwupgrade /tmp/p3.1/AicSccBootroms-3.1.0.5-2.ppc.rpm
```

30. From the slot\_2 NMIC shell, enter the following command to install the Cellworx NMIC software:

```
/sbin/cwupgrade /tmp/p3.1/cellworx-3.1.0.1-1.ppc.rpm
```

31. From the slot\_4 NMIC shell, install the Cellworx NMIC software:

```
/sbin/cwupgrade /tmp/p3.1/cellworx-3.1.0.1-1.ppc.rpm
```

32. From the slot\_2 NMIC shell, install the Feature Package software by entering either one of the following commands depending on the feature package ordered:

```
/sbin/cwupgrade /tmp/p3.1/FeatureControl_aa-3.1.0.0-1.ppc.rpm
```

or

```
/sbin/cwupgrade /tmp/p3.1/FeatureControl_ab-3.1.0.1-1.ppc.rpm
```

33. From the slot\_4 NMIC shell, install the Feature Package software by entering either one of the following commands depending on the feature package ordered:

```
/sbin/cwupgrade /tmp/p3.1/FeatureControl_aa-3.1.0.0-1.ppc.rpm
```

or

```
/sbin/cwupgrade /tmp/p3.1/FeatureControl_ab-3.1.0.1-1.ppc.rpm
```



## 8 UPGRADE THE STANDBY NMIC (SLOT 4)

34. In the slot 4 NMIC shell, change to the directory in which the software upgrade process is located:

```
cd /cellworx/swImage/swLoad_Ver3/nmic.3.1.0.1/bin
```

35. Start the software upgrade process. (The entire procedure for upgrading the slot 4 NMIC (standby NMIC) should take no more than 15 minutes.) This step invokes a graphical procedure that is used to walk the user through all required steps for upgrading the slot 4 NMIC.

► **Note:** The user should keep the NMIC shell open following this procedure, as a manual reboot of the slot 4 NMIC following upgrade will be necessary. At the end of this procedure, the application software on the slot 4 NMIC will be halted, and the LEDs will turn red.

36. The `-h` flag in the following command is used to specify the number of hours in which software fallback is allowed. Valid values are 0-168 (up to and including 7 days). The default value is 24 hours. For example, a value of 48 means the user cannot perform software fallback after 48 hours following software upgrade:

```
./cw_swupgrade -s 3.1.0.1 -h (hours)
```

## 9 UPGRADE THE ACTIVE NMIC (SLOT 2)

37. After standby NMIC upgrade completion (the LEDs on the slot 4 NMIC faceplate should be red), start the software upgrade procedure on the slot 2 NMIC (the active NMIC). This step invokes a graphical procedure that walks the user through the necessary steps for upgrading software for the entire ring. The user should follow the directions and load release 3.1 software onto each AIC, RIC, and SCC in the ring:

```
cd cellworx/swImage/swLoad_Ver3/nmic.3.1.0.1/bin
```

```
./cw_swupgrade -a 3.1.0.1 -h (hours)
```

38. Periodically click the Refresh button on the software configuration screen(s) to see when the software download is completed for each NE. Optionally, the user may close all software configuration screens and use the Refresh button on the main status screen. Clicking this button is equivalent to clicking the Refresh button on each of the NE's software configurations screens.
39. When the release 3.1 software download is complete for each NE, its entry in the main status screen will read, "NE is eligible for switchover." This must be done for all NEs in the ring.

## DLP-795

Page 8 of 11

40. Step 8 of the Task Overview (this is the window that outlines the software upgrade tasks, with check marks placed beside completed tasks and a hand pointing to the task in progress) allows the user to cancel the upgrade procedure. Note that this is not traffic affecting and a NMIC reset is unnecessary.
41. Step 12 of the Task Overview also allows the user to cancel the procedure. Note that this is also not traffic affecting but does require the slot 2 NMIC to be rebooted.
42. Following step 12 of the GUI Task Overview, any problems that cause software upgrade to fail can be traffic affecting. Should any assistance be needed at any point after this step, contact ADC Technical Support at 1-800-366-3891, extension 4878.
43. Following the slot 2 NMIC upgrade, this NMIC is automatically rebooted. After reboot, it will be running release 3.1 software. Note that until each of the SCCs reach their 5-minute switchover time and performs a soft reset, there will be a window of time during which communication is lost between the slot 2 NMIC and the SCCs. This window should be no more than 10 minutes.
44. After the slot 2 NMIC has successfully rebooted, log back into it and start the Cellworx GUI. Replace "[hostname]" in the following commands with the IP address of the laptop or workstation:

```
telnet [IP address of the slot 2 NMIC]
export DISPLAY=[hostname]:0
/cellworx/bin/CellworxVision
```

45. After the Cellworx GUI has been started on the slot 2 NMIC, manually reboot the slot 4 NMIC by entering the following command in the slot 4 NMIC shell window:

```
/sbin/reboot
```

46. After the slot 4 NMIC reboots, a database restoration window will appear on the Cellworx GUI screen from the slot 2 NMIC.

- ◆ **Note:** It is imperative that the user selects the slot 2 NMIC for database restoration because only the database files on this NMIC were converted from release 3.0 format to release 3.1 format.



**Warning:** Following the software upgrade procedure, there are several actions that could invalidate software fallback. The user **SHOULD NOT** perform any of the following tasks unless he is certain that a software fallback from release 3.1 to release 3.0 is not necessary.

- Make any topology modifications (add/remove NE, all shelf types)
- Remove any existing cards
- Delete any existing connections
- Change the time of day clock
- Perform a ring upgrade (OC3c --> OC12c, etc.)
- Remove any file in the /cellworx/config directory with the extension, ".release3.0". These files **must be present** in order to perform a software fallback.

Also be aware of the following restrictions:

- If a release 3.1 card is installed in a shelf (such as OC12c CRS), remove that card before performing software fallback.
- Delete any connections that are created following software upgrade before attempting software fallback.

## DLP-795

Page 10 of 11

### 10 UPGRADE THE BOOTROM FLASH

47. From the main GUI screen (which is running on the slot 2 NMIC), open the Gateway Network Element (GNE) pop-up menu by right-clicking on the GNE icon (the text underneath the GNE icon will be yellow - text for all other NE icons is in white). Select the Reflash Boot Image menu option.
48. In the resulting screen, select the release 3.1 bootrom for each card installed in the shelf (except the NMIC). To do this, right-click on each row in the table and select the appropriate bootrom image. The following images should be selected:

**SCC = 3.1.0.0** (the SCC flash image was previously installed in step 36)

**AIC/RIC = 3.0.1.3**

49. Once release 3.1 bootrom images have been selected for all cards in the GNE shelf, click the Apply button. Wait about 5 minutes and then click the Refresh button to update the download status for the cards. All cards should say, "Loaded". If not, wait a few more minutes and click Refresh again.
50. Once all cards are loaded with the release 3.1 bootrom, each card in the shelf must be hard reset to load the new bootrom.
  - ▶ **Note:** Hard resetting a card is traffic affecting. When you upgrade the flash bootrom on each card, you may want to take this into consideration. To minimize traffic loss, you should consider using 1+1 or 1:N protection and resetting the cards such that a card is always active. This will take longer, but you will avoid traffic loss.
51. Repeat steps 50 through 55 for each NE in the ring.
52. Following hard reset of all cards in all NEs in the ring, software upgrade is complete.

**Stop! You have completed this procedure.**

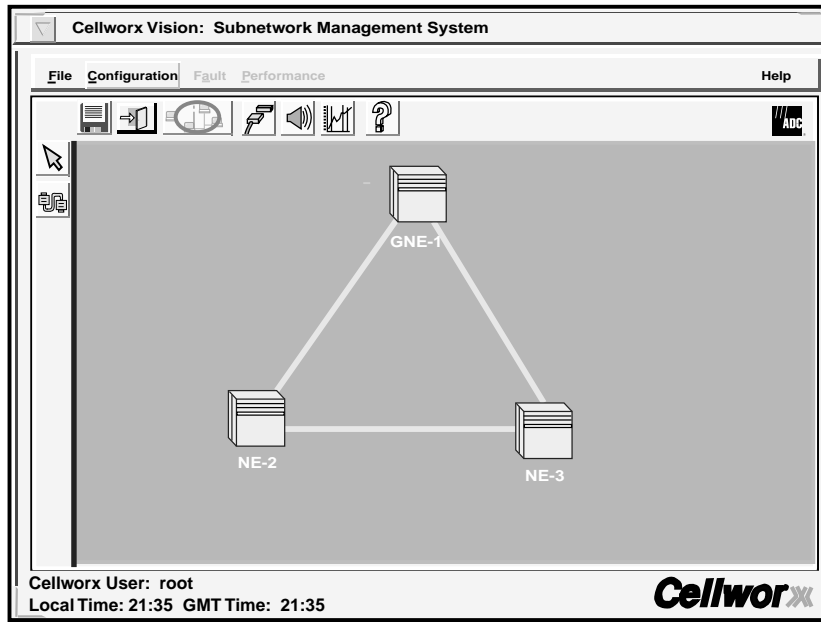

10924-D

Figure 795-1. GUI Main Screen (example)

### RETRIEVE 622 CRS STATUS

**Summary:** This procedure defines the information retrieved from the shelf level GUI card status display for the 622 CRS card. User must have the GUI launched and accessed the shelf level GUI display per NTP-007 prior to performing this procedure.

1. Double click on the 622 CRS card located in the shelf level GUI “Chassis View” at the top of the window.
2. Click the small block between the Status and Configuration sections and drag it downwards to view all the status information. Refer to Table 796-1 for definitions of status information provided.
3. Select the *Close* button to close the screen and return to the shelf view.

**Stop! You have completed this procedure.**

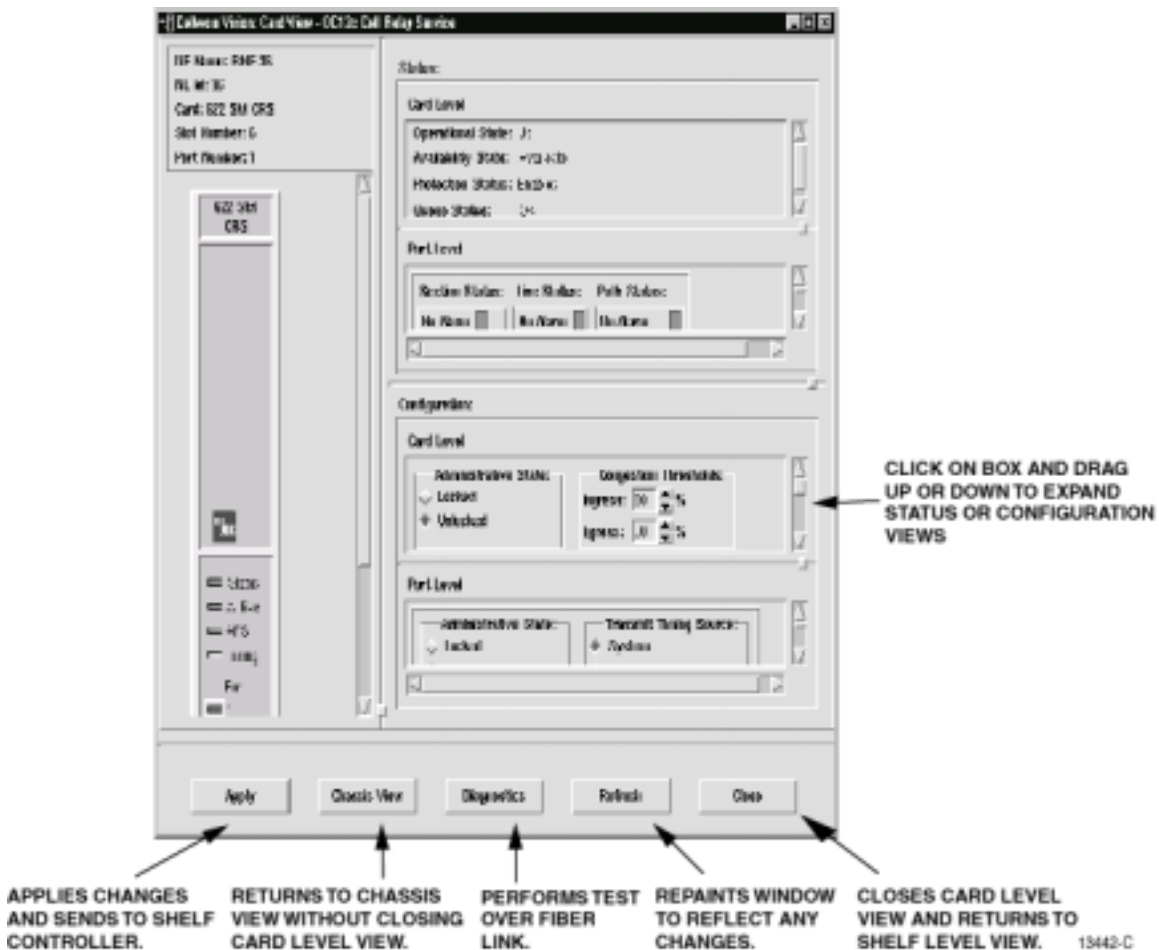

Figure 796-1. 622 CRS Card Status Window

Table 796-1. 622 CRS Card Status Definitions

ITEM	STATUS	DEFINITION	ACTION
Operational State	Up	Card is installed and provisioned for service.	No action required.
	Down	Card is not provisioned for service, is in reset mode, or failed.	Verify card is installed, check for failure indications or provision card for service per DLP-797.
	Unknown	The shelf controller does not currently know the operational status.	Wait a few seconds for operations to complete and update the screen.
Availability State	Available	Card is ready for processing commands.	No action required.
	In Test	Card is currently processing test signals.	Wait a few seconds for screen to update.
	Failed	Card has failed operation and system has placed it out of service.	Card may be performing a reset, or the bus may be busy.
	PowerOff	Card is manually powered off.	Check power source, replace card if source is good per DLP-777.
	Not Installed	Card is not currently installed in selected slot of the shelf.	If required, install card in selected slot per DLP-777 and provision per DLP-797.
	Offline	Card is installed and provisioned but currently off line.	If required, set module on line (unlocked) per DLP-797.
	Dependency	Card is supplying timing reference, traffic, or other data to the system.	Perform a soft switch over (manual) per DLP-771 to release card dependency if removing.
	Unknown	The shelf controller does not currently know the availability status.	Wait for processor to update current status, may need to perform a manual reset of SC per DLP-773.
Section Status	No Alarm	No errors between local and next node.	No action required.
	LOS	Loss Of Signal. Cannot locate section data.	Check connectors, fiber, and then transmitter at remote end.
	LOF	Loss Of Frame. Cannot locate frame bit of section data.	Check signal configuration and power level of received signal.
Line Status	No Alarm	Receiving good input signal.	No action required.
	AIS	Alarm Indication Signal. All 1s or blue signal inserted at originating node.	Check signal status at traversing nodes, and low speed signal input at transmitting node.
	RDI	Remote Defect Indicator.	Problem at transmitting end.
Path Status	No Alarm	Receiving good input signal.	No action required.
	STS LOP	STS signal Loss Of Pointer.	Check sync reference sources and inputs.

(continued)

**DLP-796**  
Page 3 of 3

**Table 796-1. 622 Card Status Definitions, continued**

ITEM	STATUS	DEFINITION	ACTION
Path Status (continued)	STS AIS	STS Alarm Indication Signal. Remote end transmitting AIS due to loss of payload for path.	Check remote transmitting end's input signal.
	STS RDI	STS Remote Defect Indication. Remote end is receiving a defective signal.	Check local end transmitter and connections.
	Unequipped	This time slot is not utilized (unequipped).	Create a connection if needed on this available timeslot per DLP-708.
	SignalLabel Mismatch	Type of signal does not match overhead description.	Check VP connection for provisioning errors per DLP-710.
Sync Status	PRC	SDH Primary Reference Clock	Timing reference reliability levels. If sync status does not meet required level, check source and inputs. Provide the required clock source and change configuration settings for the card per DLP-749.  No action required.
	PRS	Primary Reference Source	
	SEC	SDH Equipment Clock Traceable	
	SSU	SDH Sync Supply Unit Traceable	
	ST1	Stratum 1 level source	
	STU	Synchronized Traceability	
		Unknown	
	ST2	Stratum 2 level source	
	ST3	Stratum 3 level source	
SMC	SONET Minimum level Clock		
DUS	Reference cannot be used for source		
Received Path Trace Msg (SM card only)	User Defined	Path trace is a 64-character string assigned to a path between nodes in either direction identifying the transmitting node.	No action required. If message states no path trace, one may be provisioned, for SM cards only, at either or both of the two adjacent nodes (clockwise and counter-clockwise node). Refer to DLP-797.
	No Path Trace		
Protection State	Not Protected	Not Protected	If equipped, set up a protection group and provision card for protection per DLP-765.
	Enabled	Protection is available for selected card but is not active.	No action necessary.
	Manual switch	User has manually switched the card to protection.	If required, switch the card back per DLP-771.
	Forced Switch	User has forced card to protection. Card cannot switch to protection.	If required, release forced switch per DLP-771.
	Lockout	It has been locked out by command or switch count.	If required, release manual lock-out per DLP-771.
Unknown	Protection status information is not available to the shelf controller.	Wait a few minutes and update screen. May need to reset SC, refer to DLP-773.	



**DLP-797**

Page 1 of 4

**SET 622 SM CRS CARD CONFIGURATION**

**Summary:** This procedure details the steps required to set the 622 SM CRS card configurations utilizing the Cellworx STN Phase 3.1 shelf level Graphical User Interface (GUI). Configuration can be set for the card, port and ATM interface on individual ports. This procedure is divided into two sections with the second section dealing with the ATM interface screens. The user must have the GUI launched and accessed the shelf level GUI display per NTP-006 prior to performing this procedure.

**1. CARD AND PORT CONFIGURATION**

1. Double click on the 622 SM CRS card displayed in the shelf level GUI “Chassis View” at the top of the window.
2. The 622 SM CRS card display appears as shown in Figure 797-1. Click on the port to be configured (Port 1 or 2) located on the simulated card on the left side of the window.
3. Click and drag the small block upward to expand the Configuration section of the window so all options are visible. The Administrative State of the card and port should be “Unlocked” if in service. If “Locked”, select the “**Unlocked**” option using the left mouse button to enable the port for service.
4. At Timing Port, select the port that will be used as a reference if this slot is selected as a timing source from the Timing Resource Screen.
5. If this card and port are being utilized as an expansion shelf interface (either from ring to EPS, or EPS to ring), select the Expansion Shelf Interface button.
6. Set the Port Level configuration options per requirements. Refer to Table 797-1 for a list of options the user may select for this card type.
7. Hit the **Apply** button at the bottom of the window to back up the new configuration data to the shelf controller.

► **Note:** Selecting **Chassis View** will return the user to the previous window without closing the 622 SM CRS window. Selecting **Refresh** will update the current window display and all the selections last recorded by the Shelf Controller card. Selecting **Close** will close this window.

**2. ATM INTERFACE CONFIGURATION**

8. Double click on port 1. The ATM interface screen appears. Refer to the example shown in Figure 797-2.
9. Set the ATM options as needed using Table 797-2 as a reference.

10. Repeat steps 1 through 9 for each 622 SM CRS card installed in the shelf.

**Stop! You have completed this procedure.**

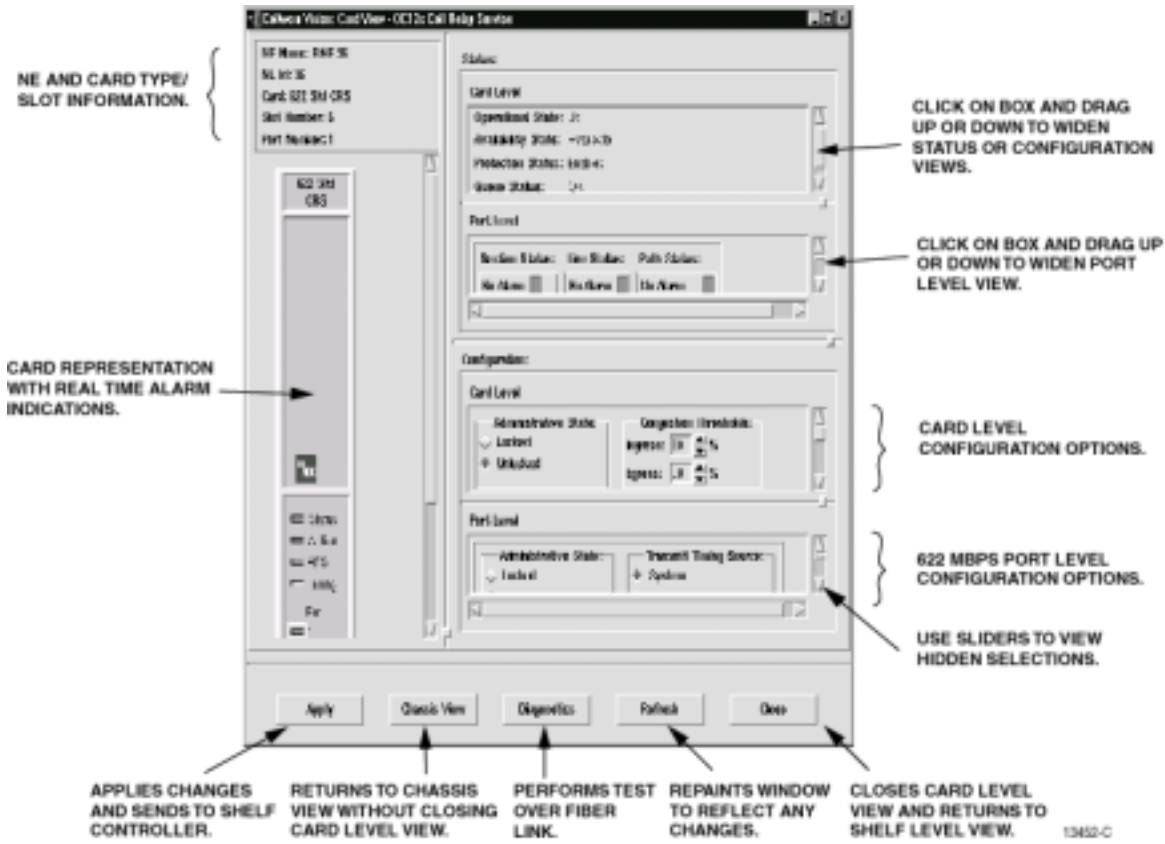

Figure 797-1. 622 SM CRS Card Shelf Level GUI Configuration Screen

Table 797-1. 622 SM CRS Card Configuration Options

SELECTION	DEFAULT	OPTIONS	DEFINITIONS
Admin State	Unlock	Lock / Unlock	Enable or disable card / port for service.
Congestion Threshold	80	0-100	Percentage of ingress buffer capacity that will cause a congestion threshold notification.
Ring Selection	Auto	Auto Ring 16 Ring 17	Card will automatically select traffic from the ring direction with the best signal. Card will receive traffic from Ring 16 direction. Card will receive traffic from Ring 17 direction.
Timing Port Selection	1	1 or 2	Selects the port to use as a reference when this slot is selected as the shelf timing source.
Shelf Expansion Interface	Selected	Selected Not selected	Determines if the 622 SM CRS card is being used as an expansion shelf interface (SEPIC) in an EPS or RNE. Click on the box to select it.

(continued)

**DLP-797**  
Page 3 of 4

**Table 797-1. 622 SM CRS Card Configuration Options, continued**

SELECTION	DEFAULT	OPTIONS	DEFINITIONS
Transmit Timing Source	System	System Received	Uses Primary timing reference. Uses clock derived from incoming receive fiber (also known as Line-Timing).
Do Not Use for Sync	False	Selected (True) Non-selected (False)	Outputs DUS (Do not Use for Sync) in the S1 byte of the SONET overhead.
Enable Signal Degrade	Not Selected	Selected Not Selected	Enables a protection switch of the traffic if the input signal strength drops below tolerable levels set by the user in the BER threshold selection.
Signal Degrade BER Threshold	5	5 through 9	Defines the number of bit errors the port can incur before a signal degrade occurs and generates an alarm message and probably protection switch.
Medium Type	SONET	SONET SDH	Synchronous Optical Network, US standard for transporting data over fiber. Synchronous Digital Hierarchy, European standard for transporting data over fiber.
Loopback Towards	None	None Terminal Facility	No loopback is requested or active. A loopback has been activated sending the signal back to the terminal side. A loopback has been activated sending the signal back to the facility side.
Line Coding	NRZ		Not configurable by user.
Line Type	Card Dependant	SonetOther sonetShortSingleMode sonetLongSingleMode	Not configurable by user, dependant on card type inserted.
Transmit Path Trace	User defined		User can define a unique ID to this port for identification purposes on SM cards only.

**Table 797-2. ATM Interface Configuration Options**

SELECTION	DEFAULT	OPTIONS	DEFINITIONS
Interface Name	<default>	Alphanumeric	User defined, up to 20 alphanumeric characters.
Loopback Location Code	All 1s	Alphanumeric	Used to loopback the incoming signal and transmit it back to the customer equipment. The code is limited to 16 numeric characters.

(continued)

Table 797-2. ATM Interface Configuration Options, continued

SELECTION	DEFAULT	OPTIONS	DEFINITIONS
Recording Interface ID	All 0s	Numeric	Identifies the site card and port location for customer billing capabilities, (allows assignment of a customer ID for each port.) The code is limited to 15 numeric characters.
UNI/ NNI Select	UNI	UNI NNI	Specifies interface type as User to Network Interface or Network to Network Interface.
CAC Formula	PCR	PCR SCR	Specifies Peak Cell Rate or Sustained Cell Rate for Connection Admission Control calculations.
Traffic Policing	Enable	Enable Disable	User sets whether traffic will be policed for Quality Of Service (QOS).
Cell Scrambling	True	True or False	User sets whether traffic will be scrambled.
Subscription Rate	100	PCR: 100 to 1000 SCR: 1 to 100	User sets depending on traffic contract.
Max Active VPI/VCI Bits	0	0 to 12	Sets maximum number of bits allowed to select virtual channel from.
Max number of VPCs	4096	0-4096	Sets maximum number of virtual path circuits that may be assigned on this port.
Max number of VCCs	0	0-8192	Sets maximum number of virtual channel circuits that may be assigned on this port.

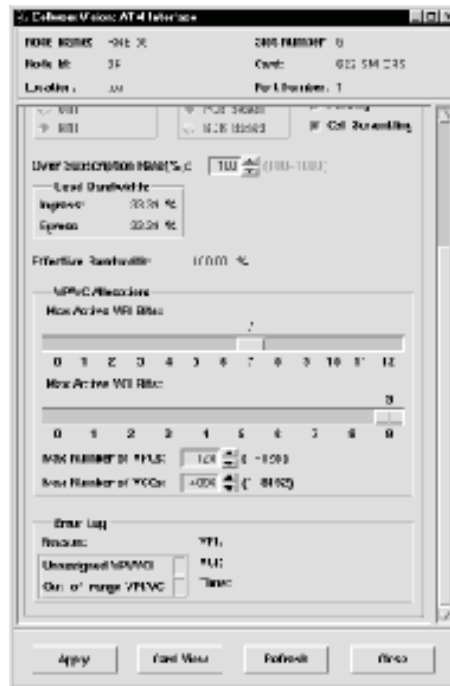

Figure 797-2. 622 SM CRS ATM Port Interface Configuration Screen

**DLP-798**

Page 1 of 3

**SOFTWARE FALLBACK FROM RELEASE 3.1 TO RELEASE 3.0**

**SUMMARY:** The software fallback feature is used to revert to a previous software load after a successful software upgrade. The idea is to restore a system back to the state it was in prior to upgrade. Fallback implies that an unacceptable problem has been encountered after upgrade and the customer wants to revert to the previous software version.

This procedure is specific to release 3.1. It is used after upgrading from release 3.0 to release 3.1 when unanticipated problems necessitate falling back to release 3.0 software. Note that fallback is only allowed for the first 24 hours following software upgrade **by default**. This timeframe is specified during the upgrade process. The fallback procedure consists of several steps outlined as follows:

- This procedure must be initiated with the slot\_2 NMIC in the active state.
- The UNIX-based commands in this document are case sensitive. Pay particular attention to the upper and lower cases shown in the examples when entering commands.

**0 GENERAL**

1. Connect the laptop or workstation to the slot\_2 NMIC and log in as the root user via a telnet session.

```
telnet [IP address of the slot_2 NMIC]
```

2. Create a directory on both NMICs called /tmp/p3 and manually ftp the kernel image, OS package, and feature control package to this directory on both NMICs. All other release 3.0 packages including all software images and flash images should already be on the NMIC disk in the appropriate directories.

3. Install the fallback OS on both NMICs.

```
/sbin/cwupgrade /tmp/p3/ADC-Linux-fallback-3.0.1.0.ppc.rpm
```

4. Install the appropriate 3.0 Feature Control package on both NMICs.

```
/sbin/cwupgrade /tmp/p3/FeatureControl-a(x)-3.0-1.ppc.rpm
```

## 11 FLASH FALLBACK

5. Perform the following steps for each NE in the ring:
    - Invoke the Flash Upgrade screen in the GUI on the slot\_2 NMIC.
    - Select release 3.0 boot images for each card in the shelf and press the 'Apply' button.
    - Execute a hard reset on each card immediately following successful download. Note that this can be **traffic affecting**, so you should take similar steps as done in software upgrade. See that procedure for details.
- **Note:** If the procedure is aborted anytime after flash fallback, you should reinstall release 3.1 flash for all cards.

## 12 SOFTWARE FALLBACK

6. Start the fallback procedure on the slot\_4 NMIC (the standby NMIC). This step invokes a graphical procedure that walks you through the fallback steps for this NMIC. At the end of the procedure, all Cellworx application processes are killed. Keep the telnet session open, though, because the standby NMIC needs to be manually rebooted following active NMIC fallback.
  - **cd /cellworx/bin**
  - **./cw\_swfallback -s 3.0.1.0**
7. After standby NMIC upgrade completion, start the fallback procedure on the slot\_2 NMIC (the active NMIC). This step invokes a graphical procedure that walks you through the necessary steps for reverting software for the entire ring. These steps are identical to software upgrade except you will be loading release 3.0 software into the offline memory banks for each card in each NE instead of release 3.1 software.
  - **cd /cellworx/bin**
  - **./cw\_swfallback -a 3.0.1.0**

As with software upgrade, you will need to periodically click the 'Refresh' button to determine when each card has downloaded the designated release 3.0 software image. When all cards for all NEs have downloaded the image, each entry in the main screen will read, "NE is eligible for switchover." At this point, click the 'Next >>' button to continue with the procedure and restore the release 3.0 databases. Note that these databases are currently in the /cellworx/config directory with the extension, ".release3.0". At the end of the procedure, the slot\_2 NMIC is automatically rebooted.
8. Following slot\_2 NMIC reboot, start the CellworxVision GUI on the slot\_2 NMIC.

**DLP-798**

Page 3 of 3

9. Reboot the slot\_4 NMIC by using `/sbin/reboot`. When this NMIC reboots, a database restoration window will appear in the slot\_2 NMIC GUI. **It's very important that you select "Slot 2" for database restoration because only the databases on the slot\_2 NMIC were restored from release 3.1 to release 3.0.**

**Stop! You have completed this procedure.**

## **TROUBLESHOOTING GUIDELINES**

### **PHILOSOPHY OF MAINTENANCE**

The maintenance philosophy is built on the system signal flow from the Ring Interface Card (RIC) through the backplane and out the Access Interface cards or Electrical Interface Modules (EIMs). Since the Cellworx STN is an active interconnecting device, there are active components to troubleshoot and module, cable, or fiber removal may be necessary.

### **Trouble Analysis Procedures**

Trouble analysis procedures found in this document involve obtaining alarm and status reports via craft or GUI sessions. Status and alarm reports are then analyzed to determine proper system operation and problem isolation.

### **Electrostatic Discharge (ESD) Considerations**

Modules can be damaged by static electricity that builds up in work areas, especially in areas with low relative humidity. The static buildup in work areas, on work surfaces, personnel, and their clothing is produced by the rubbing of objects together to produce an electrical charge.

The greatest potential for ESD damage occurs in areas with low relative humidity. All personnel handling modules should take the following precautions.

1. Keep materials that tend to generate static electricity such as plastics, nylon clothing, and Styrofoam containers away from all modules.
2. Read all caution and warning labels on bags and shipping cartons before opening any package.
3. Open all modules, using properly grounded wrist straps and table mats designed to dissipate static electricity.
4. If possible, wait to remove modules from their protective anti-static packaging until it is time to install them into a chassis.
5. Never touch module components or connector pins. Handle all modules only by the front plate, extractor, or by the card edges.



**TAP-100**

Page 2 of 23

6. When opening modules or working on a chassis always wear a grounded wrist strap.
7. Ensure that all modules removed from the chassis or not installed, are properly stored in anti-static packing material.
8. The Cellworx STN shelf is equipped with a grounding jack for connecting anti-static grounding wrist straps. The jack is located on the front right side of the shelf .



**Caution:** *Modules can be damaged by static electrical discharge. Before handling any modules, Electrostatic Discharge precautions (ESD) must always be used. Ensure that all modules removed from the chassis or not installed are properly stored in anti-static packing material. When working with modules, always place the module on an electrically grounded approved anti-static mat.*

**ALARM TROUBLESHOOTING**

**Summary:** This section provides the user and maintenance personnel with a table of definitions for all alarm messages that can be generated by the Cellworx STN system. Also provided are suggestions for troubleshooting the alarms incurred during system operation.

A general knowledge of how the Cellworx STN functions and what alarm indications mean will aid in troubleshooting tasks. The following assumptions are made by this procedure:

- All Cellworx STNs in the network are properly equipped.
  - There may be a single cause for multiple alarms or trouble indications.
  - Only a single failure exists.
1. Accumulate the alarm information from the system to determine the highest level of alarm, and which node is generating the alarm.

**Reference:** NTP-007.

2. Locate the retrieved alarm message in Table 4-1 and refer to the suggested course of action provided. The alarms are listed alphabetically in bold and the actual TRAP messages are listed below the alarm message.

Table 4-1. Alarm Identifications, continued

ALARM MESSAGE	SEVERITY	IMPACT	DESCRIPTION	SUGGESTED COURSE OF ACTION
<b>Alarm Indication Signal Line</b> AIS-L	Minor	Service Affecting	The line level has an alarm indication signal present. TX AIS generally informs the user that the card has lost its input at the AIC, RX AIS informs the user that the card is receiving AIS from the far end which has lost its input at the AIC.	Check input source/connections and facility status. AIS is detected when the line has trouble.
<b>Alarm Indication Signal Path</b> AIS-P	Minor	Service Affecting	Generally informs the user that the transmitting LTE has lost its input at the AIC. TX AIS generally informs the user that the card has lost its input at the AIC, RX AIS informs the user that the card is receiving AIS from the far end which has lost its input at the AIC.	Check input source/connections and facility status.
<b>Burst Errored Second Threshold Crossing Alert</b> BESTca	Informational Alert	Not Service Affecting	DSX1 alarm: A burst of errored seconds at the T1 level has exceeded the threshold setting.	Check input source signal level and pulse mask, increase threshold level if needed.
<b>Card Inserted</b> CardInserted	Informational Alert	Maintenance	Card is inserted into backplane slot. Informs user that a card is physically present.	No action necessary.
<b>Card Removed</b> CardRemoved	Minor	Maintenance	Informs user that the card has been removed from the backplane.	Locate card and reinstall if necessary, otherwise, delete the card and facility from database. Refer to NTP-006 section B.
<b>Card Type Mismatch</b> CardTypeMismatch	Informational Alert	Installation Error	Informs user that the inserted card type is different from previous card type for that slot. A different card type may have been inserted into the wrong slot.	Verify slot configuration and replace card with valid type. If changing configuration, delete previous configuration data for that slot and change out the EIM at the rear of the shelf if necessary.

(continued)

TAP-100  
Page 4 of 23

Table 4-1. Alarm Identifications, continued

ALARM MESSAGE	SEVERITY	IMPACT	DESCRIPTION	SUGGESTED COURSE OF ACTION
<b>C-bit Coding Violations Threshold Crossing Alert</b> CCVTca	Informational Alert	Service Degradation	T3 C-bit coding violations threshold crossing alert.	System is most likely experiencing a line condition deterioration. Check signal level and pulse mask at input. Also verify LBO setting at CPE end.
<b>C-bit Errored Seconds Threshold Crossing Alert</b> CESTca	Informational Alert	Service Degradation	T3 C-bit errored seconds threshold crossing alert.	System is most likely experiencing a line condition deterioration. Check signal level and pulse mask at input. Also verify LBO setting at CPE end.
<b>C-bit Severely Errored Seconds Threshold Crossing Alert</b> CSESTca	Informational Alert	Service Degradation	T3 C-bit severely errored seconds threshold crossing alert. Port in alarm has received excessive errored seconds beyond user specified threshold.	System is most likely experiencing a line condition deterioration. Check signal level and pulse mask at input. Also verify LBO setting at CPE end.
<b>Cellbus Parity Threshold Crossing Alert</b> CellbusParityTca	Major – currently an informational alert.	Not service affecting.	Parity errors on the cell bus have exceeded the user definable threshold level.	Very likely the backplane bus is bad. Shelf may need to be replaced.
<b>Channel Mismatch</b> ChannelMismatch	Minor	Installation Error	Channel number mismatch in the SONET K1 and K2 byte. Informs user that the facilities fibers are not installed properly.	Verify working and protect fibers are not crossed, and/or proper connectivity to EPS shelves.

(continued)

Table 4-1. Alarm Identifications, continued

ALARM MESSAGE	SEVERITY	IMPACT	DESCRIPTION	SUGGESTED COURSE OF ACTION
<b>Code Violation Line Far End Threshold Crossing Alert</b> CV-LFETca	Informational Alert	Service Degradation	Coding violations threshold crossing alert for line layer at far end. A bit of information has changed in the transmission to the far end target NE causing Line Code Violations (CVL) that have exceeded the user definable threshold level. Should be accompanied by a CVS in the network.	Retrieve PM reports to check for Section Code Violations (CVS) which identify problem cards/ports. Check input levels and signal sources. Increase threshold settings if necessary. Check local requirements for proper levels.
<b>Code Violation Line Threshold Crossing Alert</b> CV-Ltca	Informational Alert	Service Degradation	Coding violations threshold crossing alert for line layer. A bit of information has changed in the transmission from the far end originating LTE, causing Line Code Violations (CVL) that have exceeded the user definable threshold level. Should be accompanied by a CVS in the network.	Retrieve PM reports to check for Section Code Violations (CVS) which identify problem cards/ports. Check input levels and signal sources. Increase threshold settings if necessary. Check local requirements for proper levels.
<b>Code Violation Path Far End Threshold Crossing Alert</b> CV-PFETca	Informational Alert	Service Degradation	CV threshold crossing alert for path layer at far end. A bit of information has changed in the path layer transmission to the far end causing far end Path Code Violations (CVP) that have exceeded the user definable threshold level.	Retrieve PM reports to check for Section Code Violations (CVS) for problem cards/ports. Check input levels and signal sources. Increase threshold settings if necessary. Check local requirements for proper levels.
<b>Code Violation Path Threshold Crossing Alert</b> CV-Ptca	Informational Alert	Service Degradation	Coding violations for path layer. A bit of information has changed in the path layer transmission from the far end causing local PTE path code violations (CVP) that have exceeded the user definable threshold level.	Retrieve PM reports to check for Section Code Violations (CVS) for problem cards/ports. Check input levels and signal sources. Increase threshold settings if necessary. Check local requirements for proper levels.

(continued)

TAP-100  
Page 6 of 23

Table 4-1. Alarm Identifications, continued

ALARM MESSAGE	SEVERITY	IMPACT	DESCRIPTION	SUGGESTED COURSE OF ACTION
<b>Code Violation Threshold Crossing Alert</b> CV-Stca	Informational Alert	Service Degradation	Coding violation threshold crossing alert for section layer. A bit of information has changed in the transmission from the previous STE causing Section Code Violations (CVS) that have exceeded the user definable threshold level. Causes a CVL at the line terminating equipment.	Check input levels and signal sources. Increase threshold settings if necessary. Check local requirements for proper levels.
<b>Configuration Failure</b> ConfigurationFailure	Minor – currently an informational alert	Installation Error	A request to configure a card or port has failed.	Check configuration status, verify physical equipment is available and try again.
<b>Control Slip Seconds Threshold Crossing Alert</b> CSSTca	Informational Alert	Service Degradation	DSX1 alarm: The timing Release is changing too much.	Check timing source signal.
<b>CRC Threshold Crossing Alert</b> CRCErrortca	Informational Alert	Service Degradation	Cyclic Redundancy Check has errors that have exceeded user definable levels.	T1 frames may be bad at the far end or near end. Check signal inputs and line levels.
<b>Degraded Minutes Threshold Crossing Alert</b> DegradMinuteTca	Informational Alert	Service Degradation	The input signal power level has dropped over a user definable amount of time.	Check power level at input, verify cleanliness of fiber connections, adjust attenuator if equipped, and check transmit end output power level and replace card if necessary.

(continued)

Table 4-1. Alarm Identifications, continued

ALARM MESSAGE	SEVERITY	IMPACT	DESCRIPTION	SUGGESTED COURSE OF ACTION
<b>Discard Header Error Count Violation Threshold Crossing Alert</b> DiscardHecVioThresholdExceeded	Informational Alert	Service Degradation	Cells discarded due to Header Error Checksum have crossed the user definable threshold setting causing a Threshold crossing alert (TCA).	Could be caused by a port failure at any ATM interface. Verify the port is online, check configuration, look for indications of high BER (Bit Error Rate), increase threshold settings if necessary, use line loopback to troubleshoot path through port.
<b>EIM Removed</b>	Informational Alert	Service Degradation	EIM has physically been pulled from the backplane.	Install EIM card as needed.
<b>Egress Congestion High Threshold Crossing Alert</b> EgressCongestHighTca	Informational Alert	Service Degradation	Cells congested on the egress of reported port have crossed a user definable threshold level.	Review traffic contracts and modify threshold level if needed. Monitor for future congestion alarms. Cells tagged for discard become susceptible to termination.
<b>Endpoint Alarm Indication Signal</b> EndpointAIS	Minor	Service Affecting	Endpoint of reported connection is receiving AIS code due to a failure somewhere in the connection path.	Check connection originating point by retrieving connection status and using OAM loopback from test equipment. Check input at the Electrical Interface Module (EIM) and the facility status on the Access Interface Card (AIC).
<b>Endpoint Loss of Clock</b> EndpointLOC	Minor	Service Affecting	No ATM cell traffic is present at connection endpoint.	Perform ATM loopback to verify path continuity through port.
<b>Endpoint Remote Defect Indication</b> EndpointRDI	Minor	Service Affecting	Endpoint remote defect indication. AIS is detected by the remote endpoint causing an RDI.	Check the AIC and EIM that feed the traffic for the connection.

(continued)

Table 4-1. Alarm Identifications, continued

ALARM MESSAGE	SEVERITY	IMPACT	DESCRIPTION	SUGGESTED COURSE OF ACTION
<b>Errored Seconds Line Far End Threshold Crossing Alert</b> ES-LFETca	Informational Alert	Service Degradation	Errored seconds violations threshold crossing alert for line layer at far end. A one second interval in the transmission to the far end target NE has had an error at the line layer causing an Errored Second Line (ESL). ESL errors have exceeded the user definable threshold level.	Retrieve PM reports to check for Errored Seconds Section Violations (ESS) which identify problem cards/ports across the network. Check input levels and signal sources. Increase threshold settings if necessary. Check local requirements for proper levels.
<b>Errored Seconds Line Threshold Crossing Alert</b> ES-Ltca	Informational Alert	Service Degradation	Errored seconds violations threshold crossing alert for line layer at local NE. A one second interval in the transmission from the far end originating NE has had an error at the line layer causing an Errored Second Line (ESL). ESL errors have exceeded the user definable threshold level (OC-N interface only).	Retrieve PM reports to check for Errored Seconds Section Violations (ESS) which identify problem cards/ports across the network. Increase threshold settings if necessary. Check local requirements for proper levels.
<b>Errored Seconds Path Far End Threshold Crossing Alert</b> ES-PFETca	Informational Alert	Service Degradation	Errored seconds violations threshold crossing alert for path layer at far end. A one second interval in the transmission to the far end target NE has had an error at the path layer causing an Errored Second Path (ESP). ESP errors have exceeded the user definable threshold level (OC-N interface only).	Retrieve PM reports to check for Errored Seconds Section Violations (ESS) which identify problem cards/ports across the network. Check input levels and signal sources. Increase threshold settings if necessary. Check local requirements for proper levels.
<b>Errored Seconds Path Threshold Crossing Alert</b> ES-Ptca	Informational Alert	Service Degradation	ES violations threshold crossing alert for path layer at local NE. A one second interval in the transmission from the far end originating NE has had an error at the path layer causing an Errored Second Path (ESP). ESP errors have exceeded the user definable threshold level.	Retrieve PM reports to check for Errored Seconds Section Violations (ESS) which identify problem cards/ports across the network. Check input levels and signal sources. Increase threshold settings if necessary. Check local requirements for proper levels.

(continued)

Table 4-1. Alarm Identifications, continued

ALARM MESSAGE	SEVERITY	IMPACT	DESCRIPTION	SUGGESTED COURSE OF ACTION
<b>Errored Seconds Section Threshold Crossing Alert</b> ES-Stca	Informational Alert	Service Degradation	ES violations threshold crossing alert for section layer at local NE. A one second interval in the transmission from the far end originating NE has had an error at the section layer causing an Errored Second Section (ESS). ESS errors have exceeded the user definable threshold level.	Check input levels and signal sources. Increase threshold settings if necessary. Check local requirements for proper levels.
ESTca <b>Errored Seconds Threshold Crossing Alert</b>	Informational Alert	Service Degradation	Errored seconds threshold crossing alert for reported port.	Check input levels and signal sources. Increase threshold settings if necessary. Check local requirements for proper levels.
<b>Excessive Ber</b>	Critical	Service Affecting	Excessive Bit Error Rate count.	Applies to all SONET cards.
<b>Extended Cell Layer Cell Bus Interface Fault</b> EclCellbusInterfaceFault <b>Extended Cell Layer Egress Router Fault</b> EclEgressRouterFault <b>Extended Cell Layer Ingress Router Fault</b> EclIngressRouterFault <b>Extended Cell Layer Utopia Interface Fault</b> EclUtopiaInterfaceFault	Major	Service Affecting	Cell bus hard failure.	Each of these alarms indicate a switch fabric failure. Check alarm messages, is the failure on both buses? One card? All cards? If single card failure, remove from backplane, check pins in backplane connector, and reseat. One card failure could pull down the entire bus. Pull each card out one at a time starting with protect, check the pins in the backplane connector, monitor system traffic for recovery, then reseat the card. Perform switch over via GUI or craft interfaces before pulling EIMs if necessary. Do not pull the working cards. Repeat procedure for SC TEIM in slot 18 at the rear of the shelf. This is a bus termination and the system will crash without it.
<b>Far End Loss Of Signal</b> LOS-FE	Critical	Service Outage	No input signal is being provided at the far end.	Check input connections at the far end and transmitting equipment into the far end low speed facility.

(continued)



Table 4-1. Alarm Identifications, continued

ALARM MESSAGE	SEVERITY	IMPACT	DESCRIPTION	SUGGESTED COURSE OF ACTION
<b>Far End Loss Of Signal</b> LOS-FE	Critical	Service Outage	No input signal is being provided at the far end.	Check input connections at the far end and transmitting equipment into the far end low speed facility.
<b>Far End Protection Line Failure</b> FarEndProtLineFailed	Minor – currently an informational alert.	Service Affecting	Far end protection line is no longer available.	Check fiber facilities and connections to protect card. Verify Protection EIMs (PEIM) are installed. Check facility status and alarm reports.
<b>Fifteen Minute Interval, Errored Seconds Threshold Crossing Alert</b> EESCMajor15minTca	Informational Alert	Service Degradation	Exceeded errored seconds have crossed a user definable major or minor threshold crossing alert for a 15 minute period causing an alarm report.	Retrieve PM data to determine problem cards/ports. Check inputs and signal levels. Replace problem cards if necessary. See Section 6 of this manual for warranty and return authorization information.
<b>Housekeeping Alarm X</b> HouseKeepingAlarm"X"	Minor	Not Service Affecting	X = input numbers 1 to 8. User defined housekeeping input on port listed has received an alarm.	Refer to label inside front door panel for correlating input type. Troubleshoot accordingly..
<b>Ingress Congestion Threshold Crossing Alert</b> IngressCongestTca	Informational Alert	Service Degradation	Ingress congestion threshold crossing alert. Cells congested on the ingress of reported port have crossed a user definable threshold level.	Review traffic contracts and modify threshold level if needed. Monitor for future congestion alarms. Cells tagged for discard become susceptible to termination.
<b>Line Code Violations Threshold Crossing Alert</b> LCVTca	Informational Alert	Service Degradation	Line code violations have exceeded the user definable threshold level causing a Threshold Crossing Alert (Tca).	Check input from Customer premise Equipment (CPE), signal level and pulse mask.

(continued)

Table 4-1. Alarm Identifications, continued

ALARM MESSAGE	SEVERITY	IMPACT	DESCRIPTION	SUGGESTED COURSE OF ACTION
<b>Line Errored Seconds Threshold Crossing Alert</b> LESTca	Informational Alert	Service Degradation	A one second interval in the transmission from the far end originating NE has had an error at the line layer causing an Errored Second Line (ESL). ESL errors have exceeded the user definable threshold level.	Check input from Customer premise Equipment (CPE) (signal level and pulse mask).
<b>Login Failure Threshold Crossing Alert</b> FailedLoginTca	Informational Alert	Not Service Affecting.	A user has entered the wrong information to gain access in excess of user defined thresholds.	Administrator should check user name and password or verify personnel authorization to access system.
<b>Loss of Cell Delineation</b> LCD	Critical / Major on RIC	Service Outage except for RIC cards.	System unable to determine or delineate between incoming cells.	Reset SC cards at shelf. Replace if necessary. See Section 6 of this manual for warranty and return authorization information.
<b>Loss of Frame</b> LOF	Critical Major on RIC	Service Outage except for RIC cards.	T3 frame cannot be obtained or synced to.	Retrieve facility configuration and check framing. Verify it matches CPE transmission.
<b>Loss of Pointer Path</b> LOP-P	Critical Major on RIC	Service Outage except for RIC cards.	Card cannot locate the payload due to a loss of pointer at the path layer.	Retrieve SONET facility configuration and check the clock source.
<b>Loss of Signal</b> LOS	Critical Major on RIC	Service Outage except for RIC cards.	No input signal is being provided.	Check input connections and transmitting equipment.
<b>Loss of Sync</b>	Minor	Service Affecting		Applies to all SONET cards.
<b>Mode Mismatch</b> ModeMismatch	Minor	Installation Error	Protection mode received in K1 and K2 bytes does not match configured mode. SONET interfaces only.	Check each facility and verify the protection modes match (i.e., unidirectional versus bidirectional or 1:N versus 1+1).

(continued)

TAP-100  
Page 12 of 23

Table 4-1. Alarm Identifications, continued

ALARM MESSAGE	SEVERITY	IMPACT	DESCRIPTION	SUGGESTED COURSE OF ACTION
<b>Module Failure without protection</b> ModuleFail	Critical	Service Outage / RICs have outage only on dual failure.	Card failure or card malfunction.	Reset the card via software, reseal the card to reboot it. If it does not return to service, replace the card. Call ADC for warranty information and return authorization.
<b>Module Failure Stand-by Ring Interface Card (RIC)</b> ModuleFail	Major	Not Service affecting. RICs have outage only on dual failure.	Card failure or card malfunction.	Reset the card via software, reseal the card to reboot it. If it does not return to service, replace the card. Call ADC for warranty information and return authorization.
<b>Module Failure with protection</b> ModuleFail	Minor	Not service affecting.	Card failure or card malfunction.	Reset the card via software, reseal the card to reboot it. If it does not return to service, replace the card. Call ADC for warranty information and return authorization.
<b>NE Power Failure (A)</b> Power“X”Failure (X = A or B)	Critical – currently an informational alert.	Service Outage	An input power failure on either the A side, or B side of the shelf.	Check power supplies, breakers, and fuses. Investigate if anything in the equipment caused a breaker trip or blown fuse. Verify proper ratings for current draw.
<b>New SONET Path Trace</b> NewPathTrace	Informational Alert	Not Service Affecting	New SONET path trace has been received.	Informs the user that a new path trace has been established in the network, probably a new connection. No action necessary.
<b>Optical Laser Failure</b> LaserFail	Critical/ Major on RIC	Service Outage except on RIC cards.	Optical LASER failure at card/port reported in alarm message.	May try resetting or reseating card but generally a hard failure. Replace card. See Section 6 of this manual for warranty and return authorization information.

(continued)

Table 4-1. Alarm Identifications, continued

ALARM MESSAGE	SEVERITY	IMPACT	DESCRIPTION	SUGGESTED COURSE OF ACTION
<b>Out Of Cell Delineation Threshold Crossing Alert</b> OCDThresholdExceeded	Informational Alert	Installation Error	Can indicate line degradation.	Could be caused by a port failure at any ATM interface. Verify the port is online, check configuration, look for indications of high BER (Bit Error Rate), increase threshold settings if necessary, use line loopback to troubleshoot path through port.
<b>Path Coding Violations Threshold Crossing Alert</b> PCVTca	Informational Alert	Service Degradation	T3 P-bit coding violations threshold crossing alert.	Path code violations indicate a parity mismatch in the SONET or DSX path. Examine the physical circuit to determine if there are any impairments.
<b>Payload Label Mismatch Path</b> PLM-P	Minor	Installation Error	Traffic in payload does not match what the payload label in the path layer expected.	Check input source type and change payload label if needed.
<b>P-bit Errored Seconds Threshold Crossing Alert</b> PESTca	Informational Alert	Service Degradation	T3 P-bit errored seconds threshold crossing alert. A one second interval in the transmission from the far end originating NE has had excessive parity errors. PES errors have exceeded the user definable threshold level.	Parity bits on the incoming DS3 line. The transmitted signal does not match the received signal.
<b>P-bit Severely Errored Seconds Threshold Crossing Alert</b> PSESTca	Informational Alert	Service Degradation	T3 P-bit Severely Errored Seconds (SES) threshold crossing alert. Excessive one second intervals in the transmission from the far end originating NE have had Parity bit errors. P-Bit SES errors have exceeded the user definable threshold level.	Parity bits on the incoming DS3 line. The transmitted signal does not match the received signal at an error rate of 1.6E-5 or worse for a period of time less than ten seconds.

(continued)

TAP-100  
Page 14 of 23

Table 4-1. Alarm Identifications, continued

ALARM MESSAGE	SEVERITY	IMPACT	DESCRIPTION	SUGGESTED COURSE OF ACTION
<b>Physical Layer Convergence Protocol Loss of Frame</b> PLCP-Lof	Critical	Service Affecting	PLCP encoding problem at the far end, or line degradation.	Check far end encoding and line levels.
<b>Physical Layer Convergence Protocol Severely Errored Framing Seconds Threshold Crossing Alert</b> PLCP-SEFSTca	Informational Alert	Service Degradation	PLCP severely errored frame seconds threshold crossing alert.	The TCAs signal a problem with the integrity of the PLCP overhead in the DS3 frame. The most probable cause is a mismatch between the transmitter and the receiver. Examine the physical circuit to determine if there are any impairments.
<b>Physical Layer Convergence Protocol Unavailable Seconds Threshold Crossing Alert</b> PLCP-UASTca	Informational Alert	Service Degradation	PLCP unavailable seconds threshold crossing alert.	An error rate of 1.6E-5 or worse for a period of time more than ten seconds. Examine the physical circuit to determine if there are any impairments.
<b>Physical Layer Convergence Protocol Yellow Alarm</b> PLCP-YellowAlarm	Minor	Installation Error	PLCP yellow alarm. Remote end has detected a PLCP Loss of Frame (LOF).	PLCP Yellow alarm indicates to the near end a problem with the framing in the PLCP header at the far end. Examine the physical circuit to determine if there are any impairments.

(continued)

Table 4-1. Alarm Identifications, continued

ALARM MESSAGE	SEVERITY	IMPACT	DESCRIPTION	SUGGESTED COURSE OF ACTION
<b>Primary Derived DS1 Source Failed</b>	Major	Not Service Affecting	The reference source for the primary clock has failed.	Check source (external, optical in, or other AIC card) for alarms and correct as necessary.
<b>Protection Switch Bytes Failure</b> ProtectionSwitchBytesFailure	Minor	Installation Error	Inconsistent APS byte or invalid code.	Automatic Protection Switch (APS) byte is inconsistent with the expected code. Check facility interconnections and verify switching modes match at each end (i.e., 1:1, 1+1, 1:N).
<b>Protection Switch Failure</b> ProtSwitchFailed	Minor – currently an information alert.	Installation Error	User initiated or automatic protection switch failed.	Check protection group for previously failed/switched working card, lockout of protect, or failed protect card. PEIM must be installed at the rear of the shelf at the protection slot for 1:N protection groups.
<b>Protection Switch Successful</b> ProtSwitchSuccessful	Informational	Not Service Affecting	Protection switch completed successfully.	User initiated or automatic protection switch was completed. No action necessary.
<b>Protocol Error Threshold Crossing Alert</b> ProtocolErrorTca	Informational Alert	Service Degradation	Protocol error threshold has been crossed.	Caused by the following: 1) Out of range VPI/VCI, (2) Invalid PTI values (6 and 7), and 3) Unassigned VPI/VCI values. Check the connection VPI/VCI to make sure the provisioning is correct for the expected traffic stream..
<b>Remote Failure Indication</b> RFI	Major	Service affecting	Far end has detected AIS at the DSX level.	RFI is a near end notification of a remote failure. For example, a LOS occurs at the near end, a RFI line and path is sent in the reverse direction to the remote node. An RFI line is sent if the network element is a line terminating element while a RFI path is sent if the network element is a path terminating element.

(continued)

TAP-100  
Page 16 of 23

Table 4-1. Alarm Identifications, continued

ALARM MESSAGE	SEVERITY	IMPACT	DESCRIPTION	SUGGESTED COURSE OF ACTION
<b>Remote Failure Indication Line</b> RFI-L	Major	Service affecting.	SONET far end has detected an AIS-L condition.	See above.
<b>Remote Failure Indication Path</b> RFI-P	Major – currently an informational alert.	Service affecting	Far end has detected an AIS-P condition.	See above..
<b>Secondary Derived DS1 Source Failed</b>	Major	Not service affecting	The reference source for the secondary clock has failed.	Check source (external, optical in, or other AIC card) for alarms and correct as necessary.
<b>Severely Errored Frame Seconds Threshold Crossing Alert</b> SEFS-tca	Informational Alert	Service Degradation	DSX Severely errored frame seconds threshold crossing alert.	The incoming signal frame has an error rate of 1.6E-5 or worse for a period of time less than ten seconds. An SES can also be caused by a physical failure such as LOS for less than ten seconds. Examine the physical circuit to determine if there are any impairments.
<b>Severely Errored Frame Seconds Section Threshold Crossing Alert</b> SEFS-Stca	Informational Alert	Service Degradation	Severely errored frame seconds threshold crossing alert for section layer.	The incoming signal frame has an error rate of 1.6E-5 or worse for a period of time less than ten seconds. An SES can also be caused by a physical failure such as LOS for less than ten seconds. Examine the physical circuit to determine if there are any impairments.
<b>Severely Errored Seconds Line Far End Threshold Crossing Alert</b> SES-LFETca	Informational Alert	Service Degradation	Severely errored seconds threshold crossing alert for line layer at far end.	The far end line has an error rate of 1.6E-5 or worse for a period of time less than ten seconds. An SES can also be caused by a physical failure such as LOS for less than ten seconds. Examine the physical circuit to determine if there are any impairments.

(continued)

Table 4-1. Alarm Identifications, continued

ALARM MESSAGE	SEVERITY	IMPACT	DESCRIPTION	SUGGESTED COURSE OF ACTION
<b>Severely Errored Seconds Line Threshold Crossing Alert</b> SES-Ltca	Informational Alert	Service Degradation	Severely errored seconds threshold crossing alert for line layer.	The incoming signal line has an error rate of 1.6E-5 or worse for a period of time less than ten seconds. An SES can also be caused by a physical failure such as LOS for less than ten seconds. Examine the physical circuit to determine if there are any impairments.
<b>Severely Errored Seconds Path Far End Threshold Crossing Alert</b> SES-PFETca	Informational Alert	Service Degradation	Severely errored seconds threshold crossing alert for path layer at far end.	The far end NE has a path error rate of 1.6E-5 or worse for a period of time less than ten seconds. An SES can also be caused by a physical failure such as LOS for less than ten seconds. Examine the physical circuit to determine if there are any impairments.
<b>Severely Errored Seconds Path Threshold Crossing Alert</b> SES-Ptca	Informational Alert	Service Degradation	Severely errored seconds threshold crossing alert for path layer.	The incoming signal path has an error rate of 1.6E-5 or worse for a period of time less than ten seconds. An SES can also be caused by a physical failure such as LOS for less than ten seconds. Examine the physical circuit to determine if there are any impairments.
<b>Severely Errored Seconds Section Threshold Crossing Alert</b> SES-Stca	Informational Alert	Service Degradation	Severely errored seconds threshold crossing alert for section layer. Excessive one second intervals in the transmission from the far end NE have had ES In the section layer over and above the ES threshold level causing a Severely Errored Seconds threshold alert.	The incoming signal section has an error rate of 1.6E-5 or worse for a period of time less than ten seconds. An SES can also be caused by a physical failure such as LOS for less than ten seconds. Examine the physical circuit to determine if there are any impairments.
<b>Shelf Controller Card's Database Corrupted</b> DBCrupted	Informational Alert	Installation Error	Memory problem on the SC card.	Reset the SC card to initiate a new load from the NMIC by either hitting the reset and enable buttons simultaneously, or reset via software command.

(continued)



TAP-100  
Page 18 of 23

Table 4-1. Alarm Identifications, continued

ALARM MESSAGE	SEVERITY	IMPACT	DESCRIPTION	SUGGESTED COURSE OF ACTION
<b>Shelf Controller EIM 1 Removed</b> EIMSlot1Removed	Informational Alert	Installation Information	SC EIM in slot one which provides hardwired alarm inputs and outputs, remote ACO activation, and timing reference inputs (BITS), cannot be found .	Buses are probably not functioning properly because the Bus Terminating EIM (B-TEIM) in slot 18 at the rear of the shelf or the SC in slot 1 has been physically removed from the backplane.
<b>Shelf Controller EIM 18 Removed</b> EIMSlot18Removed	Informational Alert	Installation Information	SC EIM in slot 18 which provides backplane bus termination, Telnet connection to the node, and shelf addressing, has been physically pulled from the backplane.	Buses are probably not functioning properly because the Bus Terminating EIM (B-TEIM) in slot 18 at the rear of the shelf or the SC in slot 18 has been physically removed from the backplane.
<b>Signal Degraded</b>	Minor	Could be Service Affecting.	Input signal strength is degraded. Possibly a fiber problem or transmitter.	Check fiber path for damage or bends and check attenuation and transmitter output.
<b>Software Downloading Failed</b> SWDownloadFailed	Informational Alert	Installation Information	NMIC unable to download software successfully to the NE.	Check FTP connection and NE status.
<b>Sync Message Changed</b> SyncMessageChanged	Major – currently an informational alert.	Installation Error	SONET sync message (S1 byte) changed.	No suggestions.
<b>Sync Reference Failure</b> SyncReferenceFailed	Major – currently an informational alert.	Service Affecting	Timing reference that the network element clocks off of has failed.	Retrieve timing source information and check reference input (BITS, 622-RIC, 155-CRS).
<b>T1 Loopback</b> DS1Loopback	Informational Alert	Service Affecting	T1 Loopback Pseudo Random Pattern. Indicates a loopback condition has been initiated by a user.	Check for troubleshooting activity by other users and release loopback if necessary.
<b>T1 Yellow Alarm</b> DS1Rai	Minor	Not service affecting	DSX1 Alarm: Remote Alarm Indication. Indicates a problem at the CPE transmitter.	Check card and output level of CPE equipment. Replace as needed per local practices.

(continued)

Table 4-1. Alarm Identifications, continued

ALARM MESSAGE	SEVERITY	IMPACT	DESCRIPTION	SUGGESTED COURSE OF ACTION
<b>T3 Loopback</b> DS3Loopback	Informational Alert	Service Affecting	T3 Loopback Indication. Indicates a loopback condition has been initiated by a user which causes a T3 RAI.	Check for troubleshooting activity by other users and release loopback if necessary.
<b>T3 Remote Alarm Indication</b> DS3Rai	Minor	Not service affecting	T3 Remote Alarm Indication or yellow alarm. CPE equipment is receiving a yellow alarm at T3 port.	Check EIM connections, signal level and pulse mask.
<b>Twenty Four Hour Interval, Errored Seconds Threshold Crossing Alert</b> EESCMajor24hTca	Informational Alert	Service Degradation	Exceeded errored seconds have crossed a user definable major or minor threshold crossing alert for a 24 hour period causing an alarm report.	Retrieve PM data to determine problem cards/ports. Check inputs and signal levels. Replace problem cards if necessary. See Section 6 of this manual for warranty and return authorization information.
<b>Unavailable Seconds Line Far End Threshold Crossing Alert</b> UAS-LFETca	Informational Alert	Service Degradation	Unavailable seconds threshold crossing alert for line layer at far end. Line layer was unavailable at the far end network element for more seconds than the threshold was set for. UAS overrides all other error counts.	Check input and transmitter at local node.
<b>Unavailable Seconds Line Threshold Crossing Alert</b> UAS-LTca	Informational Alert	Service Degradation	Unavailable seconds threshold crossing alert for line layer. Line layer was unavailable for more seconds than the threshold was set for. UAS overrides all other error counts.	Check input and transmitter at far end node.
<b>Unavailable Seconds Path Far End Threshold Crossing Alert</b> UAS-PFETca	Informational Alert	Service Degradation	Unavailable seconds threshold crossing alert for path layer at far end. Path layer was unavailable at the far end network element for more seconds than the threshold was set for. UAS overrides all other error counts.	Check input source and transmitter at local node.

(continued)

TAP-100

Page 20 of 23

Table 4-1. Alarm Identifications, continued

ALARM MESSAGE	SEVERITY	IMPACT	DESCRIPTION	SUGGESTED COURSE OF ACTION
<b>Unavailable Seconds Path Threshold Crossing Alert</b> UAS-PTca	Informational Alert	Service Degradation	Unavailable seconds threshold crossing alert for path layer. Path layer was unavailable for more seconds than the threshold was set for. UAS overrides all other error counts.	Check input source and transmitter at far end node.
<b>Unavailable Seconds Threshold Crossing Alert</b> UASTca	Informational Alert	Service Degradation	T3 unavailable seconds threshold crossing alert. T3 signal was unavailable for more seconds than the threshold was set for. UAS overrides all other error counts.	Check input source.

1. After determining the alarm type, locate the associated interface in Figure-1 below to determine each alarm type origination point in an NE.

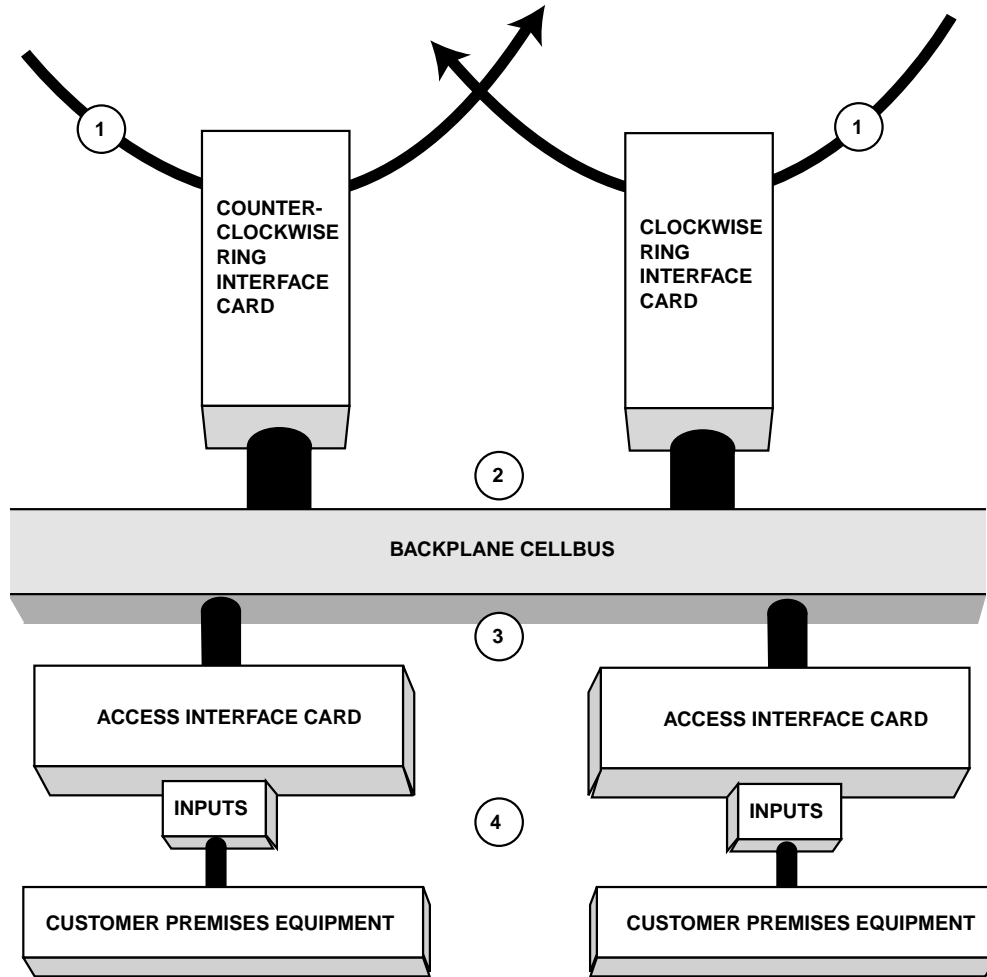

1. INCOMING OPTICAL SIGNAL CARRYING ALARM INDICATION, BAD DATA FROM REMOTE END, OR IS MISSING.
- 2.. PROBLEM WITH RIC SWITCH FABRIC OR BACKPLANE CONNECTION.
3. PROBLEM WITH AIC CARD SWITCH FABRIC, BACKPLANE CONNECTION, VP/VC CONFIGURATION, OR EIM BACKPLANE CONNECTIONS.
4. CPE TRANSMITTING ERROR OR ALARM MESSAGE, BAD CONNECTION, BAD INPUT SIGNAL, OR PORT CONFIGURATION.

11757-B

Figure-1. NE Flowchart Troubleshooting Guide

## A. NMIC GENERATED ALARMS

Table 101-2. Alphabetical NMIC Generated Alarm Reports

ALARM MESSAGE	SEVERITY	IMPACT	DESCRIPTION	SUGGESTED COURSE OF ACTION
NE Added	Informational Alert	Not Service Affecting	An NE has been added to the Ring via user command in GUI.	Informational message, no action is necessary.
NE Booted	Informational Alert	Not Service Affecting	An NE has completed the boot process either from user initiated reset, or an NE being established.	Informational message, no action is necessary.
NE Isolated	Critical	Service Outage	NMIC can not communicate with the NE indicated. May be fiber related failure (cut), SC communications failure. In the event of an SC failure, the cell traffic may still continue to/from the NE.	Use OAM loopbacks if necessary to check cell traffic to/from the node. No loopbacks may be performed at the isolated mode until it recovers. At the location of the isolated node, check optical cards for indications of LOS. If LOS is not present, management cells are not being processed at the node. Reset SC card, replace if necessary.
NE Removed	Informational Alert	Not Service Affecting	An NE has been removed from the Ring via user command in GUI.	Informational message, no action is necessary.
NMIC Administratively Locked for Maintenance	Informational Alert	Not Service Affecting	This informational message appears when a database restoration is attempted. It locks out user activity until restoration is completed.	No action necessary.
NMIC Administratively Unlocked	Informational Alert	Not Service Affecting	This informational message appears when a database restoration has completed successfully. Indicates NMIC is ready for processing user requests.	No action necessary.
NMIC Disk Usage Threshold Exceeded	Informational Alert	Not Service Affecting	Informational alarm appears when disk usage reaches 50% and again at 80%.	Check disk files for spurious alarm messages that are affecting disk space.
NMIC File Replication Failure	Minor	Not Service Affecting.	NMIC failed to copy selected files to the stand-by NMIC.	Check statuses of NMICs and retry replication.

(continued)

Table 101-2. Alphabetical NMIC Generated Alarm Reports, continued

ALARM MESSAGE	SEVERITY	IMPACT	DESCRIPTION	SUGGESTED COURSE OF ACTION
NMIC Full Database Restoration Failed	Minor	Not Service Affecting.	Informs user that the NMIC database restoration attempt has failed.	Check statuses of NMICs and reattempt database restoration.
NMIC Full Database Restoration Needed	Informational Alert	Not Service Affecting	Informs user that the NMIC cards (working and protect) are out of sync.	Perform a database restoration to synchronize the information on the NMIC cards. Refer to DLP-719.
NMIC lost connection with NMIC application	Informational Alert	Not Service Affecting	Informs user that the NMIC had a failure resulting in a loss of connection with its application.	This event will result in a protection switch if the second NMIC is in sync and protection switching is enabled.
NMIC lost connection with NMIC resources agent	Informational Alert	Not Service Affecting	Informs user that the NMIC had a failure resulting in a loss of connection with its resource agent.	This event will result in a protection switch if the second NMIC is in sync and protection switching is enabled.
NMIC lost connection with peer NMIC	Informational Alert	Not Service Affecting	Working NMIC cannot communicate with the protection NMIC.	Protection switching will not be enabled at this point. Try reseating standby NMIC. May need to perform a database restoration upon reestablishing communication paths.
NMIC Protection Change Notification	Informational Alert	Not Service Affecting	An informational alert informing the user that the protection mode has been changed. This may be due to a Lockout or an Automatic Protection Switch (APS) being initiated.	No action necessary. Verify the protection operation change is required and revert back if it is not.
NMIC Protection Switch Notification	Informational Alert	Not Service Affecting	An informational alert indicating the NMIC has started the process of switching to the protect card.	No action necessary. Verify card switches properly upon completion.
Physical Fiber Failure	Major	Not service affecting	Network has experienced a failure on one of the fiber interconnections between the nodes, indicated on the GUI screen as an orange connection.	Check NE alarm reports at each end of the fiber. Any LOS or Section AIS on the hop may cause this alarm.
Second NMIC Plugged into Invalid Slot	Informational Alert	Not Service Affecting	Informs the user that the protection NMIC is not seated into the proper slot in the backplane.	Remove the protection NMIC and reinstall into slots 4 and 5.

## SECTION 3: GENERAL INFORMATION

Content	Page
1 WARRANTY/SOFTWARE	3-1
2 REPAIR/ADVANCE REPLACEMENT POLICY	3-1
3 REPAIR CHARGES	3-2
4 REPLACEMENT/SPARE PRODUCTS	3-2
5 RETURNED MATERIAL	3-2
6 CUSTOMER INFORMATION AND ASSISTANCE	3-3

### .1. WARRANTY/SOFTWARE

The Product and Software warranty policy and warranty period for all Products of ADC Telecommunications, Inc. (hereinafter referred to as ADC) is published in ADC's Warranty/Software Handbook. Contact the Business Broadband Group (BBG) Technical Assistance Center at 1-800-366-3891, extension 54878 (in U.S.A. or Canada) 1-972-680-4878 (outside U.S.A. and Canada) for warranty or software information or for a copy of the Warranty/Software Handbook.

### .2. REPAIR/ADVANCE REPLACEMENT POLICY

All repairs of ADC Products must be done by ADC or an authorized representative. Any attempt to repair or modify ADC Products without prior written authorization from ADC shall void ADC's warranty.

If a malfunction cannot be resolved by the normal troubleshooting procedures, call the BBG Technical Assistance Center at 1-800-366-3891, extension 54878 (in U.S.A. or Canada) or 1-972-680-4878 (outside U.S.A. and Canada). A telephone consultation can sometimes resolve a problem without the need to repair or replace the ADC Product.

If, during a telephone consultation, ADC determines the ADC Product requires repair, ADC will authorize the return of the affected Product by the issue of a Return Material Authorization number and complete return shipping instructions. If service is affected, ADC can arrange to ship a replacement Product when available from designated inventory. In all cases, the defective Product must be carefully packaged to eliminate damage, and returned to ADC in accordance with issued ADC instructions.

### **.3. REPAIR CHARGES**

If the defect and the necessary repairs are covered by warranty, Buyer's only obligation is the payment of all transportation and associated costs in returning the defective Product to the location designated by ADC. ADC, at its option, will either repair or replace the Product at no charge and return the Product to Buyer with transportation costs paid by ADC, only when ADC contracted carriers are used. Requested return of Product by any other means will be at Buyer's cost. Buyer is responsible for all other associated costs in return of Products from ADC. If Product is Out of Warranty or NTF (no trouble found), ADC will charge a percentage of the current Product list price. To obtain the percentage factor for Out of Warranty or NTF Product, contact the ADC Product Return Department at 1-800-366-3891, extension 63748 (in U.S.A. or Canada) or 612-946-3748 (outside U.S.A. and Canada).

If a service affecting advance replacement Product is requested, the current list price of a new Product will be charged initially. A customer purchase order is required to ship an advance replacement Product. Upon receipt of the defective Product, there will be no credit issued by ADC to the buyer for any returned Product found to be Out of Warranty. ADC will credit buyer eighty percent (80%) of Product price charged for any In Warranty Product under the Program terms. Products must be returned within thirty (30) days to be eligible for any advance replacement credit. If repairs necessitate a field visit by an ADC representative, customer authorization (purchase order) must be obtained prior to dispatching a representative, ADC will charge the current price of a field visit plus round trip transportation charges from Minneapolis to the customer's site.

### **.4. REPLACEMENT/SPARE PRODUCTS**

Replacement parts, including but not limited to button caps and lenses, lamps, fuses, and patch cords, are available from ADC on a special order basis. Contact the NSD Technical Assistance Center at 1-800-366-3891, extension 54878 (in U.S.A. or Canada) or 972-680-4878 (outside U.S.A. and Canada) for additional information.

Spare Products and accessories can be purchased from ADC. Contact Sales Administration at 1-800-366-3891, extension 63748 (in U.S.A. or Canada) or 612-946-3748 (outside U.S.A. and Canada) for a price quote and to place your order.

### **.5. RETURNED MATERIAL**

Contact the ADC Product Return Department at 1-800-366-3891, extension 63748 (in U.S.A. or Canada) or 1-952-946-3748 (outside U.S.A. and Canada) to obtain a Return Material Authorization number prior to returning an ADC Product.

All returned Products must have a Return Material Authorization (RMA) number clearly marked on the outside of the package. The Return Material Authorization number is valid for thirty (30) days from authorization.



## .6. CUSTOMER INFORMATION AND ASSISTANCE

For customers wanting information on ADC products or help in using them, ADC offers the services listed below. To obtain any of these services by telephone, first dial the central ADC telephone number, then dial the extension provided below.

The central number for calls originating in the U.S.A. or Canada is **1-800-366-3891**. For calls originating outside the U.S.A. or Canada, dial country code "1" then dial **952-946-3000**.

<b>Sales Assistance</b> <b>Extension 3000</b>	<ul style="list-style-type: none"> <li>• Quotation Proposals</li> <li>• Ordering and Delivery</li> <li>• General Product Information</li> </ul>
<b>Systems Integration</b> <b>Extension 63000</b>	<ul style="list-style-type: none"> <li>• Complete Solutions (from Concept to Installation)</li> <li>• Network Design and Integration Testing</li> <li>• System Turn-Up and Testing</li> <li>• Network Monitoring (Upstream or Downstream)</li> <li>• Power Monitoring and Remote Surveillance</li> <li>• Service/Maintenance Agreements</li> <li>• Systems Operation</li> </ul>
<b>BATG Technical Assistance Center</b> <b>Extension 54878</b> <b>E-Mail: <a href="mailto:batgtac@adc.com">batgtac@adc.com</a></b> <b>972-680-4878</b>	<ul style="list-style-type: none"> <li>• Technical Information</li> <li>• System/Network Configuration</li> <li>• Product Specification and Application</li> <li>• Training (Product-Specific)</li> <li>• Installation and Operation Assistance</li> <li>• Troubleshooting and Repair/Field Assistance</li> </ul>
<b>Product Return Department</b> <b>Extension 63748</b> <b>E-Mail: <a href="mailto:repair&amp;return@adc.com">repair&amp;return@adc.com</a></b>	<ul style="list-style-type: none"> <li>• ADC Return Authorization number and instructions must be obtained before returning products.</li> </ul>

Product information may also be obtained using the ADC web site at **[www.adc.com](http://www.adc.com)** or by writing ADC Telecommunications, Inc., P.O. Box 1101, Minneapolis, MN 55440-1101, U.S.A.

Contents herein are current as of the date of publication. ADC reserves the right to change the contents without prior notice. **In no event shall ADC be liable for any damages resulting from loss of data, loss of use, or loss of profits and ADC further disclaims any and all liability for indirect, incidental, special, consequential or other similar damages. This disclaimer of liability applies to all products, publications and services during and after the warranty period.**

This publication may be verified at any time by contacting ADC's Technical Assistance Center at 1-800-366-3891, extension 54878 (in U.S.A. or Canada) or 972-680-3223 (outside U.S.A. and Canada), or by writing to ADC Telecommunications, Inc., Attn: Technical Assistance Center, Mail Station #77, P.O. Box 1101, Minneapolis, MN 55440-1101, U.S.A.



© 2000, ADC Telecommunications, Inc.  
 All Rights Reserved  
 Printed in U.S.A.

## Free Manuals Download Website

<http://myh66.com>

<http://usermanuals.us>

<http://www.somanuals.com>

<http://www.4manuals.cc>

<http://www.manual-lib.com>

<http://www.404manual.com>

<http://www.luxmanual.com>

<http://aubethermostatmanual.com>

Golf course search by state

<http://golfingnear.com>

Email search by domain

<http://emailbydomain.com>

Auto manuals search

<http://auto.somanuals.com>

TV manuals search

<http://tv.somanuals.com>