

# USER MANUAL



## **ThinMux Chassis**

Product Catalog: ACE-COM L1

Part Number: 150-2263-01

CLEI: VAMXHN0F



## Revision History of Manual

To order copies of this document, use document catalog number LTPH-UM-1088-02.

Issue	Release Date	Revisions Made
1	June 22, 2001	Initial release.
2	January 3, 2002	Update to reflect install, wiring, and setup only.

## Copyright

January 3, 2002

© 2002 ADC DSL Systems, Inc. All rights reserved.

## Trademark Information

*ADC is a registered trademark of ADC Telecommunications, Inc. No right, license, or interest to such trademarks is granted hereunder, and you agree that no such right, license, or interest shall be asserted by you with respect to such trademark.*

*Other product names mentioned in this practice are used for identification purposes only and may be trademarks or registered trademarks of their respective companies.*

## Disclaimer of Liability

*Information contained in this document is company private to ADC DSL Systems, Inc., and shall not be modified, used, copied, reproduced or disclosed in whole or in part without the written consent of ADC.*

*Contents herein are current as of the date of publication. ADC reserves the right to change the contents without prior notice. In no event shall ADC be liable for any damages resulting from loss of data, loss of use, or loss of profits, and ADC further disclaims any and all liability for indirect, incidental, special, consequential or other similar damages. This disclaimer of liability applies to all products, publications and services during and after the warranty period.*

*similar damages. This disclaimer of liability applies to all products, publications and services during and after the warranty period.*

## USING THIS MANUAL

The following conventions are used in this manual:

- Monospace type indicates screen text.
- Keys you press are indicated by small icons such as **Y** or **ENTER**. Key combinations to be pressed simultaneously are indicated with a plus sign as follows: **CTRL** + **ESC**.
- Items you select are in **bold**.

Three types of messages, identified by icons, appear in text.



**Notes contain information about special circumstances.**



**Cautions indicate the possibility of personal injury or equipment damage.**



**The Electrostatic Discharge (ESD) symbol indicates that a device or assembly is susceptible to damage from electrostatic discharge.**

## UNPACK AND INSPECT YOUR SHIPMENT

Upon receipt of the equipment:

- Unpack each container and inspect the contents for signs of damage. If the equipment has been damaged in transit, immediately report the extent of damage to the transportation company and to ADC. Order replacement equipment, if necessary.
- Check the packing list to ensure complete and accurate shipment of each listed item. If the shipment is short or irregular, contact ADC as described in [“Appendix C - Product Support” on page 19](#). If you must store the equipment for a prolonged period, store the equipment in its original container.

## SAFETY WARNINGS AND NOTICES



The ThinMux chassis DC power supply feeds must be connected to either (1) -48 Vdc Safety Extra Low Voltage (SELV) sources or (2) -48 Vdc sources that are electrically isolated from the AC sector and reliably connected to earth. The source's fault current capacity shall be lower than 50A, or an appropriate overcurrent protection rated 5A, must be provided on each -48 Vdc conductor. The overcurrent protection can also be used as a cutoff switch if another disconnect device is not installed.



This equipment may be provided with a module that incorporates laser source(s). Refer to the module's documentation for detailed safety information.



The telemetry I/O must be connected to either a SELV source or an ELV source that is electrically isolated from the AC sector and reliably connected to earth.



The metallic telecommunication interface should not leave the building premises unless connected to telecommunication devices providing primary and secondary protection.

# TABLE OF CONTENTS

<b>Overview</b> .....	<b>1</b>
Features .....	1
Backplane .....	2
<b>External Interfaces</b> .....	<b>3</b>
T1/E1 Interface .....	3
T1/E1 Test Interface .....	3
RS-232 Craft Interface .....	4
10/100BASE-T Ethernet Interface .....	4
Discrete Alarms .....	4
Battery Supply .....	5
<b>Installation</b> .....	<b>5</b>
Mounting the Chassis .....	6
Installing the Fan Module (FB1) .....	7
Wiring the Common Access Panel .....	8
Connect a BITS Timing Source .....	8
Connect Test Access .....	9
Connect Alarms .....	10
Connecting Power .....	10
Installing DS3 or STS-1 Interface Cables .....	11
<b>Appendix A - Pin Assignments</b> .....	<b>14</b>
T1/E1 Interface .....	14
RS-232 Craft Interface .....	17
10/100BASE-T Ethernet Interface .....	17
<b>Appendix B - Specifications</b> .....	<b>18</b>
<b>Appendix C - Product Support</b> .....	<b>19</b>

**Appendix D - Abbreviations** ..... 20

**Certification and Warranty** ..... **Inside Back Cover**

## LIST OF FIGURES

1. Backplane Interfaces (rear view) ..... 2

2. ThinMux Chassis in a CO Rack ..... 6

3. Installing the Fan Module (FB1) ..... 7

4. Wire-Wrap Pin Positions/Common Access Panel (rear view) ..... 8

5. Installing Line Terminators ..... 9

6. Battery Supply Connector (rear view) ..... 10

7. DS3 or STS-1 Shelf Configuration ..... 12

8. Male Cable Connector Into Female Backplane Connector ..... 14

## LIST OF TABLES

1. T1/E1 Receive Pin Assignments ..... 14

2. T1/E1 Transmit Pin Assignments ..... 16

3. RS-232 Craft Interface Pin Assignments ..... 17

4. Ethernet 10/100BASE-T Pin Assignments ..... 17

## LIST OF FIGURES

1. Backplane Interfaces (rear view) .....	2
2. ThinMux Chassis in a CO Rack.....	6
3. Installing the Fan Module (FB1).....	7
4. Wire-Wrap Pin Positions/Common Access Panel (rear view).....	8
5. Installing Line Terminators.....	9
6. Battery Supply Connector (rear view) .....	10
7. DS3 or STS-1 Shelf Configuration .....	12
8. Male Cable Connector Into Female Backplane Connector .....	14

## LIST OF TABLES

1. T1/E1 Receive Pin Assignments .....	14
2. T1/E1 Transmit Pin Assignments .....	16
3. RS-232 Craft Interface Pin Assignments .....	17
4. Ethernet 10/100BASE-T Pin Assignments .....	17





## LIST OF TABLES

1. T1/E1 Receive Pin Assignments .....	14
2. T1/E1 Transmit Pin Assignments .....	16
3. RS-232 Craft Interface Pin Assignments .....	17
4. Ethernet 10/100BASE-T Pin Assignments .....	17



# OVERVIEW

The ADC® ThinMux™ chassis houses the ThinMux DS3 or ThinMux STS-1 multiplexer and fits in a Central Office (CO) rack. Each type of multiplexer provides support for a minimum of 28 T1 (or 21 E1) lines from the chassis. The chassis also provides two DS3 interfaces for external equipment. It features a forced-air cooling unit, Ethernet port, rear craft port, craft ports on the multiplexer front panels, and fiber management guides. Offering a 1+1 protected multiplexing function on the network and client side, the ThinMux chassis is the industry's most compact multiplexer platform.

## FEATURES

- The ThinMux chassis allows for the following shelf configurations:
  - STS-1 to 28 T1 (using ThinMux multiplexer HXU-359)
  - DS3 to 28 T1 or 21 E1 lines (using ThinMux multiplexer HXU-360)
- Dual multiplexer support for 1+1 protection of network and customer interfaces
- Migration path and investment protection on installed equipment
- Concentration of many low-speed access network interfaces to a single high-speed network interface
- Industry-standard 64-pin T1 (or E1) connectors enable rapid installation
- Craft port access for easy configuration
- Field-serviceable forced-air cooling unit

Depending on your network interface requirements, several cabling options are available. Select the instructions that apply to your configuration as shown in [“Installing DS3 or STS-1 Interface Cables”](#) on page 11.

# BACKPLANE

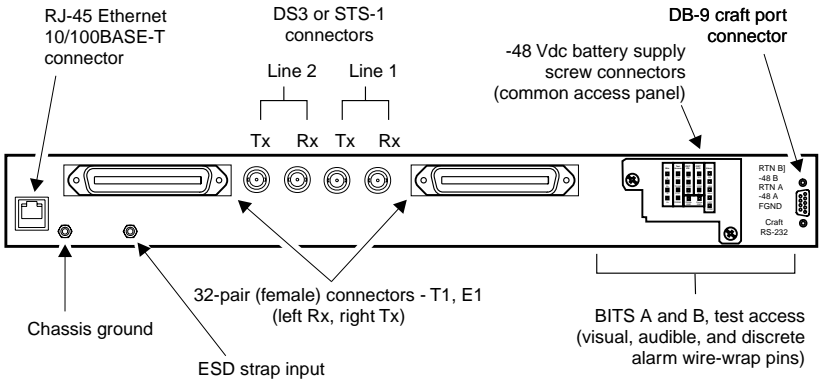

**Figure 1.** Backplane Interfaces (rear view)

The ThinMux chassis provides a compact 1U platform for the ThinMux family of multiplexers with the following interconnects:

- One 10/100BASE-T Ethernet (IEEE 802.3)
- Two 64-pin female receptacle connectors for T1/E1 transmit/receive, chassis-shielded
- Four 75Ω BNC connectors for DS3/STS-1 transmit/receive
- Four wire-wrap 0.045-inch pins for Building Integrated Timing Supply (BITS) A and B
- Four wire-wrap 0.045-inch pins for T1 or E1 test access, transmit/receive
- Four wire-wrap 0.045-inch pins for Visible (VIS) and Audible (AUD) alarms (dry relay contacts) which are normally open (NO) discrete alarms
- Five wire-wrap 0.045-inch pins for discrete alarms (solid state relay contacts): Far End, Minor, Major, and Critical
- Five screw connectors for -48V dual power
- One DB-9 connector for RS-232 communication

# EXTERNAL INTERFACES

The ThinMux chassis provides the following interfaces:

- T1/E1
- T1/E1 Test
- RS-232
- 10/100BASE-T Ethernet
- Discrete alarms

## T1/E1 INTERFACE

There are two female 32-pair connectors to access 28 T1 (or 21 E1) lines for intra-building connection; no protection is provided on the backplane. One connector is for transmission, the other is for reception. Each port is routed to both multiplexers (A and B) for transmit and receive. See [“Appendix A - Pin Assignments”](#) on page 14 for interface pinout description.



**A shielded 32-pair cable should be used and grounded at either the frame or chassis. The ground connection is done at one end of the cable only to avoid ground loops.**

## T1/E1 TEST INTERFACE

The four-wire test interface can be routed to any of the 28 T1 (or 21 E1) low-speed T1/E1 ports. It can be used to monitor the line or to look toward the network or subscriber drop. The four signals are accessed through four 0.045-inch wire-wrap pins. (For more information about the wire-wrap pins, see [“Connect Test Access”](#) on page 9.)

## RS-232 CRAFT INTERFACE

Communication with the ThinMux STS-1 and ThinMux DS3 central processors occur through a standard grounded DB-9 connector (RS-232 Data Communication Equipment interface).

Signals are routed to both multiplexers, and the transmitter of the inactive multiplexer remains in a tristate mode. Pin 5 is the digital ground of all digital components (both multiplexers). See [Table 3 on page 17](#) for interface pinout description.

## 10/100BASE-T ETHERNET INTERFACE

Communication with the multiplexer (STS-1 or DS3) central processors occurs through the standard grounded RJ-45 10/100BASE-T interface for metallic chassis. Similar to the RS-232 interface, signals are routed to both multiplexers; the transmitter of the inactive multiplexer remains in a tristate mode. See [Table 4 on page 17](#) for interface pinout description.

## DISCRETE ALARMS

In addition to the various interfaces supplied by the ThinMux chassis, the common access panel (see [Figure 4 on page 8](#)) provides access for discrete alarm wiring.

The discrete alarms connection is provided by 0.045-inch wire-wrap pins located on the rear of the chassis (see [Figure 1 on page 2](#)). The signals are routed to the multiplexers, where the logic functions are performed. Critical VIS and AUD alarms comprise dry contacts for telemetry applications. The alarms have an independent common connection (serial COM port) to relays; normally open (NO) is provided. Current is limited to 0.5A when a maximum temperature rise of 20°C on traces is desired (as per MIL-STD-275C).

When using a legacy HXU-358 multiplexer, the CRIT VIS, CRIT AUD, and Alarm pins must be left unconnected. For all other multiplexers, these pins may be used as needed.

Other alarms (FE, MIN, MAJ, and CRIT) share the same COM, and only normally open contact is provided as shown in [Figure 4 on page 8](#). Contact closure is made using a solid-state relay photo Metal-Oxide Semiconductor

Field-Effect Transistor (MOSFET). When set to ON, resistance is  $35\Omega$  at  $85^{\circ}\text{C}$  (worst case). The switched current must be less than 80 mA, and the switched voltage must be less than 135V. If a coil relay or other inductive load is used, a protection diode must be connected between the alarm signal and the COM signal to prevent damage to the solid state relay. ADC does not provide the diode with the ThinMux chassis. The diode must be purchased separately. Use Motorola diode part number 1N4004 or equivalent.

## BATTERY SUPPLY

The battery supply terminals are located on the rear of the chassis under the common access panel (see [Figure 1 on page 2](#)). Five AWG 16 wires connect the Return B, -48B, Return A, -48A, and Frame Ground to the power source. To wire power A and B inputs, attach A and B power leads from the fuse panel or office battery to the appropriate screw connector on the terminal block. For more information, refer to [“Connecting Power” on page 10](#).

## INSTALLATION



**Before installing the ThinMux Chassis, visually check its packaging to ensure that it has sustained no shipping damage. Immediately report any damage to the shipping agent. See [“Appendix C - Product Support” on page 19](#).**

## MOUNTING THE CHASSIS

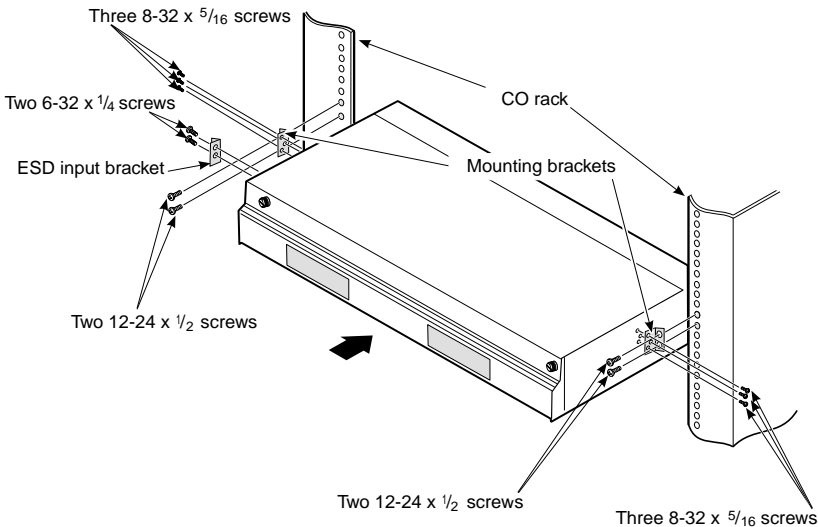

**Figure 2.** *ThinMux Chassis in a CO Rack*

- 1 Install a mounting bracket on each side of the ThinMux chassis using the three screws provided for each bracket (8-32 x  $\frac{5}{16}$  screws) as shown in [Figure 2](#). (Mounting brackets and screws are contained in the installation kit.)



**Two sets of mounting brackets are supplied to fit 19-inch or 23-inch racks with standard EIA-hole spacing ( $\frac{1}{2}$  inch).**

**Optional brackets with WECO-hole spacing (1 inch) are available (ACE-MK1).**

- 2 Install ESD input bracket on front left side of the chassis.
- 3 Align the chassis mounting bracket holes with the rack's vertical mounting holes. Mount the chassis in the rack. Install two 12-24 x  $\frac{1}{2}$  screws in each bracket and secure the chassis to the rack.



## INSTALLING THE FAN MODULE (FB1)

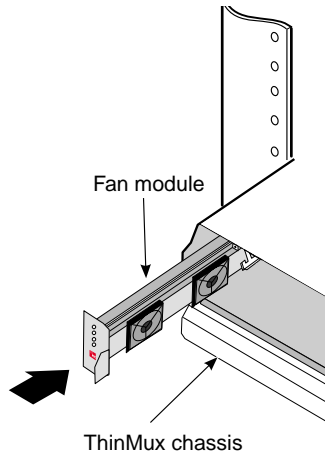
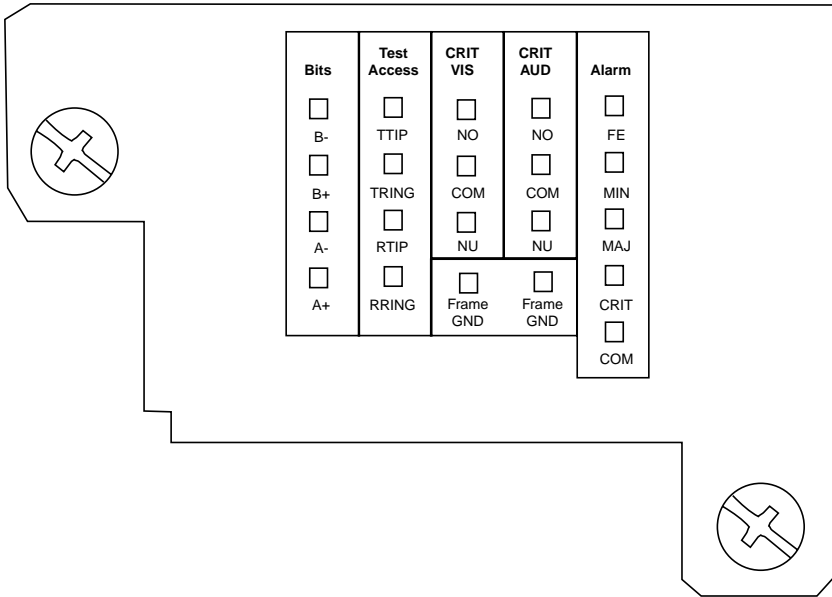

**Figure 3.** *Installing the Fan Module (FB1)*

- 1 Unwrap the enclosed fan module.
- 2 Align the fan with the slot located on the left side of the chassis and slide the fan in as shown in [Figure 3](#).
- 3 Insert the fan module until the connector is firmly seated in the backplane.

# WIRING THE COMMON ACCESS PANEL

- 1 Unscrew the common access panel hold-down lugs and remove the cover (see [Figure 4](#)).

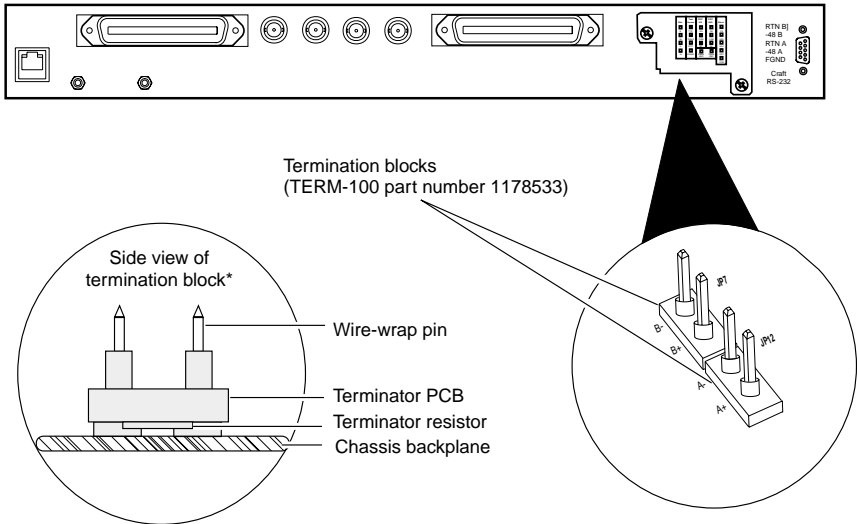

**Figure 4.** Wire-Wrap Pin Positions/Common Access Panel (rear view)

## Connect a BITS Timing Source

- 2 Determine if you require a BITS timing source connection to the chassis; if so, the chassis must first have a line termination prior to chassis connection.

The BITS concept is used for interoffice synchronization distribution. Each line source, Bits A and Bits B, must be terminated. ADC provides this termination through external termination blocks (product catalog TERM-100) placed on wire-wrap terminal posts on the rear of the ThinMux chassis as shown in [Figure 5 on page 9](#).



**Figure 5.** *Installing Line Terminators*

- 3 Install the BITS terminating blocks (catalog number TERM-100), provided in the installation kit, between the Bits A+, A- and B+, B- posts.
- 4 Connect Bits A and Bits B posts to your Synchronous Optical Network (SONET) clock synchronization source (SONET minimum clock or better). Use a frame ground post as a shield, if needed.

## Connect Test Access

- 5 Connect the Test Access TTIP, TRING, RTIP, RING, and Frame GND posts to the external test head.

## Connect Alarms

- 6 Connect the alarm relay wires from the CO alarm center to the posts of the Visible Alarm (CRIT. VIS—NO and COM), Audible Alarm (CRIT. AUD—NO and COM) and Alarm (FE, MIN, MAJ, CRIT, and COM). Follow the CO site instructions for connecting alarm relays. The visible and audible alarm relays do not have an NC (normally closed) position.
- 7 Connect a 16 AWG chassis ground cable to the ground (GND) post.

## CONNECTING POWER



The fuse rating for the ThinMux chassis is 2A.

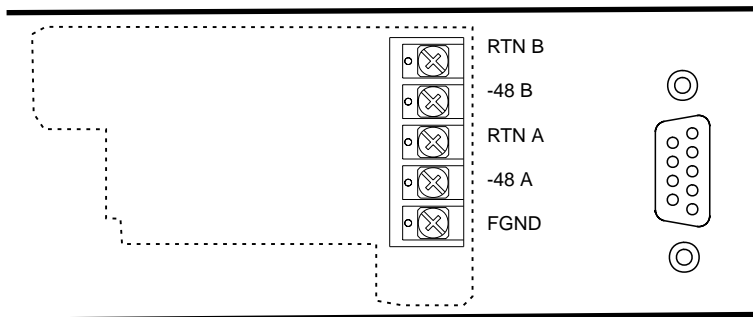

**Figure 6.** Battery Supply Connector (rear view)

- 1 Connect 16 AWG cables to the -48V A, B, and RTN terminals.
- 2 Connect the other end of the cables to CO battery supply and RTN terminals.
- 3 Apply power and check the voltage.
- 4 Reinstall the common access panel and screw in the hold-down lugs.



The ThinMux chassis DC power supply feeds must be connected to either (1) -48 Vdc Safety Extra Low Voltage (SELV) sources or (2) -48 Vdc sources that are electrically isolated from the AC sector and reliably connected to earth. The source's fault current capacity shall be lower than 50A, or an appropriate overcurrent protection, rated 5A, must be provided on each -48 Vdc conductor. The overcurrent protection can also be used as a cutoff switch if another disconnect device is not installed.



The ThinMux chassis is configured for redundant power. The A and B battery sources are independently connected to each multiplexer. In the event of a loss of power from one of the sources, an alarm is reported by the active multiplexer. Power is continually supplied to both slots in the chassis.

## INSTALLING DS3 OR STS-1 INTERFACE CABLES

After mounting the chassis to the CO rack, select the appropriate interface for cable installation. (For information regarding multiplexer configuration and operation, refer to the specific multiplexer user manual.)



**When installing components, wear an antistatic wrist strap. Avoid touching components on the circuit board.**

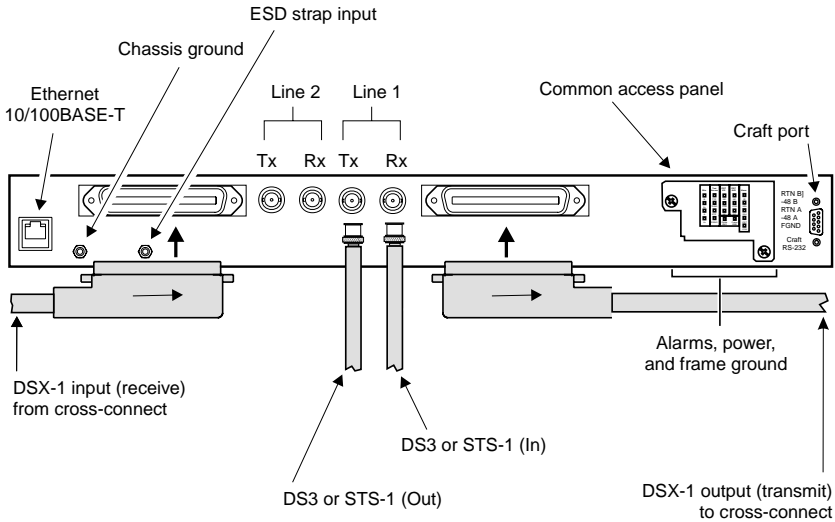

**Figure 7.** DS3 or STS-1 Shelf Configuration

- 1 Connect the 32-pair shielded cable, with amphenol male connector coming from the cross-connect, to the DSX-1 input (Rx) as shown in Figure 7.
- 2 Connect the 32-pair shielded cable, with amphenol male connector going to the cross-connect, to the DSX-1 output (Tx).



**The metallic telecommunication interface should not be routed from the building premises unless connected to telecommunication devices providing primary and secondary protection.**

- 3 Connect the DS3/STS-1 coaxial cable for data coming from the DS3/STS-1 network to Line 1 Rx.

- 4 Connect the DS3/STS-1 coaxial cable for data going to the DS3/STS-1 network to Line 1 Tx.
- 5 Connect the Ethernet port to a LAN, if required.
- 6 Connect a VT100 maintenance terminal to the craft port, if required.

# APPENDIX A - PIN ASSIGNMENTS

## T1/E1 INTERFACE

Figure 8 shows the male T1/E1 amphenol cable connector connecting to the female T1/E1 connector located on the backplane of the ThinMux chassis. Table 1 on page 14 and Table 2 on page 16 describe the pin assignments for transmit and receive.

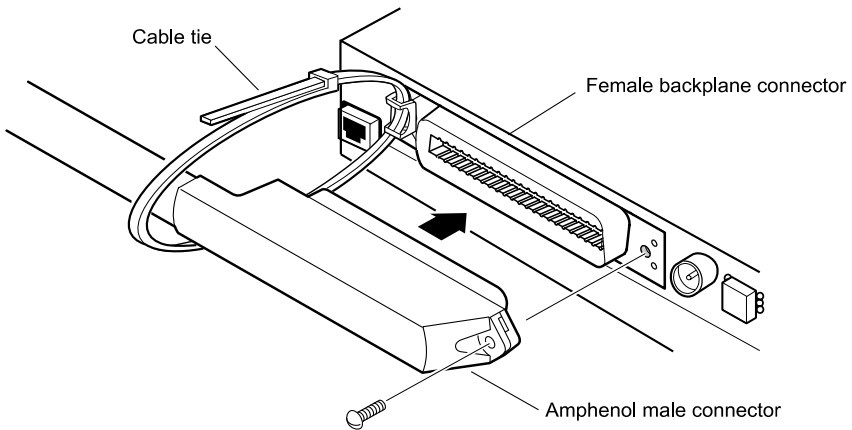

**Figure 8.** Male Cable Connector Into Female Backplane Connector

**Table 1.** T1/E1 Receive Pin Assignments

Pin Number	Description	Pin Number	Description
1	DSX_RX_RING1	33	DSX_RX_TIP1
2	DSX_RX_RING2	34	DSX_RX_TIP2
3	DSX_RX_RING3	35	DSX_RX_TIP3
4	DSX_RX_RING4	36	DSX_RX_TIP4
5	DSX_RX_RING5	37	DSX_RX_TIP5
6	DSX_RX_RING6	38	DSX_RX_TIP6

*Continued*



**Table 1.** *T1/E1 Receive Pin Assignments (Continued)*

<b>Pin Number</b>	<b>Description</b>	<b>Pin Number</b>	<b>Description</b>
7	DSX_RX_RING7	39	DSX_RX_TIP7
8	DSX_RX_RING8	40	DSX_RX_TIP8
9	DSX_RX_RING9	41	DSX_RX_TIP9
10	DSX_RX_RING10	42	DSX_RX_TIP10
11	DSX_RX_RING11	43	DSX_RX_TIP11
12	DSX_RX_RING12	44	DSX_RX_TIP12
13	DSX_RX_RING13	45	DSX_RX_TIP13
14	DSX_RX_RING14	46	DSX_RX_TIP14
15	DSX_RX_RING15	47	DSX_RX_TIP15
16	DSX_RX_RING16	48	DSX_RX_TIP16
17	DSX_RX_RING17	49	DSX_RX_TIP17
18	DSX_RX_RING18	50	DSX_RX_TIP18
19	DSX_RX_RING19	51	DSX_RX_TIP19
20	DSX_RX_RING20	52	DSX_RX_TIP20
21	DSX_RX_RING21	53	DSX_RX_TIP21
22	DSX_RX_RING22	54	DSX_RX_TIP22
23	DSX_RX_RING23	55	DSX_RX_TIP23
24	DSX_RX_RING24	56	DSX_RX_TIP24
25	DSX_RX_RING25	57	DSX_RX_TIP25
26	DSX_RX_RING26	58	DSX_RX_TIP26
27	DSX_RX_RING27	59	DSX_RX_TIP27
28	DSX_RX_RING28	60	DSX_RX_TIP28
29	N/C	61	N/C
30	N/C	62	N/C
31	N/C	63	N/C
32	N/C	64	Chassis Ground

**Table 2.** T1/E1 Transmit Pin Assignments

<b>Pin Number</b>	<b>Description</b>	<b>Pin Number</b>	<b>Description</b>
1	DSX_TX_RING1	33	DSX_TX_TIP1
2	DSX_TX_RING2	34	DSX_TX_TIP2
3	DSX_TX_RING3	35	DSX_TX_TIP3
4	DSX_TX_RING4	36	DSX_TX_TIP4
5	DSX_TX_RING5	37	DSX_TX_TIP5
6	DSX_TX_RING6	38	DSX_TX_TIP6
7	DSX_TX_RING7	39	DSX_TX_TIP7
8	DSX_TX_RING8	40	DSX_TX_TIP8
9	DSX_TX_RING9	41	DSX_TX_TIP9
10	DSX_TX_RING10	42	DSX_TX_TIP10
11	DSX_TX_RING11	43	DSX_TX_TIP11
12	DSX_TX_RING12	44	DSX_TX_TIP12
13	DSX_TX_RING13	45	DSX_TX_TIP13
14	DSX_TX_RING14	46	DSX_TX_TIP14
15	DSX_TX_RING15	47	DSX_TX_TIP15
16	DSX_TX_RING16	48	DSX_TX_TIP16
17	DSX_TX_RING17	49	DSX_TX_TIP17
18	DSX_TX_RING18	50	DSX_TX_TIP18
19	DSX_TX_RING19	50	DSX_TX_TIP19
20	DSX_TX_RING20	52	DSX_TX_TIP20
21	DSX_TX_RING21	53	DSX_TX_TIP21
22	DSX_TX_RING22	54	DSX_TX_TIP22
23	DSX_TX_RING23	55	DSX_TX_TIP23
24	DSX_TX_RING24	56	DSX_TX_TIP24
25	DSX_TX_RING25	57	DSX_TX_TIP25
26	DSX_TX_RING26	58	DSX_TX_TIP26
27	DSX_TX_RING27	59	DSX_TX_TIP27
28	DSX_TX_RING28	60	DSX_TX_TIP28
29	N/C	61	N/C
30	N/C	62	N/C
31	N/C	63	N/C
32	N/C	64	Chassis Ground

## RS-232 CRAFT INTERFACE

*Table 3. RS-232 Craft Interface Pin Assignments*

Pin Number	Description
1	NC
2	TX
3	RX
4	DSR
5	Digital ground
6	DTR
7	NC
8	NC
9	NC

## 10/100BASE-T ETHERNET INTERFACE

*Table 4. Ethernet 10/100BASE-T Pin Assignments*

Pin Number	Description
1	DATA_TRANSMIT+
2	DATA_TRANSMIT-
3	DATA_RECEIVE+
4	NC
5	NC
6	DATA_RECEIVE-
7	NC
8	NC

# APPENDIX B - SPECIFICATIONS

## Power

Input Voltage Range	-60 Vdc to -42.5 Vdc
Fusing	2A

## Environmental

Operating temperature	-40°F to +149°F (-40°C to +65°C)
Operating humidity	10% to 95%, non-condensing

## Dimensions

Height:	1.75 in.
Width:	17.35 in.
Depth:	12.0 in.
Weight:	< 10 lbs. (fully configured)

## Network Interfaces

DS3 and STS-1 (using a ThinMux multiplexer)

## Rear Panel Interfaces

DS3/STS-1	4 BNC, male
DS1/E1	32-pair shielded cable with amphenol male connector
Craft	DB-9 female
Ethernet/Telnet	RJ-45
Alarm Contacts	Wire-wrap pins, FE, MIN, MAJ, CRIT, COM (NO)
Audible Alarm	Wire-wrap pins, COM (NO)
Visible Alarm	Wire-wrap pins, COM (NO)
Test Access	Wire-wrap pins, TTIP, TRING, RTIP, RRING, Frame GND
Power	Dual screw terminals
Bits A and B	Wire-wrap pins A+, A-, B+, B-, shield, RtipA, RringA, RtipB, RringB, shield

# APPENDIX C - PRODUCT SUPPORT

ADC Customer Service Group provides expert pre-sales and post-sales support and training for all its products.

Technical support is available 24 hours a day, 7 days a week by contacting the ADC Technical Assistance Center (TAC).

---

## Sales Assistance

800.366.3891 ext. 73000 (USA and Canada) or 952.917.3000  
Fax: 952.917.3237

- Quotation Proposals
- Ordering and Delivery
- General Product Information

---

## Systems Integration

800.366.3891, ext. 73000 (USA and Canada) or 952.917.3000

- Complete Solutions (from concept to installation)
- Network Design and Integration Testing
- System Turn-Up and Testing
- Network Monitoring (upstream or downstream)
- Power Monitoring and Remote Surveillance
- Service/Maintenance Agreements
- Systems Operation

---

## BIA Technical Assistance Center

800.638.0031 or 714.730.3222  
Fax: 714.730.2400  
Email: [wsd\\_support@adc.com](mailto:wsd_support@adc.com)

- Technical Information
- System/Network Configuration
- Product Specification and Application
- Training (product-specific)
- Installation and Operation Assistance
- Troubleshooting and Repair/Field Assistance

---

## Online Technical Support

- [www.adc.com/Knowledge\\_Base/index.jsp](http://www.adc.com/Knowledge_Base/index.jsp)

---

## Online Technical Publications

- [www.adc.com/library1/](http://www.adc.com/library1/)

---

## Product Return Department

800.366.3891 ext. 73748 (USA and Canada) or 952.917.3748  
Fax: 952.917.3237  
Email: [repair&return@adc.com](mailto:repair&return@adc.com)

- ADC Return Material Authorization (RMA) number and instructions must be obtained before returning products.

---

*All 800 lines are toll-free in the USA and Canada.*

---

# APPENDIX D - ABBREVIATIONS

## A

**AWG:** American Wire Gauge

## B

**BITS:** Building Integrated Timing Supply

**BNC:** Bayonet-Locking Connector

## C

**CO:** Central Office

**COM:** Communications Port on a PC (serial port)

**CRIT:** Critical Alarm

## D

**DCE:** Data Communication Equipment

**DS3:** Digital Signal, Level 3

## E

**ELV:** Extra Low Voltage

**ESD:** Electrostatic Discharge

## F

**FE:** Far End

## L

**LAN:** Local Area Network

## M

**MAJ:** Major Alarm

**MIN:** Minor Alarm

**MOSFET:** Metal-Oxide Semiconductor Field-Effect Transistor

## N

**NO:** Normally Open

## R

**RX:** Receive

## S

**SELV:** Safety Extra Low Voltage

**STS:** Synchronous Transport Signal, Level 1

## T

**TX:** Transmit

---

# CERTIFICATION AND WARRANTY

## FCC CLASS A COMPLIANCE

This equipment has been tested and found to comply with the limits for a Class A digital device, pursuant to Part 15 of the FCC Rules. These limits are designed to provide reasonable protection against harmful interference when the equipment is operated in a commercial environment. This equipment generates, uses, and can radiate radio frequency energy and, if not installed and used in accordance with the instruction manual, may cause harmful interference to radio communications.

Operation of this equipment in a residential area is likely to cause harmful interference in which case the user will be required to correct the interference at his own expense.

## LIMITED WARRANTY

ADC DSL Systems, Incorporated (“ADC”) warrants that, for a period of sixty (60) months from the date of shipment, the hardware portion of its products will be free of material defects and faulty workmanship under normal use. ADC's obligation, under this warranty, is limited to replacing or repairing, at ADC's option, any such hardware product which is returned during the 60-month warranty period per ADC's instructions and which product is confirmed by ADC not to comply with the foregoing warranty.

ADC warrants that, for a period of 90 days from the date of purchase, the software furnished with its products will operate substantially in accordance with the ADC published specifications and documentation for such software. ADC's entire liability for software that does not comply with the foregoing warranty and is reported to ADC during the 90-day warranty period is, at ADC's option, either (a) return of the price paid or (b) repair or replace of the software. ADC also warrants that, for a period of thirty (30) days from the date of purchase, the media on which software is stored will be free from material defects under normal use. ADC will replace defective media at no charge if it is returned to ADC during the 30-day warranty period along with proof of the date of shipment.

The transportation charges for shipment of returned products to ADC will be prepaid by the Buyer. ADC will pay transportation charges for shipment of replacement products to Buyer, unless no trouble is found (NTF), in which case the Buyer will pay transportation charges.

ADC may use reconditioned parts for such repair or replacement. This warranty **does not** apply to any product which has been repaired, worked upon, or altered by persons not authorized by ADC or in ADC's sole judgment has been subjected to misuse, accident, fire or other casualty, or operation beyond its design range.

---

Repaired products have a 90-day warranty, or until the end of the original warranty period—whichever period is greater.

ADC DISCLAIMS ALL OTHER WARRANTIES, EITHER EXPRESS OR IMPLIED, INCLUDING BUT NOT LIMITED TO IMPLIED WARRANTIES OF MERCHANTABILITY AND FITNESS FOR A PARTICULAR PURPOSE, WITH RESPECT TO ITS PRODUCTS AND ANY ACCOMPANYING WRITTEN MATERIALS. FURTHER, ADC DOES NOT WARRANT THAT SOFTWARE WILL BE FREE FROM BUGS OR THAT ITS USE WILL BE UNINTERRUPTED OR REGARDING THE USE, OR THE RESULTS OF THE USE, OF THE SOFTWARE IN TERMS OF CORRECTNESS, ACCURACY, RELIABILITY OR OTHERWISE.

## MODIFICATIONS

Any changes or modifications made to this device that are not expressly approved by ADC DSL Systems, Inc. voids the user's warranty.

All wiring external to the products should follow the provisions of the current edition of the National Electrical Code.

## SAFETY STANDARDS COMPLIANCE

The ThinMux chassis has been tested and verified to comply with the applicable sections of the following safety standards:

- GR 63-CORE - Network Equipment-Building System (NEBS) Requirements: Physical Protection
- GR 1089-CORE - Electromagnetic Compatibility and Electrical Safety Generic Criteria for Network Telecommunications Equipment
- Bi-national standard, UL-1950/CSA-C22.2 No. 950-95; Safety of Information Technology Equipment

For technical assistance, refer to [“Appendix C - Product Support”](#) on page 19.





**ADC DSL Systems, Inc.**

14402 Franklin Avenue  
Tustin, CA 92780-7013

Tel: 714.832.9922

Fax: 714.832.9924

**Technical Assistance**

Tel: 800.638.0031

Tel: 714.730.3222

Fax: 714.730.2400



DOCUMENT: LTPH-UM-1088-02, ISSUE 2



1204275



## Free Manuals Download Website

<http://myh66.com>

<http://usermanuals.us>

<http://www.somanuals.com>

<http://www.4manuals.cc>

<http://www.manual-lib.com>

<http://www.404manual.com>

<http://www.luxmanual.com>

<http://aubethermostatmanual.com>

Golf course search by state

<http://golfingnear.com>

Email search by domain

<http://emailbydomain.com>

Auto manuals search

<http://auto.somanuals.com>

TV manuals search

<http://tv.somanuals.com>