

Telecommunications

# ICX™-250 User Manual

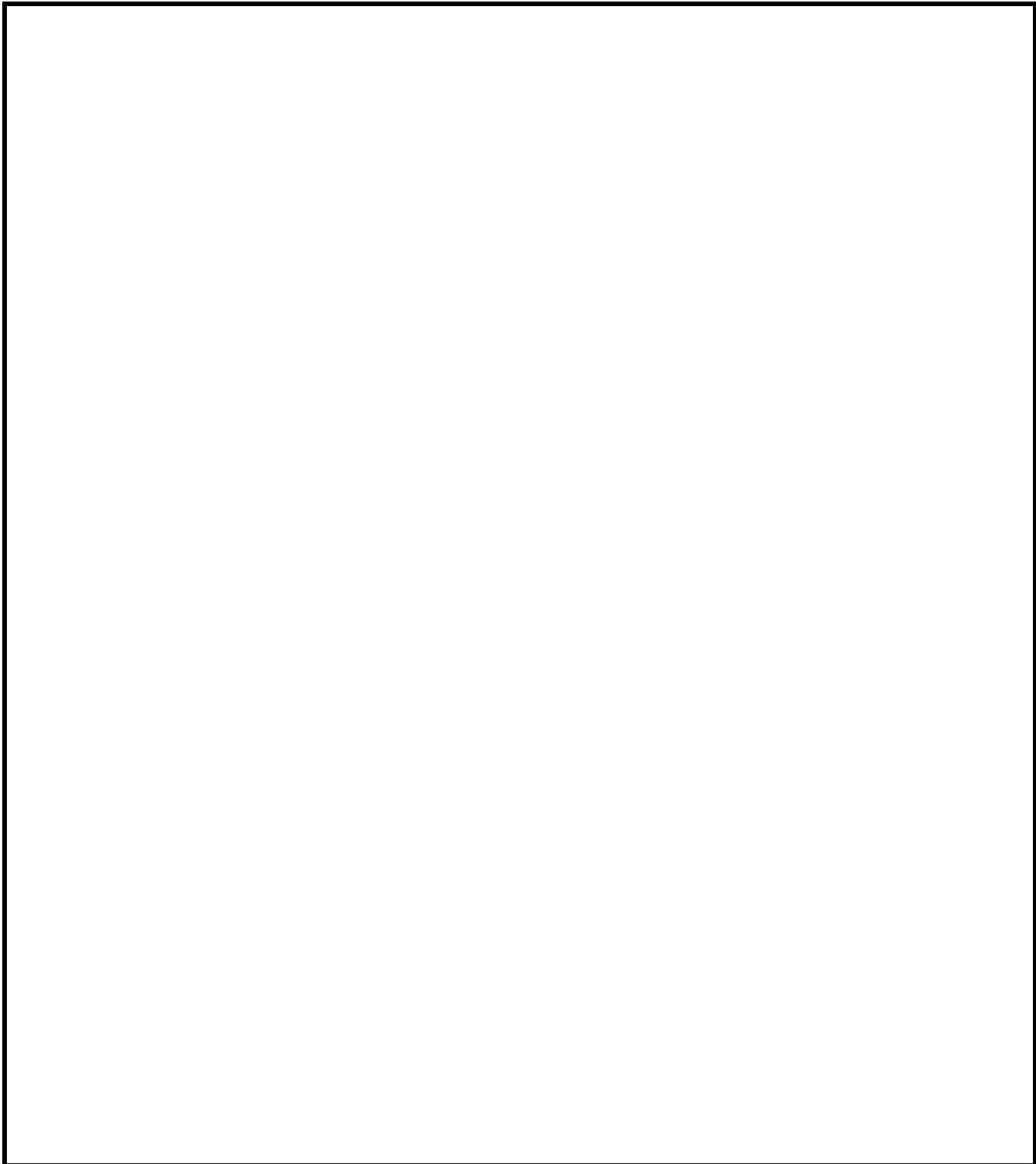

## REVISION HISTORY

EDITION/ISSUE	DATE	REASON FOR CHANGE
Issue 1	09/98	Original.

## LIST OF CHANGES

The technical changes incorporated into this issue are listed below.

PAGE	IDENTIFIER	DESCRIPTION OF CHANGE
		New Manual

## TRADEMARK INFORMATION

ADC and ADC Telecommunications, are registered trademarks of ADC Telecommunications, Inc., ICX is a trademark of ADC Telecommunications, Inc., SLC-96 is a registered trademark of AT&T Technologies, Inc., Bellcore is trademark of Bellcore.

## DISCLAIMER OF LIABILITY

Contents herein are current as of the date of publication. ADC reserves the right to change the contents without prior notice. **In no event shall ADC be liable for any damages resulting from loss of data, loss of use, or loss of profits and ADC further disclaims any and all liability for indirect, incidental, special, consequential or other similar damages. This disclaimer of liability applies to all products, publications and services during and after the warranty period.**

This publication may be verified at any time by contacting ADC's Technical Assistance Center at 1-800-366-3891, extension 3223 (in U.S.A. or Canada) or 612-946-3223 (outside U.S.A. and Canada), or by writing to ADC Telecommunications, Inc., Attn: Technical Assistance Center, Mail Station #77, P.O. Box 1101, Minneapolis, MN 55440-1101, U.S.A.



ADC Telecommunications, Inc.  
 P.O. Box 1101, Minneapolis, Minnesota 55440-1101  
 In U.S.A. and Canada: 1-800-366-3891  
 Outside U.S.A. and Canada: (612) 938-8080  
 Fax: (612) 946-3292

© 1998, ADC Telecommunications, Inc.  
 All Rights Reserved  
 Printed in U.S.A.

## TABLE OF CONTENTS

Content	Page
IMPORTANT SAFETY INSTRUCTIONS .....	vii
INDUSTRY CANADA REQUIREMENTS .....	vii
FCC PART 15 INFORMATION .....	viii
FCC REGULATORY REQUIREMENTS .....	viii
UL APPROVED .....	ix
CSA APPROVED .....	ix
UNPACKING THE ICX-250 .....	2
WHO TO CALL FOR HELP .....	2
PRODUCT OVERVIEW .....	3
FEATURES .....	3
BENEFITS .....	3
TR-08 .....	4
ICX-250 SPECIFICATIONS .....	5
INSTALLING THE ICX-250 .....	8
CHOOSING A SITE FOR THE ICX-250 .....	8
RACK MOUNTING .....	9
LOCATING THE ICX-250 ON A DESKTOP .....	11
WALL MOUNTING .....	12
THE ICX-250 UNIT .....	13
INTERNAL LAYOUT .....	14
INTERNAL DIP SWITCHES .....	18
DIP SWITCH SETTINGS .....	18
SETUP AND CONFIGURE THE ICX-250 .....	20
SWITCHES .....	20
FXS SUPERVISION TABLE .....	25
EXTERNAL DIP SWITCHES .....	31
DIP SWITCH SETTINGS .....	31
CONFIGURATION REFERENCE DATA .....	41
CONNECTOR TYPE .....	44
CONNECTOR PINOUTS .....	45
POWER REQUIREMENTS .....	47
POWER INSTALLATION .....	47
ALARM .....	48
GROUNDING REQUIREMENTS .....	48
CABLING .....	49
TESTING .....	52
SLIDE SWITCH SETTINGS .....	52
T1 LOOPBACK .....	55
DATA PORT 1 AND 2 LOOPBACK .....	59
LED INDICATORS .....	61

---

## TABLE OF CONTENTS

---

Content	Page
WARRANTY/SOFTWARE.....	69
REPAIR/ADVANCE REPLACEMENT POLICY .....	69
REPAIR CHARGES .....	69
REPLACEMENT/SPARE PRODUCTS .....	70
RETURNED MATERIAL .....	70
SYSTEM INTEGRATION SERVICES.....	71
CUSTOMER SUPPORT SERVICES.....	71

## IMPORTANT SAFETY INSTRUCTIONS

Read and follow all warning notices and instructions marked on the product or included in this guide.

1. This product is intended to be used with a three-wire grounding type plug. This is a safety feature. Equipment grounding is vital to ensure safe operation. Do not defeat the purpose of the grounding type plug by modifying the plug or using an adapter.
2. Prior to installation use an outlet tester or a voltmeter to check the AC receptacle for the presence of earth ground. If the receptacle is not properly grounded, the installation must not continue until a qualified electrician has corrected the problem. In addition, a connection for earth or safety grounding is provided on the chassis. It is a #6 threaded stud located next to the AC inlet receptacle.
3. Slots and openings in the ICX-250 are provided for ventilation. To ensure reliable operation of the product and to protect it from overheating, these slots and openings must not be blocked or covered.
4. **DO NOT** allow anything to rest on the power cord and do not locate the product where persons could step or walk on the power cord.
5. **DO NOT** attempt to service this product yourself, as opening or removing covers may expose you to dangerous high voltage points or other risks. Refer all servicing to qualified service personnel.
6. Special cables, which may be required by the regulatory inspection authority for the installation site, are the responsibility of the customer.
7. When installed in the final configuration, the product must comply with the applicable Safety Standards and regulatory requirements of the country in which it is installed. If necessary, consult with the appropriate regulatory agencies and inspection authorities to ensure compliance.
8. A rare phenomenon can create a voltage potential between the earth grounds of two or more buildings. If products installed in separate buildings are interconnected, the voltage potential may cause a hazardous condition. Consult a qualified electrical consultant to determine whether or not this phenomenon exists and, if necessary, implement corrective action prior to interconnecting the product.

## INDUSTRY CANADA REQUIREMENTS

**NOTICE:** The Canadian Industry Canada label identifies certified equipment. This certification means that the equipment meets certain telecommunications network protective, operational and safety requirements. The Department does not guarantee the equipment will operate to the user's satisfaction.

Before installing this equipment, users should ensure that it is permissible to be connected to the facilities of the local telecommunications company. The equipment must also be installed using an acceptable method of connection. In some cases, the company's inside wiring associated with a single line individual service may be extended by means of a certified connector assembly (telephone extension cord). The customer should be aware that compliance with the above conditions may not prevent degradation of service in some situations.

Repairs to the certified equipment should be made by an authorized Canadian maintenance facility designated by the supplier. Any repairs or alterations made by the user to this equipment, or equipment malfunctions, may give the telecommunications company cause to request the user to disconnect the equipment.

Users should ensure for their own protection that the electrical ground connections of the power utility, telephone lines and internal metallic water pipe system, if present, are connected together. This precaution may be particularly important in rural areas.

**CAUTION:** Users should not attempt to make such connections themselves, but should contact the appropriate electric inspection authority, or electrician, as appropriate.

The Ringer Equivalence Number (REN) assigned to each terminal device denotes the percentage of the total load to be connected to a telephone loop which is used by the device, to prevent overloading. The termination on a loop may consist of any combination of devices subject only to the requirement that the total REN of all the devices does not exceed 5. The Ringer Equivalence Number of this unit is Not Applicable.

## FCC PART 15 INFORMATION

This device has been tested and found to comply with FCC Part 15 “Class A” regulations for digital devices. Operation is subject to the following two conditions: (1) This device may not cause harmful interference and (2) This device must accept any interference that may cause undesired operation.

These FCC limits are designed to provide reasonable protection against harmful interference when the equipment is operated in a commercial environment. This equipment generates, uses, and can radiate radio frequency energy, and, if not installed and used in accordance with this User Manual, may cause harmful interference to radio communications. Operation of this equipment in a residential area may cause harmful interference. If this happens, the user would be required to correct the interference at his own expense.

## FCC REGULATORY REQUIREMENTS

### Notice to Users of T1 Service

The following instructions are provided to ensure compliance with the Federal Communications Commission (FCC) Rules, Part 68. FCC Regulatory Number: 1H5USA-32637-DE-N.

1. Before connecting your unit, you must inform the telephone company of the following information:

Port ID	REN/SOC	FIC	USOC
T1 Line	6.0N	04DU9-BN	RJ48C / Dual Bantam Jacks
T1 Line	6.0N	04DU9-DN	RJ48C / Dual Bantam Jacks
T1 Line	6.0N	04DU9-1KN	RJ48C / Dual Bantam Jacks
T1 Line	6.0N	04DU9-1SN	RJ48C / Dual Bantam Jacks

2. If the unit appears to be malfunctioning, it should be disconnected from the telephone lines until you learn if your equipment or the telephone line is the source of the trouble. If your equipment needs repair, it should not be reconnected until it is repaired.
3. If the telephone company finds that this equipment is exceeding tolerable parameters, the telephone company can temporarily disconnect service, although they will attempt to give you advance notice if possible.
4. Under the FCC Rules, no customer is authorized to repair this equipment. This restriction applies regardless of whether the equipment is in or out of warranty.

5. If the telephone company alters their equipment in a manner that will affect use of this device, they must give you advance warning so as to give you the opportunity for uninterrupted service. You will be advised of your right to file a complaint with the FCC.
6. An affidavit must be completed by the installer.
7. In the event of equipment malfunction, all repairs should be performed by our Company or an authorized agent. It is the responsibility of users requiring service to report the need for service to our Company or to one of our authorized agents.

### **UL APPROVED**

The ICX-250 has been designed and tested in accordance with the requirements of UL1950.

### **CSA APPROVED**

The ICX-250 has been designed and tested in accordance with the requirements of CSA C22.2 No. 950.

CHAPTER 1

# Welcome



This chapter introduces you to the features and benefits of ICX-250.

## Contents

Unpacking the ICX-250 .....	2
Product Overview .....	3



## Unpacking the ICX-250

This product is shipped as a complete package. Be very careful when unpacking the carton. Check to see if all items are included in the box by checking against the list shown below (Kit of Parts). In the event any items are missing, contact your distributor for further instructions.

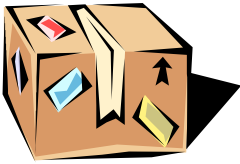

### Opening Up the Carton

Keep all the packaging materials for future use in case the unit has to be returned for maintenance and/or replacement.

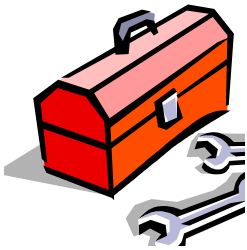

### Kit of Parts

- 2 Mounting brackets
- A 3-Conductor DC power plug
- A 2-Conductor alarm closure plug
- 6 6 x 5/16" self-tapping screws
- 4 12/24 x 1/2" screws
- 1 AC power cord

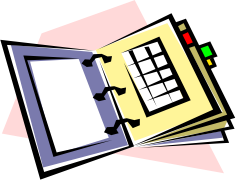

### ICX-250 User Manual (this book)

The *ICX-250 User Manual* contains common tasks: configuration, installation, maintenance, and testing of the unit.



### Hardware and Cabling

The ICX-250 unit comes packaged with an AC power cord to provide power to the unit. It is also shipped with two angle brackets and screws to rack mount your ICX-250 (*this is explained further in Chapter 2 of this manual*).

## Who to Call for Help

Contact ADC Telecommunications if any items are missing or you want to order another ICX-250 unit. For technical support for your ICX-250 unit call the BBG Technical Assistance Center at 1-800-366-3891, extension 3223 (in U.S.A. or Canada) or 612-946-3223 (outside U.S.A. and Canada).

## Product Overview

Bundled Service deployment is a snap thanks to the ICX-250 from ADC Telecommunications. ADC's ICX-250 allows cost-effective and quick deployment of analog voice and data services on a single T1 access trunk.

The ICX-250 sports a sleek, low profile chassis and is configured via DIP switches, eliminating the need for PC based craft interface and specialized training. LEDs are provided for monitoring the status of ICX-250 under normal operation as well as under test conditions. Maintenance and diagnostics are further enhanced via loopbacks and test patterns, all configurable from the DIP switches. Additionally, network loopbacks can be used to test from a remote office.

ICX-250 addresses access needs for sites requiring economical adaptation of FXS analog voice based key systems and PBXs to T1 services. ICX-250 supports TR-08 as well as ESF and D4 framing. Additionally, ICX-250 provides two high speed EIA530A/V.35 ports for insertion of Routers or other data traffic in bundled service arrangements. For sites needing up to 24 analog lines, with or without data requirements, ADC's ICX-250 is an ideal solution.

The ICX-250's primary function is to allow for remote termination of lines from a centrally-located switch. Data ports are also provided on the unit for those applications where high speed data deployment would be required.

The ICX-250 product is complimentary to the leading ICX-500 and Integrated Communications Access server (ICX).

The ICX-250 from ADC Telecommunications - never before have bundled services been so economical and easy to install and maintain.

## Features

- Voice and data channel bank with integral CSU/DSX Interface
- Sleek, low profile, one rack unit (1 RU) chassis
- Choice of 12 or 24 FXS analog voice ports
- Two high speed EIA530A/V.35 data ports
- Extensive diagnostics
- LED status indicators for maintenance
- DIP switch configuration
- TR-08 support

## Benefits

- Minimal Installation Costs - DIP switch based configuration simplifies installation, eliminates need for a computer terminal, and reduces training costs.
- 1 RU design allows easy installation in tight spaces. Rack, wall or desktop mounting options are available.
- Simplified Maintenance - manual test DIP switches, maintenance test and LED status indicators, all simplify maintenance operations.

## TR-08

The TR-TSY-000008 Bellcore™ standard (commonly referred to as TR-08) describes the generic requirements for interfacing between local digital switches and remote digital terminals via the SLC 96™ digital loop carrier system.

TR-08 has three operational modes (ICX-250 supports mode I):

- Modes I & III are non-concentrated and provide unique mapping between channel numbers and DS1 time slots.
- Mode II is concentrated and there are no pre-determined relationships between the channels and timeslots. This allocation of channels to time slots is made possible by the exchange of messages between the Local Digital Switch (LDS) and remote terminal (RT).

Although commonly referred to as the TR-08 standard, the RT channel numbering scheme supported by the ICX-250 unit is described in section 9.9 of the Bellcore publication TR-TSY-000057.

The ICX-250 provides SLC-96 Frame Format and Data Link.

When a T1 port is configured for TR-08 format, the voice channels assigned to this port are identified by “channel number” (according to the TR-TSY-000008 document), which may be different from the T1 time slot number. The ICX-250 supports only Group A. The relation between a channel number and corresponding slot number for TR-08 is shown in the following table.

Channel Numbers	1	2	3	4	5	6	7	8	9	10	11	12	13	14	15	16	17	18	19	20	21	22	23	24
Time Slots	1	3	5	7	9	11	13	15	17	19	21	23	2	4	6	8	10	12	14	16	18	20	22	24

## ICX-250 Specifications

<b>Chassis Specification</b>	Height	1.75 inches (with feet 2 inches)
	Width	17.25 inches
	Depth	12 inches
	Weight	Approximately 10 pounds
<b>Installation</b>		Desktop
		Wall Mount
		Rackmount
<b>Power Supply</b>	AC	120V .6A Max. 60Hz (104 - 140 VAC)
	DC	-48V, -24V, or +24V 1.8A Max. (22.5 - 57 VDC) Integrated AC/DC converter and Ringing Generator
<b>Ring Generator</b>		Nominal 50 VRMS Frequency 20 +/-1 Hz DC component: -30 volts nominal Crest factor cf, where $1.2 = <cf = <1.6$ Ringing Capability: 40 Vrms across 1 REN at the end of a 400 ohms loop.
<b>Environment</b>	Operating Temperature	0 <sup>0</sup> C to 40 <sup>0</sup> C
	Storage Temperature	-40 <sup>0</sup> C to 66 <sup>0</sup> C
	Relative Humidity	5 to 85% Humidity, Non-Condensing
<b>Regulatory Compliance</b>		FCC Part 15 Class A
		UL 1950 and CSA C22.2 950
		FCC Part 68 and Industry Canada CS-03
<b>FCC Regulatory #</b>		1H5USA-32637-DE-N
<b>Product Numbers</b>	240212	12 FXS ports, 2 EIA530A/V.35 data ports
	240224	24 FXS ports, 2 EIA530A/V.35 data ports
<b>T1 Interface</b>	Physical	One RJ48
	Frame Format	D4, ESF, TR-08
	Line Code	AMI, B8ZS
	CSU Line Build Out (LBO)	0 dB, -7.5 dB, -15.0 dB
	DSX Line Length	0.6 dB at 0-266 ft., 1.8 dB at 266 - 533 ft., 3.0 dB at 533 - 655 ft.
	Clocking	Internal Stratum 4, Line
	FDL	Per ANSI T1.403 and AT&T TR62411
<b>FXS Interface</b>	Physical	One 50-pin Female Amphenol
	FXS Supervision Mode	FXS, FXS-DN, FXS-DN-Wink, TR-08
	FXS Signaling	Loop Start, Ground Start, Loop Start w/ forward Disconnect, Ground Start Immediate, Ground Start Automatic, Universal Voice Grade, Universal Voice Grade Automatic, Single-Party
	TLP	-3 dB/-9 dB on Rx, + 3 dB/+9 dB on Tx
	Impedance	600 Ohm
	Ringing Voltage	50 Vrms
<b>Data Interface</b>	Physical	On hook transmission for Caller ID support
	Data Rate	Two (2) EIA530A/V.35 ports (DB25) Nx56K, Nx64K (N = 1 to 24)
<b>Diagnostics</b>		Extensive power-up self test
		LED Indicators
		QRSS Test Pattern on T1
		2047 Test Pattern on Data ports
		Loopbacks for FXS, T1 and Data ports
		CSU Loopback detection
		Performance statistics over FDL
		Bantam jacks for in-session T1 monitoring and line testing
<b>DIP Switch Settings</b>		FXS, T1, Data port Loopbacks, CSU Loopback Detection, Clocking, T1 Frame Format, T1 Line Code, T1 Line Build Out, FXS TLP, FXS Supervision, FXS Signaling, Trunk Conditioning, Test Patterns, Data rate.

## CHAPTER 2

# System Basics

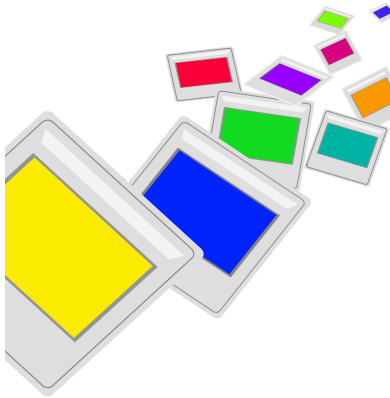

This chapter gives you quick, simple instructions to get you up and running. You will also learn how to install and mount the ICX-250 unit.

## Contents

Installing the ICX-250 . . . . .	8
The ICX-250 Unit . . . . .	13

## Installing the ICX-250

The ICX-250 unit can be installed in a rack, on a desktop or attached to a wall using appropriate wall anchors and brackets. It is necessary to read the information that follows to ensure proper reliability of unit.

### Choosing a Site for the ICX-250

When choosing a site for your ICX-250 unit make sure that the instructions on installing the unit are followed. Provide adequate ventilation and ample room for cable routing.

#### Temperature Specifications

Shipping and storage  $-40^{\circ}\text{C}$  to  $+66^{\circ}\text{C}$

Operating temperature range  $0^{\circ}\text{C}$  to  $+40^{\circ}\text{C}$

Relative Humidity 5 to 85% Non-Condensing



**Note:** The ICX-250 is equipped with a fan to ensure proper cooling and reliability. In the event that the installation environment temperature exceeds the standards above, it is recommended that adjustments be made. Improper operation outside of these temperatures may result in performance degradation.

#### Precautionary Procedures

There are several precautions to take before installing and/or servicing the ICX-250 unit.



#### **CAUTION**

*Never install telephone wiring during a lightning storm.*

*Never install telephone jacks in wet locations unless the jack is specifically designed for this purpose **ONLY**.*

*Never touch uninsulated telephone wires or terminals unless the telephone line has been disconnected at the network interface.*

*Use **CAUTION** when installing or modifying telephone lines.*

*Never attempt to service this product unless you are an authorized service technician. Doing so can result in injury or damage to the unit and void all warranties.*

## Rack Mounting

The chassis comes with brackets for rack mounting. The installation site for rack mounting should provide proper room for ventilation and cable routing. Provide at least 2 inches of clearance between each ICX-250 unit to allow for removal of the top if necessary for resetting of switches.



**Note:** Check all grounding instructions when installing the ICX-250 unit in a rack. Proper grounding is mandatory at all times.

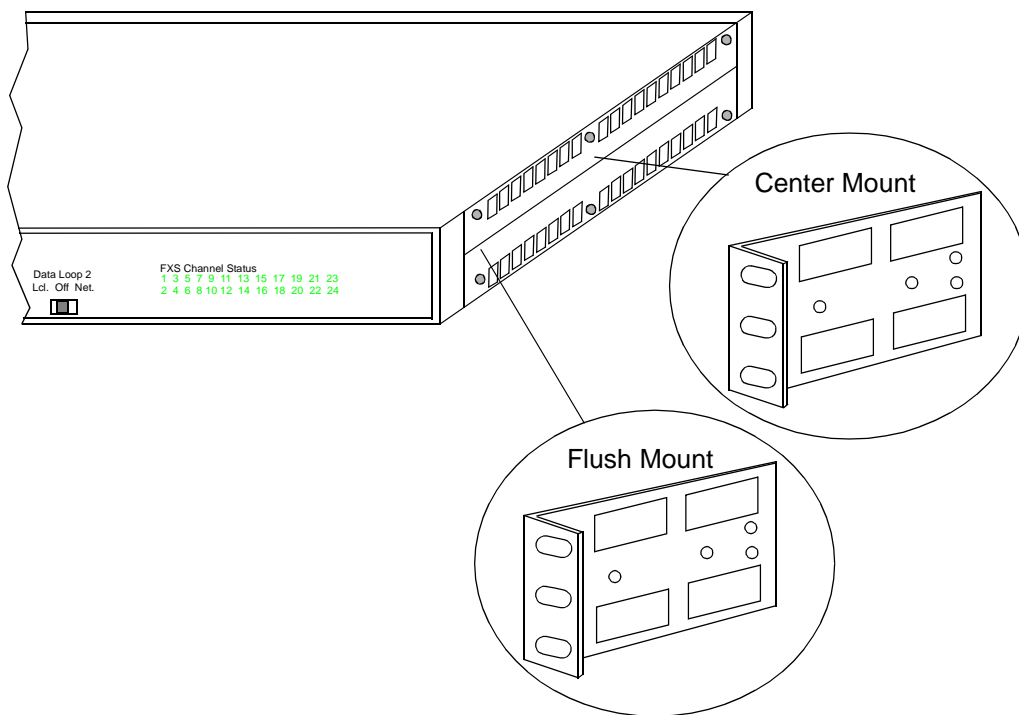

The following figure depicts a 19" rack mount configuration.

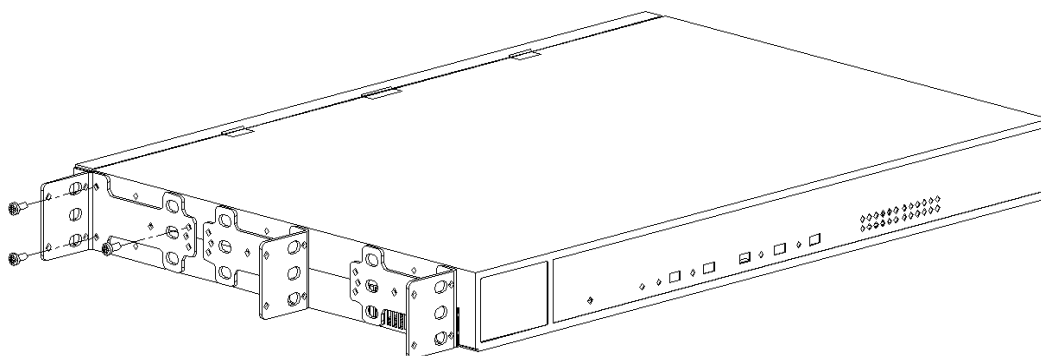

The following figure depicts a 23" rack mount configuration.

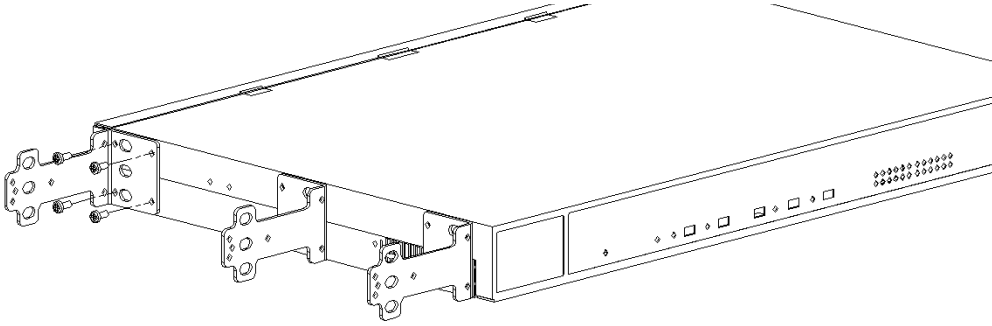

**!!ATTENTION!!** Set all options prior to installing mounting brackets, top cover cannot be removed once brackets are in place.



## Locating the ICX-250 on a Desktop

Each unit can be easily set on top of a desk or table. A stable environment is necessary for peak performance of each unit.

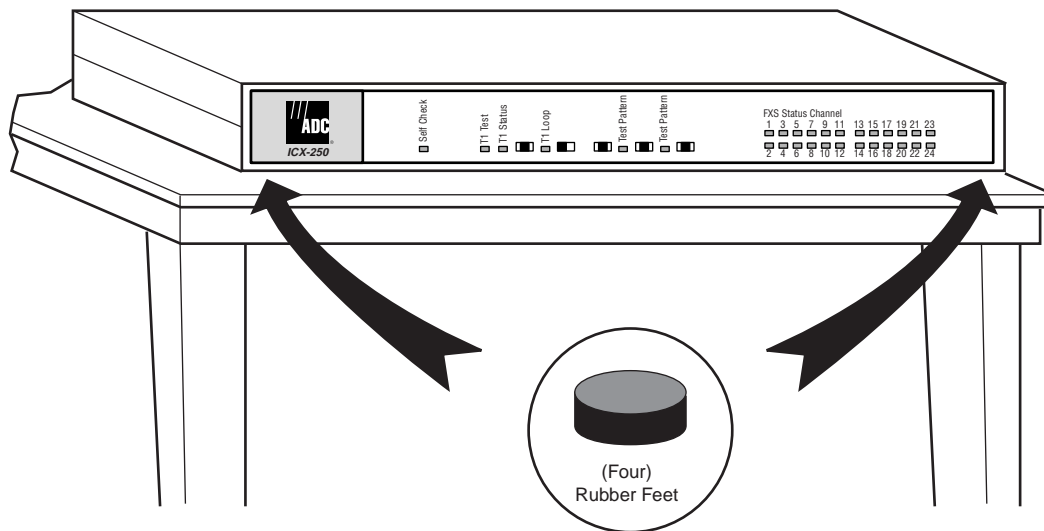

Rubber feet are necessary for proper ventilation and air flow of the unit when mounted on a flat surface. Removing them may damage the unit.

### DO NOT Remove Rubber Feet

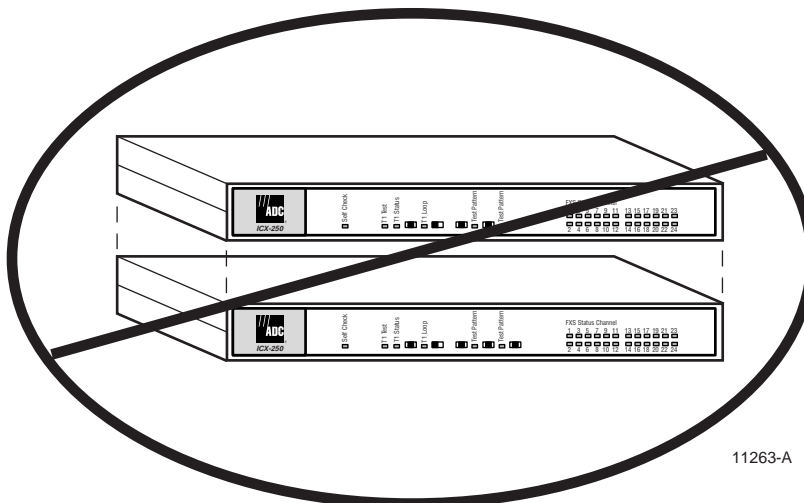

11263-A

## Wall Mounting

Prior to wall mounting check to see if the environment is stable and free from any extreme temperatures, humidity or vibrations of any sort. The unit should be mounted with the fan to the top with at least 2 inches of clear space on the sides, above, and below for adequate air flow. Allow at least 6 inches for cable clearance and access to switches.

When attaching unit(s) to a wall make sure that appropriate fasteners such as masonry anchors, heavy duty wood screws or expansion bolts are used for heavy objects.



**!!ATTENTION!!** Set all options prior to installing mounting brackets, top cover cannot be removed once brackets are in place.



**Note:** Additional support hardware may be necessary (not included with unit) to secure the unit properly to the wall. If the surface is not solid enough to hold the unit and attached cabling, it is recommended that a small piece of 3/4" plywood be fastened to the wall before attaching the unit. This will help ensure a more stable environment.

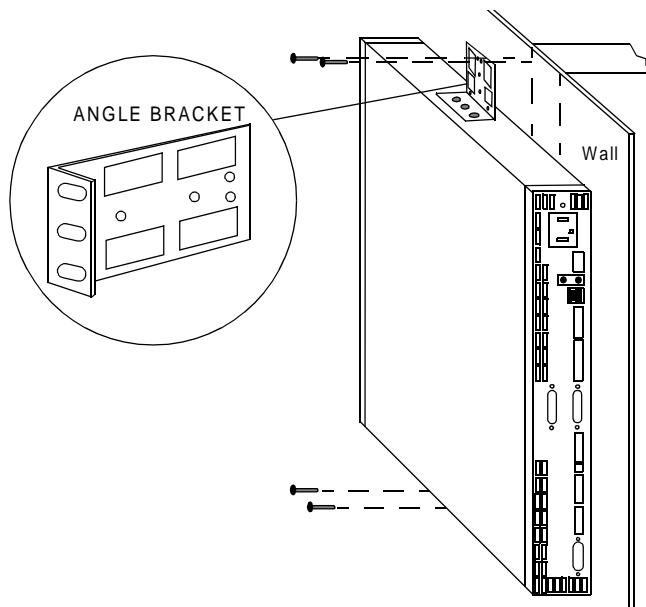

# The ICX-250 Unit

The ICX-250 comes equipped with either 12 FXS (model 240212) or 24 FXS (model 240224) analog voice ports depending on which model you purchase. Each unit is designed to allow easy accessibility to switches and electrical connectors. The diagrams below illustrate the front and rear layout of the unit. The diagram on the next page illustrates the internal layout of the unit.



**Note:** The 12 FXS or 24 FXS models are not field upgradeable.

## ICX-250 - Front Panel

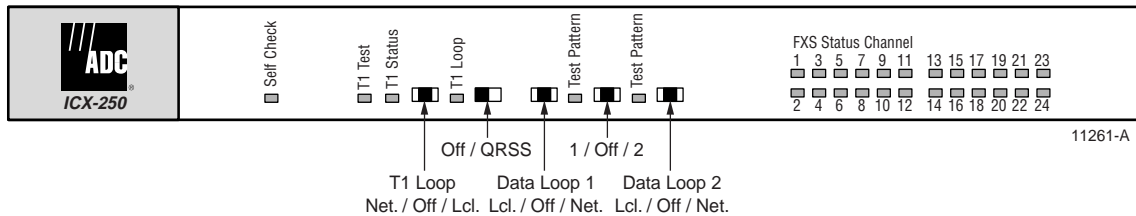

## ICX-250 - Rear Panel

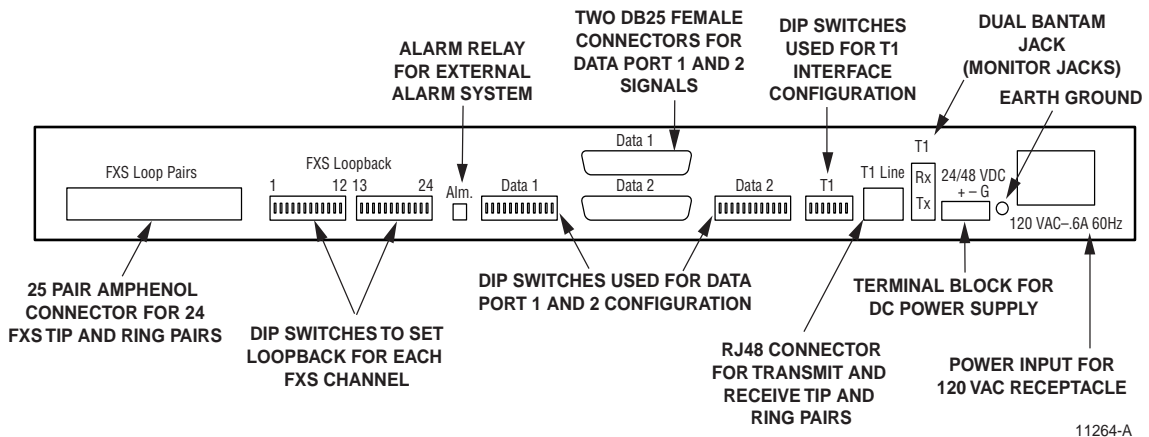

## Internal Layout

### 12 FXS Analog Voice Ports

The illustration below shows the internal layout of the 12 FXS analog voice port unit.

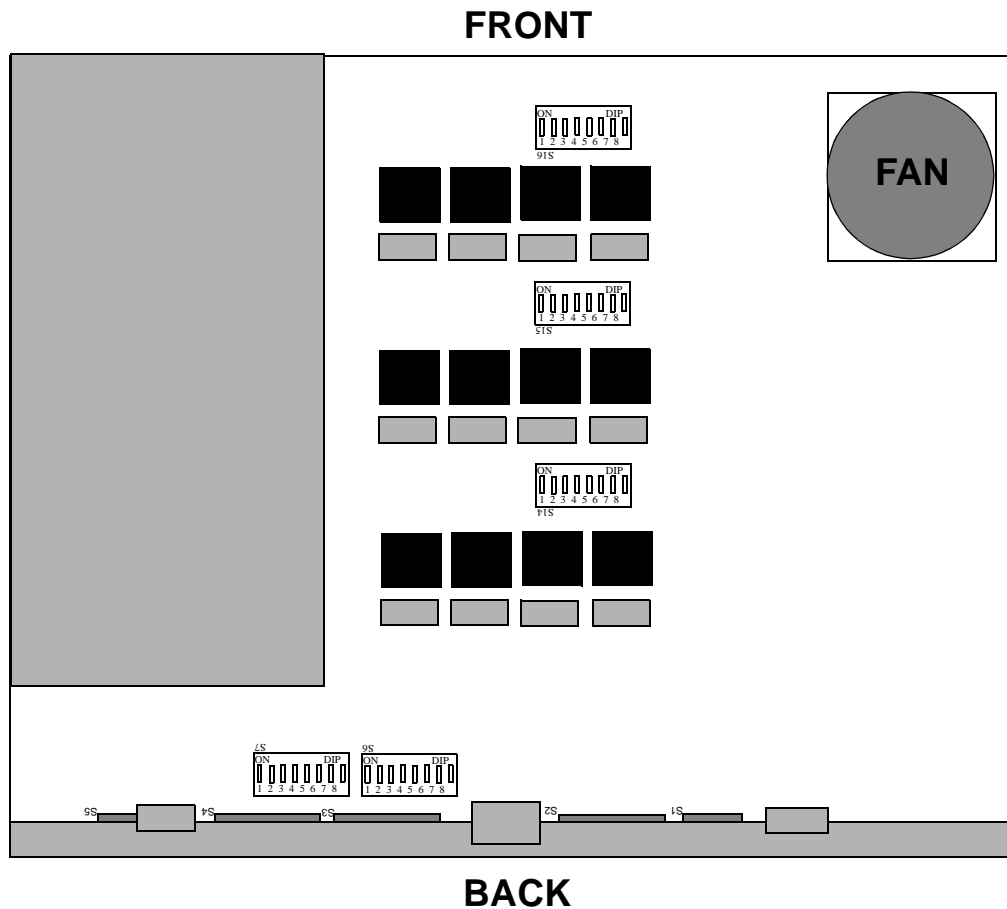

24 FXS Analog Ports

The illustration below shows the internal layout of the 24 FXS analog voice port unit.

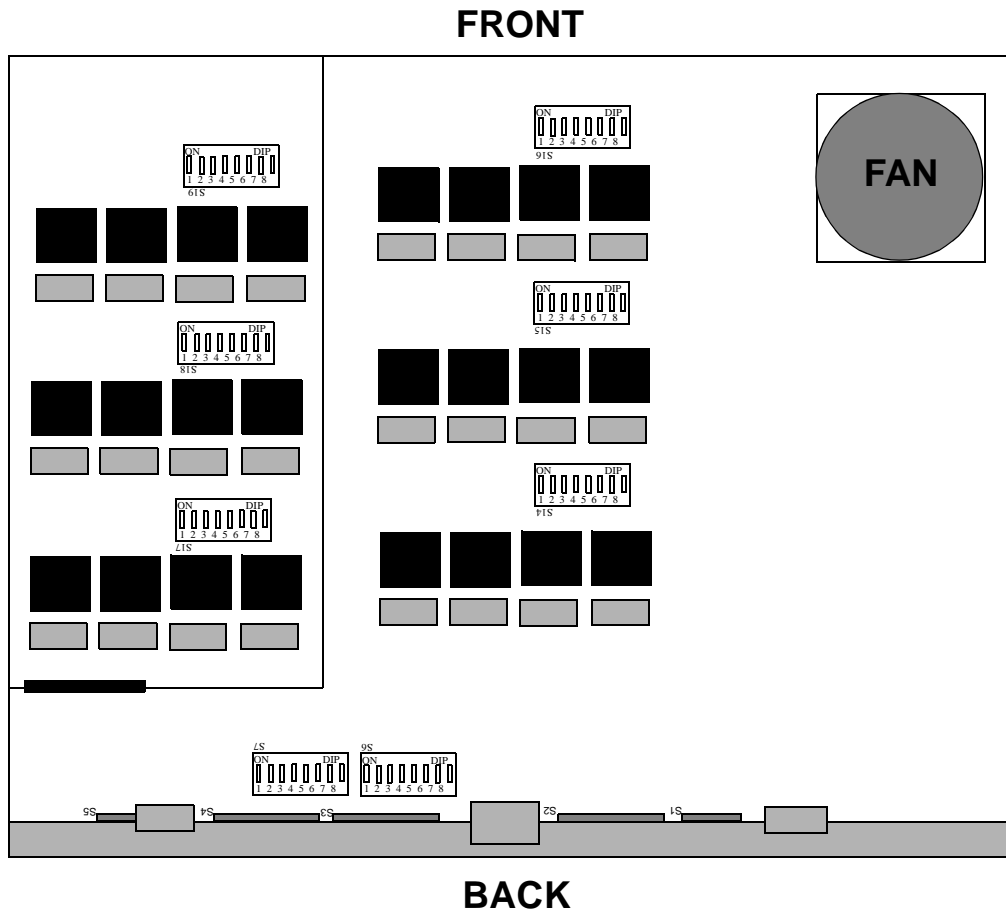

## CHAPTER 3

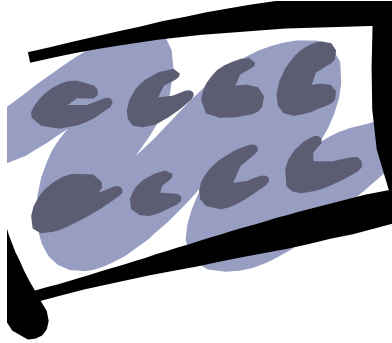

# Configuring the ICX-250

Inside this chapter you will learn how to configure the ICX-250 unit using internal and external switch settings.

## Contents

Internal DIP Switches . . . . .	18
Setup and Configure the ICX-250 . . . . .	20
Switches . . . . .	20
External DIP Switches . . . . .	31
Configuration Reference Data . . . . .	41

## Internal DIP Switches

The ICX-250 comes equipped with either 12 FXS or 24 FXS analog voice ports depending on which model you purchase. For illustration purposes the 24 FXS port model is shown. There are a total of eight internal DIP switches (*five on the main circuit board, and three on the auxiliary board*).



**Note:** The individual switches on each switch assembly operate independently of one another.

## DIP Switch Settings

Locate the DIP switch internally that describes the function you wish to effect. The top cover of the unit displays the configurable options. Use the tip of a small object to change the switch settings. The switches will glide easily into place.



### **CAUTION**

Access to the internal switches is accomplished by opening the case. Use care when opening the case to avoid damaging the internal components.

### **TIP**



Switch setting changes will take effect immediately.

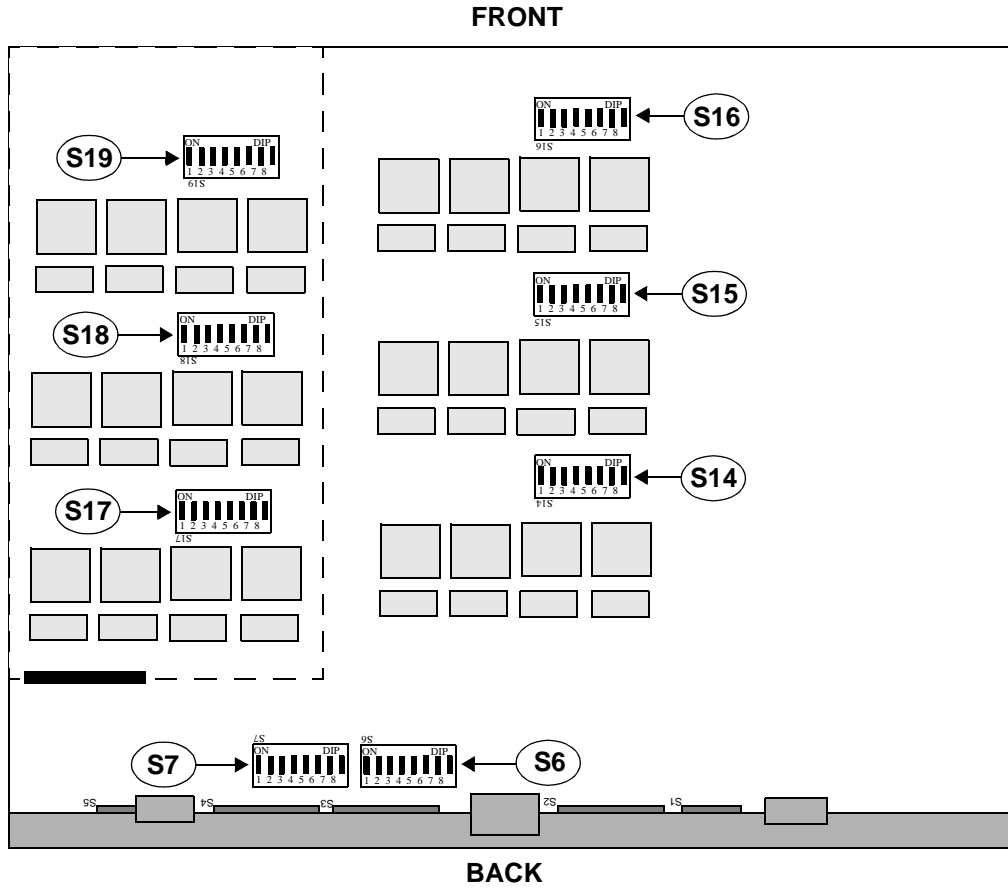



## Setup and Configure the ICX-250

To configure the ICX-250 for your operating environment, switch settings are easily accessible. There are internal and external control dip and slide switches.

### Switches

The ICX-250 unit is equipped with internal and external DIP switches.

The following table describes the switches that are used to configure the ICX-250 for operation. Refer to the silkscreen on the cover of the unit for location of switches. Parenthetical references indicate the page number that detail the operation.

The bold highlighted selection under "Options" is the Factory Setting.				
Function	Switch	Switch Location	Option	Description
<b>FXS PORTS:</b>				
FXS Supervision <i>Mode</i> (for entire bank of 12 lines) (see page 23)	S6, S7 positions 1 and 2	Internal	<b>FXS</b> FXS-DN FXS-DN-Wink TR-08	<b>FXS:</b> Foreign Exchange Subscriber. <b>FXS-DN:</b> Foreign Exchange Subscriber-Defined Network. <b>FXS-DN-WINK:</b> Foreign Exchange Subscriber-Defined. Network-Wink Start Operation. <b>TR-08:</b> Frame Format Signaling and Data Link as outlined in TR-TSY-000008 Mode 1 for circuits using AT&T Subscriber Loop Carriers (SLC-96) facilities.
FXS Supervision <i>Type</i> (for entire bank of 12 lines) (see page 24)	S6, S7 positions 3, 4 and 5	Internal	<b>Loop Start</b> Single Party Ground Start Ground Start Automatic Ground Start Immediate Universal Voice Grade Universal Voice Grade Automatic Loop Start-Forward Disconnect	<b>Loop Start:</b> Used with traditional telephone stations and simple PBX trunks. <b>Single Party:</b> SLC-96 Single Party Service. <b>Ground Start:</b> Used with two-way PBX trunks. <b>Ground Start Automatic:</b> Used with equipment requiring fast-response time to the central office (CO). <b>Ground Start Immediate:</b> Used with equipment requiring fast-response time to the station or PBX. <b>Universal Voice Grade:</b> Toll quality voice for SLC-96. <b>Universal Voice Grade Automatic:</b> Used with some non-Bell switches. Loop Start-Forward Disconnect: Provides disconnect when FXS is connected to voice messaging system.

The bold highlighted selection under "Options" is the Factory Setting.				
Function	Switch	Switch Location	Option	Description
FXS Ports Transmit for 12 port model (see page 26)	S14, S15, S16 positions 2, 4, 6 and 8	Internal	<b>3 dB</b> 9 dB	<b>3 dB</b> : Transmit path attenuated by 3 dB (+/- .5). <b>9 dB</b> : Transmit path attenuated by 9 dB (+/- .5).
FXS Ports Receive for 12 port model (see page 26)	S14, S15, S16 positions 1, 3, 5 and 7	Internal	<b>3 dB</b> 9 dB	<b>3 dB</b> : Receive path attenuated by 3 dB (+/- .5). <b>9 dB</b> : Receive path attenuated by 9 dB (+/- .5).
FXS Ports Transmit for 24 port model (see page 26)	S17, S18, S19 positions 2, 4, 6 and 8	Internal	<b>3 dB</b> 9 dB	<b>3 dB</b> : Transmit path attenuated by 3 dB (+/- .5). <b>9 dB</b> : Transmit path attenuated by 9 dB (+/- .5).
FXS Ports Receive for 24 port model (see page 26)	S17, S18, S19 positions 1, 3, 5 and 7	Internal	<b>3 dB</b> 9 dB	<b>3 dB</b> : Receive path attenuated by 3 dB (+/- .5). <b>9 dB</b> : Receive path attenuated by 9 dB (+/- .5).
Trunk Conditioning (per group of 12 lines) (see page 28)	S6, S7 position 6	Internal	<b>Idle</b> Idle Imm./Busy	<b>Idle</b> : In the event of an alarm condition in the T1 connection to the network, the FXS Ports will be put into the idle state immediately and remain in this condition until the T1 has been restored. <b>Idle Immediate/Busy</b> : In the event of an alarm condition in the T1 connection between the ICX-250 and the network, the FXS Ports will be put into the Idle state immediately for 3 seconds and then put in the Busy state and remain in this condition until the T1 has been restored.
FXS Ringback Tone (see page 29)	S6-S7 position 7	Internal	<b>On</b> <b>Off</b>	<b>On</b> : Ringback tones will be sent on the corresponding DS0's for the duration of ringing on the line. <b>Off</b> : Ringback provided by PBX or Switch.
FXS Timeslot Assignment (see page 30)	S7 Only position 8	Internal	<b>Off</b> Swap	<b>Off</b> : FXS Ports 1-12 are mapped onto T1 timeslots 1-12 and FXS Ports 13-24 are mapped onto T1 timeslots 13-24. <b>Swap</b> : FXS Ports 1-12 are mapped onto T1 timeslots 13-24 and FXS Ports 13-24 are mapped onto T1 timeslots 1-12. <b>Depending on the services provided by your carrier for voice and data, you may need to reassign the FXS timeslots of the 12 FXS port model. Timeslots 13 to 24 will be assigned in order to allocate data to the lower timeslots.</b>
FXS Ports Loopback Operation and/or Channel Unassigned (per line) (see page 39)	S4-S5 S5 1-12 = 1-12 S4 1-12 = 13-24	Back	<b>On</b> <b>Off</b>	<b>On</b> : Breaks the connections to and from the FXS and loops the receive data back onto the transmit path towards the T1. In the case of unassigned channels, provides an idle termination.

The bold highlighted selection under "Options" is the Factory Setting.				
Function	Switch	Switch Location	Option	Description
<b>T1 INTERFACE:</b>				
T1 Interface Frame Format (see page 32)	S1 positions 1 and 2	Back	D4 (SF) <b>ESF</b> TR-08	Selects the T1 frame format and data link format to be either D4 (SF), ESF, or TR-08. (No data link with D4).
T1 Interface Line Code (see page 32)	S1 position 3	Back	AMI <b>B8ZS</b>	Selects the line code on the T1 interface.
T1 Interface T1 Clock (see page 33)	S1 position 4	Back	<b>Line</b> Internal	<b>Line:</b> Clock for the T1 interface will be recovered from the line (receive signal). <b>Internal:</b> Clock for the T1 interface will be taken from an on-board 1.544 MHz clock meeting the Stratum 4 requirements.
T1 Interface CSU Loop Code Recognition (see page 34)	S1 position 5	Back	Accept <b>Ignore</b>	<b>Accept:</b> ICX-250 will respond to network generated loop requests that are received over the FDL. <b>Ignore:</b> ICX-250 will ignore network generated loop requests.
T1 Interface Line Build Out (see page 34)	S1 positions 6 and 7	Back	<b>0 dB</b> -7.5 dB -15.0 dB	Selects one of three line build out options for short (-15.0 dB), medium (-7.5 dB) and long (0 dB) loops.
<b>DATA PORTS:</b>				
Data Ports 1 and 2 Number of Timeslots (see page 35)	S2 - dataport 2 positions 1, 2, 3, 4 and 5 S3 - dataport 1 positions 1, 2, 3, 4 and 5	Back	<b>0</b> 1, 2, 3, ....24	Selects the number of timeslots that data from Data Port 1 and/or 2 will be mapped onto.
Data Ports 1 and 2 Starting Timeslot (see page 37)	S2 - dataport 2 positions 6, 7, 8, 9 and 10 S3 - dataport 1 positions 6, 7, 8, 9 and 10	Back	<b>0</b> 1, 2, 3, ....24	Selects first T1 timeslot that data from Data Port 1 and/or 2 will be mapped.
Data Ports 1 and 2 Interface Type (see page 38)	S2, S3 position 11	Back	EIA530A <b>V.35</b>	<b>EIA530A:</b> Ports 1 and/or 2 use the EIA530A standard. <b>V.35:</b> Ports 1 and/or 2 use the V.35 standard.
Data Ports 1 and 2 Data Rate (see page 39)	S2, S3 position 12	Back	64 Kbps <b>56 Kbps</b>	<b>64Kbps:</b> Ports 1 or 2 receive and transmit data at a multiple of 64 Kbps. <b>56Kbps:</b> Ports 1 or 2 receive and transmit data at a multiple of 56 Kbps.



**Note:** The function and speed of Data Ports 1 and 2 are independent of each other. This allows one to operate as EIA530A while the other operates as a V.35 interface. The speeds can also be set as 56K on one port and 64K on the other.

### FXS Supervision - Mode (DIP switches - internal)

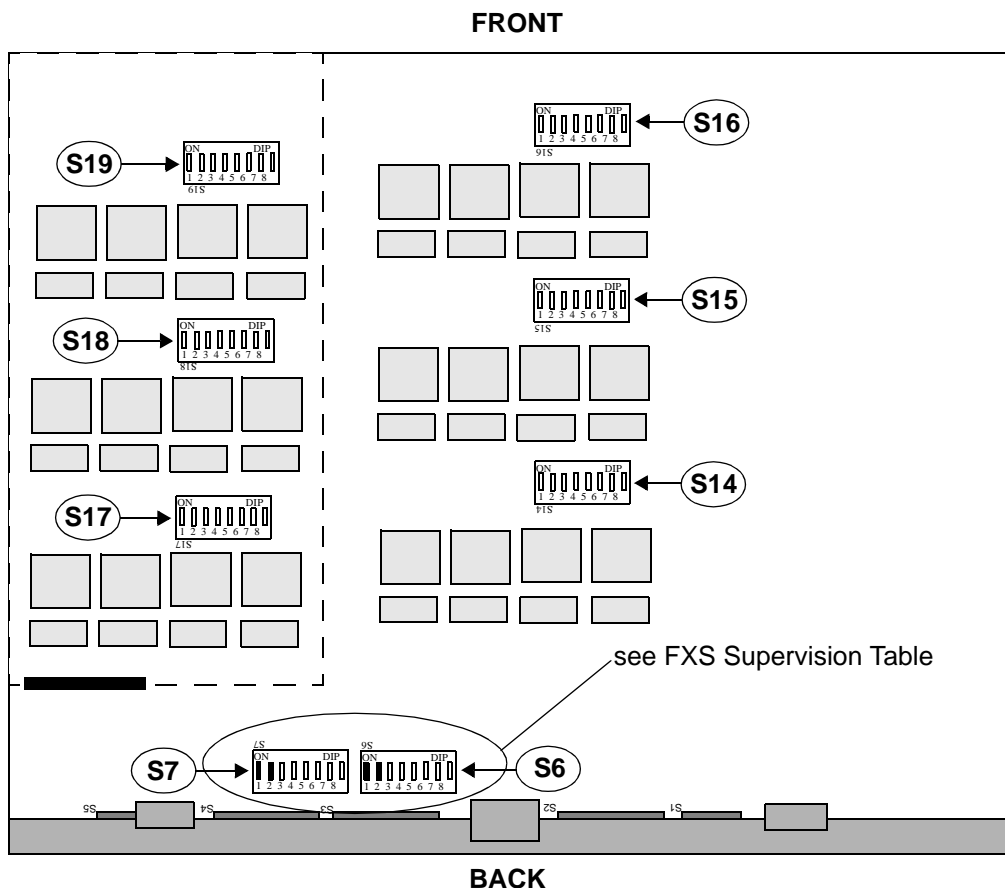

**Description:** S6 and S7 positions 1 and 2 select the FXS Mode. Options are: FXS, FXS-DN, FXS-DN-WINK, and TR-08.

**Factory Setting:** FXS

**FXS:** Foreign Exchange Subscriber.

**FXS-DN:** Foreign Exchange Subscriber-Defined Network.

**FXS-DN-WINK:** Foreign Exchange Subscriber-Defined Network-Wink Start Operation.

**TR-08:** Signaling as outlined in TR-TSY-000008 Mode 1 for circuits using AT&T Subscriber Loop Carriers (SLC-96) facilities.

### FXS Supervision - Type (DIP switches - internal)

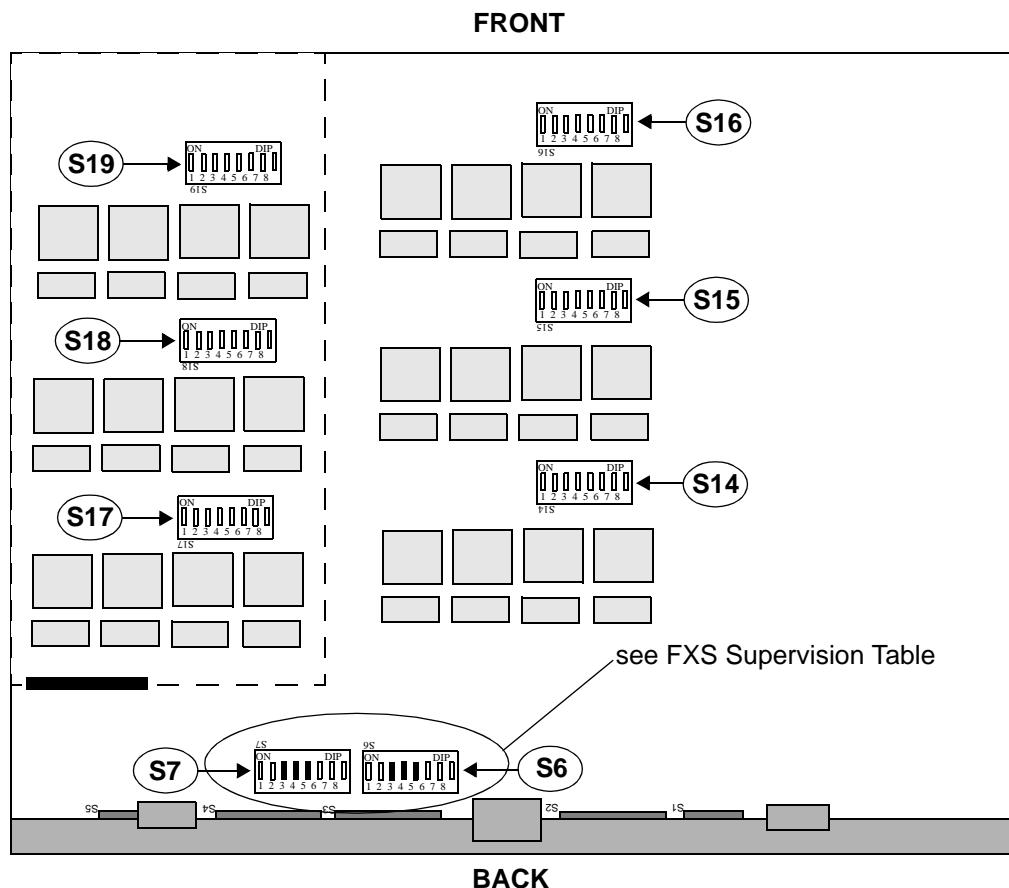

**Description:** S6 and S7 positions 3, 4 and 5 determine the FXS type. Options are: Loop Start, Single Party, Ground Start, Ground Start Automatic, Ground Start Immediate, Universal Voice Grade, Universal Voice Grade Automatic and Loop Start Forward Disconnect.

**Factory Setting:** LOOP START

**Loop Start:** Tip and Ring closure used with traditional telephone stations and simple PBX lines.

**Loop Start-Forward Disconnect:** Provides disconnect when FXS is connected to voice messaging system.

**Ground Start:** Used with two-way PBX lines.

**Ground Start Automatic:** Used with equipment requiring fast-response time to the central office (CO).

**Ground Start Immediate:** Used with equipment requiring fast-response time to the station or PBX.

**Single Party:** Single Part Service for SLC-96.

**Universal Voice Grade:** Toll quality voice for SLC-96.

**Universal Voice Grade Automatic:** Used with some non-bell switches.



**!!ATTENTION!!** Changing the Supervision type switches will result in all FXS calls on the affected 12 FXS line group to be reset to the idle state each time a DIP switch setting is changed. This means any active calls in that FXS line group will be dropped.

## FXS Supervision Table

(Mode)	1, 2	3, 4, 5 (Type)				
		000	001	100	101	110
FXS	00	LS	LS-fd	GS	GSa	GSi
FXS-DN	01	LS	LS-fd	GS	GSa	GSi
FXS-DN-WINK	10	LS	LS-fd	GS	GSa	GSi
TR-08	11	SP	---	UVG	UVGa	---

Legend: (e.g. S1 position 5 = 01001 means Mode = FXS-DN / Type = LS-fd)

LS = Loop Start

LS-fd = Loop Start-Forward Disconnect

GS = Ground Start

GSa = Ground Start Automatic

GSi = Ground Start Immediate

SP = Single Party

UVG = Universal Voice Grade

UVGa = Universal Voice Grade Automatic

FXS Ports (per line) - Transmit / Receive (DIP switch - internal)

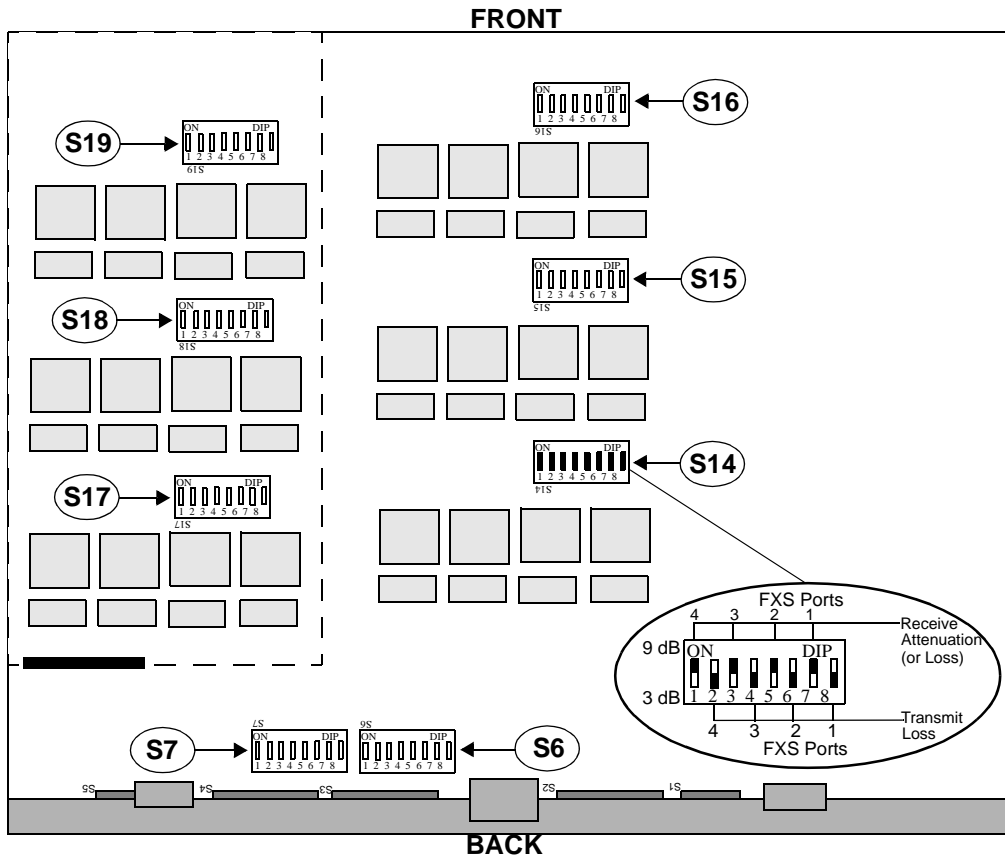

**Description:** These are eight position DIP switches used to set Transmit and Receive FXS attenuation (TLP Setting).

**Factory Setting:** 3 dB (OFF) The DIP switch layout shown above is an example using 3 dB of attenuation on the Transmit side (positions 2,4,6,8 off) and 9 dB on the Receive side (positions 1,3,5,7 on). If it is necessary to change the Transmit setting to attenuate the line by 9 dB, the related switch position(s) would be set to the “On” setting. Receive side settings would be changed from 9 dB to 3 dB by moving the related switch position to “Off.” See the chart on page 27 for more detail on the switch settings. **3dB:** Transmit / Receive path will be attenuated by 3 dB (+/- 0.5). **9dB:** Transmit / Receive path will be attenuated by 9 dB (+/-0.5).



**!!ATTENTION!!** The above FXS Port settings are repeated for each of the 12 or 24 lines.

### Switch Settings for FXS Port Transmit and Receive Attenuation

The table below represents the FXS port transmit and receive attenuation (loss) control settings.

FXS Port	Switch Number	3 dB Attenuation		9 dB Attenuation	
		Transmit	Receive	Transmit	Receive
1	S14	8 = OFF	7 = OFF	8 = ON	7 = ON
2		6 = OFF	5 = OFF	6 = ON	5 = ON
3		4 = OFF	3 = OFF	4 = ON	3 = ON
4		2 = OFF	1 = OFF	2 = ON	1 = ON
5	S15	8 = OFF	7 = OFF	8 = ON	7 = ON
6		6 = OFF	5 = OFF	6 = ON	5 = ON
7		4 = OFF	3 = OFF	4 = ON	3 = ON
8		2 = OFF	1 = OFF	2 = ON	1 = ON
9	S16	8 = OFF	7 = OFF	8 = ON	7 = ON
10		6 = OFF	5 = OFF	6 = ON	5 = ON
11		4 = OFF	3 = OFF	4 = ON	3 = ON
12		2 = OFF	1 = OFF	2 = ON	1 = ON
13	S17	8 = OFF	7 = OFF	8 = ON	7 = ON
14		6 = OFF	5 = OFF	6 = ON	5 = ON
15		4 = OFF	3 = OFF	4 = ON	3 = ON
16		2 = OFF	1 = OFF	2 = ON	1 = ON
17	S18	8 = OFF	7 = OFF	8 = ON	7 = ON
18		6 = OFF	5 = OFF	6 = ON	5 = ON
19		4 = OFF	3 = OFF	4 = ON	3 = ON
20		2 = OFF	1 = OFF	2 = ON	1 = ON
21	S19	8 = OFF	7 = OFF	8 = ON	7 = ON
22		6 = OFF	5 = OFF	6 = ON	5 = ON
23		4 = OFF	3 = OFF	4 = ON	3 = ON
24		2 = OFF	1 = OFF	2 = ON	1 = ON



### FXS Ports - Trunk Conditioning (*DIP switches - internal*)

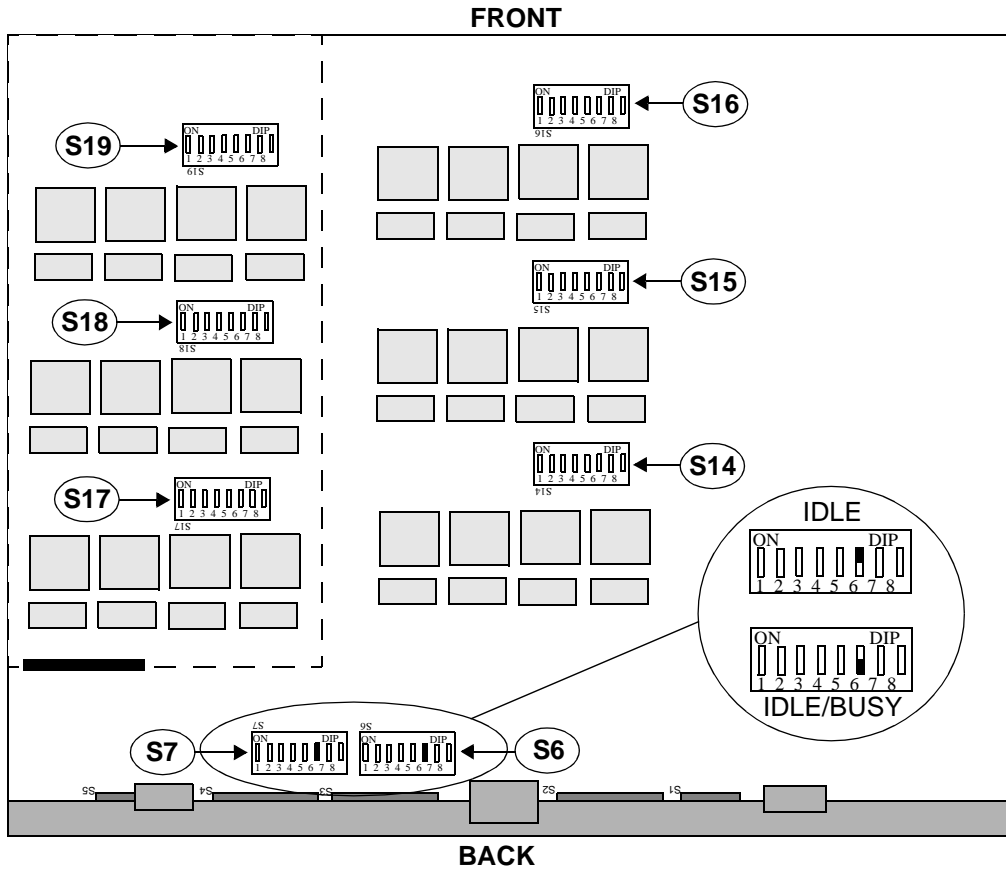

**Description:** S6 position 6 and S7 position 6 selects the trunk conditioning state.

**Factory Setting:** IDLE

**Idle:** In the event of an alarm condition in the T1 connection to the network, the FXS Ports will be put into the idle state immediately and remain in this condition until the T1 has been restored.

**Idle Immediate/Busy Delay:** In the event of an alarm condition in the T1 connection between the ICX-250 and the network, the FXS Ports will be put into the Idle state immediately for 3 seconds and then put into the Busy state and remain in this condition until the T1 has been restored.

The DIP switch settings shown in the illustration above are for Switch S6 and S7.

### FXS Ports - FXS Ringback Tone (DIP switches - internal)

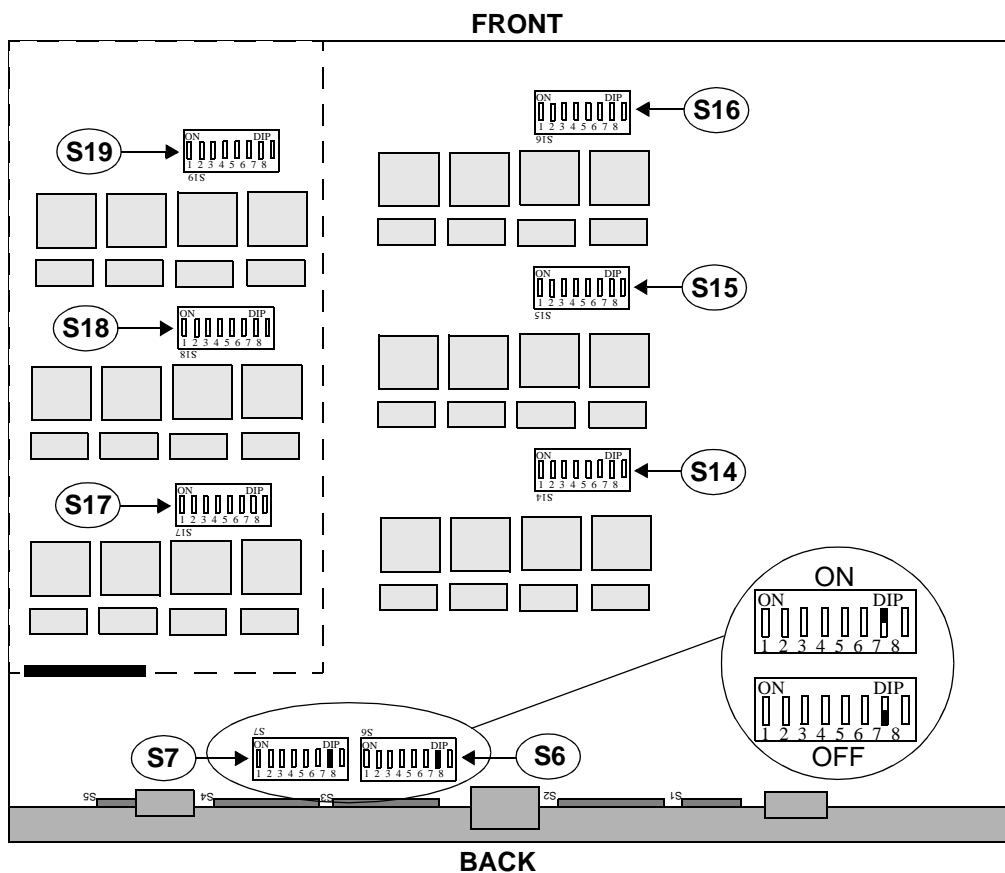

**Description:** S6 position 7 and S7 position 7 provides ringback tone when it is not available from the PBX or Switch.

**Factory Setting:** OFF

**ON:** Ringback tones will be sent to the applicable FXS channels by the unit if not provided by the Switch or PBX for the duration of ringing on the line.

**OFF:** Ringback provided by PBX or Switch.

The DIP switch settings shown in the illustration above are for Switches S6 and S7.

### FXS Ports - FXS Time Slot Assignment (DIP switch - internal)

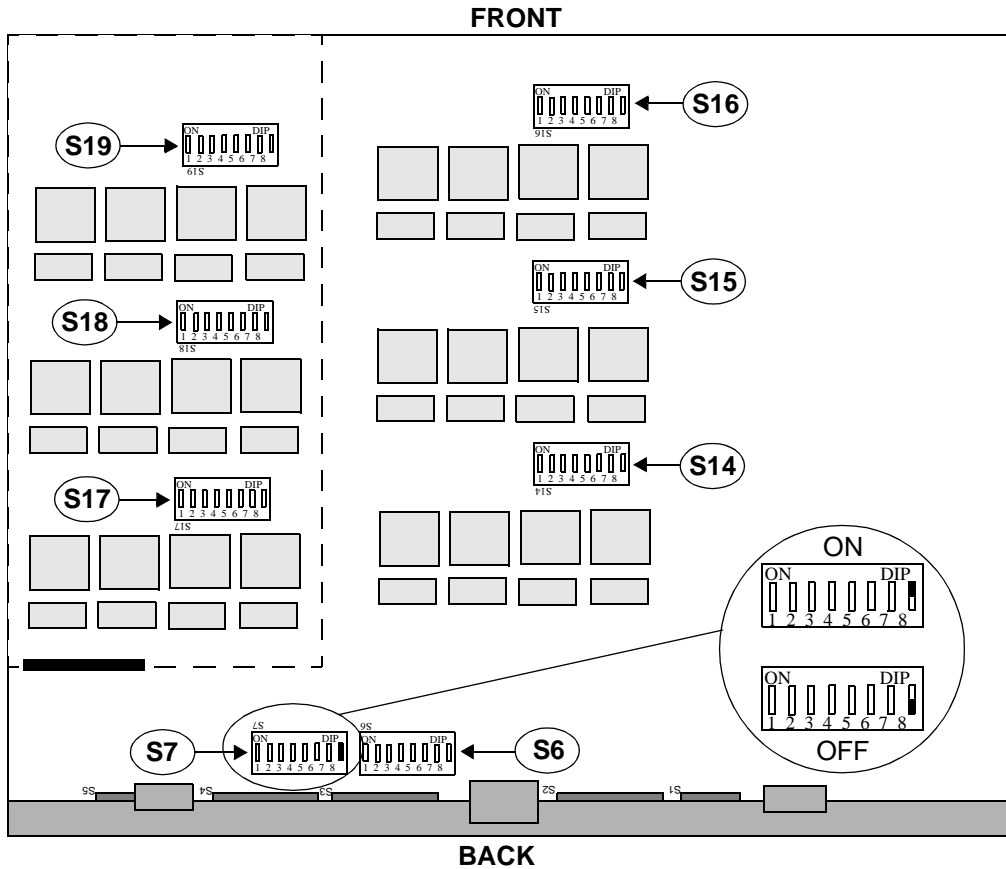

**Description:** S7 position 8 selects the timeslot assignments.

**Factory Setting:** OFF

**OFF:** FXS Ports 1-12 are mapped onto T1 time slots 1-12 and FXS Ports 13-24 are mapped onto T1 time slots 13-24.

**Swap (ON):** FXS Ports 1-12 are mapped onto T1 time slots 13-24 and FXS Ports 13-24 are mapped onto T1 time slots 1-12. Swap is available only on switch 7 and is applicable only on the 12 port model.

Depending on the services provided by your carrier for voice and data, you may need to reassign the FXS timeslots of the 12 FXS port model. Timeslots 13 to 24 will be assigned in order to allocate data to the lower timeslots.

The DIP switch setting shown in the illustration above is for Switch S7 **ONLY**.

## External DIP Switches

The ICX-250 is equipped with five external DIP switches (*four - 12 dip switches, and one - 7 dip switch*) located on the rear panel of the unit. These switches are used for Data Port and T1 Configuration. Each switch is set to a preconfigured factory setting when shipped. The illustration below outlines the location of these DIP switches.



**Note:** The individual switches on each switch assembly operate independently of one another.

### ICX-250 - Rear Panel

Switch numbers S1 through S5 are shown on the board within the unit.

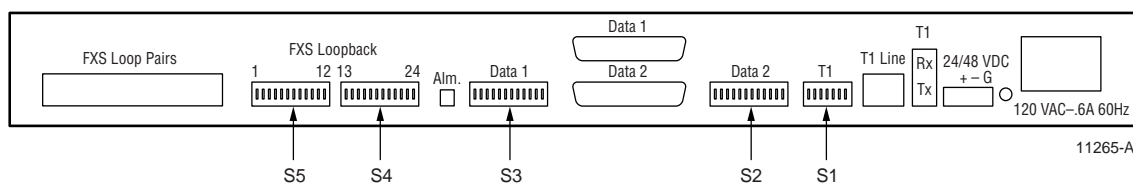

## DIP Switch Settings

Locate the DIP switch on the rear panel that describes the function you wish to effect. Use the tip of a small object to change the switch settings. The switches will glide easily into place.

### TIP



Switch setting changes will take effect immediately.

**T1 Interface - Frame Format (DIP switch - back)****ICX-250 - Rear Panel**

Switch numbers S1 through S5 are shown on the board within the unit.

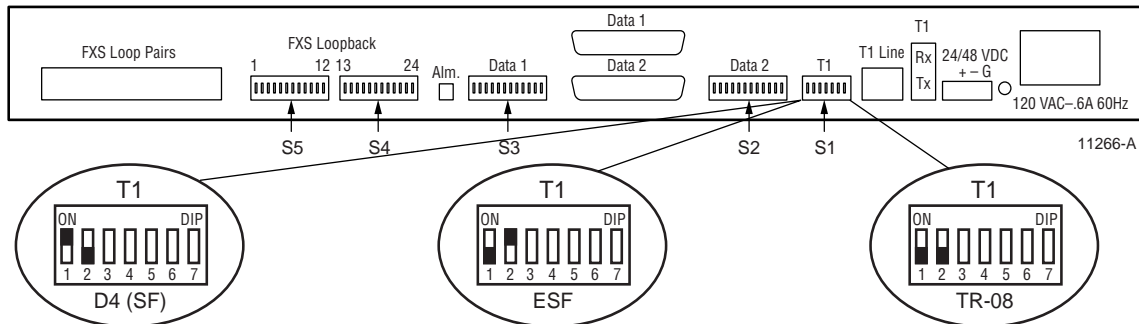

**Description:** S1 positions 1 and 2 are used to select the T1 frame format.

**Factory Setting:** ESF

**Framing:** Selects the T1 frame format to be either D4 (SF), ESF, or TR-08. (No data link with D4)

**Selections:** D4 (SF), ESF and TR-08. (Note: Position 1 and 2 to ON is not a valid setting and could cause slips on the T1.)

**T1 Interface - Line Code (DIP switch - back)****ICX-250 - Rear Panel**

Switch numbers S1 through S5 are shown on the board within the unit.

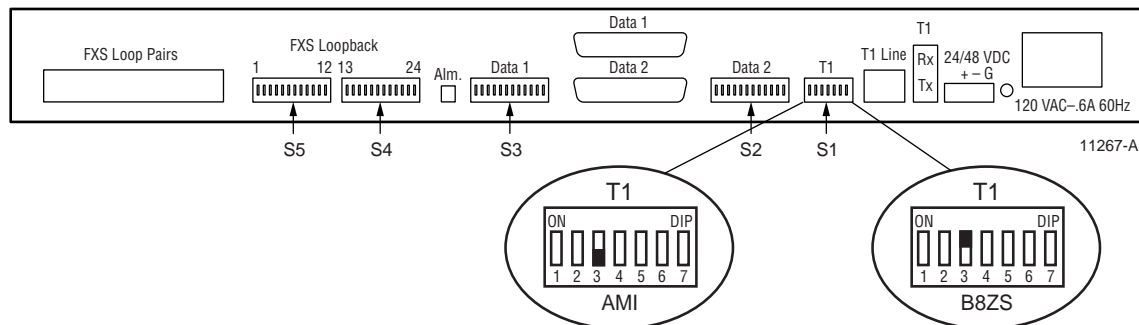

**Description:** S1 position 3 is used to select the T1 line code.

**Factory Setting:** B8ZS

**Line Code:** Selects the line code on the T1 interface.

**Selections:** AMI, B8ZS.

**T1 Interface - T1 Clock (DIP switch - back)****ICX-250 - Rear Panel**

Switch numbers S1 through S5 are shown on the board within the unit.

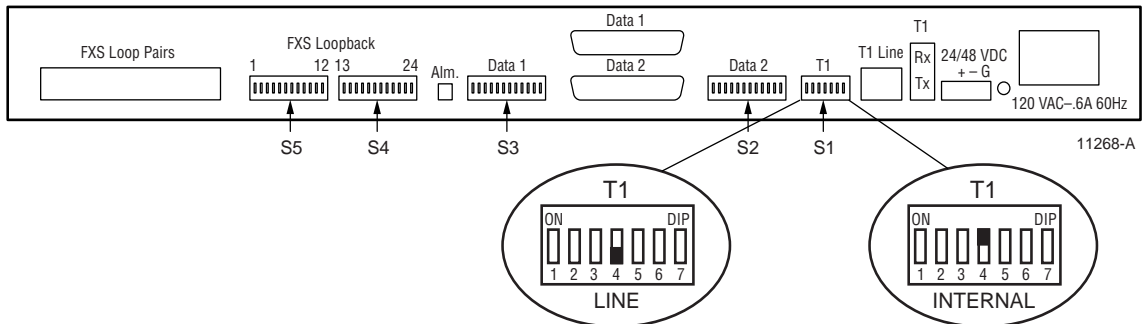

**Description:** S1 position 4 is used to select the T1 clock source.

**Factory Setting:** LINE

**Line:** Clock for the T1 interface will be recovered from the line (receive signal).

**Internal:** Clock for the T1 interface will be taken from an on-board 1.544 MHz clock meeting the Stratum 4 requirements.



**Note:** Failure of external clock causes unit to switch to internal clock. When external clock is restored, the unit will switch back to external clock source.

### T1 Interface - CSU/DSX Interface Selection (*Dip switch - back*)

#### ICX-250 - Rear Panel

Switch numbers S1 through S5 are shown on the board within the unit.

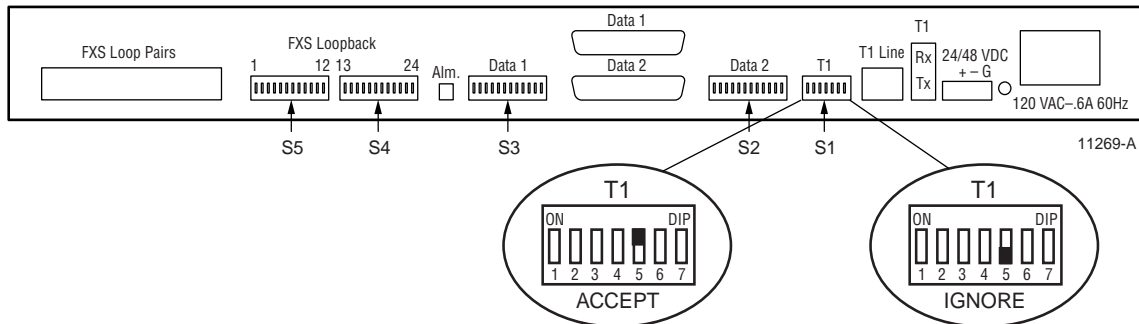

**Description:** S1 position 5 is used to select whether the T1 acts as a CSU or DSX interface.

**Factory Setting:** CSU

**DSX:** SlimLine will exhibit DSX interface characteristics.

**CSU:** SlimLine will exhibit CSU interface characteristics.

### T1 Interface - CSU/DSX Line Build Out (CSU) or Line Length (DSX) (*DIP switch - back*)

#### ICX-250 - Rear Panel

Switch numbers S1 through S5 are shown on the board within the unit.

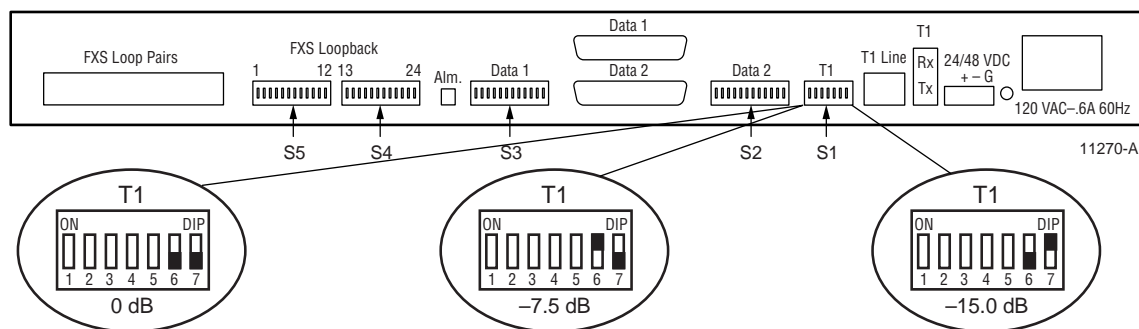

**Description:** S1 position 6 and 7 are used to select CSU/DSX line build out or line length.

**Factory Setting:** CSU 0dB

**Line Build Out:** Selects one of three line build out and line length options for either CSU or DSX interfaces.

**Selections:** CSU 0 dB, -7.5 dB and -15.0 dB; DSX 0.6 dB at 250 ft, 1.8 dB at 500 ft, 3.0 dB at 700 ft.

Data Port 1 and 2 - Number of Timeslots (*DIP switch - back*)

## IICX-250 - Rear Panel

Switch numbers S1 through S5 are shown on the board within the unit.

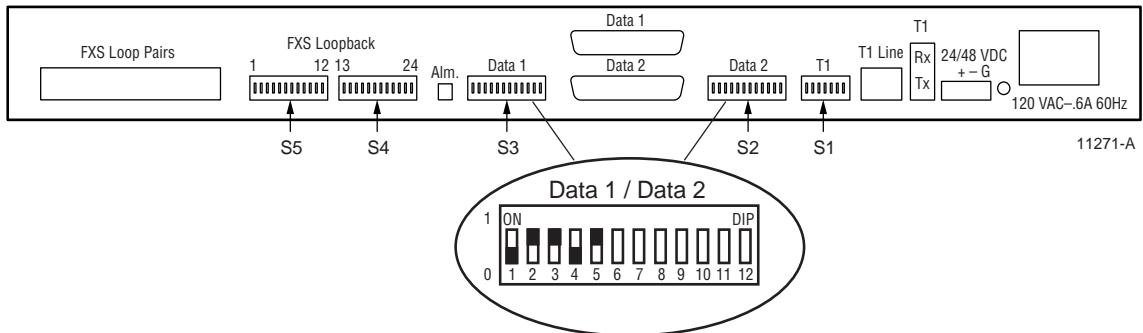

**Description:** S2 positions 1, 2, 3, 4 and 5 (Data 2 - DIP switch) sets the port parameters for Data Port 2. S3 positions 1, 2, 3, 4 and 5 (Data 1 -DIP switch) sets the port parameters for Data Port 1. Both DIP switches are used for Network Data Bandwidth.

**Factory Setting:** All switches are set to zero (data ports inactive).

**Number of Timeslots:** Selects the number of consecutive timeslots that data from Data Port 1 and/or 2 will be mapped onto. Please refer to Decimal/Binary Conversion Table (see page 36) for Data Port Configuration to aid in selecting *N*. Drawing above indicates switch settings if timeslot *N* = 13. Selected quantity of timeslots x 64K = Data Port Bandwidth.



**Note:** Binary numbers are used to select the number of timeslots and starting timeslots.



### Decimal / Binary Conversion Table for Data Port Configuration

The table shown below illustrates the binary equivalent of Timeslots 1-24.  
Note: 1 = ON and 0 = OFF.

Bandwidth	Timeslot	Switch Setting	Bandwidth	Timeslot	Switch Setting
--	0	00000	832K	13	01101
64K	1	00001	896K	14	01110
128K	2	00010	960K	15	01111
192K	3	00011	1024K	16	10000
256K	4	00100	1088K	17	10001
320K	5	00101	1152K	18	10010
384K	6	00110	1216K	19	10011
448K	7	00111	1280K	20	10100
512K	8	01000	1344K	21	10101
576K	9	01001	1408K	22	10110
640K	10	01010	1472K	23	10111
704K	11	01011	1536K	24	11000
768K	12	01100			

Starting T/S	6	7	8	9
1	off	off	off	off
3	off	off	off	on
5	off	off	on	off
7	off	off	on	on
9	off	on	off	off
11	off	on	off	on
13	off	on	on	off
15	off	on	on	on
19	on	off	off	on
21	on	off	on	off
23	on	off	on	on

This table is used for selecting the starting timeslots for each data port.

Data Port 1 and 2 - Starting Timeslot (*DIP switch - back*)

## ICX-250 - Rear Panel

Switch numbers S1 through S5 are shown on the board within the unit.

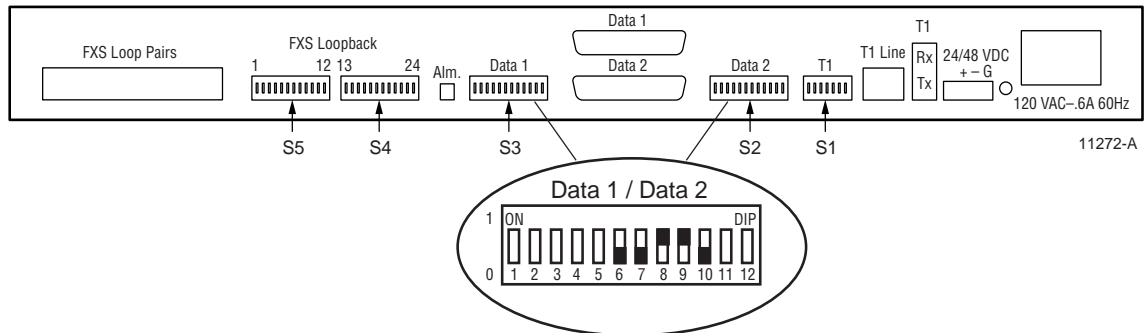

**Note:** Starting time slots will always be odd numbered (i.e. 1, 3, 5, 7, 9, etc.).

**Description:** S2 position 6, 7, 8 and 9 selects the starting timeslot (1,3,5,7,9,etc.) for Data Port 2. S3 position 6, 7, 8 and 9 selects the starting timeslot (1,3,5,7,9,etc.) for data port 1.

**Factory Setting:** All switches are set to zero (data ports not active).

**Starting Timeslot:** Selects first T1 timeslot that data from Data Port 1 and/or 2 will be mapped. (1,3,5,7,9....23). Please refer to Decimal/Binary Conversion Table (see page 36) to aid in selecting the starting timeslot. Drawing above indicates switch settings using timeslot 6 as the starting timeslot.



**Factory Setting:** All switches are set to zero (data ports not active).

Data Port 1 and 2 - Clock Inversion - (DIP switch - back)

ICX-250 - Rear Panel

Switch numbers S1 through S5 are shown on the board within the unit.

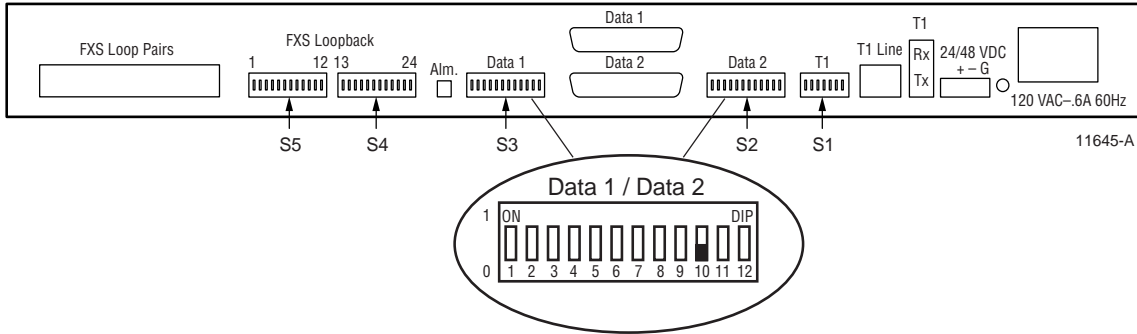

**Description:** DTE clocking will usually require an off setting (S2 & S3 position 10 off). If synchronization problems occur, clock inversion should be selected (S2 & S3 position 10 on).

**Factory Setting:** Clock set to OFF

Data Port 1 and 2 - Data Interface Type - (DIP switch - back)

ICX-250 - Rear Panel

Switch numbers S1 through S5 are shown on the board within the unit.

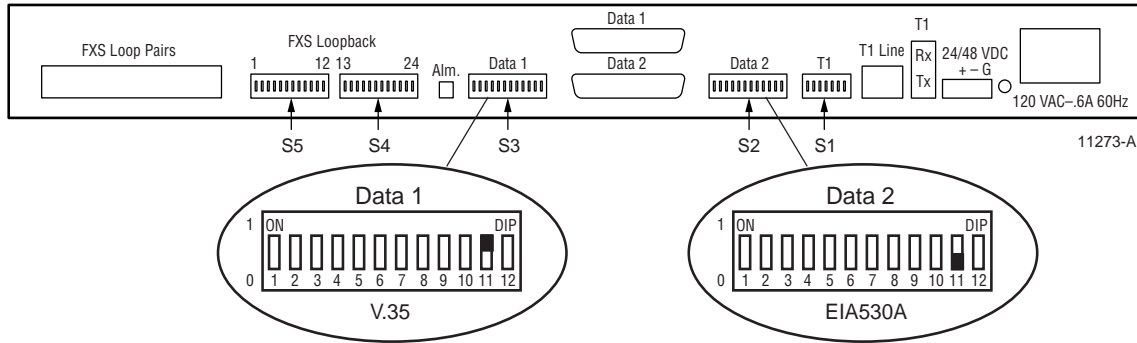

**Description:** S2 and S3 position 11 selects the data interface for Data Ports 2 and 1.

**Factory Setting:** V.35

**EIA530A:** Data Ports 1 or 2 use the EIA530A standard.

**V.35:** Data Ports 1 or 2 use the V.35 standard.

**Data Port 1 and 2 Data Rate - (DIP switch - back)****ICX-250 - Rear Panel**

Switch numbers S1 through S5 are shown on the board within the unit.

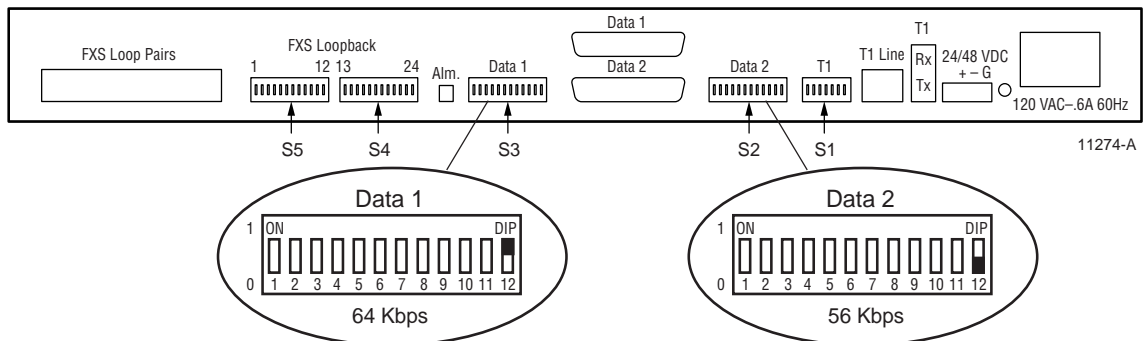

**Description:** S2 and S3 position 12 selects the data rate for Data Ports 2 and 1, respectively.

**Factory Setting:** 56Kbps

**64 Kbps:** Data Ports 1 or 2 receive and transmit data at a multiple of 64 Kbps.

**56 Kbps:** Data Ports 1 or 2 receive and transmit data at a multiple of 56 Kbps.

The options shown on this page do not have to be matched. i.e. Port 1 can have a different interface and speed than Port 2.

**FXS Ports (per line) - Loopback Operation and/or Channel Unassigned (DIP switch - back)****ICX-250 - Rear Panel**

Switch numbers S1 through S5 are shown on the board within the unit.

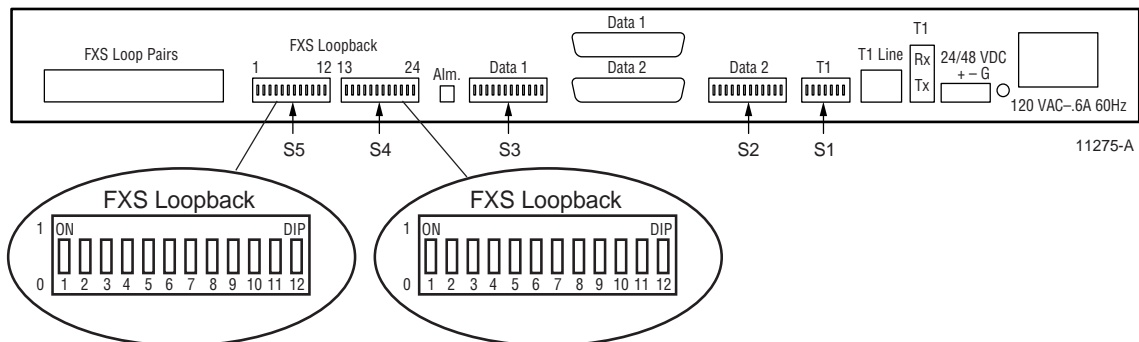

**Description:** Used to set loopback for each FXS channel.

**Factory Setting:** OFF

**ON:** Breaks the connections to and from the FXS Ports and loops the receive data back onto the transmit path towards the T1. In the case of unassigned channels, provides an idle termination.



**Note:** It is recommended that all unassigned channels be provided an idle termination.

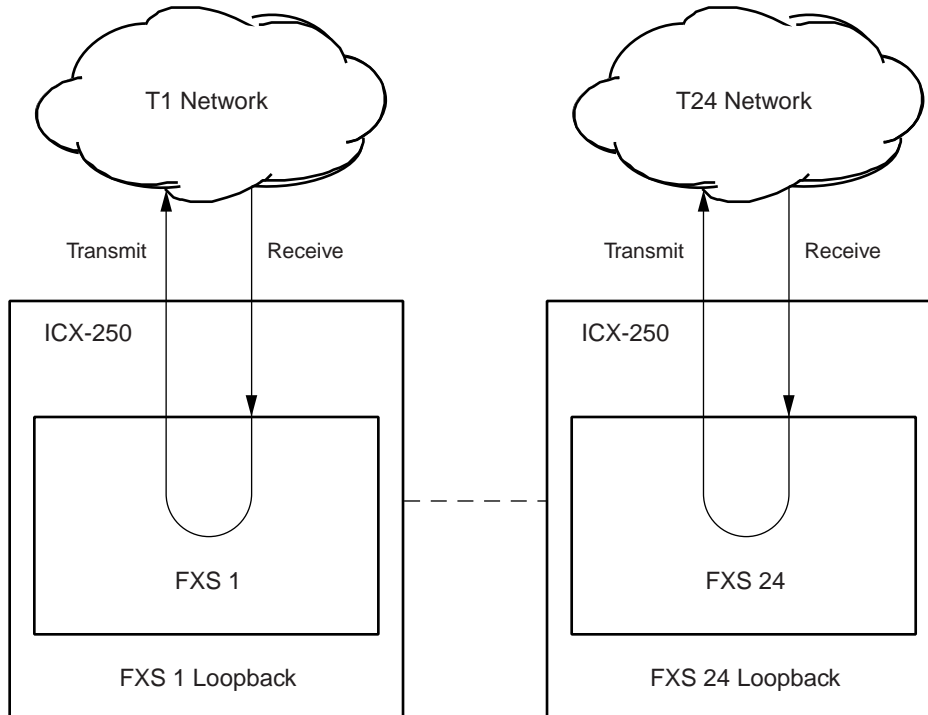

The selected DS0 is looped after leaving the framer before reaching the FXS Interface. The CPU is used to control this loopback via the Time Slot Assigner (TSA, a part of the CPU). Subsystems T1 Line Interface Unit, T1 Framer, and CPU are exercised.

11276-A

# Configuration Reference Data

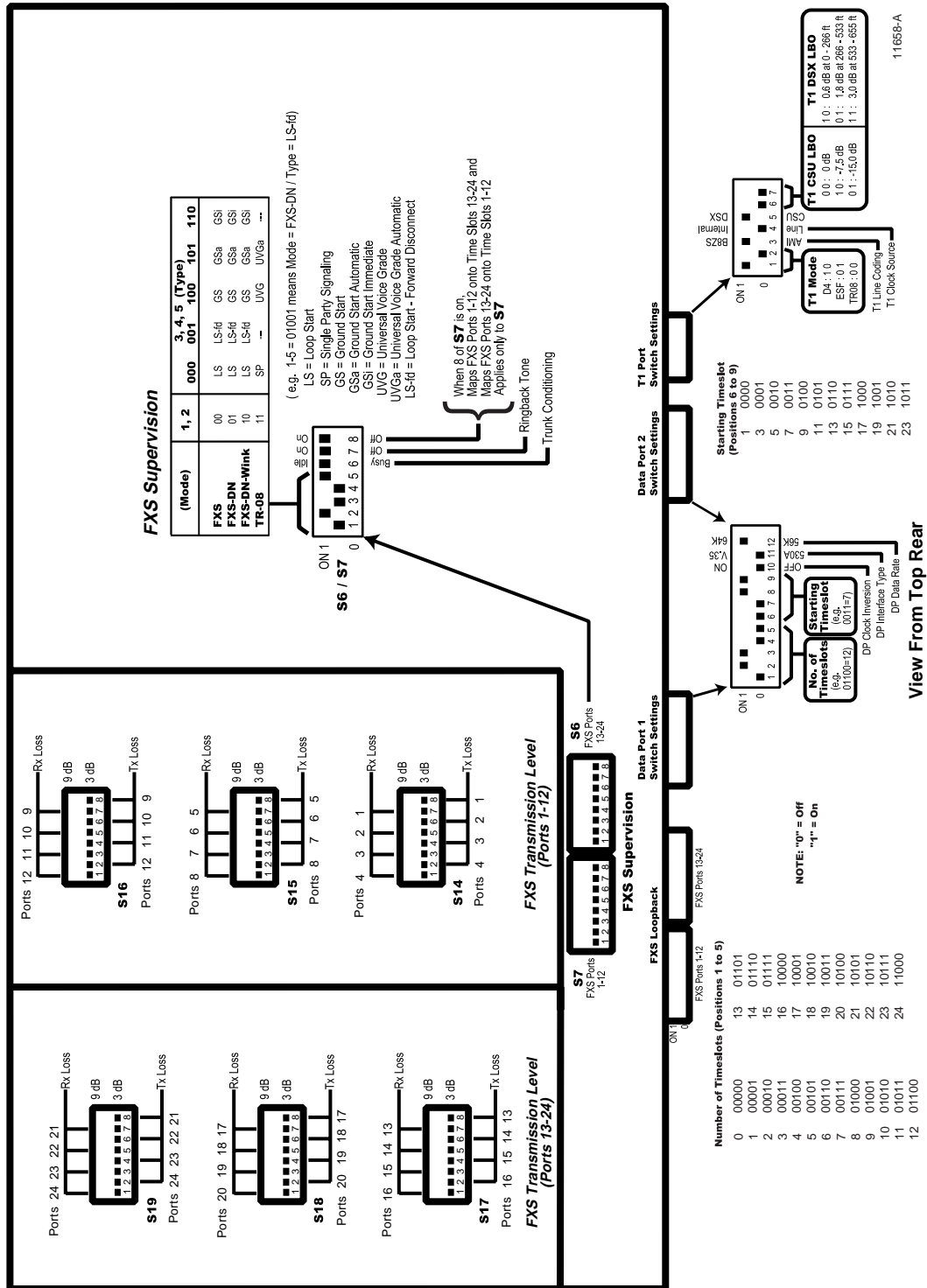

## CHAPTER 4



# Electrical Installation

When you are ready to go beyond the basics of the ICX-250 unit, use this chapter to learn specifics on grounding, cabling, and the necessary power requirements for operation.

## Contents

Connector Type .....	44
Power Requirements .....	47

## Connector Type

The ICX-250 product is equipped with several types of electrical connections to the network and power sources. The table below lists each one of the connectors along with their functionality.

### ICX-250 - Rear Panel

Switch numbers S1 through S5 are shown on the board within the unit.

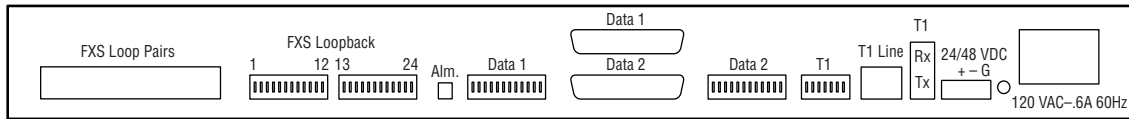

11264-A

Connector Name	Connector Type	Description
FXS Loop Pairs	25 Pair Amphenol	24 FXS Tip and Ring pair Signals: TIPn, RINGn switch for FXS.
Alm.	2 position (plug included with Kit of Parts)	A relay closure that sends alarms out to an external alarm system.
Data 1 and Data 2	DB25 Female	Data Port 1 signals and Data Port 2 signals.
T1 Line	RJ48	Transmit and Receive pairs.
T1	Dual Bantam Jack (monitor jacks)	For bridged access onto the T1 transmit and receive pairs.
24/48VDC (+- G) 1.8 / .9A Max.	3 position (plug included with Kit of Parts)	For DC power input. <b>Note:</b> FXSGND must be connected to earth ground regardless of powering method used.
120 VAC -.6A 60Hz	AC Receptacle	Power input when external 120 VAC 60Hz is used to power the unit.
	Earth Ground	Permanent Earth Ground Connection.



## Connector Pinouts

### DCE DB25 Female Connector (Data Ports 1 and 2)

Pin	Signal	Name	Mnemonic	Source	V.35	EIA-530A
1	Shield					X
2	Transmit Data	TXD+	BA (A)	DTE	X	X
3	Receive Data	RXD+	BB (A)	DCE	X	X
4	Request to Send	RTS+	CA (A)	DTE	X	X
5	Clear to Send	CTS+	CB (A)	DCE	X	X
6	DCE Ready	DSR+	CC	DCE	X	X
7	Signal Common		AB		X	X
8	Receive Line Signal Detector	DCD+	CF (A)	DCE	X	X
9	Receive Signal Element Timing	RXCLK-	DD (B)	DCE	X	X
10	Receive Line Signal Detector	DCD-	CF (B)	DCE		X
11	Transmit Signal Element Timing (DTE)	TXCLK	DA (B)	DTE		X
12	Transmit Signal Element Timing (DCE)	TXCLK-	DB (B)	DCE	X	X
13	Clear to Send	CTS-	CB (B)	DCE		X
14	Transmit Data	TXD-	BA (B)	DTE	X	X
15	Transmit Signal Element Timing (DCE)	TXCLK+	DB (A)	DCE	X	X
16	Receive Data	RXD-	BB (B)	DCE	X	X
17	Receive Signal Element Timing (DCE)	RXCLK+	DD (A)	DCE	X	X
18	Local Loopback	LL	LL	DTE		X
19	Request to Send	RTS-	CA (B)	DTE		X
20	DTE Ready	DTR+	CD	DTE		X
21	Remote Loopback	RL	RL	DTE		X
22	Ring Indicator		CE	DCE		X
23	Signal Common		AC			X
24	Transmit Signal Element Timing (DTE)	TXCLK	DA (A)	DCE		
25	Test Mode	TM	TM			X



**Note:** For purposes of connection and function, the ICX-250 should be considered a DCE.

## 25 Pair Female Amphenol Connector

Port	Designation	Pin	Port	Designation	Pin
1	T	26	13	T	38
1	R	1	13	R	13
2	T	27	14	T	39
2	R	2	14	R	14
3	T	28	15	T	40
3	R	3	15	R	15
4	T	29	16	T	41
4	R	4	16	R	16
5	T	30	17	T	42
5	R	5	17	R	17
6	T	31	18	T	43
6	R	6	18	R	18
7	T	32	19	T	44
7	R	7	19	R	19
8	T	33	20	T	45
8	R	8	20	R	20
9	T	34	21	T	46
9	R	9	21	R	21
10	T	35	22	T	47
10	R	10	22	R	22
11	T	36	23	T	48
11	R	11	23	R	23
12	T	37	24	T	49
12	R	12	24	R	24
				Not Assigned	50
				Not Assigned	25

## RJ48 Connector

RJ-48(F) Pin	Signal
1	R1
2	T1
4	R
5	T
3,6,7,8	Not Assigned

# Power Requirements

The installation site should have a 120VAC power receptacle readily available to power up the unit. The unit can also be powered by  $-48\text{VDC}$  or  $\pm 24\text{VDC}$ .

## Power Installation

### A.C. Power Installation

The ICX-250 unit is equipped with an AC receptacle located on the back of the unit.

### D.C. Power Installation

When wiring to an external power source, such as a battery rack, fuse panel, or circuit breaker, make sure that the correct rating of wire is used. It is recommended you use 20 to 18 gauge wire.



**Note:** The ICX-250 unit can have both an AC and DC power source connected to it at the same time. These two power inputs will share the power load. However, if one fails the other will carry the full load.

### DC Power Plug (supplied)

wire tightening screws  
(located on top of adapter)



Wire  
(not supplied)

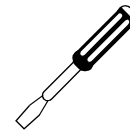
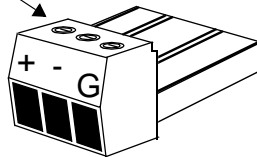

Small Screwdriver  
(not supplied)

## Alarm

The ICX-250 unit is equipped with an external alarm connector (located on the rear panel of the unit) that will close in the event of an alarm condition such as: T1 failure, internal failure, or power failure. A Red alarm is detected by the T1 interface and responded to by issuing the yellow alarm signal on the T1. The figure below illustrates the alarm connector. It is recommended you use 26 to 24 gauge twisted-pair wire.

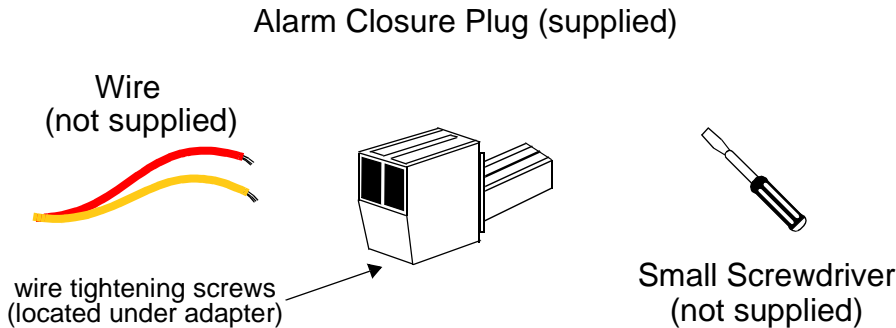

## Grounding Requirements

Due to the UL regulatory requirements, a mounting stud is required for connection of the AC input earth ground lead to the ICX-250 chassis. The ground lead must be connected to the chassis using a No. 6 nut and lock washer combination. The mounting location is labeled with the IEC 417 No. 5019 symbol ( $\oplus$ ) to identify this as the AC earth ground connection point. This mounting stud is located next to the IEC 320 AC input connector.

The loop battery return and the FXS digital and analog circuitry must share a common ground. The access point on the back panel of the ICX-250 product allows connection to an external battery return lead which will be physically connected to the FXS circuit ground. This access point is provided as part of the DC power input connector.

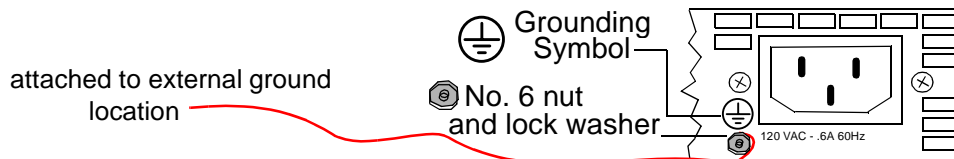

## Cabling

The following cables are recommended for use with the ICX-250 unit.

Cable	Used for	Description
Voice	FXS Ports	50-pin Amphenol (M) to 50 pin Amphenol (M) (5')
Data	Data Ports EIA530A	DB25M to DB25F (Straight through) (5')
Data	Data Ports V.35	DB25M to M34F (Straight through) (5')
T1	RJ48 Port	RJ48M to RJ48M Shielded (1')
T1	RJ48 Port	RJ48M to RJ48M Shielded (25')
AC Power	AC Power Input	AC Power Cable (6')

## CHAPTER 5

# ICX-250 Diagnostics



This chapter describes how to run test patterns and to diagnose events taking place within the ICX-250 unit.

## Contents

Testing .....	52
LED Indicators .....	61

# Testing

## Slide Switch Settings

The ICX-250 is equipped with five external slide switches (*four - 3 position, one - 2 position*) located on the front panel of the unit. They are used for T1 and Data Port test and Loopback Transmit / Receive paths. Each switch is factory set to the off position. The switches should be checked to be sure positioning hasn't changed during shipment. The illustration below outlines the location of the slide switches.

Locate the slide switch on the front panel that implements the function desired. Use the end of a small object or the tip of your finger to change the switch settings.

### ICX-250 - Front Panel

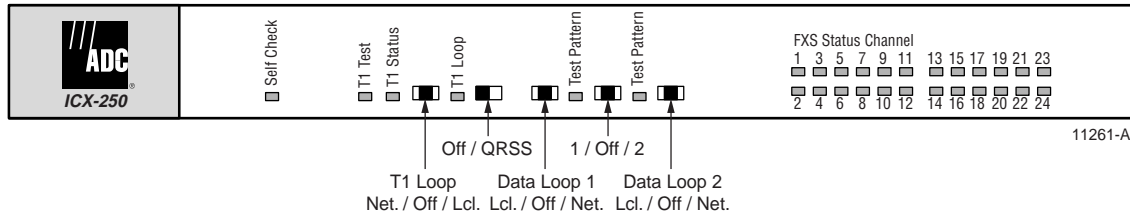

11261-A

#### TIP



**Switch setting changes will take effect immediately.**

The bold highlighted selected under "Options" is the Factory Setting.				
Function	Switch	Switch Location	Options	Description
<b>T1 INTERFACE:</b>				
<b>T1 Interface T1 Loopback (see page 54)</b>	T1 Loopback	Front (slide)	Network Local <b>Off</b>	<b>Network:</b> Loops signal back to the network and breaks the transmit and receive paths between the Framer and LIU and loops T1 receive onto the T1 transmit within the Framer chip. <b>Local:</b> Loops signal back to the network and breaks the transmit and receive paths between the LIU and the line and loops the T1 transmit signal onto the T1 receive within the LIU.
<b>T1 Test Pattern QRSS (see page 56)</b>	QRSS Quasi Random Signal Source. Used for diagnostic capabilities for analog, remote and dual loopbacks as well as remote test.	Front (slide)	On <b>Off</b>	<b>On:</b> All connections between either Data Ports or the FXS Ports and the T1 interface are broken and a QRSS pattern is transmitted onto the T1 interface. At this time the T1 Test Pattern LED will light when QRSS is being transmitted. <b>Note: ONLY works with framed T1.</b>
<b>DATA PORTS:</b>				
<b>Loopback (see page 58)</b>	Data Port 1 and 2 Loopback	Front (slide)	Local Network <b>Off</b>	<b>Local:</b> Breaks the receive signal on the network side between the Data Port 1 or 2 and the T1 interface and loops the Data Port 1 or 2 transmit signal onto the receive side. <b>Network:</b> Breaks the transmit signal on the network side between the Data Port 1 or 2 and the T1 interface and loops the Data Port 1 or 2 receive signal onto the transmit side.
<b>Test Pattern (see page 60)</b>	1 / Off / 2	Front (slide)	1: Test Port 1 2: Test Port 2 <b>OFF:</b> no Test	<b>1:</b> Breaks the transmit and receive paths between the Data Port 1 line and the receiver and inserts the 2047 pattern onto the transmit path. Also turns on the 2047 receiver. <b>2:</b> Breaks the transmit and receive paths between the Data Port 2 line and the receiver and inserts the 2047 pattern onto the transmit path. Also turns on the 2047 receiver. <b>OFF:</b> 2047 function is disabled.



## T1 Interface - T1 Loopback (Slide switch - front)

### ICX-250 - Front Panel

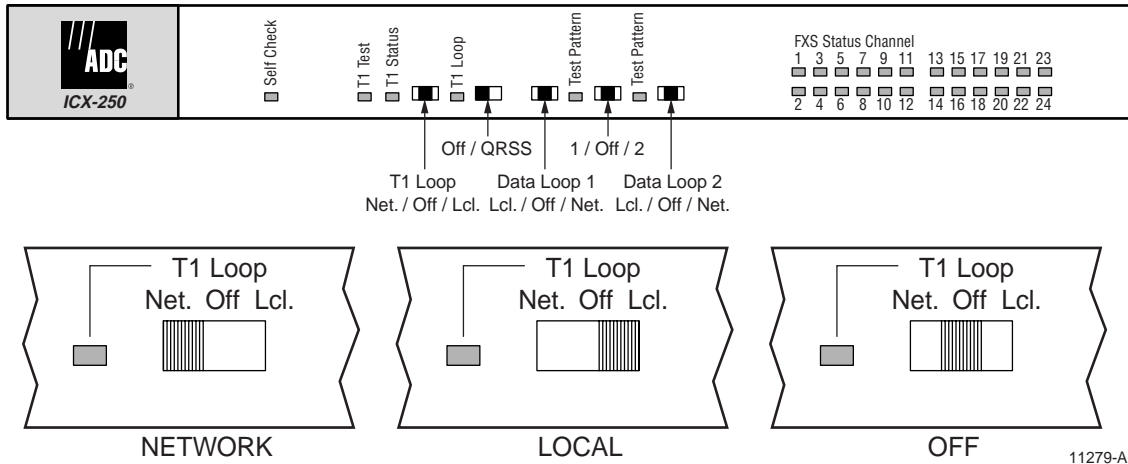

**Description:** This is a three position slide switch used to operate the T1 Interface Loopback.

**Factory Setting:** OFF

**Network:** Loops signal back to the network and breaks the transmit and receive paths between the Framer and LIU and Loops the T1 receive onto the T1 transmit within the Framer chip.

**Local:** Loops signal back to the network and breaks the transmit and receive paths between the LIU and the line and loops the T1 transmit signal onto the T1 receive within the LIU.



**Note:** When operating the QRSS switch the T1 Loopback switch will be inoperative.

## T1 Loopback

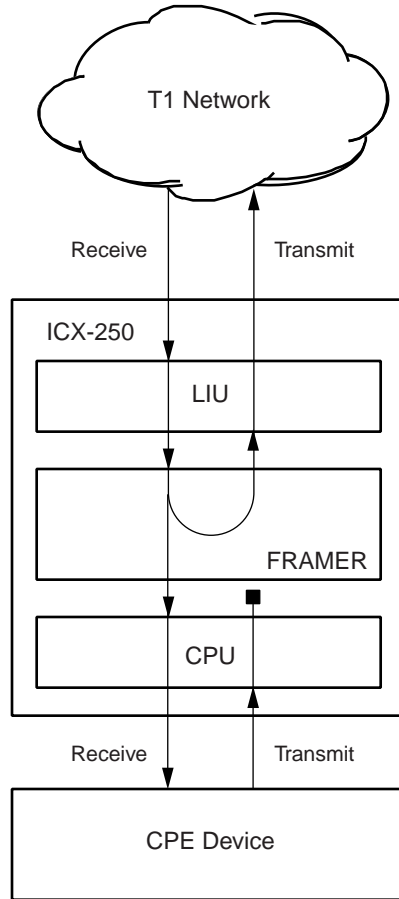

**Network or Remote Loopback**

The incoming T1 signal is looped inside the T1 Framer and returned to the T1 Network. This exercises the T1 Line Interface Unit and the T1 Framer with the exception of the HDLC controller and clock switching circuitry.

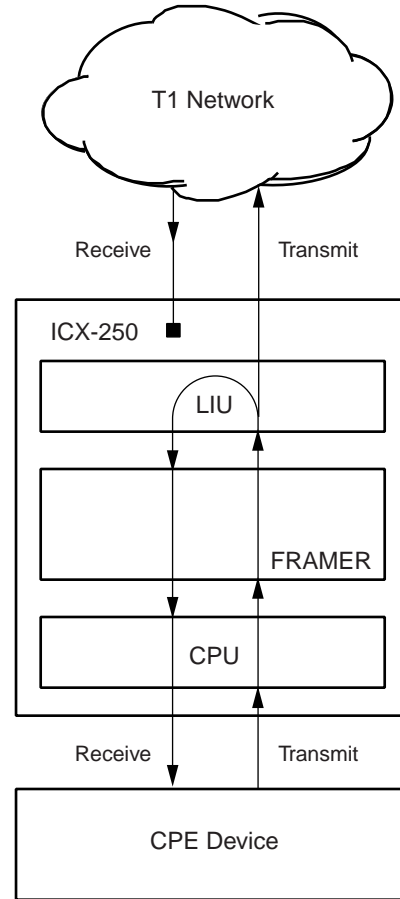

**Local Loopback**

The outgoing T1 signal is looped inside the T1 LIU and returned to the CPE Device. This exercises the T1 Line Interface Unit, the T1 Framer, CPU, Data Port Interface, and the FXS Interface with the exception of the HDLC controller. The data ports can be exercised up to full T1 rate.

11277-A

## T1 Interface - T1 Test Pattern QRSS (Slide switch - front)

### ICX-250 - Front Panel

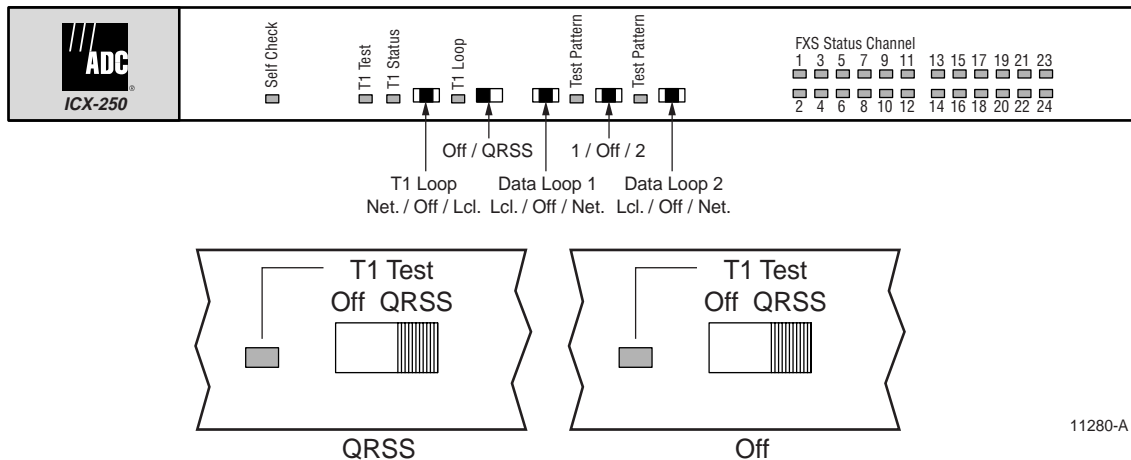

**Description:** This is a two position slide switch used for T1 Interface testing.

**Factory Setting:** OFF

**On:** All connections between either the Data Ports or the FXS Ports and the T1 interface are broken and a QRSS pattern is transmitted onto the T1 interface. At this time the T1 Test pattern LED will light when QRSS is being transmitted. (*see section on LED*).



**Note:** The T1 test pattern for QRSS only works with framed T1.



**Note:** The T1 test LED will come on when the QRSS switch is turned ON. When operating the QRSS switch the T1 Loopback switch will be inoperative.

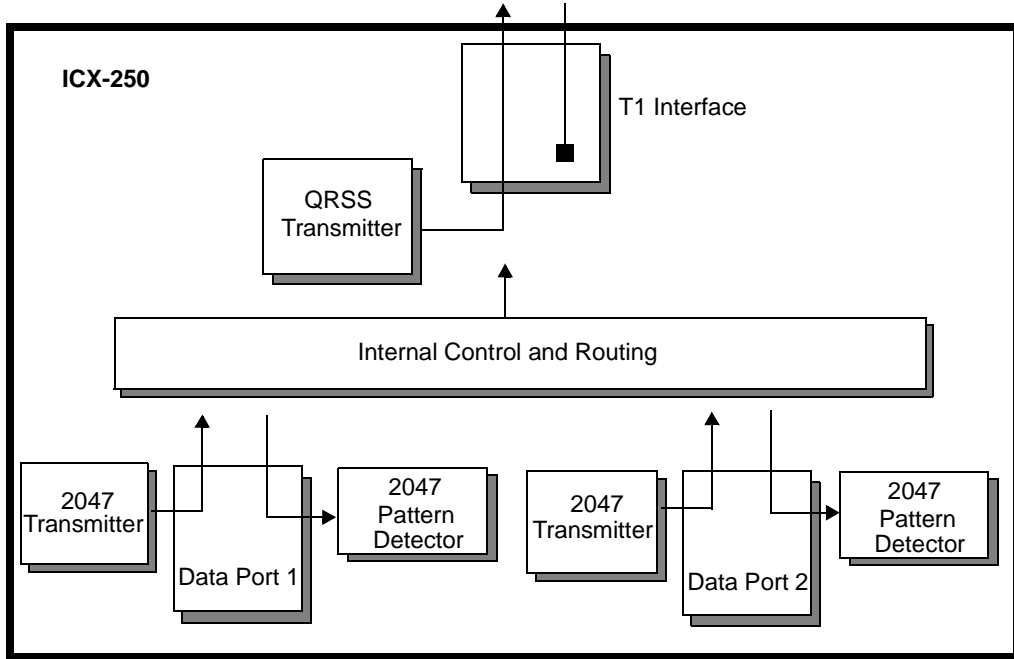

## Data Port 1 and 2 - Loopback (Slide switches - front)

## ICX-250 - Front Panel

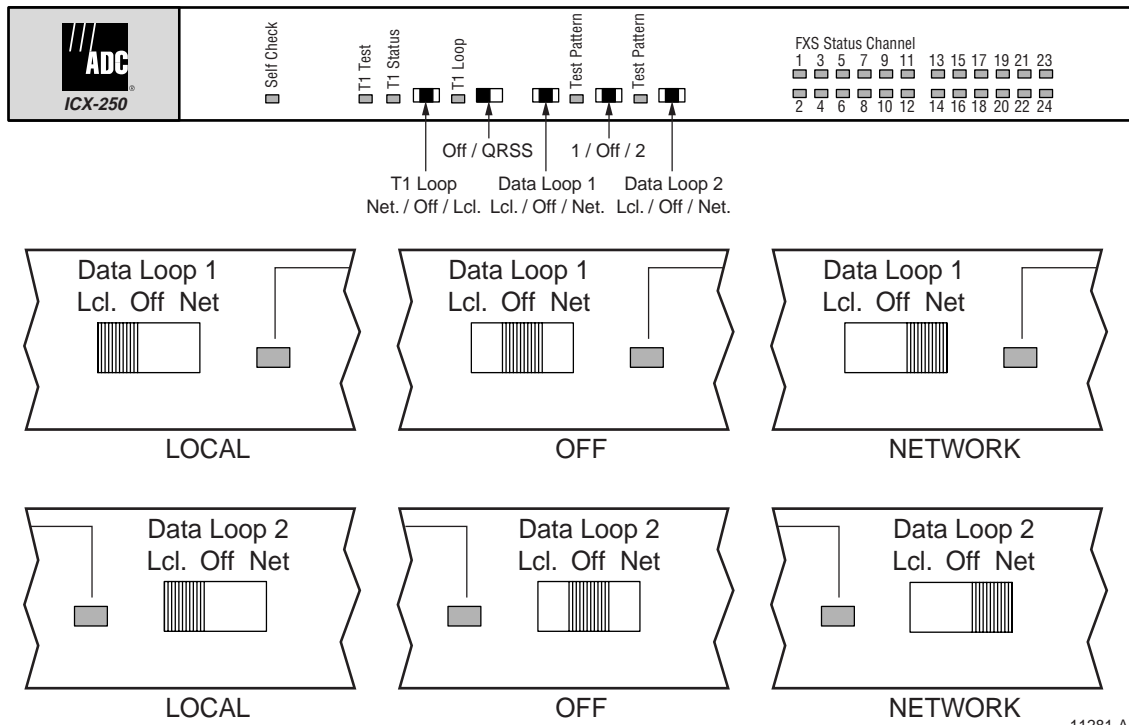

**Description:** This is a three position slide switch used for Data Port 1 and 2 to receive and transmit T1 loopback information.

**Factory Setting:** OFF

**Local:** Breaks the receive signal on the network side between the Data Port (1 or 2) and the T1 interface and loops the Data Port (1 or 2) transmit signal onto the receive side.

**Network:** Breaks the transmit signal on the network side between the Data Port (1 or 2) and the T1 interface and loops the Data Port (1 or 2) receive signal onto the transmit side.

## Data Port 1 and 2 Loopback

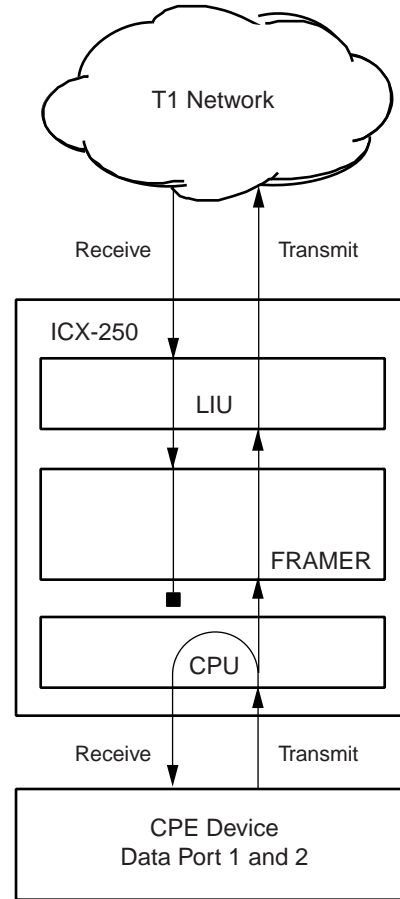
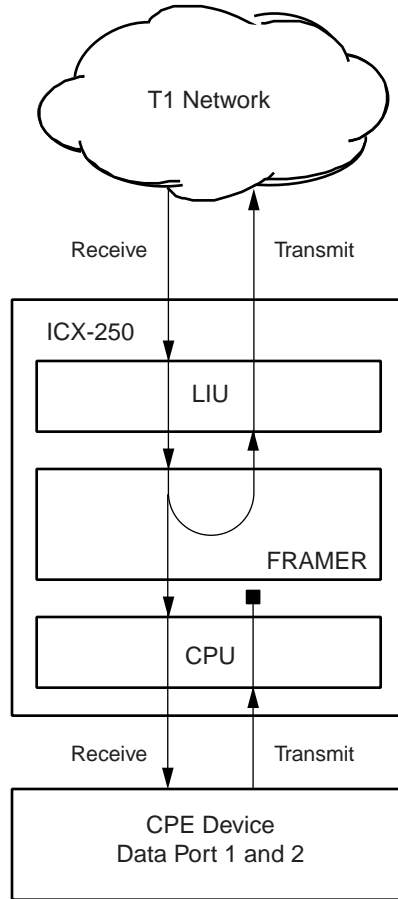

11278-A

### Network or Remote Loopback

The selected DS0s are looped back after leaving the Framer before reaching the CPU. The CPU is used to control this loopback via the TSA. Subsystems T1 Line Interface Unit, T1 Framer, and CPU are exercised.

### Local Loopback

The Data Port interface signal is looped inside the CPU and returned to the data port interface. Subsystems CPU and Data Port interface are exercised.

## Data Port Test (*Slide switch - front*)

### ICX-250 - Front Panel

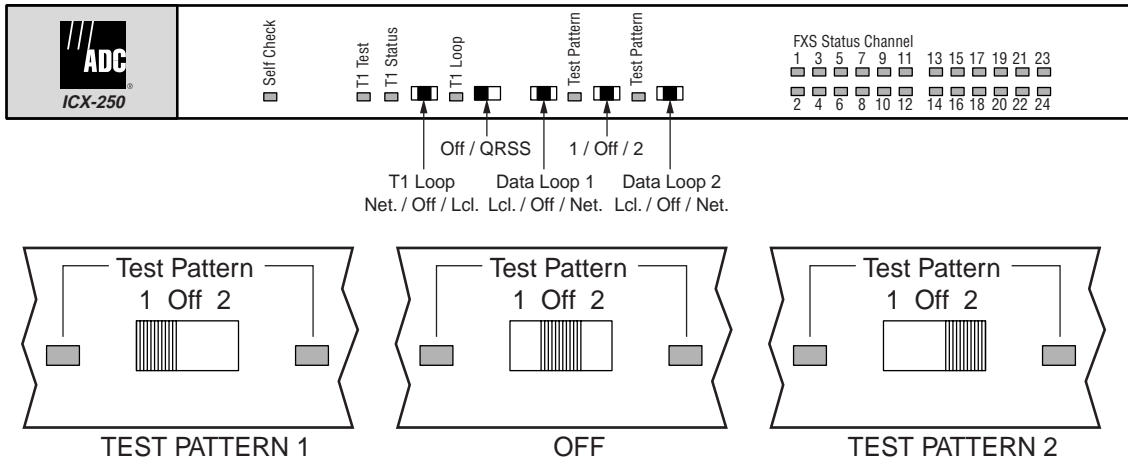

**Description:** This is a three position slide switch used to connect the Test Generator to the Data Port (1 or 2) Transmit side.

**Factory Setting:** OFF

**Test Data Port 1:** Breaks the transmit and receive paths between Data Port 1 and the receiver and injects the 2047 pattern onto the transmit path.

**Test Data Port 2:** Breaks the transmit and receive paths between Data Port 2 and the receiver and injects the 2047 pattern onto the transmit path.

**Off:** 2047 function is disabled.

See diagram on page 55.

# LED Indicators

The LED indicator lights are labeled and located on the front panel of the ICX-250. The table shown below describes the LED location and function.

## ICX-250 - Front Panel

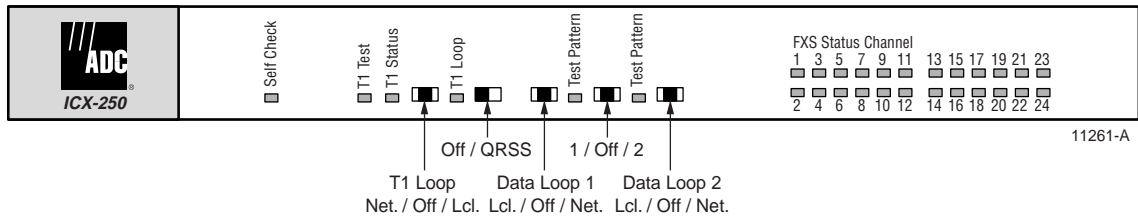

LED	Function	Display Status
<b>Self Check (Red LED)</b>	Self Check (see page 62)	<b>ON:</b> Power-Up Self Test Failed or System Failure occurred. <b>BLINKING:</b> Invalid Configuration
<b>T1 Status (Tri-color LED)</b>	T1 Interface Status (see page 63)	<b>RED:</b> Red Alarm <b>YELLOW:</b> Yellow Alarm <b>GREEN:</b> Normal
<b>T1 Loop (Yellow LED)</b>	(see page 64)	<b>ON:</b> Network <b>BLINKING:</b> Local <b>OFF:</b> None
<b>T1 Test Pattern Sync (Green LED)</b>	(see page 65)	<b>GREEN:</b> QRSS On <b>OFF:</b> No QRSS
<b>Test Pattern Sync (Green LED)</b>	Data Port 1 (see page 66)	<b>GREEN:</b> Sync <b>OFF:</b> No Sync
<b>Test Pattern Sync (Green LED)</b>	Data Port 2 (see page 67)	<b>GREEN:</b> Sync <b>OFF:</b> No Sync
<b>FXS N Connection (Green LED)</b>	FXS Channel Status (x 24) (see page 68)	<b>BLINKING:</b> Call Processing <b>ON:</b> Busy <b>OFF:</b> Idle



**Self Check (Red LED) Failed Power-Up Self Test or System Failure**

**ICX-250 - Front Panel**

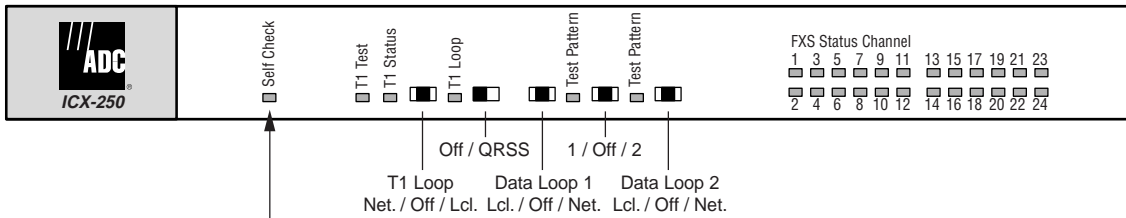

**OFF:** Normal

**ON:** Failed Self Test during power up or a system failure occurred during normal operation.

**BLINKING:** Invalid Configuration

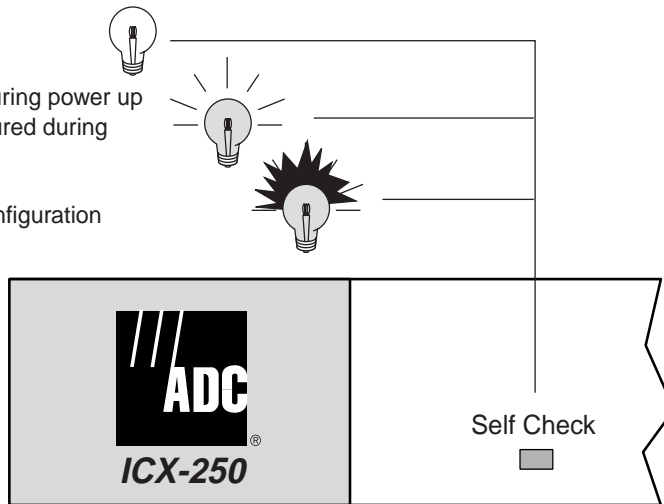

11283-A

T1 Interface Status - (tri-color LED)

ICX-250 - Front Panel

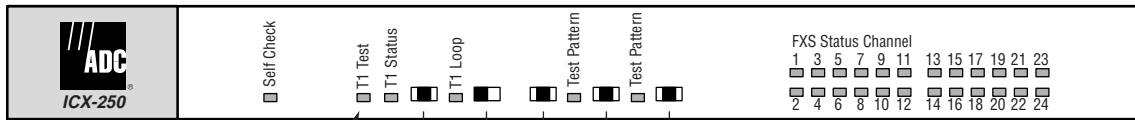

**OFF:** Red Alarm  
Indicates a loss of signal on the receive side of the T1.

**YELLOW:** Yellow Alarm  
Indicates that the near end transmit path is open but that the receive side is intact.

**GREEN:** Normal

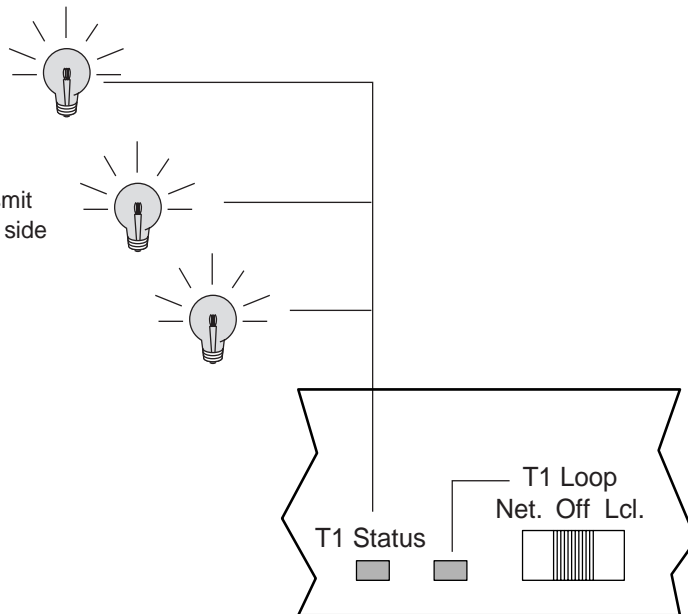

11284-A

### T1 Interface - T1 Loop (Yellow LED)

#### ICX-250 - Front Panel

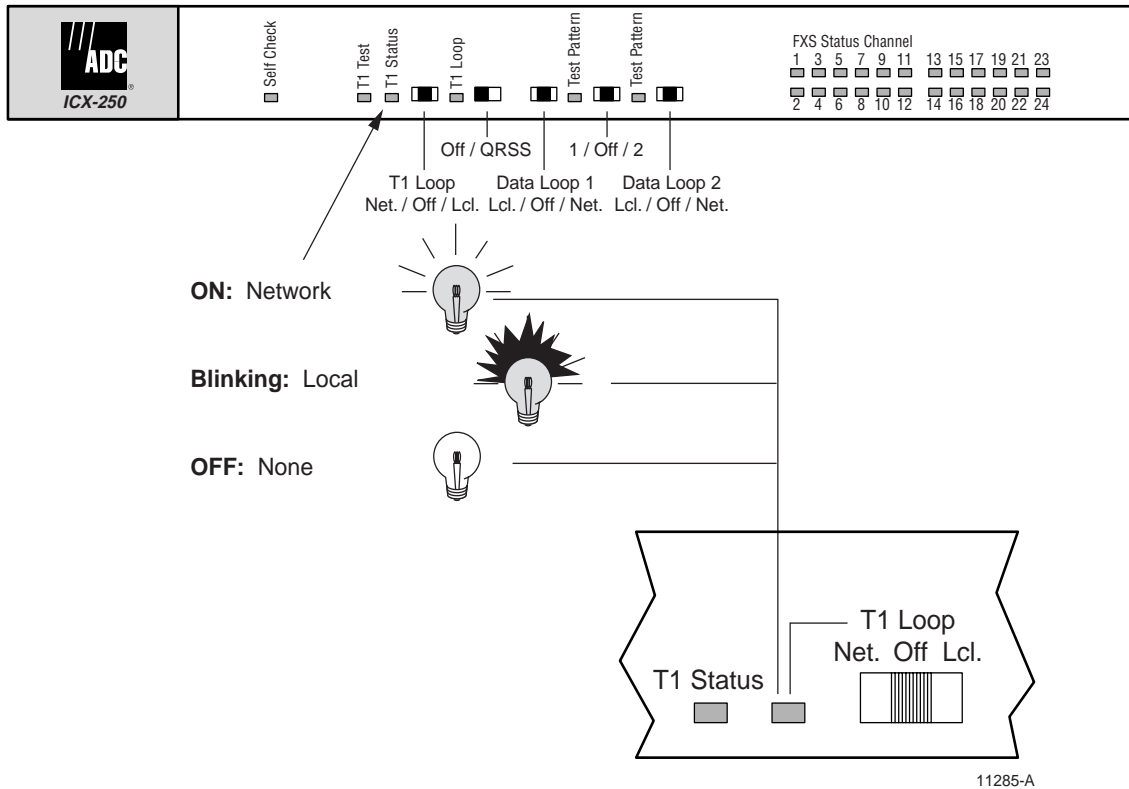

T1 Interface Status - T1 Test Pattern (Green LED)

ICX-250 - Front Panel

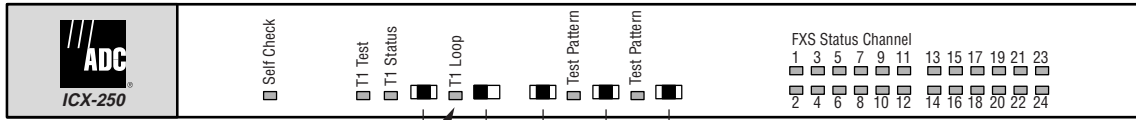

Off / QRSS      1 / Off / 2  
 T1 Loop      Data Loop 1      Data Loop 2  
 Net. / Off / Lcl.      Lcl. / Off / Net.      Lcl. / Off / Net.

**ON:** QRSS Test Mode ON

Indicates that the QRSS Test Pattern is being transmitted out on the T1 towards the network.

**OFF:** QRSS Test Mode OFF

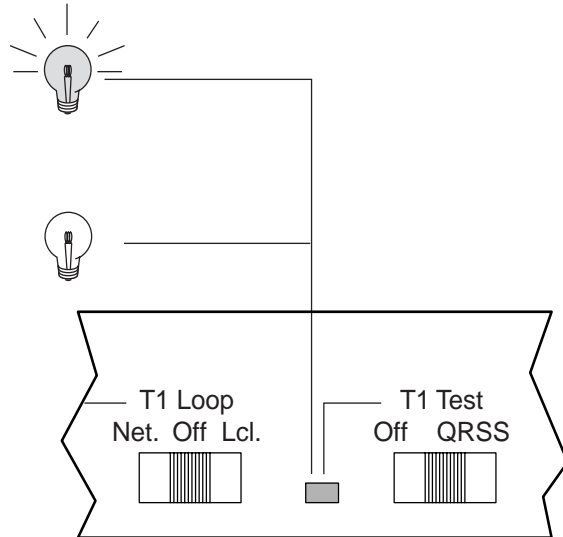

11286-A

## Data Port 1 - Test Pattern Sync (Green LED)

## ICX-250 - Front Panel

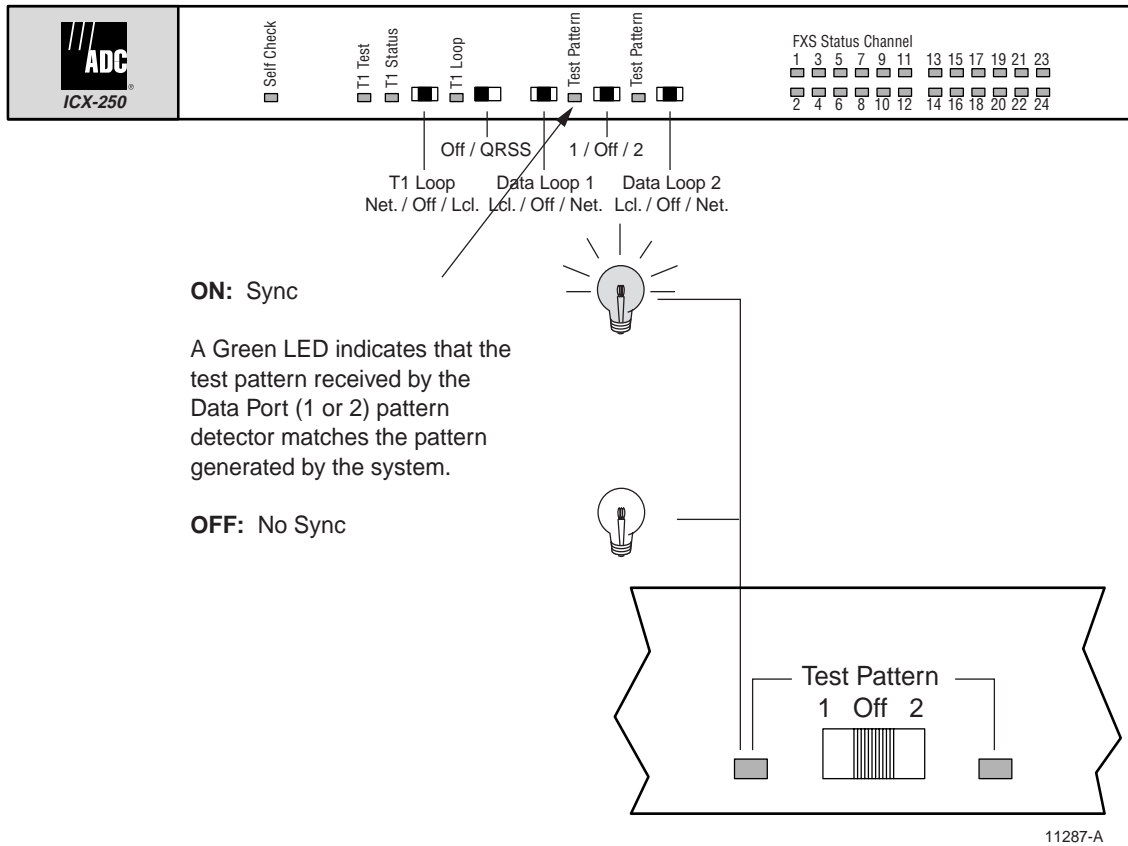

Data Port 2 - Test Pattern Sync (Green LED)

ICX-250 - Front Panel

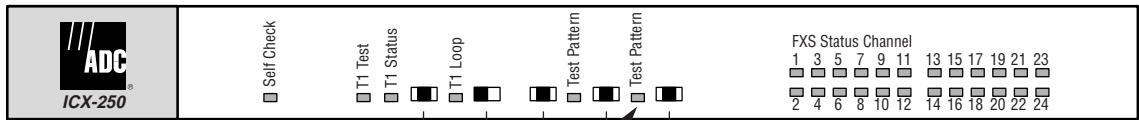

Off / QRSS      1 / Off / 2

T1 Loop      Data Loop 1      Data Loop 2

Net. / Off / Lcl.    Lcl. / Off / Net.    Lcl. / Off / Net.

**ON:** Sync

A Green LED indicates that the test pattern received by the Data Port (1 or 2) pattern detector matches the pattern generated by the system.

**OFF:** No Sync

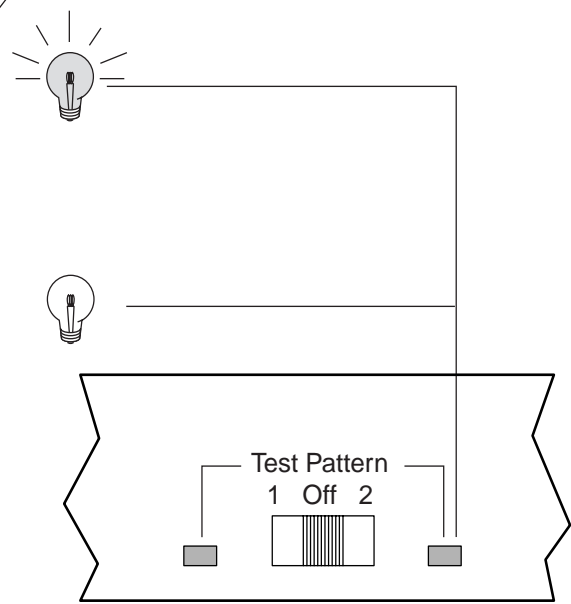

11288-A

**FXS Channel Status - FXS N Connection (Green LED)**

**ICX-250 - Front Panel**

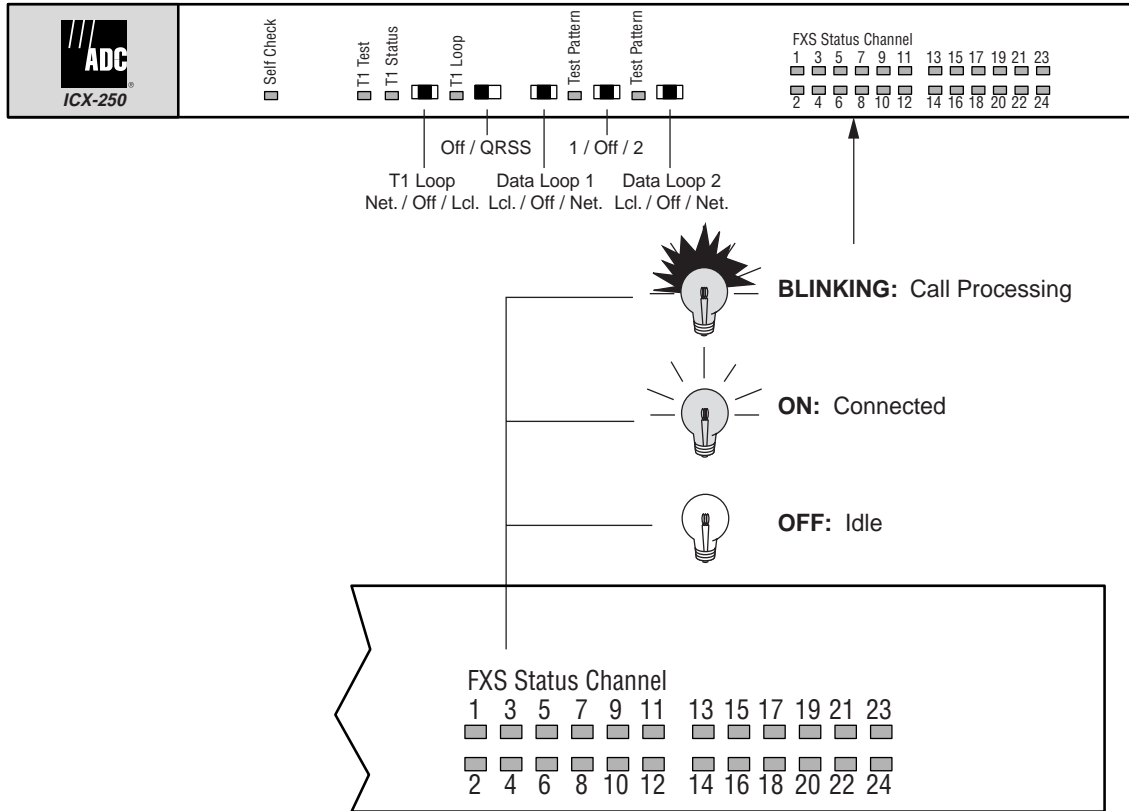

11289-A

## CHAPTER 6

# GENERAL INFORMATION

## WARRANTY/SOFTWARE

The Product and Software warranty policy and warranty period for all Products of ADC Telecommunications, Inc. (hereinafter referred to as ADC) is published in ADC's Warranty/Software Handbook. Contact the Business Broadband Group (BBG) Technical Assistance Center at 1-800-366-3891, extension 3223 (in U.S.A. or Canada) or 612-946-3223 (outside U.S.A. and Canada) for warranty or software information or for a copy of the Warranty/Software Handbook.

## REPAIR/ADVANCE REPLACEMENT POLICY

All repairs of ADC Products must be done by ADC or an authorized representative. Any attempt to repair or modify ADC Products without prior written authorization from ADC shall void ADC's warranty.

If a malfunction cannot be resolved by the normal troubleshooting procedures, call the BBG Technical Assistance Center at 1-800-366-3891, extension 3223 (in U.S.A. or Canada) or 612-946-3223 (outside U.S.A. and Canada). A telephone consultation can sometimes resolve a problem without the need to repair or replace the ADC Product.

If, during a telephone consultation, ADC determines the ADC Product requires repair, ADC will authorize the return of the affected Product by the issue of a Return Material Authorization number and complete return shipping instructions. If service is affected, ADC can arrange to ship a replacement Product when available from designated inventory. In all cases, the defective Product must be carefully packaged to eliminate damage, and returned to ADC in accordance with issued ADC instructions.

## REPAIR CHARGES

If the defect and the necessary repairs are covered by warranty, Buyer's only obligation is the payment of all transportation and associated costs in returning the defective Product to the location designated by ADC. ADC, at its option, will either repair or replace the Product at no charge and return the Product to Buyer with transportation costs paid by ADC, only



when ADC contracted carriers are used. Requested return of Product by any other means will be at Buyer's cost. Buyer is responsible for all other associated costs in return of Products from ADC. If Product is Out of Warranty or NTF (no trouble found), ADC will charge a percentage of the current Product list price. To obtain the percentage factor for Out of Warranty or NTF Product, contact the ADC Product Return Department at 1-800-366-3891, extension 3000 (in U.S.A. or Canada) or 612-946-3000 (outside U.S.A. and Canada).

If a service effecting advance replacement Product is requested, the current list price of a new Product will be charged initially. Customer purchase order is required to ship an advance replacement Product. Upon receipt of the defective Product, ADC will credit Buyer with twenty percent (20%) of Product list price charged for any returned Product found to be Out of Warranty, or one hundred percent (100%) credit for any In Warranty Product under the Program terms. Products must be returned within thirty (30) days to be eligible for any advance replacement credit. If repairs necessitate a field visit by an ADC representative, customer authorization (purchase order) must be obtained prior to dispatching a representative, ADC will charge the current price of a field visit plus round trip transportation charges from Minneapolis to the customer's site.

## REPLACEMENT/SPARE PRODUCTS

Replacement parts, including but not limited to button caps and lenses, lamps, fuses, and patch cords, are available from ADC on a special order basis. Contact the BBG Technical Assistance Center at 1-800-366-3891, extension 3223 (in U.S.A. or Canada) or 612-946-3223 (outside U.S.A. and Canada) for additional information.

Spare Products and accessories can be purchased from ADC. Contact Sales Administration at 1-800-366-3891, extension 3000 (in U.S.A. or Canada) or 612-946-3000 (outside U.S.A. and Canada) for a price quote and to place your order.

## RETURNED MATERIAL

Contact the ADC Product Return Department at 1-800-366-3891, extension 3000 (in U.S.A. or Canada) or 612-946-3000 (outside U.S.A. and Canada) to obtain a Return Material Authorization number prior to returning an ADC Product.

All returned Products must have a Return Material Authorization (RMA) number clearly marked on the outside of the package. The Return Material Authorization number is valid for thirty (30) days from authorization.

## SYSTEM INTEGRATION SERVICES

ADC offers the following system integration services. For calls originating in the U.S.A. or Canada, dial **1-800-366-3891, extension 3000**. For calls originating outside the U.S.A. or Canada, dial **612-946-3000**.

---

<b>Technical Assistance Center</b>	<ul style="list-style-type: none"> <li>• Product Management</li> <li>• Project Engineering</li> <li>• Project Administration</li> <li>• System Turn-Up and Test Support</li> <li>• Service/Maintenance Agreements</li> </ul>
<b>Technical Training</b>	<ul style="list-style-type: none"> <li>• Product Technology</li> <li>• Custom Designed Training</li> </ul>
<b>Technical Operations</b>	<ul style="list-style-type: none"> <li>• Detail Engineering</li> <li>• End-to-End Installation</li> <li>• Drafting Services</li> </ul>

---

## CUSTOMER SUPPORT SERVICES

ADC offers the following customer support services. For calls originating in the U.S.A. or Canada, dial **1-800-366-3891**, then request the extension listed. For calls originating outside the U.S.A. or Canada, dial **612-946-3000** or **612-946-3223**.

---

<b>BBG Technical Assistance Center Extension 3223</b>	<ul style="list-style-type: none"> <li>• Technical Information</li> <li>• System/Network Configuration</li> <li>• Product Specification</li> <li>• Product Application</li> <li>• Proposals</li> <li>• Training</li> <li>• Installation and Operation Assistance</li> <li>• Troubleshooting and Repair</li> <li>• Field Assistance</li> </ul>
<b>Sales Administration Extension 3000</b>	<ul style="list-style-type: none"> <li>• Quotation</li> <li>• Ordering</li> <li>• Delivery</li> <li>• General Product Information</li> </ul>
<b>Product Return Department Extension 3478</b>	<ul style="list-style-type: none"> <li>• ADC Return Authorization number and instructions must be obtained before returning products.</li> </ul>

---

Product information and service can also be obtained by writing ADC Telecommunications, Inc., P.O. Box 1101, Minneapolis, Minnesota 55440-1101, U.S.A.

Contents herein are current as of the date of publication. ADC reserves the right to change the contents without prior notice. **In no event shall ADC be liable for any damages resulting from loss of data, loss of use, or loss of profits and ADC further disclaims any and all liability for indirect, incidental, special, consequential or other similar damages. This disclaimer of liability applies to all products, publications and services during and after the warranty period.**

This publication may be verified at any time by contacting ADC's Technical Assistance Center at 1-800-366-3891, extension 3223 (in U.S.A. or Canada) or 612-946-3223 (outside U.S.A. and Canada), or by writing to ADC Telecommunications, Inc., Attn: Technical Assistance Center, Mail Station #77, P.O. Box 1101, Minneapolis, MN 55440-1101, U.S.A.



© 1998, ADC Telecommunications, Inc.  
All Rights Reserved  
Printed in U.S.A.

## Free Manuals Download Website

<http://myh66.com>

<http://usermanuals.us>

<http://www.somanuals.com>

<http://www.4manuals.cc>

<http://www.manual-lib.com>

<http://www.404manual.com>

<http://www.luxmanual.com>

<http://aubethermostatmanual.com>

Golf course search by state

<http://golfingnear.com>

Email search by domain

<http://emailbydomain.com>

Auto manuals search

<http://auto.somanuals.com>

TV manuals search

<http://tv.somanuals.com>