

Megabit Modem MM701G and MM702G User Manual

Version 2.1.12.x



Copyright

April 2003

© 2003 ADC DSL Systems, Inc. All Rights Reserved.

Information contained in this document is company private to ADC DSL Systems, Inc., and shall not be modified, used, copied, reproduced or disclosed in whole or in part without the written consent of ADC DSL Systems, Inc.

Trademark Information

ADC is a registered trademark of ADC Telecommunications, Inc. Megabit Modem is a registered trademark of ADC DSL Systems, Inc. No right, license, or interest to such trademarks is granted hereunder, and you agree that no such right, license, or interest shall be asserted by you with respect to such trademark.

Other product names mentioned in this documentation are used for identification purposes only and may be trademarks or registered trademarks of their respective companies.

Disclaimer of Liability

Contents herein are current as of the date of publication. ADC reserves the right to change the contents without prior notice. In no event shall ADC be liable for any damages resulting from loss of data, loss of use, or loss of profits, and ADC further disclaims any and all liability for indirect, incidental, special, consequential or other similar damages. This disclaimer of liability applies to all products, publications and services during and after the warranty period.

ABOUT THIS USER MANUAL

Use this manual to install, configure, and manage the ADC[®] Megabit Modem[®] MM701G and MM702G. These modems can be used in two types of applications:

- as an endpoint (CPE) to a DSLAM for Internet and other broadband connection through a service provider
- as a LAN extension by implementing a point-to-point connection with another modem of the same model (MM701G to MM701G or MM702G to MM702G)

To complete an endpoint installation for an MM701G or MM702G modem, follow the configuration instructions in all chapters of this manual, with the exception of Chapter 7, “Implementing a Point-to-Point LAN Extension.”

To complete a point-to-point installation for two MM701G or two MM702G modems, follow the configuration instructions in these chapters only:

- Chapter 1, “Installing the Modem”
- Chapter 2, “Accessing the Web Interface for Modem Management”
- Chapter 5, “Configuring System Parameters”
- Chapter 7, “Implementing a Point-to-Point LAN Extension”
- Chapter 8, “Configuring Modem Security”

After configuring the modem(s) for your application, monitor its status and perform other management functions using the instructions in [Chapter 9, “Managing the Modem.”](#) If you choose to manage the modem through the console port, use the instructions in [Appendix A, “Accessing the Command-Line Interface.”](#)

DOCUMENT CONVENTIONS



Notes contain information about special circumstances.



Cautions indicate the possibility of personal injury or equipment damage.

The following convention is used to identify the sequence of Web pages and/or menus you navigate to access the feature configuration.

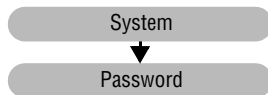

The top grey bar indicates that the configuration parameter is accessed from menu bar on the **System Status** page. For example, select **System** on the menu bar, then select **Password** from the **System Options** menu. The Web page from which you can change the username and password is then displayed.

FCC CLASS B COMPLIANCE

This equipment has been tested and found to comply with the limits for a Class B digital device, pursuant to part 15 of the FCC Rules. These limits are designed to provide reasonable protection against harmful interference in a residential installation. This equipment generates, uses and can radiate radio frequency energy and, if not installed and used in accordance with the instructions, may cause harmful interference to radio communications. However, there is no guarantee that interference will not occur in a particular installation.

If this equipment does cause harmful interference to radio or television reception, which can be determined by turning the equipment off and on, the user is encouraged to try to correct the interference by one or more of the following measures:

- Reorient or relocate the receiving antenna.
- Increase the separation between the equipment and receiver.
- Connect the equipment into an outlet on a circuit different from that to which the receiver is connected.
- Consult the dealer or an experienced radio/TV technician for help.

TABLE OF CONTENTS

Chapter 1: Installing the Modem	1
Unpack the Modem	1
Determine What You Need	2
Attach Feet to the Modem	2
Connect Cables	3
Connect the 10Base-T Port	3
LED Status Indications	5
Chapter 2: Accessing the Web Interface for Modem Management.....	7
Assign IP Addresses	7
Set Up the Web Browser	9
Accessing the Modem Web Pages	11
Chapter 3: Configuring the LAN	13
Before You Begin.	13
Configure the LAN.....	14
Configure DNS Relay Mode	16
Configure DHCP Server Mode	18
Configure the Ethernet Port Mode	23
Chapter 4: Configuring the WAN.....	25
Before You Begin.	25
Configure a New WAN Session.....	26
Set Up an RFC 1483 Bridged Session	27
Set Up an RFC 1483 Routed Session.....	29
Set Up a PPPoA or PPPoE Routed Session	32
Permanently Save Sessions	35
Edit a WAN Session.....	36

Chapter 5: Configuring System Parameters	39
Before You Begin.	39
Assigning User Access	40
Add a Default Gateway.....	44
Add Static Route Entries.....	45
Add SNMP Communities	48
Change Spanning Tree Setting	51
Saving Changes.....	53
Rebooting the Modem	55
Chapter 6: Configuring DSL Parameters.....	57
Before You Begin.	57
Complete a G.shdsl Quick Configuration.....	58
Complete a DSL Advanced Configuration.....	60
Chapter 7: Implementing a Point-to-Point LAN Extension.....	63
Before You Begin.	63
Complete a Quick Installation	64
Configure for Central-Office Mode	64
Change the LAN IP Address for the Central-Office Modem.....	65
Complete a Custom Configuration	66
Configure the Remote Modem	66
Configure the Central-Office Modem	70
Verify Connectivity	76
Chapter 8: Configuring Modem Security.....	77
Before You Begin.	77
Configure NAT	78

Chapter 9: Managing the Modem	81
View System Status	82
View Modem Status	82
View System Log	84
View WAN Statistics	85
View LAN Statistics	87
View SmartCNCT Security Statistics	89
View ATM Statistics	90
View DSL Statistics	92
View G.shdsl Link Statistics	92
View G.shdsl Error Counters	94
Manage Software and Configuration	96
Update System Software	96
Reset to Factory Defaults	98
Appendix A: Accessing the Command-Line Interface	99
Connect to the Console Port	100
Access the Command-Line Interface	100
Access through the Console Port	101
Access through a Telnet Session	103
Set Up the LAN	104
Manage WAN Sessions	106
Add a New Session	107
Permanently Save Sessions	116
Edit an Existing Session	117
Manage DSL	118
Configure G.shdsl Parameters	119
View G.shdsl Configuration	124
Monitor G.shdsl Statistics	125
Restoring Factory Defaults	130

Saving the Current Configuration.....	131
Updating System Software	132
Viewing System Information.....	133
Rebooting the Modem	134
Appendix B: Specifications	135
Overview.....	136
Data Specifications	137
VLAN Support	137
DSL Standards.....	137
ATM standards	137
Internetworking Features.....	137
WAN Protocols	138
Security.....	138
Management	138
Software Upgrade.....	138
Encapsulation	139
RFCs.....	139
MIBs.....	140
Default Session Parameter Values	140
Hardware Specifications	141
LED	141
Connectors.....	141
LAN Interface.....	141
WAN Interface	142
Connector Pinouts	143
Rate vs. Reach.....	145
Appendix C: Contacting ADC	147
Appendix D: Glossary.....	149
Index.....	155

INSTALLING THE MODEM

The MM701G and MM702G are versatile, high-speed modems that connect an Ethernet LAN to one or more service providers using G.shdsl transmission technology. The connections provide instant and high-speed broadband access to the Internet or to other types of Wide Area Networks (WANs). The MM701G and MM702G provide:

- configuration either as a point-to-point LAN extension or as an end-connection to a DSLAM (see page iii for the process you must follow to complete either installation)
- larger packet sizes to accommodate VLAN traffic
- 32 simultaneous Bridge/Router or PPP sessions to the same or different service providers over the WAN interface
- protocols and services such as DHCP server, DNS Relay, NAT, and RIP
- capability to download pre-defined configuration files to the modem flash memory instead of manually defining each and every value for a modem

STEP 1—UNPACK THE MODEM

If you store the modem for a long period of time, use the original antistatic bag and packaging. Observe environmental specifications provided in Appendix B.

- 1 Remove the modem from the packaging.
- 2 Visually inspect the container for signs of damage. If the equipment was damaged in transit, report the damage to the transportation company and to the sales representative.
- 3 Check the contents of the package for:
 - 6 Vdc power supply with cord
 - black Cat. 5 cable for Ethernet connection
 - silver cord for DSL connection
 - flat cable (gray) and DB-9 port adapter for console port connection

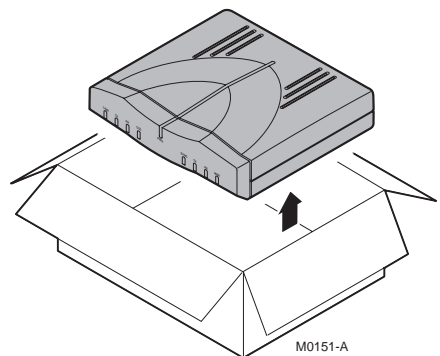

STEP 2—DETERMINE WHAT YOU NEED

In addition to what is shipped with the modem, you need the following hardware and software to complete the installation and configuration.

Equipment:	Requirement:
PC	<p><i>Hardware:</i></p> <ul style="list-style-type: none">• Ethernet NIC Card (10 Mbps) installed in each PC and other network equipment that will be connected to the LAN. Verify if the NIC in the device which directly connects to the modem LAN port is half- or full-duplex. The modem LAN port must be set to the same transmission direction(s) as the NIC.• Optional—serial interface card installed in PC (used for access to the modem console port). <p><i>Software:</i></p> <ul style="list-style-type: none">• TCP/IP protocol stack installed (see the operating system documentation for information).• Terminal emulation program (such as HyperTerminal) installed for access to the command line interface, through the console port (see the operating system documentation for information).• Web browser installed such as Internet Explorer® Version 4.0 (or higher).• Operating System CD-ROM (Win98, Win98SE, Win2000, WinME, or WinXP).
Ethernet hub, switch, or router	Optional—use either a hub, switch, or a router to connect multiple PCs or other LAN equipment to the modem Ethernet 10Base-T port (LAN port).

STEP 3—ATTACH FEET TO THE MODEM

Attach oval rubber feet to the modem to prevent it from slipping on surfaces (a desktop, for example) and from scratching those surfaces. Do the following:

- 1 Remove the paper from the adhesive back of the oval rubber feet.
- 2 Attach each of the four oval rubber adhesive-backed feet to a footprint recess on the bottom of the modem.

STEP 4—CONNECT CABLES

Install cables for the Ethernet port (“[Connect the 10Base-T Port](#)” below). Then check LED status on [page 5](#).

Connect the 10Base-T Port

Set the modem MDI/MDI-X switch for the 10Base-T port to allow the modem to connect directly to other network devices such as a PC, hub, switch, or router.

- 1 Set the modem MDI/MDI-X switch to one of the following:
 - MDI-X when connecting to a device such as a PC Ethernet NIC card that has an MDI port
 - MDI when connecting to a device such as a hub, switch, or router that have MDI-X ports

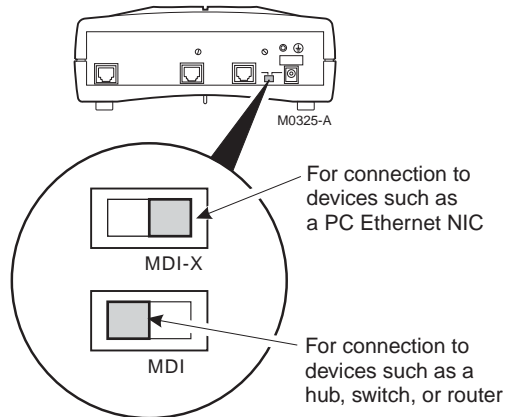

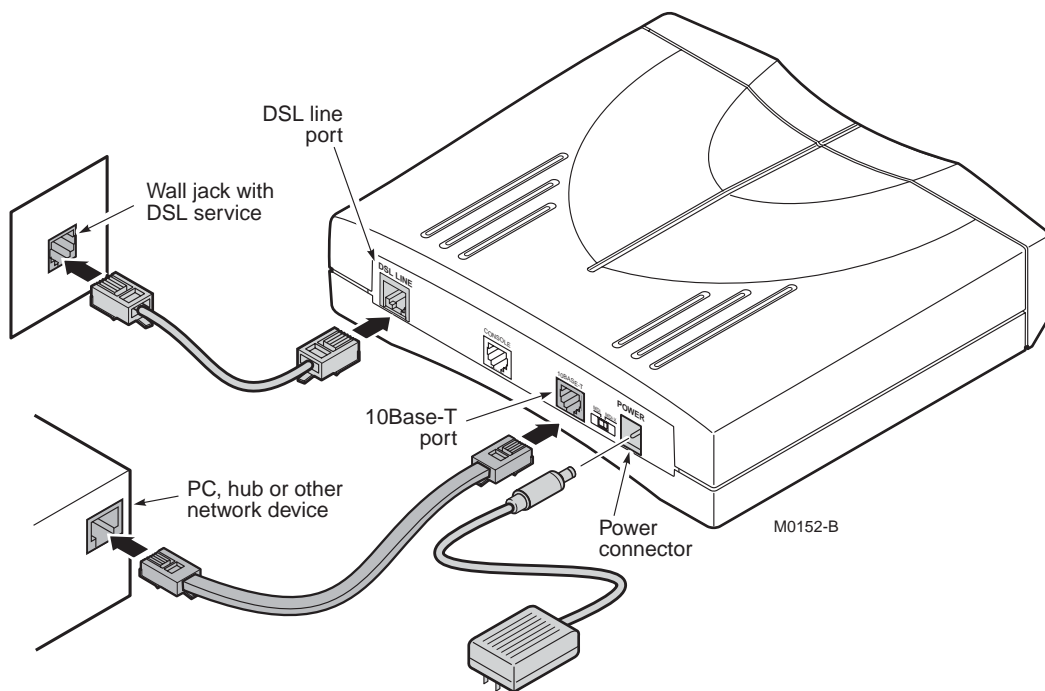

Ensure that the NIC in the PC and the modem LAN port are both set to either half- or full-duplex for the transmission direction(s). If you need to change the modem LAN port setting to match the NIC, follow the procedures in **“Manage DSL”** on page 118 (half-duplex is the default).

- 2 Connect the cables to the modem rear panel as shown above:
 - silver cable to the DSL line port and wall jack
 - black Ethernet cable to the 10Base-T port and to another Ethernet device such as a PC, hub, or router
 - power cable to the modem power connector and to facility power
- 3 Refer to **“LED Status Indications”** on page 5, to check modem LED status indications.

LED Status Indications

The following indicates the operational status provided by front panel LEDs.

LED	State	Description
PWR	On green	Modem has power.
	Off	Modem does not have power.
LAN		
LINK	On green	A PC, hub, or other network device is connected to the modem 10Base-T interface.
	Off	No device is connected to the modem 10Base-T interface.
TX	Flashing green	Modem is transmitting data to devices on the LAN.
	Off	Modem is not transmitting data to the LAN.
RX	Flashing green	Modem is receiving data from devices on the LAN.
	Off	Modem is not receiving data from the LAN.
COL	Flashing green	Ethernet packet collisions are occurring.
	Off	No Ethernet packet collisions are occurring.
DSL		
The service provider sets up the DSL parameters for your service. The modem must have the DSL SYNC LED lit before you can connect sessions.		
SYNC	On green	DSL transceiver is synchronized (connected) and in normal operation mode.
	Flashing green	Slow flashing green indicates that the DSL transceiver is in a start-up or handshaking sequence. Fast flashing green indicates that the DSL transceiver is in training sequence.
	Off	Power is not connected.
TX	Flashing green	Modem is transmitting data over the DSL connection.
	Off	Modem is not transmitting data over the DSL connection.
RX	Flashing green	Modem is receiving data over the DSL connection.
	Off	Modem is not receiving data over the DSL connection.
MAR	On green	Local SNR Margin is greater than the SNR Margin Limit.
	Off	Local SNR Margin is less than the SNR Margin Limit.

ACCESSING THE WEB INTERFACE FOR MODEM MANAGEMENT

2

Use the Web interface as the most comprehensive and convenient way to set up and manage the modem. This chapter provides steps to help you access the Web interface pages for configuration and management of the modem.

Access to the command-line interface is available through the modem console port or over a network using a telnet session. Not all configuration and management features, however, are supported through the command-line interface. See [Appendix A, “Accessing the Command-Line Interface”](#) on page 99 for instruction on using the command-line interface for configuration and management.

STEP 1—ASSIGN IP ADDRESSES

To access the modem Web interface, the management PC must be on the same LAN IP subnet as the modem. Default values are shown to the right. Do one of the following:

- Change the management PC IP address so that it is on the same subnet as the modem (go to [page 8](#) and begin with [Step 1](#)).
- Change the IP address of the modem 10Base-T (LAN) port to a value assigned by your network administrator using the command-line interface (go to “[Set Up the LAN](#)” on [page 104](#)).

Modem Defaults	
Subnet	10.0.0.0
Subnet Mask	255.255.255.0
IP Address	10.0.0.1

Use the following steps to set up a management PC to be on the same subnet with the modem. (The example shows instructions for a PC that is running Microsoft Windows 98 SE; instructions for other operating systems may differ slightly.)

- 1 From the Windows desktop, click **Start, Settings, Control Panel** to open the **Control Panel** dialog.
- 2 From the **Control Panel** dialog, double-click the **Network** icon (shown to the right). The **Network** dialog is displayed.
- 3 From the **Configuration** tab, double-click **TCP/IP** to display the **TCP/IP Properties** dialog.

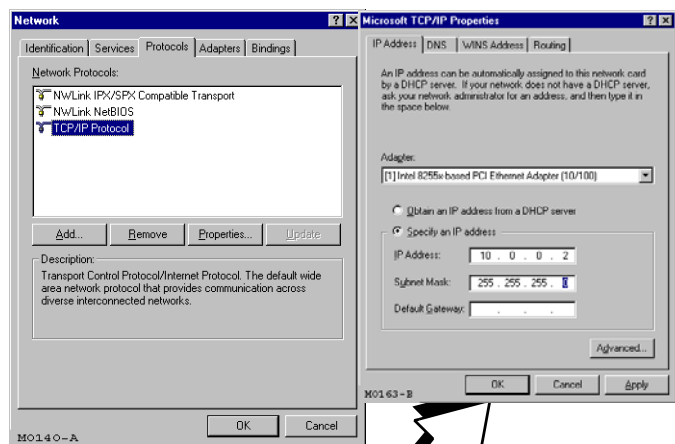

TCP/IP Network Configuration
for an Ethernet NIC

- 4 The modem can be set up to serve IP addresses to devices on the LAN (DHCP server feature). Do one of the following:
 - If DHCP server has not been enabled on the modem (default setting), select **Specify an IP address**.
 - If DHCP server has been enabled on the modem, select **Obtain an IP address automatically** and go to **Step 6**.
- 5 Enter an **IP Address** and **Subnet Mask** that places the management PC on the same subnet as the modem. Use an IP address in the range of 10.0.0.2 to 10.0.0.254.
- 6 Click **OK** to close the **TCP/IP Properties** dialog.
- 7 Click **OK** to close the **Network** dialog.
- 8 Click **OK** to restart the computer.

STEP 2—SET UP THE WEB BROWSER

To access and view the modem Web pages, set up features for the Web browser. The Web browser must have cache settings enabled to allow the Web browser to compare its cached Web page against the modem Web page every time it is accessed, providing current information. Also, it is preferable to disable proxies. (The example below shows setup for the Internet Explorer Web browser; instructions for other Web browsers may differ slightly.)

- 1 Open the Web browser.
- 2 On the menu bar, click **Tools, Internet Options** to open the **Internet Options** dialog.

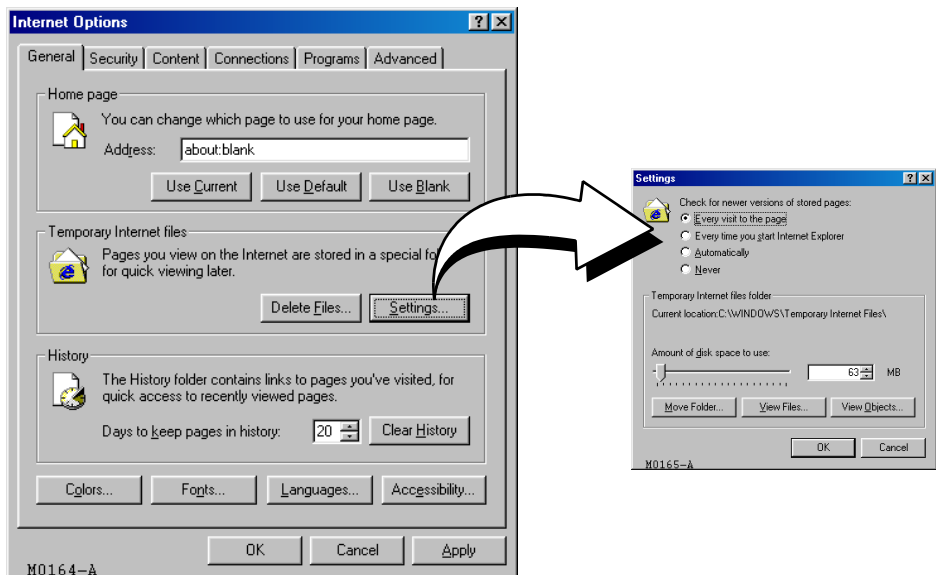

- 3 In the **Temporary Internet Files** section of the dialog, click **Settings**.
- 4 Select **Every visit to the page**, then click **OK**. (This sets enables cache settings.)

- 5 Click the **Connections** tab, then click **LAN Settings** to open the **LAN Settings** dialog.

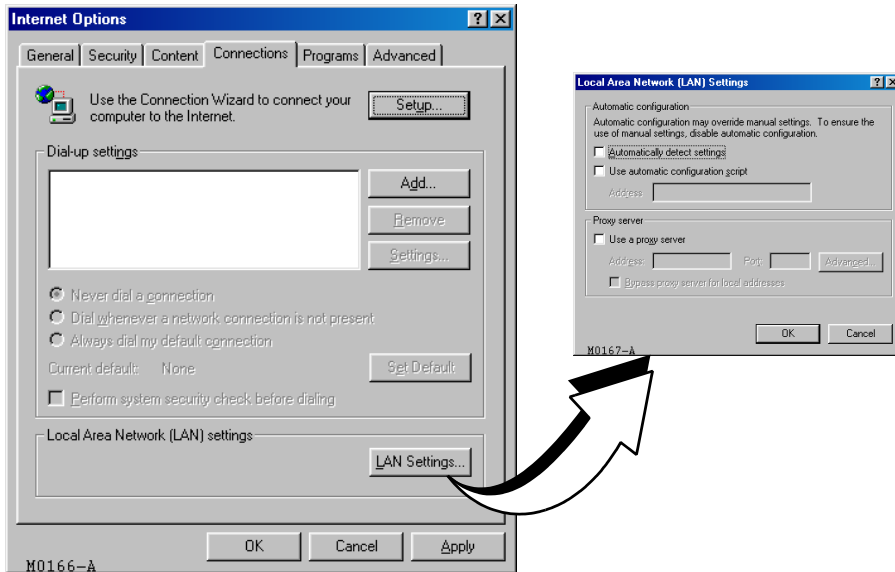

- 6 In the **Proxy Server** section of the dialog, do one of the following:
 - If the management PC is not connected to an intranet and is connected only to the modem, clear the **Use a proxy server** box.
 - If the management PC is connected to the modem and also connected to an intranet (with an assigned proxy server) using a hub, do the following:
 - select the **Use a proxy server** box
 - click **Advanced**, then add the IP address of the modem (default is 10.0.0.1) to the **Exceptions** field.
- 7 Click **OK** to close the **LAN Settings** dialog.
- 8 Click **OK** to close the **Internet Options** dialog.

STEP 3—ACCESSING THE MODEM WEB PAGES

Use the following steps to access the login page, enter the Web interface, and navigate the Web pages. This login is for the system administrator responsible for configuring and managing the modem.

- 1 Do one of the following to access the modem Web pages:
 - If you did not change the modem 10Base-T port IP address (page 7), type **http://10.0.0.1** in the Location Bar field of the Web browser (shown below), then press **ENTER**.

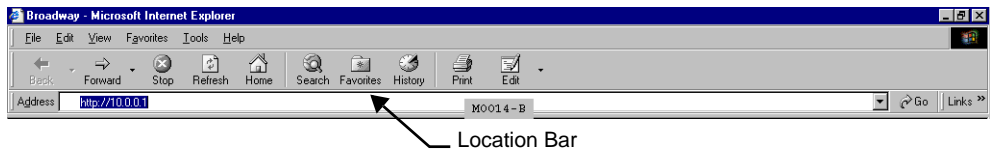

- If you changed the modem 10Base-T port IP address (page 7), type **http://** and the new IP address in the Location Bar field of the Web browser, then press **ENTER**.
- 2 Enter the **User Name** and **Password**, then click **OK**.

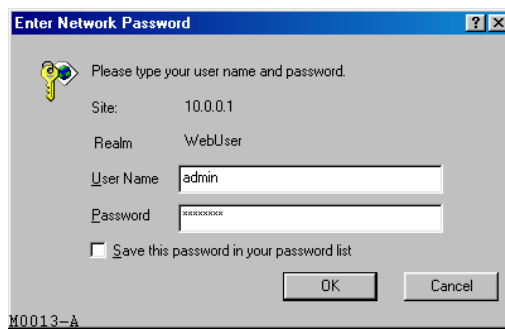

<i>Login Defaults</i>	
Username:	admin
Password:	password

The **System Status** page is displayed and functions as a home page with a menu bar. This menu bar provides navigation to all Web pages used for configuration and management.

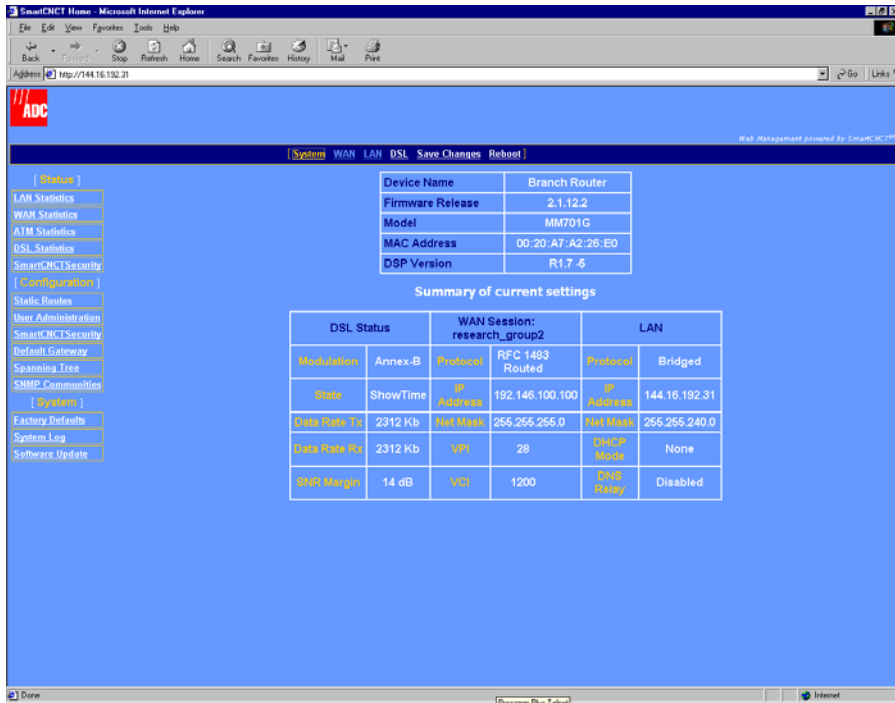

Additionally, the **System Status** page provides a status of the current modem configuration. See “View System Status” in Chapter 9, “Managing the Modem” for more information about this **System Status** page.

CONFIGURING THE LAN

3

The LAN configuration sets up the interface between the modem 10Base-T LAN port and devices on the LAN. The LAN is managed by your network administrator, who will make the decisions concerning its topology.

For instructions on setting up the LAN interface for a point-to-point modem application, go to Chapter 7, “Implementing a Point-to-Point LAN Extension.”

BEFORE YOU BEGIN. . .

Your network administrator will:

- Determine if you will use the modem Ethernet port in full- or half-duplex mode.
- Identify a subnet value, including IP addresses and subnet masks.
- Determine if DHCP for the modem is enabled. If it is enabled, determine if the modem will be configured as a:
 - DHCP client which receives an IP address from another device that is a DHCP server on the LAN
 - DHCP server (determine the range of IP addresses the modem will need to serve, and identify the DHCP gateway and DNS server)
 - DHCP relay agent (determine the IP address to which the DHCP functions will be relayed)
- Determine if DNS Relay mode for the modem is enabled. If it is, identify the IP address for the DNS server.

CONFIGURE THE LAN

From the **LAN Configuration** page, configure the parameters for the LAN as indicated by your system administrator. The default protocol for the LAN port is bridged.

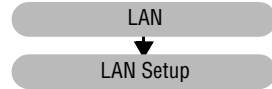

- 1 Select **LAN** on the menu bar, then select **LAN Setup** under **[LAN Options]** to access the **LAN Configuration** page.

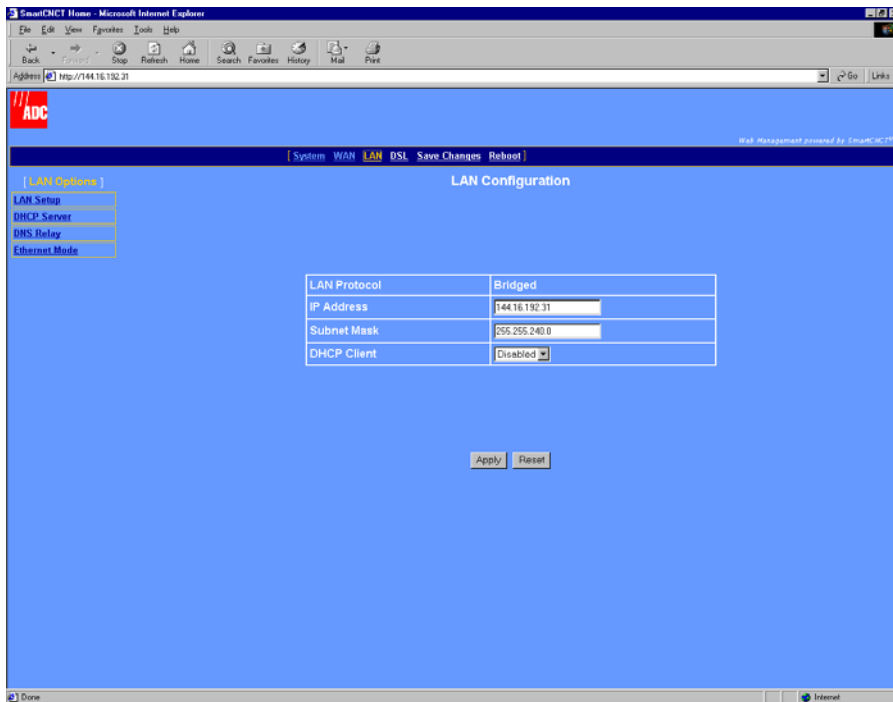

- 2 Configure the following parameters:

LAN Protocol

The LAN protocol is set to bridged and cannot be changed through the Web interface. If you want to change the protocol to routed, use the command-line interface (go to “Set Up the LAN” on page 104).

IP Address

See the LAN administrator for a LAN IP address. Do one of the following:

- Enter an IP address for the LAN (10Base-T) port provided by the LAN administrator
- Use the default IP address for the LAN port which is 10.0.0.1. If you choose to use the default IP address, ensure that the devices on your LAN are on the same subnet as this modem LAN port.
- If you want a DHCP server on your LAN to automatically provide the modem LAN port IP address, select **Client** for the DHCP configuration (see DHCP Client below).

Subnet Mask

See the LAN administrator for the subnet mask. Do one of the following:

- Enter the subnet mask for the LAN (10Base-T) port provided by the LAN administrator.
- Use the default subnet mask for the LAN port which is 255.255.255.0. If you choose to use the default subnet mask, ensure that it allows devices on your LAN to access the modem LAN port.
- If you want a DHCP server on your LAN to automatically provide the subnet mask in addition to the IP address, select **Client** for the DHCP configuration (see DHCP Client below).

DHCP Client



If a DHCP server is not set up and active on your LAN, do not enable DHCP client. DHCP Client mode is recommended for use only when bridging is used as the LAN protocol.

A DHCP server must be set up and active on the LAN prior to enabling this feature. When DHCP Client is **Enabled**, the modem automatically changes the LAN port IP address to all zeroes so that the DHCP server on the LAN can immediately serve it an IP address. This parameter is used when the LAN port is in bridging mode only.

CONFIGURE DNS RELAY MODE

The DNS resolver on a DNS server maps human-readable addresses to IP address numbers. A human-readable address is one such as:

maggie.copro.company.com

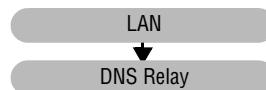

As a DNS relay, the modem forwards requests for DNS resolution to another device on the LAN or WAN that performs the resolution service. When you enable DNS Relay mode, enter the IP address for the device that will perform DNS resolution. Either your service provider or LAN administrator will provide this IP address.

If the modem is configured as a DHCP client (see “Configure the LAN” on page 14), it is served a DNS address in addition to an IP address and subnet mask. The DNS relay will be automatically enabled and the DNS server IP address will be automatically displayed in the DNS server IP address field shown on page 17.

If you do not enable DNS relay nor do you enable DHCP client, then you must add the IP address for a DNS resolver to the Internet Protocol (TCP/IP) setup for your PC (or other DHCP client). See page 19 for more information on setting up this information.

- 1 Select **LAN** on the menu bar, then select **DNS Relay** under **(LAN Options]** to access the **DNS Relay mode** page.





If DHCP Client is selected (see “Configure the LAN” on page 14) and a DNS server IP address assigned, then DNS: Enable Relay is automatically enabled and the DNS server IP address automatically displayed in that field.

- 2 Select **Enabled**, then click **Configure** to access the following **DNS: Enable Relay** page.

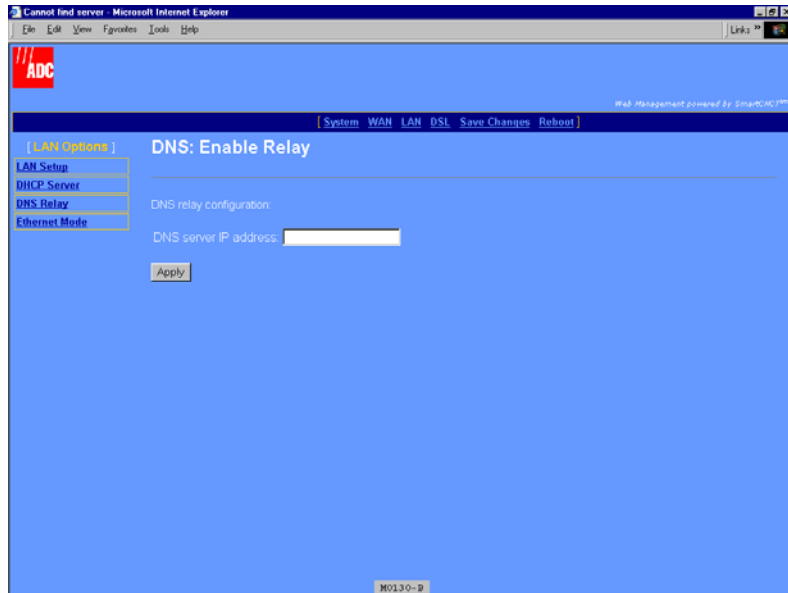

- 3 Enter the **DNS server IP address** for the device to which the modem will forward IP address resolution requests.
- 4 Click **Apply**.

CONFIGURE DHCP SERVER MODE

From the **DHCP server mode** page, configure the parameters for the modem to function as a DHCP server by either directly serving IP addresses (DHCP server) or forwarding the request to another device that will provide DHCP services (DHCP relay agent). If you selected DHCP client when you configured LAN parameters (page 15), then **DHCP server mode** is automatically set to **Disabled**.

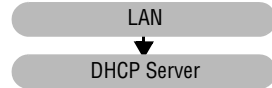

- 1 Select **LAN** on the menu bar, then select **DHCP Server** under **[LAN Options]** to access the **DHCP server mode** page.



- 2 Select one of the following three DHCP server modes as indicated by your LAN administrator, then click **Configure**:
- **Disabled—DHCP server mode** is not enabled. If you do not enable DHCP server for the modem, you must enter a default gateway for each client on your LAN (such as PCs) and also an IP address for a DNS server. Either the service provider or your LAN administrator will provide you these IP addresses to enter in the Internet Protocol (TCP/IP) setup for your PC (or other LAN clients). See “Assign IP Addresses” on page 7 for information about how to access this dialog. The following is an example of the dialog and fields that must be filled in (example is from Windows 2000; the dialog for other operating systems may be slightly different).

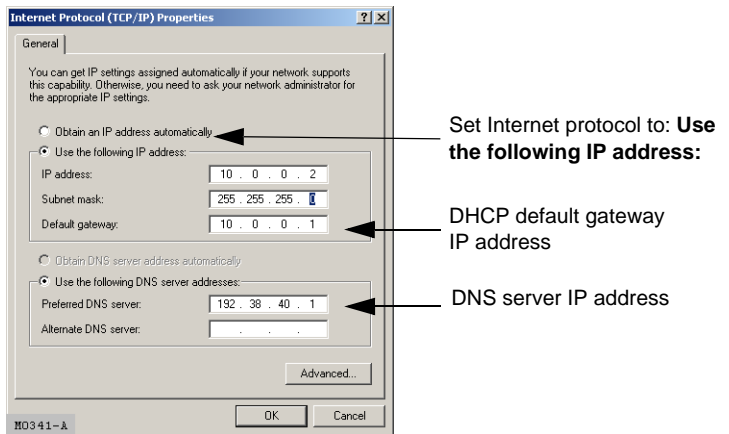

- **Enabled**—The modem functions as a DHCP server and can serve IP addresses, a DHCP gateway, and a DNS server IP address to devices on your LAN. When the modem DHCP server is enabled, then LAN clients (such as PCs) must have their Internet protocol (TCP/IP) set to **Obtain an IP address automatically** (see page 19 for an example of where to select this option).
 - a Select **Enabled**, then click **Configure** to access the following **DHCP Server** page (DHCP Server cannot be enabled when the LAN protocol is in bridge mode).



- b Configure the following parameters when DHCP server is enabled for the modem:

DHCP Range Low

The lowest IP address value that the modem can serve when configured as a **DHCP Server**. A maximum of 20 IP addresses can be served by the modem. This IP address value is provided by your LAN administrator and must be on the same subnet as the modem LAN port.

DHCP Range High

The highest IP address value that the modem can serve when configured as a **DHCP Server**. A maximum of 20 IP addresses can be served by the modem. This IP address value is provided by your LAN administrator and must be on the same subnet as the modem LAN port.

Default Lease Time

The default amount of time, in seconds, that a device on the LAN can be bound to the IP address it was served before the lease expires. This value is provided by your LAN administrator.

Max Lease Time

The maximum amount of time, in seconds, that a device on the LAN can be bound to the IP address it was served before the lease expires. This value is provided by your LAN administrator.

DHCP Default Gateway

Enter the IP address of the DHCP default gateway that is provided by the LAN administrator for devices on the LAN. After you configure this IP address, the modem provides this IP address as a default DHCP gateway to requesting DHCP clients (such as PCs) on the LAN. If there are no gateways on the LAN, then the modem LAN port IP address can be assigned as the gateway.

DHCP DNS Server

Enter the IP address of the Domain Name System (DNS) server that will translate human-readable addresses to IP addresses. The DNS server can be either on the LAN or the WAN side of the modem. The modem provides this IP address as a default DNS server to requesting DHCP clients (such as PCs) on the LAN. If the DNS server is on the LAN side of the modem, acquire the IP address from your LAN administrator. If the DNS server is on the WAN side of the server, acquire the IP address from the service provider.

If you enabled DNS relay on [page 16](#) and entered a DNS server IP address, then enter the modem LAN port IP address as the DHCP DNS server.

- **DHCP relay agent**— The modem forwards the request for an IP address, DHCP default gateway, and DNS server IP address to a device acting as a DHCP server. The DHCP server can be either on the LAN or the WAN side of the modem. If on the LAN side, acquire the IP address from your LAN administrator. If on the WAN side, acquire the IP address from the service provider.
 - a Select **DHCP relay agent**, then click **Configure** to access the following **DHCP Server** page.

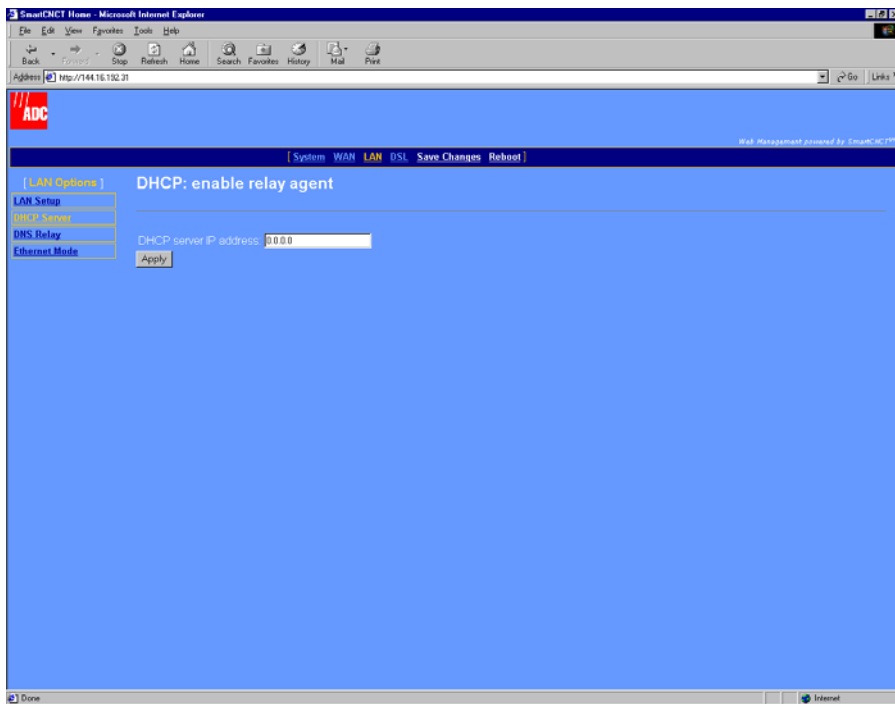

- b Enter the **DHCP Server IP address** for the device to which the modem will forward DHCP services requests, then click **Apply**.

CONFIGURE THE ETHERNET PORT MODE

The modem LAN (Ethernet) port must be set the same half- or full-duplex mode as the NIC (or other Ethernet equipment) that connects directly to it for management. Determine the mode to which your NIC (or other Ethernet equipment) is set, then configure the same mode for the modem LAN port.

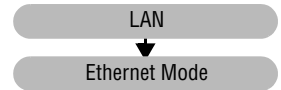

- 1 Select **LAN** on the menu bar, then select **Ethernet Mode** under **LAN Options]** to access the **Ethernet Mode** page.

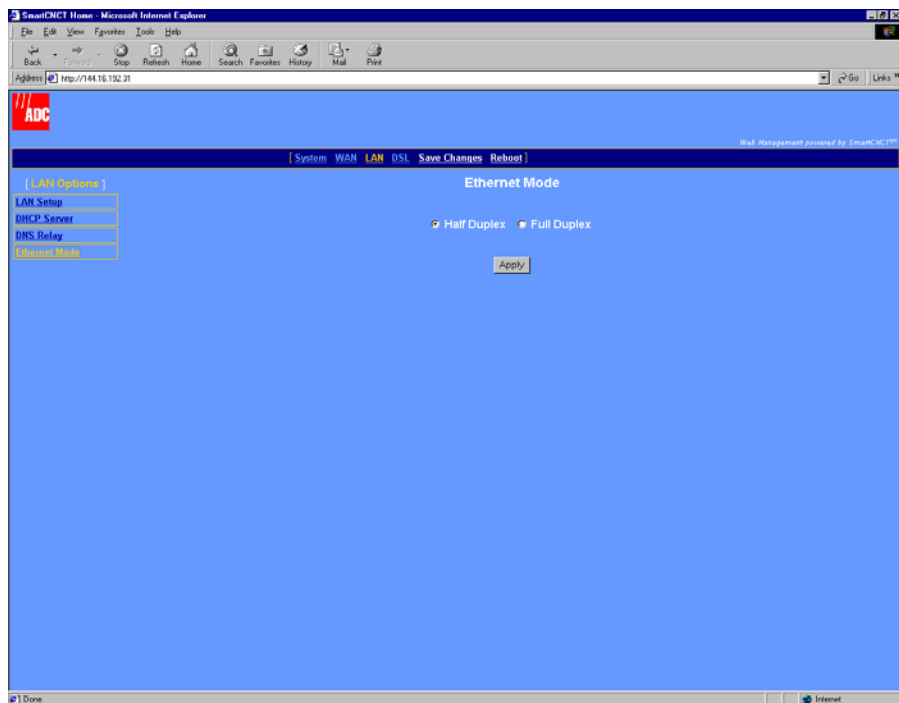

- 2 Select either **Half Duplex** or **Full Duplex**.

CONFIGURING THE WAN

4

The WAN configuration sets up from 1 to 32 sessions between the modem and the service provider or between two G.shdsl modems (see Chapter 7, “Implementing a Point-to-Point LAN Extension” for more information). Each session can be configured separately, specifying the protocol, IP address, ATM connection identifier, ATM QoS, and more.

BEFORE YOU BEGIN. . .

The following should be supplied by the service provider before configuring WAN sessions:

- Protocol for each session, where the choices are the following for a maximum of 32:
 - RFC 1483-Bridge (up to 8 sessions)
 - RFC 1483-Router (up to 16 sessions)
 - PPPoA or PPPoE (up to 8 sessions for either type)
- IP address and subnet mask for each session using RFC 1483-Router protocol.
- RIP version (each direction) for each session using RFC 1483-Router protocol or PPP:
 - RIP Version 1
 - RIP Version 2
 - RIP Version 1 and RIP Version 2
- Encapsulation for 1483-Bridge or 1483-Router, where the choices are:
 - LLC
 - VCMux
- Login and authentication for each session using PPP protocol, where the choices are:
 - login name and password
 - authentication type of either PAP or CHAP
- ATM parameters for each session, including:
 - VPI and VCI values
 - Quality of Service (QoS) which could be UBR, CBR, or VBR-nrt, and VBR-rt, and applicable cell rates

CONFIGURE A NEW WAN SESSION

You can configure up to 32 total PPPoA, PPPoE, 1483-Bridge, and 1483-Router sessions for the modem. See [page 25](#) for the maximum number of sessions per each protocol type that can be set up. A default bridging session is set up. From the WAN configuration page, define the parameters for each session.

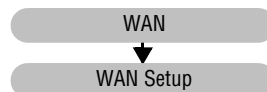

- 1 Select **WAN** on the menu bar to access the **WAN Configuration** page.

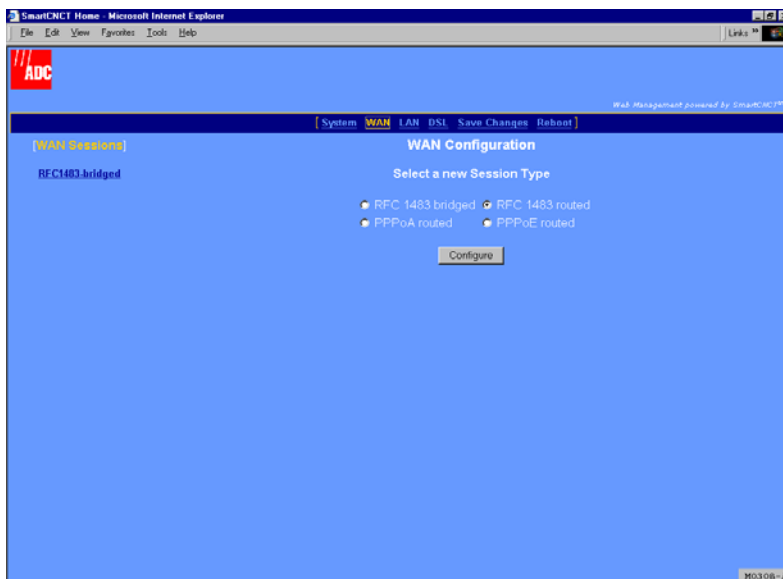

- 2 To add a new session, choose one of the following protocols from **Select a new session type**.
 - **RFC 1483 bridged** if the modem forwards packets based on MAC addresses. You can enable Spanning Tree when you select Bridge sessions. See [“Change Spanning Tree Setting”](#) on [page 51](#).
 - **RFC 1483 routed** if the modem routes packets based on IP addresses.
 - **PPPoA routed** if the modem establishes PPP sessions over ATM with the service provider and routes packets based on IP addresses.
 - **PPPoE routed** if modem establishes PPP sessions over Ethernet with the service provider and routes packets based on IP addresses.
- 3 Click **Configure** to access the session page for the protocol type you selected.
- 4 Go to the appropriate section that follows for the protocol that you selected.

Set Up an RFC 1483 Bridged Session

You selected **RFC 1483 bridged** from the **WAN Configuration** page to display the following page.

The screenshot shows a web browser window displaying the SmartCNC1 WAN Configuration page. The page title is "RFC1483 Bridged Session". The navigation menu includes "System", "WAN", "LAN", "DSL", "Save Changes", and "Reboot". The "WAN Sessions" section is active, showing a list of sessions: "Research_sector" and "PPPoA.ROUTED". The main configuration area contains the following fields:

Session Name	<input type="text" value="bridging_only"/>
Virtual Path ID (VPI 0 - 4,095)	<input type="text" value="0"/>
Virtual Channel ID (VCI 32 - 65,535)	<input type="text" value="32"/>
ATM QoS	<input type="text" value="UBR"/>
QoS Peak Cell Rate	<input type="text" value="2000"/>
QoS Sustainable Cell Rate	<input type="text" value="0"/>
QoS Maximum Burst Size	<input type="text" value="0"/>
Encapsulation	<input type="text" value="LlcBridged"/>

Below the form is a "Create" button. The browser status bar shows "Done" and "100-4.9-A".

1 Configure the following parameters for each session:

Session Name

Enter a unique, descriptive identifier for the session. This name can have a maximum of 32 characters.

Virtual Path ID (VPI)

Enter the value (from 0 to 4,095) provided by the service provider. The number identifies the virtual path that transports ATM cells between the modem and the service provider. This value must match the virtual path identification (VPI) value the service provider uses for this connection.

Virtual Channel ID (VCI)

Enter the value (from 32 to 65,535) provided by the service provider. The number identifies the virtual channel for this session that transports ATM cells between the modem and the service provider. This value must match the virtual channel identification (VCI) value the service provider uses for this connection.

ATM QoS

Select the ATM Quality of Service indicated by your service provider. The options are:

- UBR (unspecified bit rate is the default setting)
- CBR (constant bit rate)
- VBR-rt (variable bit rate real-time)
- VBR-nrt (variable bit rate non-real-time)

QoS Peak Cell Rate

Enter the QoS Peak Cell Rate (PCR) value supplied by your service provider. If you are not provided a PCR value, use the default. PCR is the maximum rate at which data is transferred on the line and measured in ATM cells per second. The valid range is 1-5500 cells per second. The default PCR is 5500.

QoS Sustainable Cell Rate

Enter the QoS Sustainable Cell Rate (SCR) value supplied by your service provider. Use for VBR-rt, and VBR-nrt ATM QoS. SCR is the average rate at which ATM cells are transferred, measured in cells per second. The SCR must be less than the PCR. The valid range is 1-5500 cells per second.

QoS Maximum Burst Size

Enter the QoS Maximum Burst Size (MBS) value supplied by your service provider. Use with VBR-rt and VBR-nrt QoS. MBS is the maximum number of cells that can be transmitted at the peak cell rate. The MBS rate must be equal to or less than the PCR. The default MBS is 0.

Encapsulation

Select the encapsulation type as indicated by the service provider. The options are:

- **LlcBridged**—Logical Link Control allows multiple protocols to be run over the session. This is the default encapsulation.
- **VcMuxBridged**—Virtual Channel Multiplexer-based encapsulation allows one protocol to be run over the session.

- 2 Click **Create** to add the new RFC1483-Bridge session to your session list on the **WAN Configuration** page.

Set Up an RFC 1483 Routed Session

You selected **RFC 1483 routed** from the **WAN Configuration** page to display the following page.

The screenshot shows a web browser window displaying the SmartCNC1 configuration interface. The page title is "RFC1483 Routed Session". The configuration parameters are as follows:

Session Name	research_session
Virtual Path ID (VPI 0 - 4,095)	0
Virtual Channel ID (VCI 32 - 65,535)	1024
ATM QoS	UBR
QoS Peak Cell Rate	5000
QoS Sustainable Cell Rate	0
QoS Maximum Burst Size	0
Encapsulation	LlcRouted
DHCP Client	<input checked="" type="checkbox"/> Enabled
IP address	192.10.0.102
Subnet Mask	255.255.255.0
Rip Send	<input checked="" type="checkbox"/> Ver 1 <input type="checkbox"/> Ver 2 (M-cast) <input checked="" type="checkbox"/> Ver 2 (B-cast)
Rip Accept	<input checked="" type="checkbox"/> Ver 1 <input checked="" type="checkbox"/> Ver 2

At the bottom of the form is a "Create" button. The browser's address bar shows "SmartCNC1 Home" and the page is titled "RFC1483 Routed Session".

- 1 Configure the following parameters for each session:

Session Name

Enter a unique, descriptive identifier for the session. This name can have a maximum of 32 characters.

Virtual Path ID (VPI)

Enter the value (from 0 to 4,095) provided by the service provider. The number identifies the virtual path that transports ATM cells between the modem and the service provider. This value must match the virtual path identification (VPI) value the service provider uses for this connection.

Virtual Channel ID (VCI)

Enter the value (from 32 to 65,535) provided by the service provider. The number identifies the virtual channel for this session that transports ATM cells between the modem and the service provider. This value must match the virtual channel identification (VCI) value the service provider uses for this connection.

ATM QoS

Select the ATM Quality of Service indicated by your service provider. The options are:

- **UBR** (unspecified bit rate is the default setting)
- **CBR** (constant bit rate)
- **VBR-rt** (variable bit rate real-time)
- **VBR-nrt** (variable bit rate non-real-time)

QoS Peak Cell Rate

Enter the QoS Peak Cell Rate (PCR) value supplied by your service provider. If you are not provided a PCR value, use the default. PCR is the maximum rate at which data is transferred on the line and measured in ATM cells per second. The valid range is 1-5500 cells per second. The default PCR is 5500.

QoS Sustainable Cell Rate

Enter the QoS Sustainable Cell Rate (SCR) value supplied by your service provider. Use for VBR-rt, and VBR-nrt ATM QoS. SCR is the average rate at which ATM cells are transferred, measured in cells per second. The SCR must be less than the PCR. The valid range is 1-5500 cells per second.

QoS Maximum Burst Size

Enter the QoS Maximum Burst Size (MBS) value supplied by your service provider. Use with VBR-rt and VBR-nrt QoS. MBS is the maximum number of cells that can be transmitted at the peak cell rate. The MBS rate must be equal to or less than the PCR. The default MBS is 0.

Encapsulation

Select the encapsulation type as indicated by the service provider. The options are:

- **LlcRouted**—Logical Link Control allows multiple protocols to be run over the session. This is the default encapsulation.
- **VcMuxRouted**—Virtual Channel Multiplexer-based encapsulation allows one protocol to be run over the session.

DHCP Client

Select to enable DHCP client where this session will automatically received an IP address from the service provider via a DHCP server. If you select DHCP client, leave the next two fields, IP address and Subnet Mask, blank. These fields will automatically receive values.

IP Address

Enter the IP address provided by the service provider for this session. Or if DHCP Client was selected, the IP address will automatically be assigned by a DHCP server on the WAN side of the network. The default IP address is 0.0.0.0.

Subnet Mask

Enter the subnet mask provided by the service provider for this session or use the default subnet mask for the session which is 255.0.0.0. Or if DHCP Client was selected, the subnet mask will automatically be assigned by a DHCP server on the WAN side of the network.

RIP Send

This session forwards RIP version 1 (**Ver 1**), RIP version 2 multicast (**Ver2 (M-cast)**), RIP version 2 broadcast (**Ver2 (B-cast)**), or all versions of RIP packets. Select the RIP version or versions the modem will send on this session. The default is **Ver2 (B-cast)**.

RIP Accept

This session receives RIP version 1 (**Ver 1**) only, RIP version 2 (**Ver 2**) only, or both versions of RIP packets. Select the RIP version or versions the modem will receive for this session. The default is RIP **Ver 1** and **Ver 2**.

- 2 Click **Create** to add the new RFC1483-Router session to your session list on the **WAN Configuration** page.

Set Up a PPPoA or PPPoE Routed Session

You selected either **PPPoA routed** or **PPPoE routed** from the **WAN Configuration** page to display the following page. The **PPPoA routed** configuration page is shown below as an example. The configuration parameters for **PPPoE routed** are identical.

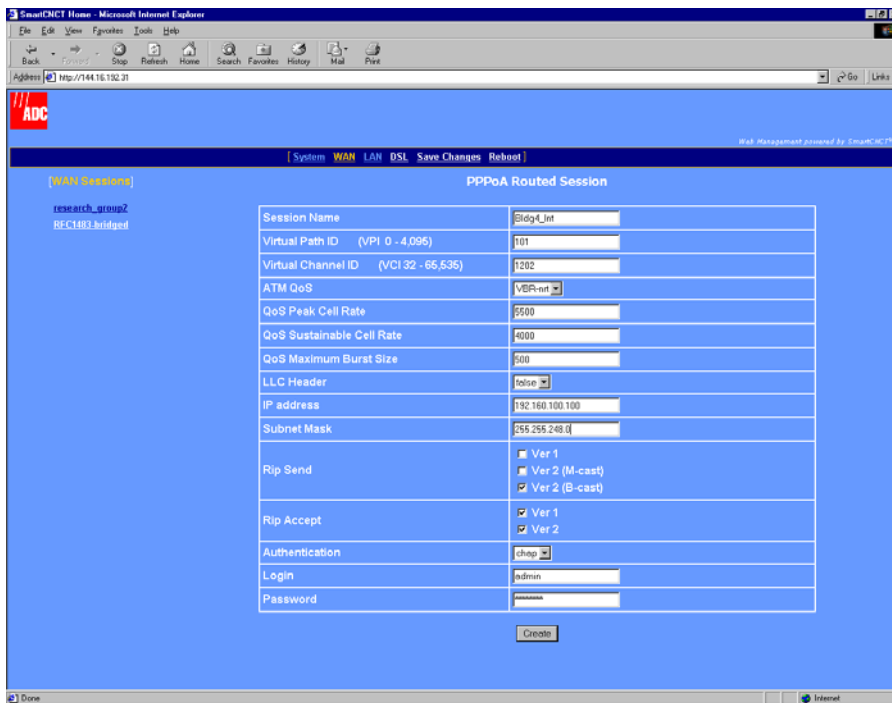

- 1 Configure the following parameters for each session:

Session Name

Enter a unique, descriptive identifier for the session. This name can have a maximum of 32 characters.

Virtual Path ID (VPI)

Enter the value (from 0 to 4,095) provided by the service provider. The number identifies the virtual path that transports ATM cells between the modem and the service provider. This value must match the virtual path identification (VPI) value the service provider uses for this connection.

Virtual Channel ID (VCI)

Enter the value (from 32 to 65,535) provided by the service provider. The number identifies the virtual channel for this session that transports ATM cells between the modem and the service provider. This value must match the virtual channel identification (VCI) value the service provider uses for this connection.

ATM QoS

Select the ATM Quality of Service indicated by your service provider. The options are:

- UBR (unspecified bit rate is the default setting)
- CBR (constant bit rate)
- VBR-rt (variable bit rate real-time)
- VBR-nrt (variable bit rate non-real-time)

QoS Peak Cell Rate

Enter the QoS Peak Cell Rate (PCR) value supplied by your service provider. If you are not provided a PCR value, use the default. PCR is the maximum rate at which data is transferred on the line and measured in ATM cells per second. The valid range is 1-5500 cells per second. The default PCR is 5500.

QoS Sustainable Cell Rate

Enter the QoS Sustainable Cell Rate (SCR) value supplied by your service provider. Use for VBR-rt, and VBR-nrt ATM QoS. SCR is the average rate at which ATM cells are transferred, measured in cells per second. The SCR must be less than the PCR. The valid range is 1-5500 cells per second.

QoS Maximum Burst Size

Enter the QoS Maximum Burst Size (MBS) value supplied by your service provider. Use with VBR-rt and VBR-nrt QoS. MBS is the maximum number of cells that can be transmitted at the peak cell rate. The MBS rate must be equal to or less than the PCR. The default MBS is 0.

LLC Header

Select either **true** or **false** for the LLC header. The default is false. False indicates that VCMux encapsulation is used. True indicates that LLC/Snap encapsulation is used.

IP Address

The IP address is dynamically served by the service provider for this session. When the modem has received the IP address for this session, it displays the value in this field. Also, the IP address dynamically received for the first PPP session set up is assigned as the default gateway (see [page 44](#)).

If the service provider does not dynamically provide an IP address, they can give you a static IP address that you can enter in this field.

Subnet Mask

The subnet mask is dynamically served by the service provider for this session. The default subnet mask for the session is 0.0.0.0.

If the service provider does not dynamically provide a subnet mask, they can give you a subnet mask value that you can enter in this field.

RIP Send

This session forwards RIP version 1 (**Ver 1**), RIP version 2 multicast (**Ver2 (M-cast)**), RIP version 2 broadcast (**Ver2 (B-cast)**), or all versions of RIP packets. Select the RIP version or versions the modem will send on this session. The default is **Ver2 (B-cast)**.

RIP Accept

This session receives RIP version 1 (**Ver 1**) only, RIP version 2 (**Ver 2**) only, or both versions of RIP packets. Select the RIP version or versions the modem will receive for this session. The default is RIP **Ver 1** and **Ver 2**.

Authentication

Select the authentication protocol provided by your service provider for PPP sessions. The authentication protocol type must match at the modem and the service provider. The options are:

- **PAP**—The modem sends authentication requests to the service provider and authentication occurs only once during the life of the DSL link.
- **CHAP**—The service provider returns an authentication challenge to the modem during the authentication (default setting).
- **NONE**—No authentication is required for the session.

Login

Change the default login name (**admin**) for this PPP session to the **Login** name supplied by the service provider. Minimum login name length is one character and the maximum is 32 characters.

Password

Change the default login password (**password**) for this PPP session to the **Login** password supplied by the service provider. Minimum password length is six characters and the maximum is 32 characters.

- 2 Click **Create** to add the new PPPoA or PPPoE session to your session list on the **WAN Configuration** page.

Permanently Save Sessions

After you have set up all the WAN sessions, save these changes permanently as described in [Chapter 5, “Saving Changes.”](#)

EDIT A WAN SESSION

You can change parameters for any of the 32 PPPoA, PPPoE, 1483-Bridge, and 1483-Router sessions for the modem. See [page 25](#) for the limits on sessions per each protocol type. From the WAN configuration page, configure the parameters for each session you will set up.

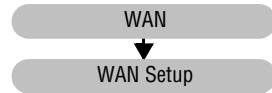

- 1 Select **WAN** on the menu bar to access the **WAN Configuration** page.



- 2 Select a session from the **[WAN Sessions]** list. The configuration options for that WAN session is displayed.

The following shows the fields you can edit for a routing session or you can delete the session. The **Protocol** field at the top of the dialog is read-only. It indicates the protocol that you previously selected for this session.

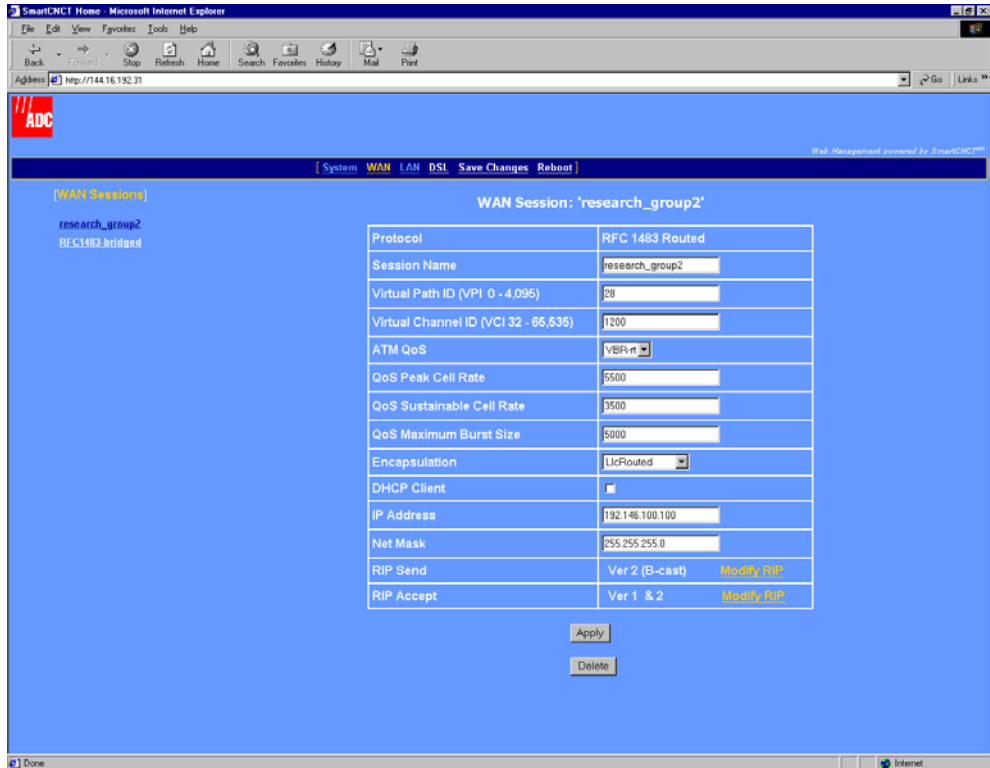

The following shows the fields you can edit for a PPP session or you can delete the session. The **Protocol** field at the top of the dialog is read-only. It indicates the protocol that you previously selected for this session.

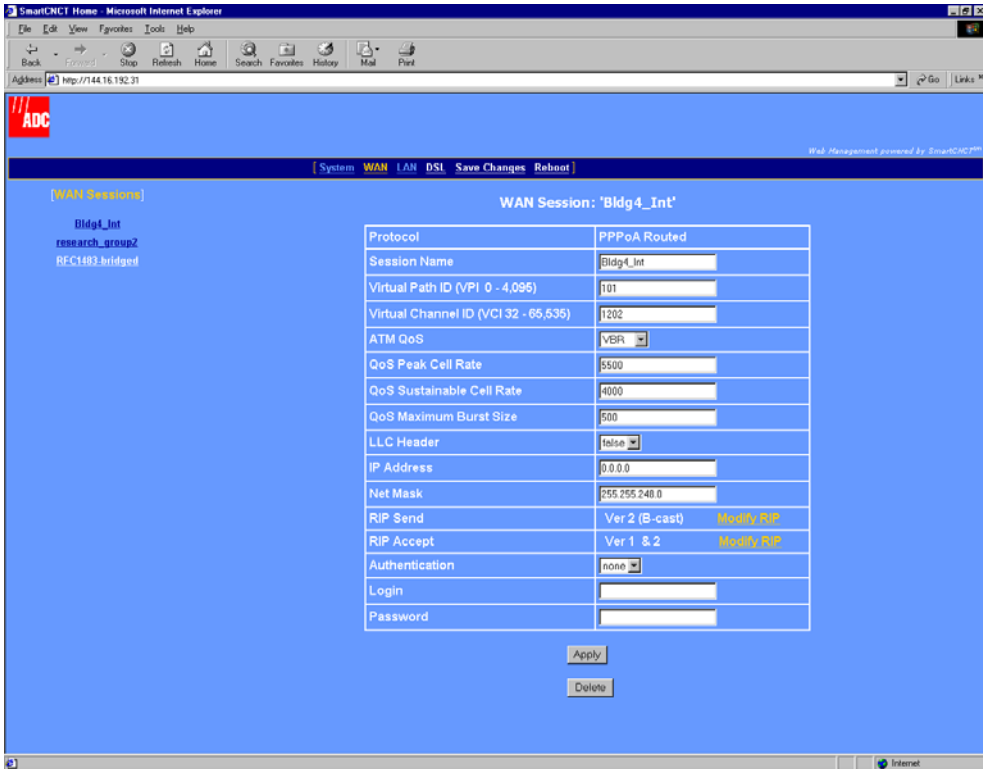

- 3 Change session parameters as required. Go to the following pages for parameter definitions based on the protocol used for that session:
 - For an RFC1483-Bridge session, go to [page 27](#).
 - For an RFC1483-Routed session, go to [page 29](#).
 - For a PPPoA Routed session, go to [page 32](#).
 - For a PPPoE Routed session, go to [page 32](#).
- 4 Do one of the following:
 - Click **Apply**, then save changes as described in [Chapter 5, “Saving Changes.”](#)
 - Click **Delete** to entirely remove the session, then save changes as described in [Chapter 5, “Saving Changes.”](#)

CONFIGURING SYSTEM PARAMETERS

5

These configuration parameters affect system functions for the modem. Other system parameters used to manage or troubleshoot the modem (updating modem software, for example) are in [Chapter 9, “Managing the Modem.”](#)

BEFORE YOU BEGIN. . .

Determine the following before changing system parameters:

- If secured management access is required for the modem, add users and assign one of three predefined security levels: Default, Engineer, or Super User.
- If SNMP authentication is required, add SNMP communities with either read or write access.
- Add the IP address for the network default router through which packets are forwarded.
- If static routes will be used to predetermined destinations, identify the destination host or network IP address. Also, identify the next hop gateway IP address for devices on your LAN (for example, the modem LAN port IP address).
- If spanning tree protocol is required, based on one or both of the following conditions, then enable it:
 - RFC 1483-Bridge protocol is used for any session or for the 10Base-T port (LAN)
 - there are multiple bridging devices on a LAN with more than one physical path connecting them and you want to prevent loops

Otherwise, disable spanning tree protocol.

ASSIGNING USER ACCESS

The modem provides secure access for managing and viewing modem configuration. Three levels of access are predefined and can be assigned to users you set up. These security logons are required for access to the Web interface or to access the command-line interface through either the console port or through a telnet session.

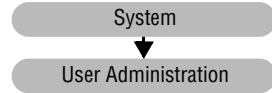

For the three levels of predefined access, it is recommended that you change the passwords for all three accesses to secure the modem for management. The following procedures show how to add, modify, or delete user accounts.

- 1 Select **System** on the menu bar, then select **User Administration** under [**Configuration**] to access the **Users' List** page.

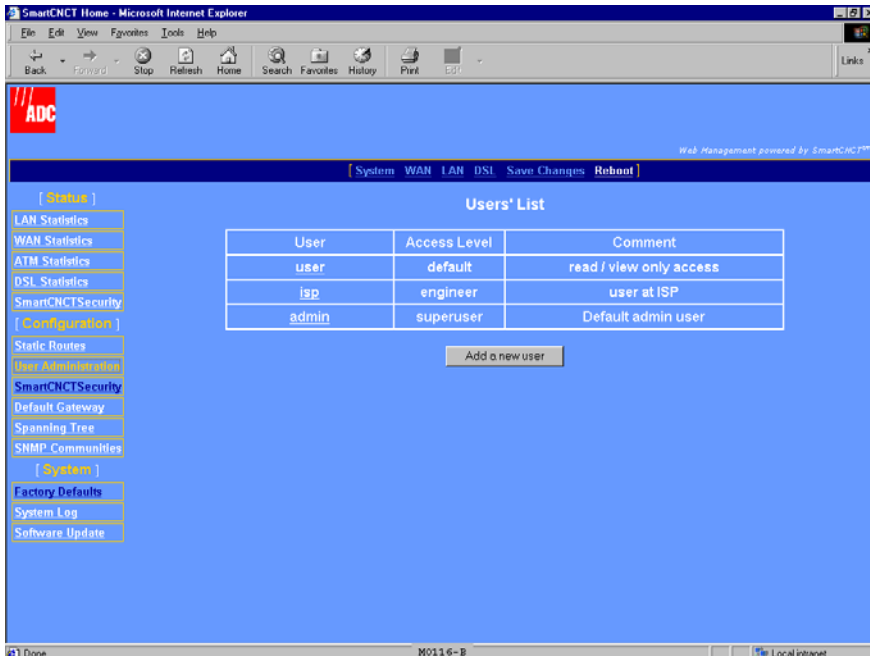

- 2 To add a new user account, do the following:
 - a Click **Add a new user**. The following dialog is displayed.

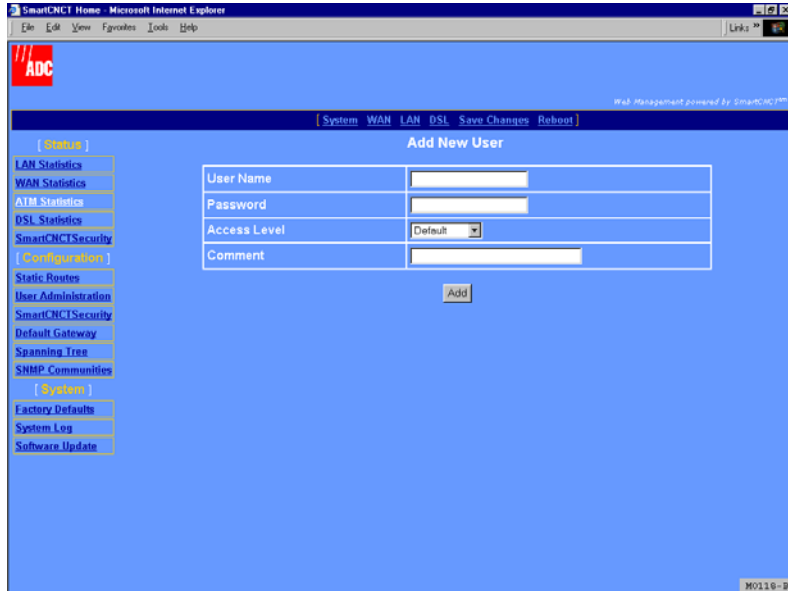

It is important to change the password for all three default user accounts to ensure secure access to modem for configuration and management.

- b Enter the following information:

User Name

The login name for this user. The login name can be a maximum of 32 characters and all keyboard characters, except a space, are allowed.

Password

The password associated with this user login. The password must be a minimum of six and a maximum of 32 alphanumeric characters (including caps and lowercase).

<i>Defaults</i>	
User Name	admin
Password	password
Access level	superuser
User Name	isp
Password	password
Access level	engineer
User Name	user
Password	password
Access level	default

Access Level

The level of access to modem configuration and management allowed for this user. Choose from the following access levels.

Access Level	Definition
Super User	This user has full administrative access to the modem. This includes full view and write access to all modem configuration and management.
Engineer	This user has write access to all LAN-side and DSL configuration (including DSL testing) only. All other configuration access (WAN session and System) is view only.
Default	This user has view only access to all modem configuration and management. Default is the default access level when setting up new user accounts.

Comment

Identifies the user in a way that is meaningful to you. All keyboard characters are allowed.

- c Click **Add**. The new entry is added to and is displayed in the **Users' List** table (see [page 40](#)).

- 3 To modify or delete an existing user entry, do the following:



It is important to change the default password for all three default user accounts to ensure secure access to modem for configuration and management.

- a From the **Users' List** table (see page 40), select the name in the **User** column that you want to change or delete. The following dialog is displayed.

The screenshot shows a web browser window titled "SmartCNCI Home - Microsoft Internet Explorer". The main content area is titled "User Configuration" and contains a form with the following fields:

User Name	Jane_Doe
Password	XXXXXXXXXX
Access Level	engineer
Comment	network engineering gip

Below the form are two buttons: "Apply" and "Delete". The left sidebar contains a navigation menu with items like LAN Statistics, WAN Statistics, ATM Statistics, DSL Statistics, SmartCNCISecurity, Configuration, Static Routes, User Administration, SmartCNCISecurity, Default Gateway, Spanning Tree, SNMP Communities, System, Factory Defaults, System Log, and Software Update.

- b To modify the user account, change any of the parameters. Click **Apply**.
- c To delete the user account, click **Delete**. The user account is immediately removed from the **Users' List** table.

ADD A DEFAULT GATEWAY

The modem default gateway is a IP address through which packets are routed to the internet if the next hop IP address cannot be identified by the modem. Use either the IP address of a WAN session or 0.0.0.0 (default value).

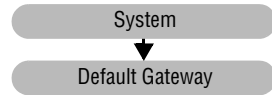

When setting the modem default gateway, if the first session you set up was a PPP session, the IP address that was dynamically assigned to that PPP session was also automatically assigned as the default gateway. If you do not want this IP address (PPP WAN session) as the default gateway, then use this page to change it to another value.

- 1 Select **System** on the menu bar, then select **Default Gateway** under **[Configuration]** to access the **Default Gateway** page.

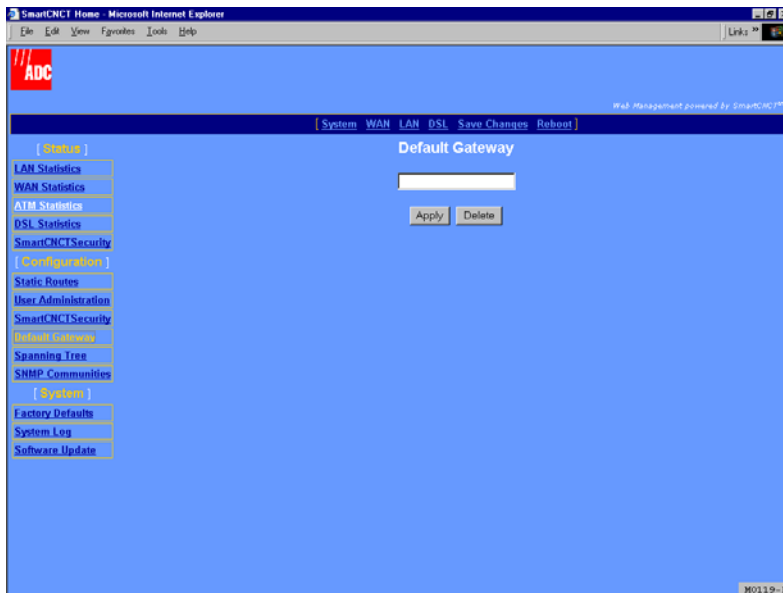

- 2 To add a default gateway, enter the IP address for the gateway through which the modem will forward packets. Click **Apply**.
- 3 To remove the default gateway IP address, click **Delete**.

ADD STATIC ROUTE ENTRIES

A static route provides a defined path from one host or network to a destination host or network. This type of route is manually entered as a fixed path, as contrasted to a dynamic route which is automatically determined and learned (RIP, for example). If the next gateway for network traffic is unknown, a static route will be its default path.

System



Static Routes

- 1 Select **System** on the menu bar, then select **Static Routes** under **[Configuration]** to access the **Static Routes** page.



- 2 To add a new static route, do the following:
 - a On the **Static Routes** page, click **Create a new IP route**. The following dialog is displayed.

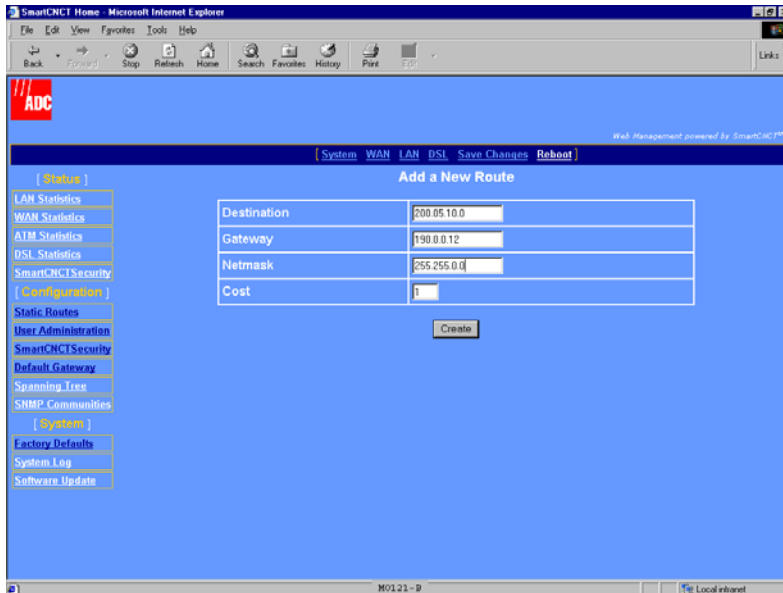

- b Enter the following information for the static route.

Destination

The IP address for the destination network, subnet, or host to which the packets are directed. Use 0.0.0.0 as the destination IP address for a default route.

Gateway

The IP address for the next hop in your network to which the packets are forwarded. For example, if your network is connected either directly or through a hub to the LAN port of the modem, then the LAN port IP address can be the next hop. Or, a WAN port can be the next hop for traffic.

Netmask

The network mask defining the route and access for the destination IP address.

Cost

The number of hops (gateways) from 1 to 15 through which this traffic can pass before reaching its destination.

- c Click **Create**. The new entry is added to and is displayed in the **Static Routes** table (see page 45).
- 3 To delete a static route entry, do the following:
- a From the **Static Routes** table (page 45), click the IP address in the **Destination** column that you want to delete. The following dialog is displayed.



- b Click **Delete** to remove the static route entry or click **Cancel** to stop the operation and return to the **Static Routes** table.

ADD SNMP COMMUNITIES

An SNMP community provides the authentication and authorization, through its community string, to view and/or change modem parameters.

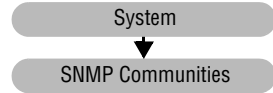

- 1 Select **System** on the menu bar, then select **SNMP Communities** under **[Configuration]** to access the **SNMP Community List** page. Go to step 2 to add an SNMP community or go to step 3 to change or delete an existing SNMP community.

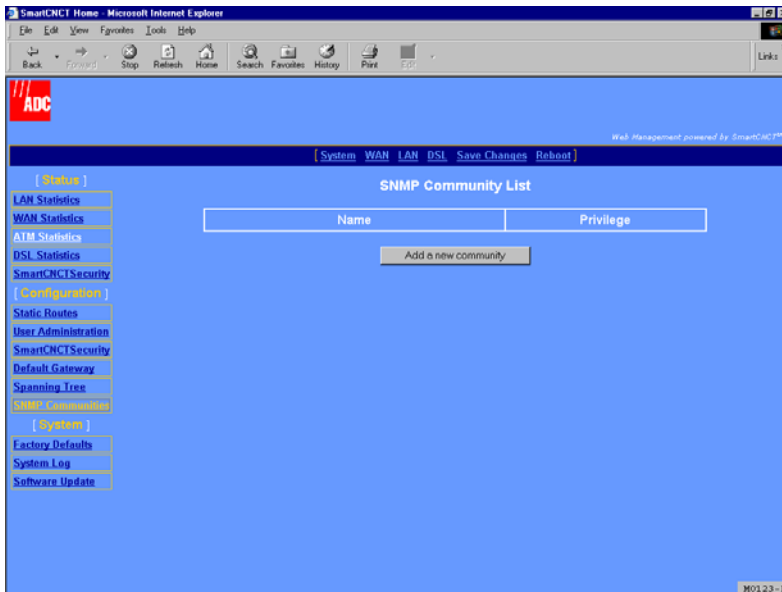

- 2 To add a new SNMP community, do the following:
 - a On the **SNMP Community List** page, click **Add a new community**. The following dialog is displayed.

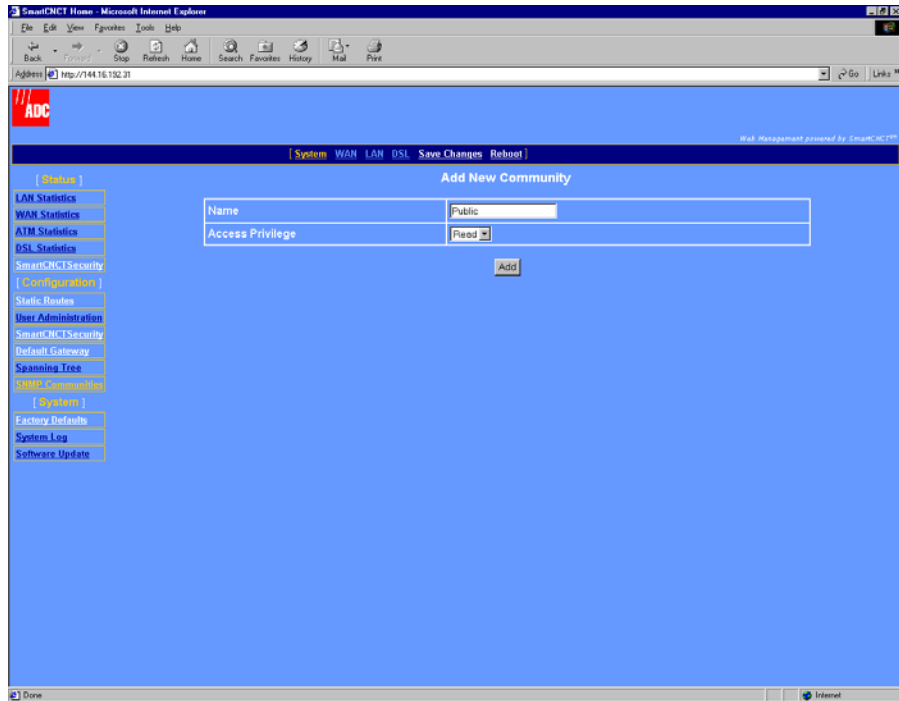

- b Enter the following information for the SNMP community.

Name

Identification for this SNMP community. All keyboard characters are allowed for this name, up to a maximum of 80 characters. You must add a community name in this field to later edit or delete the SNMP community. This name in the **SNMP Community List** table provides the link for editing or deleting the entry.

Access Privilege

The access allowed to this SNMP community. Accesses are either **Read** (view-only access) or **Write** (full view and write access).

- c Click **Add**. The new entry is added to and is displayed in the **SNMP Community List** table (see [page 48](#)).

- 3 To modify or delete an SNMP community, do the following:
 - a From the **SNMP Community List** table, select the SNMP community **Name**. The following dialog is displayed.

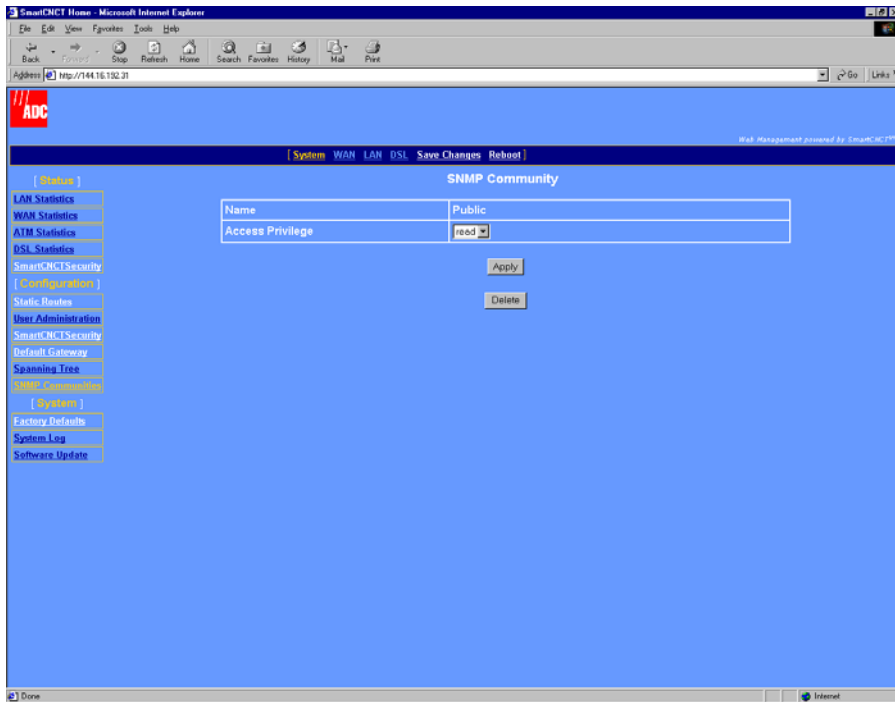

- b Do one of the following:
 - Change the **Access Privilege**, then click **Apply**.
 - Click **Delete** to remove the static SNMP community.

CHANGE SPANNING TREE SETTING

Spanning tree eliminates loops in a LAN topology, ensuring that there is only one path (or link) between any two nodes in a network. Use spanning tree protocol (STP) when RFC 1483-Bridge protocol is assigned to either or both of the following:

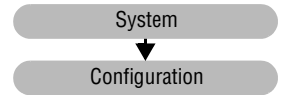

- WAN sessions (see “Configure a New WAN Session” on page 26)
- LAN port and the LAN has more than one device (PCs and servers, for example) and those devices have more than one physical path connecting them.

The default spanning tree setting is disabled. Access spanning tree configuration as follows:

- 1 Select **System** on the menu bar, then select **Spanning Tree** under **[Configuration]** to access the **Bridge Spanning Tree** page.



- 2 Enter the following parameters to enable STP for bridging sessions:

Spanning Tree

Select **Enable** to activate the STP for all RFC 1483-Bridge sessions. **Disable** turns off STP for all modem bridging sessions.

Priority

The modem STP priority (how centrally located this bridge is) in the network. A lower number indicates a more centrally located bridge. The valid priority range is 0 to 65535. A priority of 32768 is the default value.

Hello Time

The time interval in seconds at which the modem should send STP packets. Default value is 2 seconds.

Forward Delay

The time interval in seconds that should be waited until the state of an interface can change. This delay prevents interface states from changing so rapidly that STP cannot keep up with the current network topology and therefore cannot efficiently managing bridging. Default value is 15 seconds.

Max Age

The time interval in seconds after which Spanning Tree entries that are not relearned are deleted from the bridging table. Default value is 20 seconds.

SAVING CHANGES

Use the **Save Changes** page for saving your current configuration to flash memory. This option immediately writes all current system configuration to permanent memory (NVRAM). You cannot selectively write configuration to NVRAM. When you issue the save command, all current configuration is written to NVRAM.

Save Changes



When saving the modem configuration, do not power off the modem while the save is in process.

- 1 Select **Save Changes** on the menu bar to access the **Save Changes** page.

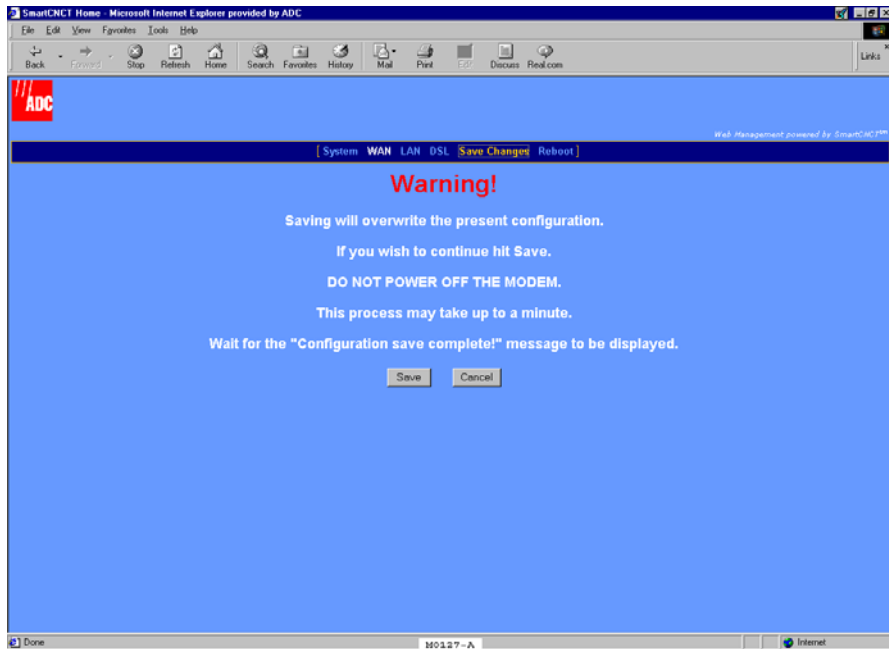

2 Do one of the following:

- Click **Save** to write the configuration to flash memory and do not power off the modem while the save is in progress. The following dialog is displayed when the save is completed.

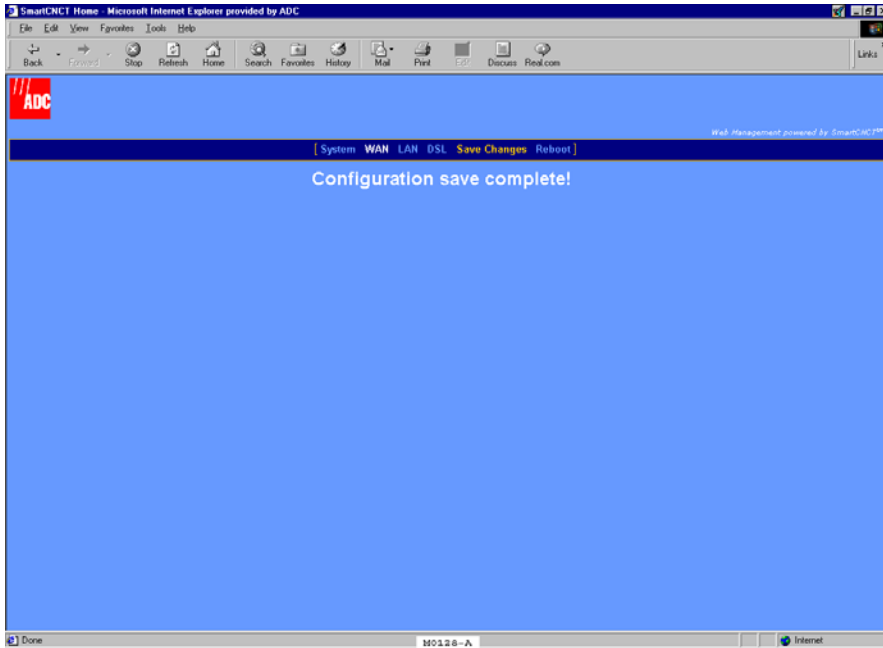

- Click **Cancel** to exit the current page without saving your configuration.

REBOOTING THE MODEM

Before rebooting the modem, save any configuration changes you have made using the steps in “Saving Changes” on page 53.

Reboot

- 1 Select **Reboot** on the menu bar to access the **Reboot** page.



- 2 Do one of the following:
 - Click **Yes** to reboot the modem.
 - Click **No** to cancel the rebooting process.

CONFIGURING DSL PARAMETERS

6

The DSL parameters set up the G.shdsl communication between the modem and a DSLAM or between two modems used in a point-to-point application. Typically, the DSL parameters for the modem are preset to immediately synchronize with the service provider (DSLAM application). However, you may be instructed to make changes to the DSL configuration. This chapter provides information for setting G.shdsl parameters when the modem is in an application as a DSLAM endpoint. For instruction on setting up G.shdsl parameters for a point-to-point modem application, go to [Chapter 7, “Implementing a Point-to-Point LAN Extension.”](#)

BEFORE YOU BEGIN. . .

The following are configurable DSL parameters for the G.shdsl modem; change parameters only when instructed to do so by the service provider or your system administrator.

- The operating mode choices are Remote (use when the modem is an endpoint for a DSLAM application or the customer-side modem in a point-to-point application) or Central-Office (use only for the central office-side modem in a point-to-point application)
- Annex A or B provides the appropriate operating characteristics for G.shdsl, dependent on your geographical location.
- A margin value, in decibels, that must be met to initialize modem.
- Either fixed or adaptive mode that the modem will use to negotiate the best transmission rate at which both ends of the connection can synchronize.
- Wire pair mode, either Single (two-wire) or Dual (four-wire), can be selected only for the MM702G modem. The MM701G modem is used only in Single mode.
- PSD mask is either symmetric or asymmetric. The values used to calculate the asymmetric mask are dependent on the Annex A or B you selected.

COMPLETE A G.SHDSL QUICK CONFIGURATION

Configure basic operating parameters for the modem.

- 1 Select **DSL** on the menu bar, then select **Quick Configuration** under **[DSL Options]**.

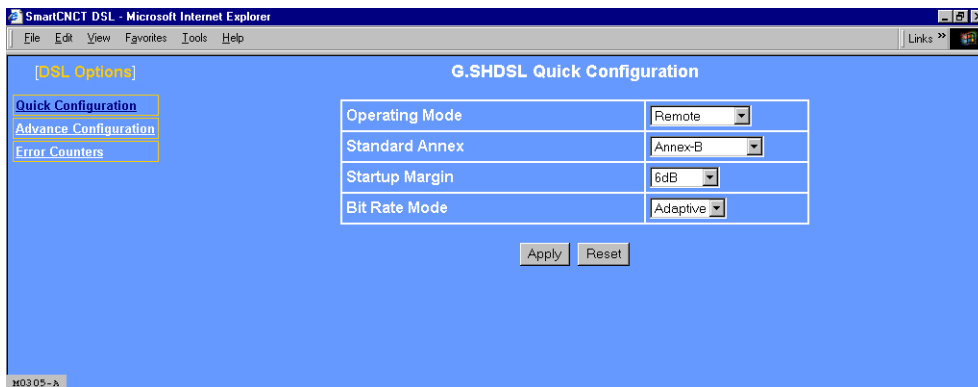
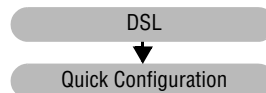

- 2 Configure the following parameters as directed by your service provider:

Operating Mode

When the modem is connected to a service provider through a DSLAM, the operating mode is **Remote** (default setting).

When two modems are used in a point-to-point application (LAN extension, for example), one modem at the customer or user site is set to **Remote** and the second modem in the CO or wiring closet is set to **Central-Office**. For instruction on setting up G.shdsl parameters and other related parameters for a point-to-point modem application, go to [Chapter 7, “Implementing a Point-to-Point LAN Extension.”](#)

Standard Annex

Select one of the following Annexes:

- **Annex-A** for operating conditions typically found in the North American implementation of G.shdsl
- **Annex-B** for operating conditions typically found in the European implementation of G.shdsl. This is the default mode for the MM701G modem.

- **Auto** for automatically negotiating the Annex A or B standard by which this modem, and the device to which this modem is attached, can operate. This is the default mode for the MM702G modem.
- **Annex-B_ANFP** for operating conditions that include the Annex B standard with Access Network Frequency Plan Pulse Spectral Density (PSD) mask.
- **Auto_ANFP** for automatically negotiating the Annex A or B standard with Access Network Frequency Plan Pulse Spectral Density (PSD) mask.

Startup Margin

The target signal-to-noise margin, in decibels, that the modem must achieve with a BER of 10^{-7} or better to successfully complete synchronization. The default margin value is 6 dB. A lower margin may result in a higher data rate, but it can increase noise on the line. Possible values are **-10dB** through **10dB**, or to completely **Disable** the margin.

Bit Rate Mode

Bit rate mode indicates how the modem synchronizes with the device to which it is attached in either a **Fixed** or **Adaptive** mode. The default for the MM702G modem is **Fixed** mode. The default for the MM701G modem is **Adaptive** mode.

- **Fixed** mode indicates that the modem will synchronize with the other end (a DSLAM or another modem) at a fixed bit rate through negotiation. The modem will synchronize at the best rate, up to the data rate specified ([page 61](#)), that can be achieved by both ends.
- **Adaptive** mode indicates that prior to modem negotiating a rate, the modem performs an adaptation phase during which it determines a best possible rate based on conditions of the line. After adaptive mode, the modem will then negotiate the best rate that can be achieved with the other end, based on the adaptation results.

3 Click **Apply**.

COMPLETE A DSL ADVANCED CONFIGURATION

Configure the G.shdsl parameters for the modem to facilitate it synchronizing with either a DSLAM or another modem to which it attaches.

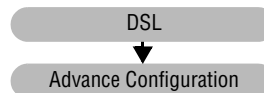

- 1 Select **DSL** on the menu bar, then select **Advance Configuration** under **[DSL Options]**.

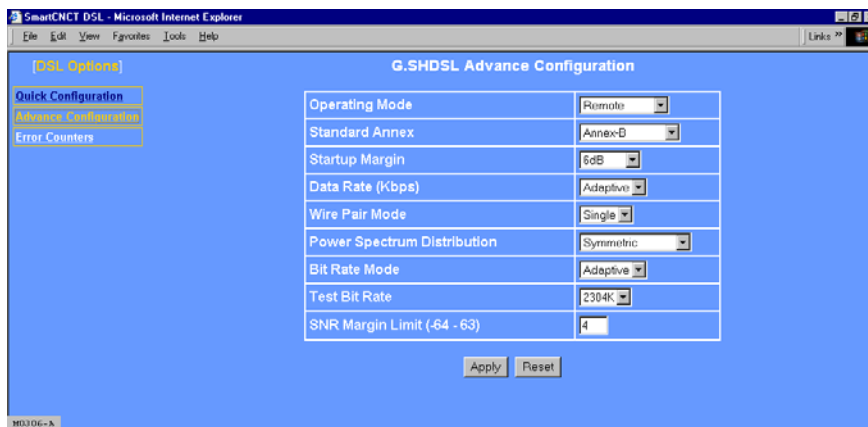

- 2 Configure the following parameters as directed by your service provider:

Operating Mode

When the modem is connected to a service provider through a DSLAM, the operating mode is **Remote** (default setting).

When two modems are used in a point-to-point application (LAN extension, for example), one modem at the customer or user site is set to **Remote** and the second modem in the CO or wiring closet is set to **Central-Office**. For instruction on setting up G.shdsl parameters and other related parameters for a point-to-point modem application, go to [Chapter 7, "Implementing a Point-to-Point LAN Extension."](#)

Standard Annex

Determines the transmission standards to which this G.shdsl connection will comply. The Annex standard should be the same at both ends of the connection. Select one of the following Annexes:

- **Annex-A** for operating conditions typically found in the North American implementation of G.shdsl

- **Annex-B** for operating conditions typically found in the European implementation of G.shdsl. This is the default mode for the MM701G modem.
- **Auto** for automatically negotiates the Annex A or B standard by which this modem, and the device to which this modem is attached, can operate. This is the default mode for the MM702G modem.
- **Annex-B_ANFP** for operating conditions that include the Annex B standard with Access Network Frequency Plan Pulse Spectral Density (PSD) mask.
- **Auto_ANFP** for automatically negotiating the Annex A or B standard with Access Network Frequency Plan Pulse Spectral Density (PSD) mask.

Startup Margin

The target signal-to-noise margin, in decibels, that the modem must achieve with a BER of 10^{-7} or better to successfully complete synchronization. The default margin value is 6 dB. A lower margin may result in a higher data rate, but it can increase noise on the line. Possible values are **-10dB** through **10dB**, or to completely **Disable** the margin.

Data Rate (kbps)

Data rate determines the maximum transmission rate, in kilobits per second, up to which the modem can negotiate and synchronize with another device (modem or a DSLAM) to which it is attached. When the **Bit Rate Mode** (page 62) is set to **Fixed**, the range of values are (ADC modems comply with the standard G.shdsl data rate range):

- for the MM702G modem, 384 kbps to 4608 kbps, in 128 kbps increments (default value is 4608)
- for the MM701G modem, 192 kbps to 2304 kbps, in 64 kbps increments

Rates down to 64 kbps are supported only when operating in single-pair, point-to-point mode with another ADC modem. (see Chapter 7, “Implementing a Point-to-Point LAN Extension”).

When the **Bit Rate Mode** (page 62) is set to **Adaptive** for an MM701G (**Adaptive** is MM701G default value) or for an MM702G set to **Single Wire Pair Mode** only (see below), this field is automatically set to **Adaptive**. An MM702G in **Dual Wire Pair Mode** cannot be used in **Adaptive Bit Rate Mode**.

Wire Pair Mode

Indicates whether the G.shdsl modem is operating in a two-wire mode (**Single**) or a four-wire mode (**Dual**). For the MM701G modem, **Single** mode is the only setting available. For the MM702G modem, you can select either **Single** or **Dual** mode and **Dual** mode is the default.

Power Spectrum Distribution

The Power Spectral Density (PSD) plots the variations of signal power with signal frequency for the G.shdsl transmission between the modem and the DSLAM or the modem and another modem. **Symmetric** PSD indicates that the PSD mask for both sides of the transmission (the CO- and remote-side) are the same (symmetric).

Asymmetric PSD indicates that the PSD mask for both sides of the transmission (the CO- and remote-side) are not the same (asymmetric). There are two unique numeric values (**AsymmetricRate1** and **AsymmetricRate2**) used to determine the asymmetric PSD mask based on the Annex A or Annex B standard that you selected (see [page 60](#)). **AsymmetricRate1** is 784 kbps for Annex A and 2312 kbps for Annex B. **AsymmetricRate2** is 1552 kbps for Annex A and 2056 kbps for Annex B.

Both ends of the connection must be set for the same Symmetric or Asymmetric PSD. The default is **Symmetric**.

Bit Rate Mode

Bit rate mode indicates how the modem synchronizes with the device to which it is attached in either a **Fixed** or **Adaptive** mode. The default for the MM702G modem is **Fixed** mode. The default for the MM701G modem is **Adaptive** mode.

- **Fixed** mode indicates that the modem will synchronize with the other end (a DSLAM or another modem) at a fixed bit rate through negotiation. The modem will synchronize at the best rate, up to the data rate specified ([page 61](#)), that can be achieved by both ends.
- **Adaptive** mode indicates that prior to modem negotiating a rate, the modem performs an adaptation phase during which it determines a best possible rate based on conditions of the line. After adaptive mode, the modem will then negotiate the best rate that can be achieved with the other end, based on the adaptation results. An MM702G in **Dual Wire Pair Mode** cannot be used in **Adaptive Bit Rate Mode**.

Test Bit Rate

This bit rate is used by the manufacturer for internal use only.

SNR Margin Limit

Identifies the minimum SNR margin (in decibels) that must exist when the G.shdsl connection is synchronized and in order for the DSL MAR LED to be lit ON Green. The range of values is -64 to 63. The default value is 4.

- 3 Click **Apply** then save changes using “Saving Changes” on [page 53](#).

IMPLEMENTING A POINT-TO-POINT LAN EXTENSION

7

Two ADC G.shdsl modems can be implemented in a point-to-point application (also called back-to-back). In this application, the modems can be used to connect remote LANs to create LAN extensions. In this point-to-point application, one ADC G.shdsl modem is set to Remote mode and the other ADC G.shdsl modem is set for Central-Office mode. By bridging traffic between these two modems, you essentially create one extended LAN that allows the use of a single IP subnet.

Although you can set up multiple sessions on these modems, only one RFC 1483-Bridge sessions is required for implementing a point-to-point LAN extension.

The ADC modems comply with the standard G.shdsl data rate range of 192 kbps to 2304 kbps. Additionally, rates down to 64 kbps are supported only when using the G.shdsl modem in single-pair, point-to-point mode for a LAN extension application.

BEFORE YOU BEGIN. . .

Determine which of these implementations apply for your application:

- Quick Install**—If your application does not require custom configuration, you can use the default modem settings. To implement, the Remote mode modem is already configured with factory default configuration for implementing point-to-point LAN extension; no changes are necessary for this modem to implement service. The Central-Office modem requires only two configuration changes to set the modem to Central-Office mode. These changes are described in [“Complete a Quick Installation” on page 64](#).
- Custom Configuration**—If you implement custom configuration where you do not use factory default parameters for your modems, refer to [“Complete a Custom Configuration” on page 66](#) to configure the Remote modem and to configure the Central-Office modem.

COMPLETE A QUICK INSTALLATION



The modem is shipped with factory defaults as a Remote modem and does not require any additional configuration when used as a remote. Only the Central-Office modem requires configuration changes.

In a quick installation, you change configuration only for the Central-Office mode modem. The Remote modem uses its factory default parameters. To set up the Central-Office modem, follow the instructions in the following sections. The modems use a default bridging WAN session (**RFC1483-bridged**) which has a predefined ATM connection using Virtual Path ID of 0 and Virtual Channel ID of 35.

Configure for Central-Office Mode

- 1 Select **DSL** on the menu bar, then select **Advance Configuration** under [DSL Options].

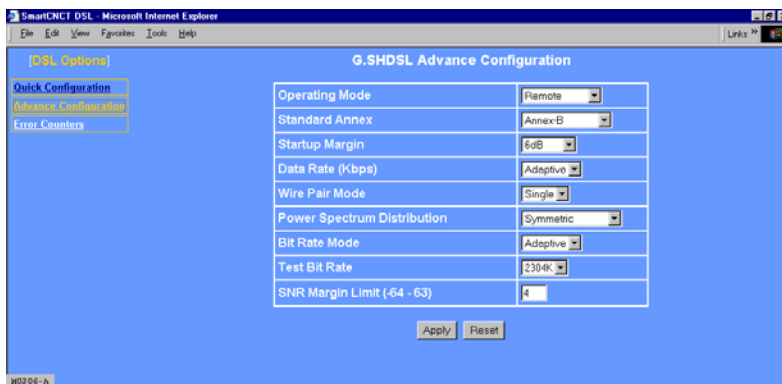

- 2 In the **Operating Mode** box, select **Central-Office** to set up this modem for this mode.
- 3 Click **Apply**.

Change the LAN IP Address for the Central-Office Modem

Because the Central-Office and Remote modems are on the same IP subnet in this point-to-point application, you must change the IP address for the Central-Office modem.

- 1 Select **LAN** on the menu bar to access the **LAN Configuration** page.

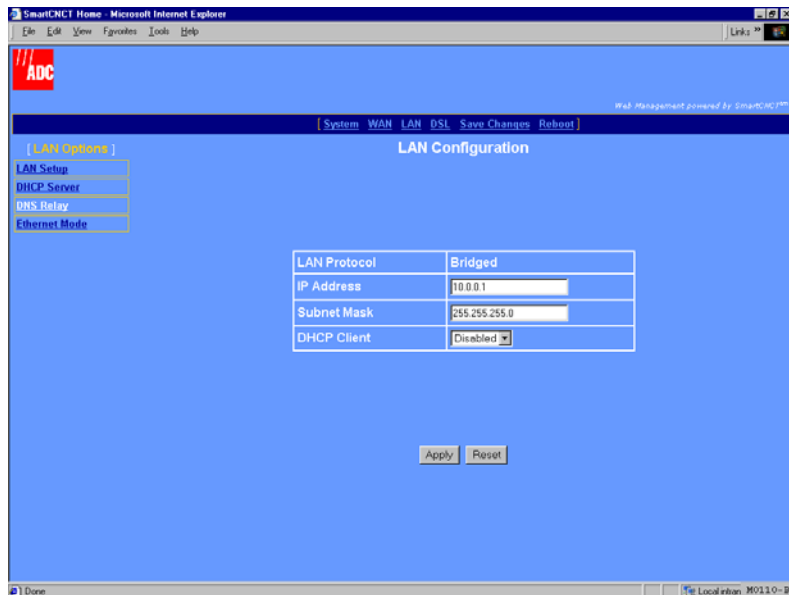

- 2 In the IP address box, enter **10.0.0.2**.



Any device (such as a PC) connecting to the modem LAN interface loses its connection when the modem LAN IP address is changed. After the IP address is changed, you need to specify this new address in the Web browser to reconnect a device.

- 3 Click **Apply** to activate the changes. The connection to the Web interface will be lost because the modem now has a new LAN IP address.
- 4 In the Web browser address field (see [page 11](#)), specify **http://10.0.0.2** to reconnect.
- 5 Click **Save Changes** on the menu bar to prevent losing the configuration after restoring communication with the modem.

You are now finished with the Quick Installation. To verify connectivity, refer to “[Verify Connectivity](#)” on [page 76](#)

COMPLETE A CUSTOM CONFIGURATION

If you implement custom configuration where you do not use factory default parameters for your modems, you will need to make changes to the configuration on both the Remote and the Central-Office modem. The following sections provide configuration changes for the Remote modem and then for the Central-Office modem.

Configure the Remote Modem

To configure the remote modem, you need to change the following settings:

- operating mode for the modem, (see “Configure the Remote Operating Mode” on page 66)
- WAN parameters, (see “Configure the Remote WAN” on page 67)
- LAN parameters, (see “Configure the Remote LAN” on page 69)

Configure the Remote Operating Mode

- 1 Select **DSL** on the menu bar then select **Advance Configuration** under [DSL Options].

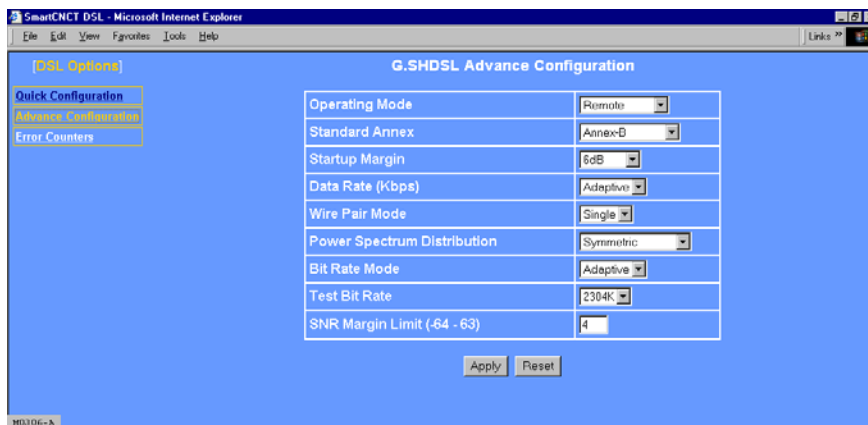

- 2 In the **Operating Mode** box, select **Remote** to configure the modem for this mode.
- 3 Click **Apply**.

Configure the Remote WAN

- 1 Select **WAN** on the menu bar to access the **WAN Configuration** page.



- 2 Select **RFC 1483 bridged** from the **WAN Configuration** page to display the following page.

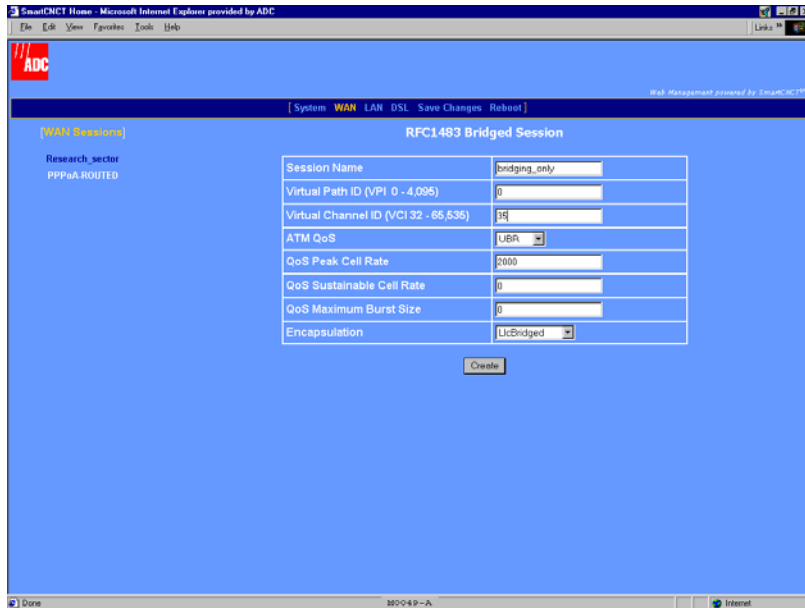

- 3 In the **Session Name** box, assign a name to this session.
- 4 In the **Virtual Path ID (VPI 0 - 4,095)** box, enter the Virtual Path ID. This must match the Virtual Path ID of the Central-Office modem.
- 5 In the **Virtual Channel ID (VCI 32 - 65,535)** box, enter the Virtual Channel ID. This must match the Virtual Channel ID of the Central-Office modem.
- 6 Click **Apply**.

Configure the Remote LAN

- 1 Select **LAN** on the menu bar, then select **LAN Setup** under **LAN Options** to access the **LAN Configuration** page.

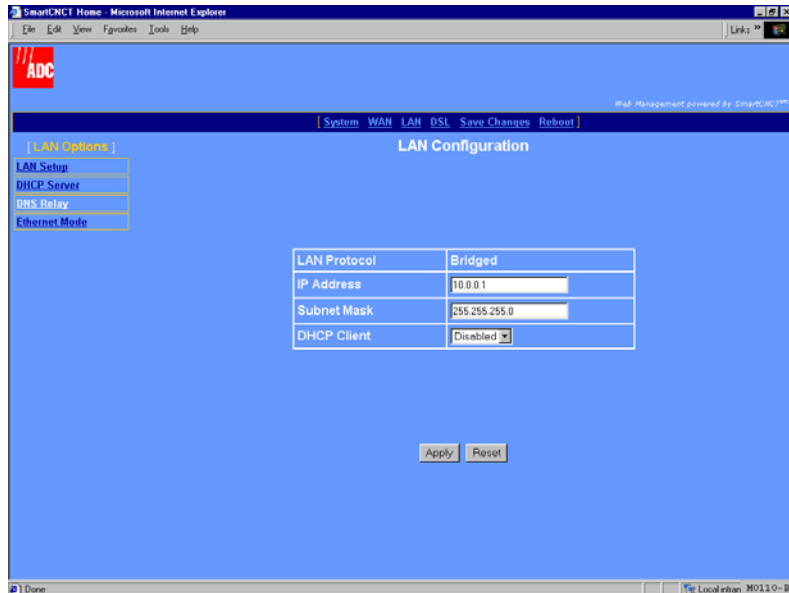

- 2 In the **LAN Protocol** box, confirm that the protocol is set to **Bridged**. If the protocol is not set to bridged, it can be changed only through the command-line interface. See [Appendix A, “Accessing the Command-Line Interface”](#) for procedures on using this interface to change the LAN protocol.



Any device (such as a PC) connecting to the modem LAN interface loses its connection when the modem LAN IP address is changed. After the IP address is changed, you need to specify this new address in the Web browser to reconnect a device.

- 3 In the **IP Address** box, enter an available IP address on your subnet.
- 4 Click **Apply**.

- 5 Select **Save Changes** on the menu bar to access the **Save Changes** page.

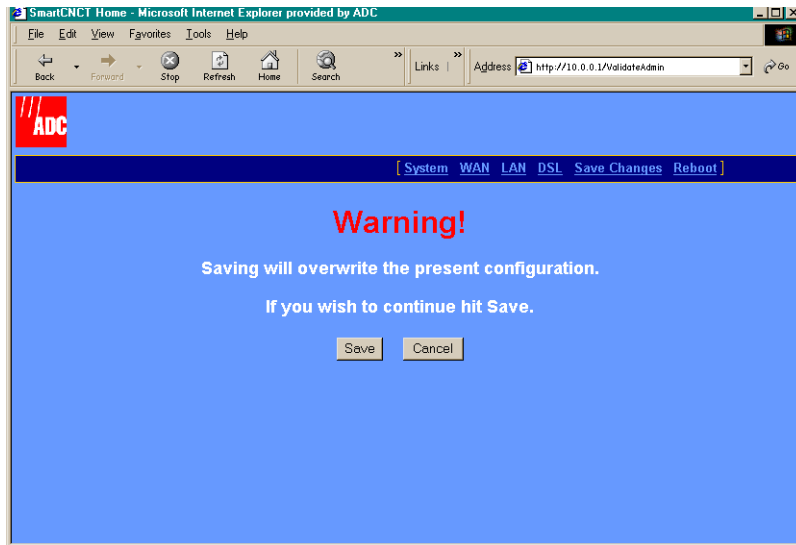

- 6 Click **Save** to save the configuration to flash memory.

Configure the Central-Office Modem

To configure the central-office modem, you need to change the following settings:

- operating mode for the modem, (see [“Configure the Central-Office Operating Mode”](#) on page 71)
- WAN parameters, (see [“Configure the Central-Office WAN”](#) on page 72)
- LAN parameters, (see [“Configure the Central-Office LAN”](#) on page 74)

Configure the Central-Office Operating Mode

- 1 Select **DSL** on the menu bar then select **Advance Configuration** under **[DSL Options]**.

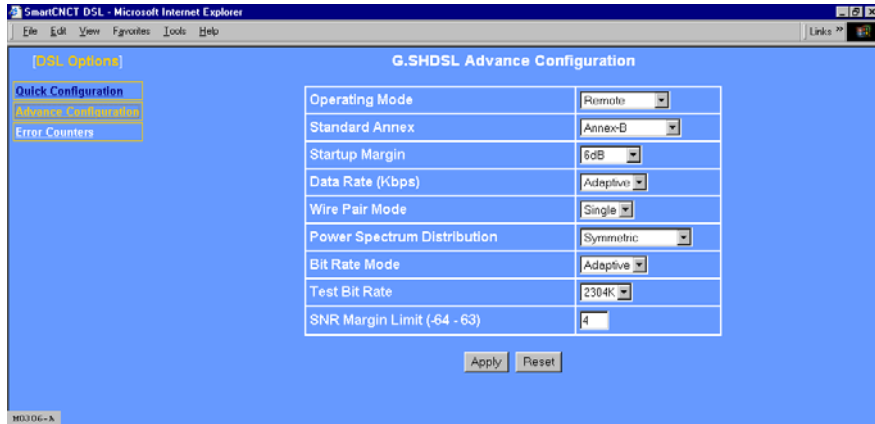

- 2 In the **Operating Mode** box, select **CO** to configure the modem for this mode.
- 3 Click **Apply**.

Configure the Central-Office WAN

- 1 Select **WAN** on the menu bar to access the **WAN Configuration** page.

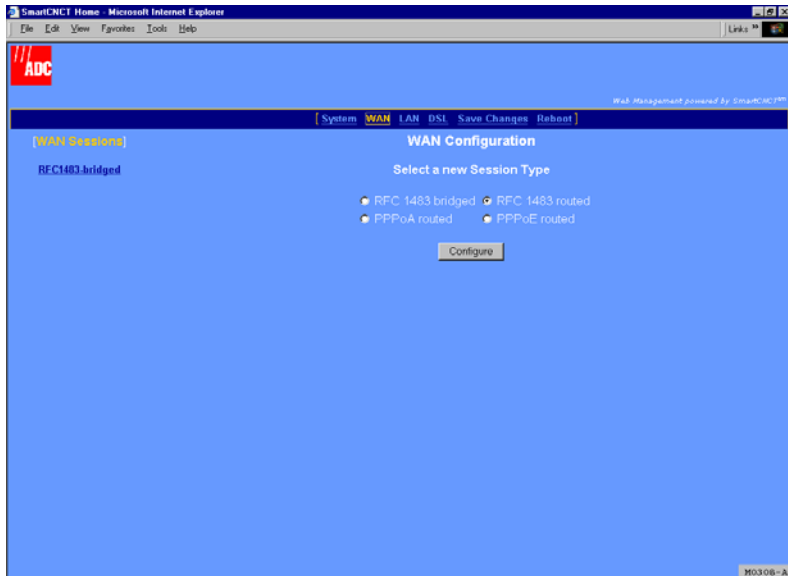

- 2 Select **RFC 1483 bridged** from the **WAN Configuration** page to display the following page.

The screenshot shows a web browser window displaying the ADC (Advanced Configuration and Control) interface. The page title is "RFC1483 Bridged Session". The interface includes a navigation menu with "System", "WAN", "LAN", "DSL", "Save Changes", and "Reboot". The main content area contains a form for configuring the session. The form fields are as follows:

Session Name	<input type="text" value="bonding_only"/>
Virtual Path ID (VPI 0 - 4,095)	<input type="text" value="0"/>
Virtual Channel ID (VCI 32 - 65,535)	<input type="text" value="35"/>
ATM QoS	<input type="text" value="UBR"/>
QoS Peak Cell Rate	<input type="text" value="2000"/>
QoS Sustainable Cell Rate	<input type="text" value="0"/>
QoS Maximum Burst Size	<input type="text" value="0"/>
Encapsulation	<input type="text" value="L2: Bridged"/>

Below the form is a "Create" button. The browser's status bar at the bottom shows "Done" and "800.048.P-A".

- 3 In the **Session Name** box, assign a name to this session (it can be the same name set up for the Remote modem).
- 4 In the **Virtual Path ID (VPI 0 - 4,095)** box, enter the Virtual Path ID. This must match the Virtual Path ID of the Remote modem.
- 5 In the **Virtual Channel ID (VCI 32 - 65,535)** box, enter the Virtual Channel ID. This must match the Virtual Channel ID of the Remote modem.
- 6 Click **Apply**.

Configure the Central-Office LAN

- 1 Select **LAN** on the menu bar, then select **LAN Setup** under **LAN Options**] to access the **LAN Configuration** page.

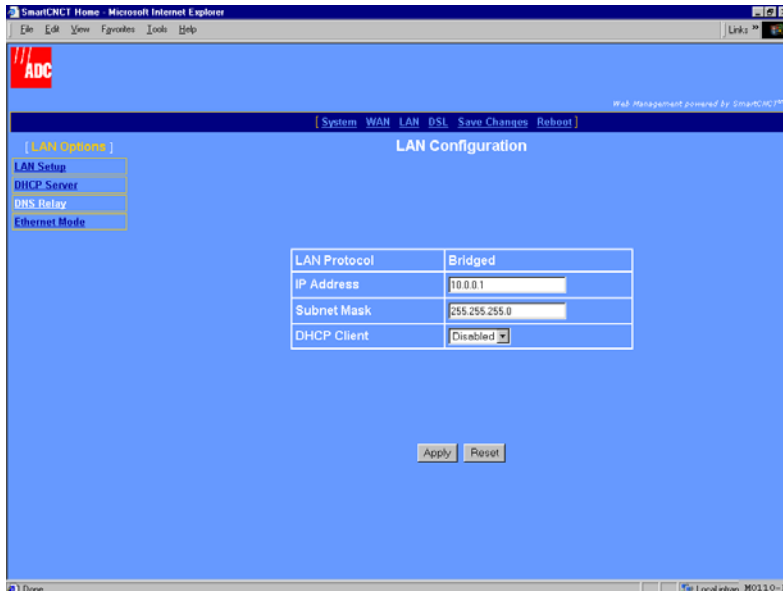

- 2 In the **LAN Protocol** box, confirm that the protocol is set to **Bridged**. If the protocol is not set to bridged, it can be changed only through the command-line interface. See [Appendix A, “Accessing the Command-Line Interface”](#) for procedures on using this interface to change the LAN protocol.



Any device (such as a PC) connecting to the modem LAN interface loses its connection when the modem LAN IP address is changed. After the IP address is changed, you need to specify this new address in the Web browser to reconnect a device.

- 3 In the **IP Address** box, enter an available IP address on your subnet.
- 4 Click **Apply**.

- 5 Select **Save Changes** on the menu bar to access the **Save Changes** page.

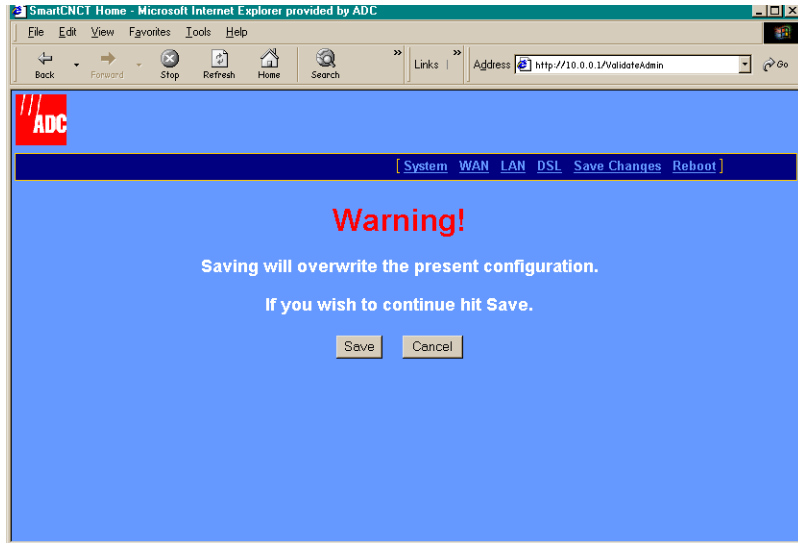

- 6 Click **Save** to save the configuration to flash memory.

VERIFY CONNECTIVITY

After you have performed each of the previous configuration changes, verify back-to-back communication by passing traffic over the WAN session. For example, set up a PC on the LAN-side of the Remote modem and another PC on the LAN-side of the Central-Office modem. Then, transfer a file or ping between the two PCs. This generates traffic and tests connectivity.

- 1 On the front panel of one of the modems, check the status of the SYNC LED. If it is blinking, it is attempting to establish communication with the other modem. If it is on solid green, it has already synchronized its connection with the other modem. See “[LED Status Indications](#)” on page 5 for further definitions of LEDs indications.
- 2 Select **System** on the menu bar, then select **ATM Statistics** under [Status] to access the **ATM Statistics** page.

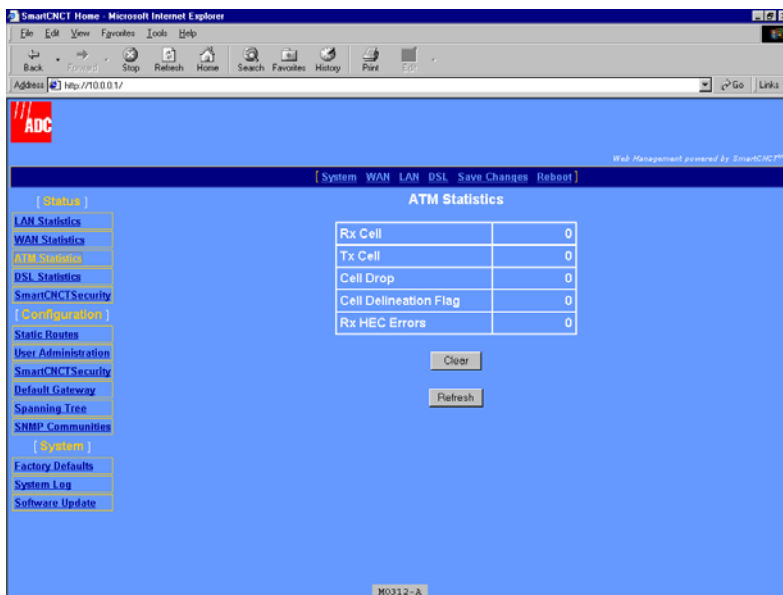

- 3 View the statistics. If the RX Cell and TX Cell values increment, the two modems have established communication and are passing traffic. If they do not, refresh the page by clicking the **Refresh** button on your Web browser. If the counters still do not increment, verify each modem for the correct configuration parameters.

CONFIGURING MODEM SECURITY

8

SmartCNCT Security provides both firewall and security features for the modem, protecting it from unwanted intrusion. NAT, which is part of security, is the only SmartCNCT Security feature available this release.



SmartCNCT Security, except NAT, is not supported in this release. Although the Web interface has configuration for this features, do not change any settings other than those for NAT that are covered in this chapter.

BEFORE YOU BEGIN. . .

Set up WAN sessions. These sessions provide the external interface (public WAN IP address) to which NAT is bound.

CONFIGURE NAT

NAT provides the ability to map private IP address on the LAN to public IP addresses (WAN) that are assigned to each session.

This essentially hides the private IP addresses behind the public IP addresses assigned to WAN sessions. Prior to binding NAT to a WAN IP address, you should have previously set up PPPoA routed, PPPoE routed, or RFC 1483 routed WAN sessions (see “Configure a New WAN Session” on page 26). You cannot configure NAT for RFC 1483 bridged sessions.

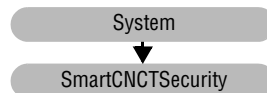

- 1 Select **System** on the menu bar, then select **SmartCNCTSecurity** under **[Configuration]** to access the **Security Interface Configuration** page.

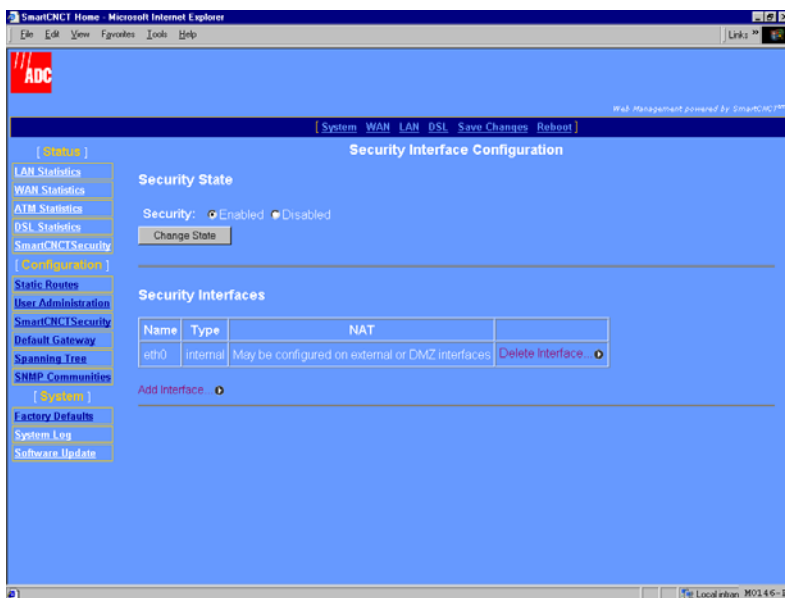

- 2 Select **Add Interface**, which is a link below the **Security Interfaces** table, to display the **Firewall Add Interface** page.



In the **Session Name to Interface Mapping** table, the **Session Name** is the name you assigned to a session during configuration. The **Interface** is the protocol type selected for that session and corresponds to the **Name:** field at the top of the page. NAT is attached to this session which is an external (WAN) interface.

- 3 In the **Name** box, select the session (interface from the **Session Name to Interface Mapping** table shown on page 78) as the external interface to which NAT is bound.
- 4 In the **Interface Type** box, select **external**.
- 5 Click **Apply** and you automatically return to the **Security Interface Configuration** page.
- 6 To bind this session with NAT to internal interfaces (private LAN-side IP addresses), click the button **Enable NAT to internal interfaces** located in the **NAT** column in the **Security Interfaces** table. To disable the binding of this session with NAT to internal interfaces, click the button **Disable NAT to internal interfaces** located in the **NAT** column in the **Security Interfaces** table.

MANAGING THE MODEM

9

This chapter provides information and procedures to assist you in the fault management and maintenance of the modem, including the following.

- Summary of the modem status (from the System page) provides valuable information to manage and troubleshoot the modem.
- Summary of DSL performance provides DSL error counters and DSL link statistics.
- **Factory Default** parameter provides the capability to return the modem from a current configuration to known default parameters.
- **System Update** parameter provides the capability of downloading a configuration file or a software file (for upgrades or restoration) to the modem.

VIEW SYSTEM STATUS

System status provides an overall management view of the modem configuration and performance. The system page, which also functions as the Web interface home page, provides a management view of modem configuration. A system log shows errors that have occurred during the time frame that the modem has been in service.

View Modem Status

The **System Status** page is a read-only summary of the current modem configuration. It includes information about the modem software, DSL configuration values, WAN session settings, and LAN parameters. Use it as an overview of the modem status.

System

The screenshot shows the ADC modem web interface. The browser address bar displays `http://144.16.192.31`. The page title is "ADC" and the sub-header is "Web Management powered by SmartCNC™". The navigation bar includes "System", "WAN", "LAN", "DSL", "Save Changes", and "Reboot".

System

Device Name: Branch Router
 Firmware Release: 2.1.12.2
 Model: MM701G
 MAC Address: 00:20:A7:A2:26:E0
 DSP Version: R1.7 -5

Summary of current settings

DSL Status		WAN Session: research_group2		LAN	
Modulation	Annex-B	Protocol	RFC 1483 Routed	Protocol	Bridged
State	ShowTime	IP Address	192.146.100.100	IP Address	144.16.192.31
Trans Rate Tx	2312 Kb	Net Mask	255.255.255.0	Net Mask	255.255.240.0
Data Rate Rx	2312 Kb	VPI	28	SNCP Mode	None
SNR Margin	14 dB	VCI	1200	DSL Picky	Disabled

The following is a description of the fields at the top of the **Status** page:

Device Name

Identifies the modem and its LAN connection type (Ethernet port). This is not a configurable parameter.

Firmware Release

Identifies the version number of the software image currently used on the modem.

Model

Identifies the model of the modem.

MAC Address

Identifies the unique, hardware address assigned to and resident on the modem.

DSP Version

Identifies the version of the G.shdsl firmware driver used for the modem.

The following is a description of the fields in the **Summary of current settings** table:

DSL Status

Provides configuration values specific to G.shdsl, including:

- **Modulation**—Indicates the G.shdsl transmission standard to which the modem is set.
- **State**—Status of the DSL link.
- **Data Rate TX**—Bit rate at which the is configured to send data.
- **Data Rate RX**—Bit rate at which the is configured to receive data.
- **SNR Margin (DB)**—Current SNR margin in decibels.

WAN Session

See [“Configure a New WAN Session” on page 26](#) for definitions of **WAN Session** fields.

LAN

See [“Configure the LAN” on page 14](#) for definitions of **LAN** fields.

View System Log

The **Configuration Error Log** shows errors that have occurred during the time the modem is operational. This error log is used by the manufacturer for internal use only.

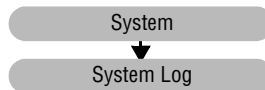

Select **System** on the menu bar, then select **System Log** under **[System]** to access the **Configuration Error Log** page.

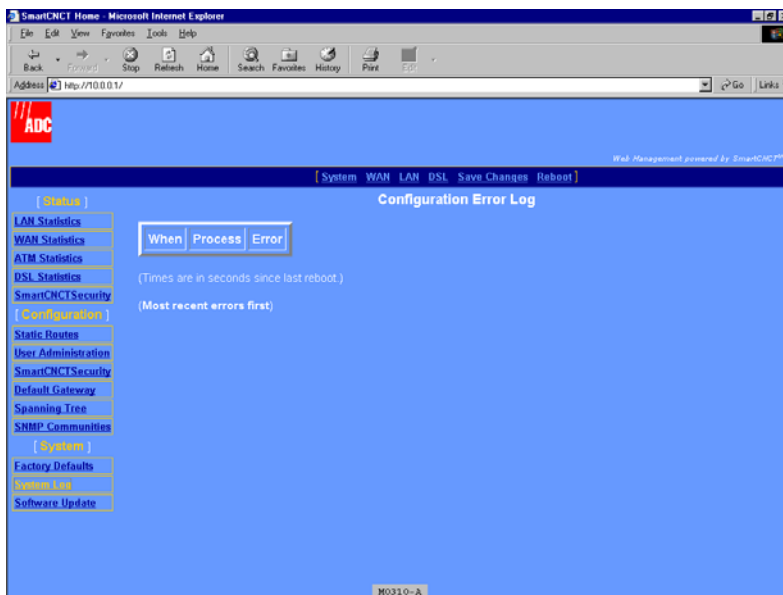

VIEW WAN STATISTICS

WAN Statistics provide information about packets received and transmitted for every WAN session configured for the modem.

- 1 Select **System** on the menu bar, then select **WAN Statistics** under [Status] to access the **WAN Statistics** page.

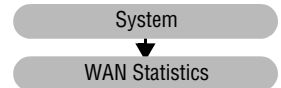

The screenshot shows a web browser window displaying the SmartCMCT web management interface. The page title is "WAN Statistics". The interface includes a navigation menu on the left with options like LAN Statistics, ATM Statistics, DSL Statistics, SmartCMCTSecurity, Static Routes, User Administration, SmartCMCTSecurity, Default Gateway, Spanning Tree, SHMP_Communities, System, Factory Defaults, System Log, and Software Update. The main content area displays a table with the following data:

Session Name	Rx Pkts	Rx Bad Pkts	Tx Pkts	Tx Bad Pkts
bidg4_int				
research_group2	0	0	38	38
RFC1483-bridged	0	0	189	0

- 2 View the current statistics as described below:

Session Name

Identifies the session name, for up to 32 sessions, for which the transmitted and received packets are being reported.

Rx Pkts

The total number of packets received for this session.

Rx Bad Pkts

The total number of errored packets received for this session.

Tx Pkts

The total number of packets transmitted for this session.

Tx Bad Pkts

The total number of errored packets transmitted for this session.

VIEW LAN STATISTICS

LAN Statistics provide information about packets received and transmitted for every WAN session configured for the modem.

- 1 Select **System** on the menu bar, then select **LAN Statistics** under [Status] to access the **LAN Statistics** page.

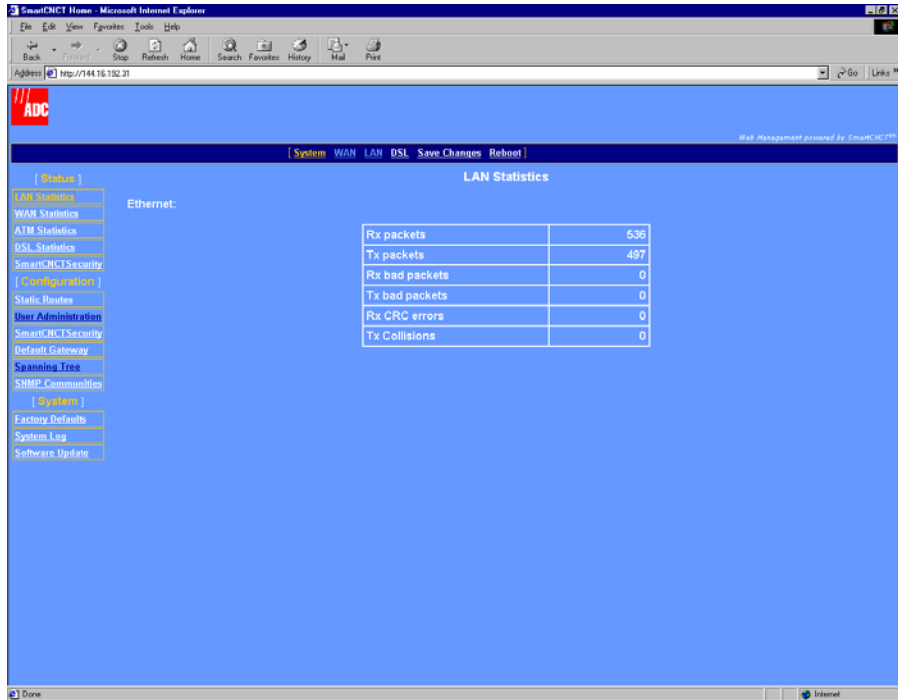
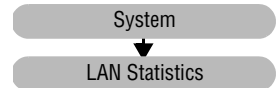

- 2 View the current statistics as described below. The statistics are provided for a connection to the Ethernet port.

Rx Pkts

The total number of Ethernet packets received on this port.

Tx Pkts

The total number of Ethernet packets transmitted on this port.

Rx Bad Pkts

The total number of errored Ethernet packets received on this port.

Tx Bad Pkts

The total number of errored Ethernet packets transmitted on this port.

Rx CRC Errors

The total number of Cyclic Redundancy Code (CRC) errors received for Ethernet packets on this port.

Tx Collisions

The total number of collisions occurring between devices attempting to transmit Ethernet packets on this port.

VIEW SMARTCNCT SECURITY STATISTICS

The **Security Status** page provides information about SmartCNCTSecurity that is configured for the modem. This status page will show default values only because SmartCNCTSecurity is not supported for this release.

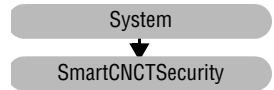

SmartCNCTSecurity, except NAT, is not supported in this release.

- 1 Select **System** on the menu bar, then select **SmartCNCTSecurity** under **[Status]** to access the **Security Status** page.

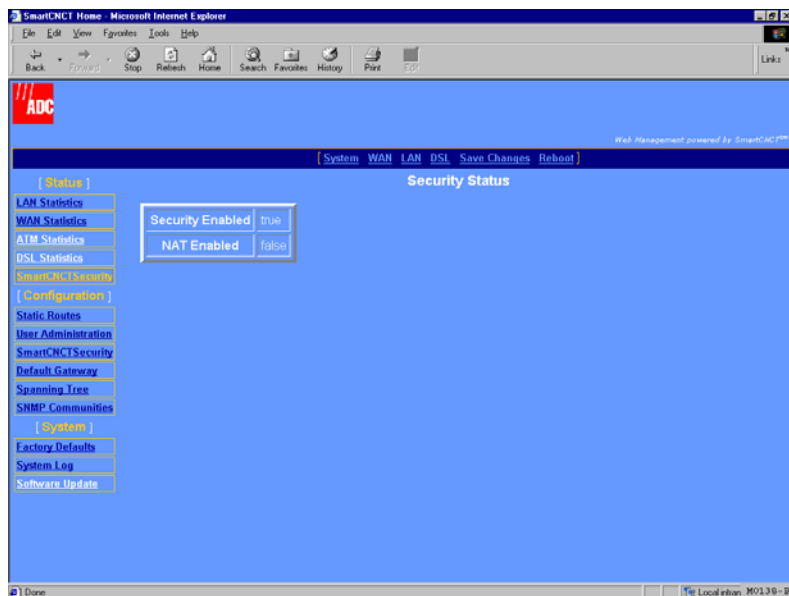

- 2 View the current statistics as described below:

Security Enabled

True indicates that security is enabled. False indicates that security is not enabled.

NAT Enabled

True indicates that NAT is enabled. False indicates that NAT is not enabled.

VIEW ATM STATISTICS

The **ATM Statistics** page provides information about the cells that are transmitted on the ATM layer.

System

ATM Statistics

- 1 Select **System** on the menu bar, then select **ATM Statistics** under **[Status]** to access the **ATM Statistics** page.

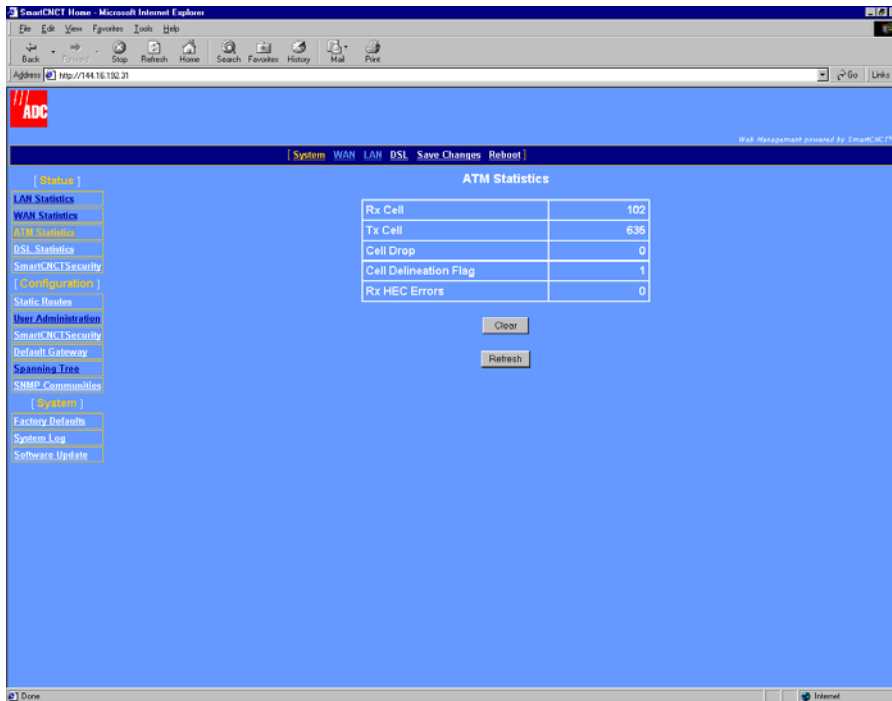

- 2 View the current statistics as described below.

Rx Cell

Indicates the total number of cells received by the modem on the DSL interface.

Tx Cell

Indicates the total number of cells transmitted by the modem over the DSL interface.

Cell Drop

Indicates the total number of cells dropped by the modem.

Cell Delineation Flag

Indicates if cell delineation errors have occurred on the modem. A **0** indicates that no errors have occurred A **1** indicates that errors have occurred.

Rx HEC Errors

Indicates the total number of received ATM cells marked with uncorrectable header errors as indicated in the header-error control (HEC) byte.

3 Click one of the following, if appropriate:

- **Clear**—resets all the counters to zero.
- **Refresh**—updates the page with more current error counts.

VIEW DSL STATISTICS

The DSL statistics provides link statistics as well as error counter values for the modem. This data provides information for managing and troubleshooting the DSL transmission.



Use the console port interface to access embedded DSL diagnostics. See “[Manage DSL](#)” on page 118.

View G.shdsl Link Statistics

Use the information about the G.shdsl transmission on the Link Statistics page for troubleshooting and monitoring.

- 1 Select **System** on the menu bar, then select **DSL Statistics** under [Status] to access the **Link Statistics** page.

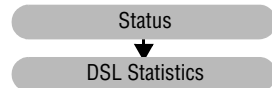

The screenshot shows the SmartCNCT web interface in Microsoft Internet Explorer. The address bar shows <http://144.16.192.31>. The page title is "SmartCNCT Home - Microsoft Internet Explorer". The main content area is titled "Link Statistics" and contains a table with the following data:

Operational State	ShowTime
Data Rate	2312 Kbps
DSP Version	R1.7-6
Transmission Power	8
Receiver Gain	7
Local SNR Margin	14
Loop Attenuation	0
Framer Sync	InSync

The left sidebar contains a menu with the following items: [Online], LAN Statistics, WAN Statistics, ATM Statistics, DSL Statistics, SmartCNCTSecurity, [Configuration], Static Routes, User Administration, SmartCNCTSecurity, Default Gateway, Spanning Tree, SNMP Communities, [System], Factory Defaults, System Log, Software Update.

2 View the current statistics as described below:

Operational State

Indicates the current mode of the modem. Operational states include:

- **handshaking**—indicates that the modem is negotiating with the DSLAM or the other modem
- **training**—indicates that the modem is learning the connection parameters
- **show time**—indicates the G.shdsl connection is operational

Data Rate

Indicates the bit rate for this transmission on the G.shdsl connection.

DSP Version

Indicates the version of G.shdsl firmware driver used on this modem.

Transmission Power

Indicates the local transmission power in decibels.

Receiver Gain

Indicates the amplifying factor for incoming signal in decibels.

Local SNR Margin

Indicates the actual value for the SNR margin.

Loop Attenuation

Indicates the current and approximate loop attenuation (loop signal loss) in decibels.

Framer Sync

Indicates the current status of G.shdsl frame synchronization.

View G.shdsl Error Counters

Use the statistics on the **G.SHDSL Error Counters** page for troubleshooting and monitoring G.shdsl transmission.

- 1 Select **DSL** on the menu bar, then select **Error Counters** under **[DSL Options]** to access the **G.SHDSL Error Counters** page.

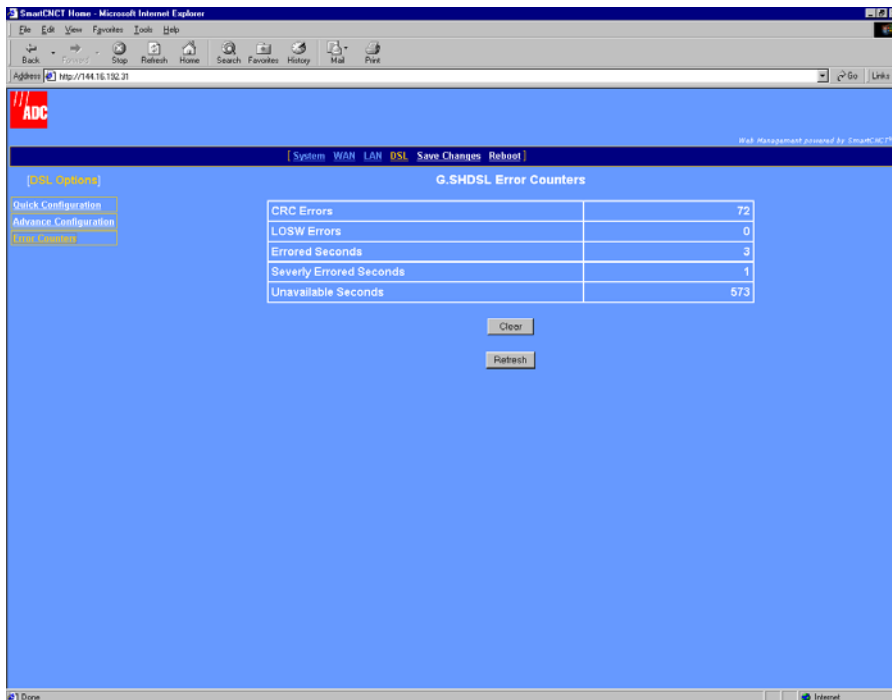
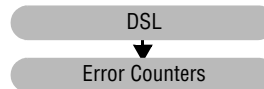

- 2 View the current statistics as described below:

CRC Errors

Indicates the total number of cyclic redundancy check (CRC) errors that have occurred on the G.shdsl connection since the last time that the G.shdsl error counters were cleared. CRC is an error checking technique used to ensure the integrity of data during transmission.

LOSW Errors

Indicates the total number of loss of sync word (LOSW) defects that have occurred since the last time that the G.shdsl error counters were cleared. An LOSW is indicated when three or more consecutive frames contain one or more bit errors in the frame sync word.

Errored Seconds

Indicates the total number of seconds in which one or more CRC errors occurred since the last time that the G.shdsl error counters were cleared.

Severely Errored Seconds

Indicates the total number of seconds in which 50 or more CRC errors occurred since the last time that the G.shdsl error counters were cleared.

Unavailable Seconds

Indicates the total number of seconds that the G.shdsl connection has been non-operational due to loss of synchronization or excessive errors since the last time that the G.shdsl error counters were cleared.

3 Click one of the following:

- **Clear**—resets all the counters to zero.
- **Refresh**—updates the page with current error counts.

MANAGE SOFTWARE AND CONFIGURATION

Update System Software

Using the Web interface HTTP Upgrade capability, you can upgrade the software (.bin) and http files on your modem. To complete an upgrade, specify the IP address of a server on the LAN side of modem where the new firmware is stored.

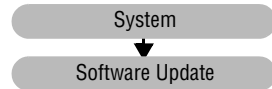

The software update process takes about 90 seconds to complete and after the update the modem resets itself. Do not recycle the power during this process. This will cause permanent image corruption.

It is strongly recommended that you use this procedure to upgrade software rather than upgrading through a telnet session or through the Console port.

- 1 Click **System** on the menu bar, then **Software Update** under [System] to access the **Software Update** page.

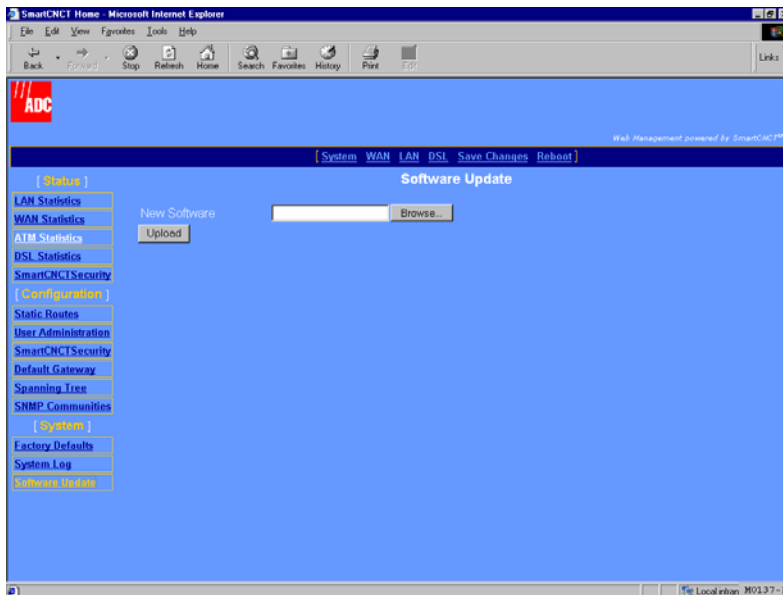

- 2 Click **Browse**, locate the server on the LAN where the firmware image or configuration file is located, then click **Open**.

- 3 Click **Upload** to start the file transfer to the modem.



Do not power cycle the modem when the software update is in progress. Wait for the Flash Update Complete message before power cycling the modem.

- 4 Click **Update Flash** when prompted.
- 5 Click **Restart** when prompted.

Reset to Factory Defaults

When you configure the modem, you change the factory default settings to new values. You can return these parameters to their default values to provide a known starting point if you are troubleshooting or if you simply want to configure new parameters. For session default values, see “Default Session Parameter Values” on page 140.

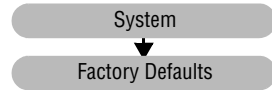

Active links are lost when you reset to factory default values.

- 1 Click **System** on the menu bar, then **Factory Defaults** under **[System Options]** to access the **System Factory Defaults** page.

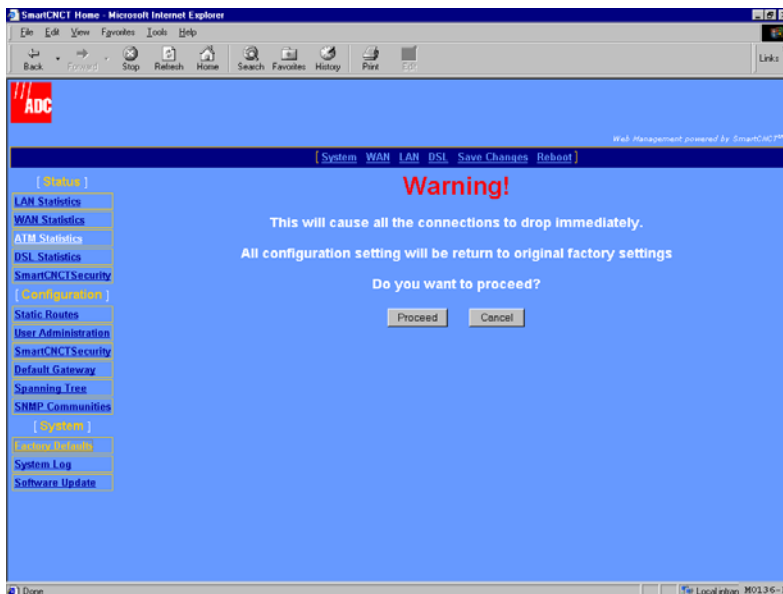

- 2 Click **Proceed** if you want to return all modem parameters to their original factory values. Click **Cancel** if you do not want to return all modem parameters to their original factory values.

ACCESSING THE COMMAND-LINE INTERFACE



You can manage the modem using either the command-line interface or the Web interface. Access to the command-line interface is accomplished by either direct connection to the modem console port or through a telnet session (over a network). This section provides instructions for accessing and using the command-line interface. Access to the Web interface is accomplished through a Web browser using an internet connection. [Chapter 2, “Accessing the Web Interface for Modem Management”](#) provides instructions on accessing and using the Web interface for management.

The Web interface is the more comprehensive of the two management interfaces and generally simpler to use. There are situations, however, in which using the command-line interface is preferred over the Web interface. For example, if you cannot connect to the modem through the DSL line and 10Base-T port, you can still manage the modem through the console port.

The following sections describe how to use the command-line interface:

Section	Page
Connect to the Console Port	100
Access through a Telnet Session	103
Manage WAN Sessions	106
Manage DSL	118
Restoring Factory Defaults	130
Saving the Current Configuration	131
Updating System Software	132
Viewing System Information	133
Rebooting the Modem	134

CONNECT TO THE CONSOLE PORT

- 1 Install the flat gray console cable between the modem Console port and your PC as shown below, using the DB-9 port adapter on the PC, if required.

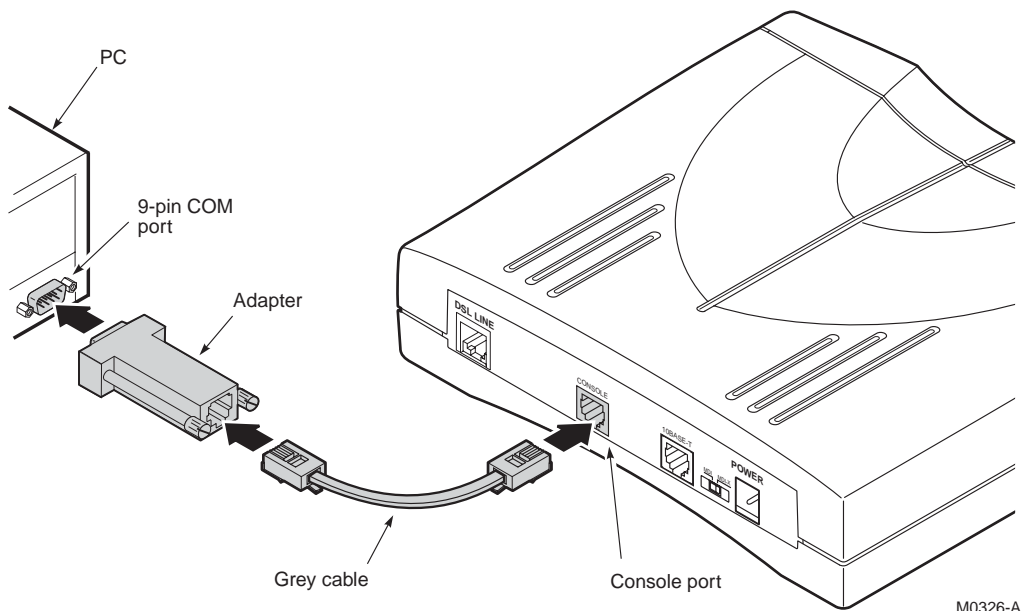

ACCESS THE COMMAND-LINE INTERFACE

You can access the command-line interface through the direct connection to the modem console port and using a terminal emulation program. You can also access the command-line interface using a telnet session. To use a telnet session, you must have IP access to the modem either through the 10Base-T LAN port (LAN-side access) or through an IP address assigned to a WAN session (WAN-side access). The following sections provide instructions for setting up both types of command-line interface access.

Access through the Console Port

Access the terminal emulation program (HyperTerminal, for example) to establish a connection to the modem command-line interface. The following procedure uses HyperTerminal as the example terminal emulation program. If you are using another terminal emulation program, refer to the user documentation for instructions.

- 1 From the **Start** button, select **Programs, Accessories, HyperTerminal**.
- 2 In the HyperTerminal dialog, select **File, New Connection**.
- 3 Enter a name for this connection and click **OK**.
- 4 For **Connect using**, select the COM port (typically COM1) on the PC to which you have connected the modem (console port connection), then click **OK**. The **COM1 Properties** dialog is displayed.

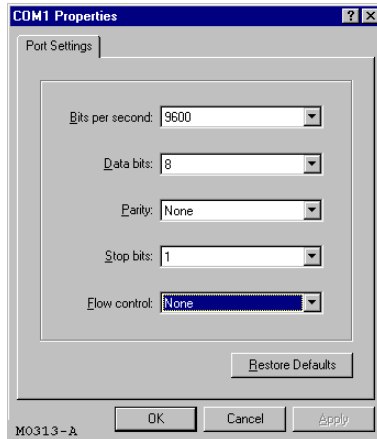

- 5 In the **COM1 Properties** dialog, enter the **Port Settings** as follows:
 - 9600 baud
 - 8 data bits
 - no parity
 - 1 stop bit
 - flow control off (none)
- 6 Click **OK**.

- Press **ENTER**. A prompt will be displayed; enter your login and password.

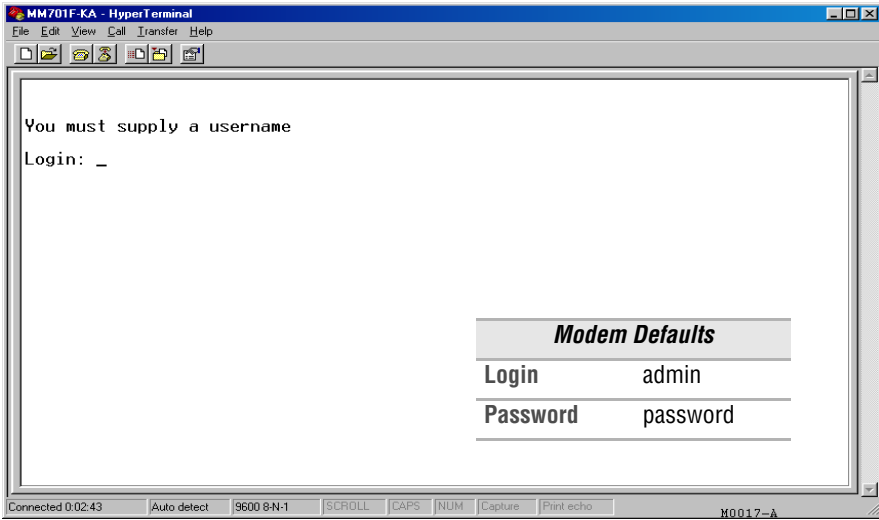

The **System Management** main menu is displayed.

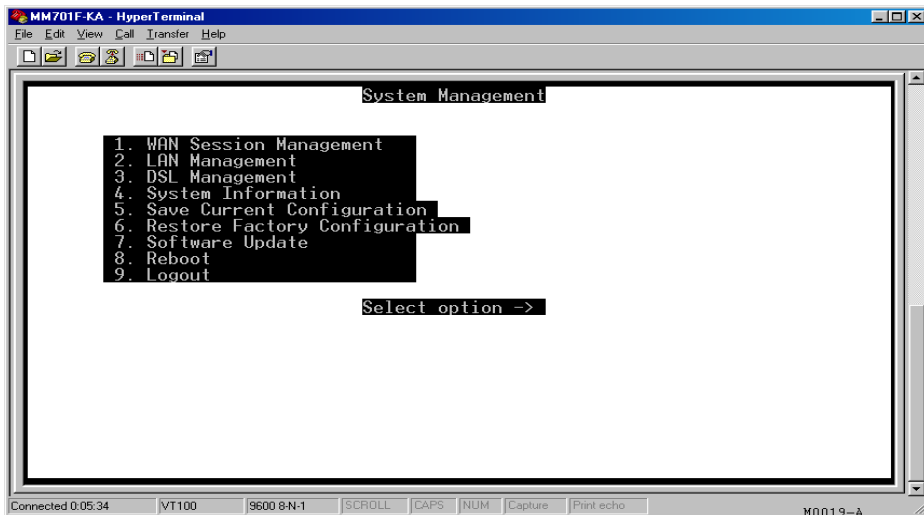

Type the number and press enter to access the configuration menu for each parameter (WAN Session Management or LAN Management, for example). Press enter (<CR>) at the prompt to return to a higher-level menu.

Access through a Telnet Session

To access the modem through a LAN-side telnet session, ensure that the management PC is on the same IP subnet as the modem (see “[Accessing the Web Interface for Modem Management](#)” on page 7); you will specify the LAN port IP address (default LAN IP address is 10.0.0.1 and subnet mask is 255.255.255.0) for access. To access the modem through a WAN-side telnet session, ensure that at least one WAN session has been set up for the modem; you will specify the IP address set up for that WAN session for access.



Although you can have concurrent telnet and console port sessions to the command-line interface, you can make changes through only one of the interfaces at a time.

Below is an example using the telnet application in Microsoft Windows 98 SE to access the modem command-line interface:

- 1 From the **Start** button, select **Run** to display the **Run** dialog. Or, open your telnet application

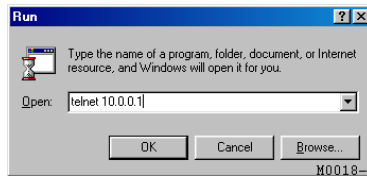

- 2 In the **Open** box, enter the **telnet** command and the modem IP address (for example, 10.0.0.1), then click **OK**. The Windows telnet dialog is displayed.

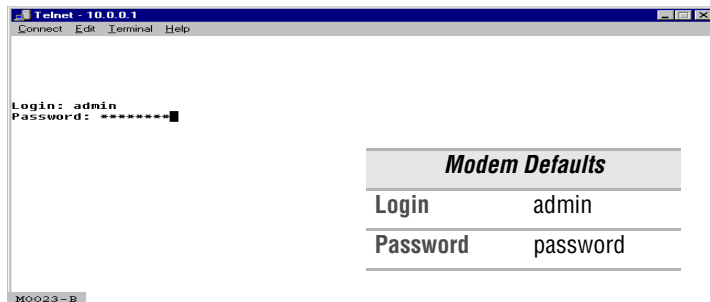

- 3 At the prompt, enter your **Login** and **Password**. The **System Management** main menu is displayed.

SET UP THE LAN

If you are operating in Router mode and in a LAN environment, then you also need to set your LAN protocol, Ethernet Port IP address, and subnet mask.

If you prefer, you may use the default values of **10.0.0.1** for the Ethernet Port IP Address, and **255.255.255.0** for the subnet mask.

- 1 From the **System Management** main menu (page 102), enter **2** to display the **LAN Configuration** menu.

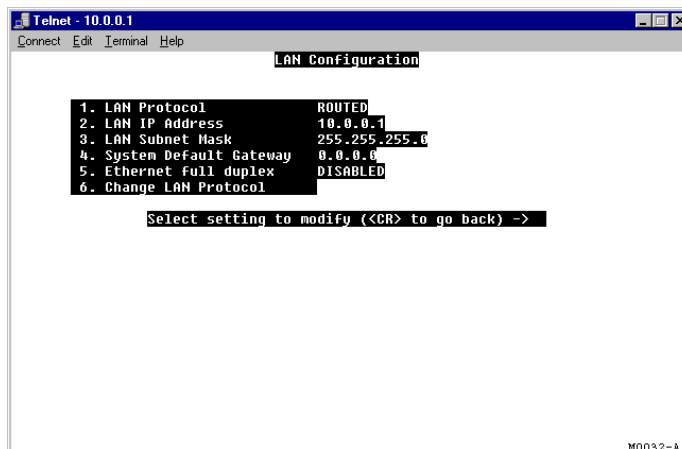

```

Telnet - 10.0.0.1
Connect Edit Terminal Help

LAN Configuration

1. LAN Protocol          ROUTED
2. LAN IP Address       10.0.0.1
3. LAN Subnet Mask     255.255.255.0
4. System Default Gateway 0.0.0.0
5. Ethernet full duplex DISABLED
6. Change LAN Protocol

Select setting to modify (<CR> to go back) ->
M0032-A

```

- 2 Configure the following parameters, 1 through 6, for the PPP session:

LAN Protocol

Enter **1** then select one of the following for DHCP protocol:

- **1—Spanning Tree** where you select **1** to **Disable** spanning tree protocol or select **2** to **Enable** spanning tree protocol for all bridging sessions.



If a DHCP server is not set up and active on your LAN, do not enable DHCP client. DHCP Client mode is recommended for use only when bridging is used as the LAN protocol.

- **2—DHCP Client mode** where you select **1** to **Disable** DHCP client mode or select **2** to **Enable** DHCP client mode for the modem.

LAN IP Address

Enter **2** then type the IP address provided by your LAN administrator. Use the following criteria to determine if or how the LAN IP address will be changed:

- Enter an IP address for the LAN (10Base-T) port provided by the LAN administrator if you are not implementing a 10.0.0.0 subnet.
- Use the default IP address for the LAN port which is 10.0.0.1. If you choose to use the default IP address, ensure that the devices on your LAN are on the same subnet as this modem LAN port.
- If you want a DHCP server on your LAN to automatically provide the modem LAN port IP address, select **Client** for the DHCP configuration (configuration step is on [page 104](#)).

LAN Subnet Mask

Enter **3** then type the LAN subnet mask provided by your LAN administrator. Use the following criteria to determine if or how the LAN subnet mask will be changed:

- Enter the subnet mask for the LAN (10Base-T) port provided by the LAN administrator.
- Use the default subnet mask for the LAN port which is 255.255.255.0. If you choose to use the default subnet mask, ensure that it allows devices on your LAN to access the modem LAN port.
- If you want a DHCP server on your LAN to automatically provide the subnet mask in addition to the IP address, select **Client** for the DHCP configuration (configuration step is on [page 104](#)).

System Default Gateway

Enter **4** then type the IP address of the DHCP default gateway that is provided by the LAN administrator for devices on the LAN. After you configure this IP address, the modem provides this IP address as a default DHCP gateway to requesting DHCP clients (such as PCs) on the LAN. If there are no gateways on the LAN, then the modem LAN port IP address can be assigned as the gateway.

Ethernet Full Duplex

Enter **5** then select **2** for **Enabled** if you want to set the modem LAN port to full-duplex transmission. Select **1** for **Disabled** (default) if you want to set the modem LAN port to half-duplex.

Change LAN Protocol

Enter **6** then select one of the following to change the LAN Protocol:

- **1—Bridging protocol**
 - **2—Routing protocol**
- 3** Select **Save Current configuration** from the Main Menu as described in “[Saving the Current Configuration](#)” on page 131 or the changes will be lost upon reboot or power cycle.

MANAGE WAN SESSIONS

From the **System Management** main menu ([page 102](#)), enter **1** to display the **WAN Session Management** menu. The WAN Session Management screen displays the available options.

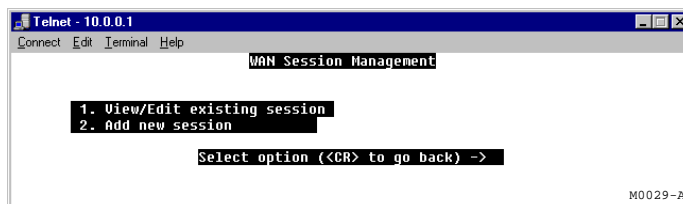

A total of 32 WAN sessions can be created using the protocols listed below. Ensure, however, that you do not exceed the maximum limit per protocol type as shown below:

- RFC 1483-Bridge (up to 8 sessions)
- RFC 1483-Router (up to 16 sessions)
- PPPoA or PPPoE (up to 8 sessions for either type)

Add a New Session

- 1 On the **WAN Session Management** menu, enter **2** to add a new session. The **Create new session** menu is displayed.

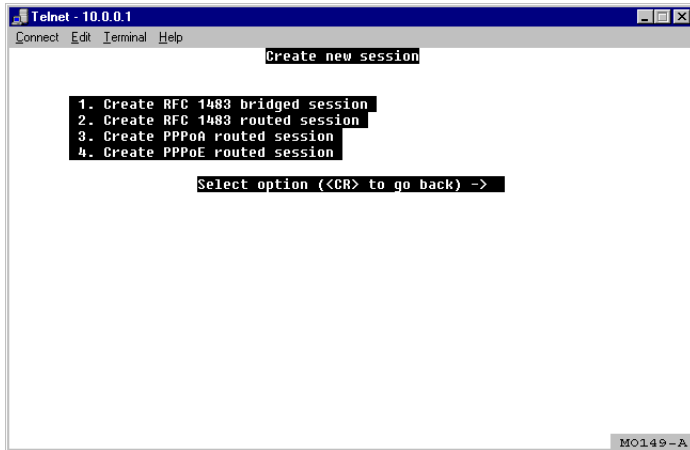

- 2 Select one of the following protocols for this session:
 - **1—Create RFC 1483 bridged session** if the modem forwards packets based on MAC addresses. You can enable Spanning Tree when you select Bridge sessions. See [“Change Spanning Tree Setting” on page 51](#).
 - **2—Create RFC 1483 routed session** if the modem routes packets based on IP addresses.
 - **3—Create PPPoA routed session** if the modem establishes PPP sessions over ATM with the service provider and routes packets based on IP addresses.
 - **4—Create PPPoE routed session** if modem establishes PPP sessions over Ethernet with the service provider and routes packets based on IP addresses.

Set Up an RFC 1483 Bridged Session

You selected **Create RFC 1483 bridged session** from the **WAN Session Management** menu to display the following menu.

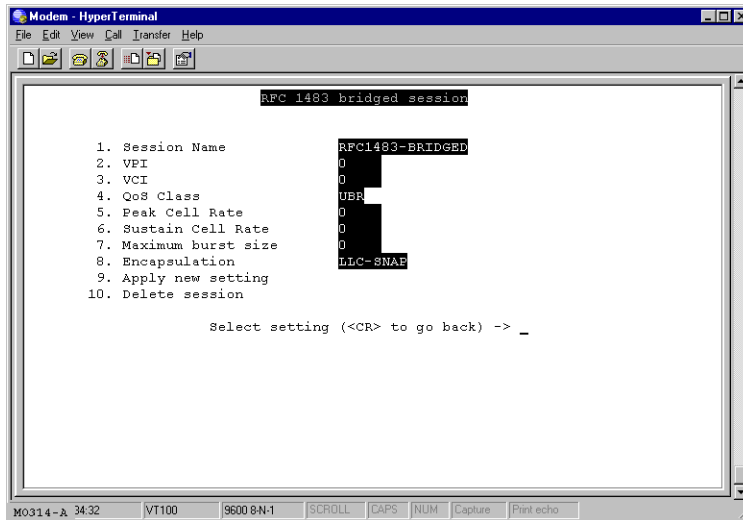

1 Configure the following parameters, 1 through 8, for the bridging session:

Session Name

Enter **1** then type a unique, descriptive identifier for the session. This name can have a maximum of 32 characters.

Virtual Path ID (VPI)

Enter **2** then type the value (from 0 to 4,095) provided by the service provider. The number identifies the virtual path that transports ATM cells between the modem and the service provider. This value must match the virtual path identification (VPI) value the service provider uses for this connection.

Virtual Channel ID (VCI)

Enter **3** then type the value (from 32 to 65,535) provided by the service provider. The number identifies the virtual channel for this session that transports ATM cells between the modem and the service provider. This value must match the virtual channel identification (VCI) value the service provider uses for this connection.

QoS Class

Enter **4** then select the ATM Quality of Service indicated by your service provider. The options are:

- **1—CBR** (constant bit rate)
- **2—VBR-rt** (variable bit rate real-time)
- **3—VBR-nrt** (variable bit rate non-real-time)
- **4—UBR** (unspecified bit rate is the default setting)

Peak Cell Rate

Enter **5** then type the QoS Peak Cell Rate (PCR) value supplied by your service provider. If you are not provided a PCR value, use the default. PCR is the maximum rate at which data is transferred on the line and measured in ATM cells per second. The valid range is 1-5500 cells per second. The default PCR is 5500.

Sustain Cell Rate

Enter **6** then type the QoS Sustainable Cell Rate (SCR) value supplied by your service provider. Use for CBR, VBR-rt, and VBR-nrt ATM QoS. SCR is the average rate at which ATM cells are transferred, measured in cells per second. The SCR must be less than the PCR. The valid range is 1-5500 cells per second.

Maximum burst size

Enter **7** then type the QoS Maximum Burst Size (MBS) value supplied by your service provider. Use with VBR-rt and VBR-nrt QoS. MBS is the maximum number of cells that can be transmitted at the peak cell rate. The MBS rate must be equal to or less than the PCR. The default MBS is 0.

Encapsulation

Enter **8** then select the encapsulation type as indicated by the service provider. The options are:

- **1—Llc Encapsulation** (Logical Link Control) allows multiple protocols to be run over the session. This is the default encapsulation.
- **2—Vcmux Encapsulation** (Virtual Channel Multiplexer) encapsulation allows one protocol to be run over the session.

- 2** Enter **9** to **Apply new setting** to add the new RFC1483 bridged session to your session list. Or, you can Enter **10** to **Delete session**.

Set Up an RFC 1483 Routed Session

You selected **Create RFC 1483 routed session** from the **WAN Session Management** menu to display the following menu.

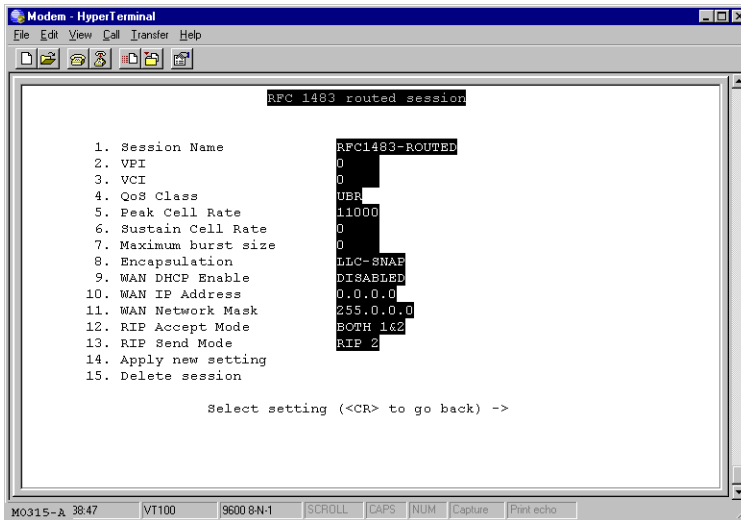

1 Configure the following parameters, 1 through 13, for the routing session:

Session Name

Enter **1** then type a unique, descriptive identifier for the session. This name can have a maximum of 32 characters.

Virtual Path ID (VPI)

Enter **2** then type the value (from 0 to 4,095) provided by the service provider. The number identifies the virtual path that transports ATM cells between the modem and the service provider. This value must match the virtual path identification (VPI) value the service provider uses for this connection.

Virtual Channel ID (VCI)

Enter **3** then type the value (from 32 to 65,535) provided by the service provider. The number identifies the virtual channel for this session that transports ATM cells between the modem and the service provider. This value must match the virtual channel identification (VCI) value the service provider uses for this connection.

QoS Class

Enter **4** then select the ATM Quality of Service indicated by your service provider. The options are:

- **1—CBR** (constant bit rate)
- **2—VBR-rt** (variable bit rate real-time)
- **3—VBR-nrt** (variable bit rate non-real-time)
- **4—UBR** (unspecified bit rate is the default setting)

Peak Cell Rate

Enter **5** then type the QoS Peak Cell Rate (PCR) value supplied by your service provider. If you are not provided a PCR value, use the default. PCR is the maximum rate at which data is transferred on the line and measured in ATM cells per second. The valid range is 1-5500 cells per second. The default PCR is 5500.

Sustain Cell Rate

Enter **6** then type the QoS Sustainable Cell Rate (SCR) value supplied by your service provider. Use for CBR, VBR-rt, and VBR-nrt ATM QoS. SCR is the average rate at which ATM cells are transferred, measured in cells per second. The SCR must be less than the PCR. The valid range is 1-5500 cells per second.

Maximum burst size

Enter **7** then type the QoS Maximum Burst Size (MBS) value supplied by your service provider. Use with VBR-rt and VBR-nrt QoS. MBS is the maximum number of cells that can be transmitted at the peak cell rate. The MBS rate must be equal to or less than the PCR. The default MBS is 0.

Encapsulation

Type **8** then select the encapsulation type as indicated by the service provider. The options are:

- **1—Llc Encapsulation** (Logical Link Control) allows multiple protocols to be run over the session. This is the default encapsulation.
- **2—Vcmux** (Virtual Channel Multiplexer) encapsulation allows one protocol to be run over the session.

WAN DHCP Enable

Type **9** then select **1** to **Disable** or **2** to **Enable** DHCP client. Enabling DHCP client provides the capability where this session will automatically received an IP address

from the service provider via a DHCP server. If you enable DHCP client, leave the next two fields, WAN IP address and WAN Network Mask, blank. These fields will automatically receive values.

WAN IP Address

Type **10** then enter the IP address provided by the service provider for this session unless you have enabled WAN DHCP. The default IP address is 0.0.0.0.

WAN Network Mask

Type **11** then enter the network mask provided by the service provider for this session unless you have enabled WAN DHCP. The default WAN Network Mask is 0.0.0.0.

RIP Accept Mode

Type **12** then select one of the following:

- **1—No RIP**
- **2—RIP Version 1**
- **3—RIP Version 2**
- **4—RIP Version 1 & 2 (default)**

RIP Send Mode

Type **13** then select one of the following:

- **1—No RIP**
- **2—RIP Version 1**
- **3—RIP Version 2 (default)**
- **4—RIP Version 1 & 2**

- 2** Enter **14** to **Apply new setting** to add the new RFC1483 routed session to your session list. Or, you can Enter **15** to **Delete session**.

Set Up a PPPoA or PPPoE Routed Session

You selected **Create PPPoA routed session** or **Create PPPoE routed session** from the **WAN Session Management** menu to display the following menu. The **PPPoA routed session** configuration is shown below as an example. The configuration parameters for **PPPoE routed session** are identical.

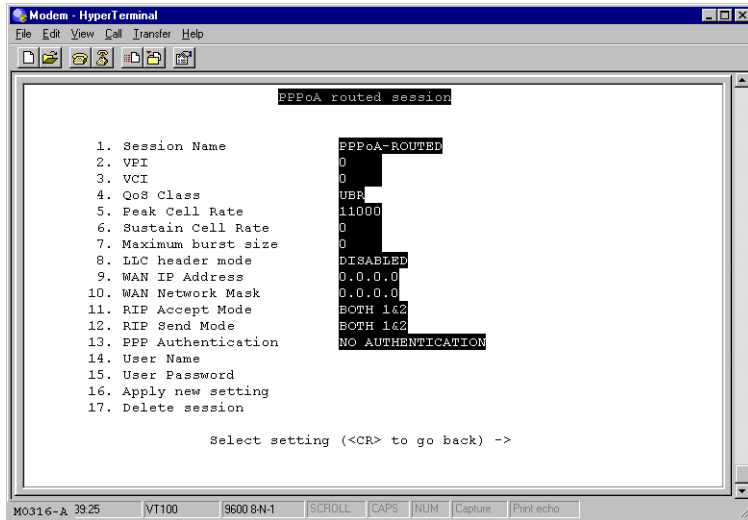

1 Configure the following parameters, 1 through 15, for the PPP session:

Session Name

Enter **1** then type a unique, descriptive identifier for the session. This name can have a maximum of 32 characters.

Virtual Path ID (VPI)

Enter **2** then type the value (from 0 to 4,095) provided by the service provider. The number identifies the virtual path that transports ATM cells between the modem and the service provider. This value must match the virtual path identification (VPI) value the service provider uses for this connection.

Virtual Channel ID (VCI)

Enter **3** then type the value (from 32 to 65,535) provided by the service provider. The number identifies the virtual channel for this session that transports ATM cells between the modem and the service provider. This value must match the virtual channel identification (VCI) value the service provider uses for this connection.

QoS Class

Enter **4** then select the ATM Quality of Service indicated by your service provider. The options are:

- **1—CBR** (constant bit rate)
- **2—VBR-rt** (variable bit rate real-time)
- **3—VBR-nrt** (variable bit rate non-real-time)
- **4—UBR** (unspecified bit rate is the default setting)

Peak Cell Rate

Enter **5** then type the QoS Peak Cell Rate (PCR) value supplied by your service provider. If you are not provided a PCR value, use the default. PCR is the maximum rate at which data is transferred on the line and measured in ATM cells per second. The valid range is 1-5500 cells per second. The default PCR is 5500.

Sustain Cell Rate

Enter **6** then type the QoS Sustainable Cell Rate (SCR) value supplied by your service provider. Use for CBR, VBR-rt, and VBR-nrt ATM QoS. SCR is the average rate at which ATM cells are transferred, measured in cells per second. The SCR must be less than the PCR. The valid range is 1-5500 cells per second.

Maximum burst size

Enter **7** then type the QoS Maximum Burst Size (MBS) value supplied by your service provider. Use with VBR-rt and VBR-nrt QoS. MBS is the maximum number of cells that can be transmitted at the peak cell rate. The MBS rate must be equal to or less than the PCR. The default MBS is 0.

LLC header mode

Enter **8** then select either **1** to **Enabled** or **2** to **Disabled** the LLC header. The default is **Disabled**. **Disabled** indicates that VCMux encapsulation is used. **Enabled** indicates that LLC/Snap encapsulation is used.

WAN IP Address

Enter **9** then type the IP address is dynamically served by the service provider for this session. When the modem has received the IP address for this session, it displays the value in this field. Also, the IP address dynamically received for the first PPP session set up is assigned as the default gateway (see [page 44](#)). The default is 0.0.0.0.

If the service provider does not dynamically provide an IP address, they can give you a static IP address that you can enter in this field.

WAN Network Mask

Enter **10** then type the subnet mask is dynamically served by the service provider for this session. The default subnet mask for the session is 0.0.0.0.

If the service provider does not dynamically provide a subnet mask, they can give you a subnet mask value that you can enter in this field.

RIP Accept Mode

Type **11** then select one of the following:

- **1—No RIP**
- **2—RIP Version 1**
- **3—RIP Version 2**
- **4—RIP Version 1 & 2 (default)**

RIP Send Mode

Type **12** then select one of the following:

- **1—No RIP**
- **2—RIP Version 1**
- **3—RIP Version 2 (default)**
- **4—RIP Version 1 & 2**

PPP Authentication

Enter **13** then select the authentication protocol provided by your service provider for PPP sessions. The authentication protocol type must match at the modem and the service provider. The options are:

- **1—NO Authentication** is required for the session.
- **2—PAP** where the modem sends authentication requests to the service provider and authentication occurs only once during the life of the link.
- **3—CHAP** where the service provider returns an authentication challenge to the modem during the authentication.

User Name

Enter **14** then type the login name for this PPP session to the **Login** name supplied by the service provider. Minimum login name length is one character and the maximum is 32 characters.

User Password

Enter **15** then type the login password for this PPP session to the **Login** password supplied by the service provider. Minimum password length is six characters and the maximum is 32 characters.

- 2 Enter **16** to **Apply new setting** to add the new RFC1483 bridged session to your session list. Or, you can Enter **17** to **Delete session**.

Permanently Save Sessions

After you have set up all the WAN sessions, select **Save Current configuration** from the **System Management** main menu as described in “[Saving the Current Configuration](#)” on page 131 or the changes will be lost if you reboot or power cycle the modem.

Edit an Existing Session

- 1 On the **WAN Session Management** menu, enter **1** to **View/Edit existing session**. The **WAN Session View/Edit** screen is displayed.

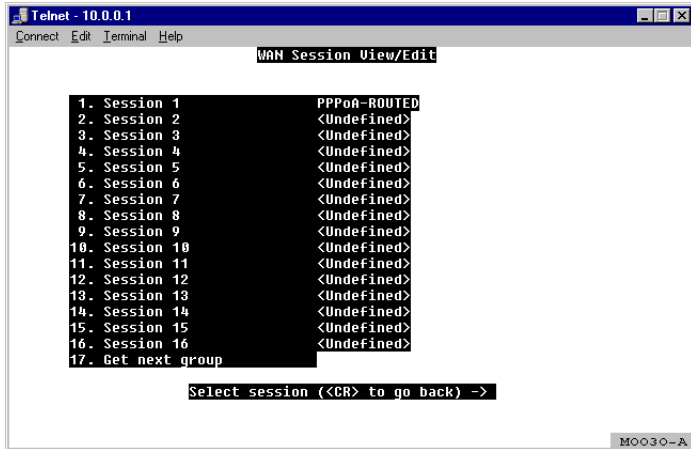

The screenshot shows a Telnet window titled "Telnet - 10.0.0.1" with a menu bar containing "Connect", "Edit", "Terminal", and "Help". The main window title is "WAN Session View/Edit". A list of sessions is displayed, with session 1 selected and highlighted in black. The list includes session numbers 1 through 16, each followed by its name, and a "Get next group" option. The names for sessions 2 through 16 are "<Undefined>". The name for session 1 is "PPPoA-ROUTED". Below the list, a prompt "Select session (<CR> to go back) ->" is visible. The bottom right corner of the window shows "M0030-A".

```

Telnet - 10.0.0.1
Connect Edit Terminal Help
WAN Session View/Edit

1. Session 1      PPPoA-ROUTED
2. Session 2      <Undefined>
3. Session 3      <Undefined>
4. Session 4      <Undefined>
5. Session 5      <Undefined>
6. Session 6      <Undefined>
7. Session 7      <Undefined>
8. Session 8      <Undefined>
9. Session 9      <Undefined>
10. Session 10    <Undefined>
11. Session 11    <Undefined>
12. Session 12    <Undefined>
13. Session 13    <Undefined>
14. Session 14    <Undefined>
15. Session 15    <Undefined>
16. Session 16    <Undefined>
17. Get next group

Select session (<CR> to go back) ->
M0030-A

```

- 2 Enter the session number to display the session screen. (The example below shows session 1, PPPoA-ROUTED.)

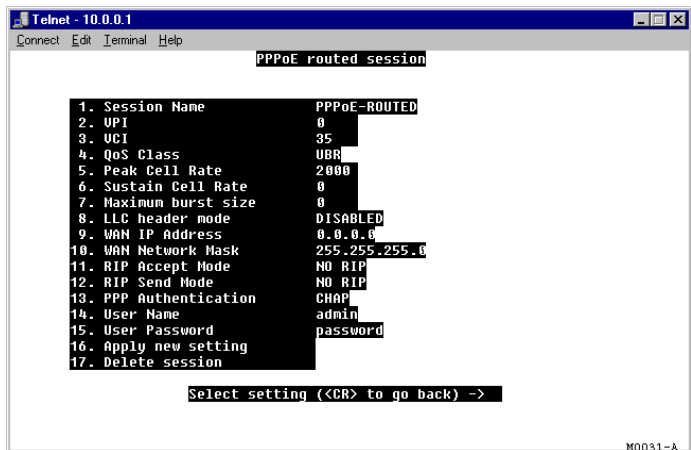

The screenshot shows a Telnet window titled "Telnet - 10.0.0.1" with a menu bar containing "Connect", "Edit", "Terminal", and "Help". The main window title is "PPPoE routed session". A list of configuration options is displayed, with option 1 selected and highlighted in black. The options include session name, UPI, UCI, QoS Class, Peak Cell Rate, Sustain Cell Rate, Maximum burst size, LLC header mode, WAN IP Address, WAN Network Mask, RIP Accept Mode, RIP Send Mode, PPP Authentication, User Name, User Password, and a "Delete session" option. The values for each option are shown to the right of the option name. Below the list, a prompt "Select setting (<CR> to go back) ->" is visible. The bottom right corner of the window shows "M0031-A".

```

Telnet - 10.0.0.1
Connect Edit Terminal Help
PPPoE routed session

1. Session Name   PPPoE-ROUTED
2. UPI            0
3. UCI            35
4. QoS Class      UBR
5. Peak Cell Rate 2000
6. Sustain Cell Rate
7. Maximum burst size
8. LLC header mode
9. WAN IP Address 0.0.0.0
10. WAN Network Mask
11. RIP Accept Mode
12. RIP Send Mode
13. PPP Authentication
14. User Name      admin
15. User Password password
16. Apply new setting
17. Delete session

Select setting (<CR> to go back) ->
M0031-A

```

- 3 Change settings as appropriate. See these sections for detailed information about editing parameters for these protocols:
 - **RFC 1483 bridged session**, see [page 108](#)
 - **RFC 1483 routed session**, see [page 110](#)
 - **PPPoA routed session** or **PPPoE routed session**, see [page 113](#)
- 4 Select **Apply new setting** to immediately activate the changes that you have made for this session.
- 5 Select **Save Current configuration** from the Main Menu as described in “[Saving the Current Configuration](#)” on [page 131](#) or the changes will be lost upon reboot or power cycle.

MANAGE DSL

Use the **DSL** menu to set up and manage the G.shdsl transmission line. This menu allows you to:

- view the DSL configuration
- configure the DSL line
- monitor the DSL statistics
- test the DSL line

From the **System Management** main menu ([page 102](#)), enter **3** to display the **DSL Management** menu.

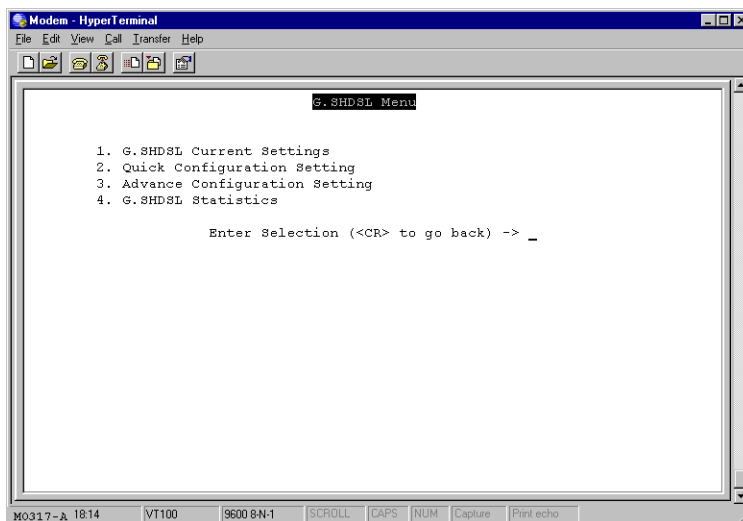

Configure G.shdsl Parameters

You can complete either a quick configuration or an advanced configuration for the G.shdsl line parameters. The following sections provide procedures for each configuration type.

Complete a Quick Configuration

- 1 From the **G.SHDSL Menu**, enter **2** to display the **G.SHDSL Quick Configuration** menu.

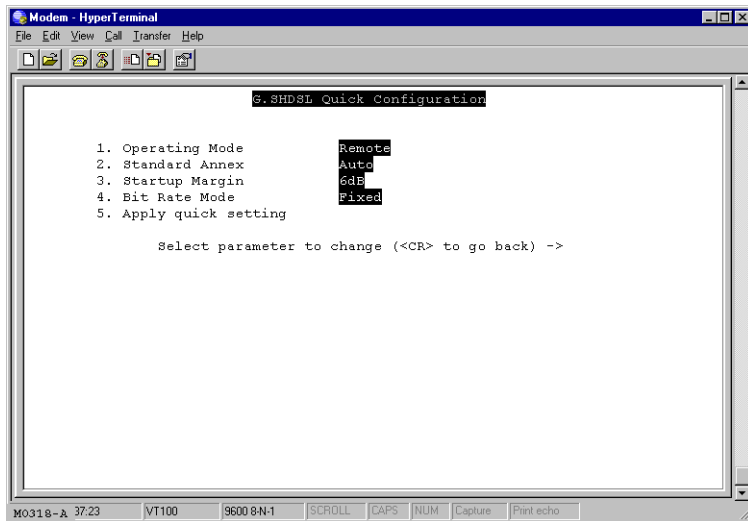

- 2 Configure the following parameters as directed by your service provider:

Operating Mode

Type **1** then select **1** for **Remote** and **2** for **Central-Office**.

When the modem is connected to a service provider through a DSLAM, the operating mode is **Remote** (default setting). When two modems are used in a point-to-point application (LAN extension, for example), one modem at the customer or user site is set to **Remote**, and the second modem in the CO or wiring closet is set to **Central-Office**. For instruction on setting up G.shdsl parameters and other related parameters for a point-to-point modem application, go to Chapter 7, "Implementing a Point-to-Point LAN Extension."

Standard Annex

Type **2** then select one of the following Annexes:

- **1—Annex-A** for operating conditions typically found in the North American implementation of G.shdsl
- **2—Annex-B** for operating conditions typically found in the European implementation of G.shdsl. This is the default mode for the MM701G modem.
- **3—Auto** for automatically negotiating the Annex A or B standard by which this modem, and the device to which this modem is attached, can operate. This is the default mode for the MM702G modem.
- **4—Annex-B_ANFP** for operating conditions that include the Annex B standard with Access Network Frequency Plan Pulse Spectral Density (PSD) mask.
- **5—Auto_ANFP** for automatically negotiating the Annex A or B standard with Access Network Frequency Plan Pulse Spectral Density (PSD) mask.

Startup Margin

Type **3** then select a number from **1** to **21** for possible values between **-10dB** through **10dB**, or select **22** to completely **Disable** the margin. The target signal-to-noise margin, in decibels, that the modem must achieve with a BER of 10^{-7} or better to successfully complete synchronization. The default margin value is 6 dB. A lower margin may result in a higher data rate, but it can increase noise on the line.

Bit Rate Mode

Type **4** then select either **1** for **Adaptive** or **2** for **Fixed** mode. Bit rate mode indicates how the modem synchronizes with the device to which it is attached. The default for the MM702G modem is **Fixed** mode. The default for the MM701G modem is **Adaptive** mode. The following provides more description for each mode.

- **Fixed** mode indicates that the modem will synchronize with the other end (a DSLAM or another modem) at a fixed bit rate through negotiation. The modem will synchronize at the best rate, up to the data rate specified (page 122), that can be achieved by both ends.
- **Adaptive** mode indicates that prior to modem negotiating a rate, the modem performs an adaptation phase during which it determines a best possible rate based on conditions of the line. After adaptive mode, the modem will then negotiate the best rate that can be achieved with the other end, based on the adaptation results.

3 Type **5** to **Apply new configuration** for the G.shdsl settings.

Complete an Advanced Configuration

- From the **G.SHDSL Menu**, enter **3** to display the **G.SHDSL Advanced Configuration** menu.

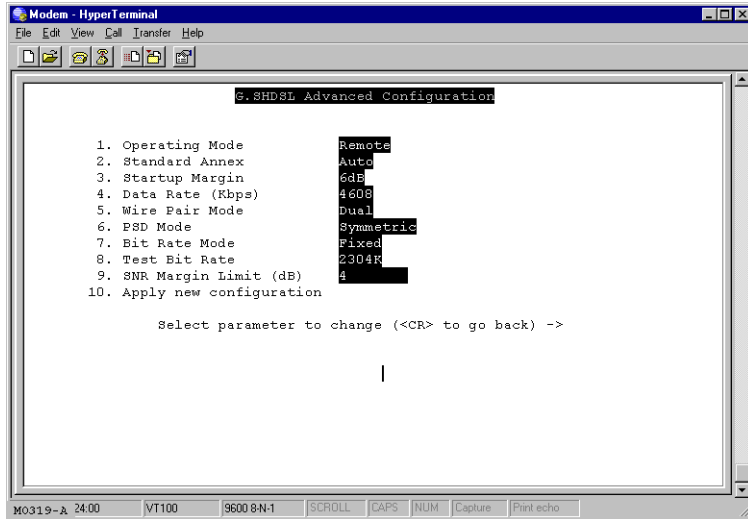

- Configure the following parameters as directed by your service provider:

Operating Mode

Type **1** then select **1** for **Remote** and **2** for **Central-Office**.

When the modem is connected to a service provider through a DSLAM, the operating mode is **Remote** (default setting). When two modems are used in a point-to-point application (LAN extension, for example), one modem at the customer or user site is set to **Remote** and the second modem in the CO or wiring closet is set to **Central-Office**. For instruction on setting up G.shdsl parameters and other related parameters for a point-to-point modem application, go to Chapter 7, “Implementing a Point-to-Point LAN Extension.”

Standard Annex

Type **2** then select one of the following Annexes:

- **1—Annex-A** for operating conditions typically found in the North American implementation of G.shdsl
- **2—Annex-B** for operating conditions typically found in the European implementation of G.shdsl. This is the default mode for the MM701G modem.
- **3—Auto** for automatically negotiating the Annex A or B standard by which this modem, and the device to which this modem is attached, can operate. This is the default mode for the MM702G modem.
- **4—Annex-B_ANFP** for operating conditions that include the Annex B standard with Access Network Frequency Plan Pulse Spectral Density (PSD) mask.
- **5—Auto_ANFP** for automatically negotiating the Annex A or B standard with Access Network Frequency Plan Pulse Spectral Density (PSD) mask.

Startup Margin

Type **3** then select a number from **1** to **21** for possible values between **-10dB** through **10dB**, or select **22** to completely **Disable** the margin. The target signal-to-noise margin, in decibels, that the modem must achieve with a BER of 10^{-7} or better to successfully complete synchronization. The default margin value is 6 dB. A lower margin may result in a higher data rate, but it can increase noise on the line.

Data Rate (kbps)

Type **4** then select a data rate (number **1** through **34**) which determines the maximum transmission rate, in kilobits per second, up to which the modem can negotiate and synchronize with another device (modem or a DSLAM) to which it is attached. When the **Bit Rate Mode** (page 123) is set to **Fixed**, the range of values are (ADC modems comply with the standard G.shdsl data rate range):

- for the MM702G modem, 384 kbps to 4608 kbps, in 128 kbps increments (default value is 4608)
- for the MM701G modem, 192 kbps to 2304 kbps, in 64 kbps increments

Rates down to 64 kbps are supported only when operating in single-pair, point-to-point mode with another ADC modem. (see [Chapter 7, “Implementing a Point-to-Point LAN Extension”](#)).

When the **Bit Rate Mode** (page 123) is set to **Adaptive** for an MM701G (**Adaptive** is MM701G default value) or for an MM702G set to **Single Wire Pair Mode** only (see below), this field is automatically set to **Adaptive**. An MM702G in **Dual Wire Pair Mode** cannot be used in **Adaptive Bit Rate Mode**.

Wire Pair Mode

Type **5** then select a wire mode. For the MM701G modem, **Single** mode is the only setting available. For the MM702G modem, you can select either **1** for **Single** or **2** for **Dual** mode; **Dual** mode is the default. Wire mode indicates whether the G.shdsl modem is operating in a two-wire mode (**Single**) or a four-wire mode (**Dual**).

PSD Mode

Type **6** then select which Power Spectral Density (PSD) which plots the variations of signal power with signal frequency for the G.shdsl transmission between the modem and the DSLAM or the modem and another modem. Select **1** for **Symmetric** PSD which indicates that the PSD mask for both sides of the transmission (the CO- and remote-side) are the same (symmetric).

Asymmetric PSD indicates that the PSD mask for both sides of the transmission (the CO- and remote-side) are not the same (asymmetric). There are two unique numeric values (**AsymmetricRate1** and **AsymmetricRate2**) used to determine the asymmetric PSD mask based on the Annex A or Annex B standard that you selected. Select **2** for **AsymmetricRate1** which is 784 kbps for Annex A and 2312 kbps for Annex B. Select **3** for **AsymmetricRate2** which is 1552 kbps for Annex A and 2056 kbps for Annex B.

Both ends of the connection must be set for the same Symmetric or Asymmetric PSD. The default is **Symmetric**.

Bit Rate Mode

Type **7** then select either **1** for **Adaptive** or **2** for **Fixed** mode. Bit rate mode indicates how the modem synchronizes with the device to which it is attached. The default for the MM702G modem is **Fixed** mode. The default for the MM701G modem is **Adaptive** mode. The following provides more description for each mode.

- **Fixed** mode indicates that the modem will synchronize with the other end (a DSLAM or another modem) at a fixed bit rate through negotiation. The modem will synchronize at the best rate, up to the data rate specified (page 122), that can be achieved by both ends.
- **Adaptive** mode indicates that prior to modem negotiating a rate, the modem performs an adaptation phase during which it determines a best possible rate based on conditions of the line. After adaptive mode, the modem will then negotiate the best rate that can be achieved with the other end, based on the adaptation results. An MM702G in **Dual Wire Pair Mode** cannot be used in **Adaptive Bit Rate Mode**.

Test Bit Rate

Type **8** then select a rate (number **1** through **36**) for the test bit rate. This test bit rate is used by the manufacturer for internal use only.

SNR Margin Limit

Type **9** then enter a value from -64 to 63. This value indicates the minimum SNR margin (in decibels) that must exist when the G.shdsl connection is synchronized and in order for the DSL MAR LED to be lit ON Green. The default value is 4.

- 3 Type **10** to **Apply new configuration** for the G.shdsl settings.

View G.shdsl Configuration

You can view G.shdsl current settings from the **G.SHDSL Current Settings** dialog. See “Complete an Advanced Configuration” on page 121 for definitions of these parameters that you previously set.

From the **G.SHDSL Menu**, enter **1** to display the **G.SHDSL Current Setting** menu.

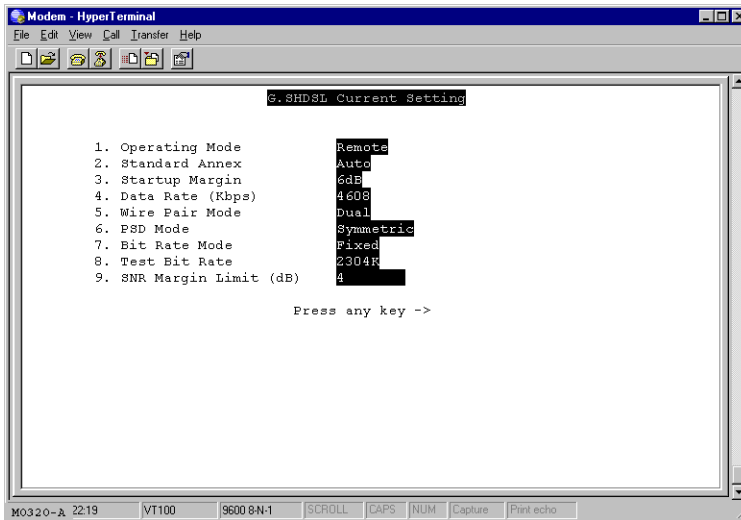

Monitor G.shdsl Statistics

From the **G.SHDSL Menu**, enter **4** to display the **Quick Configuration Setting** menu.

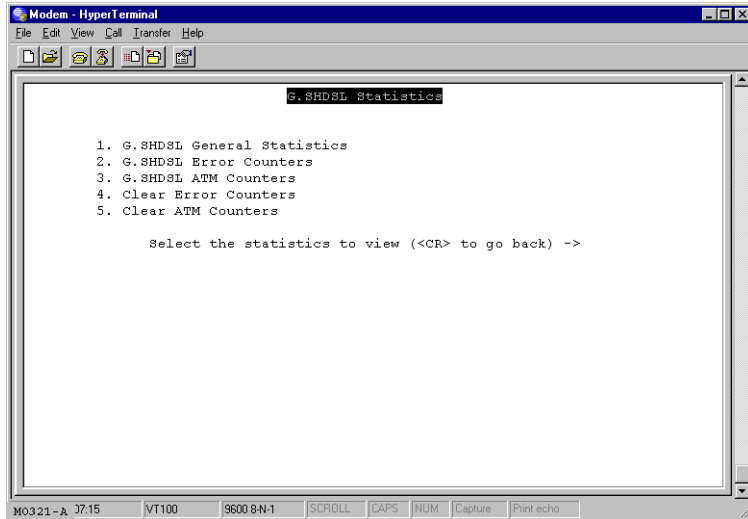

View G.shdsl General Statistics

1 From the **G.SHDSL Statistic Menu**, enter **1** to display the **G.SHDSL General Statistics** menu.

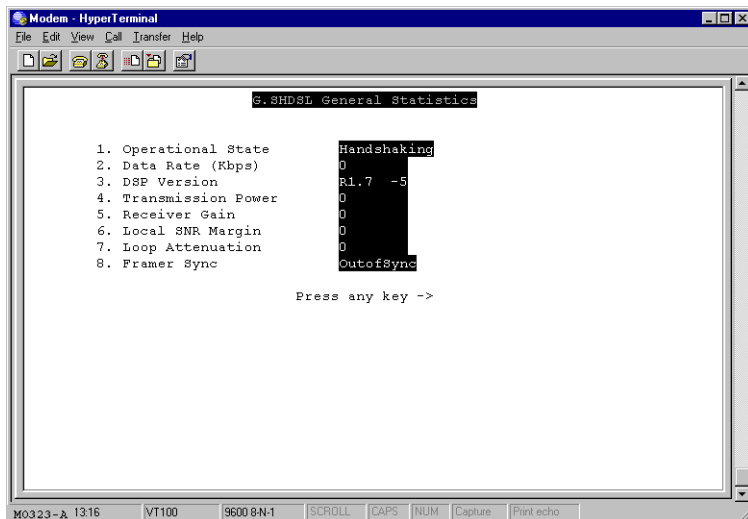

2 View the current statistics, as described below:

Operational State

Indicates the current mode of the modem. Operational states include:

- **handshaking**—indicates that the modem is negotiating with the DSLAM or the other modem
- **training**—indicates that the modem is learning the connection parameters
- **show time**—indicates the G.shdsl connection is operational

Data Rate

Indicates the bit rate for this transmission on the G.shdsl connection.

DSP Version

Identifies the version of G.shdsl firmware driver used for this modem.

Transmission Power

Indicates the local transmission power in decibels.

Receiver Gain

Indicates the amplifying factor for incoming signal in decibels.

Local SNR Margin

Indicates the current value for the SNR margin in decibels.

Loop Attenuation

Indicates the current and approximate loop attenuation (loop signal loss) in decibels.

Framer Sync

Indicates the current status of G.shdsl framer synchronization.

View G.shdsl General Statistics

- 1 From the **G.SHDSL Statistic Menu**, enter **2** to display the **G.SHDSL Error Counters** menu.

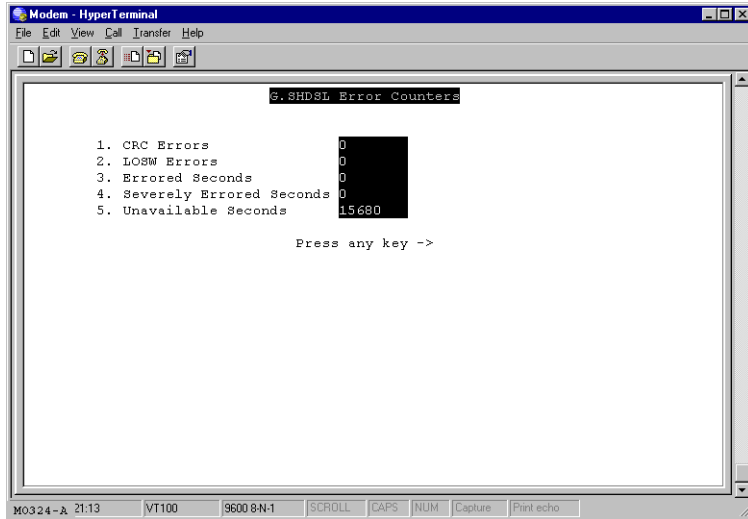

CRC Error

Indicates the total number of cyclic redundancy check (CRC) errors that have occurred on the G.shdsl connection since the last time that the G.shdsl error counters were cleared. CRC is an error checking technique used to ensure the integrity of data during transmission.

LOSW Errors

Indicates the total number of cyclic redundancy check (CRC) errors that have occurred on the G.shdsl connection since the last time that the G.shdsl error counters were cleared. CRC is an error checking technique used to ensure the integrity of data during transmission.

Errored Seconds

Indicates the total number of seconds in which one or more CRC errors occurred since the last time that the G.shdsl error counters were cleared.

Severely Errored Seconds

Indicates the total number of seconds in which 50 or more CRC errors occurred since the last time that the G.shdsl error counters were cleared.

Unavailable Seconds

Indicates the total number of seconds that the G.shdsl connection has been non-operational due to loss of synchronization or excessive errors since the last time that the G.shdsl error counters were cleared.

2 Click one of the following:

- **Clear**—resets all the counters to zero.
- **Refresh**—updates the page with current error counts.

View ATM Counters

1 From the **G.SHDSL Statistic Menu**, enter **3** to display the **ATM Statistics** menu.

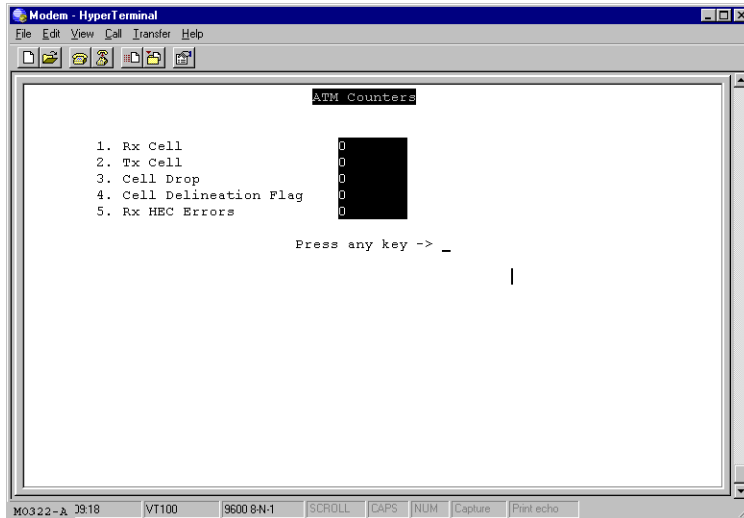

2 View the current statistics, as described below.

Rx Cell

Indicates the total number of cells received by the modem on the DSL interface.

Tx Cell

Indicates the total number of cells transmitted by the modem over the DSL interface.

Cell Drop

Indicates the total number of cells dropped by the modem.

Cell Delineation Flag

Indicates if cell delineation errors have occurred on the modem. A **0** indicates that no errors have occurred A **1** indicates that errors have occurred.

Rx HEC Errors

Indicates the total number of received ATM cells marked with uncorrectable header errors as indicated in the header-error control (HEC) byte.

- 3 Enter 5 on the **G.SHDSL Statistic Menu** to **Clear** the error counters.

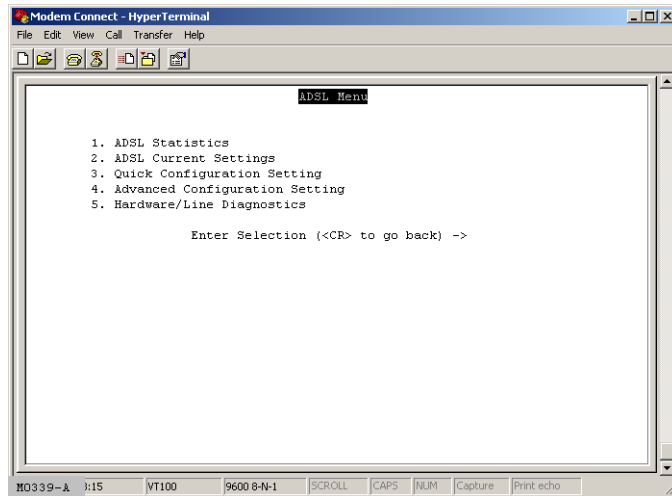

RESTORING FACTORY DEFAULTS

When you configure the modem, you change the factory default settings to new values. You can return these parameters to their default values to provide a known starting point if you are troubleshooting, or you simply want to configure new parameters.



Active links may be lost when you reset to factory default values.

- 1 From the **System Management** menu, enter **6** to **Restore Factory Configuration**.

```
Telnet - 10.0.0.1
Connect Edit Terminal Help
System Management
1. WAN Session Management
2. LAN Management
3. DSL Management
4. System Information
5. Save Current Configuration
6. Restore Factory Configuration
7. Software Update
8. Reboot
9. Logout
Overwrite with default configuration? CONFIRM (yes/no) : █
MO043-A
```

- 2 Do one of the following at the prompt:
 - Enter **Y** if you want to return all values to their original factory values.
 - Enter **N** if you do not want to return all values to their original factory values.

SAVING THE CURRENT CONFIGURATION

Use the **Save Current Configuration** page for saving your current configuration to flash memory. This prevents current changes from being lost in the event the modem is reset or power is cycled.

- 1 From the **Main Menu**, enter **5** to **Save Current Configuration**.

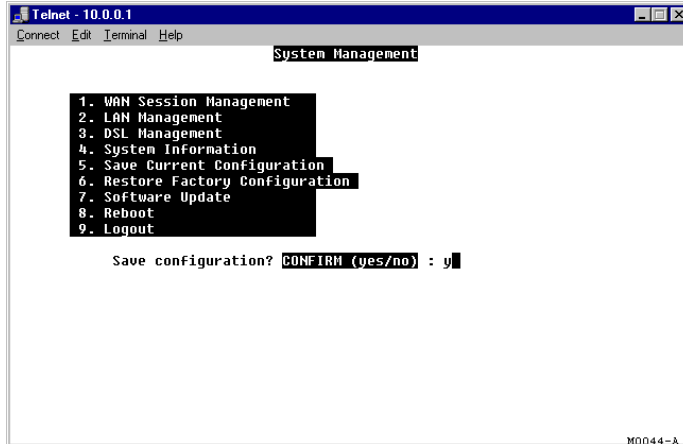

- 2 Do one of the following at the prompt:
 - Enter **Y** if you want to save the current configuration.
 - Enter **N** if you do not want to save the current configuration, but return to the previous configuration.

UPDATING SYSTEM SOFTWARE

If you need to update the modem software, use the Web interface HTTP upgrade (see “[Update System Software](#)” on page 96). Through the Web interface HTTP upgrade capability, you can transfer software (.bin) and http file upgrades to the modem.



It is recommended that you use the Web interface HTTP to download software. If you choose to use TFTP to download a software upgrade, contact the ADC technical assistance center for upgrade procedures (see [Appendix C](#) on page 147 for contact information).

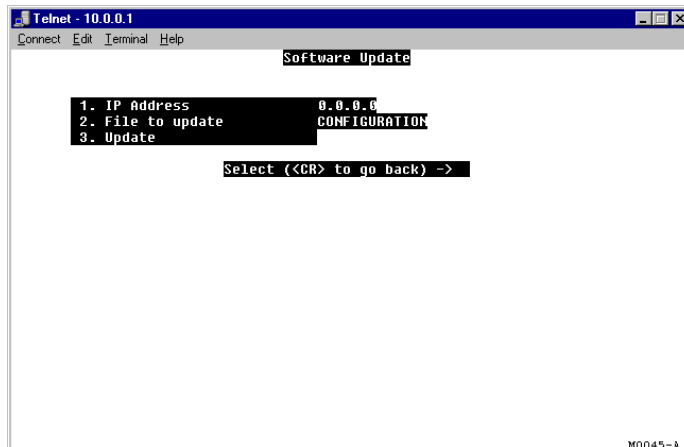

VIEWING SYSTEM INFORMATION

The System Information page is a read-only summary of the current modem configuration. It includes information about the firmware release, model, release date, MAC address, and DSP version. This information is often used by technical support when troubleshooting.

From the **Main Menu**, enter **4** for **System Information**.

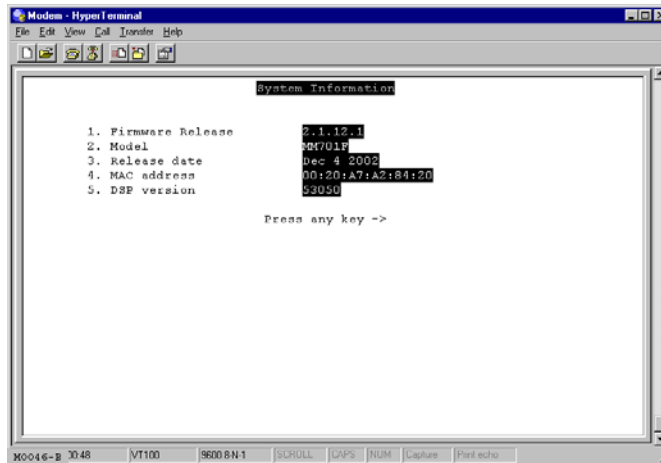

REBOOTING THE MODEM

Before you reboot the modem, save configuration changes as described in “Saving the Current Configuration” on page 131.

- 1 From the **Main Menu**, enter **8** to **Reboot**.

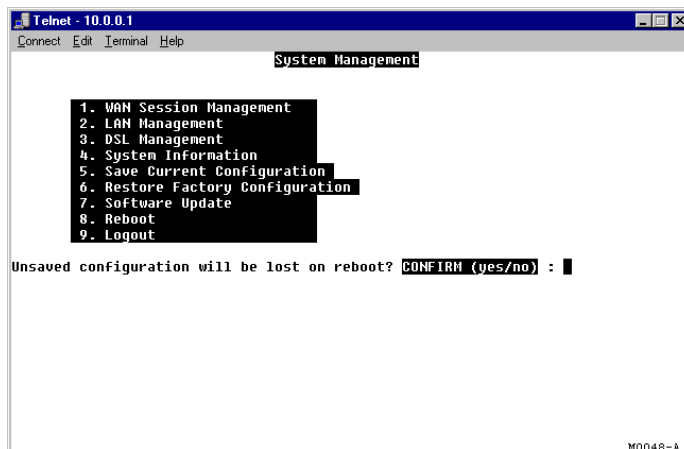

- 2 Do one of the following at the prompt:
 - Enter **Y** if you want to reboot the modem.
 - Enter **N** if you want to cancel the reboot.

SPECIFICATIONS

B

The MM701G and MM702 G are DSL modems that take advantage of G.shdsl technology by offering fixed and rate-adaptive communication at equal rates going both upstream and downstream. In addition, the modems also provide:

- sessions for precise control of security, performance and management of users and resources per session. Allowing Service providers to offer additional services and class of service for Internet access, private ATM networks or connections to application servers like video servers or voice gateways.
- self-installation for non-technical users

For further information, reference the following:

Section	Page
Overview	136
Data Specifications	137
Hardware Specifications	141
Rate vs. Reach	145

OVERVIEW

The MM provides:

- fixed-rate or rate-adaptive, symmetric G.shdsl transmission up to 2.3 Mbps
- multiple session types:
 - PPP over ATM (RFC 2364)
 - RFC 1483 bridging over ATM AAL5
 - RFC 1483 routing over ATM AAL5 (IPoA)
- 32 simultaneous sessions of the same or different types
- support for point-to-point LAN extension
- DHCP (client and server) for sending and receiving dynamic IP addresses, DHCP default gateway, and DNS server
- DNS Relay
- NAT for IP address translation
- Web interface HTTP upgrade for modem software updates
- RIP versions 1 and 2 for dynamic IP routing information exchange
- multiple management options:
 - serial interface
 - telnet
 - Web interface
 - SNMP agent
- 10Base-T LAN interface with MDI/MDI-X switch
- front panel LEDs for troubleshooting and monitoring LAN and DSL connections
- PAP and CHAP for PPP login name and password authentication
- ATM Quality of Service selection
- statistics for monitoring network traffic
- diagnostic tests to assist technical support personnel

DATA SPECIFICATIONS

VLAN Support

The MM701G and MM702G modems allow larger packet sizes to accommodate VLAN traffic.

DSL Standards

- Annex A (991.2)
- Annex B (991.2)

ATM standards

- ATM Forum UNI Version 3.1 and UNI Version 4.0
- ITU-T Q.2931, Q.2971 signaling
- ITU I.363.5 ATM Adaptation Layer 5
- ITU I.432 Cell Delineation and HEC
- ITU I.361 ATM Cell Format
- Classes of Service: CBR, UBR, VBR-nrt
- Virtual Circuits: 32 for data

Internetworking Features

- PPP: 1332, 1661, 1638, 1570
- NAT: 1631
- DHCP Server & Client: 2131, 2132
- Dynamic IP routing, ARP: 826, RIP: 1058, 1723
- TCP/IP: 1112, 1122, 950, 894, 793, 791, 1812
- BOOTP: 951, 1542
- TFTP: 1350
- IP over ATM: 1577
- RIP V2: 1723

WAN Protocols

- IETF RFC 2364 PPP over AAL5 (VC multiplexing and LLC encapsulation)
- IETF RFC 2684 Multiprotocol encapsulation over AAL5
- IETF RFC 1577 Classical IP over ATM

Security

- PPP authentication - PAP/CHAP: 1334, 1994
- Web, Craft console, and Telnet password with different user administration levels

Management

- Embedded SNMP agent, Terminal, Telnet with Web based configuration and management tool
- Auto provisioning extensions
- Concise MIB: 1212, MIB-II: 1213, Bridge MIB: 1493
- SNMP MIB: 1471, 1472, 1473, 1474
- SNMP: 1157
- Remote Configuration

Software Upgrade

- HTTP download into built-in flash memory
- Remote download (DSLAM support required)

Encapsulation

When you activate RFC 1483 system mode, you can select WAN encapsulation as VC multiplexing for some sessions and LLC encapsulation for other sessions.

PPP	
Authentication (PAP/CHAP)	Provides authentication of PPP sessions for security through Password and Challenge-Handshake Authentication Protocols (RFC 1994).
Network Address Translation	Network Address Translation (NAT) maps LAN side private IP address to the public IP address assigned to the 32 virtual channels (RFC 1631). You can map to two private addresses to each of the 32 sessions for a total of 64 addresses.
Routing	
Routing Protocol	Supports RFC 1724 Routing Information Protocol (RIP and RIP Version 2).
Encapsulation	Supports Logical Link Control (LLC) or VC-based multiplexing (RFC 1483).
Static Routes	Supports up to 32 static routes.
Address Resolution	Supports Address Resolution Protocol (ARP) over the LAN port (RFC 826).
Bridging	
Bridging and Address Learning	Implements a transparent learning bridge with a bridging table of 1024 entries.
Encapsulation	Supports Logical Link Control (LLC) or VC-based multiplexing (RFC 1483).
Spanning Tree	Provides Spanning Tree support per IEEE 802.1d.

RFCs

- RFC 1483 Multiprotocol Encapsulation over ATM (Bridging/Routing)
- RFC 2364 PPP Encapsulation over ATM
- RFC 1994 for PAP/CHAP Authentication
- RFC 1631 IP Network Address Translator (for NAT)
- RFC 1350 for TFTP client
- RFC 2131 and RFC 2132 for DHCP server and relay protocols (supported only in RFC 1483 Bridging mode) and extensions, respectively

MIBs

- Bridge MIB - 2684
- SNMP MIBs - 1471, 1472, 1473, 1474
- MIB 1213 - MIB II

Default Session Parameter Values

Session Parameter	Bridge	IPoA Router	PPPoA-Router	PPPoE-Router
Protocol	RFC1483 - Bridge	RFC1483 - Router	PPPoA	PPPoE
State	Enable	Enable	Enable	Enable
IP Address	N/A	0.0.0.0	N/A (Dynamic)	N/A (Dynamic)
Subnet Mask	N/A	255.0.0.0	N/A (Dynamic)	N/A (Dynamic)
NAT	Not applicable	Disabled	Disabled	Disabled
RIP Send	N/A	RIPv2(Bcast)	RIPv2(Bcast)	RIPv2(Bcast)
RIP Accept	N/A	RIP I & II	RIP I & II	RIP I & II
Virtual Path ID (VPI: 0 - 4095)	0	0	0	0
Virtual Channel ID (VCI: 32 - 65536)	0	0	0	0
ATM QoS	UBR	UBR	UBR	UBR
QoS Peak Cell Rate (PCR)	5500	5500	5500	5500
QoS Sustainable Cell Rate (SCR)	0	0	0	0
QoS Maximum Burst Size (MBS)	0	0	0	0
Encapsulation	LlcBridged	LlcRouted	LLC (Enabled)	LLC (Enabled)
Login Name	N/A	N/A	admin	admin
Login Password	N/A	N/A	password	password
Authentication	N/A	N/A	CHAP	CHAP

HARDWARE SPECIFICATIONS

LED

- Power
- Ethernet: Link, Tx, Rx, Collision
- DSL: Sync, Tx, Rx, Margin

Connectors

- DSL Interface: RJ-11
- 10Base-T: RJ-45
- Console Port: RJ-45 (serial connection to RS-232 for local configuration)

LAN Interface

- 10Base-T (IEEE 802.3i)
- Connector: RJ-45 with MDI/MDI-X switch

WAN Interface

G.shdsl (Symmetrical High-Speed Digital Subscriber Line)

Maximum transmission rate:	
Downstream	2304 kbps for single-pair; 4608 kbps for two-pair
Upstream	2304 kbps for single-pair; 4608 kbps for two-pair
Minimum transmission rate to sync	192 kbps for MM701G 384 kbps for MM702G
Connector	RJ-11

ATM (Asynchronous Transfer Mode)

ATM Adaptation Layer	AAL5 (ITU I.363.5)—Supports encapsulation and de-encapsulation of AAL5 Protocol Data Units (PDUs) for convergence. Segmentation and Reassembly (SAR) layer segments and reassembles AAL5 PDUs into ATM cells that are 48 byte SAR-PDUs.
ATM Layer	Attaches or strips the 5-byte header to the 48-byte SAR-PDU.
Cell Format	Format complies with ITU I.361 ATM cell format. Cell delineation complies with ITU I.432 Cell Delineation and HEC. Cells are fixed length (53 bytes), including 5 bytes of header and 48 bytes of payload. Included in the header are the VPI and VCI number.
Virtual Circuit type	Permanent Virtual Circuit (PVC) per ATM forum UNI Version 3.1.
Maximum Virtual Circuits	32 virtual circuits that can simultaneously connect to service providers for sessions encapsulated either as PPP or RFC 1483 Bridging/Routing.

Connector Pinouts

The following sections provide the pinout information for the various modem connectors.

DSL Port (RJ-11)

The following table shows the signal on each pin of the DSL port for a 2-wire G.shdsl application. The connector for this interface is an RJ-11. The modem accommodates Tip and Ring reversal on this one loop. See [“Connect Cables” on page 3](#) for the location of this port.

Pin	Signal
1	Not used
2	No connection
3	Tip (Loop A)
4	Ring (Loop A)
5	No connection
6	Not used

The following table shows the signal on each pin of the DSL port for a 4-wire G.shdsl application. The connector for this interface is an RJ-11. The modem accommodates Tip and Ring reversal on each separate Loop A and Loop B. See [“Connect Cables” on page 3](#) for the location of this port.

Pin	Signal
1	Not used
2	Tip (Loop B)
3	Tip (Loop A)
4	Ring (Loop A)
5	Ring (Loop B)
6	Not used

10Base-T Port (RJ-45)

The following table shows the signal on each pin of the 10Base-T port connector when the switch is in either the MDI or the MDI-X position. The connector for this interface is an RJ-45. See “Connect Cables” on page 3 for the location of this port.

MDI	MDI-X	Signal	Description
1	3	TX+	Transmit Data (+)
2	6	TX-	Transmit Data (-)
3	1	RD+	Receive Data (+)
4	4	Not used	Not used
5	5	Not used	Not used
6	2	RD-	Receive Data (-)
7	7	Not used	Not used
8	8	Not used	Not used

Console Port (RJ-45)

The following table gives the signal designations and pin numbers for each end of the RJ-45 to RS-232 cable that is used between the modem Console port (RJ-45) and the PC Serial port (DB-9).

PC RS-232 Serial Port (DB-9)	Modem Console (RJ-45)	Signal	Description
	1	RTS	Ground
	2	DTR	Ground
3	3	TxD	Transmit Data
	4	GND	Ground
5	5	GND	Ground
2	6	RxD	Receive Data
	7	DSR	Ground
	8	CTS	Ground

RATE VS. REACH

The following rate versus reach charts show values per each G.shdsl loop (Loop A or Loop B).

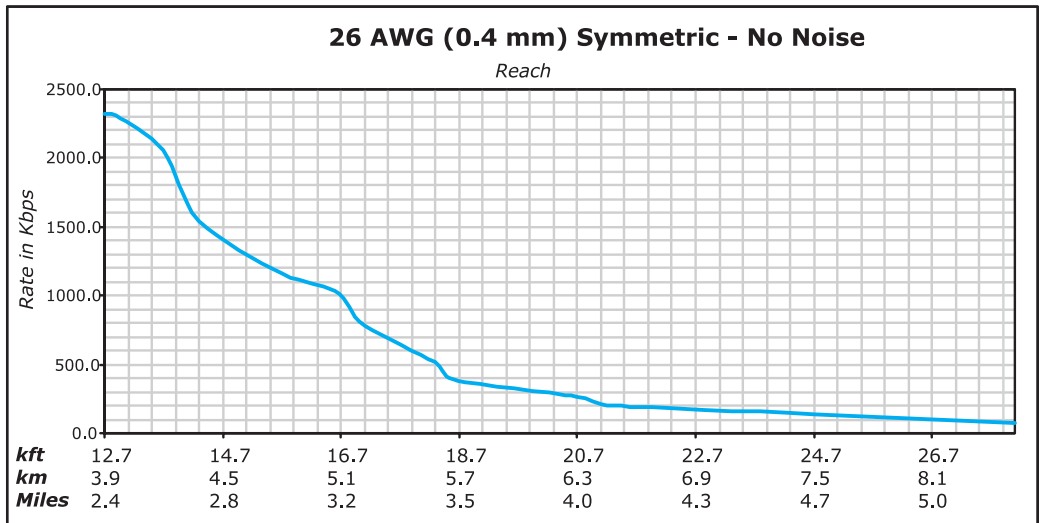
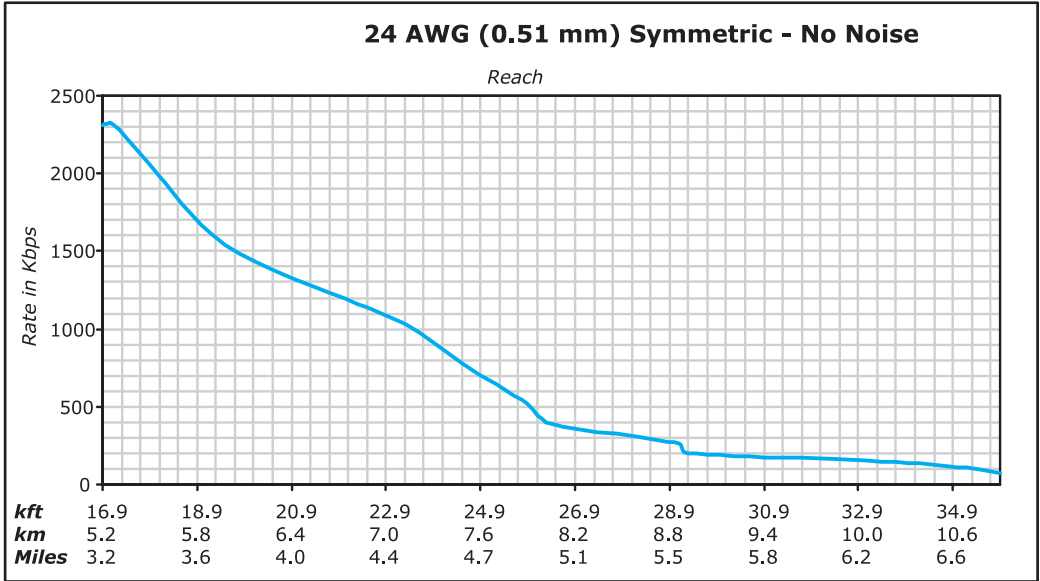

CONTACTING ADC



ADC Customer Service Group provides expert pre-sales and post-sales support and training for all its products. Technical support is available 24 hours a day, 7 days a week by contacting the ADC Technical Assistance Center (TAC).

Sales Assistance

800.366.3891 extension 73000
(USA and Canada)
952.917.3000
Fax: 952.917.3237

- Quotation Proposals
- Ordering and Delivery
- General Product Information

Systems Integration

800.366.3891, extension 73000
(USA and Canada)
952.917.3000

- Complete Solutions (from concept to installation)
- Network Design and Integration Testing
- System Turn-Up and Testing
- Network Monitoring (upstream or downstream)
- Power Monitoring and Remote Surveillance
- Service/Maintenance Agreements
- Systems Operation

ADC Technical Assistance Center

800.366.3891, extension 73223 or
952.917.3223
Fax: 952.917.3244
Email: wsd.support@adc.com

- Technical Information
- System/Network Configuration
- Product Specification and Application
- Training (product-specific)
- Installation and Operation Assistance
- Troubleshooting and Repair/Field Assistance

Online Technical Support

- www.adc.com/technicalsupport

Online Technical Publications

- www.adc.com/documentationlibrary/technicalpublications

Product Return Department

800.366.3891 extension 73748 or

952.917.3748

Fax: 952.917.3237

Email: repair&return@adc.com

- ADC Return Material Authorization (RMA) number and instructions must be obtained before returning products.

All telephone numbers with an 800 prefix are toll-free in the USA and Canada.

GLOSSARY

D

10Base-T	The Institute of Electrical and Electronic Engineers (IEEE) 802.3 specification for Ethernet over thin coaxial cable.
AAL2	ATM Adaptation Layer 2. Used for compressed voice and video that is intolerant of delay. This layer is used by xDSL technology.
AAL5	ATM Adaptation Layer 5. AAL5 has been adopted by the ATM Forum from a Class of Service called High Speed Data transfer. It typically supports all types of data traffic. Originally designed to support TCP/IP.
ATM	Asynchronous Transfer Mode is a high bandwidth, low delay, connection-oriented, packet-like switching and multiplexing technique that uses 53-byte fixed-size cells to transmit voice, video and data over a network. ATM layers define how cells are formatted and provides the transport of the fixed length cells between the modem and the service provider (or endpoints of the virtual connection).
attenuation	The dissipation of the power of a transmitted signal as it travels over copper wire, measured in decibels (dB).
authentication	Security feature offered through PAP and CHAP with PPP sessions.
BER	Bit Error Rate is a measure of transmission quality. The ratio of error bits to the total number of bits transmitted.
bps	bit-per-second is the number of bits transferred during each second of data transmission.
CBR	Constant Bit Rate is a Service Class for the modem. It provides constant bit rate data with a timing relationship between the source and the destination. Also, a traffic class that carries a guaranteed constant bandwidth. Best suited for applications that require fixed bandwidth, such as uncompressed voice, video and circuit emulation. CBR is a Quality of Service class defined by the ATM Forum for ATM networks.
cell	A fixed-length packet. Also, the unit of data transmission used in ATM. Each ATM cell contains a fixed-size frame (53 bytes) consisting of a five-byte header and a 48-byte payload.

community string	A text string required for an SNMP trap to be received by a trap receiver(s). Also, a text string that identifies an SNMP community and is associated with specific access rights (read-only or read/write).
CRC	Cyclic Redundancy Check is a method used to verify the accuracy of data transmission.
DHCP	Dynamic Host Configuration Protocol. A TCP/IP protocol that enables PCs to obtain IP addresses from a DHCP server that dynamically assigns IP addresses.
DNS	Domain Naming System. A system for translating names of host computers into IP addresses.
downstream traffic	Communications from a service provider to a user.
encapsulation	The inclusion of data in a protocol header prior to transmission, which enables successful data transmission between different protocol networks.
ES	Errored Seconds is the seconds during which errors occur that prevent the payload from being corrected.
Ethernet	A protocol used for LAN traffic, which has a transfer rate of 10 or 100 Mbps.
flash memory	Non-volatile memory that can be erased and reprogrammed.
G.shdsl	Symmetrical High-Speed Digital Subscriber Line
gateway	A device (generally a router) that provides translation services to allow communication between two dissimilar networks.
IP	Internet Protocol is a TCP/IP protocol that controls packet transmission.
IP address	A 32-bit address used in IP routing. The address consists of four octets separated by decimals. The octets comprise a network section, a subnet section (optional) and a host section.
LAN	Local Area Network is a physically connected group of devices between which data transmission occurs at high speeds over relatively short distances.
LLC	Logical Link Control is an encapsulation protocol for data that you transmit from the modem over the WAN in 1483 Bridging/Routing mode.
LOF	Loss Of Frame is an error indicating that the receiving equipment has lost a frame.
LOS	Loss Of Signal is an error indicating that the receiving equipment has lost the signal.

MAC	Media Access Control is a physical address associated with a device such as a NIC. For modem configuration, the MAC is used to map inbound traffic (from a remote IP address) to an internal (LAN) IP address. Used with 1483 Bridging/Routing Mode.
margin	The noise margin in decibels that the modem must achieve with a BER of 10^{-7} or better to successfully complete initialization.
MIB	Management Information Base is a set of variables that define the configuration and status parameters for network management. Network management stations can retrieve information from and write information to an MIB. The Internet Engineering Task Force (IETF) specifies standard MIBS for certain types of devices, ensuring any NMS can manage the devices. Vendors can specify proprietary MIBs for their devices to fit specific needs.
NAT	Network Address Translation provides the means to map private IP addresses (LAN IP addresses) to public IP addresses (WAN session IP addresses).
NVRAM	Non-Volatile Random Access Memory is a medium for storing system configuration information, so the information is not lost when the system is reset.
octet	A TCP/IP term indicating eight bits.
PAP/CHAP	<p>Password Authentication Protocol and Challenge Handshake Authentication Protocol are two ways to authenticate PPP sessions. With PAP, the modem sends authentication requests to the service provider and authentication occurs only once during the life of the link.</p> <p>In CHAP, the service provider returns an authentication challenge to the modem during authentication. CHAP can be renegotiated during the life of the link. Also, both the modem and the service provider must support clear text versions of the password. The CHAP host field must be the same on both ends of the session.</p>
PDU	Protocol Data Unit is data as it appears at the interface between a particular sublayer and the sublayer immediately below.
POTS	Plain Old Telephone Service.
PPP	Point-to-Point Protocol exists between the hardware layer and the network-layer interface protocols. It is a widely used protocol for establishing connections on the Internet. PPP provides the set up and release of connections for each session. PAP/CHAP provide the authentication for the PPP sessions.
proxy IP address	The proxy IP address is the WAN IP address for one of the 32 sessions. The proxy IP address is used to enter static NAT entries. See IP address.
PVC	Permanent Virtual Circuit is a logical connection comprised of a predefined static route across a packet-switched network that is always in place and always available.

QoS	Quality of Service is the configured traffic parameters that are assigned to a virtual circuit, which specifies how quickly and how accurately data is transferred from the sender to the receiver.
RFC	Request For Comment is a series of notes that contain surveys, measurements, ideas, techniques, and observations, as well as proposed and accepted TCP/IP protocol standards. RFCs are available on the Internet.
RIP	Routing Information Protocol allows routers to update the routing tables automatically (for example with information such as how many hops between destinations). The version of RIP you select for the session must match the version supported by the service provider. Versions RIP1 and RIP-1 compatible are used for broadcast. Version RIP 2 is used for multicast.
SEF	Severely Errored Frames is the incoming signal has at least four consecutive errored framing patterns.
SES	Severely Errored Seconds is the seconds during which more than 2,500 bipolar errors are detected on the line.
session	The time during which two computers maintain a communication connection. An example is a connection configured between the Megabit Modem and the service provider.
SNMP	Simple Network Management Protocol is a protocol that specifies how to send information between a NMS and managed devices on a network. The managed devices run a program called an agent. The agent interprets SNMP request and responds to them. SNMP is used to set device configurations, read device configurations or read the device status.
Spanning Tree	A bridging protocol that detects and prevents loops from occurring in a system containing multiple bridges.
subnet mask	A type of IP address that allows a site to use a single IP address for multiple physical networks.
TCP	Transmission Control Protocol is a transport protocol used to map inbound traffic (from a remote IP address) to an internal (LAN) IP address. Establishes connection with remote user before data transmission.
TCP/IP	Transmission Control Protocol/Internet Protocol is a protocol used for communications between computers over networks and the internet.
TFTP	Trivial File Transfer Protocol is a protocol used to download card images or other files from an external TFTP server to the NVRAM of any installed cards, or to upload files from an installed card to an external TFTP server.
trap receivers	PCs configured to receive SNMP traps (messages).

traps	Autonomous, interrupt-driven, SNMP messages sent from a managed node to a network management station to indicate that an event has occurred.
UAS	UnAvailable Seconds is the number of seconds during which the line is unavailable.
UBR	Unspecified Bit Rate is an ATM traffic type used for LAN traffic. When network congestion occurs, the data is stored in a buffer until it can be sent.
UDP	User Datagram Protocol is a transport protocol used to map inbound traffic (from a remote IP address) to an internal (LAN) IP address. Uses a protocol port number for the destination at the remote location.
upstream traffic	Communications from a user to a service provider.
VCI	Virtual Channel Identifier is a 16-bit field addressing identifier in the header of an ATM cell used to route cell traffic. It identifies a particular VC link for a given VP.
VCMUX	Virtual Channel Multiplexer-based encapsulation used for networks with large numbers of virtual channels making it practical to carry a single protocol per virtual channel.
VC	A Virtual Channel is a logical connection in the ATM network over which ATM cells are transmitted.
VPI	Virtual Path Identifier is an 8-bit field addressing identifier in the header of an ATM cell that is used to route cell traffic. It identifies a particular VP link.
VP	A Virtual Path is a group of VCs carried between two points. The VP provides a means of bundling traffic traveling in the same direction. VPs are defined by a unique VPI value.
WAN	Wide Area Network is a network consisting of nodes located across a large geographical area. Also, the connection between a service provider and MM Modem.

INDEX

Numerics

10/100Base-T connector pinouts 144

10Base-T, description 149

A

adaptation layer 142

ATM

adaptation layer 142

cell format 142

description 149

max VCs 142

specifications 142

B

back-to-back

implementing 63

verifying connectivity 76

bridging specifications 139

C

cell formats 142

CO modem, configuring 70

configuration, saving 131

configuring

CO modem 70

CPE modem 66

connecting console port 100

connectivity, verifying back-to-back 76

connector pinouts 143

console port

description 144

connecting to 100

CPE modem, configuring 66

D

Data Specifications 137

Default Session Parameter Values 140

defaults

factory 130

settings 96

DHCP 118

downstream 150

DSL

connector pinouts 143

managing 118

quick configuration 58

E

Encapsulation 139

error counters 84

F

factory defaults

restoring 130

setting 96

full duplex 64

H

HTTP, software updating 96

I

IAD, rebooting 55

implementing, back-to-back 63

installing, modem 63

L

LAN

 extending 63

 setting up 118

 troubleshooting 64

M

MAC, description 151

managing

 DSL 118

 IAD 39

 system 57

modem

 installing 63

 rebooting 134

 storage 1

modem, rebooting 55

N

NAT

 description 151

 setting up 118

network interface card (NIC) 64

P

Physical Specifications 141

pinouts 143

point-to-point, LAN extension 63

PPP, specifications 139

R

rebooting modem 55

rebooting, IAD 55

rebooting, modem 134

restoring, factory defaults 130

RFCs 139

routing, specifications 139

S

saving current configuration 131

setting factory defaults 96

setting up

 LAN 118

 NAT 118

 telnet 103

 WAN 106

SHDSL, specifications 142

software, HTTP update 96

software, updating 53, 96

specifications 135

 ATM 142

 bridging 139

 PPP 139

 routing 139

 SHDSL 142

 WAN interface 142

status, viewing 82

storage 1

subnet mask description 152

system

 managing 57

 updating software 53, 96

 viewing information 133

T

technical specifications 135

telnet, setting up 103

TFTP

 description 152

 see HTTP 132

troubleshooting

 Ethernet NIC 64

 LAN connection 64

U

updating system software 53, 96

upstream description 153

V

verifying back-to-back connectivity 76

viewing

 error counters 84

 status 82

 system information 133

W

WAN

 interface specifications 142

 setting up 106

web interface

 managing IAD 39

ADC DSL Systems, Inc.

14402 Franklin Avenue
Tustin, CA 92780

Technical Assistance

Tel: 800.366.3891, ext. 73223

Tel: 952.917.3223

Fax: 952.917.3244

Email: wsd.support@adc.com

DOCUMENT: MM70xG-UM-01



1262834

Free Manuals Download Website

<http://myh66.com>

<http://usermanuals.us>

<http://www.somanuals.com>

<http://www.4manuals.cc>

<http://www.manual-lib.com>

<http://www.404manual.com>

<http://www.luxmanual.com>

<http://aubethermostatmanual.com>

Golf course search by state

<http://golfingnear.com>

Email search by domain

<http://emailbydomain.com>

Auto manuals search

<http://auto.somanuals.com>

TV manuals search

<http://tv.somanuals.com>