



## Aastra Model 6867i SIP IP Phone



### User Guide

### Release 3.3.1 SP3

41-001524-00 REV00 – 04.2014

# Software License Agreement

Aastra, hereinafter known as "Seller", grants to Customer a personal, worldwide, non-transferable, non-sublicenseable and non-exclusive, restricted use license to use Software in object form solely with the Equipment for which the Software was intended. This Product may integrate programs, licensed to Aastra by third party Suppliers, for distribution under the terms of this agreement. These programs are confidential and proprietary, and are protected as such by copyright law as unpublished works and by international treaties to the fullest extent under the applicable law of the jurisdiction of the Customer. In addition, these confidential and proprietary programs are works conforming to the requirements of Section 401 of title 17 of the United States Code. Customer shall not disclose to any third party such confidential and proprietary programs and information and shall not export licensed Software to any country except in accordance with United States Export laws and restrictions.

Customer agrees to not reverse engineer, decompile, disassemble or display Software furnished in object code form. Customer shall not modify, copy, reproduce, distribute, transcribe, translate or reduce to electronic medium or machine readable form or language, derive source code without the express written consent of the Seller and its Suppliers, or disseminate or otherwise disclose the Software to third parties. All Software furnished hereunder (whether or not part of firmware), including all copies thereof, are and shall remain the property of Seller and its Suppliers and are subject to the terms and conditions of this agreement. All rights reserved.

Customer's use of this software shall be deemed to reflect Customer's agreement to abide by the terms and conditions contained herein. Removal or modification of trademarks, copyright notices, logos, etc., or the use of Software on any Equipment other than that for which it is intended, or any other material breach of this Agreement, shall automatically terminate this license. If this Agreement is terminated for breach, Customer shall immediately discontinue use and destroy or return to Seller all licensed software and other confidential or proprietary information of Seller. In no event shall Seller or its suppliers or licensors be liable for any damages whatsoever (including without limitation, damages for loss of business profits, business interruption, loss of business information, other pecuniary loss, or consequential damages) arising out of the use of or inability to use the software, even if Seller has been advised of the possibility of such damages.

# Content

<b>Software License Agreement</b> .....	ii
<b>Welcome</b> .....	1
<i>About this Guide</i> .....	1
<i>Documentation</i> .....	1
<i>Phone Features</i> .....	1
<i>Requirements</i> .....	2
<i>Installation and Setup</i> .....	2
<b>IP Phone Keys</b> .....	3
<i>Key Panel</i> .....	3
<i>Key Description</i> .....	4
<i>Dialpad Keys</i> .....	6
<b>Getting Started</b> .....	7
<i>Plugging in and Starting the Phone</i> .....	7
<i>UI Overview</i> .....	10
<i>UI Navigation</i> .....	15
<b>Methods of Customizing Your Phone</b> .....	17
<i>Phone Options via the IP Phone UI</i> .....	17
<i>Phone Options via the Aastra Web UI</i> .....	20
<b>Phone Status</b> .....	23
<i>Phone Status via IP Phone UI</i> .....	23
<i>Finding Your Phone's IP Address</i> .....	25
<i>Phone Status via the Aastra Web UI</i> .....	26
<b>Customizing Your Phone</b> .....	28
<i>Language</i> .....	28
<i>Time and Date</i> .....	35
<i>Call Forward</i> .....	39
<i>Lock</i> .....	40
<i>Audio</i> .....	45
<i>Display</i> .....	51
<i>Dialpad</i> .....	52

<i>Restart</i> .....	53
<i>Emergency Dial Plan</i> .....	54
<b>Line and Call Appearances</b> .....	55
<b>Presence Key</b> .....	56
<i>Using the Presence Key</i> .....	56
<b>Configuring Softkeys</b> .....	57
<i>State-Based Softkeys</i> .....	59
<i>Softkey Display Behavior</i> .....	60
<i>Line Key</i> .....	61
<i>Speed Dial Key</i> .....	62
<i>Do Not Disturb (DND) Key</i> .....	67
<i>Busy Lamp Field (BLF) Key</i> .....	68
<i>BLF/List Key</i> .....	69
<i>Automatic Call Distribution (ACD) Key (for Sylantró Call Managers)</i> .....	71
<i>XML Key</i> .....	74
<i>Flash Key</i> .....	76
<i>Sprecode Key</i> .....	77
<i>Park/Pickup Keys</i> .....	78
<i>Call Forward Key</i> .....	81
<i>BLF/Xfer</i> .....	82
<i>Speed Dial/Xfer</i> .....	84
<i>Speed Dial/Conf</i> .....	86
<i>Directory Key</i> .....	88
<i>Callers List Key</i> .....	90
<i>Redial Key</i> .....	92
<i>Conference Key</i> .....	94
<i>Transfer Key</i> .....	95
<i>Intercom Key</i> .....	96
<i>Phone Lock Key</i> .....	97
<i>Paging Key</i> .....	98
<i>Empty Key</i> .....	100
<i>None Key</i> .....	101

<b>Making Calls</b> .....	102
<i>Dialing a Number</i> .....	102
<i>Pre-Dialing a Number</i> .....	102
<i>Using Handsfree Speakerphone</i> .....	103
<i>Using a Headset</i> .....	103
<i>Using Intercom Functionality</i> .....	104
<i>Redial</i> .....	105
<i>Mute</i> .....	108
<b>Receiving Calls</b> .....	109
<i>Answering an Incoming Call</i> .....	109
<i>Sending an Incoming Call to Voicemail</i> .....	109
<b>Handling Calls</b> .....	110
<i>Placing a Call on Hold</i> .....	110
<i>Transferring Calls</i> .....	111
<i>Conferencing Calls</i> .....	116
<i>Ending Calls</i> .....	121
<b>Managing Calls</b> .....	122
<i>Directory</i> .....	122
<i>Callers List</i> .....	130
<i>DND and Call Forward</i> .....	137
<b>Additional Features</b> .....	147
<i>Display DTMF Digits</i> .....	147
<i>Play Call Waiting Tone</i> .....	148
<i>Stuttered Dial Tone</i> .....	149
<i>XML Beep Support</i> .....	150
<i>Status Scroll Delay</i> .....	151
<i>Switch UI Focus to Ringing Line</i> .....	152
<i>Call Hold Reminder During Active Calls</i> .....	153
<i>Call Hold Reminder (on single hold)</i> .....	154
<i>Call Waiting Tone Period</i> .....	155
<i>Goodbye Key Cancels Incoming Calls</i> .....	156
<i>Message Waiting Indicator</i> .....	157
<i>Incoming Intercom Call Features</i> .....	158

<i>Group RTP Paging</i> .....	160
<i>Shared Call Appearance (SCA) Call Bridging</i> .....	161
<i>Star Codes</i> .....	162
<i>Other Features</i> .....	162
<b>Model M680i Expansion Module</b> .....	163
<i>Using the Expansion Modules</i> .....	164
<b>Troubleshooting Solutions</b> .....	165
<b>Limited Warranty</b> .....	Warranty-1
<i>Exclusions</i> .....	Warranty-1
<i>Warranty Repair Services</i> .....	Warranty-1
<i>After Warranty Service</i> .....	Warranty-1
<b>Limited Warranty (Australia Only)</b> .....	Warranty-2
<i>Repair Notice</i> .....	Warranty-2
<i>Exclusions</i> .....	Warranty-2
<i>Warranty Repair Services</i> .....	Warranty-3
<i>After Warranty Service</i> .....	Warranty-3
<b>Appendix A - Time Zone Codes</b> .....	A-1
<b>Index</b> .....	Index-1

# Welcome

The Aastra 6867i is a 9-line SIP phone designed for power users who demand a lot from both their phones and their networks. The Aastra 6867i provides remarkable HD wideband audio and an enhanced speakerphone that utilizes dual microphones and advanced audio processing to achieve richer and clearer handsfree conversations. Supporting today's high speed networks through dual Gigabit Ethernet ports, the 6867i offers a large color LCD display, 6 programmable soft keys, 4 programmable context sensitive system keys and native DHSG/EHS headset support. With its fully customizable hard key layout, XML capabilities, and an environmentally efficient PoE class 2 rating, the 6867i is one of the most advanced SIP desktop phones available on the market today.

## About this Guide

This guide explains how to use the basic features of your new 6867i phone. Not all features listed are available by default. Contact your System or Network Administrator to find out which features and services are available to you on your system. Your System Administrator has the ability to customize some features on this phone. For information on more advanced settings and configurations, Administrators should refer to the **Aastra SIP IP Phones Administrator Guide**.

## Documentation

- **Aastra 6867i SIP IP Phone Quick Reference Guide** – Contains call handling instructions, an overview of the User Interface (UI) and details on UI navigation, as well as information on other important features. The Quick Reference Guide can be downloaded from <http://www.aastra.com>.
- **Aastra 6867i SIP IP Phone Installation Guide** – Contains installation and set-up instructions, general features and functions, and basic options list customization. The Installation Guide can be downloaded from <http://www.aastra.com>.
- **Aastra 6867i SIP IP Phone User Guide** – Describes the most commonly used features and functions for an end user. The User Guide can be downloaded from <http://www.aastra.com>.
- **Aastra SIP IP Phones Administrator Guide** – Describes how to set up the Aastra SIP IP phones on the network and contains advanced configuration instructions. The Administrator Guide is intended for the System Administrator and can be downloaded from <http://www.aastra.com>.

## Phone Features

- 3.5" QVGA color TFT LCD with backlight
- Built-in, two-port 10/100/1000 Gigabit Ethernet switch – lets you share a connection with your computer
- USB 2.0 port (100mA maximum)
- 6 programmable and 4 context-sensitive softkeys
- Press-and-hold speed dial key configuration feature
- Supports up to 9 call lines with LEDs
- Wideband handset
- Wideband, full-duplex speakerphone for handsfree calls
- Headset mode support
- AC power adapter (sold separately)
- Enhanced busy lamp fields\*
- Set paging\*

\*Availability of feature dependant on your phone system or service provider.

## Requirements

The 6867i requires the following environment:

- SIP-based IP PBX system or network installed and running with a SIP account created for the 6867i phone
- Access to a Trivial File Transfer Protocol (TFTP), File Transfer Protocol (FTP), Hypertext Transfer Protocol (HTTP) server, or Hyper Text Transfer Protocol over Secure Sockets Layer (SSL) (HTTPS)
- Ethernet/Fast Ethernet LAN (10/100 Mbps) (Gigabit Ethernet LAN [1000 Mbps] recommended)
- Category 5/5e straight-through cabling (Category 6 straight-through cabling required for optimum Gigabit Ethernet performance)
- Power source:
  - For Ethernet networks that supply inline power to the phone (IEEE 802.3af) use an Ethernet cable to connect from the phone directly to the network for power (no 48V AC power adapter required if using Power-over-Ethernet [PoE])
  - For Ethernet networks that DO NOT supply power to the phone:  
Use only the GlobTek Inc. Limited Power Source [LPS] adapter model no. GT-41080-1848 (sold separately) to connect from the DC power port on the phone to a power source  
or
  - Use a PoE power injector or a PoE switch

## Installation and Setup

If your System Administrator has not already setup your 6867i phone, please refer to the **Aastra 6867i Installation Guide** for basic installation and physical setup information. For more advanced administration and configuration information, System Administrators should refer to the **Aastra SIP IP Phones Administrator Guide**.



# IP Phone Keys

## Key Panel



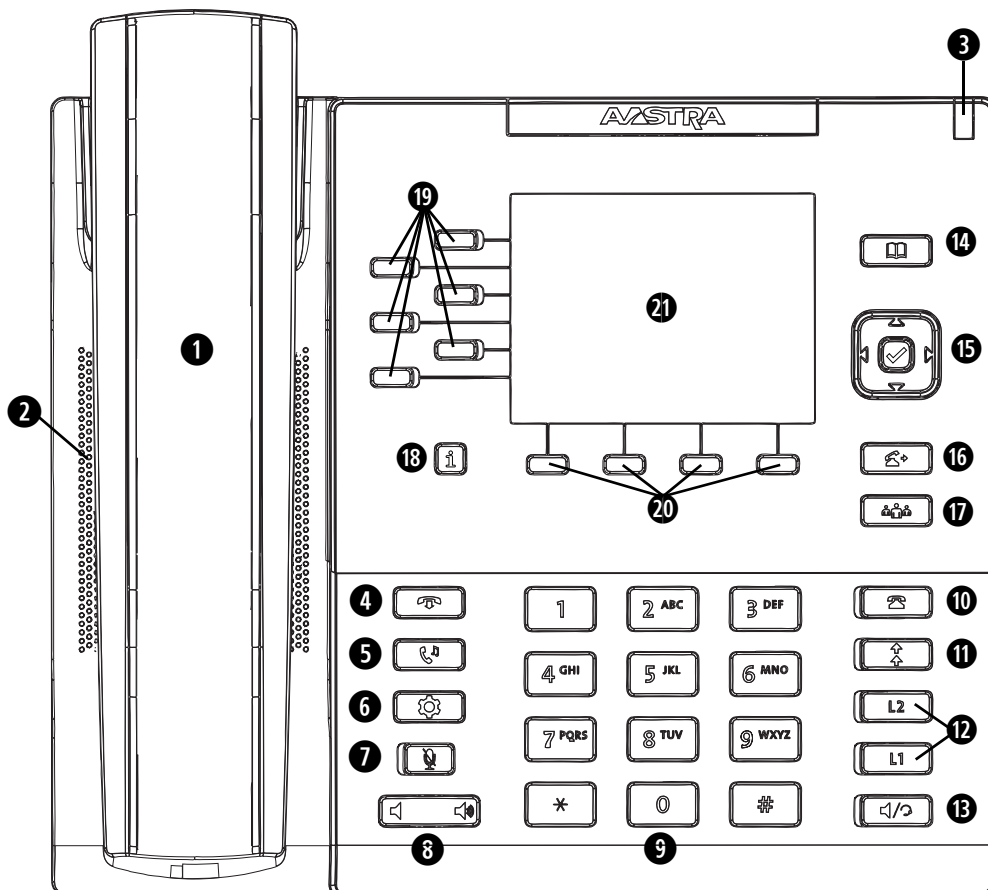







The following sections describe the various 6867i phone key functions and how they can help you make and manage your calls and caller information.



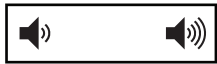

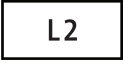
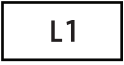



<b>1</b>	6867i Handset	<b>12</b>	Line/Call Appearance Keys
<b>2</b>	High Quality Speakerphone	<b>13</b>	Speaker/Headset Key
<b>3</b>	Message Waiting Indicator	<b>14</b>	Directory Key
<b>4</b>	Goodbye Key	<b>15</b>	Navigation Keys/Select Button
<b>5</b>	Hold Key	<b>16</b>	Transfer Key
<b>6</b>	Options Key	<b>17</b>	Conference Key
<b>7</b>	Mute Key	<b>18</b>	Presence Key
<b>8</b>	Volume Control	<b>19</b>	Programmable Softkeys
<b>9</b>	Dialpad	<b>20</b>	Context-Sensitive Softkeys
<b>10</b>	Callers List Key	<b>21</b>	TFT LCD Screen
<b>11</b>	Redial Key		

## Key Description

The following table describes the keys on the 6867i:

Key	Description
	<b>Goodbye Key</b> - Ends an active call. The <b>Goodbye</b> key also exits an open list, such as the Options List, without saving changes.
	<b>Hold Key</b> - Places an active call on hold. To retrieve a held call, press the <b>Hold</b> key again or press the <b>Pickup</b> softkey offered on the display.  For more information, see <a href="#">"Placing a Call on Hold"</a> on page 110.
	<b>Options Key</b> - Accesses services and options to customize your phone. Your System Administrator may have already customized some of your settings. Check with your System Administrator before changing any Administrator-only options.  For more information, see <a href="#">"Phone Options via the IP Phone UI"</a> on page 17.
	<b>Mute Key</b> - Mutes the microphone so that your caller cannot hear you (the light indicator flashes when the microphone is on mute).  For more information, see <a href="#">"Mute"</a> on page 108.
	<b>Volume Controls</b> - Adjusts the volume for the handset, ringer, and handsfree speakerphone.
	<b>Callers List Key</b> - Accesses a list of the last 200 calls received.  For more information, see <a href="#">"Callers List"</a> on page 130.
	<b>Redial Key</b> - Accesses a list of the last 100 previously dialed numbers. Pressing the <b>Redial</b> key twice redials the last dialed number.  For more information, see <a href="#">"Redial"</a> on page 105.
	<b>Line/Call Appearance Keys</b> - Connects you to a line or call. The Aastra 6867i IP phone has two default <b>Line</b> keys, each with LED indicator lights.  For more information, see <a href="#">"Line and Call Appearances"</a> on page 55.
	
	<b>Speaker/Headset Key</b> - Transfers the active call to the speaker or headset, allowing handsfree use of the phone.  For more information, see <a href="#">"Using Handsfree Speakerphone"</a> on page 103.
	<b>Directory Key</b> - Accesses a directory of names and phone numbers (stored in alphabetical order).  For more information, see <a href="#">"Directory"</a> on page 122.
	<b>Navigation Keys/Select Button</b> - Multi-directional navigation keys allow you to navigate through the phone's user interface. Pressing the center Select button selects/sets options and performs various actions (such as dialing out when in the Directory, Callers, and Redial Lists).  For more information, see <a href="#">"UI Navigation"</a> on page 15.
	<b>Transfer Key</b> - Transfers the active call to another number.  For more information, see <a href="#">"Transferring Calls"</a> on page 111.

Key	Description
	<p><b>Conference Key</b> - Begins a conference call with the active call.</p> <p>For more information, see <a href="#">“Conferencing Calls”</a> on <a href="#">page 116</a>.</p>
	<p><b>Presence Key</b> - Accesses the partial and full contact presence information screens, which provide more detailed information about the selected contact.</p> <p>For more information see <a href="#">“Presence Key”</a> on <a href="#">page 56</a>.</p>
 	<p><b>Left Softkeys</b> - 6 programmable keys that allow you to easily perform up to 20 specific functions and access enhanced services provided by third parties (e.g. XML applications).</p> <p>For more information see <a href="#">“Configuring Softkeys”</a> on <a href="#">page 57</a>.</p>
 	<p><b>Bottom Softkeys</b> - 4 programmable keys that support up to 18 functions. These keys also act as state-based keys allowing you to easily perform context-sensitive functions during specific states (i.e. when the phone is an idle, connected, incoming, outgoing, or busy state).</p> <p>For more information see <a href="#">“Configuring Softkeys”</a> on <a href="#">page 57</a>.</p>

## Dialpad Keys

The 6867i has a dialpad with digits from 0 through 9, a \* key, and a # key. Keys 2 through 9 contain the letters of the alphabet. The 6867i phone dialpad includes the following:

Dialpad Key	Description
0	Dials 0 Dials the Operator on a registered phone
1	Dials 1
2 ABC	Dials 2 When entering text, this key enters <b>A</b> with one press, <b>B</b> with two presses, and <b>C</b> with three presses
3 DEF	Dials 3 When entering text, this key enters <b>D</b> with one press, <b>E</b> with two presses, and <b>F</b> with three presses
4 GHI	Dials 4 When entering text, this key enters <b>G</b> with one press, <b>H</b> with two presses, and <b>I</b> with three presses
5 JKL	Dials 5 When entering text, this key enters <b>J</b> with one press, <b>K</b> with two presses, and <b>L</b> with three presses
6 MNO	Dials 6 When entering text, this key enters <b>M</b> with one press, <b>N</b> with two presses, and <b>O</b> with three presses
7 P QRS	Dials 7 When entering text, this key enters <b>P</b> with one press, <b>Q</b> with two presses, <b>R</b> with three presses, and <b>S</b> with four presses.
8 TUV	Dials 8 When entering text, this key enters <b>T</b> with one press, <b>U</b> with two presses, and <b>V</b> with three presses
9 WXYZ	Dials 9 When entering text, this key enters <b>W</b> with one press, <b>X</b> with two presses, <b>Y</b> with three presses, and <b>Z</b> with four presses.

The \* is called the star key. The # is called the number sign, pound key, or hash key, depending on one's nationality or personal preference. These can be used for special functions such as accessing voicemail. The star key and pound key functions are dependant on your country's feature availability. Contact your System Administrator for more information about available functions using these keys.

These dialpad keys can be used for any of the following on the phone:

- Dial a phone number to make a call (see ["Dialing a Number"](#) on [page 102](#))
- Enter digits or letters in the IP phone user interface
- Program a speed dial number (see ["Speed Dial Key"](#) on [page 62](#))
- Press a speed dial key (see ["Speed Dial Key"](#) on [page 62](#))
- Press the keys associated with a called Interactive Voice Response (IVR) system

# Getting Started

The 6867i must be set up and be configured prior to its first use. This section describes phone behavior and start up screens you may see when the phone is first plugged in, or when it is restarted.

## Plugging in and Starting the Phone

The 6867i automatically begins the start up sequence as soon as it is connected. The phone goes through this process the first time you plug in your phone and every time you restart your phone.

The phone displays the following startup screens.

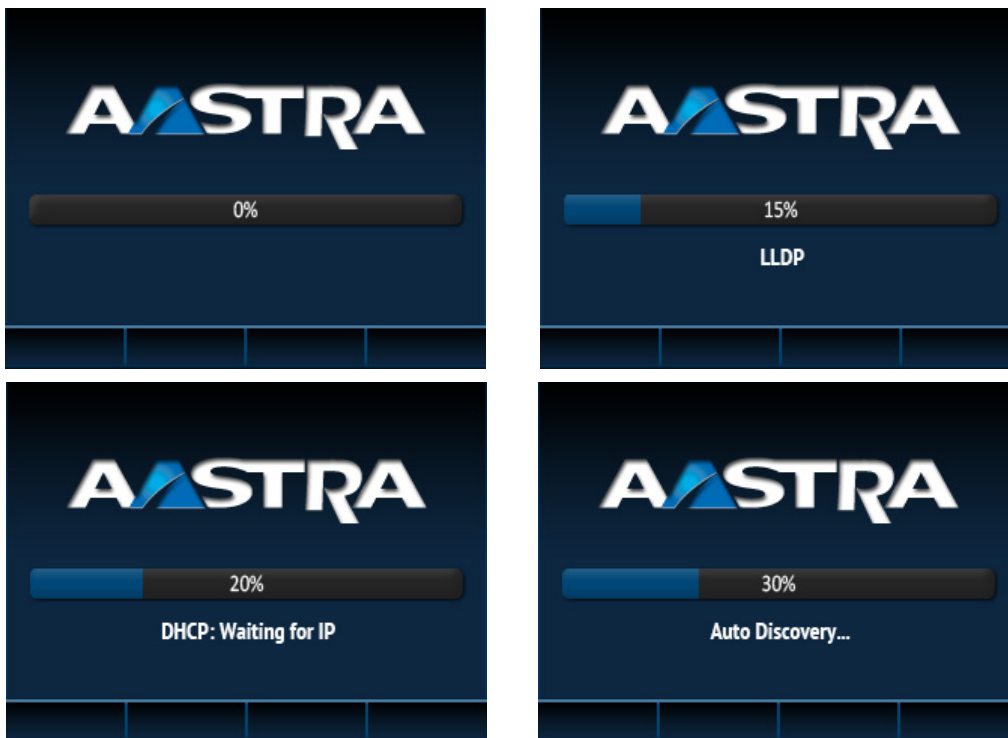

The 6867i phone then checks settings and looks for new configuration and firmware updates from a configuration server. This may take a few moments while the phone downloads the latest updates.

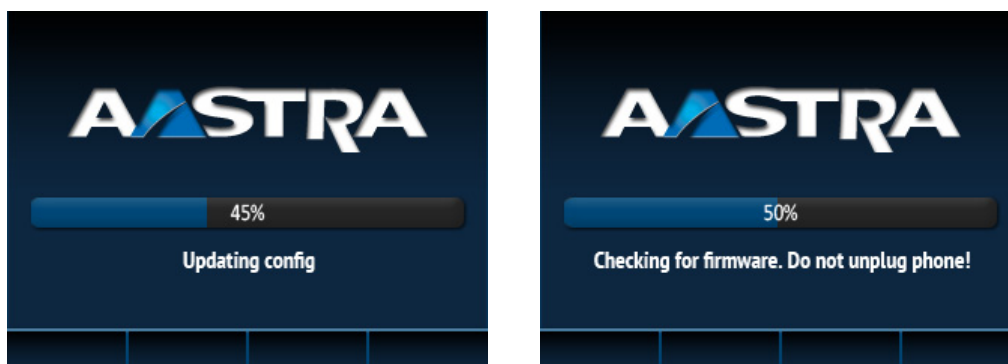

### Note:

New updates to your phone can be automatically scheduled from the server. This is set up on the phone system by your System Administrator and should be scheduled during non-business hours or slow call periods.

**Important!**

Do not unplug or remove power to the phone while it is checking or installing firmware and configuration information.

If language packs were loaded to your phone by your System Administrator, the following screen displays during startup.

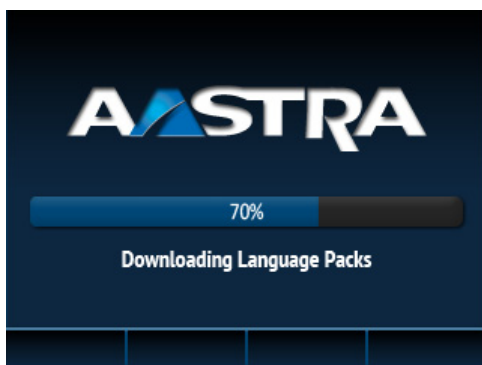

When the configuration update is complete, the phone displays the following screens and then displays the **Home** screen.

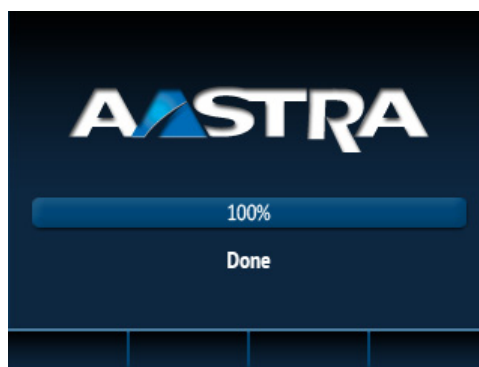
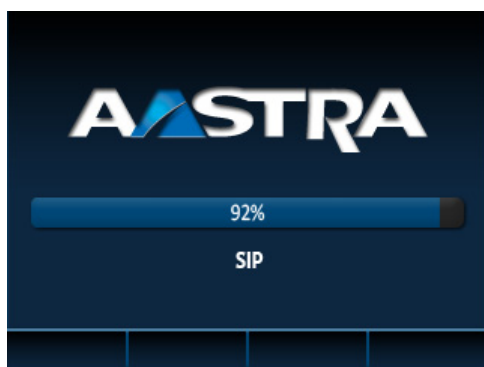
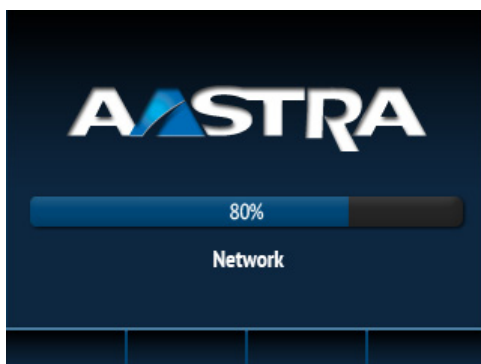

### **Network Connected/Network Disconnected**

If your phone successfully connects to the network the phone will go directly to the **Home** screen.

If your phone did not successfully connect to the network, the **Network Disconnected** prompt appears on the display and the telephone status light turns on.



Check that the cables are tightly connected to the phone and to the wall jack. The phone should automatically detect when it is reconnected and remove the **Network Disconnected** prompt from the screen. However, if changes have been made to your phone's network settings, you may need to restart your phone. Check with your System or Network Administrator for assistance.

For more information about connecting your phone, see the ***Aastra 6867i IP Phone Installation Guide***.

**Note:**

If the phone displays a **No Service** status message you can still use the phone but note that it is not registered with the Registrar. For more information about registering your phone, contact your System Administrator.

## UI Overview

### Home Screen

When the phone has successfully updated the configuration and connected to the network, the phone displays the **Home** screen. The **Home** screen displays the current line, your name (SIP screen name), the date and time, and various important status messages. It is the default screen displayed when the phone is in an idle state.



#### Note:



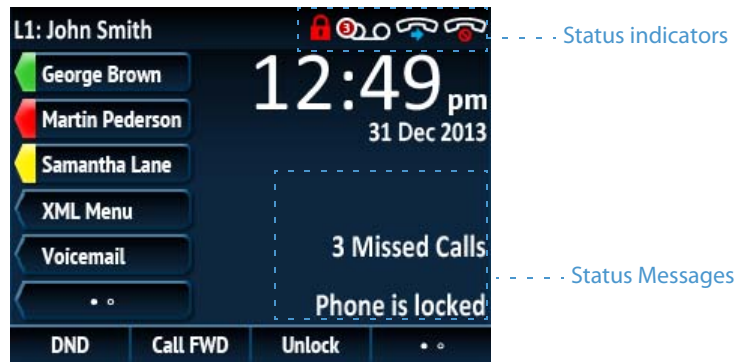

Your System Administrator should have configured your SIP screen name, line number, and any other administrative features required. If your name does not display on the screen, contact your System Administrator.

### Phone/Line Status Indicators and Messages

There are icons that display on the phone to indicate the status of the phone and/or the status of the line. These icons display on the upper right corner of the **Home** screen.



The following table identifies and describes the phone/line status indicators on the **Home** screen.

Icon	Description
	<b>Phone Locked</b> - The lock icon displays on the <b>Home</b> screen indicating that the phone is in a locked state preventing the phone from being used and preventing any changes from being made to the phone.
	<b>Voicemail</b> - The voicemail icon displays on the <b>Home</b> screen only if you have new messages waiting. The number in the red circle indicates how many new messages you have. To access your voicemail messages, use the star codes for your system if a voicemail softkey has not been configured on your phone. For more information on your system's star codes, please refer to the documentation for the voicemail system you are using.
	<b>Do Not Disturb</b> - The Do Not Disturb (DND) icon displays on the <b>Home</b> screen when the DND feature is enabled. When DND is enabled, callers calling into the phone hear a busy signal or a message, depending on the configuration.
	<b>Call Forward</b> - The Call Forward icon displays on the <b>Home</b> screen when the Call Forward feature is enabled. When Call Forward is enabled, incoming phone calls are automatically forwarded to a defined number when your phone is in a busy state and/or when the call is not answered after a specified number of rings.



In addition to the phone/line status indicators, status messages with regards to the following are displayed on the **Home** screen when the situation arises:

- Number of missed calls
- Phone lock status
- SCA Caller IDs
- XML-related text
- Network status

### Softkeys

6 left softkeys and 4 bottom softkeys are always displayed on the **Home** screen. You can configure the left softkeys with up to 20 functions and configure the bottom softkeys with up to 18 functions as required.



#### Note:

For more information about configuring the left and bottom softkeys, see [“Configuring Softkeys” on page 57](#).

If you or your Administrator have configured softkey functions on your phone, the labels for those functions display on the screen. For example, in the illustration above **XML Menu** and **Voicemail** were configured as XML and speed dial keys respectively and the remaining three left softkeys were configured as **Busy Lamp Field** (BLF) keys. The bottom set of softkeys were configured as **DND** (Do Not Disturb), **Call FWD** (Call Forward), and **Lock/Unlock** respectively.

A **More** softkey as indicated by dots is also displayed at the bottom right of the screen if you have configured more softkeys than can be displayed at one time. These dots indicate the number of softkey pages and its relative position.

### Off-Hook and Dialing Screen

When you pick up the handset on the **Home** screen, the screen displays as follows:



This screen displays the following bottom keys:

- Dial
- Conf (Conference)
- Xfer (Transfer)

These keys are context-sensitive and cannot be changed.

The **More** softkey is also displayed if you have any configured bottom softkeys. For example, in the previous figure, the 6867i has three softkeys configured that are viewable on the next softkey “page”. Pressing the **More** softkey toggles between the first and second “pages” to display all the rest of the configured softkeys (as per the figure below).

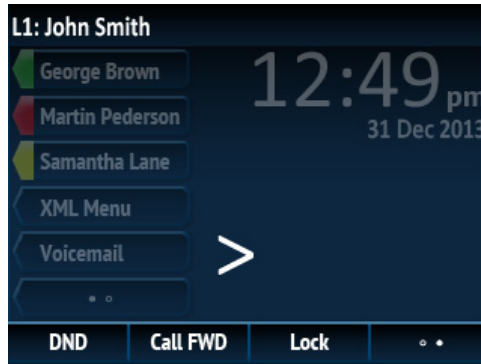



### Line Selection Screen

The **Line Selection** screen displays a list of the lines that are available on the phone as well as line usage indicators that tell you whether or not a line is in use.

It also allows you to easily select a line to act upon. When a line is not in use, a **New Call** key is available allowing you to dial out using the selected line. If the line is in use with a call on hold, a **Pickup** key is available allowing you to pick up the call on hold on the respective line.



The following table identifies and describes the line usage indicators on the **Line Selection** screen.

Indicator/Icon	Description
N/A	No icon denotes that no calls are associated with the line and the line is available to be used.
#	A number denotes how many call appearances are being utilized on the respective line.
	Indicates a call is incoming on the respective line.
	Indicates a call is outgoing on the respective line.







## Detailed-View Call Screen

The **Detailed-View Call** screen brings into focus all the information available for a specific call. It is the default screen displayed for all active point-to-point calls.



The **Detailed-View Call** screen encompasses the picture ID of the remote party (if available), a call timer indicating the duration of the call in focus (in minutes and seconds), the caller ID (name and number), and call status and feature indicators.

The following table identifies and describes the call status and call feature indicators on the **Detailed-View Call** screen.







Indicator/Icon	Description
<b>Call Status Indicators</b>	
N/A	No icon denotes that the call is connected and in progress.
	Indicates the call is on hold.
	Indicates the call is an incoming call.
	Indicates the call is an outgoing call.
	Indicates the party is a conference call participant. The direction of the arrow denotes where the other conference call participant is in the list of calls.
<b>Call Feature Indicators</b>	
	Indicates the call is secured using TLS/SRTP encryption.
	Indicates the call is using Aastra Hi-Q™ audio.
	Indicates active VoIP recording is enabled and the call is being recorded.

### Multi-View Call Screen

The **Multi-View Call** screen allows you to manage your calls more efficiently when you have more than one call in progress. It is particularly useful in transfer and conference scenarios. All pertinent information from the **Detailed-View Call** screen is also available on the **Multi-View Call** screen but information for two remote parties can be seen simultaneously.





The following table identifies and describes the call status and call feature indicators on the **Multi-View Call** screen.

Indicator/Icon	Description
<b>Call Status Indicators</b>	
N/A	No icon denotes that the call is connected and in progress.
	Indicates the call is on hold.
	Indicates the call is an incoming call.
	Indicates the call is an outgoing call.
	Indicates the party is a conference call participant. The direction of the arrow (if applicable) denotes where the other conference call participant is in the list of calls.
<b>Call Feature Indicators</b>	
	Indicates the call is secured using TLS/SRTP encryption.
	Indicates the call is using Aastra Hi-Q™ audio.
	Indicates active VoIP recording is enabled and the call is being recorded.

## UI Navigation

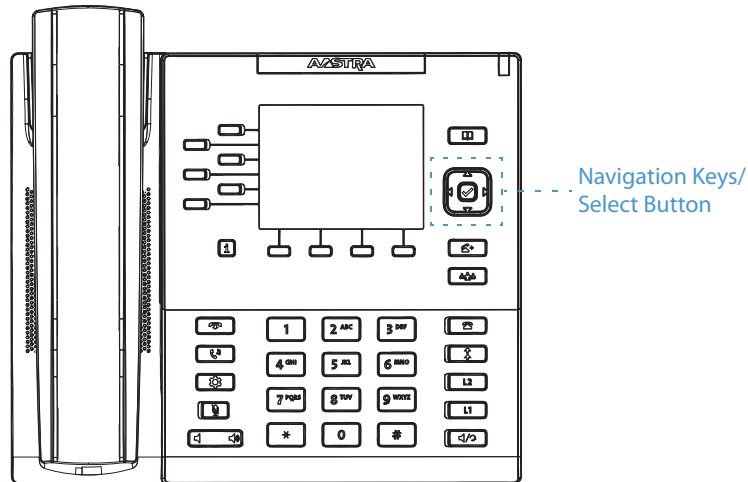
UI navigation is easily performed using the navigation keys located to the right of the LCD screen.



The ◀ and ▶ navigation keys are used to switch to the different screens and the ▲ and ▼ keys are used to highlight and scroll through the different lines/calls on the respective screen. Pressing the center  button selects/sets options and performs various actions (such as dialing out when in the Directory, Callers, and Redial Lists).

The figure below provides a visual representation of the different screens and the UI behavior when a navigation key is pressed.

**Home Screen**



**Line Selection Screen**



**Multi-View Call Screen**



**Detailed-View Call Screen**



**Note:**

The **Detailed-View Call** screen is only accessible when at least one call is in a ringing or connected state. Moreover, the **Multi-View Call** screen is only accessible when more than one call is a ringing or connected state.



# Methods of Customizing Your Phone



There are two ways to customize specific options on your phone:

- Using the **Options**  key on the IP phone
- Using the Aastra Web UI in an Internet browser window from your PC

## Phone Options via the IP Phone UI

You can customize your phone by pressing the  key and accessing the IP phone UI. These options allow you to customize the following phone settings:

Icon	Option
	<b>Status</b>
	<b>Language</b>
	<b>Time and Date</b>
	<ul style="list-style-type: none"><li>• Settings</li></ul>
	<ul style="list-style-type: none"><li>• Time Zone</li></ul>
	<ul style="list-style-type: none"><li>• Set Date and Time</li></ul>
	<b>Call Forward</b>
	<b>Lock</b>
	<ul style="list-style-type: none"><li>• Password</li></ul>
	<ul style="list-style-type: none"><li>• Phone Lock</li></ul>
	<b>Audio</b>
	<ul style="list-style-type: none"><li>• Audio Mode</li></ul>
	<ul style="list-style-type: none"><li>• Headset</li></ul>
	<ul style="list-style-type: none"><li>• Ring Tones</li></ul>
	<ul style="list-style-type: none"><li>• Tone Set</li></ul>
	<b>Display</b>
	<b>Dialpad</b>
	<ul style="list-style-type: none"><li>• Live Dialpad</li></ul>

Icon	Option
	• Speed Dial Edit
	<b>Restart</b>

**Note:**

The **Advanced** options are Administrator-level functions only, and are not accessible by the user. These options should only be set up and changed by your System Administrator.

**Simplified Options List**

Your System Administrator may configure a simplified Options List for your phone. The following table indicates the options that may appear on your phone if the simplified Options List is applied.

Icon	Option
	<b>Status</b>
	<b>Call Forward</b>
	<b>Lock</b>
	<b>Audio</b>
	• Audio Mode
	• Headset
	• Ring Tones
	• Tone Set
	<b>Display</b>
	<b>Restart</b>





## Using the IP Phone UI

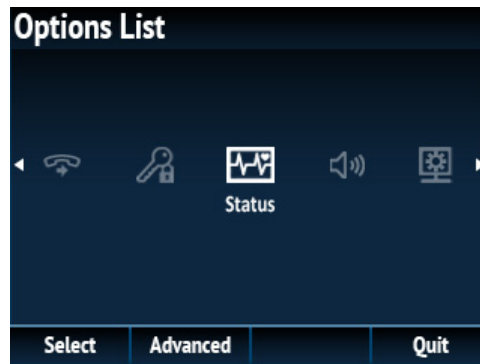

## IP Phone UI

1. Press  on the phone to enter the Options List.



2. To go to an option, use ◀ and ▶ to navigate to the main option and ▲ and ▼ to scroll through the sub options.
3. Press the  button or **Select** softkey to select an option.
4. Use the navigation keys, dialpad keys, and softkeys that display for each option to make any desired changes.
5. Press the **Save** softkey to save your changes.
6. Press the  button or the **Cancel** softkey at any time to exit without saving changes.

**Notes:**

- For more information about customizing your phone using the available options from the IP phone UI, see [“Customizing Your Phone”](#) on page 28.
- For more information about **Advanced** options, contact your System Administrator.

## Phone Options via the Aastra Web UI

In addition to the IP phone UI options, you can customize options on the IP phone using the Aastra Web UI. In order to access your phone using the Aastra Web UI, you need to know your phone's IP address. To find your phone's IP address, see "Finding Your Phone's IP Address" on page 25.

### Using the Aastra Web UI



1. Open your web browser, enter the phone's IP address or host name into the address field and press **Enter**. The following logon screen displays.



2. At the prompt, enter your username and password and click **OK**. The **Status** window displays for the IP phone you are accessing.  
**Note:**  
 For a user, the default username is "user" and the password field is left blank.

Network Status			
Attribute	LAN Port	PC Port	
Link State	Up	Down	
Negotiation	Auto	Auto	
Speed	100Mbps	10Mbps	
Duplex	Full	Half	

Hardware Information	
Attribute	Value
MAC Address:	00-11-22-33-44-55
Platform	68671 Revision 0

Firmware Information	
Attribute	Value
Firmware Version	3.3.1.5014
Firmware Release Code	SIP
Boot Version	1.0.0.0
Date/Time	May 4 2013 03:27:15

SIP Status				
Line	SIP Account	Status	Backup Registrar Used?	
1	650@proxy.com:5060	Registered	Yes	
2	651@proxy.com:5060	Registered	Yes	
3	653@proxy.com:5060	Registered	Yes	
4	654@proxy.com:5060	401	No	

3. You can logout of the Aastra Web UI at any time by clicking **Log Off**.

The following categories display in the side menu of the Aastra Web UI: **Status**, **Operation**, and **Basic Settings**.

Category	Description
Status	The <b>Status</b> section displays the network status and the MAC address of the IP phone. It also displays hardware and firmware information regarding the IP phone, and information about the SIP account(s) currently configured on the phone. The information in the <b>Status</b> window is read-only.
Operation	<p><b>User Password</b> - Allows you to change the user password.</p> <p><b>Phone Lock</b> - Allows you to assign an emergency dial plan to the phone, lock the phone to prevent any changes to the phone and to prevent use of the phone, as well as reset the user password.</p> <p><b>Softkeys and XML</b> - Allows you to configure up to 6 left softkeys and 4 bottom softkeys with functions identified in the list below.</p> <p><b>Available functions for softkeys:</b></p> <ul style="list-style-type: none"> <li>• None</li> <li>• Line</li> <li>• Speed Dial</li> <li>• Do Not Disturb (DND)</li> <li>• Busy Lamp Field (BLF)</li> <li>• BLF/List</li> <li>• Auto Call Distribution (ACD)</li> <li>• Extensible Markup Language (XML)</li> <li>• Flash</li> <li>• Sprecode</li> <li>• Park</li> <li>• Pickup</li> <li>• Last Call Return</li> <li>• Call Forward</li> <li>• BLF/Xfer</li> <li>• Speed Dial/Xfer</li> <li>• Speed Dial/Conf</li> <li>• Directory</li> <li>• Callers List</li> <li>• Redial</li> <li>• Conference</li> <li>• Transfer</li> <li>• Intercom (Icom)</li> <li>• Phone Lock</li> <li>• Paging</li> <li>• Empty</li> </ul> <p><b>Keypad Speed Dial</b> - Allows you to assign a speed dial number to a specific digit on the phone's keypad/dialpad for speed dialing purposes.</p> <p><b>Expansion Module</b> - Allows you to configure an additional 16 softkeys with a M680i Expansion Module if it is attached to the phone. This option displays on the side menu of the Aastra Web UI only if an Expansion Module is attached. Not all functions in the table above apply to the expansion modules.</p> <p><b>Directory</b> - Allows you to copy the Callers List and Directory from your IP phone to your PC.</p> <p><b>Reset</b> - Allows you to restart the IP phone when required.</p>

Category	Description
Basic Settings	<p><b>Preferences</b> - Allows you to enable/disable the following:</p> <ul style="list-style-type: none"><li>• Display DTMF Digits</li><li>• Play Call Waiting Tone</li><li>• Stuttered Dial Tone</li><li>• XML Beep Support</li><li>• Status Scroll Delay (seconds)</li><li>• Switch UI Focus to Ringing Line</li><li>• Call Hold Reminder During Active Calls</li><li>• Call Hold Reminder</li><li>• Call Waiting Tone Period</li><li>• Goodbye Key Cancels Incoming Call</li><li>• Message Waiting Indicator Line</li><li>• DND Key Mode</li><li>• Call Forward Key Mode</li></ul> <p>This category also allows you to configure:</p> <ul style="list-style-type: none"><li>• Incoming Intercom Call Settings</li><li>• Group Paging RTP Settings</li><li>• Ring Tones (global and per-line basis)</li><li>• Time and Date Settings</li><li>• Language Settings</li></ul> <p><b>Account Configuration</b> - Allows you to configure DND and Call Forward by account. You can have multiple accounts on the 6867i.</p>

---

# Phone Status

You can view the status of your phone using the IP phone UI or the Aastra Web UI.



## Phone Status via IP Phone UI

The **Status** option on the IP phone displays the status of your phone to the LCD display.

This option allows you to view your phone's:

- Firmware information including firmware version and boot version
- Network status including your phone's IP, MAC address, and LAN/PC port information
- Storage information including how many records are stored in your Directory, Callers, and Redial lists
- Error messages from the last reboot or startup
- Copyright information.



1. Press  on the phone to enter the Options List.
2. Press the  button to enter the **Status** menu.
3. Use the **▲** and **▼** keys to scroll through the following status items:
  - **Firmware Info**

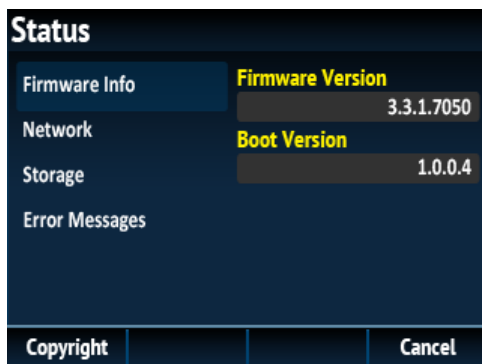

- **Network**

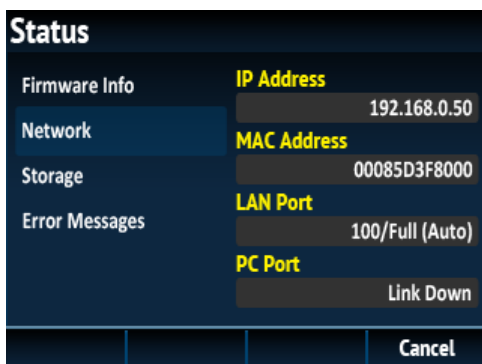

- **Storage**

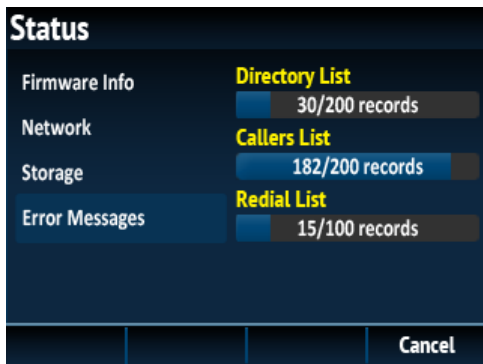

**Note:**

If the Callers List or Redial List is full, the Storage screen displays information regarding the age of the oldest record stored in memory for the respective list instead of the total number of records stored.



- **Error Messages**

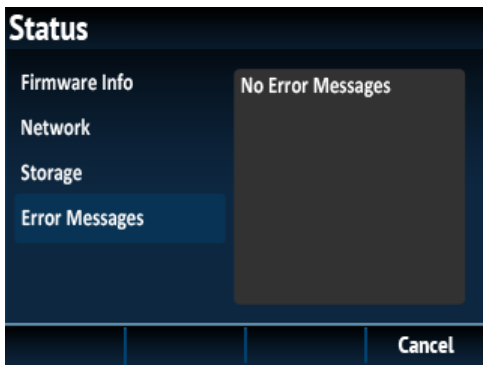

**Note:**



Press the **Copyright** softkey to view copyright information.

## Finding Your Phone's IP Address

If you want to access your phone's options using an Internet browser, you need to enter the IP address of the phone in the browser to open the Aastra Web UI. Use the following procedure to find your phone's IP address.



### IP Phone UI

1. Press  to enter the Options List.
2. Press the  button to enter the **Status** menu.

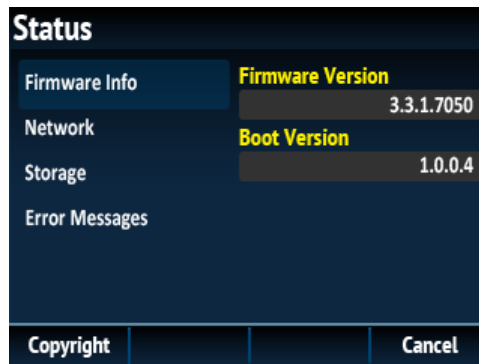

3. Use the ▼ key to highlight **Network**.  
The IP address of your 6867i displays in the **IP Address** field in the right column.

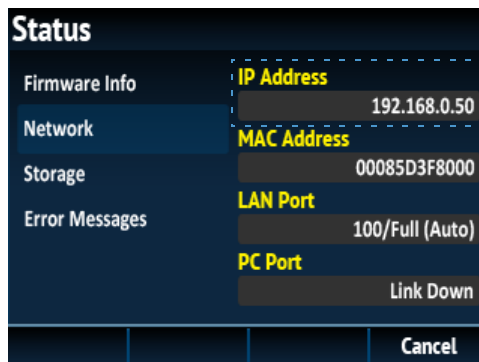

## Phone Status via the Aastra Web UI

Use the following procedure to view the phone status via the Aastra Web UI.



### Aastra Web UI

1. Open your web browser, enter the phone's IP address or host name into the address field and press **Enter**.
2. In the Username/Password window, enter your username and password and click **OK**.

The **Status** window displays for the IP phone you are accessing.

#### Note:

The default username is **user** and the password field is left blank.

The screenshot shows the Aastra Web UI interface. The top bar includes the MITEL logo and the phone ID 68671 with a Log Off button. The left sidebar contains navigation options: Status, System Information, Operation, User Password, Phone Lock, Softkeys and XML, Keypad Speed Dial, Directory, Reset, Basic Settings, Preferences, and Account Configuration. The main content area displays the following information:

#### System Information

##### Network Status

Attribute	LAN Port	PC Port
Link State	Up	Down
Negotiation	Auto	Auto
Speed	100Mbps	10Mbps
Duplex	Full	Half

##### Hardware Information

Attribute	Value
MAC Address	00-11-22-33-44-55
Platform	68671 Revision 0

##### Firmware Information

Attribute	Value
Firmware Version	3.3.1.5014
Firmware Release Code	SIP
Boot Version	1.0.0.0
Date/Time	May 4 2013 03:27:15

##### SIP Status

Line	SIP Account	Status	Backup Registrar Used?
1	650@proxy.com:5060	Registered	Yes
2	651@proxy.com:5060	Registered	Yes
3	653@proxy.com:5060	Registered	Yes
4	654@proxy.com:5060	401	No

This **Status** window displays the status of your phone, which includes the following information:

- Network Status
- Hardware Information
- Firmware Information
- SIP Status



## SIP Account Status

The IP phones show the SIP registration status on the IP phone's **Status** screen in the Aastra Web UI.

SIP Status			
Line	SIP Account	Status	Backup Registrar Used?
1	650@proxy.com:5060	Registered	Yes
2	651@proxy.com:5060	Registered	Yes
3	652@proxy.com:5060	Registered	Yes
4	653@proxy.com:5060	401	No

The following table describes the status conditions that can display for the account.

Status Condition	Description								
Registered	<p>Displays this status on accounts that HAVE been registered with the SIP proxy server.</p> <p><b>Example:</b></p> <table border="1"> <thead> <tr> <th>Line</th> <th>SIP Account</th> <th>Status</th> <th>Backup Registrar Used?</th> </tr> </thead> <tbody> <tr> <td>1</td> <td>650@proxy.com:5060</td> <td>Registered</td> <td>Yes</td> </tr> </tbody> </table> <p><b>where:</b></p> <ul style="list-style-type: none"> <li>Account Number is 1</li> <li>SIP Account is 650@proxy.com on port 5060</li> <li>Status is Registered</li> <li>Backup registrar is used (Yes)</li> </ul>	Line	SIP Account	Status	Backup Registrar Used?	1	650@proxy.com:5060	Registered	Yes
Line	SIP Account	Status	Backup Registrar Used?						
1	650@proxy.com:5060	Registered	Yes						
SIP Error Number	<p>Displays on accounts when registration fails with the SIP proxy server.</p> <p><b>Example:</b></p> <table border="1"> <thead> <tr> <th>Line</th> <th>SIP Account</th> <th>Status</th> <th>Backup Registrar Used?</th> </tr> </thead> <tbody> <tr> <td>4</td> <td>653@proxy.com:5060</td> <td>401</td> <td>No</td> </tr> </tbody> </table> <p><b>where:</b></p> <ul style="list-style-type: none"> <li>Account Number is 4</li> <li>SIP Account is 653@proxy.com on port 5060</li> <li>Status is 401 - Unregistered if SIP registration fails</li> <li>Backup registrar is used (No)</li> </ul>	Line	SIP Account	Status	Backup Registrar Used?	4	653@proxy.com:5060	401	No
Line	SIP Account	Status	Backup Registrar Used?						
4	653@proxy.com:5060	401	No						

# Customizing Your Phone

The following paragraphs describe the options available from either the IP phone UI, the Aastra Web UI, or both, and provide procedures applicable to the option.

## Language

### *IP Phone UI and Web UI Language*

The IP phones support several different languages. You can have the IP phone UI and the Aastra Web UI display in a specific language as required. When you set the language to use, all of the display screens (menus, services, options, configuration parameters, etc.) display in that language. The IP phones support the following languages:

- English
- Czech
- Catalan
- Valencian
- Welsh
- German
- Danish
- Spanish
- Mexican Spanish
- Finnish
- French
- Canadian French
- Italian
- Dutch
- Dutch (Netherlands)
- Norwegian
- Polish
- Portuguese
- Portuguese Brazilian
- Romanian
- Russian
- Slovak
- Swedish
- Turkish

### *Specifying the Language to Use Using the IP Phone UI*



Once the language pack(s) are available on your phone from your System Administrator, you can specify which language to use on the phone and/or the Aastra Web UI.

**Note:**



All languages may not be available for selection. The available languages are dependant on the language packs currently loaded to the IP phone.

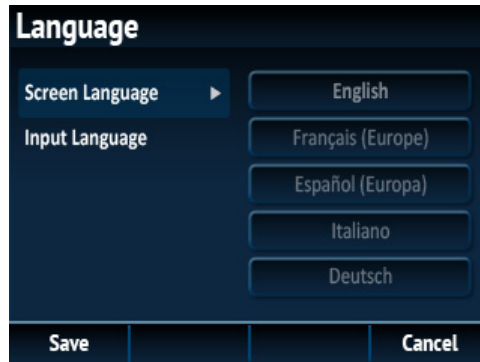

## IP Phone UI

1. Press  on the phone to enter the Options List.
2. Navigate to the **Language** option and press the  button or **Select** softkey.



3. With **Screen Language** highlighted press the  key to move to selection column.
4. Use the  and  keys to scroll through and choose the desired screen language.
 

**Note:**  
All languages may not be available for selection. The available languages are dependant on the language packs currently loaded to the IP phone. English is the default language and cannot be changed or removed. For more information about loading language packs, see your System Administrator.
5. Press the **Save** softkey to save your changes.  
The change is dynamic. When you exit the Options List, the phone and Aastra Web UI display all menu items in the language you selected.

### Specifying the Language to Use Using the Aastra Web UI



## Aastra Web UI

1. Click on **Basic Settings > Preferences > Language Settings**.

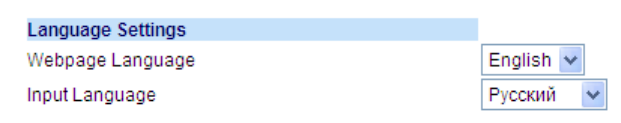

2. In the **Webpage Language** field, select a language to apply to the Aastra Web UI.
 

**Note:**  
All languages may not be available for selection. The available languages are dependant on the language packs currently loaded to the IP phone by your System Administrator. English is the default language and cannot be changed or removed.
3. Click **Save Settings**.  
The change is dynamic. The phone and the Aastra Web UI display all screens in the language you selected.

#### Note:

You must have the language pack(s) already loaded to your phone in order to use them. For more information about loading language packs, contact your System Administrator.

### Input Language

The 6867i supports text and character inputs in various languages (English, German, French, Spanish, Italian, Portuguese, Russian, and Nordic). Inputting textual or character information into the IP phone UI can be done using the dialpad on the phone. You can configure the **Input Language** feature using the Aastra Web UI or the IP phone UI.

The following tables identify the language characters that you can use to enter text and characters on the 6867i.

#### Dialpad Input Alphabet Tables

##### English

Key	Uppercase Characters	Lowercase Characters
0	0	0
1	1;=,_'&()	1.;=,_'&()
2	ABC2	abc2
3	DEF3	def3
4	GHI4	ghi4
5	JKL5	jkl5
6	MNO6	mno6
7	PQRS7	pqrs7
8	TUV8	tuv8
9	WXYZ9	wxyz9
*	* <SPACE>	* <SPACE>
#	#/\@	#/\@

##### French

Key	Uppercase Characters	Lowercase Characters
0	0	0
1	1.;=,_'&()	1.;=,_'&()
2	ABC2ÂÂÇÃÄÅÆ	abc2ââçãäåæ
3	DEF3ÉÊËË	def3éèëë
4	GHI4Ï	ghi4ïi
5	JKL5	jkl5
6	MNO6ÑÓÔÕÖ	mno6ñóôõö
7	PQRS7	pqrs7
8	TUV8	tuv8úùûü
9	WXYZ9	wxyz9
*	* <SPACE>	* <SPACE>
#	#/\@	#/\@

## Spanish

Key	Uppercase Characters	Lowercase Characters
0	0	0
1	1.;=_-'&()	1.;=_-'&()
2	ABC2ÁÀÇ	abc2áàç
3	DEF3ÉÈ	def3éè
4	GHI4Í	ghi4í
5	JKL5	jkl5
6	MNO6ÑÓÒ	mno6ñóò
7	PQRS7	pqrs7
8	TUV8ÚÛ	tuv8úü
9	WXYZ9	wxyz9
*	* <SPACE>	* <SPACE>
#	#/\@	#/\@

## German

Key	Uppercase Characters	Lowercase Characters
0	0	0
1	1.;=_-'&()	1.;=_-'&()
2	ABC2ÄÀ	abc2äà
3	DEF3É	def3é
4	GHI4	ghi4
5	JKL5	jkl5
6	MNO6Ö	mno6ö
7	PQRS7ß	pqrs7ß
8	TUV8Û	tuv8ü
9	WXYZ9	wxyz9
*	* <SPACE>	* <SPACE>
#	#/\@	#/\@

## Italian

Key	Uppercase Characters	Lowercase Characters
0	0	0
1	1.;=_-'&()	1.;=_-'&()
2	ABC2ÀÇÇ	abc2àçç
3	DEF3ÉÈÈ	def3éèè
4	GHI4	ghi4
5	JKL5	jkl5
6	MNO6ÓÒ	mno6óò
7	PQRS7	pqrs7
8	TUV8Ù	tuv8ù
9	WXYZ9	wxyz9
*	* <SPACE>	* <SPACE>
#	#/\@	#/\@

### Portuguese

Key	Uppercase Characters	Lowercase Characters
0	0	0
1	1.;=_-'&()	1.;=_-'&()
2	ABC2ÁÀÃÄÅÇ	abc2áàãäåç
3	DEF3ÉÊ	def3éê
4	GHI4Í	ghi4í
5	JKL5	jkl5
6	MNO6ÓÔÕ	mno6óôõ
7	PQRS7	pqr7
8	TUV8ÚÛ	tuv8úû
9	WXYZ9	wxyz9
*	* <SPACE>	* <SPACE>
#	#/\@	#/\@

### Russian

Key	Uppercase Characters	Lowercase Characters
0	0	0
1	1.;=_-'&()	1.;=_-'&()
2	АБВГ2ABC	абвр2abc
3	ДЕЁЖЗ3DEF	деёжз3def
4	ИЙКЛ4GHI	ийкл4ghi
5	МНОП5JKL	mnop5jkl
6	РСТУ6MNO	рсту6mno
7	ФХЦЧ7PQRS7	фхчч7pqrs
8	ШЩЪЫ8TUV	шщъы8tuv
9	ЪЗЮЯ9WXYZ	ъзюя9wxyz
*	* <SPACE>	* <SPACE>
#	#/\@	#/\@

### Nordic



Key	Uppercase Characters	Lowercase Characters
0	0	0
1	1.;=_-'&()	1.;=_-'&()
2	ABC2ĂÄÆÀ	abc2ăäæà
3	DEF3É	def3é
4	GHI4	ghi4
5	JKL5	jkl5
6	MNO6ÖØ	mno6öø
7	PQRS7ß	pqr7ß
8	TUV8Û	tuv8ü
9	WXYZ9	wxyz9
*	* <SPACE>	* <SPACE>
#	#/\@	#/\@

### Specifying the Input Language Using the IP Phone UI

You can configure the language you use for input on the phone by setting the **Input Language** option. The default input language setting is English.



#### IP Phone UI

1. Press  on the phone to enter the Options List.
2. Navigate to the **Language** option and press the  button or **Select** softkey.
3. Press the **▼** key to highlight the **Input Language** option.



4. With **Input Language** highlighted press the **▶** key to move to selection column.

Use the **▲** and **▼** keys to scroll through and choose the desired input language. Valid values are:

- English (default)
- Français (French)
- Español (Spanish)
- Deutsch (German)
- Italiano (Italian)
- Português (Portuguese)
- Русский (Russian)
- Nordic

**Note:**

Available input languages are dependent on the configuration enabled by your System Administrator.

5. Press the **Save** softkey to save your changes.  
The change is dynamic. The phone and the Aastra Web UI allow you to enter text and characters in the language you selected.

Specifying the Input Language Using the Aastra Web UI

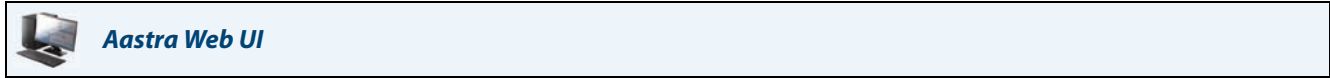

1. Click on **Basic Settings > Preferences > Language Settings**.

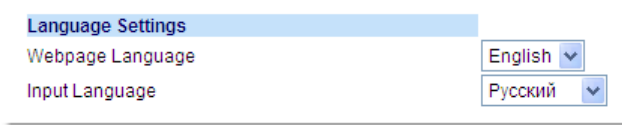

2. Select a language from the **Input Language** field. Setting this field allows you to specify the language to use when entering text and characters in the Aastra Web UI and IP phone UI. Valid values are:

- English (default)
- Français (French)
- Español (Spanish)
- Deutsch (German)
- Italiano (Italian)
- Português (Portuguese)
- Русский (Russian)
- Nordic

**Note:**

All languages may not be available for selection. The available input languages are dependant on the configuration enabled by your System Administrator.

3. Click **Save Settings**.

The change is dynamic. The phone and the Aastra Web UI allow you to enter text and characters in the language you selected.

**Latin 2 Character Set**

The 6867i includes support for ISO 8859-2 (Latin2) of multi-national languages when displaying and inputting in the IP phone UI and the Aastra Web UI. UTF-8 is also compatible with XML encoding on the IP phones.

The following table illustrates the Latin 2 character set used on the 6867i IP phone.

	-0	-1	-2	-3	-4	-5	-6	-7	-8	-9	-A	-B	-C	-D	-E	-F
A-	NBSP 00A0 160	À 0104 161	Á 02D8 162	Â 0141 163	Ã 00A4 164	Ä 013D 165	Å 015A 166	Š 00A7 167	Š 00A8 168	Š 0160 169	Š 015E 170	Š 0164 171	Š 0179 172	Š 00AD 173	Ž 017D 174	Ž 017B 175
B-	° 00B0 176	à 0105 177	á 02DB 178	â 0142 179	ã 00B4 180	ä 013E 181	å 015B 182	š 02C7 183	š 00B8 184	š 0161 185	š 015F 186	š 0165 187	š 017A 188	š 02DD 189	ž 017E 190	ž 017C 191
C-	Ř 0154 192	Á 00C1 193	Â 00C2 194	Ă 0102 195	Ä 00C4 196	Ĺ 0139 197	Ć 0106 198	Ç 00C7 199	Č 010C 200	É 00C9 201	Ę 0118 202	Ë 00CB 203	Ě 011A 204	Í 00CD 205	Î 00CE 206	Ď 010E 207
D-	Đ 0110 208	Ñ 0143 209	Ń 0147 210	Ó 00D3 211	Ô 00D4 212	Ó 0150 213	Ö 00D6 214	× 00D7 215	Ř 0158 216	Ů 016E 217	Ú 00DA 218	Ú 0170 219	Û 00DC 220	Ü 00DD 221	Ý 0162 222	Ț 00DF 223
E-	í 0155 224	á 00E1 225	â 00E2 226	ă 0103 227	ä 00E4 228	Ĺ 013A 229	ć 0107 230	ç 00E7 231	č 010D 232	é 00E9 233	ę 0119 234	ë 00EB 235	ě 011B 236	í 00ED 237	î 00EE 238	ď 010F 239
F-	đ 0111 240	ñ 0144 241	ń 0148 242	ó 00F3 243	ô 00F4 244	ó 0151 245	ö 00F6 246	÷ 00F7 247	ř 0159 248	ů 016F 249	ú 00FA 250	ú 0171 251	û 00FC 252	ü 00FD 253	ý 0163 254	ț 02D9 255



## Time and Date

On the IP phones, the following time and date sub-options are available to be configured:

- Settings:
  - Time Format
  - Daylight Savings
  - Date Format
- Time Zone
- Set Date and Time:
  - Use Network Time (configure time servers)
  - Enter Time and Date

### Note:



All time and date settings can be configured using the IP phone UI. Time/Date Formats and Time Servers are the only two time and date settings that can be configured using the Astra Web UI.

## Settings

### Configuring the Time Format, Daylight Savings, and Date Format Using the IP Phone UI



#### IP Phone UI

1. Press  on the phone to enter the Options List.
2. Navigate to the **Time and Date > Settings** option and press the  button or **Select** softkey.

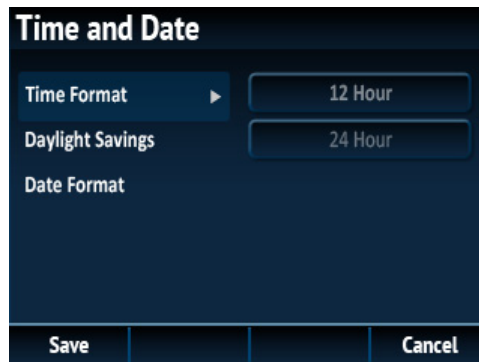

3. With **Time Format** highlighted press the ► key to move to selection column.
4. Use the ▲ and ▼ keys to scroll through and choose the desired time format. Valid values are 12 Hour and 24 Hour (the default is 12 Hour).

5. Press the ◀ key to move to back to the options column and press the ▼ key to highlight **Daylight Savings**.

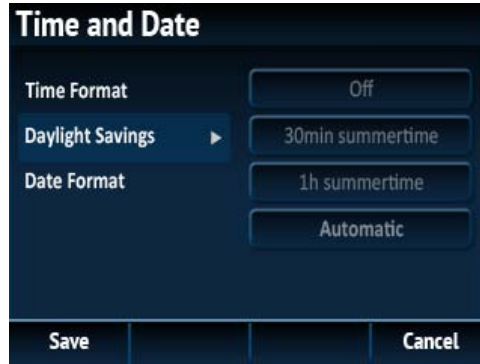

6. With **Daylight Savings** highlighted press the ► key to move to selection column.

7. Use the ▲ and ▼ keys to scroll through and choose the desired daylight savings setting. Valid values are:

- Off
- 30 min summertime
- 1h summertime
- Automatic (default)

8. Press the ◀ key to move to back to the options column and press the ▼ key to highlight **Date Format**.



9. With **Date Format** highlighted press the ► key to move to selection column.

10. Use the ▲ and ▼ keys to scroll through and choose the desired date format. Valid values are:

- WWW MMM DD (default)
- DD-MMM-YY
- YYYY-MM-DD
- DD/MM/YYYY
- DD/MM/YY
- DD-MM-YY
- MM/DD/YY
- MMM DD
- DD MMM YYYY
- WWW DD MMM
- DD MMM
- DD.MM.YYYY

11. Press the **Save** softkey to save your changes.

**Note:**



The time and date formats you configure are applicable to the **Home** screen, as well as the Callers and Redial lists.

## Time Zone

### Configuring the Time Zone Using the IP Phone UI



#### IP Phone UI

1. Press  on the phone to enter the Options List.
2. Navigate to the **Time and Date > Time Zone** option and press the  button or **Select** softkey. A list of time zones displays for different areas of the world.

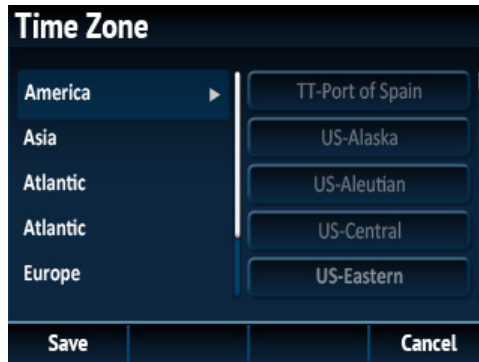

3. Use the ▲ and ▼ keys to scroll through and highlight the desired region. Valid values are:
  - America
  - Asia
  - Atlantic
  - Australia
  - Europe
  - Pacific
  - Others
4. With the desired region highlighted press the ► key to move to selection column.
5. Use the ▲ and ▼ keys to scroll through and choose the time zone that applies to your area. The default time zone is US-Eastern.
 

**Note:**  
For a list of the time zone values available on the IP phone, see [“Appendix A - Time Zone Codes.”](#)
6. Press the **Save** softkey to save your changes.

## Set Date and Time



### Configuring the Date and Time Using the IP Phone UI

With a valid time server enabled your IP phone will synchronize the time displayed with the specified configuration server. The phone will use the time from Time Server 1 unless it is not configured or unavailable, in which case it will move on to



#### IP Phone UI

Time Server 2, and if necessary Time Server 3. Alternatively, you can set the date and time manually.

1. Press  on the phone to enter the Options List.
2. Navigate to the **Time and Date > Set Date and Time** option and press the  button or **Select** softkey.

3. If you want to synchronize the time and date using a time server, ensure there is a checkmark in the box corresponding to the **Use Network Time** setting. If there is no checkmark, press the  button to enable the **Use Network Time** setting.

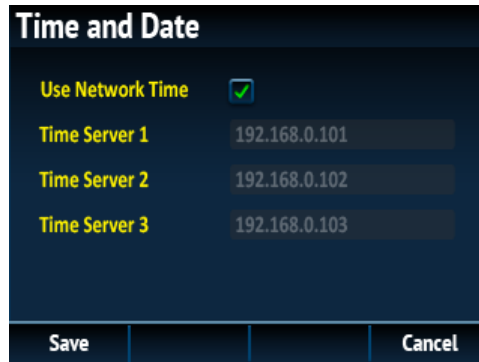

- a) Press the ▼ key to highlight **Time Server 1**, **Time Server 2**, or **Time Server 3**.
  - b) Using the keys on the dialpad, enter an IP address or domain name for the time server. Use the **Backspace** key to move back a space and delete a character. Use the **Dot** softkey to enter dots within the IP address or domain name. Use the **123 ►** softkey to toggle between entering numbers and entering letters.
4. If you want to manually set the date and time, press the  button to clear the checkmark from the **Use Network Time** box and disable the setting.



- a) Press the ▼ key to highlight **Enter Time** or **Enter Date**.
  - b) Using the keys on the dialpad, change the time and date accordingly. When entering the time, use the **AM/PM** softkey to toggle between AM and PM.
5. Press the **Save** softkey to save your changes.

## Configuring Time and Date Settings Using the Aastra Web UI



### Aastra Web UI

1. Click on **Basic Settings > Preferences > Time and Date Setting**.

Time and Date Setting	
Time Format	12h
Date Format	WWW MMM DD
NTP Time Servers	<input checked="" type="checkbox"/> Enabled
Time Server 1	0.0.0.0
Time Server 2	0.0.0.0
Time Server 3	0.0.0.0

2. In the **Time Format** field, select the time format you want to use on your phone. Valid values are:
  - 12h (12 hour format) (default)
  - 24h (24 hour format)

**Note:**

The time format you configure is applicable to the phone's **Home** screen, as well as the Callers and Redial lists.

3. In the **Date Format** field, select the date format you want to use on your phone. Valid values are:
  - WWW MMM DD (default)
  - DD-MMM-YY
  - YYYY-MM-DD
  - DD/MM/YYYY
  - DD/MM/YY
  - DD-MM-YY
  - MM/DD/YY
  - MMM DD
  - DD MMM YYYY
  - WWW DD MMM
  - DD MMM
  - DD.MM.YYYY

**Note:**

The date format you configure is applicable to the phone's **Home** screen, as well as the Callers and Redial lists.

4. In the **NTP Time Servers** field, enable the setting by checking the box or disable the setting by unchecking the box (default is enabled).
5. In the **Time Server 1**, **Time Server 2**, and **Time Server 3** fields, enter IP addresses or qualified domain names for the primary, secondary, and tertiary time servers.
 

**Note:**  
Time servers can only be entered if **NTP Time Servers** is enabled.

6. Click **Save Settings**.

## Call Forward

**Note:**

For Call Forward information and configuration details, see "Call Forward Configuration" on page 141.

## Lock

### Password



This category allows you to change the user password for your phone. Changing your password ensures that only you can alter your phone settings and helps keep your system secure. You can change your user password using the IP phone UI or the Aastra Web UI.

**Note:**

Valid values when creating or changing a password are 0 to 4294967295 (integers only; symbols and alpha characters are not allowed). The default password is an empty string (i.e. leave the field blank).

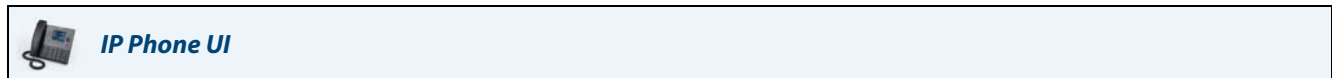
### Setting a User Password Using the IP Phone UI



1. Press  on the phone to enter the Options List.
2. Navigate to the **Lock > Password** option and press the  button or **Select** softkey.

 A screenshot of a phone's "Password" settings screen. The title "Password" is at the top. Below it are three input fields: "Current Password:", "New Password:", and "Re-enter Password:". At the bottom, there are three softkey buttons: "Save", "Backspace", and "Cancel".

3. In the **Current Password:** field, enter the current user password.
4. In the **New Password:** field, enter the new user password.
5. In the **Re-enter Password:** field, re-enter the new user password.
6. Press the **Save** softkey to save your changes.  
A **Password Changed** confirmation message displays on the screen.



### Phone Lock

You can lock your phone to prevent the phone from being used or configured. You can lock the phone using the IP phone UI, Aastra Web UI or by configuring a Lock softkey on your phone. For more information about configuring a Lock/Unlock key on your phone, see "[Phone Lock Key](#)" on [page 97](#).

### Locking the Phone Using the IP Phone UI



#### IP Phone UI

1. Press  on the phone to enter the Options List.
2. Navigate to the **Lock > Phone Lock** option and press the  button or **Select** softkey..

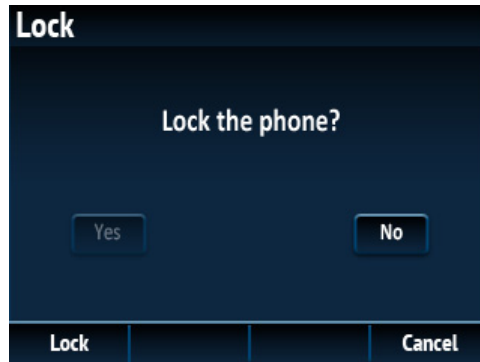

3. At the **Lock the phone?** prompt, press the **Lock** softkey or navigate to the **Yes** button and press the  button. The message **Phone is locked** and lock icon displays on the **Home** screen. Additionally the Message Waiting Indicator (MWI) will turn on.



**Note:**

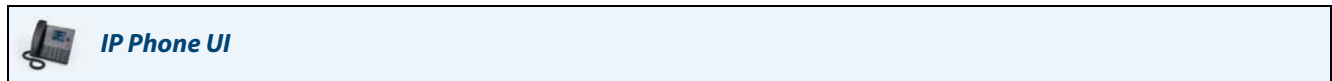

Alternatively, if configured, you can lock the phone by simply pressing a **Lock** softkey.

## Unlocking the Phone Using the IP Phone UI

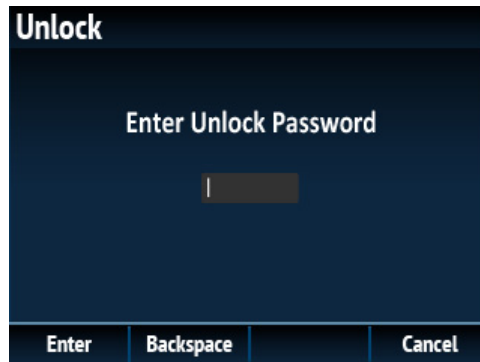

1. Press  on the phone to enter the Options List (or press a configured **Unlock** softkey).



2. At the **Enter Unlock Password** prompt, enter your user password and press the **Enter** softkey or  button.
3. At the **Unlock the phone?** prompt, press the **Unlock** softkey or navigate to the **Yes** button and press the  button.

## Configuring Lock Settings Using the Aastra Web UI

### Setting a User Password

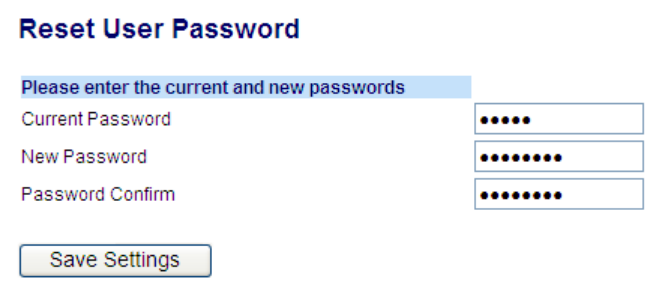

1. Click on **Operation > User Password**.

A web form titled "Reset User Password". It contains a blue header "Please enter the current and new passwords". Below this are three input fields: "Current Password" (5 dots), "New Password" (7 dots), and "Password Confirm" (7 dots). At the bottom is a "Save Settings" button.

2. In the **Current Password** field, enter the current user password.  
**Note:**  
By default, the user name is user (all lowercase) and the password field is left blank.
3. In the **New Password** field, enter the new user password.
4. In the **Password Confirm** field, enter the new user password again.
5. Click **Save Settings**.



**Resetting a User Password**

If you forget your password, you can reset it and enter a new password. The reset user password feature resets the password to the factory default which is blank (no password). You can reset a user password using the Aastra Web UI only.

**Note:**

Valid values when creating or changing a password are 0 to 4294967295 (integers only; symbols and alpha characters are not allowed). The default password is an empty string (i.e. leave the field blank).

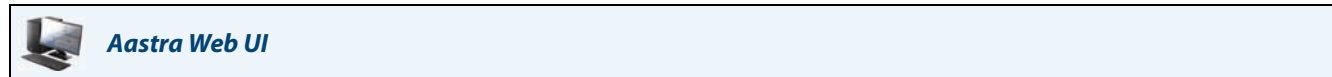

1. Click on **Operation > Phone Lock**.

2. In the **Reset User Password** field, click **Reset**.  
The following screen displays.

3. In the **Current Password** field, leave this blank.
4. In the **New Password** field, enter a new password.
5. In the **Password Confirm** field, re-enter your new user password.
6. Click **Save Settings**.

Locking and Unlocking the Phone

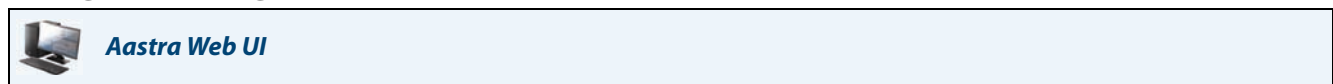

1. Click on **Operation > Phone Lock**.



**To Lock the Phone**

2. In the **Lock the Phone?** field, click **Lock**.  
The message **Phone is locked** and lock icon displays on the **Home** screen. Additionally the Message Waiting Indicator (MWI) will turn on.

**Unlocking the Phone**





3. Click on **Operation > Phone Lock**.
4. In the **Unlock the Phone?** field, click **Unlock**.

## Audio

The **Audio** option on the IP phone allows you to set the audio mode for your IP phone, configure headset settings, and personalize ring tones and tone sets.

### Audio Mode



The 6867i allows you to use a handset, a headset, or handsfree mode to handle incoming and outgoing calls. The **Audio Mode** option provides different combinations of these three methods to provide maximum flexibility in handling calls. There are four audio mode options you can set:

Audio Mode Option	Description
Speaker	This is the default setting. Calls can be made or received using the handset or handsfree speakerphone. In handset audio mode, pressing the  button on the phone switches to handsfree speakerphone. In Speaker audio mode, lift the handset to switch to the handset.
Headset	Choose this setting if you want to make or receive all calls using a handset or headset. Calls can be switched from the handset to headset by pressing the  button on the phone. To switch from the headset to the handset, lift the handset.
Speaker/Headset	Incoming calls are sent to the handsfree speakerphone first when the  button is pressed. By pressing the button again, you can switch back and forth between the handsfree speakerphone and the headset. At anytime, lifting the handset switches back to the handset from either the handsfree speakerphone or the headset.
Headset/Speaker	Incoming calls are sent to the headset first when the  button is pressed. By pressing the button again, you can switch back and forth between the headset and the handsfree speakerphone. At anytime, lifting the handset switches back to the handset from either the headset or the handsfree speakerphone.

### Configuring the Audio Mode Using the IP Phone UI



#### IP Phone UI

1. Press  on the phone to enter the Options List.
2. Navigate to the **Audio > Audio Mode** option and press the  button or **Select** softkey.

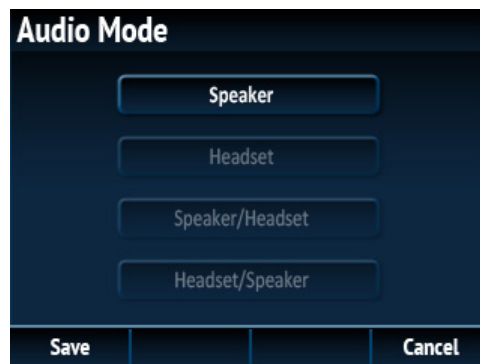



3. Use the **▲** and **▼** keys to scroll through and highlight the desired audio mode. Valid values are:
  - Speaker (default)
  - Headset
  - Speaker/Headset
  - Headset/Speaker
4. Press the **Save** softkey to save your changes.

## Headset





The **Headset** option allows you to set the volume level for the headset microphone and also allows you to enable/disable DHSG.

### Configuring Headset Mic Volume and DHSG Using the IP Phone UI

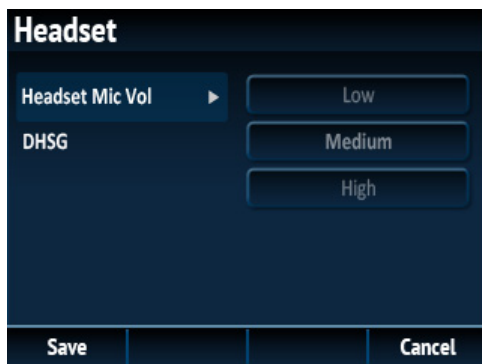



1. Press  on the phone to enter the Options List.
2. Navigate to the **Audio > Headset** option and press the  button or **Select** softkey.

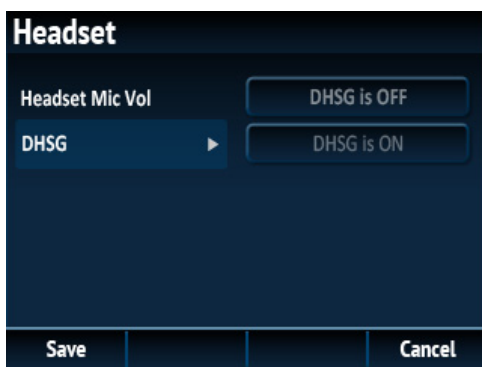

3. With **Headset Mic Vol** highlighted press the  key to move to selection column.
4. Use the  and  keys to scroll through and choose the desired volume setting. Valid values are:
  - Low
  - Medium (default)
  - High
5. Press the  key to move to back to the options column and press the  key to highlight **DHSG**.



6. With **DHSG** highlighted press the  key to move to selection column.
7. Use the  and  keys to scroll through and choose whether or not to enable DHSG. Valid values are:
  - DHSG is OFF (default)
  - DHSG is ON
8. Press the **Save** softkey to save your changes.

## Ring Tones and Tone Sets

There are several distinct ring tones a user can select from to set on the IP phones. You can enable/disable these ring tones on a global or per-line basis.

The following table identifies the valid settings and default values for each type of configuration method.

### Ring Tones

Configuration Method	Valid Values	Default Value
IP Phone UI	Global Tone 1 Tone 2 Tone 3 Tone 4 Tone 5 Silent	Global Setting: Tone 1
Aastra Web UI	Global: Tone 1 Tone 2 Tone 3 Tone 4 Tone 5 Silent	Global Setting: Tone 1
Lines 1 to 9	Per-Line Setting: Global Tone 1 Tone 2 Tone 3 Tone 4 Tone 5 Silent	Per-Line Setting: Global

In addition to ring tones, you can configure ring tone sets on a global-basis on the IP phone. Ring tone sets consist of tones customized for a specific country. The ring tone sets you can configure on the IP phones are:

- Australia
- Brazil
- Europe (generic tones)
- France
- Germany
- Italy
- Italy2
- Malaysia
- Mexico
- Russia
- Slovakia
- UK
- US (Default - also used in Canada)

When you configure the country's tone set, the country-specific tone is heard on the phone for the following:

- Dial tone
- Secondary dial tone
- Ring tone
- Busy tone
- Congestion tones
- Call waiting tone
- Ring cadence pattern



You configure global ring tones and tone sets using the IP phone UI and Aastra Web UI.

### Configuring Ring Tones Using the IP Phone UI



#### IP Phone UI

#### Global configuration only

1. Press  on the phone to enter the Options List.
2. Navigate to the **Audio > Ring Tones** option and press the  button or **Select** softkey.

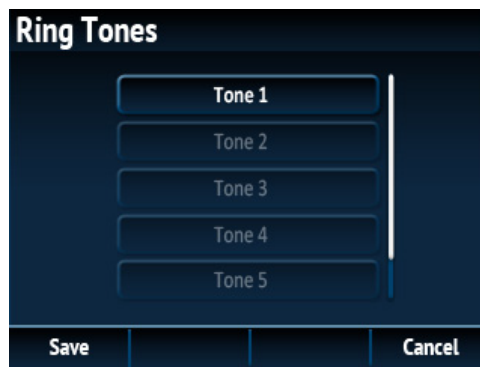



3. Use the ▲ and ▼ keys to scroll through and choose the desired ring tone (**Tone 1** through **Tone 5**, or **Silent**).
4. Press the **Save** softkey to save your changes.  
The ring tone you select is immediately applied to the IP phone.

## Configuring Tone Sets Using the IP Phone UI



### IP Phone UI

#### Global configuration only

1. Press  on the phone to enter the Options List.
2. Navigate to the **Audio > Tone Sets** option and press the  button or **Select** softkey.

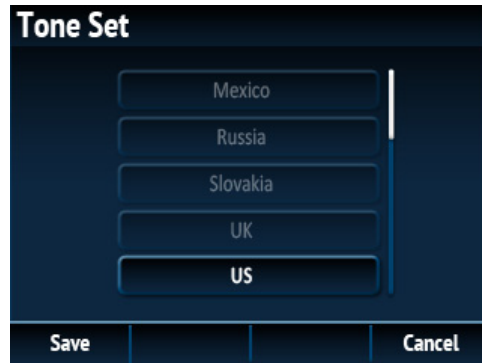

3. Use the ▲ and ▼ keys to scroll through and choose the desired tone set. Valid values are:
  - Australia
  - Brazil
  - Europe
  - France
  - Germany
  - Italy
  - Italy2
  - Malaysia
  - Mexico
  - Brazil
  - Russia
  - Slovakia
  - UK
  - US (default)
4. Press the **Save** softkey to save your changes.  
The tone set you select is immediately applied to the IP phone.

**Configuring Ring Tones and Tone Sets Using the Aastra Web UI**

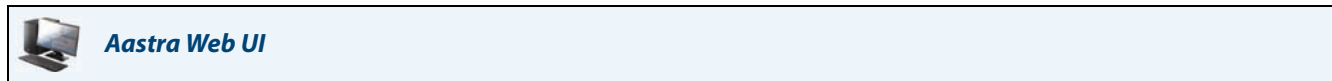

1. Click on **Basic Settings > Preferences > Ring Tones.**

Ring Tones	
Tone Set	US
Global Ring Tone	Tone 1
Line 1	Global
Line 2	Global
Line 3	Global
Line 4	Global
Line 5	Global
Line 6	Global
Line 7	Global
Line 8	Global
Line 9	Global

**For global configuration**

2. In the **Ring Tones** section, select a country from the **Tone Set** field. Valid values are:

- Australia
- Brazil
- Europe
- France
- Germany
- Italy
- Italy2
- Malaysia
- Mexico
- Brazil
- Russia
- Slovakia
- UK
- US (default)

3. Select a value from the **Global Ring Tone** field .

**Note:**  
See the “Ring Tones” on page 47 for valid values.

**For per-line configuration**

4. In the **Ring Tone** section, select a line for which you want to set ring tone.

5. Select a value from the **LineN** field .

**Note:**  
See the “Ring Tones” on page 47 for valid values.

6. Click **Save Settings.**



## Display

The **Display** option allows you to set the following on your phone:

- Brightness Level
- Brightness Timer

The **Brightness Level** option on the IP phone allows you to set the amount of light that illuminates the LCD display. Use this option to set the preference of brightness level.



The **Brightness Timer** option allows you to set the amount of time you want the LCD display to stay illuminated before turning the backlight off during a period of inactivity. For example, if you set the brightness timer to 60, when the phone reaches 60 seconds of inactivity, the LCD backlight goes off.

You can set the brightness level and timer using the IP phone UI only.

### Setting the Brightness Level and Timer Using the IP Phone UI



#### IP Phone UI

1. Press  on the phone to enter the Options List.
2. Navigate to the **Display** option and press the  button or **Select** softkey.

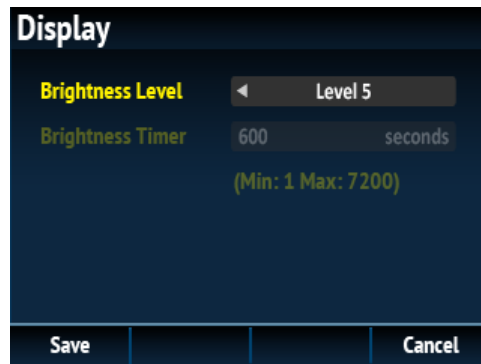

3. Use the ◀ and ▶ navigation buttons to increase or decrease the intensity of brightness on the LCD.
4. Press the ▼ key to highlight **Brightness Timer**.
5. Enter a value, in seconds, using the dialpad keys. You can set the timer from 1 to 7200 seconds. Default is 600 (10 minutes).
6. Press the **Save** softkey to save your changes.

## Dialpad

### Live Dialpad

The **Live Dialpad** option on the IP phone turns the live dialpad mode on or off. With the live dialpad feature enabled, the 6867i IP phone automatically dials out and turns on handsfree mode as soon as a dialpad key or softkey is pressed. With live dialpad disabled, if you dial a number while the phone is on-hook, lifting the receiver or pressing the  initiates a call to that number.



**Note:**

Availability of this feature is dependant on your phone system or service provider.

You can enable/disable the live dialpad using the IP phone UI only.

### Enabling/Disabling Live Dialpad Using the IP Phone UI



1. Press  on the phone to enter the Options List.
2. Navigate to the **Dialpad > Live Dialpad** option and press the  button or **Select** softkey.

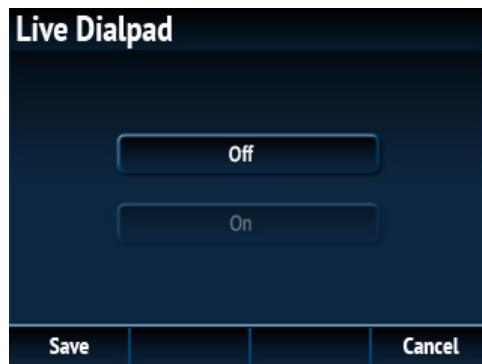

3. Use the **▲** and **▼** keys to scroll through and enable (**On**) or disable (**Off**) the live dialpad feature.
4. Press the **Save** softkey to save your changes.

### Speed Dial Edit

**Note:.**

For details on speed dial configuration, see “Speed Dial Key,” on page 62.



## Restart

You may want to restart your phone to check for updates on the server or you may occasionally need to restart your phone for configuration changes to your phone or network settings to take effect. You may also need to restart your phone if you have been asked to do so by your System Administrator or should you experience any unexpected behavior.

### Restarting Your Phone Using the IP Phone UI



#### IP Phone UI

1. Press the  button on the phone to enter the Options List.
2. Navigate to the **Restart** option and press the  button or **Select** softkey.

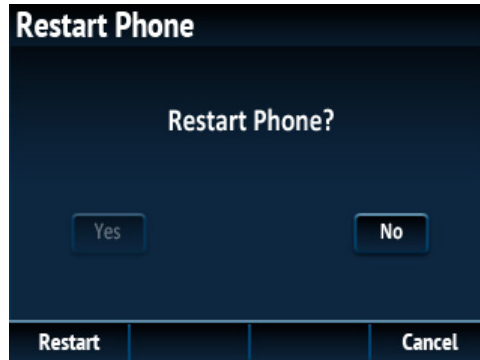

3. When the prompt, **Restart Phone?** appears, press the **Restart** softkey or navigate to the **Yes** button and press the  button.  
If you do not wish to restart your phone, press **Cancel** or **No**.

#### Note:

Your phone is out of service temporarily during the restart and reboot process.

### Restarting Your Phone Using the Aastra Web UI



#### Aastra Web UI

1. Click on **Operation > Reset**.



2. Click **Restart**.
3. Click **OK** at the confirmation prompt.

## Emergency Dial Plan

Public telephone networks in countries around the world have a single emergency telephone number (emergency services number), that allows a caller to contact local emergency services for assistance when required. The emergency telephone number may differ from country to country. It is typically a three-digit number so that it can be easily remembered and dialed quickly. Some countries have a different emergency number for each of the different emergency services.

You can specify the digits to dial on the IP phone for contacting emergency services. Once you specify the emergency number(s) on the phone, you can dial those numbers directly on the dialpad when required and the phone automatically dials to those emergency services.

You can set the emergency dial plan using the Aastra Web UI only.

**Note:**

Contact your local phone service provider for available emergency numbers in your area.

The following table describes the default emergency numbers on the IP phones.

Emergency Number	Description
911	A United States emergency number.
999	A United Kingdom emergency number.
112	An international emergency telephone number for GSM mobile phone networks. In all European Union countries it is also the emergency telephone number for both mobile and fixed-line telephones.
110	A police and/or fire emergency number in Asia, Europe, Middle East, and South America.

### Defining an Emergency Dial Plan Using the Aastra Web UI

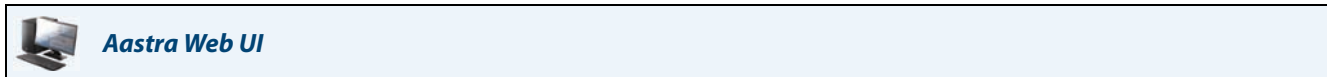

1. Click on **Operation > Phone Lock**.

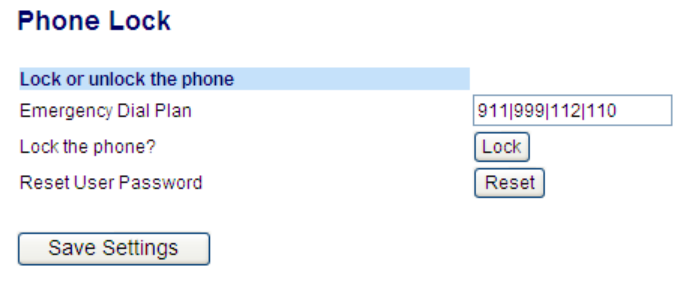

2. In the **Emergency Dial Plan** field, enter the 3-digit number used in your local area to contact emergency services. For multiple numbers, enter a | between each emergency number. For example:  
**911|110**  
 Default for this field is **911|999|112|110**.
3. Click **Save Settings** to save the emergency dial plan to your phone.

# Line and Call Appearances

The 6867i has 2 hard line/call appearance buttons each with a corresponding status light.

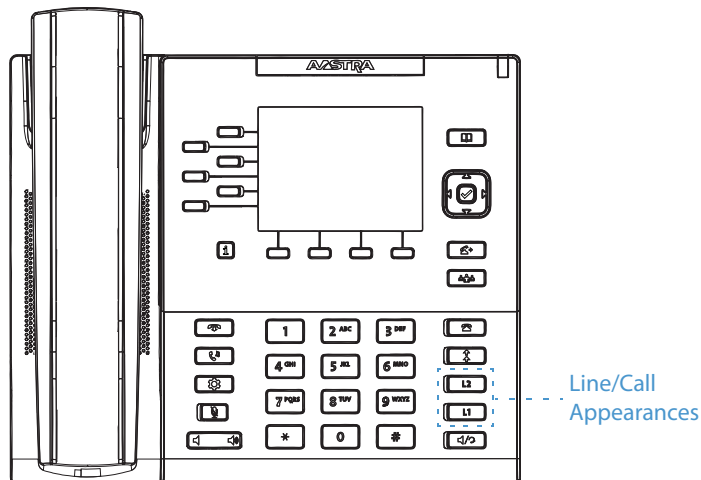

These line/call appearance buttons and lights can represent physical lines, calls for your extension, or calls from a group that your extension is part of. By pressing a line/call appearance button, you connect to the line or a call it represents. The line/call appearance light indicates the status of that line or call. When the phone is taken off-hook, the phone automatically selects a line for you.

Line/Call Appearance LED Behavior	Line/Call Appearance Status
Off	Idle line or no call activity
Light flashes quickly	Ringing
Light is solid	Connected
Light flashes slowly	Hold

When you have more than one call, you can use the ▲ and ▼ navigation keys to scroll up and down to view information for the different calls. The display shows which line the call information is referring to (L1, L2, L3, L4, etc.), picture ID and Caller ID information (name and number) if available, the call status (connected, ringing, held call, etc...), and the timer specific to that call.

# Presence Key

The **Presence**  key is used to access the contact information screens, which provide detailed information about a respective Busy Lamp Field (BLF) or Speed Dial contact.

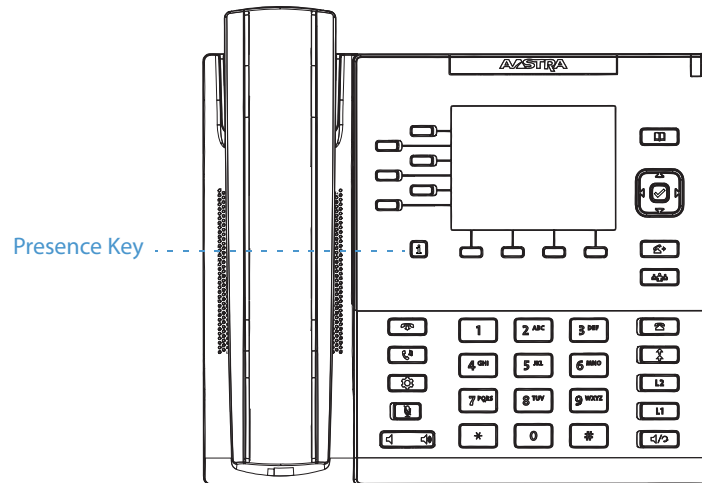

When you press the  key, you are able to view the contact's BLF details (if a BLF key is selected), Picture ID (if applicable), as well as all the phone numbers of the contact saved in your phone's memory.

## Using the Presence Key





### IP Phone UI

1. While on the **Home** Screen, press the  key.
2. Press a left softkey that is configured with BLF or Speed Dial functionality.  
The contact information screen will be displayed.



#### Note:

To switch to another contact, simply press the desired BLF or Speed Dial softkey.

3. Press the  button to place a call using the contact's default phone number.  
If you would like to place a call to a different phone number attached to the contact (if applicable), highlight the desired phone number using the ▲ and ▼ navigation keys, and press the  key.
4. Press  or the **Quit** softkey at any time to exit.

# Configuring Softkeys

Your 6867i has 6 multi-functional left softkeys and 4 multi-functional bottom softkeys:

- 6 left softkeys: programmable non-state-based softkeys (up to 20 programmable functions)
- 4 bottom softkeys: programmable state-based softkeys (up to 18 programmable functions)

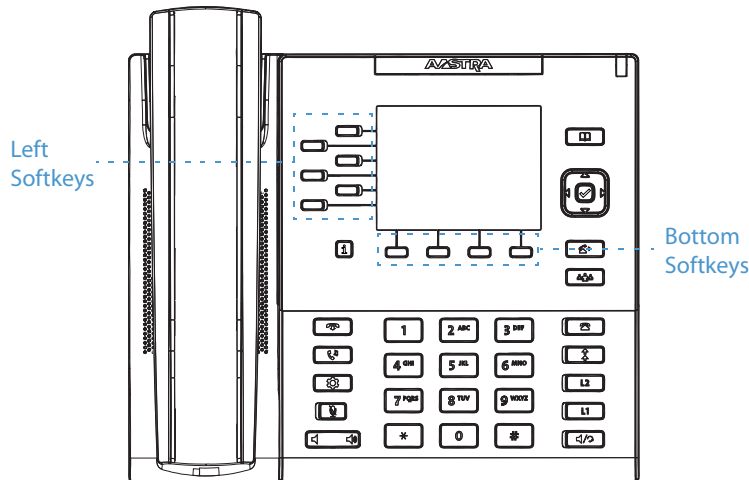

## Note:

If M680i Expansion Modules are attached to the phone, you can configure up to an additional 16 softkeys on each M680i Expansion Module. The 6867i IP phone allows up to 3 expansion modules on each phone. For more information about expansion modules, see [“Model M680i Expansion Module”](#) on page 163.

You can use the Aastra Web UI to configure key functions.

The following table lists the functions you can set on the softkeys and provides a description for each function.

Key Function	Description
None	Indicates the key has no function assigned.
Line	Indicates the key is configured for line use (programmable on the left softkeys only).
Speed Dial	Indicates the key is configured for speed dial use.
Do Not Disturb	Indicates the key is configured for Do Not Disturb (DND) functionality.
BLF	Indicates the key is configured for Busy Lamp Field (BLF) functionality (programmable on the left softkeys only).
BLF/List	Indicates the key is configured for BLF/List functionality (programmable on the left softkeys only).
Auto Call Distribution (ACD)	(For Sylanro Call Managers) Indicates the key is configured to allow the Sylanro call managers to distribute calls from a queue to registered IP phone users (agents) (programmable on the left softkeys only).
XML	Indicates the key is configured to accept an XML application for accessing customized XML services.
Flash	Indicates the key is set to generate a flash event when it is pressed. The IP phone generates flash events only when a call is connected and there is an active RTP stream (for example, when the call is not on hold).
Sprecode	Indicates the key is configured to automatically activate specific services offered by the server. For example, if the sprecode value of *82 is configured, then by pressing the Sprecode key, *82 automatically activates a service provided by the call manager.
Park	Indicates the key is configured to park incoming calls when pressed.
Pickup	Indicates the key is configured to pick up parked calls when pressed.
Last Call Return	Indicates the key is configured for Last Call Return functionality when pressed.

Key Function	Description
Call Fwd	Indicates the key is configured as a Call Forward key. When pressed, the IP phone UI displays the Call Forward menus.
BLF/Xfer	Indicates the key is configured as a simplified BLF key and a Transfer key. You can use this key to perform the BLF function as well as use it as a transfer key to transfer calls (programmable on the left softkeys only).
Speed Dial/Xfer	Indicates the key is configured as a simplified speed dial key and a transfer key. You can use this key to perform speed dial functions as well as use it as a transfer key to transfer calls.
Speed Dial/Conf	Indicates the key is configured as a speed dial key and a conference key. You can use this key to speed dial from within a conference call and add the new call directly to the conference.
Directory	Indicates the key is configured to access the Directory.
Callers List	Indicates the key is configured to access the Callers List.
Redial	Indicates the key is configured to access the Redial List.
Conference	Indicates the key is configured to initiate a conference call.
Transfer	Indicates the key is configured to initiate a call transfer.
Icom	Indicates the key is configured to be used for intercom calls.
Phone Lock	Indicates the key is configured as a phone lock key, allowing you to press this key to lock/unlock the phone.
Paging	Indicates the key is configured as a Paging key. When pressed, the phone can send Real Time Transport Protocol (RTP) streams from a pre-configured multicast address without involving SIP signalling.
Empty	Indicates the key has no function assigned but should be displayed as any empty softkey on the phone's screen.

**Note:**

Keys can also be set up to quickly access features such as call return (\*69) or voicemail. Quick access features like call return and voicemail must first be configured on your PBX in order to work on your phone. See your System Administrator for more information.



## State-Based Softkeys

On the 6867i's bottom softkeys, you can configure a specific state to display when a softkey is being used. The following table describes the states available to configure for the softkeys.

State	Description
Idle	The phone is not being used.
Connected	The current line is in an active call (or the call is on hold).
Incoming	The phone is ringing.
Outgoing	The user is dialing a number, or the far-end is ringing.
Busy	The current line is busy because the line is in use or the line is set as DND.

The following table identifies the applicable default states for each softkey type on the IP phone.

Softkey Type	Default States
None	All states disabled.
Speed Dial	Idle, Connected, Incoming, Outgoing, Busy
DND	Idle, Connected, Incoming, Outgoing, Busy
XML	Idle, Connected, Incoming, Outgoing, Busy
Flash	All states disabled.
Sprecode	Connected
Park	Connected
Pickup	Idle, Outgoing
Last Call Return	Idle, Connected, Incoming, Outgoing, Busy
Call Forward	Idle, Connected, Incoming, Outgoing, Busy
Speed Dial/Xfer	Idle, Connected, Incoming, Outgoing, Busy
Speed Dial/Conf	Idle, Connected, Incoming, Outgoing, Busy
Directory	Idle, Connected, Incoming, Outgoing, Busy
Callers List	Idle, Connected, Incoming, Outgoing, Busy
Redial	Idle, Connected, Incoming, Outgoing, Busy
Conference	Idle, Connected, Incoming, Outgoing, Busy
Transfer	Idle, Connected, Incoming, Outgoing, Busy
Intercom	Idle, Connected, Incoming, Outgoing, Busy
Phone Lock	All states disabled.
Paging	All states disabled.
Empty	Idle, Connected, Incoming, Outgoing, Busy

In the Aastra Web UI, the operational states for each softkey display as enabled. To disable a state, simply uncheck the box for the respective state.

## Softkey Display Behavior

On the 6867i IP phone, you can configure up to 20 (left) and 18 (bottom) functions on the softkeys. If you have no softkeys configured on the IP phone, and you assign softkey functions to higher number keys in the Aastra Web UI, the key functions automatically appear in the first available position on the LCD display.

For example, if left softkeys 1 through 20 are set to **None**, and you set the left softkey 12 as the following:

Type: Speed Dial

Label: Home

Value: 3456

after saving the settings, the “Home” label actually appears in position 1 of the LCD.

A softkey function of **None** does not display on the **Home** screen at all.

The following figures illustrate the above scenario (i.e. the configuration of left softkey 12) and how it is displayed on the phone:

### Aastra Web UI Configuration

**Softkeys Configuration**

Bottom Keys | Top Keys

Key	Type	Label	Value	Line
1	None			1
2	None			1
3	None			1
4	None			1
5	None			1
6	None			1
7	None			1
8	None			1
9	None			1
10	None			1
11	None			1
12	Speedial	Home	3456	1

### Corresponding 6867i Display



## Line Key

### Note:

Line functionality can only be programmed on the left softkeys.

You can set a softkey to act as a line/call appearance key on the 6867i. This key acts as a line that behaves the same as a hard line key (L1 and L2). For more information about the behavior of **Line** keys, see “Line and Call Appearances” on page 55.

Depending on how the phone has been configured, the maximum number of total line/call appearances that can be configured is 9 (2 line/call appearance hard keys plus 7 softkeys). If all line/call appearances have been set up between two different numbers, a total of 8 lines can be configured. This means that when all line/call appearances are in use, 1 call is connected while the rest are on hold. No further outgoing or incoming calls can be made until one of the line/call appearances becomes available.

### Configuring a Line Key Using the Aastra Web UI



#### Aastra Web UI

1. Click on **Operation > Softkeys and XML**.  
or  
Click on **Operation > Expansion Module <N>**.

**Softkeys Configuration**

Bottom Keys | Top Keys

Key	Type	Label	Value	Line
1	Line	Line 3		3
2	None			1
3	None			1
4	None			1
5	None			1

#### Softkeys

2. Select from **Key 1** through **Key 20** on the top keys.
3. In the **Type** field, select **Line** to apply to the key.
4. In the **Label** field, enter a label to apply to this key.
5. In the **Line** field, select a line to apply to this key.  
Valid values are **3** through **9**.

#### Expansion Module Keys

6. Select from **Key 1** through **Key 16**.
7. In the **Line** field, select a line to apply to this key.  
Valid values are **3** through **9**.
8. Click **Save Settings**.

## Speed Dial Key

The normal function of the speed dial option allows you to dial a number quickly by pressing a key configured for speed dialing. You can program the keys on the 6867i to speed dial outside numbers, dial directly to another person's line or extension, or quickly access features such as Caller ID (\*69) and voicemail.

**Note:**

You can use a **Speed Dial** key while on an active call by placing the active call on hold first, and then pressing the speed dial key.

You can create **Speed Dial** keys using any of the following methods:

- Using the Aastra Web UI at the paths:
  - *Operation > Softkeys and XML*
  - *Operation > Expansion Module Keys*
- Using the IP phone UI at the path *Options > Dialpad > Speed Dial Edit*
- By pressing and holding a softkey, dialpad key, or expansion module key.

### Speed Dial Prefix

The speed dial feature also allows you to specify a preset string of numbers followed by a + that the phone dials automatically after pressing the speed dial key. You can use this feature for numbers that contain long prefixes.

For example, if you had the following speed dial configuration in the Aastra Web UI:

Key 1  
Type: Speed Dial  
Label: Europe Office  
Value: 1234567+  
Line: 2

Then, after you press key 1 on the phone, the prefix number displays on the phone screen. The phone proceeds to dial the prefix number automatically and pauses for you to enter the remaining phone number using the dialpad on the phone.

Use the following procedures to set speed dial on the 6867i IP phone.

**Press-and-Hold to Create a Speed Dial (applicable to softkeys, dialpad keys, expansion module keys)**

Pressing and holding down a softkey, dialpad key, or expansion module key on the phone initiates a speed dial feature.

**Note:**

When creating a **Speed Dial** key from the IP phone UI, you must select a softkey, dialpad key, or expansion module key that has no preassigned function (key must be set to **None**).

**IP Phone UI**

1. Press and hold an non-configured softkey, dialpad key, or expansion module key for three seconds.

**Softkey/Expansion Module Key Speed Dial Edit Menu**
**Dialpad Key Speed Dial Edit Menu**
**Note:**

You can press the **Cancel** softkey at any time during the speed dial programming to cancel and not save the speed dial information.

2. In the **Label** field (if applicable), enter a label to apply to the key.
  - Note:** If necessary, use the **ABC ►** softkey to specify uppercase letters or lowercase letters when entering the label.
3. Press the **▼** key to move to the **Number** field (if applicable) and enter a number for the speed dial key using the dialpad keys.
4. Press the **▼** key to move to the **Line** field and select a line to apply to the key. This is the line that the phone opens to dial the number after you press the respective **Speed Dial** key. By default, the phone uses Line 1 for the **Speed Dial** key. If you want to use a different line, press the **◀** or **▶** keys to select another line.
5. Press the **Save** softkey to save the speed dial information to the key you selected.

## Creating a Dialpad Speed Dial Key Using the Speed Dial Edit Option

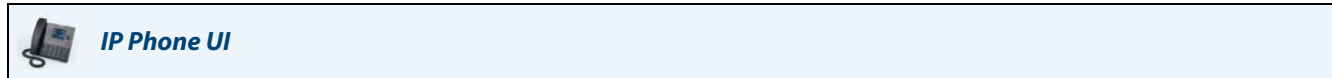

1. Press  on the phone to enter the Options List.

Navigate to the **Dialpad > Speed Dial Edit** option and press the  button or **Select** softkey.



**Note:**

You can press the **Cancel** softkey at anytime during the speed dial programming to cancel and not save the speed dial information.

2. Navigate to the desired dialpad key (by pressing the ▼ key) and in the **Number** field, enter a number for the key using the dialpad keys.
3. Press the ▼ key to move to the **Line** field and select a line to apply to the key. This is the line that the phone opens to dial the number after you press the respective **Speed Dial** key. By default, the phone uses Line 1 for the **Speed Dial** key. If you want to use a different line, press the ◀ or ▶ keys to select another line.
4. Press the **Save** softkey to save the speed dial information to the key you selected.

## Creating a Speed Dial Softkey Using the Aastra Web UI



### Aastra Web UI

1. Click on **Operation > Softkeys and XML.**  
or  
Click on **Operation > Expansion Module <N>.**

#### Softkeys Configuration

Bottom Keys		Top Keys			
Key	Type	Label	Value	Line	
1	Speeddial	Home	9051234567	1	
2	None			1	
3	None			1	
4	None			1	
5	None			1	

#### Softkeys

2. Select from **Key 1** through **Key 20** on the Top keys.  
or  
Select from **Key 1** through **Key 18** on the Bottom keys.
3. In the **Type** field, select **Speed Dial** to apply to the key.
4. In the **Label** field, enter a label to apply to this key.
5. In the **Value** field, enter the phone number, extension, or speed dial prefix to apply to this key. If you enter a speed dial prefix, you must enter the + character at the end of the prefix number (for example, 123456+).
6. In the **Line** field, select a line to apply to this key. Valid values are **1** through **9**.
7. In the state fields, check (enable) or uncheck (disable) the states you want to apply to this softkey.

#### Expansion Module Keys

8. Select from **Key 1** through **Key 16**.
9. In the **Type** field, select **Speed Dial** to apply to the key.
10. In the **Value** field, enter the phone number, extension, or speed dial prefix to apply to this key. If you enter a speed dial prefix, you must enter the + character at the end of the prefix number (for example, 123456+).
11. In the **Line** field, select a line to apply to this key. Valid values are **1** through **9**.
12. Click **Save Settings**.

Creating Dialpad Speed Dial Keys Using the Aastra Web UI



1. Click on **Operation > Keypad Speed Dial**.

**Keypad Speed Dial**

Key	Value	Line
1	9051234567	1
2		1
3		1
4		1
5		1
6		1
7		1
8		1
9		1

Save Settings

2. Select a key from **1** through **9**.
3. In the input box, enter the phone number, extension, or speed dial prefix to apply to this digit key. If you enter a speed dial prefix, you must enter the + character at the end of the prefix number (for example, 123456+).
4. In the **Line** field, select a line for which to apply the speed dial to. Valid values are **1** through **9**.
5. Click **Save Settings**.



## Do Not Disturb (DND) Key

The IP phones have a feature you can enable called Do Not Disturb (DND). Configuring a DND softkey allows you to quickly turn the DND feature on or off.

If DND is enabled, callers calling into the phone hear a busy signal or a message, depending on how your System Administrator set up the configuration server. When DND is enabled, the  icon is displayed on screen.

If the phone shares a line with other phones, only the phone that has DND configured is affected.

For more information about DND and DND modes, see “DND Configuration” on page 137.

### Configuring a DND Key Using the Aastra Web UI



#### Aastra Web UI

1. Click on **Operation > Softkeys and XML**.

or

- Click on **Operation > Expansion Module <N>**.

**Softkeys Configuration**

Bottom Keys | Top Keys

Key	Type	Label	Value	Line
1	Do Not Disturb			1
2	None			1
3	None			1
4	None			1
5	None			1

#### Softkeys

2. Select from **Key 1** through **Key 20** on the Top keys.

or

- Select from **Key 1** through **Key 18** on the Bottom keys.

3. In the **Type** field, select **Do Not Disturb** to apply to the key.

4. In the state fields, check (enable) or uncheck (disable) the states you want to apply to this softkey.

#### Expansion Module Keys

5. Select from **Key 1** through **Key 16**.

6. In the **Type** field, select **Do Not Disturb** to apply to the key.

7. Click **Save Settings**.

## Busy Lamp Field (BLF) Key

**Notes:**

- BLF functionality can only be programmed on the left softkeys.
- BLF feature availability is dependant on your call manager. Contact your System Administrator for more information.

The BLF feature on the IP phones allows a specific extension to be monitored for state changes. BLF monitors the status (busy or idle) of extensions on the IP phone.

For example, a Supervisor configures BLFs on his phone for monitoring the status of a co-worker’s phone use (busy or idle). If the co-worker’s phone is in an idle state, the **BLF** softkey on the Supervisor’s phone is green. If the co-worker is on a call or when the co-worker picks up his phone to make a call, the **BLF** softkey on the Supervisor’s phone turns red, indicating that the worker’s phone is in use and busy. Additionally, the corresponding softkey LED illuminates to match the monitored user’s state, either off (idle), or solid (busy).

**Note:**

You can also use a BLF-configured key to automatically dial the BLF-monitored extension. Contact your System Administrator for more information.

### Configuring a BLF Key Using the Aastra Web UI

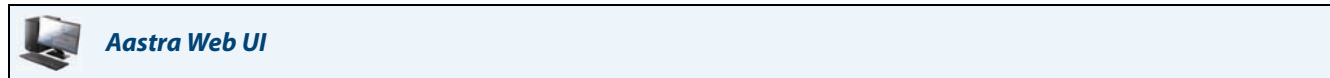

1. Click on **Operation > Softkeys and XML**.  
or  
Click on **Operation > Expansion Module <N>**.

**Softkeys Configuration**

Bottom Keys | Top Keys

Key	Type	Label	Value	Line
1	BLF	Martha	4000	1
2	None			1
3	None			1
4	None			1
5	None			1

**Softkeys**

2. Select from **Key 1** through **Key 20** on the Top keys.
3. In the **Type** field, select **BLF** to apply to the key.
4. In the **Label** field, enter a label to apply to this key.
5. In the **Value** field, enter the phone number or extension you want to monitor.
6. In the **Line** field, select a line for which to apply this key. Valid values are:
  - global
  - 1 through 9

**Expansion Module Keys**

7. Select from **Key 1** through **Key 16**.
8. In the **Value** field, enter the phone number or extension you want to monitor.
9. In the **Line** field, select a line for which to apply this key. Valid values are:
  - global
  - 1 through 9
10. Click **Save Settings**.

## BLF/List Key

### Notes:

- BLF/List functionality can only be programmed on the left softkeys.
- For use with the BroadSoft BroadWorks Release 13 or higher platform only. Your System Administrator must have BLF/List enabled on the BroadWorks call manager. Contact your System Administrator for more information.

The BLF/List feature on the IP phones is specifically designed to support the BroadSoft BroadWorks Release 13 Busy Lamp Field feature.

This feature allows the IP phone to subscribe to a list of monitored users defined through the BroadWorks web portal.

In addition to monitoring the idle and busy state, the BLF/List feature also supports the ringing state. When the monitored user is idle, the corresponding softkey is green. When the monitored user's phone is ringing, the corresponding softkey turns yellow. Finally, when the monitored user on an active call or is attempting to make a call, the corresponding softkey turns red. Additionally, the corresponding softkey LED illuminates to match the monitored user's state, either off (idle), flashing (ringing), or solid (busy).

### Notes:

- You can use a BLF/List-configured key to automatically dial out to the configured extension.
- The BroadWorks BLF feature is not the same as the BroadWorks Shared Call Appearance (SCA) feature and does not permit call control over the monitored extension.

### Configuring a BLF/List Key Using the Aastra Web UI

If you set a key to use BLF/List, you must also enter a **BLF List URI** at *Operation > Softkeys and XML > Services*. The **BLF List URI** is the name of the BLF list defined on the BroadSoft BroadWorks Busy Lamp field page for your particular user. For example, sip:9@192.168.104.13. The value of the **BLF List URI** parameter must match the list name configured. Otherwise, no values display on the 6867i screen and the feature is disabled.



#### Aastra Web UI

1. Click on **Operation > Softkeys and XML**.  
or  
Click on **Operation > Expansion Module <N>**.

**Softkeys Configuration**

Bottom Keys | Top Keys

Key	Type	Label	Value	Line
1	BLF/List			1
2	None			1
3	None			1
4	None			1
5	None			1

**Services**

XML Application URI:

XML Application Title:

BLF List URI:

### Softkeys

2. Select from **Key 1** through **Key 20** on the Top keys.
3. In the **Type** field, select **BLF/List** (BroadSoft BroadWorks).

4. In the **Line** field, select a line number that is actively registered to the appropriate SIP proxy you are using. Valid values are:

- global
- 1 through 9

**Note:**

The **Label** and **Value** field are not required. The BroadWorks BLF/List name is configured in the **BLF List URI** field instead.

5. In the state fields, check (enable) or uncheck (disable) the states you want to apply to this softkey.

6. In the **BLF List URI** field, enter the name of the BLF list defined on the BroadSoft BroadWorks Busy Lamp field page for your particular user. For example, sip:9@192.168.104.13.

**Note:**

Contact your System Administrator for the **BLF List URI**.

### *Expansion Module Keys*

7. Select from **Key 1** through **Key 16**.

8. In the **Line** field, select a line for which to apply this key. Valid values are:

- global
- 1 through 9

**Note:**

The **Value** field is not required. The BroadWorks BLF/List name is configured in the **BLF List URI** field instead.

9. In the **BLF List URI** field, enter the name of the BLF list defined on the BroadSoft BroadWorks Busy Lamp field page for your particular user. For example, sip:9@192.168.104.13.

**Note:**

Contact your System Administrator for the **BLF List URI**.

10. Click **Save Settings**.

## Automatic Call Distribution (ACD) Key (for Sylanro Call Managers)

### Note:

ACD functionality can only be programmed on the left softkeys.

The 6867i and any attached expansion modules support Automatic Call Distribution (ACD) for Sylanro call managers. The ACD feature allows the Sylanro call manager to distribute calls from a queue to registered IP phone users (agents).

To use the ACD feature on an IP phone, you must first configure an **ACD** softkey or expansion module key. When you want to subscribe to a queue (in order to receive incoming calls), you press the **ACD** softkey and the IP phone UI prompts you to log in.

**Available/Unavailable** is displayed indicating the current status of the IP phone (specifies if the IP phone user is available/unavailable to receive a call from the queue).

Additionally, the **ACD** softkey indicates your current ACD status turning from red (logged out) to yellow (logged in but unavailable) to green (logged in and available), and the corresponding LED also changes as per the table below:

Status: Logged In and Available	Status: Logged In and Unavailable	Logged Out
Solid Red LED	Blinking Red LED	No LED

When you are on an active call, or you miss a call, the server automatically changes the phone's status to unavailable. The server updates its database with this new information and no longer distributes calls to the phone. The phone remains in this unavailable state until:

- You make yourself available again by pressing the **Avail** softkey
- An ACD timer expires (set by your System Administrator)

You can also choose to manually change the phone status to unavailable by pressing the **Unavail** softkey on the phone.

### Note:

It is recommended you configure no more than a single **ACD** softkey or expansion module key per IP phone.

### Configuring an Automatic Call Distribution (ACD) Key Using the Aastra Web UI



#### Aastra Web UI

1. Click on **Operation > Softkeys and XML**.  
or  
Click on **Operation > Expansion Module <N>**.

**Softkeys Configuration**

Bottom Keys | **Top Keys**

Key	Type	Label	Value	Line
1	Auto call distribution	Sales-Queue		1
2	None			1
3	None			1
4	None			1
5	None			1

### Softkeys

2. Select from **Key 1** through **Key 20** on the Top keys.
3. In the **Type** field, select **Auto call distribution**.
4. In the **Label** field, enter a label to apply to this ACD key.

5. In the **Line** field, select a line to apply Automatic call distribution. Valid values are **1** through **9**.

### Expansion Module Keys

6. Select from **Key 1** through **Key 16**.

7. In the **Line** field, select a line to apply Automatic call distribution. Valid values are **1** through **9**.

8. Click **Save Settings**.

### Utilizing the ACD Feature Using the IP Phone UI



#### IP Phone UI

1. Check with your Administrator to verify the queue linked to your ACD softkey.
2. Press the **ACD** softkey on your IP phone.

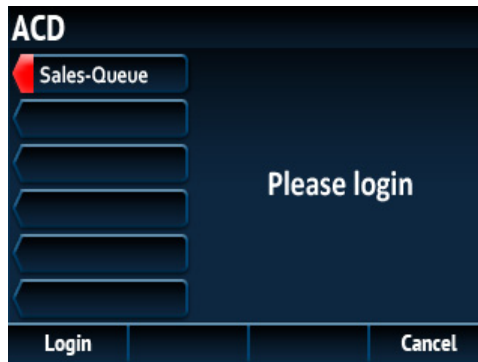

3. Press the **Login** softkey.  
Your phone logs into the queue on the server.

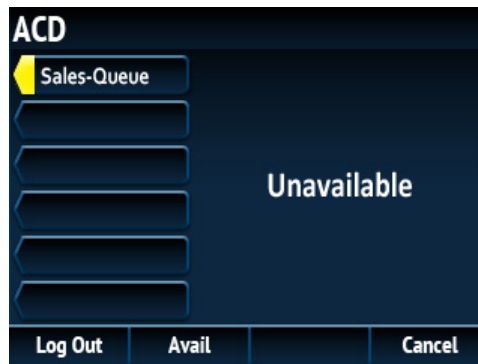

4. To allow your phone to be available in the queue, press the **Avail** softkey. The following screen displays.

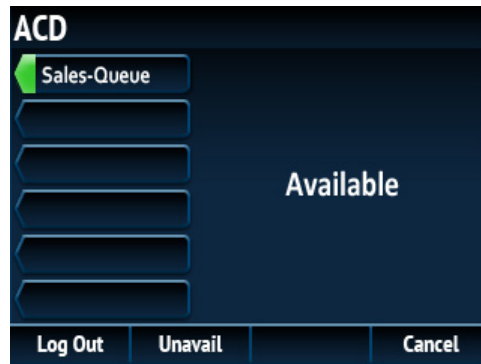

If your IP phone status is set to **Available** then the server begins to distribute phone calls from this queue to your IP phone. You must manually change the state to **Available** in order to start receiving calls.

5. To temporarily stop receiving calls, press the **Unavail** softkey. If you are on a call (or miss a call that has been distributed to your phone), your phone status automatically changes to **Unavailable**. Your phone remains in the **Unavailable** state until one of the following occurs:
  - You use the IP phone UI to manually switch the IP phone state back to **Available**  
or
  - The availability timer for your IP phone expires. This only occurs if your Administrator has configured an auto-availability timer on your IP phone. Contact your System Administrator for more information.
6. To logout of the queue, press the **Log Out** softkey. The server no longer distributes phone calls to your IP phone.

## XML Key

The 6867i IP phone has a feature you can enable called XML (Extensible Markup Language). XML is a markup language much like HTML. Your System Administrator can create customized XML menu services and load them to your IP phone. These services include things like weather and traffic reports, contact information, company info, stock quotes, or custom call scripts.

**Note:**

The XML services must be set up by your System Administrator before you can use the key.

On the 6867i IP phone, you can access the XML applications from the IP phone UI via an **XML** softkey.

Using the Aastra Web UI, you can configure a key to access XML applications. Under *Operations > Softkeys and XML*, or *Operations > Expansion Module*, you can assign a key the type **XML**.

### Configuring an XML Key Using the Aastra Web UI

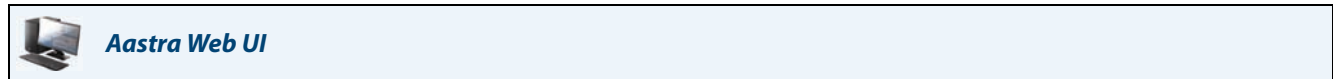

1. Click on **Operation > Softkeys and XML**.  
or  
Click on **Operation > Expansion Module <N>**.

**Softkeys Configuration**

Bottom Keys | Top Keys

Key	Type	Label	Value	Line
1	XML	XML		1
2	None			1
3	None			1
4	None			1
5	None			1

**Services**

XML Application URI: 
  
XML Application Title: 
  
BLF List URI:

### Softkeys

2. Select from **Key 1** through **Key 20** on the Top keys.  
or  
Select from **Key 1** through **Key 18** on the Bottom keys.
3. In the **Type** field, select **XML**.
4. In the **Label** field, enter a label to apply to this key.
5. In the **Value** field, enter a URI(s) to apply to this key.  
**Note:**  
Contact your System Administrator for the appropriate value(s) to enter in the **Value** field.
6. In the state fields, check (enable) or uncheck (disable) the states you want to apply to this softkey.

### Expansion Module Keys

7. Select from **Key 1** through **Key 16**.
8. In the **Type** field, select **XML**.



9. In the **Value** field, enter a URI(s) to apply to this key.

**Note:**

Contact your System Administrator for the appropriate value(s) to enter in the **Value** field.

10. Click **Save Settings**.

### ***Accessing the XML Service Using the IP Phone UI***

After an XML application(s) has been saved to your IP phone and a key has been configured to access the XML applications, the customized service is ready for you to use.



#### ***IP Phone UI***

1. Press the **XML** softkey on the 6867i phone. An XML screen displays.
2. Use the ▲ and ▼ to scroll through the customized features.
3. For menu and directory services, select a service to display the information for that customized service. Message services display to the screen after pressing the respective key. For user input services, follow the on-screen prompts.
4. To exit from the XML screen, press the **XML** softkey again or press the  button.

## Flash Key

You can set a key to generate a flash event when it is pressed on the 6867i. You do this by setting the key to **Flash**. The IP phone generates flash events only when a call is connected and there is an active RTP stream (for example, when the call is not on hold).

### Configuring a Flash Key Using the Aastra Web UI

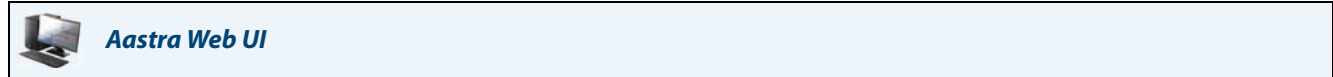

1. Click on **Operation > Softkeys and XML**.  
or  
Click on **Operation > Expansion Module <N>**.

**Softkeys Configuration**

Bottom Keys | **Top Keys**

Key	Type	Label	Value	Line
1	Flash	Flash		1
2	None			1
3	None			1
4	None			1
5	None			1

#### Softkeys

2. Select from **Key 1** through **Key 20** on the Top keys.  
or  
Select from **Key 1** through **Key 18** on the Bottom keys.
3. In the **Type** field, select **Flash**.
4. In the **Label** field, enter a label to display on the phone for the key.

#### Expansion Module Keys

5. Select from **Key 1** through **Key 16**.
6. In the **Type** field, select **Flash**.
7. Click **Save Settings**.

## Sprecode Key

You can set a key to automatically activate specific services offered by the server by setting a key to **Sprecode**. For example, if the sprecode value of \*82 is configured, then by pressing the key, \*82 automatically activates a service provided by the server. The value you enter for this field is dependent on the services provided by the server. Contact your System Administrator for information about available services.

### Configuring a Sprecode Key Using the Aastra Web UI



#### Aastra Web UI

1. Click on **Operation > Softkeys and XML**.  
or  
Click on **Operation > Expansion Module <N>**.

**Softkeys Configuration**

Bottom Keys | Top Keys

Key	Type	Label	Value	Line
1	Sprecode	Sprecode	*82	1
2	None			1
3	None			1
4	None			1
5	None			1

#### Softkeys

2. Select from **Key 1** through **Key 20** on the Top keys.  
or  
Select from **Key 1** through **Key 18** on the Bottom keys.
3. In the **Type** field, select **Sprecode**.
4. In the **Label** field, enter a label to display on the IP phone for this key.
5. In the **Value** field, enter the appropriate value for accessing specific services from the server.  
**Note:**  
For values to enter in this field, contact your System Administrator.
6. In the state fields, check (enable) or uncheck (disable) the **Connected** state for this softkey.

#### Expansion Module Keys

7. Select from **Key 1** through **Key 16**.
8. In the **Type** field, select **Sprecode**.
9. In the **Value** field, enter the appropriate value for accessing specific services from the server.  
**Note:**  
For values to enter in this field, contact your System Administrator.
10. Click **Save Settings**.

## Park/Pickup Keys

The 6867i phone has a park and pickup call feature that allows you to park a call and pickup a call when required. The IP phones support the Park/Pickup feature on the Asterisk, BroadWorks, Sylanro, and ININ call managers.

The park/pickup feature performs as follows:

- When a call comes in and you pickup the handset, you can press the applicable **Park** key to park the call
- After the call is parked, you can press the **Pickup** key, followed by the applicable value to pickup the call

Administrators can configure the **Park** and **Pickup** keys for any line using the configuration files or the Aastra Web UI.

Users can make changes to customize the label of the **Park** and **Pickup** keys using the Web UI.

### Configuring Park/Pickup Keys Using the Aastra Web UI

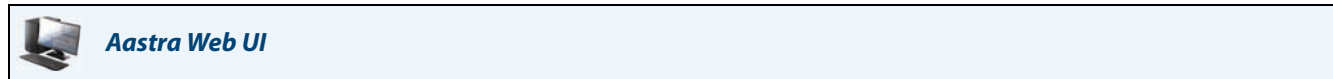

1. Click on **Operation > Softkeys and XML.**  
or  
Click on **Operation > Expansion Module <N>.**

**Softkeys Configuration**

Bottom Keys | Top Keys

Key	Type	Label	Value	Line
1	Park	Park	*88	1
2	Pickup	Pickup	*88	1
3	None			1
4	None			1
5	None			1

#### Softkeys

2. Select from **Key 1** through **Key 20** on the Top keys.  
or  
Select from **Key 1** through **Key 18** on the Bottom keys.
3. In the **Type** field, select **Park**.
4. In the **Label** field, enter a label for the **Park** softkey.  
**Note:**  
The **Value** and **Line** fields are configured by the Administrator.
5. In the state fields, check (enable) or uncheck (disable) the **Connected** state for this softkey.
6. Select from **Key 1** through **Key 20**.
7. In the **Type** field, select **Pickup**
8. In the **Label** field, enter a label for the **Pickup** softkey.  
**Note:**  
The **Value** and **Line** fields are configured by the Administrator.
9. In the state fields, check (enable) or uncheck (disable) the states you want to apply to this softkey.
10. Click **Save Settings**.
11. Click on **Reset**, then click **Restart** to restart the IP phone and apply the changes.

#### Expansion Module Keys

12. Select from **Key 1** through **Key 16**.

13. In the **Type** field, select **Park**.
14. In the **Value** field, enter the appropriate value for accessing specific services from the server.  
**Note:**  
The **Value** and **Line** fields are configured by the Administrator.
15. Select from **Key 1** through **Key 16**.
16. In the **Type** field, select **Pickup**.
17. In the **Value** field, enter the appropriate value for accessing specific services from the server.  
**Note:**  
The **Value** and **Line** fields are configured by the Administrator.
18. Click **Save Settings**.
19. Click on **Reset**, then click **Restart** to restart the IP phone and apply the changes.

### *Utilizing the Park Call/Pickup Parked Call Feature Using the IP Phone UI*

Use the following procedure on the IP phone to park a call and pick up a parked call.

#### *Parking a Call*

1. While on a live call, press the **Park** key.
2. Perform the following for your specific server:

##### **Asterisk**

Server announces the extension number where the call has been parked. Once the call is parked, press the  key to complete parking.

##### **BroadWorks**

After you hear the greeting from the CallPark server, enter the extension where you want to park the call.

##### **Sylantro**

Enter the extension number where you want to park the call, followed by # key.

##### **ININ**

Enter the extension number where you want to park the call, followed by # key.

If the call is parked successfully, the response is either a greeting voice confirming that the call was parked, or a hang up occurs. The parked call party hears music on hold.

3. If the call fails, you can pick up the call (using the next procedure) and press the **Park** key again to retry Step 2.

#### *Picking Up a Parked Call*

1. Pick up the handset on the phone.
2. Enter the extension number where the call was parked.
3. Press the **Pickup** key.  
If the call pick up is successful, you are connected with the parked call.

## Last Call Return Key

Using the Aastra Web UI, you can configure the Last Call Return function on a key. If you configure Last Call Return on a key, and a call comes into your phone, after you are finished with the call and hang up, you can press the key configured for Last Call Return and the phone dials the last call you received. When you configure an **Last Call Return** key, the label **LCR** displays next to that key on the IP phone. When the Sylantro call manager detects an Last Call Return request, it translates this request and routes the call to the last caller.

### Configuring a Last Call Return Key Using the Aastra Web UI



1. Click on **Operation > Softkeys and XML.**  
or  
Click on **Operation > Expansion Module <N>.**

#### Softkeys Configuration

Bottom Keys		Top Keys		
Key	Type	Label	Value	Line
1	Last Call Return			1
2	None			1
3	None			1
4	None			1
5	None			1

#### Softkeys

2. Select from **Key 1** through **Key 20** on the Top keys.  
or  
Select from **Key 1** through **Key 18** on the Bottom keys.
3. In the **Type** field, select **Last Call Return**.
4. In the **Line** field, select the line you want to apply to this key.  
Valid values are **1** through **9**.
5. In the state fields, check (enable) or uncheck (disable) the states you want to apply to this softkey.

#### Expansion Module Keys

6. Select from **Key 1** through **Key 16**.
7. In the **Type** field, select **Last Call Return**.
8. In the **Line** field, select the line you want to apply to this key.  
Valid values are **1** through **9**.
9. Click **Save Settings**.

## Call Forward Key

Using the Aastra Web UI, you can configure the Call Forward function on a softkey, programmable key, or expansion module key. Use call forwarding when you want a specific account on your phone to be forwarded to another number when your phone is in the busy state or the no answer state, or both. Pressing the **Call Fwd** softkey on the phone accesses the Call Forward menus. The menu that displays is dependant on the Call Forward mode (**Account** (default), **Phone**, or **Custom**) configured for the phone.

For more information about call forwarding and call forwarding modes, see “[Call Forward Configuration](#)” on page 141.

### Configuring a Call Forward Key Using the Aastra Web UI



#### Aastra Web UI

1. Click on **Operation > Softkeys and XML**.  
or  
Click on **Operation > Expansion Module <N>**.

#### Softkeys Configuration

Bottom Keys		Top Keys			
Key	Type	Label	Value	Line	
1	Call Fwd			1	
2	None			1	
3	None			1	
4	None			1	
5	None			1	

#### Softkeys

2. Select from **Key 1** through **Key 20** on the Top keys.  
or  
Select from **Key 1** through **Key 18** on the Bottom keys.
3. In the **Type** field, select **Call Fwd**.
4. In the state fields, check (enable) or uncheck (disable) the states you want to apply to this softkey.

#### Expansion Module Keys

5. Select from **Key 1** through **Key 16**.
6. In the **Type** field, select **Call Fwd**.
7. Click **Save Settings**.

### BLF/Xfer

**Note:**

BLF/Xfer functionality can only be programmed on the left softkeys.

The **BLF** key allows one or more extensions to be monitored, and once there is any state change with those extensions, the key shows the status of the monitored lines. The **Transfer** key allows a call to be transferred to other recipients blindly or consultatively. The **BLF/Xfer** key combines the **BLF** and **Transfer** keys' functionality together allowing the user to transfer calls or use BLF with one key.

**Note:**

It is recommended that you enable the **Switch UI Focus to Ringing Line** parameter when using the BLF/Xfer feature. For more information about this parameter, see [“Switch UI Focus to Ringing Line”](#) on page 152.

#### **BLF/Xfer Key Requirements and Functionality**

- **BLF/Xfer and BLF:** A **BLF/Xfer** key can be configured for subscribing to an extension and monitor the status of the extension, similar to the **BLF** key functionality. Changes of the state of the monitored extension are indicated by the key's graphical button image as well as the key's LED.
- **BLF/Xfer and Blind Transfer Calls:** When the focused line is in the connected state, pressing the **BLF/Xfer** key transfers the call to the extension unconditionally, disregarding the status of the monitored extension.  
If transferring a call to an extension fails, a message **Transfer Failed** displays on the phone, and you can reconnect the call (get the call back) by pressing the line key again.
- **BLF/Xfer and Call Forward:** When the focused line is in the ringing state, pressing the **BLF/Xfer** key forwards the call to the extension unconditionally, disregarding the status of the monitored extension.
- **BLF/Xfer and Speed Dial:** When the focused line and the monitored extension are idle, pressing the **BLF/Xfer** key causes the phone to go offhook and dial the number of the extension.



## Configuring a BLF/Xfer Key Using the Aastra Web UI



### Aastra Web UI

1. Click on **Operation > Softkeys and XML.**  
or  
Click on **Operation > Expansion Module <N>.**

#### Softkeys Configuration

Bottom Keys		Top Keys		
Key	Type	Label	Value	Line
1	BLF/Xfer	John	3500	1
2	None			1
3	None			1
4	None			1
5	None			1

#### Softkeys

2. Select from **Key 1** through **Key 20** on the Top keys.
3. In the **Type** field, select **BLF/Xfer**.
4. In the **Value** field, enter the monitored extension or the extension to transfer calls to (for example, 3500).
5. In the **Line** field, select the line for which you want to use the key functionality.  
Valid values are:
  - global
  - 1 through 9

#### Expansion Module Keys

6. Select from **Key 1** through **Key 16**.
7. In the **Type** field, select **BLF/Xfer**.
8. In the **Value** field, enter the monitored extension or the extension to transfer calls to (for example, 3500).
9. In the **Line** field, select the line for which you want to use the key functionality.  
Valid values are:
  - global
  - 1 through 9
10. Click **Save Settings**.

## Speed Dial/Xfer

The **Speed Dial** key allows a number to be dialed quickly by pressing one key configured for speed dialing. The **Transfer** key allows a call to be transferred to other recipients blindly or consultatively. The **Speed Dial/Xfer** key combines the **Speed Dial** and **Transfer** keys' functionality together allowing the user to transfer calls or speed dial with one key.

**Note:**

It is recommended that you enable the **Switch UI Focus to Ringing Line** parameter when using the Speed Dial/Xfer feature. For more information about this parameter, see "Switch UI Focus to Ringing Line" on page 152.

### Speed Dial/Xfer Key Requirements and Functionality

The **Speed Dial/Xfer** key has the following capabilities:

- Speed Dial/Xfer and Speed Dial: When the phone is in the idle state, pressing the **Speed Dial/Xfer** key causes the phone to go offhook and dial the predefined extension.
- Speed Dial/Xfer and Blind Transfer: When the phone is connected to a call, pressing the **Speed Dial/Xfer** key blind transfers the call to the predefined target.

If transferring a call fails, a message **Transfer Failed** displays, and you can reconnect the call (get the call back) by pressing the line key again.

- Speed Dial/Xfer and Call Forward: When the phone is in the ringing state, pressing the **Speed Dial/Xfer** key forwards the call to the predefined extension.

### Configuring a Speed Dial/Xfer Key Using the Aastra Web UI

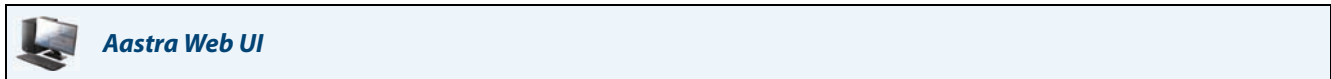

1. Click on **Operation > Softkeys and XML**.  
or  
Click on **Operation > Expansion Module <N>**.

**Softkeys Configuration**

Bottom Keys | Top Keys

Key	Type	Label	Value	Line
1	Speeddial/Xfer	Jane	3600	1
2	None			1
3	None			1
4	None			1
5	None			1

### Softkeys

2. Select from **Key 1** through **Key 20** on the Top keys.  
or  
Select from **Key 1** through **Key 18** on the Bottom keys.
3. In the **Type** field, select **Speed Dial/Xfer**.
4. In the **Label** field, enter a label for the Speed Dial/Xfer key.
5. In the **Value** field, enter the speed dial extension or the extension to transfer calls to (for example, 3600).
6. In the **Line** field, select the line for which you want to use the key functionality.  
Valid values are:
  - global
  - 1 through 9

7. In the state fields, check (enable) or uncheck (disable) the states you want to apply to this softkey.

**Expansion Module Keys**

8. Select from **Key 1** through **Key 16**.

9. In the **Type** field, select **Speed Dial/Xfer**.

10. In the **Value** field, enter the speed dial extension or the extension to transfer calls to (for example, 3600).

11. In the **Line** field, select the line for which you want to use the key functionality.

Valid values are:

- global
- 1 through 9

12. Click **Save Settings**.

## Speed Dial/Conf

The 6867i allows you to configure a softkey or programmable key or expansion module key to be used as a speed dial conference key (**Speed Dial/Conf** key) while remaining in the current call. This key allows a user on a call to conference another party at a pre-defined number while remaining in the call.

For example, while on an active call, a user can use the **Speed Dial/Conf** key to dial a recording service and have the resulting conference recorded.

**Note:**

If currently in a conference, the **Speed Dial/Conf** key is disabled on the active call.

If you configure a softkey or programmable key or expansion module key as a **Speed Dial/Conf** key and you press this key while on an active call, the focused line changes to the dialing line. A **Cancel** softkey displays on the phone allowing you to abort the conference speed dial if required.

**Note:**

This feature is not compatible with centralized conferencing.

### Configuring a Speed Dial/Conf Key Using the Aastra Web UI



1. Click on **Operation > Softkeys and XML.**  
or  
Click on **Operation > Expansion Module <N>.**

**Softkeys Configuration**

Bottom Keys | Top Keys

Key	Type	Label	Value	Line
1	Speeddial/Conf	Jane	3600	1
2	None			1
3	None			1
4	None			1
5	None			1

**Softkeys**

2. Select from **Key 1** through **Key 20** on the Top keys.  
or  
Select from **Key 1** through **Key 18** on the Bottom keys.
3. In the **Type** field, select **Speed Dial/Conf**.
4. In the **Label** field, enter a label for the Speed Dial/Conf key.
5. In the **Value** field, enter the speed dial extension or the extension to add to the conference (for example, 3600).
6. In the **Line** field, select the line for which you want to use the key functionality.  
Valid values are:
  - global
  - 1 through 9
7. In the state fields, check (enable) or uncheck (disable) the states you want to apply to this softkey.

**Expansion Module Keys**

- 8.** Select from **Key 1** through **Key 16**.
- 9.** In the **Type** field, select **Speed Dial/Conf**.
- 10.** In the **Value** field, enter the speed dial extension or the extension to add to the conference (for example, **3600**).
- 11.** In the **Line** field, select the line for which you want to use the key functionality.  
Valid values are:
  - global
  - **1** through **9**
- 12.** Click **Save Settings**.

## Directory Key

By default, the 6867i has a dedicated **Directory** key. However, using the Aastra Web UI, you can assign the **Directory** key to any key on the left or bottom softkeys on the phone.

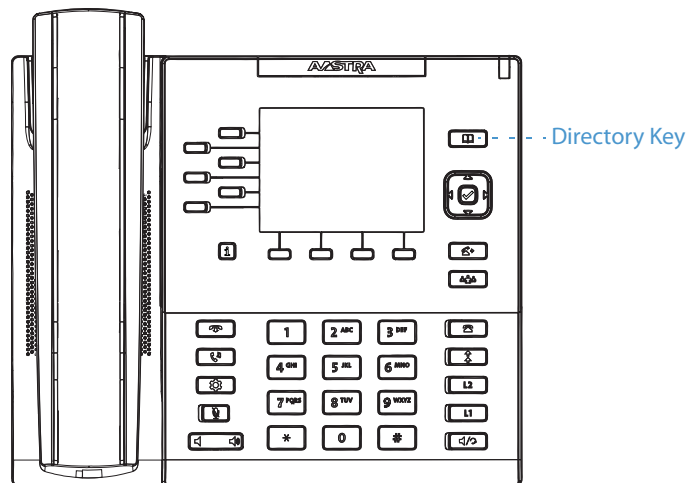

The Directory feature allows you to store frequently used names and numbers on the phone. You can also dial directly from a Directory entry. You can use the **Directory** key to access a Directory which contains a customized list of names with phone numbers and labels.

In addition to creating a **Directory** key, you can also download a Directory to your PC, if required, using the Aastra Web UI.

**Note:**

For more information about the Directory, see ["Directory"](#) on page 122.

## Configuring a Directory Key Using the Aastra Web UI



### Aastra Web UI

1. Click on **Operation > Softkeys and XML.**  
or  
Click on **Operation > Expansion Module <N>.**

#### Softkeys Configuration

Bottom Keys		Top Keys		
Key	Type	Label	Value	Line
1	Directory			1
2	None			1
3	None			1
4	None			1
5	None			1

#### Softkeys

2. Select from **Key 1** through **Key 20** on the Top keys.  
or  
Select from **Key 1** through **Key 18** on the Bottom keys.
3. In the **Type** field, select **Directory**.
4. In the **Label** field, enter a label to apply to this key.
5. In the state fields, check (enable) or uncheck (disable) the states you want to apply to this softkey.

#### Expansion Module Keys

6. Select from **Key 1** through **Key 16**.
7. In the **Type** field, select **Directory**.
8. Click **Save Settings**.

## Callers List Key

By default, the 6867i has a dedicated **Callers List** key. However, using the Aastra Web UI, you can assign the **Callers List** key to any key on the left or bottom keys on the phone.

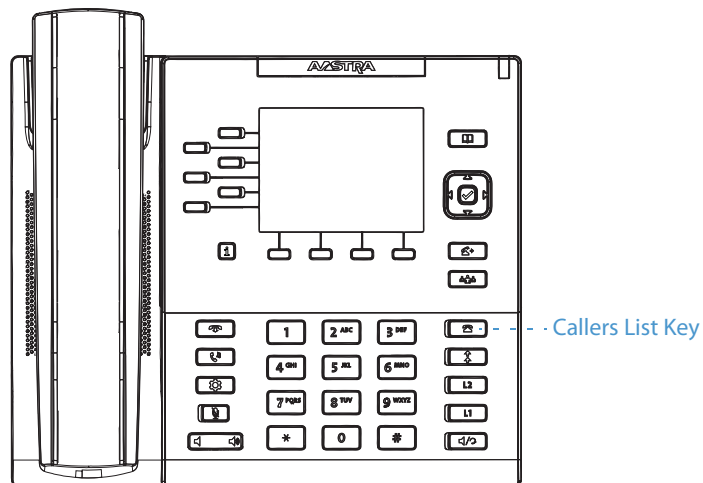

The Callers List is a stored log of your incoming calls. You can use the **Callers List** key to access a list of callers that called your phone.

**Note:**

For more information about the Callers List, see ["Callers List"](#) on page 130.



## Configuring a Callers List Key Using the Aastra Web UI



### Aastra Web UI

1. Click on **Operation > Softkeys and XML.**  
or  
Click on **Operation > Expansion Module <N>.**

#### Softkeys Configuration

Bottom Keys		Top Keys		
Key	Type	Label	Value	Line
1	Callers List	Callers		1
2	None			1
3	None			1
4	None			1
5	None			1

#### Softkeys

2. Select from **Key 1** through **Key 20** on the Top keys.  
or  
Select from **Key 1** through **Key 18** on the Bottom keys.
3. In the **Type** field, select **Callers List**.
4. In the **Label** field, enter a label to apply to this key.
5. In the state fields, check (enable) or uncheck (disable) the states you want to apply to this softkey.

#### Expansion Module Keys

6. Select from **Key 1** through **Key 16**.
7. In the **Type** field, select **Callers List**.
8. Click **Save Settings**.

## Redial Key

By default, the 6867i has a dedicated **Redial** key. However, using the Aastra Web UI, you can assign the **Redial** key to any key on the left or bottom keys on the phone.

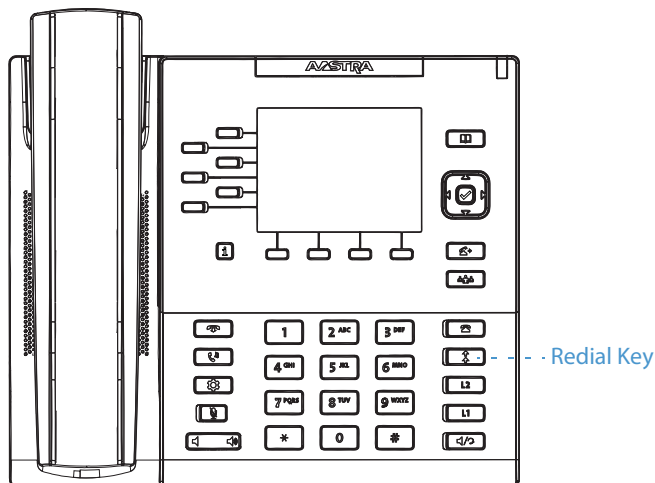

The Redial List is a stored log of your outgoing calls. You can use the **Redial** key to access a list of the most recent calls you placed.

**Note:**

For more information about the Redial List, see “Redial” on page 105.

## Configuring a Redial Key Using the Aastra Web UI



### Aastra Web UI

1. Click on **Operation > Softkeys and XML.**  
or  
Click on **Operation > Expansion Module <N>.**

#### Softkeys Configuration

Bottom Keys		Top Keys		
Key	Type	Label	Value	Line
1	Redial	Redial		1
2	None			1
3	None			1
4	None			1
5	None			1

#### Softkeys

2. Select from **Key 1** through **Key 20** on the Top keys.  
or  
Select from **Key 1** through **Key 18** on the Bottom keys.
3. In the **Type** field, select **Redial**.
4. In the **Label** field, enter a label to apply to this key.
5. In the state fields, check (enable) or uncheck (disable) the states you want to apply to this softkey.

#### Expansion Module Keys

6. Select from **Key 1** through **Key 16**.
7. In the **Type** field, select **Redial**.
8. Click **Save Settings**.

## Conference Key

By default, the 6867i has a dedicated **Conference** key. However, using the Aastra Web UI, you can assign the **Conference** key to any key on the left or bottom keys on the phone.

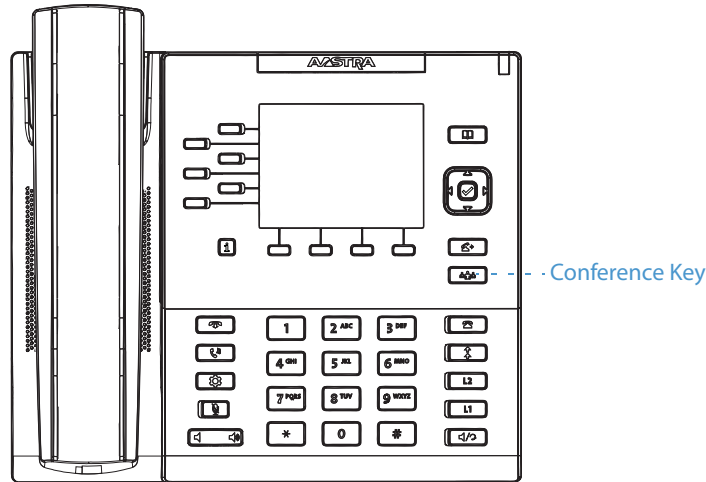

**Note:**

For more information about conferencing, see “Conferencing Calls” on page 116.

### Configuring a Conference Key Using the Aastra Web UI



1. Click on **Operation > Softkeys and XML**.  
or  
Click on **Operation > Expansion Module <N>**.

**Softkeys Configuration**

Bottom Keys		Top Keys		
Key	Type	Label	Value	Line
1	Conference	Conf		1
2	None			1
3	None			1
4	None			1
5	None			1

**Softkeys**

2. Select from **Key 1** through **Key 20** on the Top keys.  
or  
Select from **Key 1** through **Key 18** on the Bottom keys.
3. In the **Type** field, select **Conference**.
4. In the **Label** field, enter a label to apply to this key.
5. In the state fields, check (enable) or uncheck (disable) the states you want to apply to this softkey.

**Expansion Module Keys**

6. Select from **Key 1** through **Key 16**.
7. In the **Type** field, select **Conference**.
8. Click **Save Settings**.

## Transfer Key

By default, the 6867i has a dedicated **Transfer** key. However, using the Aastra Web UI, you can assign the **Transfer** key to any key on the left or bottom keys on the phone.

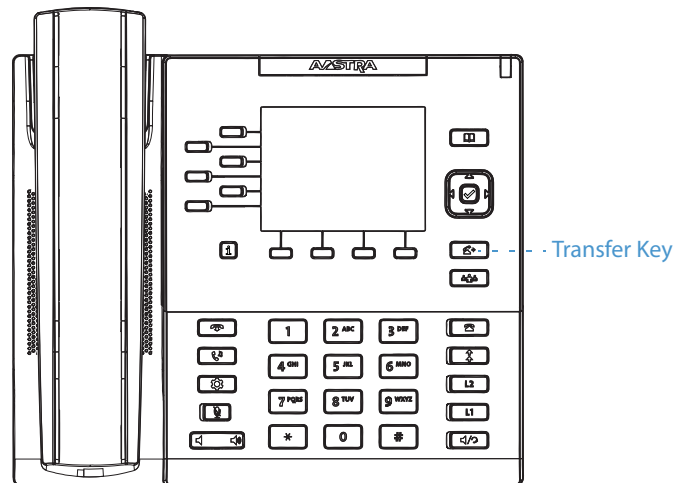

### Note:

For more information about transferring calls, see “Transferring Calls” on page 111.

### Configuring a Transfer Key Using the Aastra Web UI



#### Aastra Web UI

1. Click on **Operation > Softkeys and XML**.  
or  
Click on **Operation > Expansion Module <N>**.

#### Softkeys Configuration

Bottom Keys		Top Keys		
Key	Type	Label	Value	Line
1	Transfer	Xfer		1
2	None			1
3	None			1
4	None			1
5	None			1

#### Softkeys

2. Select from **Key 1** through **Key 20** on the Top keys.  
or  
Select from **Key 1** through **Key 18** on the Bottom keys.
3. In the **Type** field, select **Transfer**.
4. In the **Label** field, enter a label to apply to this key.
5. In the state fields, check (enable) or uncheck (disable) the states you want to apply to this softkey.

#### Expansion Module Keys

6. Select from **Key 1** through **Key 16**.
7. In the **Type** field, select **Transfer**.
8. Click **Save Settings**.

## Intercom Key

You can use the **Intercom** key to automatically connect with a remote extension for outgoing calls, and to answer an incoming intercom call.

**Note:**

For more information about the Intercom feature, see “Using Intercom Functionality” on page 104.

### Configuring an Intercom Key Using the Aastra Web Ui

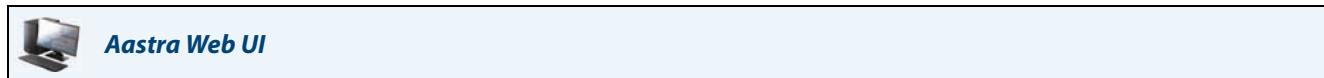

1. Click on **Operation > Softkeys and XML.**  
or  
Click on **Operation > Expansion Module <N>.**

**Softkeys Configuration**

Bottom Keys		Top Keys			
Key	Type	Label	Value	Line	
1	Icom	Icom		1	
2	None			1	
3	None			1	
4	None			1	
5	None			1	

**Softkeys**

2. Select from **Key 1** through **Key 20** on the Top keys.  
or  
Select from **Key 1** through **Key 18** on the Bottom keys.
3. In the **Type** field, select **Icom**.
4. In the **Label** field, enter a label to apply to this key.
5. In the state fields, check (enable) or uncheck (disable) the states you want to apply to this softkey.

**Expansion Module Keys**

6. Select from **Key 1** through **Key 16**.
7. In the **Type** field, select **Icom**.
8. Click **Save Settings**.

## Phone Lock Key

You can configure a key on the IP phone to use as a lock/unlock key. You assign the function of the key as **Phone Lock**.

### Configuring a Phone Lock Key



Aastra Web UI

1. Click on **Operation > Softkeys and XML**.  
or  
Click on **Operation > Expansion Module <N>**.

#### Softkeys Configuration

Bottom Keys		Top Keys			
Key	Type	Label	Value	Line	
1	Phone Lock			1	
2	None			1	
3	None			1	
4	None			1	
5	None			1	

#### Softkeys

2. Select from **Key 1** through **Key 20** on the Top keys.  
or  
Select from **Key 1** through **Key 18** on the Bottom keys.
3. In the **Type** field, select **Phone Lock** from the list of options.

#### Expansion Module Keys

4. Select from Key 1 through Key 16.
5. In the **Type** field, select **Phone Lock** from the list of options.
6. Click **Save Settings**.

#### Note:

You can lock/unlock the phone using the new key you just configured, using the Aastra Web UI at the path *Operation > Phone Lock*, or using the **Phone Lock** option on the IP phone UI at the path *Options > Lock > Phone Lock*. For more information about using the lock/unlock feature, see "Locking the Phone Using the IP Phone UI" on page 41.

## Paging Key

You can configure a **Paging** key on the phone that allows you to send a Real Time Transport Protocol (RTP) stream to pre-configured multicast address(es) without involving SIP signalling. You enter a multicast IP address(es) and a port number for the Paging key, that when pressed, initiates an outgoing multicast RTP session. This is called Group Paging on the IP phones.

You can also specify group paging RTP addresses that the phone listens for when receiving RTP streams. You can specify up to 5 listening multicast addresses at the path, *Basic Settings > Preferences > Group Paging RTP Settings*.

For more information about Group Paging and how it works, and to specify multicast addresses, see “[Group RTP Paging](#)” on [page 160](#).

### Configuring a Paging Key Using the Aastra Web UI

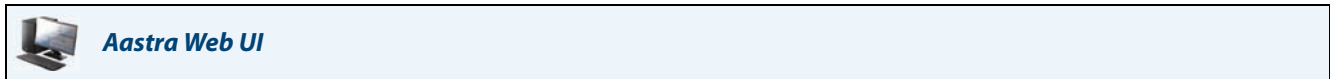

1. Click on **Operation > Softkeys and XML**.  
or  
Click on **Operation > Expansion Module <N>**.

**Softkeys Configuration**

Bottom Keys | Top Keys

Key	Type	Label	Value	Line
1	Paging	Group 1	239.0.1.15:10000	1
2	None			1
3	None			1
4	None			1
5	None			1

#### Softkeys

2. Select from **Key 1** through **Key 20** on the Top keys.  
or  
Select from **Key 1** through **Key 18** on the Bottom keys.
3. In the **Type** field, select **Paging**.
4. In the **Label** field, enter a label to apply to this key.
5. In the **Value** field, enter a multicast IP address and a port number for the **Paging** key. When you press this key, the phone initiates an outgoing multicast RTP session to the specified address using the specified port (e.g. 239.0.1.15:10000).

**Notes:**

1. When you select **Paging** for the **Type** field, the **Line** field is disabled.
  2. The **Value** field allows for one multicast address entry only.
6. To receive RTP streams for group paging, you must also configure the **Paging Listen Addresses** parameter at the path, *Basic Settings > Preferences > Group Paging RTP Settings*. For more information about setting this parameter, see “[Group RTP Paging](#)” on [page 160](#).

#### Expansion Module Keys

7. Select from Key **1** through Key **16**.
8. In the **Type** field, select **Paging**.



9. In the **Value** field, enter a multicast IP address and a port number for the Paging key. When you press this key, the phone initiates an outgoing multicast RTP session to the specified address using the specified port. (For example, 239.0.1.15:10000).

**Notes:**

1. When you select **Paging** for the **Type** field, the **Line** field is disabled.
2. The **Value** field allows for one multicast address entry only.

10. To receive RTP streams for group paging, you must also configure the **Paging Listen Addresses** parameter at the path, *Basic Settings > Preferences > Group Paging RTP Settings*. For more information about setting this parameter, see “[Group RTP Paging](#)” on page 160.

11. Click **Save Settings** to save your changes

### Using the Paging Key

The following procedure describes the use of the **Paging** key on the IP phone. The procedure assumes you have already configured the **Paging** key using the Aastra Web UI.

**Notes:**

- The recipient of a paging call can set a global DND to ignore any incoming pages.
- For incoming paging, the phone uses the Intercom configuration settings. The incoming page is dependant on the **Allow Barge In** parameter setting and the idling/on call state.



#### IP Phone UI

1. On the IP phone, press the softkey or expansion module key you configured for **Paging**.  
The phone opens a multicast RTP session and an outgoing OR incoming phone screen displays.
2. Press the **Drop** key to end the multicast RTP session and return to the **Home** screen.

**Note:**

If you enable global DND on the phone, the incoming multicast RTP session is dropped.

## Empty Key

You can set a softkey to force a blank entry on the IP phone display for a specific key. You do this by setting the softkey to **Empty**. The keys are added in order (from key 1 to key 20) after any hard-coded keys have been added. If a particular key is not defined, it is ignored.

### Configuring an Empty Key Using the Aastra Web UI



1. Click on **Operation > Softkeys and XML**.  
or  
Click on **Operation > Expansion Module <N>**.

**Softkeys Configuration**

Bottom Keys | **Top Keys**

Key	Type	Label	Value	Line
1	Empty			1
2	Empty			1
3	Empty			1
4	Empty			1
5	Empty			1

#### Softkeys

2. Select from **Key 1** through **Key 20** on the Top keys.  
or  
Select from **Key 1** through **Key 18** on the Bottom keys.
3. In the **Type** field, select **Empty**.
4. In the state fields, check (enable) or uncheck (disable) the states you want to apply to this softkey.

#### Expansion Module Keys

5. Select from Key 1 through Key 16.
6. In the **Type** field, select **Empty**.
7. Click **Save Settings**.

## None Key

Use the following procedure to delete a key's functionality on the 6867i IP phone.

### Deleting a Key's Function Using the Aastra Web UI



#### Aastra Web UI

1. Click on **Operation > Softkeys and XML.**  
or  
Click on **Operation > Expansion Module <N>.**

#### Softkeys Configuration

Bottom Keys		Top Keys			
Key	Type	Label	Value	Line	
1	None			1	
2	None			1	
3	None			1	
4	None			1	
5	None			3	

2. Choose the key you want to delete from the phone or expansion module.
3. In the **Type** field, select **None**.
4. Click **Save Settings**.  
The key function is deleted from the IP phone memory.

# Making Calls

This section describes ways to make calls on your 6867i phone, using your handset, speakerphone or headset.

## Dialing a Number

First, take the phone off-hook by:

- Lifting the handset
- Pressing  or
- Pressing a line/call appearance button

At the dial tone, enter the number you wish to call.

### Note:

After dialing the number, the phone has a short delay before sending the call. To send the call immediately, you can press the **Dial** softkey (if the handset is offhook) or the # key immediately after dialing the number. The phone sends the call without delay.

If you are unable to make calls within certain area codes, check with your System Administrator for any toll restrictions placed on your extension that may restrict your access to long distance area codes or dialing prefixes.

When your party picks up, a timer appears on your display that records the length of your call.

If the **Live Dialpad** option is on, as soon as you press the first digit on the dialpad the phone automatically selects the next available line, goes off-hook, and dials as digits are pressed.

## Pre-Dialing a Number

You can also make a call by pre-dialing a number. Pre-dialing lets you view a number before you dial.







With the phone in an idle state and on-hook, simply use the dialpad to enter the number you wish to call, and after reviewing the number, press the **Dial** softkey. Use the **Backspace** softkey to correct any errors and the **Pause** softkey to insert pauses.

## Using Handsfree Speakerphone

The handsfree feature allows you to speak to someone without using the handset or headset. Your phone must be in either the **Speaker** or **Speaker/Headset** audio mode. For more information about setting the audio mode on your phone, see “Audio Mode” on page 45.



### IP Phone UI

- To dial using handsfree, first press  and enter a number at the dial tone.
- To answer a call on your phone using handsfree, press  or the line/call appearance button.
- If you are in **Speaker** audio mode, lift the handset and press  to switch between handsfree and handset.
- If you are in **Speaker/Headset** audio mode, press  to switch between handsfree and headset.
- When the handset is on hook, press  to disconnect the call.

#### Note:

When handsfree is on, the speaker light turns on.

## Using a Headset

The 6867i accepts headsets through the modular RJ22 jack on the back of the phone. Contact your telephone equipment retailer or distributor to purchase a compatible headset.

#### Important!

- The headset port is for headset use only. Plugging any other devices into this port may cause damage to the phone and will void your warranty.
- Customers should read and observe all safety recommendations contained in headset operating guides when using any headset.



### Volume Controls for the Headset Microphone

On the 6867i, there are three options for the headset microphone volume: **Low**, **Medium**, and **High**. For information about configuring the headset microphone volume, see “Headset” on page 46.

### Making and Receiving Calls Using a Headset



### IP Phone UI



1. Ensure that you have selected a headset audio mode (see “Configuring the Audio Mode Using the IP Phone UI” on page 45).
  2. Turn the phone over and locate the headset jack marked .
    - If you have a headset with an RJ9/RJ22 4-pin connector, insert the headset cord into the jack until it clicks into place.
    - If you have a DHSG/EHS headset with an RJ45 6-pin or 8-pin connector, remove the plastic headset jack adapter and then insert the cord into the jack until it clicks into place.
- Note:**  
See the **Aastra 6867i SIP IP Phone Installation Guide** for more information.
3. Press the  key to obtain a dial tone or to answer an incoming call. Depending on the audio mode selected from the Options List, a dial tone or an incoming call is received on either the headset or the handsfree speakerphone.
  4. Press the  key to end the call.

## Using Intercom Functionality

On the 6867 you can use the **Icom** key to automatically connect with a remote extension.

### Using the Icom Key



1. Press the **Icom** key.
2. Enter the extension number of the person you wish to intercom or the **BLF** key for that extension.
3. After a beep tone, your phone automatically connects with the remote extension and you can speak through its speaker.
4. To cancel intercom, press  or the **Cancel** key.
5. When you are finished speaking, hang up the phone by placing the handset back on-hook or by pressing  or the line/call appearance button for the active call. When you hang up, the remote phone also hangs up.

You can set specific incoming Intercom call features on the 6867i IP phone using the Aastra Web UI. The following table describes these features.

Incoming Intercom Features in Aastra Web UI	Description
Microphone Mute	Allows you to enable or disable the microphone on the IP phone for Intercom calls made by the originating caller.
Auto Answer	Allows you to enable or disable the IP phone to automatically answer an Intercom call. If auto-answer is enabled on the IP phone, the phone plays a tone (if Play Warning Tone is enabled) to alert the user before answering the intercom call. If auto-answer is disabled, the phone treats the incoming intercom call as a normal call.
Play Warning Tone	Allows you to enable or disable a warning tone to play when the phone receives an incoming intercom call on an active line.
Allow Barge In	Allows you to enable or disable how the phone handles incoming intercom calls while the phone is on an active call.

**Note:**

For more information about the incoming Intercom features and for procedures on setting these features, see [“Incoming Intercom Call Features”](#) on page 158.

## Redial



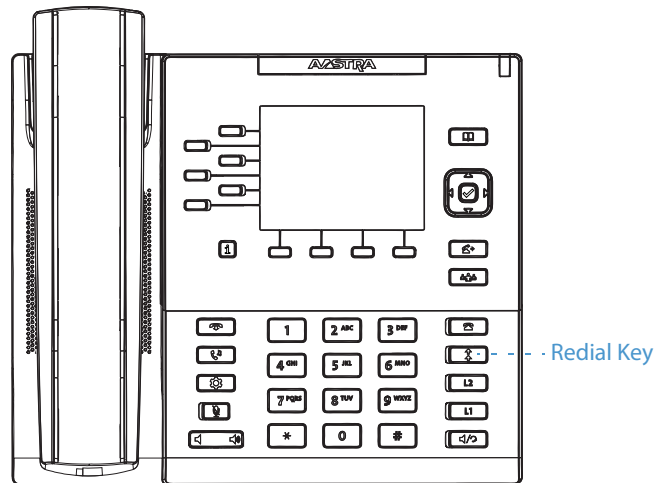

The Redial List stores information for up to the last 100 numbers you called. Your phone logs the name/number of the called party, when you called, and if the call was answered or missed. Additional information such as the duration of the call, line used, and call features utilized during the call can also be viewed.

You can view, scroll, and delete line items in the Redial List from the IP phone UI as well as copy selected entries to the Directory. You can also dial out directly using a displayed entry in the Redial List.

On the 6867i, you access the Redial List by the  key.



The following table identifies and describes the various icons displayed in the Redial List.

Icon	Description
	Indicates an outgoing call that was answered.
	Indicates an outgoing call that was not answered.
<b>Call Feature Indicators (in detailed view only)</b>	
	Indicates the call was secured using TLS/SRTP encryption.
	Indicates the call was using Aastra Hi-Q™ audio.
	Indicates active VoIP recording was enabled and the call was recorded.

### Notes:

- When the Redial List is full, the oldest call records are deleted to accommodate the information of new called parties.
- If the telephone number of an incoming or outgoing call matches a number that you have programmed with a name in a softkey or the Directory, the Redial List display the same name and number.
- For details on the total number of Redial List entries currently stored on your phone, see [“Phone Status via IP Phone UI”](#) on page 23.

Accessing the Redial List

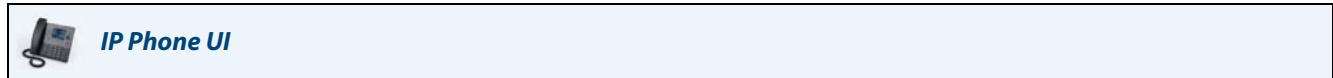

1. Press  once to access the **Redial List**.

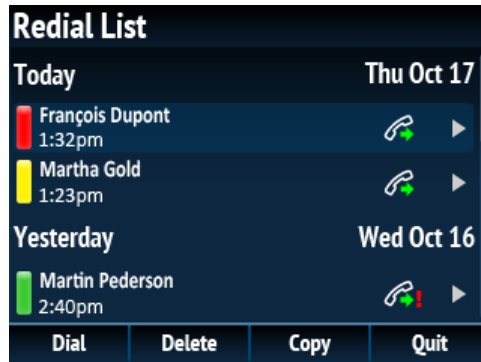

**Note:**



Press  twice to dial the most recent number you dialed from the phone.

2. Press  to see more detailed information about they redial entry.



**Note:**

The detailed view screen contains the picture ID of the called party (if available), the date and time of the outgoing call, whether or not the call was answered, the line on which the call was placed, call duration (if the call was answered), any applicable call feature indicators, and the caller ID details.

3. To dial the displayed number while in the Redial List, press the  button, press , press the **Dial** softkey, lift the handset, or press any of the line keys.

4. To exit the Redial List, press  or the **Quit** softkey.



### Deleting an Entry In the Redial List



#### IP Phone UI

1. Press  once to access the **Redial List**.
2. Use the ▲ and ▼ keys to scroll through the entries in the Redial List.
3. Press the **Delete** softkey.

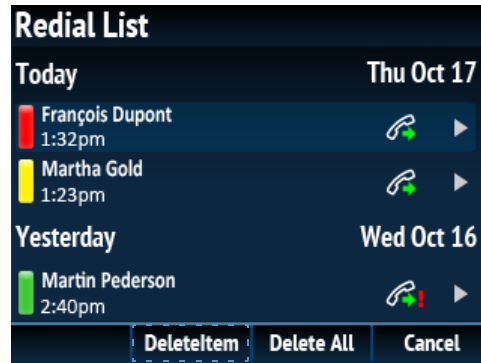

4. Press the **Delete Item** softkey to erase the entry.

### Deleting All Entries In the Redial List



#### IP Phone UI

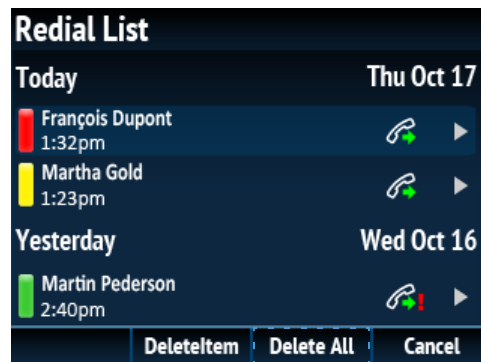

1. Press  once to access the **Redial List**.
2. Press the **Delete** softkey.



3. Press the **Delete All** key to erase all items.

## Copying Entries to the Directory



1. Press the  key.
2. Press the  and  navigation keys to scroll through and highlight the respective Redial List entry.

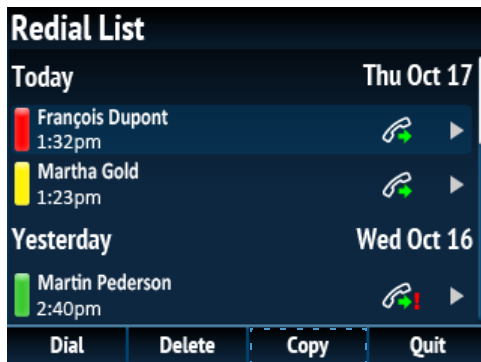





3. Press the **Copy** softkey.

The entry is copied to the Directory.

**Note:**

If the contact's name already exists in the Directory but the number is different, press the **Replace** softkey to replace the contact's old number with the new number or press the **Merge** softkey to add the new number as an additional number while keeping the old number intact.

## Mute

You can use the  key to mute the handset, headset, or speakerphone. When you use the  key on your phone, you cannot be heard on an active call or on a conference. For muted calls, the handsfree LED flashes and the  key LED is on. To switch mute on or off, press .

**Note:**

If you place a muted call on hold, the phone automatically takes the call off mute when you reconnect to the call.

# Receiving Calls



When a call is ringing at your extension, the inbound callers name, extension, picture ID (if applicable), and incoming call icon display on the screen. Additionally, the line/call appearance LED flashes quickly for the incoming call.



## Answering an Incoming Call



### IP Phone UI

- For handsfree operation, press , the **Answer** softkey, or the line/call appearance button for the incoming call.
- Press  for headset operation.
- Lift the handset for handset operation.

#### Note:

The audio mode setting you have selected in *Options List > Headset Settings* on the IP phone UI determines if the call goes to handsfree or headset operation. For more information, see the section “[Audio Mode](#)” on [page 45](#).



If the phone is already connected to a call, pressing the line/call appearance button or **Answer** softkey for the new incoming call automatically places the connected call on hold and answers the new call. To reconnect to a party, press the line/call appearance button for that call or navigate to the call on hold and press the **Pickup** softkey.

If you cannot answer the call, the caller goes to voicemail (if voicemail has been configured for your extension).

#### Note:

The  key can be used to cancel the call pickup procedure.

## Sending an Incoming Call to Voicemail

You can send an incoming call directly to voicemail without answering the call. To do this, press  without picking up the handset. If you are already on the phone your incoming call should go directly to voicemail. Your phone screen displays a voicemail icon  displaying the number of pending messages.

# Handling Calls

When you are connected to a call, you can use the softkeys or hard keys on the phone to place a call on hold, transfer a call, or create a conference call.

## Placing a Call on Hold

You can place an active call on hold by pressing the  key. When you place a call on hold, only your phone can retrieve the call.

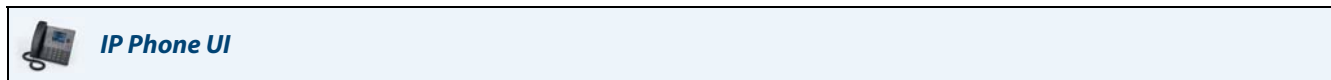

1. Connect to the call (if not already connected).
2. Press the  key.



The screen displays the  icon indicating the call is on hold. Additionally, the line/call appearance light begins to flash slowly and after a short time the phone beeps softly to remind you that you still have a call on hold.

**Note:**

If you are connected to another call, the phone does not beep to remind you that you still have a call on hold.

### When on Hold



To let your caller know that they are still on hold, music plays softly (if this has been set up for your system). The call/line appearance light for the line you are on remains solid to indicate that you are still connected.



### Automatic Hold

When juggling between calls, you do not have to press the  button to go from one call to the next. The phone automatically puts your current call on hold as soon as you press a new line/call appearance button.

### Retrieving a Held Call

If you have more than one call on hold, you can reconnect to a held call by pressing the line/call appearance button where that call is being held or by navigating to the call on the **Line Selection** or any **Call** screen and pressing  or **Pickup** softkey. Press  or the **Drop** softkey to disconnect the call.

## Transferring Calls

The 6867i IP phone has a dedicated **Transfer** key. You can use this hard key to transfer calls or use the **Xfer** softkey offered on screen when in a connected call.

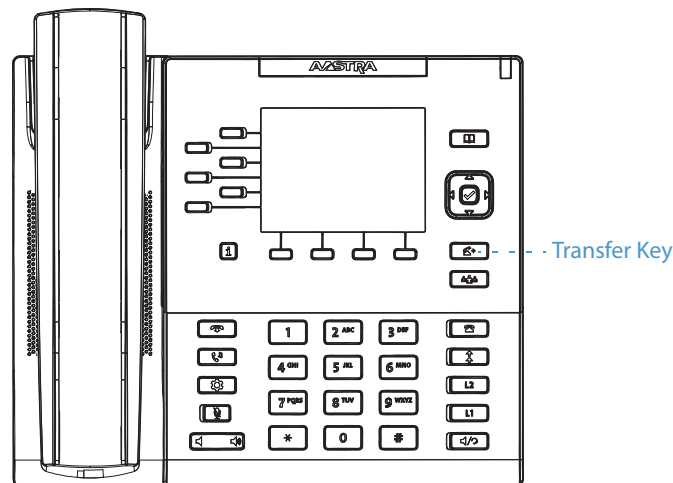

### Blind Transfer

A blind transfer is when you transfer a call directly to another extension without consulting with the person receiving the call. To do this, simply complete the transfer immediately after you have entered the number. The call goes directly to the extension or outside line you transferred to.

### Consultative Transfer

You also have the option to consult with the person you are transferring the call to, before you complete the transfer. To do this, simply remain on the line until the receiving party answers the call. After consulting with the receiving party, you can either complete the transfer or cancel the transfer to go back to the original call.

### Direct Transfer

The 6867i IP phone provides a convenient direct method of transferring an existing call to another existing call. If you have the transfer recipient on hold on another line, you can simply navigate to the recipient and press the  key or **Xfer** softkey and the direct transfer will be performed.

## Transferring Calls

Use the following procedure to transfer a call to another extension.

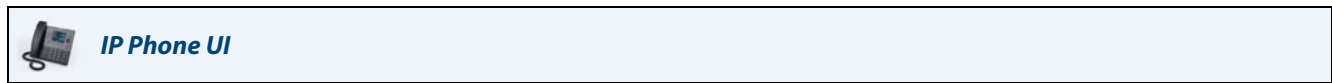

1. Connect to Party 1 (if not already connected). Party 1 is the party you want to transfer.



2. Press the key or **Xfer** softkey.



3. Enter the extension number (or the outside number) to Party 2.



To cancel the transfer you can either press the **Cancel** softkey on the display screen, press , or hang up the handset.

4. Complete either a blind or consultative transfer:
  - a) To complete a blind transfer, press the key or **Xfer** softkey key again before the receiving end answers.
  - b) To complete a consultative transfer, press **Dial** and remain on the line to speak with the Party 2, before either pressing the key, **Xfer** softkey, key, or hanging up the handset to transfer Party 1 to Party 2.

## Transferring an Existing Call to Another Existing Call



### IP Phone UI

1. Ensure you are on an active call with the party you wish to transfer (the transfer recipient should be placed on hold).

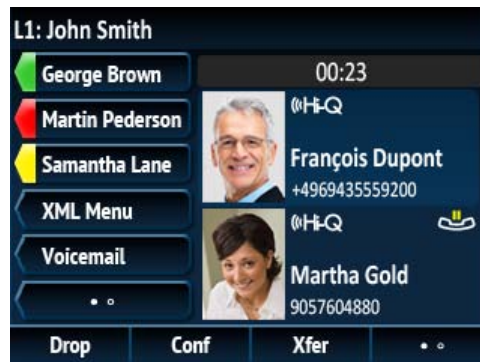

#### Note:

Direct transferring can be performed in either the **Mult-View Call** screen or **Detailed View Call** screen.

2. Press the ▲ or ▼ navigation keys to highlight the party to whom you wish to transfer the active call.

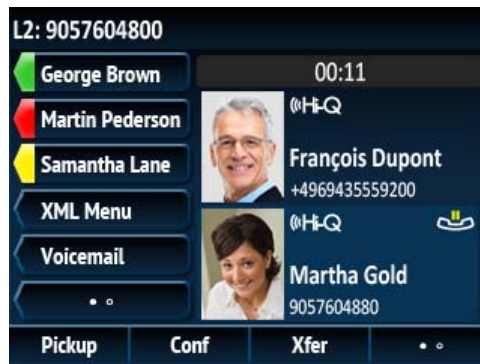

3. Press the  key or **Xfer** softkey. The active call will be transferred.

### Transferring to a Contact in the Directory

Users can complete a transfer to a contact in their local directory. If a user is in a call and initiates a transfer, they can navigate to the Directory screen and use the  key to complete a blind or consultative transfer.



1. Connect to Party 1 (if not already connected). Party 1 is the party you want to transfer.





2. Press the  key or **Xfer** softkey.

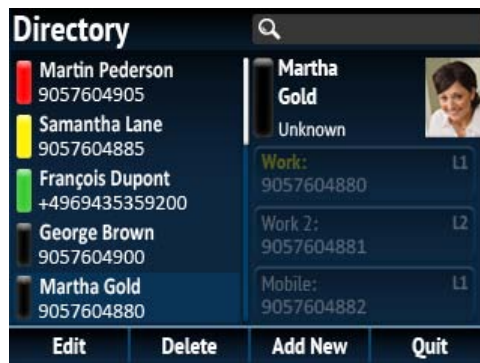

3. Press the  key and highlight a directory entry (and select the desired number if the entry contains more than one number).



4. Complete either a blind or consultative transfer:
  - a) To complete a blind transfer, press the  key before the receiving end answers.
  - b) To complete a consultative transfer, press the  button to call the contact. Remain on the line to speak with Party 2 before pressing the  key or **Xfer** softkey again to transfer Party 1 to Party 2.

To cancel the transfer, press the **Cancel** softkey on the display screen or press .



### Indication of Transferred Calls

When you transfer an active call, the near-end phone displays a **Call Transferred** screen when a call is transferred and the far-end call is dropped. The figure below illustrates the **Call Transferred** screen on the 6867i phone.



## Conferencing Calls

The 6867i IP phone has a dedicated **Conference** key. You can use this hard key to create conference calls or use the **Conf** softkey offered on screen when in a connected call.

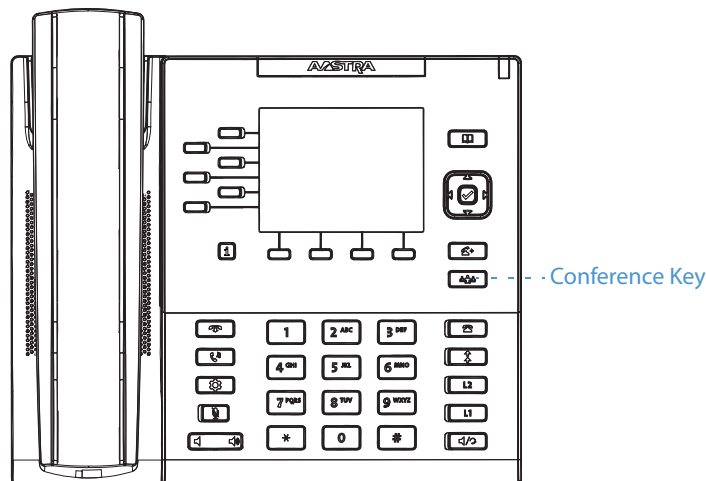

The 6867i IP phone offers two methods of conferencing:

- Local conferencing (default method).
- Centralized conferencing (for Sylantrio and BroadSoft call managers - Administrators must enable this method).

### Local Conferencing

The 6867i phone supports up to three parties (including yourself) in a conference call. This is called local conferencing and is the default method of conferencing on the 6867i.

#### Note:

Your System Administrator can set your **Conference** key to speed dial a specific number. Contact your System Administrator for more information.

### Creating a Conference Call Using Local Conferencing

Use the following procedure to create a conference call using local conferencing.



#### IP Phone UI

1. When you begin a conference, you are the first party in the conference (Party 1). Pickup the handset or press the  key. A line opens up.
2. Call Party 2 by dialing their number (or answer an incoming call of a party).

3. Wait for Party 2 to answer. When Party 2 answers, you can consult with them before adding them to the conference.



4. Press the  key or **Conf** softkey.



5. Enter the phone number of Party 3.



- Wait for Party 3 to answer. When Party 3 answers, you can consult with them before adding them to the conference.



- Press the  key or **Conf** softkey again to add Party 3 to the conference. Party 2 and Party 3 will connect with you to form a conference call.

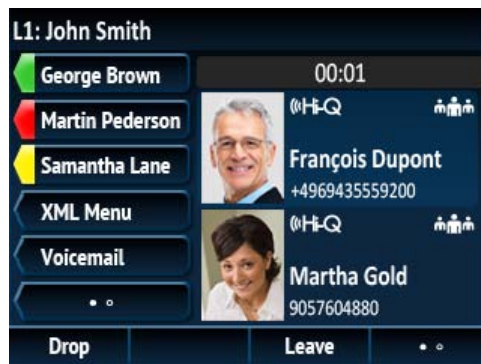

- To drop a party from the conference, use the ▲ or ▼ navigation keys to highlight the desired party and press the **Drop** key.

Creating a Conference Call By Joining Two Existing Calls



1. Ensure you are on an active call with one of the parties with whom you wish to create a conference (the other party should be placed on hold).

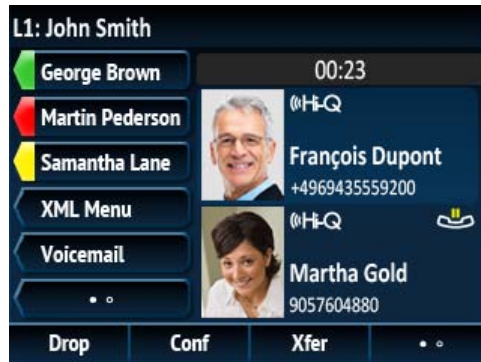

**Note:**

Direct conferencing can be performed in either the **Mult-View Call** screen or **Detailed View Call** screen.

2. Press the ▲ or ▼ navigation keys to highlight the party you wish to conference in.

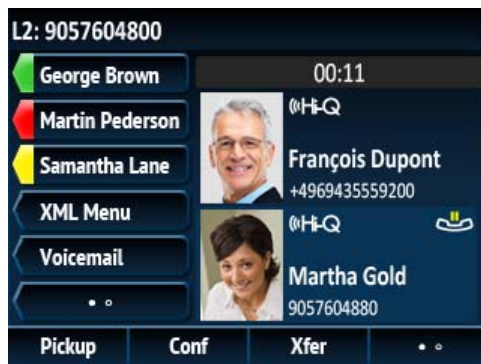

3. Press the  key or **Conf** softkey. The two parties will connect with you to form a conference call.

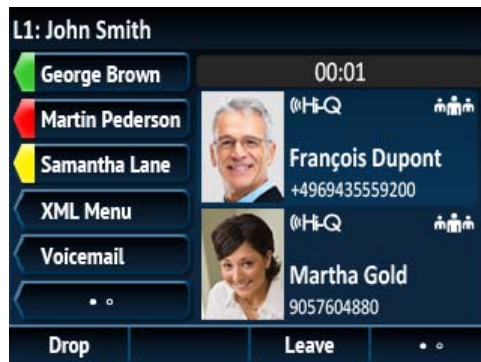

### Centralized Conferencing (for Sylanro and BroadSoft Call Managers)

The 6867i allows you to create multiple conferences with unlimited participants (depending on your server limitations) when your Administrator enables centralized conferencing.

If your Administrator does not enable centralized conferencing, then the 6867i uses local conferencing by default.

Your Administrator can configure centralized conferencing globally on all lines or on specific lines. Although, for the global setting to work, you must configure the lines with the applicable phone number.





#### Note:

When centralized conferencing is enabled on your phone, local conferencing (or three-way conferencing) works as indicated in “Local Conferencing” on page 116. Joining two active calls in a conference also works as indicated in “Creating a Conference Call By Joining Two Existing Calls” on page 119.

### Setting Up a Conference and Adding Multiple Parties (for Sylanro and BroadSoft Call Managers)



#### IP Phone UI



1. When you begin a conference, you are the first party in the conference (Party 1). Pickup the handset or press the  key. A line opens up.
2. Call Party 2 by dialing their number (or answer an incoming call of a party).
3. Wait for Party 2 to answer. When Party 2 answers, you can consult with them before adding them to Conference 1.
4. Press the  key or **Conf** softkey. A new line opens.
5. Enter the phone number of Party 3.
6. Wait for Party 3 to answer. When Party 3 answers, you can consult with them before adding them to the Conference 1.
7. Press the  key or **Conf** softkey again to add Party 3 to Conference 1. Party 2 and Party 3 will connect with you to form a conference call.
8. Press an available **Line** key or navigate to the **Line Selection** screen to place a new call using an available line (or answer an incoming call on an available line). If calling out, call Party 4.
9. Wait for Party 4 to answer. When Party 4 answers, you can consult with them before adding them to the conference.
10. Press the  key or **Conf** softkey.
11. Press the **Line** key or navigate to the **Line Selection** screen and highlight the line that has Conference 1.
12. Press the  key or **Conf** softkey to join all parties (Parties 1 through 4) on Conference 1.
13. To add more parties, repeat steps 8 through 12.

If any party in the conference hangs up (including the party that began the conference), all other parties in the conference are still connected.

### Setting Up Multiple Conferences (for Sylanro Call Manager only)

#### Note:

The 6867i is limited to 9 conferences (a single conference each on lines 1 through 9).

1. Start Conference 1 using the procedures in the previous section, "Setting Up a Conference and Adding Multiple Parties (for Sylanro and BroadSoft Call Managers)" on page 120.
2. When you are finished adding all required parties to Conference 1, press an available **Line** key or navigate to the **Line Selection** screen to place a new call using an available line to start Conference 2. You are Party 1 on Conference 2. Call Party 2.
3. When Party 2 answers, press the  key or **Conf** softkey.
4. Press an available **Line** key or navigate to the **Line Selection** screen to place a new call using an available line.
5. Call Party 3 for Conference 2.
6. When Party 3 answers, press the  key or **Conf** softkey to join Party 2, Party 3, and yourself to form a conference call. You now have two active conferences on two different lines.



#### Note:

When you are connected to multiple conference calls and you put a conference on hold, the conference may be on hold for a limited period of time before it is disconnected. Contact your System Administrator for more information.

If any party in a conference hangs up (including the party that began the conference), all other parties in the conference are still connected.

### Joining Additional Parties to Active Conferences

In centralized conferencing, you can join multiple incoming or outgoing calls to active conferences. Before following this procedure, at least one active conference must exist on your phone.

1. As Party 1, pickup the handset or press the  key. A line opens up.
2. Call Party 2 by dialing their number (or answer an incoming call of a party).
3. Wait for Party 2 to answer. When Party 2 answers, you can consult with them before adding them to the conference.
4. Press the  key or **Conf** softkey.
5. Press the **Line** key that contains the active conference or highlight a party that is part of the active conference and press the  key or **Conf** softkey again to join the parties to the active conference. For example, Line 1 and Line 2 both have active conferences. Pressing Line 1 or highlighting a party from Line 1 will join Party 1 and Party 2 to the conference on Line 1. Pressing Line 2 or highlight a party from Line 2 will Party 1 and Party 2 to the conference on Line 2.

### Ending a Conference and Transferring Remaining Parties

The 6867i allows a host to easily leave a three-way conference call without disrupting the connection of the other two remaining parties. If you are the host of a conference call and want to leave the conference, simply press the **Leave** softkey on the phone. Your phone leaves the three-way conference call but the remaining parties are still connected together.

## Ending Calls



#### IP Phone UI

To end a call, you first need to connect or reconnect to the call if not already connected (e.g. if your caller is on hold). Press  or the **Drop** softkey to end the call. If connected through the handset, you can also place the handset back on hook to end the call.

# Managing Calls

The 6867i has several features that make it easier to manage calls, and to keep track of your caller history, as well as your business and personal contacts.

These features include:

- Directory
- Callers List
- DND and Call Forward

## Directory

The Directory is your personal phone book, conveniently stored within your phone. You can enter up to 200 entries into the 6867i Directory by adding them manually or by saving the number and name from other lists stored on your phone. You can also dial directly from a directory entry. On the 6867i, you access the Directory by the  key.

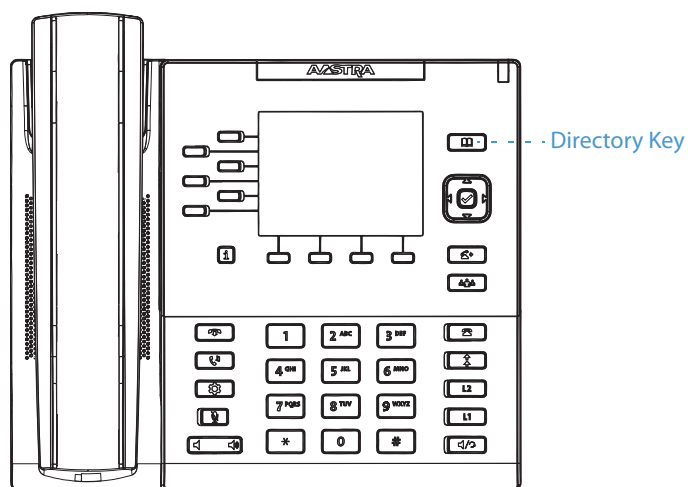

### Note:

For details on the total number of Directory entries currently stored on your phone, see [“Phone Status via IP Phone UI”](#) on [page 23](#).



## Accessing and Using Your Directory



### IP Phone UI

1. Press the key. The Directory displays the list of entries alphabetically. The following is an example of the Directory screen.

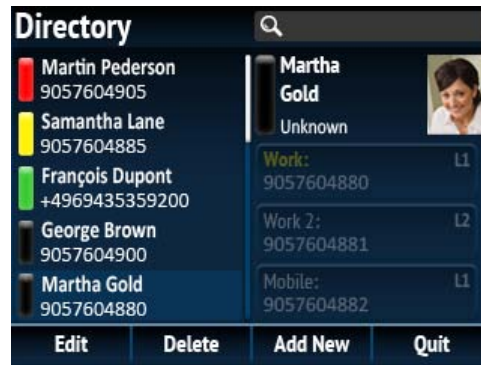

#### Note:

If the Directory is empty, a **Directory empty** message displays.

2. You can view entry details by pressing the ▼ and ▲ navigation keys to scroll through the list.
3. To search for an entry by name, press the dialpad number corresponding to the first letter of the name (for example, press **7** for the letter **P**). Continue to press the dialpad number to access other letters on the same key (for example, press **7** three times for **R**). If there are multiple entries under the same letters, you can use the ▼ and ▲ navigation keys to scroll through the list, or continue to press the next letters of the name to find a better match.
4. To dial the default number (i.e. the first number associated with the entry) press the button  
or  
Press the ► navigation key to move to the selection column, highlight a number using the ▼ and ▲ navigation keys, and press the button.
5. Press the **Directory** key, key, or **Quit** softkey to exit.

## Managing the Directory

From the Directory in the IP phone UI, you can perform the following:

- Add new entries to the Directory
- Add new numbers to an existing Directory entry
- Edit entries in the Directory
- Delete entries from the Directory
- Copy entries to the Directory

## Adding New Entries to the Directory



### IP Phone UI

1. Press the  key.
2. Press the **Add New** softkey.

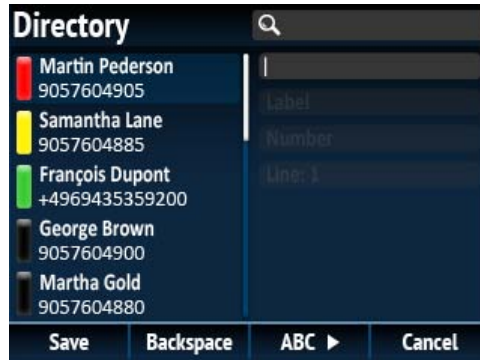

3. Using the dialpad keys, enter the name of the entry.  
**Note:**  
 If necessary, use the **Backspace** softkey to delete any characters, the ◀ and ▶ navigation keys to move your cursor, and the **ABC ▶** softkey to specify uppercase letters or lowercase letters.
4. Press the ▼ navigation key to move to the **Label** field and using the dialpad keys enter a label for the entry's number (e.g. Office, Home, Mobile, etc...)  
**Note:**  
 If necessary, use the **Backspace** softkey to delete any characters, the ◀ and ▶ navigation keys to move your cursor, and the **ABC ▶** softkey to specify uppercase letters or lowercase letters.
5. Press the ▼ navigation key to move to the **Number** field and using the dialpad keys enter the default number for the entry.  
**Note:**  
 If necessary, use the **Backspace** softkey to delete any characters and the navigation key to move your cursor.
6. Press the ▼ navigation key to move the **Line** field and using the ◀ and ▶ navigation keys set the default line that will be used to call the Directory entry.
7. Press the **Save** softkey to save your changes.

### Adding New Numbers to an Existing Directory Entry



#### IP Phone UI

1. Press the  key.
2. Press the ▼ and ▲ navigation keys to scroll through and highlight the respective Directory entry (or perform a search for the entry as per the steps outlined in “Accessing and Using Your Directory” on page 123).
3. Press the ► navigation key to move to the selection column of the respective entry.
4. Press the **Add New** softkey.

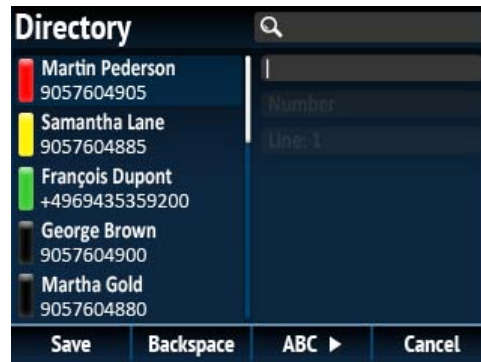

5. Using the dialpad keys enter a label for the new number (e.g. Office, Home, Mobile, etc...)
 

**Note:**  
If necessary, use the **Backspace** softkey to delete any characters, the ◀ and ▶ navigation keys to move your cursor, and the **ABC ►** softkey to specify uppercase letters or lowercase letters.
6. Press the ▼ navigation key to move to the **Number** field and using the dialpad keys enter the new number.
 

**Note:**  
If necessary, use the **Backspace** softkey to delete any characters and the ◀ and ▶ navigation keys to move your cursor.
7. Press the ▼ navigation key to move the **Line** field and using the ◀ and ▶ navigation keys set the default line that will be used to call the new number.
8. Press the **Save** softkey to save your changes.

**Note:**

You can store a maximum of 7 numbers for each Directory entry.

## Editing Entries in the Directory



### IP Phone UI

1. Press the key.
2. Press the ▼ and ▲ navigation keys to scroll through and highlight the respective Directory entry (or perform a search for the entry as per the steps outlined in “Accessing and Using Your Directory” on page 123).
3. Press the **Edit** softkey.

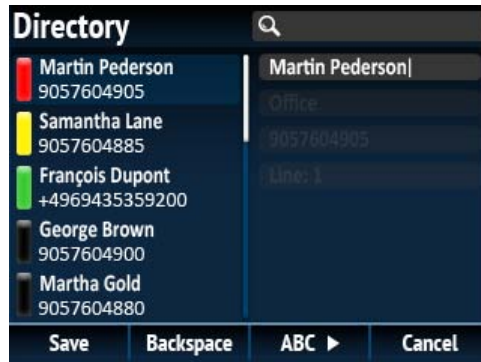

4. Using the dialpad keys, edit the name of the entry.
 

**Note:**  
If necessary, use the **Backspace** softkey to delete any characters, the ◀ and ▶ navigation keys to move your cursor, and the **ABC ▶** softkey to specify uppercase letters or lowercase letters.
5. Press the ▼ navigation key to move to the **Label** field and using the dialpad keys edit the label.
 

**Note:**  
If necessary, use the **Backspace** softkey to delete any characters, the ◀ and ▶ navigation keys to move your cursor, and the **ABC ▶** softkey to specify uppercase letters or lowercase letters.
6. Press the ▼ navigation key to move to the **Number** field and using the dialpad keys edit the number.
 

**Note:**  
If necessary, use the **Backspace** softkey to delete any characters and the navigation key to move your cursor.
7. Press the ▼ navigation key to move the **Line** field and using the ◀ and ▶ navigation keys edit the default line that will be used to call the Directory entry.
8. Press the **Save** softkey to save your changes.

## Deleting Entries from the Directory

You can delete entries from the Directory in the following ways:

- Delete a single entry in the Directory
- Delete a specific number attached to a Directory entry
- Delete all entries in the Directory

To delete a single entry in the Directory



### IP Phone UI

1. Press the key.
2. Press the ▼ and ▲ navigation keys to scroll through and highlight the respective Directory entry (or perform a search for the entry as per the steps outlined in “Accessing and Using Your Directory” on page 123).

- Press the **Delete** softkey. The following screen displays.

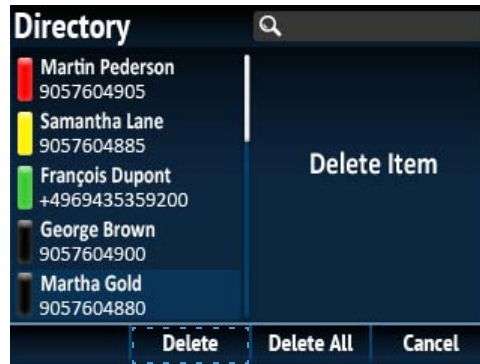

- Press the **Delete** softkey again to delete the Directory entry.
- Press the **Cancel** softkey to cancel the delete function.

*To delete a specific number attached to a Directory entry*

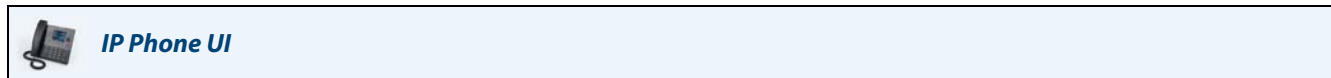

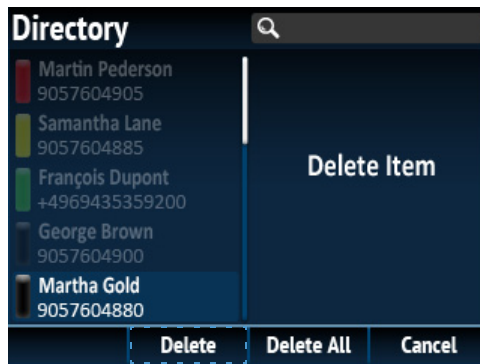

- Press the  key.
- Press the ▼ and ▲ navigation keys to scroll through and highlight the respective Directory entry (or perform a search for the entry as per the steps outlined in ["Accessing and Using Your Directory"](#) on page 123).
- Press the ► navigation key to move to the selection column of the respective entry and highlight a number using the ▼ and ▲ navigation keys.
- Press the **Delete** softkey. The following screen displays.

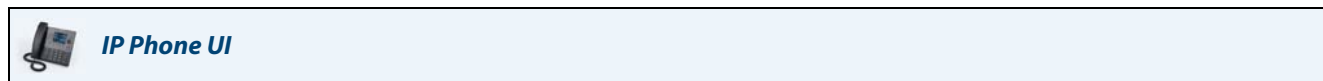

- Press the **Delete** softkey again to delete the number.
- Press the **Cancel** softkey to cancel the delete function.

To delete all entries in the Directory



1. Press the  key.
2. Press the **Delete** softkey. The following screen displays.

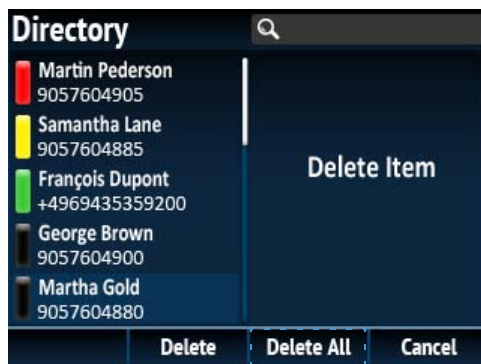

3. Press the **Delete All** softkey to delete all the entries in the Directory.
4. Press the **Cancel** softkey to cancel the delete function.

## Downloading the Directory to Your PC

You can download the Directory to your PC via the Aastra Web UI. The phone stores the *directorylist.csv* file to your PC in comma-separated value (CSV) format.

You can use any spreadsheet application to open the file for viewing. The following is an example of a *directorylist.csv* file in a spreadsheet application.

	A	B	C	D	E	F
1	John	41373	2			
2	Tim	41376	1			
3	Carol	4443245	1			
4	Tom	41356	3			
5						
6						
7						
8						
9						
10						
11						
12						

The file displays the name, phone number, and line number for each Directory entry.

### Note:

Your System Administrator can populate your IP phone Directory with server directory files. Contact your System Administrator for more details.

## Downloading the Directory



**Aastra Web UI**

1. Click on **Operation > Directory**.

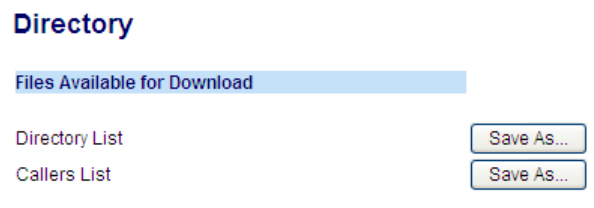

2. In the Directory field, click on **Save As...**  
A download window displays.
3. Click **OK**.
4. Enter the location on your computer where you want to download the Directory and click **Save**.  
The *directorylist.csv* file downloads to your computer.
5. Use a spreadsheet application to open and view the *directorylist.csv* file.

## Callers List





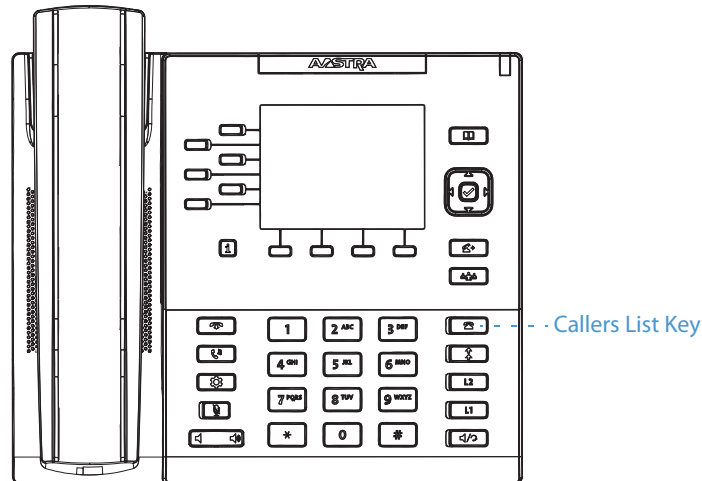

The Callers List is a stored log of your incoming calls. The 6867i telephone stores information on up to 200 incoming calls in the Callers List. Your telephone logs the name/number of the caller, when they last called, and if the call was answered or missed. Additional information such as the duration of the call, line used, and call features utilized during the call can also be viewed.

You can view, scroll, and delete line items in the Callers List from the IP phone UI as well as copy selected entries to the Directory. You can also dial out directly using a displayed entry in the Callers List.

On the 6867i, you access the Callers List by the  key.



The following table identifies and describes the various icons displayed in the Callers List.

Icon	Description
	Indicates an incoming call that was answered.
	Indicates an incoming call that was not answered.
	Indicates the incoming unanswered call is a new missed call. For more information see, <a href="#">“Copying Entries to the Directory”</a> on page 134.
Call Feature Indicators (in detailed view only)	
	Indicates the call was secured using TLS/SRTP encryption.
	Indicates the call was using Aastra Hi-Q™ audio.
	Indicates active VoIP recording was enabled and the call was recorded.

### Notes:

- When the Callers List is full, the oldest call records are deleted to accommodate the information of new callers.
- If the telephone number of an incoming or outgoing call matches a number that you have programmed with a name in a softkey or the Directory, the Callers List display the same name and number.
- For details on the total number of Callers List entries currently stored on your phone, see [“Phone Status via IP Phone UI”](#) on page 23.



## Accessing and Using the Callers List



### IP Phone UI

1. Press the  key.

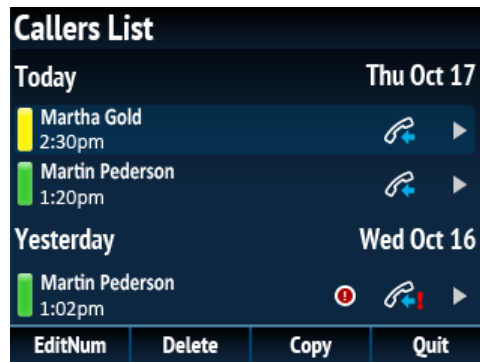





2. Use the ▲ and ▼ keys to scroll through the entries in the Callers List.
3. Press ► to see more detailed information about the Callers List entry.



#### Note:

The detailed view screen contains the picture ID of the caller (if available), the date and time of the incoming call, whether or not the call was answered, the line on which the call was received, call duration (if the call was answered), any applicable call feature indicators, and the caller ID details.

4. To dial the displayed number while in the Callers List, press the  button, press , lift the handset, or press any of the line keys.
5. To exit the Callers List, press the  key,  key, or the **Quit** softkey.

### Editing Entries in the Callers List

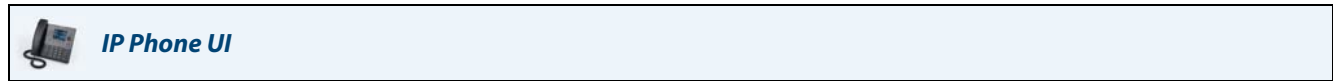

In the Callers List, pressing the **EditNum** softkey allows you to edit the entry's number prior to dialing out or copying to the Directory.



1. Press the  key.
2. Use the ▲ and ▼ keys to scroll through the entries in the Callers List.
3. Press the **EditNum** softkey.



4. Using the dialpad keys, edit the number.
 

**Note:**  
To move the cursor one digit to the right, press the ► navigation key. To erase one digit to the left of the cursor, press the **Backspace** softkey.
5. To dial the new number, press the  button, press , lift the handset, or press any of the line keys or
6. To copy the new number to the Directory, press the **Copy** softkey.

## Deleting Entries from the Callers List

You can delete individual entries from the Callers List or you can simply delete all entries in the Callers List.

To delete an individual entry from the Callers List



1. Press the  key.
2. Use the ▲ and ▼ keys to scroll through the entries in the Callers List.
3. Press the **Delete** softkey.

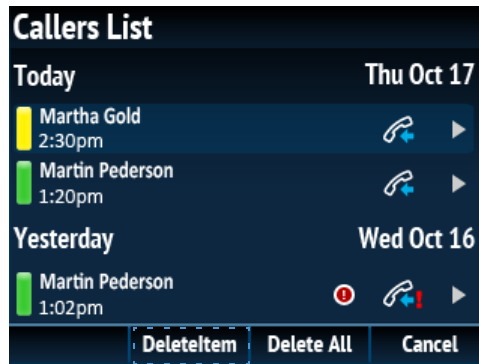

4. Press the **DeleteItem** softkey to erase the entry.

To delete all entries from the Callers List



1. Press the  key.
2. Use the ▲ and ▼ keys to scroll through the entries in the Callers List.
3. Press the **Delete** softkey.

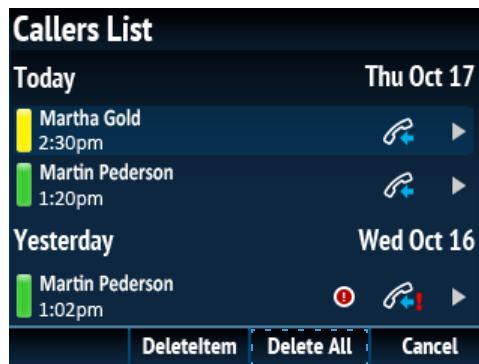

4. Press the **DeleteAll** softkey to erase all items.

## Copying Entries to the Directory



1. Press the  key.
2. Press the ▼ and ▲ navigation keys to scroll through and highlight the respective Callers List entry.

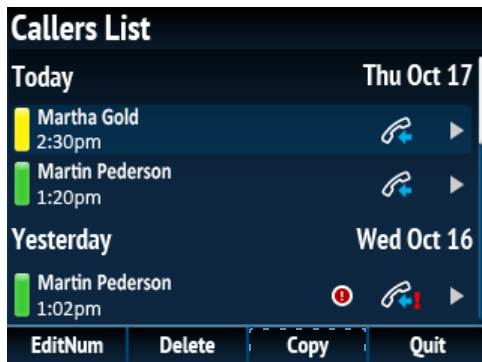

3. Press the **Copy** softkey.  
The entry is copied to the Directory.  
**Note:**  
If the contact's name already exists in the Directory but the number is different, press the **Replace** softkey to replace the contact's old number with the new number or press the **Merge** softkey to add the new number as an additional number while keeping the old number intact.

### Missed Calls Indicator

The IP phone has a missed calls indicator that increments the number of missed calls to the phone. The number of calls that have not been answered increment on the phone's Home screen as **# Missed Calls**.







As the number of unanswered calls increment, the phone numbers associated with the calls are stored in the Callers List. When the user accesses the Callers List, the missed calls message on the **Home** screen is cleared.

### Viewing Missed Call Details in the Callers List

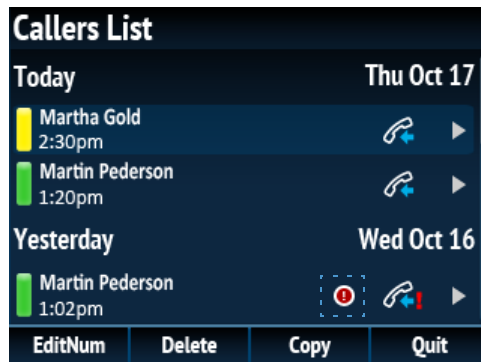

1. Press the  key.



2. Use the ▼ and ▲ navigation keys to scroll through the entries in the Callers List. The  icon indicates a new missed call.
3. To exit the Callers List, press the  key,  key or the **Quit** softkey. The missed calls message on the Home screen is cleared upon exit.

### Downloading the Callers List to Your PC

You can download the Callers List to your PC for viewing using the Aastra Web UI. When you download the Callers List, the phone stores the *callerlist.csv* file to your computer in comma-separated value (CSV) format.

You can use any spreadsheet application to open the file for viewing. The following is an example of a *callerlist.csv* file in a spreadsheet application. This file displays the name, phone number, and the line that the call came in on.

	A	B	C	D	E	F
1	John	41373	2			
2	Tim	41376	1			
3	Carol	4443245	1			
4	Tom	41356	3			
5						
6						
7						
8						
9						
10						
11						
12						

### Downloading the Callers List



1. Click on **Operation > Directory**.

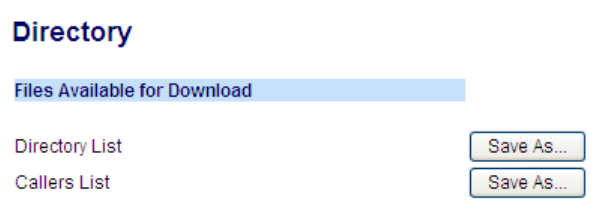

2. In the Callers List field, click on **Save As**.  
A download window displays.
3. Click **OK**.
4. Enter the location on your computer where you want to download the Callers List and click **Save**.  
The *callerlist.csv* file downloads to your computer.
5. Use a spreadsheet application to open and view the Callers List.

## DND and Call Forward

The 6867i has a feature that allows you to configure DND and Call Forward for multiple accounts on the phone. You can set specific modes for the way you want the phone to handle DND and Call Forward. The three modes you can set on the phone for these features are:

- Account
- Phone
- Custom

The following paragraphs describe account-based DND and Call Forward:

- DND Configuration
- Call Forward Configuration

### DND Configuration

DND is a feature on the phone that prevents the phone from ringing and receiving incoming calls. When DND is enabled with Call Forward, any incoming calls can be forwarded to your voicemail or another number. See [“Call Forward Configuration”](#) on [page 141](#) for more information about call forwarding to other numbers.

On the 6867i, you can set DND on the phone-side for a specific account or for all accounts on the phone. You can set three modes for DND using the Aastra Web UI at the path, *Basic Settings > Preferences > General > DND Key Mode: Account, Phone* (default), and *Custom*. DND performs according to the mode you set.

You can then configure a DND key (for the phone or for an expansion module) using the Aastra Web UI at the path, *Operation > Softkeys and XML* or *Operation > Expansion Module <N>*. You can toggle DND on and off by pressing the key, or by setting DND for a specific account at the path, *Basic Settings > Account Configuration*. Once you enable DND, the  icon displays on screen for the applicable account.



#### Note:

If there is only one account configured on the phone, then the mode setting is ignored and the phone behaves as if the mode was set to Phone.

The following describes the key behavior for each DND mode.

- Account: The DND key toggles the account in focus on the IP phone UI to on or off.
- Phone (default): The DND key toggles all accounts on the phone to on or off.
- Custom: The DND key displays custom screens on the IP phone UI. The user can select whether to enable/disable DND per account, enable DND on all accounts, or disable DND on all accounts.

The following table describes the key and Message Waiting Indicator (MWI) LEDs when you enable DND on the IP phone.

Key LED Behavior for All Modes (Left Softkeys Only)	MWI LED Behavior for All Modes
<b>DND key LED RED</b> if current account in focus has DND on. <b>DND key LED off</b> when current account in focus has DND disabled.	<b>MWI LED on</b> if current account in focus has DND on. <b>MWI LED off</b> if current account in focus has DND off.

**Note:**

If you make changes to the configuration for DND via the IP phone UI, you must refresh the Aastra Web UI screen to see the changes.

**Configuring a DND Key**

The following describes the process of configuring DND on your phone. To configure a DND key, see “Do Not Disturb (DND) Key” on page 67.

**Note:**

If there is no DND key configured or if it has been removed, DND is disabled on the IP phone.

**Configuring DND Using the Aastra Web UI**

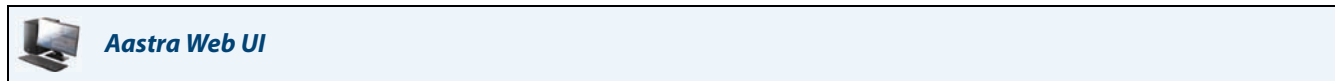

1. Click on **Basic Settings > Preferences > General**.

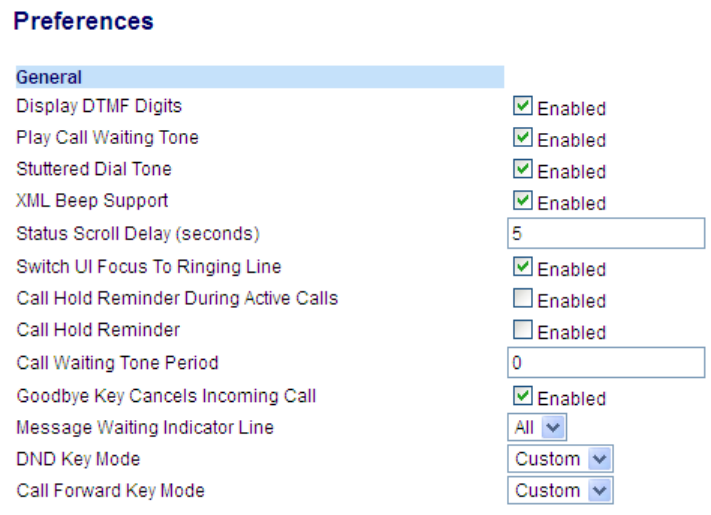

2. In the **DND Key Mode** field, select a DND mode to use on the phone.

- Account: Sets DND for a specific account. DND key toggles the account in focus on the phone to on or off.
- Phone (default): Sets DND on for all accounts on the phone. DND key toggles all accounts on the phone to on or off.
- Custom: Sets the phone to display custom screens after pressing the DND key that list the account(s) on the phone. The user can select a specific account for DND, turn DND on for all accounts, or turn DND off for all accounts.

**Notes:**

- If there is only one account configured on the phone, then the mode setting is ignored and the phone behaves as if the mode was set to Phone.
- Using the Aastra Web UI, if you change the **DND Key Mode** to Phone, all accounts synchronize to the current setting of Account 1.

3. Click **Save Settings**.

The changes takes affect immediately without a reboot.



4. Click on **Basic Settings > Account Configuration**.

**Account Configuration**

Account	DND	Call Forward	State	Value	No. Rings
1. John Smith	<input checked="" type="checkbox"/>	All	<input type="checkbox"/>	<input type="text"/>	
		Busy	<input checked="" type="checkbox"/>	4200	
		No Answer	<input type="checkbox"/>	<input type="text"/>	4 <input type="button" value="v"/>
2. J. Smith	<input type="checkbox"/>	All	<input type="checkbox"/>	<input type="text"/>	
		Busy	<input type="checkbox"/>	<input type="text"/>	
		No Answer	<input type="checkbox"/>	<input type="text"/>	4 <input type="button" value="v"/>

5. For each account, enable DND by placing a check mark in the box. Disable DND by unchecking the box.

**Notes:**

- If you selected Account or Custom mode in Step 2, you can enable/disable each account or all accounts as applicable. If you selected Phone mode, the first account allows you to change the DND status for all accounts.
- Number and name of accounts that display to this screen are dependant on the number and name of accounts configured on the phone. Only your Administrator can create accounts for your phone. Contact your Administrator for more information.

6. Click **Save Settings**.

The changes takes affect immediately without a reboot.

### Configuring DND Modes Using the IP Phone UI

After you add a DND key to your phone, you can toggle the DND state using this key on the phone. Use the following procedure to enable/disable DND on the IP phone.

The following procedures assume you have already configured a DND key AND assumes there are multiple accounts configured on the phone.

#### DND in Account Mode

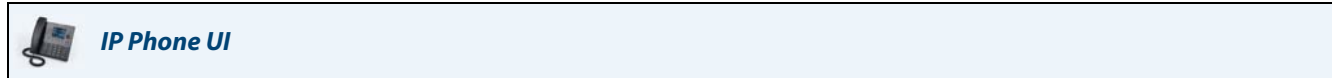

1. From the Home screen press the ► navigation key to move to the **Line Selection** screen.
2. Highlight the desired account using the ▼ and ▲ navigation keys.
3. Press the ◀ navigation key to go back to the **Home** screen
4. With the account in focus on **Home** screen, press the **DND** softkey to toggle DND on or off for the account.

#### DND in Phone Mode (Default)



1. From the **Home** screen, press the **DND** softkey to toggle DND on or off for all accounts on the phone.

**Note:**

Enabling DND in Phone mode toggles all accounts on the phone to DND on.

#### DND in Custom Mode



1. From the Home screen, press the **DND** softkey.  
The screen displays a list of the accounts on the phone and allows you to enable/disable a specific account or all accounts.

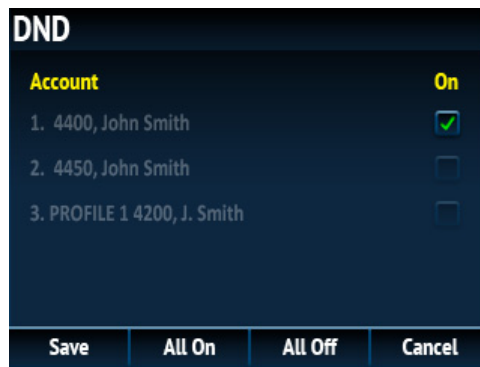

2. Use the ▼ and ▲ navigation keys to scroll through the accounts and press the  button to enable DND for the selected account.

**Note:**

Press the **All On** or **All Off** softkeys to quickly enable or disable DND for all accounts.

3. Press the **Save** softkey to save your changes.

## Call Forward Configuration

Call Forward on the IP phone allows incoming calls to be forwarded to another destination.

On the 6867i, you can set Call Forward on the phone-side for a specific account or for all accounts on the phone. You can set a Call Forward mode using the Aastra Web UI at the path, *Basic Settings > Preferences > General > Call Forward Key Mode: Account* (default), *Phone*, and *Custom*. Call Forward behaves according to the mode you set.

You can configure Call Forward using the Aastra Web UI at the path, *Basic Settings > Account Configuration*, or you can configure Call Forward using the IP phone UI at the path, *Options > Call Forward*.

Using the Aastra Web UI at the path, *Operation > Softkeys and XML* or *Operation > Programmable Keys*, you can also configure a **Call Forward** key for the phone (or for an expansion module) to use as a shortcut for accessing the Call Forward menu on the phone.

The following describes the behavior for each Call Forward mode.

- **Account (default):** The Account mode allows you to configure Call Forward on a per account basis. Pressing a configured **Call Forward** key applies to the account in focus.
- **Phone:** The Phone mode allows you to set the same Call Forward configuration for all accounts (All, Busy, and/or No Answer). When you configure the initial account, the phone applies the configuration to all other accounts. (In the Aastra Web UI, only the account you configured is enabled. All other accounts are greyed out but set to the same configuration.) Using the Aastra Web UI, if you make changes to that initial account, the changes apply to all accounts on the phone.
- **Custom:** The Custom mode allows you to configure Call Forward for a specific account or all accounts. You can configure a specific mode (All, Busy, and/or No Answer) for each account independently or all accounts. On the 6867i, you can set all accounts to **All On**, **All Off**, or copy the configuration for the account in focus to all other accounts using a **CopytoAll** softkey.

### Note:

If there is only one account configured on the phone, then the mode setting is ignored and the phone behaves as if the mode was set to Phone.

You can enable different Call Forward rules/modes independently (for example, you can set different phone numbers for Busy, All, and NoAnswer modes and then turn them on/off individually).

The following table describes the key and Message Waiting Indicator (MWI) LEDs when you enable Call Forward on the IP phone.

Key LED Behavior for All Modes (Left Softkeys Only)	MWI LED Behavior for All Modes
<b>Call Forward key LED RED</b> if any Call Forward mode is enabled for the account in focus.	<b>MWI LED on</b> if any Call Forward mode is enabled for the account in focus.
<b>Call Forward key LED off</b> if all Call Forward modes are disabled for the account in focus.	<b>MWI LED off</b> if all Call Forward modes are disabled for the account in focus.

### Note:

If you make changes to the configuration for Call Forward via the IP phone UI, you must refresh the Aastra Web UI screen to see the changes.

## Configuring a Call Forward Key

The following describes the process of configuring Call Forward on your phone. To configure a Call Forward key, see [“Call Forward Key”](#) on page 81.

Configuring Call Forward Using the Aastra Web UI

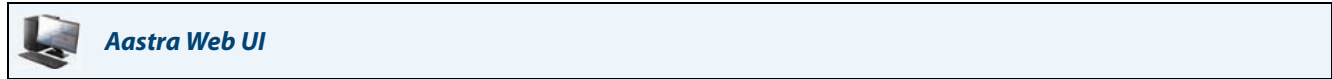

1. Click on **Basic Settings > Preferences > General.**

**Preferences**

**General**

Display DTMF Digits	<input checked="" type="checkbox"/> Enabled
Play Call Waiting Tone	<input checked="" type="checkbox"/> Enabled
Stuttered Dial Tone	<input checked="" type="checkbox"/> Enabled
XML Beep Support	<input checked="" type="checkbox"/> Enabled
Status Scroll Delay (seconds)	<input type="text" value="5"/>
Switch UI Focus To Ringing Line	<input checked="" type="checkbox"/> Enabled
Call Hold Reminder During Active Calls	<input type="checkbox"/> Enabled
Call Hold Reminder	<input type="checkbox"/> Enabled
Call Waiting Tone Period	<input type="text" value="0"/>
Goodbye Key Cancels Incoming Call	<input checked="" type="checkbox"/> Enabled
Message Waiting Indicator Line	All ▾
DND Key Mode	Custom ▾
Call Forward Key Mode	Custom ▾

2. In the **Call Forward Key Mode** field, select a call forward mode to use on the phone.
- **Account (default):** The Account mode allows you to configure Call Forward on a per account basis. Pressing a configured **Call Forward** key applies to the account in focus.
  - **Phone:** The Phone mode allows you to set the same Call Forward configuration for all accounts (All, Busy, and/or No Answer). When you configure the initial account, the phone applies the configuration to all other accounts. (In the Aastra Web UI, only the account you configured is enabled. All other accounts are greyed out but set to the same configuration.) Using the Aastra Web UI, if you make changes to that initial account, the changes apply to all accounts on the phone.
  - **Custom:** The Custom mode allows you to configure Call Forward for a specific account or all accounts. You can configure a specific state (All, Busy, and/or No Answer) for each account independently or all accounts. On the 6867i, you can set all accounts to **All On**, **All Off**, or copy the configuration for the account in focus to all other accounts using a **CopytoAll** softkey.

**Note:**

If there is only one account configured on the phone, then the mode setting is ignored and the phone behaves as if the mode was set to Phone.

3. Click **Save Settings.**  
The changes takes affect immediately without a reboot.

4. Click on **Basic Settings > Account Configuration**.

**Account Configuration**

Account	DND	Call Forward	State	Value	No. Rings
1. John Smith	<input checked="" type="checkbox"/>	All	<input type="checkbox"/>	<input type="text"/>	4 <input type="button" value="v"/>
		Busy	<input checked="" type="checkbox"/>	4200	
		No Answer	<input type="checkbox"/>	<input type="text"/>	
2. J. Smith	<input type="checkbox"/>	All	<input type="checkbox"/>	<input type="text"/>	4 <input type="button" value="v"/>
		Busy	<input type="checkbox"/>	<input type="text"/>	
		No Answer	<input type="checkbox"/>	<input type="text"/>	

The illustration above shows 2 accounts configured on the phone. Accounts must be set up by your System Administrator.

5. For each account, enable the Call Forward state by placing a check mark in one or more of the following **State** fields:

- All
- Busy
- No Answer

The All option forwards all incoming calls for this account to the specified phone number regardless of the state of the phone. The phone can be in the Busy or No Answer states, or can be in the idle state. The phone still forwards all calls to the specified number.

The Busy option call forwards incoming calls only if the account is in the busy state. The calls are forwarded to the specified phone number.

The No Answer option call forwards incoming calls only if the account rings but is not answered in the defined number of rings. The call gets forwarded to the specified number.

**Notes:**

You can use the Busy and No Answer states together using different forwarding phone numbers. If these states are enabled for an account (the All state is disabled), and the phone is in the busy state when a call comes in, the phone can forward the call to the specified phone number (for example, voicemail). If there is no answer on the phone after the specified number of rings, the phone can forward the call to a different specified number, such as a cell phone number.

6. For each account, in the **Value** field, enter the phone number for which you want the incoming calls to forward to if the phone is in the specified state.

If using the Account mode or Custom mode, you can enter different phone numbers for each account.

**Notes:**

- If you selected Account mode in Step 5, you can enable/disable each account or all accounts as applicable. You can enter different phone number for each enabled state.
- If you selected Custom mode, you can enable/disable each account or all accounts as applicable. You can enter different phone numbers for each enabled state.
- If you selected Phone mode, all accounts are set to the same Call Forward configuration (All, Busy, and/or No Answer) as Account 1 on the phone. In the Aastra Web UI, only Account 1 is enabled. All other accounts are greyed out but use the same configuration as Account 1.
- Using the Aastra Web UI, if you make changes to Account 1, the changes apply to all accounts on the phone. Using the IP phone UI, if you make changes to any other account other than Account 1, the changes also apply to all accounts on the phone. When enabling a Call Forward state, you must specify a phone number for the phone to Call Forward to. The number you specify applies to all accounts of the same mode.
- Number and name of accounts that display to this screen are dependant on the number and name of accounts configured on the phone. The name for the account is specified by your System Administrator. Contact your System Administrator for more information.



7. For the No Answer state, in the **No. Rings** field, enter the number of times that the account rings before forwarding the call to the specified number. Valid values are 1 through 20. Default is 1.  
When using the Account mode or Custom mode, you can enter a different number of rings for each account. If you use the Aastra Web UI to change the Call Forward Key Mode to Phone, all accounts synchronize to Account 1.
8. Click **Save Settings**.  
The changes take effect immediately without a reboot.

### Using Call Forward via the IP Phone UI

Once Call Forward is enabled on your phone, you can access the Call Forward menus by pressing a pre-configured **Call Forward** key, or by selecting *Options > Call Forward* from the IP phone UI.

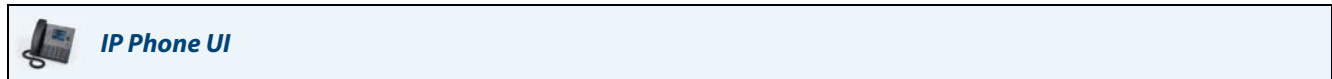
#### Call Forward in Account Mode



1. From the Home screen press the ► navigation key to move to the **Line Selection** screen.
2. Highlight the desired account using the ▼ and ▲ navigation keys.
3. Press the ◀ navigation key to go back to the **Home** screen
4. With the account in focus on **Home** screen, press the configured **Call Fwd** softkey or press , navigate to the **Call Forward** option and press the  button or **Select** softkey.  
The Call Forward screen displays for the account you selected.



5. Enter forwarding numbers using the dialpad keys for any of the following states:
  - All: Forwards all incoming calls for the respective account to the specified number.
  - Busy: Forwards incoming calls to a specified number if DND has been enabled for that account OR if the account is currently engaged in another call.
  - No Answer: Forwards incoming calls to a specified number if the call has not been answered for the specified number of rings.

**Notes:**



  - Pressing the ▼ navigation key moves the selection to the next field/checkbox.
  - If All and Busy and No Answer are all enabled (and/or if the account has DND enabled), the All settings take precedence over Busy and No Answer.
  - Pressing the **CopyToAll** key copies the call forward number of the Call Forward mode in focus to every Call Forward mode of that account. For example, if you have the cursor pointing at the All state and has a call forward phone number configured, pressing the **CopytoAll** key assigns the same phone number to the Busy and No Answer states as well.
6. If configuring a forwarding number for the No Answer state, navigate to the **No. Rings** field and press the ◀ or ► navigation keys to change the desired number of rings.

7. Using the ▼ navigation key, move to the **On** checkbox beside the respective Call Forward mode and press the  button to enable the Call Forward mode.
8. Press the **Save** softkey to save your changes.

### Call Forward in Phone Mode



#### IP Phone UI

1. Press the configured **Call Fwd** softkey or press , navigate to the **Call Forward** option and press the  button or **Select** softkey.  
The Call Forward screen displays and is applicable to all accounts configured on the phone.

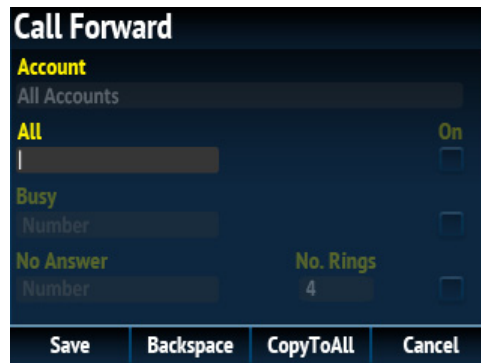

2. Enter forwarding numbers using the dialpad keys for any of the following states:
  - All: Forwards all incoming calls for the respective account to the specified number.
  - Busy: Forwards incoming calls to a specified number if DND has been enabled for that account OR if the account is currently engaged in another call.
  - No Answer: Forwards incoming calls to a specified number if the call has not been answered for the specified number of rings.

#### Notes:



- Pressing the ▼ navigation key moves the selection to the next field/checkbox.
  - If All and Busy and No Answer are all enabled (and/or if the account has DND enabled), the All settings take precedence over Busy and No Answer.
  - Pressing the **CopyToAll** key copies the call forward number of the Call Forward mode in focus to every Call Forward mode of that account. For example, if you have the cursor pointing at the All state and has a call forward phone number configured, pressing the **CopytoAll** key assigns the same phone number to the Busy and No Answer states as well.
3. If configuring a forwarding number for the No Answer state, navigate to the **No. Rings** field and press the ◀ or ▶ navigation keys to change the desired number of rings.
  4. Using the ▼ navigation key, move to the **On** checkbox beside the respective Call Forward mode and press the  button to enable the Call Forward mode.
  5. Press the **Save** softkey to save your changes.

#### Note:

In **Phone** mode, the configuration applies to all the accounts on the phone.

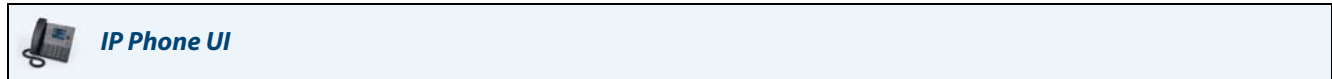
Call Forward in Custom Mode



1. Press the configured **Call Fwd** softkey or press  , navigate to the **Call Forward** option and press the  button or **Select** softkey.  
The Call Forward screen displays.



2. Press the ◀ or ▶ navigation keys to change to the desired account.  
**Note:**  
Select **All Accounts** if you want your changes to be made to all the accounts configured on the phone.
3. Enter forwarding numbers using the dialpad keys for any of the following states:
  - All: Forwards all incoming calls for the respective account to the specified number.
  - Busy: Forwards incoming calls to a specified number if DND has been enabled for that account OR if the account is currently engaged in another call.
  - No Answer: Forwards incoming calls to a specified number if the call has not been answered for the specified number of rings.**Notes:**
  - Pressing the ▼ navigation key moves the selection to the next field/checkbox.
  - If All and Busy and No Answer are all enabled (and/or if the account has DND enabled), the All settings take precedence over Busy and No Answer.
  - Pressing the **CopyToAll** key copies the call forward number of the Call Forward mode in focus to every Call Forward mode of that account. For example, if you have the cursor pointing at the All state and has a call forward phone number configured, pressing the **CopytoAll** key assigns the same phone number to the Busy and No Answer states as well.
4. If configuring a forwarding number for the No Answer state, navigate to the **No. Rings** field and press the ◀ or ▶ navigation keys to change the desired number of rings.
5. Using the ▼ navigation key, move to the **On** checkbox beside the respective Call Forward mode and press the  button to enable the Call Forward mode.
6. Press the **Save** softkey to save your changes.



# Additional Features

This section describes additional features you can use on the 6867i phone.

## Display DTMF Digits

A feature on the 6867i phone allows users to enable or disable DTMF (dual-tone multi-frequency) digits to display to the IP phone when using the dialpad to dial, or when dialing from a softkey or expansion module key.

DTMF is the signal sent from the phone to the network that you generate when you press the phone's touch keys. This is also known as touchtone dialing. Each key you press on your phone generates two tones of specific frequencies. One tone is generated from a high-frequency group of tones and the other from a low frequency group.

If you enable the **Display DTMF Digits** parameter, the digits you are dialing from the dialpad or softkey display to the IP phone's LCD display. This parameter is disabled by default (no digits display when dialing).

You can enable the **Display DTMF Digits** parameter using the Aastra Web UI.

### Configuring Display of DTMF Digits



#### Aastra Web UI

1. Click on **Basic Settings > Preferences > General**.

Preferences	
<b>General</b>	
Display DTMF Digits	<input checked="" type="checkbox"/> Enabled
Play Call Waiting Tone	<input checked="" type="checkbox"/> Enabled
Stuttered Dial Tone	<input checked="" type="checkbox"/> Enabled
XML Beep Support	<input checked="" type="checkbox"/> Enabled
Status Scroll Delay (seconds)	<input type="text" value="5"/>
Switch UI Focus To Ringing Line	<input checked="" type="checkbox"/> Enabled
Call Hold Reminder During Active Calls	<input type="checkbox"/> Enabled
Call Hold Reminder	<input type="checkbox"/> Enabled
Call Waiting Tone Period	<input type="text" value="0"/>
Goodbye Key Cancels Incoming Call	<input checked="" type="checkbox"/> Enabled
Message Waiting Indicator Line	<input type="text" value="All"/>
DND Key Mode	<input type="text" value="Custom"/>
Call Forward Key Mode	<input type="text" value="Custom"/>

2. Enable the **Display DTMF Digits** field by checking the check box.  
Disable this field by unchecking the box (default is disabled).
3. Click **Save Settings** to save your settings.

## Play Call Waiting Tone

You can enable or disable the playing of a call waiting tone when a caller is on an active call and a new call comes into the phone.

You can configure this feature using the Aastra Web UI.

### Configuring Call Waiting Tone

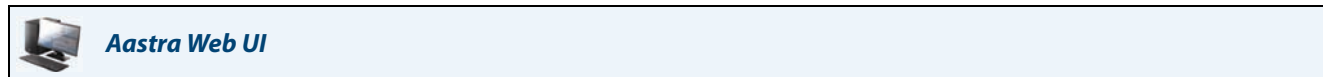

1. Click on **Basic Settings > Preferences > General**.

**Preferences**

**General**

Display DTMF Digits	<input checked="" type="checkbox"/> Enabled
Play Call Waiting Tone	<input checked="" type="checkbox"/> Enabled
Stuttered Dial Tone	<input checked="" type="checkbox"/> Enabled
XML Beep Support	<input checked="" type="checkbox"/> Enabled
Status Scroll Delay (seconds)	<input type="text" value="5"/>
Switch UI Focus To Ringing Line	<input checked="" type="checkbox"/> Enabled
Call Hold Reminder During Active Calls	<input type="checkbox"/> Enabled
Call Hold Reminder	<input type="checkbox"/> Enabled
Call Waiting Tone Period	<input type="text" value="0"/>
Goodbye Key Cancels Incoming Call	<input checked="" type="checkbox"/> Enabled
Message Waiting Indicator Line	All ▾
DND Key Mode	Custom ▾
Call Forward Key Mode	Custom ▾

2. The **Play Call Waiting Tone** field is enabled by default. To disable this field, uncheck the box.
3. Click **Save Settings** to save your settings.

## Stuttered Dial Tone

You can enable or disable the playing of a stuttered dial tone when there is a message waiting on the IP phone. You can configure this feature using the Aastra Web UI.

### Configuring Stuttered Dial Tone



#### Aastra Web UI

1. Click on **Basic Settings > Preferences > General**.

**Preferences**

**General**

Display DTMF Digits	<input checked="" type="checkbox"/> Enabled
Play Call Waiting Tone	<input checked="" type="checkbox"/> Enabled
Stuttered Dial Tone	<input checked="" type="checkbox"/> Enabled
XML Beep Support	<input checked="" type="checkbox"/> Enabled
Status Scroll Delay (seconds)	<input type="text" value="5"/>
Switch UI Focus To Ringing Line	<input checked="" type="checkbox"/> Enabled
Call Hold Reminder During Active Calls	<input type="checkbox"/> Enabled
Call Hold Reminder	<input type="checkbox"/> Enabled
Call Waiting Tone Period	<input type="text" value="0"/>
Goodbye Key Cancels Incoming Call	<input checked="" type="checkbox"/> Enabled
Message Waiting Indicator Line	All ▾
DND Key Mode	Custom ▾
Call Forward Key Mode	Custom ▾

2. The **Stuttered Dial Tone** field is enabled by default. To disable this field, uncheck the box.
3. Click **Save Settings** to save your settings.

## XML Beep Support

Using the Aastra Web UI, you can enable or disable a beep to be audible when the phone receives an XML application using the **XML Beep Support** field at the path *Basic Settings > Preferences > General*. If you disable this feature, then no beep is heard when the XML application arrives to the phone.

If your System Administrator has set a value for this feature in a custom XML application or in the configuration files, the value you set in the Aastra Web UI overrides the Administrator's setting. Setting and saving the value in the Aastra Web UI applies to the phone immediately.

### Configuring XML Beep Support



#### Aastra Web UI

1. Click on **Basic Settings > Preferences > General**.

**Preferences**

**General**

Display DTMF Digits	<input checked="" type="checkbox"/> Enabled
Play Call Waiting Tone	<input checked="" type="checkbox"/> Enabled
Stuttered Dial Tone	<input checked="" type="checkbox"/> Enabled
XML Beep Support	<input checked="" type="checkbox"/> Enabled
Status Scroll Delay (seconds)	<input type="text" value="5"/>
Switch UI Focus To Ringing Line	<input checked="" type="checkbox"/> Enabled
Call Hold Reminder During Active Calls	<input type="checkbox"/> Enabled
Call Hold Reminder	<input type="checkbox"/> Enabled
Call Waiting Tone Period	<input type="text" value="0"/>
Goodbye Key Cancels Incoming Call	<input checked="" type="checkbox"/> Enabled
Message Waiting Indicator Line	<input type="text" value="All"/>
DND Key Mode	<input type="text" value="Custom"/>
Call Forward Key Mode	<input type="text" value="Custom"/>

2. The **XML Beep Support** field is enabled by default. To disable this field, uncheck the box.
3. Click **Save Settings**.

## Status Scroll Delay

Using the Aastra Web UI, you can specify a scroll delay option that allows you to set the time delay, in seconds, between the scrolling of each status message on the phone. You can specify this setting in the **Status Scroll Delay (seconds)** field at the path *Basic Settings > Preferences > General*. The default time is 5 seconds for each message to display before scrolling to the next message. You can increase or decrease this time as required. Setting and saving the value in the Aastra Web UI applies to the phone immediately.

### Configuring Status Scroll Delay

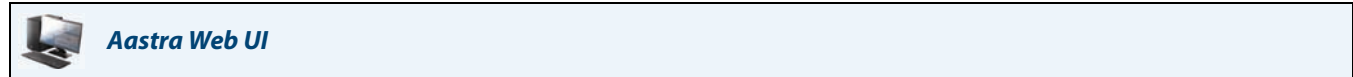

1. Click on **Basic Settings > Preferences > General**.

**Preferences**

**General**

Display DTMF Digits	<input checked="" type="checkbox"/> Enabled
Play Call Waiting Tone	<input checked="" type="checkbox"/> Enabled
Stuttered Dial Tone	<input checked="" type="checkbox"/> Enabled
XML Beep Support	<input checked="" type="checkbox"/> Enabled
Status Scroll Delay (seconds)	<input type="text" value="5"/>
Switch UI Focus To Ringing Line	<input checked="" type="checkbox"/> Enabled
Call Hold Reminder During Active Calls	<input type="checkbox"/> Enabled
Call Hold Reminder	<input type="checkbox"/> Enabled
Call Waiting Tone Period	<input type="text" value="0"/>
Goodbye Key Cancels Incoming Call	<input checked="" type="checkbox"/> Enabled
Message Waiting Indicator Line	All ▾
DND Key Mode	Custom ▾
Call Forward Key Mode	Custom ▾

2. Enter a value in the **Status Scroll Delay (seconds)** field. Valid values are: 1 to 25 seconds. Default is 5 seconds.
3. Click **Save Settings** to save our changes.

## Switch UI Focus to Ringing Line

You can configure a feature on the 6867i that controls the behavior of the phone when it receives an incoming call when it is already in a connected call. When a call comes into the phone, and the phone is already on a connected call, the phone switches focus to the ringing line to enable the user to see who is calling them. You can turn off this functionality so that the phone stays focused on the connected call. You can do this using the **Switch Focus to Ringing Line** parameter in the Aastra Web UI.

### Configuring Switch Focus to Ringing Line



Aastra Web UI

1. Click on **Basic Settings > Preferences > General**.

**Preferences**

**General**

Display DTMF Digits	<input checked="" type="checkbox"/> Enabled
Play Call Waiting Tone	<input checked="" type="checkbox"/> Enabled
Stuttered Dial Tone	<input checked="" type="checkbox"/> Enabled
XML Beep Support	<input checked="" type="checkbox"/> Enabled
Status Scroll Delay (seconds)	<input type="text" value="5"/>
Switch UI Focus To Ringing Line	<input checked="" type="checkbox"/> Enabled
Call Hold Reminder During Active Calls	<input type="checkbox"/> Enabled
Call Hold Reminder	<input type="checkbox"/> Enabled
Call Waiting Tone Period	<input type="text" value="0"/>
Goodbye Key Cancels Incoming Call	<input checked="" type="checkbox"/> Enabled
Message Waiting Indicator Line	All ▾
DND Key Mode	Custom ▾
Call Forward Key Mode	Custom ▾

2. The **Switch Focus to Ringing Line** field is enabled by default. To disable this field, uncheck the box.
3. Click **Save Settings** to save your settings.

## Call Hold Reminder During Active Calls

The IP phones allow you to enable or disable the ability for the phone to initiate a continuous reminder tone on the active call when another call is on hold. For example, when this feature is enabled, and the call on Line 1 is on hold, and then the you answer a call on Line 2 and stay on that line, a reminder tone is played in the active audio path on Line 2 to remind you that there is still a call on hold on Line 1.

When this feature is disabled, a ring splash is heard when the active call hangs up and there is still a call on hold.

You can enable or disable this feature using the **Call Hold Reminder During Active Calls** parameter in the Aastra Web UI.

### Configuring Call Hold Reminder During Active Calls



#### Aastra Web UI

1. Click on **Basic Settings > Preferences > General**.

**Preferences**

**General**

Display DTMF Digits	<input checked="" type="checkbox"/> Enabled
Play Call Waiting Tone	<input checked="" type="checkbox"/> Enabled
Stuttered Dial Tone	<input checked="" type="checkbox"/> Enabled
XML Beep Support	<input checked="" type="checkbox"/> Enabled
Status Scroll Delay (seconds)	<input type="text" value="5"/>
Switch UI Focus To Ringing Line	<input checked="" type="checkbox"/> Enabled
Call Hold Reminder During Active Calls	<input type="checkbox"/> Enabled
Call Hold Reminder	<input type="checkbox"/> Enabled
Call Waiting Tone Period	<input type="text" value="0"/>
Goodbye Key Cancels Incoming Call	<input checked="" type="checkbox"/> Enabled
Message Waiting Indicator Line	<input type="text" value="All"/>
DND Key Mode	<input type="text" value="Custom"/>
Call Forward Key Mode	<input type="text" value="Custom"/>

2. The **Call Hold Reminder During Active Calls** field is disabled by default. To enabled this field, check the box.  
When this feature is enabled, a reminder tone is heard on the active call when another call is on hold. When disabled, a ring splash is heard when the active call hangs up and there is still a call on hold.
3. Click **Save Settings**.

## Call Hold Reminder (on single hold)

On the 6867i IP phone, you can enable or disable a feature that will start the reminder ring splash timer as soon as you put a call on hold (even when no other calls are active on the phone). When enabled, the phone initiates a reminder ring splash periodically for the single call on hold. When disabled, no reminder ring splash is audible.

You can enable or disable this feature using the **Call Hold Reminder** parameter in the Aastra Web UI.

### Configuring Call Hold Reminder

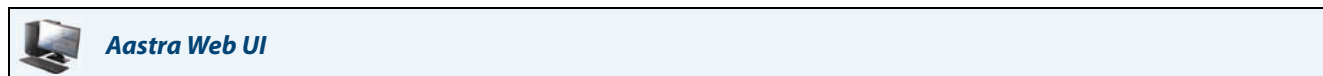

1. Click on **Basic Settings > Preferences > General**

**Preferences**

**General**

Display DTMF Digits	<input checked="" type="checkbox"/> Enabled
Play Call Waiting Tone	<input checked="" type="checkbox"/> Enabled
Stuttered Dial Tone	<input checked="" type="checkbox"/> Enabled
XML Beep Support	<input checked="" type="checkbox"/> Enabled
Status Scroll Delay (seconds)	<input type="text" value="5"/>
Switch UI Focus To Ringing Line	<input checked="" type="checkbox"/> Enabled
Call Hold Reminder During Active Calls	<input type="checkbox"/> Enabled
Call Hold Reminder	<input type="checkbox"/> Enabled
Call Waiting Tone Period	<input type="text" value="0"/>
Goodbye Key Cancels Incoming Call	<input checked="" type="checkbox"/> Enabled
Message Waiting Indicator Line	All ▾
DND Key Mode	Custom ▾
Call Forward Key Mode	Custom ▾

2. The **Call Hold Reminder** field is disabled by default. To enable this field, check the box.  
When this feature is enabled, the reminder ring splash timer starts as soon as you put a call on hold (even when no other calls are active on the phone). The phone initiates a reminder ring splash periodically for the single call on hold. When disabled, no reminder ring splash is audible.
3. Click **Save Settings**.



## Call Waiting Tone Period

You can specify a specific time period (in seconds) for the call waiting tone to play at regular intervals on an active call using the parameter **Call Waiting Tone Period**. A value of 0 is the default and plays the call waiting tone only once on the active call. When the incoming caller hangs up, the call waiting tone stops on the existing active call.

You can enable or disable this feature in the Aastra Web UI.

### Configuring Call Waiting Tone Period



#### Aastra Web UI

1. Click on **Basic Settings > Preferences > General**

**Preferences**



**General**

Display DTMF Digits	<input checked="" type="checkbox"/> Enabled
Play Call Waiting Tone	<input checked="" type="checkbox"/> Enabled
Stuttered Dial Tone	<input checked="" type="checkbox"/> Enabled
XML Beep Support	<input checked="" type="checkbox"/> Enabled
Status Scroll Delay (seconds)	<input type="text" value="5"/>
Switch UI Focus To Ringing Line	<input checked="" type="checkbox"/> Enabled
Call Hold Reminder During Active Calls	<input type="checkbox"/> Enabled
Call Hold Reminder	<input type="checkbox"/> Enabled
Call Waiting Tone Period	<input type="text" value="0"/>
Goodbye Key Cancels Incoming Call	<input checked="" type="checkbox"/> Enabled
Message Waiting Indicator Line	All ▾
DND Key Mode	Custom ▾
Call Forward Key Mode	Custom ▾

2. In the **Call Waiting Tone Period** field, enter a time period, in seconds, that the call waiting tone will be audible on an active call when another call comes in. Default is 0 seconds.  
When enabled, the call waiting tone plays at regular intervals for the amount of time set for this parameter. For example, if set to 30 the call waiting tone plays every 30 seconds. When set to 0, the call waiting tone is audible only once on the active call.
3. Click **Save Settings**.

## Goodbye Key Cancels Incoming Calls

The 6867i has a feature that allows you to configure the **Goodbye** key to drop a second incoming call or ignore incoming calls presented to the phone when you are on an active call. The parameter is called **Goodbye Key Cancels Incoming Call** and is configurable via the Aastra Web UI.

If you enable this parameter, which is the default, pressing the  key rejects calls coming into the phone while you are on an active call. When you disable this parameter, pressing the  key hangs up the active call.

### Configuring Goodbye Key to Cancel Incoming Calls



1. Click on **Basic Settings > Preferences > General**.

**Preferences**

**General**

Display DTMF Digits	<input checked="" type="checkbox"/> Enabled
Play Call Waiting Tone	<input checked="" type="checkbox"/> Enabled
Stuttered Dial Tone	<input checked="" type="checkbox"/> Enabled
XML Beep Support	<input checked="" type="checkbox"/> Enabled
Status Scroll Delay (seconds)	<input type="text" value="5"/>
Switch UI Focus To Ringing Line	<input checked="" type="checkbox"/> Enabled
Call Hold Reminder During Active Calls	<input type="checkbox"/> Enabled
Call Hold Reminder	<input type="checkbox"/> Enabled
Call Waiting Tone Period	<input type="text" value="0"/>
Goodbye Key Cancels Incoming Call	<input checked="" type="checkbox"/> Enabled
Message Waiting Indicator Line	All ▾
DND Key Mode	Custom ▾
Call Forward Key Mode	Custom ▾

2. The **Goodbye Key Cancels Incoming Call** field is enabled by default. To disable this field, uncheck the box.
3. Click **Save Settings** to save your settings.

## Message Waiting Indicator

You can configure the Message Waiting Indicator (MWI) to illuminate for a specific line or for all lines. For example, if you configure the MWI LED on Line 2 only, the LED illuminates if a voicemail is pending on Line 2. If you configure the MWI LED for all lines, the LED illuminates if a voicemail is pending on any line on the phone (lines 1 through 9).

You configure the MWI using the Aastra Web UI.

### Configuring Message Waiting Indicator



#### Aastra Web UI

1. Click on **Basic Settings > Preferences > General**.

**Preferences**

**General**

Display DTMF Digits	<input checked="" type="checkbox"/> Enabled
Play Call Waiting Tone	<input checked="" type="checkbox"/> Enabled
Stuttered Dial Tone	<input checked="" type="checkbox"/> Enabled
XML Beep Support	<input checked="" type="checkbox"/> Enabled
Status Scroll Delay (seconds)	<input type="text" value="5"/>
Switch UI Focus To Ringing Line	<input checked="" type="checkbox"/> Enabled
Call Hold Reminder During Active Calls	<input type="checkbox"/> Enabled
Call Hold Reminder	<input type="checkbox"/> Enabled
Call Waiting Tone Period	<input type="text" value="0"/>
Goodbye Key Cancels Incoming Call	<input checked="" type="checkbox"/> Enabled
Message Waiting Indicator Line	All ▾
DND Key Mode	Custom ▾
Call Forward Key Mode	Custom ▾

2. The **Message Waiting Indicator Line** field is set to **ALL** lines by default. If required, change the setting to a specific line by selecting a line from the list. Valid values are **All** and lines **1** through **9**.
3. Click **Save Settings**.

## Incoming Intercom Call Features

By default, the IP phone allows incoming intercom calls to be automatically answered without having to set up an Icom key on your phone. The phone automatically plays a warning tone when it receives an incoming intercom call. It also mutes the microphone. If the intercom call comes into the phone while an active call is already present, the phone puts the active call on hold and answers the intercom call.

You can change the behavior of how the phone handles incoming intercom calls by enabling/disabling the following parameters using the Aastra Web UI:

- Auto Answer
- Microphone Mute
- Play Warning Tone
- Allow Barge In

### Auto-Answer/Play Warning Tone

The auto-answer feature on the IP phone allows you to enable or disable automatic answering for an Intercom call. If **Auto-Answer** is enabled, the phone automatically answers an incoming intercom call. If **Play Warning Tone** is also enabled, the phone plays a tone to alert you before answering the intercom call. If **Auto-Answer** is disabled, the phone treats the incoming intercom call as a normal call. **Auto-Answer** and **Play Warning Tone** are enabled by default.

**Note:**

Your Administrator can set a time period delay before the phone automatically answers. Contact your System Administrator for more information.

### Microphone Mute

You can mute or unmute the microphone on the IP phone for intercom calls made by the originating caller. If you want to mute the intercom call, you enable this feature. If you want to unmute (or hear the intercom call), you disable this feature. **Microphone Mute** is enabled by default.

### Allow Barge In

You can configure whether or not the IP phone allows an incoming intercom call to interrupt an active call. The **Allow Barge In** parameter controls this feature. When you enable this parameter, which is the default value, an incoming intercom call takes precedence over any active call, by placing the active call on hold and automatically answering the intercom call. When you disable this parameter, and there is an active call, the phone treats an incoming intercom call like a normal call and plays the call warning tone. **Allow Barge In** is enabled by default.

## Configuring Incoming Intercom Settings



### Aastra Web UI

1. Click on **Basic Settings > Preferences > Incoming Intercom Settings**.

Incoming Intercom Settings	
Auto-Answer	<input checked="" type="checkbox"/> Enabled
Microphone Mute	<input checked="" type="checkbox"/> Enabled
Play Warning Tone	<input checked="" type="checkbox"/> Enabled
Allow Barge In	<input checked="" type="checkbox"/> Enabled

2. The **Auto-Answer** field is enabled by default. The automatic answering feature is turned on for the IP phone for answering Intercom calls. To disable this field, uncheck the box.  
**Note:**  
 If the Auto-Answer field is not checked (disabled), the phone treats the incoming intercom call as a normal call.
3. The **Microphone Mute** field is enabled by default. The microphone is muted on the IP phone for Intercom calls made by the originating caller. To disable this field, uncheck the box.
4. The **Play Warning Tone** field is enabled by default. If Auto-Answer is enabled, the phone plays a warning tone when it receives in incoming intercom call. To disable this field, uncheck the box.
5. The **Allow Barge In** field is enabled by default. If Allow Barge In is enabled, the phone puts an active call on hold and answers the incoming Intercom call. To disable this field, uncheck the box.
6. Click **Save Settings** to save your settings.

## Group RTP Paging

You can configure the phone to allow it to receive a Real Time Transport Protocol (RTP) stream from pre-configured multicast address(es) without involving SIP signalling. This is called Group Paging on the IP phones. You can specify up to 5 multicast addresses that the phone listens for on the network. This feature is configurable using the Aastra Web UI only. The 6867i in the local network listens for RTP on the pre-configured multicast address. The Phone displays the Paging message to the phone's LCD. It uses the G711 uLaw CODEC for multicast RTP.

The recipient can drop the incoming page if required. The recipient can also set DND to ignore any incoming pages.

For incoming RTP multicasts, the ringing display is dependant on the setting for the **Allow Barge In** parameter (see "Allow Barge In" on page 158). If this parameter is disabled, and there is no other call on the phone, then the paging is automatically played via the default audio device.

If there is an existing call on the phone, the call initially displays in the ringing state. The user has the option to accept/ignore the call. If the **Allow Barge In** parameter is enabled, the RTP multicast call barges in, and any existing calls are put on hold.

If an RTP multicast session already exists on the phone, and the phone receives another incoming RTP multicast session, the priority is given to the first multicast session and the second multicast session is ignored. The behavior for the incoming calls in this case is also based on the setting for the **Allow Barge In** parameter. The incoming call is handled as if there were an existing call already on the phone.

### Configuring Group RTP Paging



1. Click on **Basic Settings** > **Preferences** > **Group Paging RTP Settings**.

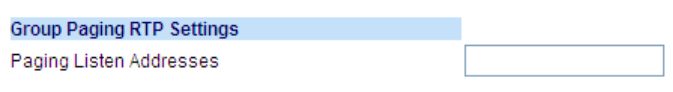

2. In the **Paging Listen Addresses** text box, enter the multicast IP address(es) and port number on which the phone listens for incoming multicast RTP packets.

Enter the IP address in dotted decimal format.

(for example, 239.0.1.15:10000,239.0.1.20:15000)

You can enter up to 5 listening multicast addresses.

If this field is blank, the paging listening capability is disabled on the phone.

**Notes:**

- Recipient of a paging call can set a global DND to ignore any incoming pages.
- For incoming paging, the phone uses the Intercom configuration settings. The incoming page is dependant on the **Allow Barge In** parameter setting and the idling/on call state.

3. Click **Save Settings**.

## Shared Call Appearance (SCA) Call Bridging

Shared Call Appearance (SCA) is when incoming calls are presented to multiple phones simultaneously. For example, it is the ability to assign the boss' extension to a button on the secretary's phone. Calls can be transferred between two phones with the same extension button by simply putting the call on hold at one phone and picking it up on the other. Status LEDs light and flash in unison, allowing all people sharing the extension to see the status at a glance.

The phones include an enhanced SCA for the call managers that support call bridging and allows two or more SCA users to be connected in a call with a third party.

Refer to the following example.

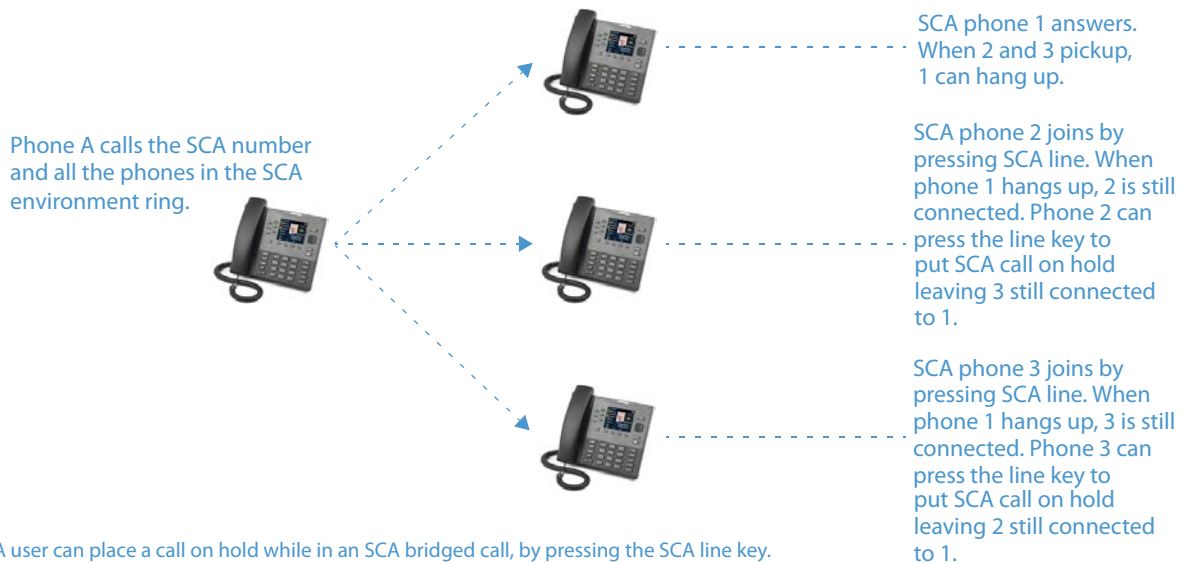

Using the example above, when a call comes into Phone 1, Phone 2 and Phone 3 can pickup the same call by pressing the SCA line key. Phone 2 and 3 display the call they are bridging into on the LCD of the phones. Existing SCA parties in a bridge or one-to-one call hear an audible beep when another party has joined the call.

### Note:

Your Administrator must enable/disable the beep on the server-side.

If a phone is configured for SCA bridging and it attempts to join a call, but the account on the server does not have this functionality enabled, an error message displays to the LCD on the phone.

The SCA call bridging feature is disabled by default on all phones. Your Administrator can enable/disable this feature if required. Contact your System Administrator for more information.

### Keys States and LED/Button Behavior

There are two call states on the phones that support SCA bridging:











- **Bridge-active** - A bridged call is in progress
- **Bridge-held** - The 3rd-party (i.e., non-SCA party) in the bridge is on hold.

The following tables provide the key states and LED/image behavior in an SCA bridge call for users involved in an SCA call (local) and users not involved in the SCA call (remote).

**Line Keys**

State	Line LED for Local	Line LED for Remote
Idle	Off	Off
Seized	Solid Green	Solid Red
Progressing (outgoing call)	Green	Solid Red
Alerting (incoming call)	Flashing Red	Off
Active	Solid Green	Solid Red
Held	Slow Flashing Green	Slow Flashing Red
Hold Private	Slow Flashing Green	Solid Red
Bridge-Active	Solid Green	Solid Red
Bridge-Held	Slow Flashing Green	Solid Red

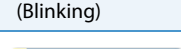
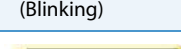
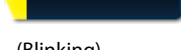
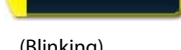
**Softkeys**

State	Softkey Image for Local	Softkey LED for Local	Softkey Image for Remote	Softkey LED for Remote
Idle		Off		Off
Seized		Solid Red		Solid Red
Progressing (outgoing call)		Solid Red		Solid Red
Alerting (incoming call)		Flashing Red		N/A
Active		Solid Red		Solid Red
Held	 (Blinking)	Slow Flashing Red	 (Blinking)	Slow Flashing Red
Hold Private	 (Blinking)	Slow Flashing Red	 (Blinking)	Solid Red
Bridge-Active		Solid Red		Solid Red
Bridge-Held	 (Blinking)	Slow Flashing Red	 (Blinking)	Solid Red

**Star Codes**

All of the main call handling and extension management features using star codes can be set on your phone by your Administrator. Contact your System Administrator for more information.

If these have not been set up, you can dial any star code commands on the 6867i phone the same way you would on a regular telephone.

**Other Features**

A multitude of other features are available depending on whether or not your System Administrator has configured them for use. Contact your System Administrator for feature availability and usage information.



# Model M680i Expansion Module

The 6867i IP phone offers an optional M680i Expansion Module that attaches to the right side of the phone to provide additional programmable keys.

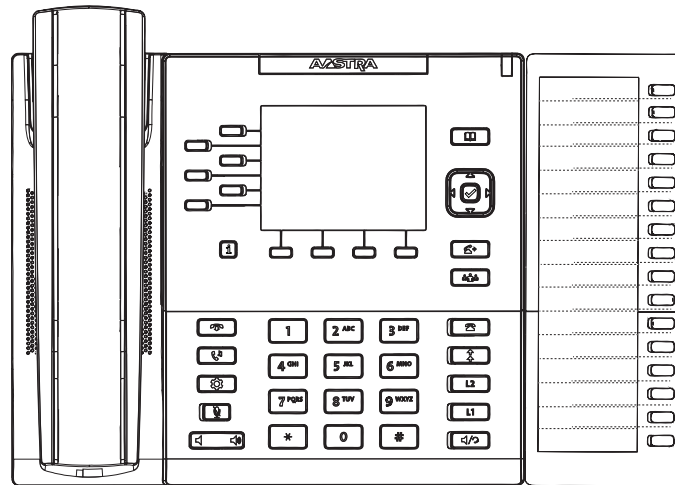

The M680i provides 16 softkeys on the dialpad. Each key provides an LED for indicating call status. The M680i provides a paper label for convenient key labelling.

The M680i Expansion Module keys support the following functions:

- None
- Line
- Speed Dial
- Do Not Disturb (DND)
- Busy Lamp Field (BLF)
- BLF/List
- Auto Call Distribution (ACD)
- Extensible Markup Language (XML)
- Flash
- Sprecode
- Park
- Pickup
- Last Call Return
- Call Forward
- BLF/Xfer
- Speed Dial/Xfer
- Speed Dial/Conf
- Directory
- Callers List
- Redial
- Conference
- Transfer
- Intercom (Icom)
- Phone Lock
- Paging
- Empty

You can configure the keys using the Aastra Web UI at the path, *Operation > Expansion Module <N>* when an Expansion Module is attached to the 6867i IP phone.

## Note:

For more information about configuring the expansion module keys with these functions, see the [“Configuring Softkeys”](#) on page 57.

## Using the Expansion Modules

### M680i Expansion Module

After configuring the softkeys on the M680i Expansion Module, you can record the name of the key on the paper labels provided with the Expansion Module. Press the key you want to use when applicable.

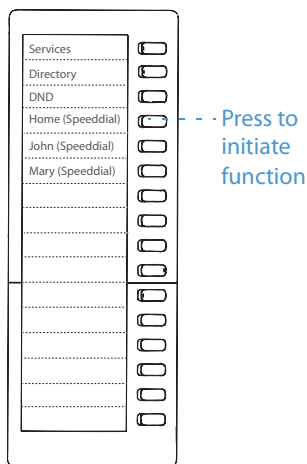

**Note:**

For more information about installing the M680i Expansion Modules on your phone, see the ***Aastra M680i Expansion Module Quick Start Guide*** and ***Aastra M680i Expansion Module Installation Guide***.

### Press-and-Hold to Create a Speed Dial Key



You can press and hold an expansion module key to create a speed dial key and configure it the same way you configure a speed dial key on the phone. For details on creating a speed dial key, see “Speed Dial Key” on page 62.

# Troubleshooting Solutions

## *Why is my display blank?*

Ensure that power is being provided to your phone. If your network does not provide inline power over Ethernet, you can obtain an additional accessory, the Aastra PoE (Power over Ethernet) inline power supply, to provide power over Ethernet locally to your phone. See the **Connecting to the Network and to Power** section in the **Aastra 6867i Installation Guide** for details.

## *Why is my speakerphone not working?*

If you press the  button and the speaker light flashes and you do not hear dial tone through the speaker, the **Audio Mode** option in the phone has been set up for headset use. Press  a second time and if the light goes out, the phone has been set up to be used only with a headset or handset. If the light stays on steady and you hear a dial tone, the phone has been set up so that you can alternate between the speakerphone and the headset by pressing . See **"Audio Mode"** on [page 45](#) for instructions on how to change the **Audio Mode** option.

## *Why can't I get a dial tone?*

Check for any loose connections and that the phone has been installed properly. For installation instructions, please refer to the **Installation and Setup** section in the **Aastra 6867i Installation Guide**.

## *Why doesn't my phone ring?*

Check the ring volume on your phone. It may be turned down or turned off. To adjust the ringer volume setting, press the volume button when the phone is on-hook and idle.

## *Why is the light not coming on with a new voicemail message?*

Your phone system or service provider must provide the visual message waiting service for this function to work. Check with your System Administrator for more information.

## *Why is my handset not working?*

Check to ensure that the handset cord is fully connected to both the phone and handset. See the **Connecting a Handset or Headset** section in the **Aastra 6867i Installation Guide** for information.

## *How do I find the IP address of my phone?*

Instructions on where to find the IP address of your phone can be found in **"Finding Your Phone's IP Address"** on [page 25](#).

## *Why does my phone display the No Service message?*

The phone displays the **No Service** message if the SIP settings have not been set up correctly. Contact your System Administrator for more information.

## *How do I change my user password?*

You can change the user password from the IP phone UI or the Aastra Web UI. See **"Password"** on [page 40](#) and **"Configuring Lock Settings Using the Aastra Web UI"** on [page 42](#) for more information.

## *Why does my phone display Bad Encrypted Config?*

The IP phone displays **Bad Encrypted Config** because encrypted configuration files are enabled but the decryption process has failed. Report this error to your System Administrator.

### ***How do I restart the IP phone?***

You can restart the phone from the IP phone UI or through the Aastra Web UI. See [“Restarting Your Phone Using the IP Phone UI”](#) on [page 53](#) and [“Restarting Your Phone Using the Aastra Web UI”](#) on [page 53](#) for more information.

### ***How do I lock my phone?***

You can lock your phone to prevent the phone from being used or configured. You can lock the phone using any of the following:

- At the path *Options > Phone Lock* on the IP phone UI. See [“Phone Lock”](#) on [page 40](#) for more information.
- At the path *Operations > Phone Lock* on the Aastra Web UI. See [“Configuring Lock Settings Using the Aastra Web UI”](#) on [page 42](#) for more information.
- At a configured key on the phone. For more information about configuring a Lock/Unlock key on your phone, see [“Paging Key”](#) on [page 98](#).

# Limited Warranty

## (Not applicable in Australia – see below for Limited Warranty in Australia)

Aastra warrants this product against defects and malfunctions in accordance with Aastra's authorized, written functional specification relating to such products during a one (1) year period from the date of original purchase ("Warranty Period"). If there is a defect or malfunction, Aastra shall, at its option, and as the exclusive remedy, either repair or replace the product at no charge, if returned within the Warranty Period. If replacement parts are used in making repairs, these parts may be refurbished, or may contain refurbished materials. If it is necessary to replace the product, it may be replaced with a refurbished product of the same design and color. If it should become necessary to repair or replace a defective or malfunctioning product under this warranty, the provisions of this warranty shall apply to the repaired or replaced product until the expiration of ninety (90) days from the date of pick up, or the date of shipment to you, of the repaired or replacement product, or until the end of the original Warranty Period, whichever is later. Proof of the original purchase date is to be provided with all products returned for warranty repairs.

## Exclusions

Aastra does not warrant its products to be compatible with the equipment of any particular telephone company. This warranty does not extend to damage to products resulting from improper installation or operation, alteration, accident, neglect, abuse, misuse, fire or natural causes such as storms or floods, after the product is in your possession. Aastra will not accept liability for any damages and/or long distance charges, which result from unauthorized and/or unlawful use.

Aastra shall not be liable for any incidental or consequential damages, including, but not limited to, loss, damage or expense directly or indirectly arising from the customer's use of or inability to use this product, either separately or in combination with other equipment. This paragraph, however, shall not apply to consequential damages for injury to the person in the case of products used or bought for use primarily for personal, family or household purposes.

This warranty sets forth the entire liability and obligations of Aastra with respect to breach of warranty, and the warranties set forth or limited herein are the sole warranties and are in lieu of all other warranties, expressed or implied, including warranties or fitness for particular purpose and merchantability.

## Warranty Repair Services

Should the product fail during the Warranty Period;

- **In North America**, please call 1-800-574-1611 for further information.
- **Outside North America**, contact your sales representative for return instructions.

You will be responsible for shipping charges, if any. When you return this product for warranty service, you must present proof of purchase.

## After Warranty Service

Aastra offers ongoing repair and support for this product. This service provides repair or replacement of your Aastra product, at Aastra's option, for a fixed charge. You are responsible for all shipping charges. For further information and shipping instructions:

- **In North America**, contact our service information number: 1-800-574-1611.
- **Outside North America**, contact your sales representative.

### Note:

Repairs to this product may be made only by the manufacturer and its authorized agents, or by others who are legally authorized. This restriction applies during and after the Warranty Period. Unauthorized repair will void the warranty.

# Limited Warranty (Australia Only)

The benefits under the Aastra Limited Warranty below are in addition to other rights and remedies to which you may be entitled under a law in relation to the products.

In addition to all rights and remedies to which you may be entitled under the *Competition and Consumer Act 2010* (Commonwealth) and any other relevant legislation, Aastra warrants this product against defects and malfunctions in accordance with Aastra's authorized, written functional specification relating to such products during a one (1) year period from the date of original purchase ("Warranty Period"). If there is a defect or malfunction, Aastra shall, at its option, and as the exclusive remedy under this limited warranty, either repair or replace the product at no charge, if returned within the Warranty Period.

## Repair Notice

To the extent that the product contains user-generated data, you should be aware that repair of the goods may result in loss of the data. Goods presented for repair may be replaced by refurbished goods of the same type rather than being repaired. Refurbished parts may be used to repair the goods. If it is necessary to replace the product under this limited warranty, it may be replaced with a refurbished product of the same design and color.

If it should become necessary to repair or replace a defective or malfunctioning product under this warranty, the provisions of this warranty shall apply to the repaired or replaced product until the expiration of ninety (90) days from the date of pick up, or the date of shipment to you, of the repaired or replacement product, or until the end of the original Warranty Period, whichever is later. Proof of the original purchase date is to be provided with all products returned for warranty repairs.

## Exclusions

Aastra does not warrant its products to be compatible with the equipment of any particular telephone company. This warranty does not extend to damage to products resulting from improper installation or operation, alteration, accident, neglect, abuse, misuse, fire or natural causes such as storms or floods, after the product is in your possession. Aastra will not accept liability for any damages and/or long distance charges, which result from unauthorized and/or unlawful use.

To the extent permitted by law, Aastra shall not be liable for any incidental damages, including, but not limited to, loss, damage or expense directly or indirectly arising from your use of or inability to use this product, either separately or in combination with other equipment. This paragraph, however, is not intended to have the effect of excluding, restricting or modifying the application of all or any of the provisions of Part 5-4 of Schedule 2 to the Competition and Consumer Act 2010 (**the ACL**), the exercise of a right conferred by such a provision or any liability of Aastra in relation to a failure to comply with a guarantee that applies under Division 1 of Part 3-2 of the ACL to a supply of goods or services.

This express warranty sets forth the entire liability and obligations of Aastra with respect to breach of this express warranty and is in lieu of all other express or implied warranties other than those conferred by a law whose application cannot be excluded, restricted or modified. Our goods come with guarantees that cannot be excluded under the Australian Consumer Law. You are entitled to a replacement or refund for a major failure and for compensation for any other reasonably foreseeable loss or damage. You are also entitled to have the goods repaired or replaced if the goods fail to be of acceptable quality and the failure does not amount to a major failure.

## Warranty Repair Services

**Procedure: Should the product fail during the Warranty Period and you wish to make a claim under this express warranty, please contact the Aastra authorized reseller who sold you this product (details as per the invoice) and present proof of purchase. You will be responsible for shipping charges, if any.**

Manufacturer: Aastra Telecom Australia Pty Ltd  
745 Springvale Road  
Mulgrave VIC 3170  
ABN 16 140 787 195  
Phone: +61 3 8562 2700

### **Limitation of Liability for Products not of a kind ordinarily acquired for personal, domestic or household use or consumption (e.g. goods/services ordinarily supplied for business-use)**

- 1.1** To the extent permitted by law and subject to clause 1.2 below, the liability of Aastra to you for any non-compliance with a statutory guarantee or loss or damage arising out of or in connection with the supply of goods or services (whether for tort (including negligence), statute, custom, law or on any other basis) is limited to:
- a)** in the case of services:
    - i)** the resupply of the services; or
    - ii)** the payment of the cost of resupply; and
  - b)** in the case of goods:
    - i)** the replacement of the goods or the supply of equivalent goods; or
    - ii)** the repair of the goods; or
    - iii)** the payment of the cost of replacing the goods or of acquiring equivalent goods; or
    - iv)** the payment of the cost of having the goods repaired.
- 1.2** Clause 1.1 is not intended to have the effect of excluding, restricting or modifying:
- a)** the application of all or any of the provisions of Part 5-4 of Schedule 2 to the Competition and Consumer Act 2010 (**the ACL**); or
  - b)** the exercise of a right conferred by such a provision; or
  - c)** any liability of Aastra in relation to a failure to comply with a guarantee that applies under Division 1 of Part 3-2 of the ACL to a supply of goods or services.

## After Warranty Service

Aastra offers ongoing repair and support for this product. If you are not otherwise entitled to a remedy for a failure to comply with a guarantee that cannot be excluded under the Australian Consumer Law, this service provides repair or replacement of your Aastra product, at Aastra's option, for a fixed charge. You are responsible for all shipping charges. For further information and shipping instructions contact:

Aastra Telecom Australia Pty Ltd  
745 Springvale Road  
Mulgrave VIC 3170  
ABN 16 140 787 195  
Phone: +61 3 8562 2700

### **Note:**

Repairs to this product may be made only by the manufacturer and its authorized agents, or by others who are legally authorized. Unauthorized repair will void this express warranty.

# Appendix A - Time Zone Codes

The following table identifies the time zone name and time zone code to use on the IP phone.

**Time Zone Name/Time Zone Code Table**

Time Zone Name	Time Zone Code
AD-Andorra	CET
AE-Dubai	GST
AG-Antigua	AST
AI-Anguilla	AST
AL-Tirane	CET
AN-Curacao	AST
AR-Buenos Aires	ART
AS-Pago Pago	BST
AT-Vienna	CET
AU-Lord Howe	LHS
AU-Tasmania	EST
AU-Melbourne	EST
AU-Sydney	EST
AU-Broken Hill	CST
AU-Brisbane	EST
AU-Lindeman	EST
AU-Adelaide	CST
AU-Darwin	CST
AU-Perth	WST
AW-Aruba	AST
AZ-Baku	AZT
BA-Sarajevo	EET
BB-Barbados	AST
BE-Brussels	CET
BG-Sofia	EET
BM-Bermuda	AST
BO-La Paz	BOT
BR-Noronha	FNT
BR-Belem	BRT
BR-Fortaleza	BRT
BR-Recife	BRT
BR-Araguaina	BRS
BR-Maceio	BRT
BR-Sao Paulo	BRS
BR-Cuiaba	AMS
BR-Porto Velho	AMT
BR-Boa Vista	AMT
BR-Manaus	AMT
BR-Eirunepe	ACT
BR-Rio Branco	ACT
BS-Nassau	EST
BY-Minsk	EET
BZ-Belize	CST



Time Zone Name	Time Zone Code
CA-Newfoundland	NST
CA-Atlantic	AST
CA-Eastern	EST
CA-Saskatchewan	EST
CA-Central	CST
CA-Mountain	MST
CA-Pacific	PST
CA-Yukon	PST
CH-Zurich	CET
CK-Rarotonga	CKS
CL-Santiago	CLS
CL-Easter	EAS
CN-Beijing	CST
CO-Bogota	COS
CR-Costa Rica	CST
CU-Havana	CST
CY-Nicosia	EES
CZ-Prague	CET
DE-Berlin	CET
DK-Copenhagen	CET
DM-Dominica	AST
DO-Santo Domingo	AST
EE-Tallinn	EET
ES-Madrid	CET
ES-Canary	WET
FI-Helsinki	EET
FJ-Fiji	NZT
FK-Stanley	FKS
FO-Faeroe	WET
FR-Paris	CET
GB-London	GMT
GB-Belfast	GMT
GD-Grenada	AST
GE-Tbilisi	GET
GF-Cayenne	GFT
GI-Gibraltar	CET
GP-Guadeloupe	AST
GR-Athens	EET
GS-South Georgia	GST
GT-Guatemala	CST
GU-Guam	CST
GY-Guyana	GYT
HK-Hong Kong	HKS
HN-Tegucigalpa	CST
HR-Zagreb	CET
HT-Port-au-Prince	EST
HU-Budapest	CET
IE-Dublin	GMT
IS-Reykjavik	GMT
IT-Rome	CET
JM-Jamaica	EST
JP-Tokyo	JST
KY-Cayman	EST

Time Zone Name	Time Zone Code
LC-St Lucia	AST
LI-Vaduz	CET
LT-Vilnius	EET
LU-Luxembourg	CET
LV-Riga	EET
MC-Monaco	CET
MD-Chisinau	EET
MK-Skopje	CET
MQ-Martinique	AST
MS-Montserrat	AST
MT-Malta	CET
MU-Mauritius	MUT
MX-Mexico City	CST
MX-Cancun	CST
MX-Merida	CST
MX-Monterrey	CST
MX-Mazatlan	MST
MX-Chihuahua	MST
MX-Hermosillo	MST
MX-Tijuana	PST
NI-Managua	CST
NL-Amsterdam	CET
NO-Oslo	CET
NR-Nauru	NRT
NU-Niue	NUT
NZ-Auckland	NZS
NZ-Chatham	CHA
OM-Muscat	GST
PA-Panama	EST
PE-Lima	PES
PL-Warsaw	CET
PR-Puerto Rico	AST
PT-Lisbon	WET
PT-Madeira	WET
PT-Azores	AZO
PY-Asuncion	PYS
RO-Bucharest	EET
RU-Kaliningrad	EET
RU-Moscow	MSK
RU-Samara	SAM
RU-Yekaterinburg	YEK
RU-Omsk	OMS
RU-Novosibirsk	NOV
RU-Krasnoyarsk	KRA
RU-Irkutsk	IRK
RU-Yakutsk	YAK
RU-Vladivostok	VLA
RU-Sakhalin	SAK
RU-Magadan	MAG
RU-Kamchatka	PET
RU-Anadyr	ANA
SE-Stockholm	CET
SG-Singapore	SGT
SI-Ljubljana	CET
SK-Bratislava	CET
SM-San Marino	CET
SR-Paramaribo	SRT
SV-El Salvador	CST

Time Zone Name	Time Zone Code
TR-Istanbul	EET
TT-Port of Spain	AST
TW-Taipei	CST
UA-Kiev	EET
US-Eastern	EST
US-Central	CST
US-Mountain	MST
US-Pacific	PST
US-Alaska	AKS
US-Aleutian	HAS
US-Hawaii	HST
UY-Montevideo	UYS
VA-Vatican	CET
YU-Belgrade	CET

# Index

## Numerics

6867i	
additional features of	147
features of	1
line settings	55
making calls	102
requirements of	2

## A

Aastra Web UI	
Basic Settings parameters	22
Operaton parameters	21
phone status	21
about this guide	1
ACD key	71
allow barge-in, for intercom	158
answering incoming calls	109
audio mode	45
auto-answer, for intercom	158

## B

bad encrypted config	165
BLF key	68
BLF List, setting softkey for	69
BLF, setting softkey for	68
BLF/Xfer	82
BLF/Xfer key	82
BLF/Xfer, softkeys for	83, 84, 86

## C

Call Forward key	81
call forwarding, softkeys for	81
call hold reminder	154
call hold reminder during active calls	153
call waiting tone	148
call waiting tone period	155
callers list	130
deleting entries in	133
downloading to phone	129, 136
editing	132
storage	24
using	131
Callers List key	90, 92, 94, 95
callers list, softkey for	91, 93, 94, 95
calls	
conferencing	116
ending	121
receiving	109
transferring	111
conference key	5
conferencing	
centralized	120
ending	121
joining two active calls	119
local	116
transfer remaining parties	121

## D

deleting a key	101
----------------	-----

Detailed-View Call screen	13
dial plan, emergency	54
dial tones, stuttered	149
dialing a number	102
dialing screen	11
dialing, pre-dialing a number	102
dialpad, live	52
Directory key	4, 88
directory key, softkey for	89
directory list	122
adding and editing entries	124
downloading to PC	129
limitations for	125
storage	24
DND key	67
DND, enabling/disabling	137, 141
documentation	1
DTMF digits, displaying	147

## E

emergency dial plan, defining	54
Empty key	100
empty key, softkey for	100
expansion module, M680i	163

## F

Flash key	76
-----------	----

## G

getting started	7
goodbye key	4
Goodbye key cancels incoming call	156
group RTP paging	160

## H

handling calls	110
headset	46
headset mic	103
headset mode	45
headset, using	103
headset/speaker mode	45
held calls, retrieving	111
hold key	4
hold, automatic	111
Home screen	10
Home screen, indicators and messages	10

## I

Indication of transferred calls	115
installation and setup	2
intercom calls, incoming call features	158
Intercom key, softkey for	96
Intercom, using	104
IP address, finding	25, 26, 165

## K

keys	
ACD key	71
BLF key	68
BLF List key	69

- BLF/Xfer key ..... 82
  - Call Forward key ..... 81
  - callers list ..... 4, 90, 92
  - Callers List key ..... 94, 95
  - conference ..... 5
  - deleting ..... 101
  - description ..... 4
  - dialpad ..... 6
  - directory ..... 4
  - Directory key ..... 88
  - DND key ..... 67
  - Empty key ..... 100
  - Flash key ..... 76
  - goodbye ..... 4
  - hold ..... 4
  - Intercom key ..... 96
  - Last Call Return (lcr) ..... 80
  - line ..... 4
  - Line key ..... 61
  - mute ..... 4
  - navigation ..... 4
  - options ..... 4
  - Paging key ..... 98
  - Park and Pickup keys ..... 78
  - Phone Lock key ..... 97
  - presence ..... 5, 56
  - redial ..... 4
  - speaker ..... 4
  - Speed Dial/Conf key ..... 86
  - Speed Dial/Xfer key ..... 84
  - Sprecode key ..... 77
  - transfer ..... 4
  - volume control ..... 4
  - XML key ..... 74
- L**
- language
    - latin 2 character set ..... 34
    - overview ..... 28
    - specifying on IP phone ..... 28, 29
  - last call return, softkeys for ..... 80
  - LCR key ..... 80
  - Line key ..... 61
  - line keys ..... 4
  - Line Selection screen ..... 12
  - line, setting a softkey for ..... 61
  - lock ..... 40
  - lock/unlock the phone ..... 40, 166
- M**
- making calls ..... 102
  - managing calls ..... 122
  - message waiting indicator, configuring ..... 157
  - microphone mute, for intercom ..... 158
  - microphone volume, headset ..... 46
  - missed calls indicator
    - accessing and clearing ..... 135
    - overview ..... 135
  - Multi-View Call screen ..... 14
  - mute key ..... 4
- N**
- navigation keys ..... 4
  - network disconnected ..... 9
  - no service ..... 165
- O**
- on-hold calls ..... 110
  - options
    - setting via the phone UI ..... 17
    - setting via the Web UI ..... 20
  - options key ..... 4
- P**
- Paging key ..... 98
  - paging, softkeys for ..... 98
  - Park key ..... 78
  - park/pickup, using on the IP phone ..... 79
  - password ..... 40
  - password, resetting user's ..... 43
  - phone lock ..... 40
  - Phone Lock key ..... 97
  - plugging in the phone ..... 7
  - presence key ..... 5, 56
  - presence key, using ..... 56
- R**
- redial key ..... 4
  - redial list storage ..... 24
  - RTP paging, group ..... 160
- S**
- softkey, more ..... 12
  - softkeys ..... 57
  - Software License Agreement ..... ii
  - speaker key ..... 4
  - speaker mode ..... 45
  - speaker/headset mode ..... 45
  - speed dial
    - assigning as softkey or programmable key ..... 62
    - creating from Dialpad Speed Dial in Web UI ..... 66
    - creating using function keys ..... 65
    - creating using Speed Dial Edit ..... 64
    - prefix ..... 62
    - press-and-hold ..... 63
  - Speed Dial key ..... 62
  - speed dial/Xfer ..... 84
  - Speed Dial/Xfer key ..... 84
  - Sprecode key ..... 77
  - sprecode, setting key for ..... 77
  - star codes ..... 162
  - starting up the phone ..... 7
  - status scroll delay ..... 151
  - storage
    - callers list ..... 24
    - directory ..... 24
    - redial list ..... 24
  - switch UI focus to ringing line ..... 152
- T**
- time and date ..... 35
  - time and date format ..... 35
  - transfer key ..... 4
  - transferring calls
    - blind ..... 111
    - consultative ..... 111
    - indication of ..... 115
  - troubleshooting solutions ..... 165
    - changing user password ..... 165
    - display blank ..... 165
    - finding IP address ..... 165

handset not working ..... 165  
locking/unlocking phone ..... 166  
no dial tone ..... 165  
no ring ..... 165  
no speakerphone ..... 165  
phone displays "Bad Encrypted Config" ..... 165  
phone displays "No Service" ..... 165  
restarting the phone ..... 166  
using services ..... 165  
VM message light not working ..... 165

**U**

UI, navigation ..... 15  
UI, overview ..... 10  
Using ..... 67

**V**

voicemail ..... 109  
volume control keys ..... 4

**W**

warning tone, for Intercom ..... 158  
warranty exclusions ..... 1  
Web UI, using ..... 20

**X**

XML beep support ..... 150  
XML key ..... 74  
XML services, accessing ..... 75



### **Disclaimer**

Aastra will not accept liability for any damages and/or long distance charges, which result from unauthorized and/or unlawful use. While every effort has been made to ensure accuracy, Aastra will not be liable for technical or editorial errors or omissions contained within this documentation. The information contained in this documentation is subject to change without notice.

Copyright © 2014 Mitel Networks Corporation, [www.aastra.com](http://www.aastra.com).



## Free Manuals Download Website

<http://myh66.com>

<http://usermanuals.us>

<http://www.somanuals.com>

<http://www.4manuals.cc>

<http://www.manual-lib.com>

<http://www.404manual.com>

<http://www.luxmanual.com>

<http://aubethermostatmanual.com>

Golf course search by state

<http://golfingnear.com>

Email search by domain

<http://emailbydomain.com>

Auto manuals search

<http://auto.somanuals.com>

TV manuals search

<http://tv.somanuals.com>