



ACCES I/O PRODUCTS INC
10623 Roselle Street, San Diego, CA 92121
TEL (619)550-9559 FAX (619)**550-7322**

MODEL AIM-16

USER MANUAL

FILE: MAIM-16.D1d

Notice

The information in this document is provided for reference only. ACCES does not assume any liability arising out of the application or use of the information or products described herein. This document may contain or reference information and products protected by copyrights or patents and does not convey any license under the patent rights of ACCES, nor the rights of others.

IBM PC, PC/XT, and PC/AT are registered trademarks of the International Business Machines Corporation.

Printed in USA. Copyright 1995 by ACCES I/O Products Inc, 10623 Roselle Street, San Diego, CA 92121. All rights reserved.

Warranty

Prior to shipment, ACCES equipment is thoroughly inspected and tested to applicable specifications. However, should equipment failure occur, ACCES assures its customers that prompt service and support will be available. All equipment originally manufactured by ACCES which is found to be defective will be repaired or replaced subject to the following considerations.

Terms and Conditions

If a unit is suspected of failure, contact ACCES' Customer Service department. Be prepared to give the unit model number, serial number, and a description of the failure symptom(s). We may suggest some simple tests to confirm the failure. We will assign a Return Material Authorization (RMA) number which must appear on the outer label of the return package. All units/components should be properly packed for handling and returned with freight prepaid to the ACCES designated Service Center, and will be returned to the customer's/user's site freight prepaid and invoiced.

Coverage

First Three Years: Returned unit/part will be repaired and/or replaced at ACCES option with no charge for labor or parts not excluded by warranty. Warranty commences with equipment shipment.

Following Years: Throughout your equipment's lifetime, ACCES stands ready to provide on-site or in-plant service at reasonable rates similar to those of other manufacturers in the industry.

Equipment Not Manufactured by ACCES

Equipment provided but not manufactured by ACCES is warranted and will be repaired according to the terms and conditions of the respective equipment manufacturer's warranty.

General

Under this Warranty, liability of ACCES is limited to replacing, repairing or issuing credit (at ACCES discretion) for any products which are proved to be defective during the warranty period. In no case is ACCES liable for consequential or special damage arising from use or misuse of our product. The customer is responsible for all charges caused by modifications or additions to ACCES equipment not approved in writing by ACCES or, if in ACCES opinion the equipment has been subjected to abnormal use. "Abnormal use" for purposes of this warranty is defined as any use to which the equipment is exposed other than that use specified or intended as evidenced by purchase or sales representation. Other than the above, no other warranty, expressed or implied, shall apply to any and all such equipment furnished or sold by ACCES.

Table of Contents

Notice	iii
Warranty	iv
Chapter 1: Introduction	1-1
Specifications	1-2
Chapter 2: Installation	2-1
CD Installation	2-1
3.5-Inch Diskette Installation	2-1
Directories Created on the Hard Disk	2-2
Installation of the AIM-16	2-4
Option Selection	2-7
Gain Selection	2-7
Channel Selection	2-9
Current Inputs	2-9
RTD Sensor Selection	2-10
Power Supply Selection	2-10
Calibration and Test	2-12
Chapter 3: Software	3-1
Drivers	3-1
Sample Programs	3-1
SETMUX	3-1
Chapter 4: Sensor Interface	4-1
Considerations for Thermocouples	4-1
Considerations for RTD Sensors	4-2
Considerations for Strain Gage Sensors	4-2
Considerations for Current Inputs	4-3
Considerations for Other Voltage Inputs	4-3
Appendix A: Cabling and Connector Information	A-1
Input Connector Pin Assignments	A-1

List of Figures

Figure 1-1: AIM-16 Block Diagram	1-3
Figure 2-1: Use of CAB-37Y Cables	2-6
Figure 2-2: AIM-16 Option Selection Map	2-11

List of Tables

Table 2-1: AIM-16 Gain Table	2-8
Table A-1: Connector Pin Assignments	A-2

Chapter 1: Introduction

Analog Input Multiplexer, Model AIM-16, is installed external to the computer. The AIM-16 accepts, preamplifies, and multiplexes up to 16 analog input signals before passing them to an analog-to-digital converter typically located in an I/O slot in a PC/XT/AT type host computer. This allows direct sensor interface without jeopardizing the quality of gathered data. The AIM-16 provides screw-terminal terminations and input signal conditioning for a variety of sensors including thermocouples (J,K,T,E,S,R, and B), three-wire RTDs (both for 392- and 385-alpha), and strain gages as well as DC voltage and current inputs. For strain gage applications, +10V at up to 220mA excitation voltage for the strain gages is provided by the ACCES Model AD12-8 analog-to-digital converter through the AIM-16. That excitation voltage is available at a 2-position screw-terminal block labeled REF OUT.

An input, when selected by the input multiplexer, is filtered, amplified, and, if required, level shifted. After this processing, the signal is supplied to an output channel where it is passed to the analog-to-digital converter. The A/D converter digitizes the DC signal and presents it to the computer CPU for further processing and/or display.

A major feature of this card is that it can be used with mixed-range analog inputs. The AIM-16 provides extensive programming flexibility for both hardware and software configuration. Four digital input lines are used for channel selection and three digital input lines are used for gain selection. Gains may be selected by software or manually by switch. When selected manually, the gain setting chosen applies to all input channels.

Software included with model AD12-8 analog-to-digital converter facilitates interface to the AIM-16. That software includes setup programs, drivers, and sample programs. Read sections Installation and Software for more details.

The AIM-16 card may be used as part of a large data acquisition system. A system may comprise one to eight of these cards, all interconnected on the same output bus because each card has two parallel input/output connectors. For thermocouple measurements, each card may provide it's own reference junction compensation at input IN0 by using jumpers marked "TMP" as described in Installation. Also, for thermocouple applications, a break-detect circuit is activated by installation of a pair of shorts for each thermocouple input channel.

Option P consists of a DC-DC converter which operates from the +5VDC computer power supply and provides isolated ± 15 VDC for use by the analog circuits on AIM-16. This option is particularly useful if the ± 12 VDC computer power is noisy and/or is marginally low.

Model AIM-16I has current-sensing resistors installed for use in 4-20mA applications. Further, it has also been modified so that maximum resolution is provided at the A/D converter. The modifications that are made include introduction of an offset and addition of a gain adjustment pot, so that full 12-bit resolution is provided. Model AIM-16R is specifically modified to provide the best possible accuracy for RTD inputs.

Specifications

Analog Inputs and Outputs

- Input Channels: 16 Differential Analog Input Channels per AIM-16.
- Output Channels: Analog Output assignable to 1 of 8 Output Channels.
- Common Mode Rejection: 125 db for gains above 100.
90 db for gain = 1.
- Output Rating: 5mA at $\pm 10\text{VDC}$ or $\pm 5\text{VDC}$.
- Gain Nonlinearity: $\pm 0.005\%$.
- Temp. Coefficient: 5 ppm/ $^{\circ}\text{C}$.
- Overvoltage: Continuous: 70V peak-to-peak, 35VDC.
- Sensors: Thermocouples, with break detect provided.
- RTDs, with excitation and offset provided.
- Strain gages, with ratiometric outputs.
- Voltage and current inputs.
- Reference Junction: Temperature Scale Factor: $+24.4\text{mV}/^{\circ}\text{C}$., 0.0VDC @ 0°C .
Reference junction temperature output assignable as an input to Analog Input Channel #0, or to any Output Channel.
- Preamplifier: 12 Analog Gains ranging from 0.5 to 1000.
- Programmable gains selected by computer, channel by channel.
- Manual gains selected by DIP switch one gain setting for all channels.
- Three TTL digital inputs for gain selection.
- Control Inputs: Four TTL digital inputs for channel selection.
- Terminations: Analog inputs: Plug-on screw terminal blocks for 12-22 AWG wire.
- Digital Input/Analog Output: 37-pin Sub-D connector.

Environmental

- Operating Temp: 0°C . to 65°C .
- Storage Temp: -40°C . to $+100^{\circ}\text{C}$.
- Humidity: 0 to 90% RH non-condensing.
- Size: 8.0 inches long, 4.75 inches wide, 0.75 inches high.
- Power Required: +5VDC: 20mA typical, with option P, DC to DC converter,
+5VDC: 125mA max..
+12VDC: 10mA typical.
-12VDC: 10mA typical.

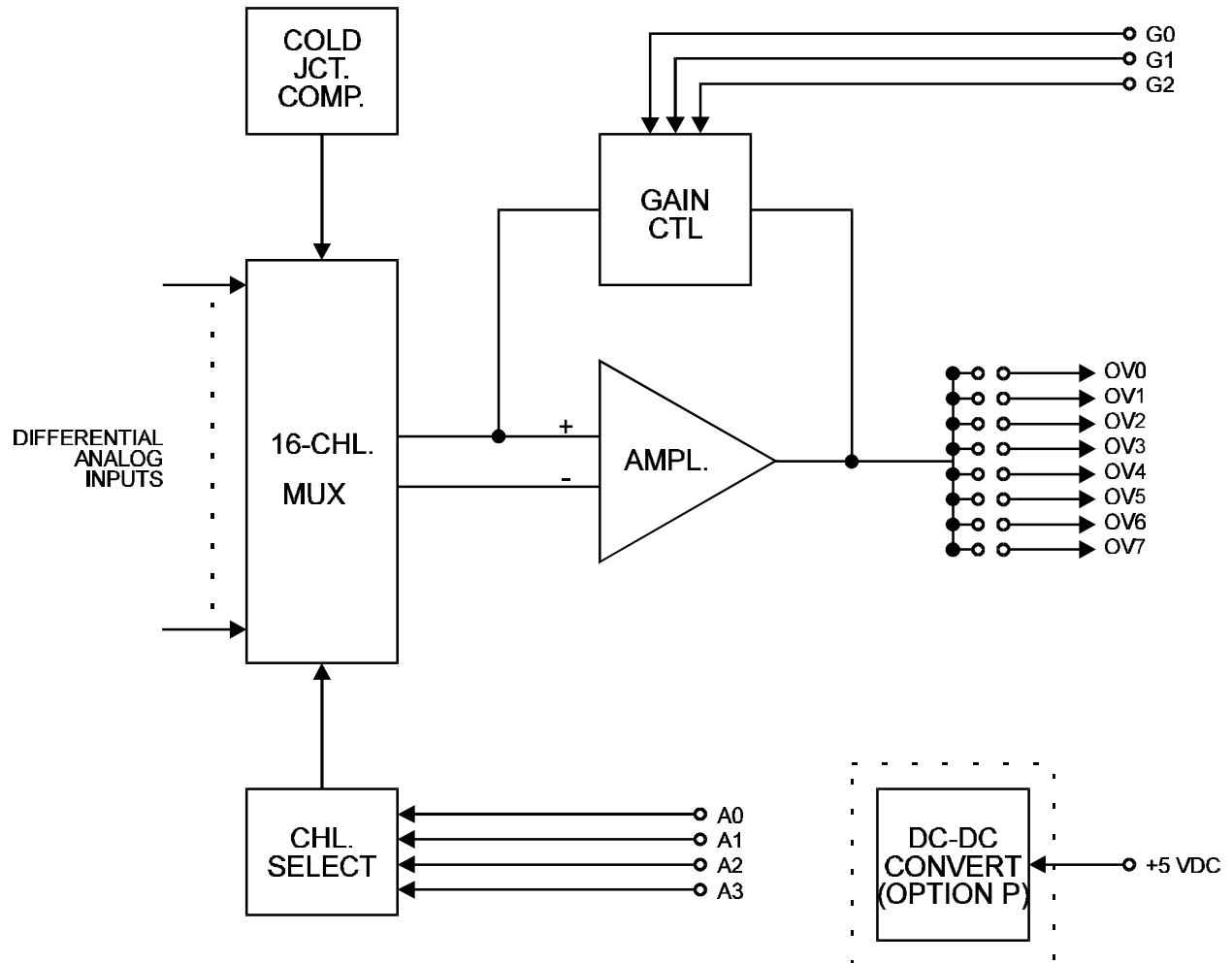

Figure 1-1: AIM-16 Block Diagram

AIM-16 Manual

Chapter 2: Installation

The software provided with this card is contained on either one CD or multiple diskettes and must be installed onto your hard disk prior to use. To do this, perform the following steps as appropriate for your software format and operating system. Substitute the appropriate drive letter for your CD-ROM or disk drive where you see d: or a: respectively in the examples below.

CD Installation

DOS/WIN3.x

- a. Place the CD into your CD-ROM drive.
- b. Type d:K to change the active drive to the CD-ROM drive.
- c. Type installK to run the install program.
- d. Follow the on-screen prompts to install the software for this card.

WIN95/98/NT

- a. Place the CD into your CD-ROM drive.
- b. The CD should automatically run the install program after 30 seconds. If the install program does not run, click START | RUN and type d:install, click OK or press K.
- c. Follow the on-screen prompts to install the software for this card.

3.5-Inch Diskette Installation

As with any software package, you should make backup copies for everyday use and store your original master diskettes in a safe location. The easiest way to make a backup copy is to use the DOS DISKCOPY utility.

In a single-drive system, the command is:

```
diskcopy a: a:K
```

You will need to swap disks as requested by the system.

In a two-disk system, the command is:

```
diskcopy a: b:K
```

This will copy the contents of the master disk in drive A to the backup disk in drive B.

To copy the files on the master diskette to your hard disk, perform the following steps.

- a. Place the master diskette into a floppy drive.
- b. Change the active drive to the drive that has the diskette installed. For example, if the diskette is in drive A, type a:K.
- c. Type `installK` and follow the on-screen prompts.

Directories Created on the Hard Disk

The installation process will create several directories on your hard disk. If you accept the installation defaults, the following structure will exist.

[CARDNAME]

Root or base directory containing the `SETUP.EXE` setup program used to help you configure jumpers and calibrate the card.

DOS\PSAMPLES: A subdirectory of [CARDNAME] that contains Pascal samples.

DOS\CSAMPLES: A subdirectory of [CARDNAME] that contains "C" samples.

Win32\language: Subdirectories containing samples for Win95/98 and NT.

WinRisc.exe

A Windows dumb-terminal type communication program designed for RS422/485 operation. Used primarily with Remote Data Acquisition Pods and our RS422/485 serial communication product line. Can be used to say hello to an installed modem.

ACCES32

This directory contains the Windows 95/98/NT driver used to provide access to the hardware registers when writing 32-bit Windows software. Several samples are provided in a variety of languages to demonstrate how to use this driver. The DLL provides four functions (`InPortB`, `OutPortB`, `InPort`, and `OutPort`) to access the hardware.

This directory also contains the device driver for Windows NT, `ACCESNT.SYS`. This device driver provides register-level hardware access in Windows NT. Two methods of using the driver are available, through `ACCES32.DLL` (recommended) and through the `DeviceIOControl` handles provided by `ACCESNT.SYS` (slightly faster).

SAMPLES

Samples for using ACCES32.DLL are provided in this directory. Using this DLL not only makes the hardware programming easier (MUCH easier), but also one source file can be used for both Windows 95/98 and WindowsNT. One executable can run under both operating systems and still have full access to the hardware registers. The DLL is used exactly like any other DLL, so it is compatible with any language capable of using 32-bit DLLs. Consult the manuals provided with your language's compiler for information on using DLLs in your specific environment.

VBACCES

This directory contains sixteen-bit DLL drivers for use with VisualBASIC 3.0 and Windows 3.1 only. These drivers provide four functions, similar to the ACCES32.DLL. However, this DLL is only compatible with 16-bit executables. Migration from 16-bit to 32-bit is simplified because of the similarity between VBACCES and ACCES32.

PCI

This directory contains PCI-bus specific programs and information. If you are not using a PCI card, this directory will not be installed.

SOURCE

A utility program is provided with source code you can use to determine allocated resources at run-time from your own programs in DOS.

PCIFind.exe

A utility for DOS and Windows to determine what base addresses and IRQs are allocated to installed PCI cards. This program runs two versions, depending on the operating system. Windows 95/98/NT displays a GUI interface, and modifies the registry. When run from DOS or Windows3.x, a text interface is used. For information about the format of the registry key, consult the card-specific samples provided with the hardware. In Windows NT, NTioPCI.SYS runs each time the computer is booted, thereby refreshing the registry as PCI hardware is added or removed. In Windows 95/98/NT PCIFind.EXE places itself in the boot-sequence of the OS to refresh the registry on each power-up.

This program also provides some COM configuration when used with PCI COM ports. Specifically, it will configure compatible COM cards for IRQ sharing and multiple port issues.

WIN32IRQ

This directory provides a generic interface for IRQ handling in Windows 95/98/NT. Source code is provided for the driver, greatly simplifying the creation of custom drivers for specific needs. Samples are provided to demonstrate the use of the generic driver. Note that the use of IRQs in near-real-time data acquisition programs requires multi-threaded application programming techniques and must be considered an intermediate to advanced programming topic. Delphi, C++ Builder, and Visual C++ samples are provided.

Findbase.exe

DOS utility to determine an available base address for ISA bus , non-Plug-n-Play cards. Run this program once, before the hardware is installed in the computer, to determine an available address to give the card. Once the address has been determined, run the setup program provided with the hardware to see instructions on setting the address switch and various option selections.

Poly.exe

A generic utility to convert a table of data into an nth order polynomial. Useful for calculating linearization polynomial coefficients for thermocouples and other non-linear sensors.

Risc.bat

A batch file demonstrating the command line parameters of RISCTerm.exe.

RISCTerm.exe

A dumb-terminal type communication program designed for RS422/485 operation. Used primarily with Remote Data Acquisition Pods and our RS422/485 serial communication product line. Can be used to say hello to an installed modem. RISCTerm stands for Really Incredibly Simple Communications TERMinal.

Installation of the AIM-16

The AIM-16 is installed external to the host computer. It provides screw-terminal termination for input analog wiring, and multiplexing and preamplification for input signals. Multiplexed and amplified signals are then passed from the AIM-16 to an analog-to-digital converter via a 37-conductor ribbon cable.

The screw-terminal blocks used to connect analog input wires can be removed from the card to facilitate wire installation. After the wiring has been installed, the terminal blocks can then be plugged back onto the card. Inputs to the AIM-16 are labelled IN0 through IN15. Note that, for thermocouple temperature measurements, IN0 may be used as the input channel for the on-board reference junction sensor, so that reference junction compensation may be accomplished

Note

No input may be connected to IN0 when the TMP jumpers are installed.

Input connections are labeled "+", "GND", and "-". Shields should be connected to the "GND" terminal if not grounded at the sensor end. Three-wire RTD connections can be made as follows: connect RTD wires +V and +I to the "+" terminal on the AIM-16, connect RTD wire -V to the "-" terminal, and connect RTD wire -I to the "GND" terminal. To assure that there is minimum susceptibility to EMI, proper EMI cabling techniques (twisted-pair wiring and, in extreme cases shielded wiring) must be used on input wiring.

If the precision 10V reference voltage from the A/D converter is to be used by external circuits, make connections to the two-position screw terminal labeled REF OUT. Then, connect a cable between the 37-pin connector on the card and the A/D converter.

As many as eight AIM-16 cards, or 128 channels may be serviced by one analog-to-digital converter card. The AIM-16 cards in the system are "daisy-chained" together by 37-conductor ribbon cables plugged on each card to two parallel 37-pin Sub-D connectors. The address of the AIM-16 card is established by selecting an output channel via a jumper installed at location OV0 to OV7.

The ribbon cable that interconnects AIM-16 to the AD12-8 also provides computer power (via the AD12-8) to the AIM-16. If Option P is installed on your AIM-16(s), 5V computer power is used by that option to generate isolated $\pm 15V$ for the analog circuits on AIM-16 (Otherwise, $\pm 12V$ computer power is used.). Since each AIM-16 can draw up to 125mA of current when Option P is installed, it is desirable to keep the total cable length from the A/D to the furthest AIM-16 as short as possible. You can tell if Option P is installed on your AIM-16(s) by looking at the lower-left quadrant of the board. If Option P is not installed, then there will be components absent in that area. If long cable length is required, you can use an external +5VDC power supply and locate it close to the AIM-16 to be powered. This, of course, will necessitate disconnecting the +5VDC computer power.

Also, if Option P is included on your card, it is desirable to have no more than three AIM-16s in any one "chain"; particularly if the REF OUT voltage is to be used as excitation for sensors. For applications where multiple AIM-16s are to be used, CAB37-18Y cables can be used. That cable provides ability to branch to two other AIM-16s. For example, consider the case where five AIM-16s are needed. In this case two CAB37-18Y and one CAB37-18 can be used as shown below.

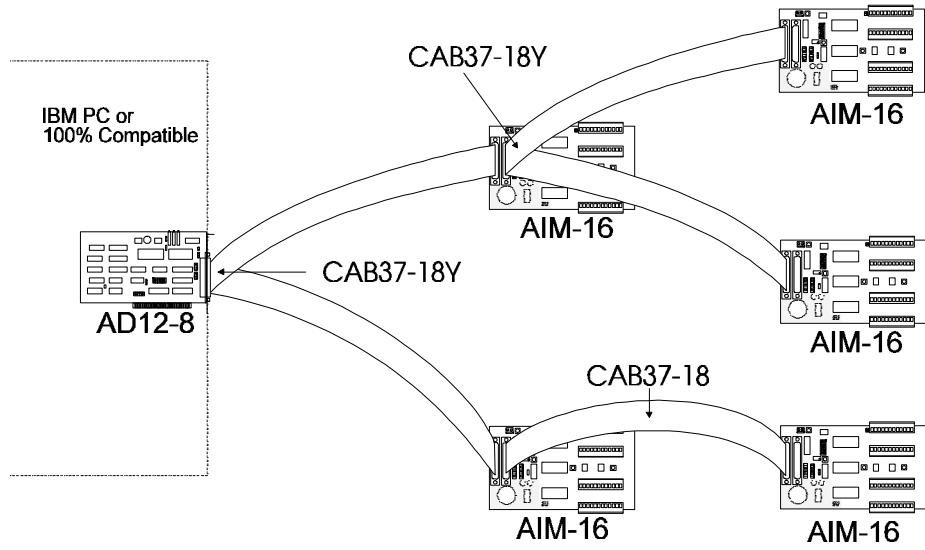

Figure 2-1: Use of CAB-37Y Cables

Option Selection

AIM-16 options are selected either by the DIP switch for High Offset and Gain setup, or by installing plug-in jumpers or solder shunts between labeled points for other options. Refer to Option Selection Map for the location of the jumper, short, and switch selections discussed below. The SETMUX program included with AD12-8 is a special program to assist you in setting up the card. The program uses a menu and illustrations to make it easy to select jumper and switch choices. For further information on this program see Software. If it is necessary to reconfigure a card, it is important to remove any jumper, short, or current resistor not required by the new configuration.

Output Range

A switch labeled G/2 (Switch 1 of DIP switch S1) selects the full scale output of the AIM-16 board and divides the overall gain by two. When G/2 is on, the maximum usable output of AIM-16 is $\pm 5V$.

Gain Selection

The AIM-16 may be operated in the programmable gain mode, the manual gain mode or a combination of the two. The following sections detail the setup for each mode cf. AIM-16 Gain Table lists the switch positions and resulting gains.

Programmable Gain Mode

To select the Programmable Gain Mode of operation, the following switch settings are required:

Switches: GP0, GP1, GP2ON
Switches: GM0, GM1, GM2OFF

In this mode, gains are determined by the state of digital inputs G0, G1, and G2, at I/O connector pins 3, 5, and 6 respectively. By manipulating the digital input bits from software, gains may be programmed on a channel-by-channel basis. See AIM-16 Gain Table for the states of G0, G1 and G2 required for the desired gain.

Manual Gain Mode

To select the Manual Gain Mode of operation, the following switch settings are required:

Switches: GP0, GP1, GP2OFF
Switches: GM0, GM1, GM2Depending on gain

In this mode, gains are determined by the position of switches GM0, GM1, and GM2. See AIM-16 Gain Table for the positions of GM0, GM1 and GM2 required for the desired gain.

Combination of Gain Mode

In instances where less than three digital input control lines are available for setting programmable gains, a combination of manual and programmable gain may be used. One programmable line gives selection of two gains; two lines gives four available gains; and three the entire eight.

The switch locations marked GP0, GP1, and GP2 correspond to digital input bits G0, G1, and G2 respectively. Any of the digital input bits that are not software supported, should have the corresponding GP switch set to OFF. The corresponding GM switch should be set ON or OFF as desired. For example, if only digital inputs G0 and G1 are available, switch GP2 would be set OFF. If GM2 is set to ON, then gain codes 0, 1, 2, 3 would be available as programmable gains, and if GM2 is set to OFF, then gain codes 4, 5, 6, 7 would be available as programmable gains. See AIM-16 Gain Table for other combinations.

AIM-16 Gain Mode						Gain Code	Resulting Gain	
Programmable Gains			Manual Gains				G/2 Switch	
G2	G1	G0	GM2	GM1	GM0		OFF	ON
0	0	0	ON	ON	ON	0	1	½
0	0	1	ON	ON	OFF	1	2	1
0	1	0	ON	OFF	ON	2	10	5
0	1	1	ON	OFF	OFF	3	50	25
1	0	0	OFF	ON	ON	4	100	50
1	0	1	OFF	ON	OFF	5	200	100
1	1	0	OFF	OFF	ON	6	400	200
1	1	1	OFF	OFF	OFF	7	1000	500

Table 2-1: AIM-16 Gain Table

Channel Selection

This option selects which AD12-8 A/D input channel will be used by the AIM-16. Install a jumper in a one of the positions labeled OV0 through OV7. ("OV" stands for output voltage.) This channel must not be used by any other AIM-16, or reference junction in the system. Usually, the first AIM-16 in a system is set to OV0. If a second AIM-16 is to be used, you can set it's jumper to OV1, a third to OV2, etc.

Reference Junction Temperature Input Channel Selection

When making thermocouple temperature measurements, it is normally desired to assign the Reference Junction Temperature to AIM-16 Input Channel IN0. To configure this, install two jumpers in selection points labeled TMP. These points are located near the Input Channel IN0. Do not connect any other input or sensor to channel IN0, and do not install break-detection shorts B0 or RTD Sensor Selection shorts R0. (See Thermocouple Break Detect Selection and RTD Sensor Selection sections.)

If you desire to assign the Reference Junction Temperature directly to an AD12-8 input channel instead of AIM-16 channel IN0, install a jumper in a selection point labelled OT0 through OT7. ("OT" stands for output temperature.) However, remember that if you do this, this AD12-8 input channel used must not be used for any other input by this or any other card in the system.

Thermocouple Break Detect Selection

If you wish to use the break-detect feature for a given input channel it is necessary to install shorts in two selection points both labeled B"n", where "n" is the AIM-16 input channel number. These points are located near the appropriate channel input. Use this selection only for thermocouple inputs. With the shorts installed, an open thermocouple condition will cause a full-scale negative voltage output on that channel.

Current Inputs

If 4-20mA or other current inputs are to be used. Resistors may be added to points labeled IR1-IR16 on the AIM-16 card. Please see Sensor Interface, Considerations for Current Inputs for more information.

RTD Sensor Selection

To configure a channel for RTD operation, install shorts in two selection points both labeled R"n", where "n" is the channel number. These points are all located near the edge of the board furthest from the connectors in the screw-terminal input area.

RTD Output Offset

For a board dedicated to RTD sensors, a negative output offset may be selected by installing a jumper in the OFST position of the programming point labeled "OFST STD". This option is used in cases where you wish to extend the range of an RTD channel.

If this feature is used, then the DIP switch S1 position labeled OSH determines the amount of the offset. With OSH set ON, the offset is -10V and with OSH set OFF, the offset is -5V. See the Considerations for RTD Sensors section in Sensor Interface of this manual for further information on using RTD sensors.

Power Supply Selection

If you have ordered an AIM-16 with the P option (AIM-16P), there are two power supply jumpers. These are labelled -VS and +VS. On the AIM-16P, the jumpers are installed in the +15V and -15V positions. Moving these jumpers to the +12V and the -12V positions disables the on-board power supply and connects the power supplied at the external I/O connector, pin1 for +VS and pin 20 for -VS. The maximum allowable external voltage $\pm 18V$. It is mandatory that only a single +VS and a single -VS jumper be used. When an AIM-16 is purchased without the P option, two shorts are soldered at the -12 and +12 positions.

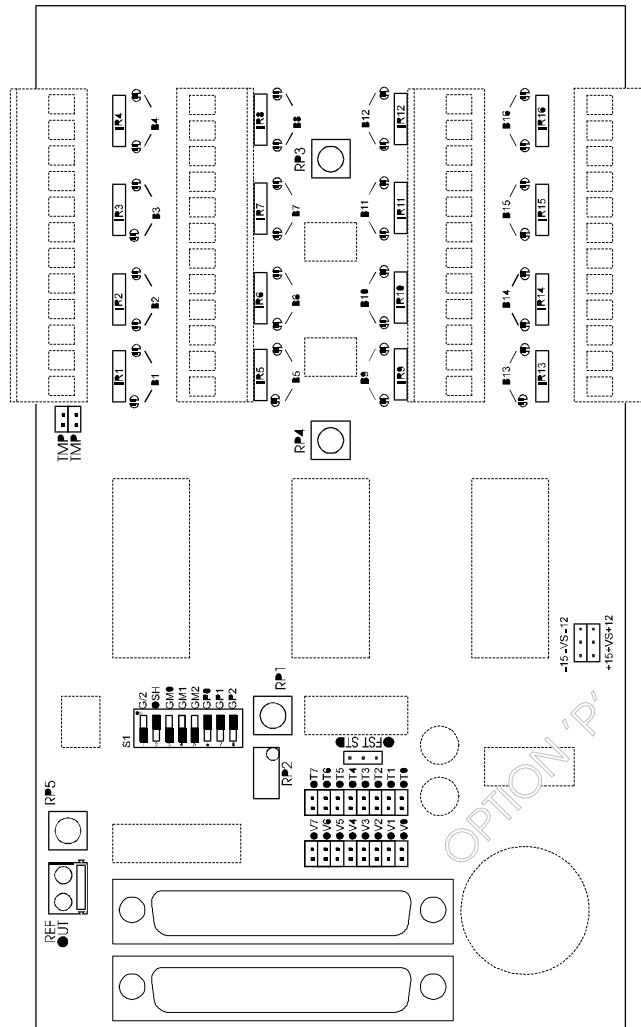

Figure 2-2: AIM-16 Option Selection Map

Calibration and Test

All ACCES cards are calibrated prior to shipment. However, periodic calibration of AIM-16 is recommended to retain full accuracy. The calibration interval depends to a large extent on the type of service that the card is subjected to. For environments where there are frequent large changes of temperature and/or vibration, a three-month interval is suggested. For laboratory or office conditions, six months to a year is acceptable.

A 4-1/2 digit digital multimeter is required as a minimum to perform satisfactory calibration. Also, a voltage calibrator or a stable, noise-free, DC voltage source that can be used in conjunction with the digital multimeter is required.

Calibration is performed using the SETMUX program supplied with the AD12-8. This program will lead you through the set up and calibration procedure with prompts and graphic displays that show the settings and adjustment trim pots. This calibration program also serves as a useful test of the AIM-16 functions and can aid in troubleshooting if problems arise.

Calibration Procedure

The AIM-16 card has five potentiometers RP1 through RP5, which are used for calibration. These potentiometers have the following functions:

- d. RP1 sets an output offset of the programmable gain amplifier (U13) to zero.
- e. RP2 sets an input offset of the programmable gain amplifier (U13) to zero.
- f. RP3 sets the level of the +10V regulated supply.
- g. RP4 sets the output of the local reference junction temperature sensor.
- h. RP5 is a fine gain adjust and provides precise gain setting capability.

The following procedure is brief and is intended for use in conjunction with the calibration part of the SETMUX program.

1. Start the calibration program by typing SETMUX and press the ENTER key at the DOS prompt.
2. Use the relevant menu selection to assign your AIM-16 to a channel of the AD12-8.
3. Use the arrow key to select option 6) Calibrate MUX, then press the ENTER key.
4. Now select which AIM-16 to calibrate and press ENTER.
5. You will be presented with an initial setup for the AIM-16, ensure that your card is set this way then press ENTER.
6. Use the arrow key to select option 1. Adjust RP3, from the menu at the top left hand corner of the screen.
7. Following the instructions on the screen, perform the RP3 adjustment
8. Repeat steps 6) and 7) for RP4, RP1, RP2, and RP5.
9. This completes the calibration procedure.

Chapter 3: Software

The AIM-16 does not have software included with it, as software for a system is largely dependent upon the A/D card used. The AD12-8 A/D card has a full range of software included with it that includes support for the AIM-16 as follows. See "Directories Created on the Hard Disk" in the Installation section for a complete software description.

Drivers

Hardware drivers included with the AD12-8 are designed to use the advanced features of the AIM-16 such as programmable gains and on-board reference-junction compensation. The drivers support "C", Pascal, QuickBASIC and interpreted BASIC. In addition, a driver is provided in DLL form for Windows applications

The driver also supports a point list, which allows assignment of point addresses with gain, in any order desired. This allows A/D points in the system to be scanned in any order.

Sample Programs

Two sample programs directly use the AIM-16. SAMPLE2 performs timer-driven interrupts using all channels of a single AIM-16. This program can be easily modified to support the maximum number of eight AIM-16s.

SAMPLE3 performs similar functions to SAMPLE2 but uses the SETUP.CFG configuration file to setup the driver. If you compare the two samples, you will see the substantial decrease in program code required when using this auto configuration.

SETMUX

The SETMUX setup utility program provides a graphical reference to assist you in configuring your AIM-16 for the various features provided by this card. The setup program allows you to assign AIM-16s or reference junctions to any of the eight A/D channels.

After you assign your AIM-16s to their respective A/D channels, you may make individual channel assignments for the various types of inputs supported, such as thermocouples or voltage inputs using any of the programmable gains supported.

Upon exiting the SETMUX program, the setup and configuration information is stored in a file called SETUP.CFG. The drivers or your own application program can then use this file to determine the configuration of your system.

SETMUX also provides for calibration of your AIM-16. See the Calibration and Test section of Installation for instructions on using this feature.

Chapter 4: Sensor Interface

Before attempting to program or set up the AIM-16, the overall system of which the AIM-16 is a part should be defined. The AIM-16 provides the system's interface to the various sensors which supply data. We suggest that you make a list of sensors by type and location. Where practical, sensors of one type should be grouped on the AIM-16 card to simplify programming.

Considerations for Thermocouples

It is important that the junction temperature from each card be used in computing the temperature measured by each thermocouple serviced by that card. In order to minimize errors, the junction temperature sensor is physically located at a place central to all thermocouple connections. The junction temperature sensor input is normally jumpered to input channel IN0 of each card. A selection of Gain=1 is suggested for that channel, as it will produce nominal 24.4 mV/°C. If the AIM-16 is not enclosed (e.g., in ACCES' T-Box), then care should be taken that there is not air blowing across the AIM-16. Moving air can cause a small temperature differential, which results in a "reference junction error".

A total of eight AIM-16 cards per system may be used with an AD12-8. Thus, up to 120 thermocouple inputs can be accommodated (Eight analog input channels used for reference junction overhead).

An open thermocouple or "break-detect" signal is available and may be activated by installing two shorts at each channel where break detect is desired. Break-detect short locations are labelled B1 through B16. For example, install two shorts at the two locations labelled B2 in order to enable the break-detect feature for channel 2. Now, when an open or missing thermocouple is detected, a full-scale negative output will be provided on channel 2.

A jumper should be installed in the STD position of the programming point labeled "OFST STD". The OFFSET feature is used for RTDs, for 4-20mA current measurement, and other current measurements. This feature will be discussed under appropriate paragraphs on the following pages.

Considerations for RTD Sensors

Three-wire connection may be applied to an RTD sensor by adding two shorts per channel for each sensor served. The locations for these shorts are labelled R0 through R15. For example, install two shorts in the two locations labeled R2 if an RTD sensor is used at channel 2.

For extended range and resolution of measurements, it is common practice in RTD processing to offset the sensor output in a negative direction. The AIM-16 allows a negative 10V offset, so that a zero input to a channel provides a -10V output. In order to enable this feature install a jumper in the OFST position of the programming point labeled OFST STD and place the DIP switch labeled OSH in the ON position.

If the host A to D card is rated at $\pm 5V$ full scale, install the OFST STD jumper as above but place the OSH switch in the OFF position. This will reduce the offset to -5V.

While this offset increases the range and resolution of RTD operation, remember that it is a selection that affects all channels on a given card.

Connections to an RTD sensor are as follows: the V+, I+ lead to the "+" input; the V- lead to the "-" input; and the I- to the "GND" input.

If all of your sensors are RTDs, model AIM-16R is designed specifically for RTDs.

Considerations for Strain Gage Sensors

A ratiometric reading of a strain gage sensor requires input to two channels of an AIM-16 card. One channel measures the sensor excitation while the other channel reads the sensor output. The host computer computes the output as a ratio of the sensor output to sensor excitation. This requires different gains for each signal, nominally a gain of 1 for the excitation and 200 for the signal. Thus, strain gage measurement requires the use of programmable gain on an AIM-16 board.

Excitation for the strain gage(s) is available at a screw terminal block on the AIM-16. That excitation is derived from the AD12-8's precision 10V reference voltage and can supply over 200mA current.

A jumper should be installed in the STD position of the programming point labeled "OFST STD". When the STD position is selected, no offset is produced.

Considerations for Current Inputs

The AIM-16 card has provisions for reading input current. Reserved space and board connections are available for 16 precision resistors. To utilize this provision, it is only necessary to install a resistor of the proper value and set the gain appropriately for each channel to be used for current input.

When all inputs are designated for sensing 4-20mA current, it is beneficial to increase resolution by providing offset. To accomplish this, install a jumper in the OFST position of the programming point labelled "OFST STD". Alternatively, if the A/D card operates on $\pm 10V$ range, set DIP switch #2 "on" ; i.e. OSH (offset-high) position.

If the AIM-16 that you have is model AIM-16I, then it already has the current-sensing resistors installed. Further, it has also been modified so that maximum resolution is provided at the A/D converter. The modifications that are made include introduction of an offset and addition of a gain adjustment pot.

To better understand the modifications, consider the following. If the A/D converter input range is $\pm 5V$, the AIM-16 amplifier gain is 1, and a 250-ohm resistor is used, then a 4-20mA current input would yield voltages of +1V to +5V at the AIM-16 output. Only 40% of the A/D converter range would be used! To accomplish better resolution, it is necessary to introduce an offset and amplifier gain. For example, if a -5V offset is introduced and the amplifier gain is increased to 2, then the output would be -3V to +5V. But that is still only 80% of the A/D converter's range

So, to cover the full range (and thus realize maximum resolution), an additional offset is required to accommodate the 4mA "live zero". On the AIM-16I, standard 200-ohm (0.1%) resistors are used in place of 250-ohm resistors. This would yield +2.496V to +12.48V after amplification. An offset is applied and the net output is -5.004V to +4.980V. The amplifier gain is adjusted slightly with gain adjust pot RP5 to compensate for the fact that 200 ohms is slightly low.

Considerations for Other Voltage Inputs

The input voltage to AIM-16 should be within a range of $\pm 10V$. Any gain selected should allow the output to stay within the full-scale range of the host analog-to-digital converter. If you know that the input voltage falls within those limits but don't know exactly what it is, software controlled auto-ranging capability is available via the gain/curve setup routine provided with the AD12-8 setup software.

Appendix A: Cabling and Connector Information

Input Connector Pin Assignments

Connections are made to the AIM-16 card via a 37-pin D type connector. The female mating connector can be a Cannon #DC-37S for soldered connections. Alternatively, insulation-displacement flat cable types such as AMP #745242-1 may be used.

Pin	Name	Function
1	+VS	+12VDC Power from the Computer Bus
2	unused	
3	G0	LSB of programmable gain control
4	unused	
5	G1	Bit 1 of programmable gain control
6	G2	MSB of programmable gain control
7	A0	LSB sub-multiplexer channel select
8	A1	Bit 1 sub-multiplexer channel select
9	A2	Bit 2 sub-multiplexer channel select
10	A3	MSB sub-multiplexer channel select
11	PWR GND	Power (Digital) ground
12	unused	
13	unused	
14	unused	
15	unused	
16	unused	
17	unused	
18	L.L. GND	Low Level (Analog) Ground
19	VREF	+10.0VDC A/D reference from A/D card
20	-VS	-12VDC Power from the Computer Bus
21	unused	
22	unused	
23	unused	
24	unused	
25	unused	
26	unused	
27	unused	
28	REF GND	A/D Reference Return
29	+5VDC	+5VDC Power from the Computer Bus
30	CH7 IN	Chl 7 Analog Output
31	CH6 IN	Chl 6 Analog Output
32	CH5 IN	Chl 5 Analog Output
33	CH4 IN	Chl 4 Analog Output

34	CH3 IN	Chl 3 Analog Output
35	CH2 IN	Chl 2 Analog Output
36	CH1 IN	Chl 1 Analog Output
37	CH0 IN	Chl 0 Analog Output

Table A-1: Connector Pin Assignments

Customer Comments

If you experience any problems with this manual or just want to give us some feedback, please email us at: manuals@accessioproducts.com.. Please detail any errors you find and include your mailing address so that we can send you any manual updates.



10623 Roselle Street, San Diego CA 92121
Tel. (619)550-9559 FAX (619)550-7322
www.accessioproducts.com

Free Manuals Download Website

<http://myh66.com>

<http://usermanuals.us>

<http://www.somanuals.com>

<http://www.4manuals.cc>

<http://www.manual-lib.com>

<http://www.404manual.com>

<http://www.luxmanual.com>

<http://aubethermostatmanual.com>

Golf course search by state

<http://golfingnear.com>

Email search by domain

<http://emailbydomain.com>

Auto manuals search

<http://auto.somanuals.com>

TV manuals search

<http://tv.somanuals.com>