

Studio MMP3400 Service Guide

Service guide files and updates are available on the ACER/CSD web; for more information, please refer to <http://csd.acer.com.tw>



PRINTED IN TAIWAN

Revision History

Please refer to the table below for the updates made on Studio MMP3400 service guide.

Date	Chapter	Updates

Copyright

Copyright © 2009 by Acer Incorporated. All rights reserved. No part of this publication may be reproduced, transmitted, transcribed, stored in a retrieval system, or translated into any language or computer language, in any form or by any means, electronic, mechanical, magnetic, optical, chemical, manual or otherwise, without the prior written permission of Acer Incorporated.

Disclaimer

The information in this guide is subject to change without notice.

Acer Incorporated makes no representations or warranties, either expressed or implied, with respect to the contents hereof and specifically disclaims any warranties of merchantability or fitness for any particular purpose. Any Acer Incorporated software described in this manual is sold or licensed "as is". Should the programs prove defective following their purchase, the buyer (and not Acer Incorporated, its distributor, or its dealer) assumes the entire cost of all necessary servicing, repair, and any incidental or consequential damages resulting from any defect in the software.

Acer is a registered trademark of Acer Corporation.

Intel is a registered trademark of Intel Corporation.

Other brand and product names are trademarks and/or registered trademarks of their respective holders.

Conventions

The following conventions are used in this manual:

SCREEN MESSAGES	Denotes actual messages that appear on screen.
NOTE	Gives bits and pieces of additional information related to the current topic.
WARNING	Alerts you to any damage that might result from doing or not doing specific actions.
CAUTION	Gives precautionary measures to avoid possible hardware or software problems.
IMPORTANT	Reminds you to do specific actions relevant to the accomplishment of procedures.

Preface

Before using this information and the product it supports, please read the following general information.

1. This Service Guide provides you with all technical information relating to the BASIC CONFIGURATION decided for Acer's "global" product offering. To better fit local market requirements and enhance product competitiveness, your regional office MAY have decided to extend the functionality of a machine (e.g. add-on card, modem, or extra memory capability). These LOCALIZED FEATURES will NOT be covered in this generic service guide. In such cases, please contact your regional offices or the responsible personnel/channel to provide you with further technical details.
2. Please note WHEN ORDERING FRU PARTS, that you should check the most up-to-date information available on your regional web or channel. If, for whatever reason, a part number change is made, it will not be noted in the printed Service Guide. For ACER-AUTHORIZED SERVICE PROVIDERS, your Acer office may have a DIFFERENT part number code to those given in the FRU list of this printed Service Guide. You MUST use the list provided by your regional Acer office to order FRU parts for repair and service of customer machines.

Table of Contents

Chapter 1	System Specifications	1
	Features	1
	I/O interface:	1
	Studio MMP3400 System Block Diagram	3
	Your Studio MMP3400 tour	4
	Disassembly/Reassembly Requirements	7
	Pre-disassembly Instructions	7
Chapter 2	Machine Disassembly and Replacement	7
	Disassembly Process	8
	Removing the Outer Casing	8
	Removing the Base	9
	Removing the Hard Drive	10
	Removing the Fan Module	11
	Removing the IR Board	13
	Removing the Main Board	14
	Reassembly Process	16
	Main Board Reassembly	16
	IR Board Reassembly	17
	Fan Module Reassembly	18
	Hard Drive Reassembly	20
	Base Reassembly	21
	Outer Casing Reassembly	22
Chapter 3	Troubleshooting	25
	No display on TV	25
	No sound or poor sound quality	25
	No picture or poor picture quality	25
	Not recognised by computer	25
	The remote control does not work well	25
	Subtitles are not displayed when watching a DivX movie	25
	No SPDIF audio out	25
	How to upgrade firmware	26
	Main Board Layout	29
Chapter 4	Connector Locations and Board Layout	29
	Rear I/O Connectors	30
	IR Board Placement	30
Chapter 5	FRU (Field Replaceable Unit) List	31
Index		35

System Specifications

Features

Below is a brief summary of the Studio MMP3400's feature:

- Main Chip : ESS ES6461
- Main Memory : 16MB SDRAM, 8Mx16 x1pcs.
- Serial Flash : 2MB SPI Flash.
- Stereo Audio DAC: ES64641 build in
- Build in 3.5" SATA HDD
- USB Bridge: Genesys GL830
- HDMI TX:ESS ES7109
- Dimension (L x H x W): 218 mm x 151 mm x 55 mm
- Weight: ± 1388g (2 TB HDD), ± 1058g (500 GB HDD), Accessories: 400g

NOTE: Weight may vary depending on the HDD installed.

I/O interface:

Rear Side

- USB 2.0 Host Port x 1. (A Type)
- Phone Jack For Component Y/PB/PR x 1.
- Phone Jack For Composite CVBS/Audio-R/Audio-L x 1.
- HDMI Port x 1.
- S/PDIF Digital Audio Out x1
- DC Power Input Jack x 1.
- Mini USB Device Port x 1.

Front Side

- 38KHz IR receiver x 1.
- Power on status/ HDD access LED x 1

Other

- PSU: AC Wall Wart, DC 12V@2A
- Main board PCB Size: 115mm x 90mm,4L.
- Front board PCB Size:30mm x 5mm,2L.
- MPEG-1,MPEG-2, XViD, AVI decoding
- Video Decoding resolution is up to 480p
- video output 480p and scaling up to 1080P
- The product provides the following distinctive operation modes
 - Music playback
 - Photo rendering and slide show with effects and with music in the background
 - Video viewing

-
- System setup
 - USB 2.0 HOST port x 1 and Mini USB Device port x1 in Rear I/O.
 - Video output support
 - Component video up to 1080i
 - CVBS –PAL system
 - HDMI—480p up scaling to 1080P
 - Audio output support
 - Stereo audio out
 - SPDIF audio out
 - Dolby certification

Studio MMP3400 System Block Diagram

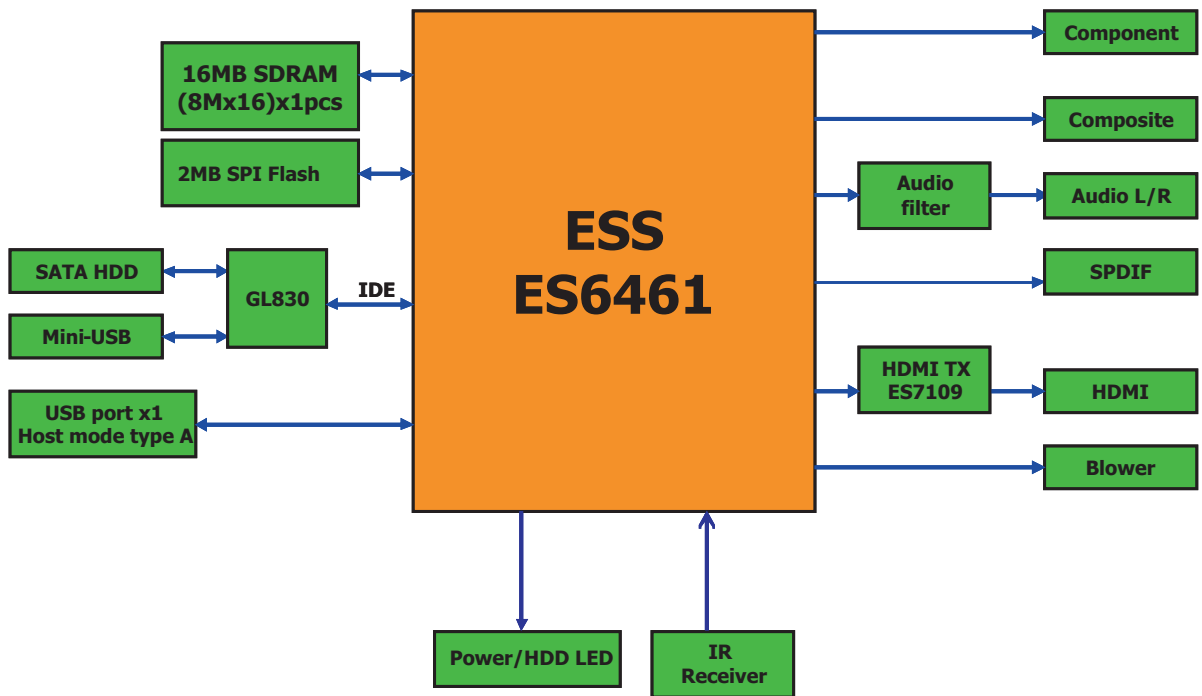

Your Studio MMP3400 tour

Appearance

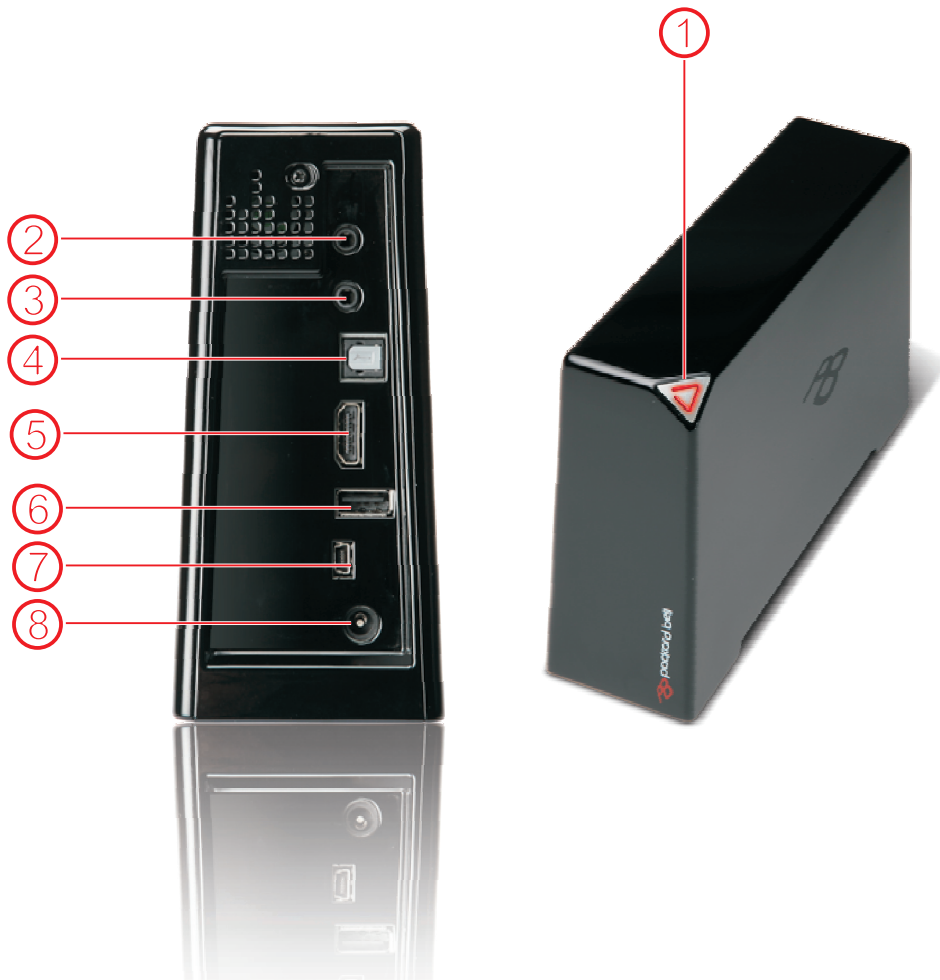

#	Item	Description
1	Connection Light	<ul style="list-style-type: none"> • Red - On • Flashing - Hard drive activity • Off - Standby
2	High Definition Video Out	This connector provides a high definition video signal. The YPbPr cable must be connected to this port.
3	A/V Out	This connector provides video and analogue audio signals. The provided cable includes S-Video, Composite video and stereo audio outputs.
4	SPDIF	This interface is used to transfer compressed digital audio and carry the signal between the output in your system to a home theater system designed for Dolby Digital, DTS surround sound or used to inter-connect commercial audio equipment.
5	HDMI	This connector provides a high definition audio and video signal. The HDMI cable must be connected to this port and outputs to a monitor or HDTV with HDMI input port.
6	USB host	To connect a USB key.
7	USB port	When the Studio is connected to a computer, this port is used to transfer files via a USB cable.
8	Power connector	The AC adapter must be connected to this port.

Removet Control

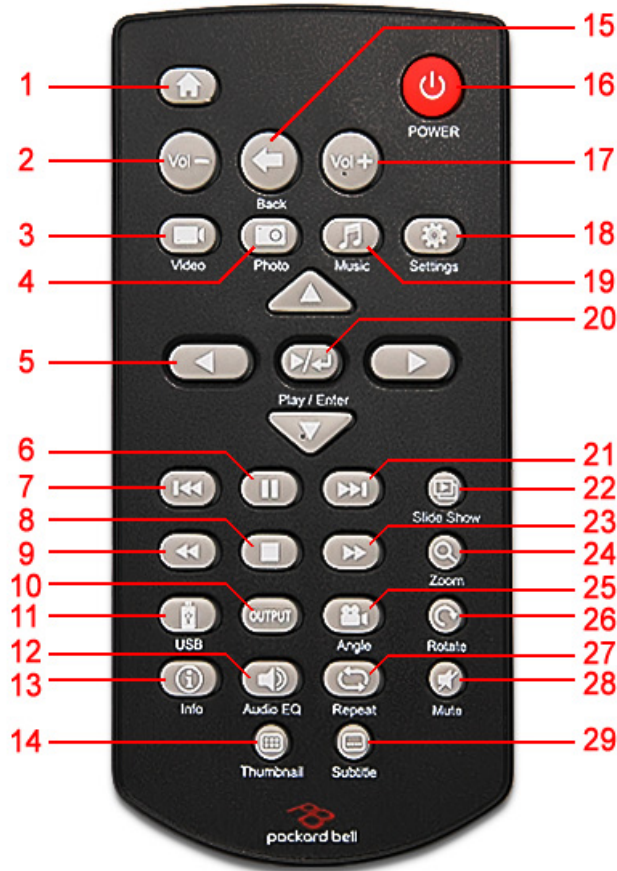

#	Button	Function depends on active selection:			
		Movie	Music	Picture	Settings
1	HOME	Display the main menu			
2	VOL -	Decrease volume		-	
3	VIDEO	Go to the Video screen			
4	PHOTO	Go to the Photo screen			
5	DIRECTION KEYS	Go up, down, left, right. Left arrow: go up one directory.			
		Go back/forward 12 seconds during playback		Go to previous/next image. Move up/down/left/right in zoom mode.	-
6	PAUSE	Pause during playback		Pause slideshow	-
7	SKIP-	Go to previous movie	Go to previous song	Go to previous image	-
8	STOP	Stop playback		Stop slideshow	-
9	FAST REWIND	Reverse play		-	
10	OUTPUT	Toggle video out format. You can switch between the individual video outputs pressing this button. The video output selected at any time will be shown on the screen. If you cannot see the correct image on a TV or VGA screen, press this button until the image appears.			
11	USB	Go to the USB device that is connected to the USB port on your Studio.			

#	Button	Function depends on active selection:			
		Movie	Music	Picture	Settings
12	AUDIO/EQ	Switch audio track during playback	Adjust the music playback effect	Adjust the music playback effect during music slideshow	-
13	INFO	Displays file information (e.g. size, format, etc.) during playback			-
14	THUMBNAILS	Displays image preview			-
15	BACK	Return to playlist during playback	-	Return to playlist during playback	Return to the main menu
		Return to the previous menu			
16	POWER	Power On/Off			
17	VOL +	Increase volume			
18	SETTINGS	Go to the Settings screen			
19	MUSIC	Go to the Music screen			
20	PLAY/ENTER	Play a movie	Play a song	Display an image	Select
21	SKIP +	Go to next movie	Go to next song	Go to next image	-
22	SLIDESHOW	-	Play all files as a slideshow		-
23	FAST FORWARD	Fast forward		-	
24	ZOOM	-		Zoom in/out (2x, 4x, 8x)	-
25	ANGLE	Not used			
26	ROTATE	-		Rotate image (90° clockwise)	-
27	REPEAT	Repeat playback (Repeat One, Repeat All, Shuffle, None)		Repeat slideshow	-
28	MUTE	Mute the sound		Mute sound during slideshow	-
29	SUBTITLE	Toggle language subtitles	-		

Machine Disassembly and Replacement

This chapter contains step-by-step procedures on how to disassemble and reassemble the Studio MMP3400 for maintenance and troubleshooting.

Disassembly/Reassembly Requirements

To disassemble or reassemble the computer, you need the following tools:

- Wrist grounding strap and conductive mat for preventing electrostatic discharge



- Philips screwdriver (may require different size)



- Tweezers



NOTE: The screws for the different components vary in size. During the disassembly process, group the screws with the corresponding components to avoid mismatch when putting back the components.

Pre-disassembly Instructions

Before proceeding with the disassembly procedure, make sure that you do the following:

1. Turn off the power to the system and all peripherals.
2. Unplug the AC adapter and all power and signal cables from the system.
3. Place the system on a flat, stable surface.

Disassembly Process

This section guide you on how to disassemble the Studio MMP3400 when you need to perform system service of to replace a replaceable parts.

The list below are the list of screws used in the Studio MMP3400.

Main Screw List

Item	Color	Torque	Part No.
A	Black	4.5kgf-cm	86.SA33Q.8R0
B	Silver	6.0kgf-cm	86.9A532.6R0
C	Silver	1.5kgf-cm	86.9A552.5R0
D	Silver	6.0kgf-cm	86.5A534.4R0

Removing the Outer Casing

1. Remove the rubber foot near the front of the system.



2. Remove the screws (A) from where the rubber foot was and at the back of the system.



Step	(Quantity)	Color	Torque
1~2	2	Black	4.5 kgf-cm

- Carefully release the latches and carefully lift up the outer casing.



Removing the Base

- See "Removing the Outer Casing" on page 8.
- Remove the one screw (B) securing the base to the housing.



Step	(Quantity)	Color	Torque
1	1	Silver	6.0 kgf-cm

3. Release the latches and carefully lift up the housing.

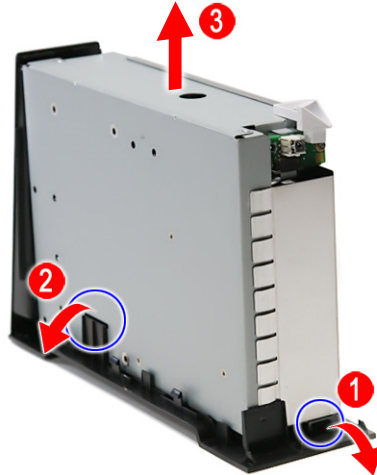

Removing the Hard Drive

1. See "Removing the Outer Casing" on page 8.
2. See "Removing the Base" on page 9.
3. Carefully slide out the metal shielding.



4. Remove the three screws (B) securing the hard drive to the housing.

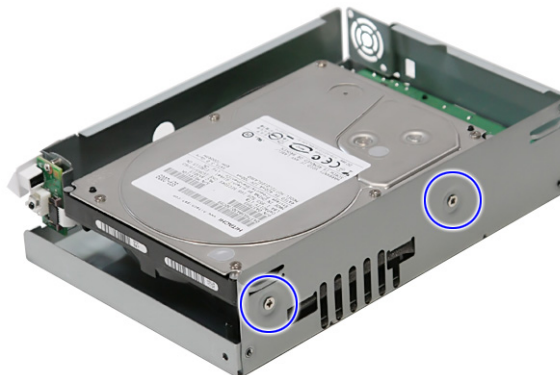



Step	(Quantity)	Color	Torque
1~3	3	Silver	6.0 kgf-cm

5. Slide out the hard drive and remove it from the housing.



NOTE: To prevent damage to device, avoid pressing down on it or placing heavy objects on top of it.

Removing the Fan Module

1. See “Removing the Outer Casing” on page 8.
2. See “Removing the Base” on page 9.
3. See “Removing the Hard Drive” on page 10.
4. Disconnect the fan cable from CN4 on the main board.



5. Remove the three screws (C) securing the fan module to the housing.



Step	(Quantity)	Color	Torque
1~3	3	Silver	1.5 kgf-cm

6. Remove the fan module from the housing.



Removing the IR Board

1. See “Removing the Outer Casing” on page 8.
2. See “Removing the Base” on page 9.
3. See “Removing the Hard Drive” on page 10.
4. See “Removing the Fan Module” on page 11.
5. Disconnect the IR cable from the IR board connector.

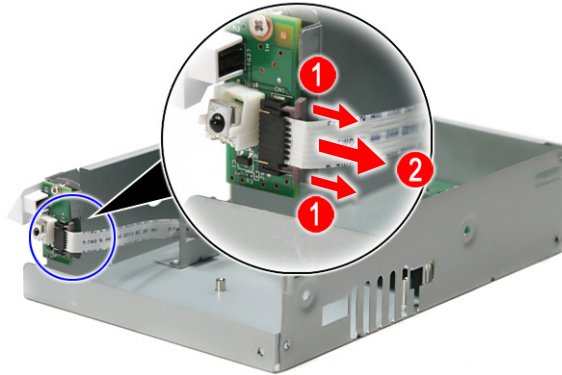

6. Remove the one screw (C) securing the LED bracket.



Step	(Quantity)	Color	Torque
1	1	Silver	1.5 kgf-cm

7. Remove the LED bracket.

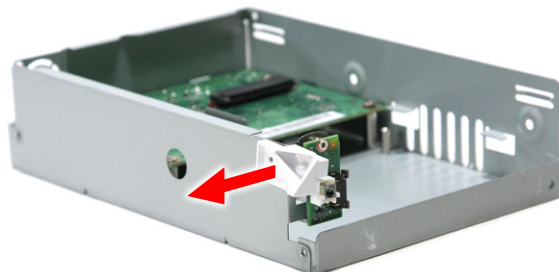

- Remove the one screw (C) securing the IR board to the housing.



Step	(Quantity)	Color	Torque
1	1	Silver	1.5 kgf-cm

- Remove the IR board from the housing.

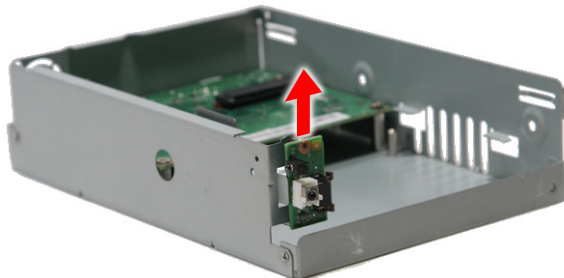

Removing the Main Board

- See "Removing the Outer Casing" on page 8.
- See "Removing the Base" on page 9.
- See "Removing the Hard Drive" on page 10.
- See "Removing the Fan Module" on page 11.
- See "Removing the IR Board" on page 13.
- Remove the four screws (B) securing the main board to the housing.



Step	(Quantity)	Color	Torque
1~4	4	Silver	6.0 kgf-cm

7. Remove the one screw (D) near the HDMI connector.

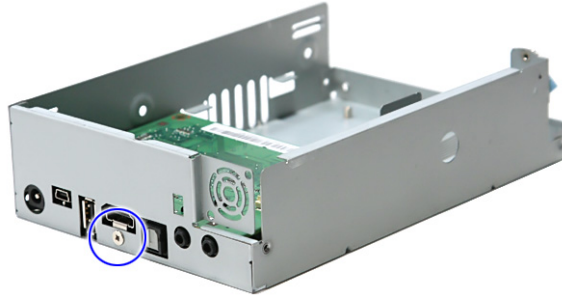

Step	(Quantity)	Color	Torque
1	1	Silver	6.0 kgf-cm

8. Carefully lift up and remove the main board from the housing.

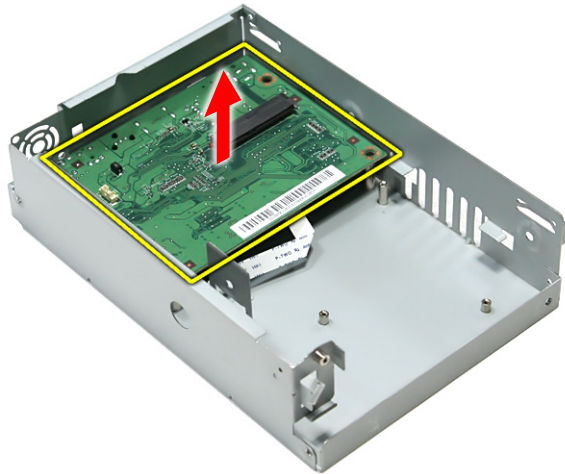

Note: Circuit board >10 cm² has been highlighted with the yellow rectangle as above image shows. Please detach the Circuit boards and follow local regulations for disposal.

9. Disconnect the IR cable from the main board.

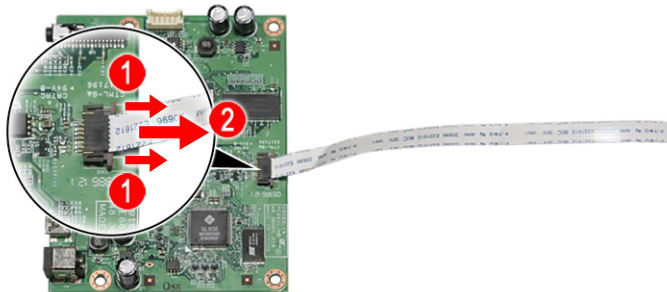

Reassembly Process

This section guide you on how to reassemble the Studio MMP3400 after maintenance and troubleshooting.

Main Board Reassembly

1. Reconnect the IR cable into the main board.

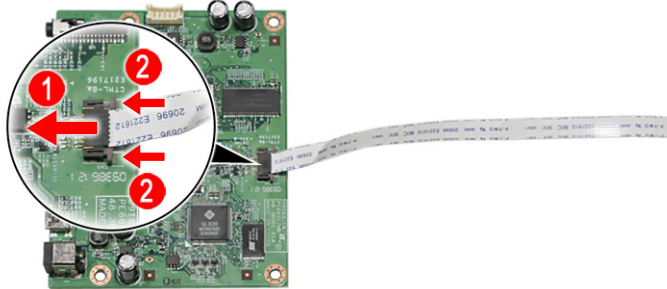

2. Replace the main board into the housing.



3. Replace the one screw (D) near the HDMI connector.



Step	(Quantity)	Color	Torque
1	1	Silver	6.0 kgf-cm

- Replace main board and secure it to the housing with the four screws (B).



Step	(Quantity)	Color	Torque
1~4	4	Silver	6.0 kgf-cm

IR Board Reassembly

- See “Main Board Reassembly” on page 16.
- Replace the IR board and secure it to the housing with the one screw (C).



Step	(Quantity)	Color	Torque
1	1	Silver	1.5 kgf-cm

3. Replace the LED bracket and secure it to the housing with the one screw (C).

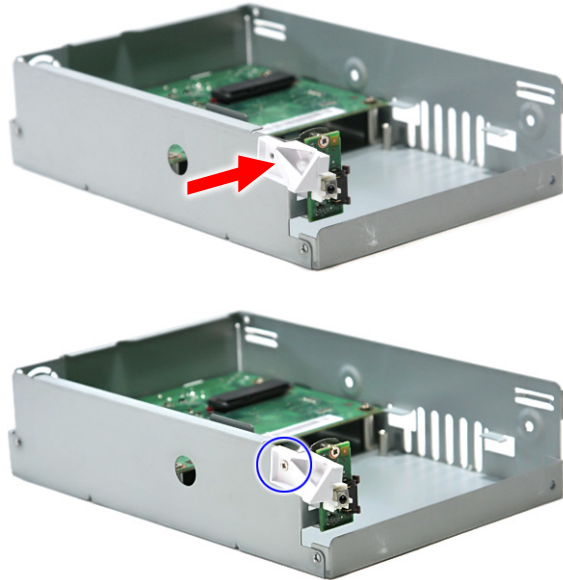

Step	(Quantity)	Color	Torque
1	1	Silver	1.5 kgf-cm

4. Reconnect the IR cable into the IR board connector CN1.

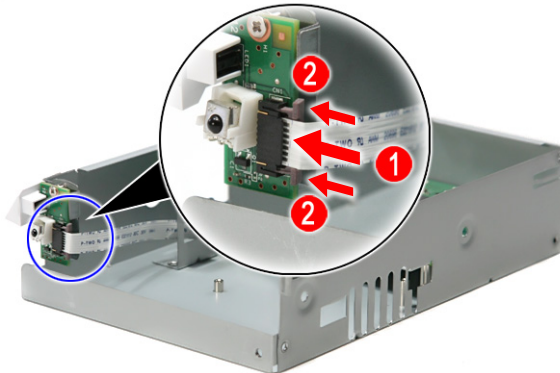

Fan Module Reassembly

1. See “Main Board Reassembly” on page 16.
2. See “IR Board Reassembly” on page 17.

3. Replace the fan module and secure it to the housing with the three screws (C).



Step	(Quantity)	Color	Torque
1~3	3	Silver	1.5 kgf-cm

4. Reconnect the fan module cable to the connector CN4 on the main board.



Hard Drive Reassembly

1. See “Main Board Reassembly” on page 16.
2. See “IR Board Reassembly” on page 17.
3. See “Fan Module Reassembly” on page 18.
4. Slide the hard drive until the connector on the hard drive is securely connected to the SATA connector on the main board.

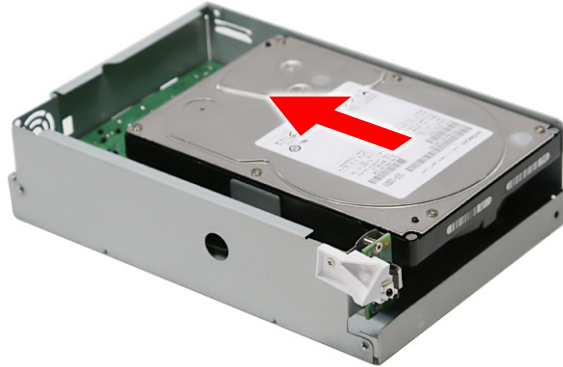

5. Secure the hard drive to the housing with the three screws (B).



Step	(Quantity)	Color	Torque
1~3	3	Silver	6.0 kgf-cm

-
6. Replace the metal shielding to the hard drive.



Base Reassembly

1. See “Main Board Reassembly” on page 16.
2. See “IR Board Reassembly” on page 17.
3. See “Fan Module Reassembly” on page 18.
4. See “Hard Drive Reassembly” on page 20.
5. Replace the housing into the base until the latches clicks into place.

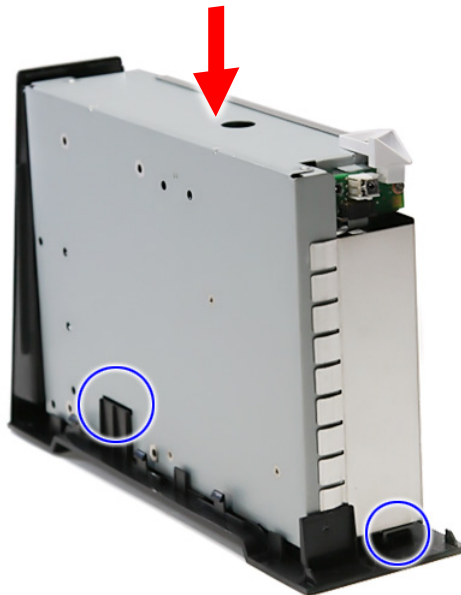

- Secure the housing with the one screw (B).



Step	(Quantity)	Color	Torque
1	1	Silver	6.0 kgf-cm

Outer Casing Reassembly

- See “Main Board Reassembly” on page 16.
- See “IR Board Reassembly” on page 17.
- See “Fan Module Reassembly” on page 18.
- See “Hard Drive Reassembly” on page 20.
- See “Base Reassembly” on page 21.
- Carefully slide down the outer casing into the housing until the latches clicks into place.



-
7. Secure the outer casing to the housing with the two screws (A).



Step	(Quantity)	Color	Torque
1~2	2	Black	4.5 kgf-cm

8. Replace the rubber foot to cover one of the screw.



Troubleshooting

This is a list of possible situations that may arise during the use of your Studio MMP3400, and it gives easy answers and solutions to these questions.

No display on TV

- Make sure the Studio is plugged in and turned on.
- Check whether the TV is powered on and the TV video is in AV mode.
- Make sure that the AV cable is correctly connected to the Studio.
- Please press the OUTPUT button to switch the Studio display mode.
- Make sure the user's TV/Monitor supports PAL/50MHz.

No sound or poor sound quality

- Make sure that the audio cable is correctly connected to the Studio.
- Check whether the Studio is in mute mode and/or volume decreased to minimum.

No picture or poor picture quality

- Make sure that the video cable is correctly connected to the Studio.
- Make sure that the video mode is set correctly.

Not recognised by computer

- Check whether the USB cable is correctly connected to the machine; make sure that the Studio is attached correctly.
- Check that the AC adapter is plugged in and connected correctly.
- Check whether the Studio is on.

The remote control does not work well

- Check whether the battery is inserted correctly and whether or not the battery is out of power.
- The distance between the Studio and control should not be too far.

Subtitles are not displayed when watching a DivX movie

- The Studio can read .srt, .sub and .smi subtitle files. Other subtitle files will not be displayed.
- The subtitle file must have the same name and be in the same directory as the movie file. I.e "movie.avi" and "movie.srt".
- The subtitle file must be in Unicode format. To check this, open the .sub or .srt file with notepad, select "Save As" and choose the Unicode option from the encoding combo box.

No SPDIF audio out

- Check the "SETTINGS" -> "AUDIO OUTPUT" is set "SPDIF/SAW" or "SPDIF/PCM"

How to upgrade firmware

1. Put the firmware into the USB flash drive and plug this USB flash drive into MMP3400.



2. Power on MMP3400 and go to **SETTINGS** menu.

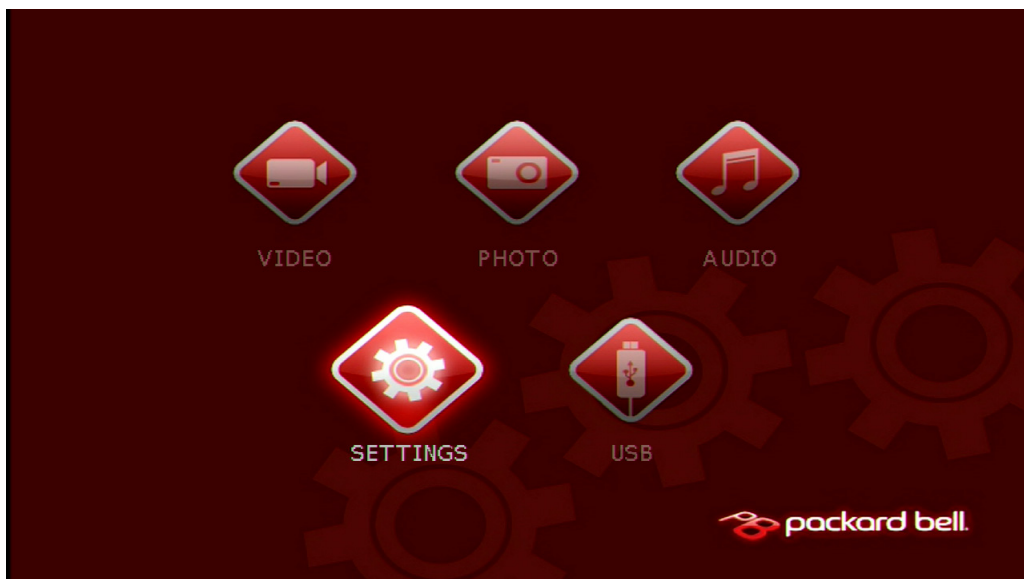

3. In the **SETTINGS** menu, select **PREFERENCES** and use navigation key to highlight **Firmware Upgrade**. Then press **RIGHT** key to highlight **UPGRADE** and press **ENTER**.

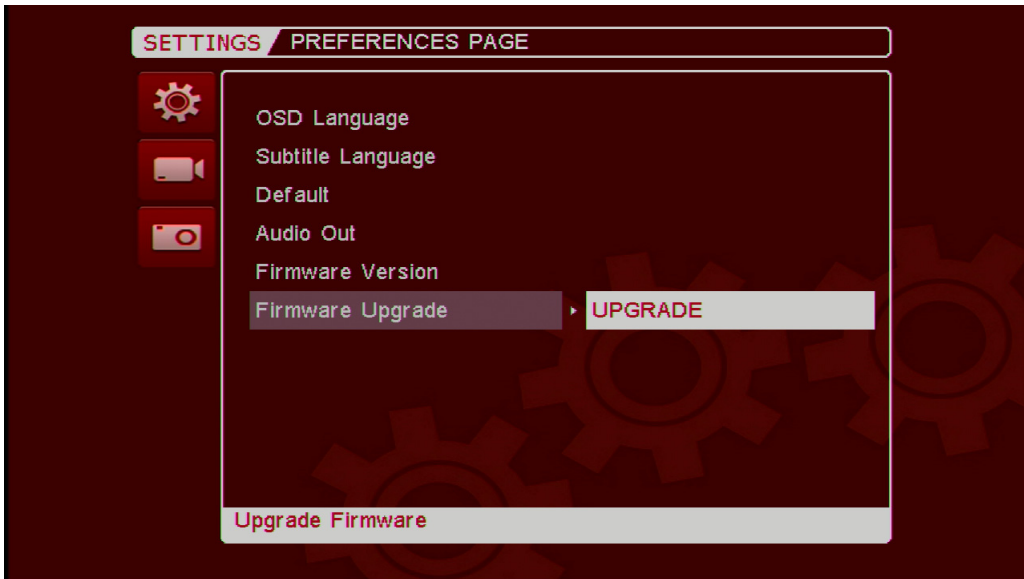

4. System will pop out a confirmation message. Press **LEFT** key to highlight **YES** in red and then press **ENTER**.

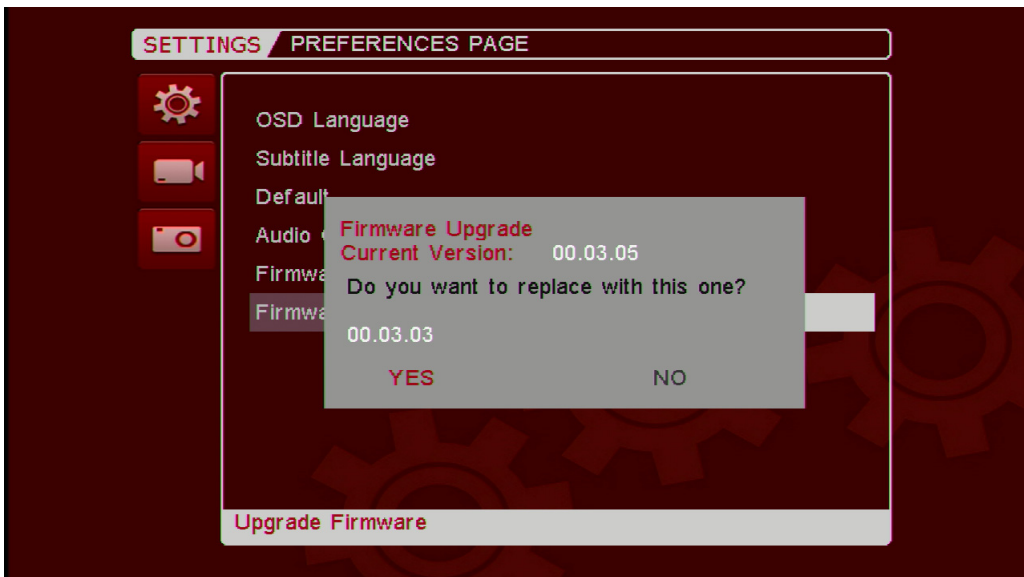

5. System will start to update the firmware. After the system completes the upgrade, it will power on automatically.

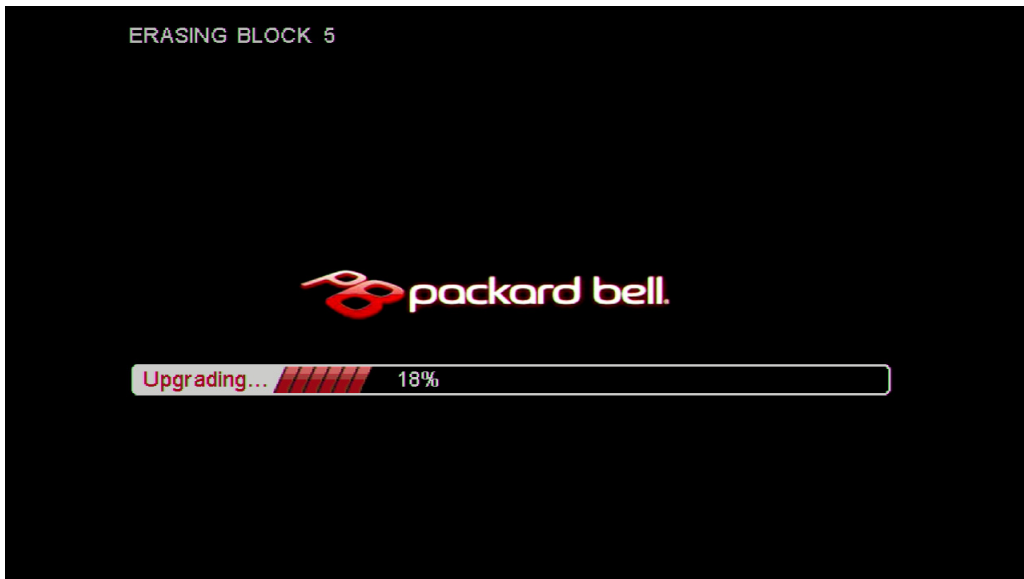

6. Press **POWER** key on the remote control to power on the system.
7. After the system is boot up, go to "**SETTINGS-->PREFERENCES**". Use the navigation key to highlight **Default**. Press **RIGHT** key to highlight **RESET** and then press **ENTER** key to process factory reset. This completes firmware upgrade.



Connector Locations and Board Layout

Main Board Layout

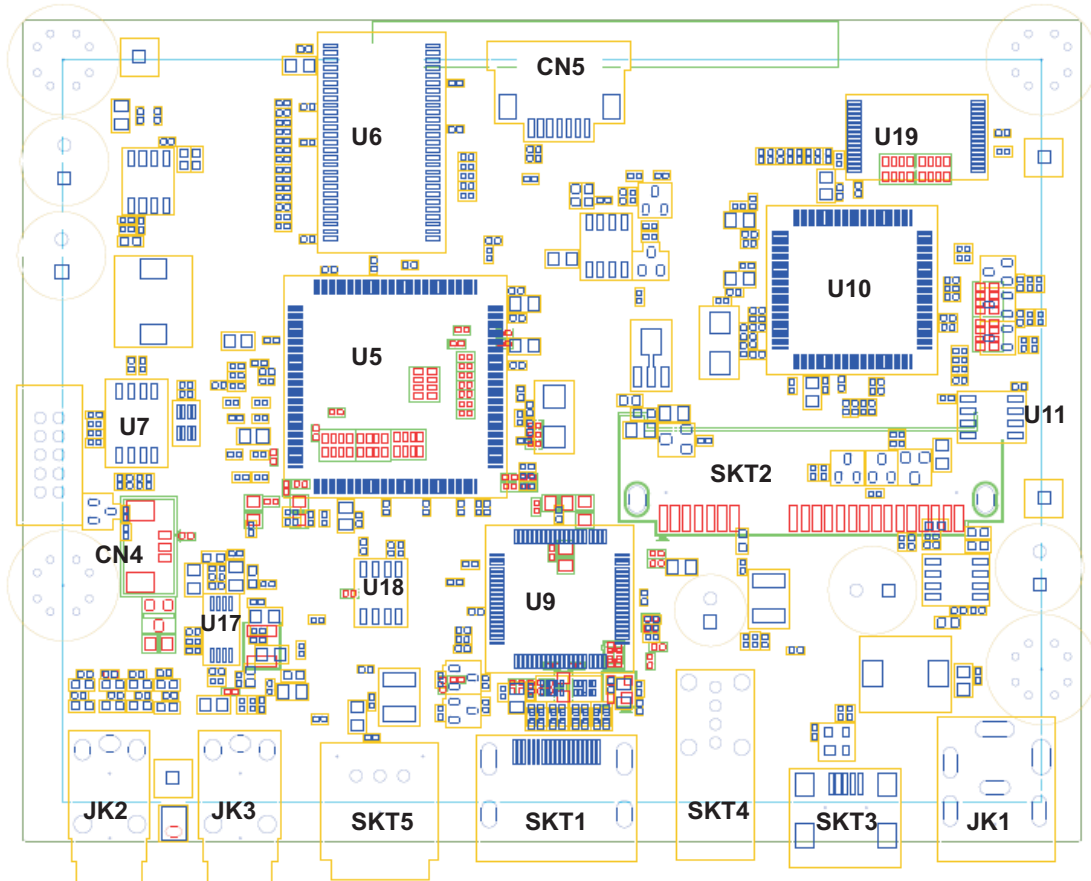

Item	Description	Item	Description
U5	Processor ES6461SAB	JK2	component video
U6	SDRAM NT5SV8M16FS-6K	JK3	composite video+ audio L/R
U7	Flash MX25L1605DM	SKT1	HDMI connector
U9	Scaler ES7109S	SKT3	Mini-USB connector
U10	Controller GL830-MX	SKT4	USB A Type
U11	EEPROM AT93C46DN	SKT5	SPDIF optical connector
U17	Audio amplifier MC4558C	SKT2	SATA connector
U18	EEPROM AT24C02BN	CN4	Fan connector
U19	Flash SST39VF010	CN5	IR board connector
JK1	12V DC Jack		

Rear I/O Connectors

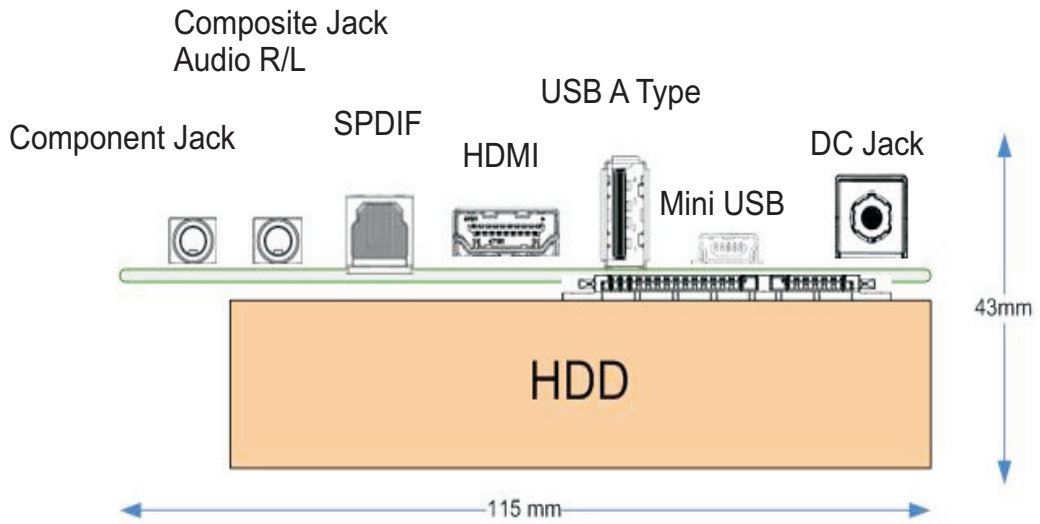

IR Board Placement

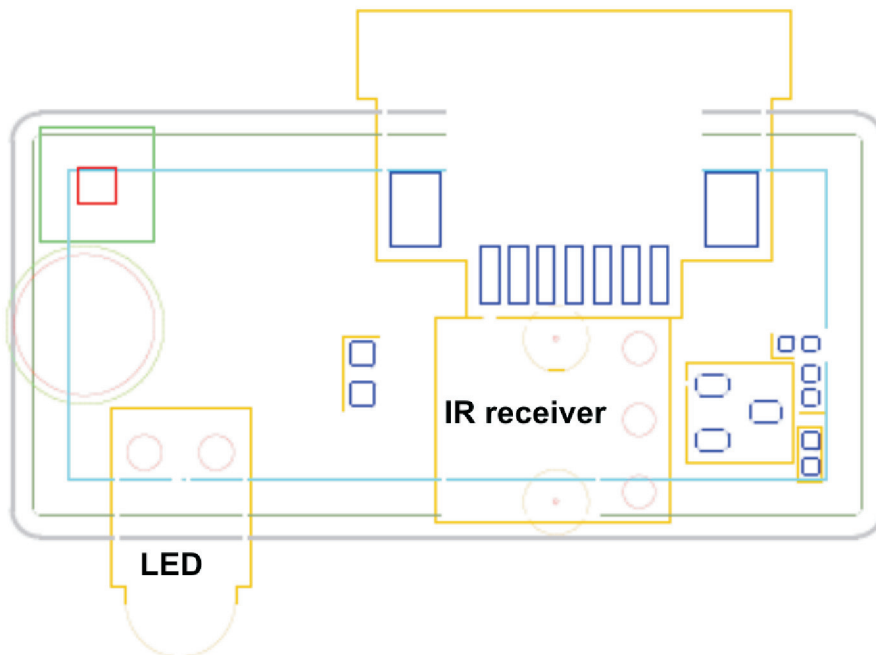

FRU (Field Replaceable Unit) List



This chapter gives you the FRU (Field Replaceable Unit) listing in global configurations of Studio MMP3400. Refer to this chapter whenever ordering for parts to repair or for RMA (Return Merchandise Authorization).

Please note that WHEN ORDERING FRU PARTS, you should check the most up-to-date information available on your regional web or channel. For whatever reasons a part number change is made, it will not be noted on the printed Service Guide. For ACER AUTHORIZED SERVICE PROVIDERS, your Acer office may have a DIFFERENT part number code from those given in the FRU list of this printed Service Guide. You MUST use the local FRU list provided by your regional Acer office to order FRU parts for repair and service of customer machines.

To scrap or to return the defective parts, you should follow the local government ordinance or regulations on how to dispose it properly, or follow the rules set by your regional Acer office on how to return it.

Pictures	Part Name	Description	OEM Part No.
	REMOTE CONTROLLER 2T1-32	REMOTE CONTROL 2T1-32	25.T1901.001
	ADAPTER 24W 12V APD WA-24E12G-AMA EU	ADP 24W 12V WA-24E12G-AMA EU	AP.02409.001
	IR BOARD	PE661L/MMP3400 IR BOARD -1(DIP)	55.T1901.001
	EXTERNAL MINI USB CABLE 600MM	C.A MINI USB TO USB CABLE	50.T1901.002
	AUDIO CABLE 1M PHONE JACK WITH COMPOSITE	C.A PHONE JACK WITH COMPOSITE	50.T1901.003
	VEDIO CABLE 1M PHONE JACK WITH COMPONENT	C.A PHONE JACK WITH COMPONENT	50.T1901.004

	HDMI CABLE 1.5M	C.A HDMI CABLE WITH 1.5M	50.T1901.005
	IR BAORD CABLE	C.A. P7 C2 L170	50.T1901.001
	IR/LED HOLDER	HLDR LED MMP3400	42.T1901.001
	TOP COVER	ASSY TOP COVER MMP3400	60.T1901.002
	REAR COVER	ASSY BOTTOM COVER MMP3400	60.T1901.003
	TOP SHIELD BRACKET	BRKT TOP SHIELD MMP3400	33.T1901.001
	LOWER COVER	ASSY LOWER MMP3400	60.T1901.001
	FAN	BLOWER MMP3400 FORCECON	23.T1901.001
	FAN	BLOWER MMP3400 SUNON	23.T1901.001

	HDD 2TB 3.5" 5400RPM SATA WD GP500M WD20EADS-22R6B0 GP	HDD 2TB WD WD20EADS-22R6B0 GP	KH.02K08.001
	HDD 3.5" 1000GB 7200RPM SATA SEAGATE SEAGATE ST31000528AS LF	HDD 1TB SGT ST31000528AS 7.2KR	KH.01K01.007
	HDD 1TB 3.5" 7200RPM SATA HGST SATURN HDT721010SLA360	HDD 1TB HGST HDT721010SLA360	KH.01K07.002
	HDD 1TB 3.5" 5400RPM SATAII WD10EADS-22M4B0 8MB GP	HDD 1TB WD10EADS-22M2B0 GP	KH.01K08.005
	HDD 1.5TB 3.5" 7200RPM SATA SEAGATE BRINKS ST31500341AS 32MB CC4H 7	HDD 1.5TB SGT ST31500341AS 7.2	KH.15K01.002
	HDD 320GB 3.5" 7200RPM SATA II SEAGATE PHARAOH 8MB NCQ	HDD 320GB 3.5" SEAGATE PHARAOH	KH.32001.015
	HDD 320GB 3.5" 7200RPM SATA II 8MB HGST HDT721032SLA380 SATURN	HDD 320GB HGST HDT721032SLA380	KH.32007.006
	HDD 3.5" 500GB 7200RPM SATA SEAGATE PHARAOH ST3500418AS	HDD 500GB SGT ST3500418AS 7.2K	KH.50001.012
	HDD 500GB 3.5" 7200RPM 8MB SATA HGST HDT721050SLA360	HDD 500GB HGST HDT721050SLA360	KH.50007.008
	HDD 3.5" 500GB 7200RPM SATA WD XL320M WD5000AAKS-22M9A0	HDD 500GB WD WD5000AAKS-22M9A0	KH.50008.014
	HDD 640GB 3.5" 7200RPM HGST HDT721064SLA360 SATURN SATA	HDD 640GB HGST HDT721064SLA360	KH.64007.001
	HDD 750GB 3.5" 7200RPM SATA II SEAGATE PHARAOH ST3750528AS	HDD 750GB SGT ST3750528AS 7.2K	KH.75001.008
	HDD 750GB HGST 3.5" 7200RPM SATURN SATA HDT721075SLA360	HDD 750GB HGST HDT721075SLA360	KH.75007.002
	MAINBOARD ESS6461 SAB ES7109 FOR MMP3400	PE661L/MMP3400 MB -1 DIP	MB.T1901.001
	FOOT RUBBER	RUB FOOT MMP3400	47.T1901.001
	SCREW MACH WAFER NYLOK COARSE M2*L5 NI	SCREW MACH WAFER M2*L5 NI	86.9A552.5R0
	SCREW FLAT M3*L4 NI	SCRW FLAT M3*L4 NI	86.5A534.4R0
	SCREW M2.6X8	SCRW M2.6X8	86.SA33Q.8R0
	SCREW WAFER #6-32 L6 NI	SCREW WAFER #6-32 L6 NI	86.9A532.6R0

A

appearance 4

B

block diagram 3

D

disassembly process 8

Disassembly Requirements 7

F

Features 1

field replaceable unit list 29

I

ir board placement 28

M

main board layout 27

Main screw list 8

R

rear i/o connectors 28

reassembly process 16

remote control 5

S

System

Block Diagram 3

System block diagram

UMA 3

T

Troubleshooting 25

V

view

left 5

Free Manuals Download Website

<http://myh66.com>

<http://usermanuals.us>

<http://www.somanuals.com>

<http://www.4manuals.cc>

<http://www.manual-lib.com>

<http://www.404manual.com>

<http://www.luxmanual.com>

<http://aubethermostatmanual.com>

Golf course search by state

<http://golfingnear.com>

Email search by domain

<http://emailbydomain.com>

Auto manuals search

<http://auto.somanuals.com>

TV manuals search

<http://tv.somanuals.com>