



Acer B203W
Service Guide

Copyright

Copyright © 2003 by Acer Incorporated. All rights reserved. No part of this publication may be reproduced, Transmitted, transcribed, stored in a retrieval system, or translated into any language or computer language, in any form or by any means, electronic, mechanical, magnetic, optical, chemical, manual or otherwise, without the prior written permission of Acer Incorporated.

Disclaimer

The information in this guide is subject to change without notice. Acer Incorporated makes no representations or warranties, either expressed or implied, with respect to the contents hereof and specifically disclaims any warranties of merchantability or fitness for any particular purpose. Any Acer Incorporated software described in this manual is sold or licensed "as is". Should the programs prove defective following their purchase, the buyer (and not Acer Incorporated, its distributor, or its dealer) assumes the entire cost of all necessary servicing, repair, and any incidental or consequential damages resulting from any defect in the software.

Intel is a registered trademark of Intel Corporation.

Pentium and Pentium II/III are trademarks of Intel Corporation.

Other brand and product names are trademarks and/or registered trademarks of their respective holders.

Trademarks

Acer is a registered trademark of Acer Incorporated.

All other trademarks are property of their respective owners.

Conventions

The following conventions are used in this manual:

| | |
|-----------------|--|
| Screen messages | Denotes actual messages that appear on screen. |
| Note | Gives bits and pieces of additional information related to the current topic. |
| Warning | Alerts you to any damage that might result from doing or not doing specific actions. |
| Caution | Gives precautionary measures to avoid possible hardware or software problems. |
| Important | Remind you to do specific actions relevant to the accomplishment of procedures. |

Preface

Before using this information and the product it supports, please read the following general information.

1. This Service Guide provides you with all technical information relating to the BASIC CONFIGURATION decided for Acer's "global" product offering. To better fit local market requirements and enhance product competitiveness, your regional office may have decided to extend the functionality of a machine (e.g. add-on card, modem, or extra memory capability). These LOCALIZED FEATURES will NOT be covered in this generic service guide. In such cases, please contact your regional offices or the responsible personnel/channel to provide you with further technical details.
2. Please note WHEN ORDERING FRU PARTS, that you should check the most up-to-date information available on your regional web or channel. If, for whatever reason, a part number change is made, it will not be noted in the printed Service Guide. For ACER-AUTHORIZED SERVICE PROVIDERS, your Acer office may have a DIFFERENT part number code to those given in the FRU list of this printed Service Guide. You MUST use the list provided by your regional Acer office to order FRU parts for repair and service of customer machines.

Warning: (For FCC Certified Models)

Note: This equipment has been tested and found to comply with the limits for a Class B digital device, pursuant to Part 15 of the FCC Rules. These limits are designed to provide reasonable protection against harmful interference in a residential installation. This equipment generates, uses and can radiate radio frequency energy, and if not installed and used in accordance with the instructions, may cause harmful interference to radio communications. However, there is no guarantee that interference will not occur in a particular installation. If this equipment does cause harmful interference to radio or television reception, which can be determined by turning the equipment off and on, the user is encouraged to try to correct the interference by one or more of the following measures:

1. Reorient or relocate the receiving antenna.
2. Increase the separation between the equipment and receiver.
3. Connect the equipment into an outlet on a circuit different from that to which the receiver is connected.
4. Consult the dealer or an experienced radio/TV technician for help.

Notice:

1. The changes or modifications not expressly approved by the party responsible for compliance could void the user's authority to operate the equipment.
2. Shielded interface cables and AC power cord, if any, must be used in order to comply with the emission limits.
3. The manufacturer is not responsible for any radio or TV interference caused by unauthorized modification to this equipment. It is the responsibility of the user to correct such interference.

As ENERGY STAR® Partner our company has determined that this product meets the ENERGY STAR® guidelines for energy efficiency.

Warning:

To prevent fire or shock hazard, do not expose the monitor to rain or moisture. Dangerous high voltages are present inside the monitor. Do not open the cabinet. Refer servicing to qualified personnel only.

Precautions

- Do not use the monitor near water, e.g. near a bathtub, washbowl, kitchen sink, laundry tub, swimming pool or in a wet basement.
- Do not place the monitor on an unstable trolley, stand, or table. If the monitor falls, it can injure a person and cause serious damage to the appliance. Use only a trolley or stand recommended by the manufacturer or sold with the monitor. If you mount the monitor on a wall or shelf, use a mounting kit approved by the manufacturer and follow the kit instructions.
- Slots and openings in the back and bottom of the cabinet are provided for ventilation. To ensure reliable operation of the monitor and to protect it from overheating, be sure these openings are not blocked or covered. Do not place the monitor on a bed, sofa, rug, or similar surface. Do not place the monitor near or over a radiator or heat register. Do not place the monitor in a bookcase or cabinet unless proper ventilation is provided.
- The monitor should be operated only from the type of power source indicated on the label. If you are not sure of the type of power supplied to your home, consult your dealer or local power company.
- The monitor is equipped with a three-pronged grounded plug, a plug with a third (grounding) pin. This plug will fit only into a grounded power outlet as a safety feature. If your outlet does not accommodate the three-wire plug, have an electrician install the correct outlet, or use an adapter to ground the appliance safely. Do not defeat the safety purpose of the grounded plug.
- Unplug the unit during a lightning storm or when it will not be used for long periods of time. This will protect the monitor from damage due to power surges.
- Do not overload power strips and extension cords. Overloading can result in fire or electric shock.
- Never push any object into the slot on the monitor cabinet. It could short circuit parts causing a fire or electric shock. Never spill liquids on the monitor.
- Do not attempt to service the monitor yourself; opening or removing covers can expose you to dangerous voltages and other hazards. Please refer all servicing to qualified service personnel
- To ensure satisfactory operation, use the monitor only with UL listed computers which have appropriate configured receptacles marked between 100 - 240V AC, Min. 5A.
- The wall socket shall be installed near the equipment and shall be easily accessible.

Special Notes On LCD Monitors

The following symptoms are normal with LCD monitor and do not indicate a problem.

Notes

- Due to the nature of the fluorescent light, the screen may flicker during initial use. Turn off the Power Switch and then turn it on again to make sure the flicker disappears.
- You may find slightly uneven brightness on the screen depending on the desktop pattern you use.
- The LCD screen has effective pixels of 99.99% or more. It may include blemishes of 0.01% or less such as a missing pixel or a pixel lit all of the time.
- Due to the nature of the LCD screen, an afterimage of the previous screen may remain after switching the image, when the same image is displayed for hours. In this case, the screen is recovered slowly by changing the image or turning off the Power Switch for hours.

Table Of Contents

| | | |
|------------------|--|-----------|
| Chapter 1 | Monitor Features | 7 |
| | Introduction | 7 |
| | Electrical Requirements | 8 |
| | LCD Monitor General Specification | 9 |
| | LCD Panel Specification | 10 |
| | Support Timing | 13 |
| | Monitor Block Diagram | 14 |
| | Main Board Diagram | 15 |
| | Software Flow chart | 16 |
| | Main Board Layout | 18 |
| | Installation | 19 |
| | Attaching/Removing the base | 20 |
| Chapter 2 | Operating Instructions | 22 |
| | External Controls | 22 |
| | Front Panel Controls | 22 |
| | eColor Management (OSD) | 23 |
| | How to Adjust a Setting | 24 |
| | LOGO | 27 |
| Chapter 3 | Machine Disassembly | 28 |
| Chapter 4 | Troubleshooting | 31 |
| Chapter 5 | Connector Information | 37 |
| Chapter 6 | FRU (Field Replacement Unit) List | 38 |
| | Exploded Diagram | 38 |
| Chapter 7 | Schematic Diagram | 41 |

Introduction**Scope**

This specification defines the requirements for the 20" MICROPROCESSOR based Multi-mode supported high resolution color LCD monitor. This monitor can be directly connected to general 15-pin D-sub VGA connector and 24 pin DVI connector, also supports VESA DPMS power management and plug & play function.

Description

The LCD monitor is designed with the latest LCD technology to provide a performance oriented product with no radiation. This will alleviate the growing health concerns. It is also a space saving design, allowing more desktop space, and comparing to the traditional CRT monitor, it consumes less power and gets less weight in addition MTBF target is 50k hours or more.

Chart of B203W

| | |
|------------------------|---|
| Panel | M201EW02 V80C SZ AUO |
| Signal Interface | D-Sub 15-pin/DVI 24-pin |
| Sync Type | Separate / Compatible |
| Color Temp User Adjust | Support |
| DDC | DDC2B |
| Speaker | TA7AM6D8W7AYDN(Yes) TA7AM6D8W7AYHN(No) |
| Headphone Jack | TA7AM6D8W7AYDN(Yes) TA7AM6D8W7AYHN(No) |
| Microphone Jack | No |
| USB Hub | Not support |
| Tilt / Swivel | Yes / Yes |

Electrical Requirements

Standard Test Conditions

All tests shall be performed under the following conditions, unless otherwise specified.

| | |
|---------------------------|---|
| Ambient light | Dark room (< 1 cd/m ²) |
| Viewing distance | 40 cm for LCD performance, 20 cm for LCD failures |
| Warm up time | >30 minutes |
| Analog Input signal | 700 mVss |
| Control temperature | 6500° K (e-Color set to "User" mode) |
| Brightness control | The value under user mode |
| User contrast control | Set to The value under user mode, which allows that the brightest two of 32 linear distributed gray-scales (0~ 700mv) can be distinguished. |
| Picture position and size | Factory preset value |
| Viewing angle | 90 ° H and V |
| AC Supply voltage | 230V± 5%, 50±3Hz |
| Ambient temperature | 20+5°C |
| Humidity | 65% ± 20% |
| Display mode | 1680x1050, 60 Hz, all white |
| e-color mode | Set to "User" mode |

Measurement systems

The units of measure stated in this document are listed below:

1 gamma = 1 nano tesla

1 tesla = 10,000 gauss

cm = in x 2.54

Lb = kg x 2.2

Degrees F = [°C x 1.8] + 32

Degrees C = [°F - 32]/1.8

$u' = 4x/(-2x + 12y + 3)$

$v' = 9y/(-2x + 12y + 3)$

$x = (27u'/4)/[(9u'/2) - 12v' + 9]$

$y = (3v')/[(9u'/2) - 12v' + 9]$

nits = cd/(m²) = Ft-L x 3.426

lux = foot-candle x 10.76

LCD Monitor General Specification

| | | |
|------------------------------|---|-----------------------------|
| LCD Panel | Driving system | TFT Color LCD |
| | Active Display Area | 433.41(H) x 270.90(V) |
| | Pixel pitch | 0.258(H) x 0.258(W) |
| | Contrast Ratio | 1000 : 1 |
| | Response time | 5ms |
| | Luminance of White | 300(Type) cd/m ² |
| Input | Separate Sync. | H/V TTL |
| | H-Frequency | 30kHz – 83kHz |
| | V-Frequency | 56-75Hz |
| Viewing angle | CR=10: H:170 / V:170 (type) ; CR=5: H:176 / V:176 (type) | |
| Display Colors | 16.7M | |
| Display mode | 1680 x 1050 @60Hz | |
| EPA ENERGY STAR® | ON Mode | < 49W |
| | OFF Mode | < 1W |
| Contrast control | Set to The value under user mode, which allows that the brightest two of 32 linear distributed gray-scales (0~ 700mv) can be distinguished. | |
| Power Source | 90 V ~ 240 V, 50 ± 3Hz, 60 ± 3Hz | |
| Environmental Considerations | Operating Temp: 0° to 40°C Storage Temp: -30° to 65°C Operating Humidity: 0% to 90% Storage Humidity: 0% to 90% | |
| Peak surge current | < 100 A peak at 230 VAC and cold starting&25°C & DC Output at Full-load | |
| Power line surge | No advance effects (no loss of information or defect) with a maximum of 1 half-wave missing per second | |

LCD Panel Specification

This specification applies to the 20.1 inch-wide Color TFT-LCD Module M201EW02.

The display supports the WSXGA+ (1680(H) x 1050(V)) screen format and 16.7M colors (RGB 6-bits+Hi-RFC data).

All input signals are 2 Channel LVDS interface compatible. This module does not contain an inverter card for backlight.

General Specifications

| ITEMS | Unit | SPECIFICATIONS |
|--|----------------------|---|
| Screen Diagonal | [mm] | 511.13 (20.1" Wide) |
| Active Area | [mm] | 433.44 (H) x 270.90 (V) |
| Pixels H x V | | 1680(x3) x 1050 |
| Pixel Pitch | [mm] | 0.258 (per one triad) x 0.258 |
| Pixel Arrangement | | R.G.B. Vertical Stripe |
| Display Mode | | Normally White |
| White Luminance (Center) | [cd/m ²] | 300cd/m ² @ 7.5mA (Typ) |
| Contrast Ratio | | 1000:1 |
| Optical Response Time | [msec] | 5 (Typ, on/off) |
| Nominal Input Voltage VCC | [Volt] | +5.0 V |
| Power Consumption (VCC line + CCFL line) | [Watt] | 27.7 |
| Weight | [Grams] | 2010 (Typ) |
| Physical Size | [mm] | 459.4(W) x 296.4(H) x 16.6(D) (Typ) |
| Electrical Interface | | Dual Channel LVDS |
| Support Color | | 16.7M colors (RGB 6-bits+Hi-RFC data) |
| Temperature Range | | |
| Operating | [°C] | 0 to +50 |
| Storage (Shipping) | [°C] | -20 to +60 |
| Surface Treatment | | Hard-coating (3H), Anti-Glare treatment |
| RoHS | | RoHS compliance |

Functional Block Diagram

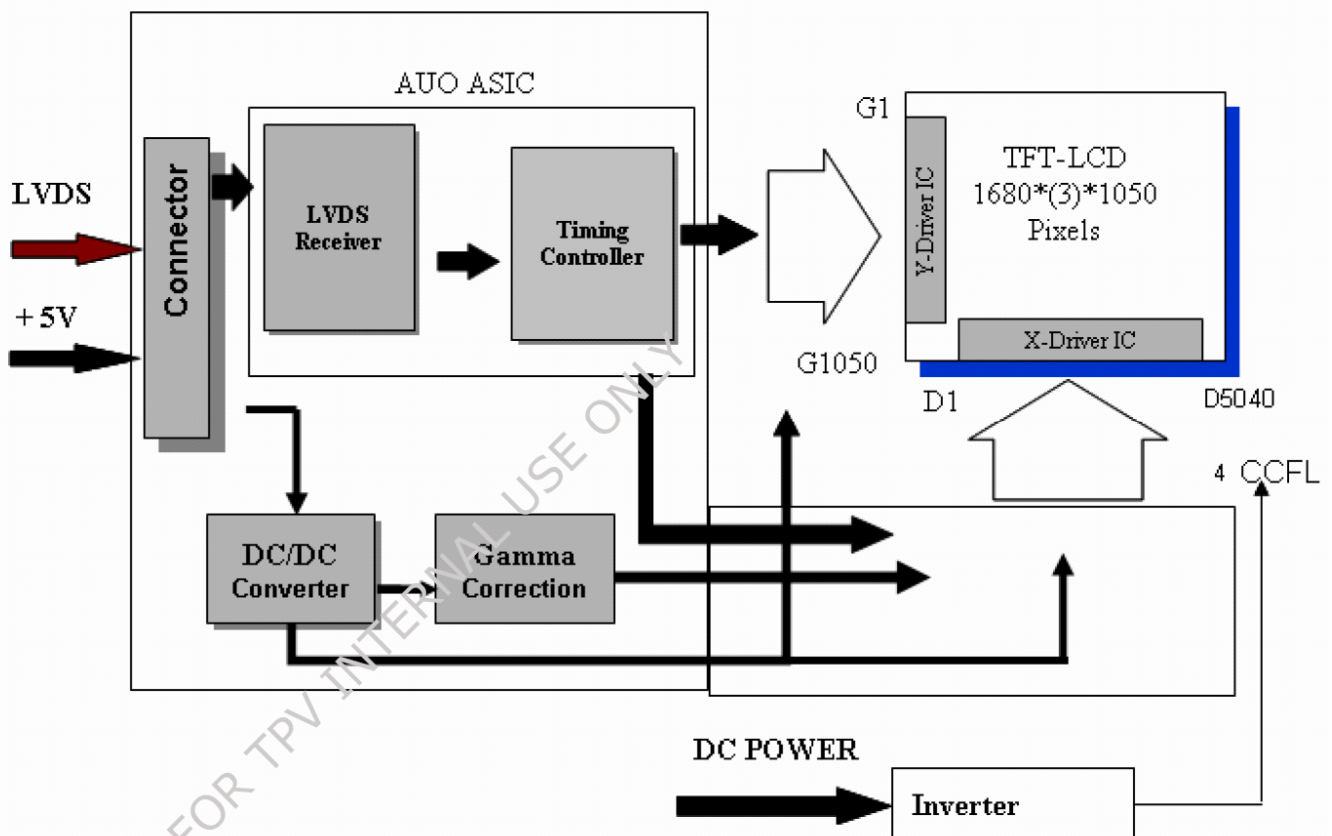

Electrical Characteristics

TFT LCD Module—Power Specification

| Symbol | Parameter | Min | Typ | Max | Units | Condition |
|--------|-------------------------|-----|-----|-----|--------|-------------------------------------|
| VCC | Logic/LCD Drive Voltage | 4.5 | 5 | 5.5 | [Volt] | ±10% |
| ICC | VCC current | - | 1.1 | 1.5 | [A] | Vin=5V , All Black Pattern, at 60Hz |
| Irush | LCD Inrush Current | - | - | 3 | [A] | Note |
| PCC | VCC Power | - | 5.5 | 7.5 | [Watt] | Vin=5V , All Black Pattern, at 60Hz |

Backlight Unit

| Symbol | Parameter | Min. | Typ. | Max. | Unit |
|----------------|--|---------------|---------------|---------------|---------------|
| ISCFL | CCFL standard current | 7 | 7.5 | 8 | [mA] rms |
| IRCFL | CCFL operation range | 3 | 7.5 | 8 | [mA] rms |
| FCFL | CCFL Frequency | 40 | 55 | 60 | [KHz] |
| ViCFL (0°C) | CCFL Ignition Voltage (End of the lamp wire connector) | 1700 | - | - | [Volt] rms |
| ViCF (25°C) | CCFL Ignition Voltage (End of the lamp wire connector) | 1300 | - | - | [Volt] rms |
| VCFL | CCFL Operation Voltage | 666 @7.5mA | 750 @7.5mA | 814 @7.5mA | [Volt] rms |
| PCFL | CCFL Power consumption (for reference) | - | 22.2 | - | [Watt] |
| LTCFL | CCFL life Time | 50,000 | 55,000 | - | [Hour] |

Optical Specifications

| Item | Unit | Conditions | Min. | Typ. | Max. | Note |
|---|----------------------|--------------------|-------|-------|-------|------|
| Viewing Angle | [degree] | Horizontal (Right) | 70 | 80 | - | 1 |
| | [degree] | CR = 10 (Left) | 70 | 80 | - | |
| | [degree] | Vertical (Up) | 70 | 80 | - | |
| | [degree] | CR = 10 (Down) | 70 | 80 | - | |
| Luminance Uniformity | [%] | | 75 | 80 | - | 2,3 |
| Response Time | [msec] | Rising Time | - | 3.6 | 5.7 | 4,6 |
| | [msec] | Falling Time | - | 1.4 | 2.3 | |
| | [msec] | Rising + Falling | - | 5.0 | 8.0 | |
| Color / Chromaticity Coordinates (CIE 1931) | | Red x | 0.619 | 0.649 | 0.679 | 4 |
| | | Red y | 0.308 | 0.338 | 0.368 | |
| | | Green x | 0.259 | 0.289 | 0.319 | |
| | | Green y | 0.579 | 0.609 | 0.639 | |
| | | Blue x | 0.116 | 0.146 | 0.176 | |
| | | Blue y | 0.040 | 0.070 | 0.100 | |
| | | White x | 0.283 | 0.313 | 0.343 | |
| | | White y | 0.299 | 0.329 | 0.359 | |
| White Luminance at CCFL 7.5mA (central point) | [cd/m ²] | | 240 | 300 | - | 4 |
| Contrast ratio | | Normal Direction | 800 | 1000 | - | 4 |
| Crosstalk (in75Hz) | [%] | | | | 1.5 | 5 |
| Flicker | [dB] | | | | -20 | 7 |

Support Timing

| Mode | Resolution | Total | Horizontal | | Vertical | | Nominal Pixel Clock (MHz) |
|--------|----------------|------------|------------------------------|---------------|------------------------|---------------|---------------------------|
| | | | Nominal Frequency +/- 0.5kHz | Sync Polarity | Nominal Freq. +/- 1 Hz | Sync Polarity | |
| VGA | 640x480@60Hz | 800 x 525 | 31.469 | N | 59.940 | N | 25.175 |
| | 640x480@72Hz | 832 x 520 | 37.861 | N | 72.809 | N | 31.500 |
| | 640x480@75Hz | 840 x 500 | 37.500 | N | 75.00 | N | 31.500 |
| SVGA | 800x600@56Hz | 1024 x 625 | 35.156 | N/P | 56.250 | N/P | 36.000 |
| | 800x600@60Hz | 1056 x 628 | 37.879 | P | 60.317 | P | 40.000 |
| | 800x600@72Hz | 1040 x 666 | 48.077 | P | 72.188 | P | 50.000 |
| | 800x600@75Hz | 1056x625 | 46.875 | P | 75.000 | P | 49.500 |
| XGA | 1024x768@60Hz | 1344x806 | 48.363 | N | 60.004 | N | 65.000 |
| | 1024x768@70Hz | 1328x806 | 56.476 | N | 70.069 | N | 75.000 |
| | 1024x768@75Hz | 1312x800 | 60.023 | P | 75.029 | P | 78.750 |
| VESA | 1152x864@75Hz | 1600X900 | 67.5kHz | P | 75 | P | 108.000 |
| SXGA | 1280x1024@60Hz | 1688x1066 | 63.981 | P | 60.020 | P | 108.000 |
| | 1280x1024@75Hz | 1688x1066 | 79.976 | P | 75.025 | P | 135.000 |
| | 1440x900@60Hz | 1904x934 | 55.93 | P | 60 | P | 106.5 |
| | 1440x900@75Hz | 1936x942 | 70.635 | P | 75 | N | 136.75 |
| UXGA | 1600x1200@60Hz | 2160x1250 | 75 | | 60 | | 162 |
| WSXGA+ | 1680x1050@60Hz | 2240x1089 | 65.29 | | 59.954 | | 146.25 |

Monitor Block Diagram

The LCD MONITOR will contain a main board, a power board, and key board which house the flat panel control logic, brightness control logic and DDC.

The power board will provide AC to DC Inverter voltage to drive the backlight of panel and the main board chips each voltage.

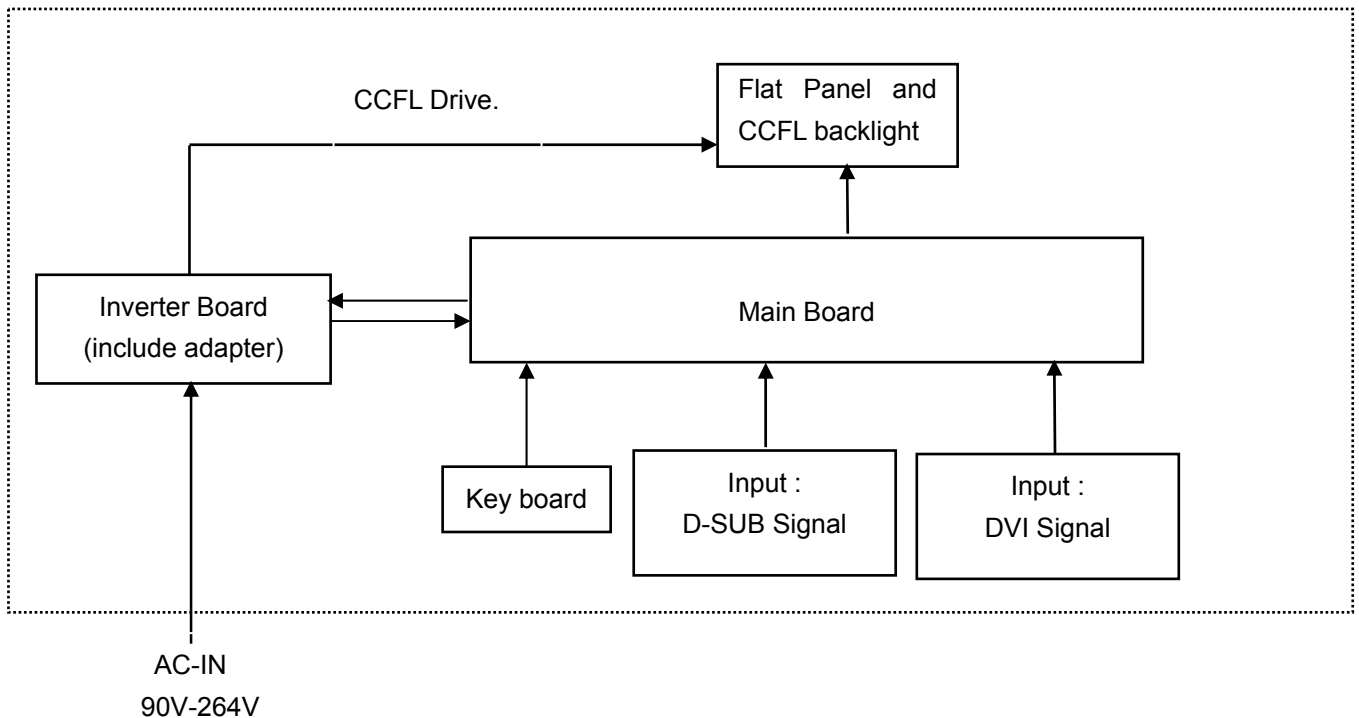

Main Board Diagram

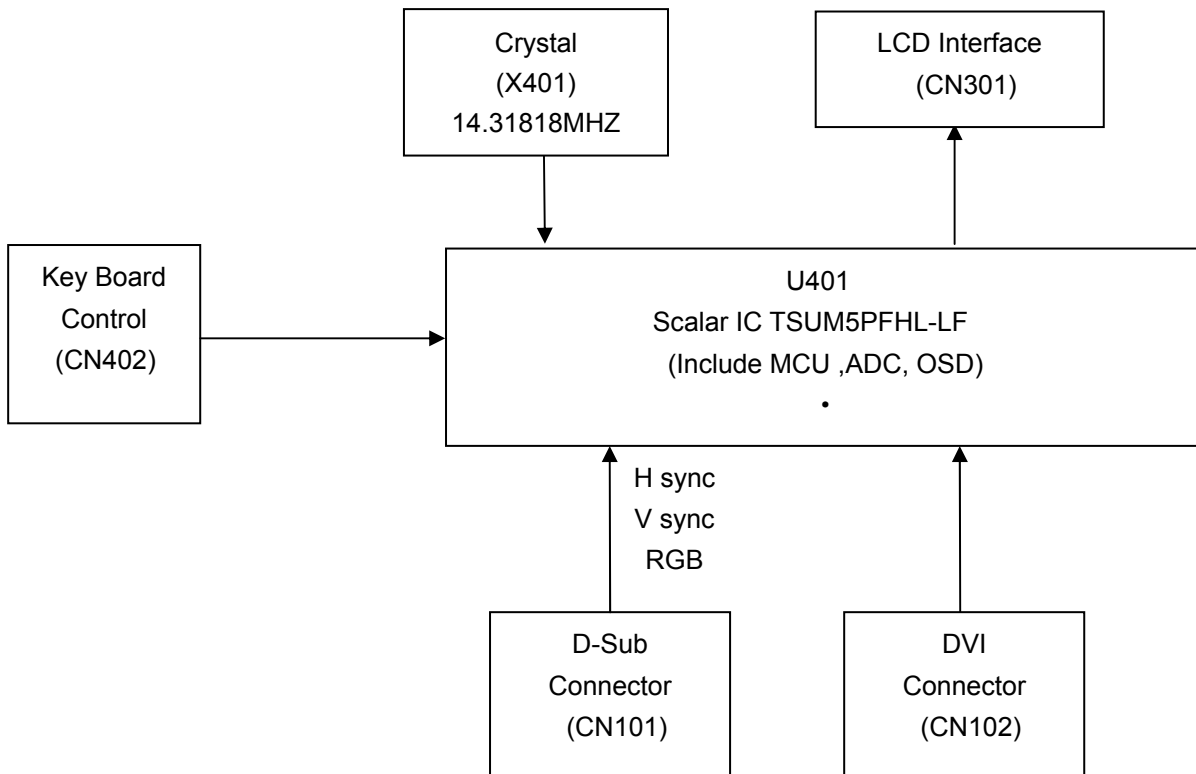

Software Flow Chart

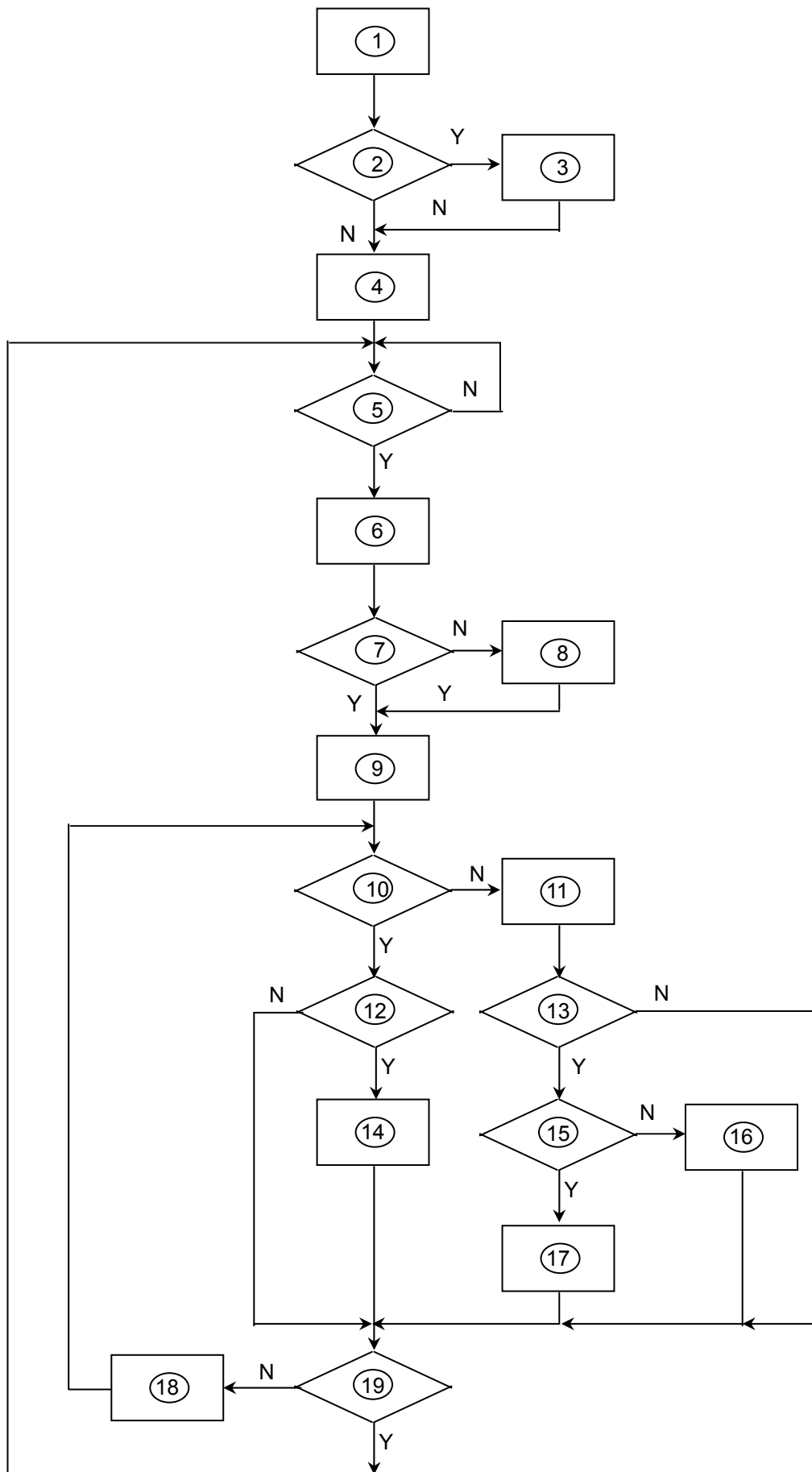

Remark:

| |
|--|
| 1) MCU initializes. |
| 2) Is the EEPROM blank? |
| 3) Program the EEPROM by default values. |
| 4) Get the PWM value of brightness from EEPROM. |
| 5) Is the power key pressed? |
| 6) Clear all global flags. |
| 7) Are the AUTO and SELECT keys pressed? |
| 8) Enter factory mode. |
| 9) Save the power key status into EEPROM. Turn on the LED and set it to green color. Scalar initializes. |
| 10) In standby mode? |
| 11) Update the lifetime of back light. |
| 12) Check the analog port, are there any signals coming? |
| 13) Does the scalar send out an interrupt request? |
| 14) Wake up the scalar. |
| 15) Are there any signals coming from analog port? |
| 16) Display "No connection Check Signal Cable" message. And go into standby mode after the message disappears. |
| 17) Program the scalar to be able to show the coming mode. |
| 18) Process the OSD display. |
| 19) Read the keyboard. Is the power key pressed? |

Main Board Layout

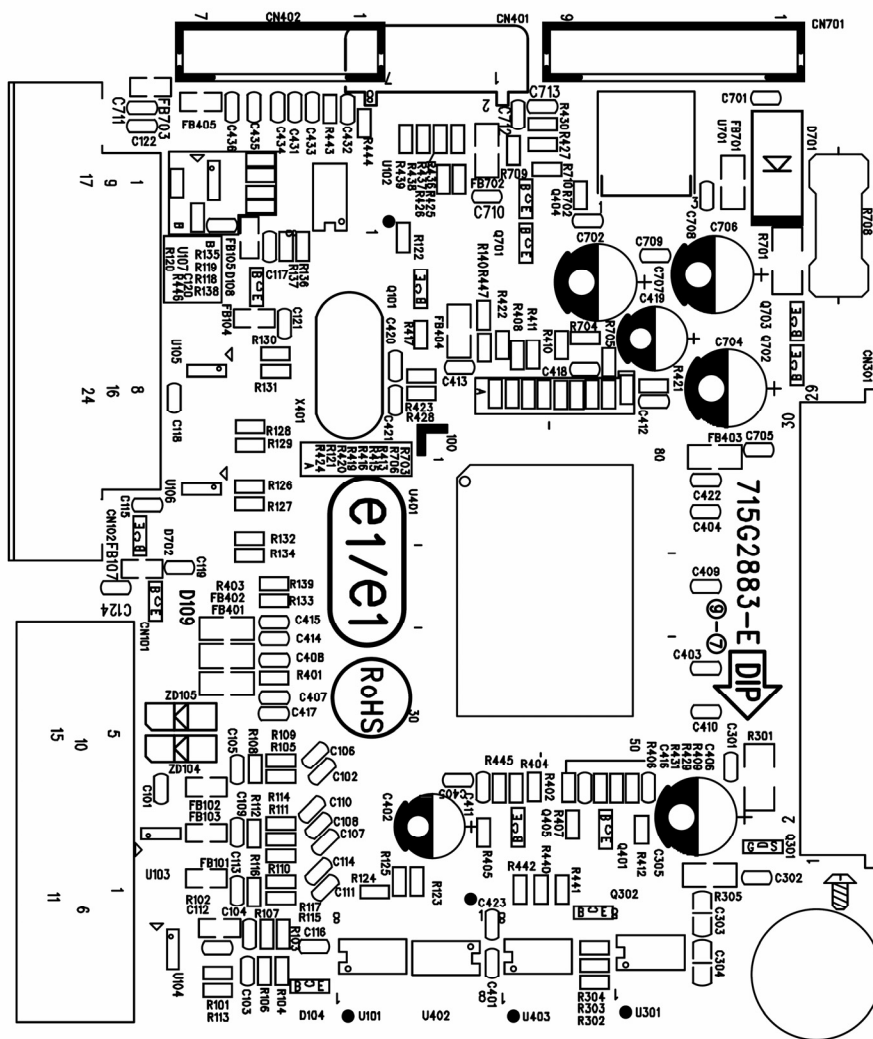

| Symbol | Description | Symbol | Description |
|--------|----------------------------|------------------------------|------------------------|
| CN402 | WAFER | CN102 | DVI 24PIN CONNECTOR |
| CN701 | WAFER 9P RIGHT ANELE PITCH | U103/U104/U105/ U106/U107 | IC AZC099-04S SOT23-6L |
| CN301 | CONNECTOR | U403 | IC M24C04-WMN6TP SO8 |
| CN101 | D-SUB 15PIN | U402 | SST25LF020A-33-4C-SAE |
| U401 | IC TSUM5PFHL-LF | U701 | AP1117E33LA |

Installation

To install the monitor on your host system, please follow the steps below:

Steps

1. Connect the video cable

A: Make sure both the monitor and computer are switched off.

B: Connect the VGA video cable to the computer.

C: Connect the digital cable (only for dual-input models).

(1) Make sure both the monitor and computer are switched off.

(2) Connect one end of the 24-pin DVI cable to the back of the monitor and the other end to the computer's port.

2. Connect the power cord

Connect the power cord to the monitor, then to a properly grounded AC outlet.

3. Turn on the monitor and computer

Turn on the monitor first, then the computer. This sequence is very important.

4. If the monitor does not function properly, please refer to the troubleshooting section to diagnose the problem.

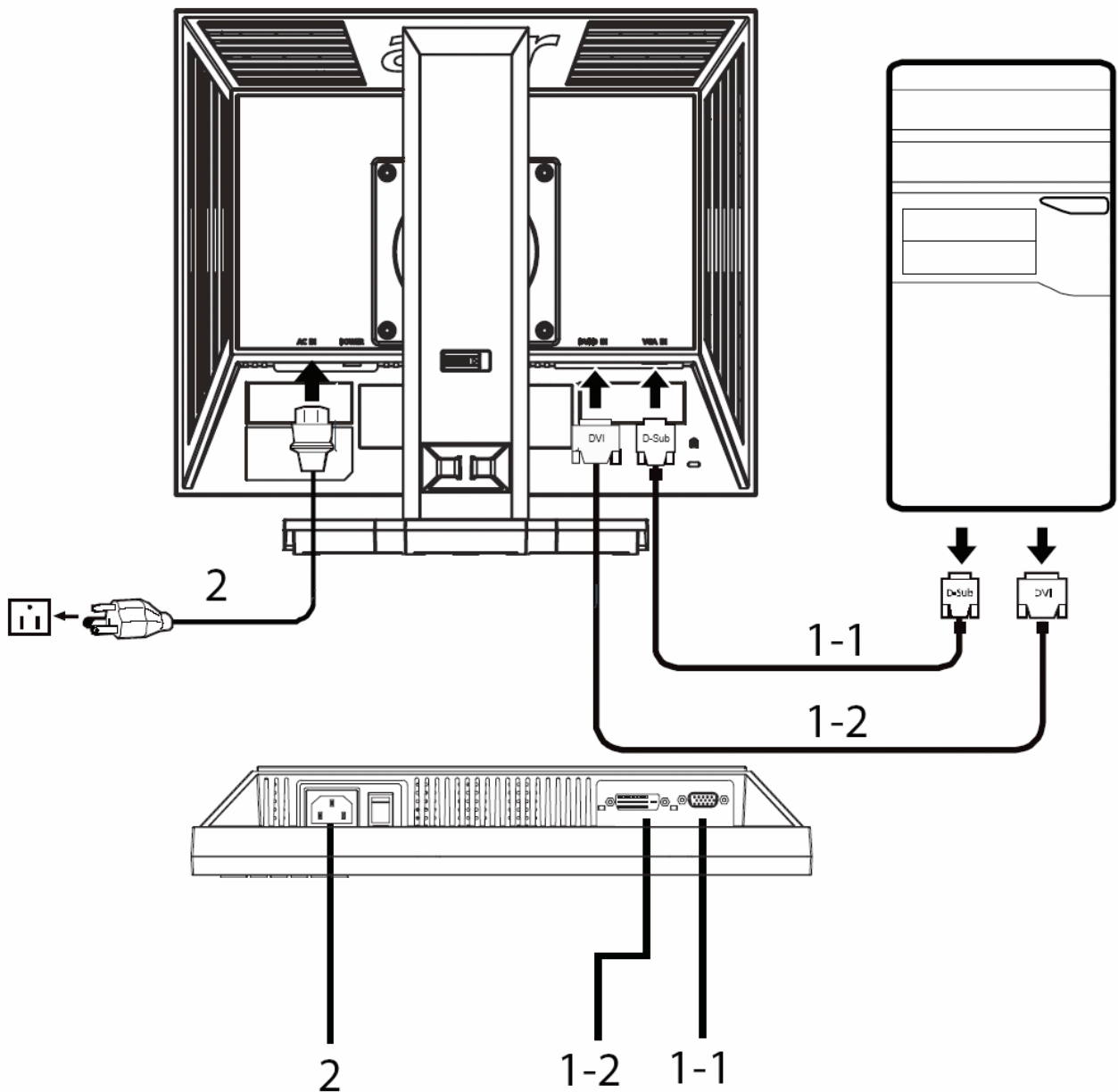

Attaching/Removing The Base

Install: Align the base with the stand and push the base towards the top of the monitor, and then rotate the base clockwise. Tighten the screw clockwise.

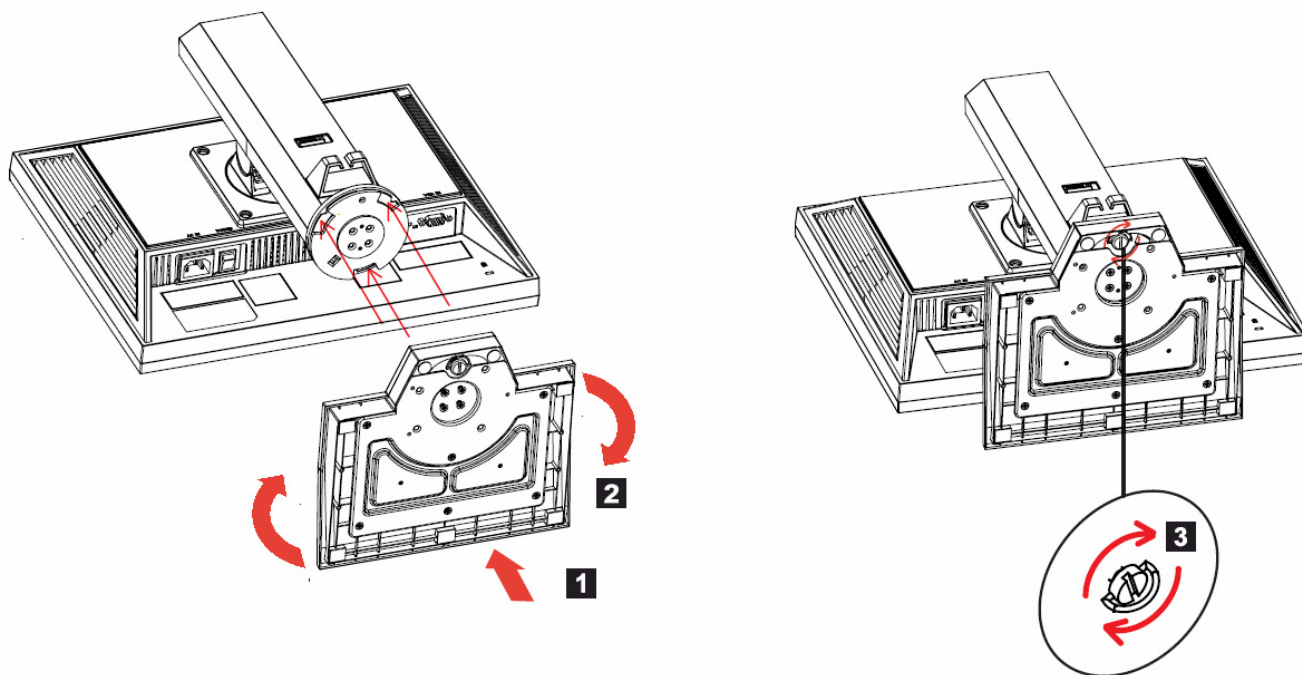

Remove: Reverse the steps to remove the base.

Screen Position Adjustment

In order to optimize the best viewing position, you can adjust the height/tilt/swivel/pivot of the monitor.

Height Adjustment

After pressing the top of the monitor, push the lock button towards right, then you can adjust the height of the monitor.

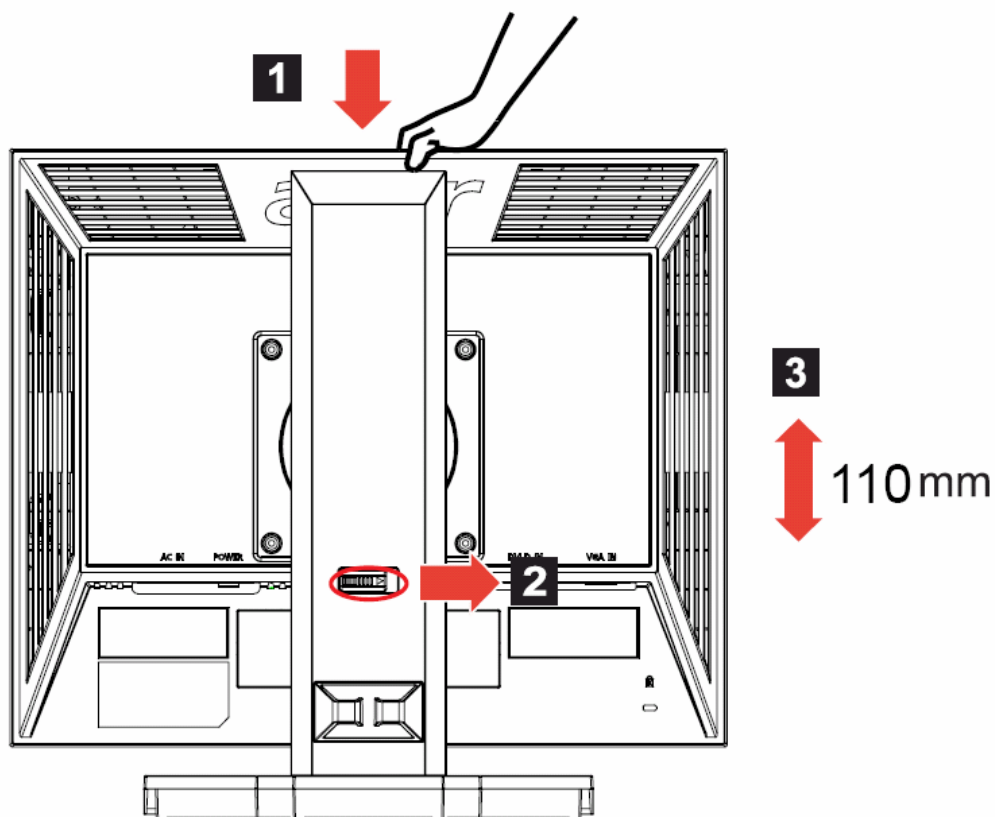

Tilt

Please see the illustration below for an example of the tilt range.

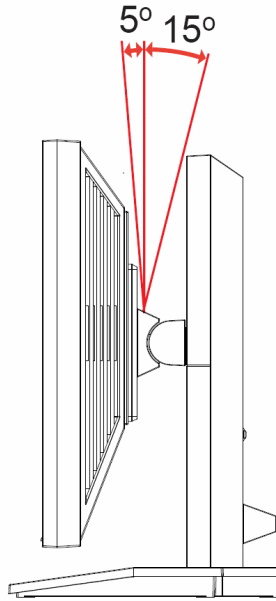

Swivel

With the built-in pedestal, you can swivel the monitor for the most comfortable viewing angle.

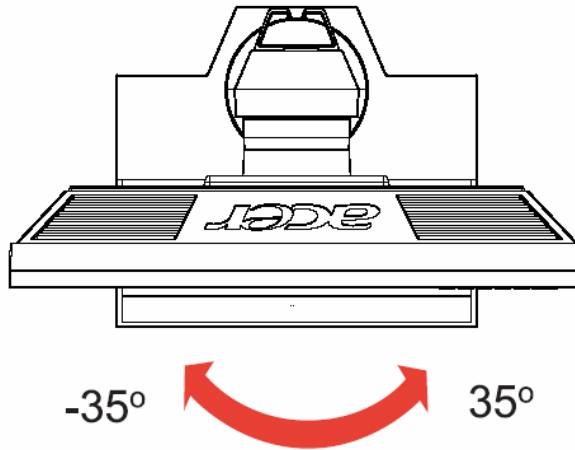

Monitor Pivot

Adjust height to the top position before rotation the monitor. Rotate clockwise until the monitor stops at 90° .

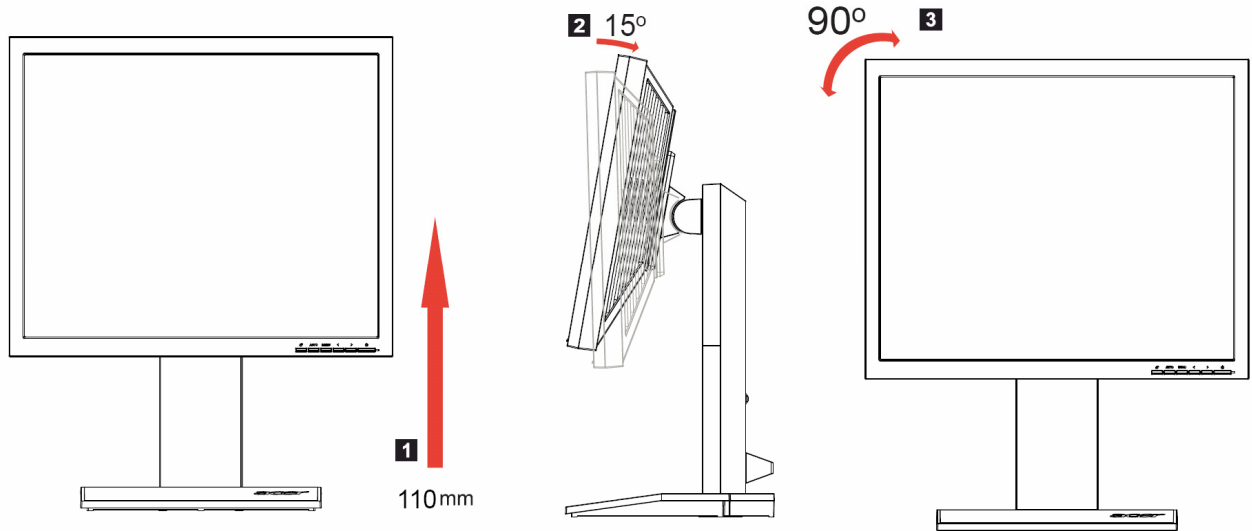

Press the power button to turn the monitor on or off. The other control buttons are located at front panel of the monitor. By changing these settings, the picture can be adjusted to your personal preferences.

- The power cord should be connected.
- Connect the video cable from the monitor to the video card.
- Press the power button to turn on the monitor position. The power indicator will light up.

External Controls

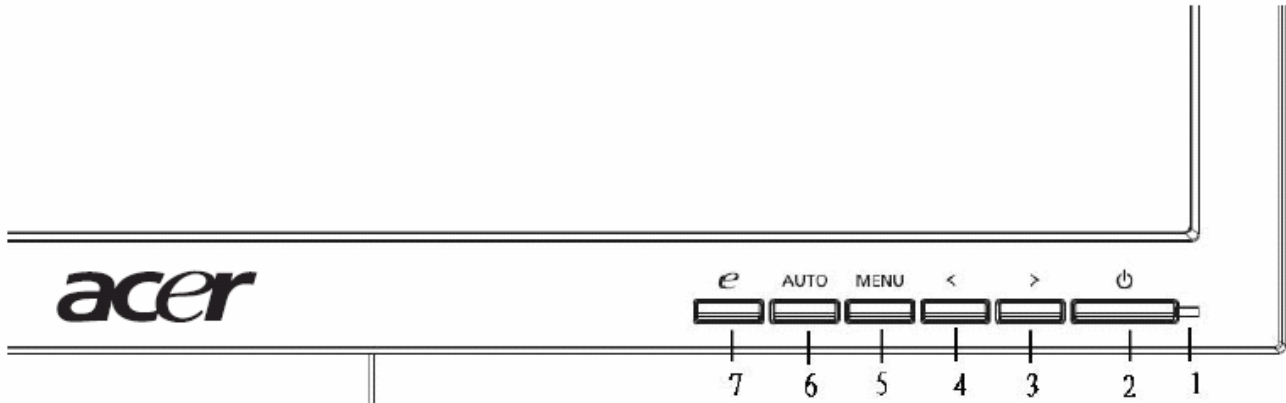

Front panel controls

1 Power LED: Lights up to indicate the power is turned on.

2 Power Switch: Turn the power on or off.

3.4 < / > : Press < or > to navigate to the desired function, press Enter to select the function. Press < or > to change the settings of the current function.

5 Menu/Enter: Activate the OSD menu when the OSD is off or activate deactivate the adjustment function when the OSD is on.

6 Auto adjust button/Exit:

a. When the OSD menu is active, this button will act as the exit key exit OSD menu).

b. When the OSD menu is inactive, press this button for two seconds to activate the Auto Adjustment function. The Auto Adjustment function s used to set the HPos, VPos, Clock and Focus.

7 Empowering Key/Exit:

a. When the OSD menu is active, this button will act as the exit key exit OSD menu).

b. When the OSD menu is inactive, press this button to select scenario mode.

eColor Management (OSD)

- Operation instructions
 - 1 Press the *e* Empowering Key to open the Acer eColor Management OSD and access the scenario modes.
 - 2 Press "<" or ">" to select the mode.
 - 3 Press the Auto-adjust button to confirm the mode and run Auto Adjust.

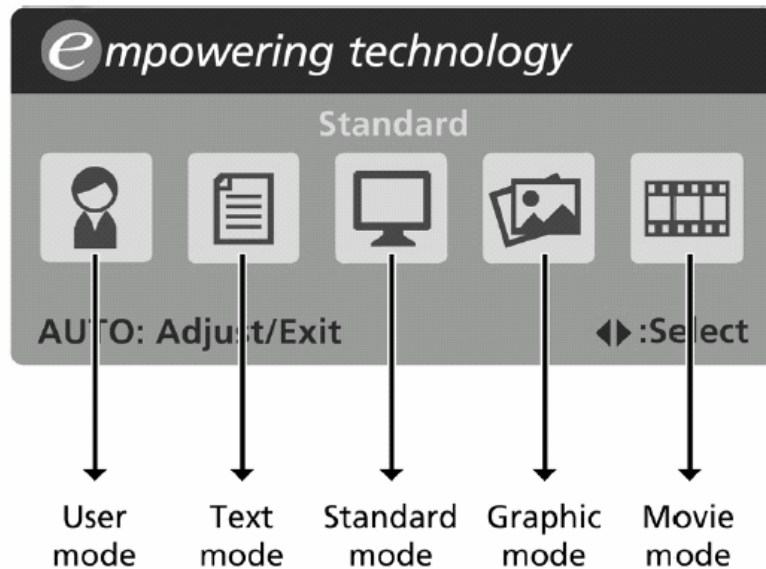

- Features and benefits

| Main menu icon | Sub menu item | Description |
|----------------|---------------|--|
| | User mode | User-defined. Settings can be fine-tuned to suit any situation. |
| | Text mode | Optimal balance of brightness and contrast to prevent eyestrain. The most comfortable way to read onscreen text. |
| | Standard mode | Default settings. Reflects native display capability. |
| | Graphic mode | Enhances colors and emphasizes fine detail. Pictures and photographs appear in vibrant colors with sharp detail. |
| | Movie mode | Displays scenes in clearest detail. Presents great visuals, even in unsuitably-lit environments. |

How to Adjust a Setting

1. Press the MENU-button to activate the OSD window.
 2. Press < or > to select the desired function.
 3. Press the MENU-button to select the function that you want to adjust.
 4. Press < or > to change the settings of the current function.
 5. To exit and save, select the exit function. If you want to adjust any other function, repeat steps 2-4.
- P/X Series OSD behave
When user press "MENU" button on front bezel

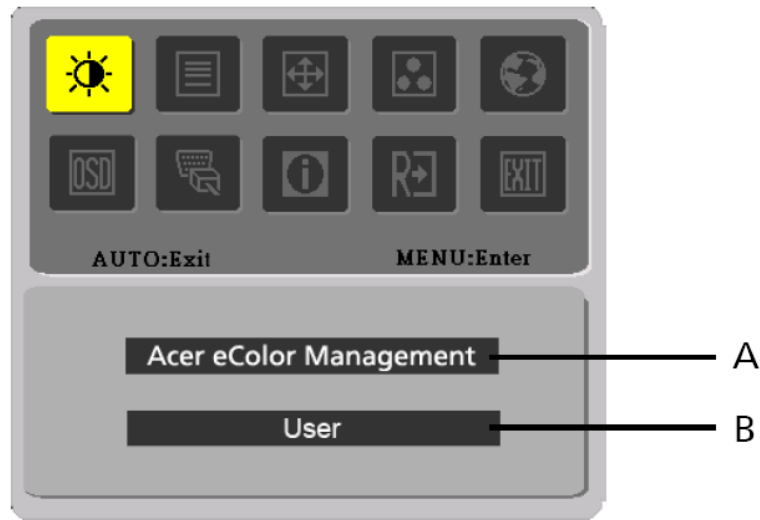

- A. Acer eColor Management
If selected to "Acer eColor Management" item, will appear the Acer eColor" OSD
- B. USER
If selected to "USER" item, will appear the Standard OSD

















I. Only Analog Input Model











II. Only Dual Input Model

Adjusting the picture

| Main Menu icon | Sub Menu icon | Sub Menu item | Description |
|---|---|---------------|---|
|  |  | Contrast | Adjust the contrast between the foreground and background of the screen image |
| |  | Brightness | Adjust the background brightness of the screen image |
| |  | ACM | ACM (Adaptive Contrast Management) ACM ON/OFF Switch, default "OFF" |
|  |  | Focus | Adjust picture Focus (available in analog mode only) |
| |  | Clock | Adjust picture Clock (available in analog mode only) |

| Main Menu Icon | Sub Menu Icon | Sub Menu Item | Description |
|---|---|---------------|---|
|  |  | H. Position | Adjust the horizontal position. (available in Analog mode only) |
| |  | V. Position | Adjust the vertical position. (available in Analog mode only) |
|  | N/A | Warm | Set the color temperature to warm white. |
| | N/A | Cool | Set the color temperature to cool white. |
| |  | User /Red | Adjusts Red/Green/Blue intensity. |
| |  | User /Green | |
| |  | User /Blue | |

| | | | |
|---|-----|------------|---------------------------|
|  | N/A | English | Multi-language selection. |
| | N/A | 繁體中文 | |
| | N/A | Deutsch | |
| | N/A | Francais | |
| | N/A | Espanol | |
| | N/A | Italiano | |
| | N/A | 简体中文 | |
| | N/A | 日本語 | |
| | N/A | Suomi | EMEA version OSD only |
| | N/A | Nederlands | |
| | N/A | Рысскнн | |

| Main Menu Icon | Sub Menu Icon | Sub Menu Item | Description |
|---|---|---------------------------------|--|
|  |  | H. Position | Adjust the horizontal position of the OSD. |
| |  | V. Position | Adjust the vertical position of the OSD. |
| |  | OSD Timeout | Adjust the OSD timeout. |
|  | N/A | Analog | Select input signal from analog (D-Sub) |
| | N/A | Digital (only Dual-Input Model) | Select input signal from digital(DVI) (only Dual-Input Model) |
| | N/A | DDC/CI | Turn ON/OFF DDC/CI support |
|  | N/A | Information | Show the resolution, HV frequency and input port of current input timing. |
|  | N/A | Reset | Clear each old status of Auto-configuration and set the color temperature to Cool. |
|  | N/A | Exit | Save user adjustment and OSD disappear. |

Logo

When the monitor is power on, the LOGO will be showed in the center, and disappear slowly.



How To Optimize The DOS-Mode

Plug And Play

Plug & Play DDC2B Feature

This monitor is equipped with VESA DDC2B capabilities according to the VESA DDC STANDARD. It allows the monitor to inform the host system of its identity and, depending on the level of DDC used, communicate additional information about its display capabilities.

The DDC2B is a bi-directional data channel based on the I²C protocol. The host can request EDID information over the DDC2B channel.

This monitor will appear to be non-functional if there is no video input signal. In order for this monitor to operate properly, there must be a video input signal.

This monitor meets the Green monitor standards as set by the Video Electronics Standards Association (VESA) and/or the United States Environmental Protection Agency (EPA) and The Swedish Confederation Employees (NUTEK). This feature is designed to conserve electrical energy by reducing power consumption when there is no video-input signal present. When there is no video input signals this monitor, following a time-out period, will automatically switch to an OFF mode. This reduces the monitor's internal power supply consumption. After the video input signal is restored, full power is restored and the display is automatically redrawn. The appearance is similar to a "Screen Saver" feature except the display is completely off. Pressing a key on the keyboard, or clicking the mouse restores the display.

Using The Right Power Cord

The accessory power cord for the Northern American region is the wallet plug with NEMA 5-15 style and is UL listed and CSA labeled. The voltage rating for the power cord shall be 125 volts AC.

Supplied with units intended for connection to power outlet of personal computer: Please use a cord set consisting of a minimum No. 18 AWG, type SJT or SVT three conductors flexible cord. One end terminates with a grounding type attachment plug, rated 10A, 250V, and CEE-22 male configuration. The other end terminates with a molded-on type connector body, rated 10A, 250V, having standard CEE-22 female configuration.

Please note that power supply cord needs to use VDE 0602, 0625, 0821 approval power cord in European countries.

This chapter contains step-by-step procedures on how to disassemble the monitor for maintenance.

Disassembly Procedure

1. Remove the HINGE ASSEMBLY as the following indicator. (Fig 1)



Fig 1

2. Remove the back cover and bezel. (Fig 2)

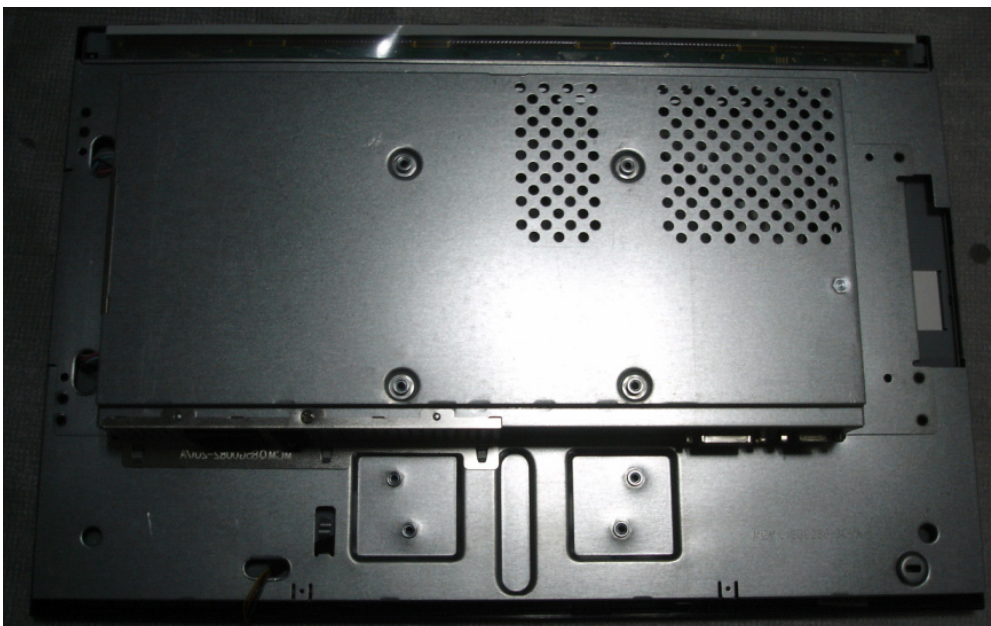

Fig 2

3. Remove the lamp connectors and the screw. (Fig 3-4)

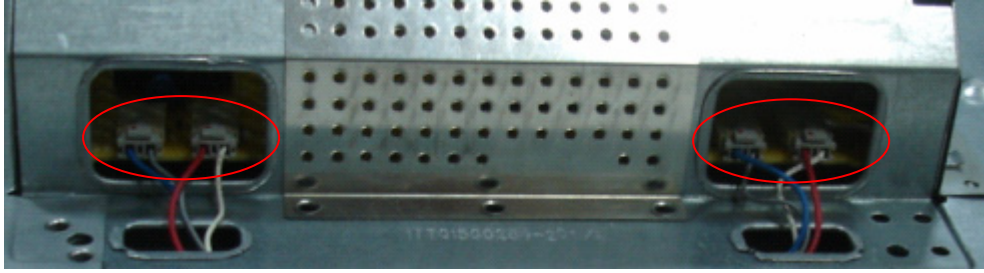

Fig 3



Fig 4

4. Remove the screws to remove the panel. Put attention to the LVDS cable.(Fig 5)

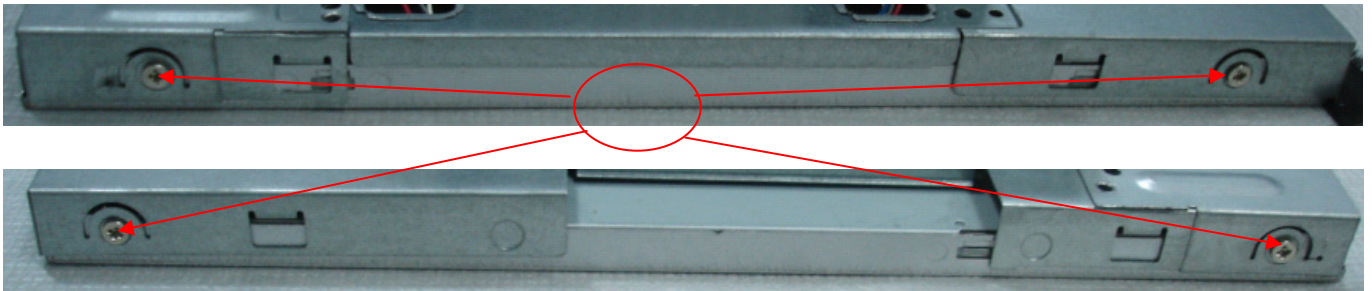

Fig 5

5. Remove the screws to remove the main board and power board.(Fig 6)

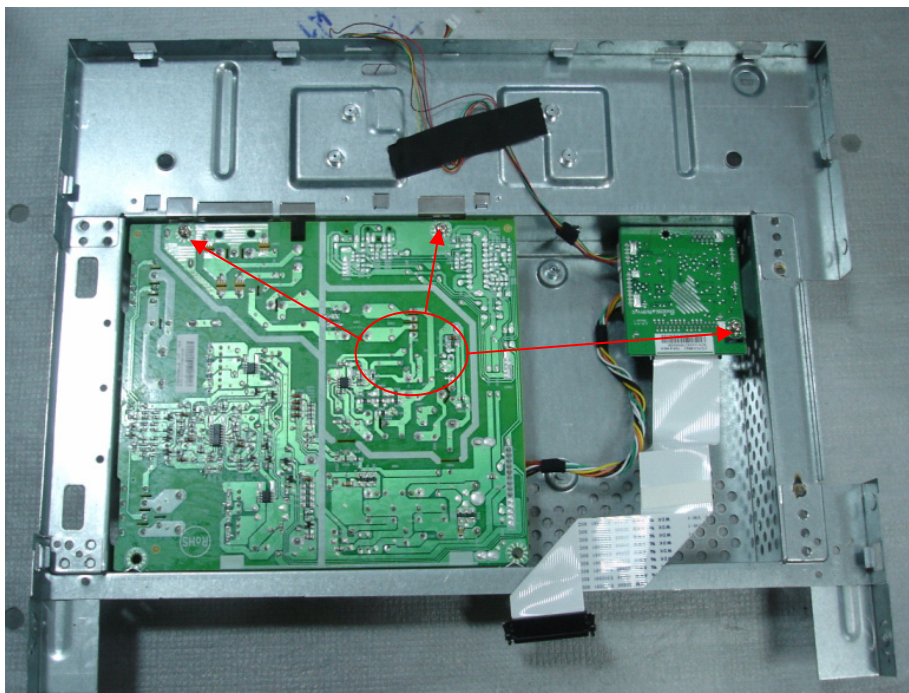
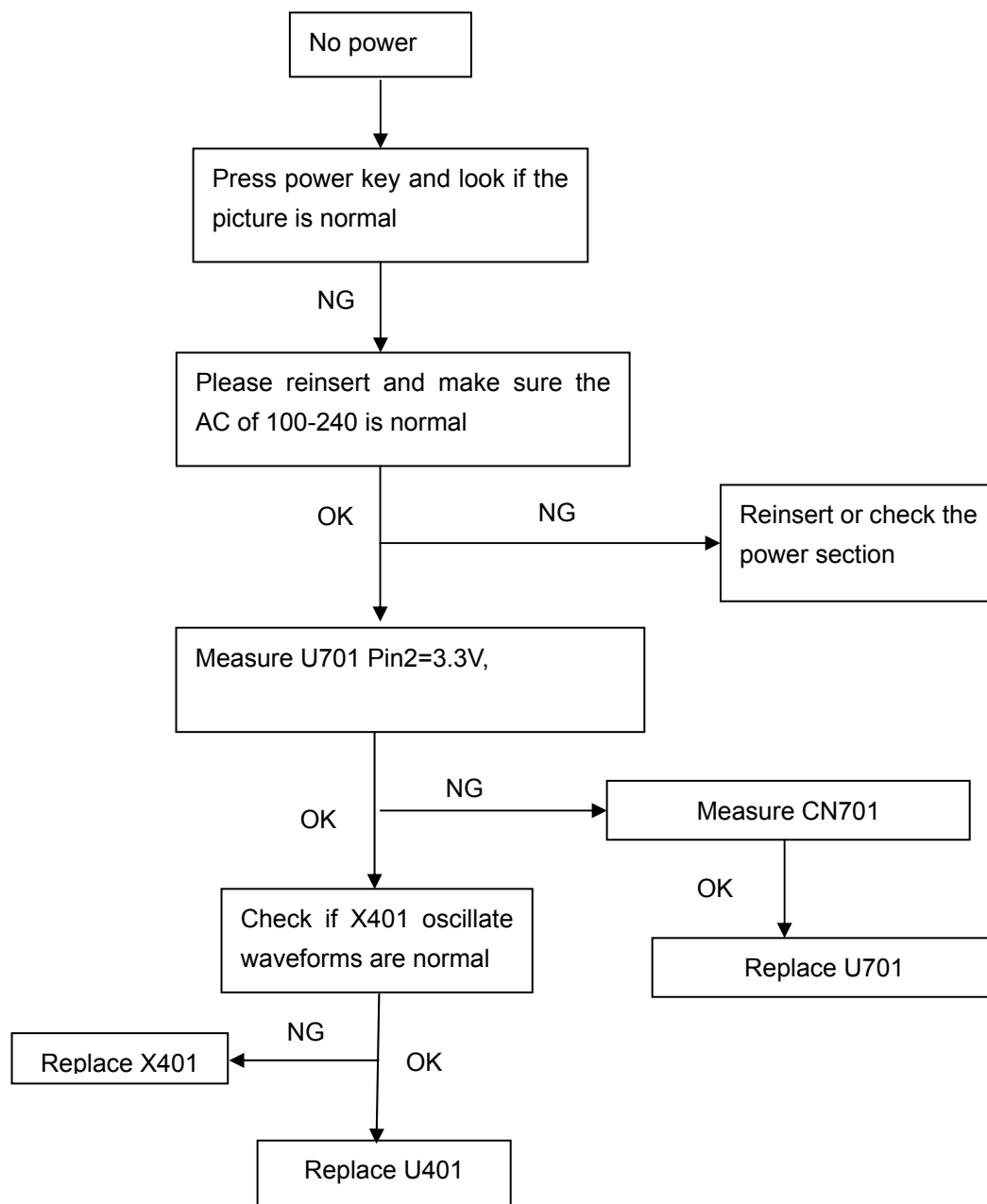

Fig 6

This chapter provides troubleshooting information for the B203W:

1. No Power



2. No Picture (LED is orange)

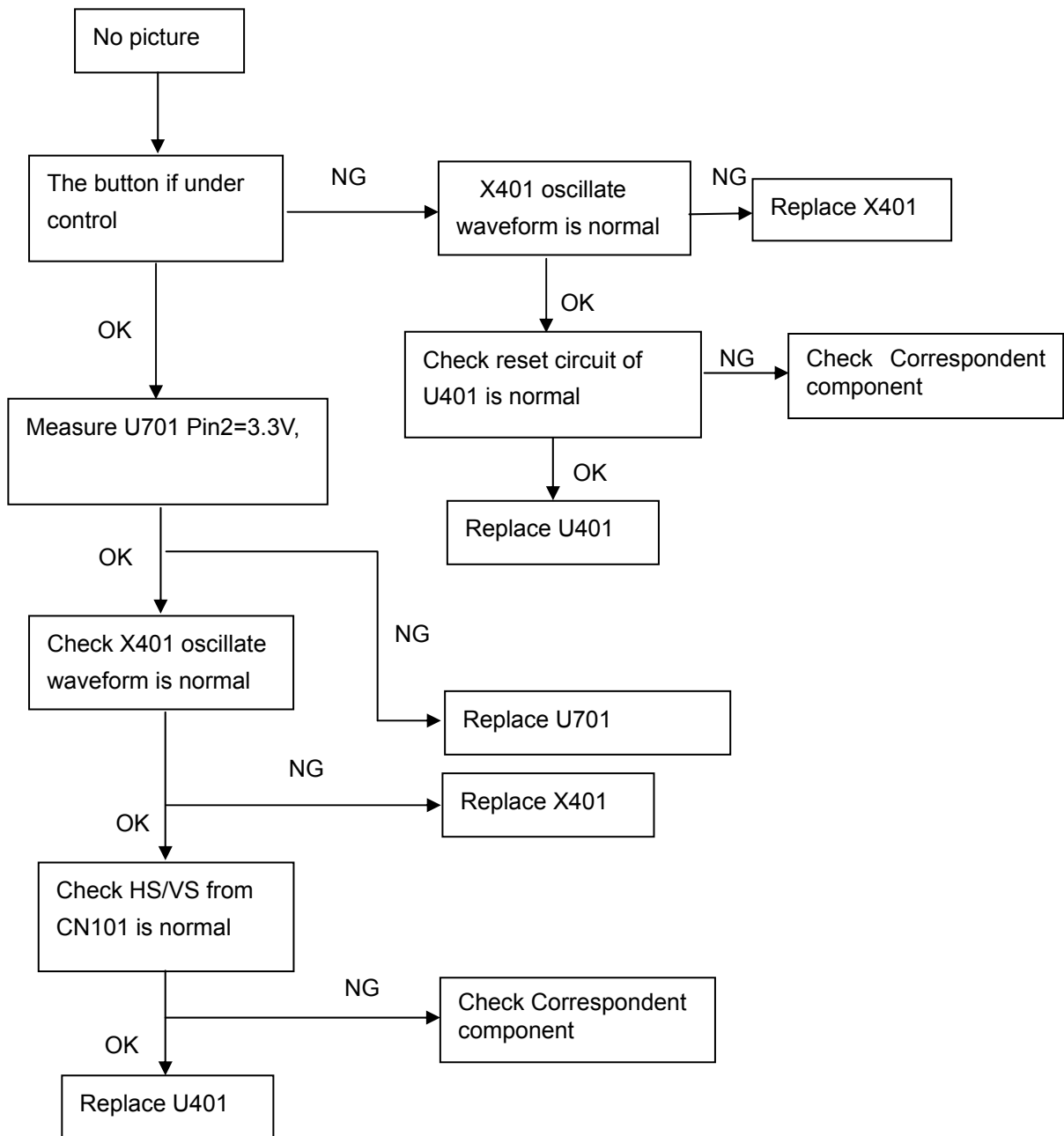

3. Panel Power Circuit

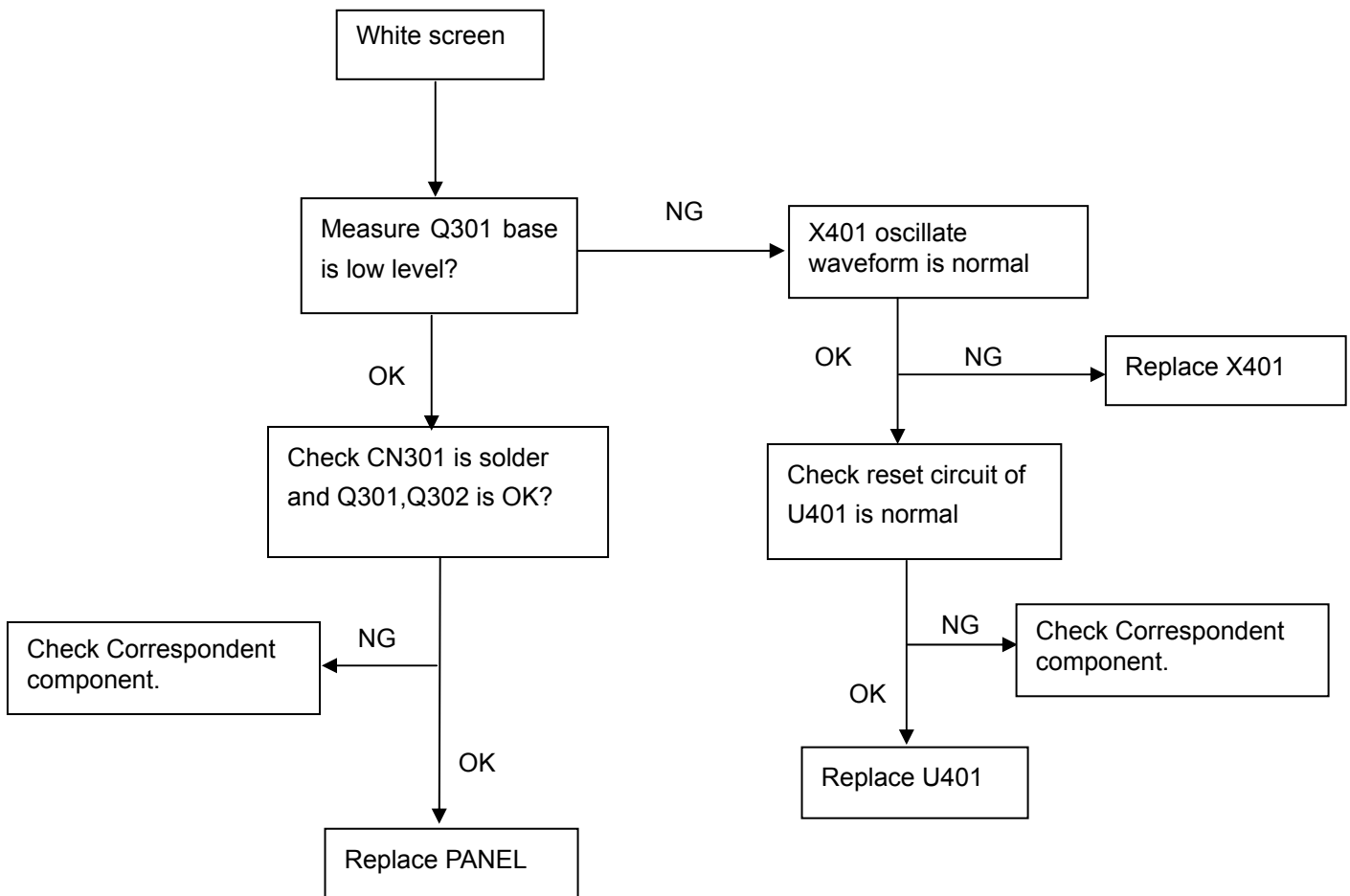

4. Key Board

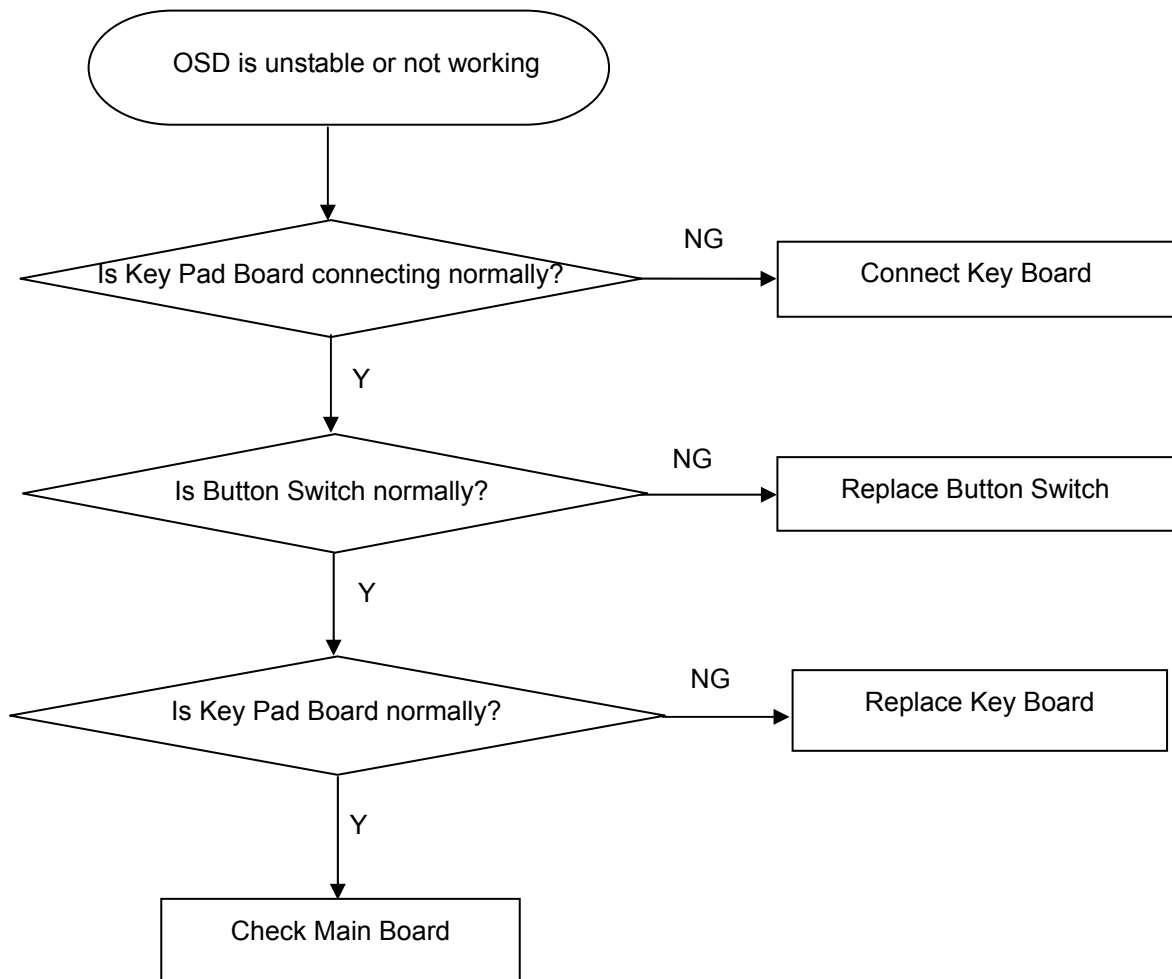

5. Power Board

No power

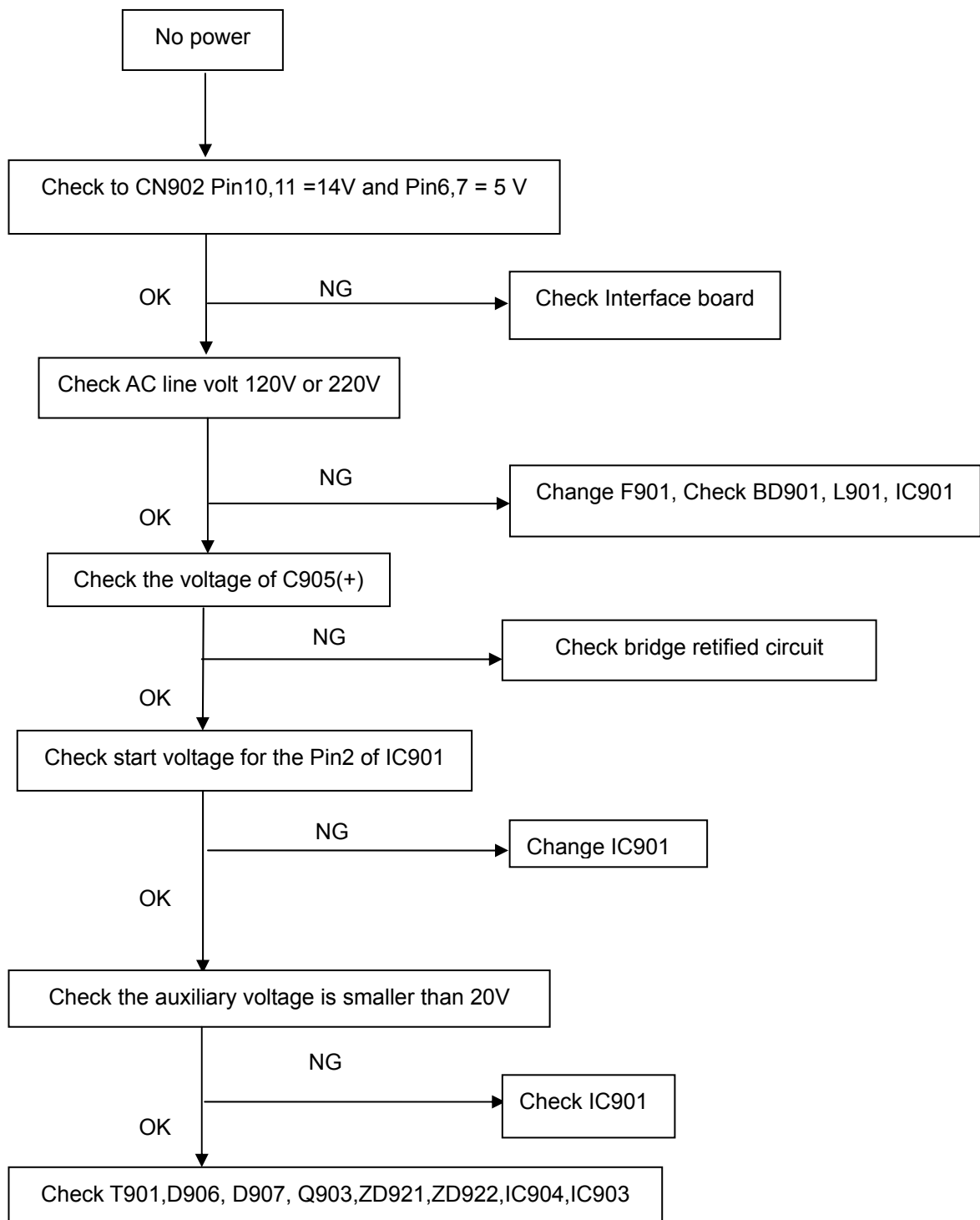

W/LED No Backlight

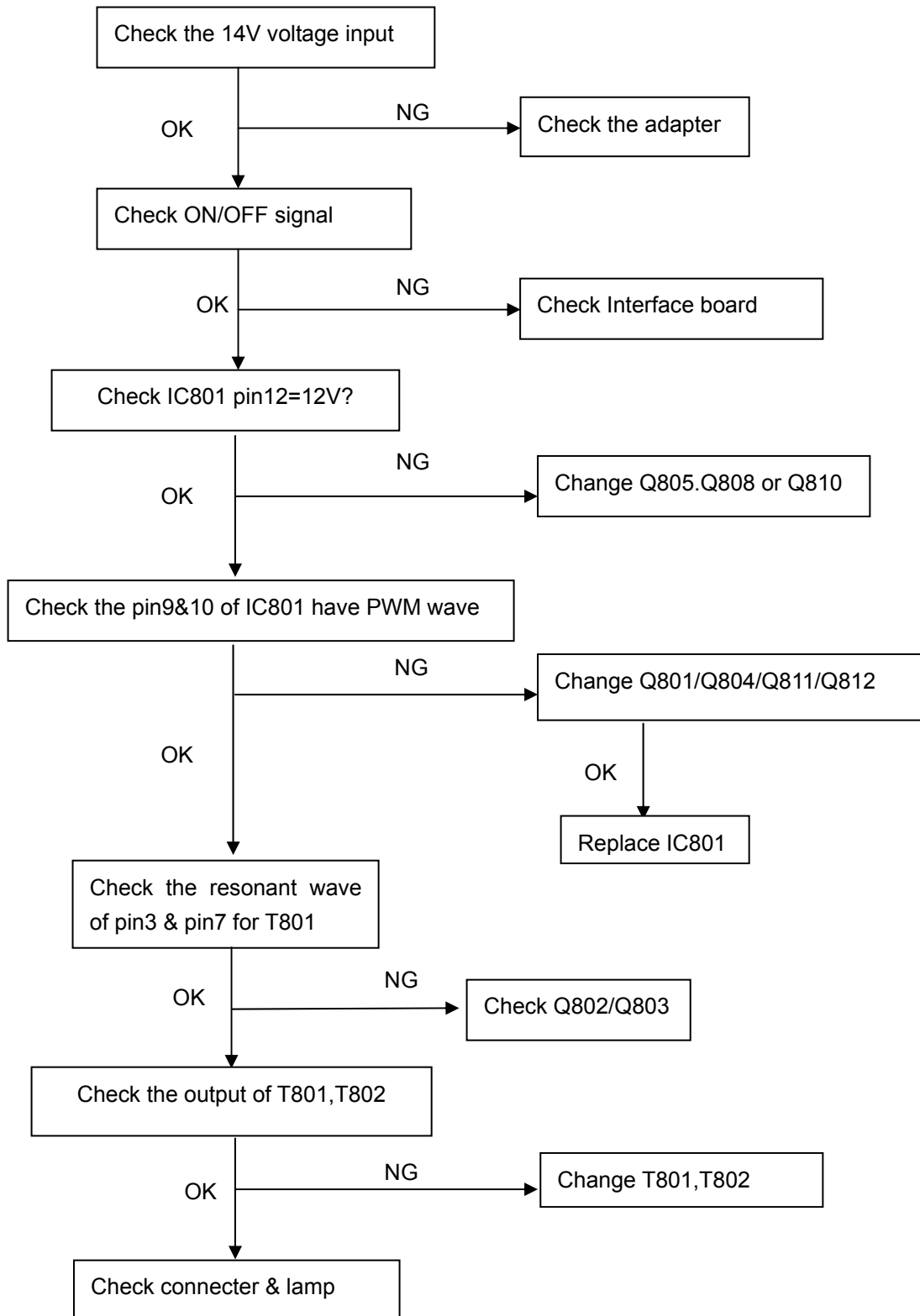

Connector Information

The following figure shows the connector locations on the monitor:

D-SUB connector

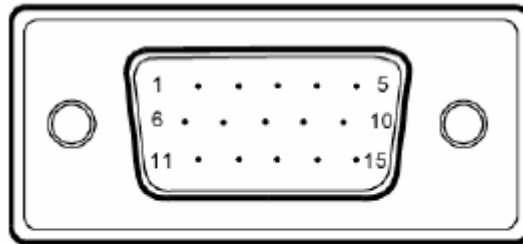

15-Pin Color Display Signal Cable

| PIN NO. | DESCRIPTION | PIN NO. | DESCRIPTION |
|---------|----------------|---------|------------------|
| 1. | Red | 9. | +5V |
| 2. | Green | 10. | Logic Ground |
| 3. | Blue | 11. | Monitor Ground |
| 4. | Monitor Ground | 12. | DDC-Serial Data |
| 5. | DDC-return | 13. | H-Sync |
| 6. | R-Ground | 14. | V-Sync |
| 7. | G-Ground | 15. | DDC-Serial Clock |
| 8. | B-Ground | | |

DVI Connector

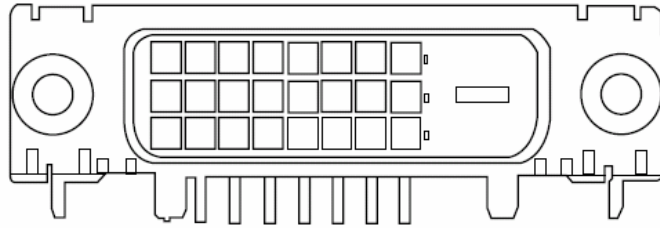

24-pin color display signal cable

| PIN No. | Description | PIN No. | Description |
|---------|----------------------|---------|-----------------------------------|
| 1 | TMDS data 2- | 13 | NC |
| 2 | TMDS data 2+ | 14 | +5 V power |
| 3 | TMDS data 2/4 shield | 15 | GND (return for +5 V hsync.vsync) |
| 4 | NC | 16 | Hot-plug detection |
| 5 | NC | 17 | TMDS data 0- |
| 6 | DDC clock | 18 | TMDS data 0+ |
| 7 | DDC data | 19 | TMDS data 0/5 shield |
| 8 | NC | 20 | NC |
| 9 | TMDS data 1- | 21 | NC |
| 10 | TMDS data 1+ | 22 | TMDS clock shield |
| 11 | TMDS data 1/3 shield | 23 | TMDS clock+ |
| 12 | NC | 24 | DDC TMDS clock- |

This chapter gives you the FRU (Field Replaceable Unit) listing in global configurations of B203W. Refer to this chapter whenever ordering for parts to repair or for RMA (Return Merchandise Authorization).

NOTE: Please note WHEN ORDERING FRU PARTS, that you should check the most up-to-date information available on your regional web or channel (<http://aicsl.acer.com.tw/spl/>). For whatever reasons a part number change is made, it will not be noted in the printed Service Guide. For ACER AUTHORIZED SERVICE PROVIDERS, your Acer office may have a DIFFERENT part number code from those given in the FRU list of this printed Service Guide. You MUST use the local FRU list provided by your regional Acer office to order FRU parts for repair and service of customer machines.



NOTE: To scrap or to return the defective parts, you should follow the local government ordinance or regulations on how to dispose it properly, or follow the rules set by your regional Acer office on how to return it.

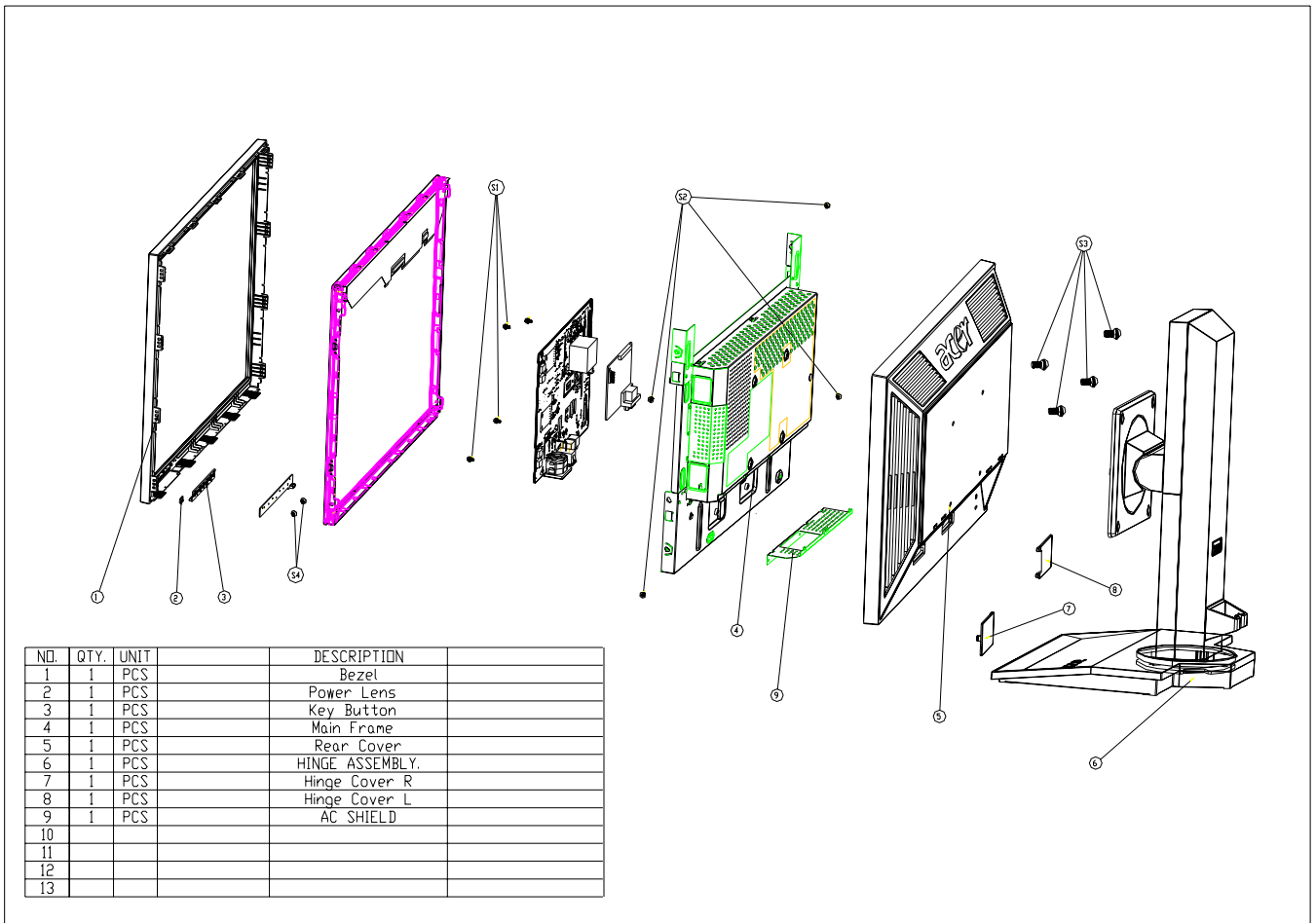

Exploded Diagram (Model: B203W)

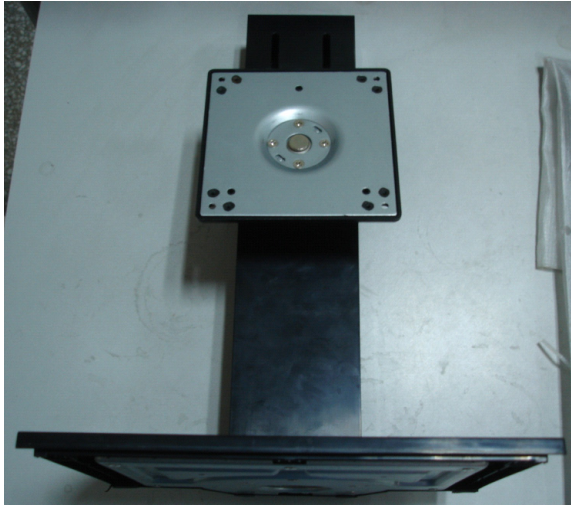
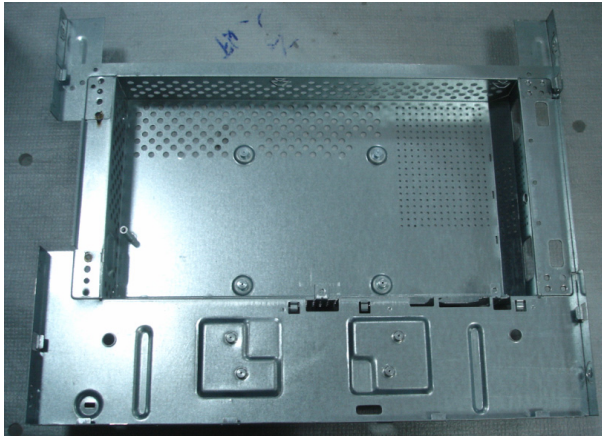

Part List

Above picture show the description of the following component.

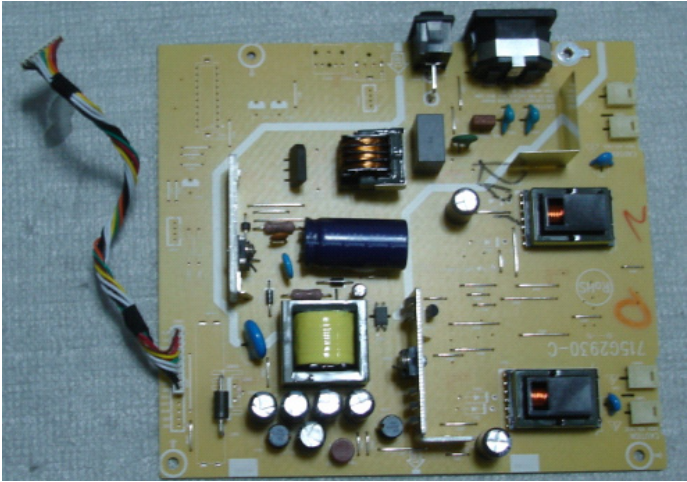
| Item | Picture | Description |
|------|--|----------------|
| 1 |  | HINGE ASSEMBLY |
| 2 |  | Main Frame |
| 3 |  | Panel |

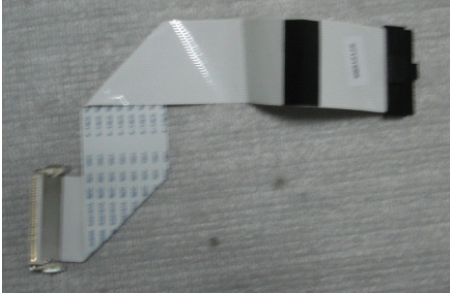
| | | |
|---|---|-------------|
| 4 |  | Power Board |
| 5 |  | Main Board |
| 6 |  | FFC CABLE |

Main Board

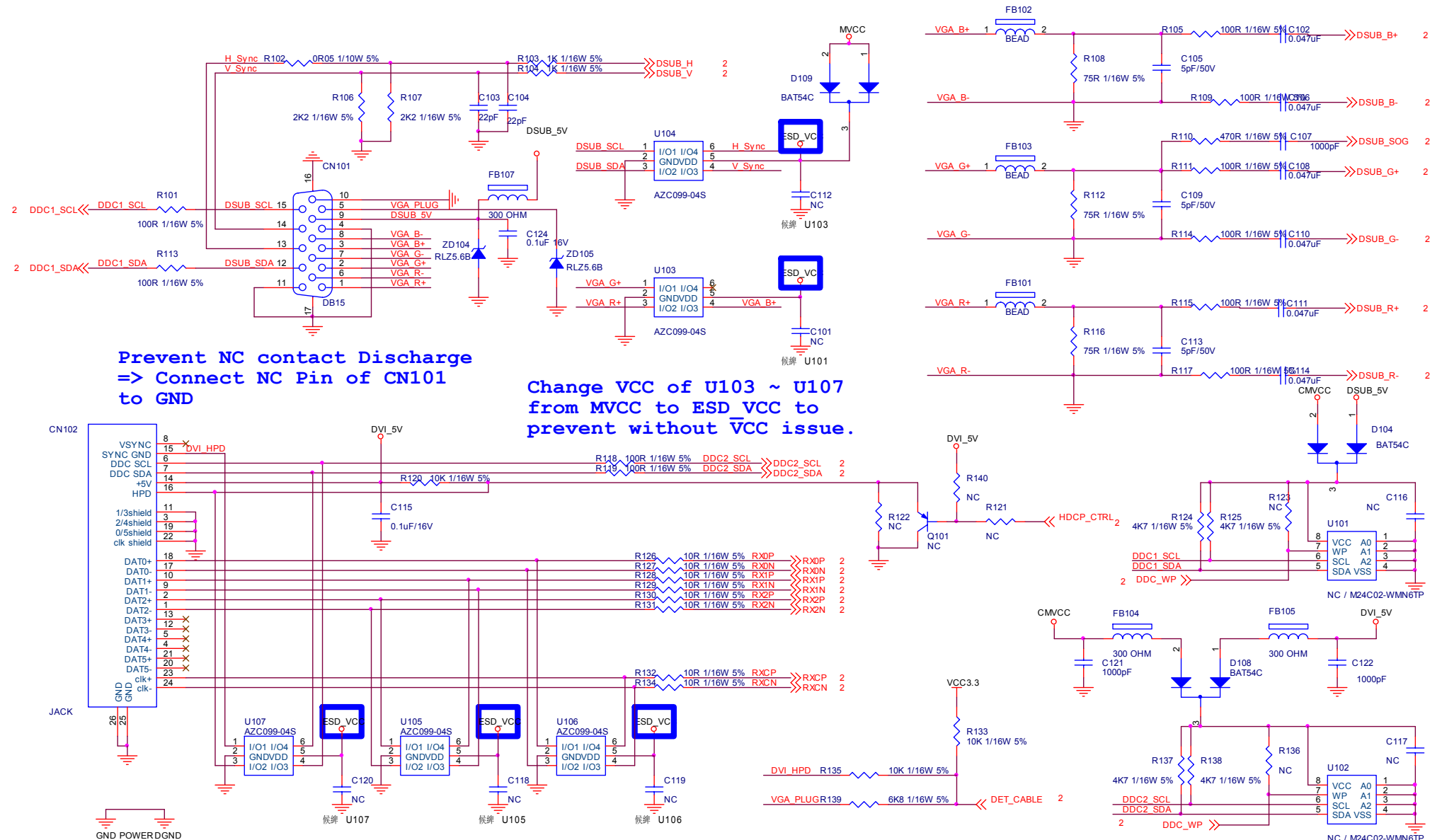

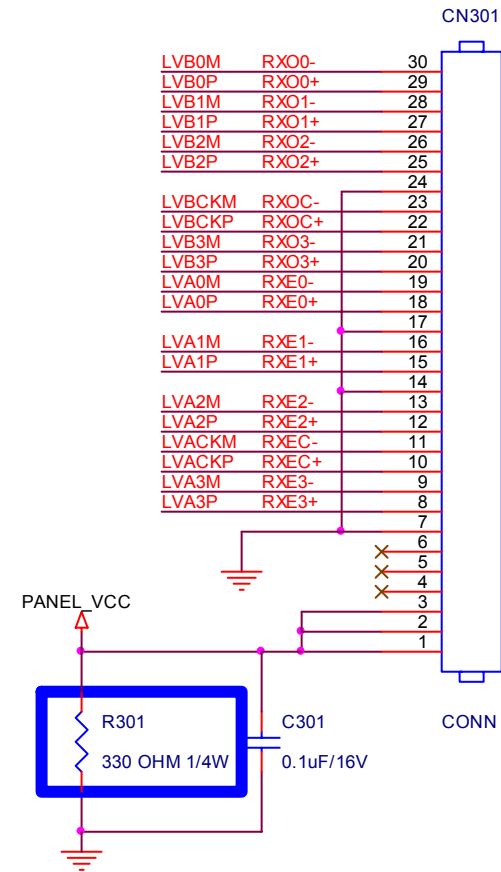
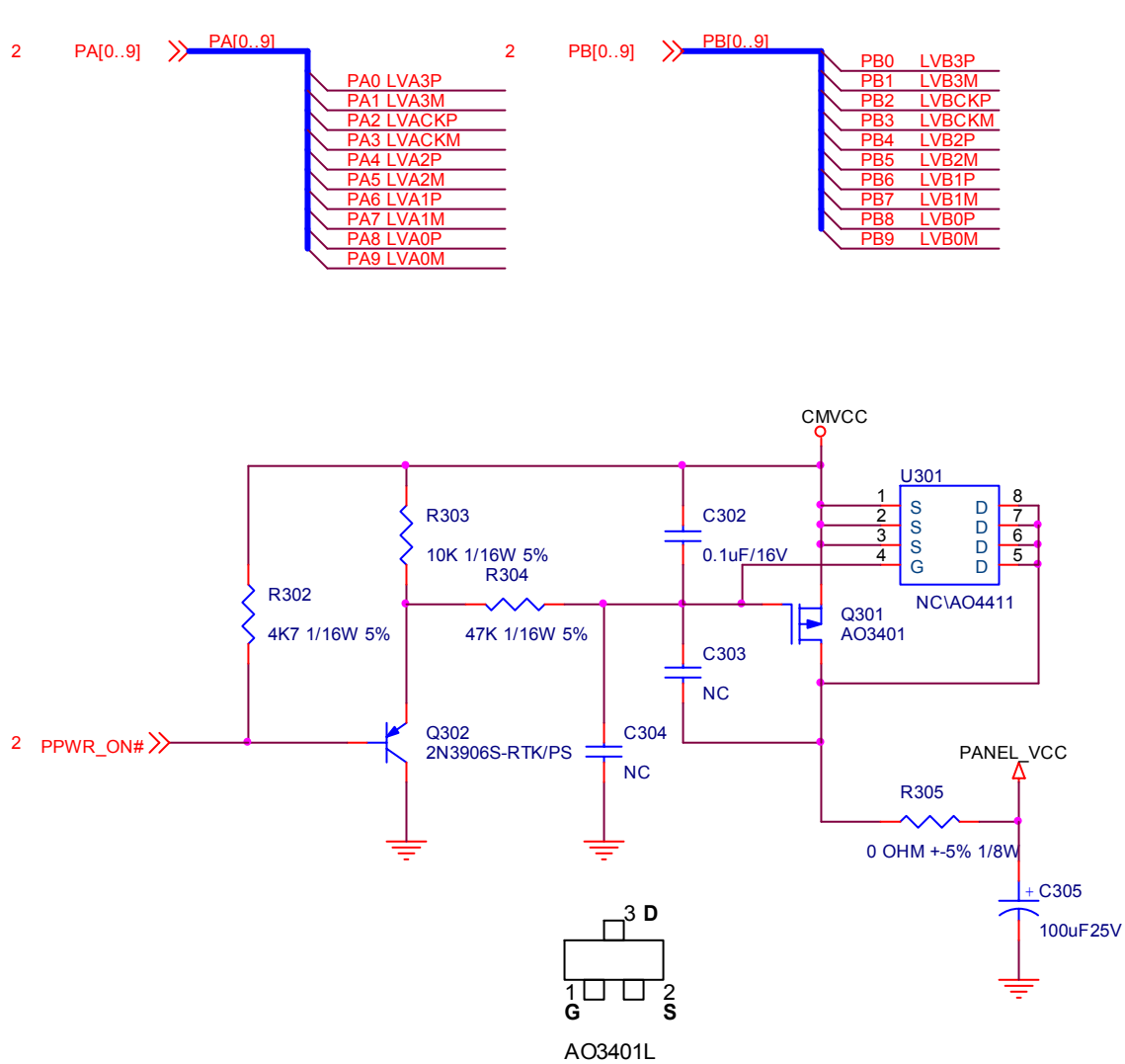

Change the type
of resistor R301
from 0805 to
1206.

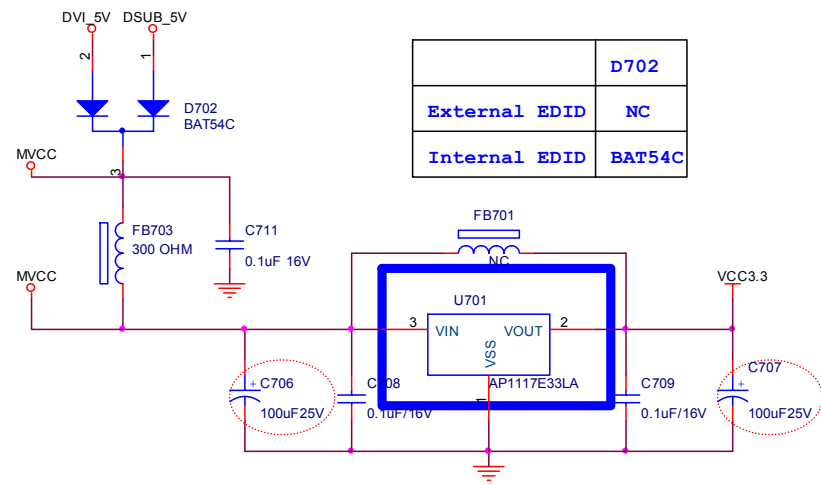
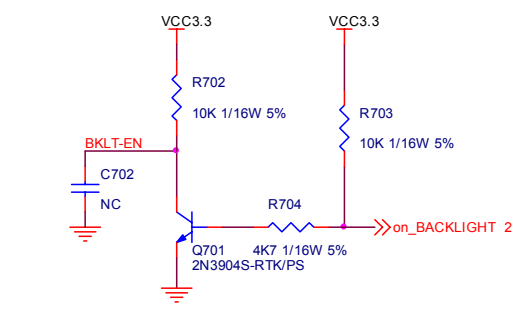
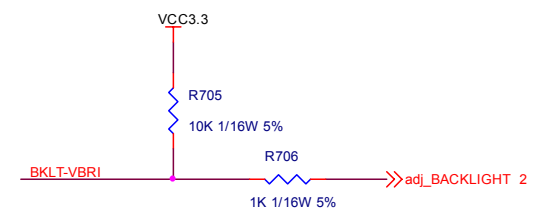
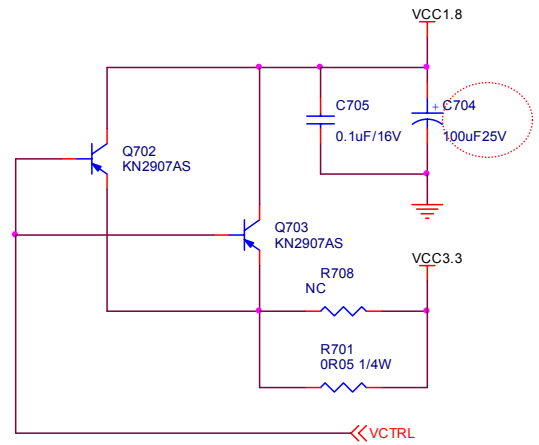
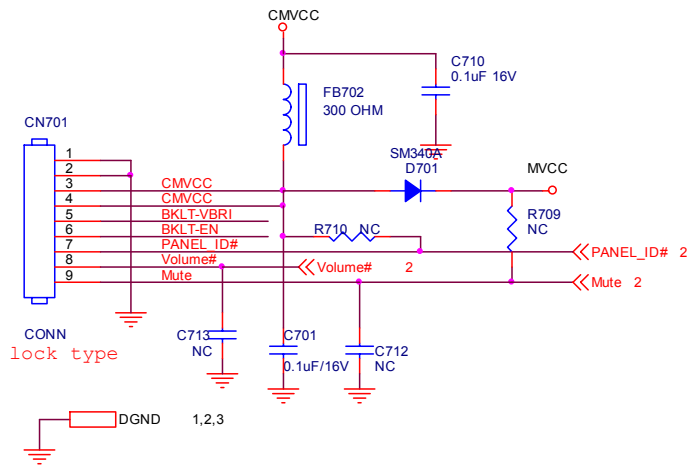

| | |
|---------------|--------|
| | D702 |
| External EDID | NC |
| Internal EDID | BAT54C |

| | R701 | R708 | U701 |
|-------------|-----------|------------|------|
| TSUM5PFHL | 0R05 1/4W | NC | 223 |
| TSUMU58EHL | NC | 3.3 OHM 2W | 223 |
| TSUMO58CWHL | NC | 3.3 OHM 2W | 252 |
| | | | |
| | | | |

Both 223 and 252 foot-print

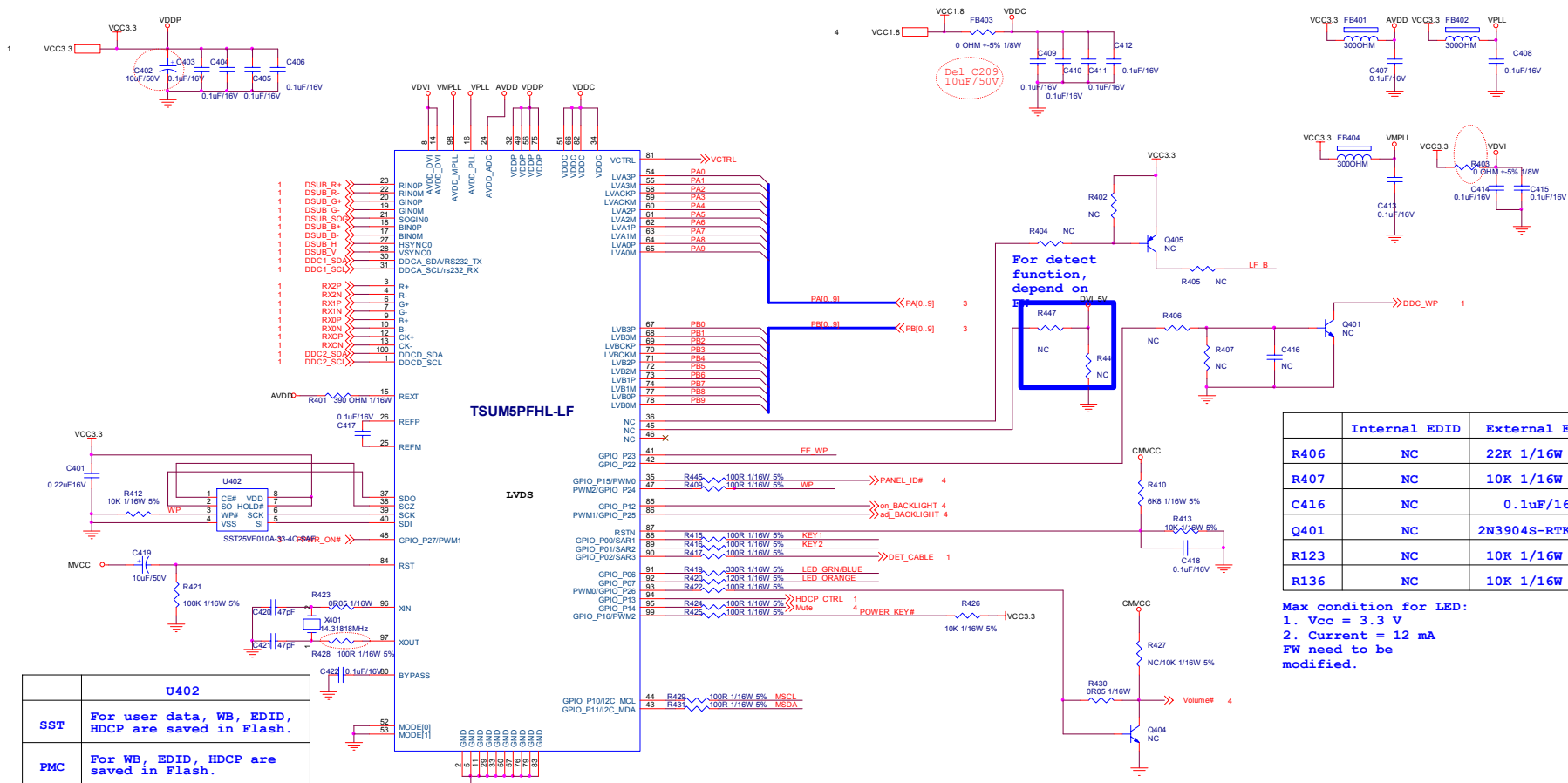

| | Internal EDID | External EDID |
|------|---------------|----------------|
| R406 | NC | 22K 1/16W 5% |
| R407 | NC | 10K 1/16W 5% |
| C416 | NC | 0.1uF/16V |
| Q401 | NC | 2N3904S-RTK/PS |
| R123 | NC | 10K 1/16W 5% |
| R136 | NC | 10K 1/16W 5% |

Max condition for LED:
 1. Vcc = 3.3 V
 2. Current = 12 mA
 FW need to be modified.

| | U402 |
|-----|---|
| SST | For user data, WB, EDID, HDCP are saved in Flash. |
| PMC | For WB, EDID, HDCP are saved in Flash. |

| | U402 |
|------|----------------------|
| 010A | Befor AOC ID2007 OSD |
| 020A | For ID2008 |

X'TAL
 Normal Function : $CL = C_s + ((C_g * C_d) / (C_g + C_d))$
 P.S : Assume $C_s = 4 \text{ pF}$

| | X401 | CL of SPEC | Cs and Cd (C420, C421) |
|----|----------------|------------|------------------------|
| 瑞 | (93G 22-53B-H) | 18 pF | 27 pF |
| 瑞红 | (93G 22-53-J) | 32 pF | 56 pF |

| | CN401 | CN402 | FB405 and C436 |
|-------------|--------------------|----------------|------------------|
| For Normal | NC | WAFER 2.0MM 6P | NC |
| For Philips | NC | WAFER 2.0MM 7P | According to EMI |
| For DELL | FPC CONN. 1.0mm 8P | NC | NC |

| | U403 | R440 | R441 | R442 | C423 |
|-----|---|--------|--------------|--------------|------------|
| SST | For user data, WB, EDID are saved in Flash. | NC | NC | NC | NC |
| PMC | For WB, EDID are saved in Flash. | M24C04 | 10K 1/16W 5% | 10K 1/16W 5% | 0.22uF/16V |

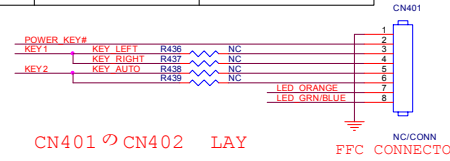
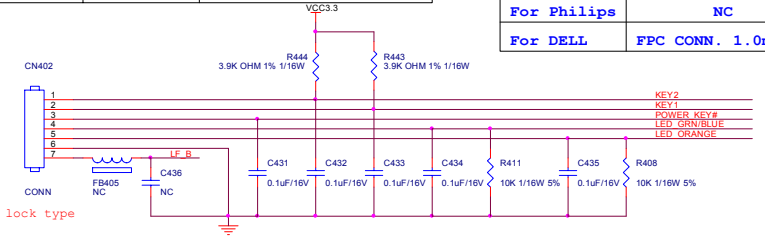

Power board

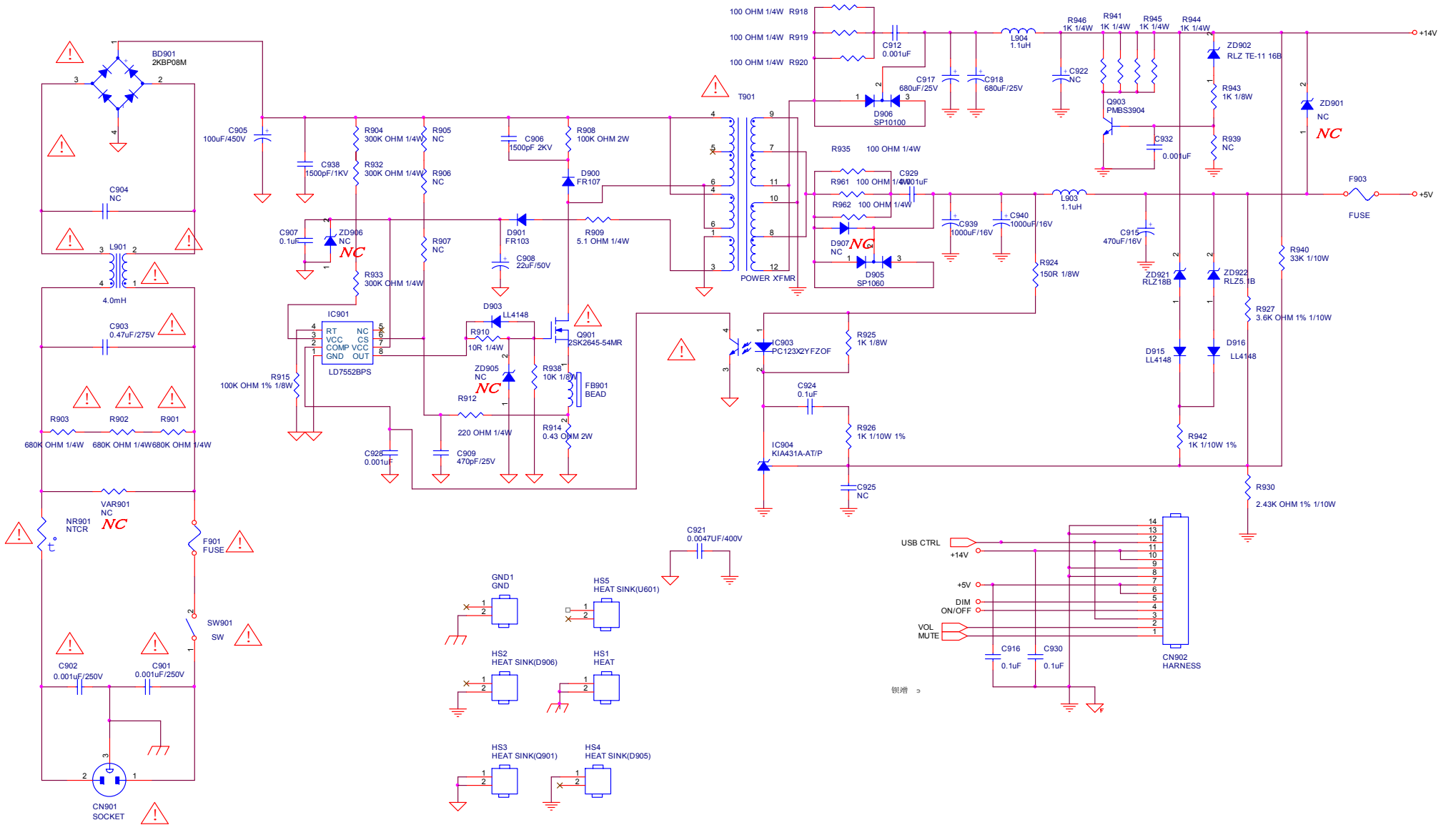

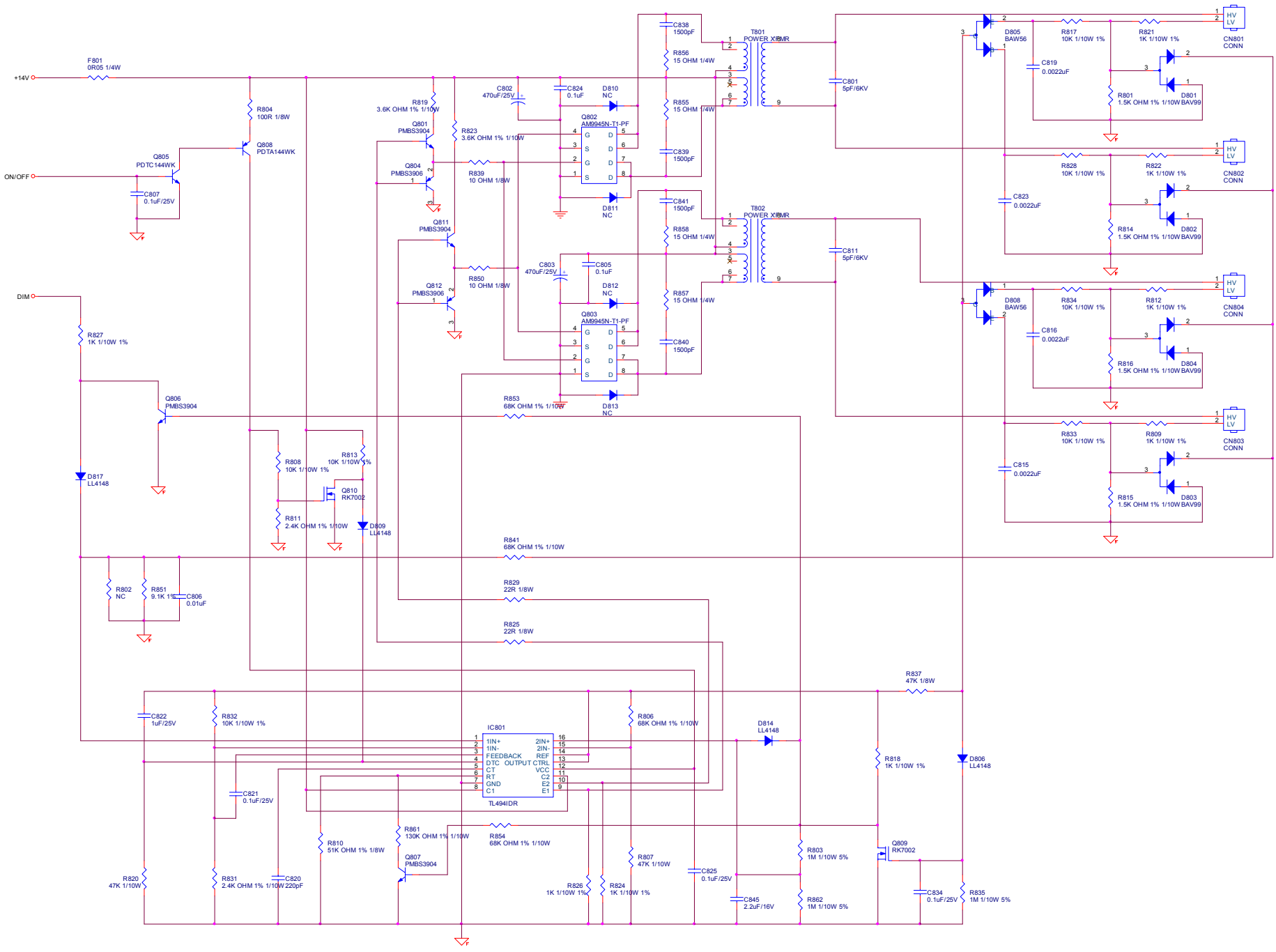

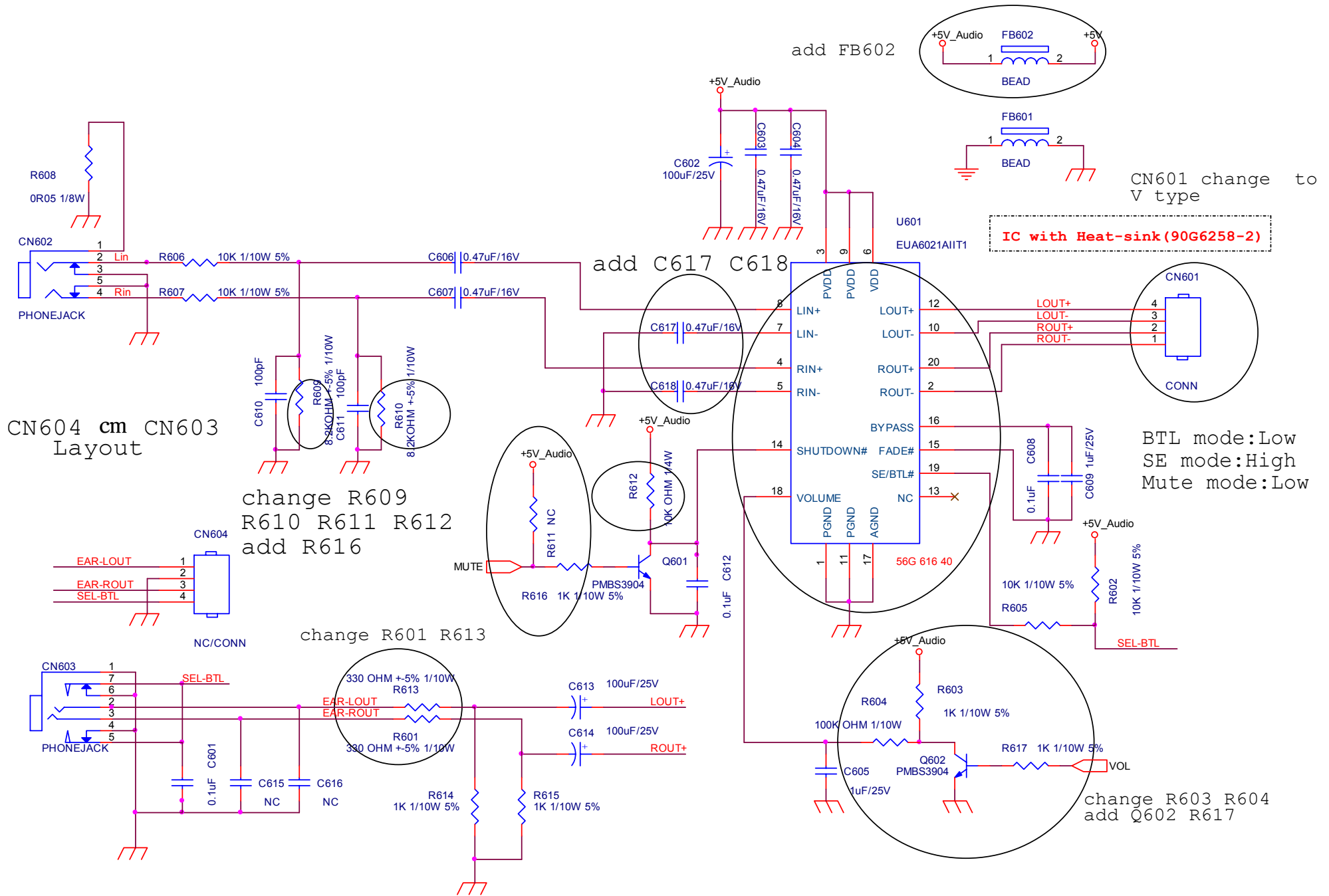

Key board

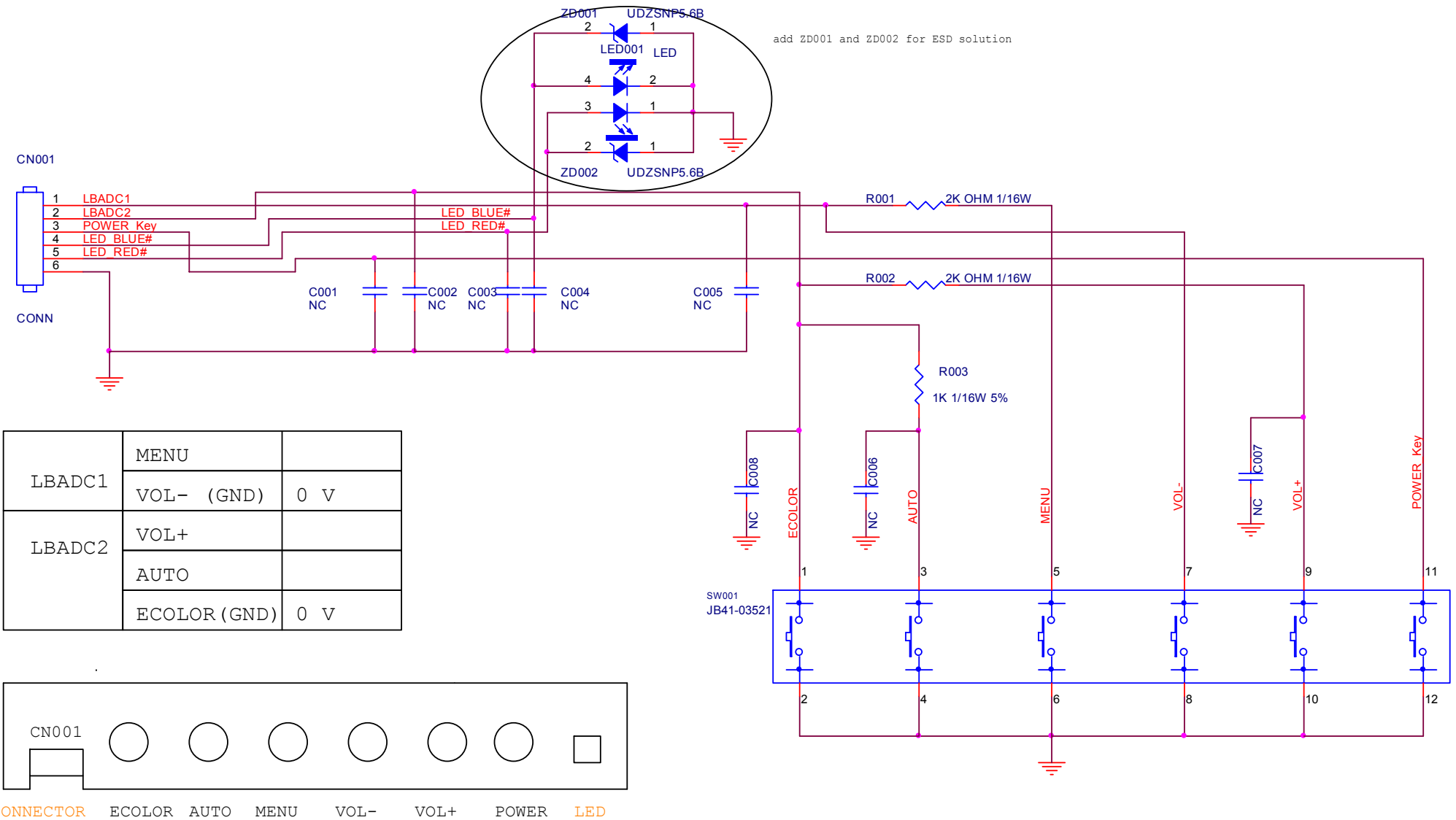

Free Manuals Download Website

<http://myh66.com>

<http://usermanuals.us>

<http://www.somanuals.com>

<http://www.4manuals.cc>

<http://www.manual-lib.com>

<http://www.404manual.com>

<http://www.luxmanual.com>

<http://aubethermostatmanual.com>

Golf course search by state

<http://golfingnear.com>

Email search by domain

<http://emailbydomain.com>

Auto manuals search

<http://auto.somanuals.com>

TV manuals search

<http://tv.somanuals.com>