

Service Manual

LCD Monitor Acer B223W

Table of Contents

- Important Safety Notice01
- 01 Product Specification03
- 02 Flat Panel Specification 18
- 03 Exploded Diagram37
- 04 Troubleshooting39
- 05 Spare Parts List44
- 06 Schematics and Layouts.....45
- 07 Assembly and Disassembly48

Appendix : User’s manual

Copyright

Copyright 2006 InnoLux Tech. Corp. Ltd

All Rights Reserved

This manual may not, in whole or in part, be copied, Photocopied, reproduced, translated, or converted to any electronic or machine readable form without prior written permission of InnoLux Tech. Corp. Ltd.

Acer B223W Service Manual

Important Safety Notice

1. Safety precautions

This monitor is manufactured and tested on a ground principle that a user's safety comes first. However, improper use or installation may cause damage to the monitor as well as to the user.

Warning:

- This monitor should be operated only at the correct power sources indicated on the label on the rear of the monitor. If you're unsure of the power supply in your residence, consult your local dealer or Power Company.
- Do not try to repair the monitor by yourself, as it contains no user-serviceable parts. This monitor should only be repaired by a qualified technician.
- Do not remove the monitor cabinet. There are high-voltage parts inside that may cause electric shock to human bodies.
- Stop using the monitor if the cabinet is damaged. Have it checked by a service technician.
- Put your monitor only in a lean, cool, dry environment. If it gets wet, unplug the power cable immediately and consult your closed dealer.
- Always unplug the monitor before cleaning it. Clean the cabinet with a clean, dry cloth. Apply non-ammonia based cleaner onto the cloth, not directly onto the glass screen.
- Do not place heavy objects on the monitor or power cord.

2. Product safety notice

Many electrical and mechanical parts in this chassis have special safety visual inspections and the protection afforded by them cannot necessarily be obtained by using replacement components rated for higher voltage, wattage, etc. Before replacing any of these components read the parts list in this manual carefully. The use of substitute replacement parts, which do not have the same safety characteristics as specified in the parts list, may create shock, fire, or other hazards.

3. Service notes

- When replacing parts or circuit boards, clamp the lead wires around terminals before soldering.
- Keep wires away from high voltage, high temperature components and sharp edges.
- Keep wires in their original position so as to reduce interference.
- Adjustment of this product please refers to the user's manual.

01 Product Specification

1. General:

BV223W series LCD monitor is designed with a wide screen 22.0" WSXGA+ TFT LCD panel, LVDS interface, Analog RGB signal input.

It featured with embedded universal AC power supply. This monitor can support maximum resolution up to 1680 x 1050@60Hz.

Details in this document DVI referred to is an option function depending on client's requirement. In our factory, products should be distinguished by module names.

1.1 Main Features

Maximum resolution	: 1680 x 1050 @ 60Hz	
Back light system	: 4 CCFL (top & bottom edge side)	
Pixel pitch	: 0.282 (H) x 0.282 (V)	
Display area	: 473.76(H)x296.1(V) 22.0 inch diagonal	
Brightness	: ≥ 250 cd/m ²	
Contrast ratio	: 1000:1 (typ.)	(1)
Response time (Tr+Tf)	: 5ms (typ.)	(2)
Viewing angle	: 160°(H)/ 160°(V), typ	(3)
Input interface	: Analog (D-sub 15 pin)	
Digital Option(DVI-D 24 pin)		
Power management	: Compatible with VESA DPMS	
Plug & Play	: VESA DDCCI	
OSD language	: English, French, Spanish, Italian, Deutsch, Simplified Chinese, Traditional Chinese, Japanese (Dutch, Finnish, Russian depend on sale region)	
Universal AC power supply		

Note (1)(2)(3): This item spec depend on the LCD panel.

1.2 Accessories

AC Power Cord	: 1.8 m. (Black. Cord type depend on sale region)
VGA cable	: 1.8 m. (15 pin D-SUB, black cable with blue male connector)
User manual	: English (640Mb CD)
Warranty card	
DVI cable (option)	: 1.8 m. (18+1 pin, black cable with white connector)

2. Operation Specifications

The unit should suffer no visible cosmetic damage and should operate with no degradation in display quality during exposure to the operating conditions and after exposure to the non-operating conditions, in any sequence.

2.1.1 Operating:

Temperature range	: 0°C to 40°C
Relative humidity	: 20% to 90%

2.1.2 Storage ^{note 1}:

Temperature range	: -20°C to 60°C
Humidity range	: 10% to 90%

2.1.3 Altitude ^{note 2}

Operating	10000 ft (Ta=50, t=24h)
Storage	40000 ft (Ta=30, t=24h)

Note 1: Temperature and relative humidity range must be in the area shown as the following figure due to panel limited

Note 2: Altitude spec must not over panel spec.

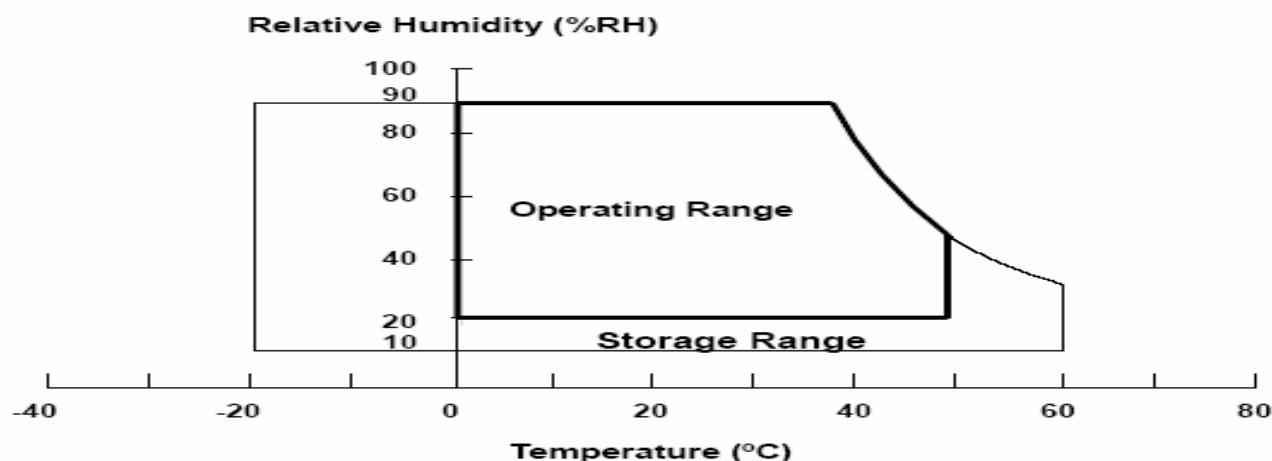

Figure 1 Absolute Ratings of Environment

2.1 Safety, EMC, Ergonomics and Compatibility Requirements

Safety & EMC	cUL, UL, CE, CB, CCC, TUV/GS, TUV/EGO, TUV/ISO-13406-2, C-Tick (N214), VCCI, FCC, CE, CCC, BSMI, C-Tick
Ergonomics	TCO99, TCO03
Compatibility	Windows 98/Me/2000, Windows XP, Window Vista
Power Management	Energy Star V4

2.2 Electrostatic Discharge Requirements

The subject unit must withstand $\pm 8\text{KV}$ for contact discharge and $\pm 15\text{KV}$ for air discharge of Electrostatic Discharge and meet the standard of IEC61000-4-2(EN55024). (without discharge on VGA/DVI/HDMI pin)

2.3 Reliability

The MTBF of this product shall be greater than 40,000 hours excluding the LCD panel. The LCD panel life which is defined as the time period for the maximum luminance to reduce to 50% of the initial value is 40,000 hours minimum at the condition of displaying an all WHITE field at mid Brightness and Contrast settings.

3. Electrical and Optical Characteristics and Performance

3.1 Backlight Power Supply

3.1.1 AC Input Voltage Range

It is a universal type and the input voltage range is from 100 ~ 240Vrms

3.1.2 AC Input Current

1.2A (max) at 100VAC input

0.6A (max) at 240VAC input

3.1.3 AC Frequency Range

The frequency range is from 50Hz to 60Hz

3.1.4 Inrush Current

a. 40A max at cold-start, 25°C, DC output full-loading and 100Vac input

b. 60A max at cold-start, 25°C, DC output full-loading and 240Vac input

Notes: 1. Before each test, the buck capacitor need to be discharged.

2. Before each test, it must be 10 minutes at least after the latest test.

3.1.5 Regulator Efficiency $\geq 75\%$

(DC output full loading and nominal AC input voltage range)

3.1.6 Ripple and Noise

Total composite ripple and noise less than 320mV for +16V output, and less than 150mV for +5V output, and 50mV for +3.3V output tested by DC loading side parallel with a 47uF/EC and 0.1uF/Ceramic. Capacitors and measured band-width with DC-20MHz

3.1.7 DC Output Voltage and Current

DC Output	Voltage	Current	
		Typ.	Max.
VCC16V	15.2V-18.5V	1.8A	2.2 A
VCC5V	4.75~5.25V	1.5A	1.8A

Note: For the normal loading test ,the output loading use typical current.

3.1.8 Protection

- SCP: For short circuited protection and with auto-recovery function.(for 5V output it must be shorted before F802)
- OPP: Over-power protection, Range: 60W (min) on nominal AC input.
- BOP: Brown Out protection

Condition: Pattern: Dot pattern,

Timing: 1680x1050 60Hz,

Brightness: Max.

Contrast: Max

Spec: system shutdown voltage must be > 50V

system restart voltage must be <85V

3.1.9 Power consumption

Max. 55W.

Follow Energy Star V4 condition 49W

3.1.10 Power management

BV223W supports Energy Star V4 and VESA DPMS

Status	H-sync	V-sync	Video	Power	LED
On Mode/Active Power	on	on	active	≤ 55W	Blue
Sleep Mode/Low Power	off	on	blanked	< 2W	Orange
	on	off	blanked	< 2W	Orange
	off	off	blanked	< 2W	Orange
Off Mode/Standby Power	--	--	--	< 1W	Off

3.2 Backlight

Item	Symbol	Min.	Typ.	Max.	Unit	Remark
Input Voltage	Vin	15.2	16.0	18.5	V	
Enable (On/Off)	Von	2.0	3.3	5.5	V	
	Voff	-0.3	---	0.8	V	

Kick off Voltage:

Item	Symbol	Min.	Typ.	Max.	Unit	Remark
Kick off Voltage	Vs	1700	---	---	Vrms	

On Load Function:

Item	Symbol	Min.	Typ.	Max.	Unit	Remark
Input Current	I_{in}	---	1.8	2.2	A	
Frequency	F	40.0	45.0	80	kHz	@Max-Load
Output Current for One Lamp	I_L	3.0	7.0	8.0	mA _{rms}	PWM dimming control mode: $2mA \leq I_L \leq 8mA$
Operating Voltage	V_o	---	750	---	V _{rms}	
Brightness PWM duty		35%	---	100%		
Kick Off Voltage Hold Up Time	T	1.0	1.5	---	S	@Vin=16.0V Brightness=3.3V
Efficiency	η	75%	---	---		@Vin=16.0V Brightness=3.3V

3.3 Brightness output

The test to verify specifications in this section shall be performed under the following standard conditions unless otherwise noted.

Temperature	: $25 \pm 5^\circ\text{C}$
Test pattern	: white
Video Resolution	: 1680 x 1050
Video input level	: $700 \text{ mV} \pm 2\%$
Warm-up time	: 30 minutes

Set brightness control and also contrast control at maximum, to measure the screen center, the light output

shall $\geq 250 \text{ cd/m}^2$ (as panel spec)

3.4 White balance

The test standard conditions refer to Sec 3.3.(Brightness control is at 100 contrast control is at 50)

Mode		Chromaticity Coordinate	
		x	y
Cool	9300K	0.283 ± 0.030	0.297 ± 0.030
Warm	6500K	0.313 ± 0.030	0.329 ± 0.030
User		Panel While x	Panel While y

3.5 Brightness uniformity

The test standard conditions refer to Sec 3.4.

$$\frac{\text{Min. luminance of nine points (backlight)}}{\text{Max. luminance of nine points (backlight)}} = 75\%$$

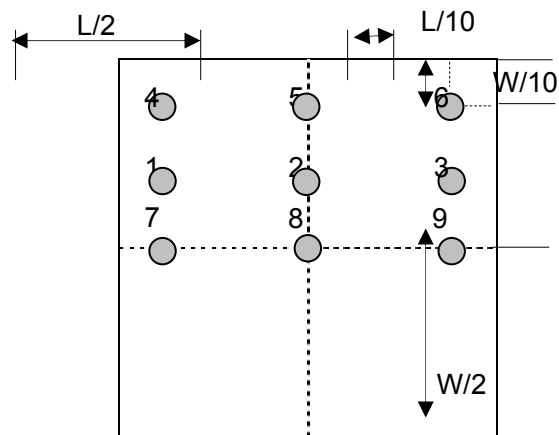

4. Input / Output Signal Specifications

4.1 Video signals

Analog RGB signal: 0.7Vp-p (Input impedance = 75 Ohm)

Sync: TTL level (Input impedance 1k Ohm)

Positive and negative sync of Separate Horizontal/Vertical Sync

Digital : TMDS Signal: (min) $\pm 200\text{mVpp@24Bit}$

4.2 Signal Timing

Through D-SUB/DVI connectors, this unit can support $F_H = 31.5\sim 84\text{ KHz}$, $F_v = 56\sim 76\text{ Hz}$, with maximum pixel clock 165MHz input signal and WSXGA+ output. Modes details as below:

VESA MODES							
Mode	Resolution	Total	Horizontal		Vertical		Nominal Pixel Clock (MHz)
			Nominal Frequency $\pm 0.5\text{KHz}$	Sync Polarity	Nominal Frequency $\pm 1\text{Hz}$	Sync Polarity	
VGA	640*480@60Hz		31.469	N	59.941	N	25.175
	640*480@72Hz		37.861	N	72.809	N	31.500
	640*480@75Hz		37.500	N	75.000	N	31.500
SVGA	800*600@56Hz		35.156	P	56.250	P	36.000
	800*600@60Hz		37.879	P	60.317	P	40.000
	800*600@72Hz		48.077	P	72.188	P	50.000
	800*600@75Hz		46.875	P	75.000	P	49.500
XGA	1024*768@60Hz		48.363	N	60.004	N	65.000
	1024*768@70Hz		56.476	N	70.069	N	75.000
	1024*768@75Hz		60.023	P	75.029	P	78.750
	1152*864@75Hz		67.500	P	75.000	P	108.000
	1280*960@60Hz		60.000	P	60.000	P	108.000
	1152*720@60Hz		44.859	N	59.972	P	66.750
SXGA	1280*1024@60Hz		63.981	P	60.020	P	108.000
	1280*1024@75Hz		79.976	P	75.025	P	135.000
SXGA+	1400x1050@60Hz		65.317	N	59.978	N	121.75

UXGA	1600*1200@60Hz		75.000	P	60.000	P	162.000
WXGA	1360*768@60Hz		47.712	P	60.015	P	85.5
WXGA+	1440*900(Red)@60Hz		55.469	P	59.901	N	88.75
	1440*900@75Hz		70.635	N	74.984	P	136.75
WSXGA+	1680*1050@60Hz		65.290	N	59.954	N	146.250
IBM MODES							
EGA	640*350@70Hz		31.469	P	70.087	N	25.175
	720x400@70Hz		31.469	N	70.087	P	28.322
MAC MODES							
VGA	640*480@66.7Hz		35.000	P	66.667	P	30.240
SVGA	832*624@75Hz		49.725	N	74.550	N	57.283
XGA	1024*768@75Hz		60.241	N	74.927	N	80.000
	1152*870@75Hz		68.681	N	75.062	N	100.00
Other MODES							
XGA	1024*768@72Hz		57.669	N	72.086	N	78.434
SXGA	1280*1024@70Hz		74.882	P	69.853	P	127.000

- Note: 1. Non-interlace signals only (An interlace signal cannot be display)
 2. Please refer to F/W specification for more detail
 3. Each frequency of Power Macintosh and Sun Ultra is a reference value

4.3 Timing requirements

The LCD monitor must be capable of displaying standard resolutions within the vertical frequency range of 56 ~ 76 Hz and the horizontal scan range of 31.5 ~ 84 KHz with maximum pixel clock of 190MHz.

Vertical / Horizontal Sync polarity: positive or negative.

If input signal is out of range of horizontal 31.5~84 KHz or vertical 56-76Hz, or pixel clock large than 165MHz, message "Input Not Supported" is shown on screen.

4.1 DDC data

V223W Analog

	0	1	2	3	4	5	6	7	8	9	A	B	C	D	E	F
0	00	FF	FF	FF	FF	FF	FF	00	04	72	1B	00	00	00	00	00
1	00	00	01	03	08	2F	1E	78	EA	DE	95	A3	54	4C	99	26
2	0F	50	54	BF	EF	90	A9	40	71	4F	81	40	01	01	95	00
3	95	0F	90	40	01	01	21	39	90	30	62	1A	27	40	68	B0
4	36	00	DA	28	11	00	00	19	00	00	00	FD	00	38	4D	1F
5	54	11	00	0A	20	20	20	20	20	20	00	00	00	FF	00	30
6	30	30	30	30	30	30	30	30	30	30	30	0A	00	00	00	FC
7	00	56	32	32	33	57	0A	20	20	20	20	20	20	20	00	CS

V223W DVI

	0	1	2	3	4	5	6	7	8	9	A	B	C	D	E	F
0	00	FF	FF	FF	FF	FF	FF	00	04	72	1B	00	00	00	00	00
1	00	00	01	03	80	2F	1E	78	EA	DE	95	A3	54	4C	99	26
2	0F	50	54	BF	EF	90	A9	40	71	4F	81	40	01	01	95	00
3	95	0F	90	40	01	01	21	39	90	30	62	1A	27	40	68	B0
4	36	00	DA	28	11	00	00	19	00	00	00	FD	00	38	4D	1F
5	54	11	00	0A	20	20	20	20	20	20	00	00	00	FF	00	30
6	30	30	30	30	30	30	30	30	30	30	30	0A	00	00	00	FC
7	00	56	32	32	33	57	0A	20	20	20	20	20	20	20	00	CS

5. Function Specifications

All the tests to verify specifications in this section shall be performed under the following standard conditions unless otherwise noted. The standard conditions are:

Temperature	: 25 ± 5°C
Warm-up time	: 30 minutes minimum
Checking display modes	: All the specified modes

5.1 Panel general specifications

A General specifications

Supplier	InnoLux
Model name	INL MT190AW01(V-5)
Display Area	410.4 (H) x256.5 (V)
Pixel Pitch	0.285(H) x 0.285(V)
Display Colors:	16.7 Million (6-bit + HI- FRC)
Number of Pixel	1440x900 pixels
Pixel Arrangement	RGB vertical stripe
Brightness	300cd/m ² (Typ.) 250cd/m ² (Min.)
Contrast Ratio	700:1 Typical
Viewing Angle	Hor:160°, Ver: 160° (Typical, CR>10)
Display Mode	Normally White
Frame rate	75Hz
Response Time	Tr + Tf = 5ms Typical
Surface Treatment	Anti-glare, Haze = 25%, Hard coating (3H)
Lamp	4 CCFL
Outline Dimension	427.2(W)x277.4(H)x16(D) Typ

5.2 Keypad Function

5.2.1 Control buttons on the front bezel

CONTROL KEY	KEYS FUNCTION
[AUTO]	A. When OSD un-displays, press [AUTO] to perform auto-adjustment B. When OSD displays, press [AUTO] to return to previous level menu C. When "e Color OSD" OSD displays, press [AUTO] to exit the OSD

[MENU]	<p>A. When OSD isn't shown on screen, press [MENU] to enter OSD interface. The OSD interface uses "ACER e Color Management" and "User" to instead "Contrast" and "Brightness" separately. When press "ACER e Color Management" to show "e Color OSD", and press "User" to show OSD interface before. The translations of "ACER e Color Management" and "User" are always English.</p> <p>B. When OSD displays, press [MENU] to perform function of menu icon that is highlight or enter next level menu</p>
[▶], [◀]	<p>A. When "MENU OSD" displays, press these keys to change the contents of an adjustment item, or change an adjustment value</p> <p>B. When "MENU OSD" un-displays, if it is with audio, press [▶] to show "Audio" OSD and increase the volume, press [◀] to show "Audio" OSD and decrease the volume; else it has no use to press these keys.</p>
[e Color]	<p>A. When OSD un-displays, press [e Color] to show "e Color OSD", and press again the OSD can not disappear, but the time of "e Color OSD" disappearing is reset 10 second again.</p> <p>B. When OSD disappear not including "e Color OSD", press [e Color] to show "e Color OSD" OSD, the OSD before disappears, but the parameters of it should be saved</p>
[POWER]	Power on or power off the monitor

5.3 Hot Key Operation

FUNCTION	HOT KEY OPERATION						
	AUTO	e Color	◀	▶	MENU	POWER	
FACTORY MODE		●			●	ON	Press [e Color] & [MENU] at the same time, and then press [POWER] for DC power on. OSD menu will be shown with "F" on the left top. Select "F" for entering factory mode.

5.4 OSD Structure

The On-Screen Display (OSD) shall be an easy to use icon based menu through keypad OSD buttons or remote control unit. The unit shall leave the factory with all OSD controls set to their default values.

First	Second	Third	Control Range	Default Value	
Brightness	Contrast	---	0 ~ 100	User mode	50
				Text mode	50
				Standard mode	50
				Graphics mode	60
				Movie mode	56
	Brightness	---	0 ~ 100	User mode	77
				Text mode	44
				Standard mode	77
				Graphics mode	97
				Movie mode	77

Image	Focus		---	0 ~ 100	Depend on each timing
	Clock		---	0 ~ 100	50 ϕ
Position	Horizontal		---	0 ~ 100	50
	Vertical		---	0 ~ 100	Depend on each timing
Color	Warm (6500K)		---	---	
	Cool (9300K)		---	---	
	User	Red		0 ~ 100	80
		Green		0 ~ 100	80
Blue		0 ~ 100	80		
Language	NO-EMEA	EMEA			
	English	English	---	---	English
	Deutsch	Deutsch	---	---	
	Español	Español	---	---	
	简体中文	Hollands	---	---	
	繁體中文	Русский	---	---	
	Français	Français	---	---	
	Italiano	Italiano	---	---	
日本語	Suomalainen	---	---		
OSD	Hor. Position		---	0 ~ 100	50
	Ver. Position		---	0 ~ 100	50
	OSD Timeout		---	10~ 120	20
Input (Dual)	Analog		---	---	---
	Digital		---	---	---
	DDCCI ON/OFF				ON
Input (Analg only)	DDCCI ON/OFF				ON
Info	Resolution		---	---	---
	H. Freq		---	---	---
	V. Freq		---	---	---
	S/N				ET000....0000(22)
Reset	---		---	---	---
Exit	---		---	---	---

Notes; ϕ Clock default 50 is for Visa timing. Others depend on timing.

6. SOP of firmware upgrade

6.1 Operational condition:

Equipment: PC, ISP card, signal cable and power cable.

ESD requirements: antistatic wrists, antistatic gloves (fingers), and connecting cable

Name of ISP program: RTDTool_4.6.exe

Manufacture of FW IC : RTD 2525L

6.2 Operational steps:

1. Connection: connect PC to PCBA with signal cable, and then keep AC and DC in open state.

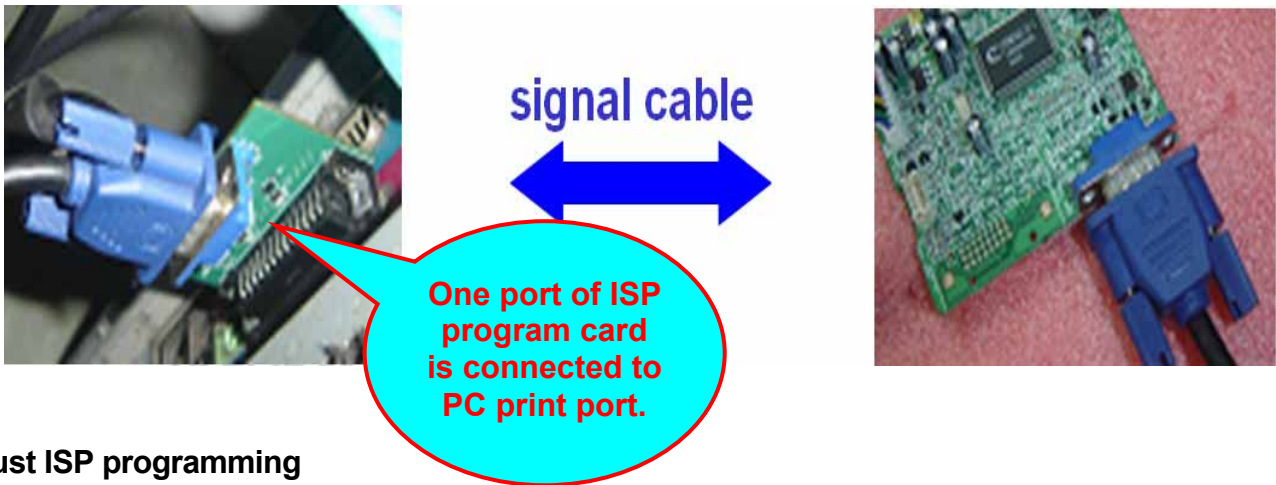

2. Adjust ISP programming

Firstly, double click ISP_Tool_v3.7.5EXE1 and open ISP program, then select “Device”, next select manufacturer model of FW IC, which should be correspondent with that of PCBA FW IC. Double click Figure One.

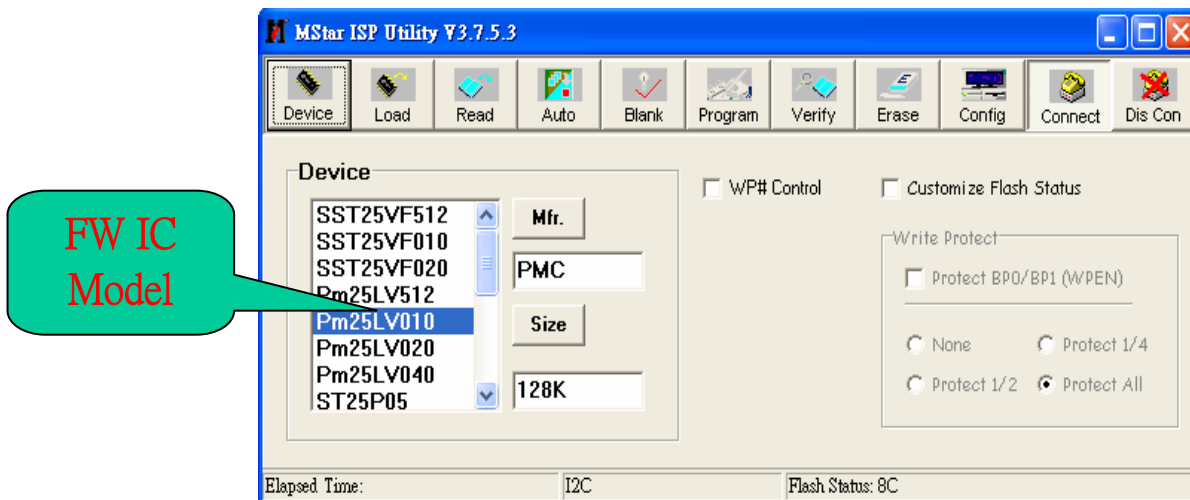

Secondly, download FW software: first select “READ”, and then load FW software in Router (Fig.2).

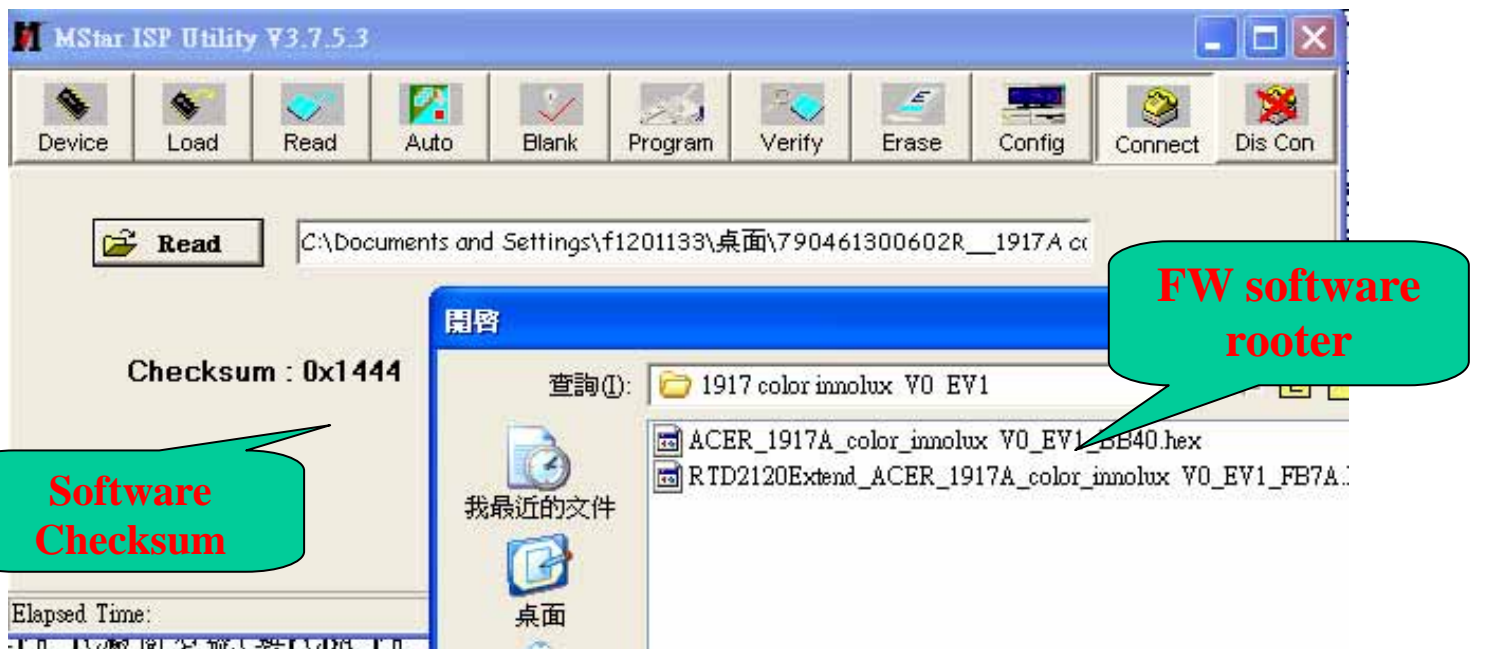

Thirdly, select “Connect” and enter ISP MODE as in the following Figure 3.

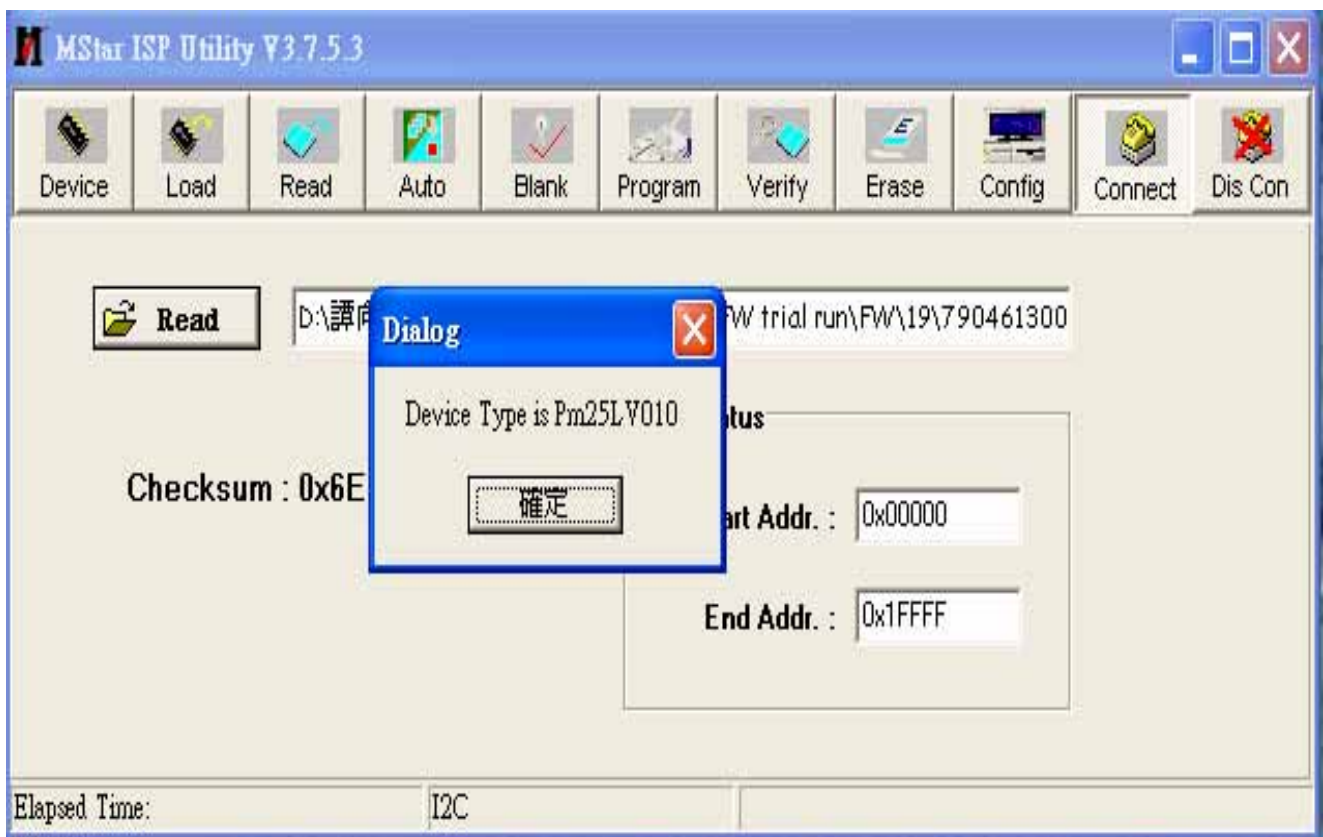

Fourthly, select “AUTO”, and keep its default value. Click “RUN” for beginning programming. There will be prompting if programming is OK.

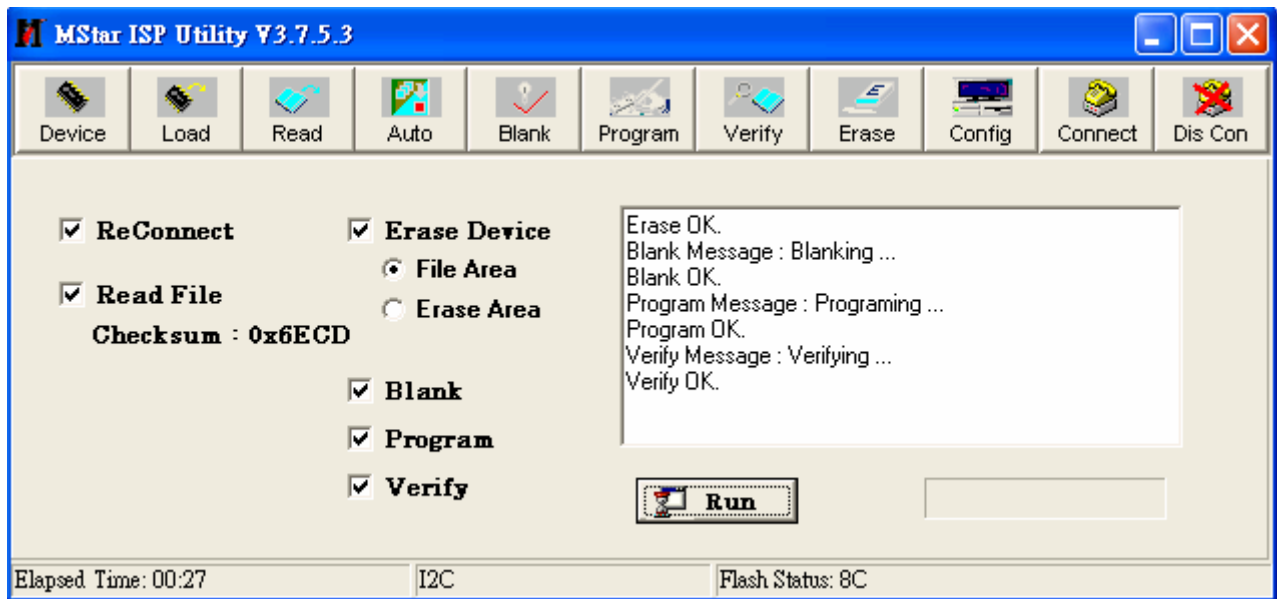

Note: if programming fails or success rate is not high, click “Config” and adjust its speed in “E2PROM DEVICE SETTING”

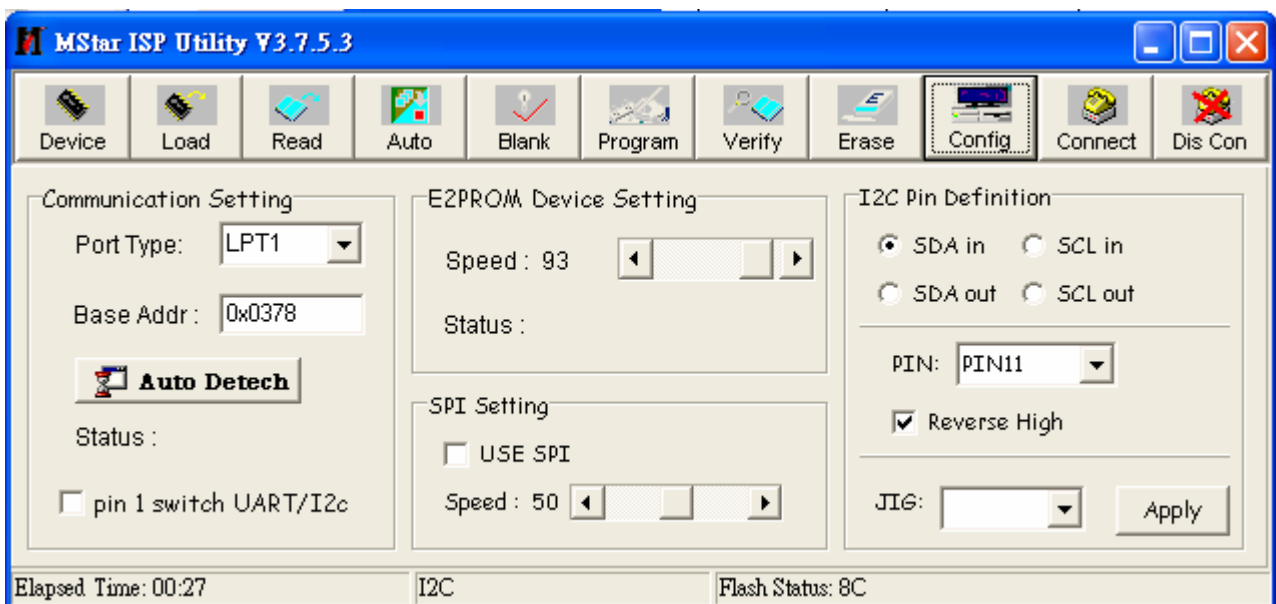

Flowing chart

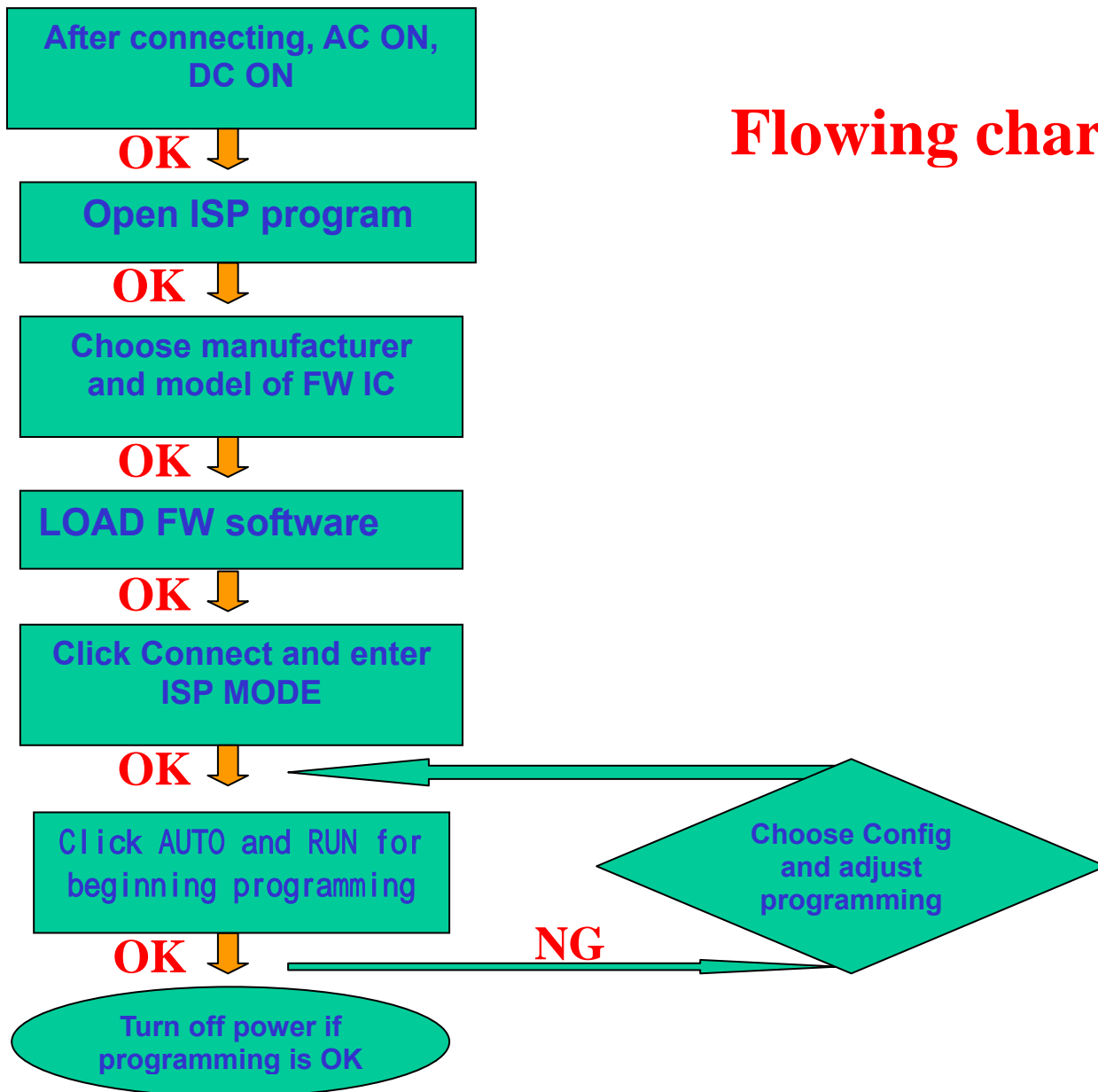

02. Flat Panel Specification

SPEC NO. MT220WW01 V.0

PAGE 4/23

A. General Specification

NO.	Item	Specification	Remark
1	Display resolution (pixel)	1680(H) X 1050(V), WSXGA+ resolution	
2	Active area (mm)	473.76(H) X 296.1(V)	
3	Screen size (inch)	22 inches diagonal	
4	Pixel pitch (mm)	0.282(H) X 0.282(V)	
5	Color configuration	R, G, B vertical stripe	
6	Overall dimension (mm)	493.7 (W) X 320.1 (H) X 16.5 (D) (typ.)	
7	Weight (g)	2900 (max.)	
8	Surface treatment	Anti-glare, Haze = 25%, Hard coating (3H)	
9	Input color signal	8 bit LVDS	
10	Display colors	16.7 M (6 bit with Hi-FRC)	
11	Optimum viewing direction	6 o'clock	
12	Backlight	4 CCFL	
13	RoHS	RoHS compliance	

Contents:	
A. General Specification	
B. Electrical Specifications	
1. Pin assignment	
2. Absolute maximum ratings	
3. Electrical characteristics	
a. Typical operating conditions	
b. Display color vs. input data signals	
c. Input signal timing	
d. Display position	
e. Backlight driving conditions	
C. Optical specifications	
D. Reliability test items	
E. Safety	
F. Display quality	
G. Handling precaution	
H. Label	
I. Mechanical drawings	
Appendix	

A. General Specification

NO.	Item	Specification	Remark
1	Display resolution (pixel)	1680(H) X 1050(V), WSXGA+ resolution	
2	Active area (mm)	473.76(H) X 296.1(V)	
3	Screen size (inch)	22 inches diagonal	
4	Pixel pitch (mm)	0.282(H) X 0.282(V)	
5	Color configuration	R, G, B vertical stripe	
6	Overall dimension (mm)	493.7 (W) X 320.1 (H) X 16.5 (D) (typ.)	
7	Weight (g)	2900 (max.)	
8	Surface treatment	Anti-glare, Haze = 25%, Hard coating (3H)	
9	Input color signal	8 bit LVDS	
10	Display colors	16.7 M (6 bit with Hi-FRC)	
11	Optimum viewing direction	6 o'clock	
12	Backlight	4 CCFL	
13	RoHS	RoHS compliance	

B. Electrical Specifications

1. Pin assignment

Connector

JAE FI-XB30SSRL-HF16, Foxconn GS23302-0311R-7F or mechanical interface equivalent connector.

Pin No.	Symbol	Description
Frame	VSS	Ground
1	RXinO0-	-LVDS differential data input, Chan 0-Odd
2	RXinO0+	+LVDS differential data input, Chan 0-Odd
3	RXinO1-	-LVDS differential data input, Chan 1-Odd
4	RXinO1+	+LVDS differential data input, Chan 1-Odd
5	RXinO2-	-LVDS differential data input, Chan 2-Odd
6	RXinO2+	+LVDS differential data input, Chan 2-Odd
7	VSS	Ground
8	RXOC-	-LVDS differential Clock input (Odd)
9	RXOC+	+LVDS differential Clock input (Odd)
10	RXinO3-	-LVDS differential data input, Chan 3-Odd
11	RXinO3+	+LVDS differential data input, Chan 3-Odd
12	RXinE0-	-LVDS differential data input, Chan 0-Even
13	RXinE0+	+LVDS differential data input, Chan 0-Even
14	VSS	Ground
15	RXinE1-	-LVDS differential data input, Chan 1-Even
16	RXinE1+	+LVDS differential data input, Chan 1-Even
17	VSS	Ground
18	RXinE2-	-LVDS differential data input, Chan 2-Even
19	RXinE2+	+LVDS differential data input, Chan 2-Even
20	RXEC-	-LVDS differential Clock input (Even)
21	RXEC+	+LVDS differential Clock input (Even)
22	RXinE3-	-LVDS differential data input, Chan 3-Even
23	RXinE3+	+LVDS differential data input, Chan 3-Even
24	VSS	Ground
25	VSS	Ground
26	NC	No Connection
27	VSS	Ground
28	VCC	+5.0V power supply
29	VCC	+5.0V power supply
30	VCC	+5.0V power supply
Frame	VSS	Ground

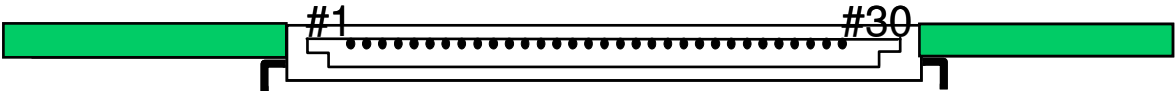
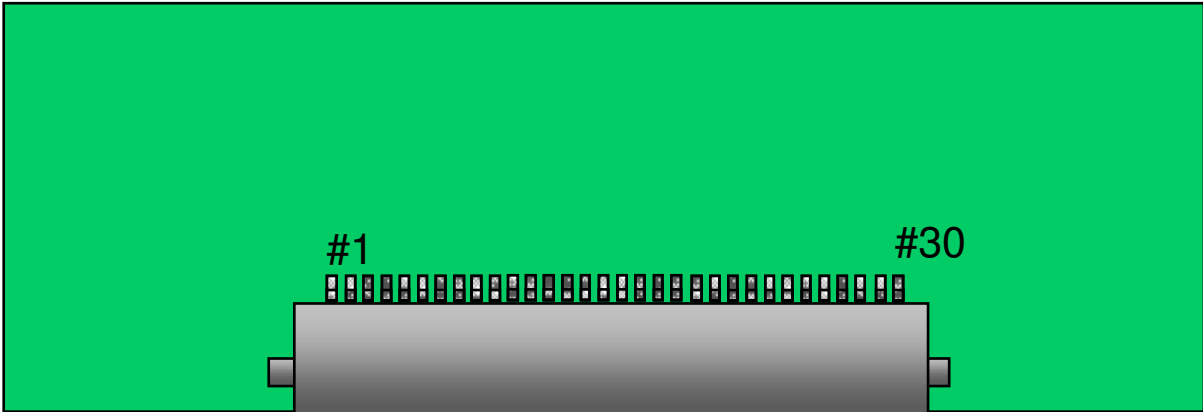

Rear view of LCM

2. Absolute maximum ratings

Parameter	Symbol	Values		Unit	Remark
		Min.	Max.		
Power voltage	V_{cc}	-0.3	6	V	At 25°C
Input signal voltage	V_{LH}	-0.3	4.3	V	At 25°C
Operating temperature	T_{op}	0	50	°C	Note 1
Storage temperature	T_{ST}	- 25	60	°C	Note 2
CCFL Current	ICFL	3	8	[mA]	

Note 1: The relative humidity must not exceed 90% non-condensing at temperatures of 40°C or less. At temperatures greater than 40°C, the wet bulb temperature must not exceed 39°C.

Note 2: The unit should not be exposed to corrosive chemicals.

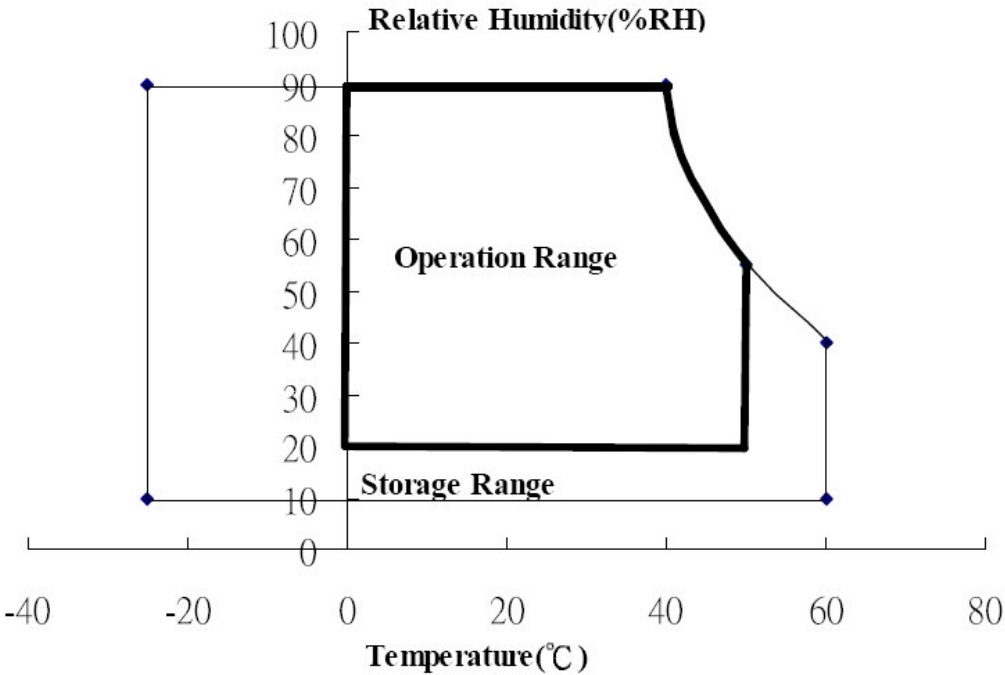

3. Electrical characteristics

a. Typical operating conditions

Item		Symbol	Min.	Typ.	Max.	Unit	Remark
Input Voltage		V_{cc}	4.5	5	5.5	V	
Permissive Power Input Ripple		V_{RF}	-	-	0.25	V	
Input Current	Black	I_{cc}	-	900	-	mA	Note 1
	White	I_{cc}	-	700	-		Note 2
	Mosaic	I_{cc}	-	800	-		Note 3
Rush Current		I_{Rush}	-	-	4	A	Note 4
Logic Input	Common Mode Voltage	VCM	-	1.2	-	V	
Voltage LVDS:	Differential Input Voltage	VID	100	-	600	mV	
	Threshold Voltage (High)	VTH	-	-	100	mV	Note 5
IN+, IN-	Threshold Voltage (Low)	VTL	-100	-	-	mV	Note 5

Note 1 : The specified current is under the $V_{cc} = 5V$, $25^{\circ}C$, $fv=60Hz$ (frame frequency) condition whereas black pattern is displayed.

Note 2 : The specified current is under the $V_{cc} = 5V$, $25^{\circ}C$, $fv=60Hz$ (frame frequency) condition whereas white pattern is displayed.

Note 3 : The specified current is under the $V_{cc} = 5V$, $25^{\circ}C$, $fv=60Hz$ (frame frequency) condition whereas mosaic pattern(black & white [8*6]) is displayed.

White : 255 Gray

Black : 0 Gray

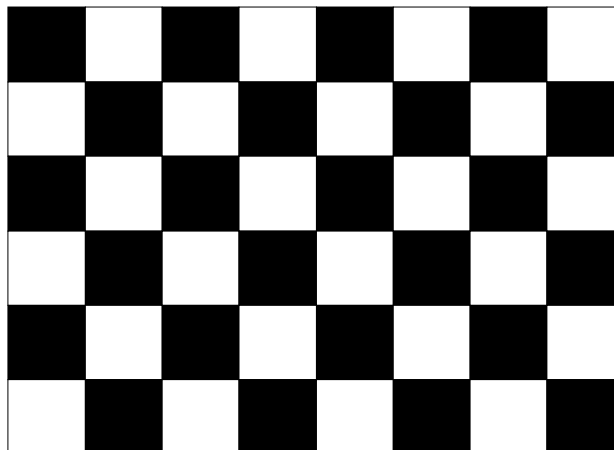

Note 4 : test condition :

- (1) $V_{DD} = 5\text{ V}$, V_{DD} rising time = $470\ \mu\text{s} \pm 10\%$
- (2) Pattern: Mosaic pattern

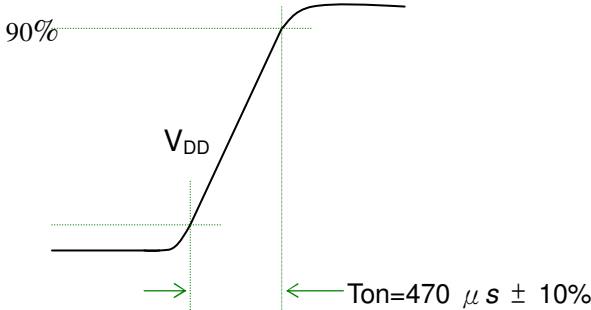

(3) Test circuit

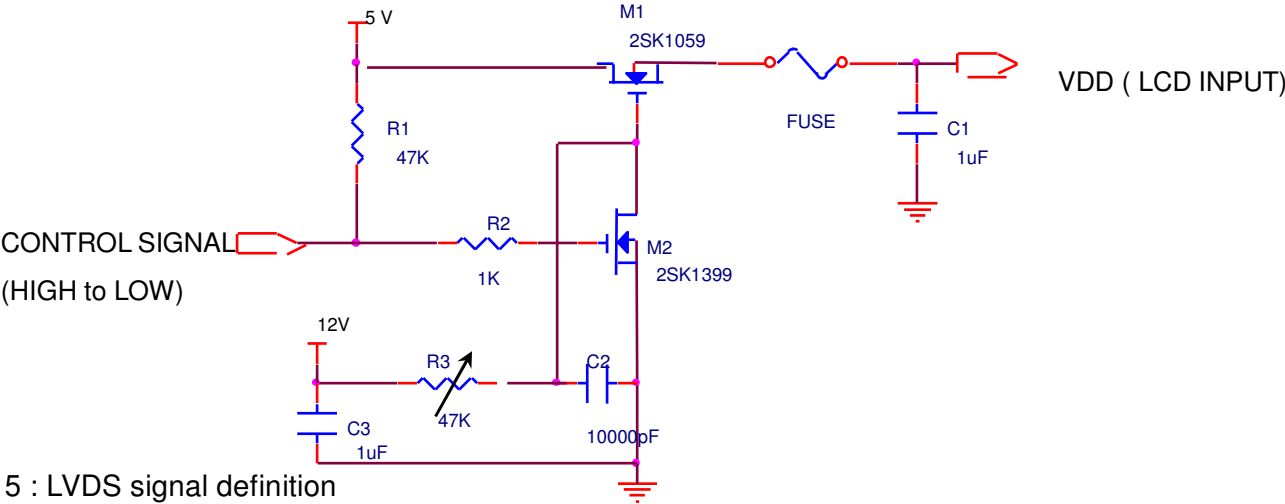

Note 5 : LVDS signal definition

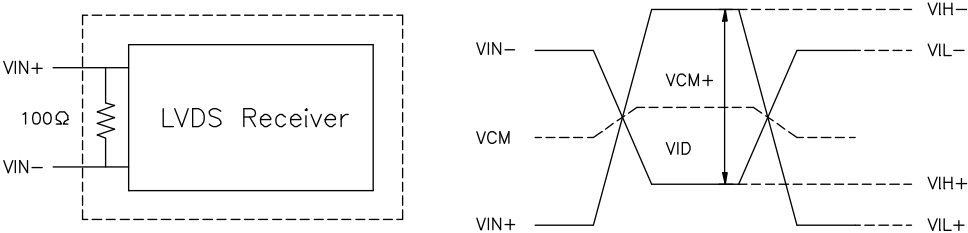

- VIN_+ = Positive differential DATA & CLK Input
- VIN_- = Negative differential DATA & CLK Input
- $VID = VIN_+ - VIN_-$,
- $\Delta VCM = | VCM_+ - VCM_- |$,
- $\Delta VID = | VID_+ - VID_- |$,
- $VID_+ = | VIH_+ - VIH_- |$,
- $VID_- = | VIL_+ - VIL_- |$,
- $VCM = (VIN_+ + VIN_-)/2$,
- $VCM_+ = (VIH_+ + VIH_-)/2$,
- $VCM_- = (VIL_+ + VIL_-)/2$,

Note 6 : Power on sequence for LCD V_{DD}

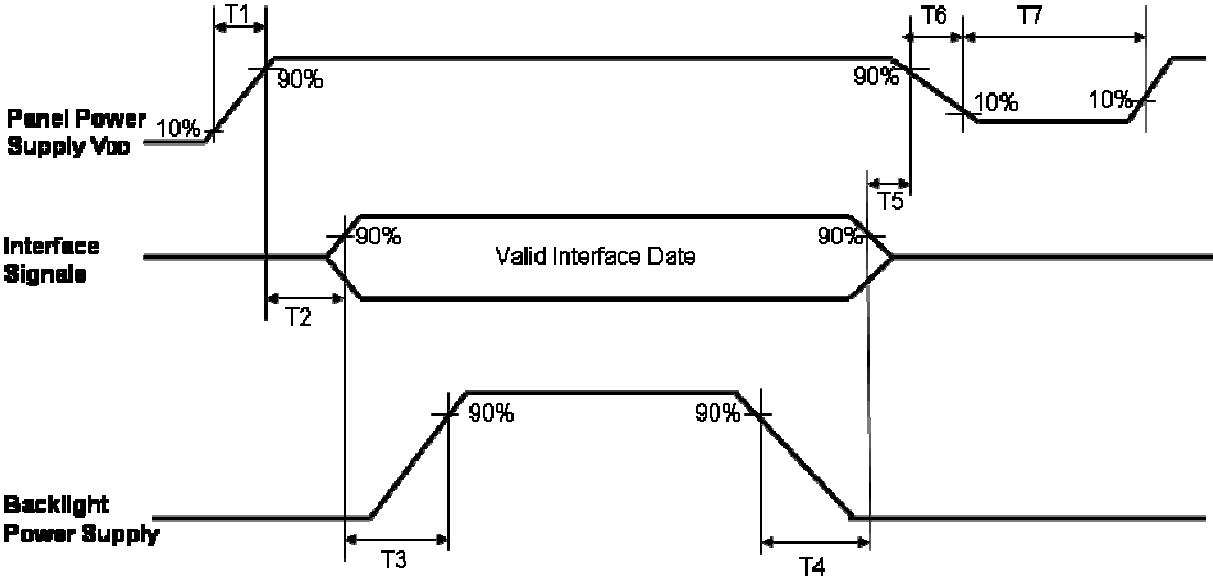

Parameter	Value			Unit
	Min.	Typ.	Max.	
T1	0.1	--	10	ms
T2	0	--	50	ms
T3	200	250	--	ms
T4	100	250	--	ms
T5	0	20	50	ms
T6	0.1	--	--	ms
T7	1000	--	--	ms

b. Display color vs. input data signals

The brightness of each primary color (red, green and blue) is based on the 8-bit gray scale data input for the color; the higher the binary input, the brighter the color. The table below provides a reference for color versus data input.

Color		Input color data																							
		Red								Green								Blue							
		MSB				LSB				MSB				LSB				MSB				LSB			
		R7	R6	R5	R4	R3	R2	R1	R0	G7	G6	G5	G4	G3	G2	G1	G0	B7	B6	B5	B4	B3	B2	B1	B0
Basic colors	Black	0	0	0	0	0	0	0	0	0	0	0	0	0	0	0	0	0	0	0	0	0	0	0	0
	Red(255)	1	1	1	1	1	1	1	1	0	0	0	0	0	0	0	0	0	0	0	0	0	0	0	0
	Green(255)	0	0	0	0	0	0	0	0	1	1	1	1	1	1	1	1	0	0	0	0	0	0	0	0
	Blue(255)	0	0	0	0	0	0	0	0	0	0	0	0	0	0	0	0	1	1	1	1	1	1	1	1
	Cyan	0	0	0	0	0	0	0	0	1	1	1	1	1	1	1	1	1	1	1	1	1	1	1	1
	Magenta	1	1	1	1	1	1	1	1	0	0	0	0	0	0	0	0	1	1	1	1	1	1	1	1
	Yellow	1	1	1	1	1	1	1	1	1	1	1	1	1	1	1	1	0	0	0	0	0	0	0	0
	White	1	1	1	1	1	1	1	1	1	1	1	1	1	1	1	1	1	1	1	1	1	1	1	1
Red	Red(000) dark	0	0	0	0	0	0	0	0	0	0	0	0	0	0	0	0	0	0	0	0	0	0	0	0
	Red(001)	0	0	0	0	0	0	0	1	0	0	0	0	0	0	0	0	0	0	0	0	0	0	0	0
	Red(002)	0	0	0	0	0	0	1	0	0	0	0	0	0	0	0	0	0	0	0	0	0	0	0	0
	:	:	:	:	:	:	:	:	:	:	:	:	:	:	:	:	:	:	:	:	:	:	:	:	:
	Red(253)	1	1	1	1	1	1	0	1	0	0	0	0	0	0	0	0	0	0	0	0	0	0	0	0
	Red(254)	1	1	1	1	1	1	1	0	0	0	0	0	0	0	0	0	0	0	0	0	0	0	0	0
	Red(255) bright	1	1	1	1	1	1	1	1	0	0	0	0	0	0	0	0	0	0	0	0	0	0	0	0
Green	Green(000)dark	0	0	0	0	0	0	0	0	0	0	0	0	0	0	0	0	0	0	0	0	0	0	0	0
	Green(001)	0	0	0	0	0	0	0	0	0	0	0	0	0	0	1	0	0	0	0	0	0	0	0	0
	Green(002)	0	0	0	0	0	0	0	0	0	0	0	0	0	1	0	0	0	0	0	0	0	0	0	0
	:	:	:	:	:	:	:	:	:	:	:	:	:	:	:	:	:	:	:	:	:	:	:	:	:
	Green(253)	0	0	0	0	0	0	0	1	1	1	1	1	1	1	0	1	0	0	0	0	0	0	0	0
	Green(254)	0	0	0	0	0	0	0	1	1	1	1	1	1	1	1	0	0	0	0	0	0	0	0	0
	Green(255)bright	0	0	0	0	0	0	0	1	1	1	1	1	1	1	1	1	0	0	0	0	0	0	0	0
Blue	Blue(000) dark	0	0	0	0	0	0	0	0	0	0	0	0	0	0	0	0	0	0	0	0	0	0	0	0
	Blue(001)	0	0	0	0	0	0	0	0	0	0	0	0	0	0	0	0	0	0	0	0	0	0	0	1
	Blue(002)	0	0	0	0	0	0	0	0	0	0	0	0	0	0	0	0	0	0	0	0	0	0	1	0
	:	:	:	:	:	:	:	:	:	:	:	:	:	:	:	:	:	:	:	:	:	:	:	:	:
	Blue(253)	0	0	0	0	0	0	0	0	0	0	0	0	0	0	0	1	1	1	1	1	1	1	0	1
	Blue(254)	0	0	0	0	0	0	0	0	0	0	0	0	0	0	0	1	1	1	1	1	1	1	1	0
	Blue(255) bright	0	0	0	0	0	0	0	0	0	0	0	0	0	0	0	1	1	1	1	1	1	1	1	1

c. Input signal timing

Support Input Timing Table

The input signal timing specifications are shown as the following table and timing diagram.

Signal	Item	Description	Min.	Typ.	Max.	Unit
Clock	Dclk	period	12.2	16.8	17.9	nS
		frequency	56	59.6	82	MHz
Vertical	T_{V_TOTAL}	V total line number	1059	1080	1100	T_H
	T_{V_DATA}	Data duration	1050	1050	1050	T_H
	T_{VB}	V-blank	9	30	50	T_H
	f_V	frequency	56	60	76	Hz
Horizontal	T_{H_TOTAL}	H total pixel number	890	920	1004	DCIk
	T_{H_DATA}	Data duration	840	840	840	DCIk
	T_{HB}	H-blank	73	80	164	DCIk

Note: Because this module is operated by DE only mode, Hsync and Vsync input signals should be set to low logic level or ground. Otherwise, this module would operate abnormally.

INPUT SIGNAL TIMING DIAGRAM

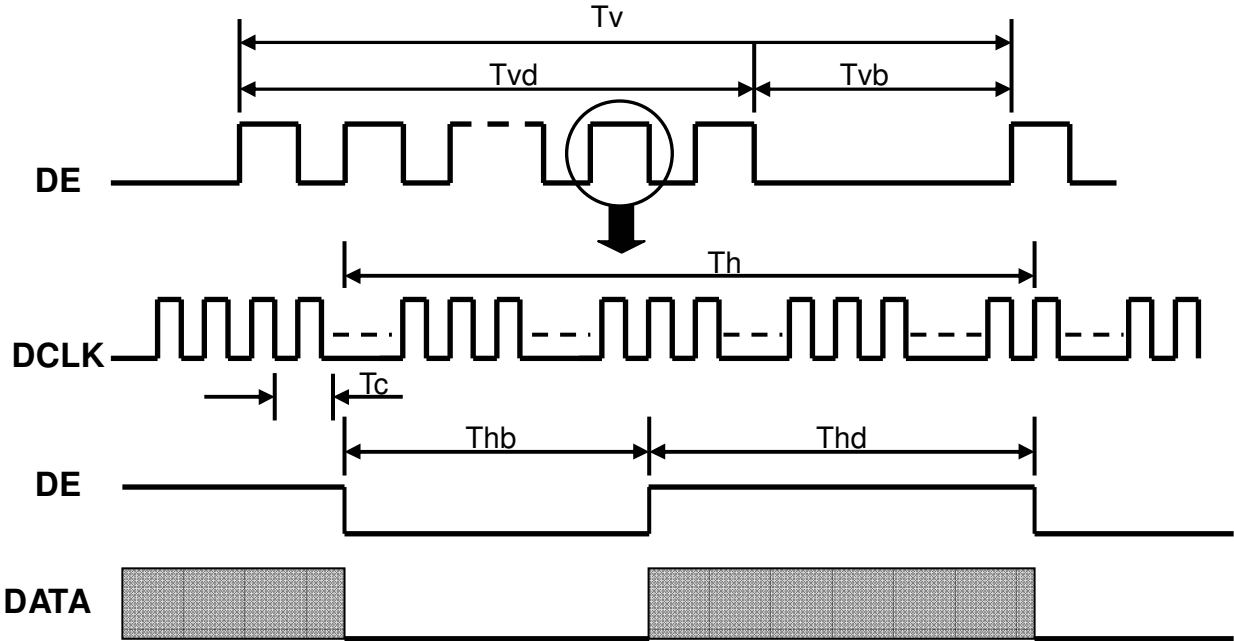

d. Display Position

D(1, 1)	D(2, 1)	D(840, 1)	D(1679, 1)	D(1680, 1)
D(1, 2)	D(2, 2)	D(840, 2)	D(1679, 2)	D(1680, 2)
⋮		⋮	⋮	⋮
D(1, 525)	D(2, 525)	D(840, 525)	D(1679, 525)	D(1680, 525)
⋮		⋮	⋮	⋮
D(1, 1049)	D(2, 1049)	D(840, 1049)	D(1679, 1049)	D(1680, 1049)
D(1, 1050)	D(2, 1050)	D(840, 1050)	D(1679, 1050)	D(1680, 1050)

e. Backlight driving conditions

Parameter	Symbol	Min.	Typ.	Max.	Unit	Remark	Remark
Lamp voltage	VL	758(8mA)	794(7mA)	955(3mA)	Vrms		
Lamp operation current	IL	3	7	8	mArms		Note 1
Lamp starting voltage	VLstart			1250	Vrms	T = 25 °C	Note 2,3,4,5
				1570		T = 0 °C	Note 2,3,4,5
Frequency	F	40	55	80	KHZ		Note 5
Lamp life time		40000			Hr		Note 6

Note: The waveform of the voltage output of inverter must be area-symmetric and the design of the inverter must have specifications for the modularized lamp. The performance of the Backlight, such as lifetime or brightness, is greatly influenced by the characteristics of the DC-AC inverter for the lamp. All the parameters of an inverter should be carefully designed to avoid producing too much current leakage from high voltage output of the inverter. When designing or ordering the inverter please make sure that a poor lighting caused by the mismatch of the Backlight and the inverter (miss-lighting, flicker, etc.) never occurs. If the above situation is confirmed, the module should be operated in the same manners when it is installed in your instrument.

Note 1 :

The degree of unbalance: less than 10%
 The ratio of wave height: less than $\sqrt{2} \pm 10\%$

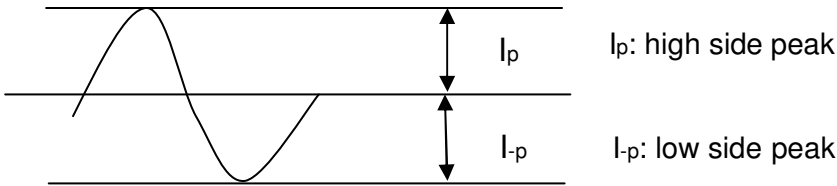

The degree of unbalance = $|I_p - I-p| / I_{rms} * 100(\%)$
 The ratio of wave height = $I_p(\text{or } I-p) / I_{rms}$
 Lamp should be completely turned on.

Note 2: Test equipment: AS-114B

Note 3: The voltage shown above should be applied to the lamp for more than 1 second after startup. Otherwise, the lamp may not be turned on normally.

Note 4: Inverter should provide more than min. value, and then lamp could be completely turned on.

Note 5: Lamp frequency may produce interference with horizontal synchronous frequency and this may cause line flow on the display. Therefore lamp frequency shall be detached from the horizontal synchronous frequency and its harmonics as far as possible in order to avoid interference.

Note 6: Lamp life definition: The brightness of lamp becomes 50% of the initial brightness or not normal lighting.

Backlight connector : 35001HS-02L

Pin no.	Symbol	Function	Remark
1	VIH	Lamp high voltage input	Cable color: Pink
2	VIL	Lamp low voltage input	Cable color: White
3	VIH	Lamp high voltage input	Cable color: Blue
4	VIL	Lamp low voltage input	Cable color: Black

C. Optical Specifications

Item	Symbol	Condition	Specification			Unit	Remark
			Min.	Typ.	Max.		
Response time	Tr	$\theta = 0^\circ$		1.5	3	ms	Note 4
	Tf			3.5	7		
	Tr+Tf			5	10		
Contrast ratio	CR	$\theta = 0^\circ$	700	1000			Note 3,5
Viewing angle	Top	$CR \geq 10$	70	80	deg.	Note 3,5,7	
		$CR \geq 5$	75	85			
	Bottom	$CR \geq 10$	70	80			
		$CR \geq 5$	75	85			
Left	$CR \geq 10$	75	85				
	$CR \geq 5$	80	89				
Right	$CR \geq 10$	75	85				
	$CR \geq 5$	80	89				
Brightness (Center)	YL		250	300	nit	Note 3,6	
Color chromaticity(CIE)	Wx	$\theta = 0^\circ$	-0.03	0.313	+0.03	Note 3	
	Wy			0.329			
	Rx			0.640			
	Ry			0.349			
	Gx			0.284			
	Gy			0.617			
	Bx			0.142			
	By			0.067			
White uniformity (9 points)	δw		0.75	0.80		Note 3,8	
Cross talk	Ct				2%	Note 9	

Note 1: Ambient temperature = 25°C.

Note 2: To be measured in dark room after backlight warm up 30 minutes.

Note 3: To be measured with a viewing cone of 2° by Topcon luminance meter BM-5A.

Note 4: Definition of response time: The output signals of BM-7 are measured when the input signals are changed from “Black” to “White” (falling time) and from “White” to “Black” (rising time), respectively. The response time interval is between the 10% and 90% of amplitudes. Refer to figure as below :

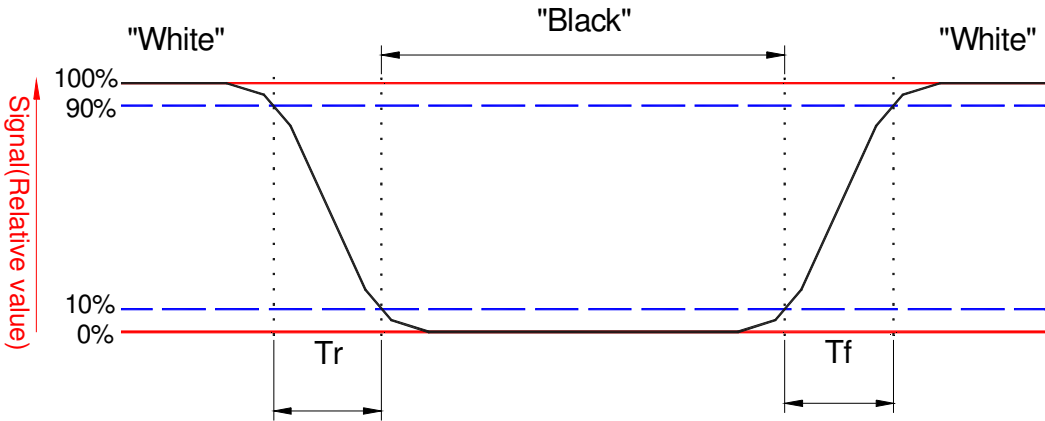

Note 5: Definition of contrast ratio:

Contrast ratio is calculated by the following formula.

$$\text{Contrast ratio (CR)} = \frac{\text{Brightness on the "white" state}}{\text{Brightness on the "black" state}}$$

Note 6: Driving conditions for CCFL: $I_L = 7\text{mA}$, 50 KHz Frequency.

Note 7: Definition of viewing angle.

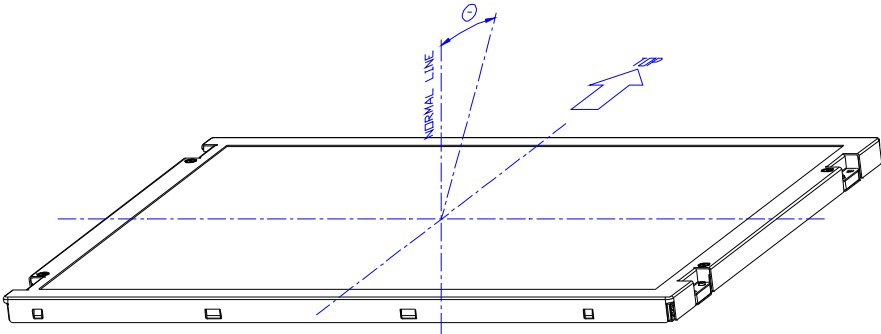

Note 8: Definition white uniformity:

Luminance are measured at the following nine points (P1~P9).

$$\delta_w = \frac{\text{Minimum Brightness of nine points (P1~P9)}}{\text{Maximum Brightness of nine points (P1~P9)}}$$

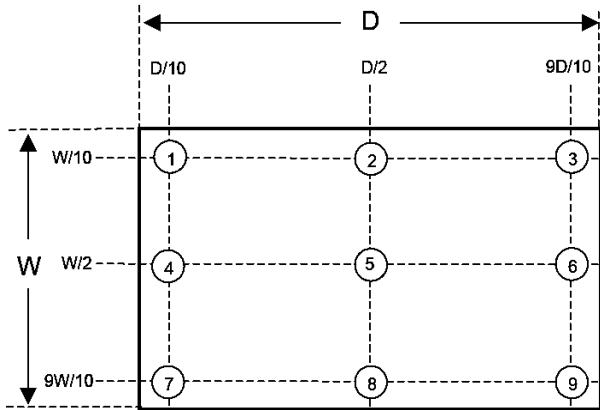

Note 9:

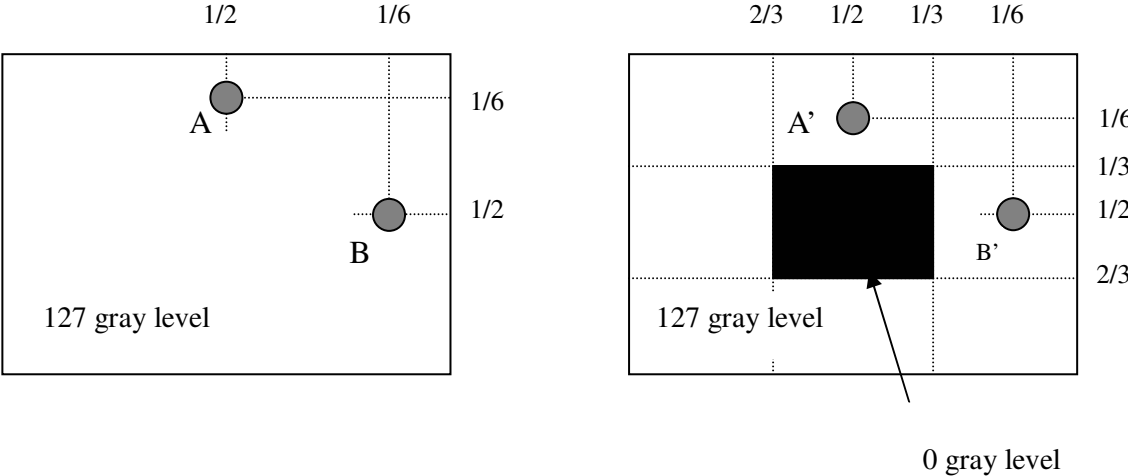

$|L_A - L_{A'}| / L_A \times 100\% = 2\% \text{ max.}$, L_A and $L_{A'}$ are brightness at location A and A'
 $|L_B - L_{B'}| / L_B \times 100\% = 2\% \text{ max.}$, L_B and $L_{B'}$ are brightness at location B and B'

Note 10: Optical characteristic measurement setup.

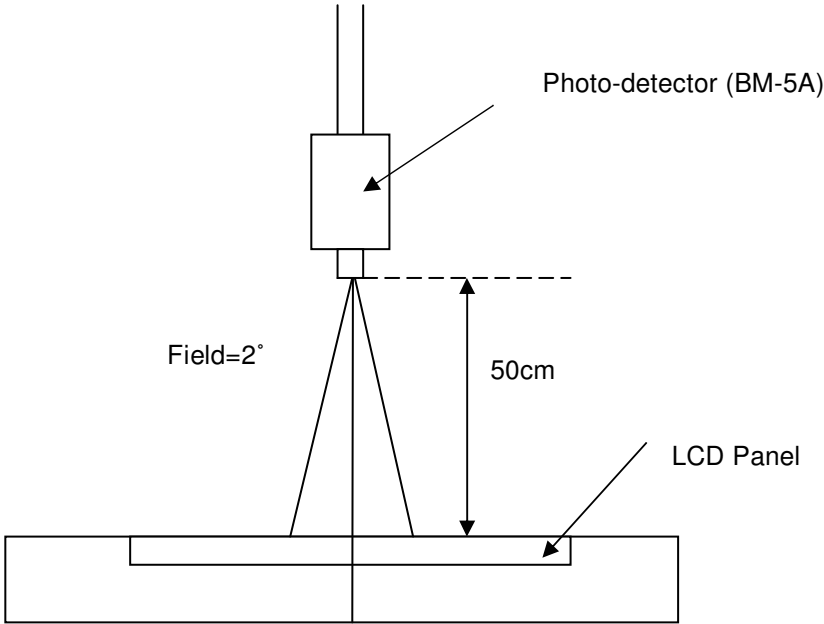

D. Reliability test items

Test Item	Test Condition	Judgment	Remark
High temperature storage	60°C, 240Hrs	Note 1	Note 2
Low temperature storage	-25°C, 240Hrs	Note 1	Note 2
High temperature & high humidity operation	40°C, 90%RH, 240Hrs (No condensation)	Note 1	Note 2
High temperature operation	50°C, 240Hrs	Note 1	Note 2
Low temperature operation	0°C, 240Hrs	Note 1	Note 2
Thermal Shock (non-operation)	-20°C~60°C 1Hr, 10mins, 1Hr, 100cycles	Note 1	Note 2
Electrostatic discharge (ESD) (non-operation)	Contact: +/-8kV, 150pF(330ohms), 25 times/1 point, 1 time/1 sec Air discharge: +/-15kV, 150pF(330ohms), 25 times/1 point, 1 time/1 sec	Note 1	Note 2
Vibration (non-operation)	Vibration level : 1.5G Bandwidth : 10-300Hz Waveform : sine wave, sweep rate : 10min 30 min for each direction X, Y, Z (1.5 Hrs in total)	Note 1	Note 2
Mechanical Shock (non-operation)	Shock level : 50G, 11ms Waveform : Half sine wave Direction : ±X, ±Y, ±Z One time each direction	Note 1	Note 2
MTBF Demonstration	40,000 hours with confidence level 90%	Note 1	Note 3

Note1: Pass: Normal display image with no obvious non-uniformity and no line defect. Partial transformation of the module parts should be ignored.

Fail: No display image, obvious non-uniformity, or line defects.

Note2: Evaluation should be tested after storage at room temperature for one hour.

Note 3: The MTBF (exclude the CCFL) calculation is based on the assumption that the failure rate distribution meets the Exponential Model.

E. Safety

1. Sharp Edge Requirements

There will be no sharp edges or corners on the display assembly that could cause injury.

2. Materials

a. Toxicity

There will be no carcinogenic materials used anywhere in the display module. If toxic materials are used, they will be reviewed and approved by the responsible InnoLux Toxicologist.

b. Flammability

All components including electrical components that do not meet the flammability grade UL94-V1 in the module will complete the flammability rating exception approval process. The printed circuit board will be made from material rated 94-V1 or better. The actual UL flammability rating will be printed on the printed circuit board.

c. Capacitors

If any polarized capacitors are used in the display assembly, provisions will be made to keep them from being inserted backwards.

F. Display quality

The display quality of the color TFT-LCD module should be in compliance with the Innolux's Incoming inspection standard.

G. Handling precaution

The Handling of the TFT-LCD should be in compliance with the Innolux's handling principle standard.

03 Exploded Diagram

3.1 Screw List

Item	Part No.	Description	Qty	Fixed T(kg*cm)	Remark
1	509146306102R	SCREW P CROSS W/W-SPR M3*6 Zn	2	3.75±0.25	FOR POWER
2	509000000700R	BOLT,#4-40x11.8,Ni	4	4.0 ± 0.25	D-SUB CON&DVI
3	50911661210 2R	SCREW,P,CROSS,M4*12,BLK-Zn,RO HS(NYLOK)	4	10.5±0.25	For back-cover to STAND ASSY
4	509146306200R	SCREW P CROSS W/WAS M3*6 ZN-Cc	5	3.75±0.25	FOR POWER&IF

3.2. LCD Exploded drawing (All)

12	509146306102R	SCREW P CROSS W/W SPR M3*6 Zn	1	
11	50940000700R	BOLT #4-40x11.8 Ni	4	
10	714020015500R	ASSY.BASE,B223WLE22D2	1	
9	714020015500R	SCREW B M4*12	4	
8	714011202700R	ASSY.STAND,B223WLE22D2	1	
7	714050014200R	ASSY.BACK COVER W/DV INL,B223WLE22D2	1	
6	502090310310R	CHASSIS W/DV1,B223WLE22D2	1	
5	509146306200R	POWER BOARD	1	
4	509146306200R	SCREW P CROSS W/W WAS M3*6 Zn+cc	6	
3		IF BOARD	1	
2		PANEL	1	
1	714030015500R	ASSY.BEZEL FRONT,(silver),B223WLE22D2	1	
ITEM	PART NO	PART DESCRIPTION	QTY	
	14	KEYPAD	1	
	13	PART NO	PART DESCRIPTION	QTY

MODEL NO	LE22D2	DATE	
TITLE	LE22D2(B223W) EXPLODE -DRAWING		
DRAWN		CHECKED	
SIGNATURE		ASSUED	
PART NO	AQ	PAGE NO	1
SCALE		SHEET	1
FDCOMM CORP. (INNOVIX)			

ZONE	REV	DESCRIPTION	DATE	APPROVED

04 Troubleshooting

1. No Power & LED Off

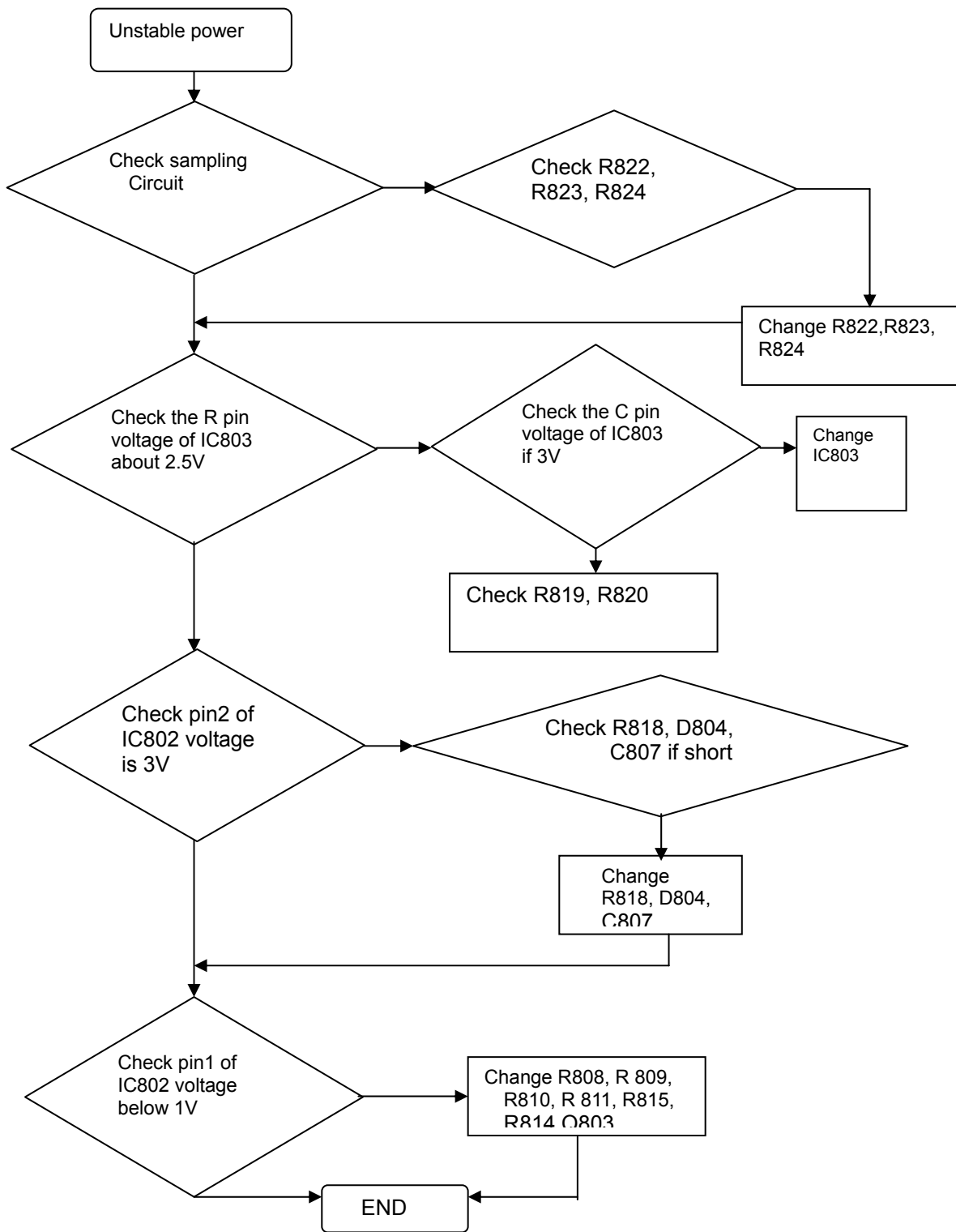

2. No raster

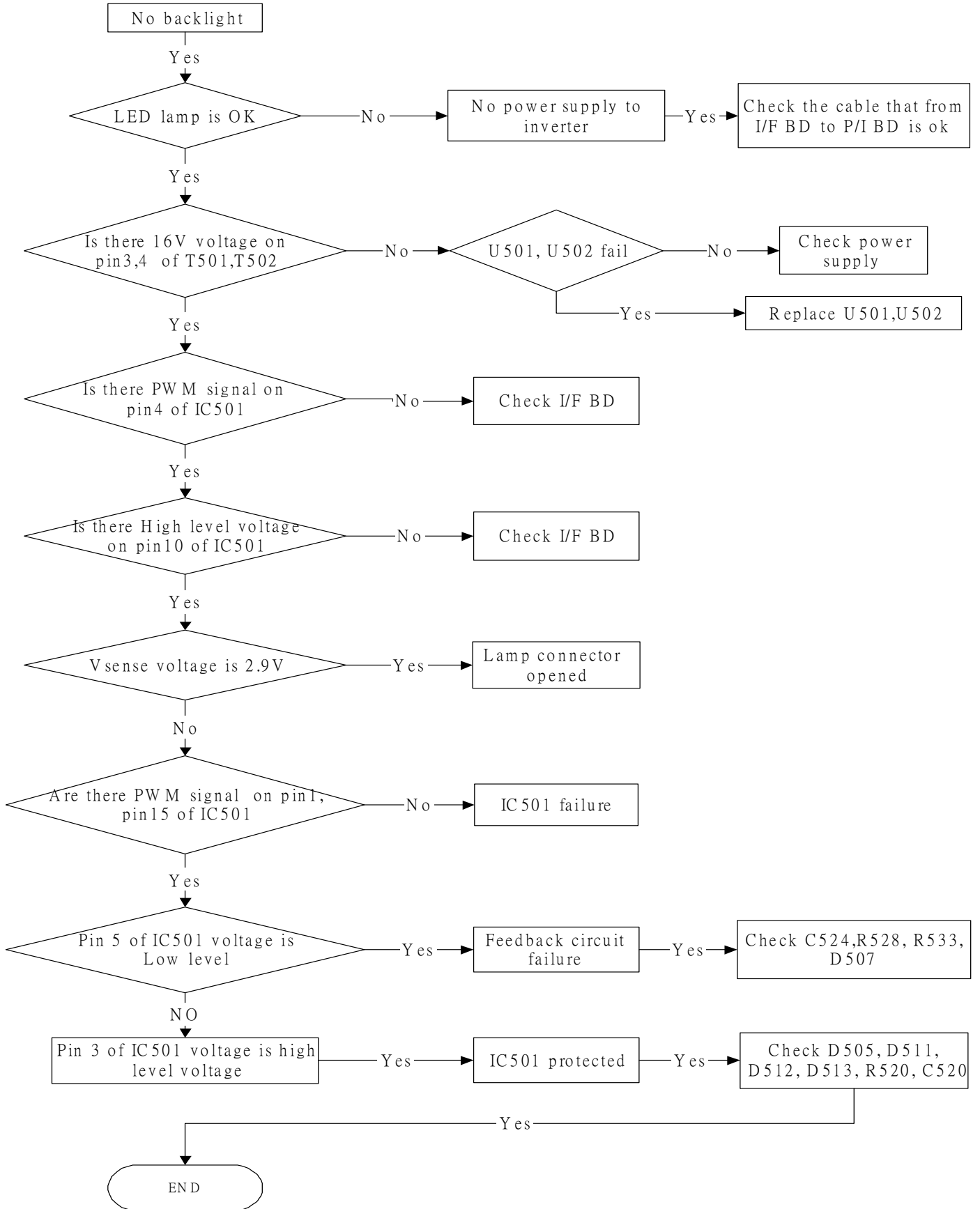

3.Black screen

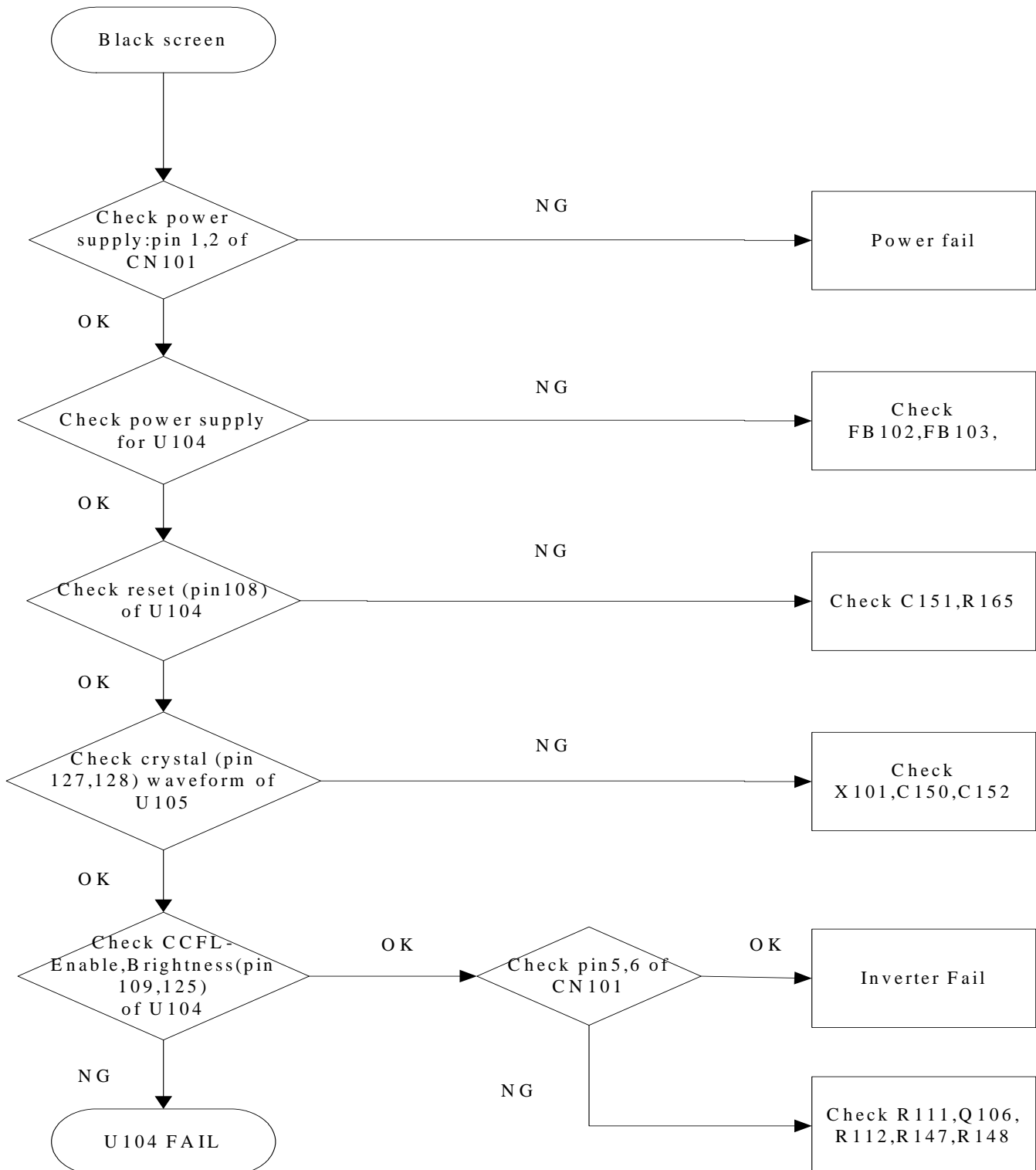

4.Bad Screen

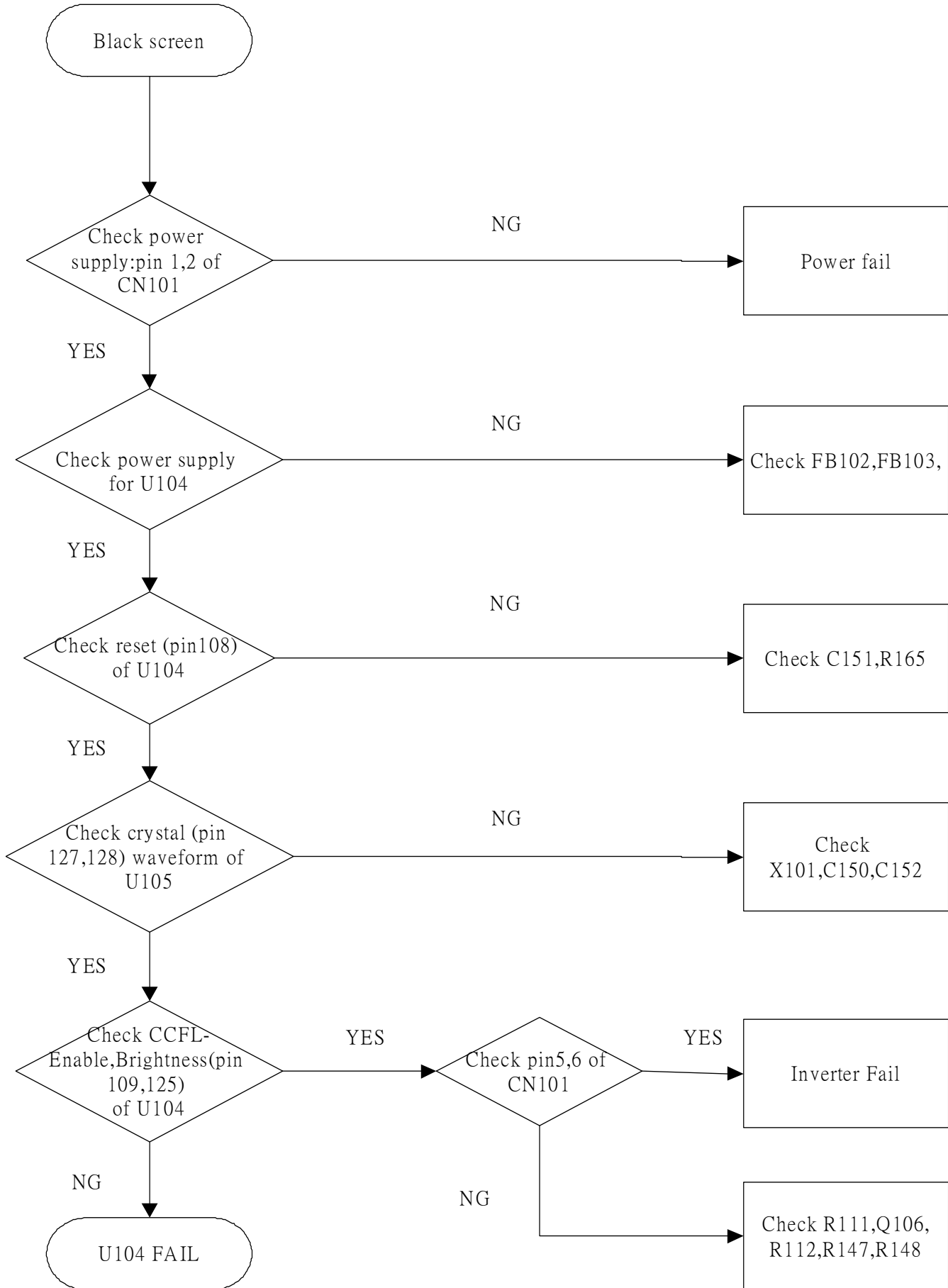

5. White screen

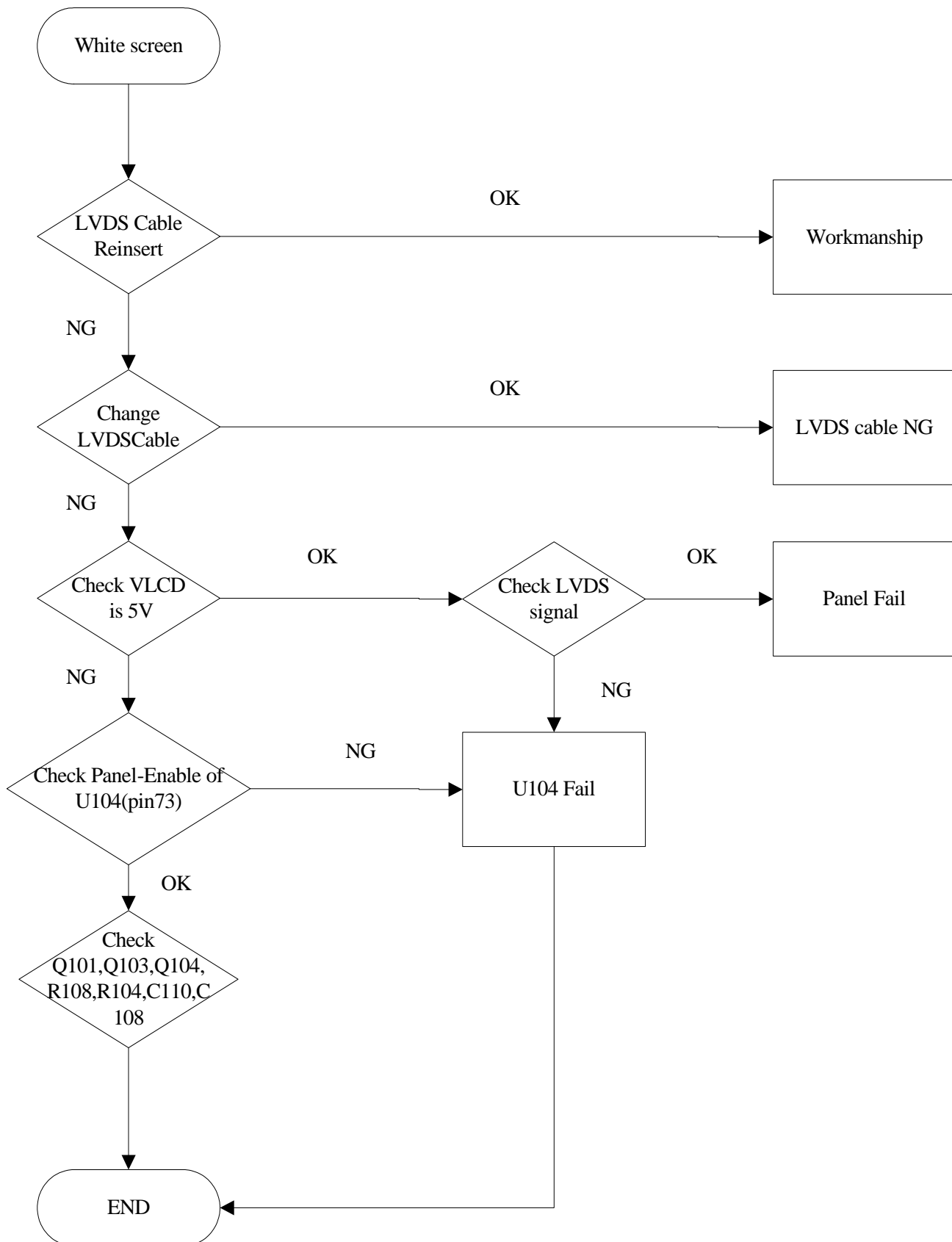

6. No Sound

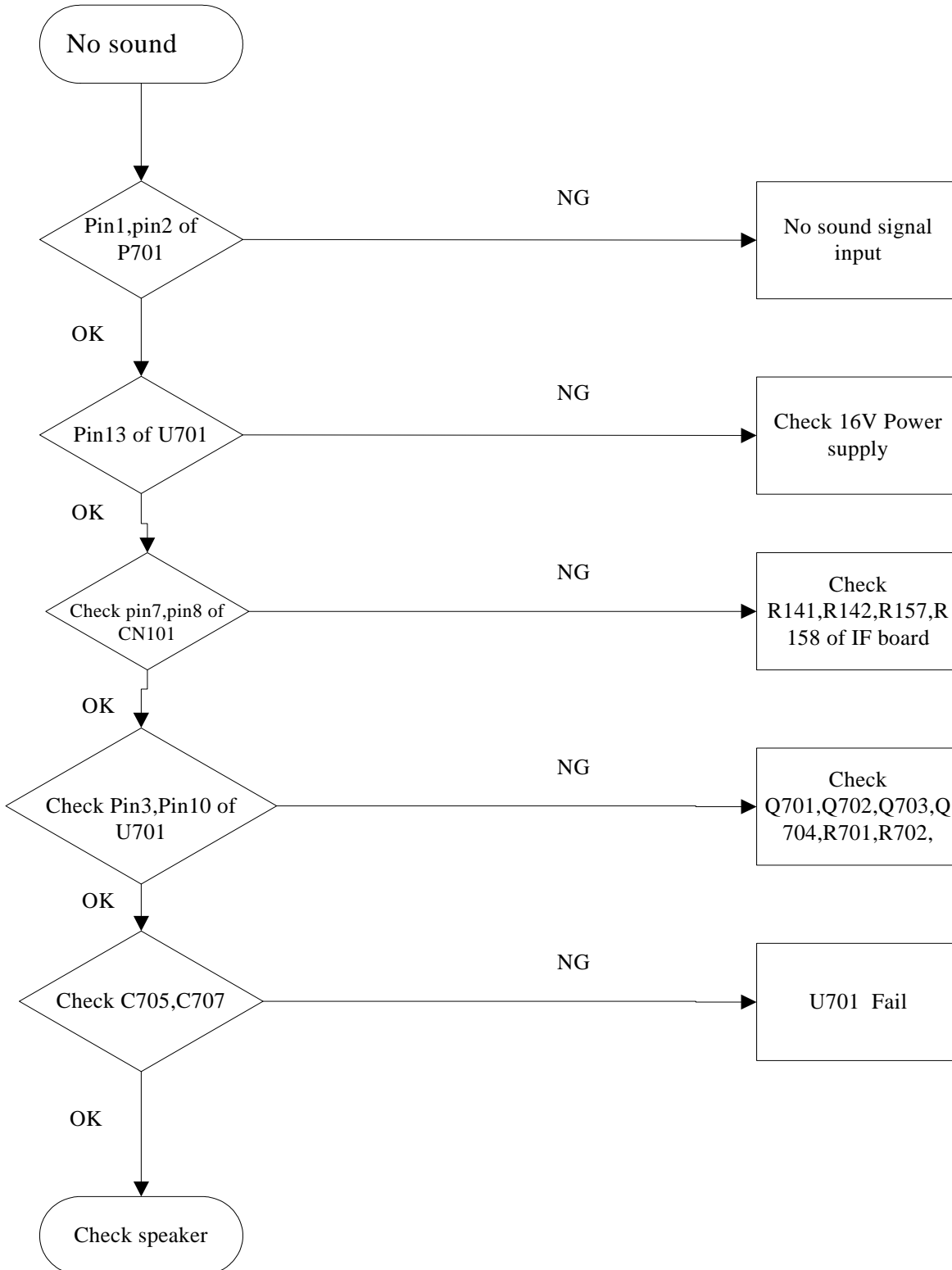

05 Spare parts List

		8221D271A1E0R
OEM PART NO	DESCRIPTION	ET.LBM0C.003
791411301601R	PCBA,I/F BOARD(V2,EMEA,W/SPK)LE22D2-612	1
791411301602R	PCBA,I/F BOARD(V2,W/SPK),LE22D2-612 ROHS	0
791411401610R	PCBA,P/I BOARD,W/SPK,LE22D2-612 ROHS	1
791401500000R	PCBA,KEYPAD BOARD,LE9D0-612 ROHS	1
453070801190R	PWRCORD 16A/250V BLK 6FT VDE/KTL H05VV-F	1
453070800230R	PWRCORD 5A/250V BLK 6FT UK3Gx.75mm(SP60/	1
453030300370R	CABLE,DVI-D 18+1P MALE 6FT BLACK , ROHS	1
453010100380R	CABLE,D-SUB 15P MALE 6FT BLACK/BLUE, ROH	1
453030300120R	CABLE AUDIO 1P 6FT BLACK/GREEN CP03B06P0	1
430300801700R	HRN ASSY 2x4P 100mm UL1571#28,ROHS	1
430300801690R	HRN ASSY 2x4P to 8P 245mm UL1571#28,ROHS	1
430303001510R	HRN LVDS FFC 30P 228mm W/TASTE ROHS	1
714011202700R	ASSY,STAND,B223W/LE22D2	1
714030015520R	ASSY,BEZEL,FRONT,(black),B223W/LE22D2	1
714050014231R	ASSY,COVER,BACK,W/DVI,W/SPK,AUO,B223W/LE	1
502090310311R	CHASSIS,W/DVI,W/SPK,B223W/LE22D2	1
618100200350R	SPEAKER 2W 8 340mm & 370mm R/G/B W/CASE	1
631102220180RA	LCP 22" M220EW01-V0-000(A)(AUO)ROHS	1
631102220190RA	LCP 22" M220EW01-V0-00A(A)(AUO)ROHS	1
631102220220RA	LCP 22" M220EW01-V0B(AUO)ROHS	1

06 Schematics and Layouts

6.1 PI BD Layout

491961400100R

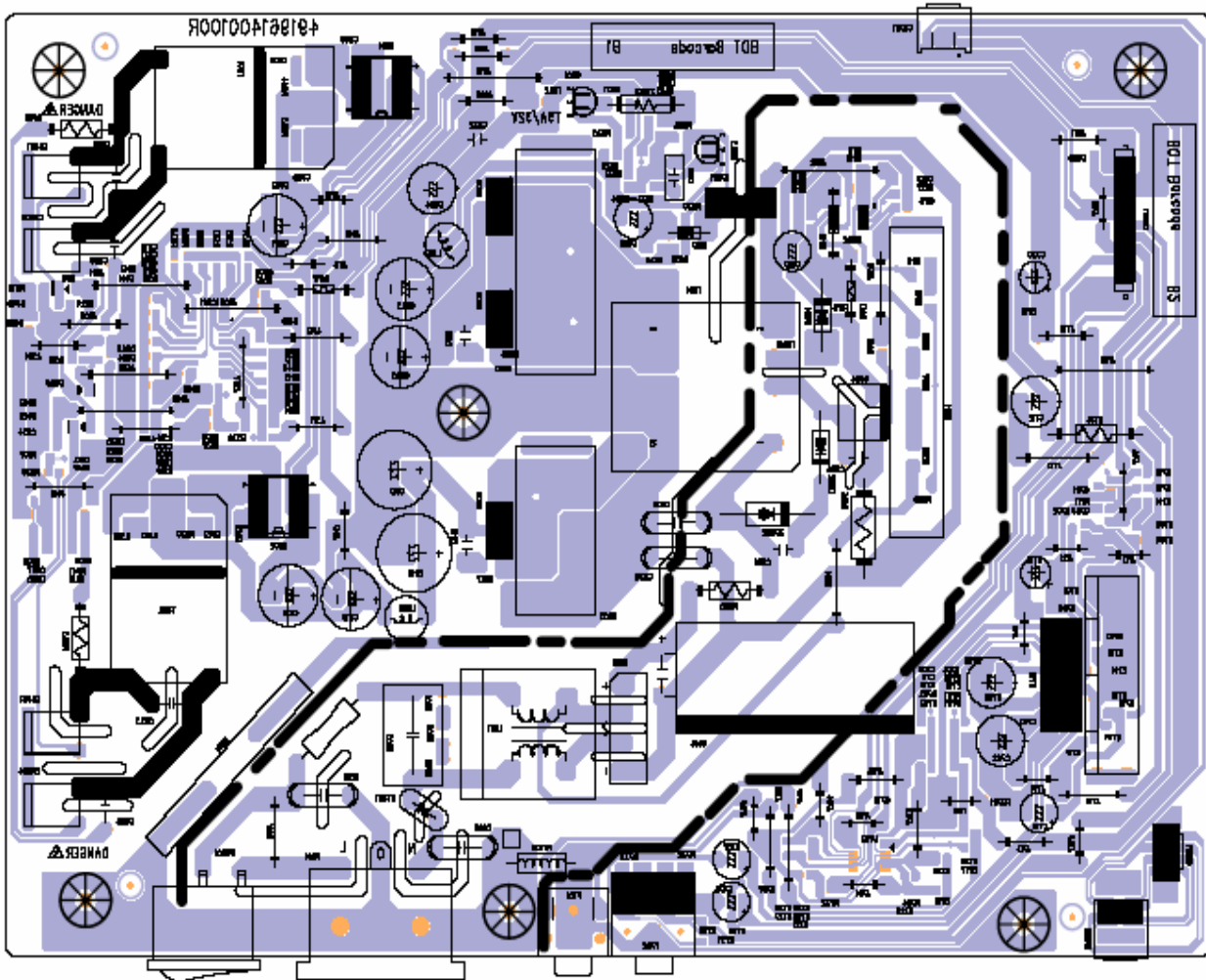

LAYER		SILKSCREEN BOTTOM			
Innolux	PCB NO	491961400100R	REV	A	DESIGNER: ChenSX
	FILE NO	ILPI-075 Rev.A	REMARK	2008/07/08	

491961400100R

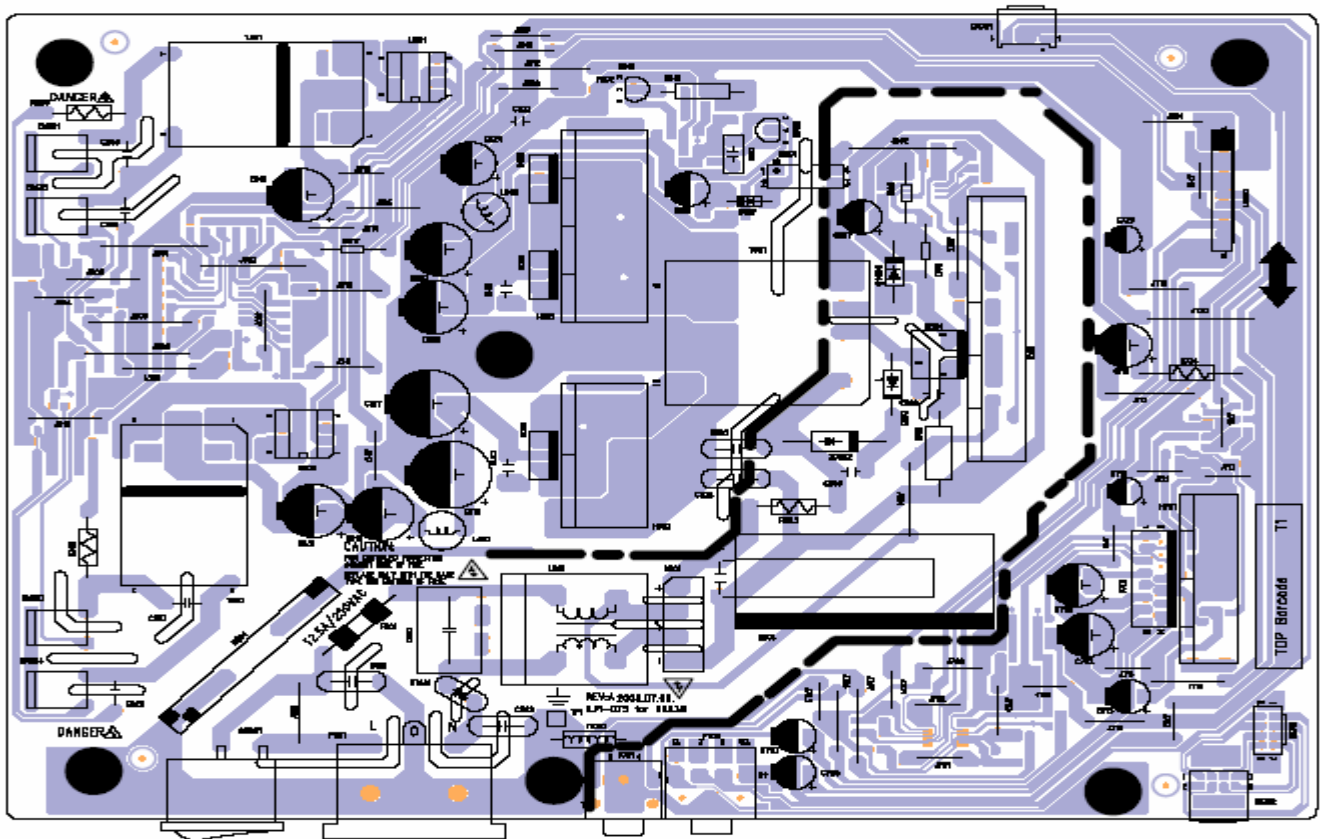

	LAYER	SILKSCREEN TOP			
Innolux	PCB NO	491961400100R	REV	A	DESIGNER: ChenSX
	FILE NO	ILPI-075 Rev.A	REMARK	2008/07/08	

6.2 IF BD Layout

LAYER	SILKSCREEN TOP				
PCB NO :	ILIF-032	REV :	A	DESIGNER:	Evo
FILE NAME :	ILIF-032.PCB	DATE :	2006.12.26		

490901300100R

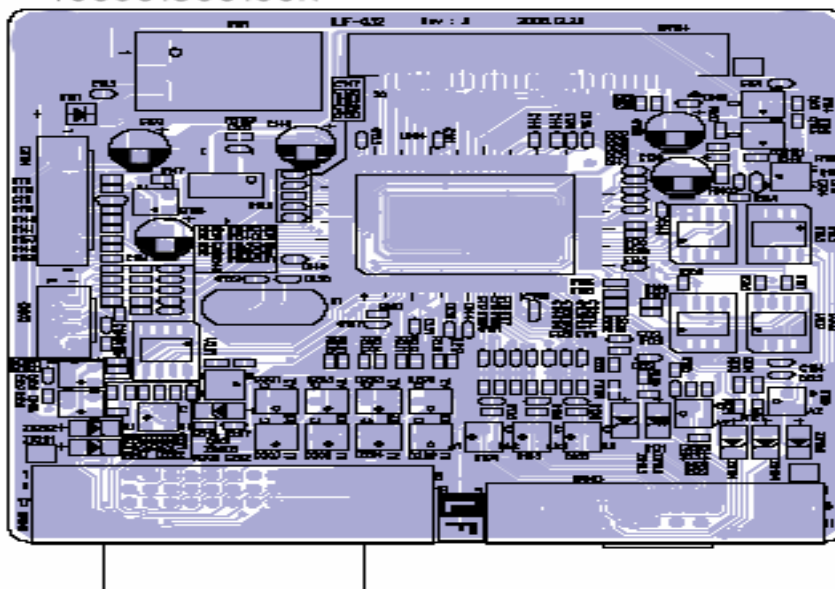

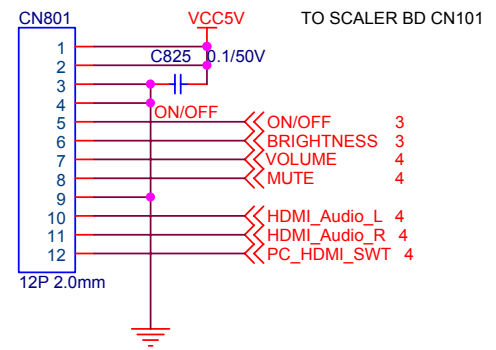
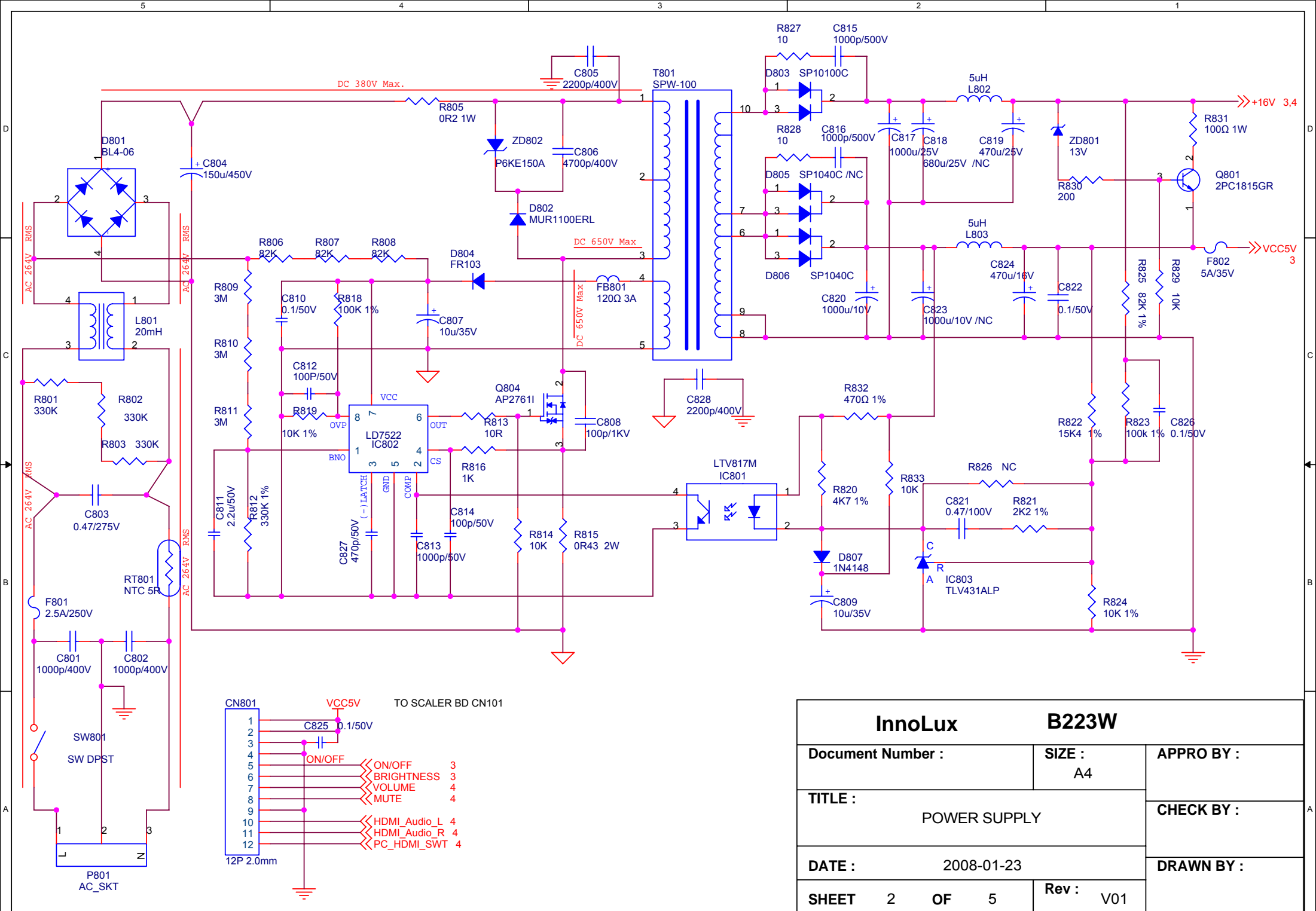

InnoLux		B223W	
Document Number :		SIZE : A4	APPRO BY :
TITLE : POWER SUPPLY		CHECK BY :	
DATE : 2008-01-23		DRAWN BY :	
SHEET 2	OF 5	Rev : V01	

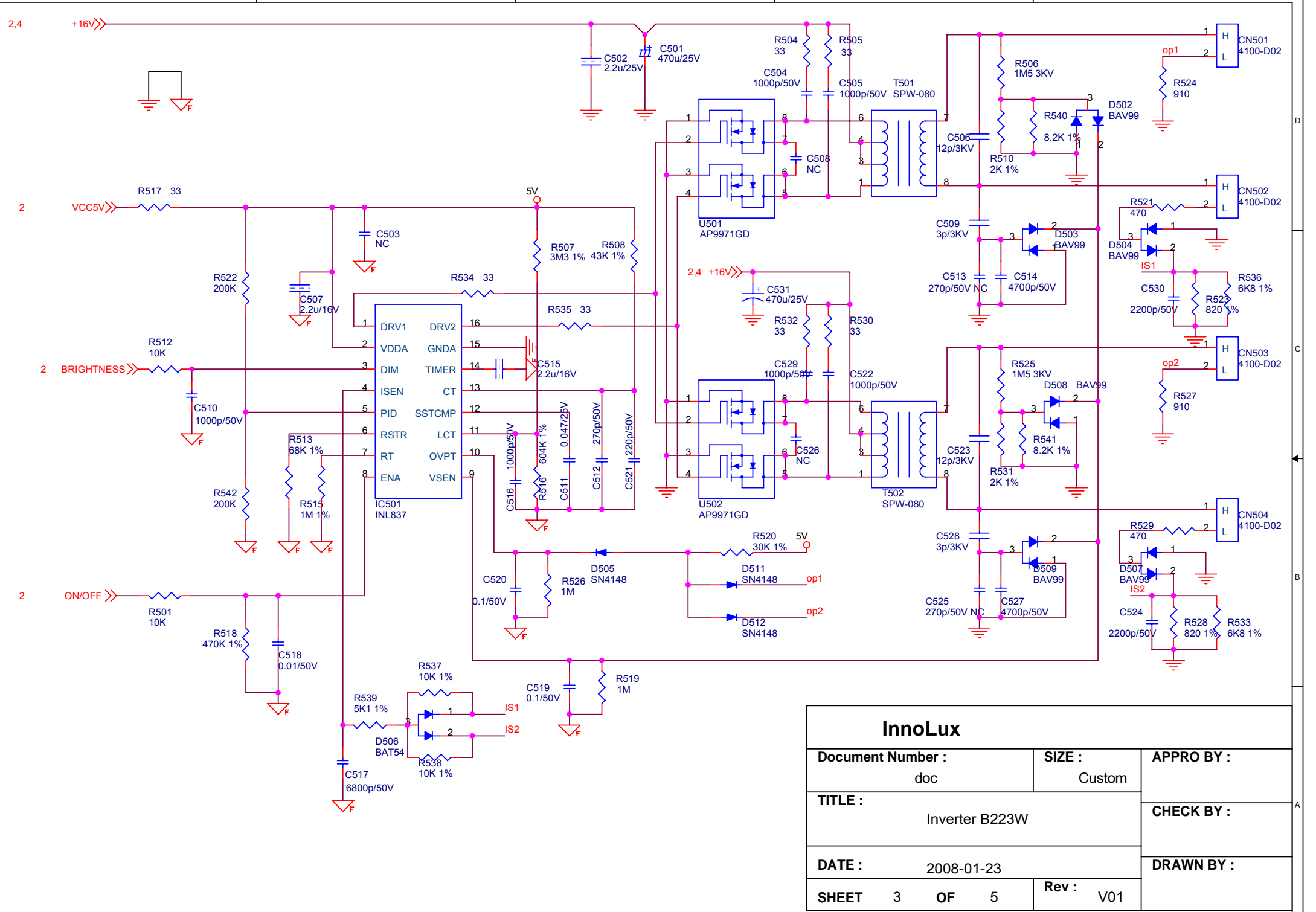

InnoLux			
Document Number : doc		SIZE : Custom	APPRO BY :
TITLE : Inverter B223W			CHECK BY :
DATE : 2008-01-23		DRAWN BY :	
SHEET	3 OF 5	Rev :	V01

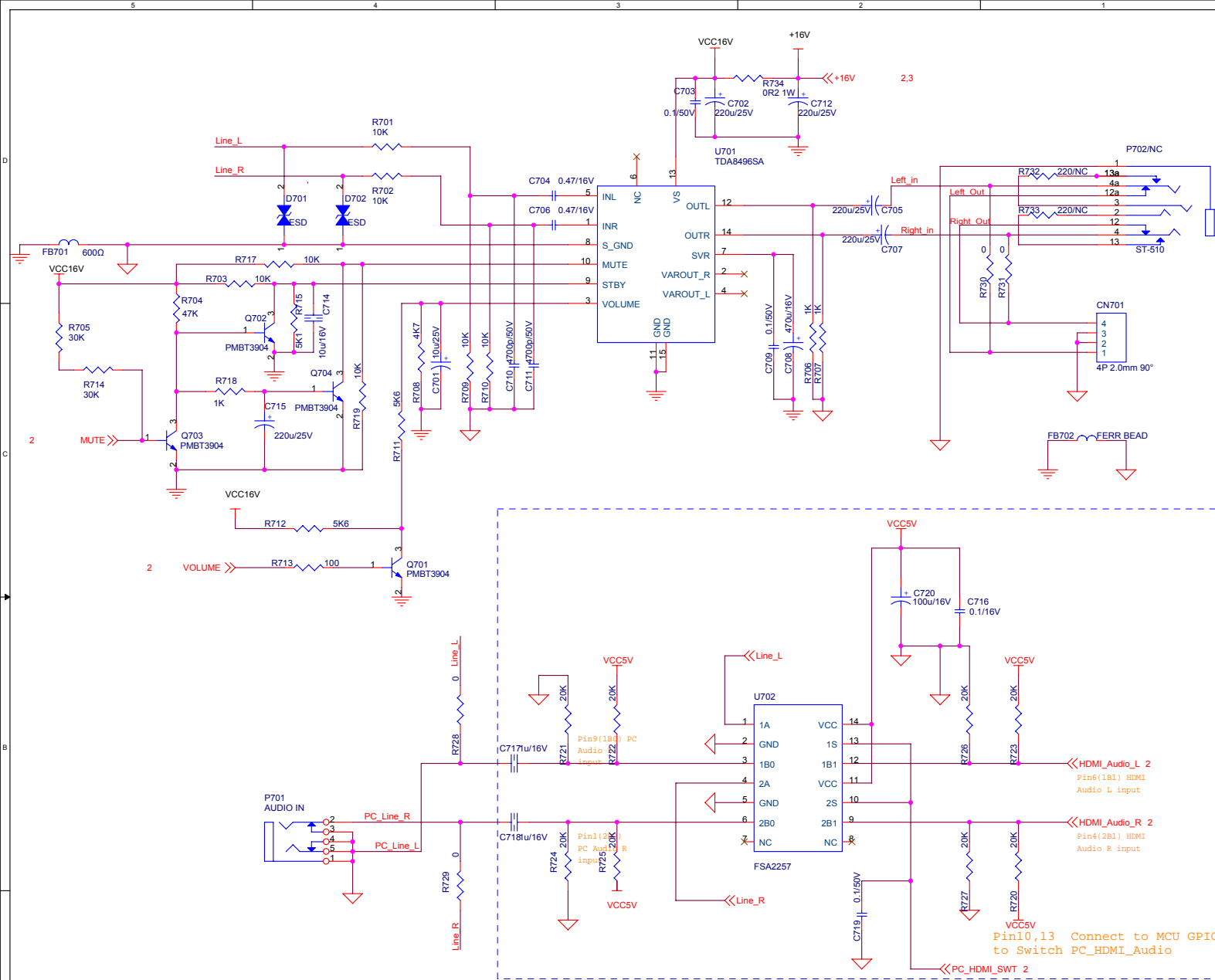

InnoLux		
Document Number :	SIZE :	APPRO BY :
doc	Custom	
TITLE :		CHECK BY :
Audio_BV223W		
DATE :		DRAWN BY :
2007-12-12		
SHEET 4 OF 5	Rev : V01	

Pin Define

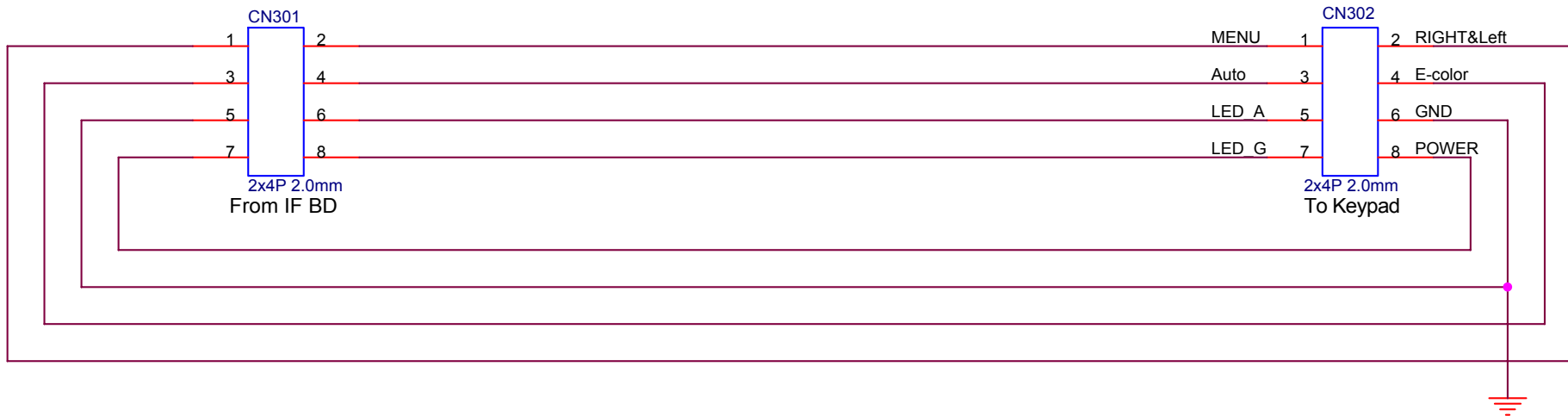

IF CN102	CON CN301	CON CN302	KEYPD CON
2x4p 2.0mm 180degree	2x4p 2.0mm 180degree	2x4p 2.0mm 90degree	1x8p 1.25mm180degree
1	2	1	8
2	1	2	7
3	4	3	6
4	3	4	5
5	6	5	4
6	5	6	3
7	8	7	2
8	7	8	1





InnoLux

Document Number : doc	SIZE : A	APPRO BY :
TITLE : Connector_ BV223W		CHECK BY :
DATE : 2007-12-12		DRAWN BY :
SHEET 5 OF 5	Rev : V01	



7.0 Assembly and Disassembly

Sequence	Item	Photo	Procedures	P/N	Description
S1	Place panel		<p>(1).Take panel out of box and place it on the foam.</p> <p>(2).Tear open the PE bag and put it in the designated carton.</p> <p>(3).Place panel on the foam like the attached picture.</p> <p>Remark:Do not touch the lamp cord and place the surface of panel downsides on the cushion.</p>	631102220091R	LCP 22"MT220WW0 1-V0- G1,AM2200001 001(INNO
S2	Insert Keypay's wrie		<p>1.Check if the keypad and relevent wire you choose are OK.</p> <p>2.Insert the wire into the keypad like the Picture</p>	430300801690R	HRN ASSY 2x4P to 8P 245mm UL1571#28,RO HS
S3	Fix front bezel		<p>1.Check if there is any lacquer missed or sctrach happened to the front bezel.</p> <p>2.Insert the fixed keypad into the front bezel as picture</p>	714030015400R	ASSY,BEZEL,F RONT,(silver),LE 22D3



Assembly and Disassembly (continue)

S4	Assemble front bezel		<p>1.Reverse the panel by 180 degree,put the surface of panel upsides and insert front bezel in the panel.</p> <p>2.Reverse the panel by 180 degree using both hands,put the surface of panel downsides and make sure FFC interface is closer to operator.</p> <p>3.Paste tinfoil on the position which refers to attached picture,in order to cover the gap in the panel completely.</p> <p>Remark:Make sure the fixed job is finished properly and lamp wire is closer to right hand;Make the tinfoil smooth in the corner of panel.</p>	714030015400R	ASSY,BEZEL,FRONT,(silver),LE22D3
S5	Fix mainboard		<p>(1).Insert FFC wire into its relevant interface of mainboard properly like attached picture1.</p> <p>(2).Insert the short keypad into its relevant interface like picture1.</p> <p>(2).Put the fixed mainboard in the right position.</p>	791411300600R	PCBA,I/F BOARD(V0,EMEA,W/O),LE22D3-612 R
S6	Fix chassis & power board		Place the chassis on the cushion after check,like the attached Picture1.	701000007010R	ASSY,CHASSIS,W/DVI,LE22D3

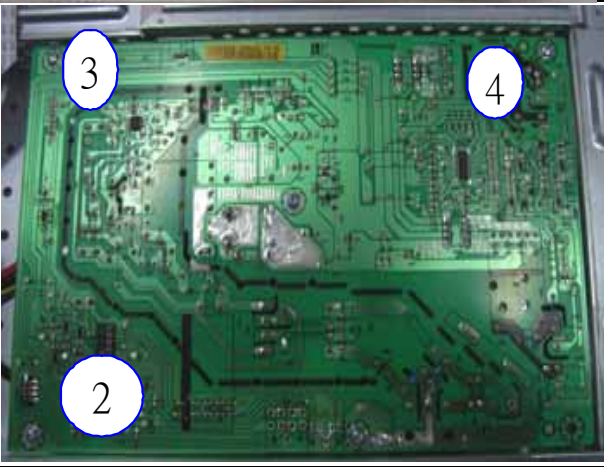

Assembly and Disassembly (continue)

S7	Fix chassis & power board		Insert powerboard into the designated location of chassis ,like the attached Picture	791411401600R	PCBA,P/I BOARD,W/O SPK,LE22D2-612 ROHS
S8	Connect mainboard & power board		Connect powerboard with the relevant PIN in the mainboard like the attached Picture		
S9	Twist PCBA screw		Handle electric opener and one pcs of M3*6 screw	509146306200R	SCREW,P,CROSS,W/WAS,M3*6,Zn-Cc

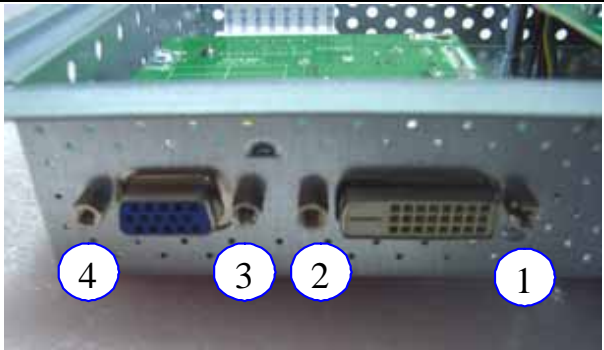
Assembly and Disassembly (continue)

<p>S10</p>	<p>Twist PCBA screw</p>		<p>Fix 3 pcs of screws separately on the poweboard and mainboard like the attached Picture1</p>	<p>509146306200R</p>	<p>SCREW,P,CROSS, W/WAS, M3*6, Zn-Cc</p>
<p>S11</p>	<p>Twist screw for ground- wire</p>		<p>Paste FFC wire on the disignated location like the attached Picture</p>		
<p>S12</p>	<p>Twist Hexagonal screws</p>		<p>(1). Handle hexagonal screws and electric opener (2). Twist screw in the interface like the attached Picture1. (3). Place cushion on the designated location after iron frame is taken away.</p>		

Assembly and Disassembly (continue)

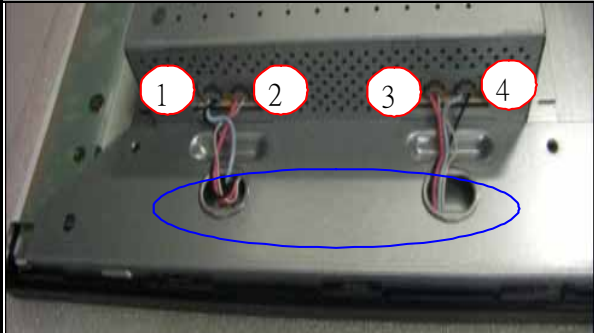
S13	Fix chassis		Thread lamp wire into the relevant hole of chassis like the attached Picture		
S14	Fix chassis		<ol style="list-style-type: none"> 1)Fix chassis on the back of panel and front bezel 2)Put lamp wire and FFC wire in order as picture 		
S15	Insert FFC cable		<ol style="list-style-type: none"> 1. Tear off the adhesive tape of FFC wire; 2. Insert FFC wire into the interface of panel 3. Put FFC wire in order and paste them on the panel 4. Fix chassis on the back of panel 		
S16	Insert light wire		<ol style="list-style-type: none"> 1) Insert 4pcs light wire into the relevant position 2) put the balance light wire to the position as picture 		

Assembly and Disassembly (continue)

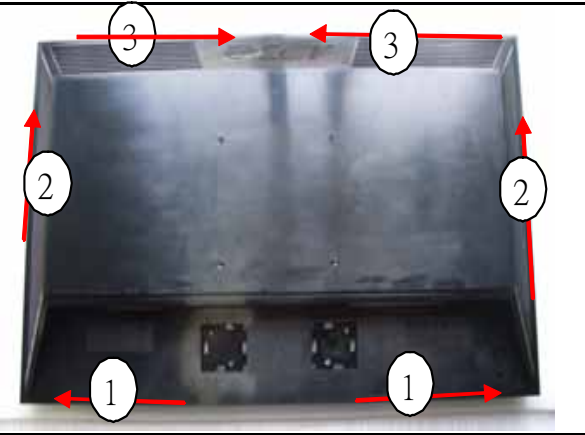
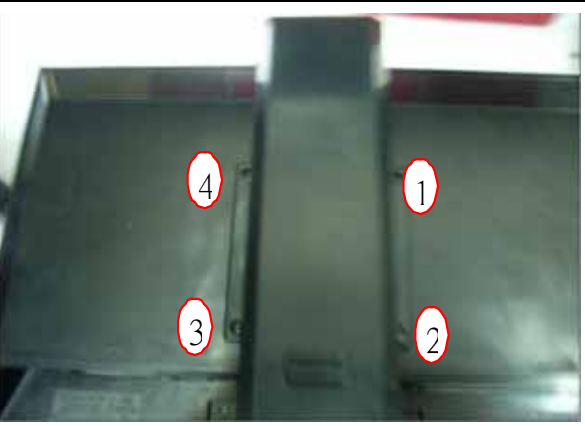
<p>S17</p>	<p>Insert keypad Cable</p>		<p>1)Insert keypad wire into the relevant PIN in the keypad (2)Fix button on the relevant position of assemble (3)Confirm if keypad is inserted properly and make sure the red cable in left</p>		
<p>S18</p>	<p>Fix back cover</p>		<p>Check if back cover is fixed properly</p>		
<p>S19</p>	<p>Fix stand</p>		<p>Use 4pcs screw fix stand on the back of assemble like attached Picture</p>		

Free Manuals Download Website

<http://myh66.com>

<http://usermanuals.us>

<http://www.somanuals.com>

<http://www.4manuals.cc>

<http://www.manual-lib.com>

<http://www.404manual.com>

<http://www.luxmanual.com>

<http://aubethermostatmanual.com>

Golf course search by state

<http://golfingnear.com>

Email search by domain

<http://emailbydomain.com>

Auto manuals search

<http://auto.somanuals.com>

TV manuals search

<http://tv.somanuals.com>