

SERVICE MANUAL



P3150/P3250/P3150 Refresh/P3250 Refresh/P3251

| Date | Revise Version | Description |
|------------|----------------|---|
| 2008.4.10 | V1.0 | Initial Issue |
| 2008.5.28 | V2.0 | Add Marketing Spec in Chapter 1 |
| 2008.7.22 | V3.0 | Add P3150 Refresh/P3250 Refresh |
| 2008.10.10 | V4.0 | Add Waveform Download in Ch5 modify Ch4, Ch6 and AppendixB |
| 2010.02.26 | V5.0 | Add P3251 |

Copyright Feb.2010 All Rights Reserved P/N: 36.89K01G001

Prepared: *huhui*

Checked: *Joanna*

Approved: *Aliek*

Comparison List

| PART | P3251 | P3150 | P3150 refresh | P3250 | P3250 refresh |
|-----------------|--------------|--------------|---------------|--------------|---------------|
| FAN | 49.8FN01G001 | 49.89S01G001 | | | |
| ENGINE | 70.8GC07GR01 | 70.89Y22GR01 | | | |
| PHOTO SENSOR BD | 80.8GB04G001 | 80.88N04G001 | | | |
| COLOR WHEEL | 70.8GC08GR01 | 70.89Y21GR01 | | | |
| DMD BD | 80.8FN02G001 | 80.89S02G001 | | | |
| DMD CHIP | 48.8CQ01G003 | 48.87K01G001 | | 48.87M01G001 | |
| BALLAST | 70.8GC09GR01 | 70.89Y27GR01 | | | |
| SPEAKER | 49.8GC01G001 | 49.89Y01G001 | | | |
| MAIN BD | 70.8GC10GR01 | 70.89Y23GR01 | 70.89Y33GR01 | 70.89Y29GR01 | 70.89Y33GR01 |
| DAUGHTER BD | 80.8GB06G001 | NA | | | |
| FRONT COVER | 70.8GC11GR01 | 70.89Y24GR01 | | | |
| FFC CABLE | 42.00300G001 | 42.89501G002 | | | |
| KEYPAD BD | 80.8GB03G001 | 80.89Y03G001 | | | |
| TOP COVER | 70.8GC12GR01 | 70.89Y25GR01 | | 70.89Y30GR01 | |
| BOTTOM COVER | 70.8GC13GR01 | 70.89Y26GR01 | | | |
| IR SENSOR BD | 80.8GB05G001 | 80.89S05G001 | | | |

Preface

This manual is applied to P3150/P3250/P3150 refresh/P3250 refresh/P3251 projection system. The manual gives you a brief description of basic technical information to help in service and maintain the product.

Your customers will appreciate the quick response time when you immediately identify problems that occur with our products. We expect your customers will appreciate the service that you offer them.

This manual is for technicians and people who have an electronic background. Please send the product back to the distributor for repairing and do not attempt to do anything that is complex or is not mentioned in the troubleshooting.

Notice:

The information found in this manual is subject to change without prior notice. Any subsequent changes made to the data herein will be incorporated in future edition.

P3150/P3250/P3150 refresh/P3250 refresh/P3251 Service Manual

Copyright Feb.2010

All Rights Reserved

Manual Version 5.0

Table of Content

Chapter 1 Introduction

| | |
|------------------|-----|
| Highlight | 1-1 |
| Compatible Mode | 1-4 |
| Product Overview | 1-6 |

Chapter 2 Disassembly Process

| | |
|---|------|
| Equipment Needed & Product Overview | 2-1 |
| Disassemble Lamp Cover Module | 2-2 |
| Disassemble Lamp Module | 2-3 |
| Disassemble Top Cover Module | 2-4 |
| Disassemble Key Pad Board Module | 2-5 |
| Disassemble Zoom Ring Module | 2-5 |
| Disassemble Main Board Module | 2-6 |
| Disassemble Color Wheel Module | 2-8 |
| Disassemble Front Cover Module | 2-9 |
| Disassemble Ballast Module | 2-10 |
| Disassemble DC-DC Module | 2-11 |
| Disassemble Thermal Switch Module | 2-12 |
| Disassemble Lamp Blower and System Fan Module | 2-13 |
| Disassemble Lamp to Ballast Cable | 2-14 |
| Disassemble Engine Module | 2-15 |
| Disassemble DMD Board and DMD Ship | 2-15 |
| Disassemble Speaker Module | 2-16 |
| Disassemble Interrupt Switch Module | 2-16 |
| Disassemble IR Sensor Module | 2-17 |
| Rod Adjustment | 2-18 |

| | |
|--|------|
| Re-write Lamp Usage Hour | 2-19 |
| Assemble IR Sensor Module | 2-20 |
| Assemble Interrupt Switch Module | 2-20 |
| Assemble Speaker Module | 2-21 |
| Assemble DMD Board and DMD Chip Module | 2-22 |
| Assemble Engine Module | 2-22 |
| Assemble Lamp to Ballast Module | 2-23 |
| Assemble Lamp Blower and System Fan Module | 2-24 |
| Assemble Thermal Switch Module | 2-25 |
| Assemble DC-DC Module | 2-26 |
| Assemble Ballastl Module | 2-27 |
| Assemble Front Cover Module | 2-28 |
| Assemble Color Wheel Module | 2-29 |
| Assemble Main Board Module | 2-30 |
| Assemble Zoom Ring Module | 2-31 |
| Assemble Key Pad Board Module | 2-32 |
| Assemble Top Cover Module | 2-33 |
| Assemble Lamp Module | 2-34 |
| Assemble Lamp Cover Module | 2-35 |

Chapter 3 Troubleshooting

| | |
|----------------------|-----|
| LED Lighting Message | 3-1 |
| Main Procedure | 3-3 |
| Beep Sound | 3-4 |

Chapter 4 Function Test & Alignment Procedure

| | |
|-----------------------|-----|
| Test Equipment Needed | 4-1 |
| Service Mode | 4-1 |

| | |
|------------------------------------|------|
| OSD Reset | 4-1 |
| Test Condition | 4-2 |
| Test Inspection Procedure | 4-4 |
| PC Mode | 4-4 |
| Video Performance | 4-7 |
| Optical Performance Measure | 4-9 |
| SD Card /USB Test (only for P3251) | 4-11 |
| Other | 4-12 |

Chapter 5 Firmware Upgrade

| | |
|--|------|
| Section 1: System Firmware Upgrade | 5-1 |
| Equipment Needed | 5-1 |
| DLP Composer Lite Setup Procedure | 5-2 |
| USB Driver Upgrade Procedure | 5-4 |
| Firmware Upgrade Procedure | 5-5 |
| Section 2 : Waveform Download | 5-9 |
| Waveform Download (for refresh models) | 5-9 |
| Waveform Download (for P3251) | 5-10 |
| Section 3 : Multi-Media Firmware Upgrade(only for P3251) | 5-11 |
| Equipment Needed | 5-11 |
| USB Driver Upgrade Procedure | 5-12 |
| Multi-Media Firmware Upgrade Procedure | 5-14 |

| | | |
|-------------------|---------------------------------|-----|
| Chapter 6 | EDID Upgrade | |
| | EDID Introduction | 6-1 |
| | Equipment Needed | 6-2 |
| | Setup Procedure | 6-3 |
| | EDID Key-In Procedure | 6-3 |
| | Setup Procedure (HDMI) | 6-7 |
| | Default Language Reset | 6-9 |
| | | |
| Appendix A | P3150/P3250 Exploded Overview | I |
| | | |
| Appendix B | Serial Number System Definition | I |
| | PCBA Code Definition | II |

Introduction

1-1 Highlight

| No | Item | Description |
|----|-----------------------|--|
| 1 | Dimensions (WxDxH) | - 209 x 74.2 x 172.2 mm (for P3150/P3250/P3150 Refresh/ P3250 Refresh) - 209 x 64 x 164mm (for P3251) |
| 2 | Weight | - 1.24 kg |
| 3 | Tilt Angle | - 7 degree with elevator mechanism |
| 4 | Keystone correction | - +/- 40 degree (80 degree) |
| 5 | DMD Chip | - TI DMD 0.55" 12° 2xLVDS Type-X SVGA Digital Mirror Device (for P3150/P3150 refresh) - TI DMD 0.55" 12° 2xLVDS Type-X XGA Digital Mirror Device (for P3250/P3250 refresh) - TI DMD 0.55" 12° 2xLVDS S450 XGA Digital Mirror Device (for P3251) |
| 6 | Number of active dots | - 800(H) x 600(V) (for P3150/P3150 refresh) - 1024(H) x 768(V) (for P3250/3250 refresh/P3251) |
| 7 | Power Supply | - Universal AC 100 -240 V ~ 50-60 Hz with PFC input - Variance FAN speed control (Depends on temperature variant) |
| 8 | Terminal | For all models: - HDMI * 1: One HDMI connector for HDMI-Video/audio and HDMI-Graphic Signal. (HDMI v1.3 for P3251, HDMI v1.1 for P3250/P3150) - VGA input (D-SUB X 1) - Video input (RCA jack Type X 1, Mini DIN 4-pin S-video X 1) - Audio input (Phone jack Type X 1) - USB (Type-B X 1) Only for P3251: - SD * 1 - USB (Type-A* 1) |
| 9 | Lamp | - 165 Watt for OSRAM E17.6 Lamp @ normal operation |
| 10 | Projection lens | - F# 2.41 ~2.55, f = 21.79~23.99 mm, 1.10X Mechanical Zoom Lens |
| 11 | Projection Image Size | - Adjustable from 22.9" to 302.8" (Diagonal) (for P3150/P3250/ P3150 Refresh/P3250 Refresh) - Adjustable from 27.5" to 303" (for P3251) |

| No | Item | Description |
|----|---------------------|--|
| 12 | Throw Distance | - 1.0m – 12m |
| 13 | Throw Ratio | - 1.95 – 2.15:1 @ 60” |
| 14 | Input signal spec | <p>- Video Signal RGB (PC)</p> <ul style="list-style-type: none"> • Analog RGB 0.7Vp-p, 75 ohm, Separate TTL H,V Sync • Analog RGB 1Vp-p, 75 ohm, Sync. On Green signal • Analog RGB 0.7Vp-p, 75 ohm, Composite TTL Sync. <p>- Video</p> <ul style="list-style-type: none"> • Composite video 1Vp-p,75 ohm • S-video Luminance 0.714Vp-p, 75 ohm • Chrominance 0.286Vp-p, 75 ohm • Component Video 1Vp-p, 75 ohm <p>For P3150/P3250/P3150 Refresh/P3250 Refresh:</p> <ul style="list-style-type: none"> - Hsync Frequency 31.5 k ~ 100 kHz - Vsync Frequency 50 ~ 85 Hz <p>For P3251:</p> <ul style="list-style-type: none"> - Hsync Frequency 30 ~ 100 kHz - Vsync Frequency 50 ~ 120 Hz |
| 15 | Video Compatibility | <p>- Standards :</p> <ul style="list-style-type: none"> • NTSC (3.58/4.43) • PAL (B/D/G/H/I/M/N) • SECAM (B/D/G/K/K1/L) • HDTV - 480p, 576p, 720p, 1080i (for P3150/3150 refresh) • HDTV - 480p, 576p, 720p, 1080p (for P3250/P3250 refresh) • HDTV (480i,576i 480p, 576p, 720p, 1080i, 1080p) (for P3251) |
| 16 | Brightness | <p>P3150/P3250/P3150 refresh/P3250 refresh</p> <p>- Engineering Spec:</p> <ul style="list-style-type: none"> • 1800 ANSI Lumens (Typical; Full power mode) • 1600 ANSI Lumens (Minimum; Full power mode) <p>- Marketing Spec:</p> <ul style="list-style-type: none"> • 2000 ANSI Lumens <p>P3251 Engineering Spec:</p> <p>- Engineering Spec:</p> <ul style="list-style-type: none"> • 1890 ANSI Lumens (Typical) • 1680 ANSI Lumens (Minimum) <p>- Marketing Spec:</p> <ul style="list-style-type: none"> • 2100 ANSI Lumens |

| No | Item | Description |
|----|-----------------------|---|
| 17 | Contrast | P3150/P3250/P3150 refresh/P3250 refresh : - Engineering Spec: <ul style="list-style-type: none"> ● 1400 : 1 Full White and Black (Minimum; Full power mode) ● 1800 : 1 Full White and Black (Typical; Full power mode) - Marketing Spec: <ul style="list-style-type: none"> ● 2000 :1 Full White and Black P3251 : - Engineering Spec: <ul style="list-style-type: none"> ● 2100 : 1 Full White and Black (Minimum; Full power mode) ● 3300 : 1 Full White and Black (Typical; Full power mode) - Marketing Spec: <ul style="list-style-type: none"> ● 3700 :1 Full White and Black |
| 18 | Uniformity | Engineering Spec: - 65% Japan standard (Minimum; Full power mode) - 80% Japan standard (Typical; Full power mode) Marketing Spec: - 85% Japan standard |
| 19 | Color Wheel | <ul style="list-style-type: none"> ● 6 segments (R90Y28G90C28W42B80) (for P3150/P3250/P3150 refresh/P3250 refresh) ● 6 segments (R81Y41G84C31W52B71) (for P3251) - 7200rpm @ 2x - 9000rpm @ 3x, PAL 50Hz |
| 20 | Operation temperature | - 5°C -- 35°C |
| 21 | Storage temperature | - -20°C -- 60°C |
| 22 | Maximum Humidity | - Operating: 5°C -- 35°C, 80%RH (Max.), non-condensing - Storage: -20°C -- 60°C, 80%RH (Max.), non-condensing |
| 23 | Lamp life | P3150/P3250/P3150 refresh/P3250 refresh : - 3000 hours min, 50% survival rate (Full power Mode) - 4000 hours min, 50% survival rate (Eco power Mode) P3251 : - 3500 hours, 50% survival rate (Full power Mode) - 5000 hours, 50% survival rate (Eco power Mode) |
| 24 | System controller | - TI DDP2230 (for P3150/P3250/P3150 refresh/P3250 refresh) - TI DDP2431 (for P3251) |

1-2 Compatible Mode

A. Analog (for P3150/P3250/P3150 Refresh/P3250 Refresh)

| Compatibility | Resolution | V-Sync [Hz] | H-Sync [KHz] |
|---------------|------------|-------------|--------------|
| VGA | 640x480 | 60 | 31.50 |
| | 640x480 | 72 | 37.90 |
| | 640x480 | 75 | 37.50 |
| | 720x400 | 70 | 31.50 |
| SVGA | 800x600 | 56 | 35.20 |
| | 800x600 | 60 | 37.90 |
| | 800x600 | 72 | 48.10 |
| | 800x600 | 75 | 46.90 |
| | 832x624 | 75 | 49.73 |
| XGA | 1024x768 | 60 | 48.40 |
| | 1024x768 | 70 | 56.50 |
| | 1024x768 | 75 | 60.00 |
| SXGA | 1152x864 | 70 | 63.80 |
| | 1280X1024 | 60 | 63.98 |
| QuadVGA | 1280x960 | 60 | 59.70 |
| | 1280x960 | 75 | 75.23 |
| SXGA+ | 1400x1050 | 60 | 65.32 |
| WXGA | 1280x800 | 60 | 49.702 |
| | 1360x768 | 60 | 47.72 |
| | 1440x900 | 60 | 55.935 |
| | 1680x1050 | 60 | 65.290 |
| UXGA | 1600x1200 | 60 | 75.00 |
| Power Mac G4 | 640x480 | 66.6(67) | 34.93 |
| | 800x600 | 60 | 37.90 |
| | 1024x768 | 60 | 48.40 |
| | 1152x870 | 75 | 68.68 |
| | 1280x1024 | 60 | 63.98 |
| PowerBook G4 | 640x480 | 60 | 31.35 |
| | 640x480 | 66.6(67) | 34.93 |
| | 800x600 | 60 | 37.90 |
| | 1024x768 | 60 | 48.40 |
| | 1152x870 | 75 | 68.98 |
| | 1280x1024 | 60 | 63.98 |
| i Mac DV (G3) | 1024X768 | 75 | 60.00 |

B. Digital (for P3150/P3250/P3150 Refresh/P3250 Refresh)

| Compatibility | Resolution | V-Sync [Hz] | H-Sync [KHz] |
|---------------|------------|-------------|--------------|
| VGA | 640x480 | 60 | 31.50 |
| | 640x480 | 72 | 37.90 |
| | 640x480 | 75 | 37.50 |
| | 720x400 | 70 | 31.50 |
| SVGA | 800x600 | 56 | 35.20 |
| | 800x600 | 60 | 37.90 |
| | 800x600 | 72 | 48.10 |
| | 800x600 | 75 | 46.90 |
| | 832x624 | 75 | 49.73 |
| XGA | 1024x768 | 60 | 48.40 |
| | 1024x768 | 70 | 56.50 |
| | 1024x768 | 75 | 60.00 |
| SXGA | 1152x864 | 70 | 63.80 |
| | 1280X1024 | 60 | 63.98 |
| QuadVGA | 1280x960 | 60 | 59.70 |
| | 1280x960 | 75 | 75.23 |
| SXGA+ | 1400x1050 | 60 | 65.32 |
| WXGA | 1280x800 | 60 | 49.702 |
| | 1360x768 | 60 | 47.72 |
| | 1440x900 | 60 | 55.935 |
| | 1680x1050 | 60 | 65.290 |
| UXGA | 1600x1200 | 60 | 75.00 |
| Power Mac G4 | 640x480 | 66.6(67) | 34.93 |
| | 800x600 | 60 | 37.90 |
| | 1024x768 | 60 | 48.40 |
| | 1152x870 | 75 | 68.68 |
| | 1280x1024 | 60 | 63.98 |
| PowerBook G4 | 640x480 | 60 | 31.35 |
| | 640x480 | 66.6(67) | 34.93 |
| | 800x600 | 60 | 37.90 |
| | 1024x768 | 60 | 48.40 |
| | 1152x870 | 75 | 68.68 |
| | 1280x1024 | 60 | 63.98 |
| i Mac DV (G3) | 1024X768 | 75 | 60.00 |

1-3 Product Overview

Projector Outlook (P3150)

Front /Upper side

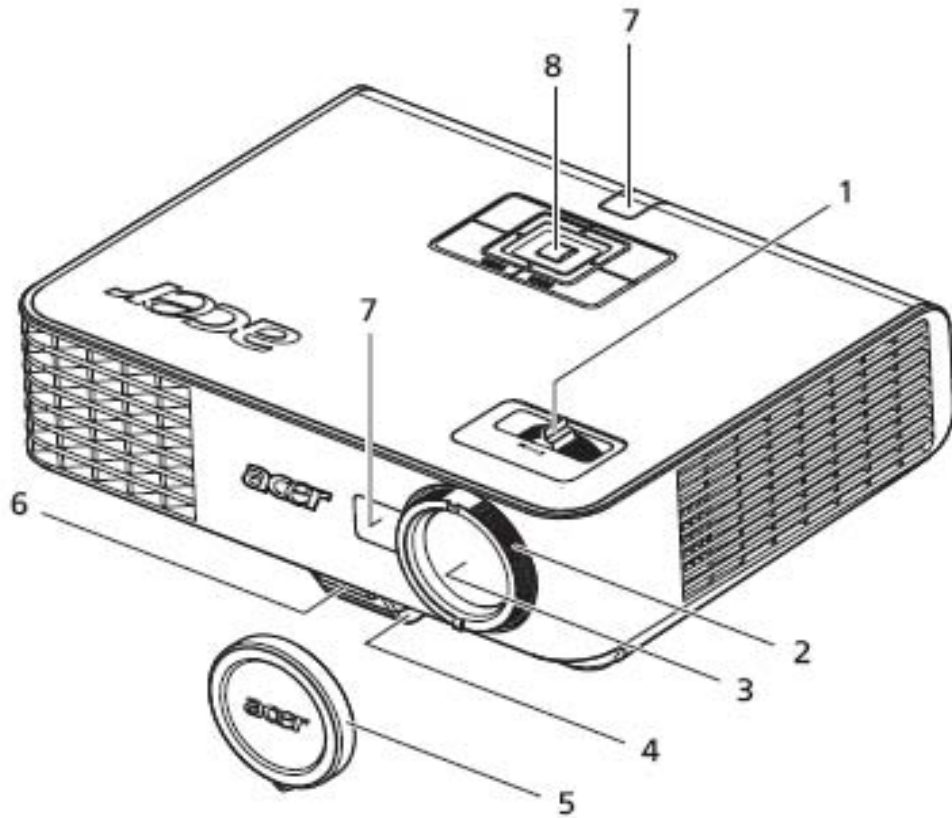

| Item | Description | Item | Description |
|------|---------------|------|--------------------------|
| 1 | Zoom Lever | 6 | Elevator button |
| 2 | Focus ring | 7 | Remote control receivers |
| 3 | Zoom lens | 8 | Control panel |
| 4 | Elevator foot | | |
| 5 | Lens cap | | |

Rear side (for P3150/P3250/P3150 Refresh/P3250 Refresh)

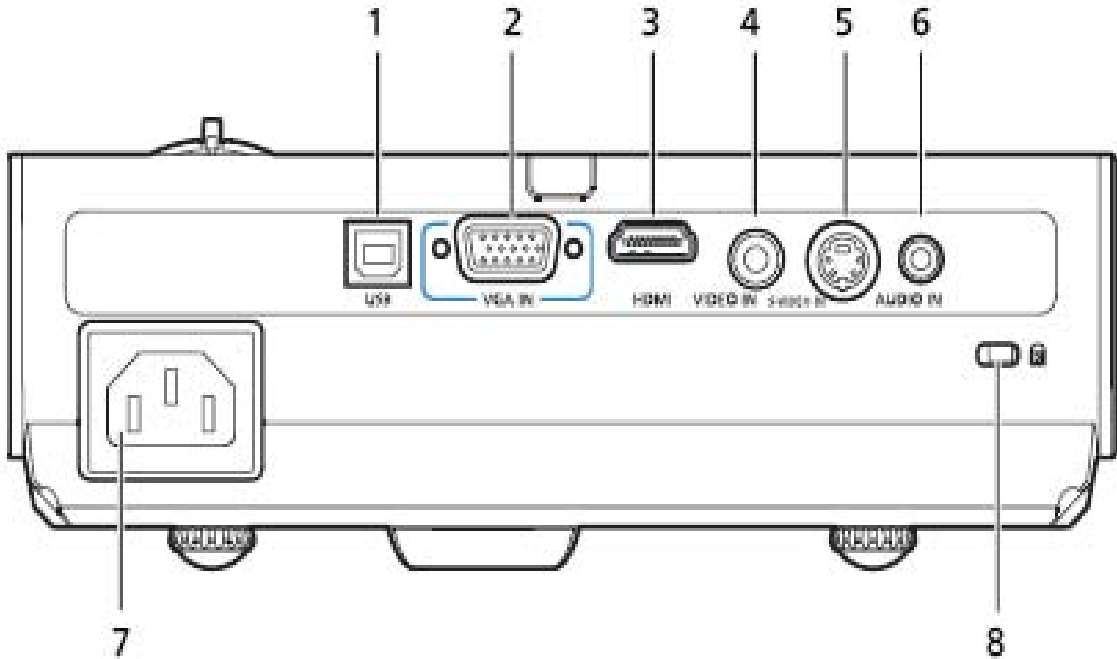

| Item | Description | Item | Description |
|------|---|------|-------------------------|
| 1 | USB connector | 5 | S-Video input connector |
| 2 | PC analog signal/HDTV/component video input connector | 6 | Audio input connector |
| 3 | HDMI connector | 7 | Power socket |
| 4 | Composite video input connector | 8 | KensingtonTM lock port |



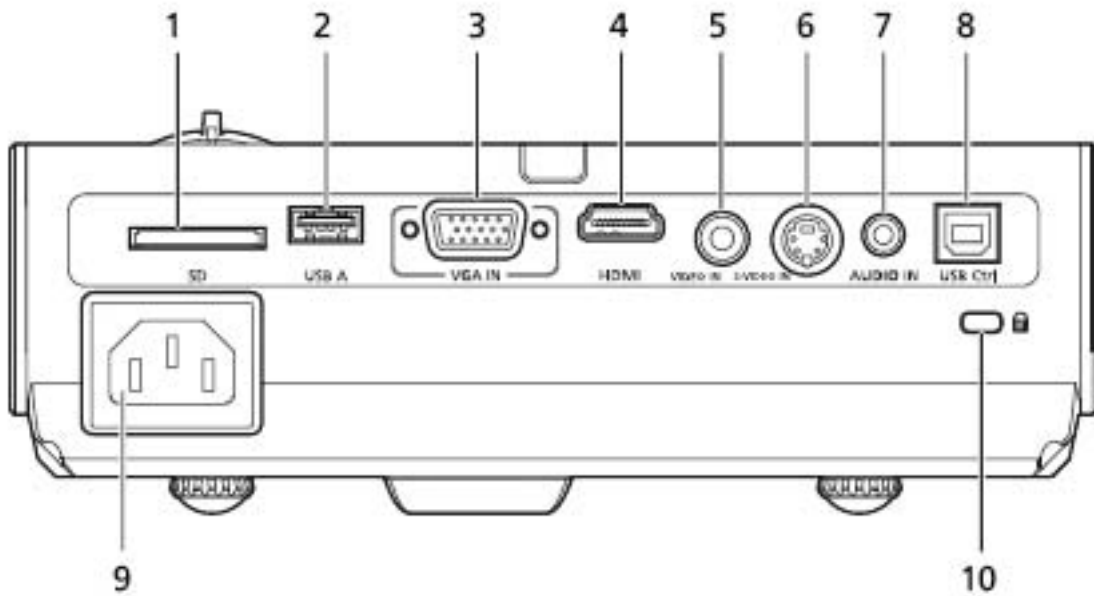

Rear side (for P3251)

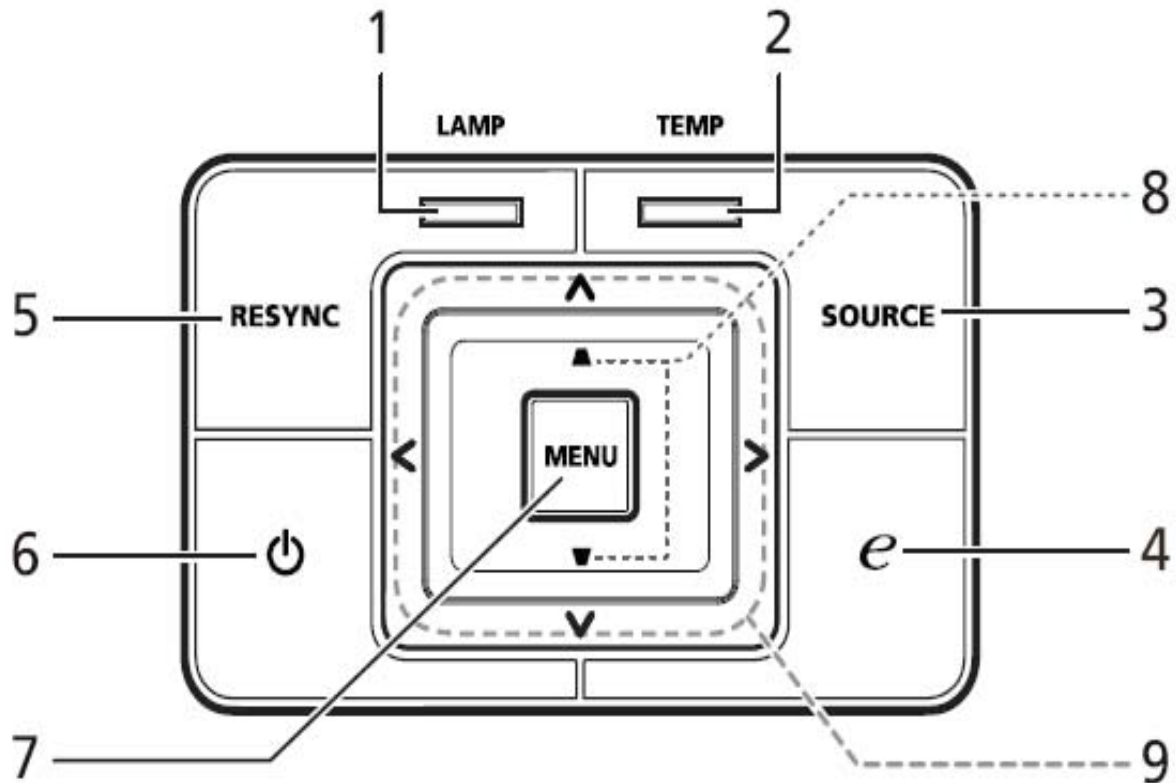

| Item | Description | Item | Description |
|------|---|------|-------------------------|
| 1 | SD Card reader | 6 | S-Video input connector |
| 2 | USB A connector | 7 | Audio input connector |
| 3 | PC analog signal/HDTV/component video input connector | 8 | USB control connector |
| 4 | HDMI connector | 9 | Power socket |
| 5 | Composite video input connector | 10 | KensingtonTM lock port |





Control Panel

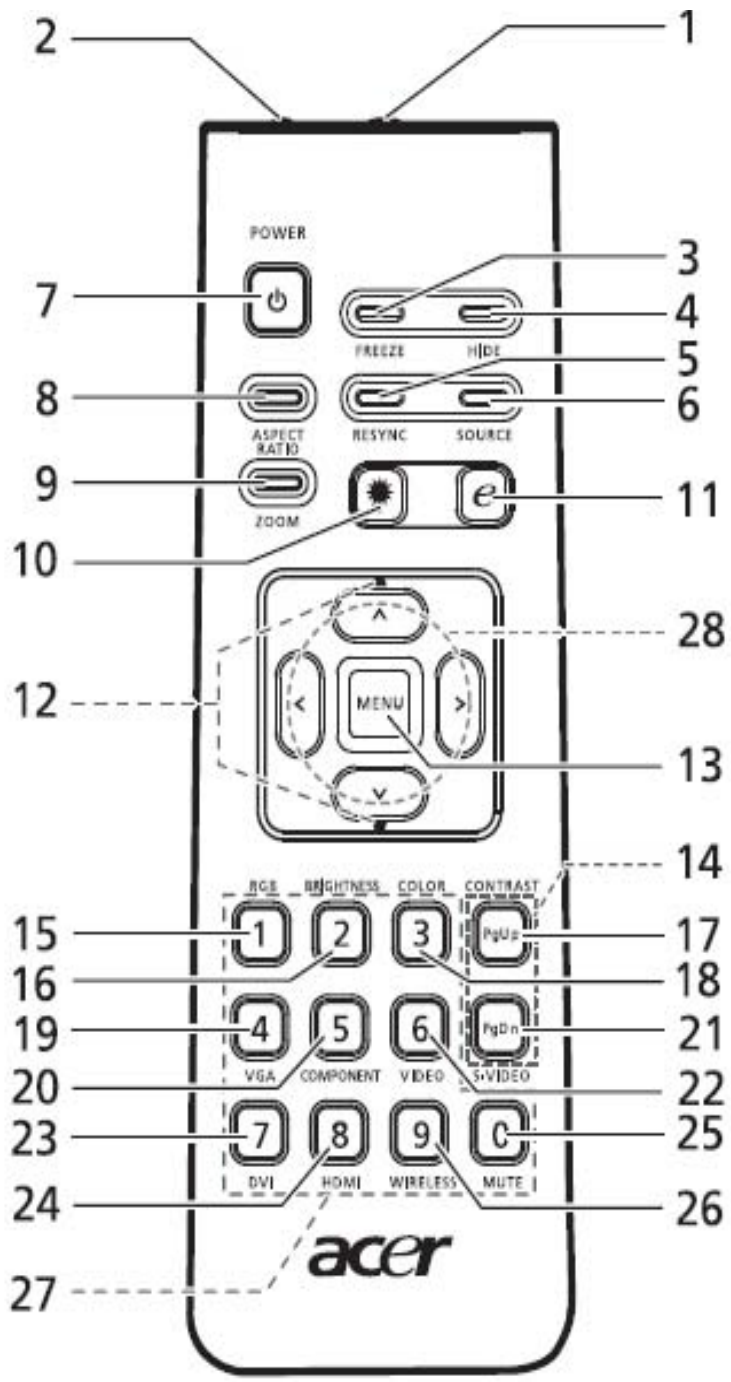

| Item | Function | Description |
|------|------------------------------|--|
| 1 | LAMP | Lamp Indicator LED |
| 2 | TEMP | Temp Indicator LED |
| 3 | SOURCE | Press "SOURCE" to choose RGB, S-Video, Composite and HDMI™ sources. |
| 4 | Empowering key | Unique Acer functions: eOpening, eView, eTimer. |
| 5 | RESYNC | Automatically synchronizes the projector to the input source |
| 6 | POWER | Power/Standby/Power Indicator LED. See the contents in "Turning the Projector On/Off" section. |
| 7 | MENU | <ul style="list-style-type: none"> • Press "MENU" to launch the Onscreen display (OSD) menu, back to the previous step for the OSD menu operation or exit the OSD menu. • Confirm your selection of items. |
| 8 | Keystone | Adjusts the image to compensate for distortion caused by tilting the projector (± 40 degrees). |
| 9 | Four directional select keys | Use to     select items or make adjustments to your selection. |

Remote Control Layout (for P3150/P3250/P3150 Refresh/P3250 Refresh)









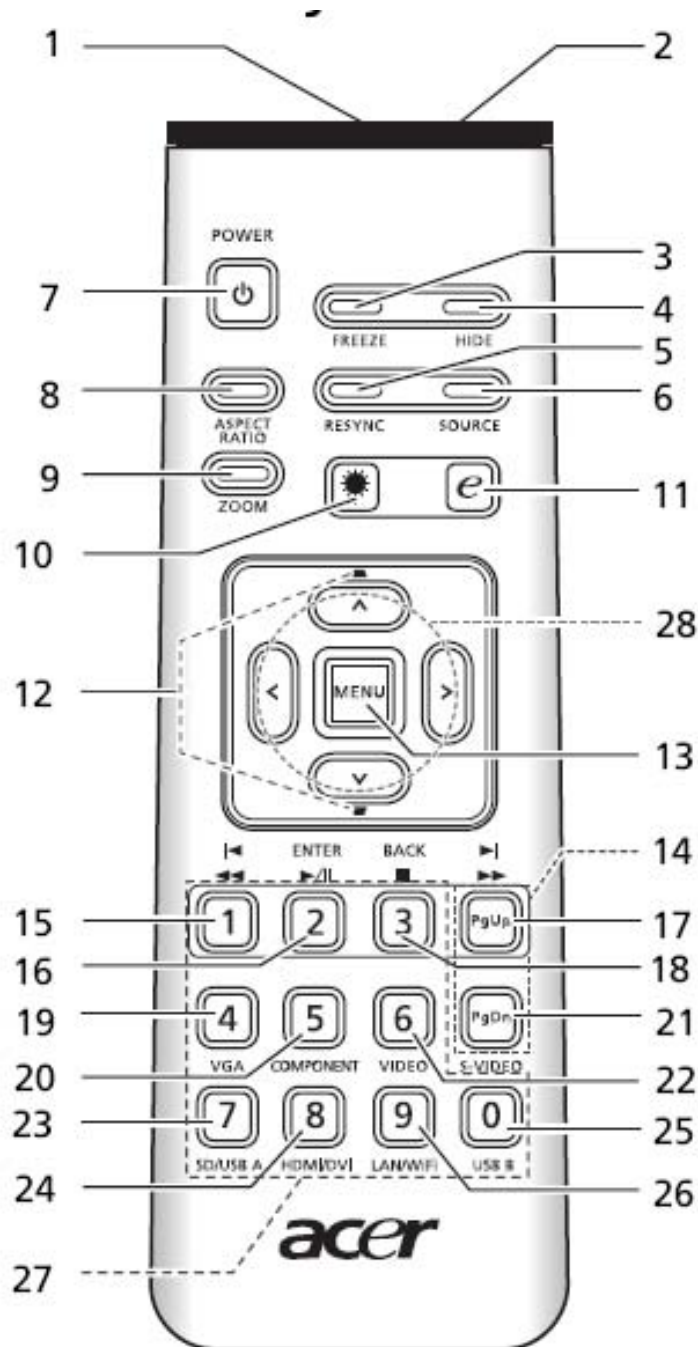



| Item | Icon | Function | Description |
|------|---|----------------------|--|
| 1 | | Infrared transmitter | Sends signals to the projector. |
| 2 | | Laser pointer | Aim the remote at the viewing screen |
| 3 | | FREEZE | To pause the screen image. |
| 4 | | HIDE | Momentarily turns off the video. Press "HIDE" to hide the image, press again to display the image. |
| 5 | | RESYNC | Automatically synchronizes the projector to the input source. |
| 6 | | SOURCE | Press "SOURCE" to choose from RGB, Component-p, Component-i, S-Video, Composite, Video and HDTV sources. |
| 7 |  | POWER | Refer to the "Turning the Projector On/Off" section. |
| 8 | | ASPECT RATIO | To choose the desired aspect ratio (Auto/4:3/16:9). |
| 9 | | ZOOM | Zooms the projector display in or out.. |
| 10 |  | Laser button | Aim the remote at the viewing screen, press and hold this button to activate the laser pointer. This function is not supported in Japanese market. |
| 11 |  | Empowering key | Unique Acer functions: eOpening, eView, eTimer Management |
| 12 |  | KEYSTONE | Adjusts the image to compensate for distortion caused by tilting the projector (± 40 degrees). |
| 13 | | MENU | <ul style="list-style-type: none"> Press "MENU" to launch the Onscreen display (OSD) menu, back to the previous step for the OSD menu operation or exit the OSD menu. Confirm your selection of items. |
| 14 |  | PAGE | For computer mode only. Use this button to select the next or previous page. This function is only available when connected to a computer via a USB cable. |
| 15 | | RGB | Press "RGB" for true-color optimization. |
| 16 | | BRIGHTNESS | Press "BRIGHTNESS" to adjust the brightness of the image. |
| 17 | | CONTRAST | Use the "CONTRAST" option to control the difference between the lightest and darkest parts of the picture. |
| 18 | | COLOR | Press "COLOR" to adjust the color temperature of image. |
| 19 | | VGA | Press "VGA" to change source to the VGA connector. This connector supports analog RGB, YPbPr (480p/576p/720p/1080i), YCbCr (480i/576i) and RGBsync. |
| 20 | | COMPONENT | Press "COMPONENT" to change source to Component video. This connection supports YPbPr (480p/576p/720p/1080i) and YCbCr (480i/576i). |
| 21 | | S-VIDEO | To change source to S-Video. |
| 22 | | VIDEO | To change source to COMPOSITE VIDEO. |
| 23 | | DVI | No DVI function. |
| 24 | | HDMI™ | To change source to HDMI™. |
| 25 | | MUTE | To turn on/off the volume. |

| Item | Icon | Function | Description |
|------|---|------------------------------|--|
| 26 | | WIRELESS | Press "WIRELESS" to display the image which is wirelessly transmitted from the PC to the projector via the "Acer eProjection Management" utility. (for wireless model) |
| 27 | | KeyPad 0~9 | Press "0~9" to input a password in the "Security settings". |
| 28 |  | Four directional select keys | Use up, down, left, right buttons to select items or make adjustments to your selection. |

Remote Control Layout (for P3251)



| Item | Icon | Function | Description |
|------|---|----------------------|--|
| 1 | | Infrared transmitter | Sends signals to the projector. |
| 2# | | Laser pointer | Aim the remote at the viewing screen |
| 3 | | FREEZE | To pause the screen image. |
| 4 | | HIDE | Momentarily turns off the video. Press "HIDE" to hide the image, press again to display the image. |
| 5 | | RESYNC | Automatically synchronizes the projector to the input source. |
| 6 | | SOURCE | Press "SOURCE" to choose from RGB, Component-p, Component-i, S-Video, Composite, Video and HDTV sources. |
| 7 |  | POWER | Refer to the "Turning the Projector On/Off" section. |
| 8 | | ASPECT RATIO | To choose the desired aspect ratio (Auto/4:3/16:9). |
| 9 | | ZOOM | Zooms the projector display in or out.. |
| 10# |  | Laser button | Aim the remote at the viewing screen, press and hold this button to activate the laser pointer. This function is not supported in Japanese market. |
| 11 |  | Empowering key | Unique Acer functions: eOpening, eView, eTimer Management |
| 12 |  | KEYSTONE | Adjusts the image to compensate for distortion caused by tilting the projector (± 40 degrees). |
| 13 | | MENU | <ul style="list-style-type: none"> Press "MENU" to launch the Onscreen display (OSD) menu, back to the previous step for the OSD menu operation or exit the OSD menu. Confirm your selection of items. |
| 14 |  | PAGE | For computer mode only. Use this button to select the next or previous page. This function is only available when connected to a computer via a USB cable. |
| 15 |  | Pre./Rewind | Press "Pre./Rewind" to go to previous index or press continuously to rewind the playing media file. |
| 16 |  | Enter/Play/Pause | Press "Enter/Play/Pause" to play/pause media file. |
| 17 |  | Next/Fastforward | Press "Next/Fast-forward" once to go to next index or press continuously to fast-forward the playing media file. |
| 18 |  | Back/Stop | Press "Back/Stop" to stop playing media file or go back to upper data folder. |
| 19 | | VGA | Press "VGA" to change source to the VGA connector. This connector supports analog RGB, YPbPr (480p/576p/720p/1080i), YCbCr (480i/576i) and RGBsync. |
| 20 | | COMPONENT | No COMPONENT function. |
| 21 | | S-VIDEO | Press "S-VIDEO" to change source to S-Video. |
| 22 | | VIDEO | Press "VIDEO" to change source to composite video. |
| 23 | | SD/USB A | Press "SD/USB A" to toggle between SD and USB A sources. This projector supports various file formats of photo/audio/video. |

| Item | Icon | Function | Description |
|------|---|------------------------------|--|
| 24 * | | HDMI™/DVI | Press “HDMI™/DVI” to change source to HDMI™. |
| 25 | | USB B | No USB B function. |
| 26 | | LAN/WiFi | No LAN/WiFi function. |
| 27 | | KeyPad 0~9 | Press “0~9” to input a password in the “Security settings”. |
| 28 |  | Four directional select keys | Use up, down, left, right buttons to select items or make adjustments to your selection. |



Note: “#” Japan area is not supported.
 “*” No DVI function



Connecting the Projector

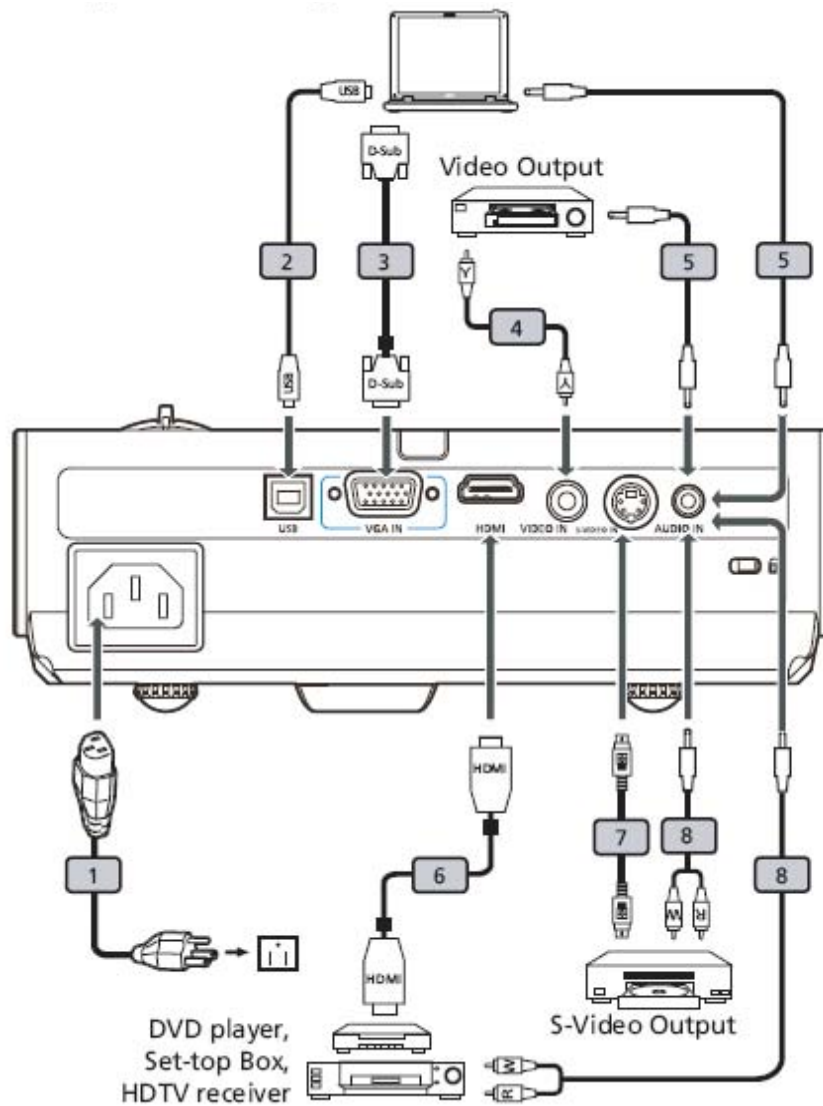

| Item | Description | Item | Description |
|------|-----------------------|------|-----------------------|
| 1 | Power cord | 5 | Audio cable Jack/Jack |
| 2 | USB cable | 6 | HDMI cable |
| 3 | VGA cable | 7 | S-Video cable |
| 4 | Composite video cable | 8 | Audio cable Jack/RCA |



Note: To ensure the projector works well with your computer, please make sure the timing of the display mode is compatible with the projector.

System Block Diagram

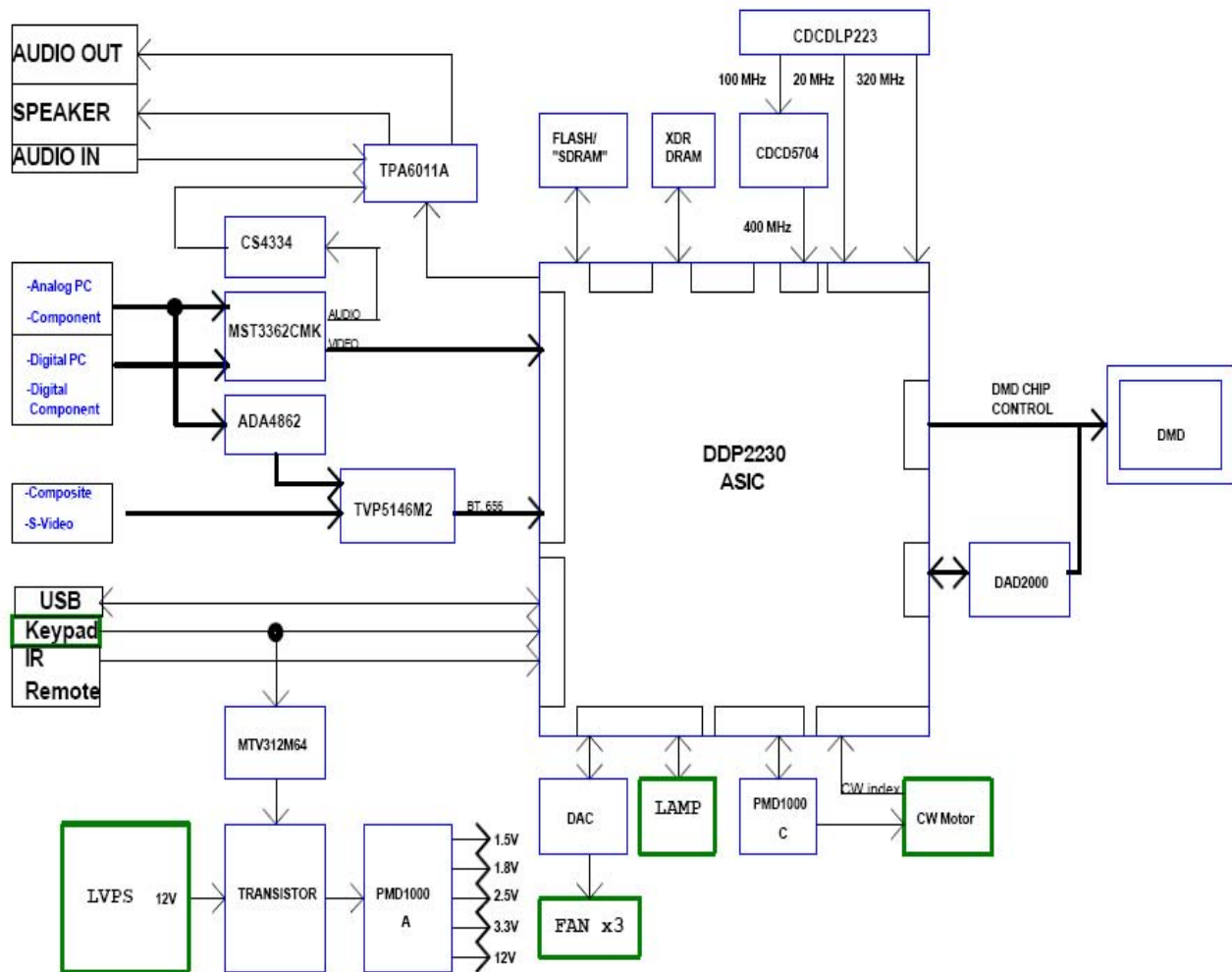

Disassembly & Assembly Process

2-1 Equipment Needed & Product Overview

1. Screw Bit (+) :107
2. Hex Sleeves 5mm
3. Long Nose Nipper
4. Screw Bit (+) :102
5. Hex Sleeves 7mm
6. Tweezers
7. P3150/P3250/P3150 refresh/P3250 refresh/P3251 unit

** Before you start: This process is protective level II. Operators should wear electrostatic chains.*

** Note: 1. If you need to replace the main board, you have to get into service mode and record the lamp usage hour. please refer to section 2-21.*

2. The disassembly and assembly process for P3150/P3250/P3150 refresh/P3250 refresh/P3251 is the same. Here, we take P3250 as an example.



2-2 Disassemble Lamp Cover Module

1. Turn over the projector
2. Unscrew 2 screws (as red circle)
3. Disassemble the Lamp Cover Module



2-3 Disassemble Lamp Module

1. Unscrew 2 screws (as red circle)
2. Disassemble Lamp Module



2-4 Disassemble Top Cover Module

1. Unscrew 5 screws (as red circle)
2. Unscrew 2 Hex screws (as yellow circle)
3. Unplug 1 FPC cable (as red square)
4. Disassemble Top cover



2-5 Disassemble Key Pad Board Module

1. Unscrew 4 screws (as red circle)
2. Separate Key Pad Button and Key Pad Board



2-6 Disassemble Zoom Ring Module

1. Unscrew 3 screws (as yellow circle)
2. Disassemble Zoom Ring Module
3. Release 2 tenons to outward (as red square)
4. Separate Zoom Ring and Zoom Ring Holder

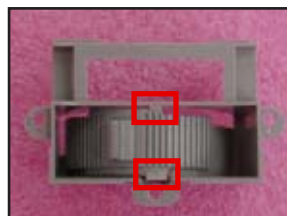

2-7 Disassemble Main Board Module

1. Tear off 2 Mylars (as red square)
2. Unplug 5 connectors (as green square)
3. Push Main Board Module (as red arrow) to unplug 1 connector (as yellow square)
4. Unplug 6 connectors (as orange square)

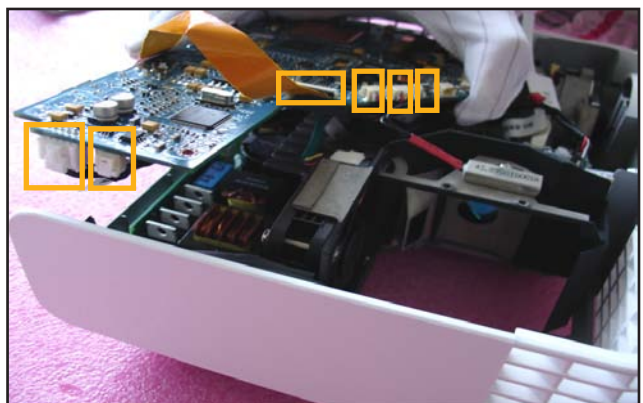
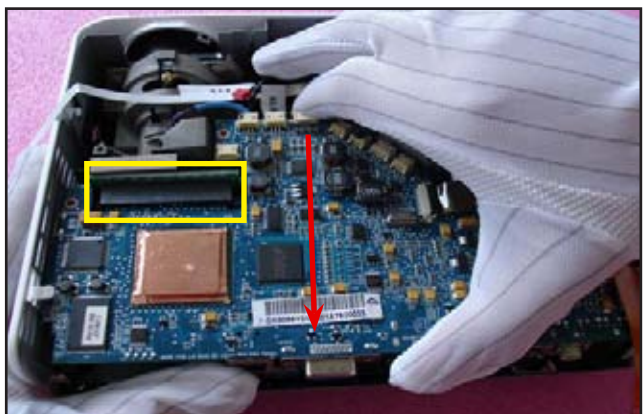
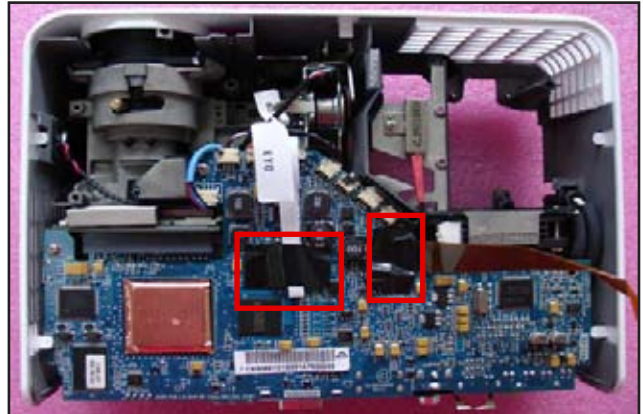

5. Disassemble Main Board Module

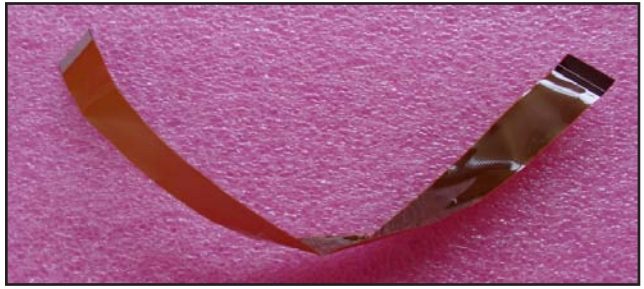

6. Unscrew 2 screws(as red circle) to disassemble the Daughter Board. (only for P3251)

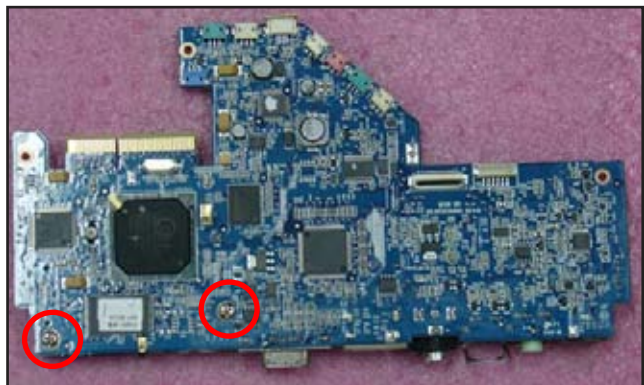

2-8 Disassemble Color Wheel Module

1. Unscrew 2 screws (as red circle)
2. Disassemble Color Wheel Module
3. Unscrew 1 screw (as yellow circle)
4. Disassemble Photo Sensor Board

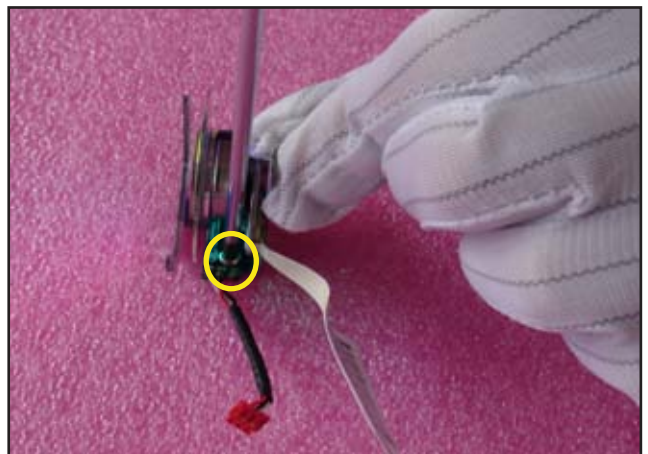
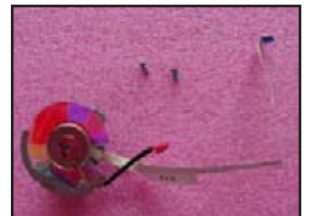
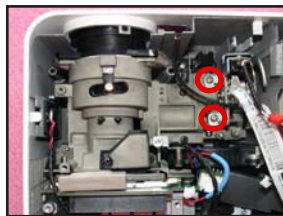
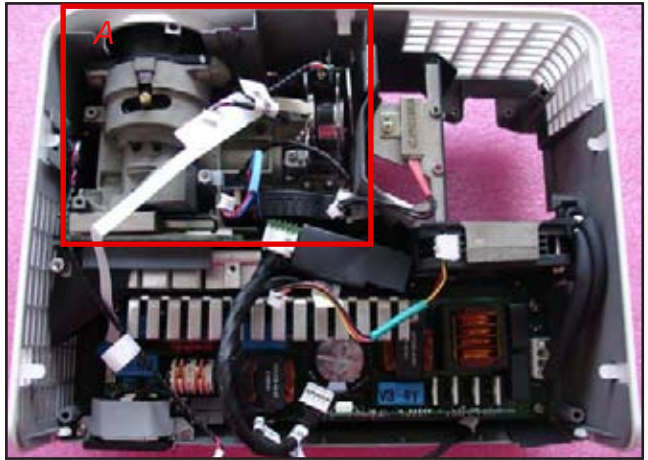

2-9 Disassemble Front Cover Module

1. Release 6 tenons (as red circle)
2. Push the front cover forward to disassemble front cover module

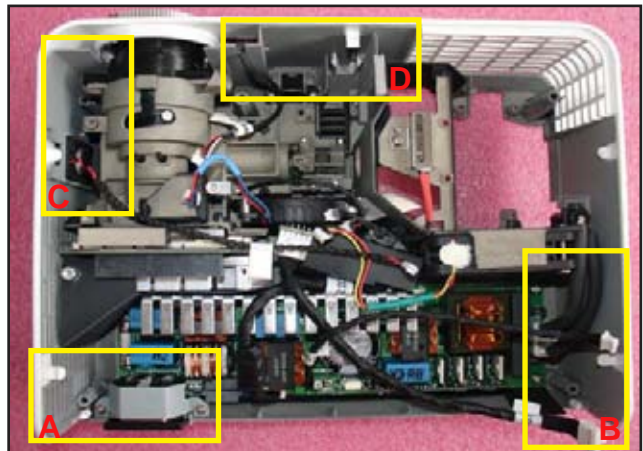

A



B



C



D



2-10 Disassemble Ballast Module

1. Unplug 2 cables (as red square)
2. Unscrew 3 screws (as red circle)
3. Disassemble AC Inlet Bracket
4. Unscrew 3 screws (as yellow circle)
5. Disassemble Ballast Module
6. Tear off 1 Mylar

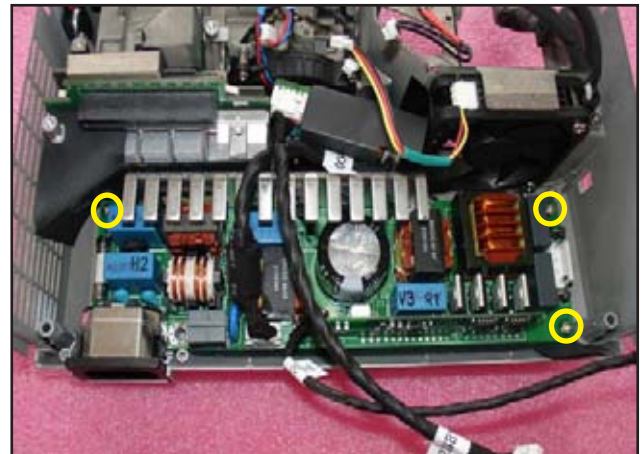
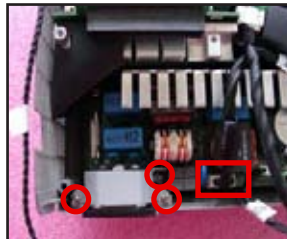
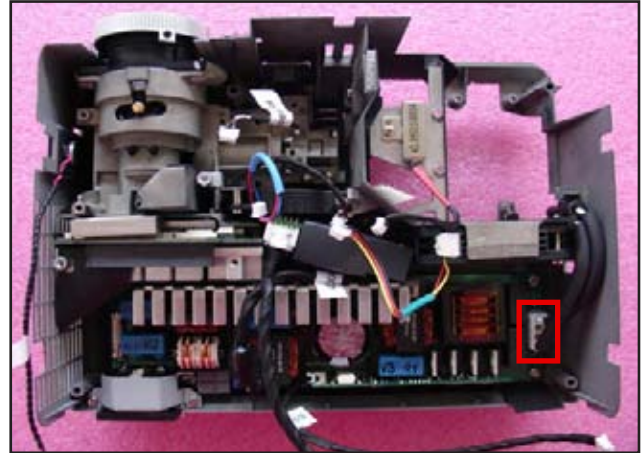

2-11 Disassemble DC-DC Module

1. Unscrew 1 screw (as red circle)
2. Disassemble DC-DC Module
3. Unplug 2 cables (as red square)

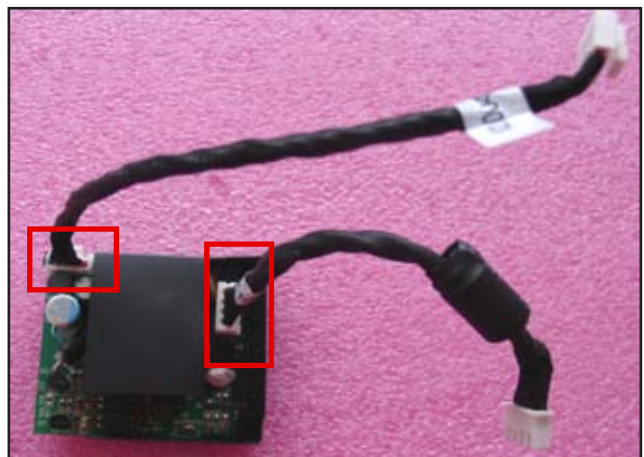
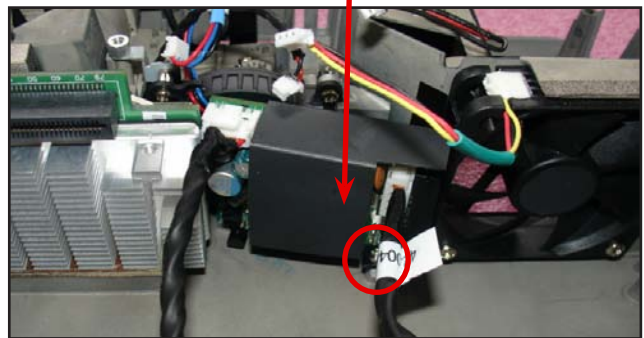
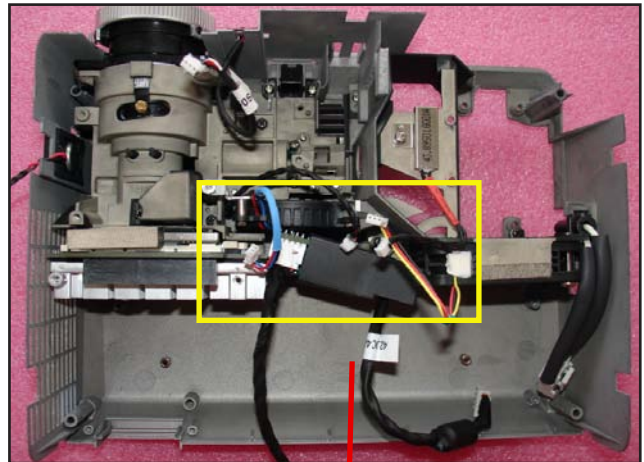

2-12 Disassemble Thermal Switch Module

1. Unscrew 1 screw (as red circle)
2. Disassemble Thermal Switch

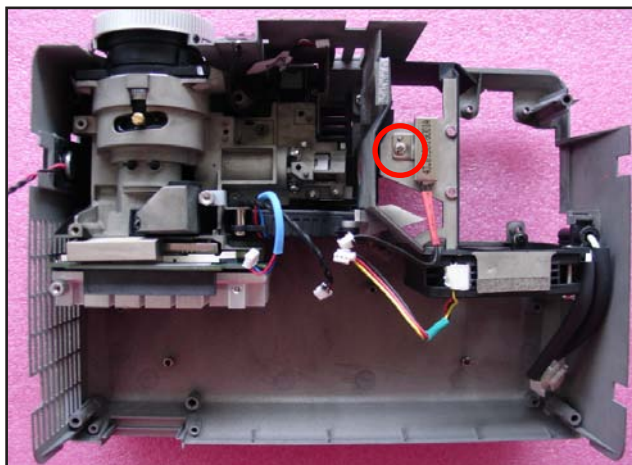

2-13 Disassemble Lamp Blower Module and System Fan Module

1. Unscrew 4 screws (as red circle)
2. Disassemble Lamp Blower Module and System Fan Module
3. Unscrew 3 screws (as yellow circle)
4. Separate Lamp Blower , Lamp Blower Duct and Lamp Blower Holder
5. Tear off 1 mylar (as red square)
6. Unscrew 3 screws (as green circle)
7. Separate System Fan and Lamp Housing

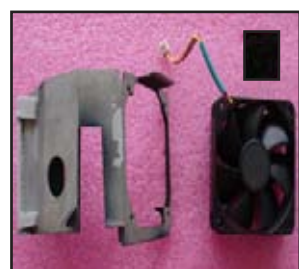
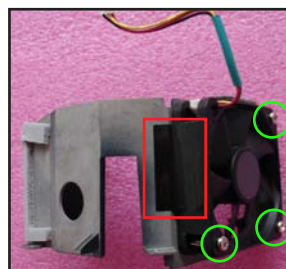
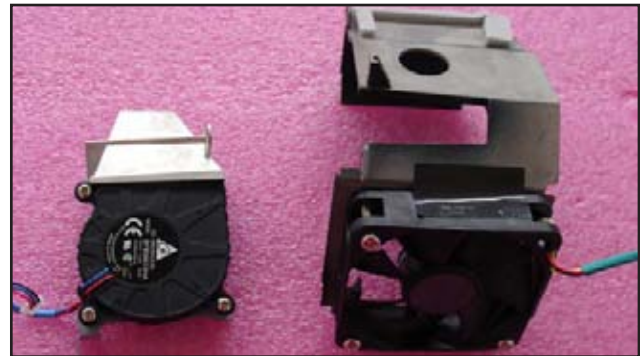
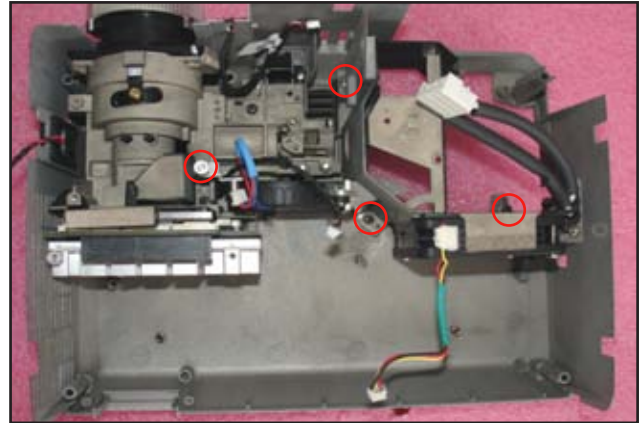

2-14 Disassemble Lamp to Ballast Cable

1. Unscrew 1 screw (as red circle)
2. Unplug Lamp to Ballast Cable

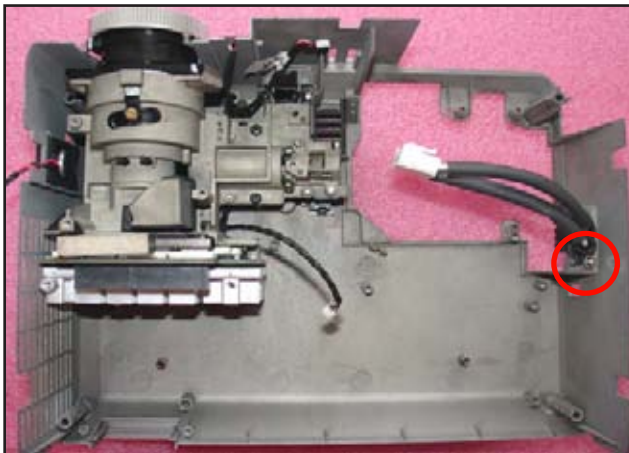

2-15 Disassemble Engine Module

1. Unscrew 4 screws (as red circle)
2. Disassemble Engine Module
3. Unscrew 3 screws (as yellow circle)
4. Disassemble Focus Ring

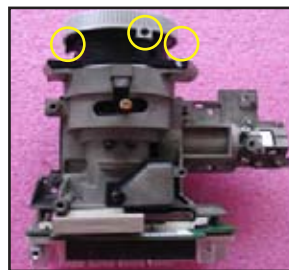
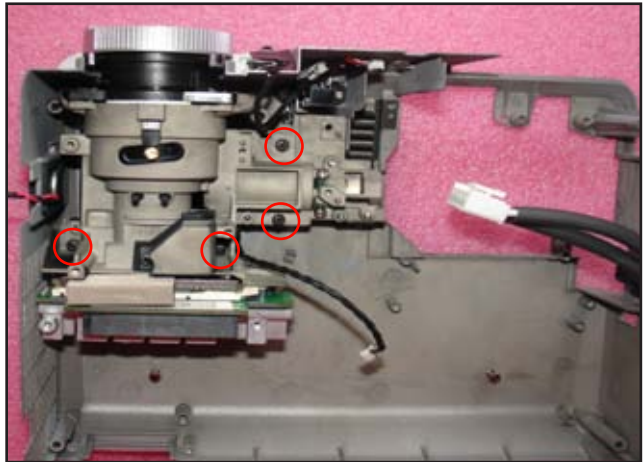

2-16 Disassemble DMD Board and DMD Chip

1. Unscrew 2 screws (as blue circle)
2. Disassemble Heat sink ,DMD Mask and DMD Rubber
3. Rotate DMD Chip Lock counterclockwise (as red arrow)
4. Separate DMD Board and DMD Chip

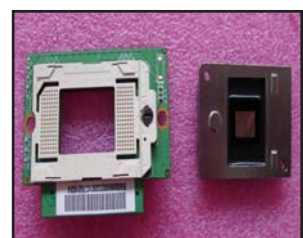
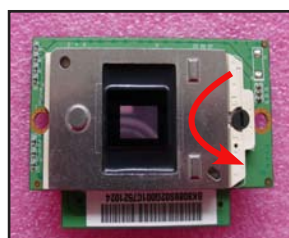
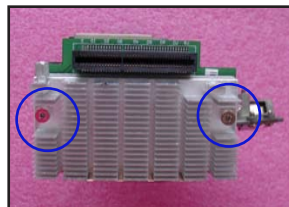

2-17 Disassemble Speaker Module

1. Disassemble Speaker Module
2. Separate Speaker and Rubber

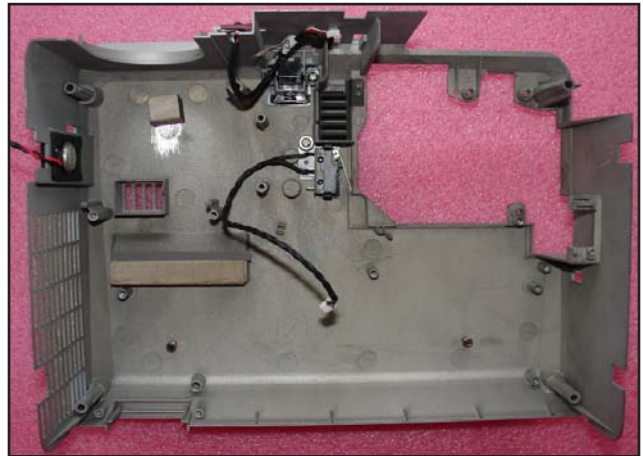

2-18 Disassemble Interrupt Switch Module

1. Unscrew 1 screw (as red circle)
2. Release 2 tenons (as yellow circle)
3. Separate Interrupt Switch and Interrupt Switch Holder

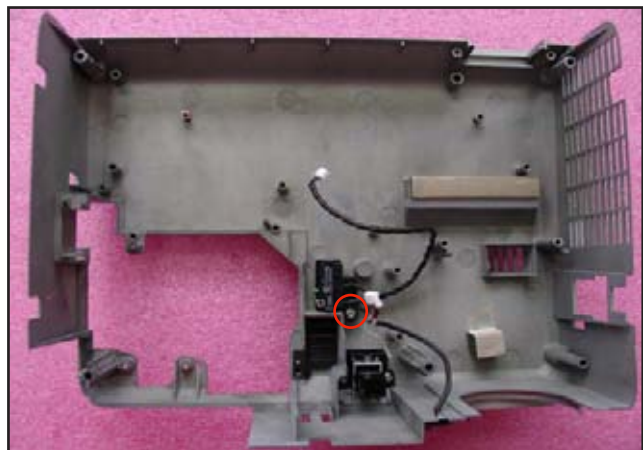

2-19 Disassemble IR Sensor Module

1. Tear off 1 Mylar (as red square)
2. Disassemble IR Sensor Board

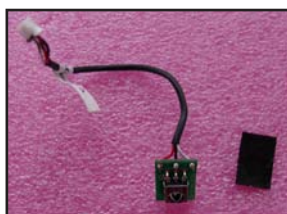
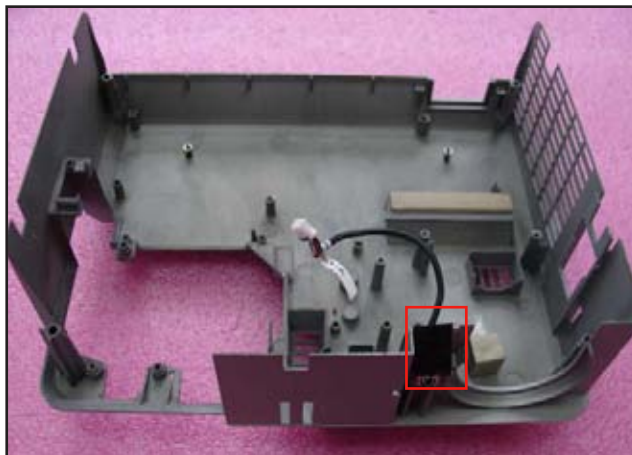

2-20 Rod Adjustment

1. Environment adjustment

- The distance between the engine and the screen is 2.36 M
- This process should be done at a dark environment. (under 5 Lux)

2. Procedure adjustment

- Change the screen to “white screen.”
- Adjust the screws by using the rod on the engine module to readjust the image. (adjust until the yellowish or bluish parts disappeared.)

3. Abnormal image inspection

- It should not have any abnormal color at the rim of the image by estimating through the eyes.

Note: - To avoid over adjust the rod.

- *“Screw 1” should be adjusted first, and then adjust the “Screw2”.After the adjustment, use the glue to fix the screws*

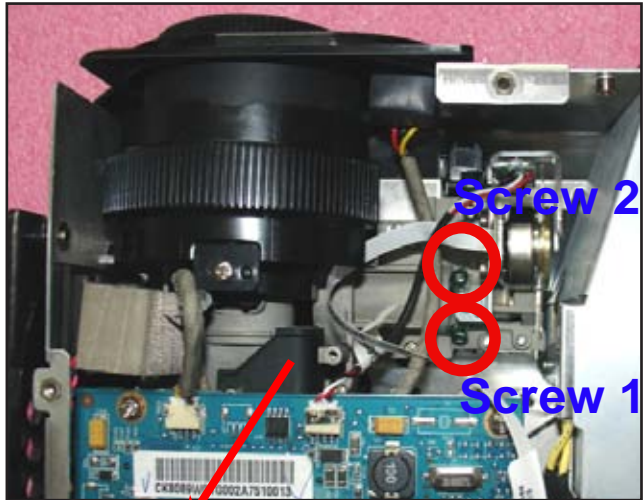

2-21 Re-write Lamp Usage Hour

1. Get into service mode

- Press (power→left→left→menu) to get into service mode

2. Choose RD Menu

3. Choose Lamp life warning test

4. Use left or right key to re-write the lamp hour back to previous lamp usage hour

5. Choose Return to Service Menu

6. Choose Exit

*Note: left key = decrease lamp hour
right key = increase lamp hour*

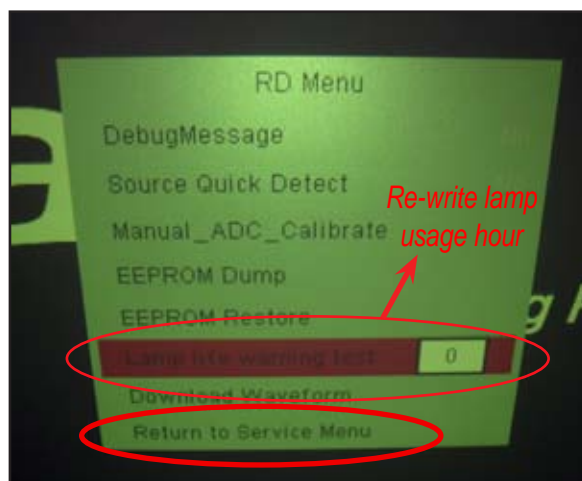
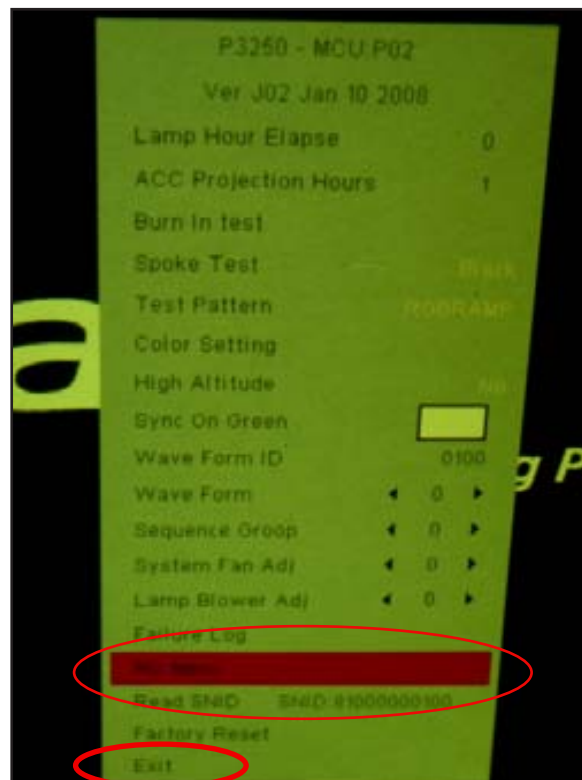

2-22 Assemble IR Sensor Module

1. Assemble IR Sensor Board in red square
2. Stick 1 Mylar.

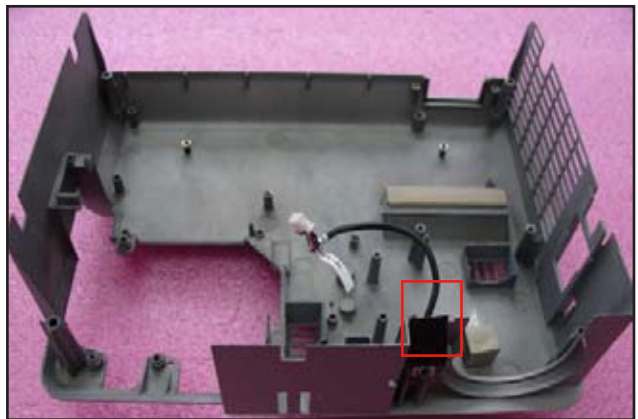
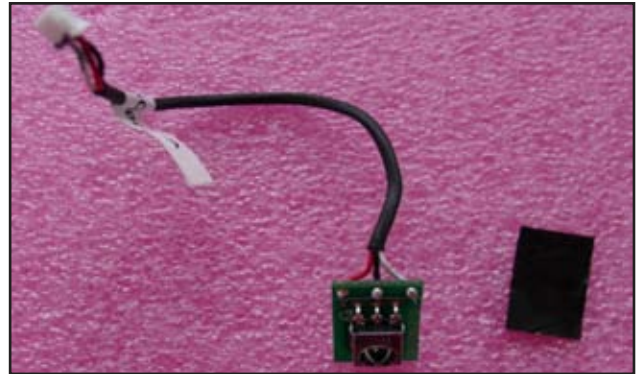

2-23 Assemble Interrupt Switch Module

1. Assemble Interrupt Switch
2. Screw 1 screw (as red circle)

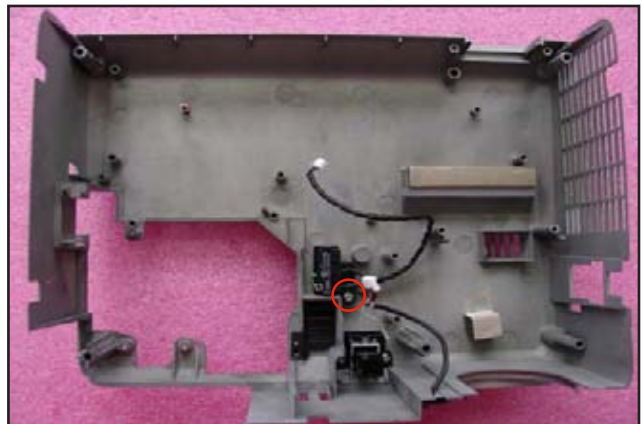
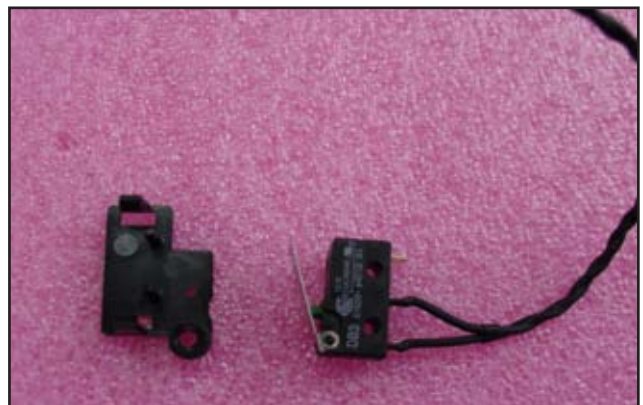

2-24 Assemble Speaker Module

1. Assemble Speaker and Rubber
2. Assemble Speaker Module

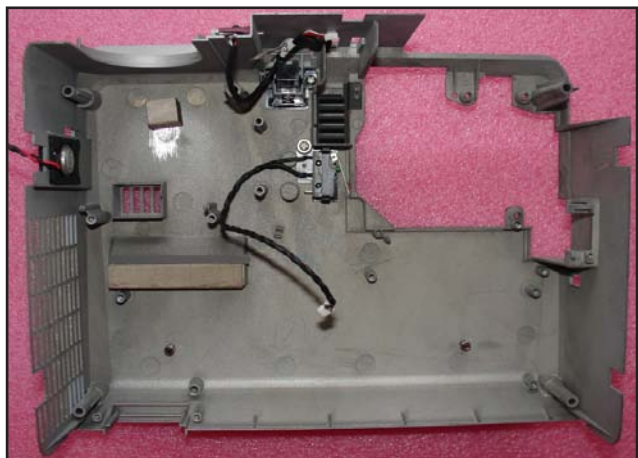
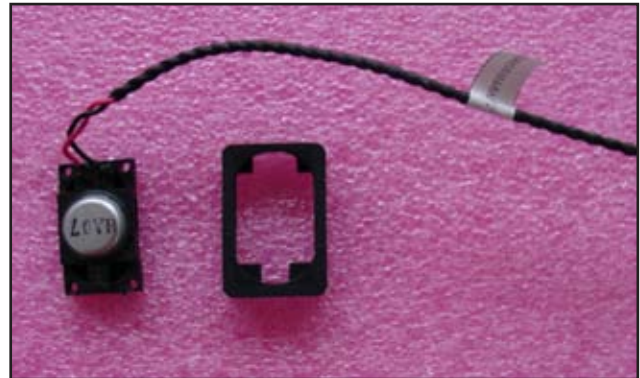

2-25 Assemble DMD Board and DMD Chip

1. Assemble DMD Chip and rotate DMD Chip Lock clockwise (as red arrow)

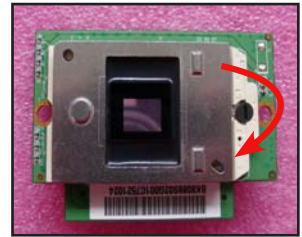
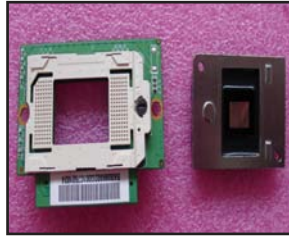

2. Assemble DMD Mask ,DMD Rubber and Heat sink

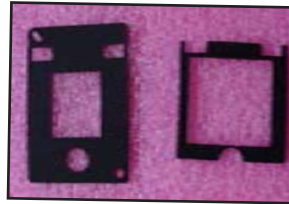

3. Screw 2 screws (as blue circle)



2-26 Assemble Engine Module

1. Assemble Focus Ring

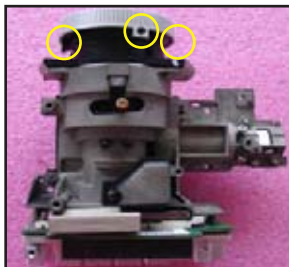

2. Screw 3 screws (as yellow circle)

3. Assemble Engine Module

4. Screw 4 screws (as red circle)

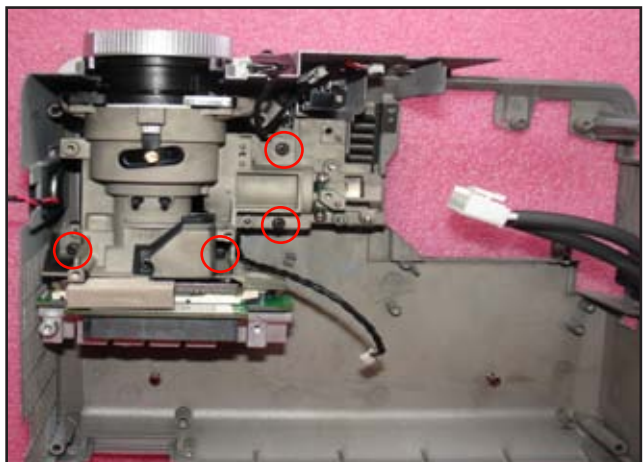

2-27 Assemble Lamp to Ballast Cable

1. Plug Lamp to Ballast Cable in yellow square

2. Screw 1 screw (as red circle)

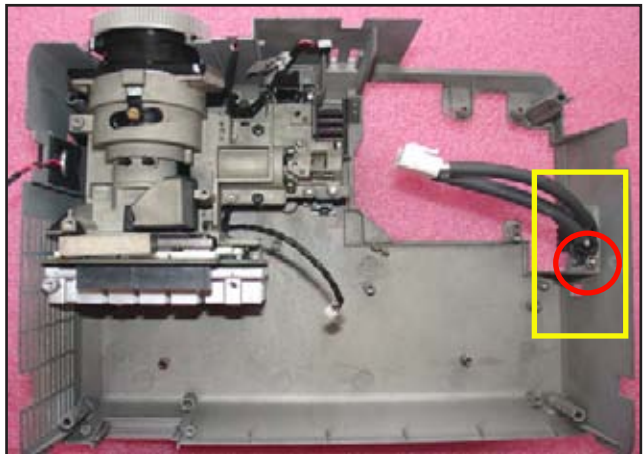

2-28 Assemble Lamp Blower Module and System Fan Module

1. Assemble System Fan and Lamp Housing

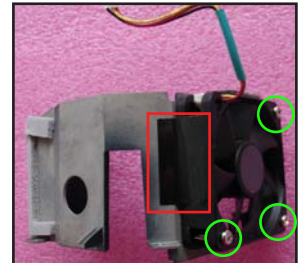
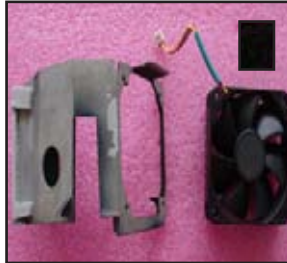

2. Screw 3 screws (as green circle)

3. Stick 1 mylar (as red square)



4. Assemble Lamp Blower , Lamp Blower Duct and Lamp Blower Holder

5. Screw 3 screws (as yellow circle)

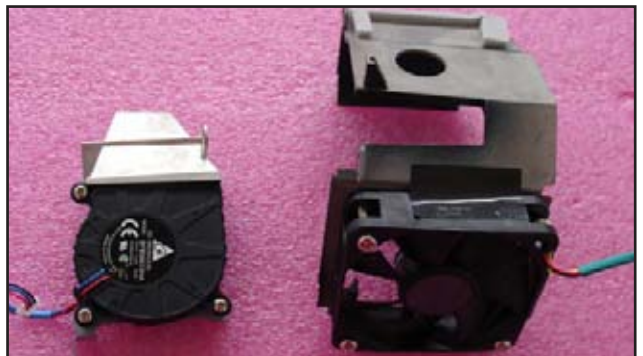

6. Assemble Lamp Blower Module and System Fan Module

7. Screw 4 screws (as red circle)

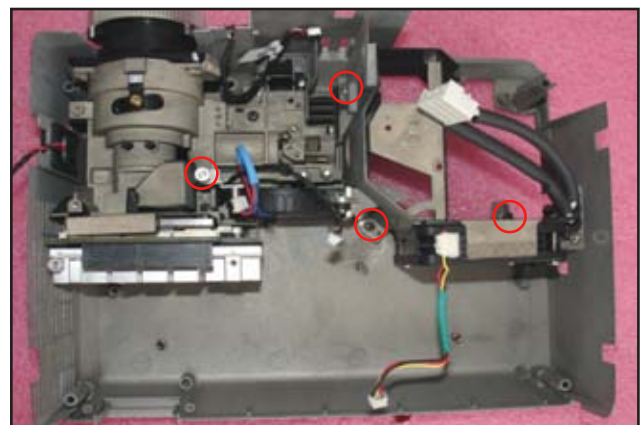

2-29 Assemble Thermal Switch Module

1. Assemble Thermal Switch



2. Screw 1 screw (as red circle)

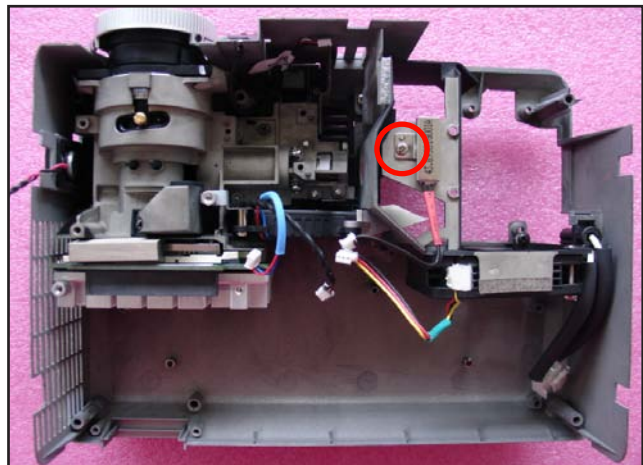

2-30 Assemble DC-DC Module

1. Plug 2 cables in red square
2. Assemble DC-DC Module
3. Screw 1 screw (as red circle)

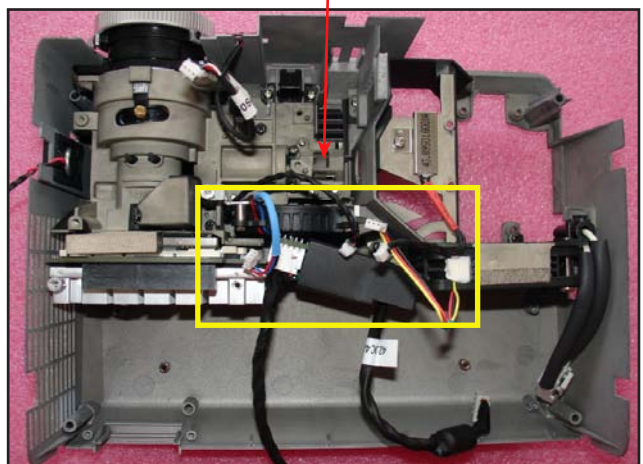
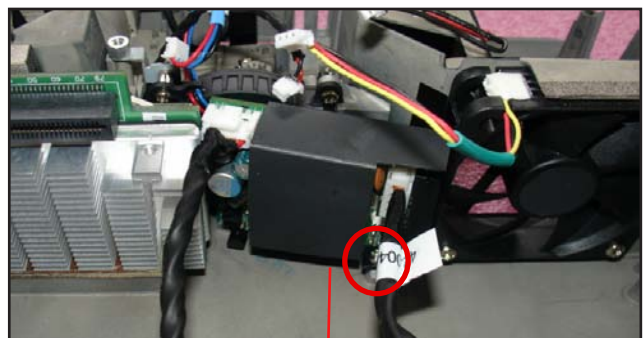
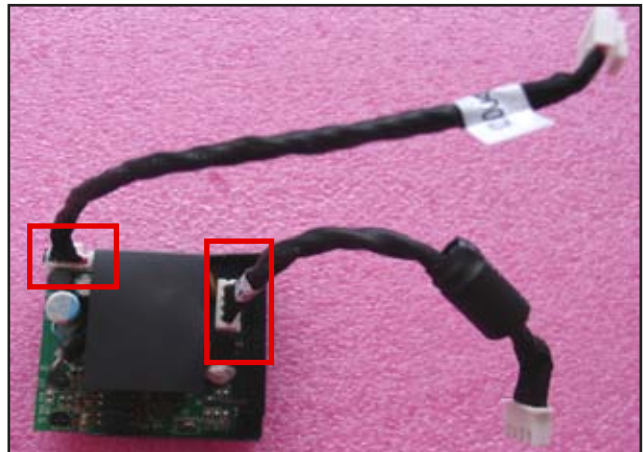

2-31 Assemble Ballast Module

1. Stick 1 mylar under Ballast Module



2. Assemble Ballast Module

3. Screw 3 screws (as yellow circle)

4. Assemble AC Inlet Bracket

5. Screw 3 screws (as red circle)

6. Plug 2 cables (as red square)

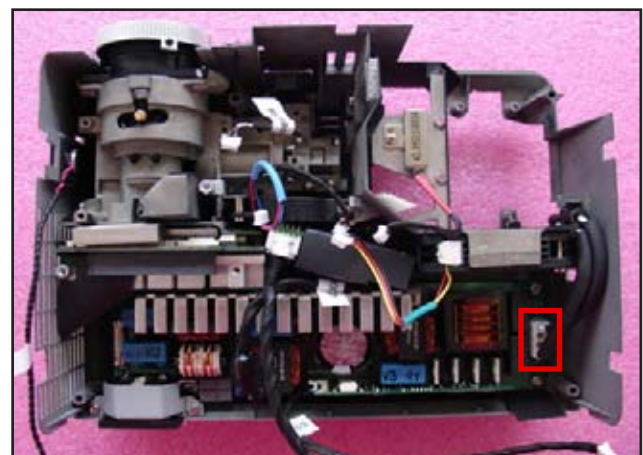
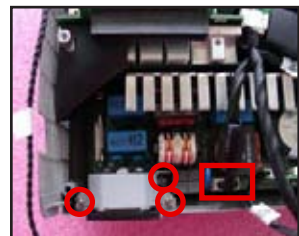
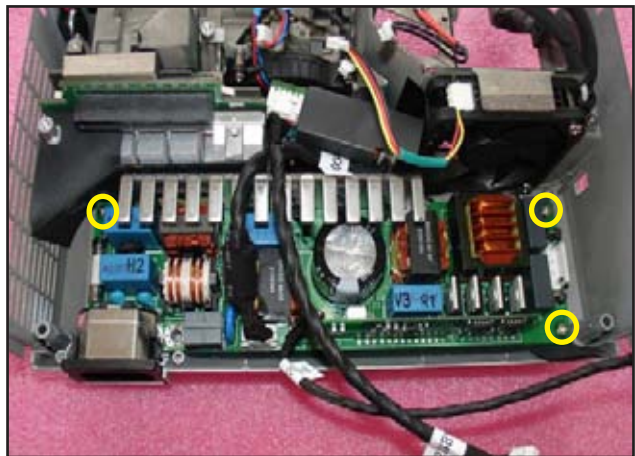

2-32 Assemble Front Cover Module

1. Assemble Front Cover Module

Note: there are 6 tenons (as red circle)



A



B



C



D

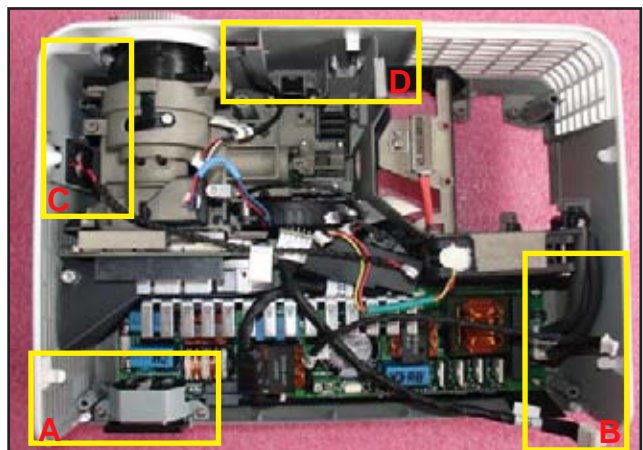

2-33 Assemble Color Wheel Module

1. Assemble Photo Sensor Board
2. Screw 1 screw (as yellow circle)
3. Assemble Color Wheel Module
4. Screw 2 screws (as red circle)

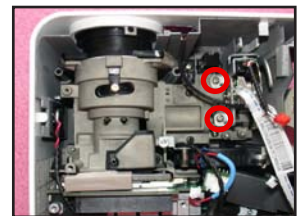
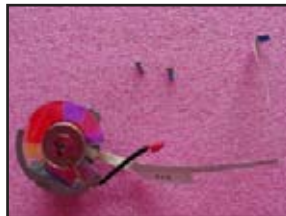
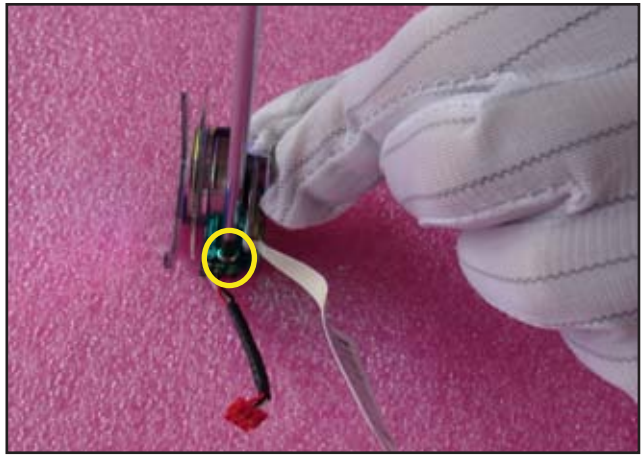
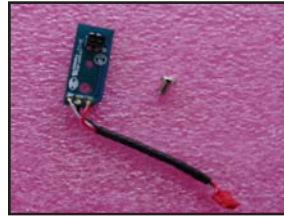

A

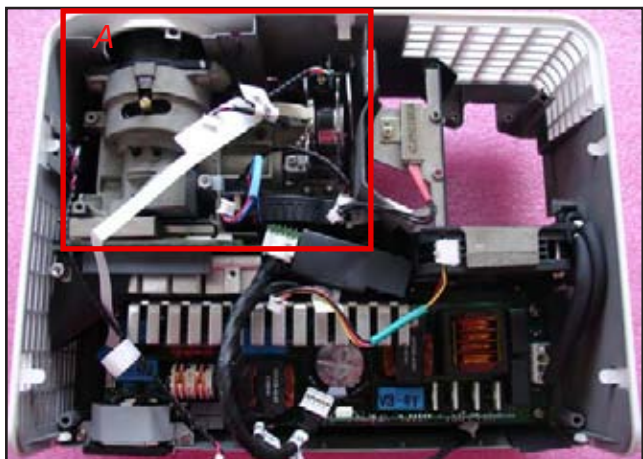

2-34 Assemble Main Board Module



1. Screw 2 screws (as red circle) to assemble the Daughter Board. (only for P3251)

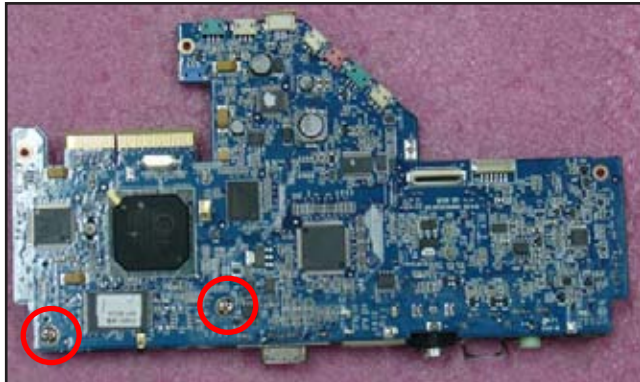

2. Plug 6 connectors (as orange square)

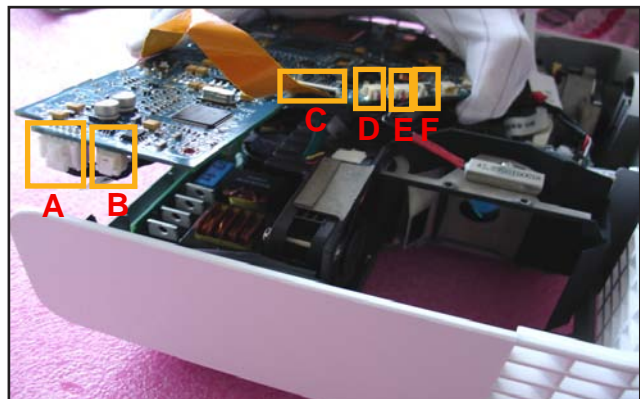

3. Assemble Main Board Module (as red arrow) and plug 1 connector (as yellow square)

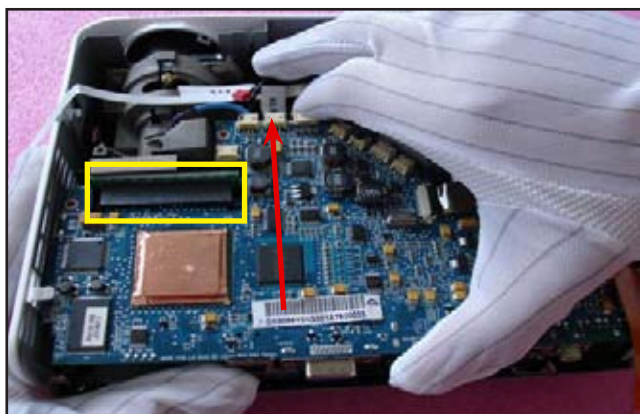

4. Plug 5 connectors (as green square)

Note: - The arrangement of cables are as follows:

- A: DC-DC 5 pin cable
- B: Ballast 5 pin cable
- C: FPC
- D: Speaker cable
- E: System Fan cable
- F: Thermal Switch cable
- G: Blower cable
- H: IR Sensor Board cable
- I: Photo Sensor Board cable
- J: Color Wheel FPC
- K: Interrupt Switch cable

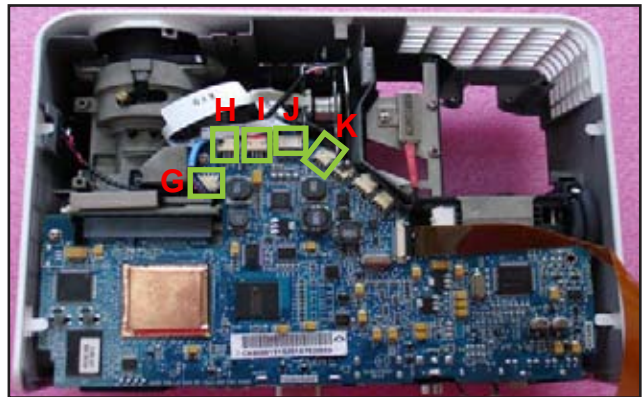

5. Stick 2 Mylars (as red square)

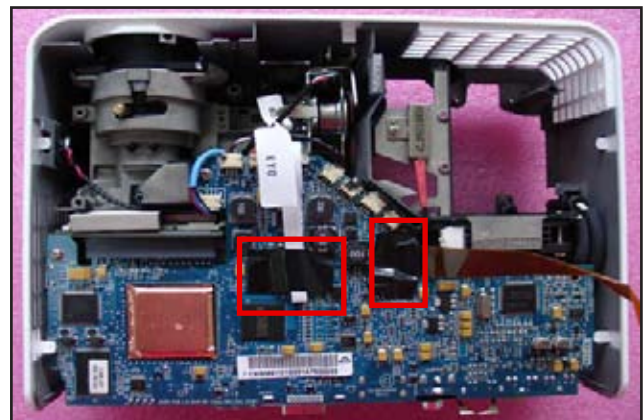

2-35 Assemble Zoom Ring Module

1. Assemble Zoom Ring on Zoom Ring Holder

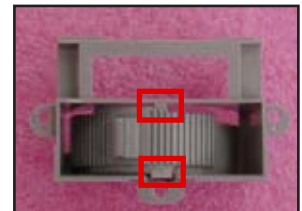

2. Assemble Zoom Ring Module on Top Cover Module

3. Screw 3 screws (as yellow circle)

Note: There are two tenons (as red square)



2-36 Assemble Key Pad Board Module

1. Assemble Key Pad Button and Key Pad Board on Top Cover Module
2. Screw 4 screws (as red circle)



2-37 Assemble Top Cover Module

1. Plug 1 FPC cable (as red square)



2. Assemble Top cover Module

3. Screw 2 Hex screws (as yellow circle)

4. Screw 5 screws (as red circle)



2-38 Assemble Lamp Module

1. Assemble Lamp Module



2. Screw 2 screws (as red circle)



2-39 Assemble Lamp Cover Module

1. Assemble Lamp Cover Module



2. Screw 2 screws (as red circle)

3. Turn over the projector, assemble OK



Troubleshooting

3-1 LED Lighting Message

| Message | Power LED | Lamp LED | Temp LED |
|--|---|----------------------|----------------------|
| Plug-in Power Cord | Flash Red (100ms) | Flash Red (100ms) | Flash Red (100ms) |
| Standby Mode | Red | X | X |
| Power button ON | Blue | X | X |
| F/W Download Mode | Red | Red | Red |
| Lamp Ignited | Flash Blue 0.5 second H(On), 0.5 second L(Off) | X | X |
| Cooling Down | Flash Red 0.5 second H(On), 0.5 second L(Off) | X | X |
| Warning for Temperature High(On Event) | Blue | X | Red |
| Warning for Temperature High(On Standby) | Red | X | Red |
| Error for Lamp Fail(On Event) | Blue | Red | X |
| Error for Lamp Fail(On Standby) | Red | Red | X |

| Message | Power LED | Lamp LED | Temp LED |
|--|--|---|---|
| Error for Fan Fail(On Event) | Blue | X | Flash Red 0.5 second H(On), 0.5 second L(Off) |
| Error for Fan Fail(On Standby) | Red | X | Flash Red 0.5 second H(On), 0.5 second L(Off) |
| Error for Color Wheel fail / Striking Lamp Fail(On Event) | Blue | Flash Red 0.5 second H(ON), 0.5 second L(OFF) | X |
| Error for Color Wheel fail / Striking Lamp Fail(On Standby) | Red | Flash Red 0.5 second H(ON), 0.5 second L(OFF) | X |
| Burn In Lamp On | Flash Red 3 second H(On), 1 second L(Off) | X | X |
| Burn In Lamp Off | Flash Red 1 second H(On), 3 second L(Off) | X | X |
| Random Burn In | X | Red | Red |

(R) - RED
(B) - BLUE
(F) - FLASH
(X) - OFF

3-2 Beep Sound

| | |
|--|---|
| Power on (as soon as power button pressed) | So(0.3s) |
| Power on (lamp lighting failed) | 2 x {So(0.1s) – Off(0.1s)} per lighting failure 12s interval for each trial lighting. Max 4 times of trial |
| Power on (lens cap was not opened, for the model with sliding lens cover only) | 2 x {So(0.1s) – Off(0.1s)} periodically per 3 seconds, Totally 5 cycles. Turn off projector after 5 cycles. |
| Close lens cap while projector is operating (for the model with sliding lens cover only) | 2 x {So(0.1s) – Off(0.1s)} periodically per 3 seconds, Totally 5 cycles. Turn off projector after 5 cycles. |
| Power off (power button pressed twice) | So(0.3s) |
| Fan lock | So(0.1s) periodically per second |
| Overheat | 2 x {So(0.1s) – Off(0.1s)} periodically per second |
| Lamp error | 3 x {So(0.1s) – Off(0.1s)} periodically per second |
| Lamp Life reminding | 3 x {Do(0.2s) – Off(0.8s) – So(0.2s) – Off(0.8s)} with reminding message |
| Presentation Timer (time is up) | 3 x {Do(0.1s) – Off(0.9s)} - So(0.5s) |

3-3 Main Procedure

| No | Symptom | Procedure |
|----|----------------|--|
| 1 | No Power | <ul style="list-style-type: none"> • Ensure the Power Cord and AC Power Outlet are securely connected • Check Lamp Cover and Interrupt Switch • Ensure all connectors are securely connected and aren't broken • Check Lamp Driver • Check LVPS • Check Main Board |
| 2 | Auto Shut Down | <ul style="list-style-type: none"> • Check LED Status <ul style="list-style-type: none"> a. Power LED on(B/R), Lamp LED off, Temp LED on (R) <ul style="list-style-type: none"> • Check Thermal Switch • Check Fan b. Power LED on(B/R), Lamp LED on (R), Temp LED off <ul style="list-style-type: none"> • Check Lamp • Check Lamp Driver • Check Main Board c. Power LED on(B/R), Lamp LED off, Temp LED flash (R) <ul style="list-style-type: none"> • Check Fan • Check Main Board d. Power LED on(B/R), Lamp LED flash (R), Temp LED off <ul style="list-style-type: none"> • Check Color Wheel • Check Photo Sensor Board |

| No | Symptom | Procedure |
|----|----------------------|--|
| 3 | No Image | <ul style="list-style-type: none"> • Ensure the Signal Cable and Source work (If you connect multiple sources at the same time, use the “Source” button on the control panel to switch) • Ensure all connectors are securely connected and aren’t broken • Check Main Board • Check DMD Board • Check Colour Wheel • Check DMD Chip • Check Engine Module |
| 4 | No Light On | <ul style="list-style-type: none"> • Ensure all connectors are securely connected and aren’t broken • Check Lamp Module • Check Lamp Driver • Check LVPS • Check Main Board |
| 5 | Mechanical Noise | <ul style="list-style-type: none"> • Check Colour Wheel • Check Fan Module |
| 6 | Line Bar/Line Defect | <ul style="list-style-type: none"> • Check if the Main Board and the DMD Board are assembled properly • Check Main Board • Check DMD Board • Check DMD Chip |

| No | Symptom | Procedure |
|----|---|---|
| 7 | Image Flicker | <ul style="list-style-type: none"> • Do "Reset (All data)" of the OSD Menu • Ensure that the signal cables and source are work as well- Check Lamp Module • Check Colour Wheel • Check DMD Board • Check Main Board |
| 8 | Colour Abnormal | <ul style="list-style-type: none"> • Do "Reset (All data)" of the OSD Menu • Adjust Colour Wheel Index • Check Main Board • Check DMD Board • Check Colour Wheel |
| 9 | Poor Uniformity/ Shadow | <ul style="list-style-type: none"> • Ensure the projection screen without dirt • Ensure the projection lens is clean • Ensure the Brightness is within spec • Check rod alignment • Check Engine Module |
| 10 | Dead Pixel/Dust (Out of spec.) | <ul style="list-style-type: none"> • Ensure the projection screen without dirt • Ensure the projection lens is clean • Check DMD Chip and Engine Module • Check DMD Chip • Check Engine Module |
| 11 | Garbage Image | <ul style="list-style-type: none"> • Ensure that the signal cables and source work as well. • Check Main Board • Check DMD Board |
| 12 | Remote Control/ Control Panel Failed | <ul style="list-style-type: none"> • Remote Control <ul style="list-style-type: none"> a. Check Battery b. Check Remote Controller c. IR Sensor Board d. Check Main Board • Control Panel <ul style="list-style-type: none"> a. Check FPC b. Check key pad c. Check Main Board |

| No | Symptom | Procedure |
|----|---|---|
| 13 | Function Abnormal | <ul style="list-style-type: none"> • Do "Reset (All data)" of the OSD Menu • Check Main Board • Check DMD Board |
| 14 | Audio Abnonrmal | <ul style="list-style-type: none"> • Ensure that the signal cables and source are work as well • Check Speaker Module • Check Main Board |
| 15 | FW Upgrade Failed | <ul style="list-style-type: none"> • Ensure that the signal cables and PC are work as well • Check the software program version • Check the firmware file • Check the upgrade process • Check Main Board |
| 16 | Forgetting Password (adminstrator Password) | <ul style="list-style-type: none"> • Security Card. This unique password is a back door of Administrator Password which will be accepted by projector anytime no matter what the Administrator Password is. • How to get the Universal Password? <ol style="list-style-type: none"> (1) Click the "AcerSNID" <div data-bbox="794 1003 1056 1093" data-label="Image"> </div> (2) Input SNID number.(SNID number is on the Security Card) <div data-bbox="764 1234 1011 1462" data-label="Image"> </div> (3) Click "Calculate".Then the Universal Password will appear. <div data-bbox="767 1621 1086 1910" data-label="Image"> </div> |

| No | Symptom | Procedure |
|----|---|--|
| 17 | SD Card/ USB flash disk Function Failed | <ul style="list-style-type: none">• Ensure that the signal cables and source work as well.• Check Main Board• Check Daughter Board |

Function Test & Alignment Procedure

4-1 Test Equipment Needed

- IBM PC with SVGA/XGA resolution
- DVD player with Multi-system (NTSC/PAL/SECAM), equipped "Component", "S-Video", "Composite" and "HDMI".
- HDTV Source (480P, 720P, 1080i)
- Minolta CL-100
- Quantum Data 802B or CHROMA2327 (Color Video Signal & Pattern Generator)
- After changing parts, check the information below.

4-2 Service Mode

1. Turn on the projector and input the signal
2. Do the following actions sequentially to enter service mode menu
 - (1) Press "Power→Left→Left→Menu".
 - (2) Service mode will be shown.
 - (3) After confirming the configuration, press "Exit" to exit.

4-3 OSD Reset

1. After final QC step, we have to erase all saved change again and restore the OSD default setting. The following actions will allow you to erase all end-users' settings and restore the default setting:
 - (1) Please enter OSD menu.
 - (2) To execute "Reset" function.

4-4 Test Condition

- Circumstance brightness: Dark room less than 5.0 lux.
 - Inspection distance: 1.8m~2.5m functional inspection.
 - Screen size: 60 inches diagonal
 - After repairing each P3150/P3250/P3150 refresh/P3250 refresh/P3251
- , the unit should be run-in (refer to the table below)

| Symptom | Run-in Time |
|----------------|-------------|
| Normal repair | 2 hours |
| NFF | 4 hours |
| Auto shut down | 6 hours |

- Enter Burn-In Mode

* Cycle setting is based on the defect symptoms. ie: If it is NFF, the run-in time is 4 hours. You have to set the lamp on for 50 min. and lamp off for 10 min for 4 cycles.

| | |
|--|---|
| Press Power > Left > Left > Menu | |
| Choose Burn-In Test > enter | |
| Lamp On (Min) | Press right key to adjust the time (50) |
| Lamp Off (Min) | Press right key to adjust the time (10) |
| Set burn in cycle | Press right key to adjust the cycle |
| After setting up the time, choose Burn-In mode and hit enter | |

Screen Defects (While replacing DMD Chip, DMD BD and MB)

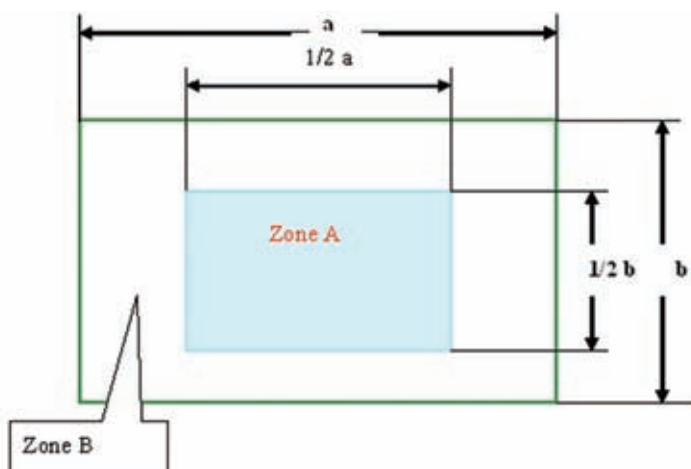

< Figure: Zone A & B Definition >

Defect specification table

| Order | Symptom | Pattern | Criteria |
|-------|---------------------|-----------------------|---------------|
| 1 | Bright pixel (dots) | Gray 10 pattern | $A+B \leq 1$ |
| 2 | Dark pixel (dots) | White pattern | $A+B \leq 6$ |
| 3 | Bright blemish | Gray 15 pattern | $A+B \leq 10$ |
| 4 | Dark blemish | Blue 60 pattern | $A+B \leq 10$ |
| 5 | Bright dot on frame | Gray 10 pattern | ≤ 1 |
| 6 | Unstable pixel | White & Black pattern | $A+B \leq 1$ |
| 7 | Adjacent dark pixel | White & Black pattern | $A+B = 0$ |

4-5 Test Inspection Procedure

| Change parts/ Update | M/B | FW | Color Wheel | Lamp Module | Engine | EDID | Lamp Driver |
|---|-----|----|----------------|----------------|--------|------|----------------|
| Version Update | v | v | | | | v | |
| Color Wheel Index | v | | v | | | | |
| Reset lamp hour | | | | v | | | |
| OSD Reset | v | v | | | | | |
| EDID | v | | | | | | |
| Re-write Lamp Hour Usage | v | | | | | | |
| Check ROD Position and Adjust | | | | | v | | |
| Reset Dafult Language (for refresh models/ P3251) | v | v | | | | v | |
| Waveform Download (for refresh models) | v | v | | | | | v |

4-6 PC MODE

NOTE: Test Signal: analog 800x600 @60Hz(P3150/P3150 refresh), analog 1024x768 @60Hz(P3250/P3250 refresh/P3251). Take P3250 for example.

1. Frequency and tracking boundry

Procedure

- Test equipment: video generator.
- Test signal: analog 1024 x 768@60Hz
Partern: general-1 or master
- Check and see if the image sharpness is well-performed.
- If not re-adjust by the following steps:
 - (1) Select "Frequency" to adjust pixel number of pixel clock in one line period.
 - (2) Select "Tracking" and use right or left arrow key to a value to minimize video flicker.

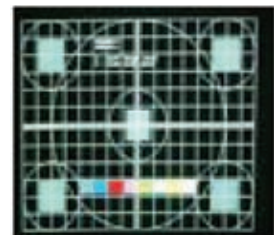

General-1



Master

| | |
|-----------------|---|
| Inspection item | <ul style="list-style-type: none"> - Adjust Resync or Frequency/Tracking/H. Position/V. Position to the inner screen. - Eliminate visul wavy noise by Rsync, Frequency or Tracking selction. - Check if there is noise on the screen. - Horizontal and vertical position of the vedio should be adjustable to the screen frame. |
| Criteria | <ul style="list-style-type: none"> - If there is noise on the screen, the product is considered as failure product. - If there is noise on the screen, use auto or manual "frequency" function or "tracking" function to adjust the screen. - The PC mode functionally sure be workable include support format with frequency and auto detected functional will be workable. |

2. Bright Pixel

| | |
|-----------------|---|
| Procedure | <ul style="list-style-type: none"> - Test equipment: video generator - Test signal: analog 1024 x 768@60Hz - Test Pattern: Gray 10 |
| Inspection item | <ul style="list-style-type: none"> - Bright pixel check. |
| Criteria | <ul style="list-style-type: none"> - Bright pixel should be no more than 1 under gray 10 pattern. - Adjacent pixels are unacceptable. - Ref. Defect specification table. |

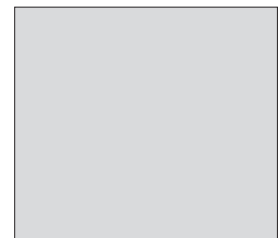

Gray 10

3. Dark Pixel

| | |
|-----------------|--|
| Procedure | <ul style="list-style-type: none"> - Test equipment: video generator - Test signal: analog 1024 x 768@60Hz - Test Pattern: Full white |
| Inspection item | <ul style="list-style-type: none"> - Dark pixels check. |
| Criteria | <ul style="list-style-type: none"> - The dark pixel should be no more than 6 under full white pattern. - Adjacent pixels are unacceptable. - Ref. Defect specification table. |



Full white

4. Bright Blemish

- Procedure
- Test equipment: video generator
 - Test signal: analog 1024 x 768@60Hz
 - Test Pattern: Gray 15
- Inspection item
- Bright blemish check.
- Criteria
- The bright blemish should be no more than 10 under gray 15 pattern.
 - Ref. Defect specification table.

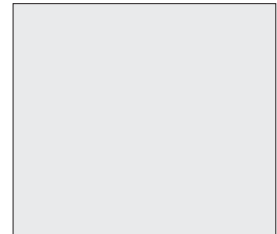

Gray 15

5. Dark Blemish

- Procedure
- Test equipment: video generator.
 - Test signal: analog 1024x768@60Hz.
 - Test Pattern: Blue 60
- Inspection item
- Dark blemish check.
- Criteria
- The dark blemish should be no more than 10 under blue 60 pattern.
 - Ref. Defect specification table



Blue 60

6. Focus test

- Procedure
- Test equipment: video generator.
 - Test signal: analog 1024 x 768@60Hz
 - Test Pattern: Full screen
- Inspection item
- Focus check
- Criteria
- From screen 2 M via visual to check the focus, look at the entire screen, focus shall be clear, crisp, and sharp over the entire surface of the display pattern. (Blur word on one of the corner after adjustment is acceptable. However, the word should at least be recognizable.)

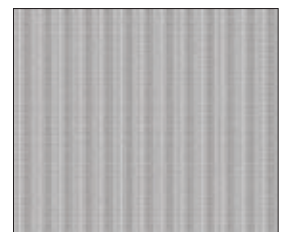

Full screen

7. Color performance

| | |
|-----------------|---|
| Procedure | <ul style="list-style-type: none"> - Test equipment: video generator. - Test signal: 480p, 720p, 1080p - Test Pattern: Master, 64 gray RGBW or SMPTE bar <p>* Please refer to 4-2 to get into service mode. Use 720p & 1080p signal, master pattern to do HDTV test. Color cannot discolor to purple and blue.</p> |
| Inspection item | <ul style="list-style-type: none"> - Check if each color level is well-functioned. - Color saturation |
| Criteria | <ul style="list-style-type: none"> - Screen appears normal. It should not have any abnormal condition, such as lines appear on the screen and so on. - Color appears normal. - It is unacceptable to have few lines flashing. - RGBW should all appear normal on the screen and sort from R -G-B-W. - Color levels should be sufficient and normal. (The unidentified color levels on both left and right sides should not over 4 color levels.) - Gray level should not have abnormal color or heavy lines. - If color appears abnormal, please get into service mode to do color wheel index adjustment. |

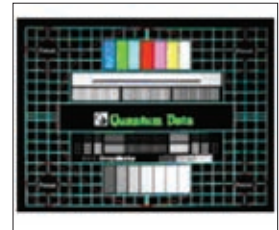

Master



64 gray RGBW

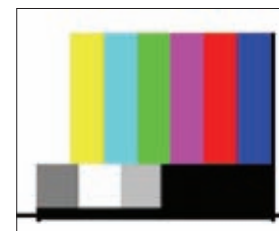

SMPTE BAR

4-7 Video Performance

1. CVBS

| | |
|---------------------|--|
| Procedure | <ul style="list-style-type: none"> - Test equipment: DVD player - Test signal: CVBS |
| Inspection item | <ul style="list-style-type: none"> - Video performance test |
| Inspection Distance | <ul style="list-style-type: none"> - 1.8M ~2.5M |
| Criteria | <ul style="list-style-type: none"> - Check any abnormal color, line distortion or any noise on the screen. |



SMPTE RP-133

- Check the sound from speakers.

2. S-Video

- Procedure
- Test equipment: DVD player
 - Test signal: S-Video
- Inspection item
- Video performance test
- Inspection Distance
- 1.8M ~2.5M
- Criteria
- Check any abnormal color, line distortion or any noise on the screen.
 - Check the sound from speakers.

3. HDTV/ Component

- Procedure
- Test equipment: DVD player
 - Test signal: Ycbcr/YPbPr
- Inspection item
- HDTV performance test
- Inspection Distance
- 1.8M ~2.5M
- Criteria
- Check any abnormal color, line distortion or any noise on the screen.
 - Check the sound from speakers.



Motion video

4. Audio Test

- Procedure
- Test equipment: DVD player
 - Test signal: CVBS
- Inspection item
- Audio performance test
- Inspection Distance
- 1.8M ~2.5M
- Criteria
- Check the sound from speakers.
 - Check "Volume" is normal
 - Check "Mute" is normal

5.HDMI Test

| | |
|-----------------|---|
| Procedure | <ul style="list-style-type: none">- Test Signal : 720p,1080i- Test Pattern : Any Pattern- Equipment: DVD Player with HDMI output- Display type must be set to 16:9 |
| Inspection item | <ul style="list-style-type: none">- HDMI Test |
| Criteria | <ul style="list-style-type: none">- Ensure if the image is well performed and the color can not discolor. |

4-8 Optical Performance Measure

| Inspection Condition |
|--|
| <ul style="list-style-type: none">- Environment luminance: 5 Lux- Product must be warmed up for 3 minutes- Distances from the screen: 2.36 M- Screen Size: 60 inches diagonal- Reset to default before measurement |

1. Test equipment

| | |
|-----------|---|
| Procedure | <ul style="list-style-type: none">- Press "Power→Left→Left→Menu".- Select "Spoke Test" |
|-----------|---|

2. Brightness

- Procedure
- Full white pattern
 - Use CL100 to measure brightness values of P1~P9.
 - Follow the brightness formula to calculate brightness values.
- ☀ Brightness Formula
- $$\text{Avg.}(P1 \sim P9) \times 1.1 \text{m}^2$$
- Criteria
- 900 lumens

3. Full On/Full Off Contrast

- Procedure
- Full white pattern & full black pattern
 - Use CL100 to measure brightness values of full white pattern P5 & full black pattern B5 (see image: full white)
 - Follow Contrast formula to calculate contrast values.
- ☀ Contrast Formula
- $$P5/B5$$
- Note: P5=center of white image
B5=center of black image.
- Criteria
- 1400:1

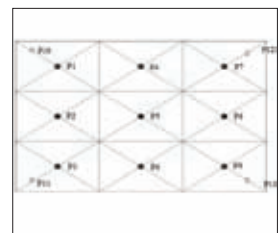

Full white pattern

4. Uniformity

- Procedure
- Full white pattern
 - Use CL100 to measure brightness values of P1~P9 (see image: full white).
 - Follow the Uniformity formula to calculate average values.
- ☀ Uniformity Formula
- $$\text{ANSI Uniformity} = \frac{\text{Avg.}(P1, P3, P7, P9)}{P5} \times 100\%$$
- Criteria
- 65%



Full black pattern

4-9 SD Card /USB flash disk Test (only for P3251)

1.SD Card Test

- Procedure
- Test equipment: SD Card(include test pattern),
 - Test Pattern: WhiteBlack,Graystep16, ColorBar
 - Turn on the projector and plug SD Card into the projector.
 - Select “SD”-->”Photo”, play the test pattern in SD Card.
 - Press “2” button on remote controller when play the WhiteBlack test pattern.
 - Get into service mode (Please refer to 4-2).
 - Select “Analog Settings”-->”MMS Calibration”
 - “Success” will appear on MMS Calibration.
 - Press”2” button on remote controller to play the test pattern.



WhiteBlack_640x480

- Inspection item
- Check if each color level is well-functioned.
 - Color saturation
- Criteria
- Screen appears normal. It should not have any abnormal condition, such as lines appear on the screen and so on.
 - Color appears normal.
 - It is unacceptable to have few lines flashing.

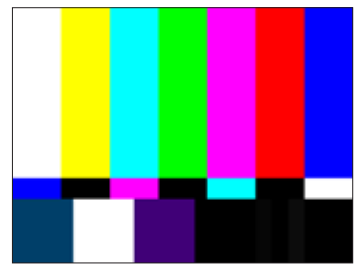

ColorBar_640x480

2. USB flash disk Test

- Procedure
- Test equipment: USB flash disk(include video file)
 - Test Pattern: video file.
 - Turn on the projector and plug USB flash disk into the projector.
 - Select “USB”-->”Video”, play video file in USB flash disk.

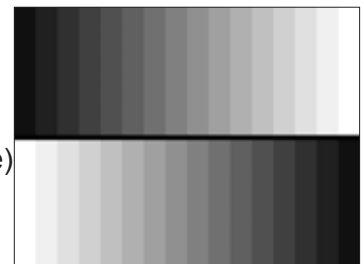

GrayStep16_640x480

- Inspection item
- Check any abnormal color, line distortion or any noise on the screen.
 - Check the sound from speaker.
- Criteria
- Screen and sound appears normal.

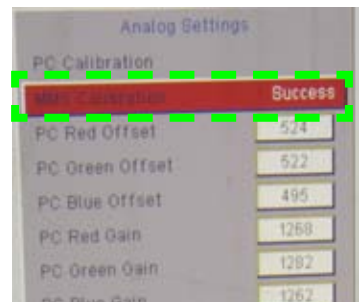

4-10 Others

1. Functional Inspection

- Keypad button - All keypad buttons must operate smoothly.
- General - All OSD functions must be checked for functionality. When OSD menu is displayed, there shall be no visible peaking, ringing, streaking, or smearing artifacts on the screen.
- Factory Default - The factory settings (with appropriate centering, size, geometry distortion, etc.) shall be displayed upon "Recall" is selected from OSD
- Display Size - All preset modes shall expand to full screen size using OSD Horizontal and Vertical Size controls
- Display Data Channel (DDC) - The purpose of the DDC test is to verify the DDC1/DDC2B operation of the projector and to verify Plug & Play function.
- Acoustic - High pitch sound from cooling fan and color wheel is unacceptable.

2. Check points for exterior and print pattern

| Check item | Check point |
|-------------------------|---|
| Text & Pattern | Missing letters & pattern or blurry prints are unacceptable. |
| Exterior | Dirt, scrape, water ripples and uneven color are unacceptable. |
| Buttons | Stuck buttons are unacceptable. |
| Focus ring | Focus ring is functioning smoothly. |
| Logo | Missing logo, missing prints and blurry prints are unacceptable |
| Screw | All screw sure be fixed and in right type. |
| Pedestal | Well-functioned |
| Lamp Cover | It should be locked in the correct place. |
| Plastic Parts | All plastic parts can not be brocken and damaged. |
| Safety or warning label | All safety and warning label should be visible, including all contents. |
| Connector | All interface connector should be complete and workable. |

Firmware Upgrade

Section 1: System Firmware Upgrade

5-1 Equipment Needed

Software :

- DLP Composer
- Firmware
- 8M Flash (8M flash has to put in PC and set right path in 5-5 step4)

Hardware :

- Projector
- Power cord (42.53506G002)
- USB Cable (42.87304G001)
- PC or Laptop

Note: The FW upgrade procedure for P3150/P3250/P3150refresh/P3250 refresh/P3251 is the same. Here, we take P3250 as an example.



5-2 DLP Composer Lite Setup Procedure

1. Choose "DLP Composer Lite V7.1 Setup" Program.
2. Click Next button.
3. Read License Agreement.
 - Choose I accept and agree to be bound by all the terms and conditions of this License Agreement.
4. Click Next.
5. Click "Next".

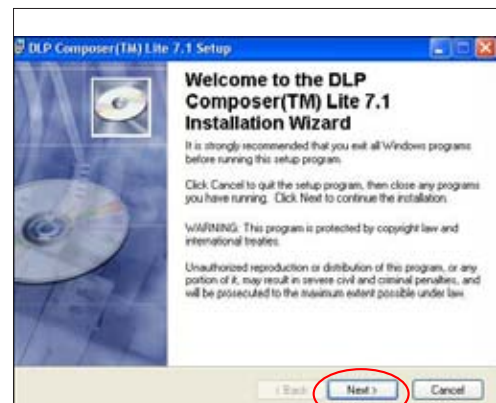

6. Click Next.

7. Click Next.

8. Writing system registry values.

9. Click Finish.

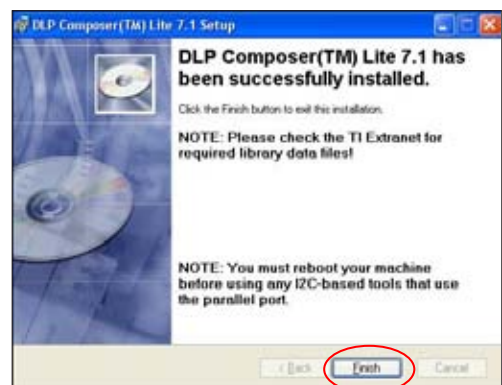
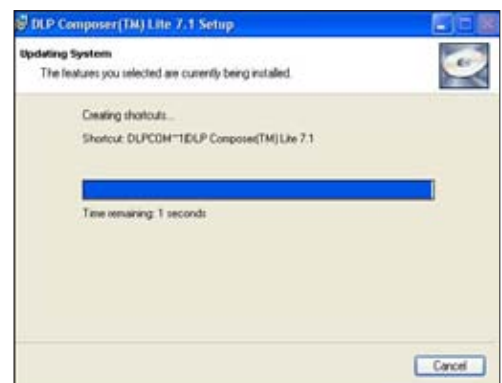
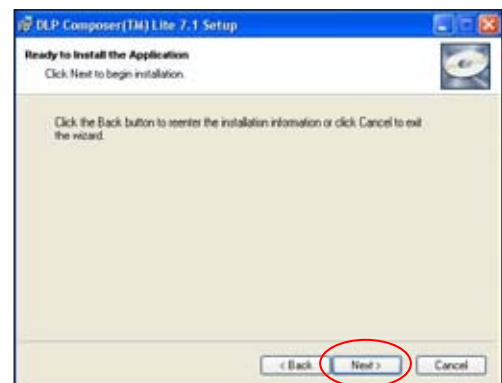
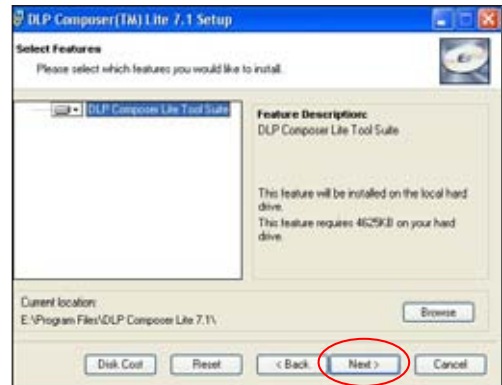

5-3 USB Driver Upgrade Procedure

1. Set up

- Plug in power cord and then press "Power" and "Menu" button simultaneously hold on about 5 seconds, release "Power" and "Menu" button
- Once the Power ,Lamp and Temp LED light on RED at the same time, plug in USB cable into the projector and link to the USB port of a PC.

2. Execute Program

- Found new hardware wizard will be appeared on the screen.
- Select Install the software automatically (Recommended).
- Then click Next.



3. Finish

- Click Finish to end the installation.



5-4 Firmware Upgrade Procedure

1. Set-up

- Plug in power cord and then press "Power" and "Menu" button simultaneously hold on about 5 seconds, release "Power" and "Menu" button
- Once the Power ,Lamp and Temp LED light on RED at the same time, plug in USB cable into the projector and link to the USB port of a PC.



2. Execute the DLP Compose™ file.

3. Click edit and preferences.

4. Click "Library."

- Click the "browse" button and navigate to the directory where you put the library file in.

Note: P3251's library need to use the library in "DLP Composer Lite v9.2" .

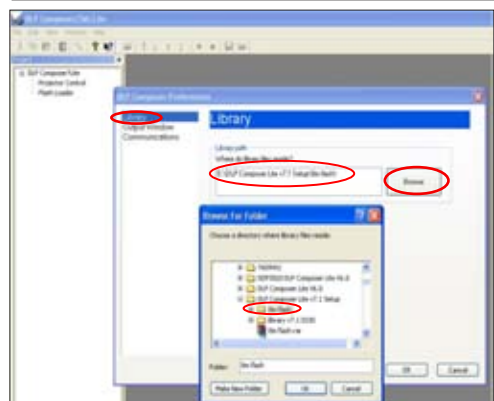
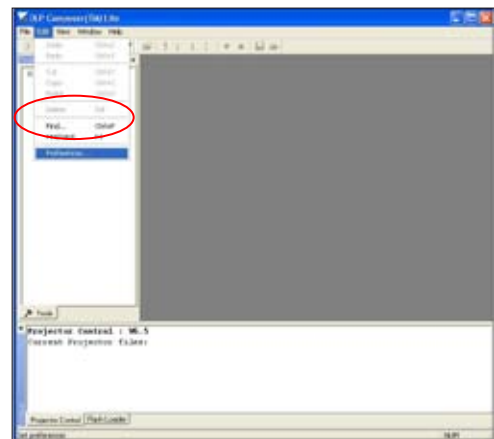

5. Select Edit\preferences\Communications

- Choose USB".

- Click OK".

6. Choose Flash Loader.

- Click Browse to search the firmware file.

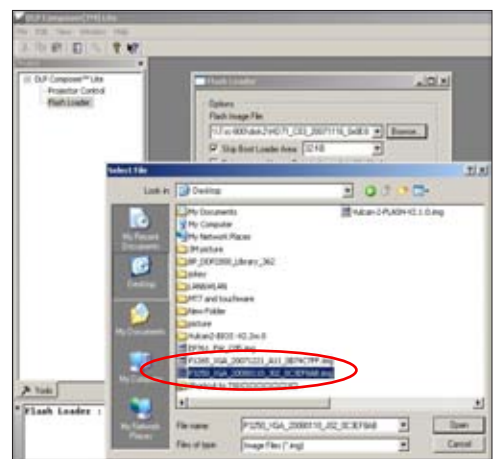
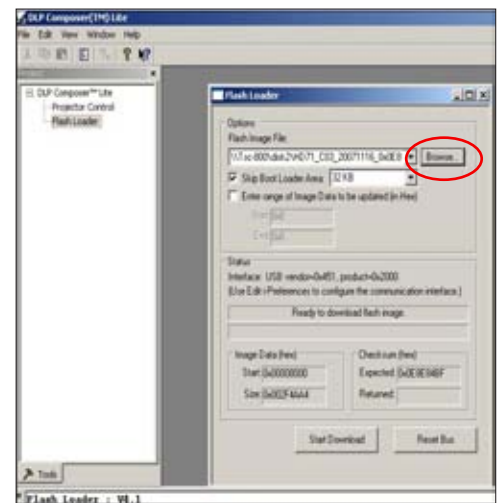
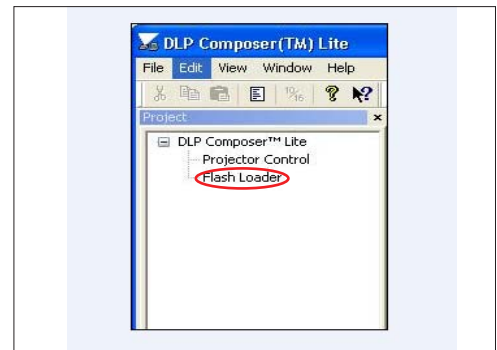
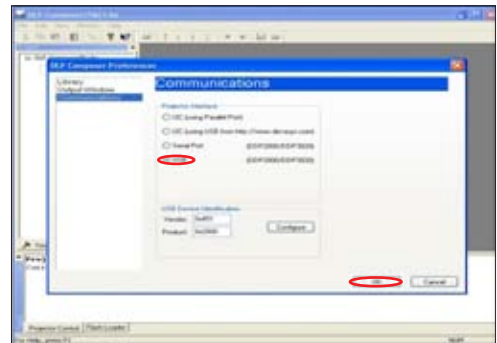

7. Selete the item skip Boot Loader Area (select 32KB).

- Click Reset Bus to erase the flash memory.

8. If the firmware is ready, click start download to process the firmware upgrade.

- Click Yes to erase the flash memory.

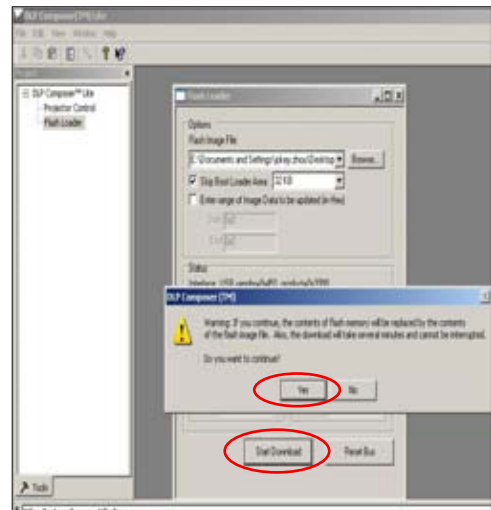
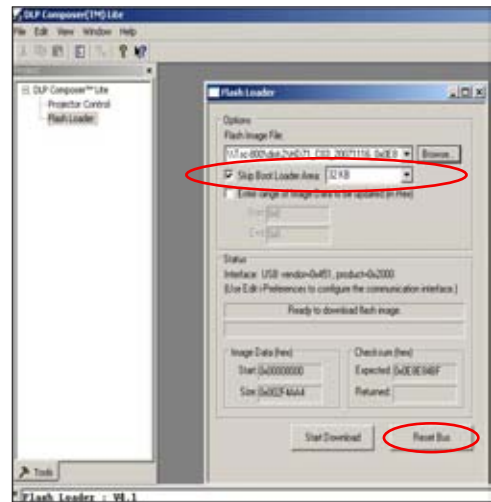

9. When firmware upgrade process is finished the unit return to stand-by status. The Power LED lights on Red.

- Unplug USB cable and power cord and replug in power cord.

10. Restart the unit and enter the service mode to check the firmware version. (To enter service mode, please refer to Chapter 4 Function Test and Alignment Procedure.)

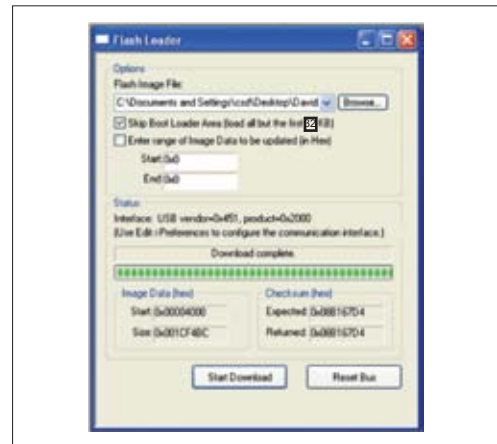

Section 2 : Waveform Download

5-5 Waveform Download (for refresh models)

1. Hold on the “Up” button, then plug Power Cord in, the Power LED lights on red. After about 5 seconds release “Up” button, Power LED turns to blue and Temp LED will flash for 4 seconds. After that, Temp LED and Lamp LED light on red, and Power LED lights blue.
2. Re-plug in power cord and turn on this projector. If the image is steady, the process is ok!

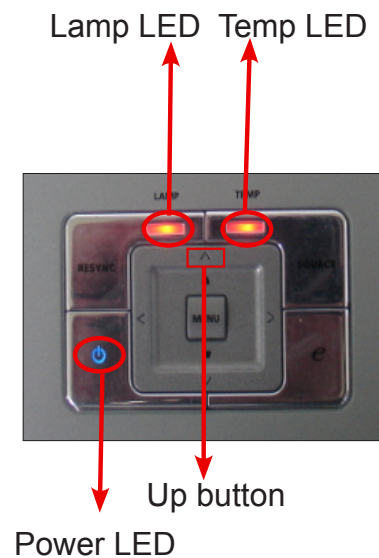

*Note: This step must be executed after FW,
Main Board or Lamp Driver changed*

5-6 Waveform Download (for P3251)

1. Hold on the "Power" button, then plug Power Cord in, After about 4 seconds, release "Power" button, at the same time the Lamp LED flash red.
2. After about 10 seconds, Power LED lights red, the message means success download.
3. Re-plug in power cord and turn on this projector. If the image is steady, the process is ok!

*Note: This step must be executed after FW,
Main Board or Lamp Driver changed*

Section 3 : Multi-Media Firmware Upgrade (only for P3251)

5-7 Equipment Needed

Software :

- 1201 tool
- Firmware (*.fwu)

Hardware :

- Projector
- Power cord (42.53506G002)
- USB Cable (male to male)
- PC or Laptop



5-8 USB Driver Upgrade Procedure

1. Set up

- Hold on "Power" and "Menu" button and then Plug in power cord , hold on about 5 seconds, release "Power" and "Menu" button , the Power Lamp and Temp LED light RED at the same time.
- Plug in USB cable into the projector and link to the USB port of a PC.

2. Execute Program

- 1) Found new hardware wizard will be appeared on the screen.
 - Select "Install from a list or specific location (Advanced)"
 - Then click Next.
- 2) - Click "Browse" button to choose "1201 tool"
 - Select "OK" ,
 - Then click Next.

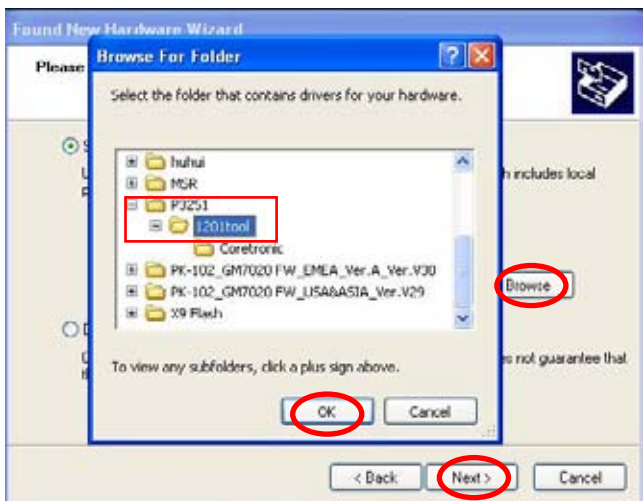

3) Click "Continue Anyway".



4) Click "Finish" to end the installation.



5) Found new USB Root HUB will be appeared on the screen.



4. Click "Download."

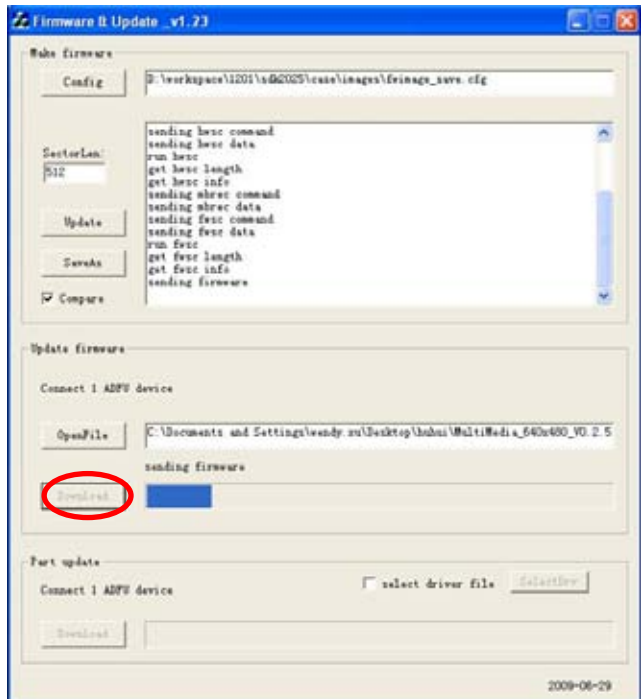

5. The success information will show on screen (as red square)

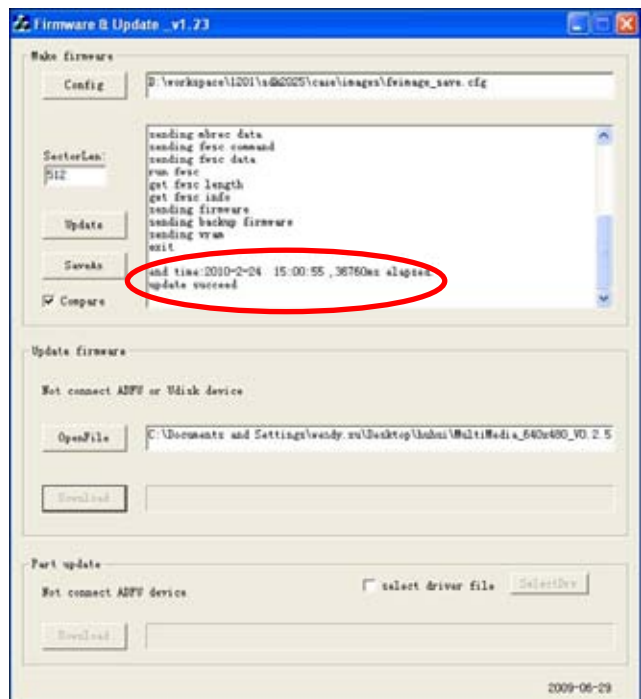

6. Restart the unit and enter the service mode to check the Multi-Media firmware version.

(To enter service mode, please refer to Chapter 4 Function Test and Alignment Procedure.)

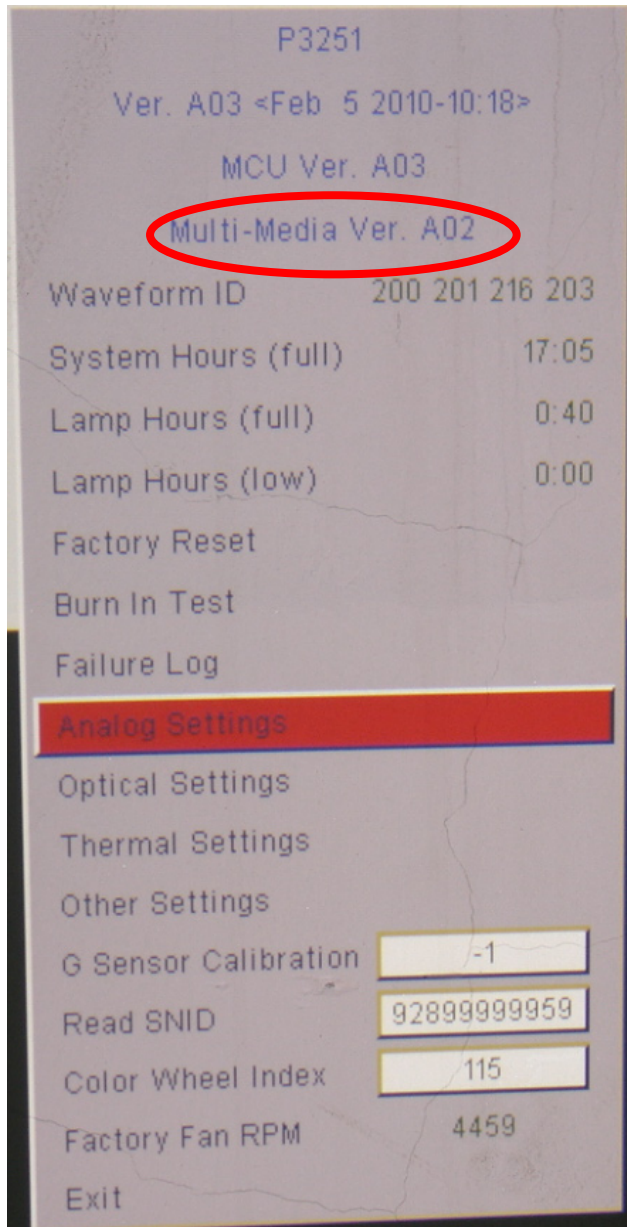

EDID Upgrade

6-1 EDID Introduction

Extended Display Identification Data is a VESA standard data format that contains basic information about a display device and its capabilities, including vendor information, maximum image size, color characteristics, factory pre-set timings, frequency range limits, and character strings for the monitor name and serial number.

The information is stored in the display and is used to communicate with the system through a Display Data Channel (DDC), which sits between the display device and the PC graphics adapter. The system uses this information for configuration purposes, so the monitor and system can work together.

Note: If a display device has digital input ports, like DVI or HDMI, but without EDID in its main board, the display device will show no image while the input source is digital signal. After EDID upgraded, do " default language reset"

6-2 Equipment Needed

Software

- EDID Program (Generic V0.51)
- EDID File

Hardware

- Projector
- Generic Fixture (80.00001.001) for EDID Key-in (Fixture: JP3 must be closed)
- Power cord for Projector (42.53506G002)
- RS-232 9 Pin Cable (pin to pin, F-M) (42.83C07G001)
- Monitor
- PC
- VGA cable (42.87305G102)
- DVI Cable (42.83N06G001)
- Power adapter (47.57803G001) and power cord (42.53506G002) for fixture
- Adapter HDMI(M) to DVI-D(F) (42.82B13G001)

Note: The EDID upgrade procedure for P3150/P3250/P3150 refresh/P3250 refresh/P3251 is the same. Here, we take P3250 as an example.

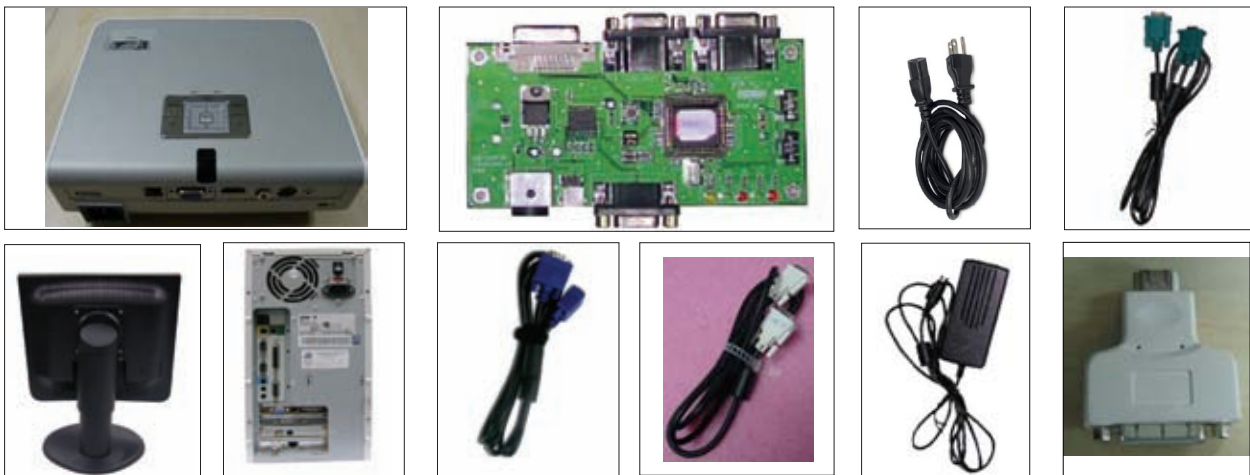

6-3 Setup Procedure (VGA)

1. Connect all ports

- (1) Connect P1 of Fixture with COM Port of PC/Laptop by RS232 Cable.
- (2) Connect P2 of Fixture with VGA port of Projector by VGA Cable.
- (3) Plug Power Adapter to Power CNN.
- (4) Plug Power Cord to P3250 unit.

Note: Confirm JP3 is Close status.

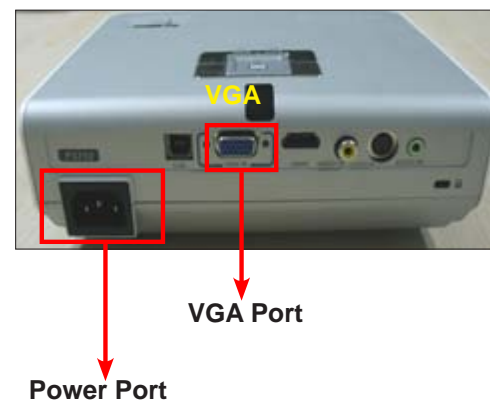
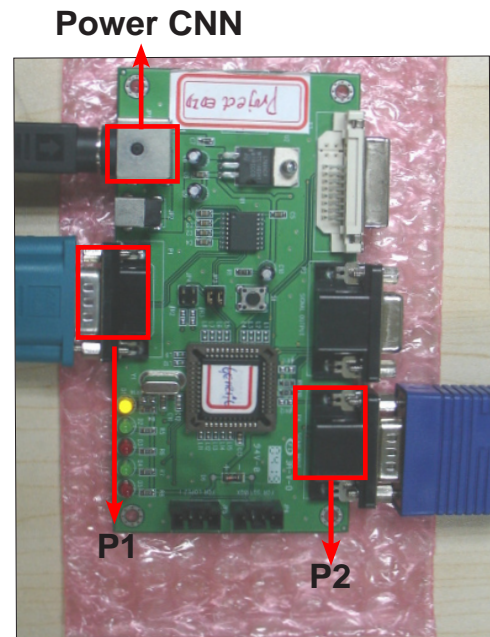

6-4 EDID Key-In Procedure

1. Execute EDID Program

- (1) Click on "EDID" to execute EDID program.

2. Process

- (1) Check the COM port is COM 1"
(Select the COM port which you are using).

- (2) Click the Model button.

- (3) Choose the source file
"ACER_P3250_20080218_C.ini"
and then open it.

3. Process

- (1) Key in the serial number into the barcode blank space.
- (2) In Write Source Select item, select Analog.
- (3) Click "Program" button.

4. Process

- (1) "Please change the cable to Analog" will be shown on the screen.
- (2) Please press "Ok" button.

1



2

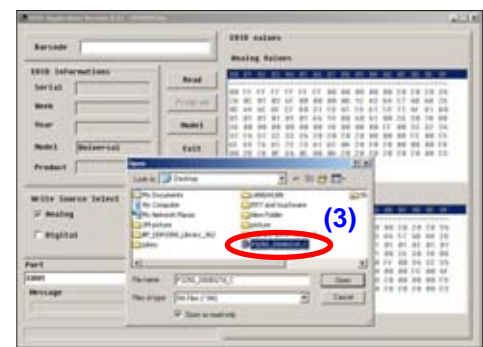
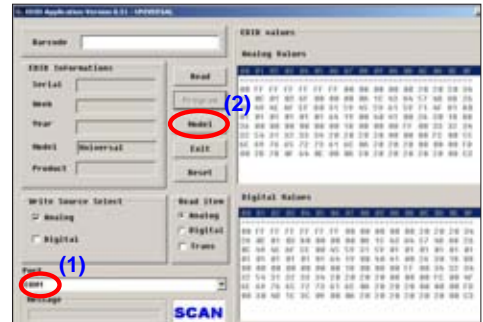

3

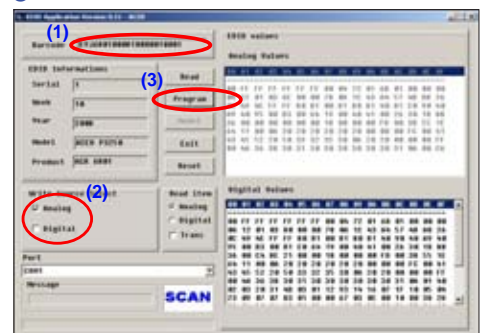

4

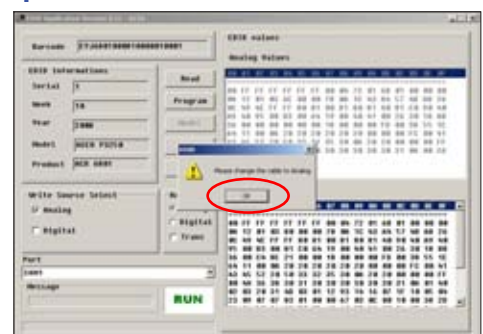

5. Finish

(1) "OK" will be shown on the screen.

6. Read EDID information

(1) In the Read item,select "Analog" and "Trans".

(2) Please press "Read" button.

7. Read EDID information

(1) EDID Informations will show the result.

5

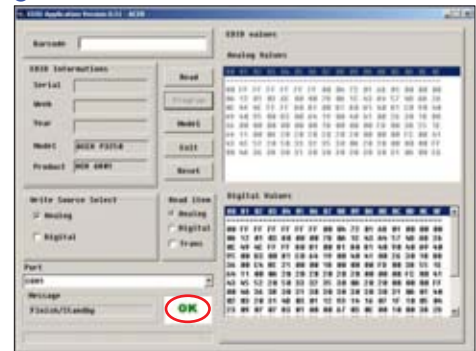

6

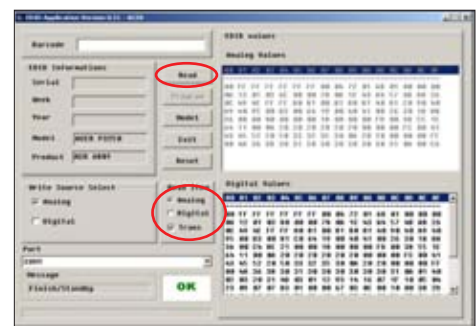

7

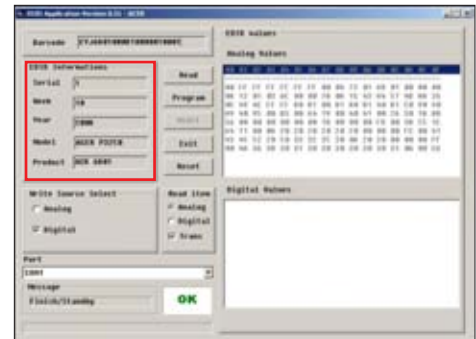

6-5 Setup Procedure (HDMI)

1. Connect all ports

- (1) Connect P1 of Fixture with COM Port of PC/Laptop by RS232 Cable.
- (2) Connect P2 of Fixture with P3 by DVI Cable.
- (3) Plug P4 to HDMI Port of the Projector.
- (4) Plug Power Adapter to Power CNN.
- (5) Plug Power Cord to P3250 unit.

Note: Confirm JP3 is Close status.



HDMI Port

Power Port

Power CNN

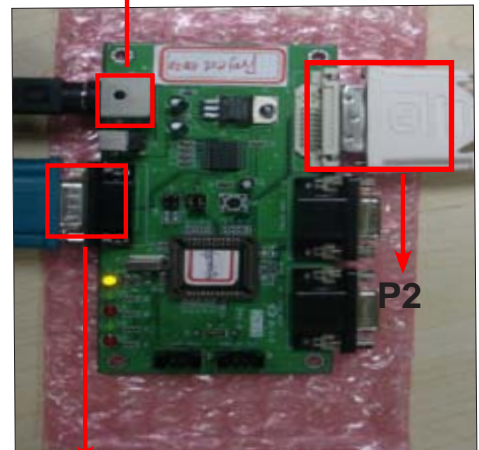

P1

P4

P2



P3

2. Process

- (1) Check the COM port is "COM 1"
(Select the COM port which you are using).
- (2) Click the "Model" button.
- (3) Choose the source file
"ACER_P3250_20080218_C.ini"
and then open it.

3. Process

- (1) Key in the serial number into the barcode blank space.
- (2) In "Write Source Select" item, select "Digital".

4. Process

- (1) "Please change the cable to Digital" will be shown on the screen.
- (2) Please press "Ok" button.

2

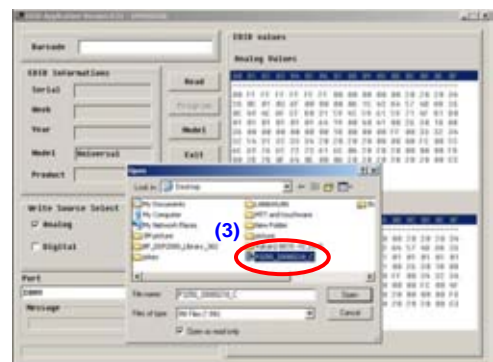
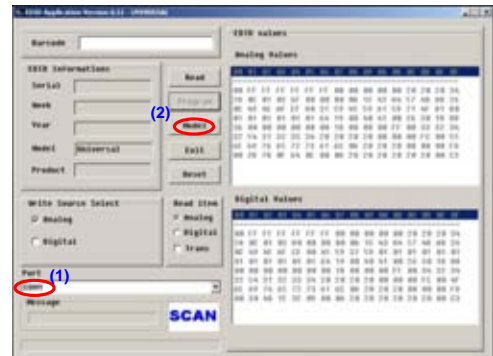

3

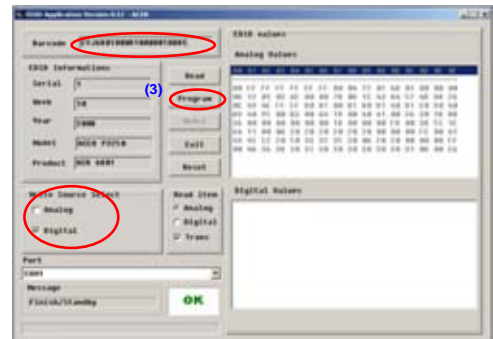

4

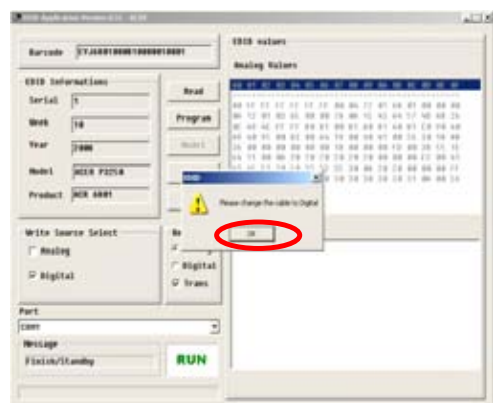

5. Finish

(1) "OK" will be shown on the screen.

6. Read EDID information

(1) In the Read item, select "Digital" and "Trans".

(2) Please press "Read" button.

7. Read EDID information

(1) EDID Informations will show the result.

5

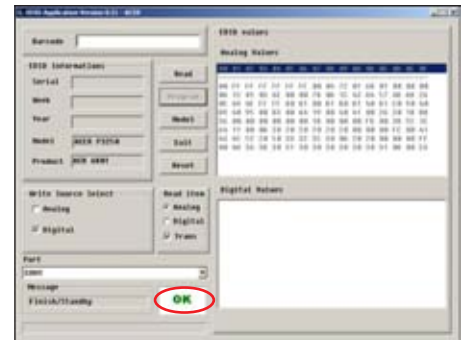

6

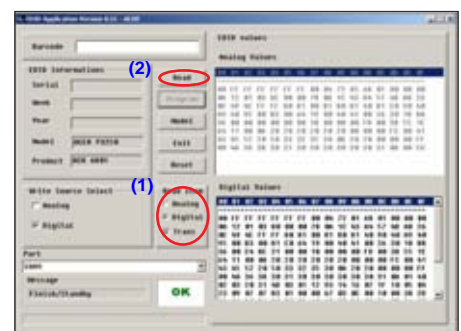

7

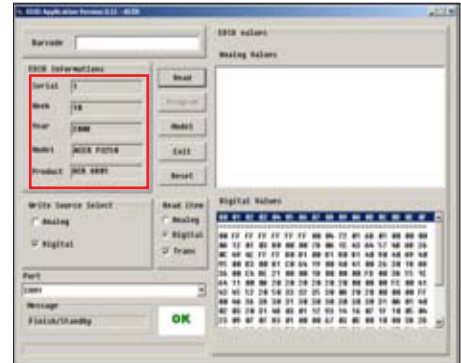

6-6 Default Language Reset (For P3150 refresh/P3250 refresh)

(1) Hold on “Down” button then plug in the Power Cord.

Note: At this moment, Power LED turns blue while Temp LED flashes in red for about 4s, then release the “Down” button.

(2) After that, please check the LED status and judge the actions as the following table:

| LED Status | Result |
|---------------------------------|--------|
| Power(blue)+TEMP(red)+LAMP(red) | OK |
| Power(blue)+TEMP(red) | Fail |

Note: if fail, please do the actions as above steps item (1)-(2)

S/N General rule



Use the last 1 digit code (as red word) for language information

| Language code(F) | Default Language |
|------------------|------------------|
| 1 | English |
| 2 | Thailand |
| 3 | Japan |
| 4 | TC |
| 5 | SC |
| 6 | Russian |
| 7 | Germany |
| 8 | Hungarian |

Appendix A

DC. P3150

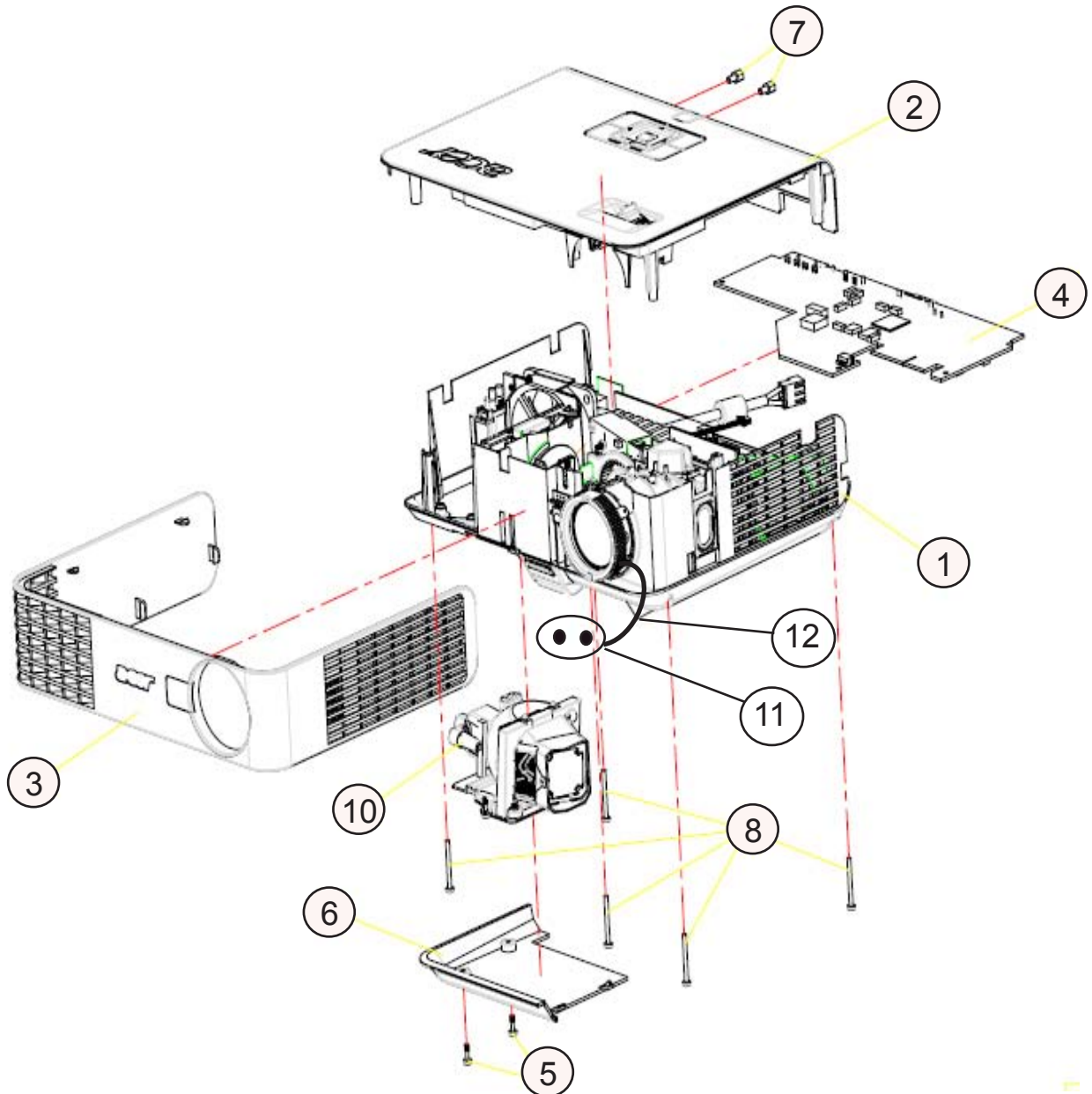

| ITEM | P/N | DESCRIPTION | Supply |
|------|--------------|---|--------|
| 1 | 70.89Y03G001 | ASSY BOTTOM COVER P3150 | N |
| 2 | 70.89Y01G001 | ASSY TOP COVER MODULE P3150 | N |
| 3 | 70.89Y02G001 | ASSY FRONT COVER P3150 | N |
| 4 | 70.89Y08G001 | ASSY MAIN BOARD MODULE P3150 | N |
| 5 | 61.85928G001 | LAMP HOUSING SHOULDER SCREW SB | N |
| 6 | 51.89Y02G002 | LAMP COVER P3150 | |
| 7 | 85.005AG040 | SCREW I/O STEEL #4-40UNC*H4*L5 | N |
| 8 | 85.1A326G250 | SCREW PAN MECH M2.6*25 BLACK | N |
| 9 | 51.00001G001 | CABLE TIE PG-YJ-80 | N |
| | SP.89Y01GC01 | LAMP MODULE FOR PROJECTOR P3150/ P3250 | |
| 10 | 70.89Y14G001 | ASSY LAMP MODULE P3150 | N |
| 11 | 52.89Y04G002 | LENS-CAP FOR P3150 | |
| 12 | 51.89Y16G001 | LENS CAP STRAP P3150 | |

ASSY BLOWER 4510 MODULE

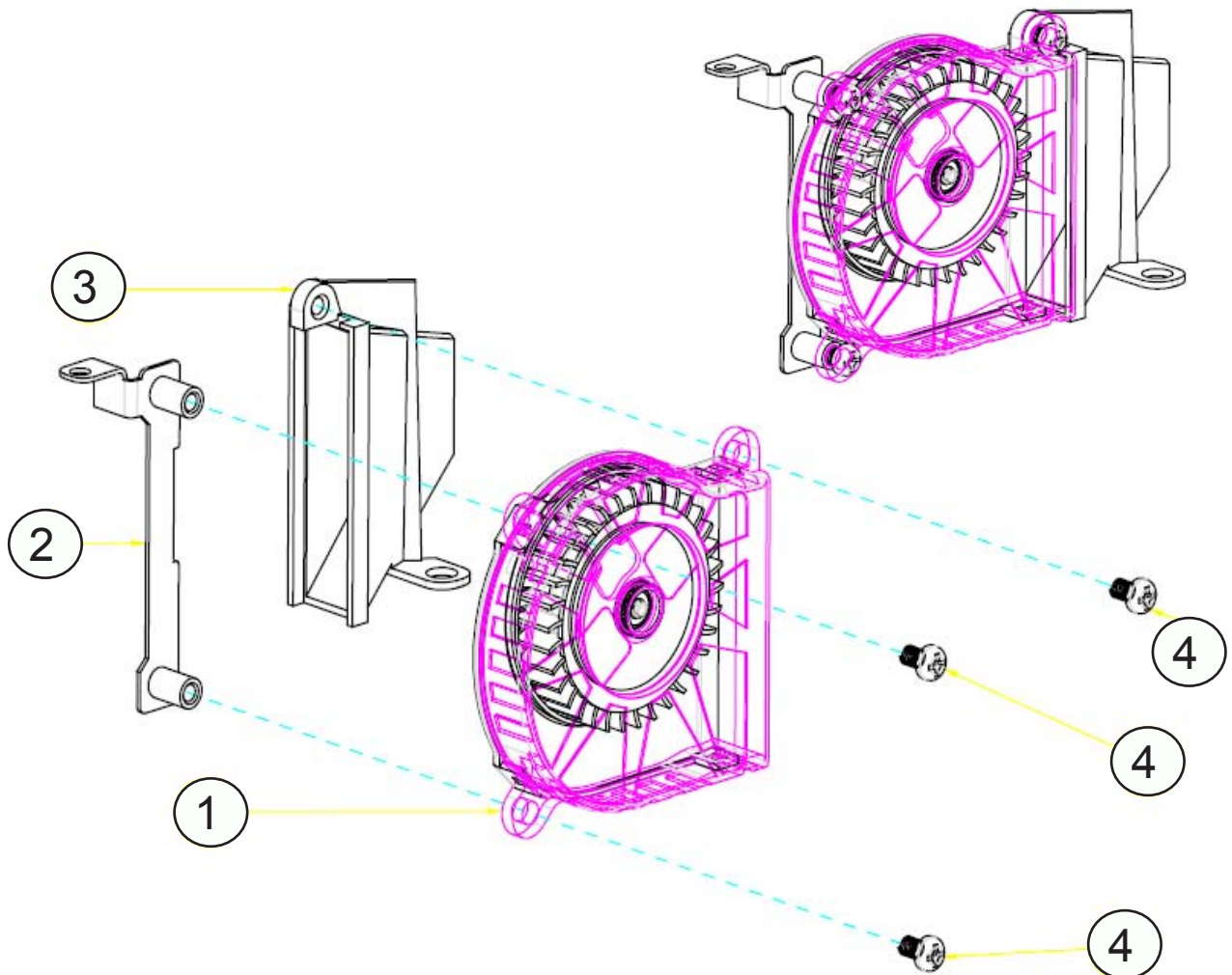

| ITEM | P/N | DESCRIPTION | Supply |
|------|--------------|--------------------------------|--------|
| 1 | 49.89S01G001 | LAMP BLOWER / 45*45*10 mm, 60m | |
| 2 | 61.89S13G001 | BLOWER 4510 HOLDER SECC M209X | N |
| 3 | 61.89S11G001 | LAMP BLOWER 4510 DUCT AL M209X | N |
| 4 | 85.1A126G040 | SCREW PAN MECH M2.6*4 Ni | N |

ASSY TOP COVER MODULE P3150

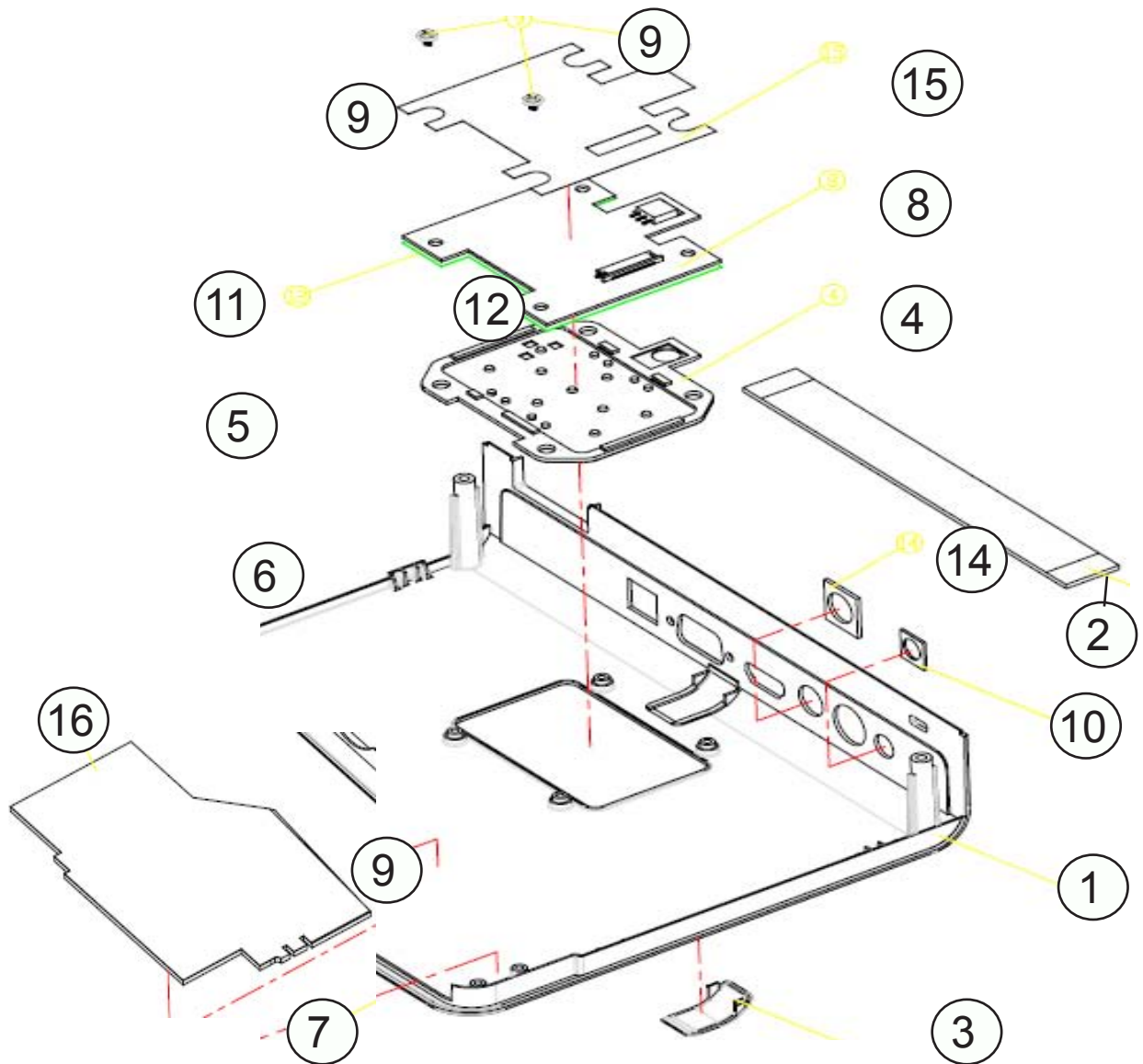

| ITEM | P/N | DESCRIPTION | Supply |
|------|--------------|--|--------|
| | 70.89Y25GR01 | ASSY TOP COVER MODULE FOR P3150(SERVICE) | |
| 1 | 61.89Y02G001 | TOP COVER P3150 | N |
| 2 | 42.89501G002 | CABLE FPC 24P P=0.5 150mm KE | |
| 3 | 51.89Y04G001 | TOP IR LENS P3150 | N |
| 4 | 51.89Y11G002 | KEYPAD BUTTON P+R P3150 | |
| 5 | 51.89Y06G001 | ZOOM RING HOLDER P3150 | N |
| 6 | 51.89Y07G002 | ZOOM RING P3150 | |
| 7 | 51.89Y12G001 | TOP COVER PILLAR P3150 | N |
| 8 | 80.89Y03G001 | PCBA KEYPAD BD FOR P3150 | |
| 9 | 85.1D122G030 | SCREW PAN MECH M2*3 Ni(W/WSHER | N |
| 10 | 41.87W02G001 | EMI I/O GASKET (S-VIDEO /RS232 | N |
| 11 | 41.89Y02G001 | EMI GASKET W8*H1*L30 | N |
| 12 | 51.89Y13G001 | METAL DOME P3150 | N |
| 13 | 41.87W02G001 | EMI I/O GASKET (S-VIDEO /RS232 | N |
| 14 | 41.83M11G001 | S-VIDEO GASKET 2400MP | N |
| 15 | 51.89Y15G001 | KEYPAD TAPE P3150 | N |
| 16 | 52.89Y06G001 | FRAME AL FOIL/F12 LAMP P3150 | N |

ASSY FRONT COVER P3150

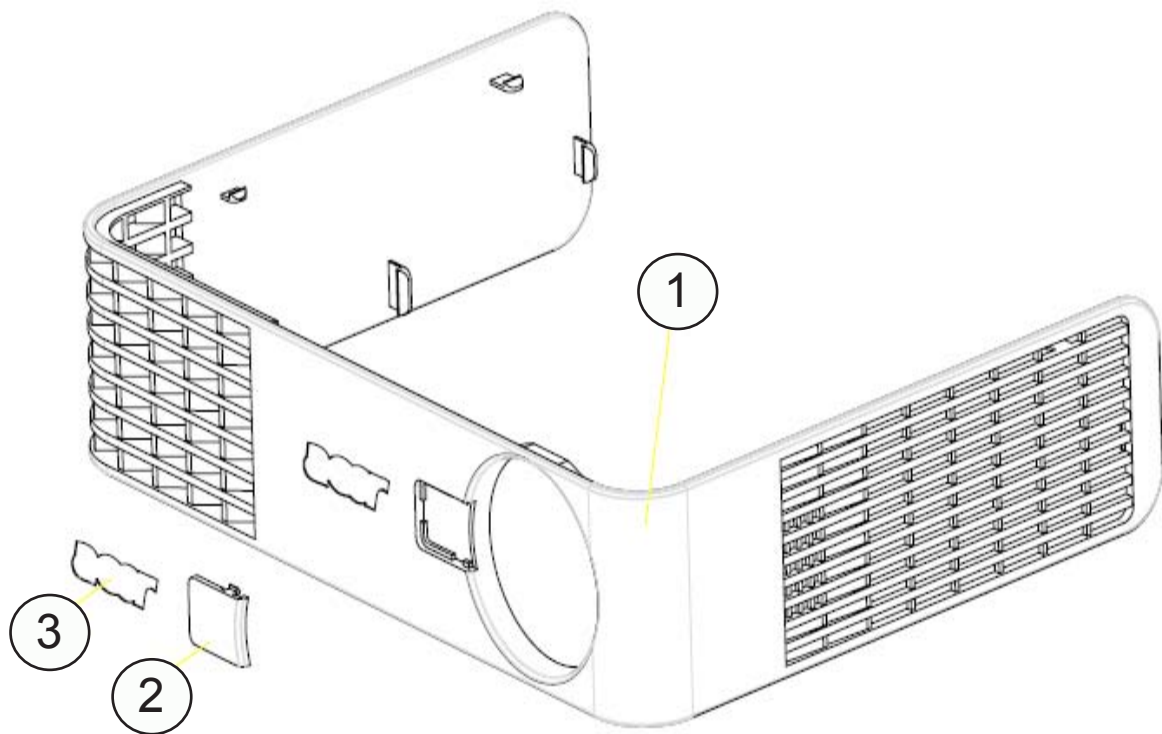

| ITEM | P/N | DECRPTION | Supply |
|------|--------------|--|--------|
| | 70.89Y24GR01 | ASSY FRONT COVER MODULE FOR P3150/P3250(SERVICE) | |
| 1 | 51.89Y01G001 | FRONT COVER P3150 | N |
| 2 | 51.89Y03G001 | FRONT IR LENS P3150 | N |
| 3 | 61.88T15G001 | ACER LOGO FOR X1160 | |

ASSY BOTTOM COVER P3150

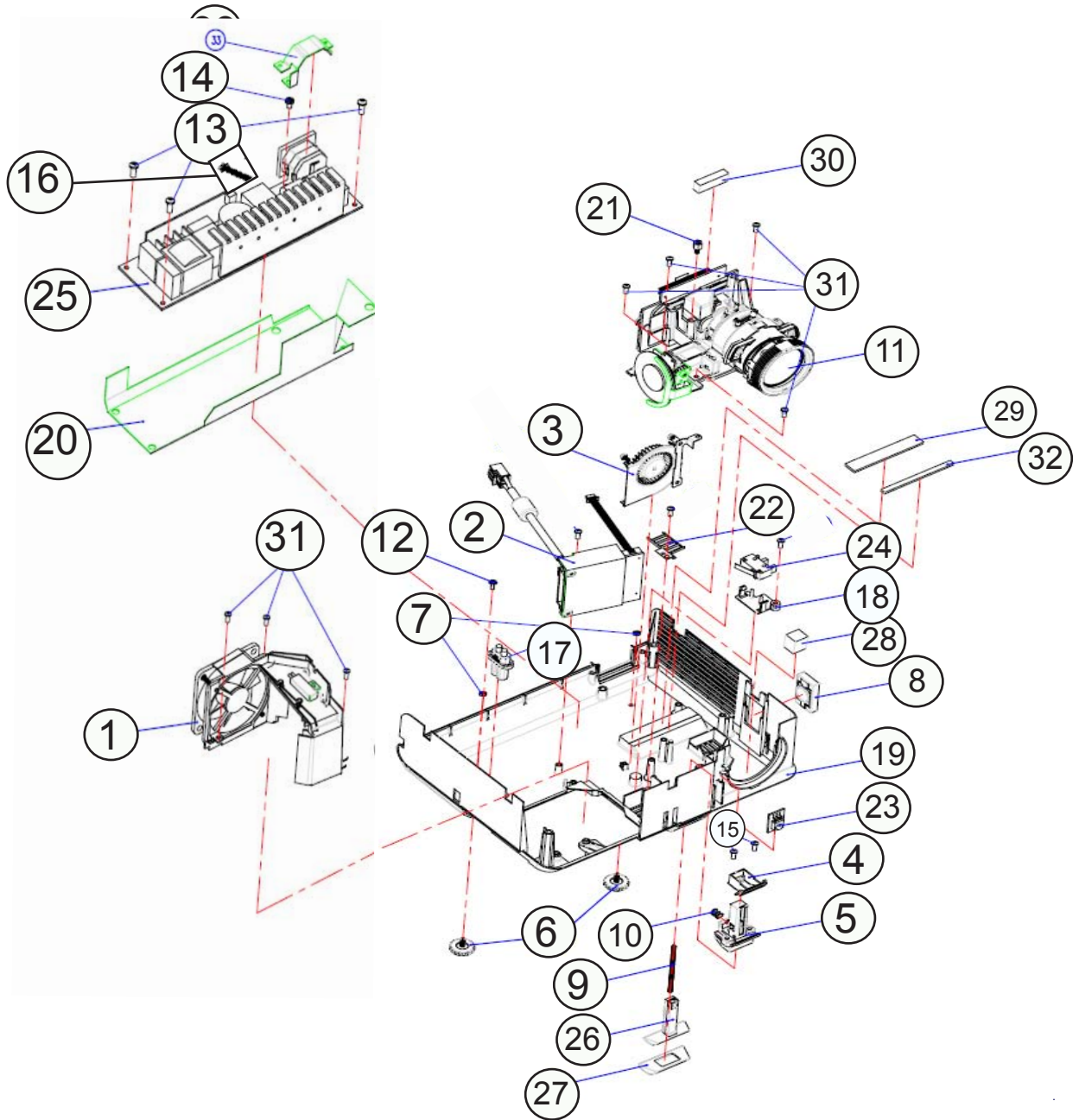

| ITEM | P/N | DESCRIPTION | Supply |
|------|--------------|--|--------|
| 1 | 70.89Y17G001 | ASSY LAMP HOUSING MODULE M209X | N |
| 2 | 70.89Y13G001 | ASSY DC-DC MODULE P3150 | N |
| 3 | 70.89S09G001 | ASSY BLOWER 4510 MODULE M209X | N |
| 4 | 51.89Y08G001 | ELEVATOR PUSH BUTTON P3150 | |
| 5 | 51.89Y09G001 | ELEVATOR BASE P3150 | N |
| 6 | 52.89Y02G001 | ADJUST FOOT P3150 | N |
| 7 | 86.00122G015 | NUT HEX M2.0*0.4P L15 Ni | N |
| 8 | 70.89Y06G001 | ASSY SPEAKER MODULE P3150 | N |
| 9 | 61.89S20G001 | ELEVATOR BASE SPRING M209X | N |
| 10 | 61.89S21G001 | ELEVATOR PUSH SPRING M209X | N |
| 11 | 70.89Y04G001 | ASSY OPTICAL ENGINE MODULE P31 | N |
| 12 | 85.1D122G030 | SCREW PAN MECH M2*3 Ni(W/WSHER | N |
| 13 | 85.1A123G060 | SCREW PAN MECH M3*6 NI | N |
| 14 | 85.1C224G051 | SCREW PAN MECH M4*5 COLOR W/TO | N |
| 15 | 85.1A126G040 | SCREW PAN MECH M2.6*4 Ni | N |
| 16 | 42.00472G001 | W.A. 5P #28 140MM MAIN BOARD/B | |
| 17 | 42.00491G001 | W.A. 2P #22 FEMALE 6KV 150 75 | N |
| 18 | 51.89S18G001 | INTERLOCK SWITCH HOLDER PC M20 | N |
| | 70.89Y26GR01 | ASSY BOTTOM COVER MODULE FOR P3150/P3250 (SERVICE) | |
| 19 | 61.89Y01G001 | BASE COVER P3150 | N |
| 20 | 51.89Y14G001 | BALLAST MYLAR P3150 | N |
| 21 | 61.89S24G001 | MAIN BOARD STAND-OFF M2.6X4.0m | N |
| 22 | 61.89S25G001 | COLOR WHEEL VENT SUS304 M209X | N |
| 23 | 80.89S05G001 | PCBA IR SENSOR BD FOR M209X | |
| 24 | 75.89S06G002 | NEW BUY ASSY INTERLOCK SWITCH | |
| 25 | 70.89Y27GR01 | ASSY OSRAM BALLAST FOR P3150/P3250 (SERVICE) | |
| 26 | 51.89Y10G001 | ELEVATOR SUPPORT P3150 | N |
| 27 | 52.89Y03G002 | ELEVATOR FOOT P3150 | |
| 28 | 41.89S01G001 | EMI GASKET W10*H13*L12 | N |
| 29 | 41.89Y01G001 | EMI GASKET W10*H3*L55 | N |
| 30 | 41.89S05G001 | EMI GASKET W6.5*H12*L30 | N |
| 31 | 85.1A326G060 | SCREW PAN HEAD MECH M2.6*6 BLA | N |
| 32 | 52.89Y05G001 | DMD BOTTOM-SIDE THERMAL PAD GR | N |
| 33 | 61.89Y03G001 | AC INLET BRACKET P3150 | |

ASSY MAIN BOARD MODULE P3150

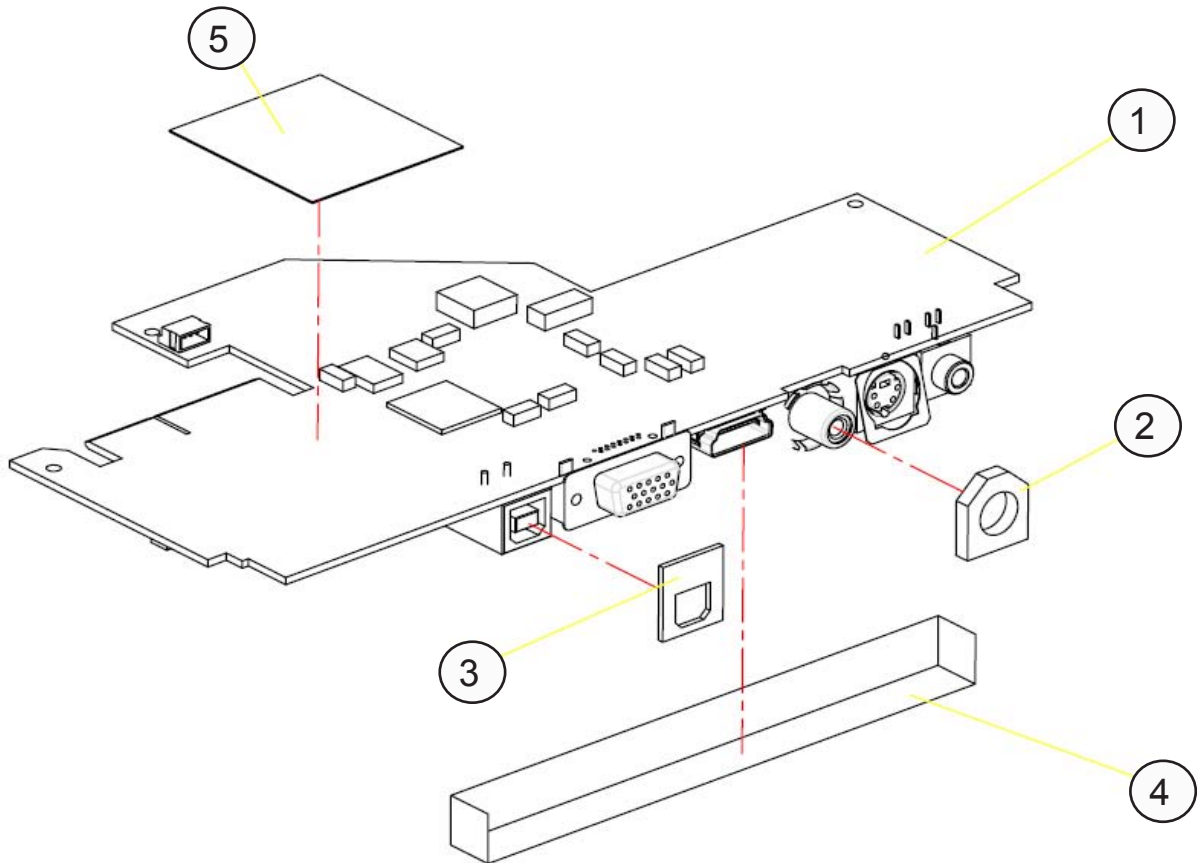

| ITEM | P/N | DESCRIPTION | Supply |
|------|--------------|---|--------|
| | 70.89Y23GR01 | ASSY PCBA MAIN BD MODULE FOR P3150(SERVICE) | |
| 1 | 80.89Y01G001 | PCBA MAIN BOARD FOR P3150 | N |
| 2 | 41.82B17G001 | EMI VIDEO GASKET | N |
| 3 | 41.82G03G001 | EMI GASKET USB CONNECTOR EP719 | N |
| 4 | 41.89S14G001 | EMI TAPE W30*L30 | N |
| 5 | 51.89Y17G001 | MAIN BOARD LIGHTCUT MYLAR P315 | N |

ASSY DC-DC MODULE P3150

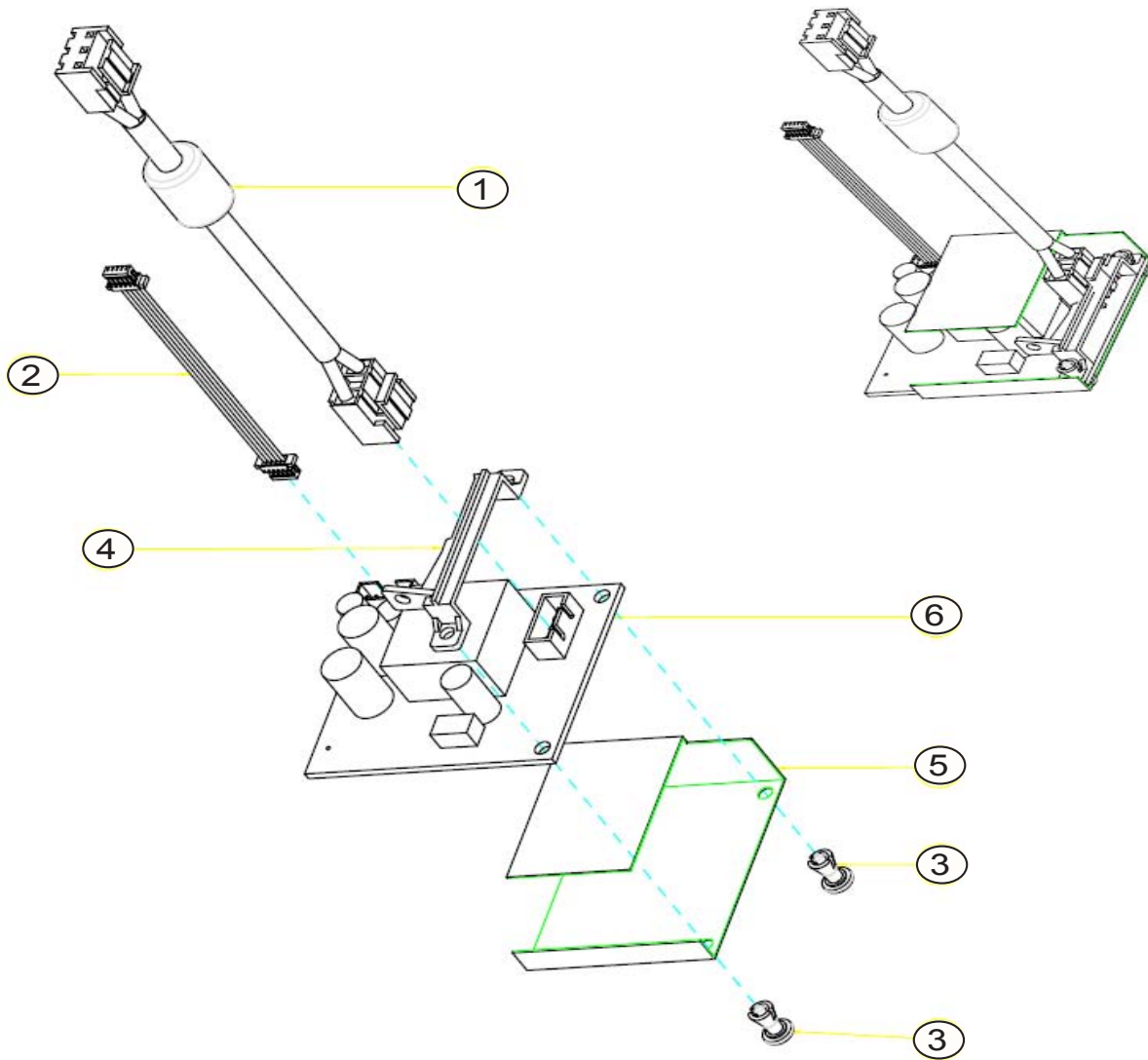

| ITEM | P/N | DESCRIPTION | Supply |
|------|--------------|---|--------|
| | 70.89Y28GR01 | ASSY DC-DC MODULE FOR P3150/P3250 (SERVICE) | |
| 1 | 42.004A1G001 | W.A.4P #24/#26 100mm DC.DC/BALLAST | |
| 2 | 42.004B1G001 | W.A. 5P #26 140mm DC-DC/MAIN BOARD M209X | |
| 3 | 51.00061G001 | PLASTIC RIVET E3.0 SR-3L "A0" | N |
| 4 | 51.89S17G001 | DC HOLDER PC M209X | N |
| 5 | 51.89S23G001 | DC-DC MYLAR M209X | N |
| 6 | 75.89S08G001 | ASSY MATRITEK D2D M209P | N |

ASSY LAMP HOUSING MODULE P3150

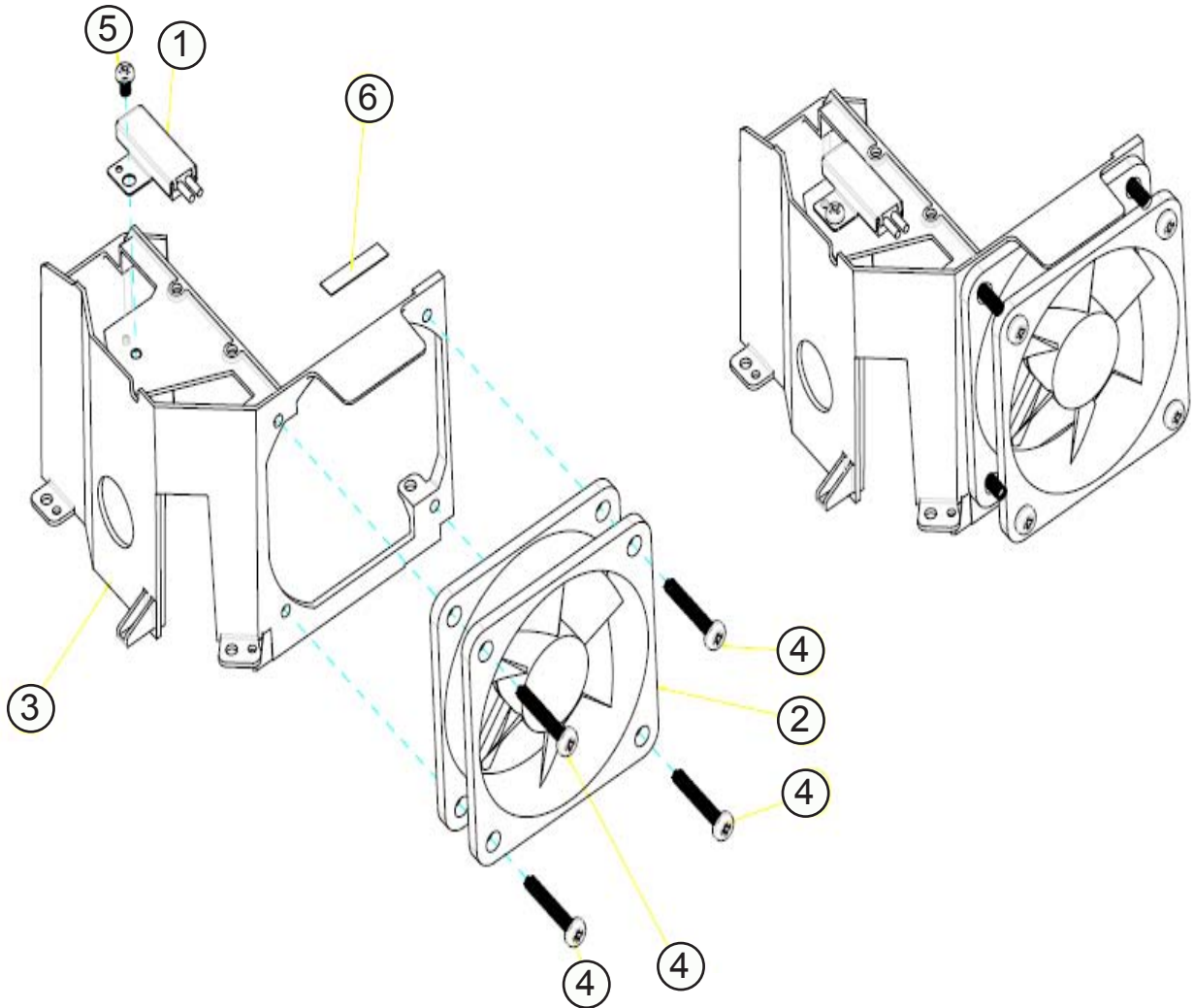

| ITEM | P/N | DESCRIPTION | Supply |
|------|--------------|--|--------|
| 1 | 43.89S01G001 | TH-RMAI SWITCH WITH BRACKET (KLIX-ON YSII) | |
| 2 | 49.85M03G001 | SYSTEM FAN/55*55*15mm | |
| 3 | 61.89Z06G001 | LAMP HOUSING MG ALLOY EX330 | N |
| 4 | 85.1A123G180 | SCREW PAN MECH M3*18 NI EP910 | N |
| 5 | 85.1A126G040 | SCREW PAN MECH M2.6*4 Ni | N |
| 6 | 41.89S03G001 | EMI TAPE W5*L25 H0.65 | N |

ASSY SPEAKER MODULE P3150

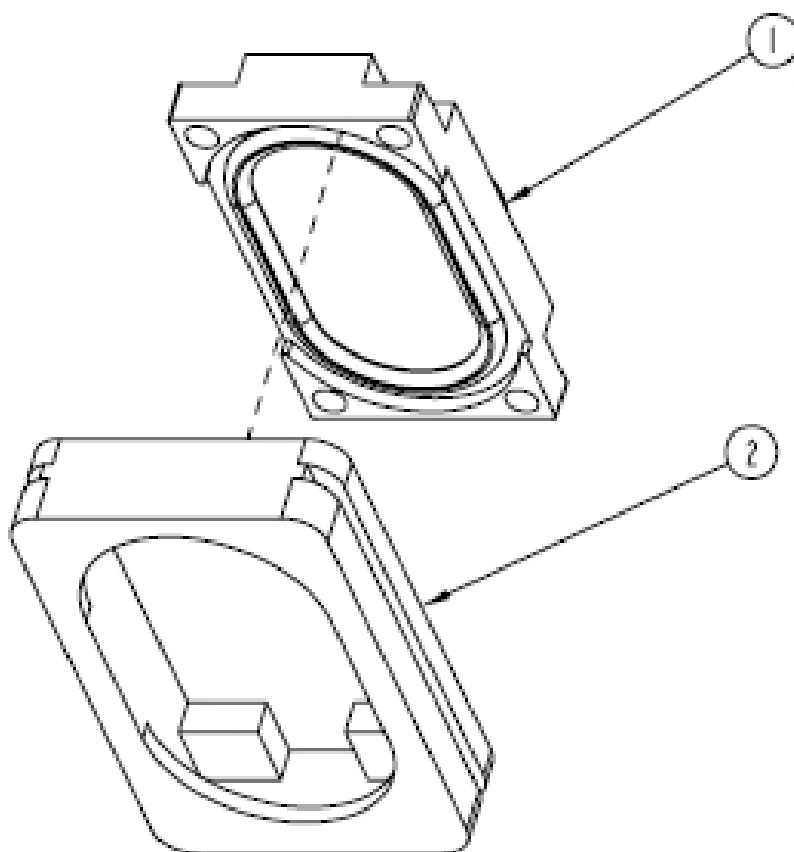

| ITEM | P/N | DESCRIPTION | Supply |
|------|--------------|------------------------------------|--------|
| 1 | 49.89Y01G001 | SPEAKER MINI IW 4 ohm 140 mm P3150 | |
| 2 | 52.89Y01G001 | SPEAKER RUBBER P3150 | N |

ASSY ENGINE MODULE P3150

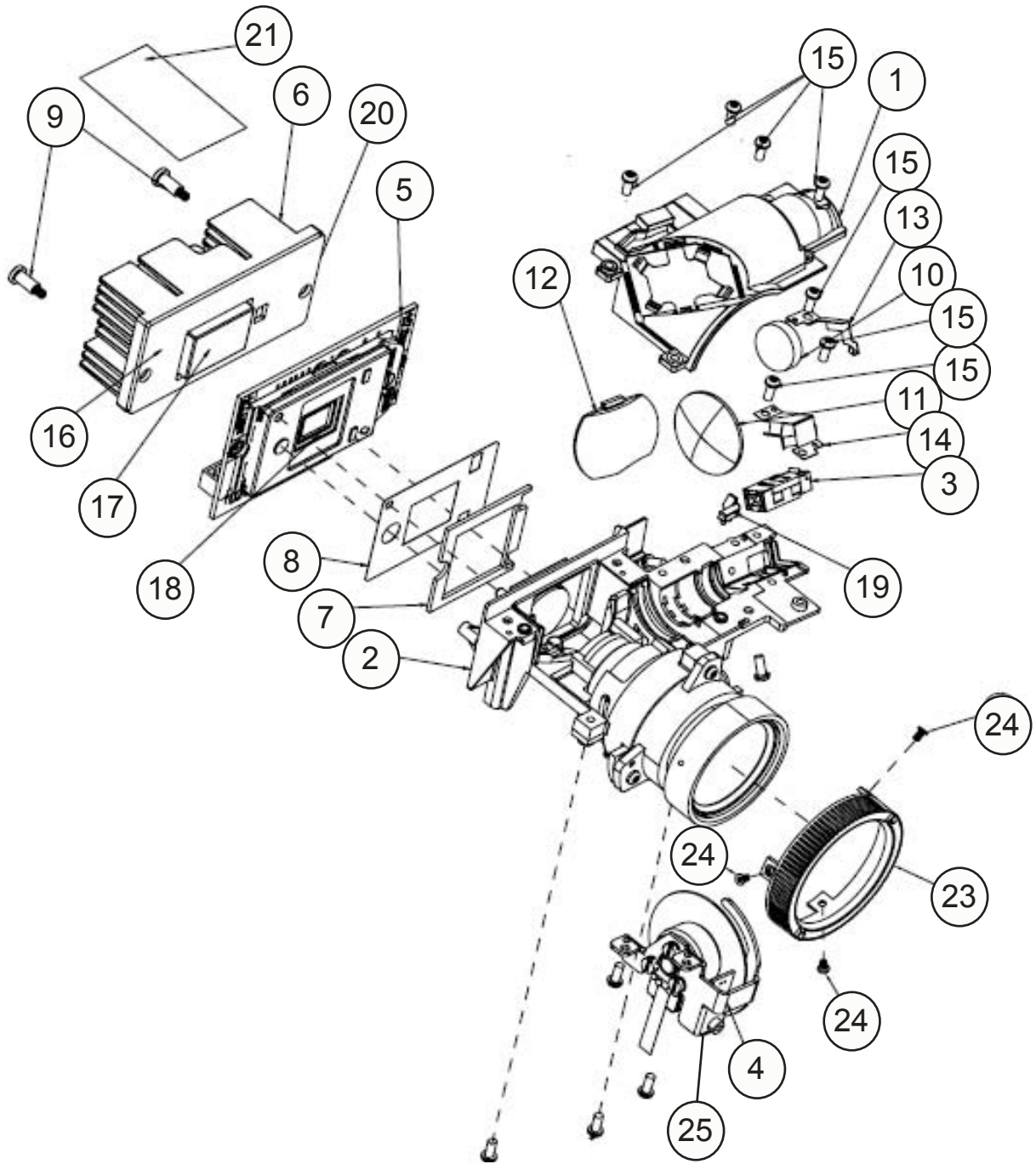

| ITEM | P/N | DECRPTION | Supply |
|------|--------------|---|--------|
| | 70.89Y22GR01 | ASSY ENGINE MODULE FOR P3150/ P3250(SERVICE) | |
| 1 | 70.89Y15G001 | ASSY ENGINE BOTTOM COVER P3150 | N |
| 2 | 70.89Y05G001 | ASSY ENGINE BASE MODULE P3150 | N |
| 3 | 70.89Y16G001 | ASSY ROD MODULE P3150 | N |
| 4 | 70.89Y21GR01 | ASSY COLOR WHEEL MODULE P3150 | |
| 5 | 80.89S02G001 | PCBA DMD BOARD FOR M209X | |
| 6 | 61.89S10G001 | DMD HEATSINK AL M209X | N |
| 7 | 52.88N04G002 | DMD RUBBER NEW 1.3T X15 | N |
| 8 | 61.88N15G001 | DMD MASK,SUS301,X15 | N |
| 9 | 85.4A826G118 | STEP SCREW FOR TYPEX DMD M2.6*11.8mm,X15 | |
| 10 | 23.88N20G001 | YO CONDENSER1 FOR X15 | N |
| 11 | 23.88N20G011 | YO CONDENSER2 FOR X15 | N |
| 12 | 23.88N06G011 | YO PLASTIC RELAY FOR X15 | N |
| 13 | 61.88N13G002 | ROD COVER NEW,SUS301,X15 | N |
| 14 | 61.88N12G001 | ROD SPRING,SUS301,X15 | N |
| 15 | 85.1A526G060 | SCREW PAN MECH M2.6*6 NI NYLOK | N |
| 16 | 52.88N03G002 | HEAT SINK RUBBER(X15) X1160 | N |
| 17 | 52.87J01G001 | DMD THERMAL PAD 25*17*0.5t FUJIPOLY SAR- GON GR-Hn | |
| 18 | 48.87K01G001 | DMD Type-X 800x600 PIXEL 0.55" | |
| 19 | 61.88N39G001 | STOP MASK MG X15 | N |
| 20 | 61.89Y06G001 | HEX SCREW M2.6*H6.8*L5, STEEL | N |
| 21 | 41.82K09G001 | EMI TAPE 30*50mm | N |
| 22 | 85.0A126G040 | SCREW DOUBLE FLAT MECH M2.6*4Ni | N |
| 23 | 51.89Y05G001 | FOCUS RING P3150 | |
| 24 | 85.WA321G040 | SCREW PAN TAP M1.7*4 BLACK | N |
| 25 | 80.88N04G001 | PCBA PHOTO SENSOR BOARD FOR EP721 | |

AK. P3150

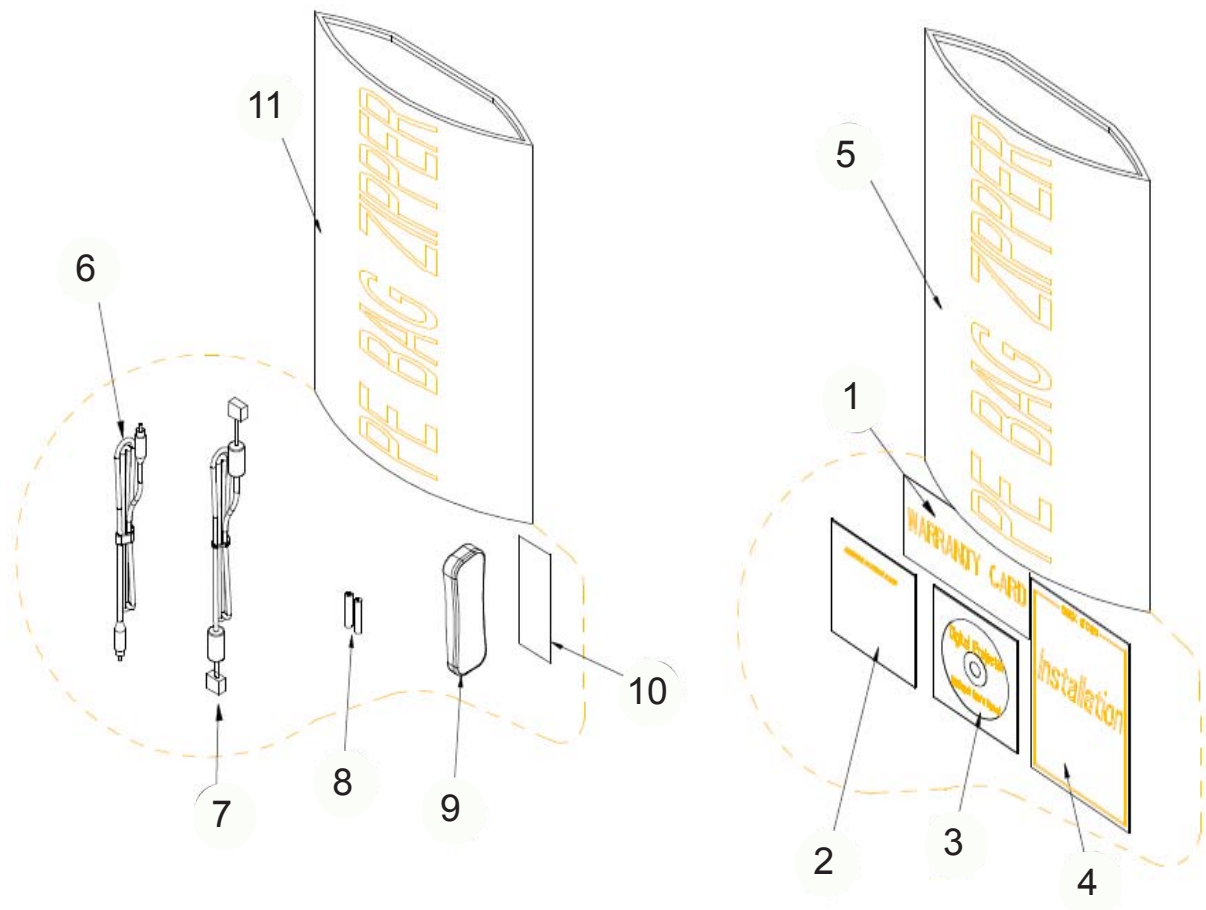

| ITEM | P/N | DESCRIPTION | Supply |
|------|--------------|--------------------------------|--------|
| 1 | 36.00006G031 | WARRANTY CARD ,EUROPE FOR ACER | N |
| 2 | 36.00027G001 | SERVICE STATION CARD | N |
| 3 | 36.89Y01G001 | USER'S GUIDE MULTILINGUAL (C | N |
| 4 | 36.89Y02G001 | QUICK START CARD MULTILINGUA | N |
| 5 | 51.86213G002 | PE BAG ZIPPER #9 W/RECYCLING M | N |
| 6 | 42.00232G001 | CABLE COMPOSITE VIDEO 2M YELLO | N |
| 7 | 42.83M09G101 | CABLE MINI JACK TO MINI JACK | N |
| 8 | 46.82V02G001 | BATTERY #4 1.5V R04 PD120 | N |
| 9 | 45.87U01G106 | INFRARED REMOTE CONTROLLER L | |
| 10 | 36.00029G001 | SECURITY CARD FOR ACER | N |
| 11 | 51.86213G002 | PE BAG ZIPPER #9 W/RECYCLING M | N |

DP. P3150

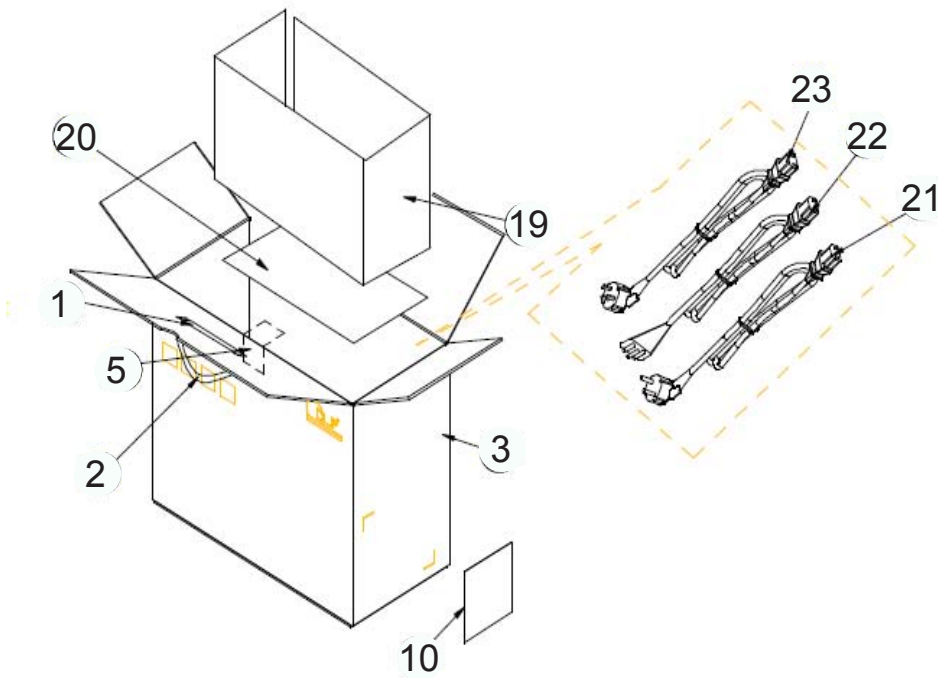
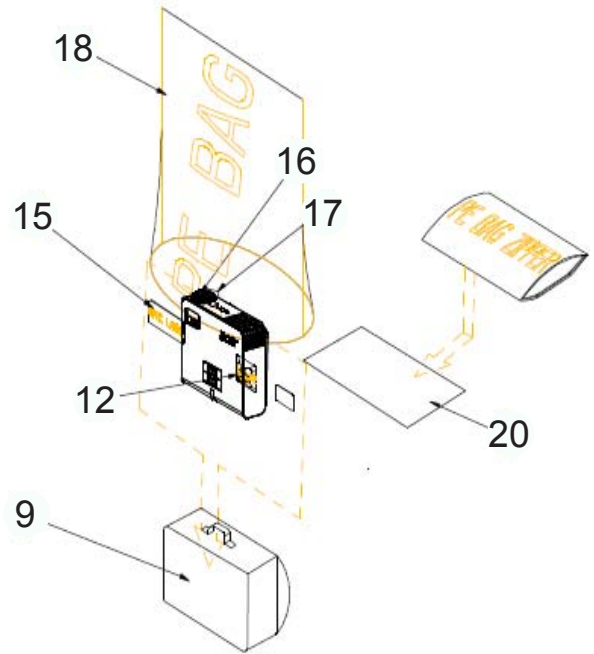

| ITEM | P/N | DESCRIPTION | Supply |
|------|--------------|---|--------|
| 1 | 51.00201G001 | HANDLE BAR 1.PE HD70 | N |
| 2 | 51.00200G001 | HANDLE BAR 2. PE HD70 | N |
| 3 | 55.89Y01G001 | CARTON CARRY BOX P3150 | N |
| 4 | 55.89Y02G001 | CENTER PAPER BOX P3150 | N |
| 5 | 35.82L04G001 | ACER TAPE 45M FOR CARTON | N |
| 6 | 55.87W04G001 | CORNER PAPER P5271 | N |
| 7 | 58.86202GC02 | COVER PALLET 1150*970mm FOR 34 | N |
| 8 | 58.86201GC02 | WOOD PALLET 48"*40*5"(DOUBLE F | N |
| 9 | 53.89Y01G001 | SOFT CARRY BAG P3150 | N |
| 10 | 35.52302G091 | LABEL CARTON 108*92 BLANK | N |
| 11 | 55.87202G001 | BOTTOM PAPER COVER PLATE 1230* | N |
| 12 | 57.00001G001 | PACK SIO2 DRIER 20g | N |
| 13 | 35.82L04G001 | LAMP WARNING LABEL ARES A | N |
| 14 | 35.82V02G001 | LABEL CARTON(SEAL) 110*50mm PD | N |
| 15 | 35.85M02G001 | SPEC LABEL PD311 | N |
| 16 | 52.89Y04G002 | LENS-CAP FOR P3150 | N |
| 17 | 51.89Y16G001 | LENS CAP STRAP P3150 | N |
| 18 | 51.00174G002 | PE BAG 380*310*0.07mm FOR OP | N |
| 19 | 56.89Z01G001 | AIR BAG RIM EX330 | N |
| 20 | 56.89Z02G001 | AIR BAG TOP/BOTTOM EX330 | N |
| 21 | 42.00120G011 | CABLE POWER CORD 1.8M SP-023/IS-14 EUROPE DIS-WARNING LABEL | |
| 22 | 42.00110G011 | CABLE POWER CORD 1.8M SP-60/IS-14 UK DIS-WARNING LABEL | |
| 23 | 42.00131G011 | CABLE POWER CORD 1.8M SP-027/IS-14 SWITZERLAND DIS-WARNING LABEL | |

DC. P3250

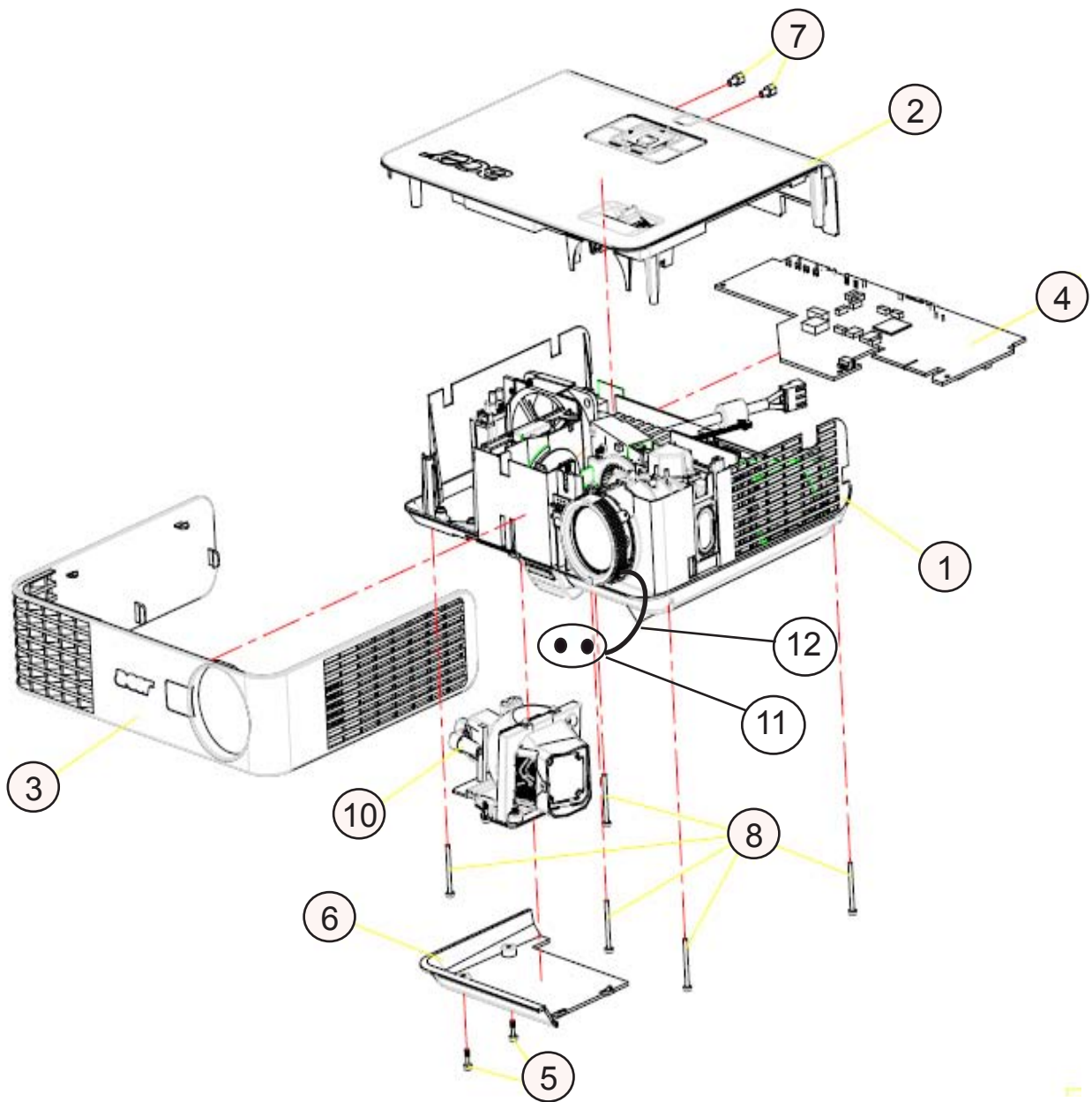

| ITEM | P/N | DESCRIPTION | Supply |
|------|--------------|---|--------|
| 1 | 70.89Y03G001 | ASSY BOTTOM COVER P3150 | N |
| 2 | 70.89Y01G001 | ASSY TOP COVER MODULE P3150 | N |
| 3 | 70.89Y02G001 | ASSY FRONT COVER P3150 | N |
| 4 | 70.89Y08G001 | ASSY MAIN BOARD MODULE P3150 | N |
| 5 | 61.85928G001 | LAMP HOUSING SHOULDER SCREW SB | N |
| 6 | 51.89Y02G002 | LAMP COVER P3150 | |
| 7 | 85.005AG040 | SCREW I/O STEEL #4-40UNC*H4*L5 | N |
| 8 | 85.1A326G250 | SCREW PAN MECH M2.6*25 BLACK | N |
| 9 | 51.00001G001 | CABLE TIE PG-YJ-80 | N |
| | SP.89Y01GC01 | LAMP MODULE FOR PROJECTOR P3150/ P3250 | |
| 10 | 70.89Y14G001 | ASSY LAMP MODULE P3150 | N |
| 11 | 52.89Y04G002 | LENS-CAP FOR P3150 | |
| 12 | 51.89Y16G001 | LENS CAP STRAP P3150 | |

ASSY BLOWER 4510 MODULE P3250

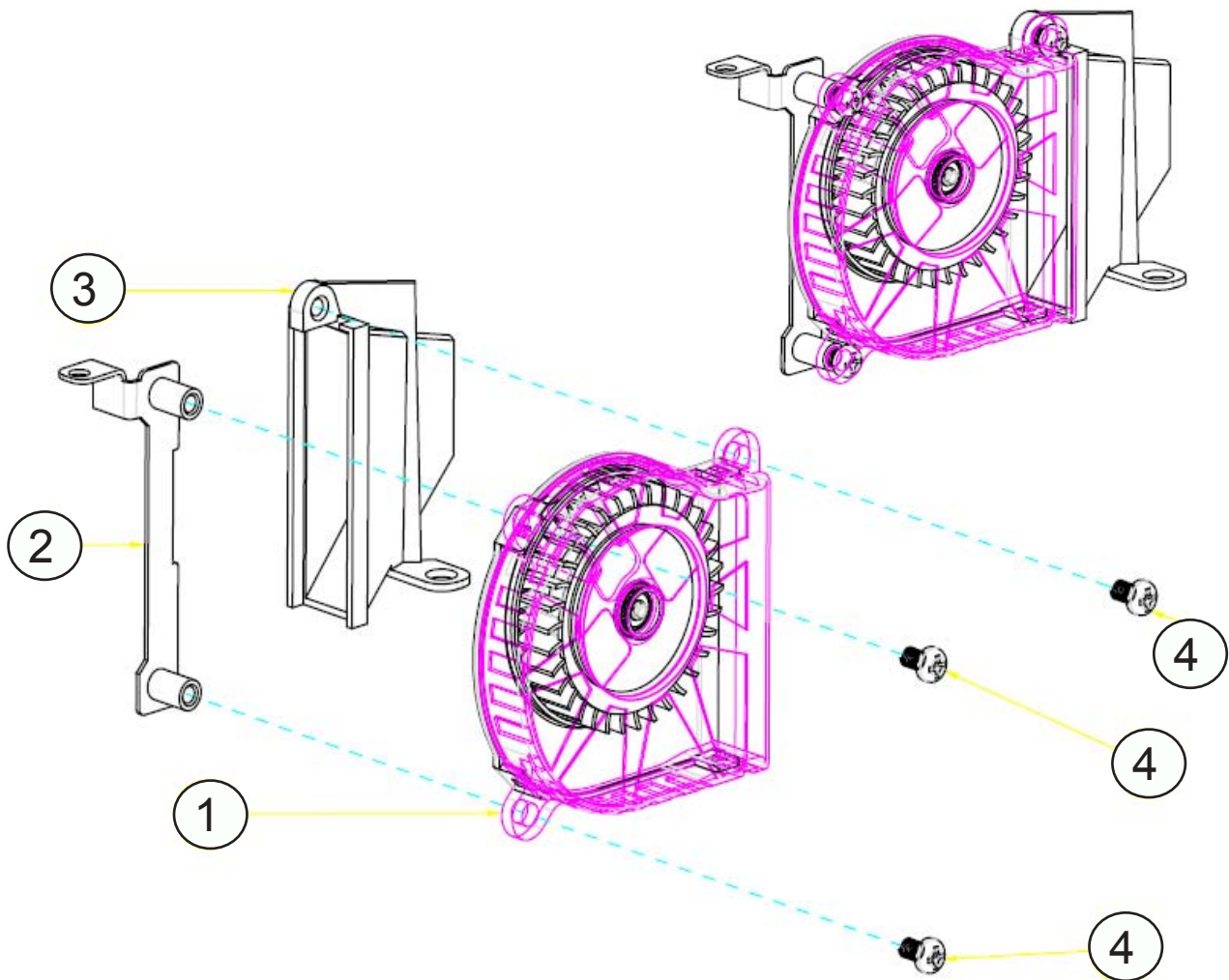

| ITEM | P/N | DESCRIPTION | Supply |
|------|--------------|--------------------------------|--------|
| 1 | 49.89S01G001 | LAMP BLOWER / 45*45*10 mm, 60m | |
| 2 | 61.89S13G001 | BLOWER 4510 HOLDER SECC M209X | N |
| 3 | 61.89S11G001 | LAMP BLOWER 4510 DUCT AL M209X | N |
| 4 | 85.1A126G040 | SCREW PAN MECH M2.6*4 Ni | N |

ASSY TOP COVER MODULE P3250

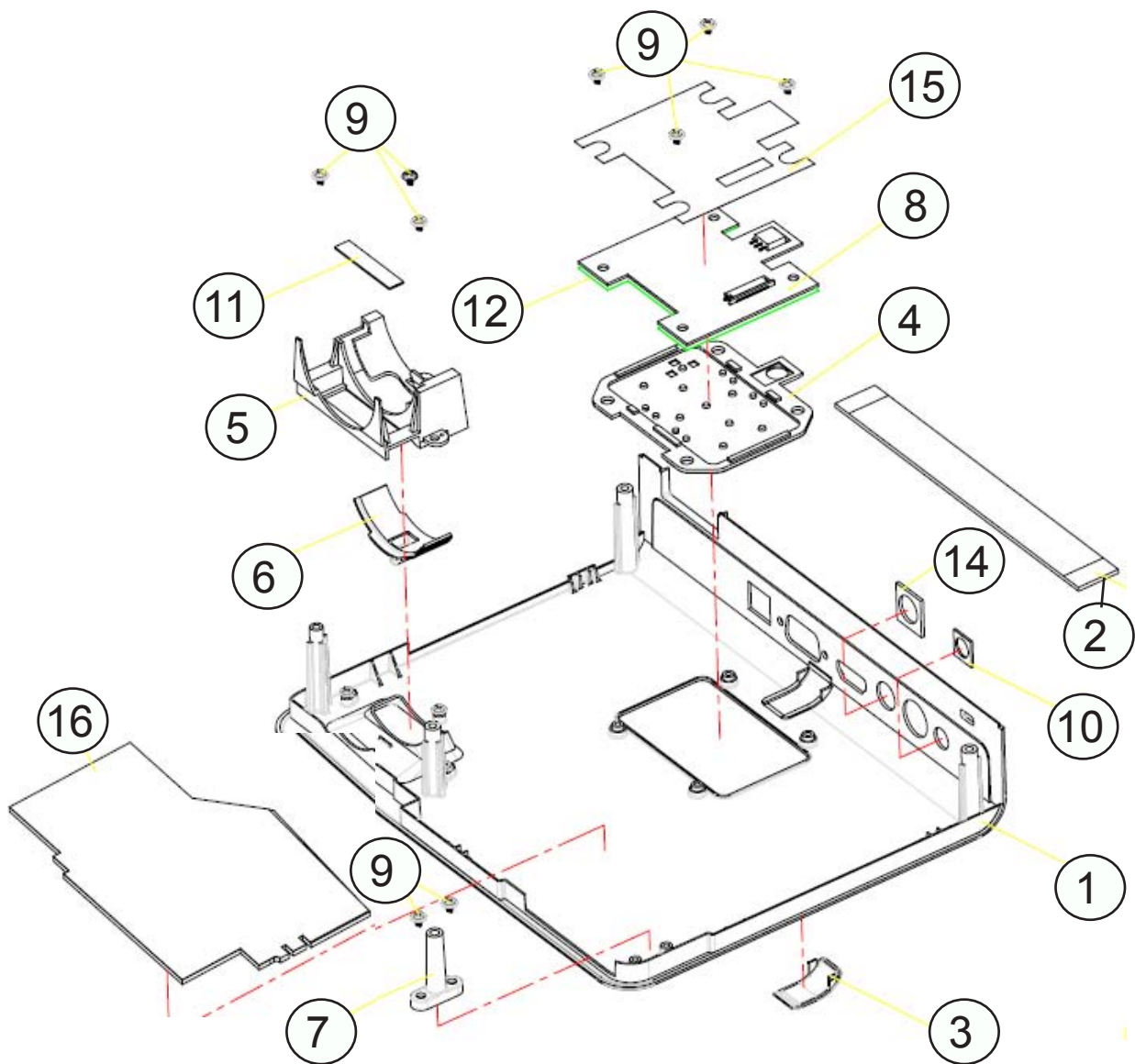

| ITEM | P/N | DESCRIPTION | Supply |
|------|--------------|--|--------|
| | 70.89Y30GR01 | ASSY TOP COVER MODULE FOR P3250(SERVICE) | |
| 1 | 61.89Y02G001 | TOP COVER P3150 | N |
| 2 | 42.89501G002 | CABLE FPC 24P P=0.5 150mm KE | |
| 3 | 51.89Y04G001 | TOP IR LENS P3150 | N |
| 4 | 51.89Y11G002 | KEYPAD BUTTON P+R P3150 | |
| 5 | 51.89Y06G001 | ZOOM RING HOLDER P3150 | N |
| 6 | 51.89Y07G002 | ZOOM RING P3150 | |
| 7 | 51.89Y12G001 | TOP COVER PILLAR P3150 | N |
| 8 | 80.89Y03G001 | PCBA KEYPAD BD FOR P3150 | |
| 9 | 85.1D122G030 | SCREW PAN MECH M2*3 Ni(W/WSHER | N |
| 10 | 41.87W02G001 | EMI I/O GASKET (S-VIDEO /RS232 | N |
| 11 | 41.89Y02G001 | EMI GASKET W8*H1*L30 | N |
| 12 | 51.89Y13G001 | METAL DOME P3150 | N |
| 13 | 41.87W02G001 | EMI I/O GASKET (S-VIDEO /RS232 | N |
| 14 | 41.83M11G001 | S-VIDEO GASKET 2400MP | N |
| 15 | 51.89Y15G001 | KEYPAD TAPE P3150 | N |
| 16 | 52.89Y06G001 | FRAME AL FOIL/F12 LAMP P3150 | N |

ASSY FRONT COVER P3250

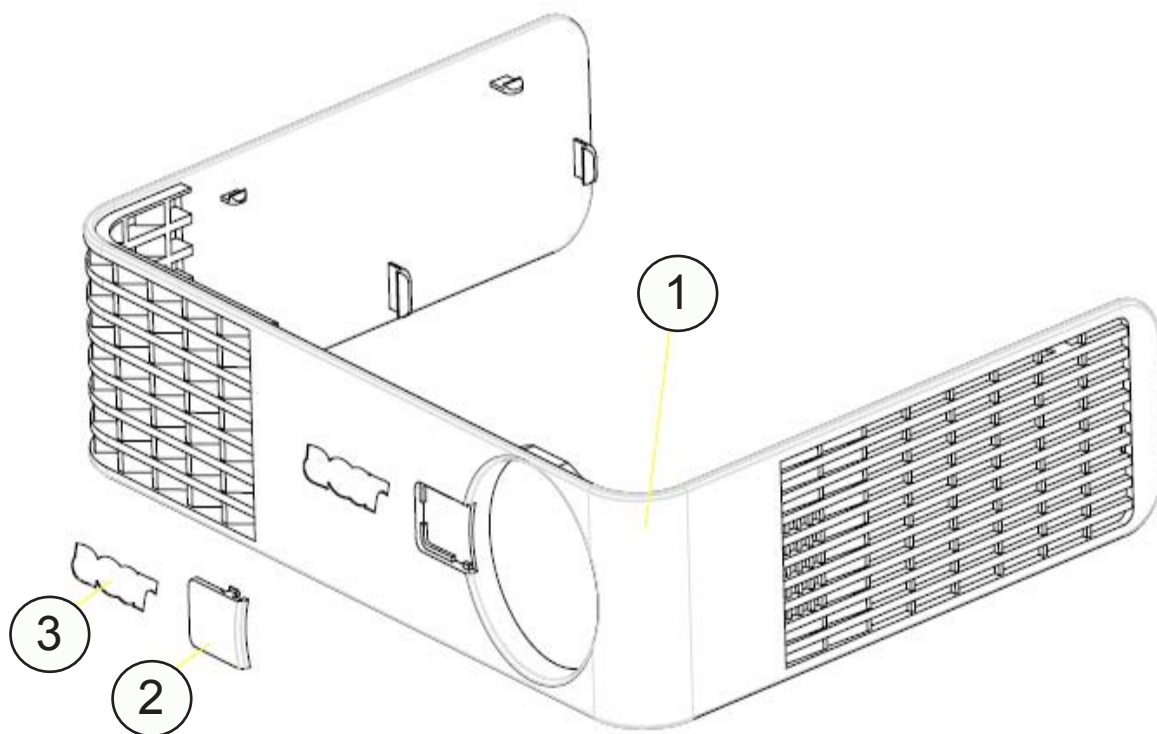

| ITEM | P/N | DESCRIPTION | Supply |
|------|--------------|--|--------|
| | 70.89Y24GR01 | ASSY FRONT COVER MODULE FOR P3150/P3250(SERVICE) | |
| 1 | 51.89Y01G001 | FRONT COVER P3150 | N |
| 2 | 51.89Y03G001 | FRONT IR LENS P3150 | N |
| 3 | 61.88T15G001 | ACER LOGO FOR X1160 | N |

ASSY BOTTOM COVER P3250

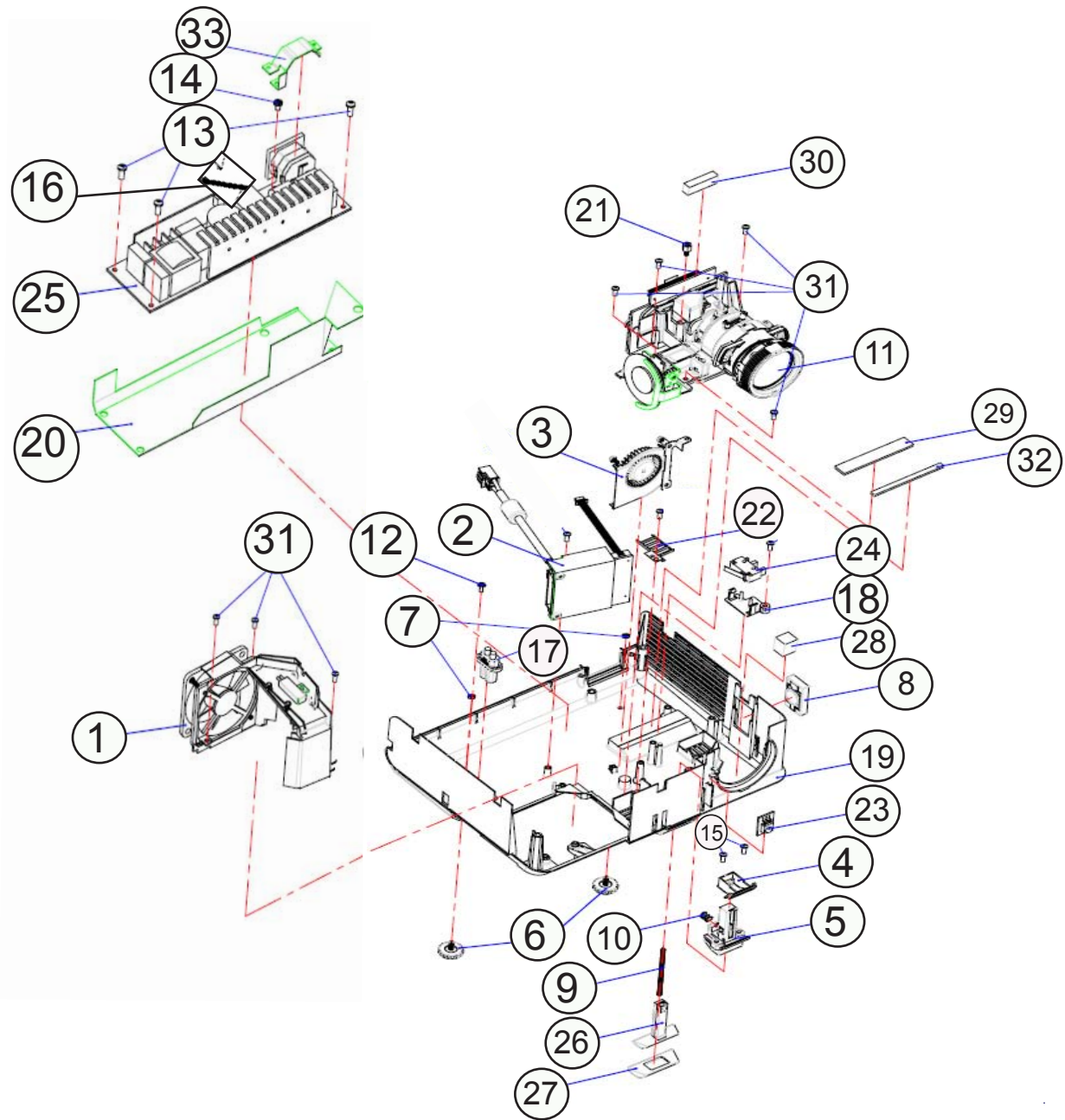

| ITEM | P/N | DESCRIPTION | Supply |
|------|--------------|--|--------|
| 1 | 70.89Y17G001 | ASSY LAMP HOUSING MODULE M209X | N |
| 2 | 70.89Y13G001 | ASSY DC-DC MODULE P3150 | N |
| 3 | 70.89S09G001 | ASSY BLOWER 4510 MODULE M209X | N |
| 4 | 51.89Y08G001 | ELEVATOR PUSH BUTTON P3150 | |
| 5 | 51.89Y09G001 | ELEVATOR BASE P3150 | N |
| 6 | 52.89Y02G001 | ADJUST FOOT P3150 | N |
| 7 | 86.00122G015 | NUT HEX M2.0*0.4P L15 Ni | N |
| 8 | 70.89Y06G001 | ASSY SPEAKER MODULE P3150 | N |
| 9 | 61.89S20G001 | ELEVATOR BASE SPRING M209X | N |
| 10 | 61.89S21G001 | ELEVATOR PUSH SPRING M209X | N |
| 11 | 70.89Y04G001 | ASSY OPTICAL ENGINE MODULE P31 | N |
| 12 | 85.1D122G030 | SCREW PAN MECH M2*3 Ni(W/WSHER | N |
| 13 | 85.1A123G060 | SCREW PAN MECH M3*6 NI | N |
| 14 | 85.1C224G051 | SCREW PAN MECH M4*5 COLOR W/TO | N |
| 15 | 85.1A126G040 | SCREW PAN MECH M2.6*4 Ni | N |
| 16 | 42.00472G001 | W.A. 5P #28 140MM MAIN BOARD/B | |
| 17 | 42.00491G001 | W.A.2P#22 FEMALE 6KV 150 75 | N |
| 18 | 51.89S18G001 | INTERLOCK SWITCH HOLDER PC M20 | N |
| | 70.89Y26GR01 | ASSY BOTTOM COVER MODULE FOR P3150/P3250 (SERVICE) | |
| 19 | 61.89Y01G001 | BASE COVER P3150 | N |
| 20 | 51.89Y14G001 | BALLAST MYLAR P3150 | N |
| 21 | 61.89S24G001 | MAIN BOARD STAND-OFF M2.6X4.0m | N |
| 22 | 61.89S25G001 | COLOR WHEEL VENT SUS304 M209X | N |
| 23 | 80.89S05G001 | PCBA IR SENSOR BD FOR M209X | |
| 24 | 75.89S06G002 | NEW BUY ASSY INTERLOCK SWITCH | |
| 25 | 70.89Y27GR01 | ASSY OSRAM BALLAST FOR P3150/P3250 (SERVICE) | |
| 26 | 51.89Y10G001 | ELEVATOR SUPPORT P3150 | N |
| 27 | 52.89Y03G002 | ELEVATOR FOOT P3150 | |
| 28 | 41.89S01G001 | EMI GASKET W10*H13*L12 | N |
| 29 | 41.89Y01G001 | EMI GASKET W10*H3*L55 | N |
| 30 | 41.89S05G001 | EMI GASKET W6.5*H12*L30 | N |
| 31 | 85.1A326G060 | SCREW PAN HEAD MECH M2.6*6 BLA | N |
| 32 | 52.89Y05G001 | DMD BOTTOM-SIDE THERMAL PAD GR | N |
| 33 | 61.89Y03G001 | AC INLET BRACKET P3150 | N |

ASSY MAIN BOARD MODULE P3250

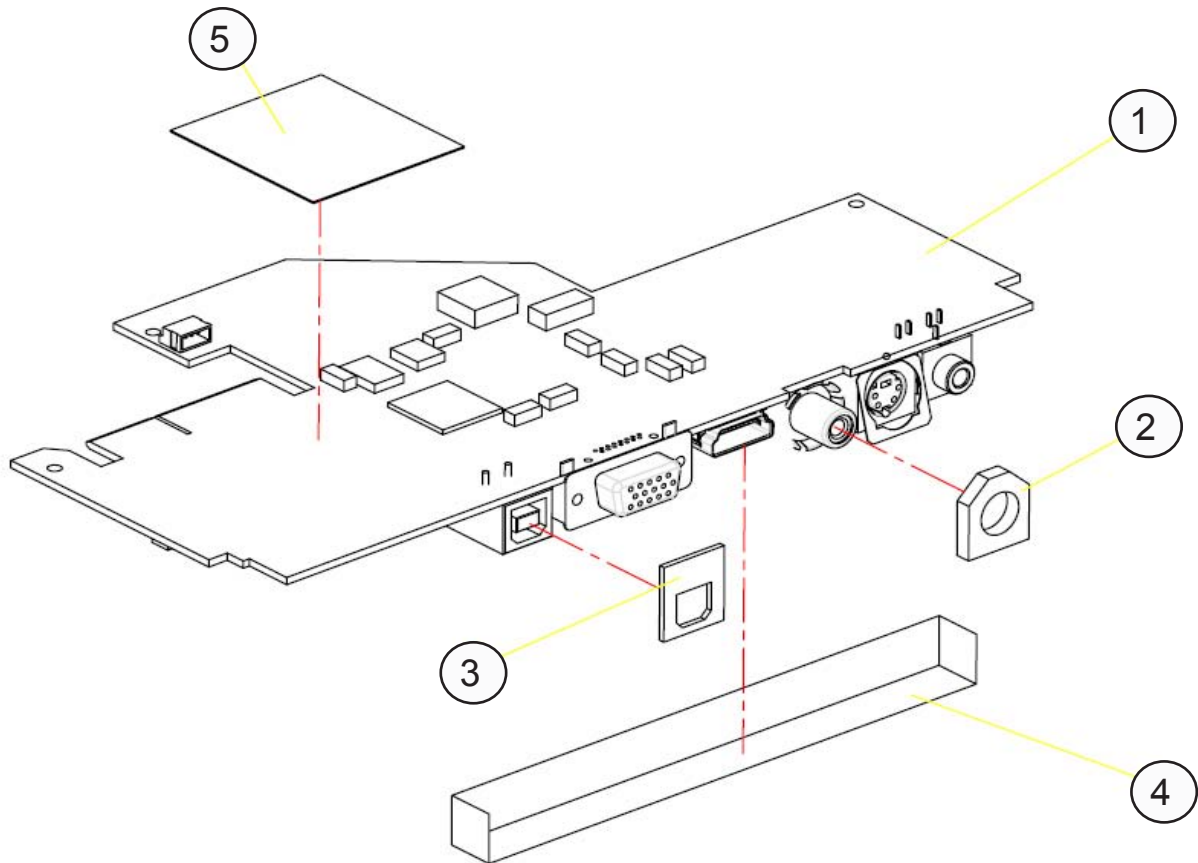

| ITEM | P/N | DESCRIPTION | Supply |
|------|--------------|---|--------|
| | 70.89Y29GR01 | ASSY PCBA MAIN BD MODULE FOR P3250(SERVICE) | |
| 1 | 80.89Y01G001 | PCBA MAIN BOARD FOR P3150 | N |
| 2 | 41.82B17G001 | EMI VIDEO GASKET | N |
| 3 | 41.82G03G001 | EMI GASKET USB CONNECTOR EP719 | N |
| 4 | 41.89S14G001 | EMI TAPE W30*L30 | N |
| 5 | 51.89Y17G001 | MAIN BOARD LIGHTCUT MYLAR P315 | N |

ASSY DC-DC MODULE P3250

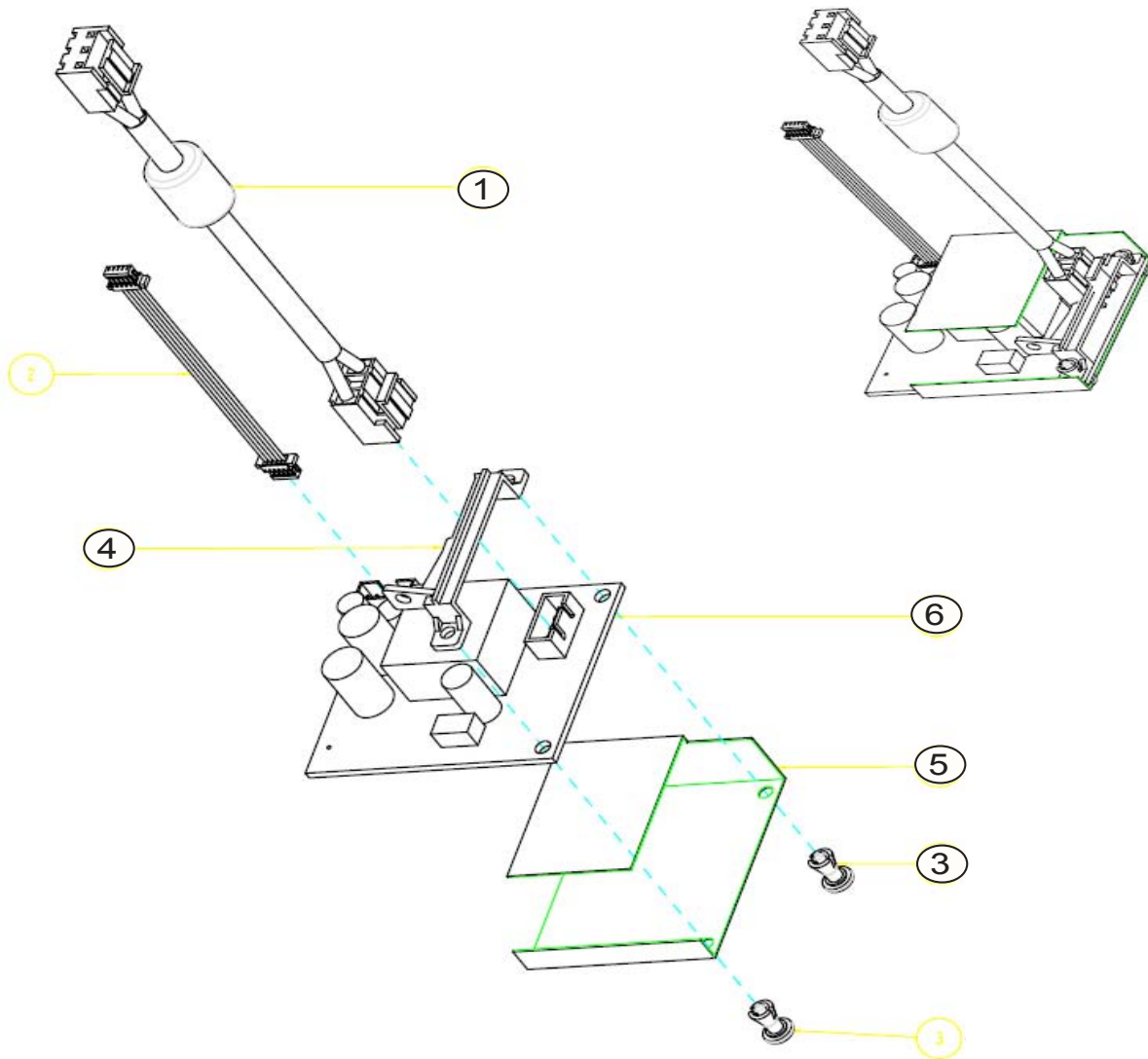

| ITEM | P/N | DECRPTION | Supply |
|------|--------------|---|--------|
| | 70.89Y28GR01 | ASSY DC-DC MODULE FOR P3150/P3250 (SERVICE) | |
| 1 | 42.004A1G001 | W.A.4P #24/#26 100mm DC.DC/BALLAST | |
| 2 | 42.004B1G001 | W.A. 5P #26 140mm DC-DC/MAIN BOARD M209X | |
| 3 | 51.00061G001 | PLASTIC RIVET E3.0 SR-3L"A0" | N |
| 4 | 51.89S17G001 | DC HOLDER PC M209X | N |
| 5 | 51.89S23G001 | DC-DC MYLAR M209X | N |
| 6 | 75.89S08G001 | ASSY MATRITEK D2D M209P | N |

ASSY LAMP HOUSING MODULE P3250

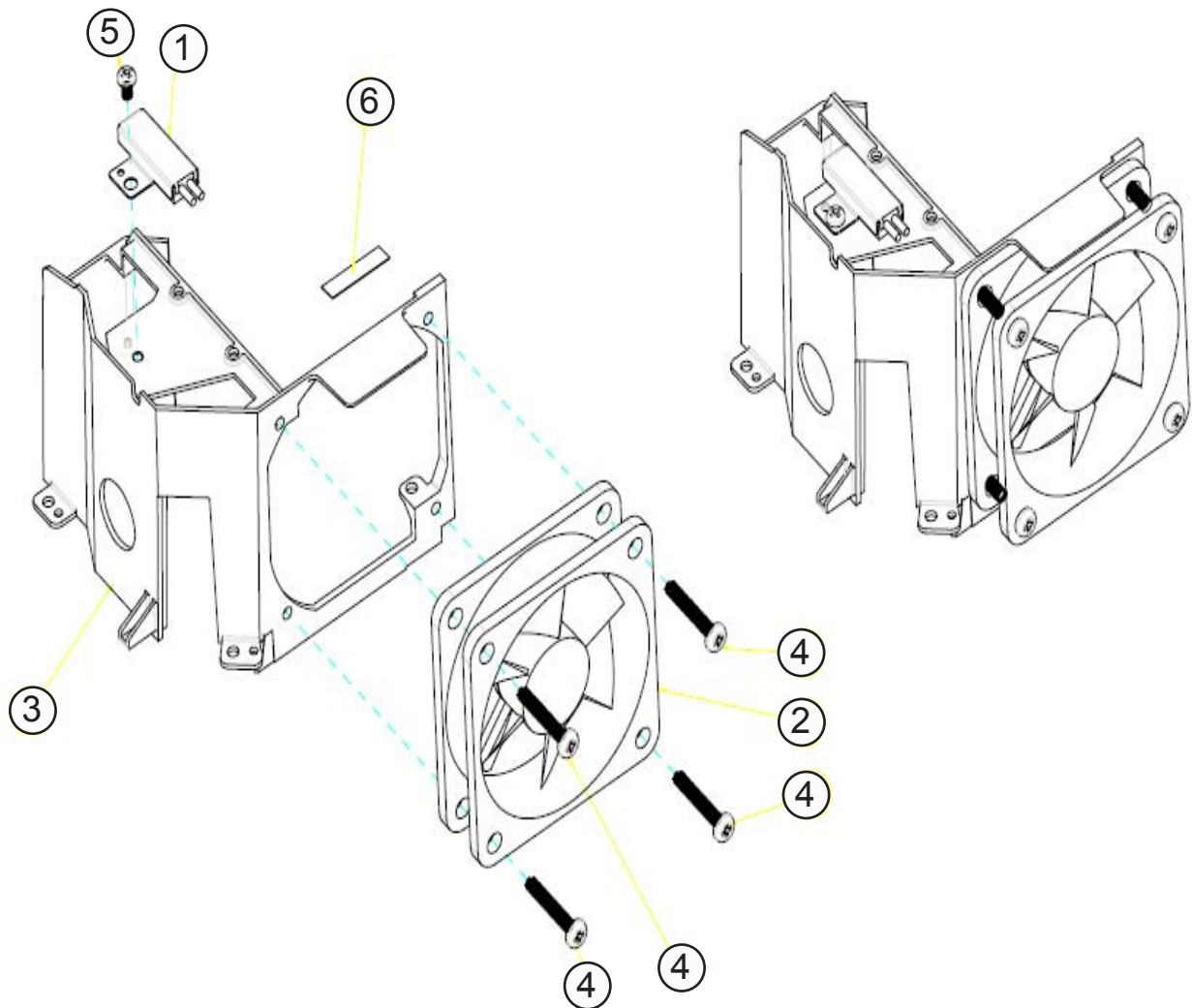

| ITEM | P/N | DECRPTION | Supply |
|------|--------------|--|--------|
| 1 | 43.89S01G001 | TH-RMAI SWITCH WITH BRACKET (KLIX-ON YSII) | |
| 2 | 49.85M03G001 | SYSTEM FAN/55*55*15mm | |
| 3 | 61.89Z06G001 | LAMP HOUSING MG ALLOY EX330 | N |
| 4 | 85.1A123G180 | SCREW PAN MECH M3*18 NI EP910 | N |
| 5 | 85.1A126G040 | SCREW PAN MECH M2.6*4 Ni | N |
| 6 | 41.89S03G001 | EMI TAPE W5*L25 H0.65 | N |

ASSY SPEAKER MODULE P3250

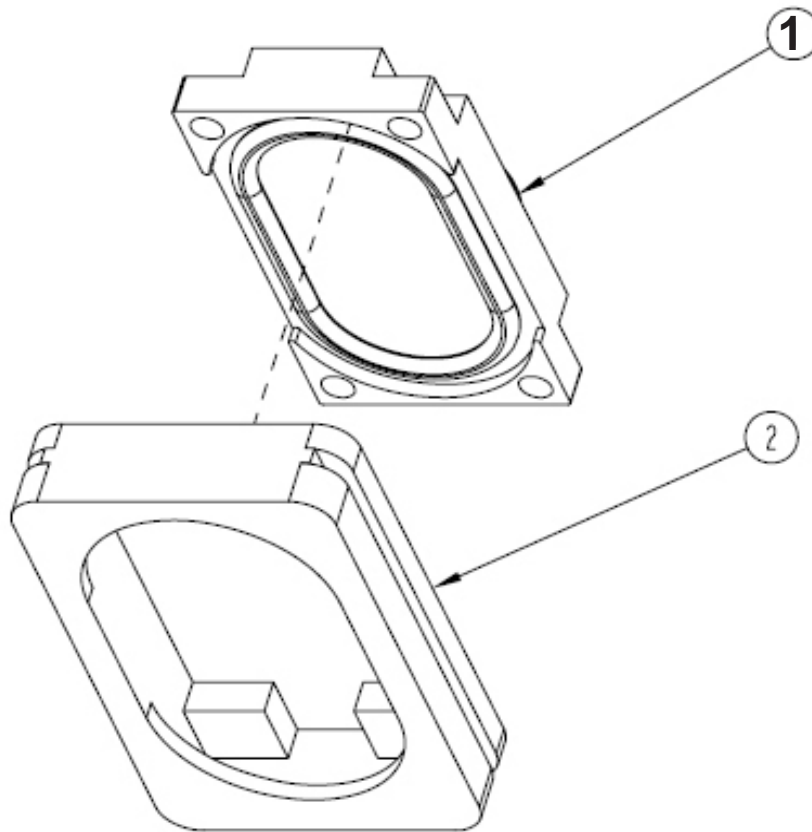

| ITEM | P/N | DECRPTION | Supply |
|------|--------------|------------------------------------|--------|
| 1 | 49.89Y01G001 | SPEAKER MINI IW 4 ohm 140 mm P3150 | |
| 2 | 52.89Y01G001 | SPEAKER RUBBER P3150 | N |

ASSY ENGINE MODULE P3250

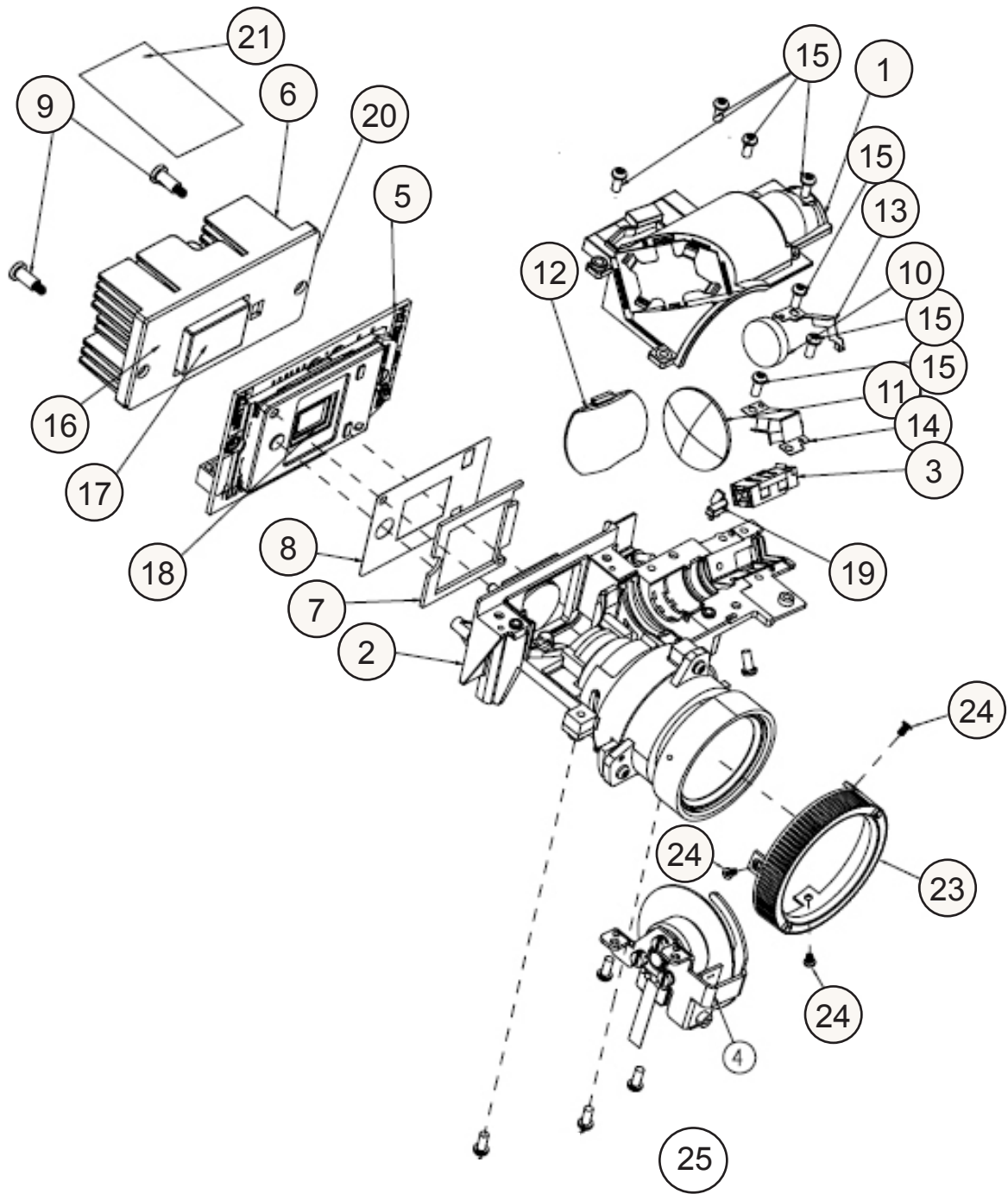

| ITEM | P/N | DESCRIPTION | Supply |
|------|--------------|---|--------|
| | 70.89Y22GR01 | ASSY ENGINE MODULE FOR P3150/ P3250(SERVICE) | |
| 1 | 70.89Y15G001 | ASSY ENGINE BOTTOM COVER P3150 | N |
| 2 | 70.89Y05G001 | ASSY ENGINE BASE MODULE P3150 | N |
| 3 | 70.89Y16G001 | ASSY ROD MODULE P3150 | N |
| 4 | 70.89Y21GR01 | ASSY COLOR WHEEL MODULE P3150 | |
| 5 | 80.89S02G001 | PCBA DMD BOARD FOR M209X | |
| 6 | 61.89S10G001 | DMD HEATSINK AL M209X | N |
| 7 | 52.88N04G002 | DMD RUBBER NEW 1.3T X15 | N |
| 8 | 61.88N15G001 | DMD MASK,SUS301,X15 | N |
| 9 | 85.4A826G118 | STEP SCREW FOR TYPEX DMD M2.6*11.8mm,X15 | |
| 10 | 23.88N20G001 | YO CONDENSER1 FOR X15 | N |
| 11 | 23.88N20G011 | YO CONDENSER2 FOR X15 | N |
| 12 | 23.88N06G011 | YO PLASTIC RELAY FOR X15 | N |
| 13 | 61.88N13G002 | ROD COVER NEW,SUS301,X15 | N |
| 14 | 61.88N12G001 | ROD SPRING,SUS301,X15 | N |
| 15 | 85.1A526G060 | SCREW PAN MECH M2.6*6 NI NYLOK | N |
| 16 | 52.88N03G002 | HEAT SINK RUBBER(X15) X1160 | N |
| 17 | 52.87J01G001 | DMD THERMAL PAD 25*17*0.5t FUJIPOLY SAR- GON GR-Hn | |
| 18 | 48.87M01G001 | DMD Type-X 1024x768 PIXEL 0.55" XGA LVDS | |
| 19 | 61.88N39G001 | STOP MASK MG X15 | N |
| 20 | 61.89Y06G001 | HEX SCREW M2.6*H6.8*L5, STEEL | N |
| 21 | 41.82K09G001 | EMI TAPE 30*50mm | N |
| 22 | 85.0A126G040 | SCREW DOUBLE FLAT MECH M2.6*4Ni | N |
| 23 | 51.89Y05G001 | FOCUS RING P3150 | |
| 24 | 85.WA321G040 | SCREW PAN TAP M1.7*4 BLACK | N |
| 25 | 80.88N04G001 | PCBA PHOTO SENSOR BOARD FOR EP721 | |

AK. P3250

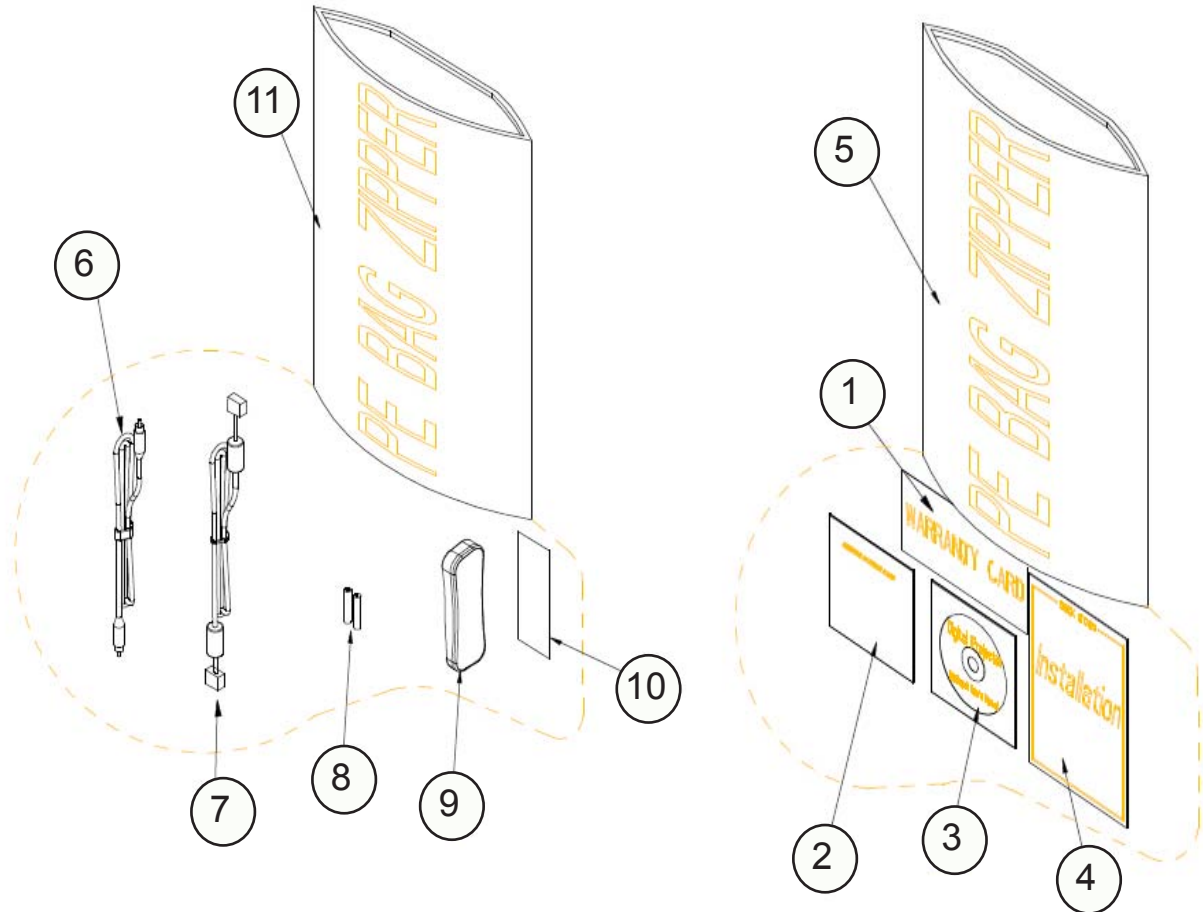

| ITEM | P/N | DESCRIPTION | Supply |
|------|--------------|--------------------------------|--------|
| 1 | 36.00006G031 | WARRANTY CARD ,EUROPE FOR ACER | N |
| 2 | 36.00027G001 | SERVICE STATION CARD | N |
| 3 | 36.89Y01G001 | USER'S GUIDE MULTILINGUAL (C | N |
| 4 | 36.89Y02G001 | QUICK START CARD MULTILINGUA | N |
| 5 | 51.86213G002 | PE BAG ZIPPER #9 W/RECYCLING M | N |
| 6 | 42.00232G001 | CABLE COMPOSITE VIDEO 2M YELLO | N |
| 7 | 42.83M09G101 | CABLE MINI JACK TO MINI JACK | N |
| 8 | 46.82V02G001 | BATTERY #4 1.5V R04 PD120 | N |
| 9 | 45.87U01G106 | INFRARED REMOTE CONTROLLER L | |
| 10 | 36.00029G001 | SECURITY CARD FOR ACER | N |
| 11 | 51.86213G002 | PE BAG ZIPPER #9 W/RECYCLING M | N |

DP. P3250

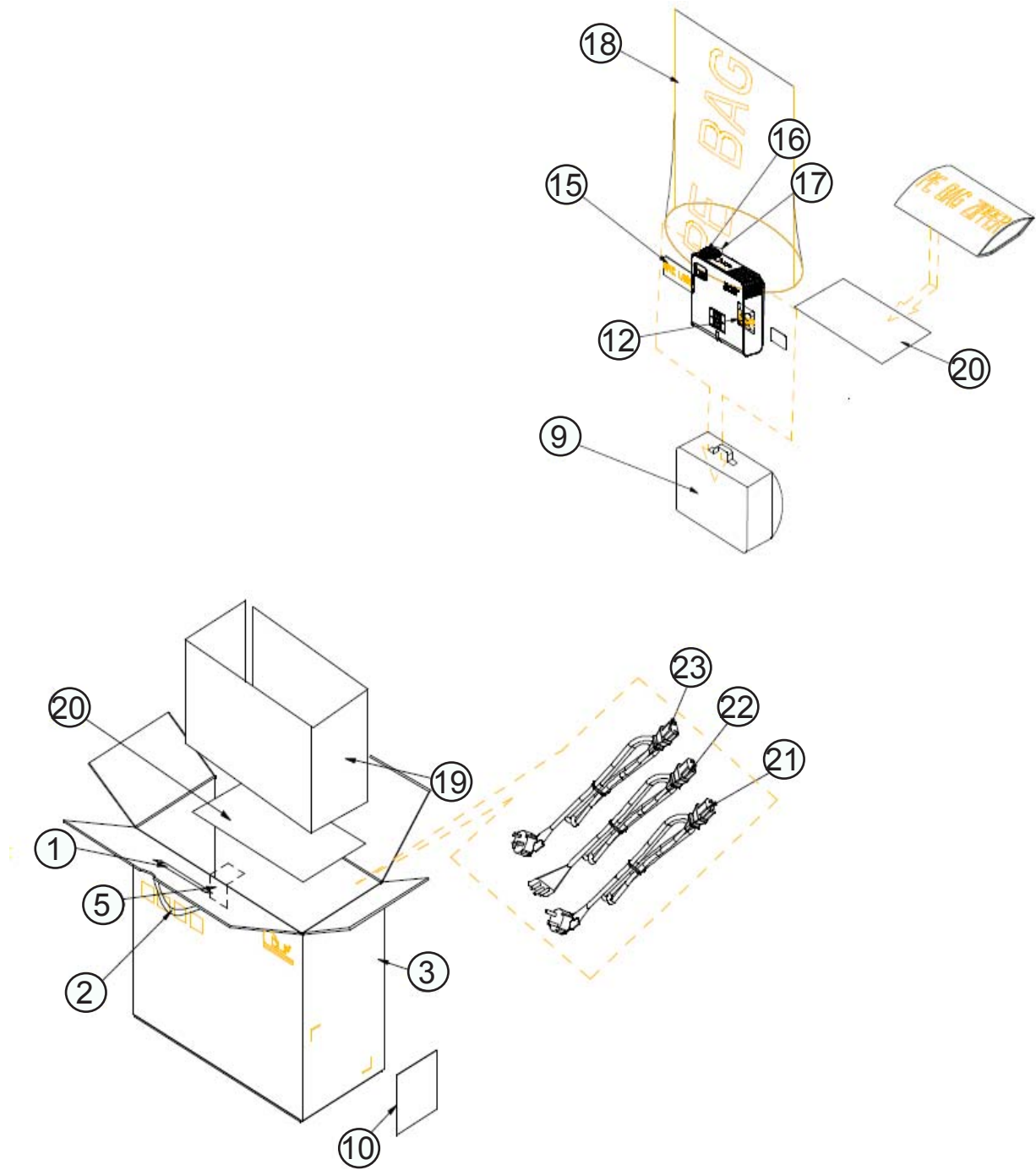

| ITEM | P/N | DESCRIPTION | Supply |
|------|--------------|---|--------|
| 1 | 51.00201G001 | HANDLE BAR 1.PE HD70 | N |
| 2 | 51.00200G001 | HANDLE BAR 2. PE HD70 | N |
| 3 | 55.89Y01G001 | CARTON CARRY BOX P3150 | N |
| 4 | 55.89Y02G001 | CENTER PAPER BOX P3150 | N |
| 5 | 35.82L04G001 | ACER TAPE 45M FOR CARTON | N |
| 6 | 55.87W04G001 | CORNER PAPER P5271 | N |
| 7 | 58.86202GC02 | COVER PALLET 1150*970mm FOR 34 | N |
| 8 | 58.86201GC02 | WOOD PALLET 48"*40*5"(DOUBLE F | N |
| 9 | 53.89Y01G001 | SOFT CARRY BAG P3150 | N |
| 10 | 35.52302G091 | LABEL CARTON 108*92 BLANK | N |
| 11 | 55.87202G001 | BOTTOM PAPER COVER PLATE 1230* | N |
| 12 | 57.00001G001 | PACK SIO2 DRIER 20g | N |
| 13 | 35.82L04G001 | LAMP WARNING LABEL ARES A | N |
| 14 | 35.82V02G001 | LABEL CARTON(SEAL) 110*50mm PD | N |
| 15 | 35.85M02G001 | SPEC LABEL PD311 | N |
| 16 | 52.89Y04G002 | LENS-CAP FOR P3150 | N |
| 17 | 51.89Y16G001 | LENS CAP STRAP P3150 | N |
| 18 | 51.00174G002 | PE BAG 380*310*0.07mm FOR OP | N |
| 19 | 56.89Z01G001 | AIR BAG RIM EX330 | N |
| 20 | 56.89Z02G001 | AIR BAG TOP/BOTTOM EX330 | N |
| 21 | 42.00120G011 | CABLE POWER CORD 1.8M SP-023/IS-14 EUROPE DIS-WARNING LABEL | |
| 22 | 42.00110G011 | CABLE POWER CORD 1.8M SP-60/IS-14 UK DIS-WARNING LABEL | |
| 23 | 42.00131G011 | CABLE POWER CORD 1.8M SP-027/IS-14 SWITZERLAND DIS-WARNING LABEL | |

Appendix B

I. Serial Number System Definition

Serial Number Format for Projector(for non-refresh models,take P3150 for example)

EYJ6701W02 811 00000 59 00

① ② ③ ④ ⑤

① : EYJ6701W02 = Part Number excluded “dot”

② : 811 = Week Code(ex:2008 = 8,the eleven weeks of the year = 11)

③ : 00000 = Serial Numbers

④ : 59 = Manufacturing Code

⑤ : 00 = Projector. Version

EX: EYJ6701W02811000005900

This label represents the serial number for P3150. It is produced for Europe at CPC on eleven week of 2008. Its serial code is 00000.

Serial Number Format for Projector(for refresh models,take P3150refresh for example)

EYJ8401006 829 00000 59 0 1

① ② ③ ④ ⑤ ⑥

① : **EYJ8401006 = Part Number excluded “dot”**

② : **829 = Week Code(ex:2008 = 8 twenty-nine weeks of the year = 29)**

③ : **00000 = Serial Numbers**

④ : **59 = Manufacturing Code**

⑤ : **0 = Projector. Version**

⑥ : **1 = Default Language Information**

EX: EYJ8401006829000005901

This label represents the serial number for P3150 refresh. It is produced for Europe at CPC on twenty-nine week of 2008. Its serial code is 00000.

Note: About the discrimination between refresh model and non refresh model, please refer to RM-P-A08015.

II. PCBA Code Definition

PCBA Code for Projector

A **B** **XXX** **XXXXXXXXXX** **CC** **XXX** **EEEE**
① ② ③ ④ ⑤ ⑥ ⑦

- ① : ID
- ② : Vendor Code
- ③ : Firmware Version
- ④ : P/N
- ⑤ : MB Version
- ⑥ : Date Code
- ⑦ : S/N

Free Manuals Download Website

<http://myh66.com>

<http://usermanuals.us>

<http://www.somanuals.com>

<http://www.4manuals.cc>

<http://www.manual-lib.com>

<http://www.404manual.com>

<http://www.luxmanual.com>

<http://aubethermostatmanual.com>

Golf course search by state

<http://golfingnear.com>

Email search by domain

<http://emailbydomain.com>

Auto manuals search

<http://auto.somanuals.com>

TV manuals search

<http://tv.somanuals.com>