

Agilent E5250A Low Leakage Switch Mainframe

User's Guide



Notices

© Agilent Technologies 1995 - 2005

No part of this manual may be reproduced in any form or by any means (including electronic storage and retrieval or translation into a foreign language) without prior agreement and written consent from Agilent Technologies, Inc. as governed by United States and international copyright laws.

Manual Part Number

E5250-90006

Edition

Edition 1, October 1995

Edition 2, January 1997

Edition 3, August 1997

Edition 4, January 2000

Edition 5, May 2000

Edition 6, January 2001

Edition 7, August 2003

Edition 8, July 2005

Agilent Technologies, Inc.
395 Page Mill Road
Palo Alto, CA 94303 USA

Warranty

The material contained in this document is provided “as is,” and is subject to being changed, without notice, in future editions. Further, to the maximum extent permitted by applicable law, Agilent disclaims all warranties, either express or implied, with regard to this manual and any information contained herein, including but not limited to the implied warranties of merchantability and fitness for a particular purpose. Agilent shall not be liable for errors or for incidental or consequential damages in connection with the furnishing, use, or performance of this document or of any information contained herein. Should Agilent and the user have a separate written agreement with warranty terms covering the material in this document that conflict with these terms, the warranty terms in the separate agreement shall control.

Technology Licenses

The hardware and/or software described in this document are furnished under a license and may be used or copied only in accordance with the terms of such license.

Restricted Rights Legend

If software is for use in the performance of a U.S. Government prime contract or subcontract, Software is delivered and licensed as “Commercial computer software” as defined in DFAR 252.227-7014 (June 1995), or as a “commercial item” as defined in FAR 2.101(a) or as “Restricted computer software” as defined in FAR 52.227-19 (June 1987) or any equivalent agency regulation or contract clause. Use, duplication or disclosure of Software is subject to Agilent Technologies’ standard commercial license terms, and non-DOD Departments and Agencies of the U.S. Government will receive no greater than Restricted Rights as

defined in FAR 52.227-19(c)(1-2) (June 1987). U.S. Government users will receive no greater than Limited Rights as defined in FAR 52.227-14 (June 1987) or DFAR 252.227-7015 (b)(2) (November 1995), as applicable in any technical data.

DECLARATION OF CONFORMITY
According to ISO/IEC Guide 22 and CEN/CENELEC EN 45014

Manufacturer's Name: Agilent Technologies Japan, Ltd.

Manufacturer's Address: Hachioji Semiconductor Test Division
9-1, Takakura-cho, Hachioji-shi
Tokyo, 192-8510 Japan

Declares, that the product

Product Name: Low Leakage Switch Mainframe
10x12 Matrix Switch
24(8x3)CH Multiplexer
Model Number: Agilent E5250A /Agilent E5252A /Agilent E5255A
Product Options: This declaration covers all options of the above product.

Conforms to the following directives and carries the CE marking accordingly:

EMC Directive 89/336/EEC
Standards referenced:

IEC 61326-1:1997+A1:1998 / EN 61326-1:1997+A1:1998
CISPR 11:1990 / EN 55011-1991
IEC 61000-4-2:1995+A1:1998 / EN 61000-4-2:1995
IEC 61000-4-3:1995 / EN 61000-4-3:1996
IEC 61000-4-4:1995 / EN 61000-4-4:1995
IEC 61000-4-5:1995 / EN 61000-4-5:1995
IEC 61000-4-6:1996 / EN 61000-4-6:1996
IEC 61000-4-11:1994 / EN 61000-4-11:1994

Supplemental Information:
Australia/New Zealand: AS/NZS 2064.1

Limit

Group 1, Class A ^[1]
4 kV CD, 8 kV AD
3 V/m, 80 - 1000 MHz
0.5 kV sig. lines, 1 kV power lines
0.5 kV L-L, 1 kV L-G
3 V, 0.15 - 80 MHz
1 cycle, 100%

^[1] The product was tested in a typical configuration with Agilent Technologies test systems.

Safety Low Voltage Directive 73/23/EEC
Standards:

IEC 61010-1:1990+A1:1992+A2:1995 / EN 61010-1:1994+A2:1995
CSA-C22.2 No. 1010.1-1992, NRTL/C

Date: May 28, 2001

Toshiyuki Kawaji

川路 利行

QA Manager

For further information, please contact your local Agilent Technologies sales office, agent or distributor.

Rev. B (6/2000)

- **Herstellerbescheinigung**

GEÄUSCHEMISSION

Lpa < 70 dB

am Arbeitsplatz

normaler Betrieb

nach DIN 45635 T. 19

- **Manufacturer's Declaration**

ACOUSTIC NOISE EMISSION

Lpa < 70 dB

operator position

normal operation

per ISO 7779

NOTE

This ISM device complies with Canadian ICES-001.

Cet appareil ISM est conforme ?Hla norme NMB-001 du Canada.



This product complies with the WEEE Directive (2002/96/EC) marking requirements. The affixed label indicates that you must not discard this electrical/electronic product in domestic household waste.

Product Category: With reference to the equipment types in the WEEE Directive Annex I, this product is classed as a “Monitoring and Control instrumentation” product.

Do not dispose in domestic household waste.

To return unwanted products, contact your local Agilent office, or see www.agilent.com/environment/product/ for more information.

Microsoft, Windows, Windows NT, Visual C++, and Visual Basic are registered trademarks of Microsoft Corporation. Borland C++ Builder is registered trademark of International, Inc. LabWindows and LabVIEW are registered trademarks of National Instruments Corporation.

Safety Summary

The following general safety precautions must be observed during all phases of operation, service, and repair of this instrument. Failure to comply with these precautions or with specific warnings elsewhere in this manual may impair the protections provided by the equipment. In addition, it violates safety standards of design, manufacture, and intended use of the instrument. Agilent Technologies, Inc. assumes no liability for customer's failure to comply with these requirements.

NOTE

Agilent E5250A complies with INSTALLATION CATEGORY II for mains input and INSTALLATION CATEGORY I for measurement input terminals, and POLLUTION DEGREE 2 defined in IEC 1010-1.

Agilent E5250A is INDOOR USE products.

- *GROUND THE INSTRUMENT*

This is Safety Class I instrument. To minimize shock hazard, the instrument chassis and cabinet must be connected to an electrical ground. The power terminal and the power cable must meet International Electrotechnical Commission (IEC) safety standards.

- *DO NOT OPERATE IN AN EXPLOSIVE ATMOSPHERE*

Do not operate the instrument in the presence of flammable gases or fumes. Operation of any electrical instrument in such an environment constitutes a definite safety hazard.

- *KEEP AWAY FROM LIVE CIRCUITS*

Operation personnel must not remove instrument covers. Component replacement and internal adjustments must be made by qualified maintenance personnel. Do not replace components with power cable connected. Under certain conditions, dangerous voltages may exist even with the power cable removed. To avoid injuries, always disconnect power and discharge circuits before touching them.

- *DO NOT SERVICE OR ADJUST ALONE*

Do not attempt internal service or adjustment unless another person, capable of rendering first aid and resuscitation, is present.

- *DO NOT SUBSTITUTE PARTS OR MODIFY INSTRUMENT*

Because of the danger of introducing additional hazards, do not install substitute parts or perform any unauthorized modification to the instrument. Return the instrument to a Agilent Technologies Sales and Service Office for services and repair to ensure that safety features are maintained.

- *DANGEROUS PROCEDURE WARNINGS*

Warnings, such as example below, precede potentially dangerous procedures throughout this manual. Instructions contained in the warnings must be followed.

WARNING

Dangerous Voltage, capable of causing death, are present in this instrument. Use extreme caution when handling, testing, and adjusting.

Safety Symbols

The general definitions of safety symbols used on equipment or in manuals are listed below.



Instruction manual symbol: the product will be marked with this symbol when it is necessary for the user to refer to the instruction manual in order to protect against damage to the instrument.



Indicates dangerous voltage and potential for electrical shock. Do not touch terminals that have this symbol when instrument is on.



Affixed to product containing static sensitive devices--use anti-static handling procedures to prevent electrostatic discharge damage to component.



Protective conductor terminal. For protection against electrical shock in case of a fault. Used with field wiring terminals to indicate the terminal which must be connected to ground before operating equipment.



Frame or chassis terminal. A connection to the frame (chassis) of the equipment which normally includes all exposed metal structures.



Indicates earth (ground) terminal.



Alternating current.



Direct current.



ON (Supply).



OFF (Supply).



STANDBY (Supply).

CAT 1

Means INSTALLATION CATEGORY I. Measurement terminals on the rear panel comply with INSTALLATION CATEGORY I.

WARNING

The warning sign denotes a hazard. It calls attention to a procedure, practice, condition or the like, which, if not correctly performed or adhered to, could result in injury or death to personal.

CAUTION

The caution sign denotes a hazard. It calls attention to an operating procedure, practice, condition or the like, which, if not correctly performed or adhered to, could result in damage to or destruction of part or all of the product.

In This Manual

This manual is a user's guide for Agilent E5250A, and consists of the following chapters:

- **Introduction**

Provides an overview of the E5250A Low Leakage Switch Mainframe, E5252A 10×12 Matrix Switch, and E5255A 24 (8×3) Channel Multiplexer.
- **Installation**

Describes requirements to install the E5250A and tasks for installation.
- **Executing Self-Test and Leak Test**

Describes how to execute the three Self-Test items (Controller Test, Front Panel Interface Test, and Relay Test) and the Leak Test.
- **Setting up Measurement Environment**

Explains how to connect your instruments to the E5250A input, and how to connect the E5250A output to your wafer prober or test fixture.
- **Controlling the E5250A**

Introduces several methods for controlling the E5250A, gives basic information for controlling the relay switches on the plug-in cards, and describes how to use Virtual Front Panel (VFP) utility furnished with the E5250A.
- **Programming the E5250A**

Describes how to create programs that contain SCPI commands to control the E5250A.
- **Command Reference**

Describes the SCPI commands available to operate the E5250A via GPIB interface and the status reporting structure.
- **VXI plug&play Driver**

Introduces the VXI plug&play driver available for the E5250A.
- **Executing Sample Programs**

Explains how to execute and modify the sample programs stored in the program disk that is furnished with the E5250A.

- **Specifications**
Lists specifications, typical data, supplemental data, and reference data for the E5250A, E5252A, and E5255A.
- **Error Messages**
Lists and describes the error messages for the E5250A.
- **SCPI Command Summary**
This is a quick reference for the SCPI subsystem commands available for the E5250A.



Text Conventions

The following text conventions are used in this manual:





- | | |
|--------------------------|---|
| <code>Screen Text</code> | Represents text that appears on screen of the controller. |
| <i>Italic</i> | Refers to a related document, or is used for emphasis. |

Contents

1. Introduction

Agilent E5250A Product Description	1-3
Front Panel Tour	1-4
Rear Panel Tour	1-4
	1-5
Agilent E5252A Product Description	1-6
	1-7
Agilent E5255A Product Description	1-8
	1-11
Options and Accessories	1-12

2. Installation

	2-2
To Inspect the E5250A and Accessories	2-3
Requirements	2-4
Power Requirements	2-4
Power Cable	2-4
Operating Environment	2-6
Storage and Shipping Environment	2-6
Installing the E5250A	2-7
	2-7
To Install Plug-in Card	2-8
To Install Blank Panel	2-9
To Configure E5255A	2-10
	2-11
	2-12
E5255A Configuration Examples	2-13
To Set GPIB Address	2-17
To Connect GPIB Cable	2-17

Contents

Maintenance	2-18
Performance Verification	2-18
Cleaning	2-18
3. Executing Self-Test and Leak Test	
Executing Self-Test	3-3
To Execute Self-Test (Standalone)	3-4
To Execute Self-Test using External Controller	3-6
Using the Self-Test Utility	3-10
Requirements	3-10
To Start the Self-Test Utility	3-11
To Execute Self-Test	3-12
To Execute Leak Test	3-15
4. Setting up Measurement Environment	
Connector Plates	4-3
Connector Plates for the E5252A	4-3
Connector Plates for E5255A	4-3
Blank Plate	4-4
Connecting 8-Channel Shielded Coaxial Cable	4-5
⚠	4-5
Mounting Connectors Directly	4-6
To Make Interlock Circuit	4-8
To Connect Connectors to DUT	4-13
Connecting the E5250A Input	4-15
To Connect Instruments to Input Connectors	4-15
To Connect Bias Source to the E5255A Bias Input	4-18
To Connect GNDU to the E5250A Input	4-18
Connecting the E5250A Output	4-20

Contents

To Connect the E5252A Output	4-20
To Connect the E5255A Output	4-22
Measurement Cable Length	4-23

5. Controlling the E5250A

Methods for Controlling the E5250A	5-3
Creating Your Own Program	5-3
Modifying a Sample Program	5-4
Using the Virtual Front Panel (VFP) Utility	5-4
Switch Control Basics	5-5
Channel List and Channel Configuration	5-6
Connection Rule	5-9
Connection Sequence	5-10
Bias Mode	5-11
Couple Port	5-13
E5252A Channel List	5-15
E5255A Channel List	5-19
Using Virtual Front Panel Utility	5-25
Functions of Virtual Front Panel Utility	5-26
Requirements	5-27
Starting the Virtual Front Panel Utility	5-27
Confirming the E5250A Card Configurations	5-28
Changing the VFP Setup Mode	5-29
Defining Labels for the E5250A Input Ports	5-31
Making Connections and Changing the Setup Data	5-33
Saving/Loading the Setup Data	5-42

6. Programming the E5250A

SCPI Programming Basics	6-3
SCPI Command Hierarchy	6-4

Contents

Controlling E5250A by Using HP BASIC	6-5
Creating a Control Program	6-6
Defining Channel Configuration Mode	6-8
Defining Connection Rule	6-8
Defining Connection Sequence	6-9
Using Bias Mode	6-10
Using Couple Port (for E5252A only)	6-11
Controlling Relay Switching	6-12
Programming Examples	6-13
Channel Creation Example	6-14
Bias Mode Example	6-16
Couple Port Example	6-19
Using the VFP Data Upload Library	6-22
VFP Data Upload Library	6-23
Programming Example	6-25
Before Executing Your Program	6-26
Error Messages	6-27
Using the Capacitance Compensation Routine	6-28
Capacitance Compensation Routine	6-29
Required Conditions	6-30
Programming Example	6-32
Before Executing Your Program	6-32
Error Messages	6-32
7. Command Reference	
Common Commands	7-4
:DIAGnostic Subsystem	7-15
:ROUTe Subsystem	7-20
:SYSTEM Subsystem	7-42

Contents

Status Reporting Structure	7-48
Status Reporting Structure	7-48
Status Byte Register	7-50
Service Request Enable Register	7-52
Standard Event Status Register	7-53
Standard Event Status Enable Register	7-54
Output Queue	7-55
8. VXI plug&play Driver	
System Requirements	8-3
Installing VXI <i>plug&play</i> Driver	8-4
Driver Functions	8-5
9. Executing Sample Programs	
Vth and Capacitance Measurement Program	9-3
Introduction	9-3
Setting up the Measurement Environment	9-7
Executing the Program	9-9
Modifying the Program	9-11
HCI Measurement Program	9-17
Introduction	9-17
Adding the Bias Source Control Routine	9-23
Setting up the Measurement Environment	9-24
Executing the Program	9-27
Modifying the Program	9-35
10. Specifications	
11. Error Messages	

Contents

12. SCPI Command Summary

1 Introduction

Introduction

This chapter gives an overview of Agilent E5250A, E5252A, and E5255A.

- “Agilent E5250A Product Description”
- “Agilent E5252A Product Description”
- “Agilent E5255A Product Description”
- “Options and Accessories”

Agilent E5250A Product Description

Agilent E5250A Low Leakage Switch Mainframe is a computer-controlled switching matrix mainframe designed for semiconductor dc characteristics measurement applications. The E5250A has four slots for installing the modules (plug-in cards) listed in Table 1-1.

These cards can be used in various switching matrix configurations in the E5250A. For example, using four E5252As, you can configure a maximum 10-input 48-output switching matrix, or using four E5255As, you can configure a maximum 2-input \times 96-output multiplexer.

Table 1-1

Available Plug-in Cards for E5250A

Model No.	Description
E5252A	10 \times 12 Matrix Switch
E5255A	24 (8 \times 3) Channel Multiplexer

Figure 1-1

E5250A Front Panel

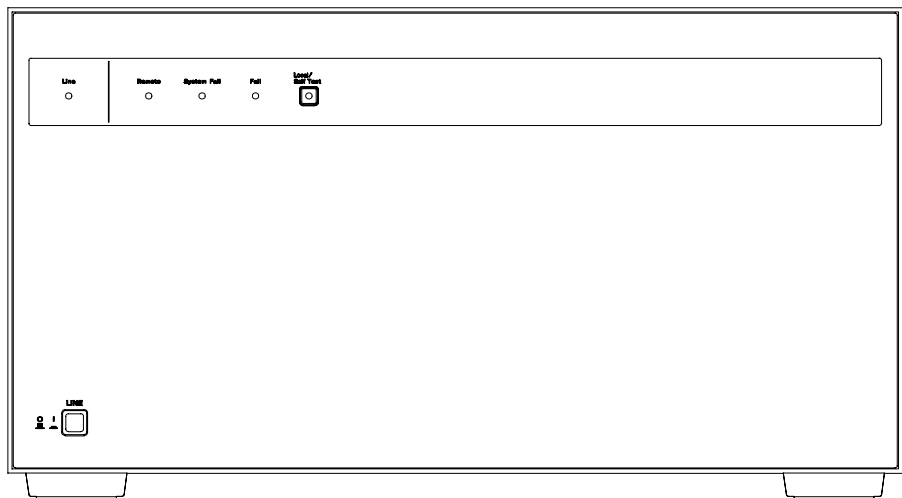

Front Panel Tour

The E5250A has 2 hard keys and 4 LED indicators on the front panel as shown in Figure 1-1.

LINE key	Used to turn the E5250A on or off.
Line LED	Turns on when the E5250A is turned on.
Local/Self Test key	<p>If "Remote" LED is on, pressing this key releases the E5250A from remote GPIB control by an external controller.</p> <p>If "Remote" LED is off, pressing this key executes the Relay Test. Before pressing this key, make sure the Relay Test Adapter is connected. For details of Relay Test, refer to Chapter 3. During Relay Test execution, the LED in this key is ON.</p>
Remote LED	Turns on when the E5250A is in the GPIB remote status.
System Fail LED	Turns on if system error occurs in the E5250A. Contact your nearest Agilent Technologies Service Center.
Fail LED	Turns on if the E5250A fails Self-test (including Relay Test). If this LED turns on after executing Relay Test, a plug-in card may be defective. And if this LED turns on after turning the E5250A on again, the E5250A is defective. If so, contact your nearest Agilent Technologies Service Center.

Rear Panel Tour

Rear panel of the E5250A is shown in Figure 1-2. The E5250A has 4 slots for installing plug-in cards, and 10 input connectors for connecting measurement cables from instruments.

SMU INPUT	<p>SMU INPUT connectors are for semiconductor dc characteristics measurements.</p> <p>The E5250A has six SMU INPUT ports, which are triaxial type connectors. The connectors can also be used for a maximum three Kelvin connection inputs by coupling two ports as follows:</p> <ul style="list-style-type: none">• SMU INPUT 1 and 2• SMU INPUT 3 and 4• SMU INPUT 5 and 6
------------------	--

AUX INPUT

AUX INPUT connectors are for C-V measurements, pulse input, and so on.

The E5250A has 4 AUX INPUT ports: HF1, HF2, CV1, CV2. These are BNC type connectors.

The AUX INPUT connectors are used only with the E5252A and are not used with the E5255A.

CAUTION 

The maximum measurement voltage that can be applied to any input terminal is ± 200 Vdc. The maximum measurement current is 1 Adc at ± 200 Vdc. The maximum voltage that can be applied between input terminals is 300 Vdc. Do not apply an input signal over these limits to the E5250A inputs. If you do, the E5250A will be damaged.

If you use a bias source that has current limit capability, set the bias source current limit to less than 1 Adc.

Figure 1-2 E5250A Rear Panel

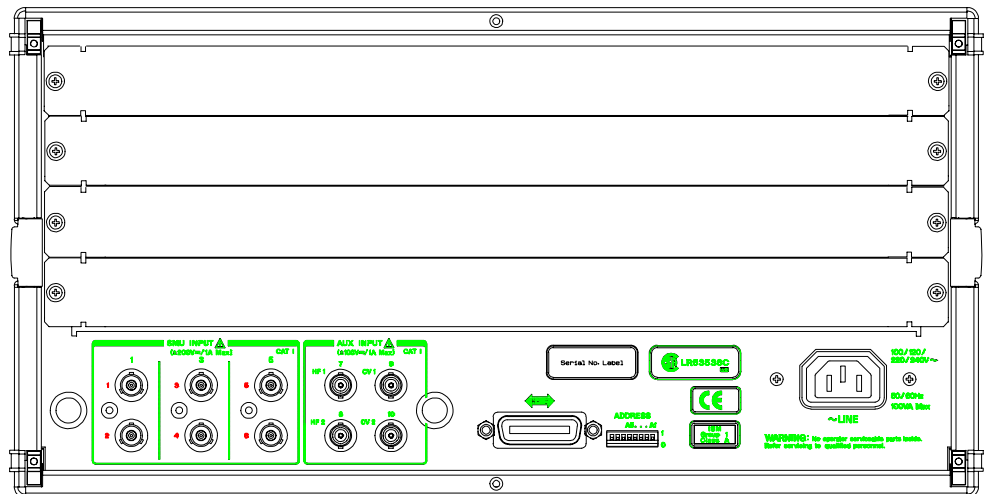

Agilent E5252A Product Description

The E5252A 10×12 Matrix Switch is a 10-input to 12-output switching matrix card for the E5250A. The E5252A is designed for semiconductor dc parametric measurement applications that need to switch some instruments connected to Device Under Test (DUT), or need to scan instrument input/output for many DUTs, automatically.

The E5250A can be installed with maximum four E5252As. And the input terminals of the E5252As are connected together inside the E5250A. So, the E5250A can configure a 10×24 matrix (two E5252As), 10×36 matrix (three E5252As), and 10×48 matrix (four E5252As). The E5252A block diagram and output connectors are shown in Figure 1-3 and Figure 1-4.

Figure 1-3 E5252A Block Diagram

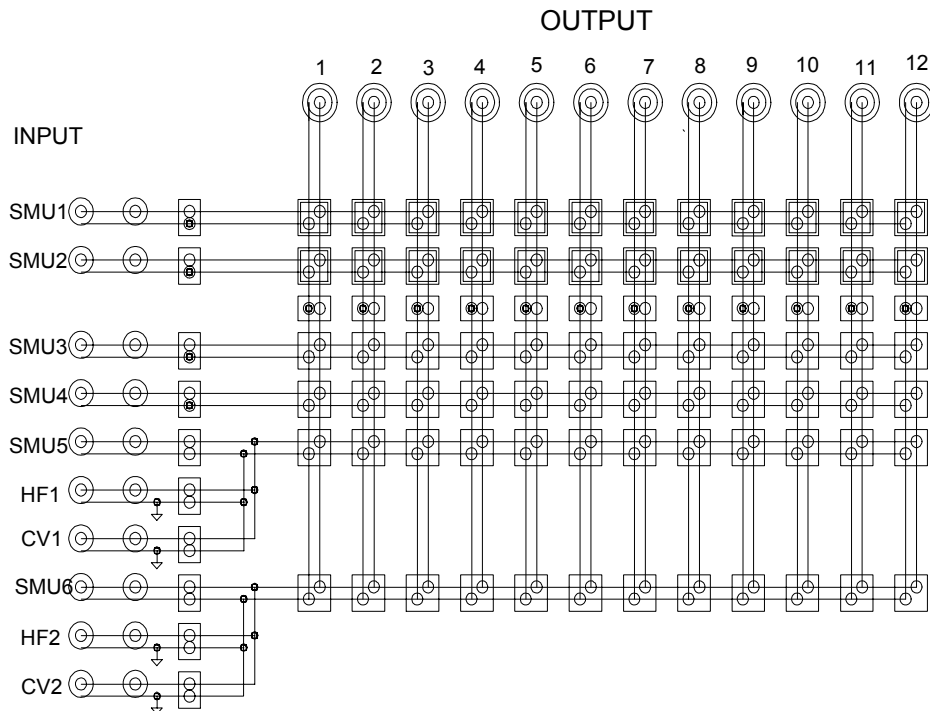

Input Ports

The E5252A has 10 input ports via the E5250A.

Input paths for SMU1 and SMU2 are designed for low current measurement.

There are actually only six input paths, so two of the input paths are shared by three ports each as follows:

- SMU5, HF1, and CV1 ports share same input path
- SMU6, HF2, and CV2 ports share same input path

So, for these two input paths, you can only use one input port at a time. For example, you *cannot* use HF1 and CV1 input ports at the same time.

Output Ports

The E5252A has 12 output ports. Two ports can be coupled for Kelvin connection output for a maximum of six Kelvin outputs:

- OUTPUT1 and OUTPUT2
- OUTPUT3 and OUTPUT4
- OUTPUT5 and OUTPUT6
- OUTPUT7 and OUTPUT8
- OUTPUT9 and OUTPUT10
- OUTPUT11 and OUTPUT12

The output ports are triaxial connectors.

Figure 1-4 E5252A Output Ports

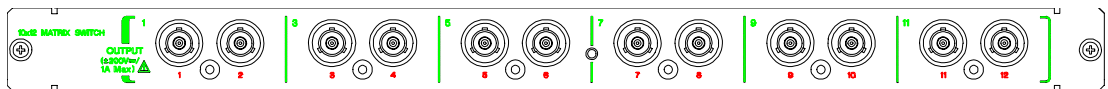

WARNING

Do not touch the force and guard terminals of the output connectors while the E5250A is turned on. Dangerous voltages up to the maximum input voltage may be present at the output connectors.

Agilent E5255A Product Description

The E5255A 24 (8×3) Channel Multiplexer is a 2-input to 24-output multiplexer card for the E5250A. The E5255A consists of 3 blocks (three 2×8 multiplexers). So, one E5255A can be configured as a 2×8 multiplexer, 2×16 multiplexer, or 2×24 multiplexer. "2-input" means one BIAS input and one IV input.

The E5255A is designed for semiconductor device reliability testing which needs to automatically scan instrument input/output for many DUTs.

A maximum of four E5255As can be installed in the E5250A, which can use the multiplexers in several configurations. For example, the E5250A can configure twelve 8-output multiplexers, six 16-output multiplexers, four 24-output multiplexers, three 32-output multiplexers, two 48-output multiplexers, or one 96-output multiplexer.

The E5255A block diagram is shown in Figure 1-5.

BIAS Input The BIAS INPUT ports are used to apply ac or dc bias to DUT. BIAS INPUT ports are BNC connectors. Each BIAS INPUT port is assigned to a 2×8 multiplexer block as shown in Table 1-2. And you can make internal connections to connect a BIAS INPUT port to multiple blocks. Refer to Chapter 2.

IV Input IV input is used for measuring/forcing dc current/voltage. You can connect the IV input to desired SMU INPUT connector (SMU1 to SMU6) of the E5250A by making an internal connection. Refer to Chapter 2. The E5250A AUX INPUT connectors are not used with the E5255A.

OUTPUT Connectors The E5255A has three 8-channel coaxial output connectors as shown in Figure 1-6. Each output connector is assigned to a 2×8 multiplexer as shown in Table 1-2.

Resistors

Resistors connected between BIAS path and IV path are for protecting DUT from electrical damage. When shipped from factory, 0 Ω resistance is used in the E5255A. You can easily replace with desired resistors. Refer to Chapter 2. The following resistors are furnished with the E5255A:

- 0 Ω resistors (3 sets with 10 resistors in each set)
- 1.2 k Ω resistors (3 sets with 10 resistors in each set)
- 22 k Ω resistors (3 sets with 10 resistors in each set)

If you replace initial 0 Ω resistors with other resistors, you must cut the initial resistors. Then, if you need 0 Ω resistors again, use the ones listed above.

WARNING

Be careful about the following when selecting protective resistors:

- **If only one E5255A is installed in the mainframe, total power consumption by resistors must be less than 16W.**
- **If multiple E5255As are installed in the mainframe, total power consumption by resistors must be less than 32W.**
- **Consider the current flows to resistor when DUT shorts, and make sure the power consumption by resistor will be within specification of resistor.**

Do not use resistors that have specifications inadequate for your applications, which will result in resistors heating up, burning, or smoking.

Be careful about the heating of the rear panel of mainframe or plug-in card, which may be heated by resistors, even if you follow this warning.

Figure 1-5

E5255A Block Diagram

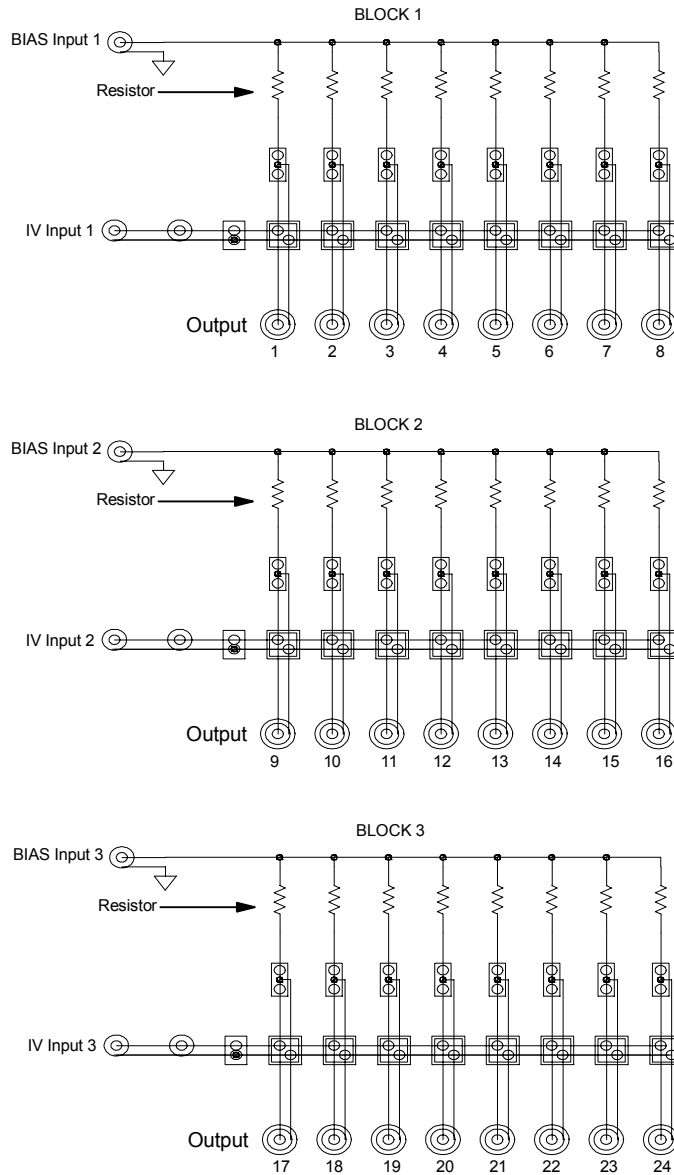
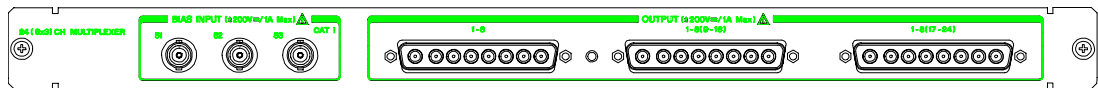

Table 1-2 E5255A Input/Output Connectors

2×8 multiplexer Block No.	BIAS INPUT (Port No.)	Output Port No.	OUTPUT Connector (Location)
Block1	BIAS1 (51)	Output 1 to 8	Left
Block2	BIAS2 (52)	Output 9 to 16	Center
Block3	BIAS3 (53)	Output 17 to 24	Right

Figure 1-6 E5255A BIAS INPUT Connectors and OUTPUT Connectors



WARNING

Do not touch the force and guard terminals of the OUTPUT connectors while the E5250A is turned on. Dangerous voltages up to the maximum input voltage may be present at the OUTPUT connectors.

CAUTION

The maximum voltage that can be applied to any input terminal is ± 200 Vdc. The maximum current is 1 Adc at ± 200 Vdc. The maximum voltage that can be applied between input terminals is 300 Vdc. Do not apply an input signal over these limits to the E5255A inputs. If you do, the E5255A will be damaged.

If you use a bias source that has current limit capability, set the bias source current limit to less than 1 Adc.

Options and Accessories

This section lists the options and accessories available for the E5250A.

Table 1-3 lists the options available for the E5250A.

Table 1-3

Options

Model Number	Option Item	Description
E5250A		Low Leakage Switch Mainframe
	E5250A-301	Relay Test Adapter
	E5250A-A6J	ANSI Z540 compliant calibration
	E5250A-UK6	Commercial cal. certificate w/ test data

Table 1-4 lists accessories furnished with the E5250A, E5252A, and E5255A.

Table 1-4 **Furnished Accessories**

Model Number	Part Number	Description	Qty.
E5250A	E5250-90000	Agilent E5250A User's Guide	1
	E5250-17001	E5250A VXI Plug&Play Driver Disk ^a	1
	E5250-17003	Agilent E5250A Program Disk. See next page. (LIF formatted, 3.5in diskette)	1
	04155-60007	Module Extractor	1
	8710-2151	Wrench (for removing plug-in card)	1
	–	Power Cable	1
E5252A	E5252-90000	Agilent E5252A Installation Guide	1
	8710-2151	Wrench (for removing plug-in card)	1
E5255A	E5255-90000	Agilent E5255A Installation Guide	1
	1250-0929	BNC Short Cap	3
	E5255-65000	BIAS Input Modification Kit (BNC Open Cap × 2, wire × 2)	1
	E5255-65001	0 Ω Resistor Set (10 resistors)	3
	E5255-65002	1.2 kΩ Resistor Set (10 resistors)	3
	E5255-65003	22 kΩ Resistor Set (10 resistors)	3
	8710-2151	Wrench (for removing plug-in card)	1

a. The Agilent E5250A VXI *plug&play* driver supports Windows XP Professional, Windows 2000, Windows NT 4.0, Windows 98, and Windows 95.

[Introduction](#)
[Options and Accessories](#)

Contents of the E5250A Program Disk:

Virtual Front

Panel Utility Interactive control program for the E5250A. Runs on Agilent 4155/4156's built-in IBASIC controller. Refer to Chapter 5.

VFP Data Upload

Library Subprogram library used for uploading the E5250A control data (made by Virtual Front Panel Utility) to your program. Runs on HP BASIC. Refer to Chapter 6.

**Capacitance
Compensation**

Routine Subprogram to compensate for capacitance error caused by the E5250A and E5252A. Runs on HP BASIC. This subprogram is used to compensate the capacitance data measured by Agilent 4284A Precision LCR Meter. Refer to Chapter 6.

Sample Programs Three sample programs: one for Vth and C measurement using the E5252A, and two for HCI test and analysis using the E5255A. Runs on HP BASIC. Refer to Chapter 9.

Self-test Utility Self-test and relay test program for the E5250A. Runs on the 4155/4156's built-in IBASIC controller. Refer to Chapter 3.

Table 1-5 lists accessories available for the E5250A.

Table 1-5 Available Accessories

Model Number	Option Item	Description
E5252A		10×12 Matrix Switch
E5255A		24 (8×3) Channel Multiplexer
16494A		Triaxial Cable
	16494A-001	1.5 m length
	16494A-002	3 m length
	16494A-003	80 cm length
16494B		Kelvin Triaxial Cable (4156 kelvin to E5250 kelvin)
	16494B-001	1.5 m length
	16494B-002	3 m length
	16494B-003	80 cm length
16494C		Kelvin Triaxial Cable (4142 kelvin to E5250 kelvin)
	16494C-001	1.5 m length
	16494C-002	3 m length
16494D		8 Channel Shielded Coaxial Cable
	16494D-001	1.5 m length
	16494D-002	3 m length
16494E		Wide Temperature 8 Channel Shielded Coaxial Cable
	16494E-001	3m length
16495C		Connector plate with 6 connectors for 16494D
16495D		Connector plate with 12 connectors for 16494D
16495E		Blank plate
16495F		Connector plate with 12×triaxial, intlk, GNDU
	16495F-001	Bulkhead feedthrough connectors (female to female)
	16495F-002	Connectors to contacts for soldering
16495G		Connector plate with 24×triaxial, intlk, GNDU
	16495G-001	Bulkhead feedthrough connectors (female to female)
	16495G-002	Connectors to contacts for soldering

Introduction
Options and Accessories

2 **Installation**

Installation

This chapter describes requirements to install Agilent E5250A and the tasks for installation, and is organized into the following three sections:

- “To Inspect the E5250A and Accessories” describes how to inspect the E5250A when you receive it.
- “Requirements” explains the information required for operating, storing, and shipping the E5250A.
- “Installing the E5250A” describes how to install the E5250A.
- “Maintenance” describes about performance verification and cleaning.



WARNING

The maximum input voltage of the E5250A is ± 200 V. And dangerous voltages may be present at the E5250A output terminals. To prevent electric shock, you must observe the following safety precautions when using the E5250A.

- **Use a three-conductor ac power cable to connect cabinet (if used) and the E5250A to an electric ground (safety ground).**
 - **If you need to touch the force and guard terminals of the output connector, turn off the E5250A and discharge any capacitors whenever possible.**
 - **Warn workers around the E5250A about dangerous conditions.**
-

To Inspect the E5250A and Accessories

When you receive and open the box that contains the E5250A, check the following:

- Before unpacking any components, inspect all boxes for any signs of damage that might have occurred during shipment such as:
 - Dents
 - Scratches
 - Cuts
 - Water marks
- When you open the boxes that contain the E5250A, check the components against the contents lists that are attached to the boxes.
- After installing the E5250A, check the E5250A operation by executing self-test shown in Chapter 3.

If anything is wrong, notify your local Agilent Technologies sales office.

When shipping the E5250A

When you unpack the E5250A, retain all packing materials for future use. If it becomes necessary to reship the E5250A, repack it in the original packing materials and shipping carton.

Requirements

This section describes the following requirements for the E5250A.

- “Power Requirements”
- “Power Cable”
- “Operating Environment”
- “Storage and Shipping Environment”

Power Requirements

CAUTION

Before applying ac line power to the E5250A, ensure that the correct power cable is used.

The E5250A can operate from any single-phase ac power source supplying 100 to 240 V \pm 10 % in the frequency range from 47 to 63 Hz. The maximum power consumption is 100 VA. For details, refer to Chapter 10, “Specifications.”



Power Cable

In accordance with international safety standards, this instrument is equipped with a three-wire power cable. When connected to an appropriate ac power outlet, this cable grounds the instrument frame. The type of power cable shipped with each instrument depends on the country of destination. Refer to the following table for the part numbers of the power cables available.

If the plug on the cable does not fit the power outlet, or the cable is to be attached to a terminal block, cut the cable at the plug end and re-wire it. This work should be performed by a qualified electrician all local electrical codes being strictly observed.

The color coding used in the cable will depend on the cable supplied. If a new plug is to be connected, it must meet local safety requirements and include the following features:

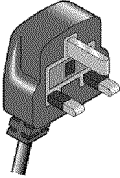
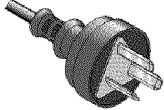
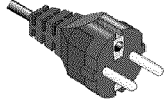
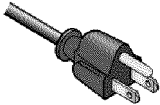
- Adequate load-carrying capacity. (refer to Chapter 10, “Specifications.”)
- Ground connection.
- Cable clamp.

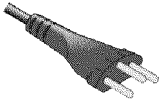
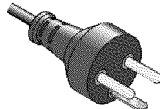
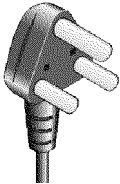
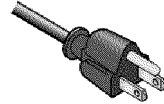
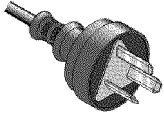
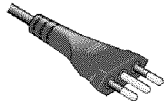
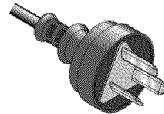
 <ul style="list-style-type: none"> • Plug: BS 1363/A, 250 V, 10 A • Cable: 8120-1351 	 <ul style="list-style-type: none"> • Plug: AS 3112, 250 V, 10 A • Cable: 8120-1369 	 <ul style="list-style-type: none"> • Plug: CEE 7 Standard Sheet VII, 250 V, 10 A • Cable: 8120-1689
 <ul style="list-style-type: none"> • Plug: NEMA 5-15P, 125 V, 10 A • Cable: 8120-1378 	 <ul style="list-style-type: none"> • Plug: NEMA 6-15P, 250 V, 6 A • Cable: 8120-0698 	 <ul style="list-style-type: none"> • Plug: SEV Type 12, 250 V, 10 A • Cable: 8120-2104
 <ul style="list-style-type: none"> • Plug: SR 107-2-D, 250 V, 10 A • Cable: 8120-2956 	 <ul style="list-style-type: none"> • Plug: IEC 83-B1, 250 V, 10 A • Cable: 8120-4211 	 <ul style="list-style-type: none"> • Plug: JIS C 8303, 125 V, 12 A • Cable: 8120-4753
 <ul style="list-style-type: none"> • Plug: Argentine Resolution 63, Annex IV, 250 V, 10 A • Cable: 8120-6870 	 <ul style="list-style-type: none"> • Plug: CEI 23-16, 250 V, 10 A • Cable: 8120-6978 	 <ul style="list-style-type: none"> • Plug: GB 1002, 250 V, 10 A • Cable: 8120-8376

WARNING

For protection from electrical shock, the power cable ground must not be defeated.

Operating Environment

The E5250A must be operated within the following environmental conditions:

- Temperature: 5 °C to 40 °C (41 °F to 104 °F)
- Humidity: 5 % to 80 % RH at 40 °C (104 °F), non-condensing
- Altitude: 0 m to 2000 m

Storage and Shipping Environment

The E5250A should be stored or shipped in environments within the following limits:

- Temperature: -40 °C to 70 °C (-40 °F to 158 °F).
- Humidity: 5 % to 90 % RH at 65 °C (149 °F).
- Altitude: 0 m to 15,240 m

Protect the E5250A from temperature extremes to prevent condensation from forming inside the E5250A.

Installing the E5250A

This section describes how to install the E5250A.

- “To Install Plug-in Card”
- “To Install Blank Panel”
- “To Configure E5255A”
- “E5255A Configuration Examples”
- “To Set GPIB Address”
- “To Connect GPIB Cable”



WARNING

To prevent electrical shock, turn off the mainframe and remove the power cable before starting the instruction.

CAUTION

Be careful about the module pins used for internal connection to the mainframe. The pins can be damaged easily.

Use clean handling and anti-static procedures when removing, configuring, and installing the modules. The modules contain components that can be damaged by static electricity.

NOTE

Plug-in module is shipped from the factory after the specifications are confirmed. Agilent can guarantee that the modules will function and that the module performance is designed to meet its specifications. However, if you have any trouble, contact your nearest Agilent Technologies service center.

If you require that the modules be guaranteed to their specifications (for ISO compliance, etc.), then you must perform a calibration on the instrument (modules and mainframe together). For calibration, contact your nearest Agilent Technologies service center.

To Install Plug-in Card

The E5252As and E5255As are plug-in cards (modules). You install these cards in card slots 1 to 4 of the E5250A. The following procedure explains the card installation and removal:

1. Turn off the E5250A, then wait at least 10 seconds before you remove or install a card.
2. Remove a blank panel or a card attached to the slot you want to install a new card, as follows.

To remove blank panel, do as follows:

- a. Loosen the screws on both the left and right edges of the blank panel by using the wrench furnished with the E5250A.
- b. Remove the blank panel.

To remove a card, do as follows:

- a. Screw the Module Extractor into the screw hole for the extractor. See Figure 2-1. Module Extractor is furnished with the E5250A.
 - b. Loosen the screws on left and right edges of the card by using the wrench furnished with the E5250A.
 - c. Gently pull the Module Extractor to extract the card from the card slot.
3. Install the card as follows:
 - a. Align the card with the left and right slot guide rails. The component side should be facing up.
 - b. Push the card into the slot until you feel it seat firmly into the connector at the back of the card slot.
 - c. Screw in the screws on the left and right edges of the card by using the wrench furnished with the E5250A.
 4. Execute the Relay Test and Leak Test:

After installing the cards, perform the Relay Test and Leak Test described in Chapter 3 to check the operation and leak current of the E5250A with installed cards.

CAUTION

If you want to confirm that the E5250A with installed cards meets its specifications, return the E5250A with installed cards to your nearest Agilent Technologies Service Center to do the Performance Verification.

Figure 2-1

Module Extractor and Location of the Screw Hole

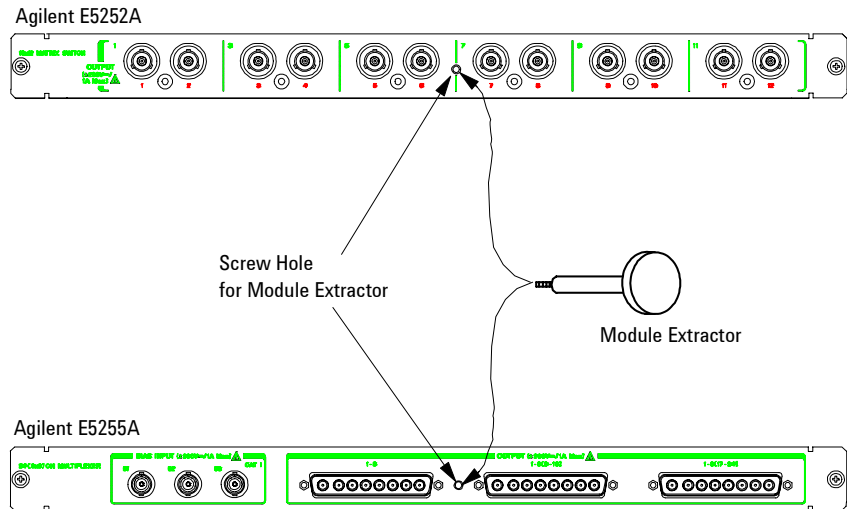

To Install Blank Panel

CAUTION

To prevent thermal damage to the E5250A cards, be sure that blank panels (Agilent part number E5250-60003) are installed in all unused slots.

If the blank panel is not installed to cover an unused slot, install the blank panel as follows:

1. Align the blank panel over the unused slot.
2. Screw in the screws on the left and right edges of the blank panel by using the wrench furnished with the E5250A.

To Configure E5255A

The Agilent E5255A has three 2-input 8-output multiplexers. You can configure several multiplexers by modifying some internal connections. Component locations on the E5255A are shown in Figure 2-2, and the relationship of the multiplexer blocks and the components is shown in Table 2-1. Table 2-2 shows the initial setting of the E5255A internal connections. The setting does not depend on the slot in which the module is installed.

Table 2-1 Multiplexer Blocks and Components

Multiplexer block	Resistor holder	BIASin	BIASout	IVin cable	IVout connector	DIP SW
Block 1	holder 1	–	BIASout1	IVin1	IVout1	DIP SW1
Block 2	holder 2	BIASin2	BIASout2	IVin2	IVout2	DIP SW2
Block 3	holder 3	BIASin3	–	IVin3	IVout3	DIP SW3

Table 2-2 Agilent E5255A Initial Setup

Block number	IVin cable connection	BIASin/BIASout	Protective resistor
1	SMU1	BIAS INPUT 51	0 Ω
2	SMU2	BIAS INPUT 52	0 Ω
3	SMU3	BIAS INPUT 53	0 Ω

To Modify IV Input

IV input connection is defined by the connection of IVin cable and the setting of DIP switch shown in Figure 2-2. For actual examples of modifications, see “E5255A Configuration Examples”.

Each DIP switch has four bit switches. Bits 1 to 3 are used to specify which SMU input connector is connected to the IV input. Bit 4 of DIP switch is used to specify whether the protective resistors are 0 Ω or not. The DIP switches must be set properly after you complete the internal connection. Make sure you set the DIP switches correctly. If not, dangerous voltages may be applied to unexpected output connectors.

Figure 2-2

Agilent E5255A Component Locations

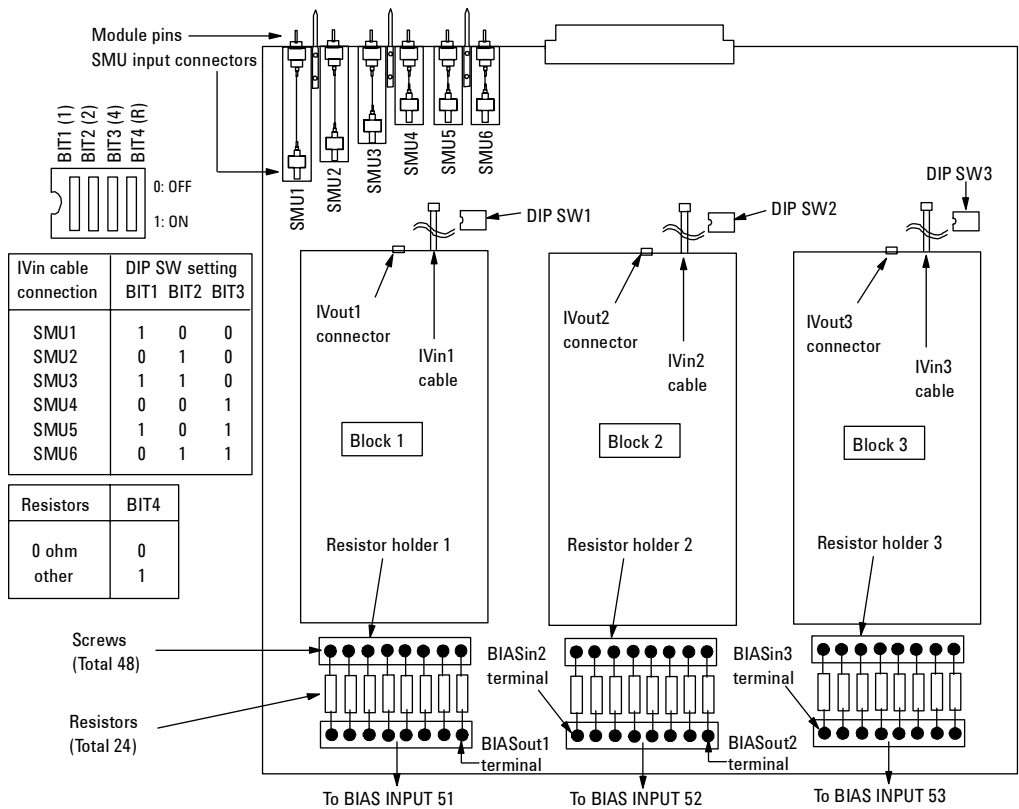

To Modify BIAS Input

⚠ Each multiplexer block has an independent BIAS input. You can change the BIAS input internally using the BIASin/BIASout terminals shown in Figure 2-2, or externally using the BIAS INPUT connectors. For actual examples of modifications, see “E5255A Configuration Examples”.

To Use Multiplexer Blocks on another E5255A

When a module is installed in a mainframe slot, six module pins are connected to the mainframe internal bus. So, if multiplexers on different E5255As use the same module pin, the IV inputs are connected together via the internal bus.

Installation

Installing the E5250A

For example, if a mainframe installs four E5255As which the IVin1 cable is connected to the SMU1 input connector and the IVin2 and IVin3 cables are not connected, the E5250A configures a 32-output multiplexer that uses the SMU INPUT 1 connector as the IV input.

To Mount Protective Resistors



To protect the device (DUT) from electrical damage, you can mount resistors between the IV input and BIAS input of multiplexer. The following procedure shows how to mount the resistors. See Figure 2-2 for the component locations.

When shipped from the factory, 0 Ω resistors are mounted, and bit 4 of all DIP switches is set to OFF (0).

1. Cut the original resistors (0 Ω) off.
2. Loosen the screws from both sides of the resistor holder.
3. Put resistors in holder, and tighten screws. And confirm that the resistors are held properly. Resistors should be mounted on each multiplexer block that you will use (8 resistors/block).
4. Set bit 4 to ON (1) for the DIP switch of the related block. For example, if you mount resistors for Block 1 and 2 multiplexers, set bit 4 to ON for DIP SW1 and SW2.

To Select Protective Resistors

Be careful about the following when selecting protective resistors. Also, be careful about the heating of the rear panel of mainframe or plug-in module, which may be heated by resistors, even if you follow this warning.

- If only one E5255A is installed in the mainframe:
Total power consumption by resistors must be less than 16W.
- If multiple E5255As are installed in the mainframe:
Total power consumption by resistors must be less than 32W.
- Consider the current flows to resistor when DUT shorts, and make sure the power consumption by resistor will be within specification of resistor. Do not use resistors that have specifications inadequate for your applications, which will result in resistors heating up, burning, or smoking.

E5255A Configuration Examples

The following example configurations are described:

- “24-output multiplexer (3-BIAS inputs, 1-IV input, 1 module)”
- “24-output multiplexer (1-BIAS input, 1-IV input, 1 module)”
- “96-output multiplexer (1-BIAS input, 1-IV input, 4 modules)”

24-output multiplexer (3-BIAS inputs, 1-IV input, 1 module)

To make this multiplexer, you need a E5255A. See Figure 2-3 for example setup. The example uses the SMU INPUT 1 connector as the IV input, and uses 0 Ω resistors.

Figure 2-3

24-output multiplexer (3-BIAS inputs, 1-IV input, 1 module)

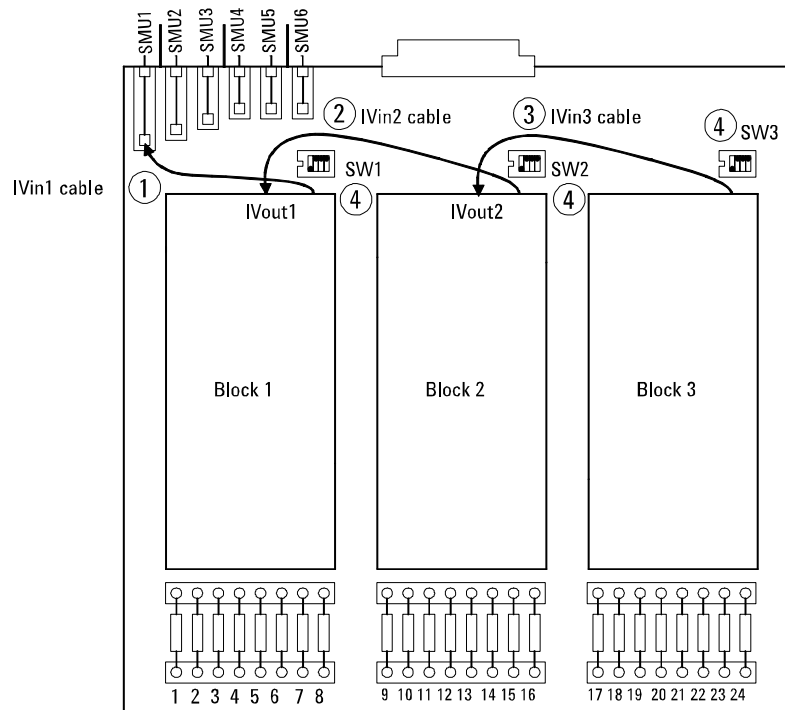

1. Connect the IVin1 cable to the SMU1 input connector on the E5255A.
2. Connect the IVin2 cable to the IVout1 connector.
3. Connect the IVin3 cable to the IVout2 connector.

Installation

Installing the E5250A

4. Set bit 1 to ON (1) and bit 2 thru 4 to OFF (0) for DIP SW1 to SW3.
5. Install the module into the slot 1 of the mainframe. For installing module, see “To Install Plug-in Card” on page 2-8.

24-output multiplexer (1-BIAS input, 1-IV input, 1 module)

To make this multiplexer, you need a E5255A, two wires (furnished), and two BNC open caps (furnished). See Figure 2-4 for example setup. The example uses the SMU INPUT 1 connector as the IV input, and uses 0 Ω resistors.

Figure 2-4

24-output multiplexer (1-BIAS input, 1-IV input, 1 module)

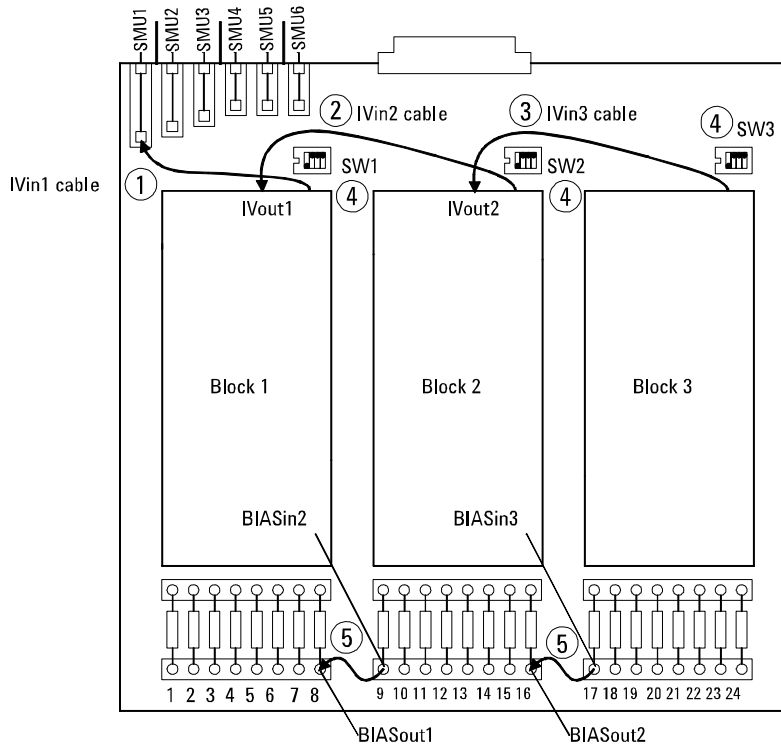

1. Connect the IVin1 cable to the SMU1 input connector on the E5255A.
2. Connect the IVin2 cable to the IVout1 connector.
3. Connect the IVin3 cable to the IVout2 connector.
4. Set bit 1 to ON (1) and bit 2 thru 4 to OFF (0) for DIP SW1 to SW3.

5. Connect wires between BIASout1 and BIASin2, also between BIASout2 and BIASin3.
6. Install the module into the slot 1 of the mainframe. For installing module, see “To Install Plug-in Card” on page 2-8.
7. Connect BNC open caps to BIAS INPUT 52 and 53 connectors. So, the BIAS INPUT 51 connector will be the BIAS input.

This example internally connects all BIAS INPUT connectors together. So, when bias is applied to a BIAS INPUT connector, the bias will also be applied to all the other BIAS INPUT connectors.

Do not forget to connect the BNC open caps to the unused BIAS INPUT connectors. Otherwise, you will be shocked if you touch the connectors while bias is applied. DO NOT connect the BNC short cap to the connectors. If you do, the E5255A and the Bias Source will be destroyed when the bias is applied.

To connect BIAS inputs externally.

You can use the BIAS INPUT connectors instead of the BIASin/out internal connections shown above. See Figure 2-5. This example uses three BNC cables and two BNC-T type (f-m-f) adapters. Recommended parts for the BNC-T type adapters are listed below.

- Agilent part number 1250-0781: female(side)-male(center)-female(side)
- Agilent part number 1250-2405: male(side)-female(center)-female(side)

Figure 2-5

Interconnection of BIAS INPUT Connectors

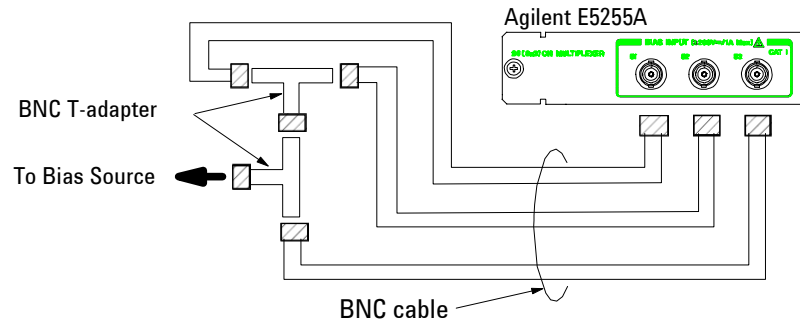

Installation
Installing the E5250A

96-output multiplexer (1-BIAS input, 1-IV input, 4 modules)

To make this multiplexer, you need four E5255As, eight wires (furnished), five BNC open caps (furnished), and three BNC cables. The example uses the SMU INPUT 1 connector as the IV input, and uses 0 Ω resistors.

1. See “24-output multiplexer (1-BIAS input, 1-IV input, 1 module)” and make four 24-output multiplexers. Then the IVin1 cable on all modules must be connected to the SMU1 input connector.
2. Install the modules into the mainframe. For installing module, see “To Install Plug-in Card” on page 2-8.
3. Connect BNC open caps to the BIAS INPUT 51 connector of the module in the slot 1 and all BIAS INPUT 52 connectors.
4. Connect BNC cables between the following connectors:
 - BIAS INPUT 51 (slot 4) and BIAS INPUT 53 (slot 3)
 - BIAS INPUT 51 (slot 3) and BIAS INPUT 53 (slot 2)
 - BIAS INPUT 51 (slot 2) and BIAS INPUT 53 (slot 1)

So, the BIAS INPUT 53 connector of the module in the slot 4 will be the BIAS input.

Figure 2-6

96-output multiplexer (1-BIAS input, 1-IV input, 4 modules)

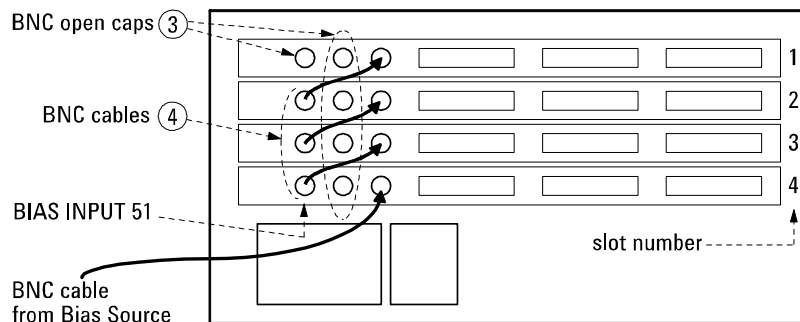

Do not forget to connect the BNC open caps to the unused BIAS INPUT connectors. Otherwise, you will be shocked if you touch the connectors while bias is applied. DO NOT connect the BNC short cap to the connectors. If you do, the E5255A and the Bias Source will be destroyed when the bias is applied.

To Set GPIB Address

Every device on the GPIB bus must have a unique address.

If you need to change the GPIB address of the E5250A, make sure the E5250A is turned off. With a small flatblade screwdriver, set the GPIB ADDRESS switch on the rear panel to the new address (0 to 30).

The new GPIB address is recognized only at power on. The E5250A leaves the factory with the GPIB address set to 22.

To Connect GPIB Cable

To connect the E5250A with a computer or peripheral device via GPIB (IEEE Std. 488), connect an GPIB cable between the GPIB connector on the E5250A rear panel and the GPIB connector on the peripheral device.

Including the controller, a total of 15 *GPIB interfaces* can be connected on the same GPIB bus. The following are rules for connecting GPIB interfaces:

- If total number of interfaces ≤ 10 :
Max. total cable length = number of interfaces \times 2 m.
- If total number of interfaces > 10 :
Max. total cable length = 20 m.
- Maximum cable length between interfaces is 4 m.
- Star connection and cascade connection are allowed. Loop connection is *not* allowed.

Maintenance

Maintenance should be performed periodically to keep the E5250A in good condition.

Performance Verification

Performance verification must be performed periodically so that the instruments satisfy the specifications, and keep a good condition. It is recommended to perform the performance verification once a year at least. For the performance verification, contact your nearest Agilent Technologies Service Center. Trained service personnel will perform the performance verification.

Cleaning

Before performing cleaning, turn off the instrument, and disconnect power cable from the rear panel. Use a dry cloth to clean the external case parts.

To prevent electrical shock, do not perform cleaning when the instrument is turned on, and do not use a wet cloth.

3 Executing Self-Test and Leak Test

Executing Self-Test and Leak Test

This chapter describes how to execute the Self-Test and the Leak Test.

The Self-Test consists of three tests that check the operation of Agilent E5250A firmware, LEDs, and key that are on the E5250A front panel, and the relays on the cards installed in the E5250A.

Self-Test should be executed every day as an operation check before using the E5250A.

The Leak Test checks leakage current of cards installed in the E5250A.

Leak Test can be executed by using Agilent 4155/4156 Semiconductor Parameter Analyzer with the Self-Test Utility program that is on the E5250A Program Disk furnished with the E5250A.

NOTE

Performance Verification

The Self-Test and the Leak Test *cannot* be used to verify the specifications of the E5250A, E5252A, and E5255A.

To verify the specifications, return the E5250A with the cards installed to your nearest Agilent Technologies Service Center. The performance verification should be done by service personnel who are trained to service the E5250A, and should be performed once a year.

-
- “Executing Self-Test” introduces the test items of the Self-Test and describes how to execute the Self-Test.
 - “Using the Self-Test Utility” describes how to execute the Self-Test and the Leak Test interactively from Agilent 4155/4156 semiconductor parameter analyzer.

Executing Self-Test

The Self-Test of the E5250A consists of the following three tests:

Table 3-1 E5250A Self-Test Items

Test Item	Description	Executed by	Refer to
Controller Test	Checks the operation of the E5250A firmware.	Turning on the E5250A.	page 3-4
		Entering SCPI Command.	page 3-6
		Using Self-Test Utility.	page 3-10
Front Panel Interface Test	Checks the operation of the LEDs and key that are on the E5250A front panel.	Entering SCPI Command	page 3-6
		Using Self-Test Utility.	page 3-10
Relay Test	Checks the operation of the relays on the cards installed in the E5250A.	Pressing the Local/ Self Test key.	page 3-4
		Entering SCPI Command.	page 3-6
		Using Self-Test Utility.	page 3-10

To Execute Self-Test (Standalone)

Controller Test is executed automatically when you turn on the E5250A. You execute the Relay Test by pressing the **Local/Self Test** key on the E5250A front panel.

Executing the Controller Test

1. Turn on the E5250A.
2. Wait until the LED in the **Local/Self Test** key turns off.

If System Fail LED or Fail LED stays on after executing the Controller Test, contact your nearest Agilent Technologies Service Center.

Executing the Relay Test

Requirements:

- Relay Test Adapter (E5250A-301)
- BNC Short Caps (3 caps are furnished with each E5255A)

Procedure:

1. Disconnect all cables from the E5250A input connectors.
2. Open all outputs of the plug-in cards as follows: If cable is connected to output connector of plug-in card, open output at DUT end of cable. If end of cable is Kelvin connection, disconnect the cable or make non-Kelvin connection at end of cable.
3. Attach the Relay Test Adapter to the E5250A input connectors as shown in Figure 3-1.
4. Set switch on the Relay Test Adapter to **Relay Test** position.
5. For each E5255A card installed in the E5250A:
 - a. Disconnect any cables from the BIAS INPUT connectors of the E5255A.
 - b. Connect a BNC Short Cap to each E5255A BIAS INPUT connector.
6. (If Remote LED is on, press the **Local/Self Test** key to return to Local control. The Remote LED should turn off.)
7. Press the **Local/Self Test** key. The Relay Test executes.
8. Wait until the LED in **Local/Self Test** key turns off.

NOTE

If Fail LED is ON after Relay Test

After executing the relay test, if the Fail LED turns on, the cause is one of the following:

- The Relay Test Adapter is not connected or a cable is still connected to input connector.
- Output is not open. See step 2 of previous procedure.
- You did not properly install the E5255A. See “To Configure E5255A” on page 2-10.
- A plug-in card may be defective. Contact your nearest Agilent Technologies Service Center.

Figure 3-1

Relay Test Adapter Connection

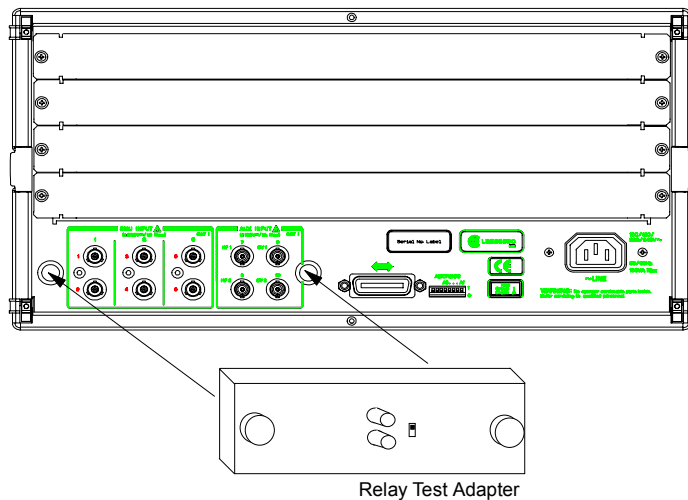

NOTE

Settings after Relay Test

After Relay Test, the E5250A settings are changed to same as after :SYST:CPON command execution.

To Execute Self-Test using External Controller

You can execute Self-Test from an external controller by using SCPI commands in a program.

This section describes the requirements, SCPI commands, and a sample program for Self-Test execution from an external controller. For details about the SCPI commands, refer to Chapter 7.

Requirements

- Controller
- GPIB Cable
- Relay Test Adapter
- BNC Short Caps (3 caps are furnished with each E5255A)

SCPI Commands for Self-Test

Table 3-2 shows the SCPI commands used to execute Self-Test. Keyword of the SCPI command first level is :DIAG.

The :DIAG commands ignore the E5250A channel configuration mode (NORMAL or AUTO).

For :DIAG commands that require a card number, you specify 1, 2, 3, 4, or ALL.

If the Fail LED turns on after executing the Self-Test, the E5250A or modules may be defective. Contact your nearest Agilent Technologies Service Center.

NOTE

Before executing Relay Test, be careful about following:

- Attach the Relay Test Adapter to the E5250A input connectors. Refer to Figure 3-1. Then set the switch on the adapter to the *Relay Test* position.
 - Open all outputs of the plug-in cards as follows: If cable is connected to output connector of plug-in card, open output at DUT end of cable. If end of cable is Kelvin connection, disconnect the cable or make non-Kelvin connection at end of cable.
 - For each E5255A installed in the E5250A, connect a BNC short cap to each E5255A BIAS INPUT connector.
-

Table 3-2 SCPI Commands for Self-Test

Test Item	Description	SCPI Command
Controller Test	Executes Controller Test, then returns test result.	:DIAG:TEST:FRAM:EXEC? CONT
	Returns test result.	:DIAG:TEST:FRAM:STAT? CONT
	Clears test result.	:DIAG:TEST:FRAM:CLE CONT
Front Panel Interface (I/F) Test	Executes I/F Test, then returns test result.	:DIAG:TEST:FRAM:EXEC? FPAN
	Returns test result.	:DIAG:TEST:FRAM:STAT? FPAN
	Clears test result.	:DIAG:TEST:FRAM:CLE FPAN
Relay Test	Executes Relay Test, then returns test result.	:DIAG:TEST:CARD:EXEC? ALL or <i>Card No.</i> (1, 2, 3, or 4)
	Returns test result.	:DIAG:TEST:CARD:STAT? ALL or <i>Card No.</i> (1, 2, 3, or 4)
	Clears test result.	:DIAG:TEST:CARD:CLE ALL or <i>Card No.</i> (1, 2, 3, or 4)

NOTE

Front Panel Interface Test

After the :DIAG:TEST:FRAM:EXEC? FPAN command is executed, the Remote, System Fail, Fail, and Local/Self Test LEDs on the E5250A front panel blink for about 10 seconds. If an LED does not blink, the LED is defective.

Confirm that the four LEDs are blinking, then press the **Local/Self Test** key on the E5250A front panel within 10 seconds. The LEDs should stop blinking.

If you do not press the **Local/Self Test** key within 10 seconds, the E5250A returns a fail result for the Front Panel Interface Test, which turns on the Fail LED.

If you pressed **Local/Self Test** key within 10 seconds, and the Fail LED still turns on, it means the **Local/Self Test** key is defective.

If you find any problem, contact your nearest Agilent Technologies Service Center.

Executing Self-Test and Leak Test

Executing Self-Test

Self-Test Programming Example

This sample program is effective for an E5250A that has four cards installed. If your E5250A does not have four cards installed, delete the Relay Test program lines for the empty card slots. The program runs on HP BASIC.

```
10 ! Self-Test by External Controller
20 !
30 REAL A
40 ASSIGN @Hp5250 TO 722
50 OUTPUT @Hp5250;":DIAG:TEST:FRAM:CLE CONT"
60 OUTPUT @Hp5250;":DIAG:TEST:FRAM:CLE FPAN"
70 OUTPUT @Hp5250;":DIAG:TEST:CARD:CLE ALL"
80 DISP "Press Continue to go to Controller Test."
90 PAUSE
100 ! Controller Test
110 OUTPUT @Hp5250;":DIAG:TEST:FRAM:EXEC? CONT"
120 ENTER @Hp5250;A
130 IF A=0 THEN GOTO 160
140 DISP "Failed. Press Continue to go to I/F Test."
150 GOTO 170
160 DISP "Passed. Press Continue to go to I/F Test."
170 PAUSE
180 ! Front Panel I/F Test
190 OUTPUT @Hp5250;":DIAG:TEST:FRAM:EXEC? FPAN"
200 DISP "Press Local/Self Test Key within 10 sec."
210 ENTER @Hp5250;A
220 IF A=0 THEN GOTO 250
230 DISP "Failed. Press Continue to go to Relay Test."
240 GOTO 260
250 DISP "Passed. Press Continue to go to Relay Test."
260 PAUSE
270 ! Relay Test
280 OUTPUT @Hp5250;":DIAG:TEST:CARD:EXEC? 1"
290 ENTER @Hp5250;A
300 IF A=0 THEN GOTO 330
310 DISP "Card 1 failed. Press Continue to test Card 2"
320 GOTO 340
330 DISP "Card 1 passed. Press Continue to test Card 2"
340 PAUSE
350 OUTPUT @Hp5250;":DIAG:TEST:CARD:EXEC? 2"
360 ENTER @Hp5250;A
370 IF A=0 THEN GOTO 400
380 DISP "Card 2 failed. Press Continue to test Card 3"
390 GOTO 410
400 DISP "Card 2 passed. Press Continue to test Card 3"
410 PAUSE
420 OUTPUT @Hp5250;":DIAG:TEST:CARD:EXEC? 3"
```

```

430  ENTER @Hp5250;A
440  IF A=0 THEN GOTO 470
450  DISP "Card 3 failed. Press Continue to test Card 4"
460  GOTO 480
470  DISP "Card 3 passed. Press Continue to test Card 4"
480  PAUSE
490  OUTPUT @Hp5250;":DIAG:TEST:CARD:EXEC? 4"
500  ENTER @Hp5250;A
510  IF A=0 THEN GOTO 540
520  DISP "Card 4 failed."
530  GOTO 550
540  DISP "Card 4 passed."
550  END

```

Line Number	Description
30 to 90	Clears all previous test results.
100 to 170	Executes the Controller Test, then returns test result.
180 to 260	Executes the Front Panel Interface Test, then returns the test result.
270 to 340	Executes the Relay Test for the card installed in slot 1 of the E5250A, then returns test result.
350 to 410	Executes the Relay Test for the card installed in slot 2 of the E5250A, then returns test result.
420 to 480	Executes the Relay Test for the card installed in slot 3 of the E5250A, then returns test result.
490 to 550	Executes the Relay Test for the card installed in slot 4 of the E5250A, then returns test result.

Using the Self-Test Utility

The Self-Test Utility is a Self-Test program for the E5250A, and runs on the Agilent 4155/4156's built-in IBASIC controller.

Self-Test Utility can execute all Self-Test items listed in Table 3-1 and can also execute the Leak Test, which checks leakage current of the E5250A with installed cards. You execute the Self-Test items and Leak Test interactively (using softkeys) from the 4155/4156.

This section explains the operation of the Self-Test Utility.

- “Requirements”
- “To Start the Self-Test Utility”
- “To Execute Self-Test”
- “To Execute Leak Test”

Requirements

The following equipment is required to execute the Self-Test Utility:

Table 3-3

Required Equipment

Agilent Model/Part No.	Description	Qty.	Usage
4155 or 4156	Semiconductor Parameter Analyzer	1	Executing Self-Test Utility
10833A/B/C	GPIB Cable	1	
E5250-17003	E5250A Program Disk (furnished)	1	
E5250A-301 (E5250-60002)	Relay Test Adapter	1	Relay Test
1250-0929	BNC Short Cap	3 for each E5255A (furnished with the E5255A)	

To Start the Self-Test Utility

1. Before turning on the 4155/4156 and E5250A, connect the GPIB cable between the E5250A and the 4155/4156.
2. Turn on the 4155/4156 and E5250A.
3. Set the 4155/4156 to "SYSTEM CONTROLLER" mode on SYSTEM: MISCELLANEOUS page.
4. Insert the E5250A Program Disk into the 4155/4156 disk drive.
5. Press the **Display** key twice to display the "All IBASIC" screen. This key is located in the IBASIC area on the 4155/4156 front panel.
6. Select GET softkey on the 4155/4156 screen. The following is displayed:

```
GET " _ "
```

7. Type SELFTEST between the double quotations of GET statement. Then press **Enter** key. Wait until the 4155/4156 finishes getting the file.
8. Press **Run** key, which is in the IBASIC area on the 4155/4156 front panel. The following message is displayed:

```
Input Agilent E5250A GPIB Address (default 722):?
```

9. To use default GPIB address 722, just press the **Enter** key. If not, type the GPIB address of your E5250A, then press **Enter** key. MAIN MENU of the E5250A Self-Test Utility and following softkeys are displayed on the 4155/4156:

Softkey	Description
SELF TEST	Displays the SELF TEST MENU.
LEAK TEST	Displays the LEAK TEST MENU.
QUIT	Quits the Self-Test Utility.

To Execute Self-Test

On the MAIN MENU of the E5250A Self-Test Utility, select the SELF TEST softkey to display the E5250A SELF TEST MENU and following softkeys:

Softkey	Description
CARD1 RELAY	For executing Relay Test for Card1.
CARD2 RELAY	For executing Relay Test for Card2.
CARD3 RELAY	For executing Relay Test for Card3.
CARD4 RELAY	For executing Relay Test for Card4.
CONTROLLER	Executes Controller Test immediately.
FRONT PANEL	Executes Front Panel I/F Test immediately.
MAIN MENU	Returns to MAIN MENU of Self-Test Utility immediately.

Also, the most recent Self-Test result (P/F/N) is displayed on the 4155/4156 screen.

Figure 3-2

Example of SELF TEST MENU

```
Agilent E5250A Test Utility
** SELF TEST MENU **

CARD1 RELAY ... Start Slot1 E5255A Relay Test      [N]
CARD2 RELAY ... Start Slot2 E5255A Relay Test      [N]
CARD3 RELAY ... Start Slot3 E5255A Relay Test      [N]
CARD4 RELAY ... Start Slot4 E5255A Relay Test      [N]
CONTROLLER ... Start E5250A Controller Test       [P]
FRONT PANEL ... Start E5250A Front Panel UIF Test [N]
MAIN MENU ... Return to MAIN MENU
```

```
[P] indicates test was passed.
[F] indicates test was failed.
[N] indicates test was not executed.
```

```
Prepare the relay test adapters
before you select "CARDn RELAY" key.
```

```
Select desired softkey.
```

```
-
```

Executing the Controller Test

To execute the controller test, press the CONTROLLER softkey.

If [F] result is displayed after the test, the E5250A is defective. Contact your nearest Agilent Technologies Service Center.

Executing the Front Panel Interface Test

To execute the front panel interface test, do the following:

1. Press the FRONT PANEL softkey.
2. Confirm that the following four LEDs on the E5250A front panel are blinking. And press the **Local/Self Test** key on the E5250A front panel within 10 seconds.
 - Remote LED
 - System Fail LED
 - Fail LED
 - Local/Self Test LED

NOTE

Fail Condition for Front Panel Interface Test

If an LED does not blink after selecting the FRONT PANEL softkey, the LED is defective.

If you do not press the **Local/Self Test** key within 10 seconds, the Fail LED turns on.

If you pressed **Local/Self Test** key within 10 seconds, and the Fail LED still turns on, it means the **Local/Self Test** key is defective.

Contact your nearest Agilent Technologies Service Center.

Executing the Relay Test

To execute the Relay Test, do the following:

1. Press the CARDn RELAY softkey ($n=1$ to 4). The following message is displayed on the 4155/4156 screen depending on card:

- Message for the E5252A:

Attach the relay test adapter on input terminal and
open all output of slot n.

- Message for the E5255A:

Attach the relay test adapter and the BNC short cap to
E5250A/E5255A input. And open all output of slot n.

Where, $n=1$ to 4.

And the following softkeys are displayed.

Softkey	Description
CONTINUE	Executes the Relay Test for the card immediately.
CANCEL	Cancels the Relay Test execution.

2. Disconnect all cables from the E5250A input terminals. And attach the Relay Test Adapter to the E5250A input terminals. For each E5255A card, connect a BNC short cap to each E5255A BIAS INPUT port.
3. Open all outputs of the plug-in cards as follows:
If cable is connected to output connector of plug-in card, open output at DUT end of cable. If end of cable is Kelvin connection, disconnect the cable or make non-Kelvin connection at end of cable.
4. Press the CONTINUE softkey to execute the Relay Test.
Or press the CANCEL softkey to cancel test execution.
5. Repeat steps 1 to 4 for the each card you want to test.

If [F] result is displayed after executing the Relay Test, the card is defective. Contact your nearest Agilent Technologies Service Center.

To Execute Leak Test

NOTE

Leak Test is for checking leakage current of the E5250A with plug-in cards installed. If leak test result is too large for your application, contact nearest Agilent Technologies Service Center. Leak test does not verify specifications of the E5250A and installed cards.

The Leak Test applies 10 Vdc to the specified input port of the E5250A, and measures the leakage current. The test limits are shown in Table 3-4.

You specify an input port of the E5250A, and specify the 4155/4156 SMU to use. The Leak Test automatically connects the specified input port to each output port consecutively, and uses the 4155/4156 SMU to measure the leakage current for each channel.

You need to execute this test for each input port.

Table 3-4

Test Limits of Leak Test

Card	Instrument	Connection	Input Port	Test Limit
E5252A	4155	non-Kelvin	IV1, IV2	±4.12 pA
			IV3, IV4, IV5, IV6	±1.01 nA
	4156	non-Kelvin	IV1, IV2	±1.14 pA
			IV3, IV4, IV5, IV6	±1.01 nA
		Kelvin	IV1, IV2	±2.24 pA
			IV3, IV4, IV5, IV6	±2.02 nA
E5255A	4155	non-Kelvin	IV1 to IV6	±4.12 pA
	4156	non-Kelvin	IV1 to IV6	±1.14 pA

Executing Self-Test and Leak Test Using the Self-Test Utility

To execute the Leak Test, do the following:

1. On MAIN MENU of the E5250A Self-Test Utility, select LEAK TEST softkey. The following message is displayed:

```
Input Agilent 4155/4156 GPIB address (default 817):?
```

2. To use default GPIB address 817 for the 4155/4156, just press **Enter** key. If not, type GPIB address of the 4155/4156, then press **Enter** key.

The LEAK TEST MENU with the following softkeys are displayed:

Softkey	Description
START TEST	For defining the Leak Test connection. Need to define the E5250A input port and 4155/4156 SMU port.
MAIN MENU	Returns to MAIN MENU of the Self-Test Utility.

3. Select START TEST softkey. Following message/softkeys are displayed:

```
Select IV Port of Leak Test by softkey.
```

Softkey	Description
IV n ($n=1$ to 6)	For specifying the E5250A SMU INPUT n port for which you want to perform the leak measurement. If only the E5255As are installed, only IV n softkeys displayed are for SMU INPUT n internally connected to the E5255A IV input.
CANCEL	Cancels the Leak Test execution.

4. Select desired IVn softkey ($n=1$ to 6) for input port you want to test.

If the E5252A is installed in your E5250A, and the 4156 is used for the Relay Test, then when you press IV1, IV3, or IV5 softkey, the following message and softkeys are displayed:

Is IVn Port a Kelvin connection?

Where $n=1, 3, \text{ or } 5$.

Softkey	Description
YES	Declares that the port specified by the IVn softkey is used for the Kelvin connection.
NO	Declares that the port specified by the IVn softkey is used for the non-Kelvin connection.
CANCEL	Cancels the Leak Test execution.

Select the YES or NO softkey.

The following message and the softkeys are displayed:

Select SMU channel for IVn leak measurement by softkey.

Where $n=1$ to 6.

Softkey	Description
SMUm ($m= 1$ to 6)	Declares that you will connect the 4155/4156 SMUm to the E5250A port specified by the IVn softkey. SMU5 and SMU6 are displayed only if 5th and 6th SMU are installed in the 41501 expander of the 4155/4156.
CANCEL	Cancels the Leak Test execution.

Executing Self-Test and Leak Test Using the Self-Test Utility

5. Select the desired SMU m softkey ($m=1$ to 6). Following message is displayed depending on the connection type:

- Message for Kelvin connection:

```
Disconnect Kelvin cable from IVn terminal.  
And disconnect all cables from output terminals.
```

- Message for non-Kelvin connection:

```
Disconnect cable from IVn terminal.  
And disconnect all cables from output terminals.
```

Where $n=1$ to 6. And the following softkeys are displayed.

Softkey	Description
CONTINUE	To continue setting up the Leak Test.
CANCEL	Cancels the Leak Test execution.

6. Disconnect all cables from the E5250A input/output terminals. Then connect triaxial cable or Kelvin triaxial cable to the 4155/4156 SMU terminal you specified in step 5 because the next step executes the zero offset cancel.
7. Select the CONTINUE softkey. The following message is displayed depending on the connection type:

- Message for Kelvin connection:

```
Connect SMU $m$  to IVn by Kelvin cable.
```

- Message for non-Kelvin connection:

```
Connect SMU $m$  to IVn by cable.
```

Where $m=1$ to 6 (specified by SMU m softkey) and $n=1$ to 6 (specified by IV n softkey).

And the following softkeys are displayed.

Softkey	Description
CONTINUE	Executes the Leak Test. Consecutively connects input port specified by IV n softkey to each output port and makes leak measurement.
CANCEL	Cancels the Leak Test execution.

8. Connect the cable from the 4155/4156 SMU port specified by the SMUm softkey ($m=1$ to 6) in step 5 to the E5250A input port specified by the IVn softkey ($n=1$ to 6) in step 4.
 - Use Kelvin triaxial cable for Kelvin connection
 - Use triaxial cable for non-Kelvin connection
9. Press the CONTINUE softkey to execute the Leak Test.

After the Leak Test is completed for the input port specified by the IVn softkey, the test result (PASS or FAIL) is displayed on the 4155/4156 screen. And the following softkeys are displayed:

Softkey	Description
REPORT CRT	Displays the Leak Test results on the 4155/4156 screen.
LEAK TEST	Returns to the LEAK TEST MENU.

To display the leak current measurement data on the 4155/4156 screen, press the REPORT CRT softkey.

10. To return to the LEAK TEST MENU, select the LEAK TEST softkey. And to perform the Leak Test for another input port, repeat steps 3 to 9.

Executing Self-Test and Leak Test
Using the Self-Test Utility

4**Setting up Measurement Environment**

Setting up Measurement Environment

This chapter explains how to connect your instruments to Agilent E5250A input, and how to connect the E5250A output to your wafer prober or test fixture.

You can connect the E5250A output (E5252A or E5255A) to your prober or fixture in the following three ways:

- Via the available connector plates.
- (For E5255A only) Directly using Agilent 16494E coaxial cable.
- Via connectors that you mount directly on your own connector plate or test fixture.

This chapter explains how to do this in the following sections:

- “Connector Plates” introduces connector plates available for the plug-in card. For installing the connector plates on your shielding box for prober or fixture, refer to Agilent 16495 *Installation Guide*.
- “Connecting 8-Channel Shielded Coaxial Cable” explains how to use the 16494E coaxial cable, which is used to directly connect the E5255A output to the DUT, DUT socket, or any fixture you want without using a connector plate.
- “Mounting Connectors Directly” describes connector hole dimensions for mounting connectors directly on your own connector plate or test fixture, and describes the information to connecting the connectors to prober, socket or DUT.
- “Connecting the E5250A Input” explains how to connect instruments to the E5250A input.
- “Connecting the E5250A Output” describes the information to connect the plug-in card output to a connector plate, connectors on your own shielding box and so on.
- “Measurement Cable Length” is a reference for deciding total cable length at your site by calculating the total guard capacitance according to the cable length from instrument to Device Under Test (DUT).

Connector Plates

A connector plate is the interface to connect the E5250A to your prober or test fixture. The following connector plates are available for the E5250A. To install the connector plate, refer to Agilent 16495 *Installation Guide*.

Connector Plates for the E5252A

16495F Half size connector plate for E5252A

16495F-001 has 12 triaxial through connectors (female to female), an Intlk connector, and a GNDU connector (triaxial through, female to female). The back of the Intlk connector is designed for soldering.

16495F-002 has 12 triaxial connectors, an Intlk connector, and a GNDU connector. The back of each connector is designed for soldering.

16495G Full size connector plate for E5252A

16495G-001 has 24 triaxial through connectors (female to female), an Intlk connector, and a GNDU connector (triaxial through, female to female). The back of the Intlk connector is designed for soldering.

16495G-002 has 24 triaxial connectors, an Intlk connector, and a GNDU connector. The back of each connector is designed for soldering.

Connector Plates for E5255A

16495C Half size connector plate for E5255A

The 16495C has six 8-channel shielded coaxial connectors, an Intlk connector, and a GNDU connector. The back of each connector is designed for soldering.

16495D Full size connector plate for E5255A

The 16495D has twelve 8-channel shielded coaxial connectors, an Intlk connector, and a GNDU connector. The back of each connector is designed for soldering.

Blank Plate

16495E

Half size blank plate.

This plate is used to cover openings when you made too big openings for mounting the connector plate. You will use this plate to cover openings if you mount the half size connector plate in openings made for the full size connector plate.

Connecting 8-Channel Shielded Coaxial Cable

This section introduces Agilent 16494E wide temperature 8-channel shielded coaxial cable, and explains how to connect the 16494E to the Device Under Test (DUT).



WARNING

Do not connect the 16494E cable to the E5255A or any instrument until connecting to the DUT as described below. If you ignore this warning, you maybe exposed to dangerous voltage.

The 16494E coaxial cable is used to connect the E5255A output directly to the DUT, DUT socket, or any fixture you want without using the connector plate. One 16494E is used for one 8-channel output connector of the E5255A. To use 24 output channels (three 8-channel output connectors), you need three 16494Es.

Instrument Side

The instrument side of the 16494E cable can be connected directly to the E5255A output.

DUT Side

Solder the open side of the 16494E directly to DUT, DUT socket, or your test fixture as shown in Figure 4-1.

Figure 4-1

Example of DUT Connection

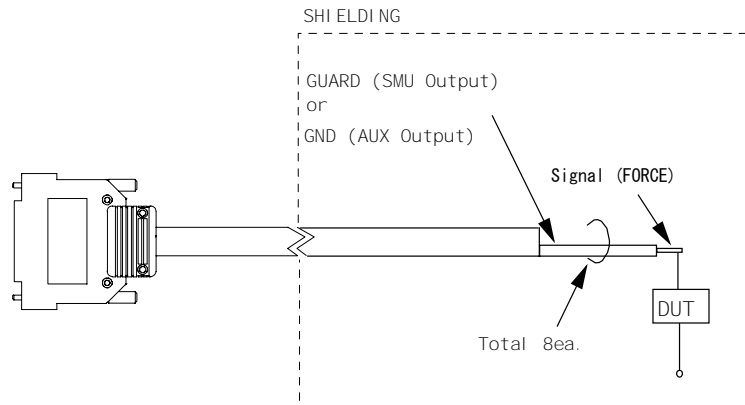

NOTE

For highly accurate current forcing and measurements with minimized leakage, extend the guard to surround the signal lines as close as possible to the DUT.

Mounting Connectors Directly

Previous sections described the information to use the available accessories, also the 16495 *Installation Guide* provides the information how to install connector plates on the shielding box. However, you may need to directly mount connectors on your own connector plate or test fixture.

In this case, you need to make connector holes and directly mount the connectors yourself. This section has dimension information about the holes you need to make. Do the following:

1. Select the appropriate parts for your situation. Refer to Table 4-1.
2. Make holes and mount the connectors. Refer to Table 4-2.

For kelvin connection, use the 16494B Kelvin cable. Kelvin cable requires the kelvin triaxial connector which has two connector holes and three screw holes.

3. Make interlock circuit as shown in “To Make Interlock Circuit” on page 4-8.
4. Make cable connection between connector and DUT (device under test). Refer to “To Connect Connectors to DUT” on page 4-13.

Table 4-1 lists the parts required to mount connectors on your shielding box. From this table, select the parts that you need to mount. Quantity of parts depends on your site.

Table 4-1 Recommended Parts

Usage	Agilent Part No.	Description
Making interlock circuit	1252-1419C	Interlock Connector (6 pin, female)
	3101-0302 or 3101-3241	Switch
	1450-0641	LED ($V_F \cong 2.1 \text{ V @ } I_F = 10 \text{ mA}$)
	8150-5680	Wire
Connecting E5252A output	1250-2457	Triaxial Connector (female)
	8121-1191	Low Noise Coaxial Cable
Connecting E5255A output	1251-2367	Connector Frame (female)
	1251-0179	Coaxial Connector (female) (8ea. required for one frame.)
	0380-3070	Screw (2ea. required for one frame.)
	2260-0002	Nut (2ea. required for one frame.)
	2190-0913	Washer (2ea. required for one frame.)
	8121-1191	Low Noise Coaxial Cable

Table 4-2 Dimensions of Connector Holes

Kelvin Triaxial Connector (in mm)	Triaxial Connector (in mm)
<p>Technical drawing of a Kelvin Triaxial Connector. It shows a top view with four circular holes. The horizontal spacing between the centers of the holes is 14 mm between the first and second, 11 mm between the second and third, 11 mm between the third and fourth, and 14 mm between the first and fourth. The vertical spacing between the top and bottom rows of holes is 10.3 mm. The diameter of each hole is 11.3 mm. There are two screws, each with a diameter of 3.2 mm and a length of 0.5 mm, positioned between the holes. The distance from the top edge of the connector to the center of the top row of holes is 2.8 mm.</p>	<p>Technical drawing of a Triaxial Connector. It shows a top view of a circular hole with a diameter of 11.3 mm. The distance from the top edge of the connector to the center of the hole is 10.3 mm.</p>
8 Channel Shielded Coaxial Connector (in mm)	Interlock Connector (in mm)
<p>Technical drawing of an 8 Channel Shielded Coaxial Connector. It shows a side view of a cylindrical component. The total length is 63.5 mm, and the length of the main body is 59 mm. The diameter of the main body is 6 mm. The distance from the end of the main body to the center of the connector is 12 mm. There are two holes, each with a diameter of 3 mm. The connector has a 10-degree chamfered edge and a radius of 1.5 mm. The drawing is labeled with 2 - Ø3, 4 - R1.5, and 10°.</p>	<p>Technical drawing of an Interlock Connector. It shows a side view of a circular hole with a diameter of 8.2 mm. The distance from the top edge of the connector to the center of the hole is 5.1 mm. The distance from the center of the hole to the top edge of the connector is 1.8 mm.</p>

To Make Interlock Circuit

The interlock circuit is to prevent electric shock when touching measurement terminals.

You must install an interlock circuit on shielding box to prevent dangerous voltages when door of the shielding box is open.

Figure 4-2 shows the pin assignments of the interlock connector mounted on your own connector plate or test fixture.

Figure 4-2

Interlock Connector Pin Assignments

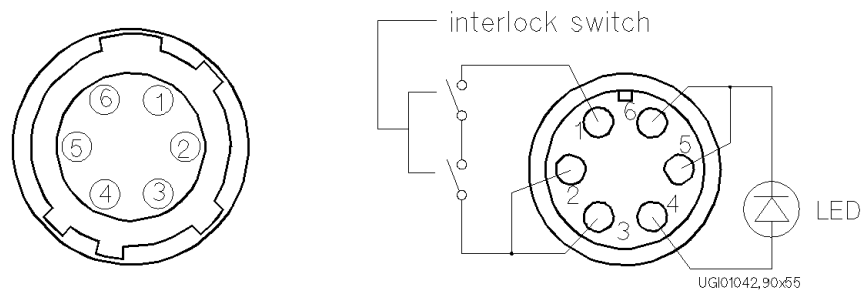

WARNING

Dangerous voltages of up to the maximum voltage of SMUs may be present at force, guard, and sense terminals when the interlock terminals are shorted.

To Install Interlock Circuit

Install the interlock circuit as follows.

1. Mount two mechanical switches on your shielding box, so that the switches close when the door of the shielding box is closed, and open when the door is opened. For the dimensions of the switch, refer to Figure 4-3 and Figure 4-4.
2. Use wire to connect the two switches in series between pin number 1 and 2 (or 3) of the interlock connector. See Figure 4-2.

For example, Agilent 4155/4156 is connected to the interlock circuit, it cannot force more than ± 40 V when the door is open. When door is closed, it can force more than ± 40 V.

Figure 4-3

Dimensions of Interlock Switch (Agilent part number 3101-0302)

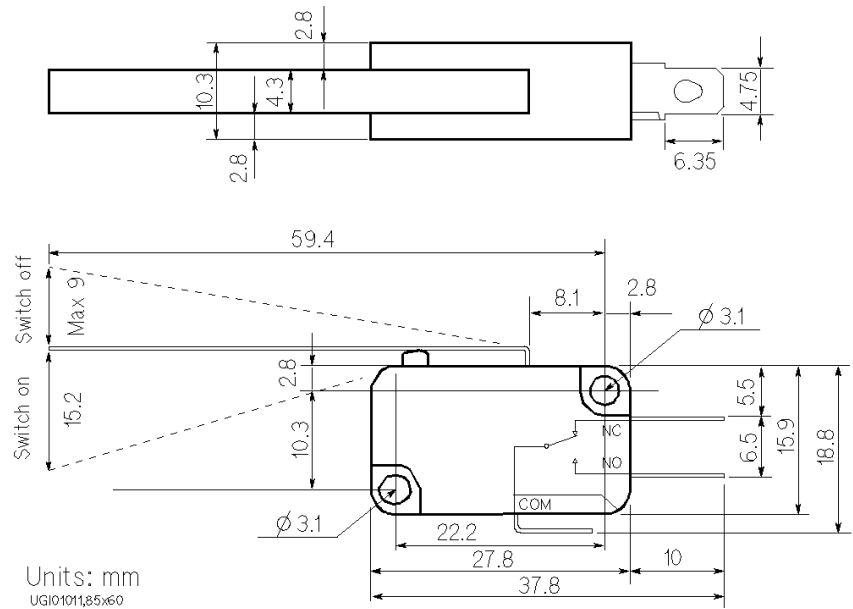
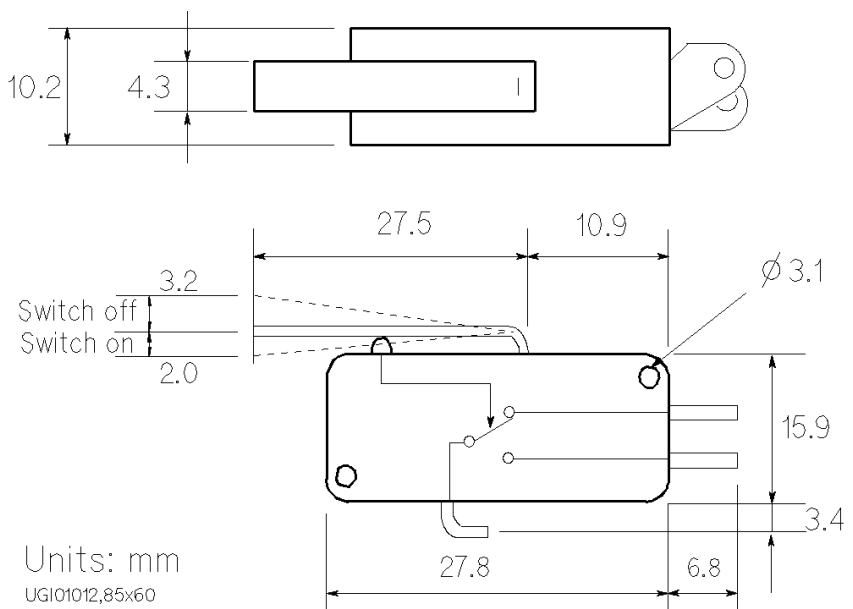

Figure 4-4

Dimensions of Interlock Switch (Agilent part number 3101-3241)



Setting up Measurement Environment Mounting Connectors Directly

To Install LED Circuit

The 4155/4156 semiconductor parameter analyzer's Intlk connector provides the interlock signal and a LED drive signal.

If a LED is connected between pin 4 and pin 5 (or 6) of the interlock connector, the LED lights to indicate *high voltage output* when more than ± 40 V is forced from an SMU in the 4155/4156.

To install LED circuit on your shielding box, do following:

1. Mount LED on your shielding box. For the dimensions of the LED, refer to Figure 4-5.
2. Use wire to connect the LED between pin 4 and pin 5 (or 6) of the interlock connector. Refer to Figure 4-2.

Figure 4-5

Dimensions of LED (Agilent part number 1450-0641)

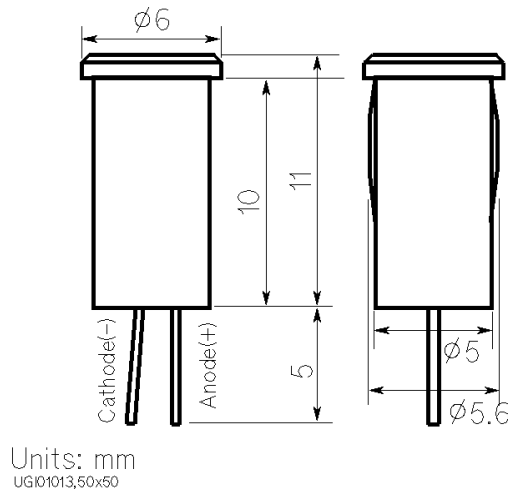

To Connect Interlock Circuit to Instrument

Before beginning the measurement, connect the interlock circuit to the interlock connector of the instrument as follows.

- For Agilent 4155/4156 semiconductor parameter analyzer:

Connect Intlk connector of the 4155/4156 to the interlock connector by using Agilent 16493J Interlock cable that is furnished with the 4155/4156. You can connect it directly without using any adapter.

- For the instruments which has a BNC-Type interlock connector:

If you use an instrument that has a BNC-type interlock connector (such as Agilent 4142B), connect interlock connectors of instrument and the interlock circuit as follows:

Required Parts:

Agilent Model No.	Quantity	Description
16435A	1	Interlock Cable Adapter
16493J	1	Interlock Cable

Procedure:

1. Connect interlock connector of instrument to the BNC connector of the 16435A (interlock cable adapter) by using the BNC cable that is furnished with the adapter.
2. Connect the 16435A adapter to the interlock connector by using the 16493J Interlock cable.

Setting up Measurement Environment Mounting Connectors Directly

NOTE

To Check Interlock Circuit

If you use the 4155/4156, you can easily check the interlock circuit as follows:

1. Connect the Intlk connector of the 4155/4156 to your interlock circuit.
2. Press **System** front-panel key, then select CALIB/DIAG primary softkey to display the SYSTEM: SELF-CALIBRATION/DIAGNOSTICS page.
3. In the CALIB/DIAG field, select DIAG secondary softkey.
4. In the CATEGORY field, select I/O PERIPH secondary softkey.
5. Move pointer to the 403 (INT.) Interlock LED field.
6. Select EXECUTE secondary softkey.
7. Confirm the following:
 - LED turns on within 1 sec from when interlock circuit is shorted.
 - LED turns off within 1 sec from when interlock circuit is open.

To stop the interlock test, select STOP secondary softkey.

To Connect Connectors to DUT

Following figure shows a connection example from the connector to DUT. Use low-noise coaxial cable (Agilent part number: 8121-1191).

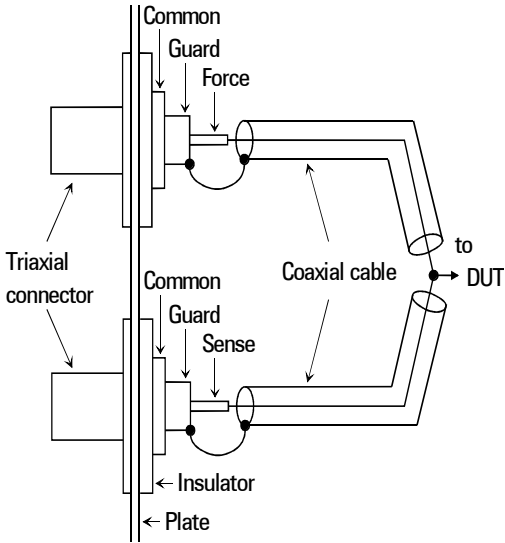
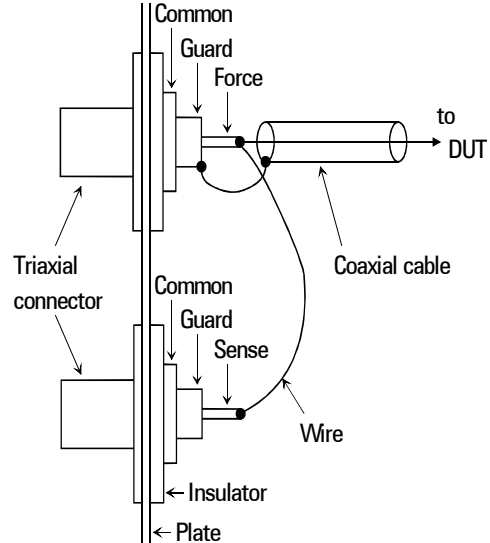
Kelvin connections	non-Kelvin connections
<p>This connection is available only for the Kelvin connectors. This connection can cancel effects of cable resistance by connect sense line and force line as close as possible to DUT terminal.</p>	<p>Following connection is for the Kelvin connectors. For the triaxial connectors or the 8 ch shielded connectors, ignore SENSE terminal, and make connection only for FORCE terminal. Measurement results include residual resistance from the connection cable.</p>
 <p>The diagram shows a Kelvin connector with terminals labeled Common, Guard, Force, and Sense. A triaxial connector is connected to the Kelvin connector. Two coaxial cables are connected to the Force and Sense terminals, with their other ends connected to the DUT. The Force and Sense lines are connected very close to the DUT terminal. Labels include: Triaxial connector, Common, Guard, Force, Coaxial cable, to DUT, Sense, Insulator, and Plate.</p>	 <p>The diagram shows a Kelvin connector with terminals labeled Common, Guard, Force, and Sense. A triaxial connector is connected to the Kelvin connector. A coaxial cable is connected to the Force terminal, and its other end is connected to the DUT. A wire is connected to the Sense terminal. Labels include: Triaxial connector, Common, Guard, Force, Coaxial cable, to DUT, Sense, Wire, Insulator, and Plate.</p>

CAUTION

Never connect the guard terminal to any output, including circuit common, chassis ground, or the guard terminal of any other unit. Doing so may result in an emergency condition.

Setting up Measurement Environment Mounting Connectors Directly

For highly accurate current forcing and measurements while minimizing leakage, surround all force and sense lines from SMU by a guard as far as possible, and make cables stable by taping.

For reducing capacitance measurement error, tape the cables to any grounded materials such as shielding box. If you use probe card, grounding the probe card also reduces capacitance measurement error.

NOTE

Low-Noise Coaxial Cable

When you make a SMU output connection by using low-noise coaxial cable (Agilent part number: 8121-1191), shave the Conductive layer and the Insulator (clear) by knife so that the Center Conductor is insulated from the Conductive layer. Refer to following figure.

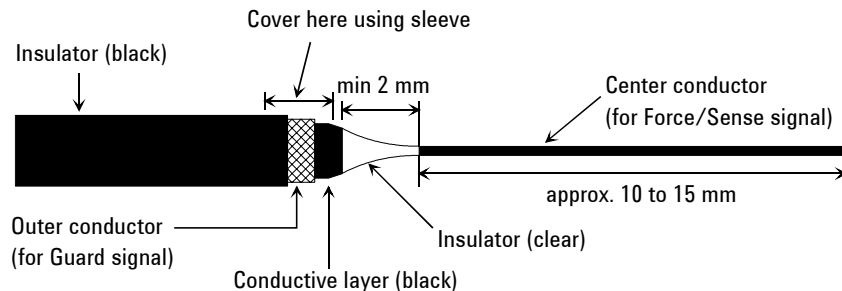

Connecting the E5250A Input

This section explains how to connect instruments to the E5250A.

- “To Connect Instruments to Input Connectors”
- “To Connect Bias Source to the E5255A Bias Input”
- “To Connect GNDU to the E5250A Input”

WARNING

Turn off all instruments that will be connected to the E5250A. And do not turn them on until the connection described in this section is completed. If you ignore this warning, you may be exposed to dangerous voltage.

To Connect Instruments to Input Connectors

The E5250A input connector has six SMU input connectors and four AUX input connectors.

Table 4-3 shows cables required to connect the instrument for typical applications using the E5250A.

You can make Kelvin connections when using the 4156 HRSMU, 41501 HPSMU, 4142B SMU, E5270 SMU. Use cables as follows:

- 4156/41501: Agilent 16494B-003 Kelvin triaxial cable
- 4142B: Agilent 16494C-001 Kelvin triaxial cable
- E5270: Agilent 16494B-001 Kelvin triaxial cable

To connect Kelvin triaxial cable to the E5250A input, use pairs (couple ports) of SMU INPUT connectors (1&2, 3&4, or 5&6) of the E5250A.

The input signal for each Kelvin input is as follows:

- Odd input port number: FORCE
- Even input port number: SENSE

Setting up Measurement Environment
Connecting the E5250A Input

Table 4-3 E5250A Input Connections

Application	Instrument		E5250A Input Connector	Cable Required
	Agilent Model No.	Output Connector		
DC Measurement	4155	MPSMU	SMU1 to 6	16494A-003 Triaxial cable
		VSU	AUX1 to 4	BNC cable
		VMU	AUX1 to 4	BNC cable
		Intlk	–	16493J Interlock cable (for direct connection to Connector Plate)
	4156	HRSMU	SMU1 to 6	16494B-003 Kelvin Triaxial cable or 16494A-003 Triaxial cable
		VSU	AUX1 to 4	BNC cable
		VMU	AUX1 to 4	BNC cable
		Intlk	–	16493J Interlock cable (for direct connection to Connector Plate)
	41501	HPSMU	SMU1 to 6	16494B-003 Kelvin Triaxial cable or 16494A-003 Triaxial cable
		MPSMU	SMU1 to 6	16494A-003 Triaxial cable
		PGU	HF1 or 2	BNC cable
		GNDU	SMU1 to 6	16493H GNDU cable and E5250-60004 Adapter
			–	16493H GNDU cable (for direct connection to Connector Plate)
	4142B	SMU	SMU1 to 6	16494C-001 Kelvin Triaxial cable or 16494A-001 Triaxial cable
		VSU	AUX1 to 4	BNC cable
		VMU	AUX1 to 4	BNC cable
		GNDU	SMU1 to 6	16493H GNDU cable and E5250-60044 Adapter
			–	16493H GNDU cable (for direct connection to Connector Plate)
		Intlk	–	16435A Interlock cable adapter and 16493J Interlock cable (for direct connection to Connector Plate)

Application	Instrument		E5250A Input Connector	Cable Required
	Agilent Model No.	Output Connector		
C Measurement	C Meter	High, Low	CV1 and 2	BNC cable
Pulse Input	Pulse Generator	OUTPUT	HF1 or 2	BNC cable
Bias Input	Power Supply	OUTPUT	AUX1 to 4	BNC cable

In the table above,

- AUX means CV1, CV2, HF1, or HF2 connector.
- The E5250A does not have input connectors for the interlock. Connect directly from instrument to the connector plate which has an interlock connector.
- Can't use Agilent 41422A/41423A (HCU/HVU) of the 4142B with the E5250A.
- To connect instrument output that uses banana plug to AUX connector, use Dual Banana plug to BNC Adapter (Agilent part number 1251-2277).

Figure 4-6 shows an example of connecting the E5250A to the 4156.

Figure 4-6 Connection Example with Agilent 4156

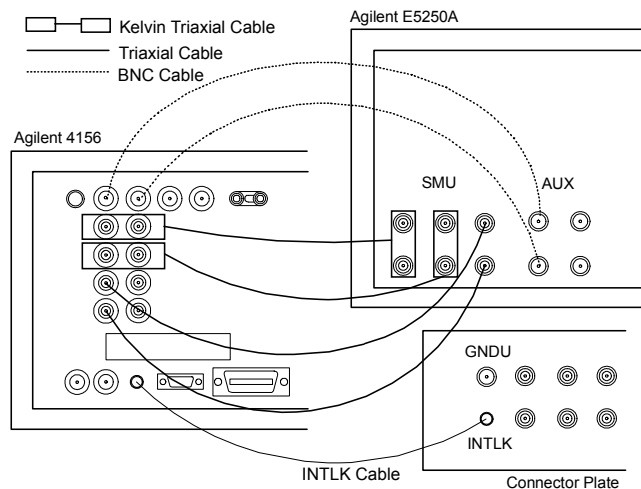

To Connect Bias Source to the E5255A Bias Input

The E5255A BIAS INPUT connector is a BNC-type connector.

Use BNC cable to connect the bias source to the BIAS INPUT of the E5255A.

If output terminal of the bias source is a banana plug, use a Dual Banana Plug to BNC Adapter (Agilent part number 1251-2277).

To Connect GNDU to the E5250A Input

Ground Unit (GNDU) of Agilent 4142B Modular DC Source/Monitor or Agilent 41501 Expander (for Agilent 4155/4156) is usually connected to GNDU connector on the connector plate by using Agilent 16493H GNDU cable. This connection allows current over 1A.

If you want to connect the GNDU through the E5250A to connector plate, test fixture or DUT, connect the GNDU to the E5250A input as shown below.

CAUTION

Make sure current to GNDU is less than 1 A if you connect GNDU to the E5250A. The maximum input current of the E5250A is 1A.

Required Parts:

Agilent Model/Part No.	Quantity	Description
16493H	1	GNDU Cable
E5250-60044	1	Triaxial to Dual Triaxial Adapter

Procedure:

1. Connect the adapter to the E5250A SMU INPUT connector (1&2, 3&4 or 5&6) as shown in Figure 4-7.
2. Connect the GNDU cable between the instrument GNDU connector and the triaxial connector on the adapter.

Figure 4-7

Connection of Triax-Dual Triax Adapter

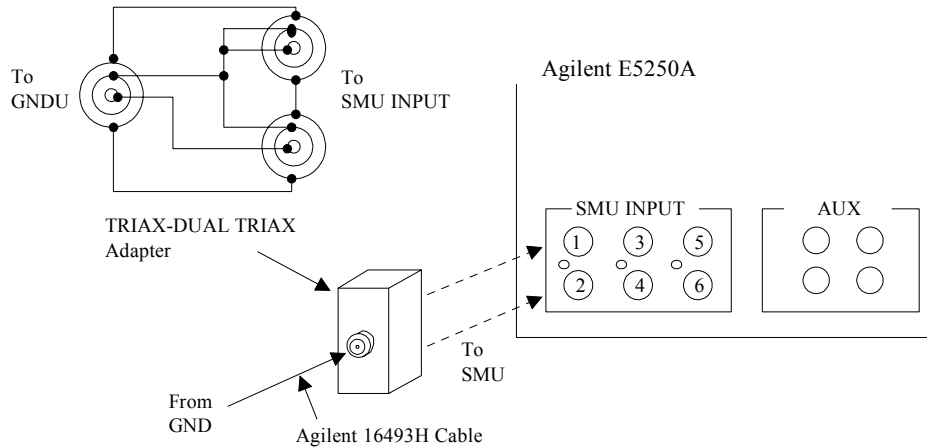

By this connection, input signal for SMU INPUT connectors is as follows:

SMU INPUT Port Number	Input Signal
1, 3, or 5	Force
2, 4, or 6	Sense

If you make non-Kelvin connection for the E5250A outputs, use the odd input port only. Because non-Kelvin connection uses only Force signal for measurement.

Connecting the E5250A Output

This section describes how to connect the E5252A and E5255A output to connector plate, your test fixture, and so on.

- “To Connect the E5252A Output”
- “To Connect the E5255A Output”

WARNING

Turn off the E5250A and all instruments connected to the E5250A. And do not turn them on until the connection described in this section is completed. If you ignore this warning, you may be exposed to dangerous voltage.

To Connect the E5252A Output

The E5252A output connector is shown in Figure 4-8. The E5250A input (SMU input and AUX input) appears at the E5252A output connector as shown in Figure 4-8 when input-output switching path is made. Figure 4-8 shows signals appear on the E5252A output connectors with non-Kelvin connection. If you make Kelvin connection, the signal of the even output connectors is Sense, not Force.

Figure 4-8 E5252A Output Connector and Output Signal

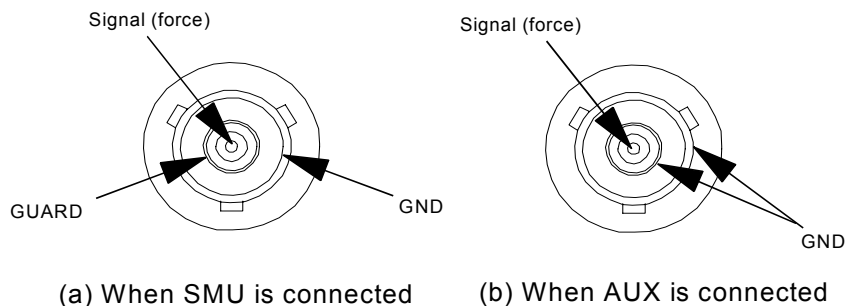

You can easily connect the E5252A output connector to the connector plate or your test fixture by using cables shown in Table 4-4.

Table 4-4 E5252A Output Cable

Agilent Model No.	Description
16494A-001	Triaxial cable, 1.5m (for non-Kelvin connection)
16494A-002	Triaxial cable, 3m (for non-Kelvin connection)
16494B-001	Kelvin Triaxial cable, 1.5m (for Kelvin connection)
16494B-002	Kelvin Triaxial cable, 3m (for Kelvin connection)

For Kelvin connection, use Kelvin triaxial cable listed in Table 4-4. To make a Kelvin output port (1, 3, 5, 7, 9 and 11), couple two E5252A output ports as follows:

Kelvin Output Port	Output Port Number
1	1 (Force) and 2 (Sense)
3	3 (Force) and 4 (Sense)
5	5 (Force) and 6 (Sense)
7	7 (Force) and 8 (Sense)
9	9 (Force) and 10 (Sense)
11	11 (Force) and 12 (Sense)

Figure 4-9 shows the 16494B Kelvin triaxial cable for the E5252A.

Figure 4-9 16494B Kelvin Triaxial Cable for E5252A

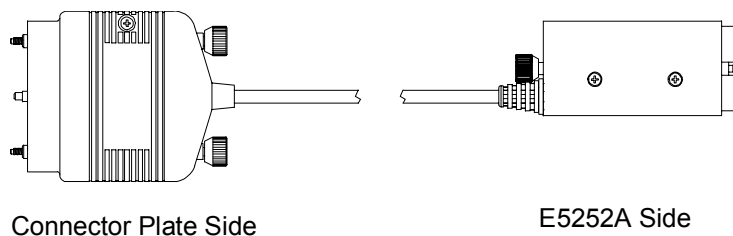

To Connect the E5255A Output

The E5255A output connector is shown in Figure 4-10. The E5250A SMU INPUT signal or the E5255A BIAS INPUT signal appear at the E5255A output connectors as shown in Figure 4-10 when input-output switching path is made. The Kelvin connection is not available for the E5255A.

Figure 4-10

E5255A Output Connector and Output Signal

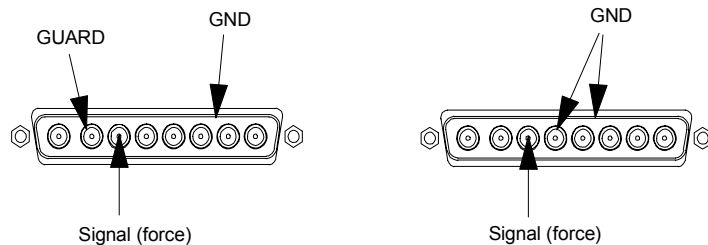

(a) When SMU is connected

(b) When BIAS is connected

You can easily connect the E5255A output to the connector plate or your test fixture by using the cable shown in Table 4-5 and Figure 4-11. The cable can be connected to the E5255A output ports labeled as 1–8, 1–8 (9–16), or 1–8 (17–24).

Table 4-5

E5255A Output Cable

Agilent Model No.	Description
16494D-001	8-Ch Shielded Coaxial cable, 1.5m
16494D-002	8-Ch Shielded Coaxial cable, 3m

Figure 4-11

16494D 8-Channel Shielded Coaxial Cable for E5255A

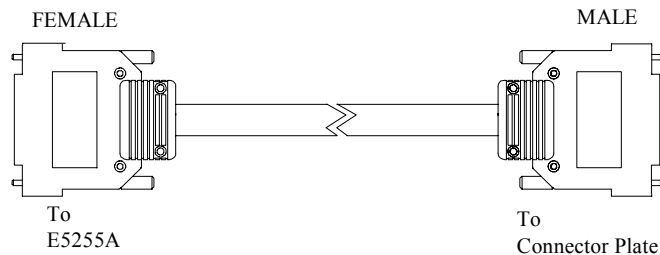

Measurement Cable Length

This section describes how to calculate the total guard capacitance when using a Source Monitor Unit (SMU), such as in Agilent 4155/4156 Semiconductor Parameter Analyzer, Agilent 4142B Modular DC Source/Monitor, Agilent E5270 Series of Parametric Measurement Solution, and so on.

When using an SMU, the length of measurement cables is limited by the guard capacitance of the cables. Guard capacitance means the capacitance between the signal line (FORCE or SENSE) and the GUARD line.

Table 4-6 lists the guard capacitance for each element of the E5250A measurement environment.

When using the 4155/4156/4142B/E5270, the maximum limit of the guard capacitance is approximately 900 pF. So, you add the following and total must be less than 900 pF:

- Guard capacitance of cable from SMU to E5250A SMU INPUT.
- Guard capacitance of E5250A and installed plug-in cards.
- Guard capacitance of cable from plug-in card output to connector plate.
- Guard capacitance of cable from connector plate to DUT.
- Other capacitances, such as for probe card.

The following is an example to calculate the guard capacitance of a measurement environment:

Installed Plug-in cards: Four E5252A cards (145 pF + 8 pF × 3)

Input Cable: 16494A-003 (75 pF)

Output Cable: 16494A-001 (125 pF)

Cable from Connector

Plate to DUT: 8121-1191, 2 m (130 pF × 2)

Probe Card: Guard Capacitance approximately 10 pF (example)

In this environment, the total guard capacitance ($C_{g-total}$) is as follows.

$$C_{g-total} = 145 + (8 \times 3) + 75 + 125 + (130 \times 2) + 10 \text{ pF} = 639 \text{ pF} < 900 \text{ pF}$$

Even if you use other instruments, you can use the table for reference about the measurement cable length and capacitance.

Setting up Measurement Environment
Measurement Cable Length

Table 4-6

Guard Capacitances of E5250A Measurement Environment (Typical)

Connection	Agilent Model/Part No.	Cable Length	Guard Capacitance
from SMU to E5250A	16494A-003 (for non-Kelvin)	80 cm	75 pF
	16494B-003 (for Kelvin)	80 cm	90 pF
	16494C-001 (for 4142B)	1.5 m	140 pF
E5250A and Plug-in Card	E5252A (only 1 card is installed)	–	145 pF
	E5252A (more 1 card)	–	8 pF/extra card
	E5255A (only 1 card is installed)	–	180 pF
	E5255A(more 1 card)	–	60 pF/extra card
from Card Output to Connector Plate	16494A-001 (for non-Kelvin)	1.5 m	125 pF
	16494A-002 (for non-Kelvin)	3 m	240 pF
	16494B-001 (for Kelvin)	1.5 m	140 pF
	16494B-002 (for Kelvin)	3 m	260 pF
	16494C-001 (for 4142B)	1.5 m	140 pF
	16494C-002 (for 4142B)	3 m	260 pF
	16494D-001	1.5 m	125 pF
	16494D-002	3 m	240 pF
	16494E-003	3 m	240 pF
from Connector Plate to DUT	Agilent Part No. 8121-1191	X m	130 pF per m

Controlling the E5250A

This chapter explains how to control Agilent E5250A.

- “Methods for Controlling the E5250A” introduces several methods for controlling the E5250A.
- “Switch Control Basics” introduces basic information for controlling the relay switches on the E5252A and E5255A plug-in cards.
- “Using Virtual Front Panel Utility” describes how to use Virtual Front Panel (VFP) utility furnished with the E5250A. The VFP is for Agilent 4155/4156 users.

Methods for Controlling the E5250A

This section introduces several methods for controlling the E5250A. Table 5-1 lists the E5250A control methods, and the operating systems on which each control method can be used.

Table 5-1 Summary of Control Methods

Control Method	Operating System (Controller)				Refer to
	HP BASIC (workstation)	RMB/UX (workstation)	BASIC for Windows (PC)	IBASIC (4155/4156)	
Creating Your Program	Yes	Yes	Yes	Yes	Chapter 6 and 7
Modifying Sample Program	Yes	No	No	No	Chapter 6, 7, and 8
Using VFP	No	No	No	Yes	page 5-25

Creating Your Own Program

You can create a control program using the SCPI Commands described in Chapter 7 on all the operating systems listed in Table 5-1. Refer to Chapter 6 for how to create the program.

In an control program (which runs on HP BASIC operating system), you can use the Capacitance Compensation Routine and the VFP Data Upload Library furnished with the E5250A.

Capacitance Compensation Routine

This routine is an subprogram runs on HP BASIC, and is used to compensate for the capacitance measurement error caused by the E5250A when the E5252A is installed. This subprogram is used with Agilent 4284A Precision LCR Meter. You enter the capacitance data measured by the 4284A, and this subprogram returns the compensated value.

To use this subprogram, link it to your program. For details, refer to Chapter 6.

VFP Data Upload Library

This subprogram library is used to convert the control data created by the Virtual Front Panel (VFP) Utility to data that can be used with your program runs on HP BASIC. To use this library, link it to your program. For details, refer to Chapter 6.

CAUTION

Open or close the relay without allowing the output voltage to affect the relay by using the following procedure.

1. Disable the output voltage of bias source
2. Connect the relay
3. Enable the output voltage of bias source
4. Make measurements
5. Disable the output voltage of bias source
6. Disconnect the relay

If the relay is opened and output voltage reaches the relay, the relay may be damaged or its service life reduced.

Modifying a Sample Program

The sample programs furnished with the E5250A are useful for creating your program on HP BASIC. You can create your desired program easily by modifying a sample program. To understand the sample programs and how to modify, refer to Chapter 9.

Also, you can use the Capacitance Compensation Routine and the VFP Data Upload Library introduced in “Creating Your Own Program” on page 5-3.

Using the Virtual Front Panel (VFP) Utility

The Virtual Front Panel (VFP) Utility is used to control the E5250A by using Agilent 4155/4156 Semiconductor Parameter Analyzer's built-in Instrument BASIC (IBASIC) controller. You can control the E5250A interactively without the control program.

Refer to “Using Virtual Front Panel Utility” on page 5-25.

Switch Control Basics

This section introduces basic information for controlling the relay switches on the E5252A and the E5255A.

- “Channel List and Channel Configuration”
- “Connection Rule”
- “Connection Sequence”
- “Bias Mode”
- “Couple Port”
- “E5252A Channel List”
- “E5255A Channel List”

Channel List and Channel Configuration

Some SCPI commands require the *channel_list* parameter, which determines the relays to close/open in the E5252A or the E5255A to connect/disconnect the desired channels. The following figure shows the basic syntax of the *channel_list* parameter.

Figure 5-1

Syntax of *channel_list* Parameter

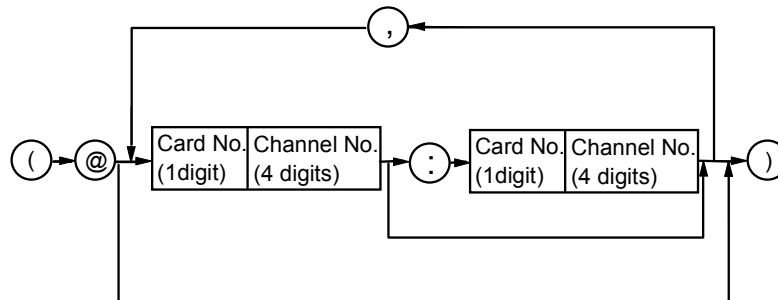

The *channel_list* depends on Channel Configuration mode as described later. In the *channel_list*, you can specify one or more channels.

Each specified channel consists of five digits as follows:

Card Number: One digit decimal number: 0 to 4.

Specifies the slot number of the card that you want to control.
Depends on Channel Configuration mode. Refer to Table 5-2.

Channel Number: Four digit decimal number:

First two digits: specifies input port.

Last two digits: specifies output port.

Depends on type of card and Channel Configuration mode.

Refer to “E5252A Channel List” on page 5-15 and “E5255A Channel List” on page 5-19.

Table 5-2 **Card Number**

Channel Configuration you specified	Slot No. Card is Installed	Card No.
Normal Configuration	1	1
	2	2
	3	3
	4	4
Auto Configuration	1 to 4	0

In the *channel_list*, you can specify multiple channels by using comma (,) or colon (:) as follows:

Comma: use between each specified channel as in following examples:

- (@10101, 10102, 10103) means 10101, 10102 and 10103.
- (@10112, 10202) means 10112 and 10202.
- (@11010, 20102) means 11010 and 20102.

Colon: use to specify a range of channels as in following examples:

- (@10101:10103) means 10101, 10102, and 10103.
- (@10112:10202) means 10112, 10201, and 10202.
- (@11012:20102) means 11012, 20101, and 20102.

As shown in last two examples, you can specify a range across input ports and card slots.

NOTE

In the Auto Configuration mode, you can omit any zeros at beginning of channel. For example, channel 00101 can be expressed by 101.

Channel Configuration

The E5250A allows the following two channel configuration modes. The way to specify the *channel_list* depends on the channel configuration mode. You can set the channel configuration by using the [:ROUT]:FUNC command described in Chapter 7.

Normal

Configuration Default mode at Power On or *RST command.

Each card is considered independently. For each channel in *channel_list*, you specify actual card number and channel number (input port number and output port number).

Auto

Configuration To use this mode, the same type of card must be installed in the E5250A slots from slot number 1 continuously (slots 1,2; or slots 1,2,3; or slots 1,2,3,4).

The installed cards are treated as one card for the output ports. For example, if the E5252As are installed in slots 1,2,3, you can specify output ports 1 to 36.

For each channel in *channel_list*, card number is always 0. For channel number, you specify the input port number and output port number depending on the type of card.

For more information, refer to “E5252A Channel List” on page 5-15 and “E5255A Channel List” on page 5-19.

Connection Rule

Connection rule is used to specify if an input or output port can have multiple connections, and it is specified by the [:ROUte]:CONNECTION:RULE command described in Chapter 7. For each card installed in the E5250A (for auto configuration mode, installed cards are treated as one card), you can specify one of the following connection rules:

Single Route: Each input port can be connected to *only one* output port, and each output port can be connected to *only one* input port. So, existing connection to a port must be disconnected when a new connection is made.

If normal configuration mode is set to the E5250A with multiple cards, an input/output path is effective for each card. For example, if normal configuration mode is set to the E5250A with two E5252As, and single route is set to both cards, the following connection is possible.

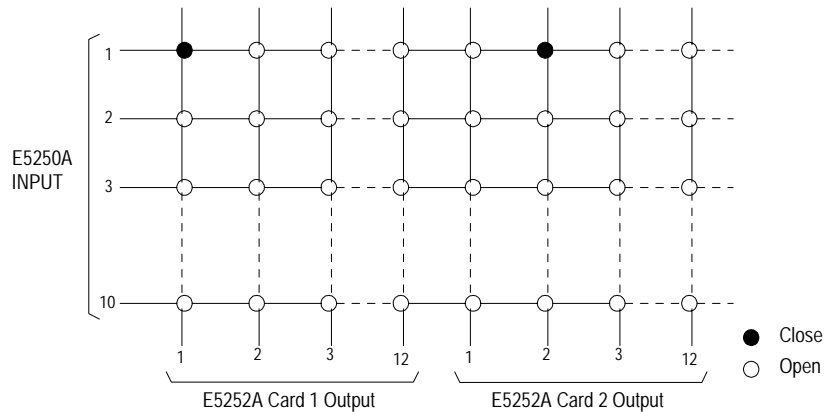

Free: Each input port can be connected to *multiple* output ports, and each output port can be connected to *multiple* input ports.

CAUTION

If the Free connection rule has been specified, ensure multiple input ports are not connected to the same output port. Such configurations can cause damage.

Connection Sequence

NOTE

This is only for cards that are set to the Single Route connection rule. Refer to “Connection Rule” on page 5-9.

Connection sequence specifies the open/close sequence of the relays when changing from an existing connection to a new connection. You can specify the connection sequence by using the [:ROUTE]:CONNECTION:SEQUENCE command described in Chapter 7.

You can select one of the three connection sequences shown in Table 5-3 for each card installed in the E5250A.

When an existing connection is changed to a new connection, the relays are opened/closed as follows:

Table 5-3

Connection Sequence

Connection Sequence	Relay Operation
Break Before Make	<ol style="list-style-type: none">1. Disconnect previous route.2. Wait for relays to open.3. Connect new route.
Make Before Break	<ol style="list-style-type: none">1. Connect new route.2. Wait for relays to close.3. Disconnect previous route.
No Sequence	<ol style="list-style-type: none">1. Disconnect previous route.2. Connect new route.

Bias Mode

NOTE

Connection rule cannot be specified for the input Bias Port, which can always be connected to multiple output ports.

Connection sequence (to connect input Bias Port to output ports) is always Break-Before-Make.

Bias Port and Couple Port cannot be set to the same port number.

Bias Mode is effective for the input Bias Port:

- For the E5255A, input Bias Port is the dedicated BIAS port on the E5255A
- For the E5252A, input Bias Port is the input port (1 to 10) that you select.

When Bias Mode is ON, the input Bias Port is connected to all *bias enabled* output ports that are not connected to any other input ports. You cannot directly control which output ports are connected to the input Bias Port:

- If another input port is disconnected (:ROUT:OPEN command) from a *bias enabled* output port, the output port is automatically connected to the input Bias Port.
- If another input port is connected (:ROUT:CLOS command) to a *bias enabled* output port, the output port is automatically disconnected from the input Bias Port.

Bias disabled output ports are never connected to the input Bias Port when Bias Mode is ON.

When Bias Mode is OFF, the input Bias Port is the same as the other input ports, so relays can be controlled directly to connect to output ports.

You can independently control the Bias Mode for each card installed in the E5250A. Refer to [:ROUTE]:BIAS[:STATE] in Chapter 7.

For a programming example, refer to Chapter 6.

Controlling the E5250A Switch Control Basics

Figure 5-2

Example of Bias Mode

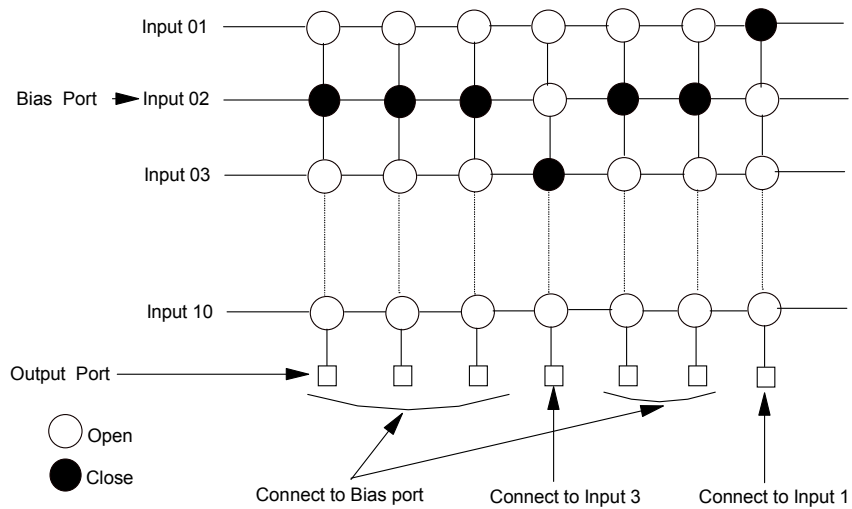

Figure 5-2 shows an example. Input port 2 is the input Bias Port. When the Bias Mode is turned ON, all bias enabled output ports (that are not connected to other input ports) are connected to the input Bias Port. So, the output ports that are connected to input port 1 and 3 are not connected to the input Bias Port.

Couple Port

NOTE

This function is available only for the E5252A.

Bias Port and Couple Port cannot be set to the same port number.

This function is used for making Kelvin connections. Couple port allows synchronized connection of two adjacent input ports to two adjacent output ports. You set up the Couple Port by using the [:ROUTe]:COUPlE:PORT command described in Chapter 7.

To turn Couple Port mode ON/OFF, refer to [:ROUTe]:COUPlE[:STATe] command in Chapter 7.

For a programming example, refer to Chapter 6.

The input ports 1 and 2, 3 and 4, 5 and 6, 7 and 8, or 9 and 10 can be coupled together. See Table 5-4. For example, if you specify input port number 1 in the [:ROUTe]:COUPlE:PORT command, input ports 1 and 2 are coupled together.

Table 5-4

Couple Port Number and Output Port Number

Couple Port No.	Input Ports	Available Output Port No.
01	SMU1, SMU2	01 to 12 (for Normal Config.) 01 to 48 (for Auto Config.)
03	SMU3, SMU4	01 to 12 (for Normal Config.) 01 to 48 (for Auto Config.)
05	SMU5, SMU6	01 to 12 (for Normal Config.) 01 to 48 (for Auto Config.)
07	HF1, HF2	01 to 12 (for Normal Config.) 01 to 48 (for Auto Config.)
09	CV1, CV2	01 to 12 (for Normal Config.) 01 to 48 (for Auto Config.)

Controlling the E5250A Switch Control Basics

The two output ports are determined by the *channel_list* parameter of the :ROUT:CLOS command, and the lower output port number is always odd.

So, when you execute :ROUT:CLOS or :ROUT:OPEN command for the couple port, four relays operate synchronously as shown in Figure 5-3.

For example, assume that input ports 1 and 2 are coupled, and that the Couple Port mode is ON:

1. If :ROUT:CLOS command specifies to connect channel 0105, relays are closed to realize two channels (0105 and 0206).
2. If :ROUT:OPEN command specifies to disconnect channel 0105, all four relays between the two input ports and two output ports are opened.

Figure 5-3 Couple Port Relay Connections

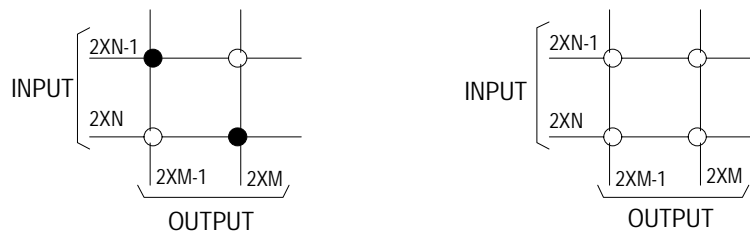

1. Connect condition

2. Disconnect condition

- Close
- Open

N=1 to 5
M=1 to 6 for Normal Config.
M=1 to 24 (max) for Auto Config.

NOTE

For each E5252A installed in the E5250A, you can independently specify the same or different couple ports.

E5252A Channel List

This section describes how to define the *channel_list* specifically for the E5252A.

For the basic syntax of the *channel_list*, see “Channel List and Channel Configuration” on page 5-6.

Normal Configuration Mode

To specify a channel, you use five digits as shown in Table 5-5.

Table 5-5 Specifying E5252A Channels in Normal Config. Mode

Slot No. (E5252A is installed)	One Channel: 5 digits		
	Card Number (first 1 digit)	Channel Number: 4 digits	
		Input Port No. (next 2 digits)	Output Port No. (last 2 digits)
1	1	01 to 10	01 to 12
2	2	01 to 10	01 to 12
3	3	01 to 10	01 to 12
4	4	01 to 10	01 to 12

Card Number: One digit: 1 to 4. E5250A slot number in which card is installed.

Channel Number: Four digits: XXYY.

- XX: input port number (01 to 10).
- YY: output port number (01 to 12).

Channel Number assignment is shown in Figure 5-4.

NOTE

For the following two cases, three ports share one input path. Do not specify two of the input ports at same time.

- SMU5, HF1, and CV1 (Input Port No. 05, 07, and 09)
- SMU6, HF2, and CV2 (Input Port No. 06, 08, and 10)

For example, if you specify input port 05, then you cannot specify input ports 07 and 09. You can specify 05 and 06 at the same time.

Controlling the E5250A
Switch Control Basics

Figure 5-4 E5252A Channel Number in Normal Config. Mode

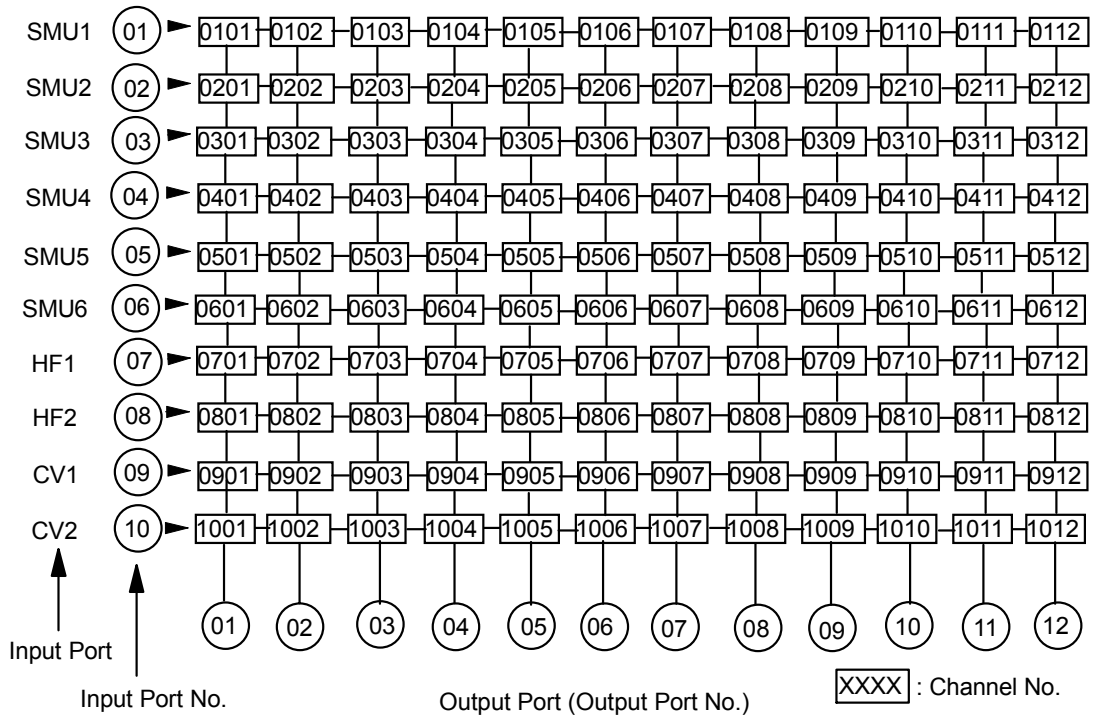

Auto Configuration Mode

To use this mode, the E5252A must be installed in the E5250A slots continuously from slot1 (slots 1,2; or slots 1,2,3; or slots 1,2,3,4).

To specify a channel, you use five digits as shown in Table 5-6.

Table 5-6 Specifying E5252A Channels in Auto Config. Mode

Slot No. (E5252A is installed)	Configuration	One Channel: 5 digits		
		Card Number (first 1 digit)	Channel Number: 4 digits	
			Input Port No. (next 2 digits)	Output Port No. (last 2 digits)
1	10×12 Matrix	0	01 to 10	01 to 12
1 and 2	10×24 Matrix	0	01 to 10	01 to 24
1 to 3	10×36 Matrix	0	01 to 10	01 to 36
1 to 4	10×48 Matrix	0	01 to 10	01 to 48

Card Number: One digit: always 0.

Channel Number: Four digits: XXYY.

- XX: input port number (01 to 10).
- YY: output port number (01 to 48).

Channel Number assignment is shown in Figure 5-5.

In the Auto Configuration mode, you can omit any zeros at beginning of channel. For example, channel 00101 can be expressed by 101.

NOTE

For the following two cases, three ports share one input path. Do not specify two of the input ports at same time.

- SMU5, HF1, and CV1 (Input Port No. 05, 07, and 09)
- SMU6, HF2, and CV2 (Input Port No. 06, 08, and 10)

For example, if you specify input port 05, then you cannot specify input ports 07 and 09. You can specify 05 and 06 at the same time:

Controlling the E5250A
Switch Control Basics

Figure 5-5 E5252A Channel Number in Auto Config. Mode (example for 10×48 matrix)

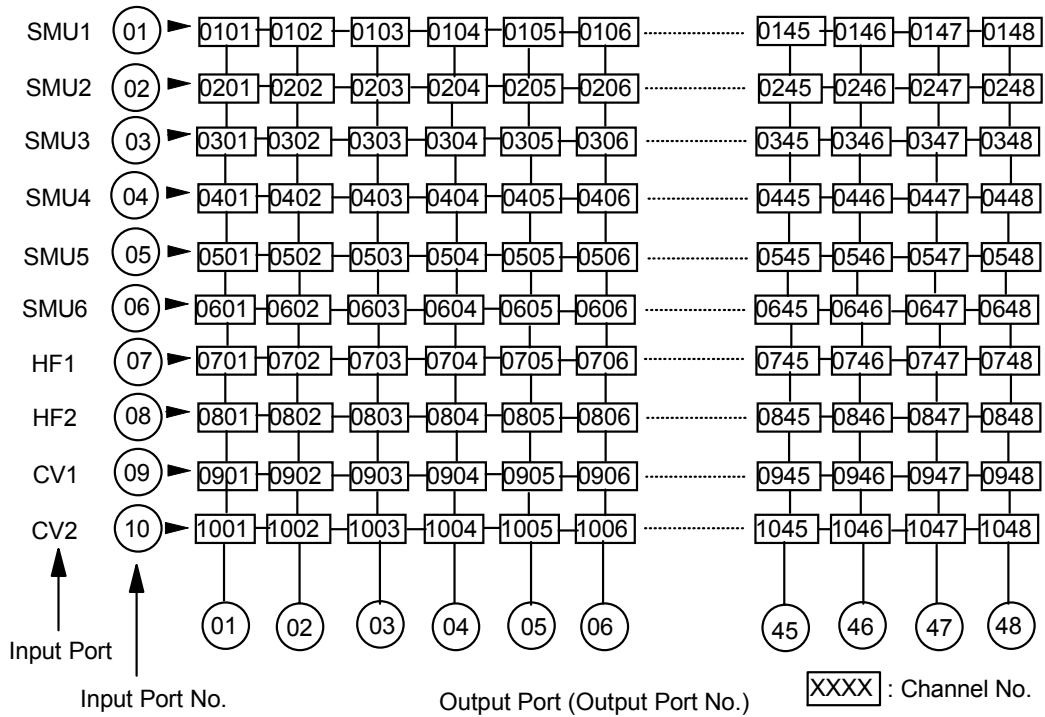

E5255A Channel List

This section describes how to define the *channel_list* specifically for the E5255A.

For the basic syntax of *channel_list* parameter, see “Channel List and Channel Configuration” on page 5-6.

Normal Configuration Mode

To specify a channel, you use five digits as shown in Table 5-7.

Table 5-7 Specifying E5255A Channels in Normal Config. Mode

Slot No. (E5255A is installed)	Block No. of E5255A	One Channel: 5 digits		
		Card Number (first 1 digit)	Channel Number: 4 digits	
			Input Port No. (next 2 digits)	Output Port No. (last 2 digits)
1	1	1	IV Input: 01 BIAS Input: 51	01 to 08
	2		IV Input: 02 BIAS Input: 52	
	3		IV Input: 03 BIAS Input: 53	
2	1	2	IV Input: 01 BIAS Input: 51	01 to 08
	2		IV Input: 02 BIAS Input: 52	
	3		IV Input: 03 BIAS Input: 53	
3	1	3	IV Input: 01 BIAS Input: 51	01 to 08
	2		IV Input: 02 BIAS Input: 52	
	3		IV Input: 03 BIAS Input: 53	
4	1	4	IV Input: 01 BIAS Input: 51	01 to 08
	2		IV Input: 02 BIAS Input: 52	
	3		IV Input: 03 BIAS Input: 53	

Controlling the E5250A Switch Control Basics

Card Number: One digit: 1 to 4. E5250A slot number in which card is installed.

Channel Number: Four digits: XXYY.

- XX: input port number (depends on the block number).
01, 02, or 03 for IV Input Port Number.
51, 52, or 53 for BIAS Input Port Number.

The input port number depends only on the block number, and does *not* depend on which the E5250A SMU Input is connected to the IV Input.

- YY: output port number (01 to 08).

Channel Number assignment is shown in Figure 5-6.

Figure 5-6 E5255A Channel Number in Normal Config. Mode

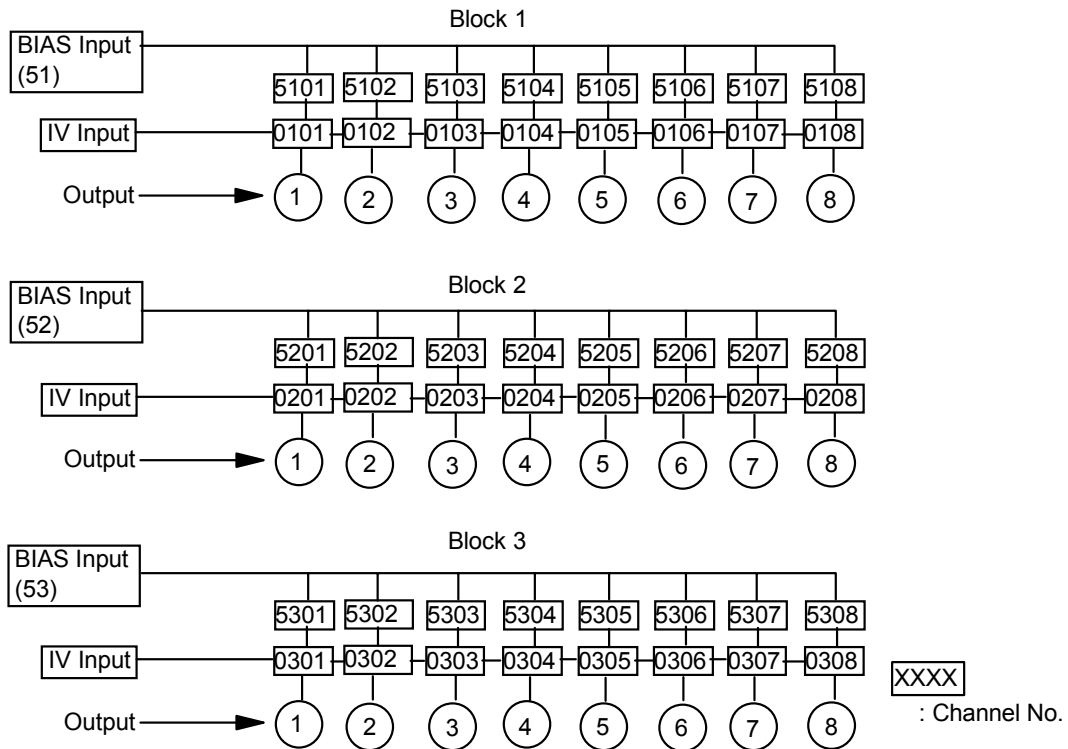

Auto Configuration Mode

To use this mode, the E5255A must be installed in the E5250A slots continuously from slot1 (slots 1,2; or slots 1,2,3; or slots 1,2,3,4). To specify a channel, use five digits as shown in Table 5-8,

Table 5-8

Specifying E5255A Channels in Auto Config. Mode

IV Port Input Connection (SMU Input Port No.)	One Channel: 5 digits		
	Card Number (first 1 digit)	Channel Number: 4 digits	
		Input Port No. (next 2 digits)	Output Port No. (last 2 digits)
to SMU1 (1)	0	IV Input: 01 BIAS Input: 11	01 to 96
to SMU2 (2)	0	IV Input: 02 BIAS Input: 12	01 to 96
to SMU3 (3)	0	IV Input: 03 BIAS Input: 13	01 to 96
to SMU4 (4)	0	IV Input: 04 BIAS Input: 14	01 to 96
to SMU5 (5)	0	IV Input: 05 BIAS Input: 15	01 to 96
to SMU6 (6)	0	IV Input: 06 BIAS Input: 16	01 to 96

Card Number: One digit: always 0.

Channel Number: Four digits: XXYY.

- XX: input port number.
01, 02, 03, 04, 05, or 06 for IV Input Port.
11, 12, 13, 14, 15, or 16 for BIAS Input Port.
- YY: output port number.
Minimum output port number is 01. Maximum output port number is the total number of output ports for the E5255A blocks connected to the same input port.
For each configured multiplexer, output port number 01 is assigned to first output port of smallest block number on card in the lowest slot number.

Controlling the E5250A Switch Control Basics

In the Auto Configuration mode, you can omit any zeros at beginning of channel. For example, channel 00101 can be expressed by 101.

Figure 5-7, Table 5-9 and Figure 5-8 show examples of the Channel Number. In this example, four E5255As are installed in the E5250A. And the E5255As are configured to make the following multiplexers:

- Slot1 and Slot2:
all six blocks are used together to make a 2×48 multiplexer.
IV input port is internally connected to SMU1 input port.
- Slot3 and Slot4:
 - Both Block1 used together to make 2×16 multiplexer-1.
IV input port is internally connected to SMU2 input port.
 - Both Block2 used together to make 2×16 multiplexer-2.
IV input port is internally connected to SMU3 input port.
 - Block3 of Slot3 makes 2×8 multiplexer-1.
IV input port is internally connected to SMU4 input port.
 - Block3 of Slot4 makes 2×8 multiplexer-2.
IV input port is internally connected to SMU5 input port.

For the internal connections of the E5255A, see Chapter 2.

Figure 5-7

Example Setup of E5255A

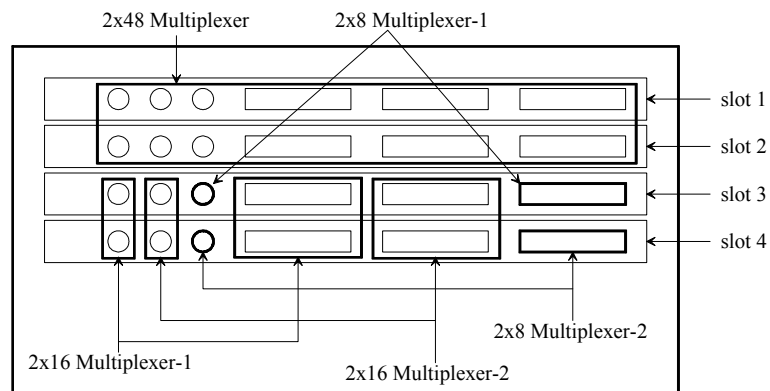
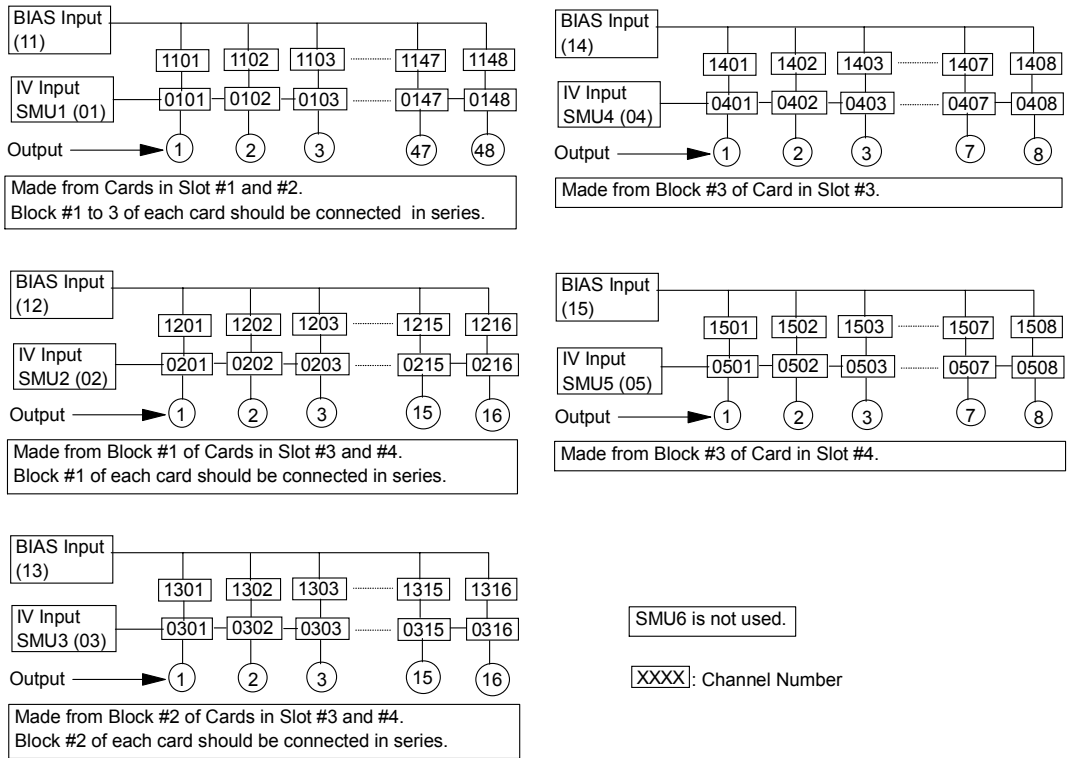

Table 5-9 Example IV Input Connection and Channel Number

Slot No.	Block No.	IV Input to	One Channel: 5 digits			Configuration
			Card Number (first 1 digit)	Channel Number: 4 digits		
				Input Port No. (next 2 digits)	Output Port No. (last 2 digits)	
1	1 to 3	SMU1	0	IV Input: 01 BIAS Input: 11	01 to 24	2×48MUX with slot 2 card
2	1 to 3	SMU1	0	IV Input: 01 BIAS Input: 11	25 to 48	2×48MUX with slot 1 card
3	1	SMU2	0	IV Input: 02 BIAS Input: 12	01 to 08	2×16MUX-1 with block1 in slot 4 card
	2	SMU3	0	IV Input: 03 BIAS Input: 13	01 to 08	2×16MUX-2 with block2 in slot 4 card
	3	SMU4	0	IV Input: 04 BIAS Input: 14	01 to 08	2×8MUX-1
4	1	SMU2	0	IV Input: 02 BIAS Input: 12	09 to 16	2×16MUX-1 with block1 in slot 3 card
	2	SMU3	0	IV Input: 03 BIAS Input: 13	09 to 16	2×16MUX-2 with block2 in slot 3 card
	3	SMU5	0	IV Input: 05 BIAS Input: 15	01 to 08	2×8MUX-2

Controlling the E5250A Switch Control Basics

Figure 5-8 Example for E5255A Channel Number in Auto Config. Mode



Using Virtual Front Panel Utility

The Virtual Front Panel (VFP) Utility is a control program for the E5250A. The VFP utility runs on Agilent 4155/4156 Semiconductor Parameter Analyzer's built-in IBASIC controller. You can control the E5250A interactively from the 4155/4156 by using the VFP utility.

This section describes how to use the VFP utility:

- “Functions of Virtual Front Panel Utility”
- “Requirements”
- “Starting the Virtual Front Panel Utility”
- “Confirming the E5250A Card Configurations”
- “Changing the VFP Setup Mode”
- “Defining Labels for the E5250A Input Ports”
- “Making Connections and Changing the Setup Data”
- “Saving/Loading the Setup Data”

Functions of Virtual Front Panel Utility

The Virtual Front Panel (VFP) utility is used to create the E5250A setup data and interactively (from the 4155/4156) make channel connections on the E5250A plug-in cards. The VFP utility can perform the following:

- Display the E5250A card configurations.
- Change the channel configuration mode, bias port, and bias mode.
- Define labels for the E5250A input terminals.
- Create setup data (connection data).
- Create channels on cards according to the connection data.
- Use 24 different setup memories for one setup data.
- Save/load the setup data to/from a file.

The setup data has 24 setup memories. One setup memory is used for one measurement setup, and is the minimum unit of the E5250A setup data. For example, one setup memory is used for MOSFET V_{th} measurement, another setup memory is used for Capacitance measurement, and so on. One setup memory is used for the connection data of all installed cards.

The data created by the VFP can be saved to diskette by using the built-in flexible disk drive of the 4155/4156. And VFP data on diskette can be loaded into VFP.

Also, the VFP data on diskette can be loaded into your program by using the VFP Data Upload Library. Refer to Chapter 6.

In the VFP, the following are always used and cannot be changed:

- Connection Rule: FREE
- Connection Sequence: Break Before Make
- Couple Port function is not available in the VFP.

Requirements

The following are required to execute the Virtual Front Panel (VFP) Utility.

Model/Part No.	Description	Qty.
4155 or 4156	Semiconductor Parameter Analyzer	1
10833A/B/C	GPIB Cable	1
E5250-17003	E5250A Program Disk (furnished)	1

Starting the Virtual Front Panel Utility

1. Before turning on the E5250A and the 4155/4156 Semiconductor Parameter Analyzer, connect the GPIB cable between the instruments, and make a measurement connection. See Chapter 4.
2. Turn on the 4155/4156 and the E5250A.
3. Set the 4155/4156 to "SYSTEM CONTROLLER" mode on SYSTEM: MISCELLANEOUS page.
4. Insert the E5250A Program Disk into the 4155/4156 disk drive.
5. Press the **Display** key twice to change to "All IBASIC" screen. This key is located in the IBASIC area on the 4155/4156 front panel.
6. Select the GET softkey. This softkey is displayed on right side of the 4155/4156 screen. The following statement is displayed on the 4155/4156.

```
GET "_"
```

7. Type VFP between the double quotations of the GET statement. Then press **Enter** key. Wait until the 4155/4156 finishes getting the file.
8. Press the **Run** key, which in the IBASIC area on the 4155/4156 front panel. The following message is displayed:

```
Input Agilent E5250A GPIB Address (default 722) : ?
```

9. To use default GPIB address 722, just press the **Enter** key.

If not, type the GPIB address of your E5250A, then press **Enter** key.

The main menu of VFP is displayed on the 4155/4156 screen. And the E5250A is initially set to settings of setup memory 1.

Controlling the E5250A Using Virtual Front Panel Utility

The following softkeys are displayed on right side of the 4155/4156 screen.

Softkey	Description
SHOW CONFIG	For confirming which cards are installed in each E5250A slot.
SETUP MODE	For changing the VFP setup mode (Channel Configuration mode, Bias Port, and Bias Mode state). When the setup mode is changed, all setup data is cleared (that is, connection data is set so that all relays are open).
DEFINE LABEL	For defining labels for the E5250A input ports to be used in MEMORY SETUP PANEL.
SETUP MEMORY	For creating connection channels in the E5250A cards. When you modify any setting of the setup memory, the E5250A connection channels are changed in real time.
SAVE/LOAD	For saving/loading the setup data to/from diskette.
QUIT	Quits the VFP utility.

Confirming the E5250A Card Configurations

Select SHOW CONFIG softkey. SHOW CONFIGURATION MENU is displayed on the 4155/4156 to show which card is installed in each E5250A slot.

If card is the E5252A, the following comment is displayed:

```
E5252A 10x12 Matrix Switch
```

If card is the E5255A, a comment similar to following example is displayed:

```
E5255A 24 (8x3) Channel Multiplexer  
Block 1 : Input 1, No Resistance  
Block 2 : Input 2, No Resistance  
Block 3 : Input 3, No Resistance
```

For Input *N*, the *N* can be 1 to 6, and indicates which E5250A SMU input port is connected to the IV input of each multiplexer block. The next parameter indicates if resistor is used between input Bias Port and IV Input ports as follows:

- No Resistance: no resistor used.
- With Resistance: resistor is used.

Changing the VFP Setup Mode

Select the SETUP MODE softkey. The display shows the present setup conditions:

Channel Configuration mode: NORMAL or AUTO

Model Number of each card: E5252A or E5255A

Bias Mode state of each card: ON or OFF

Bias Port number of each card: E5252A: 1 to 10 E5255A: not applicable

The card numbers are 1 to 4 in NORMAL configuration mode, and 0 (zero) in AUTO configuration mode.

The following softkeys are available.

Softkey	Description
CHANGE CONFIG	For changing the channel configuration mode. See next page.
CARDn (n=1 to 4)	For selecting which card to change the Bias Port and Bias Mode state. CARDn softkeys are displayed only in NORMAL configuration mode. Displays the BIAS STATE, BIAS PORT and RETURN softkeys. Select RETURN softkey to display CARDn softkey again, so you can select another card to change the Bias Port and Bias Mode state.
BIAS STATE	For toggling the Bias Mode ON/OFF. This softkey is displayed in AUTO configuration mode, or by selecting the CARDn softkey in NORMAL configuration mode. See next page.
BIAS PORT	Only for the E5252A card. For selecting the Bias Port. This softkey is displayed in AUTO configuration mode, or by selecting the CARDn softkey in NORMAL configuration mode. See next page.
MAIN MENU	For returning to VFP main menu. See next page.

CAUTION

If you change the VFP Setup Mode, all data is cleared from the setup memories when you return to the VFP main menu.

Controlling the E5250A Using Virtual Front Panel Utility

Figure 5-9

Example of SETUP MODE MENU

```
Agilent E5250A Virtual Front Panel Utility
** SETUP MODE MENU **

CONFIG MODE : NORMAL

CARD1 [E5252]      BIAS STATE      BIAS PORT
CARD2 [E5252]      OFF              10
CARD3 [E5255]      OFF              --
CARD4 [E5255]      OFF              --

!! CAUTION !!
  If any setting parameter of this menu is changed,
  all setup memory will be cleared.

Select desired softkey.
```

To change the channel configuration mode

Select the CHANGE CONFIG softkey. This softkey toggles the configuration mode between AUTO and NORMAL.

To change the Bias Port (for the E5252A only)

Select the BIAS PORT softkey. The following message is displayed:

```
Input Bias Port Number.
```

Type input port number (1 to 10 is available) to use as bias port, then press **Enter** key. To cancel operation, press **Enter** key without typing a number.

To change the Bias Mode state

Select BIAS STATE softkey. This softkey toggles the state OFF/ON.

To enter/cancel the changes and return to the VFP main menu

Select MAIN MENU softkey. If you did not make changes, Main Menu is displayed. If you made changes, following message/softkeys are displayed:

```
Changing mode will clear all setup memory. OK?
```

Softkey	Description
CHANGE MODE	Enters the changes you made, and returns to the VFP main menu. All the previous setup memory data is cleared.
CANCEL	Cancels the changes you made, and returns to the VFP main menu. Setup memory data is not cleared.

Defining Labels for the E5250A Input Ports

You can define labels to use for the input ports of each row in the MEMORY SETUP PANEL.

Select the DEFINE LABEL softkey. The DEFINE LABEL MENU and following softkeys are displayed:

Softkey	Description
E5250A INPUT	For displaying softkeys to select the desired input ports. See below.
CARDn INPUT (n=1 to 4)	For selecting the E5255A. You can define a label for the input Bias Port of selected E5255A. This softkey is displayed only for card slots that have the E5255A installed. See next page.
MAIN MENU	For returning to VFP main menu.

To define labels for the E5250A input ports

Select the E5250A INPUT softkey. The following softkeys are displayed.

Softkey	Description
INPUTn LABEL (n=1 to 10)	For selecting the E5250A input port. You can define a label for the selected input port. See below.
MORE	For displaying more softkeys to select the input port. This softkey toggles between the INPUTn LABEL softkeys n=1 to 5 and n=6 to 10.
RETURN	For returning to the DEFINE LABEL MENU.

Select the INPUTn LABEL softkey (n=1 to 10). The following message is displayed:

Input Label Name. (Max 5 char string)

Type desired label (maximum 5 characters), then press the **Enter** key.

If you press the **Enter** key without typing any characters, the label is cleared.

Controlling the E5250A
Using Virtual Front Panel Utility

To define labels for the E5255A bias input ports

Select the CARDn INPUT softkey (n=1 to 4). The following softkeys are displayed:

Softkey	Description
BIASn LABEL (n=1 to 3)	For selecting input Bias Port on the E5255A that was selected by the CARDn INPUT softkey. See below.
RETURN	For returning to the DEFINE LABEL MENU.

Select the BIASn LABEL softkey (n=1 to 3). The following message is displayed:

Input Label Name. (Max 5 char string)

Type desired label (maximum 5 characters), then press the **Enter** key.

If you press the **Enter** key without typing any characters, the label is cleared.

Figure 5-10

Example of DEFINE LABEL MENU

Agilent E5250A Virtual Front Panel Utility

** DEFINE LABEL MENU **

```
E5250A INPUT1 : " IV1 "  
      INPUT2 : " IV2 "  
      INPUT3 : " IV3 "  
      INPUT4 : " IV4 "  
      INPUT5 : " IV5 "  
      INPUT6 : " IV6 "  
      INPUT7 : " HF1 "  
      INPUT8 : " HF2 "  
      INPUT9 : " CV1 "  
      INPUT10 : " CV2 "
```

```
CARD1 E5252A No Bias Input Port  
CARD2 E5252A No Bias Input Port  
CARD3 E5255A BIAS1:"C3B1 " BIAS2:"C3B2 " BIAS3:"C3B3"  
CARD4 E5255A BIAS1:"C4B1 " BIAS2:"C4B2 " BIAS3:"C4B3"
```

Select desired softkey.

Making Connections and Changing the Setup Data

Select SETUP MEMORY softkey. The E5250A is initially set to connections of setup memory 1, then SETUP MEMORY MENU and following softkeys are displayed. *Current Setup Memory* indicates setup memory that currently sets E5250A.

Softkey	Description
NEXT SETUP	Changes Current Setup Memory to next setup memory number. Increases number of <i>Current Setup Memory</i> by 1. And changes the E5250A to new settings.
PREV SETUP	Changes Current Setup Memory to previous setup memory number. Decreases number of <i>Current Setup Memory</i> by 1. And changes the E5250A to new settings.
GOTO SETUP	Changes the E5250A to settings of specified setup memory. See later. Changes <i>Current Setup Memory</i> to specified setup memory number.
MODIFY SETUP	For modifying settings in <i>Current Setup Memory</i> . See later.
MORE	Displays more softkeys. See below table.
MAIN MENU	Returns to the VFP main menu.

Softkey	Description
CLEAR SETUP	For clearing settings of specified setup memory. See later. The setup memory is changed to "Open All" (no connection) setup.
COPY SETUP	For copying a setup memory to another setup memory. See later.
DELETE SETUP	For deleting the specified setup memory. The higher setup memories are shifted down, and setup memory 24 is set to "Open All" (no connection). See later.
INSERT SETUP	For inserting setup memory ("Open All"– no connection) at specified setup memory number. Specified setup and higher memories are shifted up, and setup memory 24 is deleted. See later.
CLEAR ALL	For clearing all setup memories. All setup memories are changed to "Open All" (no connection) setup. See later.
MORE	Displays more softkeys. See above table.
MAIN MENU	Returns to the VFP main menu.

Controlling the E5250A Using Virtual Front Panel Utility

Figure 5-11

Example of SETUP MEMORY MENU

```
Agilent E5250A Virtual Front Panel Utility
```

```
** SETUP MEMORY MENU **
```

```
Current Setup Memory : 1
```

Setup:	Comment	Setup:	Comment
1	: Open All	13	: Open All
2	: MOSFET 1	14	: Open All
3	: MOSFET 2	15	: Open All
4	: MOSFET 3	16	: Open All
5	: MOS CAP 1	17	: Open All
6	: MOS CAP 2	18	: Open All
7	: MOS CAP 3	19	: Open All
8	: Open All	20	: Open All
9	: Open All	21	: Open All
10	: Open All	22	: Open All
11	: Open All	23	: Open All
12	: Open All	24	: Open All

Select desired softkey.

To change the E5250A setup to specified setup memory

Select the GOTO SETUP softkey. The following message is displayed:

```
Input setup memory number to be connected?
```

Type the desired setup memory number, then press the **Enter** key. *Current Setup Memory* changes to the specified setup memory, and the E5250A changes to the new settings.

If you press **Enter** key without typing a number, the operation is canceled.

To copy a setup memory

Select the COPY SETUP softkey. The following message is displayed:

```
Input copy src & dest setup memory number: src,dest
```

Type the desired setup memory number, then press the **Enter** key. This operation overwrites the setup memory data. For example, to copy setup memory No.1 to No.5, type as follows:

```
1, 5
```

If you press **Enter** key without typing numbers, operation is canceled.

To delete a setup memory

Select the DELETE SETUP softkey. The following message is displayed.

```
Input setup memory number to be deleted? ENTER to cancel.
```

Type the setup memory number to delete, then press the **Enter** key.

For example, if you type 12, setup memory 12 is deleted, setup memories 13 to 24 are shifted down by one, and setup memory 24 is set to "Open All".

If you press **Enter** key without typing a number, operation is canceled.

To insert a setup memory

Select the INSERT SETUP softkey. The following message is displayed.

```
Input setup memory number to be inserted? ENTER to cancel.
```

Type the setup memory number where you want to insert a new setup memory, then press the **Enter** key.

For example, if you specify 12, setup memory 24 is deleted, setup memories 12 to 23 are shifted up by one, and new setup memory 12 is set to "Open All".

If you press **Enter** key without typing a number, operation is canceled.

To clear setup memory

To clear a setup memory, select the CLEAR SETUP softkey. The following message is displayed:

```
Input setup memory number to be cleared? ENTER to cancel.
```

Type the setup memory number to clear, then press the **Enter** key. The setup memory is set to "Open All".

To clear all setup memories, select the CLEAR ALL softkey. The following message and softkeys are displayed:

```
Clear all setup memory. OK?
```

Softkey	Description
CLEAR ALL	Clears all setup memories.
CANCEL	Cancels the clear operation.

Select the CLEAR ALL softkey to clear all setup memories.

To modify the settings in Current Setup Memory

Select MODIFY SETUP softkey. MEMORY SETUP PANEL appears as shown in examples in Figure 5-12 to Figure 5-14, and softkeys shown after Figure 5-14 appear.

One setup memory is used for connection data of all installed cards. For Auto Config mode, settings for all cards are on one MEMORY SETUP PANEL. For Normal Config mode, each card uses a different MEMORY SETUP PANEL.

Figure 5-12

Memory Setup Panel for the E5252A in Auto Config.

```
Agilent E5250A Virtual Front Panel Utility

** MEMORY SETUP PANEL **
Current Setup Memory : 1
Comment              : MOSFET Vth
Card Number          : 0

                               1111111111222222222233333333334444444444
Input  1234567890123456789012345678901234567890123456789012345678
IV1    @.....
IV2    .@.....
IV3    ..@.....
IV4    ...@.....
IV5    .....
IV6    .....
HF1    .....
HF2    .....
CV1    .....
CV2    .....
```

Use softkeys to move cursor and to change status.

Figure 5-13 **Memory Setup Panel for the E5255A in Normal Config. (2 X 24 multiplexer)**

```
Agilent E5250A Virtual Front Panel Utility

** MEMORY SETUP PANEL **
Current Setup Memory : 1
Comment              : MOS CAP
Card Number          : 1

Input  12345678
IV1    @.....
BS1    * .@@@@@@@
IV1    .....
BS1    * @@@@@@@@
IV1    .....
BS1    * -----
```

Use softkeys to move cursor and to change status.

Figure 5-14 **Memory Setup Panel for the E5255A in Auto Config. (2 X 24 multiplexer)**

```
Agilent E5250A Virtual Front Panel Utility

** MEMORY SETUP PANEL **
Current Setup Memory : 1
Comment              : MOS CAP
Card Number          : 0

Input  123456789012345678901234
IV1    @.....
BS1    * .@@@@@@@@@@@@@@@@@-----
```

Use softkeys to move cursor and to change status.

Controlling the E5250A

Using Virtual Front Panel Utility

You can define labels to use for the input ports of each row in the MEMORY SETUP PANEL. Refer to “Defining Labels for the E5250A Input Ports” on page 5-31.

The following softkeys are displayed for MEMORY SETUP PANEL:

Softkey	Description
CHANGE CHAN	For changing the settings in the <i>Current Setup Memory</i> . See later. Displays cursor for input-output crosspoints and some softkeys.
COMMENT	For entering a comment for the setup memory. See next page.
NEXT CARD	(Displayed only for NORMAL Config mode, not AUTO Config mode.) Displays MEMORY SETUP PANEL of next card for changing settings.
SWITCH PAGE	(Displayed only for AUTO Config mode, not NORMAL Config mode.) Displays other page of MEMORY SETUP PANEL if more than 48 output ports. This softkey is displayed if the E5250A is configured for multiplexer that has more than 48 outputs (example, 2×96 multiplexer). This softkey toggles between the MEMORY SETUP PANEL for outputs 1 to 48, and for 49 to 96.
NEXT SETUP	Changes the Current Setup Memory to next setup memory number. Increases the <i>Current Setup Memory</i> number by 1. And changes the E5250A to the new settings.
PREV SETUP	Changes the Current Setup Memory to previous setup memory number. Decreases the <i>Current Setup Memory</i> number by 1. And changes the E5250A to the new settings.
GOTO SETUP	For changing the E5250A to settings of specified setup memory. See later. Changes <i>Current Setup Memory</i> to specified setup memory number.
SETUP MEMORY	Returns to the SETUP MEMORY MENU.

To enter a comment for the setup memory

Select the COMMENT softkey. The following message is displayed:

```
Input comment for this setup memory. (Max 20 char)
```

Type desired comment (maximum 20 characters), then press the **Enter** key. If you press **Enter** key without typing a comment, comment line is cleared.

To change the E5250A setup to specified setup memory

Select the GOTO SETUP softkey. The following message is displayed:

```
Input setup memory number to be connected?
```

Type the desired setup memory number, then press the **Enter** key. *Current Setup Memory* changes to the specified setup memory, and the E5250A changes to the new settings.

To cancel this operation, press the **Enter** key without typing a number.

To change the settings in a setup memory

Select the CHANGE CHAN softkey. A cursor for selecting input-output crosspoints is displayed. And the following softkeys are displayed for changing the settings of the setup memory.

Change the setting of the setup memory by using these softkeys.

NOTE

Invalid Input Port

The following E5250A input port *combinations* cannot be used for making a setup memory.

- IV5 (INPUT 5) and HF1 (INPUT 7) and CV1 (INPUT 9)
- IV6 (INPUT 6) and HF2 (INPUT 8) and CV2 (INPUT 10)

For example, when IV5 is used, HF1 and CV1 cannot be used.

Controlling the E5250A
Using Virtual Front Panel Utility

Softkey Menu 1:

Softkey	Description
OPEN/ CLOSE	<p>Changes the relay state (open or close) of crosspoint selected by the cursor. The softkey toggles the state between open and close. The E5250A settings are changed in real time.</p> <p>If bias mode is ON and cursor is in the row of input bias port, this softkey changes the relay state; open, close, and bias disabled.</p> <p>. means open. @ means close. – means bias disabled.</p> <p>When bias mode is ON, if you disconnect a bias enabled output port from a non-bias input port, the output port is automatically connected to the input bias port.</p>
UP	Moves the cursor upward.
LEFT	Moves the cursor to the left.
RIGHT	Moves the cursor to the right.
DOWN	Moves the cursor downward.
MORE	Displays more softkeys. The displayed softkeys depend on whether cursor selects input Bias Port and Bias Mode is ON. See Softkey Menu 2 and Menu 3 on next pages.
RETURN	Displays the previous level of the softkey menu, shown previously in "To Modify the Settings in Current Setup Memory".

NOTE

Moving the Cursor

Move the cursor by using the UP, DOWN, RIGHT, LEFT softkeys. Do not use arrow keys on the 4155/4156 front panel.

Softkey Menu 2:

For the following conditions, the following softkeys are displayed by selecting the MORE softkey on Softkey Menu 1.

Cursor points to row of normal input port or to row of input Bias Port with Bias Mode OFF.

Softkey	Description
OPEN ALL	Opens all relays. If Bias Mode is ON, then closes relays to connect bias enabled output ports to the input Bias Port.
OPEN ROW	Opens all relays of row at cursor. If Bias Mode is ON, then closes relays to connect bias enabled output ports (that are not connected to other input ports) to the input Bias Port.
CLOSE ROW	Closes all relays of row at cursor. And all output ports are disconnected from the input Bias Port.
MORE	Displays softkey menu 1.
RETURN	Displays the previous level of softkey menu.

Softkey Menu 3:

For the following conditions, the following softkeys are displayed by selecting the MORE softkey on Softkey Menu 1:

Cursor points to row of input Bias Port and Bias Mode is ON.

Softkey	Description
OPEN ALL	Opens all relays, then connects all bias enabled output ports to the input Bias Port.
DISABLE ROW	Bias disables all output ports. So relays open to disconnect all output ports from the input Bias Port.
ENABLE ROW	Bias enables all output ports, then connects all output ports (that are not connected to another input port) to the input Bias Port.
MORE	Displays softkey menu 1.
RETURN	Displays the previous level of softkey menu.

Saving/Loading the Setup Data

Select the SAVE/LOAD softkey. The following softkeys are displayed:

Softkey	Description
CATALOG	Lists the files of diskette that is in the 4155/4156 internal disk drive.
SAVE FILE	For saving setup data to the diskette that is in the 4155/4156 internal disk drive. See below.
LOAD FILE	For loading setup data from the diskette that is in the 4155/4156 internal disk drive. See below.
RETURN	Returns to the VFP main menu.

To save setup data to diskette

Select the SAVE FILE softkey. The following message is displayed:

Input Save file name

Type the name (maximum 8 characters) of file to which you want to save the setup data, then press the **Enter** key.

To cancel this operation, press the **Enter** key without typing the file name.

To load setup data from diskette

Select the LOAD FILE softkey. The following message is displayed:

Input Load file name

Type the file name of setup data you want to load, then press the **Enter** key. The VFP setup data is loaded into the VFP.

To cancel this operation, press the **Enter** key without typing the file name.

After loading the file, the E5250A changes to the setting of setup memory 1.

6**Programming the E5250A**

Programming the E5250A

Standard Commands for Programmable Instruments (SCPI) is a universal programming language for electronic test and measurement instruments, and based on IEEE 488.1 and IEEE488.2.

This chapter describes how to create programs that contain SCPI commands to control the E5250A. These programs can be run from an external controller.

This chapter explains the following programming tasks along with programming examples:

- “SCPI Programming Basics” explains the basics of using a program that contains SCPI commands to control the E5250A and runs on HP BASIC.
- “Creating a Control Program” shows typical programming flow for controlling the E5250A.
- “Programming Examples” provides some examples of the E5250A programming.
- “Using the VFP Data Upload Library” explains how to use the VFP Data Upload Library furnished with the E5250A.
- “Using the Capacitance Compensation Routine” explains how to use the Capacitance Compensation Routine furnished with the E5250A.

For the details about SCPI commands, refer to Chapter 7.

In addition to this chapter, refer to Chapter 9, which describes how to use and modify the sample programs furnished with the E5250A, and helps to increase your understanding about programming.

CAUTION

The VFP Data Upload Library and the Capacitance Compensation Routine can be used only in a program runs on HP BASIC.

SCPI Programming Basics

This section describes the structure of SCPI commands, and the basics of using an program that contains SCPI commands to control the E5250A and runs on HP BASIC:

- “SCPI Command Hierarchy”
- “Controlling E5250A by Using HP BASIC”

SCPI Command Hierarchy

The SCPI commands use a hierarchical structure for subsystem commands similar to a file system. For example, in `:ROUT:CONN:RULE` command, the hierarchy is as follows:

ROUT	root
CONN	sub-level 1
RULE	sub-level 2

The colon at the beginning of the command means root.

The colons between two command keywords means moving down to a lower level.

NOTE

Using a Semicolon to Reduce Typing

A semicolon enables two commands to be sent on the same line.

For example, `:ROUT:CONN:RULE ALL, FREE; SEQ ALL, BBM` is the same as the following two commands:

```
:ROUT:CONN:RULE ALL, FREE
```

```
:ROUT:CONN:SEQ ALL, BBM
```

So, using a semicolon reduces typing and simplifies the program.

A command terminator (such as carriage return) resets the path to root.

Controlling E5250A by Using HP BASIC

1. Assign I/O path for controlling the E5250A by using the ASSIGN command.

In the following example, the select code of the external computer is 7 and GPIB address of the E5250A is 22.

```
10 ASSIGN @Hp5250 TO 722
```

2. Use OUTPUT command to send SCPI commands to control the E5250A.

3. Use ENTER command to get query response from the E5250A.

Example:

```
10 REAL Complete
20 !
30 ASSIGN @Hp5250 TO 722
40 !
50 OUTPUT @Hp5250;"*RST"
60 !
70 OUTPUT @Hp5250;":ROUT:FUNC NCON"
80 OUTPUT @Hp5250;":ROUT:CONN:RULE ALL,FREE"
90 OUTPUT @Hp5250;":ROUT:CONN:SEQ ALL,BBM"
100 OUTPUT @Hp5250;":ROUT:CLOS (@10101,10202)"
110 !
120 OUTPUT @Hp5250;"*OPC?"
130 ENTER @Hp5250;Complete
140 !
150 END
```

Line Number	Description
10	Declares "Complete" as a real number.
30	Assigns I/O path to control the E5250A.
50	Resets the E5250A.
70	Sets the E5250A to Normal channel configuration mode.
80	Sets all cards to free connection rule.
90	Sets all cards to break-before-make connection sequence.
100	Creates channels 10101 and 10202.
120 and 130	Waits until all operations are complete.

Creating a Control Program

This section explains how to create a control program for the E5250A.

The control program basically consists of the following six parts:

- “Defining Channel Configuration Mode”
- “Defining Connection Rule”
- “Defining Connection Sequence”
- “Using Bias Mode”
- “Using Couple Port (for E5252A only)”
- “Controlling Relay Switching”

Table 6-1 summarizes the commands for each part of the control program for the E5250A. In the table, default setting means the instrument state by the *RST command or power on.

CAUTION

The SCPI commands introduced in this section are ROUTe subsystem commands for controlling the E5250A.

There are also other SCPI subsystem commands for the E5250A: DIAGnostic and SYSTem subsystem commands. For details about all SCPI commands, refer to Chapter 7.

Table 6-1 Programming Summary

	Description	Command	Default Setting
1	Defines Channel Configuration Mode	:ROUT:FUNC <i>channel_config</i>	NCON
2	Defines Connection Rule	:ROUT:CONN:RULE <i>card_no, rule</i>	ALL,FREE
3	Defines Connection Sequence	:ROUT:CONN:SEQ <i>card_no, sequence</i>	ALL,BBM
4	Using Bias Mode		
	Selects input Bias Port (for E5252A)	:ROUT:BIAS:PORT <i>card_no, input_port_no</i>	ALL,10
	Bias enables all output ports	:ROUT:BIAS:CHAN:ENAB:CARD <i>card_no</i>	ALL
	Bias enables specified output ports	:ROUT:BIAS:CHAN:ENAB:LIST <i>channel_list</i>	All enabled
	Bias disables all output ports	:ROUT:BIAS:CHAN:DISA:CARD <i>card_no</i>	All enabled
	Bias disables specified output ports	:ROUT:BIAS:CHAN:DISA:LIST <i>channel_list</i>	All enabled
	Sets Bias Mode ON/OFF	:ROUT:BIAS:STAT <i>card_no, state</i>	ALL,OFF
5	Using Couple Port (for E5252A)		
	Sets up Couple Port	:ROUT:COUP:PORT <i>card_no, 'input_port_no'</i>	No couple ports
	Sets Couple Port Mode ON/OFF	:ROUT:COUP:STAT <i>card_no, state</i>	ALL,OFF
6	Controls Relays on Cards		
		:ROUT:CLOS <i>channel_list</i>	All relays open
		:ROUT:OPEN <i>channel_list</i>	All relays open
		:ROUT:OPEN:CARD <i>card_no</i>	ALL

Parameter	Description
<i>channel_config</i>	NCON or ACON.
<i>rule</i>	FREE or SROU.
<i>sequence</i>	NSEQ, BBM or MBBR.
<i>state</i>	ON (1) or OFF (0).
<i>channel_list</i>	5 digit decimal number. See Chapter 5.
<i>card_no</i>	ALL or 0 or 1 to 4 are available.
<i>input_port_no</i>	1 to 10 are available for :ROUT:BIAS:PORT. 1, 3, 5, 7 or 9 are available for :ROUT:COUP:PORT.

For details about these parameters, refer to Chapter 5 and Chapter 7.

CAUTION

Bias Port and Couple Port cannot be set for the same input port number.

Defining Channel Configuration Mode

Following commands are used to set the Channel Configuration mode. For details, refer to “Channel List and Channel Configuration” on page 5-6.

Command	Description
:ROUT:FUNC NCON	Sets Normal Channel Configuration mode.
:ROUT:FUNC ACON	Sets Auto Channel Configuration mode.

Example:

```
100 OUTPUT @Hp5250;":ROUT:FUNC NCON"  
110 ! Sets E5250A to Normal channel configuration mode.
```

Defining Connection Rule

Following commands are used to set the Connection Rule. For details, refer to “Connection Rule” on page 5-9.

Command	Description
:ROUT:CONN:RULE <i>card_no</i> ,FREE	Sets Free Connection rule.
:ROUT:CONN:RULE <i>card_no</i> ,SROU	Sets Single Connection rule.

Example:

```
100 OUTPUT @Hp5250;":ROUT:CONN:RULE ALL,FREE"  
110 ! Sets all cards to Free Connection rule.
```

Defining Connection Sequence

Following commands are used to specify the Connection Sequence. For details, refer to “Connection Sequence” on page 5-10.

Command	Description
:ROUT:CONN:SEQ <i>card_no</i> ,NSEQ	Connection sequence not specified.
:ROUT:CONN:SEQ <i>card_no</i> ,BBM	Specifies Break-before-Make connection sequence.
:ROUT:CONN:SEQ <i>card_no</i> ,MBBR	Specifies Make-before-Break connection sequence.

Example:

```
100 OUTPUT @Hp5250;":ROUT:CONN:SEQ ALL,BBM"  
110 ! Sets all cards to Break-before-Make connection  
sequence.
```

Using Bias Mode

If you use the Bias Mode, following commands are available. For details, refer to “Bias Mode” on page 5-11.

- Selects input port to be input Bias Port on specified card (for E5252A only).

Command	Description
:ROUT:BIAS:PORT <i>card_no,input_port_no</i>	<i>input_port_no</i> specifies which input port (on specified card) to be the input Bias Port.

- Bias enables the output ports.

Command	Description
:ROUT:BIAS:CHAN:ENAB:CARD <i>card_no</i>	Bias enables all output ports on specified card.
:ROUT:BIAS:CHAN:ENAB:LIST <i>channel_list</i>	Bias enables the specified output ports.

- Bias disables the output ports.

Command	Description
:ROUT:BIAS:CHAN:DISA:CARD <i>card_no</i>	Bias disables all output ports on specified card.
:ROUT:BIAS:CHAN:DISA:LIST <i>channel_list</i>	Bias disables the specified output ports.

- Turns the Bias Mode ON/OFF

Command	Description
:ROUT:BIAS:STAT <i>card_no,ON</i>	Turns on Bias Mode for card specified by <i>card_no</i> .
:ROUT:BIAS:STAT <i>card_no,OFF</i>	Turns off Bias Mode for card specified by <i>card_no</i> .

Example:

```
100 OUTPUT @Hp5250;":ROUT:BIAS:PORT ALL,1"
110 ! Selects SMU1 input port to be input Bias Port for all
cards.
120 OUTPUT @Hp5250;":ROUT:BIAS:CHAN:ENAB:CARD ALL"
130 ! Bias enables all output ports on all cards.
140 OUTPUT @Hp5250;":ROUT:BIAS:STAT ALL,ON"
150 ! Turns on the Bias Mode for all cards.
```

Using Couple Port (for E5252A only)

If you use Couple Port, the following commands are available. For details, refer to “Couple Port” on page 5-13.

- Sets up the couple ports for specified card. You can specify multiple *input_port_no* to set up multiple couple ports.

Command	Description
:ROUT:COUP:PORT <i>card_no</i> , <i>input_port_no</i> '	Sets up couples ports determined by <i>input_port_no</i> on card specified by <i>card_no</i> .

- Turns the Couple Port Mode ON or OFF

Command	Description
:ROUT:COUP:STAT <i>card_no</i> ,ON	Turns on the couple port mode for card specified by <i>card_no</i> .
:ROUT:COUP:STAT <i>card_no</i> ,OFF	Turns off the couple port mode for card specified by <i>card_no</i> .

Example:

```
100 OUTPUT @Hp5250;":ROUT:COUP:PORT ALL,'1,3'"
110 ! Sets up two couple ports (1&2 and 3&4) on all cards.
120 OUTPUT @Hp5250;":ROUT:COUP:STAT ALL,ON"
130 ! Turns on the couple port mode for all cards.
```

Controlling Relay Switching

Following commands are used to control relay switching. For details of *channel_list*, see “Channel List and Channel Configuration” on page 5-6.

Command	Description
:ROUT:CLOS <i>channel_list</i>	Close the relays specified by <i>channel_list</i> .
:ROUT:OPEN <i>channel_list</i>	Open the relays specified by <i>channel_list</i> .
:ROUT:OPEN:CARD <i>card_no</i>	Open all relays on card specified by <i>card_no</i> .

Example:

```
100 OUTPUT @Hp5250;":ROUT:CLOS (@10101,10202)"  
110 ! Closes relays to create channels 10101 and 10202.
```

Programming Examples

This section provides examples of control programs for the E5250A.

The programs are written in the HP BASIC language, and can be executed without any modifications. But the program examples do not include instrument control routines, so to make a measurement, you need to add the desired routines.

This section explains the following three examples:

- “Channel Creation Example”
- “Bias Mode Example”
- “Couple Port Example”

For each example, the required conditions, program list, and program description are given.

Channel Creation Example

The following example is a typical control program for the E5250A with the E5252A, which connects instrument output to DUT as shown in Figure 6-1. Bias Mode and Couple Port are not used in this example.

Figure 6-1

MOSFET Connection Example

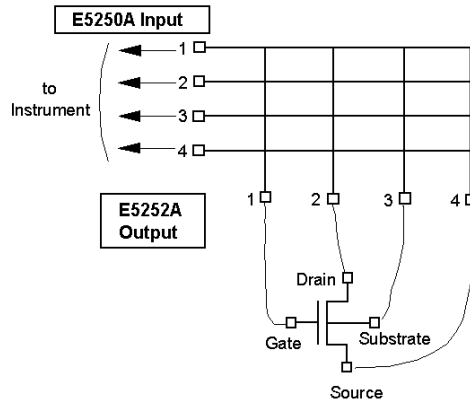

Required Conditions:

This program assumes the following conditions.

E5250A Installed Cards:

- Slot 1: E5252A
- Slot 2 to 4: not used.

E5250A Input Ports:

- SMU INPUT 1 to 4: should be connected to instrument.
- SMU INPUT 5 to 6: not used.
- AUX INPUTs: not used.

E5252A Output Ports:

Output 1 to 4 are used in the program, and should be connected as follows.

- Output 1: Gate
- Output 2: Drain
- Output 3: Substrate
- Output 4: Source

Program List:

```

10 ! Example: Creating Connection Channels
20 !
30 INTEGER Complete
40 DIM Channel$(100)
50 ! (Gate, Drain, Substrate, Source)
60 Channel$="(10101,10202,10303,10404)" ! Channels to Create
70 !
80 ! Put Instrument Initialization Routine here
90 !
100 ASSIGN @Hp5250 TO 722 ! Assigns E5250A GPIB address to 722
110 OUTPUT @Hp5250;"*RST"
120 OUTPUT @Hp5250;":ROUT:FUNC NCON" ! Sets Normal Config mode
130 OUTPUT @Hp5250;":ROUT:CONN:RULE ALL,SROU"! Sets Single rule
140 OUTPUT @Hp5250;":ROUT:CONN:SEQ ALL,BBM" ! Sets BBM sequence
150 !
160 OUTPUT @Hp5250;":ROUT:CLOS "&Channel$ ! Creates channels
170 OUTPUT @Hp5250;"*OPC?"
180 ENTER @Hp5250;Complete
190 !
200 ! Put Measurement Routine here
210 !
220 OUTPUT @Hp5250;":ROUT:OPEN:CARD ALL" ! Opens all relays
230 OUTPUT @Hp5250;"*OPC?"
240 ENTER @Hp5250;Complete
250 !
260 OUTPUT @Hp5250;"*RST"
270 !
280 END

```

Line Number	Description
40	Declares data size of Channel\$, which is used as <i>channel_list</i> parameter.
60	Defines the desired <i>channel_list</i> .
80	Here, insert the initialization routine for your measurement instrument.
110	Resets the E5250A.
120	Sets the E5250A to Normal channel configuration mode.
130	Sets the connection rule to Single.
140	Sets the connection sequence to Break-Before-Make.
160	Closes relays to create the channels specified by <i>Channel\$</i> .
170 to 180	Waits until the relay closing operation is completed.
200	Here, insert measurement routine for your measurement instrument.
220 to 240	Opens all relays, and waits until open operation is completed.
260	Resets the E5250A.

Bias Mode Example

The following example shows how to use Bias Mode for the E5255A.

Figure 6-2

Example of Bias Mode

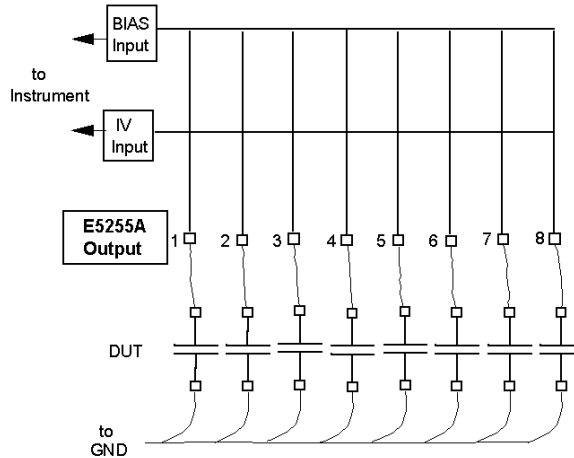

Required Conditions:

This program assumes the following conditions.

E5250A Installed Cards:

- Slot 1: E5255A
- Slot 2 to 4: not used.

E5250A Input Ports:

- SMU INPUT 1: should be connected to instrument.
- SMU INPUT 2 to 6: not used.
- AUX INPUTs: not used.

E5255A Connection:

- IV Input Connection: IVin1 should be connected to the E5250A SMU INPUT 1.
- Bias Input Connection: BIAS INPUT 51 should be connected to bias source.

E5255A Output Ports:

- Block 1: outputs 1 to 8 are used in the program.
- Block 2 and 3: not used.

Program List:

```

10 ! Example: Using Bias Mode
20 !
30 INTEGER Complete
40 DIM Channel$(100)
50 Channel$="(010101:10108)"
60 !
70 ! Put Instrument Initialization Routine here.
80 !
90 ASSIGN @Hp5250 TO 722
100 OUTPUT @Hp5250;"*RST"
110 OUTPUT @Hp5250;":ROUT:FUNC NCON"
120 OUTPUT @Hp5250;":ROUT:CONN:RULE ALL,FREE"
130 !OUTPUT @Hp5250;":ROUT:BIAS:PORT 1,7"
140 OUTPUT @Hp5250;":ROUT:BIAS:CHAN:ENAB:CARD 1"
150 OUTPUT @Hp5250;":ROUT:BIAS:STAT 1,ON"

```

Line Number	Description
40	Declares data size of Channel\$, which is used as <i>channel_list</i> parameter.
50	Defines the desired <i>channel_list</i> .
70	Here, insert the initialization routine for your measurement instrument.
100	Resets the E5250A.
110	Sets the E5250A to Normal channel configuration mode.
120	Sets the connection rule to FREE.
130	This line is not used (commented) for the E5255A. If you use the E5252A instead of the E5255A, use this line, which defines AUX INPUT HF1 to be the input Bias Port.
140	Bias enables all output ports of card 1 for the Bias Mode.
150	Turns on the Bias Mode. All output ports of card 1 are connected to the input Bias Port.

Programming the E5250A

Programming Examples

```
160 !
170 ! Put Bias Source Control Routine here.
180 !
190 OUTPUT @Hp5250;":ROUT:CLOS "&Channel$
200 OUTPUT @Hp5250;"*OPC?"
210 ENTER @Hp5250;Complete
220 !
230 ! Put Measurement Routine here
240 !
250 OUTPUT @Hp5250;":ROUT:BIAS:STAT ALL,OFF"
260 OUTPUT @Hp5250;":ROUT:OPEN:CARD ALL"
270 OUTPUT @Hp5250;"*OPC?"
280 ENTER @Hp5250;Complete
290 !
300 OUTPUT @Hp5250;"*RST"
310 !
320 END
```

Line Number	Description
170	Here, insert your bias source control routine.
190	Disconnects all output ports of block 1 from the input Bias Port, then connects the output ports to the IV input port.
200 to 210	Waits until the channel connections are completed.
230	Here, insert measurement routine for your measurement instrument.
250	Turns off the Bias Mode.
260 to 280	Opens all relays, then connects all output ports of block 1 to the input Bias Port again, and waits until the connections are completed.
300	Resets the E5250A.

Couple Port Example

The following example shows how to use the Couple Port. This function is available only for the E5252A.

Figure 6-3

Example of Couple Port

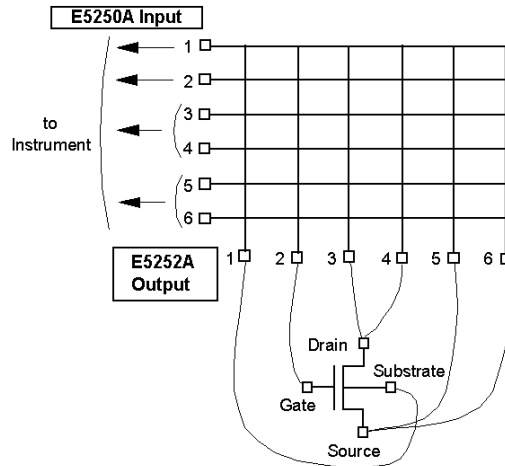

Required Conditions:

This program assumes the following conditions.

E5250A Installed Cards:

- Slot 1: E5252A must be installed.
- Slot 2 to 4: not used.

E5250A Input Ports:

- SMU INPUT 1 and 2: should be connected to instrument.
- SMU INPUT 3 & 4 and 5&6: should be connected to instrument. Couple port.
- AUX INPUTs: not used.

The program couples SMU INPUT 3&4 and couples SMU INPUT 5&6. For each Couple Port, use Kelvin triaxial cable for instrument connection.

E5252A Output Ports:

Output 1, 2, 3, 4, 5, 6 should be connected to :
Substrate, Gate, Drain, Drain, Source, Source, respectively.

Programming the E5250A

Programming Examples

Program List:

```
10 ! Example: Using Couple Port
20 !
30 INTEGER Complete
40 DIM Channel$(100)
50 ! (Substrate,Gate,Drain,Source)
60 Channel$="(0101,202,303,505)"
70 !
80 ! Put Instrument Initialize Routine here
90 !
100 ASSIGN @Hp5250 TO 722
110 OUTPUT @Hp5250;"*RST"
120 OUTPUT @Hp5250;":ROUT:FUNC ACON"
130 OUTPUT @Hp5250;":ROUT:CONN:RULE ALL,SROU"
140 OUTPUT @Hp5250;":ROUT:CONN:SEQ ALL,BBM"
```

Line Number	Description
40	Declares data size of Channel\$, which is used as <i>channel_list</i> parameter.
60	Defines the desired <i>channel_list</i> .
80	Here, insert the initialization routine for your measurement instrument.
110	Resets the E5250A.
120	Sets the E5250A to Auto channel configuration mode.
130	Sets the connection rule to Single.
140	Sets the connection sequence to Break-Before-Make.

```

150 OUTPUT @Hp5250;":ROUT:COUP:PORT ALL,'3,5'"
160 OUTPUT @Hp5250;":ROUT:COUP:STAT ALL,ON"
170 !
180 OUTPUT @Hp5250;":ROUT:CLOS "&Channel$
190 OUTPUT @Hp5250;"*OPC?"
200 ENTER @Hp5250;Complete
210 !
220 ! Put Measurement Routine here
230 !
240 OUTPUT @Hp5250;":ROUT:OPEN:CARD ALL"
250 OUTPUT @Hp5250;"*OPC?"
260 ENTER @Hp5250;Complete
270 !
280 OUTPUT @Hp5250;"*RST"
290 !
300 END

```

Line Number	Description
150	Sets up SMU3&4 and SMU5&6 input ports as Couple Ports.
160	Turns on the Couple Port mode.
180	Closes relays to create channels specified by <i>Channel\$</i> .
190 to 200	Waits until the relay close operation is completed.
220	Here, insert measurement routine for your measurement instrument.
240 to 260	Opens all relays, and waits until open operation is completed.
280	Resets the E5250A.

Using the VFP Data Upload Library

This section introduces and explains how to use the VFP Data Upload Library:

- “VFP Data Upload Library”
- “Programming Example”
- “Before Executing Your Program”
- “Error Messages”

For information about using the VFP, refer to “Using Virtual Front Panel Utility” on page 5-25.

CAUTION

The VFP Data Upload Library can be used only in a program that runs on HP BASIC.

VFP Data Upload Library

VFP Data Upload Library is a subprogram library used for loading data (that was made and saved by the Virtual Front Panel utility) to your program. The library contains the following four subprograms. The library runs on HP BASIC.

Load_vfp_data subprogram

Loads data file (that was created and saved by Virtual Front Panel utility) to your program. The file contains all data from the 24 Setup Memories, and setup mode data for initializing the E5250A.

Syntax: `Load_vfp_data (Address_5250, "LOAD_FILE", Setup_data$)`

Parameters:

- Address_5250:** GPIB address of the E5250A.
- LOAD_FILE:** File name of data you want to load.
- Setup_data\$:** Data string for internal use in the library. Must declare 14000 byte data size.

Example: `CALL Load_vfp_data (722, "MAT48_1", Mat48_data$)`

Init_vfp_setup subprogram

Initializes the E5250A based on the setup mode data loaded by the Load_vfp_data subprogram. This subprogram sets the following parameters:

- Configuration Mode: Auto or Normal
- Connection Rule: Free
- Connection Sequence: Break Before Make
- Bias State: Bias Mode (ON/OFF) for each card.
- Input Bias Port for each card.

This subprogram must be entered before the Connect_vfp subprogram.

Syntax: `Init_vfp_setup (Setup_data$)`

Parameter:

- Setup_data\$:** Data string for internal use in the library. Must declare 14000 byte data size.

Example: `CALL Init_vfp_setup (Mat48_data$)`

Connect_vfp subprogram

Makes relay connections based on data from the specified Setup Memory. Data from all 24 Setup Memories was loaded by the Load_vfp_data subprogram.

Syntax: `Connect_vfp (Setup_data$, Setup_num)`

Parameters: *Setup_data\$:* Data string for internal use in the library. Must declare 14000 byte data size.

Setup_num: Setup Memory number: 1 to 24.

Example: `CALL Connect_vfp (Mat48_data$, 1)`

FNGet_vfp_comment\$ subprogram

Returns comment from the specified Setup Memory. Comments for all 24 Setup Memories were loaded by the Load_vfp_data subprogram.

Syntax: `FNGet_vfp_comment$ (Setup_data$, Setup_num)`

Parameters: *Setup_data\$:* Data string for internal use in the library. Must declare 14000 byte data size.

Setup_num: Setup Memory number from which to get comment: 1 to 24.

Example: `Comment$=FNGet_vfp_comment$ (Mat48_data$, 1)
DISP "Comment="; Comment$`

Programming Example

The following program is an example for using the VFP Data Upload Library.

```

10 ! Example for using VFP Data Upload Library
20 !
30 COM /Vfp_com_data/ Mat48_data$[14000]
40 DIM Comment$[20]
50 Address_5250=722 ! E5250A GPIB Address: 722
60 Setup_num=1      ! VFP Setup Memory Number: 1
70 !
80 OUTPUT Address_5250;"*RST"
90 !
100 CALL Load_vfp_data(Address_5250,"MAT48",Mat48_data$)
110 CALL Init_vfp_setup(Mat48_data$)
120 !
130 DISP "SETUP IN PROGRESS. SETUP NO.=";Setup_num
140 CALL Connect_vfp(Mat48_data$,Setup_num)
150 !
160 Comment$=FNGet_vfp_comment$(Mat48_data$,Setup_num)
170 !
180 DISP "SETUP WAS COMPLETED. SETUP COMMENT:",Comment$
190 !
200 END

```

Line Number	Description
30	Declares data size of Mat48_data\$, which is for internal use by the library. Size must be 14000.
40	Declares data size of Comment\$, which is for storing comment from Setup Memory.
100	Loads the data file MAT48, which was made by VFP utility.
110	Initializes the E5250A based on the loaded data.
140	Connects relays based on data from specified Setup Memory.
160 to 180	Gets the comment from specified Setup Memory, and displays the comment.

Before Executing Your Program

Before executing a program that uses subprograms from the VFP Data Upload Library, do the following:

1. Link the library to your program:

Link the library as shown in the following example. The VFP Data Upload Library is an ASCII file on the E5250A Program Disk.

- a. GET the file UPLOAD from the E5250A Program Disk.

```
GET "UPLOAD"
```

- b. RE-STORE the file.

```
RE-STORE "U_LIB"
```

- c. LOAD your program.

- d. Link the library to your program by using the LOADSUB statement:

```
LOADSUB ALL FROM "U_LIB"
```

2. Change the mass storage device

Before executing your program, you must set the mass storage device to the device that has the file that will be loaded by Load_vfp_data subprogram.

For example, if the file is on the device ":CS80,701,1", you should change the mass storage device by using the MSI statement:

```
MSI ":CS80,701,1"
```

Or you can specify the mass storage device as follows:

```
Load_vfp_data(Address_5250,"LOAD_FILE:CS80,701,1",Setup_data$)
```

Error Messages

If any error related to the VFP Data Upload Library occurs in your program, one of following error messages is displayed, and the program is paused.

- `Cannot configure for AUTO. Normal mode used.`
Cannot use the data for Auto Config mode.
Normal Configuration mode is used.
- `File name is wrong.`
File name is not correct.
Enter the correct file name.
- `Instrument at address XXX is not E5250A!`
Instrument specified by GPIB address *XXX* is not E5250A.
Confirm GPIB address for the E5250A, and enter the correct value.

Note: *XXX* is the number you specified for the parameter *Address_5250* in the *Load_vfp_data* subprogram.
- `File data is not VFP format, or is broken.`
Cannot load the data because the data format is not for VFP or the data is broken. Enter the correct file name.
- `GPIB address, connection or firmware is bad.`
Timeout occurred for connecting the E5250A.
Confirm the GPIB address of the E5250A, and the connection of the GPIB cable. Or the E5250A firmware may be defective.
- `Must execute Init_vfp_setup before Connect_vfp.`
Init_vfp_setup must be called before calling Connect_vfp.

Using the Capacitance Compensation Routine

This section introduces and explains how to use the Capacitance Compensation Routine.

- “Capacitance Compensation Routine”
- “Required Conditions”
- “Programming Example”
- “Before Executing Your Program”
- “Error Messages”

NOTE

Restrictions for Using the Routine

Capacitance Compensation Routine can be used only in an program runs on HP BASIC. Corrected data by the routine is not guaranteed. But typical data (supplemental data) is as follows:

Capacitance measurement accuracy: $\pm 1\% \pm 0.5\text{ pF}$

This typical data is for the following measurement conditions:

Frequency: 1 kHz to 1 MHz

Measurement Range: Maximum 1000 pF

Measurement Terminal: At the end of the Agilent 16494A-001 (1.5 m triaxial cable) connected to the E5252A output terminal.

The typical data does not apply to cable or anything extended from the 16494A triaxial cable. Also the conditions specified in “Required Conditions” on page 6-30 must be satisfied.

Capacitance Compensation Routine

This routine is an subprogram used to compensate for capacitance measurement error caused by the E5250A with the E5252A matrix card installed. The subprogram is used with Agilent 4284A Precision LCR Meter. You enter capacitance and conductance data measured by the 4284A as a parameter, and this subprogram returns the compensated value. This routine runs on HP BASIC.

Syntax:

`Ccompen_5250 (Freq, L1, L2_h, L2_l, L3_h, L3_l, C_m, G_m, C_c, G_c)`

Parameter:

- | | |
|-------------|---|
| <i>Freq</i> | Measurement Frequency (Hz): 1000 Hz to 1000000 Hz (1 kHz to 1 MHz). |
| <i>L1</i> | Length (in meters) of 16494A triaxial cable connected from E5252A output to connector plate. |
| <i>L2_h</i> | Length (in meters) of triaxial cable connected from connector plate to DUT (High terminal of capacitor).
If you do not use triaxial cable, enter 0 for this parameter. |
| <i>L2_l</i> | Length (in meters) of triaxial cable connected from connector plate to DUT (Low terminal of capacitor).
If you do not use triaxial cable, enter 0 for this parameter. |
| <i>L3_h</i> | Length (in meters) of coaxial cable connected from connector plate to DUT (High terminal of capacitor).
If you do not use coaxial cable, enter 0 for this parameter. |
| <i>L3_l</i> | Length (in meters) of coaxial cable connected from connector plate to DUT (Low terminal of capacitor).
If you do not use coaxial cable, enter 0 for this parameter. |
| <i>C_m</i> | Capacitance data (in F) measured by 4284A. |
| <i>G_m</i> | Conductance data (in S) measured by 4284A. |
| <i>C_c</i> | Compensated capacitance value (in F) returned by Capacitance Compensation Routine. |
| <i>G_c</i> | Compensated conductance value (in S) returned by Capacitance Compensation Routine. |

Required Conditions

This subprogram requires the following conditions:

- Setting of the 4284A:
 - Option Required:** 4284A-006
 - Frequency:** 1 kHz to 1 MHz.
 - Measurement Function:** Cp-G.
 - Connection to E5250A:** Use Agilent 16048D/E Test Cable and BNC T-type Adapter (Agilent part number: 1250-2405).
 - Calibration:** Must be done at the end of the 16048D/E.
- E5250A Input port:
CV1 and CV2.
- Connection of E5252A output:
 - To Connector Plate:** Use Agilent 16494A Triaxial Cable.
 - From Connector Plate to DUT:** Use low noise coaxial cable (Agilent part number: 8121-1191) for minimizing the compensation error.

You can also use another type of coaxial cable, triaxial cable, or combination of these. See “Using Other than Recommended Cable”.

Using Other than Recommended Cable

If you do not use the low noise coaxial cable (Agilent part number: 8121-1191) for the connection from Connector Plate to DUT, the Capacitance Compensation Routine cannot return accurate results. To get more accurate compensation results, do following:

1. Measure R, L, C of your cable using the 4284A. Measurement setup is as follows:

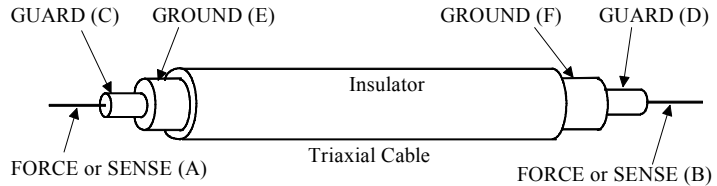

Measurement Parameter	Measurement Frequency	Measurement Function	Measurement Terminals ^a
R	1 kHz to 1 MHz ^b	–	A and B
L		SERIES	see note ^c
C		PARALLEL	A and C

- a. See figure above.
- b. Select 1 point in the frequency range.
- c. For triaxial cable, connect B to F directly, and measure L between A and E.
For coaxial cable, connect B to D directly, and measure L between A and C. Ignore E and F.

2. Overwrite the R, L, C data in the program lines listed below. The data must be in per meter values.

Program Line No.	Defines R, L, C value of
1420	Triaxial cable for C meter High terminal
1430	Triaxial cable for C meter Low terminal
1440	Coaxial cable for C meter High terminal
1450	Coaxial cable for C meter Low terminal

Original program defines initial data by DATA statement in the "Rlc_data" block as shown below:

```

1350 Rlc_data: !
1360 ! R [ohm]    L [H]    C [F]
      :          :          :
1420 DATA 100.70E-3, 400.00E-9, 80.00E-12 !User Triax Cbl H
1430 DATA 100.70E-3, 400.00E-9, 80.00E-12 !User Triax Cbl L
1440 DATA 114.00E-3, 544.00E-9, 130.00E-12 !User Coax Cbl H
1450 DATA 114.00E-3, 544.00E-9, 130.00E-12 !User Coax Cbl L
      :          :          :

```

Programming Example

The following program is an example for using the capacitance compensation subprogram:

```
100 ! Example of Capacitance Compensation
110 !
120 Freq=1.E+6 ! MEASUREMENT FREQUENCY: 1MHz
130 L1=1.5 ! E5252A OUTPUT CABLE: 1.5m
140 L2_h=0 ! TRIAX CABLE High SIDE: none (0m)
150 L2_l=0 ! TRIAX CABLE Low SIDE: none (0m)
160 L3_h=2 ! COAX CABLE High SIDE: 2m
170 L3_l=2 ! COAX CABLE Low SIDE: 2m
180 !
190 OUTPUT @Hp4284;"FUNC:IMP CPG" ! SET Cp-G FUNCTION
200 OUTPUT @Hp4284;"FREQ "&VAL$(Freq) ! SET MEAS FREQ
210 OUTPUT @Hp4284;"CORR:LENG 2M" ! SET 16048D LENGTH
220 OUTPUT @Hp4284;"*TRG"
230 ENTER @Hp4284;C_m,G_m,Stat
240 !
250 Ccompen 5250(Freq,L1,L2_h,L2_l,L3_h,L3_l,C_m,G_m,C_c,G_c)
260 DISP "CORRECTED C DATA=";C_c
270 DISP "CORRECTED G DATA=";G_c
280 !
290 END
```

Before Executing Your Program

Before executing a program that uses the capacitance compensation subprogram, you must link the subprogram to your program as follows. The subprogram is in an ASCII file on the E5250A Program Disk.

1. GET the file C_COMPEN from the E5250A Program Disk.

```
GET "C_COMPEN"
```

2. RE-STORE the file.

```
RE-STORE "C_COM"
```

3. Load your program.
4. Link the subprogram to your program by using the LOADSUB statement.

```
LOADSUB ALL FROM "C_COM"
```

Error Messages

If error occurs, following error message is displayed, and program is paused:

Parameter Out of Range Improper parameter value. Confirm and enter the available value.

7

Command Reference

Command Reference

This chapter describes the following for Agilent E5250A:

- SCPI commands available to control the E5250A via GPIB interface.

SCPI is a universal programming language for electronic test and measurement instruments, and is based on IEEE 488.1 and IEEE 488.2.

SCPI commands are divided into two types: *common commands* and *subsystem commands*.

Common commands are generally not measurement related, but are used to manage status registers, data storage, and so on. Common commands are defined by IEEE 488.2. All common commands begin with an asterisk, such as *RST.

Subsystem commands are mostly measurement related and some are general purpose. Subsystem commands have a hierarchical structure that uses a colon between mnemonics (keywords), such as :DIAG:TEST:CARD:RES.

Commands for the following subsystems are available for the E5250A:

DIAGnostic	commands for performing self-test.
ROUTE	commands for signal routing.
SYSTEM	commands for controlling other functions that are not related to instrument performance.

Commands are listed in alphabetical order in this chapter.

- Status reporting structure

These are IEEE 488.2 status structures (registers), which can be set or read by the common commands.

For SCPI programming to control the E5250A, refer to Chapter 6, “Programming the E5250A.”

For a quick reference list of all SCPI subsystem commands described in this chapter, refer to Chapter 12, “SCPI Command Summary.”

For error messages related to the SCPI commands, refer to Chapter 11, “Error Messages.”

Textual Notation for Subsystem Commands**CAPITAL LETTERS**

Capital letters are the minimally required letters of the command header. Lowercase letters are the long form (complete spelling), which you can omit if desired.

For example, for :SYSTem:CCONfig?, you only need to specify :SYST:CCON?.

[]

Square brackets are used to enclose optional information not required for execution of the command sequence.

For example, for the [:ROUTE]:BIAS:PORT command, you can execute :ROUT:BIAS:PORT or :BIAS:PORT, which are exactly the same.

italic font

Text you supply. For example, for *card_number*, you enter an allowed card number. Also, used to represent response data.

|

Vertical bar can be read as "or" and is used to separate alternative parameter options.

{ }

Braces (curly brackets) are used to enclose one or more parameters that may be included zero or more times.

< >

Angular brackets indicate that the word or words enclosed represent something other than themselves. For example, <newline>.

Common Commands

This section describes common commands and queries, which are commands defined by *IEEE 488.2*.

The following table shows some common commands that are supported for the E5250A.

Common Commands for E5250A

Mnemonic	Name
*CLS	Clear Status
*ESE(?)	Standard Event Status Enable Command (Query)
*ESR?	Standard Event Status Register Query
*IDN?	Identification Query
*OPC(?)	Operation Complete Command (Query)
*RST	Reset Command
*SRE(?)	Service Request Enable Command (Query)
*STB?	Read Status Byte Query
*TST?	Self-Test Query
*WAI	Wait-to-Continue Command

*CLS

This command clears the Status Byte Register, the Standard Event Status Register, and the Error Queue. This command does *not* clear the enable registers. Refer to “Status Reporting Structure” on page 7-48.

Also, this command stops the monitoring of pending operations by the *OPC command.

This command does not have query form.

Syntax *CLS

Example OUTPUT @Hp5250;"*CLS"

*ESE

This command sets the bits of the Standard Event Status "Enable" Register. 1 enables, 0 masks.

Syntax *ESE *enable_number*

Parameter	Explanation
<i>enable_number</i>	decimal integer (that is the sum of the binary-weighted values for the desired bits), hexadecimal, octal, or binary value

Query response *enable_number* <newline><^END>

enable_number is decimal integer value that is the sum of the binary-weighted values of the “Enable” register bits.

Semantics The Standard Event Status "Enable" Register determines which bits of the Standard Event Status Register are enabled. Enabled bits are ORed together, and the result is reported to bit5 of the Status Byte Register.

The Standard Event Status "Enable" Register consists of 16 bits, but only the lower 8 bits are used, which correspond to the bits of the Standard Event Status Register. For details, refer to “Standard Event Status Enable Register” on page 7-54

Command Reference

*ESE

The following table shows the bits of the Standard Event Status Register and binary-weighted *decimal* value of each bit.

bit	binary-weight	description
0	1	OPC (Operation Complete)
1	2	not used
2	4	QYE (Query ERROR)
3	8	DDE (Device-Dependent ERROR)
4	16	EXE (Execution ERROR)
5	32	CME (Command ERROR)
6	64	not used
7	128	PON (Power on)

Example

The following four lines enable the same bit (CME bit):

```
OUTPUT @Hp5250;"*ESE 32"           using decimal numeric
OUTPUT @Hp5250;"*ESE #B100000"    using binary numeric
OUTPUT @Hp5250;"*ESE #Q40"        using octal numeric
OUTPUT @Hp5250;"*ESE #H20"        using hexadecimal numeric
```

The following is example for query:

```
OUTPUT @Hp5250;"*ESE?"
ENTER @Hp5250;A
```

*ESR?

This query command returns the present contents of the Standard Event Status Register.

Syntax

*ESR?

Query response

register <newline><^END>

Parameter	Explanation
<i>register</i>	decimal integer value that is the sum of the binary-weighted values for the set bits

Semantics

The following table shows the bits of the Standard Event Status Register, and the binary-weighted *decimal* value of each bit.

bit	binary-weight	description
0	1	OPC (Operation Complete)
1	2	not used. always 0.
2	4	QYE (Query ERROR)
3	8	DDE (Device-Dependent ERROR)
4	16	EXE (Execution ERROR)
5	32	CME (Command ERROR)
6	64	not used. always 0.
7	128	PON (Power on)

Example

```
OUTPUT @Hp5250;"*ESR?"
ENTER @Hp5250;A
```

Command Reference

*IDN?

*IDN?

This query command returns the ID of your E5250A.

Syntax

*IDN?

Query response

HEWLETT-PACKARD,*model*,0,*revision* <newline><^END>

Response	Type	Explanation
<i>model</i>	character	model number. E5250A
<i>revision</i>	character	revision number. A.01.00 or later

Example

```
DIM A$[50]
OUTPUT @Hp5250;"*IDN?"
ENTER @Hp5250;A$
PRINT A$
```

An example result of above program is:

```
HEWLETT-PACKARD, E5250A, 0, A.01.00
```

*OPC

This command starts to monitor pending operations, and sets/clears the Operation Complete (OPC) bit in the Standard Event Status Register as follows:

- If there is no pending operation, sets the OPC bit to 1.
- If there are any pending operations, sets the OPC bit to 0. The bit will be set to 1 again when all pending operations are completed.

So, *OPC command is required to enable the OPC bit. To stop monitoring pending operations (disable OPC bit), execute the *CLS command.

For details about the Standard Event Status Register, refer to “Standard Event Status Register” on page 7-53. Also, see *WAI command.

Syntax

*OPC

Query response

1 <newline><^END>

*OPC? places ASCII character 1 into the Output Queue when all pending operations are completed. For details, refer to “Output Queue” on page 7-55.

Example

OUTPUT @Hp5250;"*OPC"

The following example is for query:

```
OUTPUT @Hp5250;"*OPC?"
ENTER @Hp5250;A
```

Command Reference

*RST

*RST

This command performs an instrument reset. Status after *RST is shown below:

Channel Configuration:	Normal Config Mode
Connection Rule:	Free
Connection Sequence:	Break Before Make
Bias Mode:	Off
Bias Port:	<ul style="list-style-type: none">• E5252A: 10• E5255A: None
Bias Enabled Channels:	All channels (output ports) are bias enabled
Couple Port Mode:	Off
Couple Port:	No Couple Port
Card Channel Status:	All relays open
Self-Test Result:	No Change

Syntax *RST

Example OUTPUT @Hp5250;"*RST"

NOTE This command does not change the self-test result.
For the power-on settings, see :SYSTEM:CPON.

***SRE**

This command sets the Service Request "Enable" Register bits.

1 enables, 0 masks.

Syntax

*SRE *enable_number*

Parameter	Explanation
<i>enable_number</i>	decimal integer (that is the sum of the binary-weighted values for the desired bits), hexadecimal, octal, or binary value

Query response

enable_number <newline><^END>

Semantics

The Service Request "Enable" Register consists of 8 bits: Bit0 to Bit7. Bit6 is not defined, and is always 0. The Service Request "Enable" Register determines which bits of the Status Byte Register are enabled.

The status of the enabled bits are ORed together, and the result of OR is output to bit6 (Master Summary Status bit) of Status Byte Register. For details, refer to "Status Reporting Structure" on page 7-48.

The following table shows the bits of the Status Byte Register, and the binary-weighted *decimal* value of each bit.

bit	binary-weight	description
0	1	not used
1	2	not used
2	4	not used
3	8	not used
4	16	MAV (Message Available summary-message)
5	32	ESB (Event Status Bit)
6	64	MSS (Master Summary Status)
7	128	not used

Command Reference

*SRE

Example

The following four lines enable the same bits (bit 4 and 5):

```
OUTPUT @Hp5250;"*SRE 48"           using decimal numeric
OUTPUT @Hp5250;"*SRE #B110000"    using binary numeric
OUTPUT @Hp5250;"*SRE #Q60"       using octal numeric
OUTPUT @Hp5250;"*SRE #H30"       using hexadecimal numeric
```

The following is example for query:

```
OUTPUT @Hp5250;"*SRE?"
ENTER @Hp5250;A
```

*STB?

This query command reads the Status Byte Register (reads Master Summary Status bit, not Request for Service Message).

For bit6, this command reads MSS, not Request for Service (RQS). Refer to “Status Reporting Structure” on page 7-48.

Syntax

*STB?

Query response

register <newline><^END>

Parameter	Explanation
<i>register</i>	decimal integer value that is the sum of the binary-weighted values for the set bits

Semantics

The following table shows the bits of the Status Byte Register, and the binary-weighted *decimal* value of each bit.

bit	binary-weight	description
0	1	not used. always 0.
1	2	not used. always 0.
2	4	not used. always 0.
3	8	not used. always 0.
4	16	MAV (Message Available summary-message)
5	32	ESB (Event Status Bit)
6	64	MSS (Master Summary Status)
7	128	not used. always 0.

Example

```
OUTPUT @Hp5250;"*STB?"
ENTER @Hp5250;A
```

Command Reference

*TST?

***TST?**

This query command executes an internal self-test, then returns the result. After this command execution, the E5250A becomes same status as after *RST command execution.

Syntax

*TST?

Query response

test_result <newline><^END>

<i>test_result</i>	Explanation
0	pass
1	fail

Example

```
OUTPUT @Hp5250;"*TST?"  
ENTER @Hp5250;A
```

***WAI**

This command stops execution of any commands until the Operation Complete (OPC) bit is set to 1, which means there is no pending operation. Refer to *OPC command.

Syntax

*WAI

Example

```
OUTPUT @Hp5250;"*WAI"
```

:DIAGnostic Subsystem

The :DIAGnostic subsystem has commands for executing the self-test function. For more info, see Chapter 3.

NOTE

The :DIAGnostic subsystem commands ignore the E5250A channel configuration mode. For :DIAG commands that require a card number, you specify 1, 2, 3, 4, or ALL.

:DIAGnostic Command Tree

Command	Parameter
:DIAGnostic	
:TEST	
:CARD	
:CLEAr	<i>card_number</i> ALL
[:EXECute]?	<i>card_number</i> ALL
:STATe?	<i>card_number</i>
:FRAMe	
:CLEAr	CONTroller FPANel
[:EXECute]?	CONTroller FPANel
:STATe?	CONTroller FPANel

Parameter values:

***card_number*:** 1 | 2 | 3 | 4

:DIAGnostic:TEST:CARD:CLEar

This command clears the relay test result (pass/fail result) of the specified card.

Syntax

:DIAGnostic:TEST:CARD:CLEar *card_number*

Parameter	Explanation
<i>card_number</i>	card number: 1, 2, 3, 4, or ALL

Example

OUTPUT @Hp5250;":DIAG:TEST:CARD:CLE 1"

:DIAGnostic:TEST:CARD[:EXECute]?

This command executes the relay test for specified card, then returns the pass/fail result. For more info, see Chapter 3.

NOTE

You must attach the relay test adapter before executing this command.

This command changes all settings of card to same state as after executing :SYST:CPON command.

Syntax

:DIAGnostic:TEST:CARD[:EXECute]? *card_number*

Parameter	Explanation
<i>card_number</i>	card number: 1, 2, 3, 4, or ALL

Query response

test_result <newline><^END>

1 : Fail card exists

0 : Pass

Example

OUTPUT @Hp5250;":DIAG:TEST:CARD? ALL"

:DIAGnostic:TEST:CARD:STATe?

This command returns the most recent relay test result for the specified card.

Syntax

:DIAGnostic:TEST:CARD:STATe? *card_number*

Parameter	Explanation
<i>card_number</i>	card number: 1, 2, 3, 4

Query response

test_result <newline><^END>

1 : Fail
0 : Pass
-1 : Not Tested

Example

OUTPUT @Hp5250;":DIAG:TEST:CARD:STAT? 1"
ENTER @Hp5250;A

:DIAGnostic:TEST:FRAME:CLEAr

This command clears test result of the specified E5250A test.

Syntax

:DIAGnostic:TEST:FRAME:CLEAr CONTroller | FPANel

Parameter	Explanation
CONTroller	Controller test
FPANel	Front panel interface test

Example

OUTPUT @Hp5250;":DIAG:TEST:FRAM:CLE CONT"

:DIAGnostic:TEST:FRAMe[:EXECute]?

This command executes the specified E5250A test, then returns the test result. For more info, see Chapter 3.

After :DIAG:TEST:FRAM:EXEC CONT execution, the E5250A status becomes same as after *RST command execution.

After :DIAG:TEST:FRAM:EXEC FPAN execution, the E5250A status is *not* changed.

NOTE

The :DIAG:TEST:FRAM:EXEC FPAN command requires key input from the front panel. If key is not pressed within 10 seconds, this test result will be fail.

Syntax

:DIAGnostic:TEST:FRAMe[:EXECute]? CONTroller | FPANel

Parameter	Explanation
CONTroller	Controller test
FPANel	Front panel interface test

Query response

test_result <newline><^END>

1 : Fail

0 : Pass

Example

OUTPUT @Hp5250;":DIAG:TEST:FRAM? CONT"

:DIAGnostic:TEST:FRAMe:STATe?

This command returns the most recent test result (pass/fail) of the specified E5250A test.

Syntax

```
:DIAGnostic:TEST:FRAMe:STATe? CONTroller | FPANel
```

Parameter	Explanation
CONTroller	Controller test
FPANel	Front panel interface test

Query response

```
test_result <newline><^END>
```

```
1 : Fail  
0 : Pass  
-1 : Not Tested
```

Example

```
OUTPUT @Hp5250;":DIAG:TEST:FRAM:STAT? CONT"  
ENTER @Hp5250;A
```

:ROUte Subsystem

The :ROUte subsystem has commands for controlling the signal routing.

"Open a channel": opens relays to disconnect the channel (that is, disconnects input port from output port).

"Close a channel": closes relays to connect the channel (that is, connects input port to output port).

:ROUte Command Tree

Command	Parameter
[:ROUte]	
:BIAS	
:CHANnel	
:DISAble	
:CARd	<i>card_number</i> ALL
[:LIST]	(@channel_list)
[:LIST]?	(@channel_list)
:ENABle	
:CARd	<i>card_number</i> ALL
[:LIST]	(@channel_list)
[:LIST]?	(@channel_list)
:PORT	<i>card_number</i> ALL, bias_port
:PORT?	<i>card_number</i>
[:STATe]	<i>card_number</i> ALL, state
[:STATe]?	<i>card_number</i>
:CLOSE	
:CARd?	<i>card_number</i>
[:LIST]	(@channel_list)
[:LIST]?	(@channel_list)

Command	Parameter
[:ROUTE]	
:CONNECTION	
:RULE	<i>card_number</i> ALL, <i>rule</i>
:RULE?	<i>card_number</i>
:SEQUENCE	<i>card_number</i> ALL, <i>sequence</i>
:SEQUENCE?	<i>card_number</i>
:COUPLE	
:PORT	<i>card_number</i> ALL, 'couple_port'
:PORT?	<i>card_number</i>
[:STATE]	<i>card_number</i> ALL, <i>state</i>
[:STATE]?	<i>card_number</i>
:FUNCTION	<i>channel_config</i>
:FUNCTION?	
:OPEN	
:CARD	<i>card_number</i> ALL
[:LIST]	(@ <i>channel_list</i>)
[:LIST]?	(@ <i>channel_list</i>)

Parameter values:

card_number: Auto Config Mode: 0
Normal Config Mode: 1 | 2 | 3 | 4

channel_list: Refer to Chapter 5.

state: ON | OFF | 0 | 1

rule: FREE | SROU

channel_config: ACON | NCON

sequence: NSEQ | BBM | MBBR

[:ROUte]:BIAS:CHANnel:DISable:CARD

This command bias disables all output ports of the specified card.

When Bias Mode is ON, this command opens relays to disconnect the input Bias Port from all output ports. Refer to "ROUte:BIAS:STATe".

At *RST, all output ports are bias enabled.

Syntax

`[:ROUte]:BIAS:CHANnel:DISable:CARD card_number`

Parameter	Explanation
<i>card_number</i>	card number: For Auto Config mode: 0 or ALL For Normal Config mode: 1, 2, 3, 4, or ALL

Example

```
OUTPUT @Hp5250;":ROUT:BIAS:CHAN:DIS:CARD ALL"
```

[:ROUte]:BIAS:CHANnel:DISable[:LIST]

This command bias disables the output ports specified by the *channel_list*.

When Bias Mode is ON, this command opens relays to disconnect the input Bias Port from the output ports specified by *channel_list*. Refer to "ROUte:BIAS:STATe".

At *RST, all output ports are bias enabled.

Syntax

`[:ROUte]:BIAS:CHANnel:DISable[:LIST] (@channel_list)`

Parameter	Explanation
<i>channel_list</i>	Channels to bias disable. For details about <i>channel_list</i> , refer to Chapter 5.

The input ports specified by the *channel_list* are ignored. The input port is always the input Bias Port. So, in the *channel_list*, only the card numbers and output ports have meaning. But you cannot omit the input port in the *channel_list*.

Example

```
OUTPUT @Hp5250;":ROUT:BIAS:CHAN:DIS (@10301,10402)"
```

In above example, the input Bias Port on card 1 is disabled for output ports 1 and 2. Specified input ports 3 and 4 are ignored because the input port is always the input Bias Port.

[:ROUte]:BIAS:CHANnel:DISable[:LIST]?

This query command returns 0 or 1 for each channel specified by *channel_list*, in same order as specified by *channel_list*.

1: channel is bias disabled, 0: channel is bias enabled.

Syntax

[:ROUte]:BIAS:CHANnel:DISable[:LIST]? (@*channel_list*)

Parameter	Explanation
<i>channel_list</i>	Channels to check. For details about <i>channel_list</i> , refer to Chapter 5.

The input ports specified by the *channel_list* are ignored. The input port is always the input Bias Port. So, in the *channel_list*, only the card numbers and output ports have meaning. But you cannot omit the input port in the *channel_list*.

Query response

disable_status{,*disable_status*} <newline><^END>

1 : disabled

0 : enabled

Example

```
OUTPUT @Hp5250;":ROUT:BIAS:CHAN:ENAB:CARD ALL"
OUTPUT @Hp5250;":ROUT:BIAS:CHAN:DIS (@10101)"
OUTPUT @Hp5250;":ROUT:BIAS:CHAN:DIS? (@10101,10102,10201)"
ENTER @Hp5250;A$
```

In above example, A\$ will be as follows:

1, 0, 1

10101 and 10201 have the same meaning because the specified input port is ignored.

[:ROUTe]:BIAS:CHANnel:ENABLE:CARD

This command bias enables all output ports of the specified card.

When Bias Mode is ON, this command closes relays to connect the input Bias Port to all output ports that are *not* already connected (by :ROUT:CLOS command) to other input ports.

Refer to "ROUTe:BIAS:STATe".

At *RST, all output ports are bias enabled.

Syntax

[:ROUTe]:BIAS:CHANnel:ENABle:CARD *card_number*

Parameter	Explanation
<i>card_number</i>	card number: For Auto Config mode: 0 or ALL For Normal Config mode: 1, 2, 3, 4, or ALL

Example

```
OUTPUT @Hp5250;":ROUT:BIAS:CHAN:ENAB:CARD ALL"
```

[:ROUte]:BIAS:CHANnel:ENABle[:LIST]

This command bias enables the output ports specified by *channel_list*.

When Bias Mode is ON, this command closes relays to connect the input Bias Port to the output ports specified by *channel_list*.

Refer to "ROUte:BIAS:STATe". Output ports that are already connected to another input port cannot be connected to the input Bias Port.

At *RST, all output ports are bias enabled.

Syntax

```
[ :ROUte ] :BIAS :CHANnel :ENABle [ :LIST ] (@channel_list)
```

Parameter	Explanation
<i>channel_list</i>	Channels to bias enable. For details about <i>channel_list</i> , refer to Chapter 5.

The input ports specified by the *channel_list* are ignored. The input port is always the input Bias Port. So, in the *channel_list*, only the card numbers and output ports have meaning. But you cannot omit the input port in the *channel_list*.

Example

```
OUTPUT @Hp5250; ":ROUT:BIAS:CHAN:ENAB (@10401,10502) "
```

In above example, the input Bias Port on card 1 is enabled for output ports 1 and 2. Specified input ports 4 and 5 are ignored because input port is always the input Bias Port.

[[:ROUte]:BIAS:CHANnel:ENABLE[:LIST]?

This query command returns 0 or 1 for each channel specified by *channel_list*, in same order as specified by *channel_list*.

0: channel is bias disabled, 1: channel is bias enabled.

Syntax

[[:ROUte]:BIAS:CHANnel:ENABLE[:LIST]? (@*channel_list*)

Parameter	Explanation
<i>channel_list</i>	Channels to check. For details about <i>channel_list</i> , refer to Chapter 5.

The input ports specified by the *channel_list* are ignored. The input port is always the input Bias Port. So, in the *channel_list*, only the card numbers and output ports have meaning. But you cannot omit the input port in the *channel_list*.

Query response

enable_status{,*enable_status*} <newline><^END>

1 : enabled

0 : disabled

Example

```
OUTPUT @Hp5250;":ROUT:BIAS:CHAN:DIS:CARD ALL"
OUTPUT @Hp5250;":ROUT:BIAS:CHAN:ENAB (@10101)"
OUTPUT @Hp5250;":ROUT:BIAS:CHAN:ENAB? (@10101,10102,10201)"
ENTER @Hp5250;A$
```

In above example, A\$ will be as follows:

1, 0, 1

10101 and 10201 have the same meaning because the specified input port is ignored.

[:ROUte]:BIAS:PORT

NOTE

This command applies only to the E5252A card.

For the E5255A card, the input Bias Port cannot be selected, and is always the built-in Bias Port.

The Bias Port and Couple Port cannot be set to same port number.

This command selects which input port is the Bias Port on the specified card. For each card, you can specify the same or different Bias Port. For details, refer to "Bias Mode" in Chapter 5.

At *RST, Bias Port is set to 10 for the E5252A.

Syntax

[[:ROUte]][:BIAS:PORT] *card_number,bias_port*

Parameter	Explanation
<i>card_number</i>	card number: For Auto Config mode: 0 or ALL For Normal Config mode: 1, 2, 3, 4, or ALL
<i>bias_port</i>	Input port number: 1 to 10.

Example

```
OUTPUT @Hp5250;":ROUT:BIAS:PORT ALL,6"
```

[:ROUte]:BIAS:PORT?

NOTE

This command applies only to the E5252A card.

For the E5255A card, the input Bias Port cannot be selected, and is always the built-in Bias Port.

This query command returns the input Bias Port number for the specified card.

Syntax

[[:ROUte]][:BIAS:PORT? *card_number*

Parameter	Explanation
<i>card_number</i>	card number: For Auto Config mode: 0 For Normal Config mode: 1, 2, 3, or 4

Query response

port_number <newline><^END>

port_number = 1 to 10

Example

```
OUTPUT @Hp5250;":ROUT:BIAS:PORT ALL,4"  
OUTPUT @Hp5250;":ROUT:BIAS:PORT? 1"  
ENTER @Hp5250;A
```

For above example, A will be as follows:

4

[:ROUte]:BIAS[:STATe]

This command controls the Bias Mode for the specified card. For details, refer to "Bias Mode" in Chapter 5.

When Bias Mode is ON, the input Bias Port is connected to all *bias enabled* output ports that are not connected to any other input ports. To bias enable the desired output ports, refer to :ROUT:BIAS:CHAN:ENAB:CARD or :ROUT:BIAS:CHAN:ENAB:LIST.

To select the input Bias Port, refer to :ROUT:BIAS:PORT.

When Bias Mode is ON, you cannot directly specify Bias Port connections by :ROUT:OPEN or :ROUT:CLOSE. Refer to those commands for details.

Bias disabled output ports are never connected to the input Bias Port when Bias Mode is ON.

When Bias Mode is OFF, the input Bias Port is the same as the other input ports, so relays can be controlled directly to connect to output ports.

At *RST, the value of this parameter is OFF.

Syntax

[[:ROUte]:BIAS[:STATe] *card_number,state*

Parameter	Explanation
<i>card_number</i>	card number: For Auto Config mode: 0 or ALL For Normal Config mode: 1, 2, 3, 4, or ALL
<i>state</i>	ON or 1: turn ON the Bias Mode OFF or 0: turn OFF the Bias Mode

Example

```
OUTPUT @Hp5250;":ROUT:BIAS:STAT ALL,ON"
```

[:ROUte]:BIAS[:STATe]?

This query command returns the Bias Mode of the specified card.

Syntax

[:ROUte] :BIAS [:STATe] ? *card_number*

Parameter	Explanation
<i>card_number</i>	card number: For Auto Config mode: 0 For Normal Config mode: 1, 2, 3, or 4

Query response

0 or 1 <newline><^END>

0: Bias Mode is OFF

1: Bias Mode is ON

Example

```
OUTPUT @Hp5250;":ROUT:BIAS:STAT ALL,ON"  
OUTPUT @Hp5250;":ROUT:BIAS:STAT? 4"  
ENTER @Hp5250;A
```

In above example, A will be 1.

[:ROUte]:CLOSe:CARD?

This query command returns *channel_list* of all closed (connected) channels for the specified card.

Syntax

[:ROUte] :CLOSe:CARD? *card_number*

Parameter	Explanation
<i>card_number</i>	card number: For Auto Config mode: 0 For Normal Config mode: 1, 2, 3, or 4

Query response

channel_list <newline><^END>

Example

```
OUTPUT @Hp5250;":ROUT:OPEN:CARD ALL"  
OUTPUT @Hp5250;":ROUT:CLOS (@10101,10202) "  
OUTPUT @Hp5250;":ROUT:CLOS:CARD? 1"  
ENTER @Hp5250;A$
```

A\$ will be @10101, 10202. For the meaning of *channel_list*, refer to Chapter 5.

[:ROUte]:CLOSe[:LIST]

This command connects the input ports to the output ports as specified in *channel_list*.

For some modes (such as Single Route Mode, Couple Port Mode, and Bias Mode), more complex connections may occur. For details, refer to Chapter 5.

For example, if Bias Mode is ON, you cannot directly specify the input Bias port. But if *channel_list* specifies an output port that is connected to the input Bias Port, the output port is automatically disconnected from the Bias Port and connected to specified input port. Refer to ":ROUte:BIAS:STATe".

Syntax

[:ROUte] :CLOSe [:LIST] (@*channel_list*)

Parameter	Explanation
<i>channel_list</i>	Channels to close. For details about <i>channel_list</i> , refer to Chapter 5.

Example

```
OUTPUT @Hp5250;":ROUT:CLOS (@10101,10202) "
```

[:ROUte]:CLOSe[:LIST]?

This query command returns 0 or 1 for each channel specified by *channel_list*, in same order as specified by *channel_list*.

0: channel is opened (not connected), 1: channel is closed (connected).

Syntax

[:ROUte] :CLOSe [:LIST] ? (@*channel_list*)

Parameter	Explanation
<i>channel_list</i>	Channels to check. For details about <i>channel_list</i> , refer to Chapter 5.

Query response

```
close_status{,close_status} <newline><^END>
```

1 : closed, or 0 : opened

Example

```
OUTPUT @Hp5250;":ROUT:CLOS (@10101,10202) "
OUTPUT @Hp5250;":ROUT:CLOS? (@10101,10102,10201,10202) "
ENTER @Hp5250;A$
```

In above example, A\$ will be 1, 0, 0, 1.

[:ROUte]:CONNection:RULE

This command sets the connection rule (Free or Single Route) for the specified card. For details, refer to "Connection Rule" in Chapter 5.

At *RST, all cards are set to FREE.

Syntax

`[:ROUte]:CONNection:RULE card_number,rule`

Parameter	Explanation
<i>card_number</i>	card number: For Auto Config mode: 0 or ALL For Normal Config mode: 1, 2, 3, 4, or ALL
<i>rule</i>	FREE: free route SROUte: single route

Example

OUTPUT @Hp5250;":ROUT:CONN:RULE ALL,SROU"

[:ROUte]:CONNection:RULE?

This query command returns the connection rule of the specified card. For details, refer to "Connection Rule" in Chapter 5.

Syntax

`[:ROUte]:CONNection:RULE? card_number`

Parameter	Explanation
<i>card_number</i>	card number: For Auto Config mode: 0 For Normal Config mode: 1, 2, 3, or 4

Query response

FREE or SROU <newline><^END>

Example

OUTPUT @Hp5250;":ROUT:CONN:RULE ALL,SROU"
OUTPUT @Hp5250;":ROUT:CONN:RULE? 1"
ENTER @Hp5250;A\$

In above example, A\$ will be SROU.

[:ROUte]:CONNection:SEQuence

This command specifies the connection sequence mode, which is the open/close sequence of the relays when connection route is changed from an existing connection to a new connection. For details, refer to "Connection Sequence" in Chapter 5.

The connection sequence is used only for cards that have been set to SROUte connection rule. Refer to "ROUte:CONNection:RULE".

At *RST, BBMake is selected.

Syntax

`[:ROUte]:CONNection:SEQuence card_number,sequence`

Parameter	Explanation
<i>card_number</i>	card number: For Auto Config mode: 0 or ALL For Normal Config mode: 1, 2, 3, 4, or ALL
<i>sequence</i>	NSEQ: No-Sequence mode BBM: Break-Before-Make mode MBBR: Make-Before-Break mode

Example

OUTPUT @Hp5250;":ROUT:CONN:SEQ ALL,MBBR"

[[:ROUte]:CONNection:SEQuence?

This query command returns the connection sequence mode of the specified card. For details, refer to "Connection Sequence" in Chapter 5.

Syntax

[[:ROUte]:CONNection:SEQuence? *card_number*

Parameter	Explanation
<i>card_number</i>	card number: For Auto Config mode: 0 For Normal Config mode: 1, 2, 3, or 4

Query response

NSEQ or BBM or MBBR <newline><^END>

Example

```
OUTPUT @Hp5250;":ROUT:CONN:SEQ ALL,MBBR"  
OUTPUT @Hp5250;":ROUT:CONN:SEQ? 0"  
ENTER @Hp5250;A$
```

In above example, A\$ will be as follows:

```
MBBR
```

[:ROUte]:COUPle:PORT

NOTE

This command applies only to the E5252A card.

The Couple Port function is not available for the E5255A card.

The Bias Port and Couple Port cannot be set to same port number.

This command is used to set up couple ports, which are used for making Kelvin connections. For details, refer to "Couple Ports" in Chapter 5.

Each specified input port number will be coupled with the next input port and two output ports. The two output ports are determined by the :ROUT:CLOS command, and the lower output port number is always odd. See example below.

To turn Couple Port Mode ON/OFF, refer to :ROUT:COUP:STAT.

For each card, you can set up the same or different couple ports.

This command overwrites the previous couple port setting for the card.

At *RST, no input ports are coupled.

Syntax

[:ROUte]:COUPle:PORT *card_number*,*'couple_port'*

Parameter	Explanation
<i>card_number</i>	card number: For Auto Config mode: 0 or ALL For Normal Config mode: 1, 2, 3, 4, or ALL
<i>couple_port</i>	One or more input port numbers: 1, 3, 5, 7, or 9. Enclose by single quotation marks. Separate multiple input port numbers by comma. For example: '1, 5'

Example

```
OUTPUT @Hp5250;":ROUT:COUP:PORT ALL,'1'"
OUTPUT @Hp5250;":ROUT:CLOS (@10103)"
```

This example connects input port 1 to output port 3, and connects input port 2 to output port 4.

The lower output port of the couple port is always the odd number port, even if you specify an even output port in the :ROUT:CLOS command. For example, if you used :ROUT:CLOS (@10104), the connections would be the same as above.

[:ROUte]:COUPle:PORT?

NOTE

This command applies only to the E5252A card.

This query command returns the *lower* input port number of each coupled pair. For details, refer to "Couple Ports" in Chapter 5.

Syntax

[:ROUte]:COUPle:PORT? *card_number*

Parameter	Explanation
<i>card_number</i>	card number: For Auto Config mode: 0 For Normal Config mode: 1, 2, 3, or 4

Query response

port_number{,*port_number*} <newline><^END>

port_number = 1 or 3 or 5 or 7 or 9

Example

```
OUTPUT @Hp5250;":ROUT:COUP:PORT ALL,'1,3'"
OUTPUT @Hp5250;":ROUT:COUP:PORT? 1"
ENTER @Hp5250;A$
```

In above example, A\$ will be as follows:

1, 3

[:ROUte]:COUPle[:STATe]

NOTE

This command applies only to the E5252A card.

The Couple Port function is not available for the E5255A card.

This command controls the Couple Port Mode for the specified card. For details, refer to "Couple Ports" in Chapter 5.

To set up the couple ports, refer to :ROUT:COUP:PORT.

At *RST, the value of this parameter is OFF.

Syntax

[[:ROUte]:COUPle[:STATe] *card_number,state*

Parameter	Explanation
<i>card_number</i>	card number: For Auto Config mode: 0 or ALL For Normal Config mode: 1, 2, 3, 4, or ALL
<i>state</i>	ON or 1: turn ON the Couple Port Mode OFF or 0: turn OFF the Couple Port Mode

Example

OUTPUT @Hp5250;":ROUT:COUP:STAT ALL,ON"

[:ROUte]:COUple[:STATe]?

NOTE

This command applies only to the E5252A card.

The Couple Port function is not available for the E5255A card.

This query command returns the Couple Port Mode of the specified card. For details, refer to "Couple Ports" in Chapter 5.

Syntax

[:ROUte]:COUple[:STATe]? *card_number*

Parameter	Explanation
<i>card_number</i>	card number: For Auto Config mode: 0 For Normal Config mode: 1, 2, 3, or 4

Query response

0 or 1 <newline><^END>

0 : Couple Port Mode is OFF

1 : Couple Port Mode is ON.

Example

```
OUTPUT @Hp5250;":ROUT:COUP:STAT ALL,ON"  
OUTPUT @Hp5250;":ROUT:COUP:STAT? 2"  
ENTER @Hp5250;A
```

For above example, A will be as follows:

1

[:ROUte]:FUNction

This command sets the channel configuration, which determines how you specify the *channel_list* or *card_number* in other commands. For details, refer to "Channel List and Channel Configuration" in Chapter 5.

When configuration is changed by :ROUT:FUNC, all channels are opened (disconnected) and become same status as after SYSTem:CPON ALL command execution.

At *RST, this parameter is set to NCONfig.

Syntax

[:ROUte]:FUNction *channel_config*

Parameter	Explanation
<i>channel_config</i>	ACONfig: Auto Config Mode NCONfig: Normal Config Mode

Example

```
OUTPUT @Hp5250;":ROUT:FUNC ACON"
```

[:ROUte]:FUNction?

This query command returns the present channel configuration.

For details, refer to "Channel List and Channel Configuration" in Chapter 5.

Syntax

[:ROUte]:FUNction?

Query response

ACON or NCON <newline><^END>

Example

```
OUTPUT @Hp5250;":ROUT:FUNC ACON"
OUTPUT @Hp5250;":ROUT:FUNC?"
ENTER @Hp5250;A$
```

In above example, A\$ will be as follows:

```
ACON
```

[:ROUte]:OPEN:CARD

This command disconnects all input ports from all output ports for the specified card. Then, if Bias Mode is ON, connects the input Bias Port to all *bias enabled* output ports.

For details about the Bias Mode, refer to ":ROUte:BIAS:STATE" in this chapter and refer to Chapter 5.

Syntax

```
[ :ROUte ] :OPEN:CARD card_number
```

Parameter	Explanation
<i>card_number</i>	card number: For Auto Config mode: 0 or ALL For Normal Config mode: 1, 2, 3, 4, or ALL

Example

```
OUTPUT @Hp5250;":ROUT:OPEN:CARD ALL"
```

[:ROUte]:OPEN[:LIST]

This command disconnects the input ports from output ports as specified in *channel_list*.

For some modes (such as Single Route Mode, Couple Port Mode, and Bias Mode), more complex disconnections may occur. For details, refer to Chapter 5.

For example, if Bias Mode is ON, you cannot directly specify the input Bias port. But if you use :ROUT:OPEN to disconnect a *bias enabled* output port from another input port, the output port is automatically connected to the input Bias Port.

Syntax

```
[ :ROUte ] :OPEN[:LIST] (@channel_list)
```

Parameter	Explanation
<i>channel_list</i>	Channels to open (disconnect). For details about <i>channel_list</i> , refer to Chapter 5.

Example

```
OUTPUT @Hp5250;":ROUT:OPEN (@10101,10202) "
```

[:ROUte]:OPEN[:LIST]?

This query command returns 0 or 1 for each channel specified by *channel_list*, in same order as specified by *channel_list*.

0: channel is closed (connected), 1: channel is opened (not connected).

Syntax

[:ROUte] :OPEN [:LIST] ? (@*channel_list*)

Parameter	Explanation
<i>channel_list</i>	Channels to check. For details about <i>channel_list</i> , refer to Chapter 5.

Query response

open_status{,*open_status*} <newline><^END>

1 : opened

0 : closed

Example

```
OUTPUT @Hp5250;":ROUT:OPEN:CARD ALL"
OUTPUT @Hp5250;":ROUT:CLOS (@10101,10202) "
OUTPUT @Hp5250;":ROUT:OPEN? (@10101,10102,10201,10202) "
ENTER @Hp5250;A$
```

In above example, A\$ will be as follows:

0,1,1,0

:SYSTem Subsystem

The :SYSTem subsystem is a collection of functions that are not related to instrument performance.

:SYSTem Command Tree

Command	Parameter
:SYSTem	
:CCONfig?	<i>card_number</i>
:CDEscription?	<i>card_number</i>
:CPON	<i>card_number</i> ALL
:CTYPe?	<i>card_number</i>
:ERRor?	
:VERSion?	

Parameter values:

***card_number*:** Auto Config Mode: 0
Normal Config Mode: 1 | 2 | 3 | 4

:SYSTem:CCONfig?

This query command returns the card configuration information. This command has query form *only*.

Syntax

:SYSTem:CCONfig? *card_number*

Parameter	Explanation
<i>card_number</i>	card number: 1, 2, 3, or 4

Query response

card_configuration <newline><^END>

For the E5252A: no response. Always returns #10.

For the E5255A: definite length block response data, #16*ABCDEF*, where each letter is 8-bit binary data as follows:

A: indicates input port (1 to 6) that is connected to block 1.

B: indicates if resistance is set for block 1 Bias Port: 1: resistance set, 0: not set

C: indicates input port (1 to 6) that is connected to block 2.

D: indicates if resistance is set for block 2 Bias Port: 1: resistance set, 0: not set

E: indicates input port (1 to 6) that is connected to block 3.

F: indicates if resistance is set for block 3 Bias Port: 1: resistance set, 0: not set

Example

```
OUTPUT @Hp5250;":SYST:CCON? 1"
ENTER @Hp5250;A$
ENTER A$ USING "3X,6A";B$
FOR I=1 TO 6
  C=NUM(B$[I;1])
  PRINT "BYTE No. ";I;"=" ";C
NEXT I
```

:SYSTem:CDEscription?

This query command returns a description of the specified card.

This command has query form *only*.

Syntax

:SYSTem:CDEscription? *card_number*

Parameter	Explanation
<i>card_number</i>	card number: For Auto Config mode: 0 For Normal Config mode: 1, 2, 3, or 4

Query response

"*card_description*" <newline><<^END>

NOTE

If designated card is not installed or initialize failed, this command returns "No Card".

- For E5252A in Auto Config mode, "*card_description*" response is one of following:
 - "E5252A 10x12 Matrix Switch"
 - "E5252A 10x24 Matrix Switch"
 - "E5252A 10x36 Matrix Switch"
 - "E5252A 10x48 Matrix Switch"
- For E5252A in Normal Config mode:
"E5252A 10x12 Matrix Switch"
- For E5255A in Auto Config mode:
"E5255A I1,I2,I3,I4,I5,I6 Channel Multiplexer"
Where *In* is the number (two characters) of output ports for each input port *n*.
For example:
"E5255A 24,24, 0,16,16,16 Channel Multiplexer"
- For E5255A in Normal Config mode:
"E5255A 24 (8x3) Channel Multiplexer"

Example

```
OUTPUT @Hp5250;":SYST:CDES? 1"  
ENTER @Hp5250;A$
```

:SYSTem:CPON

This command resets the specified card to the power-on state. If the parameter is ALL, all addressable cards are reset to the power-on state. Status after this command is shown below:

Channel Configuration:	No Change
Connection Rule:	Free
Connection Sequence:	Break Before Make
Bias Mode:	Off
Bias Port:	<ul style="list-style-type: none"> • E5252A : 10 • E5255A : None
Bias Enabled Channels:	All channels (output ports) are bias enabled
Couple Port Mode:	Off
Couple Port:	No Couple Ports
Card Channel Status:	All relays open in present channel configuration mode
Self-Test Result:	No Change

For the device reset state, see *RST.

Syntax

:SYSTem:CPON *card_number*

Parameter	Explanation
<i>card_number</i>	card number: For Auto Config mode: 0 or ALL For Normal Config mode: 1, 2, 3, 4, or ALL

Example

```
OUTPUT @Hp5250;":SYST:CPON ALL"
```

:SYSTem:CTYPE?

This query command returns the ID of the specified card.

This command has query form *only*.

Syntax

:SYSTem:CTYPE? *card_number*

Parameter	Explanation
<i>card_number</i>	card number: For Auto Config mode: 0 For Normal Config mode: 1, 2, 3, or 4

Query response

HEWLETT-PACKARD,*model*,0,*revision* <newline><^END>

model = E5252A or E5255A

revision = A.01.00 or later version

NOTE

If designated card is not installed or initialize failed, this command returns
NONE,NONE,0,0

Example

```
OUTPUT @Hp5250;":SYST:CTYPE? 1"  
ENTER @Hp5250;A$
```

:SYSTem:ERRor?

This command reads the error from the head of the error queue and removes that error from the queue.

This command has query form *only*.

Syntax :SYSTem:ERRor?

Query response *err_no*,"*message*" <newline><^END>

err_no is numeric response data, and *message* is string response data.

If there has been no error (error queue is empty), the response to this query is as follows:

```
0, "No error"
```

Example OUTPUT @Hp5250;":SYST:ERR?"
ENTER @Hp5250;A,B\$

:SYSTem:VERSion?

This command returns the SCPI version number for which the E5250A complies.

This command has query form *only*.

Syntax :SYSTem:VERSion?

Query response *YYYY.V* <newline><^END>

YYYY is the year (for example, 1995).

V is the approved revision number for that year.

Example OUTPUT @Hp5250;":SYST:VERS?"
ENTER @Hp5250;A\$

Status Reporting Structure

This section describes the status reporting structure used in the E5250A. These are IEEE 488.2 status structures that can be set and read by the SCPI Common Commands as described in “Common Commands” on page 7-4.

Status Reporting Structure

The status reporting structure consists of the following:

- Status Byte Register
- Service Request "Enable" Register
- Standard Event Status Register
- Standard Event Status "Enable" Register
- Output Queue

In general, the status reporting structure is used to request service via Service Request (SRQ) or to indicate a specific condition, such as operation complete.

Refer to the following figures for a model of the E5250A status reporting structure.

Figure 7-1 Status Reporting Structure of E5250A

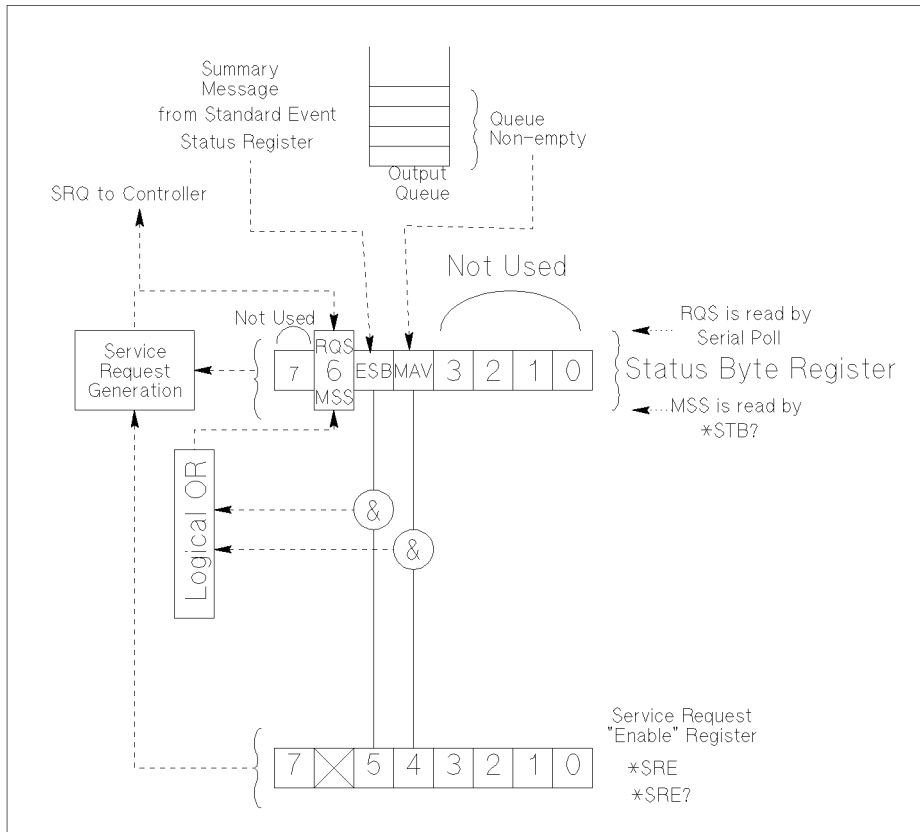

PG04001 120x120

The above figure shows Service Request Generation. When a condition occurs that requires service, the instrument sets Request Service bit (RQS – bit6) of Status Byte, and sends a Service Request (SRQ) via GPIB bus to the controller. So, the controller can execute an interrupt service routine (must be in the program) that uses a Serial Poll to read Status Byte of each instrument to determine which instrument requested service. See “Status Byte Register” on page 7-50.

Status Byte Register

The E5250A Status Byte Register contains bits (ESB and MAV) for status summary messages from other registers. The status of these bits depends on the condition of the Standard Event Status Register and the Output Queue. If service request occurs, Bit6 (RQS) of Status Byte Register is set.

Refer to Figure 7-2 and Table 7-1 for the E5250A Status Byte Register.

Figure 7-2 Status Byte Register of E5250A

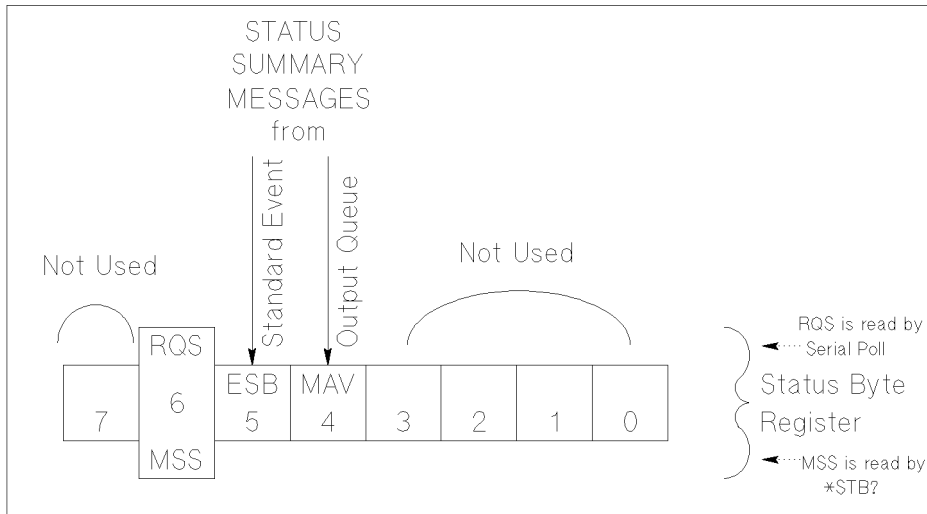

PG04002 120x80

The Status Byte Register can be read with either a serial poll or the *STB? common query command (refer to “Common Commands” on page 7-4).

Serial poll is a low-level GPIB command that can be executed by SPOLL in HP BASIC, such as the following:

```
Status=SPOLL (@Hp5250)
```

Both serial poll and STB? read the Status Byte Register identically, but have following difference:

- SPOLL returns RQS for bit6
- *STB? returns MSS for bit6

RQS and MSS are always the same value, so returned Status Byte value is always the same for these two methods.

In general, use serial polling (not *STB?) inside interrupt service routines. Use *STB? in other cases (not in interrupt service routine) when you want to know the value of Status Byte.

Table 7-1 **Status Byte Register of E5250A**

Bit	Definition	Explanation
0	Not Used.	Always zero.
1	Not Used.	Always zero.
2	Not Used.	Always zero.
3	Not Used.	Always zero.
4	Message Available (MAV) Queue Summary Message	Indicates whether Output Queue is empty. If unread message exists, this bit is set to 1. Otherwise, this bit is set to 0. Refer to "Output Queue" on page 7-55.
5	Standard Event Status Bit (ESB) Summary Message	Indicates whether one or more of the enabled Standard Events Status Register bits is set.
6	Request Service (RQS) Message	Indicates whether a SRQ (Service Request) has occurred. Read by Serial Poll.
	Master Summary Status (MSS) Summary Message	Indicates that the instrument has at least one reason for requesting service. Read by *STB?.
7	Not Used.	Always zero.

Service Request Enable Register

The Service Request Enable Register is an 8-bit register that can be used by the programmer to select which summary messages in the Status Byte Register may cause service requests. Refer to Figure 7-3.

Figure 7-3

Service Request Enable Register of E5250A

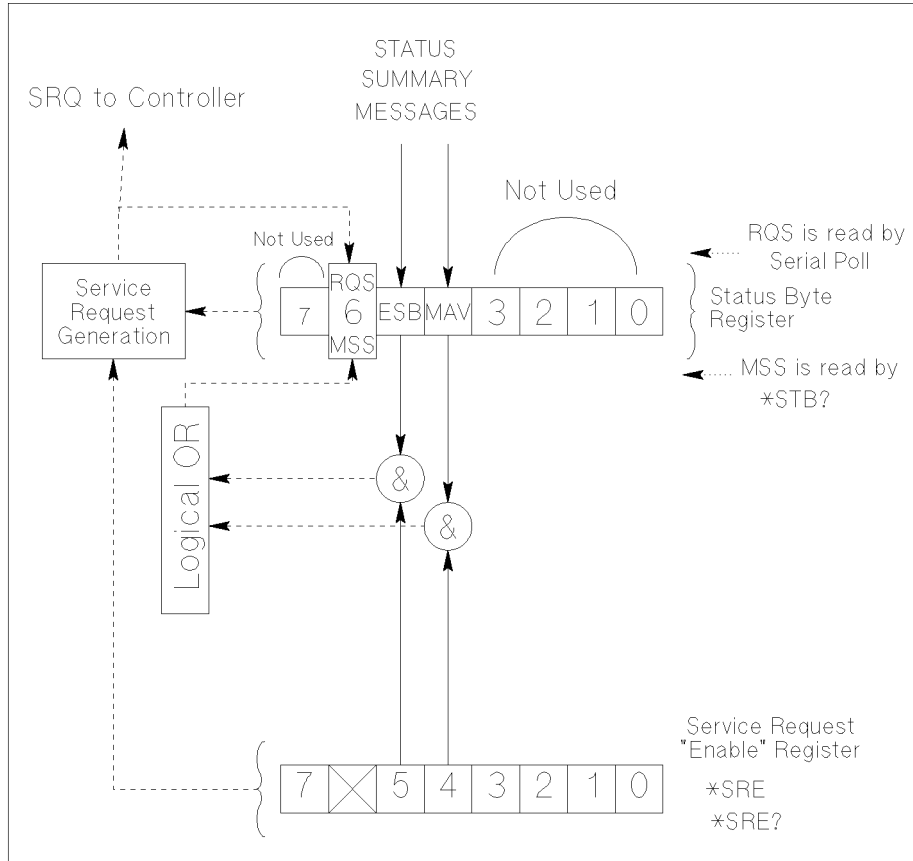

PG04003 120x120

Standard Event Status Register

The Standard Event Status Register has specific events assigned to specific bits. Refer to Figure 7-4 and Table 7-2.

Figure 7-4

Standard Event Status Register of E5250A

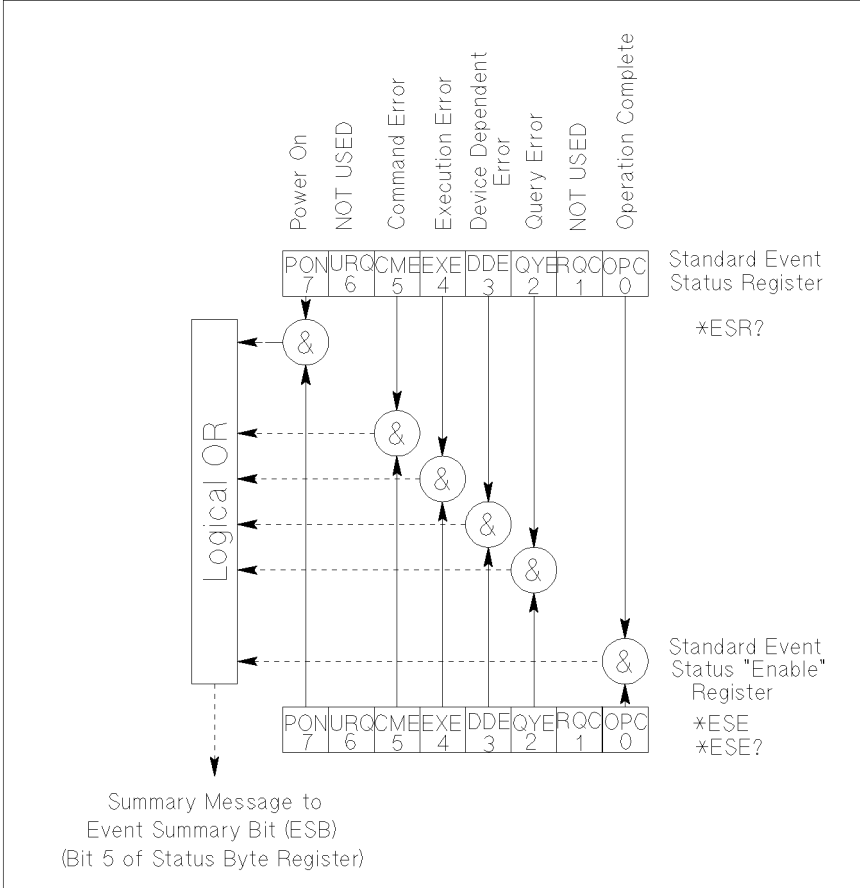

pg04004 100x100

Table 7-2

Standard Event Status Register of E5250A

Bit	Definition	Explanation
0	Operation Complete (OPC)	This event bit has meaning only if a request to monitor is set by the *OPC command. Refer to “*OPC” on page 7-9. This bit is set to 1 if there are no pending operations.
1	Not Used	Always 0.
2	Query Error (QYE)	<ul style="list-style-type: none"> An attempt is being made to read data from the Output Queue when no data is present or pending. Data in the Output Queue has been lost.
3	Device Dependent Error (DDE)	This event bit indicates that an error has occurred which is not a Command Error, a Query Error, or an Execution Error.
4	Execution Error (EXE)	Syntax of command is correct, but cannot be executed due to some condition of the E5250A.
5	Command Error (CME)	A command syntax error has been detected.
6	Not Used	Always 0.
7	Power On (PON)	This event bit indicates that an off-to-on transition has occurred in instrument's power supply.
8 to 15	Not used	Always 0.

Standard Event Status Enable Register

The Standard Event Status "Enable" Register is an 8-bit register that can be used by the programmer to select which bits of Standard Event Status Register are enabled. The status of the enabled bits are ORed together, and result of OR will be reported to the ESB bit (Bit5) of the Status Byte Register.

The 8 bits of this register correspond to the 8 bits of the Standard Event Status Register. Refer to Figure 7-4.

Output Queue

The Output Queue stores response messages until they are read. If an unread message exists, Bit4 (Message Available – MAV) of the Status Byte Register is set to 1. So, Bit4 is used to synchronize information exchange with the controller. Refer to Figure 7-5.

Figure 7-5

Output Queue of E5250A

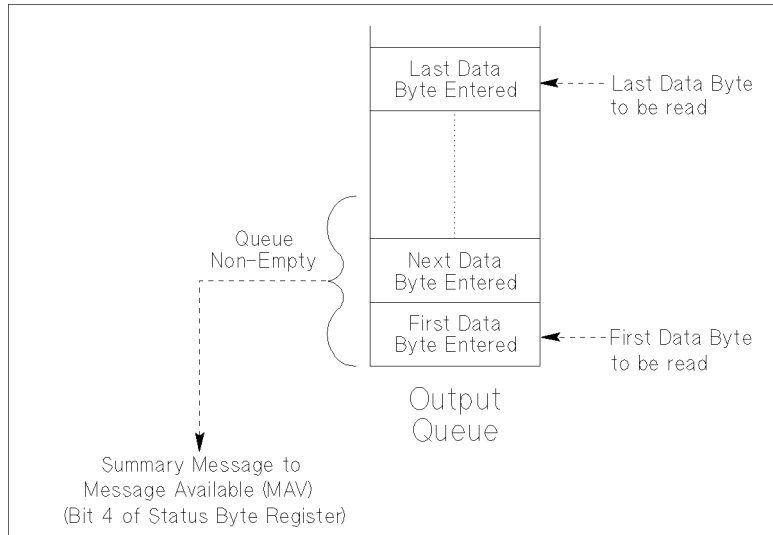

pg04005 120x100

The Response Formatter places Data Byte Messages and END messages into the Output Queue in response to query commands. These messages are removed from the Output Queue as they are read by the controller. As long as the Output Queue contains an unread message, MAV is 1.

Command Reference
Output Queue

8

VXI plug&play Driver

VXI plug&play Driver

This chapter introduces the VXI plug&play driver available for Agilent E5250A, and consists of the following sections:

- “System Requirements”
- “Installing VXIplug&play Driver”
- “Driver Functions”

System Requirements

The following system environments are required.

- Operating System
Microsoft Windows XP Professional, Windows 2000, Windows NT 4.0, Windows 98, or Windows 95. It must be supported by the application development environment and VISA I/O library.
- Application Development Environment (or programming environment)
Microsoft Visual Basic, Microsoft Visual C++, Borland C++Builder, National Instruments LabWindows or LabVIEW, or Agilent VEE. It must be supported by the VISA I/O library.
- GPIB (IEEE 488) Interface and 32-bit VISA I/O Library
Agilent GPIB interface with Agilent IO Libraries or equivalent.
- Computer and peripherals
Required specifications depend on the application development environment. See manual of the application development environment. The flexible disk drive is required to install the *VXIplug&play* driver. The CD-ROM drive is required to install the software needed to use driver.
- Minimum disk space
2 MB for 4155/4156 driver
1 MB for E5250A driver

Installing VXI*plug&play* Driver

The installation flow is shown below. If you have already installed the GPIB interface card, VISA I/O library, and programming software on your PC, skip steps 1 through 4.

1. Install the GPIB interface card into your PC.
See the interface card manual. Note the model number of the interface card, as you may need it to configure the interface (in step 3).
2. Install VISA I/O library.
Follow the instructions in the I/O library's setup program.
3. Configure and check the GPIB interface.
See the I/O library manual.
4. Install the programming software.
Follow the setup program instructions.
5. Install the VXI*plug&play* driver as shown below.
 - a. Insert the E5250A Plug&Play Driver Disk into the flexible disk drive connected to your PC.
 - b. Execute the SETUP.EXE program stored on the diskette. The program automatically installs the following files in \Vxipnp\Winnt\Hpe5250a or \Vxipnp\Win95\Hpe5250a depending on the OS.
 - hpe5250a.bas
 - hpe5250a.c
 - hpe5250a.def
 - hpe5250a.fp
 - hpe5250a.GID
 - hpe5250a.h
 - hpe5250a.hlp
 - readme.txt
 - DelsL1.isu

Driver Functions

Table 8-1 lists all the functions for the E5250A. You will see a brief description of the functions in the table.

For the description, syntax and parameters of the function, refer to the reference section following this table. The driver functions in the reference section will appear in the alphabetical order.

Table 8-1 E5250A Driver Function Lists

Category	Function	Description
Miscellaneous	hpe5250a_init	Initializes the E5250A.
	hpe5250a_close	Closes the connection with the E5250A.
	hpe5250a_reset	Executes the E5250A reset.
	hpe5250a_self_test	Executes the E5250A self-test.
	hpe5250a_error_query	Queries for the E5250A error code/message.
	hpe5250a_error_message	Queries for the driver error.
	hpe5250a_revision_query	Queries for the E5250A firmware/driver revisions.
	hpe5250a_timeOut	Sets the timeout.
	hpe5250a_timeOut_Q	Queries for the timeout setting.
	hpe5250a_errorQueryDetect	Sets the automatic error checking.
	hpe5250a_errorQueryDetect_Q	Queries for the automatic error checking setting.
	hpe5250a_dcl	Sends the Device Clear.
	hpe5250a_esr_Q	Queries for the ESR status.
	hpe5250a_readStatusByte_Q	Reads the E5250A status byte.
hpe5250a_opc_Q	Checks the E5250A operation completion status.	
Mode Control	hpe5250a_func	Sets the configuration mode.
	hpe5250a_connRuleSeq	Sets the connection rule/sequence.
Bias Mode	hpe5250a_biasPort	Selects the input bias port.
	hpe5250a_biasChanCard	Selects the card for bias mode.
	hpe5250a_biasChanList	Selects the channel list for bias mode.
	hpe5250a_biasState	Sets the bias port state.
	hpe5250a_biasChanList_Q	Queries for the bias channel list.
Couple Port	hpe5250a_couplePort	Selects the couple port.
	hpe5250a_coupleState	Sets the couple port state.

VXI plug&play Driver
Driver Functions

Category	Function	Description
Route Control	hpe5250a_closeList	Closes the channel list.
	hpe5250a_openList	Opens the channel list.
	hpe5250a_openCard	Opens all output on the card.
	hpe5250a_closeList_Q	Queries for the channel list status.
	hpe5250a_openList_Q	
	hpe5250a_closeCard_Q	Queries for the closed channel list on the card.
C/G Compensation	hpe5250a_CompenC	Executes the C/G compensation.
	hpe5250a_selectCompenFile	Selects the compensation data file.
Diagnostics	hpe5250a_testExec_Q	Executes the relay/front-panel/controller test.
	hpe5250a_testClear	Clears the test result.
Passthrough Functions	hpe5250a_cmd	Sends a command.
	hpe5250a_cmdInt	Sends a command with an integer parameter.
	hpe5250a_cmdReal	Sends a command with a real parameter.
	hpe5250a_cmdData_Q	Sends a command to read any data.
	hpe5250a_cmdString_Q	Sends a command to read string response.
	hpe5250a_cmdInt16_Q	Sends a command to read 16 bit integer response.
	hpe5250a_cmdInt16Arr_Q	Sends a command to read 16 bit integer array response.
	hpe5250a_cmdInt32_Q	Sends a command to read 32 bit integer response.
	hpe5250a_cmdInt32Arr_Q	Sends a command to read 32 bit integer array response.
	hpe5250a_cmdReal64_Q	Sends a command to read 64 bit real response.
hpe5250a_cmdReal64Arr_Q	Sends a command to read 64 bit real array response.	

hpe5250a_biasChanCard

This function will enable or disable bias on all the output ports of the specified card.

Syntax

```
ViStatus _VI_FUNC hpe5250a_biasChanCard(ViSession vi,
ViInt16 disable_enable, ViInt16 bias_cardno);
```

Parameters

vi	Instrument handle returned from hpe5250a_init().
disable_enable	Bias status. 0 : sets bias enabled card. 1 : sets bias disabled card.
bias_cardno	Card number. 1 (card 1), 2 (card 2), 3 (card 3), 4 (card 4), or 5 (all card) in the normal configuration mode, or 0 (all card in the automatic configuration mode). For the configuration mode, see hpe5250a_func.

hpe5250a_biasChanList

This function will enable or disable bias on all the output ports specified by the biaschan_list.

The parameter 'biaschan_list' is an array of integers with each integer representing one channel. The last number of the 'biaschan_list' should be "0" (numeric zero) to identify the end of the list. The maximum number of channels that can be specified by the list is 100.

Syntax

```
ViStatus _VI_FUNC hpe5250a_biasChanList(ViSession vi,
ViInt16 biaschan_disen, ViInt32 _VI_FAR biaschan_list[ ] );
```

Parameters

vi	Instrument handle returned from hpe5250a_init().
biaschan_disen	Bias status. 0 : sets bias enabled port. 1 : sets bias disabled port.
biaschan_list[]	Channel numbers. 5 digits integer. ABCDE. where A: card number, BC: input port number, DE: output port number. Top zero(s) can be ignored. For example, if A=0, BC=01, and DE=01, channel number should be 101 instead of 00101.

hpe5250a_biasChanList_Q

This function will query the instrument for the bias status for the channels given in the list.

The parameter 'biaschan_list' is an array of integers with each integer representing one channel. The last number of the 'biaschan_list' should be "0" (numeric zero) to identify the end of the list. The maximum number of channels that can be specified by the list is 100.

The 'bias_status' parameter is an array of integers containing the return values of the query. The 'bias_status' array returned will correspond one to one with 'biaschan_list' parameter.

Syntax

```
ViStatus _VI_FUNC hpe5250a_biasChanList_Q(ViSession vi, ViInt16 bias_disen,  
ViInt32 _VI_FAR biaschan_list[ ], ViInt32 _VI_FAR bias_status[ ] );
```

Parameters

vi	Instrument handle returned from hpe5250a_init().
bias_disen	Bias status for the query. 0 : confirms if the port is the bias enabled. 1 : confirms if the port is the bias disabled.
biaschan_list[]	Channel numbers to know the bias status. 5 digits integer. ABCDE. where A: card number, BC: input port number, DE: output port number. Top zero(s) can be ignored. For example, if A=0, BC=01, and DE=01, channel number should be 101 instead of 00101.
bias_status[]	Bias status of the channels given in the biaschan_list. Returned value depends on the setting of bias_disen as shown below: when bias_disen=0, 0 means bias disabled, 1 means enabled. when bias_disen=1, 0 means bias enabled, 1 means disabled.

hpe5250a_biasPort

This function will select which input port is the bias port on the specified card. For each card, you can specify the same or different Bias Port. This function applies only to the E5252A card.

Syntax ViStatus _VI_FUNC hpe5250a_biasPort(ViSession vi, ViInt16 biasport_cardno, ViInt16 bias_port);

Parameters

vi	Instrument handle returned from hpe5250a_init().
biasport_cardno	Card number. 1 (card 1), 2 (card 2), 3 (card 3), 4 (card 4), or 5 (all card) in the normal configuration mode, or 0 (all card in the automatic configuration mode). For the configuration mode, see hpe5250a_func.
bias_port	Input port number to be set to the bias port. 1 to 10 (input port 1 to input port 10).

hpe5250a_biasState

This function controls the bias mode for the specified card. When Bias Mode is ON, the input Bias Port is connected to all bias enabled output ports that are not connected to any other input ports. Bias disabled output ports are never connected to the input Bias Port when Bias Mode is ON.

Syntax ViStatus _VI_FUNC hpe5250a_biasState(ViSession vi, ViInt16 biasstate_cardno, ViInt16 state);

Parameters

vi	Instrument handle returned from hpe5250a_init().
biasstate_cardno	Card number. 1 (card 1), 2 (card 2), 3 (card 3), 4 (card 4), or 5 (all card) in the normal configuration mode, or 0 (all card in the automatic configuration mode). For the configuration mode, see hpe5250a_func.
state	Bias mode. 0 (OFF) or 1 (ON).

hpe5250a_close

This function terminates the software connection to the instrument and deallocates system resources. It is generally a good programming habit to close the instrument handle when the program is done using the instrument.

Syntax ViStatus _VI_FUNC hpe5250a_close(ViSession vi);

Parameters vi Instrument handle returned from hpe5250a_init().

hpe5250a_closeCard_Q

This function will query the card for the channels closed of the specified card.

The parameter 'closechan_list' contains the channel numbers returned by the instrument. This will be an array of integers terminated by 'zero' to identify the end of the list. Array of enough length should be passed to the function.

Syntax ViStatus _VI_FUNC hpe5250a_closeCard_Q(ViSession vi, ViInt16 close_card, ViInt32 _VI_FAR closechan_list[]);

Parameters vi Instrument handle returned from hpe5250a_init().

close_card Card number. 1 (card 1), 2 (card 2), 3 (card 3), or 4 (card 4) in the normal configuration mode, or 0 (all card in the automatic configuration mode). For the configuration mode, see hpe5250a_func.

closechan_list[] Channels closed of the specified card.

hpe5250a_closeList

This function will connect the input ports to the output ports specified by the channel list.

The parameter 'closechan_list' is an array of integers with each integer representing one channel. The last number of the 'closechan_list' should be "0" (numeric zero) to identify the end of the list. The maximum number of channels that can be specified by the list is 100.

Syntax

```
ViStatus _VI_FUNC hpe5250a_closeList(ViSession vi,  
ViInt32 _VI_FAR closechan_list[ ] );
```

Parameters

vi	Instrument handle returned from hpe5250a_init().
closechan_list[]	Channel numbers to connect. 5 digits integer. ABCDE. where A: card number, BC: input port number, DE: output port number. Top zero(s) can be ignored. For example, if A=0, BC=01, and DE=01, channel number should be 101 instead of 00101.

hpe5250a_closeList_Q

This function will query the instrument for the channels closed given in the 'closechan_list'.

The parameter 'closechan_list' is an array of integers with each integer representing one channel. The last number of the 'closechan_list' should be "0" (numeric zero) to identify the end of the list. The maximum number of channels that can be specified by the list is 100.

The 'close_status' parameter is an array of integers containing the return values of the query. The 'close_status' array returned will correspond one to one with 'closechan_list' parameter.

Syntax

```
ViStatus _VI_FUNC hpe5250a_closeList_Q(ViSession vi,  
ViInt32 _VI_FAR closechan_list[ ], ViInt32 _VI_FAR close_status[ ] );
```

Parameters

vi	Instrument handle returned from hpe5250a_init().
closechan_list[]	Channel numbers to know the close status. 5 digits integer. ABCDE. where A: card number, BC: input port number, DE: output port number. Top zero(s) can be ignored. For example, if A=0, BC=01, and DE=01, channel number should be 101 instead of 00101.
close_status[]	Status of the channels given in the closechan_list. 0 (opened) or 1 (closed).

hpe5250a_cmd

This function passes the cmd_str string to the instrument. Must be a NULL terminated C string.

Syntax

```
ViStatus _VI_FUNC hpe5250a_cmd(ViSession vi, ViString cmd_str);
```

Parameters

vi	Instrument handle returned from hpe5250a_init().
cmd_str	Instrument command (cannot exceed 256 bytes in length).

hpe5250a_cmdData_Q

This function passes the cmd_str string to the instrument. This entry point will wait for a response which may be any data. You specify the cmd_str and size parameters, and get result[].

Syntax ViStatus _VI_FUNC hpe5250a_cmdData_Q(ViSession vi, ViString cmd_str, ViInt32 size, ViChar _VI_FAR result[]);

Parameters

vi	Instrument handle returned from hpe5250a_init().
cmd_str	Instrument command (cannot exceed 256 bytes in length).
size	Length of result in bytes. 2 to 32767.
result[]	Response from instrument.

hpe5250a_cmdInt

This function passes the cmd_str string to the instrument. This entry point passes the string in cmd_str followed by a space and then the integer in value. Note that either an Int16 or 32 can be passed as the Int16 will be promoted.

Syntax ViStatus _VI_FUNC hpe5250a_cmdInt(ViSession vi, ViString cmd_str, ViInt32 value);

Parameters

vi	Instrument handle returned from hpe5250a_init().
cmd_str	Instrument command (cannot exceed 256 bytes in length).
value	Parameter for command. -2147483647 to 2147483647.

hpe5250a_cmdInt16Arr_Q

This function passes the `cmd_str` string to the instrument. This command expects a response that is a definite arbitrary block of 16 bit integers. You specify the `cmd_str` and `size` parameters, and get `result[]` and `count`.

Syntax `ViStatus _VI_FUNC hpe5250a_cmdInt16Arr_Q(ViSession vi, ViString cmd_str, ViInt32 size, ViInt16 _VI_FAR result[], ViPInt32 count);`

Parameters

vi	Instrument handle returned from <code>hpe5250a_init()</code> .
cmd_str	Instrument command (cannot exceed 256 bytes in length).
size	Size of <code>result[]</code> (number of items in the array). 1 to 2147483647.
result[]	Response from instrument.
count	Count of valid items in <code>result[]</code> .

hpe5250a_cmdInt16_Q

This function passes the `cmd_str` string to the instrument. This command expects a response that can be returned as a 16 bit integer.

Syntax `ViStatus _VI_FUNC hpe5250a_cmdInt16_Q(ViSession vi, ViString cmd_str, ViPInt16 result);`

Parameters

vi	Instrument handle returned from <code>hpe5250a_init()</code> .
cmd_str	Instrument command (cannot exceed 256 bytes in length).
result	Response from instrument.

hpe5250a_cmdInt32Arr_Q

This function passes the cmd_str string to the instrument. This command expects a response that is a definite arbitrary block of 32 bit integers. You specify the cmd_str and size parameters, and get result[] and count.

Syntax ViStatus_VI_FUNC hpe5250a_cmdInt32Arr_Q(ViSession vi, ViString cmd_str, ViInt32 size, ViInt32_VI_FAR result[], ViPInt32 count);

Parameters

vi	Instrument handle returned from hpe5250a_init().
cmd_str	Instrument command (cannot exceed 256 bytes in length).
size	Size of result[] (number of items in the array). 1 to 2147483647.
result[]	Response from instrument.
count	Count of valid items in result[].

hpe5250a_cmdInt32_Q

This function passes the cmd_str string to the instrument. This command expects a response that can be returned as a 32 bit integer.

Syntax ViStatus_VI_FUNC hpe5250a_cmdInt32_Q(ViSession vi, ViString cmd_str, ViPInt32 result);

Parameters

vi	Instrument handle returned from hpe5250a_init().
cmd_str	Instrument command (cannot exceed 256 bytes in length).
result	Response from instrument.

hpe5250a_cmdReal

This function passes the cmd_str string to the instrument. This entry point passes the string in cmd_str followed by a space and then the real in value. Note that either an Real32 or 64 can be passed as the Real32 will be promoted.

Syntax ViStatus _VI_FUNC hpe5250a_cmdReal(ViSession vi, ViString cmd_str, ViReal64 value);

Parameters

vi	Instrument handle returned from hpe5250a_init().
cmd_str	Instrument command (cannot exceed 256 bytes in length).
value	Parameter for command. -1E+300 to 1E+300.

hpe5250a_cmdReal64Arr_Q

This function passes the cmd_str string to the instrument. This command expects a response that is a definite arbitrary block of 64 bit reals. You specify the cmd_str and size parameters, and get result[] and count.

Syntax ViStatus _VI_FUNC hpe5250a_cmdReal64Arr_Q(ViSession vi, ViString cmd_str, ViInt32 size, ViReal64 _VI_FAR result[], ViPInt32 count);

Parameters

vi	Instrument handle returned from hpe5250a_init().
cmd_str	Instrument command (cannot exceed 256 bytes in length).
size	Size of result[] (number of items in the array). 1 to 2147483647.
result[]	Response from instrument.
count	Count of valid items in result[].

hpe5250a_cmdReal64_Q

This function passes the cmd_str string to the instrument. This command expects a response that can be returned as a 64 bit real.

Syntax ViStatus _VI_FUNC hpe5250a_cmdReal64_Q(ViSession vi, ViString cmd_str, ViPReal64 result);

Parameters

vi	Instrument handle returned from hpe5250a_init().
cmd_str	Instrument command (cannot exceed 256 bytes in length).
result	Response from instrument.

hpe5250a_cmdString_Q

This function passes the cmd_str string to the instrument. This entry point will wait for a response which must be a string (character data). You specify the cmd_str and size parameters, and get result[].

Syntax ViStatus _VI_FUNC hpe5250a_cmdString_Q(ViSession vi, ViString cmd_str, ViInt32 size, ViChar _VI_FAR result[]);

Parameters

vi	Instrument handle returned from hpe5250a_init().
cmd_str	Instrument command (cannot exceed 256 bytes in length).
size	Length of result in bytes. 2 to 32767.
result[]	Response from instrument.

hpe5250a_compenC

This function compensates capacitance/conductance data measured by using Agilent 4284A C meter, and returns compensation results. If you change the compensation data, create the compensation data file, and specify the data file using hpe5250a_selectCompenFile function before executing this function.

Syntax

```
ViStatus _VI_FUNC hpe5250a_compenC(ViSession vi, ViReal64 frequency,  
ViReal64 len_hptrx, ViReal64 len_usrtrx_h, ViReal64 len_usrtrx_l,  
ViReal64 len_usrcoax_h, ViReal64 len_usrcoax_l, ViReal64 raw_c,  
ViReal64 raw_g, ViPReal64 compen_c, ViPReal64 compen_g);
```

Parameters

vi	Instrument handle returned from hpe5250a_init().
frequency	Measurement frequency. 1E3 to 1E6 Hz.
len_hptrx	Agilent 16494A triaxial cable. 1.5 or 3.0 m.
len_usrtrx_h	Triaxial cable length (in m) between connector plate and DUT high terminal. If you do not use triaxial cable, enter 0 (zero).
len_usrtrx_l	Triaxial cable length (in m) between connector plate and DUT low terminal. If you do not use triaxial cable, enter 0 (zero).
len_usrcoax_h	Coaxial cable length (in m) between connector plate and DUT high terminal. If you do not use coaxial cable, enter 0 (zero).
len_usrcoax_l	Coaxial cable length (in m) between connector plate and DUT low terminal. If you do not use coaxial cable, enter 0 (zero).
raw_c	Capacitance value (in F) measured by the 4284A.
raw_g	Conductance value (in S) measured by the 4284A.
compen_c	Capacitance compensation result (in F).
compen_g	Conductance compensation result (in S).

hpe5250a_connRuleSeq

The function sets connection rule and connection sequence for the specified card.

Syntax

```
ViStatus _VI_FUNC hpe5250a_connRuleSeq(ViSession vi,  
ViInt16 cardno_ruleseq, ViInt16 rule, ViInt16 sequence);
```

Parameters

vi	Instrument handle returned from hpe5250a_init().
cardno_ruleseq	Card number. 1 (card 1), 2 (card 2), 3 (card 3), 4 (card 4), or 5 (all card) in the normal configuration mode, or 0 (all card in the automatic configuration mode). For the configuration mode, see hpe5250a_func.
rule	Connection rule. 0 (free route) or 1 (single route).
sequence	Connection sequence. 0, 1, or 2. See below. 0 (no sequence) 1 (break before make) 2 (make before break)

hpe5250a_couplePort

This function sets the couple ports which are used for making kelvin connections on the specified card. The specified input port number will be coupled with the next input port and two output ports. For each card, you may setup the same or different couple ports. This command overwrites the previous couple port setting for the card. This command applies only to the E5252A card.

The couple port mode is controlled by the hpe5250a_coupleState function.

Syntax

```
ViStatus _VI_FUNC hpe5250a_couplePort(ViSession vi,  
ViInt16 coupleport_cardno, ViInt16 port1, ViInt16 port3, ViInt16 port5,  
ViInt16 port7, ViInt16 port9);
```

Parameters

vi	Instrument handle returned from hpe5250a_init().
coupleport_cardno	Card number. 1 (card 1), 2 (card 2), 3 (card 3), 4 (card 4), or 5 (all card) in the normal configuration mode, or 0 (all card in the automatic configuration mode). For the configuration mode, see hpe5250a_func.
port1	Couple port by the input ports 1 and 2. 0 (disable) or 1 (enable).
port3	Couple port by the input ports 3 and 4. 0 (disable) or 1 (enable).
port5	Couple port by the input ports 5 and 6. 0 (disable) or 1 (enable).
port7	Couple port by the input ports 7 and 8. 0 (disable) or 1 (enable).
port9	Couple port by the input ports 9 and 10. 0 (disable) or 1 (enable).

hpe5250a_coupleState

This function controls the couple port mode for the specified card. This function applies only to the E5252A card.

Syntax ViStatus _VI_FUNC hpe5250a_coupleState(ViSession vi,
ViInt16 couplestate_cardno, ViInt16 couple_state);

Parameters

vi	Instrument handle returned from hpe5250a_init().
couplestate_cardno	
o	Card number. 1 (card 1), 2 (card 2), 3 (card 3), 4 (card 4), or 5 (all card) in the normal configuration mode, or 0 (all card in the automatic configuration mode). For the configuration mode, see hpe5250a_func.
couple_state	Couple port mode. 0 (OFF) or 1 (ON).

hpe5250a_dcl

This function sends a device clear (DCL) to the instrument.

A device clear will abort the present operation and enable the instrument to accept a new command or query.

This is particularly useful in situations where it is not possible to determine the instrument state. In this case, it is customary to send a device clear before issuing a new instrument driver function. The device clear ensures that the instrument will be able to begin processing the new commands.

Syntax ViStatus _VI_FUNC hpe5250a_dcl(ViSession vi);

Parameters

vi	Instrument handle returned from hpe5250a_init().
-----------	---

hpe5250a_error_message

This function translates the error return value from an instrument driver function to a readable string.

Syntax

```
ViStatus _VI_FUNC hpe5250a_error_message(ViSession vi, ViStatus  
error_number, ViChar _VI_FAR message[ ] );
```

Parameters

vi Instrument handle returned from hpe5250a_init().
error_number Error return value from the driver function.
message[] Error message string. This is limited to 256 characters.

hpe5250a_error_query

This function returns the error numbers and corresponding error messages in the error queue of a instrument. See Chapter 11 for a listing of the instrument error numbers and messages.

Instrument errors may occur when you places the instrument in a bad state such as sending an invalid sequence of coupled commands. Instrument errors can be detected by polling. Automatic polling can be accomplished by using the hpe5250a_errorQueryDetect function.

Syntax

```
ViStatus _VI_FUNC hpe5250a_error_query(ViSession vi, ViPInt32 error_number,  
ViChar _VI_FAR error_message[ ] );
```

Parameters

vi Instrument handle returned from hpe5250a_init().
error_number Instrument's error code.
error_message[] Instrument's error message. This is limited to 256 characters.

hpe5250a_errorQueryDetect

This function enables or disables automatic instrument error checking.

If automatic error checking is enabled then the driver will query the instrument for an error at the end of each function call.

Syntax ViStatus _VI_FUNC hpe5250a_errorQueryDetect(ViSession vi,
ViBoolean errorQueryDetect);

Parameters **vi** Instrument handle returned from hpe5250a_init().
errorQueryDetect Error checking enable (VI_TRUE) or disable (VI_FALSE).

hpe5250a_errorQueryDetect_Q

This function indicates if automatic instrument error detection is enabled or disabled.

Syntax ViStatus _VI_FUNC hpe5250a_errorQueryDetect_Q(ViSession vi,
ViPBoolean pErrDetect);

Parameters **vi** Instrument handle returned from hpe5250a_init().
pErrDetect Error checking enable (VI_TRUE) or disable (VI_FALSE).

hpe5250a_esr_Q

This function returns the contents of the ESR register. The driver returns the equivalent messages (see Parameters).

Syntax

```
ViStatus _VI_FUNC hpe5250a_esr_Q(ViSession vi, ViChar _VI_FAR errstr[ ] );
```

Parameters

vi Instrument handle returned from hpe5250a_init().

errstr[] Response from instrument.

Bit Value	Message
1	“ESR_OPC”
2	“ESR_RQL”
4	“ESR_QYE_ERROR”
8	“ESR_DEVICE_DEPENDENT_ERROR”
16	“ESR_EXECUTION_ERROR”
32	“ESR_COMMAND_ERROR”
64	“ESR_URQ”
128	“ESR_PON”
OTHERS	“ESR_MULTI_EVENT”

hpe5250a_func

This function is used to set the channel configuration to the auto configuration mode or the normal configuration mode.

Syntax

```
ViStatus _VI_FUNC hpe5250a_func(ViSession vi, ViInt16 channel_config);
```

Parameters

vi Instrument handle returned from hpe5250a_init().

channel_config Configuration mode. 0 (auto) or 1 (normal).

hpe5250a_init

This function initializes the software connection to the instrument and optionally verifies that instrument is in the system. In addition, it may perform any necessary actions to place the instrument in its reset state.

If the hpe5250a_init function encounters an error, then the value of the vi output parameter will be VI_NULL.

Syntax ViStatus _VI_FUNC hpe5250a_init(ViRsrc InstrDesc, ViBoolean id_query, ViBoolean do_reset, ViPSession vi);

Parameters

InstrDesc	Instrument description. Examples; GPIB0::1::INSTR.
id_query	VI_TRUE (to perform In-System Verification), or VI_FALSE (do not perform In-System Verification).
do_reset	VI_TRUE (to perform reset operation), or VI_FALSE (do not perform reset operation).
vi	Instrument handle. This is VI_NULL if an error occurred during the init.

hpe5250a_opc_Q

This function does the *OPC? common command.

Syntax ViStatus _VI_FUNC hpe5250a_opc_Q(ViSession vi, ViPBoolean result);

Parameters

vi	Instrument handle returned from hpe5250a_init().
result	VI_TRUE (Operation complete), or VI_FALSE (Operation is pending).

hpe5250a_openCard

This function will disconnect all input ports from all output ports for the specified card. Then if bias mode is ON, connects the input bias port to all bias enabled output ports.

Syntax ViStatus _VI_FUNC hpe5250a_openCard(ViSession vi, ViInt16 open_cardno);

Parameters

vi	Instrument handle returned from hpe5250a_init().
open_cardno	Card number. 1 (card 1), 2 (card 2), 3 (card 3), 4 (card 4), or 5 (all card) in the normal configuration mode, or 0 (all card in the automatic configuration mode). For the configuration mode, see hpe5250a_func.

hpe5250a_openList

This function will disconnect the input ports from the output ports specified by the channel list.

The parameter 'openchan_list' is an array of integers with each integer representing one channel. The last number of the 'openchan_list' should be "0" (numeric zero) to identify the end of the list. The maximum number of channels that can be specified by the list is 100.

Syntax ViStatus _VI_FUNC hpe5250a_openList(ViSession vi,
ViInt32_VI_FAR openchan_list[]);

Parameters

vi	Instrument handle returned from hpe5250a_init().
openchan_list[]	Channel numbers to disconnect. 5 digits integer. ABCDE. where A: card number, BC: input port number, DE: output port number. Top zero(s) can be ignored. For example, if A=0, BC=01, and DE=01, channel number should be 101 instead of 00101.

hpe5250a_openList_Q

This function will query the instrument for the channels open given in the 'openchan_list'.

The parameter 'openchan_list' is an array of integers with each integer representing one channel. The last number of the 'openchan_list' should be "0" (numeric zero) to identify the end of the list. The maximum number of channels that can be specified by the list is 100.

The 'open_status' parameter is an array of integers containing the return values of the query. The 'open_status' array returned will correspond one to one with 'openchan_list' parameter.

Syntax

```
ViStatus_VI_FUNC hpe5250a_openList_Q(ViSession vi,
ViInt32_VI_FAR openchan_list[ ], ViInt32_VI_FAR open_status[ ]);
```

Parameters

vi	Instrument handle returned from hpe5250a_init().
openchan_list[]	Channel numbers to know the open status. 5 digits integer. ABCDE. where A: card number, BC: input port number, DE: output port number. Top zero(s) can be ignored. For example, if A=0, BC=01, and DE=01, channel number should be 101 instead of 00101.
open_status[]	Status of the channels given in the openchan_list. 1 (opened) or 0 (closed).

hpe5250a_readStatusByte_Q

This function returns the contents of the status byte register.

Syntax

```
ViStatus_VI_FUNC hpe5250a_readStatusByte_Q(ViSession vi,
ViPInt16 statusByte);
```

Parameters

vi	Instrument handle returned from hpe5250a_init().
statusByte	The contents of the status byte are returned in this parameter.

hpe5250a_reset

This function places the instrument in a default state. Before issuing this function, it may be necessary to send a device clear to ensure that the instrument can execute a reset. A device clear can be issued by invoking hpe5250a_dcl function.

Syntax ViStatus _VI_FUNC hpe5250a_reset(ViSession vi);

Parameters vi Instrument handle returned from hpe5250a_init().

hpe5250a_revision_query

This function returns the driver revision and the instrument firmware revision.

Syntax ViStatus _VI_FUNC hpe5250a_revision_query(ViSession vi,
ViChar_VI_FAR driver_rev[], ViChar_VI_FAR instr_rev[]);

Parameters vi Instrument handle returned from hpe5250a_init().
driver_rev[] Instrument driver revision. This is limited to 256 characters.
instr_rev[] Instrument firmware revision. This is limited to 256 characters.

hpe5250a_selectCompenFile

This function specifies capacitance/conductance compensation data file used to compensate C/G by using hpe5250a_compenC.

Syntax

```
ViStatus _VI_FUNC hpe5250a_selectCompenFile(ViSession vi,
ViString file_name);
```

Parameters

vi Instrument handle returned from hpe5250a_init().

file_name Compensation data file name. Use absolute path. If the value is NULL string, the default data is used.

Remarks

If you change the compensation data, copy the default data shown below, and modify the data for your measurement cable. You will need to change the data for DATA05 and 06, and/or DATA07 and 08 corresponding to your cables. To measure and change the compensation data, refer to Chapter 6. To get the R, L, and C value, measure R, L, and C of the cable using the 4284A, and divide them by cable length (in m). Compensation data must be the value for 1 m length. Do not change the data format in the file.

```
# E5250A C Compensation coefficient data table
#
# CAUTION : Do not add or delete "REVISION" line and "DATAxx" line.
#           Change the value for R,L,C of DATA05,06,07 or 08.
#
REVISION      A. 03. 00
#             R [ohm]      L [H]      C [F]
DATA00        74. 65E-3     140. 00E-9    58. 44E-12   # Frame Path 1
DATA01        75. 41E-3     90. 00E-9     67. 13E-12   # Frame Path 2
DATA02        231. 41E-3    450. 00E-9    178. 85E-12  # Card Path High
DATA03        177. 56E-3    390. 00E-9    135. 45E-12  # Card Path Low
DATA04        100. 70E-3    400. 00E-9     80. 00E-12   # Triax Cable    [/m]
DATA05        100. 70E-3    400. 00E-9     80. 00E-12   # User Triax Cbl H [/m]
DATA06        100. 70E-3    400. 00E-9     80. 00E-12   # User Triax Cbl L [/m]
DATA07        114. 00E-3    544. 00E-9    130. 00E-12  # User Coax Cbl H [/m]
DATA08        114. 00E-3    544. 00E-9    130. 00E-12  # User Coax Cbl L [/m]
DATA09        0. 00E-3      0. 00E-9      1. 20E-12    # Stray Capacitance
# END of Data
```

hpe5250a_self_test

This function causes the instrument to perform a self-test and returns the result of that self-test. This is used to verify that an instrument is operating properly. A failure may indicate a potential hardware problem.

Syntax

```
ViStatus _VI_FUNC hpe5250a_self_test(ViSession vi, ViPInt16 test_result,  
ViChar _VI_FAR test_message[ ] );
```

Parameters

vi Instrument handle returned from hpe5250a_init().

test_result Numeric result from self-test operation. 0: No error.

test_message[] Self-test status message. This is limited to 256 characters.

hpe5250a_testClear

This function clears the test result for the specified relay card or the front panel or the controller.

Syntax

```
ViStatus _VI_FUNC hpe5250a_testClear(ViSession vi, ViInt16 framecard_clear);
```

Parameters

vi Instrument handle returned from hpe5250a_init().

framecard_clear Test result to be cleared. 0, 1, 2, 3, 4, 5, 6, or 7. See below.

- 0 (test result of all test)
- 1 (card 1 relay test result)
- 2 (card 2 relay test result)
- 3 (card 3 relay test result)
- 4 (card 4 relay test result)
- 5 (relay test result of all card)
- 6 (front panel test result)
- 7 (controller test result)

hpe5250a_testExec_Q

This function executes the controller test, the front panel test, or the relay test for the specified card. You must attach the relay test adapter before executing the relay test. The Front Panel test requires the key to be pressed within 10 seconds else the test will fail.

Syntax	<code>ViStatus_VI_FUNC hpe5250a_testExec_Q(ViSession vi, ViInt16 framecard_exec, ViPInt16 exec_result);</code>
Parameters	<p>vi Instrument handle returned from <code>hpe5250a_init()</code>.</p> <p>framecard_exec Test to be executed. 1 (card 1 relay test) to 4 (card 4 relay test), 5 (relay test for all card), 6 (front panel test), or 7 (controller test).</p> <p>exec_result Test result. 0: No error.</p>

hpe5250a_timeOut

This function sets a minimum timeout value for driver I/O transactions in milliseconds. The default timeout period is 2 seconds.

Syntax	<code>ViStatus_VI_FUNC hpe5250a_timeOut(ViSession vi, ViInt32 timeOut);</code>
Parameters	<p>vi Instrument handle returned from <code>hpe5250a_init()</code>.</p> <p>timeOut I/O timeout value for all functions in the driver. in milliseconds. 0 to 2147483647.</p>

hpe5250a_timeOut_Q

This function returns the timeout value for driver I/O transactions in milliseconds.

Syntax	<code>ViStatus_VI_FUNC hpe5250a_timeOut_Q(ViSession vi, ViPInt32 pTimeOut);</code>
Parameters	<p>vi Instrument handle returned from <code>hpe5250a_init()</code>.</p> <p>pTimeOut Minimum timeout period that the driver can be set to, in milliseconds.</p>

VXI plug&play Driver
Driver Functions

9 **Executing Sample Programs**

Executing Sample Programs

This chapter explains how to use the following sample programs:

- “Vth and Capacitance Measurement Program”
- “HCI Measurement Program”

The sample programs are saved in the E5250A Program Disk (LIF formatted, 3.5-inch diskette) that is furnished with Agilent E5250A. This disk includes the setup files for controlling Agilent 4155/4156 Semiconductor Parameter Analyzer used in the program with Agilent E5250A.

NOTE

The sample programs are HP BASIC language programs, so you need an HP BASIC workstation to execute the programs.

The Vth and Capacitance Measurement Program uses the Agilent 4155/4156, Agilent 4284A Precision LCR Meter, and the E5250A with the E5252A card.

The HCI Measurement Program uses the 4155/4156, Bias Sources, and the E5250A with the E5255A cards.

CAUTION

These are sample programs, so you may need to modify these programs and the 4155/4156 setup files for your application before executing the programs.

If the sample programs damage your device, Agilent Technologies is *NOT LIABLE* for the damage.

NOTE**To Keep Original Program Disk**

Copy the E5250A Program Disk, and keep the original disk for your backup. Also, for storing a program after you modify it, use a file name that is different from the original program name.

Vth and Capacitance Measurement Program

This section introduces and explains how to use and modify the Vth and Capacitance measurement program. This section consists of the following sections:

- “Introduction”
- “Setting up the Measurement Environment”
- “Executing the Program”
- “Modifying the Program”

Introduction

This program measures the parameters of the devices shown in Table 9-1 by using the Agilent 4155/4156 Semiconductor Parameter Analyzer, the Agilent 4284A Precision LCR Meter, and the Agilent E5250A with the E5252A card.

The program flow is shown in Table 9-2. In this program, the 4155/4156 is set up by loading the 4155/4156 setup file E5252.MES, which is saved on the E5250A Program Disk. So, the program disk must be in the 4155/4156's disk drive when you execute the program.

Table 9-1

Devices and Parameters Measured

Device	No. of Devices Measured	Measurement Parameter	Instrument Used
N-channel MOSFET	1	Threshold Voltage (Vth)	4155/4156
Capacitor	1	Capacitance	4284A

Executing Sample Programs
Vth and Capacitance Measurement Program

Table 9-2

Vth and Capacitance Measurement Flow

Step	Description
1	Initializes the Instruments: <ol style="list-style-type: none"> 1. Resets the 4155/4156. 2. Resets the 4284A. 3. Resets and initializes the E5250A. Configuration Mode: NORMAL Bias Mode: OFF Connection Rule: Single Connection Sequence: BBM
2	Measures Vth of MOSFET: <ol style="list-style-type: none"> 1. Loads the 4155/4156 setup file for Vth measurement. And sets up the 4155/4156 measurement conditions. 2. Creates connection channels in the E5250A for Vth measurement. 3. Measures Vth of MOSFET. 4. Disconnects the connection channels in the E5250A. 5. Judges pass or fail. 6. Displays result and measurement data on computer's screen. 7. Resets instrument.
3	Measures Capacitance: <ol style="list-style-type: none"> 1. Sets up the 4284A measurement conditions. 2. Creates connection channels in the E5250A for C measurement. 3. Measures capacitance. 4. Disconnects the connection channels in the E5250A. 5. Compensates the measurement data. 6. Judges pass or fail. 7. Displays result and measurement data on computer's screen. 8. Resets instrument.
4	Resets all instruments.

Vth Measurement Setup

Measurement setup of the E5250A and 4155/4156 for this program is as follows:

- E5250A/E5252A Setup:

Slot No	Channels
1	10101, 10202, 10303, and 10404
2	not used.
3	not used.
4	not used.

- 4155/4156 Setup:

Below is summary of measurement setup saved in E5252.MES file. For details of the setup data, GET the E5252.MES file using the 4155/4156 and refer to the setup displayed on the 4155/4156 screen.

Channel/Source Setup:

SMU	VNAME	I NAME	MODE	FUNCTION	Source Setup
SMU1	Vd	Id	V	CONST	5V
SMU2	Vg	Ig	V	VAR1	0 to 5V, 50mV step
SMU3	Vs	Is	COMMON	CONST	Common
SMU4	Vsb	Isb	V	CONST	0V

User Function Setup:

NAME	UNIT	DEFINITION
SQRTId		SQRT (Id)
GRAD		DIFF (SQRTId, Vg)
VTH	V	@L1X
BETA		@L1G^2

Executing Sample Programs
Vth and Capacitance Measurement Program

Display Setup:

	Xaxis	Y1axis	Y2axis
NAME	Vg	SQRTId	GRAD
SCALE	LINEAR	LINEAR	LINEAR
MIN	0 V	0	0
MAX	5 V	200 m	80 m

Also the DATA VARIABLES fields set VTH and BETA.

Auto Analysis Setup:

```
*LINE1: [ TANGENT ] line on [ Y1 ] at a point where
[ GRAD ] = [ MAX(GRAD) ]
```

```
-----
*LINE2: [ ]
```

```
-----
*MARKER: At a point where
[ GRAD ] = [ MAX(GRAD) ]
[ ]
```

```
-----
*Interpolate: [OFF]
```

Capacitance Measurement Setup

Measurement setup of the E5250A and 4284A for this program is as follows:

- E5250A/E5252A Setup:

Slot No	Channels
1	10905 and 11006
2	not used.
3	not used.
4	not used.

- 4284A Setup:

Measurement Frequency	100 kHz
Signal Level	0.03 V
Measurement Function	Cp-G

Setting up the Measurement Environment

Before executing the program, you need to set up the measurement environment. Table 9-3 lists the required equipment.

Connect the E5250A output to Device Under Test (DUT). For details, refer to “Setting up Measurement Environment” on page 4-1.

And connect all equipment as shown in Figure 9-1 and Table 9-4. The E5252A must be installed in slot1 of the E5250A.

Table 9-3

Required Equipments

Agilent Model/Part No.	Description	Qty.
E5250A	Low Leakage Switch Mainframe	1
E5252A	10×12 Matrix Switch	1
4155/4156	Semiconductor Parameter Analyzer	1
16494A-003	Triaxial Cable (80 cm)	4
16494A-001 or -002	Triaxial Cable (1.5 m or 3 m)	6
16495F	Connector Plate	1
4284A with 4284A-006	Precision LCR Meter	1
16048D/E	Test Lead	1
1250-2405	BNC T-type Adapter	2
10833A/B/C	GPIB Cable	3

Executing Sample Programs
Vth and Capacitance Measurement Program

Figure 9-1 Vth and C Measurement Setup and DUT Connection

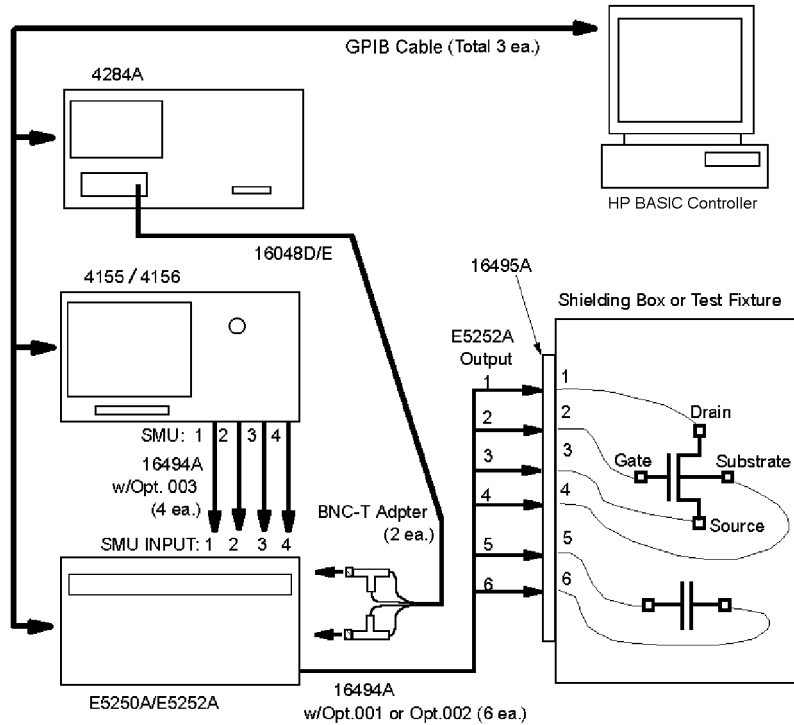

Table 9-4 Instrument and DUT Connection

Instrument		E5250A		DUT Terminal (via Connector Plate)
Model No.	Measurement Port	Input Port	Output Port	
4155/4156	SMU 1	SMU INPUT 1	OUTPUT 1	MOSFET Drain
	SMU 2	SMU INPUT 2	OUTPUT 2	MOSFET Gate
	SMU 3	SMU INPUT 3	OUTPUT 3	MOSFET Source
	SMU 4	SMU INPUT 4	OUTPUT 4	MOSFET Substrate
4284A	Hp, Hc	AUX INPUT CV1	OUTPUT 5	Capacitance (H)
	Lp, Lc	AUX INPUT CV2	OUTPUT 6	Capacitance (L)

Executing the Program

Before executing the program, do the following:

1. Set the GPIB address for each instrument as follows:
 - 4155/4156: 717
 - 4284A: 724
 - E5250A: 722
2. Turn on all instruments and the computer.
3. Boot up HP BASIC operating system.
4. Set the 4155/4156 to "NOT SYSTEM CONTROLLER" on the SYSTEM: MISCELLANEOUS page.
5. Insert the program disk into the disk drive that is connected to the computer.
6. Specify the mass storage device where the program disk is inserted by using the MSI statement.

For example, if the device is ":CS80,702,1", enter the following command:

```
MSI ":CS80,702,1"
```

7. GET the Vth and C measurement program (SP_MAT), and RE-STORE the program. In following example, the file is stored as program file P_MAT.

```
GET "SP_MAT"  
RE-STORE "P_MAT"
```
8. GET the Capacitance Compensation Routine (C_COMPEN), and RE-STORE the program. In following example, the file is stored as program file C_COM.

```
GET "C_COMPEN"  
RE-STORE "C_COM"
```

For details of Capacitance Compensation Routine, refer to "Using the Capacitance Compensation Routine" on page 6-28.

Executing Sample Programs

Vth and Capacitance Measurement Program

Execute the program as follows:

1. LOAD the Vth and C measurement program as following example.

```
LOAD "P_MAT"
```
2. Link the Capacitance Compensation Routine by using the LOADSUB ALL statement as in following example.

```
LOADSUB ALL FROM "C_COM"
```
3. Eject the E5250A Program Disk from the disk drive connected to the computer.
4. Insert the E5250A Program Disk into the 4155/4156's disk drive. Setup file E5252.MES is stored on the disk and is used to set up 4155/4156 for the Vth measurement.
5. RUN the program.
6. After the measurement, measurement results are displayed on the computer as shown in example in Figure 9-2.

Figure 9-2

Example of Vth and C Measurement Results

```
Comment : Vth & C Meas. Sample Program
Test Time : 30 Sep 1995 10:29:27
# P/F Min. Meas. Max. Comment
1 P 10.000E-002 18.255E-001 20.000E-001 MOSFET Vth Measurement
2 F 8.000E-12 2.164E-11 2.000E-11 Capacitance Measurement
```

Modifying the Program

This section explains how to modify the sample program:

- “To change the GPIB Address”
- “To change the header of the measurement result report”
- “To output the measurement report to printer”
- “To execute the 4155/4156 calibration”
- “To save the 4155/4156 measurement data”
- “To change the Vth measurement setup”
- “To change the capacitance measurement setup”
- “To use the VFP data upload library”

To change the GPIB Address

You can EDIT the program to change the following parameters in the `Init_setting` subprogram.

Parameter	Description	Default
Hpib_sc	GPIB select code	7
Ad415x	GPIB address for the 4155/4156	17
Ad4284	GPIB address for the 4284A	24
Ad5250	GPIB address for the E5250A	22

To change the header of the measurement result report

You can EDIT to change the following parameters in the `Init_setting` subprogram. This is for header of report displayed on the computer. For the display example, refer to Figure 9-2.

Parameter	Description	Default
Usercomm\$	Header comment (title) of the report.	"Vth C Meas. Sample Program"
Test_num	Initial number for numbering the test item. If value is 0, the first test item will be number 1.	0

To output the measurement report to printer

You can EDIT to change the following parameters in the `Init_setting` subprogram. Printer must be connected to computer by using GPIB cable. The report as shown in example in Figure 9-2 will be printed automatically.

Parameter	Description	Default
Ad_prn	GPIB address for printer	1
Prn_enab	Enable/disables print out function. (1: Enable, 0: Disable)	0

To execute the 4155/4156 calibration

Remove the exclamation marks from program lines shown below, and enter the lines. These lines are in `Init_instrument` subprogram. The calibration will be done automatically before measurement.

```
! CALL Cal415x  
! DISP "Agilent 4155/4156 Calibration Completed"
```

To save the 4155/4156 measurement data

To save the Vth measurement data to a diskette in the 4155/4156's disk drive, remove the exclamation marks from the program lines shown below, and enter the lines. These lines are in the "Save Measurement Data" block of the `Meas_vth` subprogram.

```
! OUTPUT @Hp415x;":MMEM:STOR:TRAC DEF, 'VTH.DAT', 'DISK'"  
! OUTPUT @Hp415x;"*OPC?"  
! ENTER @Hp415x;A
```

The measurement data will be saved to the `VTH.DAT` file after the measurement. If desired, you can use another file name instead of `VTH.DAT`.

To change the Vth measurement setup

You can EDIT the program to change the following parameters in the "Constant Definition" block of the Meas_vth subprogram.

Parameter	Description	Default
Test_comm\$	Comment for the measurement.	"MOSFET Vth Measurement"
Param_file\$	4155/4156 setup file to use.	"E5252.MES"
Vth_max	The maximum Vth limit in V.	2.0
Vth_min	The minimum Vth limit in V.	0.1
Channel\$	E5250A <i>channel_list</i> to use.	"(@10101,10202,10303,10404)"

To change the E5250A input port/output port connections, change the Channel\$ parameter. And if you want to change the E5250A connection functions (Channel Configuration mode, etc.), modify the Set5250init subprogram.

To change the 4155/4156 measurement setup, change the Param_file\$ parameter to the name of your desired setup file.

To change the name of parameter Vth entered from the 4155/4156, change VTH and Vth to the desired name on the 3 lines shown below. Where VTH is the parameter defined by the E5252.MES setup file.

- Meas_vth subprogram, "Measurement" block:

```
OUTPUT @Hp415x;":TRAC? 'VTH'"
ENTER @Hp415x;Vth
```

- Meas_vth subprogram, "Test measurement data" block:

```
IF Vth<Vth_min OR Vth>Vth_max THEN
```

- Meas_vth subprogram, "Reset Instrument" block:

```
OUTPUT Out_str$ USING Img1;Test_num,Result$,Vth_min,Vth_max,Test_comm$
```

Executing Sample Programs
Vth and Capacitance Measurement Program

To change the capacitance measurement setup

You can EDIT the program to change the following parameters in the "Constant Definition" block of the Meas_c subprogram.

Parameter	Description	Default
Test_comm\$	Comment for the measurement.	"Capacitance Measurement"
Capa_max	The maximum capacitance limit in F.	2.0E-11
Capa_min	The minimum capacitance limit in F.	8.0E-12
Sig_volt	Signal level for C measurement in V.	0.03
Meas_freq	Frequency for C measurement in Hz.	1.0E+5
Cable_len	Length (in meters) of 16048D/E cable.	1
Clen_hpriax	Length (in meters) of 16494A cable connected from E5252A output to connector plate.	1.5
Clen_usrtriax_h	Length (in meters) of triaxial cable connected from connector plate to DUT (High terminal of capacitor).	0
Clen_usrtriax_l	Length (in meters) of triaxial cable connected from connector plate to DUT (Low terminal of capacitor).	0
Clen_usrcoax_h	Length (in meters) of coaxial cable connected from connector plate to DUT (High terminal of capacitor).	1.0
Clen_usrcoax_l	Length (in meters) of coaxial cable connected from connector plate to DUT (Low terminal of capacitor).	1.0
Channel\$	E5250A <i>channel_list</i> to use.	"(@10905,11006)"

To change the E5250A input port/output port connections, change the Channel\$ parameter. And if you want to change the E5250A connection functions (Channel Configuration mode, etc.), modify the Set5250init subprogram.

To use the VFP data upload library

If you want to use your VFP data in the program, change the program as follows. Before executing the program, you need to create the VFP data and save it to a file on diskette. And you must link the VFP Data Upload Library to the program. For details, refer to “Using the Virtual Front Panel (VFP) Utility” on page 5-4 and “Using the VFP Data Upload Library” on page 6-22.

1. Insert an exclamation mark (!) at the beginning of each program line shown in the following table, and enter the lines.

Subprogram	Program Line
Meas_vth "Constant Definition" block	Test_comm\$="MOSFET Vth Measurement" Channel\$=" (@10101,10202,10303,10404) "
Meas_vth "Connect to DUT" block	OUTPUT @Hp5250;":ROUT:CLOS "&Channel\$ OUTPUT @Hp5250;"*OPC?" ENTER @Hp5250;A
Meas_vth "Connection All Open" block	OUTPUT @Hp5250;":ROUT:OPEN:CARD ALL" OUTPUT @Hp5250;"*OPC?" ENTER @Hp5250;A
Meas_c "Constant Definition" block	Test_comm\$="Capacitance Measurement" Channel\$=" (@10905,11006) "
Meas_c "Connect to DUT" block	OUTPUT @Hp5250;":ROUT:CLOS "&Channel\$ OUTPUT @Hp5250;"*OPC?" ENTER @Hp5250;A
Meas_c "Connection All Open" block	OUTPUT @Hp5250;":ROUT:OPEN:CARD ALL" OUTPUT @Hp5250;"*OPC?" ENTER @Hp5250;A
Set5250init	OUTPUT @Hp5250;":ROUT:FUNC NCON" OUTPUT @Hp5250;":ROUT:BIAS:STAT ALL,OFF" OUTPUT @Hp5250;":ROUT:CONN:RULE ALL,SROU" OUTPUT @Hp5250;":ROUT:CONN:SEQ ALL,BEM" OUTPUT @Hp5250;":ROUT:OPEN:CARD ALL" OUTPUT @Hp5250;"*OPC?" ENTER @Hp5250;A

Executing Sample Programs

Vth and Capacitance Measurement Program

2. Remove the exclamation marks from program lines shown in the following table, and enter the lines.

Subprogram	Program Line
Meas_vth	! COM /Vfp_com_data/ Setup_data\${14000}
Meas_vth "Constant Definition" block	! Test_comm\$=FNGet_vfp_comment\$(Setup_data\$,Setup_num) See Note ^a .
Meas_vth "Connect to DUT" block	! Connect_vfp(Setup_data\$,Setup_num) See Note ^a .
Meas_vth "Connection All Open" block	! Connect_vfp(Setup_data\$,Setup_num) See Note ^b .
Meas_c	! COM /Vfp_com_data/ Setup_data\${14000}
Meas_c "Constant Definition" block	! Test_comm\$=FNGet_vfp_comment\$(Setup_data\$,Setup_num) See Note ^c .
Meas_c "Connect to DUT" block	! Connect_vfp(Setup_data\$,Setup_num) See Note ^c .
Meas_c "Connection All Open" block	! Connect_vfp(Setup_data\$,Setup_num) See Note ^b .
Set5250init	! COM /Vfp_com_data/ Setup_data\${14000} ! Adrs=Adrs5250 ! CALL Load_vfp_data(Adrs,"VFP_FILE",Setup_data\$) ! CALL Init_vfp_setup(Setup_data\$) See Note ^d .

- a. You must replace the Setup_num parameter with number of the VFP setup memory to use for Vth measurement.
- b. You must replace the Setup_num parameter with number of the VFP setup memory that sets "Open All" (no connection) condition.
- c. You must replace the Setup_num parameter with number of the VFP setup memory to use for C measurement.
- d. In Load_vfp_data subprogram, enter your VFP data file name instead of "VFP_FILE". Your VFP data file must contain data for at least 3 Setup Memories: for Vth measurement, C measurement, and "Open All" condition.

HCI Measurement Program

This section explains how to use and modify the HCI measurement sample program. This section consists of the following sections:

- “Introduction”
- “Adding the Bias Source Control Routine”
- “Setting up the Measurement Environment”
- “Executing the Program”
- “Modifying the Program”

Introduction

The Hot-Carrier-Induced (HCI) degradation of MOSFET parameters is measured by using Agilent 4155/4156 Semiconductor Parameter Analyzer, bias sources, and the E5250A with the E5255A card.

Two HP BASIC language programs are used to perform the HCI measurement:

- HCI Test Program (SP_MUX_M) performs HCI degradation test according to the JEDEC proceeding titled "A PROCEDURE FOR MEASURING HCI" (29-JULY-93).
- Analysis Program (SP_MUX_A) determines the lifetime of MOSFET from the data measured by HCI test program.

The SP_MUX_M program flow is shown in Table 9-5.

Table 9-5 also lists the files that are used to set up the 4155/4156 for each part of the SP_MUX_M program. These setup files are stored on the E5250A Program Disk. So, the program disk must be in the 4155/4156's disk drive when you execute the program.

For details about a 4155/4156 setup file, GET the setup file and refer to the setup by using the 4155/4156.

NOTE

To Add the Bias Source Control Routine

The HCI measurement sample program (SP_MUX_M) requires bias sources. You must modify or add a control routine for your bias sources to the program. Refer to “Adding the Bias Source Control Routine” on page 9-23.

Table 9-5 HCI Degradation Measurement Flow

step	Description	4155/4156 setup file
1	Initializes the Instruments: 1. Resets the 4155/4156. 2. Resets and initializes the E5250A. Configuration Mode: AUTO Bias Mode: OFF Connection Rule: FREE Channel Status: All Relays Open	
2	Determines Stress Condition. See later.	IBVG.MES
3	Selects devices valid for the HCI test. See later.	IGLEAK.MES IDLEAK.MES
4	Characterizes the initial parameters. See later.	PARAM.MES
5	Applies stress and characterizes the parameters. See later.	PARAM.MES

Step 2. Determines Stress Condition

This step determines the gate stress voltage (V_{gstr}) from the I_b - V_{gs} measurement test result. This V_{gstr} value will be used in step 5.

NOTE

Test Device for Defining Stress Conditions

The test device used to determine the stress conditions (step 2) should not be used for Hot-Carrier stress testing (steps 3 to 5).

Step 3. Selects devices valid for the HCI test

This step judges whether each device is valid according to the current leak test result. The `IGLEAK.MES` and `IDLEAK.MES` files are used to set up the 4155/4156 for this step.

As shown below, 24 devices are connected to the E5250A, and measured individually by switching. For devices that fail this step, no further testing is performed, and "0.0" is recorded.

Device Terminal	Device 1	Device2	Device 3	Device 24
Gate	1	2	3	24
Drain	25	26	27	48
Sub	49	50	51	72
Source	GNDU	GNDU	GNDU	GNDU	GNDU

Step 4. Characterizes the initial parameters

This step initially (before stress) measures parameters for the devices that were determined to be valid by the previous step.

The `PARAM.MES` file sets up the 4155/4156.

A summary of the measurement setup saved in `PARAM.MES` is shown below. For details of the setup data, GET the `PARAM.MES` file using the 4155/4156, and refer to the setup displayed on the 4155/4156.

Channel/Source Setup:

SMU	V NAME	I NAME	MODE	FUNCTION	Source Setup
SMU1	VG	IG	V	VAR1	0 to 5V, 20mV step
SMU3	VD	ID	V	CONST	0.1V
SMU4	VB	IB	V	CONST	0V
GNDU	VS	IS	COMMON	CONST	Common

Executing Sample Programs

HCI Measurement Program

User Function Setup:

NAME	UNIT	DEFINITION
Gm	S	DIFF (ID, VG)
Vtext	V	@MX- (@MY1/@MY2) -AT (VD, 1) / 2
Gmmax	S	MAX (Gm)
Vtci	V	@L2X
Idlin	A	@L1Y1

Display Setup:

	Xaxis	Y1axis	Y2axis
NAME	VG	ID	Gm
SCALE	LINEAR	LINEAR	LINEAR
MIN	0 V	0 A	0 S
MAX	5 V	2 mA	1.5 mS

Also the DATA VARIABLES fields set Vtext and Idlin.

Auto Analysis Function:

```
*LINE1: [ GRAD      ] line on [ Y1 ]   at a point where
[ VG      ] = [ 5      ]
[          ]
Gradient: [ 0      ]
-----
*LINE2: [ NORMAL    ] line on [ Y1 ]   at a point where
[ ID      ] = [ 10u    ]
[          ]
and a point [WHERE]
[ ID      ] = [ 10u    ]
-----
*MARKER:  At a point where
[ Gm      ] = [ MAX (Gm) ]
[          ]
-----
*Interpolate: [ON ]
```

PARAM.MES setup file extracts Idlin and Vtci by using the 4155/4156 User Function and Auto Analysis Function. These parameters are extracted with the following conditions:

Idlin: Gate voltage VG=5 V
Substrate voltage VB=0V

Vtci: W/L Ratio (Gate width/Gate length ratio) = 10 μm /1 μm

For changing the conditions, refer to “Modifying the Program” on page 9-35.

Step 5. Applies stress and characterizes the parameters

This step performs the following:

1. Applies the stress, V_{dstr} and V_{gstr} , to the valid devices.

Before running the SP_MUX_M program, you must determine the V_{dstr} (drain stress voltage) by Id-Vds measurement (using setup file IDVD.MES), then edit the SP_MUX_M program to input value of V_{dstr} . Refer to “Executing the Program” on page 9-27.

2. Performs the interim characterization. This sets up the 4155/4156 by using the PARAM.MES setup file, then measures the parameters (I_{dlin} , G_{mmax} , V_{ttext} and V_{tci}) for each device.

3. Judges whether to terminate the stress/interim characterization cycle. This cycle is terminated when total stress time reaches 100,000 sec or when there is no device satisfies all of the following conditions:

- I_{dlin} value is within $\pm 10\%$ of initial value.
- G_{mmax} value is within $\pm 10\%$ of initial value.
- V_{ttext} value is within ± 20 mV of initial value.
- V_{tci} value is within ± 20 mV of initial value.

If none of these termination conditions has occurred, stress time (duration) is increased, and these 3 steps are repeated. The default *cumulative* stress times are defined in the program as follows. To change these *cumulative* stress times, refer to “Modifying the Program” on page 9-35.

Stress cycle	Stress time	Cumulative stress time	Stress cycle	Stress time	Cumulative stress time
1	10 sec	10 sec	8	1000 sec	2000 sec
2	10 sec	20 sec	9	3000 sec	5000 sec
3	30 sec	50 sec	10	5000 sec	10000 sec
4	50 sec	100 sec	11	10000 sec	20000 sec
5	100 sec	200 sec	12	30000 sec	50000 sec
6	300 sec	500 sec	13	50000 sec	100000 sec
7	500 sec	1000 sec			

Executing Sample Programs

HCI Measurement Program

The measurement data is saved to the diskette in disk drive connected to the computer with the following file names.

- IDXX: Percent change data for Idlin
- GMXX: Percent change data for Gmmax
- VTEXX: Relative shift data for Vtext
- VTIXX: Relative shift data for Vtci

where XX means the test device number.

Required Equipments

Prepare the equipment shown in Table 9-6, which lists the required equipment to execute the program:

Table 9-6

Required Equipment

Agilent Model/Part No.	Description	Qty.
E5250A	Low Leakage Switch Mainframe	1
E5255A	24 (8×3) Channel Multiplexer	3
4155/4156	Semiconductor Parameter Analyzer	1
41501	SMU/PGU expander (for GNDU)	1
16494A-001 or -002	Triaxial Cable (1.5 m or 3 m)	1
16494A-003	Triaxial Cable (80 cm)	3
16494D-001 or -002	8 Channel Shielded Coaxial Cable (1.5 m or 3 m)	9
16495D	Connector Plate	1
10833A/B/C	GPIB Cable	5
E5250-17002	E5250A Program Disk (furnished)	1
–	Bias Source	3
–	BNC - BNC cable (for Bias Source)	3
–	3.5 inch diskette (for storing measurement data and modified program)	1

Adding the Bias Source Control Routine

This sample program requires bias sources to apply stress to DUT. So, you must modify the following bias source control subprograms to match your bias sources or create new subprograms. The following subprogram is for bias sources that support SCPI commands:

1. Get the HCI test program (SP_MUX_M) from the E5250A Program Disk by using the computer:

```
GET "SP_MUX_M"
```

2. Delete the exclamation marks (!) from beginning of the following two program lines. You can easily find these lines by using FIND statement.

```
! CALL Bias_source_on
:
! CALL Bias_source_off
```

3. Delete the exclamation mark (!) from the beginning of the following lines in the "Bias_source_on" and "Bias_source_off" subprograms.

Then modify the "OUTPUT" statements to match your Bias Sources. The "SOUR XXX" SCPI command is used to control the output voltage of the Bias Sources.

```
!Bias_source_on:SUB Bias_source_on
! !=====
! ! Bias Source On
! !-----
! COM /Meas_info5/ REAL Vdstr,Vgstr,Vdd,Vbb,Gate_length,Gate_w
idth
! !-----
! OUTPUT 701;"SOUR "&VAL$(Vgstr) ! Set Gate Stress Voltage
! OUTPUT 702;"SOUR "&VAL$(Vdstr) ! Set Drain Stress Voltage
! OUTPUT 703;"SOUR 0.0" ! Set Substrate Stress Voltage
!SUBEND
! !=====
!Bias_source_off:SUB Bias_source_off
! !=====
! ! Bias Source Off
! !-----
! COM /Meas_info5/ REAL Vdstr,Vgstr,Vdd,Vbb,Gate_length,Gate_w
idth
! !-----
! OUTPUT 701;"SOUR 0.0" ! Set Gate Voltage to 0.0V
! OUTPUT 702;"SOUR 0.0" ! Set Drain Voltage to 0.0V
! OUTPUT 703;"SOUR 0.0" ! Set Substrate Voltage to 0.0V
!SUBEND
```

4. Save modified file to an empty *formatted* diskette as in following example. This diskette is used for executing program. And the data measured and analyzed will be saved to this diskette automatically during program execution.

```
RE-STORE "SP_MUX"
```

Setting up the Measurement Environment

Before executing the program, you need to set up the measurement environment as follows:

1. Prepare the equipment shown in Table 9-6, which lists the required equipment to execute the program.
2. For each E5255A, make internal connections, and set the DIP switches. Refer to Figure 9-3.

Three E5255As are used, which are installed in Slot1, Slot2, and Slot3 of the E5250A. The internal connections of the three E5255As are almost the same, *except* for the following:

- IVin1 internal connection (1 in Figure 9-3) for each E5255A:
 - for Slot1: IVin1 to SMU1
 - for Slot2: IVin1 to SMU3
 - for Slot3: IVin1 to SMU4
 - DIP SW settings in each slot are different as shown in Figure 9-3. But within each E5255A, SW1/SW2/SW3 settings are the same.
3. Connect all equipment and devices as shown in Figure 9-4 and Table 9-7. Refer to Chapter 4 for the details of the connection from the E5250A output to Device Under Test (DUT).

Figure 9-3

Internal Connections and DIP SW Settings for E5255As

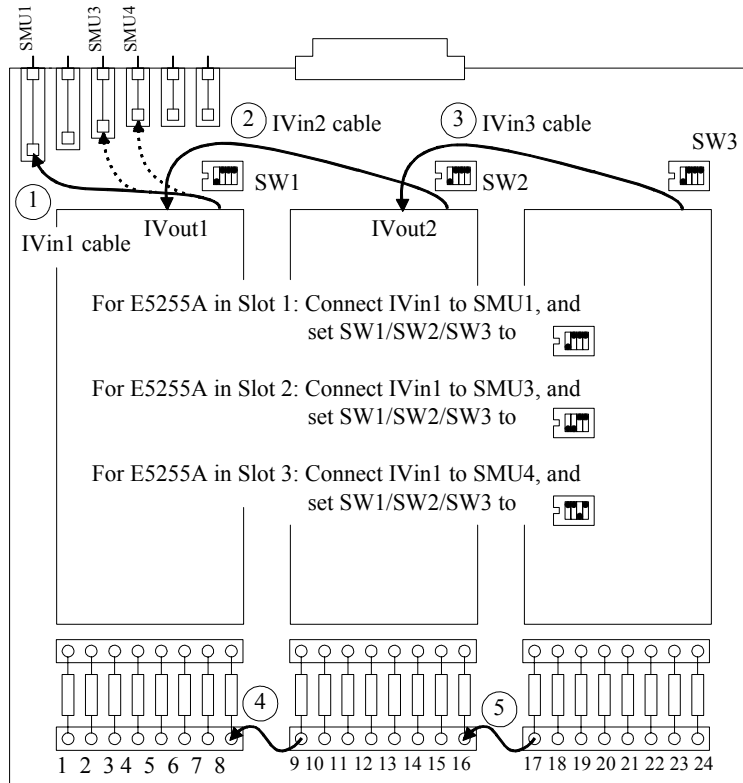

Table 9-7

E5250A Input/Output Connection

4155/4156 Measurement Port	E5250A Input Port	E5255A Output Port	DUT
SMU 1	SMU INPUT 1	Output 1 to 24 (SLOT 1)	Gate
SMU 3	SMU INPUT 3	Output 25 to 48 (SLOT 2)	Drain
SMU 4	SMU INPUT 4	Output 49 to 72 (SLOT 3)	Sub
GNDU	(directly connected to Connector Plate)		Source

Executing Sample Programs
HCI Measurement Program

Figure 9-4 DC HCI Degradation Test Equipment Connections

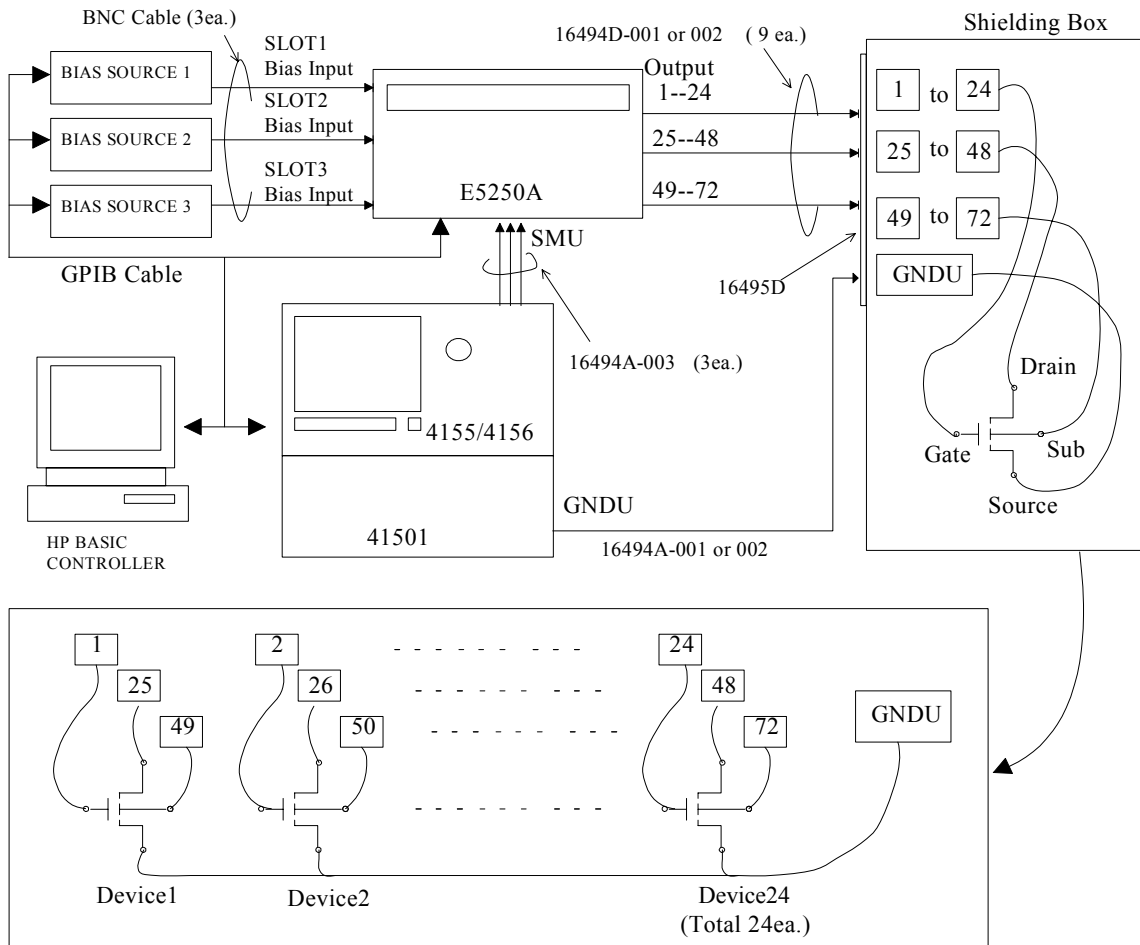

NOTE

Device used to Determine Stress Conditions

HCI test program (SP_MUX_M) uses Device1 above to determine stress voltages (V_{dstr} and V_{gstr}). So, during the program, you are prompted to replace Device1 after these voltages are determined.

Executing the Program

You should have already added the bias source control routine and set up the measurement environment as described previously.

Before running the program, do following:

1. Set the GPIB address of instruments as follows:
 - 4155/4156: 717
 - E5250A: 722
 - Bias Source: Set the GPIB addresses to match your control routine (Address 701 to 703 are defaults used in `SP_MUX_M` program)
2. Turn on all instruments and the computer.
3. Boot up HP BASIC operating system.
4. Insert a diskette into the computer's disk drive. The diskette must contain the HCI test program (`SP_MUX` in this example) you modified in "Adding the Bias Source Control Routine" on page 9-23.
5. Specify the computer's mass storage device (disk drive) the diskette is inserted by using MSI statement. For example, if the device is `":CS80,702,1"`, enter the following command:

```
MSI ":CS80,702,1"
```

6. Load your HCI test program. The following example loads and displays `SP_MUX` program, in this example.

```
LOAD "SP_MUX"  
EDIT
```
7. Insert the E5250A Program Disk into the 4155/4156's disk drive, then get the setup file `IDVD.MES` to set up the 4155/4156.
8. Enter the following command from the command line of the computer:

```
OUTPUT 722;":ROUT:CLOS (@10101,20101,30101)"
```
9. Press Single key on the 4155/4156's front panel. The Id-Vds measurement is performed and the Id-Vds measurement result is displayed as shown in Figure 9-5.
10. Determine the drain stress voltage (`Vdstr`) from the above curve. Recommended maximum value is about 0.5 V below actual breakdown. Then, edit the HCI test program (`SP_MUX` in this example), and define the `Vdstr` value. The value should be defined in the following program line.

Executing Sample Programs HCI Measurement Program

```
!-- Drain stress voltage should be determined by Id-Vd characteristics
Vdstr=5 ! Drain stress voltage
```

After defining the value, re-store the program.

Figure 9-5 Id-Vds Measurement Example

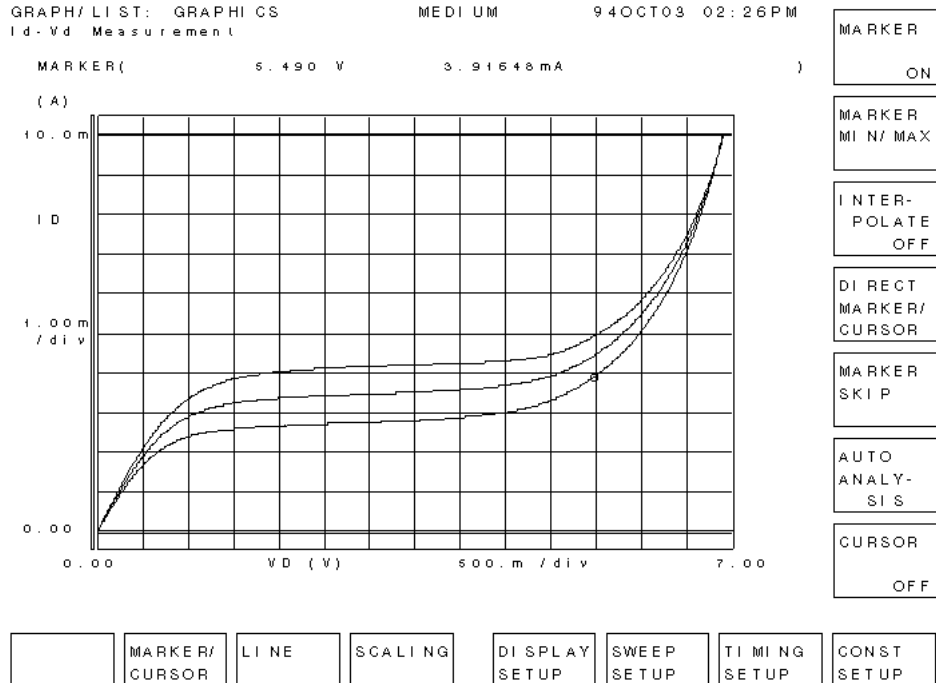

To Execute HCI Test Program

1. Load the HCI test program (SP_MUX in this example), and press RUN function key. Then the following message is displayed on the computer screen.

```
Enter directory name for saving data. (default: test_data)
```

2. Type the name of directory for saving HCI test data, and press **ENTER** key. After executing the program, test data is saved to the directory in the diskette. If you press **ENTER** key with no input, the test data will be saved in "test_data" directory.

After this operation, the Ib-Vgs measurement is automatically executed, and the measurement results are displayed on the 4155/4156, as shown in Figure 9-6.

Also the program automatically extracts the gate stress voltage (Vgstr), which will be used later for stress testing.

3. Remove the device used to determine Vdstr and Vgstr after the following message is displayed.

```
"Connect HCI degradation test devices"
```

This device must be Device1, which was connected to the E5255A output port numbers 1, 25, 49, and GNDU as shown in Figure 9-4.

4. Connect a new device in place of device removed by previous step. Then press Continue function key to continue the program.

The program executes the leakage current tests, which determine the valid devices to use for stress testing.

If the measured leakage currents are within the limit, following message is displayed:

```
"Device No. = XX can be used"
```

If the measured leakage currents are *not* within the limit, following message is displayed:

```
"Device No. = XX shall not be used"
```

Then, the initial characterization (before stress) is performed for all *valid* devices.

Then, stress/interim characterization cycle is executed until stress termination conditions are met as described previously. In each interim characterization, Idlin, Gmmax, Vtext, and Vtci are determined. An example measurement is shown in Figure 9-7.

Figure 9-7

Initial/Interim Characterization Example

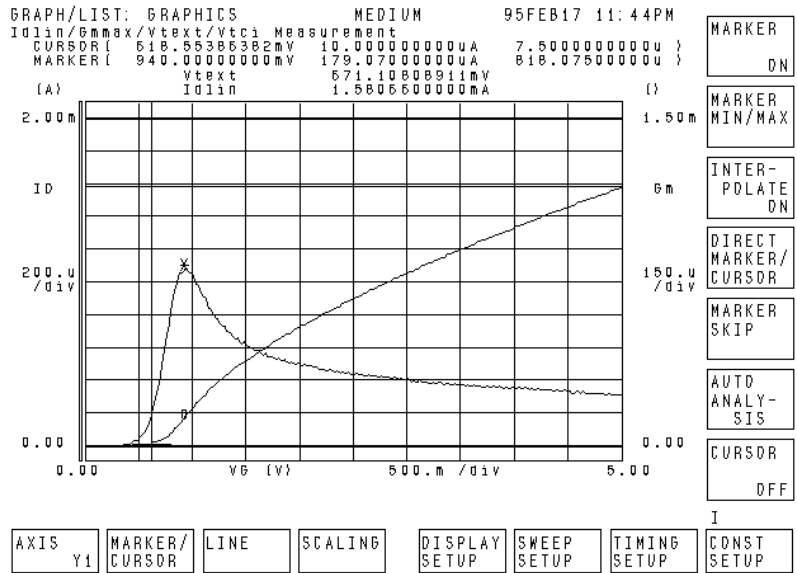
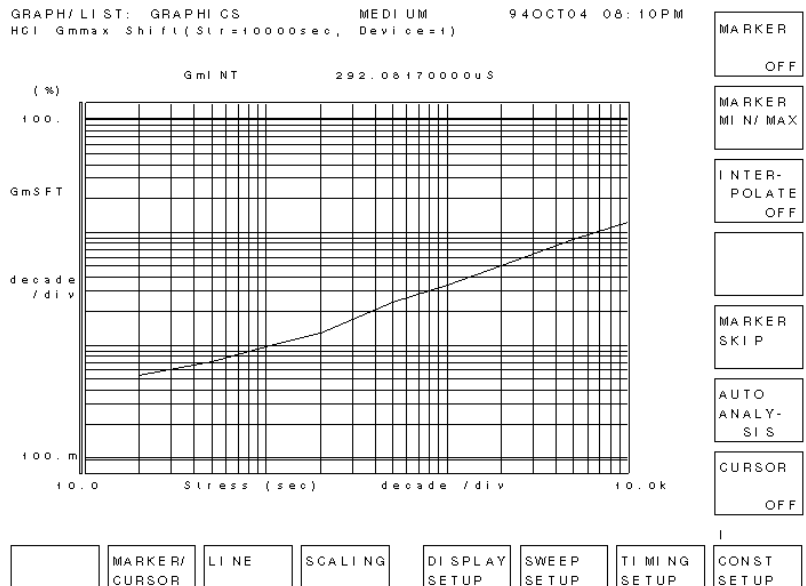

Figure 9-8

HCI Degradation Test Result Example



To Execute Analysis Program

Before running the program, do the following:

1. Insert the E5250A Program Disk into the computer's disk drive.
2. Specify the mass storage device (disk drive) the program disk is inserted by using MSI statement. For example, if the device is ":CS80,702,1", enter the following command:

```
MSI ":CS80,702,1"
```

3. Get the SP_MUX_A program from the program disk.

```
GET "SP_MUX_A"
```
4. Eject the program disk.
5. Insert the diskette which saves test result data into the computer's disk drive.
6. Specify the directory which stores the test result data files. For example, if the directory is /test_data, enter `MSI "/test_data"`.

Execute the SP_MUX_A program as follows:

1. Press the RUN function key on the computer. The following message is displayed.

```
"Enter number of devices (default:24)"
```

2. Enter the number of devices to be analyzed. Default number is 24. Then the following softkeys are displayed.

Softkey	description
Idlin	Extract Tdc from the Idlin data for all valid devices
Gmmax	Extract Tdc from the Gmmax data for all valid devices
Vtext	Extract Tdc from the Vtext data for all valid devices
Vtci	Extract Tdc from the Vtci data for all valid devices
All	Extract Tdc for all these parameters for all valid devices
End	Quit the program

Tdc is the "time to target". The SP_MUX_A program extracts Tdc from the measurement data that was saved by SP_MUX program. Tdc is the time when the device parameter reached its termination condition.

3. Select softkey for parameter for which you want to extract Tdc.
Analysis result and Tdc will be displayed on the 4155/4156 screen as shown in Figure 9-9. Then program pauses. During pause, you can save these results to a 4155/4156's DAT type file.
4. Select Continue function key to continue the program after each graph is displayed.

If you select the ALL softkey in step 3, the 4155/4156 screen displays the graph for the next parameter of the same device number. And then program pauses.

If you select the softkey to specify parameter in step 3, the 4155/4156 screen displays the graph for the next device for the parameter. And program pauses.

This step is repeated according to entered number of devices and selected softkey.

Figure 9-9 HCI Degradation Test Data Analysis Example

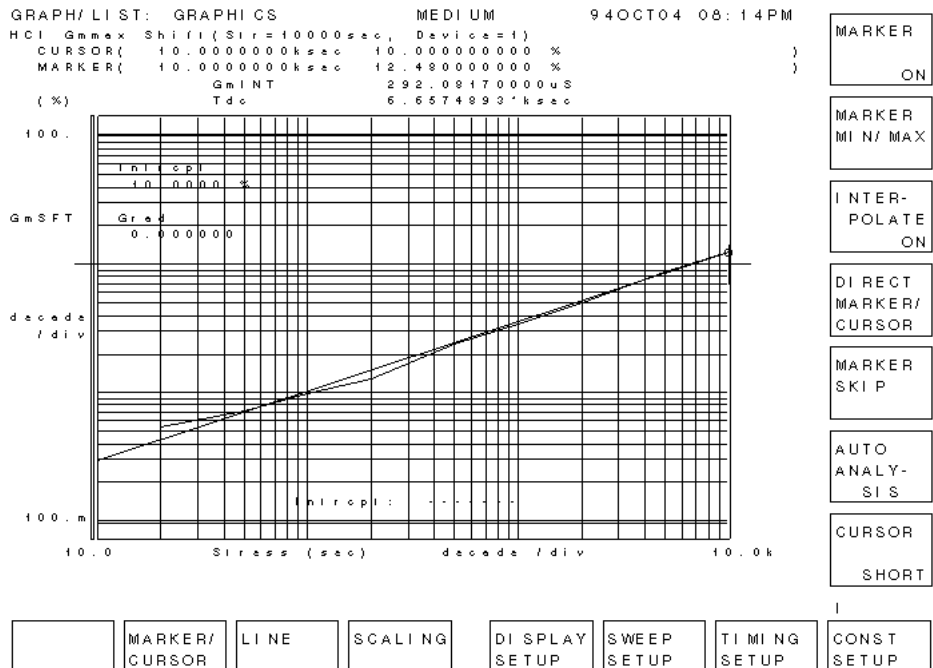

Executing Sample Programs

HCI Measurement Program

NOTE

If you don't want program to pause, change the parameter in SP_MUX_A program to `Pause_to_save=0` before you run the SP_MUX_A program. The program automatically extracts Tdc, saves result data, and stops.

5. All calculated data is saved to ANAHCI file on computer's disk drive, which is an ASCII file. The data is also listed on the 4155/4156's screen. After analyzing, saving, and listing the data, the 4155/4156 is initialized.

For example, in the case that you selected Idlin softkey in step 3, the following is saved to the file:

- *Number of devices*
- *Vdstr, Vgstr, Gate length, Gate width*
- *Idlin*
- *Device ,Validity ,Tdc_idlin*
First device number, 0 or 1, Extracted Tdc for the device
: : :
Last device number, 0 or 1, Extracted Tdc for the device
- *Averaged Tdc_idlin*
Calculated average Tdc

For the above, 0 means valid and 1 means invalid.

Following is an actual example for this case:

```
4
5, 1.95, 1.E-6, 1.E-5
Idlin
Device Validity Tdc_idlin
1, 0, 835.5786
2, 0, 3401.432
3, 0, 6269.047
4, 0, 24366.79
Averaged Tdc_idlin
8718.2119
```

Modifying the Program

This section explains how to modify the SP_MUX_M sample program and PARAM.MES setup file.

- “To change the GPIB address”
- “To change the 4155/4156 setup file used”
- “To change Vtci extraction condition”
- “To change Idlin and Gmmax extraction condition”
- “To change the number of devices”
- “To change the stress times”
- “To change the test limits”
- “To specify the data displayed on the 4155/4156 screen”
- “To change the timing for saving the test data”

To change the GPIB address

To change the GPIB address of the instruments, change the following parameters in the "GPIB Setup" block.

Parameter	Description	Default
Hpib_sc	4155/4156 GPIB select code	7
Hpib_addr	4155/4156 GPIB address	17
Swm_sc	E5250A GPIB select code	7
Swm_addr	E5250A GPIB address	22

To change the 4155/4156 setup file used

To change the 4155/4156's setup file used for the HCI test program, modify the setting of the setup file and save it as a new setup file. Then change the following parameter in the "Definition of measurement and stress setup files" block of the program.

Parameter	Description	Default
Ibvg_file\$	Setup file for extracting Vgstr.	"IBVGMES"
Igleak_file\$	Setup file for Gate leakage current measurement.	"IGLEAK.MES"
Idleak_file\$	Setup file for Drain leakage current measurement.	"IDLEAK.MES"
Param_file\$	Setup file for parameter measurement.	"PARAM.MES"

To change Vtci extraction condition

To change W/L ratio (Gate width/Gate length ratio) required for Vtci extraction, do follows.

1. GET the PARAM.MES setup file by using the 4155/4156.
2. Change the setting of "ID" parameter in "LINE2" on the ANALYSIS SETUP screen. The value of "ID" can be calculated by the following expression.

$$ID=1 \mu A \times W/L$$

where, W means Gate width in m, and L means Gate length in m.

3. Change the following parameters in the "Device geometries" block of program.

Parameter	Description	Default
Gate_length	Gate length in m.	1.E-6
Gate_width	Gate width in m.	1.E-5

To change Idlin and Gmmax extraction condition

To change Gate voltage and Substrate voltage required for Idlin and Gmmax extraction, do follows.

1. GET the PARAM.MES setup file by using the 4155/4156.
2. Change the value of Substrate voltage "VB" on the SOURCE SETUP screen.
3. Change the setting of "VG" parameter in "LINE1" on the ANALYSIS SETUP screen.

To change the number of devices

Change the setting of the `No_of_devices` variable in the "Input Parameters" block.

To test more than 25 devices, you must change the configuration of the E5250A. See chapter 2.

To change the stress times

Change the data at the DATA statement in the "Stress duration setup" block. Each data shows the cumulative stress data.

Example:

```
DATA      10,      20,      50
DATA     100,     200,     500
DATA    1000,    2000,    5000
DATA   10000,  20000,  50000
DATA  100000
```

If you change the number of the data defined in DATA statements, change the value of the `Meas_points` variable in the "Stress duration setup" block.

The value of `Meas_points` must be the same number as the number of data defined in the DATA statements.

In the above example, the number of data in DATA statements is 13. So the variable for the above example must be set as follows.

```
Meas_points=13
```

To change the test limits

Each test device is judged to be valid or not by measuring the gate and drain leakage currents. Change the following parameters in "Limits for leakage tests" block.

Parameter	Description	Default
Igleak_max	Maximum Gate leakage current in A.	2.E-10
Idleak_max	Maximum Drain leakage current in A.	1.E-8

To specify the data displayed on the 4155/4156 screen

Change the following parameters in the "Setup for drawing / saving data in main menu" block.

Parameter	Description	Default
Show_device	To display the data for the specified device number. 0: Displays the data for all devices. <i>n</i> (integer): Displays the data for device No. <i>n</i> .	0
Show_param	To display the data for the specified parameter. 0: Displays the data for all parameters. 1: Displays Idlin data. 2: Displays Gmmax data. 3: Displays Vtext data. 4: Displays Vtci data. -1: No data is displayed.	0

To change the timing for saving the test data

Change the following parameter in the "Setup for drawing / saving data in main menu" block.

- Save_at_last=0: Saves the data after each parameter measurement.
- Save_at_last=1: Saves the data after HCI test is completely finished.

For this parameter, the default is 1.

10 **Specifications**

Specifications

This chapter lists specifications, typical data and supplemental data for the Agilent E5250A Low Leakage Switch Mainframe with the Agilent E5252A 10×12 Matrix Switch and the Agilent E5255A 24 (8×3) Channel Multiplexer. This chapter also provides the supplemental data when used with the Agilent 4155/4156.

The specifications are the performance standards or limits against which these units have been tested. The typical data and supplemental data are not warranted, but provide useful information about functions and performance.

If not noted otherwise, the conditions for specifications and other data are as follows:

Temperature: 23 °C ± 5 °C

Humidity: < 60 % RH

General Specifications

Temperature Range:	Operating: 5 °C to 40 °C Storage: -40 °C to 70 °C
Humidity Range:	Operating: 5 % to 80 % RH (non-condensing) Storage: 5 % to 90 % RH at 65 °C
Altitude:	Operating: 0 to 2,000 m (6,500 ft) Storage: 0 to 15,240 m (50,000 ft)
Power Requirement:	100 to 240V ± 10 %, 47 to 63 Hz
Maximum VA:	100 VA
Number of Slots:	4 slots for 30 mm height switch cards
Dimensions:	E5250A: 230 mm H × 430 mm W × 600 mm D E5252A: 30 mm H × 395 mm W × 424 mm D E5255A: 30 mm H × 395 mm W × 424 mm D
Weight:	E5250A: 11.2 kg E5252A: 2.0 kg E5255A: 2.1 kg
E5252A Number of Input Ports:	Low Leakage I-V Port: 2 ports General I-V Port: 4 ports C-V Port: 2 ports HF Port: 2 ports
E5255A Number of Input Ports:	Low Leakage I-V Port: 1 port/multiplexer block Bias Port: 1 port/multiplexer block
Number of Output Ports:	(depends on the number of cards) For <i>each</i> E5252A: 12 For <i>each</i> E5255A: 24 (8 ports × 3 multiplexer blocks)

Agilent E5252A 10x12 Matrix Switch

Switch Specifications

These are specifications when the E5252A is installed in mainframe. In the table, the conditions are as follows:

- **A:** 23 °C ± 5 °C, 5 % to 60 % RH
- **B:** 5 °C to 18 °C and 28 °C to 40 °C, 5 % to 60 % RH
- **C:** 28 °C to 40 °C, 60 % to 80 % RH

	A	B	C
Max. Current Rating (A)	1.0	1.0	1.0
Max. Voltage Rating (V)			
Channel to Guard	200	200	200
Channel to Channel	300	300	300
Closed Channel Residual Resistance (Ω)			
Low Leakage I-V Port	0.6	0.6	0.6
General I-V Port	1.0	1.0	1.0
C-V, HF Port	1.0	1.0	1.0
Channel Isolation Resistance (Ω)			
Low Leakage I-V Port	10^{13}	5×10^{12}	2×10^{12}
General I-V Port	10^{12}	5×10^{11}	2×10^{11}
C-V, HF Port	10^9	5×10^8	2×10^8

Typical Data

Offset Current	< 0.1 pA ^{*1} (Low Leakage I-V Port) < 1000 pA ^{*1} (General I-V Port)
Channel Crosstalk Capacitance	< 0.3 pF per channel
Offset Voltage (EMF) at 5 min ^{*2}	< 80 μ V (Low Leakage I-V Port) < 110 μ V (General I-V Port) < 110 μ V (C-V, HF Port)
Guard Capacitance	< 145 pF ^{*3} (Low Leakage I-V Port) < 123 pF ^{*3} (General I-V Port)
C Measurement Error	< $\pm 1\% \pm 0.5$ pF ^{*4} (C-V Port)

***1** The offset current when 0V is applied to all I/O channels.

***2** EMF means Electro Motive Force, and these are offset voltages after applying voltage and waiting 5 minutes.

***3** This is guard capacitance for an I/O channel for following conditions. Only one E5252A is installed in mainframe, and only one I/O channel is connected.

***4** When capacitance compensation routine is used for following measurement conditions:

Frequency: 1 kHz to 1 MHz

Measurement Range: Maximum 1000 pF

Measurement Terminal: At the end of Agilent 16495A-001 (1.5 m triaxial cable) connected to the E5252A output terminal.

See "Using the Capacitance Compensation Routine" on page 6-28.

Supplemental Data

Bandwidth (at -3dB)	< 10 MHz (C-V, HF Port)
Relay Contact Life	> 10^8 times (Dry Switching Mode)
Settling Time	< 3.5 sec to settle to within 400 fA of final value when 10 V is applied (Low Leakage I-V Port)

Agilent E5255A 24 (8x3) Channel Multiplexer

Switch Specifications

These are specifications when the E5255A is installed in mainframe. In the table, the conditions are as follows:

- **A:** 23 °C ± 5 °C, 5 % to 60 % RH
- **B:** 5 °C to 18 °C and 28 °C to 40 °C, 5 % to 60 % RH
- **C:** 28 °C to 40 °C, 60 % to 80 % RH

	A	B	C
Max. Current Rating (A)	1.0	1.0	1.0
Max. Voltage Rating (V)			
Channel to Guard	200	200	200
Channel to Channel	300	300	300
Closed Channel Residual Resistance (Ω)			
Low Leakage I-V Port	0.6	0.6	0.6
BIAS Port ^a	1.0	1.0	1.0
Channel Isolation Resistance (Ω)			
Low Leakage I-V Port	10^{13}	5×10^{12}	2×10^{12}
BIAS Port	10^9	5×10^8	2×10^8

a. When 0 Ω resistors are mounted on the card as the protective resistor.

Typical Data

Offset Current: < 0.1 pA ^{*1} (Low Leakage I-V Port)

Channel Crosstalk Capacitance: < 0.4 pF/channel (Low Leakage I-V Port)

< 5 pF/channel (Bias Port)

Offset Voltage (EMF) at 5min^{*2}: < 80 μ V (Low Leakage I-V Port)

Guard Capacitance

(Low Leakage I-V Port): < 180 pF^{*3}

< 60 pF (when the port is open.)

*1 The offset current when 0 V is applied to all I/O channels.

*2 EMF means Electro Motive Force, and these are offset voltages after applying voltage and waiting 5 minutes.

*3 This is guard capacitance for an I/O channel for following conditions. Only one E5255A is installed in mainframe, and only one I/O channel is connected.

Supplemental Data

Relay Contact Life: > 10⁸ times (Dry Switching Mode)

Settling Time: < 3.5 sec to settle to within 400 fA of final value when 10 V is applied (Low Leakage I-V Port)

Accessories

The following specifications are applied for the accessories listed below.

Temperature Range

Operating: 5 °C to 40 °C

Storage: -40 °C to 70 °C

Humidity Range

Operating: 5 % to 80 % RH (non-condensing)

Storage: 5 % to 90 % RH at 65 °C

- Agilent 16494A Triaxial Cable
- Agilent 16494B Kelvin Triaxial Cable
- Agilent 16494C Kelvin Triaxial Cable for Agilent 4142B
- Agilent 16494D 8ch Shielded Coaxial Cable
- Agilent 16495C Connector Plate with 6 8ch Shield,Intlk/GNDU
- Agilent 16495D Connector Plate with 12 8ch Shield,Intlk/GNDU
- Agilent 16495E Half size Blank Plate
- Agilent 16495F Connector Plate with 12 Triax.,Intlk/GNDU
- Agilent 16495G Connector Plate with 24 Triax.,Intlk/GNDU

The following specifications are applied for the Agilent 16494E Wide Temperature 8ch Shielded Coaxial Cable.

Temperature Range

Operating: 5 °C to 40 °C (for connector part)
-50 °C to 200 °C (for cable part)

Storage: -40 °C to 70 °C

Humidity Range

Operating: 5 % to 80 % RH (non-condensing)

Storage: 5 % to 90 % RH at 65 °C

Supplemental Data when used with Agilent 4155/4156

The below data shows degradation of Agilent 4155/4156 when used with Low Leakage I-V Port.

I_{out} is output current in A, and V_{out} is output voltage in V.

Supplemental Data when used with Agilent 4155

- Voltage Range Offset Accuracy (with MPSMU)

Range	Setting	Measurement
2 V	$960 \mu\text{V} + (0.5 \times I_{out}) \text{ V}$	$780 \mu\text{V} + (0.5 \times I_{out}) \text{ V}$

- Current Range Offset Accuracy (with MPSMU)

Range	Setting	Measurement
1 nA	$3 \text{ pA} + (0.2 \times V_{out}) \text{ pA}$	$3 \text{ pA} + (0.2 \times V_{out}) \text{ pA}$
10 nA	$7 \text{ pA} + (0.2 \times V_{out}) \text{ pA}$	$5 \text{ pA} + (0.2 \times V_{out}) \text{ pA}$
100 nA	$50 \text{ pA} + (0.4 \times V_{out}) \text{ pA}$	$30 \text{ pA} + (0.4 \times V_{out}) \text{ pA}$

Supplemental Data when used with Agilent 4156 (non-Kelvin connection)

- Voltage Range Offset Accuracy (with HRSMU)

Range	Setting	Measurement
2 V	$500 \mu\text{V} + (0.5 \times I_{out}) \text{ V}$	$280 \mu\text{V} + (0.5 \times I_{out}) \text{ V}$

- Current Range Offset Accuracy (with HRSMU)

Range	Setting	Measurement
10 pA	$0.4 \text{ pA} + (0.2 \times V_{out}) \text{ pA}$	$0.1 \text{ pA} + (0.2 \times V_{out}) \text{ pA}$
100 pA	$0.4 \text{ pA} + (0.2 \times V_{out}) \text{ pA}$	$0.1 \text{ pA} + (0.2 \times V_{out}) \text{ pA}$
1 nA	$0.7 \text{ pA} + (0.2 \times V_{out}) \text{ pA}$	$0.5 \text{ pA} + (0.2 \times V_{out}) \text{ pA}$
10 nA	$4 \text{ pA} + (0.2 \times V_{out}) \text{ pA}$	$2 \text{ pA} + (0.2 \times V_{out}) \text{ pA}$
100 nA	$40 \text{ pA} + (0.3 \times V_{out}) \text{ pA}$	$20 \text{ pA} + (0.3 \times V_{out}) \text{ pA}$

Specifications

Supplemental Data when used with Agilent 4155/4156

11 **Error Messages**

Error Messages

This chapter lists and describes the error messages for Agilent E5250A. An error message consists of an error number and message.

There are two types of error messages:

- Standard SCPI Error Messages
Negative error numbers (Command Error, Execution Error, Device-Dependent Error, and Query Error) are standard SCPI errors.
- E5250A Specific Error Messages
Positive error numbers are the E5250A specific errors.

Error messages are classified by error number as listed in the following table:

Error Range	Error Category
0	No error
-100 to -199	Command Error
-200 to -299	Execution Error
-300 to -399	Device-Dependent Error
-400 to -499	Query Error
100 to 32767	E5250A Specific Error

When an error occurs, the corresponding bit is set in the Standard Event Status Register (see Chapter 7):

Error Category	Standard Event Status Register Bit
Command Error	bit5
Execution Error	bit4
Device-Dependent Error	bit3
Query Error	bit2
E5250A Specific Error	bit3

Also, the error number and message are placed in the error queue, which can be read by the `:SYSTEM:ERROR?` query command. The error queue is cleared by the common command `*CLS`, and when power is turned on. For these commands, see Chapter 7.

Standard SCPI Error Messages

Standard SCPI error messages have negative error numbers. The following are the standard SCPI error messages for the E5250A:

Command Error

If syntax of SCPI command is *not* valid, a *-1XX* error occurs. The error number and message are placed in the error queue, and bit5 of the Standard Event Status Register is set.

A SCPI command consists of a **command header** and zero or more **parameters**. The following are example SCPI commands:

- Subsystem command: `:ROUT:OPEN:CARD 1`

`:ROUT:OPEN:CARD` is the command header, and `1` is the parameter.

A subsystem command header consists of mnemonics (keywords) separated by colons. Query commands have a question mark (?) at end of last mnemonic.

- Common command: `*SRE 48`

`*SRE` is the command header, and `48` is the parameter.

A common command header consists of an asterisk (*) followed by 3 characters. Query commands have a question mark (?) at end of header.

Error Number	Error Message and Description
-100	Command error Generic syntax error that cannot be determined more specifically.
-101	Invalid character A syntax element contains a character that is invalid for that type of element; for example, a header containing an ampersand.
-102	Syntax error An unrecognized command or data type was received; for example, a string was received when the E5250A does not accept strings.

Error Messages
Standard SCPI Error Messages

Error Number	Error Message and Description
-103	<p>Invalid separator</p> <p>An illegal character was received when a separator was expected; for example, the semicolon was omitted between multiple commands in a program message.</p>
-104	<p>Data type error</p> <p>An improper data type was received; for example, numeric data was expected but string data was received.</p>
-105	<p>GET not allowed</p> <p>A group execute trigger was received within a program message.</p>
-108	<p>Parameter not allowed</p> <p>Too many parameters for the command were received.</p>
-109	<p>Missing parameter</p> <p>Fewer parameters were received than required for the command.</p>
-110	<p>Command header error</p> <p>An error was detected in the header. This error message is reported if the E5250A cannot determine the more specific header errors -111 through -114.</p>
-111	<p>Header separator error</p> <p>An illegal character for a header separator was received; for example, no white space between the command header and parameter.</p>
-112	<p>Program mnemonic too long</p> <p>A keyword in the command header contains more than twelve characters.</p>
-113	<p>Undefined header</p> <p>An undefined command header was received; for example, *XYZ or :ROUT:OPEN:COOD.</p>

Error Number	Error Message and Description
-120	<p>Numeric data error</p> <p>An error was detected in a numeric parameter (including the non-decimal numeric types). This error message is reported when the E5250A cannot determine the more specific errors -121 through -128.</p>
-121	<p>Invalid character in number</p> <p>An invalid character for the parameter was received; for example, an alphacharacter was received when the parameter type was decimal numeric.</p>
-123	<p>Exponent too large</p> <p>The magnitude of the exponent for a numeric parameter was larger than 32000.</p>
-124	<p>Too many digits</p> <p>The mantissa of a decimal numeric parameter contained more than 255 digits excluding leading zeros.</p>
-128	<p>Numeric data not allowed</p> <p>Numeric data is not allowed in this position for this command.</p>
-138	<p>Suffix not allowed</p> <p>A suffix was received after a numeric parameter. For the E5250A, no parameters have suffix.</p>
-140	<p>Character data error</p> <p>An error was detected in a character parameter. This error message is reported if the E5250A cannot determine the more specific errors -141 through -148.</p>
-141	<p>Invalid character data</p> <p>Either the character parameter contains an invalid character or the particular element received is not valid for the command.</p>
-144	<p>Character data too long</p> <p>The character parameter contains more than 12 characters.</p>

Error Messages
Standard SCPI Error Messages

Error Number	Error Message and Description
-148	<p>Character data not allowed</p> <p>A character parameter is not allowed for this position.</p>
-150	<p>String data error</p> <p>An error was detected in a string parameter. This error is reported if the E5250A cannot determine a more specific error -151 and -158.</p>
-151	<p>Invalid string data</p> <p>An invalid string parameter data was received; for example, an END message was received before the terminal quote character.</p>
-158	<p>String data not allowed</p> <p>A string parameter data was received but was not allowed at this point.</p>
-160	<p>Block data error</p> <p>An error was detected in a block data. This error is reported if the E5250A cannot determine more specific errors -161 and -168.</p>
-161	<p>Invalid block data</p> <p>An invalid block data was received; for example, an END message was received before the length was satisfied.</p>
-168	<p>Block data not allowed</p> <p>A legal block data was received but was not allowed at this point.</p>
-170	<p>Expression error</p> <p>An error was detected in an expression. This error is reported if the E5250A cannot determine more specific errors -171 and -178.</p>
-171	<p>Invalid expression</p> <p>The expression was invalid; for example, unmatched parentheses or an illegal character.</p>
-178	<p>Expression data not allowed</p> <p>An expression was received but was not allowed at this point.</p>

Execution Error

If syntax of a SCPI command header and parameter is valid, but the command cannot be executed due to some condition of the E5250A, a -2XX error occurs. The error number and message are placed in the error queue, and bit4 of the Standard Event Status Register is set.

Error Number	Error Message and Description
-200	<p>Execution error</p> <p>Generic execution error that cannot be determined more specifically.</p>
-220	<p>Parameter error</p> <p>The parameter value is valid, but not executable due to some condition of the E5250A. This error occurs if more specific errors -221 through -224 cannot be determined.</p>
-222	<p>Data out of range</p> <p>A valid parameter setting could not be executed because interpreted value was out of range as defined by the E5250A.</p>
-223	<p>Too much data</p> <p>A valid parameter setting (block, expression, or string type) could not be executed because parameter contained more data than the E5250A could handle due to insufficient memory or other requirements.</p>
-224	<p>Illegal parameter value</p> <p>A valid parameter setting (where exact value from list of possibles was expected) could not be executed due to present E5250A state.</p>
-260	<p>Expression error</p> <p>An expression related error occurred.</p>

Device-Dependent Errors

-3XX errors indicate that an E5250A operation did not properly complete, possibly due to an abnormal hardware or firmware condition. These negative codes are SCPI defined. For the device-dependent positive error codes, see “E5250A Specific Error Messages” on page 11-10. The positive codes are not SCPI defined.

For these errors, an error number and message are placed in the error queue, and bit3 of the Standard Event Status Register is set.

Error Number	Error Message and Description
-300	Device-specific error Generic device-dependent error for the E5250A that cannot be determined more specifically.
-311	Memory error An error was detected in the E5250A's memory.
-350	Queue overflow If error queue is full, this code is entered into the error queue instead of the code that caused the error. This code indicates that there was no room in the error queue, so an error occurred but was not recorded.

Query Errors

If the output queue control of the E5250A detects one of following problems, a -4XX error occurs:

- An attempt was made to read data from the output queue when no output data is present or pending.
- Data in the output queue has been lost.

If this type of error occurs, the error number and message are placed in the error queue, and bit2 of the Standard Event Status Register is set.

Error Number	Error Message and Description
-400	Query error Generic query error for the E5250A that cannot be determined more specifically.
-410	Query INTERRUPTED A condition causing an INTERRUPTED query error occurred; for example, a query followed by DAB or GET before a response was completely sent.
-420	Query UNTERMINATED A condition causing an UNTERMINATED query error occurred; for example, the E5250A was addressed to talk and an incomplete program message was received.
-430	Query DEADLOCKED A condition causing a DEADLOCKED query error occurred; for example, both input buffer and output buffer are full and the E5250A cannot continue.
-440	Query UNTERMINATED after indefinite response A query was received in the same program message after a query requesting an indefinite length response was executed.

E5250A Specific Error Messages

These are the E5250A-specific errors that are not defined by SCPI. These errors indicate that an E5250A operation did not properly complete due to card, channel, port, or mode errors.

For the SCPI defined device-dependent codes, see “Device-Dependent Errors” on page 11-8.

For these errors, an error number and message are placed in the error queue, and bit3 of the Standard Event Status Register is set.

The E5250A specific error messages have positive error numbers.

E5250A Channel Related Errors

Error Number	Error Message and Description
2000	Invalid card number Wrong card number is specified in card number or channel list parameter. Make sure card is properly installed in the correct E5250A slot.
2001	Invalid channel number Wrong channel number is specified in the channel list. Confirm the channel number, the card configuration, and the configuration mode of the E5250A.
2006	Command not supported on this card Command was used that is not supported by the card.
2009	Too many channels in channel list Too many channels are specified in the channel list. Maximum number of channels: <ul style="list-style-type: none">• E5252A: number of cards × 120• E5255A: number of cards × 48
2011	Empty channel list No channel list is specified.
2012	Invalid channel range Wrong channel list is defined. Confirm the syntax of the channel list, the card configuration, and the configuration mode of the E5250A.

E5250A Card/Mode/Port Related Errors

Error Number	Error Message and Description
3000	Card0 initialization fail The E5250A may be defective. Contact your nearest Agilent Technologies service center.
3001	Card1 initialization fail The E5250A or card installed in slot 1 of the E5250A may be defective. Or if card is the E5255A, the internal cable connection or the DIP switch setting may be wrong.
3002	Card2 initialization fail The E5250A or card installed in slot 2 of the E5250A may be defective. Or if card is the E5255A, the internal cable connection or the DIP switch setting may be wrong.
3003	Card3 initialization fail The E5250A or card installed in slot 3 of the E5250A may be defective. Or if card is the E5255A, the internal cable connection or the DIP switch setting may be wrong.
3004	Card4 initialization fail The E5250A or card installed in slot 4 of the E5250A may be defective. Or if card is the E5255A, the internal cable connection or the DIP switch setting may be wrong.
3011	Bad couple port number For the <i>Input Port No.</i> for Couple Port, only 1, 3, 5, 7, or 9 are allowed.
3012	Bad bias port number For <i>Input Port No.</i> for Bias Port, only 1 to 10 are allowed.

Error Number	Error Message and Description
3013	<p>Cannot connect multiple channels in SROUTe mode</p> <p>Incorrect channel list for Single connection rule. For Single connection rule, an input port cannot be connected to multiple output ports, and an output port cannot be connected to multiple input ports. Change channel list or change connection rule to Free.</p>
3014	<p>Cannot directly specify Bias Port channel</p> <p>Incorrect channel number when Bias Mode ON is specified in the channel list. Cannot directly specify the channel number for the Bias Port.</p>
3015	<p>Bad channel number combination on E5252A card</p> <p>Wrong input port combination is specified in the channel list for the E5252A card. For input ports, can specify only one of input port numbers 5, 7, and 9, and only one of input port numbers 6, 8, and 10. For example, channel list cannot specify input ports 5 and 7.</p>
3016	<p>Config error. Re-install E5255A.</p> <p>May be problem with the E5255A installation. Re-install the E5255A.</p>
3017	<p>Too many relays closed. Max 200.</p> <p>Too many physical relays have been closed. To close new relays, must open some relays. Maximum 200 relays can be closed.</p>
3018	<p>Can't change to AConfig mode. Check card config.</p> <p>The present card configuration of the E5250A does not allow the Auto Config mode. Change the E5250A card configuration to allow Auto configuration mode.</p>
3019	<p>Cannot use same port for Couple and Bias</p> <p>Same input port number is specified to be Couple Port and Bias Port. Couple Port and Bias Port cannot be the same port.</p>

Error Messages
E5250A Specific Error Messages

SCPI Command Summary

This chapter is a quick reference for the SCPI subsystem commands available for Agilent E5250A. The commands are in alphabetical order.

For details about these commands, see Chapter 7.

For how to specify the *channel_list* parameter, see Chapter 5.

Textual Notation for Subsystem Commands

- [] Square brackets are used to enclose optional information not required for execution of the command sequence. So, you can omit the characters in brackets, and the command will still execute correctly.
- For example, for the [:ROUte]:BIAS:PORT command, you can execute :ROUT:BIAS:PORT or :BIAS:PORT, which are exactly the same.
- italic font* Text you supply. For example, for *card_number*, you enter an allowed card number. Also, used to represent response data.

Command	Description
:DIAG:TEST:CARD:CLE <i>card_number</i>	Clears relay test result (pass/fail) of specified card. <i>card_number</i> : 1, 2, 3, 4, or ALL
:DIAG:TEST:CARD[:EXEC]? <i>card_number</i>	Executes relay test, then returns result: 1: fail card exists, 0: pass <i>card_number</i> : 1, 2, 3, 4, or ALL
:DIAG:TEST:CARD:STAT? <i>card_number</i>	Returns most recent relay test result: 1: fail, 0: pass, -1: not tested. <i>card_number</i> : 1, 2, 3, 4
:DIAG:TEST:FRAM:CLE <i>unit</i>	Clears specified test result. <i>unit</i> : CONT (controller test), or FPAN (front panel interface test)
:DIAG:TEST:FRAM[:EXEC]? <i>unit</i>	Executes specified test, then returns test result: 1: fail, 0: pass. <i>unit</i> : CONT (controller test), or FPAN (front panel interface test)
:DIAG:TEST:FRAM:STAT? <i>unit</i>	Returns most recent test result of specified test: 1: fail, 0: pass, -1: not tested. <i>unit</i> : CONT: Controller test FPAN: Front panel interface test
[:ROUT]:BIAS:CHAN:DIS:CARD <i>card_number</i>	Bias disables all channels of specified card. <i>card_number</i> : For Auto Config mode: 0 or ALL For Normal Config mode: 1, 2, 3, 4, or ALL
[:ROUT]:BIAS:CHAN:DIS[:LIST] (@ <i>channel_list</i>)	Bias disables the specified channels. <i>channel_list</i> : Channels to bias disable.
[:ROUT]:BIAS:CHAN:DIS[:LIST]? (@ <i>channel_list</i>)	Returns whether specified channels are bias disabled. 1: disabled, 0: enabled. <i>channel_list</i> : Channels to check.

SCPI Command Summary

Command	Description
<code>[:ROUT] :BIAS :CHAN :ENAB :CARD <i>card_number</i></code>	Bias enables all channels in the specified card. <i>card_number</i> : For Auto Config mode: 0 or ALL For Normal Config mode: 1, 2, 3, 4, or ALL
<code>[:ROUT] :BIAS :CHAN :ENAB [:LIST] (@<i>channel_list</i>)</code>	Bias enables the specified channels. <i>channel_list</i> : Channels to bias enable.
<code>[:ROUT] :BIAS :CHAN :ENAB [:LIST] ? (@<i>channel_list</i>)</code>	Returns whether specified channels are bias enabled. 1: enabled, 0: disabled. <i>channel_list</i> : Channels to check.
<code>[:ROUT] :BIAS :PORT <i>card_number, bias_port</i></code>	Selects which input port is the Bias port on specified card. Only for the E5252A card. <i>card_number</i> : For Auto Config mode: 0 or ALL For Normal Config mode: 1, 2, 3, 4, or ALL <i>bias_port</i> : 1 to 10
<code>[:ROUT] :BIAS :PORT ? <i>card_number</i></code>	Returns the input Bias Port number for the specified card. Only for the E5252A card. <i>card_number</i> : For Auto Config mode: 0 For Normal Config mode: 1, 2, 3, 4
<code>[:ROUT] :BIAS [:STAT] <i>card_number, state</i></code>	Turns Bias Mode ON or OFF for the specified card. <i>card_number</i> : For Auto Config mode: 0 or ALL For Normal Config mode: 1, 2, 3, 4, or ALL <i>state</i> : ON or 1: turn ON Bias Mode OFF or 0: turn OFF Bias Mode
<code>[:ROUT] :BIAS [:STAT] ? <i>card_number</i></code>	Returns the Bias Mode for the specified card. 0: Bias Mode is OFF, 1: Bias Mode is ON. <i>card_number</i> : For Auto Config mode: 0 For Normal Config mode: 1, 2, 3, 4

Command	Description
[:ROUT]:CLOS:CARD? <i>card_number</i>	<p>Returns <i>channel_list</i> of all closed channels for the specified card. "Closed channel" means an input port connected to an output port.</p> <p><i>card_number</i>: For Auto Config mode: 0 For Normal Config mode: 1, 2, 3, or 4</p>
[:ROUT]:CLOS[:LIST] (@ <i>channel_list</i>)	<p>Connects input ports to output ports as specified in <i>channel_list</i>.</p> <p><i>channel_list</i>: Channels to close.</p>
[:ROUT]:CLOS[:LIST]? (@ <i>channel_list</i>)	<p>Returns whether specified channels are closed. 0: channel is open (not connected) 1: channel is closed (connected)</p> <p><i>channel_list</i>: Channels to check.</p>
[:ROUT]:CONN:RULE <i>card_number, rule</i>	<p>Sets the connection rule for the specified card.</p> <p><i>card_number</i>: For Auto Config mode: 0 or ALL For Normal Config mode: 1, 2, 3, 4, or ALL</p> <p><i>rule</i>: FREE: free route, or SROUte: single route</p>
[:ROUT]:CONN:RULE? <i>card_number</i>	<p>Returns the connection rule of the specified card: FREE: free route, SROU: single route</p> <p><i>card_number</i>: For Auto Config mode: 0 For Normal Config mode: 1, 2, 3, 4</p>
[:ROUT]:CONN:SEQ <i>card_number, sequence</i>	<p>Specifies the connection sequence mode for the specified card.</p> <p><i>card_number</i>: For Auto Config mode: 0 or ALL For Normal Config mode: 1, 2, 3, 4, or ALL</p> <p><i>sequence</i>: NSEQ: No-Sequence mode BBM: Break-Before-Make mode MBBR: Make-Before-Break mode</p>

SCPI Command Summary

Command	Description
<code>[:ROUT] : CONN : SEQ ? <i>card_number</i></code>	<p>Returns the connections sequence mode of the specified card:</p> <p>NSEQ: No-Sequence mode BBM: Break-Before-Make mode MBBR: Make-Before-Break mode.</p> <p><i>card_number</i>:</p> <p>For Auto Config mode: 0 For Normal Config mode: 1, 2, 3, 4</p>
<code>[:ROUT] : COUP : PORT <i>card_number</i>, '<i>couple_port</i>'</code>	<p>Sets up the couple ports for the specified card. Only for the E5252A card.</p> <p><i>card_number</i>:</p> <p>For Auto Config mode: 0 or ALL For Normal Config mode: 1, 2, 3, 4, or ALL</p> <p><i>couple_port</i>:</p> <p>One or more input port numbers: 1, 3, 5, 7, or 9. Enclose by single quotation marks. Separate multiple input port numbers by comma. For example: ' 1, 5 '</p>
<code>[:ROUT] : COUP : PORT ? <i>card_number</i></code>	<p>Returns the lower input port number of each couple pair on the specified card. Only for the E5252A card.</p> <p><i>card_number</i>:</p> <p>For Auto Config mode: 0 For Normal Config mode: 1, 2, 3, 4</p>
<code>[:ROUT] : COUP [: STAT] <i>card_number</i>, <i>state</i></code>	<p>Turns Couple Mode ON or OFF for the specified card. Only for the E5252A card.</p> <p><i>card_number</i>:</p> <p>For Auto Config mode: 0 or ALL For Normal Config mode: 1, 2, 3, 4, or ALL</p> <p><i>state</i>:</p> <p>ON or 1: turn ON Couple Mode OFF or 0: turn OFF Couple Mode</p>

Command	Description
[:ROUT] : COUP [:STAT] ? <i>card_number</i>	Returns Couple Mode of specified card. 0: Couple Mode is OFF 1: Couple Mode is ON. <i>card_number</i> : For Auto Config mode: 0 For Normal Config mode: 1, 2, 3, 4
[:ROUT] : FUNC <i>channel_config</i>	Sets the channel configuration mode. <i>channel_config</i> : ACON: Auto Config Mode NCON: Normal Config Mode
[:ROUT] : FUNC ?	Returns present channel configuration: ACON: Auto Config Mode NCON: Normal Config Mode
[:ROUT] : OPEN : CARD <i>card_number</i>	Disconnects all input ports from all output ports for specified card. <i>card_number</i> : For Auto Config mode: 0 or ALL For Normal Config mode: 1, 2, 3, 4, or ALL
[:ROUT] : OPEN [:LIST] (@ <i>channel_list</i>)	Disconnects the input ports from output ports as specified in <i>channel_list</i> . <i>channel_list</i> : Channels to open.
[:ROUT] : OPEN [:LIST] ? (@ <i>channel_list</i>)	Returns whether specified channels are opened. 0: channel is closed (connected) 1: channel is opened (disconnected) <i>channel_list</i> : Channels to check.
: SYST : CCON ? <i>card_number</i>	Returns the card configuration information: E5252A: no info returned. E5255A: input port and resistance info for each block. <i>card_number</i> : 1, 2, 3, or 4

SCPI Command Summary

Command	Description
:SYST:CDES? <i>card_number</i>	Returns a description of the specified card: model number and input/output port info. <i>card_number</i> : For Auto Config mode: 0 For Normal Config mode: 1, 2, 3, or 4
:SYST:CPON <i>card_number</i>	Resets the specified card to the power-on state. <i>card_number</i> : For Auto Config mode: 0 or ALL For Normal Config mode: 1, 2, 3, 4, or ALL
:SYST:CTYP? <i>card_number</i>	Returns ID of specified card: model number and revision. <i>card_number</i> : For Auto Config mode: 0 For Normal Config mode: 1, 2, 3, or 4
:SYST:ERR?	Reads error from head of error queue, and removes that error from queue.
:SYST:VERS?	Returns SCPI version number for which the E5250A complies.

Free Manuals Download Website

<http://myh66.com>

<http://usermanuals.us>

<http://www.somanuals.com>

<http://www.4manuals.cc>

<http://www.manual-lib.com>

<http://www.404manual.com>

<http://www.luxmanual.com>

<http://aubethermostatmanual.com>

Golf course search by state

<http://golfingnear.com>

Email search by domain

<http://emailbydomain.com>

Auto manuals search

<http://auto.somanuals.com>

TV manuals search

<http://tv.somanuals.com>