

LifeSpan™

EX3 elliptical

Owners Manual
Version 1.1



table of contents

	Page
Introduction	1
Specifications.	2
Limited Home Use Warranty	3
Important Safety Precautions	4
Find a Certified Health Fitness Instructor	5
Getting Fit	6
Assembly Instructions	8
Electronics Overview	10
Exercise Programs	11
Elliptical Operations	12
Troubleshooting	14

Congratulations on the purchase of your LifeSpan Home series exercise equipment. To ensure safe and trouble free operation, we suggest that you read this Owners Manual and follow its recommendations.

LifeSpan™ and Intelli-Key™ are trademarks of PCE Health and Fitness. Any use of these trademarks, without express written consent of PCE Health and Fitness is forbidden.

welcome to LifeSpan™

We all know that exercise is a key component to achieving the level of Health and Wellness that all of us desire. Regular activity prevents the development of numerous diseases, helps to reduce stress, leads to an improved self image, weight loss and increased energy levels.

The LifeSpan Home series offer the discriminating consumer products that meet their exacting needs and with many of the models we include commercial warranties that cover institutional use up to 6 hours per day. The requirement for performance and durability is at the heart of each PRO series model. We start with a robotically welded steel frame and add top of the line components to our patented EX-Link drive system. The result is a smooth and consistent workout for every user that will last for years to come.

To make the Home series easy to use we include our Intelli-Key™ blue button system that simply and easily steps each user through the program set-up process and for motivation we include resistance programs and a heart rate control program to give our customers the programming variety they need to maintain their workout routines.

Please read this manual thoroughly before assembly and operation of your LifeSpan elliptical. It includes basic information on starting an exercise program, and safety tips that will assist you in reaching your goals for a healthy lifestyle.

To keep your elliptical cross trainer in optimal condition, please pay attention to the maintenance and cleaning section of this manual and remember that some kinds of service should only be performed by a qualified service technician. If service is required, please contact your authorized PCE Health and Fitness Retailer. If a question or problem arises that cannot be answered by your retailer, contact us:

PCE Health and Fitness
PO Box 981316
Park City, Utah 84098 -1316
Phone: (801) 973-9993
Fax: (801) 973-9923
www.pcefitness.com

Neither PCE Health and Fitness nor its representatives can accept responsibility for any damage or injury incurred as a result of information presented in the manual except under the terms of the product warranty.

specifications



ELECTRONICS AND PROGRAMMING	CONSOLE	8 * 16 LED Program Matrix, 3 LED Display Panels, Storage Tray, and Spring Loaded Magazine Rack
	PROGRAMMING	Manual, Random, Mountain, Weight Loss, Target Heart Rate, Interval
	CONSOLE FEEDBACK	Time, Distance, Speed, Calories, Resistance Level, Heart Rate
	HEART RATE	Contact Hand Grips and Optional Chest Strap
	CONSOLE OPERATIONS	Intelli-Key™ blue light program setup and operations
	POWER	Plug-in (120 VAC to 6 VDC)
MECHANICS AND PERFORMANCE	20" STRIDE LENGTH	Patented EX-Link™ drive system provides a bio-mechanically correct symmetrical elliptical pattern that models your natural walking gait and places the pedals parallel to the ground at the bottom of the pedal stroke.
	DRIVE SYSTEM	Quiet-Stride drive system includes commercial grade sealed bearings and poly-V-belt with 10.5 to 1 flywheel to pulley ratio providing smooth resistance at all workout levels.
	LEVELS OF RESISTANCE	16 Levels
	RESISTANCE SYSTEM	Motor Operated Eddy Current Brake.
	ARM MOVEMENT	Multi-position handlebars include maximum movement up to 25" (64 cm).
	PEDALS	Oversized slip resistant 16.8"L / 7.4"W (42 cm L / 18.4 cm W)
	FLOOR SPACE	67"L / 29.2"W / 63"H (167 cm L / 66.7 cm W / 157.5 cm H)
	PRODUCT WEIGHT	213 lbs / 97 kg
	FRAME	Extra heavy duty welded frame with chrome plated running rails.
	MAX. USER WEIGHT	350 lbs / 159 kg
	FLOOR LEVELING	4 point adjustable foot pads
	TRANSPORT	Front mounted transport wheels offer easy moving.
RESIDENTIAL WARRANTY	FRAME	LifeTime
	PARTS	3 Years
	LABOR	1 Year

limited home use warranty

The LifeSpan EX3 comes with the following limited warranty, which applies only to the use of the cross trainer in the home, for residential, non-commercial purposes.

- Frame: Lifetime
- Parts: 3 year
- Labor: 1 year

PCE Health and Fitness warrants that the equipment it manufacturers is free from defects in material and workmanship under normal use and service. The periods above are based on the date of purchase. During these periods, PCE Health and Fitness will repair or replace any defective part. Free labor is included for the first year.

If within the time frames specified above, any part of the LifeSpan EX3 fails to operate properly contact your authorized PCE Health and Fitness retailer to report the problem. All labor shall be supplied by the authorized retailer that sold your product and the product must be located within that retailer's service area. If you are unable to reach the dealer that you purchased the product from, contact PCE Health and Fitness at our web site, www.pcefitness.com and click on Customer Support/Customer Service or call 801-973-9993.

PCE Health and Fitness reserves the right to make changes and improvements to our products without incurring any obligations to similarly alter any product purchased. In order to insure our product warranty and to ensure the safe and efficient operation of your elliptical, only authorized parts can be used. The warranty is void if any parts other than those provided by PCE Health and Fitness are used.

Exclusions and Limitations

- This warranty does not apply to any defects caused by negligence, misuse, improper assembly or maintenance, accident, or an "act of god".
- This warranty does not apply to discoloration of paint or plastics.
- PCE Health and Fitness shall not be responsible for incidental or consequential damages.
- This warranty is nontransferable from the original owner.

Registration

You must register your LifeSpan product before a warranty claim can be processed. To complete your registration card online, go to www.pcefitness.com and fill out the registration card online or fill out the warranty card provided with your elliptical and mail it today. Registration Cards must be completed and sent to PCE Fitness within 30 days of purchase to activate the Product Warranty on your LifeSpan equipment. Product Warranties are not valid unless properly completed and sent to PCE Fitness within this 30 day period.

Note: Read ALL instructions before using your LifeSpan elliptical.

important safety precautions

When using equipment, basic precautions should always be followed, including:

- Never drop or insert any object into any opening.
- Never operate your elliptical cross trainer if it has been damaged or even partially submersed in water.
- Do not use outdoors, near swimming pools or in areas of high humidity.
- Keep the elliptical cross trainer on a solid, level surface.
- Use this exercise product for its intended use as described in this Owners Manual.
- Do not use attachments that are not recommended by PCE Health and Fitness.
- Wear shoes with rubber or high traction soles.
Do not use shoes with heels, leather soles, cleats or spikes.
- Keep hands and feet away from all moving parts.

Children and Pets

- Keep children off your elliptical at all times.
- When in use, young children and pets should be kept at least 10 feet away.

Other Safety Tips

- Always consult a physician before beginning this or any exercise program.
- If you experience chest pains, nausea, dizziness or shortness of breath, stop exercising immediately and consult your physician before continuing.

find a certified health fitness instructor

Everyone is unique. We all have different physical characteristics, medical backgrounds, and daily patterns that need to be considered to design the optimal workout and nutrition program. The Getting Fit section of your Owners Manual is designed to give you a brief overview that will be beneficial in starting or modifying your exercise program. We recommend however, that you consider using a certified fitness professional that is trained to tailor a fitness program specifically for you.

To support this, we have partnered with the American College of Sports Medicine (ACSM). The ACSM has certified Personal Trainers and Health Fitness Instructors that can assist you in getting started and in maintaining the right exercise program for you.

getting fit

Cardiovascular endurance is the most important component of physical fitness. There are two types of cardiovascular training, these are interval training and steady state training.

Interval training varies the amount of effort required to workout. The LifeSpan EX3 comes with several programs that automatically vary the amount of resistance during the course of the workout. These include Interval, Random, Mountain and Weight Loss programs. All of these programs vary the amount of effort required during the workout by automatically adjusting the flywheel resistance.

Steady state training keeps the workload constant. The manual program on your LifeSpan elliptical allows you to manually control the resistance of your elliptical providing you with a constant workout that you completely control. The EX3 also supports Heart Rate training where you can preset the elliptical to a target heart rate. The elliptical will then automatically adjust the resistance level to maintain your target heart rate

If you have a requirement to maintain a steady heart rate during your workout, the manual or Target Heart Rate Program is the best selection.

Regardless of your personal fitness goals and the program that you pursue, warming up and cooling down before and after you workout will help reduce the risk of injury and improve the effectiveness of your workout.

Warming up is important to bring your body from its normal level of activity to a state where it is ready to exercise by increasing the flow of blood to the muscle to raise the muscle temperature. This will increase the muscle elasticity and protect the joints. The warm up period also helps to mentally prepare you for your workout.

Warmups should be done at a low intensity level and last for at least five minutes.

Cooling down after your workout is required to gradually bring your cardiovascular system down to its normal level.

Follow your workout with at least 10 minutes of stretching. Focus on the major muscle groups of the lower extremity. When stretching, stretch the muscle until you feel gentle tension, hold it and wait for the tension to relax while the muscle elongates, stretch the muscle again until you feel gentle tension.

Do not bounce when you stretch, bouncing is not an effective approach to stretching and can lead to injury.

The three components of a successful cardiovascular exercise program are:

- Frequency
- Intensity
- Time

In terms of **frequency**, you should try and exercise at least three times per week. Preferably you should try to exercise every other day to give your body a days rest in-between workouts.

The **intensity** of each workout refers to how hard you feel you are working and can be measured by your heart rate. Depending on your fitness goals, exercise between 55% and 90% of your maximum heart rate. A simple way of estimating your maximum heart rate is by subtracting your age from 220. As a general rule of thumb, if your fitness objective is to lose weight, you will want to keep your heart rate at between 60% and 75% of your maximum heart rate. If your objective is improved aerobic performance keep your heart rate between 75% and 85% of your maximum heart rate.

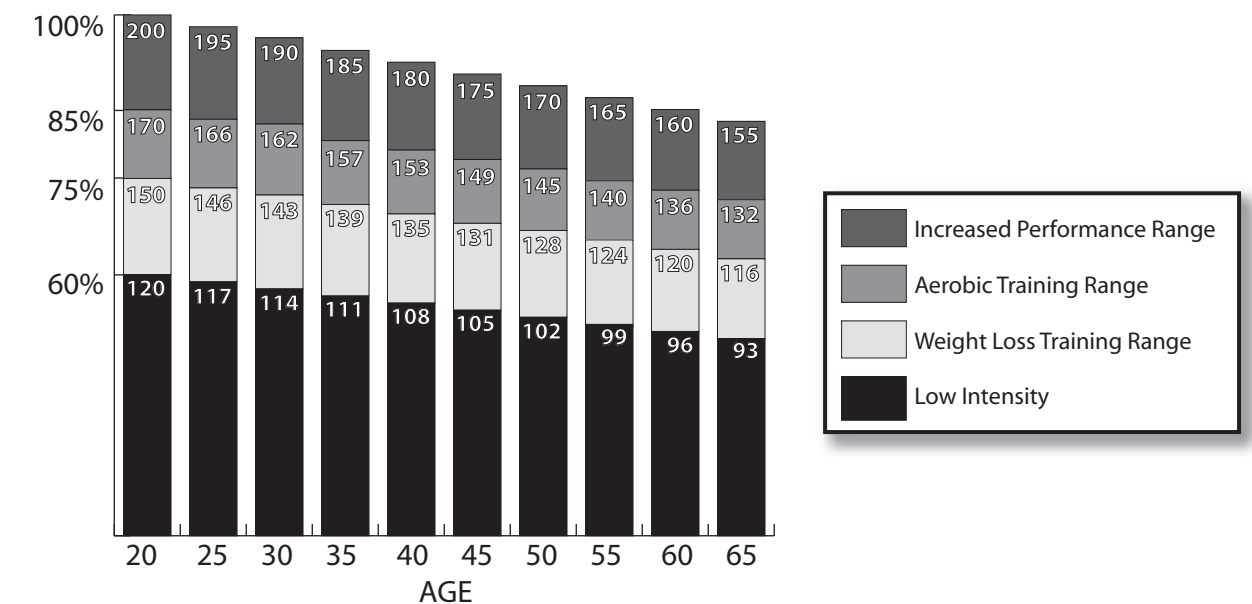

To achieve benefits from your workout, your workout **time** should be at least 20 minutes per session. If you are trying to lose weight focus on longer (45 - 60 minutes) less intense workouts, to improve your aerobic performance focus on shorter more intense workouts.

As a rule of thumb when your exercising, if you are having trouble completing a sentence, you are working too hard. When exercising, you should be able to speak freely without gasping for air.

assembly instructions

Since your elliptical cross trainer is a heavy piece of equipment, we recommend that you use 2 people during assembly.

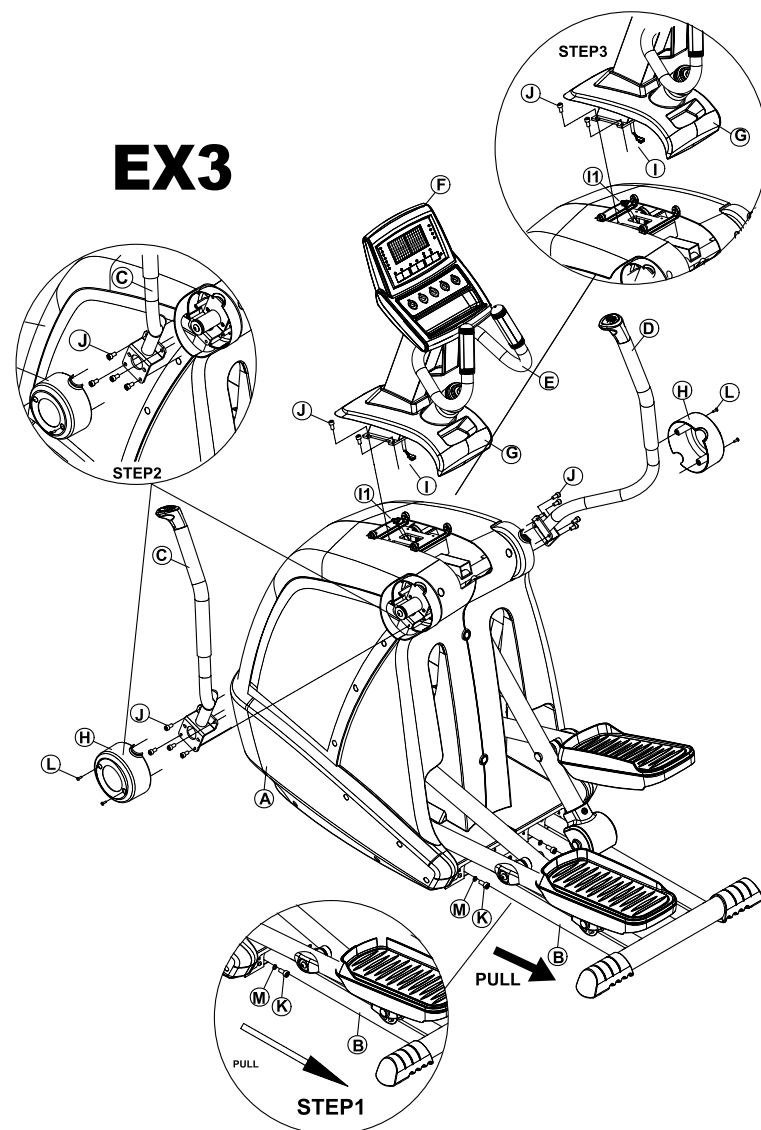

HARDWARE-TOOLS

Screws Already in Place on the Elliptical

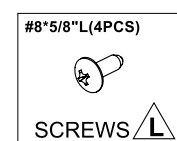
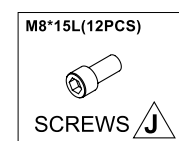

Hardware Bag

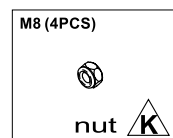
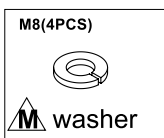
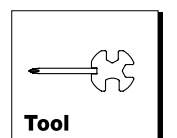
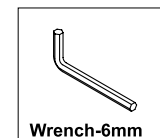

STEP 1: Secure Frame (See Figures 1 & 2)

- Place the cross trainer on the floor in a level area. Pull out the chrome plated rails by grabbing the back of the rails, by the rear feet, and pulling the rear feet away from the frame. The rails need to be fully extended in the length before the nuts can be attached.

Note: These rails pushed into the frame to reduce the shipping size.

- Secure the rails in place using the 4 Nuts (K) with Lock Washers (M) included in the hardware bag.
- Tighten the 4 Nuts (K) with Lock Washers (M) using the provided wrench.

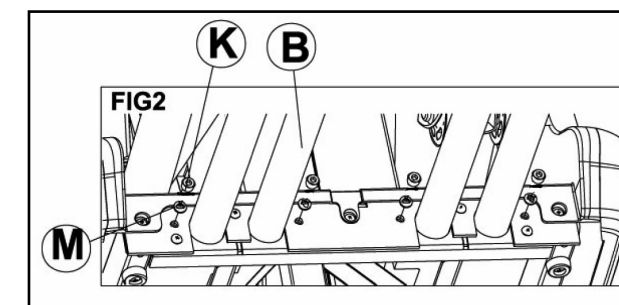
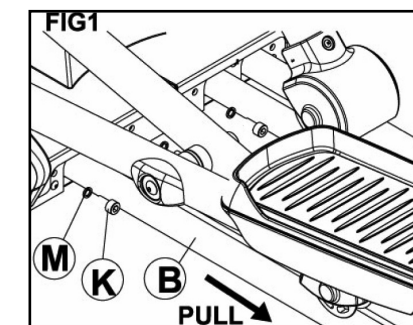

STEP 2: Attach Handlebars (See Figure 3)

- Attach both the right and left handlebars by first removing the four attaching screws (J) already in place on the frame brackets where the handlebars are mounted. Place the handlebar bracket over the top of the frame bracket and align the 4 holes. Hand tighten each of the 4 screws (J) first before tightening with the provided 6 mm Allen wrench.
- Attach the round plastic outside handlebar covers by first removing the screws (L) that are hand tightened on the inner round cover. Place the outer cover over the inner cover, aligning the holes, and install and tighten the 2 screws (L) with a Phillips head screw driver.

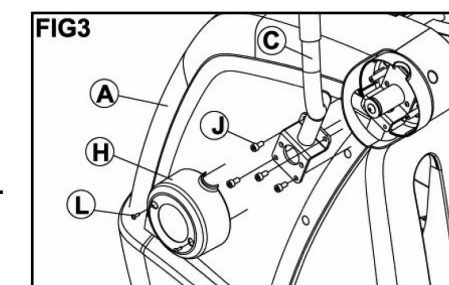

STEP 3: Attach the Display Console Frame (See Figure 4)

- Remove the 4 screws (J) hand tightened into the top of the console mount bracket. With the help of a 2nd person connect the the connector between the main frame and the display console frame.
- Align the Display Console Frame over the Main Frame bracket being careful not to pinch the wire harness between the 2 frames. Install and hand tighten the 4 attaching screws (J) before fully tightening with the supplied 6 mm Allen wrench.

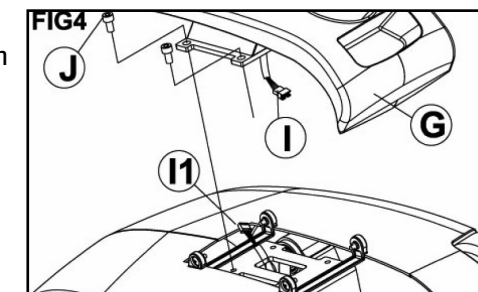

electronics overview

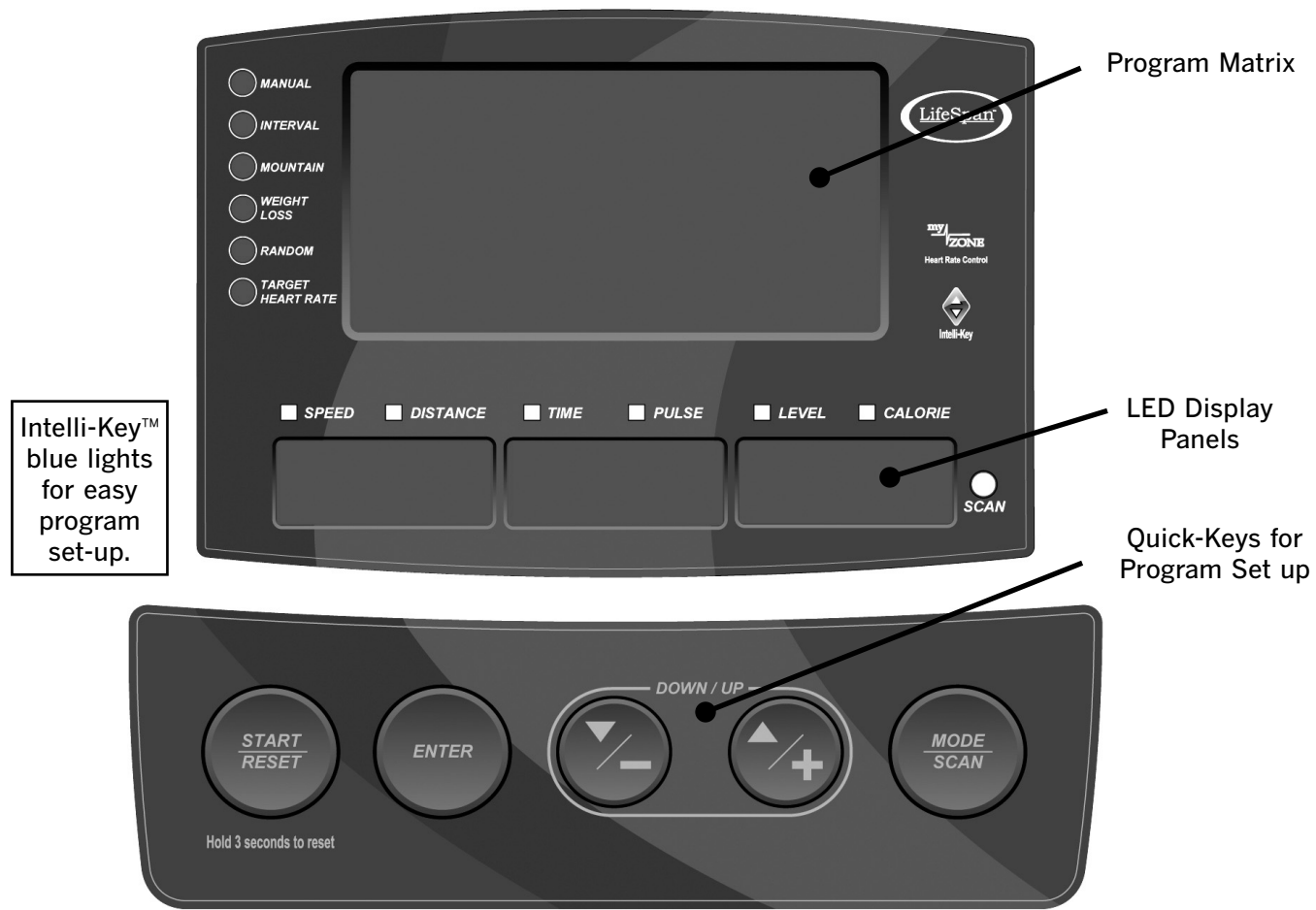

- Display console includes the **Intelli-Key™** blue lights. The flashing blue light shows you which button to press next to set-up and use the system programs.
- The Resistance Level **+** and **-** buttons allow the user to set up the programs as well as change resistance levels while in use.
- The **Start/Reset** button allows you to begin your workout in manual mode without going through the set up process.
- **Heart Rate** readout supports using a Polar Compatible Chest Strap.
- The **Scan** button is used to either select a specific set of readouts like – Speed, Time and Level or Distance, Heart Rate and Calories or it can be used to automatically switch between these two sets of readouts. The Scan light will turn on when the readouts are set to automatically switch between the readouts.

exercise programs

The EX3 comes with a manual program, where the user controls the pedal resistance and with Interval, Weight Loss, Mountain, and Random programs that automatically vary the resistance during the course of the workout. In addition there is a Heart Rate Program that automatically varies the resistance based on keeping your heart rate at the level that you originally selected.

Program time can be preset to range from 10:00 minutes to 99:00 minutes or you can just start counting up from 00:00. If the time is preset, the program length will be divided into 16 equal segments. If the program counts up from 00:00, each segment will run for 60 seconds. After 16 minutes the program profile will go back to the beginning automatically.

Interval

Segments	1	2	3	4	5	6	7	8	9	10	11	12	13	14	15	16
Level 1	2	3	2	7	7	2	2	7	7	2	2	7	7	2	3	2
Level 2	3	4	3	8	8	3	3	8	8	3	3	8	8	3	4	3
Level 3	4	5	4	9	9	4	4	9	9	4	4	9	9	4	5	4

Mountain

Segments	1	2	3	4	5	6	7	8	9	10	11	12	13	14	15	16
Level 1	3	3	5	5	7	9	9	11	13	11	9	7	5	5	3	3
Level 2	4	4	6	6	8	10	10	12	14	12	10	8	6	6	4	4
Level 3	5	5	7	7	9	11	11	13	15	13	11	9	7	7	5	5

Weight Loss

Segments	1	2	3	4	5	6	7	8	9	10	11	12	13	14	15	16
Level 1	2	2	4	6	4	4	4	6	4	4	4	6	4	2	2	2
Level 2	3	3	5	7	5	5	5	7	5	5	5	7	5	3	3	3
Level 3	4	4	6	8	6	6	6	8	6	6	6	8	6	4	4	4

Random

Segments	1	2	3	4	5	6	7	8	9	10	11	12	13	14	15	16
Level 1	4	6	2	10	8	4	12	8	4	6	2	6	12	12	4	4
Level 2	5	7	3	11	9	5	13	9	5	7	3	7	13	13	5	5
Level 3	6	8	4	12	10	6	14	10	6	8	4	8	14	14	6	6

elliptical operations

Before using your Elliptical Cross Trainer make sure that it sits level on the floor. Adjust the feet in the front corners first to make sure that the body of the machine sits level on the floor. Then adjust the 2 rear feet up to make sure that all 6 feet sit level on the floor.

When you begin, the Intelli-Key lights on the Resistance + and – buttons should be flashing and the Start/Reset button should be illuminated. Remember that the Intelli-Key button system will always flash the next button that needs to be pressed. If you make a selection and don't know which button to press next, wait for 3 seconds and the correct button will begin to flash.

Quickstart

The easiest way to begin a workout on your Elliptical is to press the Start/Reset button and begin working out in manual mode. In this case the console will begin counting up from 00:00. If you want to preset the workout time in manual mode simply press the Resistance + button and press Enter. The time display reads 00:00. Press the Resistance + or - buttons to set the time and press start. The time will count down from the preset time.

Checking Your Heart Rate

You can check your heart rate by placing your hands on the bullhorn Contact Pulse Grips. Holding onto the contact pulse grips for 30 or more seconds will give a more accurate reading. If the contact pulse grips cannot pick up your pulse accurately or at all, we recommend that you warm up for 5 to 10 minutes or until you begin to perspire to get a more accurate reading. You can also use Aloe Vera on your hands for better conductivity between your hands and the contact pulse grips.



Using your (Optional) chest strap and the heart rate receiver built into the console is the preferred method to get an accurate heart rate reading, particularly when using the heart rate control program. When putting your chest strap on, adjust the transmitter portion to the left side of your chest, right over your heart. It may take a few minutes for your skin to moisten and improve the contact between your skin and the chest strap. If you are experiencing trouble getting a heart rate reading, make slight adjustments to the position of the chest strap and check the batteries.

Optional Chest Strap can be purchased online at www.pcefitness.com.

Resistance Program Set-up (Interval, Mountain, Weight Loss, Random)

The EX3 comes with the LifeSpan Intelli-Key button system that simply and easily steps you through the program set-up process.

1. **Select Program:** Press the Resistance + or – buttons to scroll through each program. The LED light next to the program name will illuminate to highlight which program is selected and the program matrix will show the program profile. Press “Enter” when you reach the desired program.
2. **Select Level:** Use the Resistance + or – buttons to select between levels.
3. **Set Time:** Set the workout time. The time starts at 24:00 minutes. Use the Resistance + or – buttons to adjust the time from here. Once the time is set press the “Start/Reset” button to begin your workout.

Heart Rate Control Program Set-up

The Heart Rate Control program automatically changes the resistance to maintain a constant heart rate that you establish during the program set up process.

1. **Select Program:** Press the Resistance + or – buttons until the Red LED illuminates beside the Target Heart Rate program. Press “Enter”.
2. **Set Time:** Use the Resistance + or – buttons to select the workout time. If a time is not selected, the program will start counting up from 00:00. Press “Enter”.
3. **Set Target Heart Rate:** Set the desired workout heart rate by using the Resistance + or – buttons and Press the “Start” button to begin the workout.

troubleshooting & Maintenance

Troubleshooting

Problem: Unit is unstable or rocks while in use.

Solution: Make sure unit is on a solid, level surface. Adjust the front and rear adjustment feet until all 6 feet are sitting solid on the floor.

Problem: No power at console.

Solution: Try using another outlet or testing something else at the outlet being used to make sure there is power at the outlet. If still a problem contact LifeSpan Customer Service.

Problem: Rough feeling in pedals when in use.

Solution: Clean the rails with a dry cloth. Any debris on the rails will give a rough feeling when in use.

Problem: Excess play in the handlebars or pedals.

Solution: Using the provided assembly tools, go over the Elliptical to make sure all assembly hardware is tight.

General Maintenance

1. Keep the unit clean and dry. It is a good idea to wipe the unit down after each workout to keep it clean.
2. Some material from the Roller Wheels will come off and leave deposits on the rails, this is normal. With a dry towel wipe the rails down as needed. Any debris on the rails can create a rough feeling in the pedals.
3. If the unit is not going to be used for any extended period of time it is a good idea to unplug the unit and store in a clean environment.



801-973-9993
www.pcefitness.com

P.O. Box 981316
Park City, Utah 84098-1316

Free Manuals Download Website

<http://myh66.com>

<http://usermanuals.us>

<http://www.somanuals.com>

<http://www.4manuals.cc>

<http://www.manual-lib.com>

<http://www.404manual.com>

<http://www.luxmanual.com>

<http://aubethermostatmanual.com>

Golf course search by state

<http://golfingnear.com>

Email search by domain

<http://emailbydomain.com>

Auto manuals search

<http://auto.somanuals.com>

TV manuals search

<http://tv.somanuals.com>