



ESU 120e

User Manual

Part Number
1200420L1-1

November 1998
61200420L1-1A

Trademarks:

Windows is a registered trademark of Microsoft Corp.

T-Watch is a trademark of ADTRAN, Inc.



901 Explorer Boulevard
P.O. Box 140000
Huntsville, AL 35814-4000
Phone: (256) 963-8000

© 1998 ADTRAN, Inc.
All rights reserved.
Printed in USA.

ADTRAN Year 2000 (Y2K) Readiness Disclosure

ADTRAN has established a Year 2000 program to ensure that our products will correctly function in the new millennium. ADTRAN warrants that all products meet Y2K specifications regardless of model or revision.

Information about ADTRAN's Y2K compliance program is available at the following locations:

ADTRAN Web Site	www.adtran.com
Product Matrix	www.adtran.com/y2kfax.html
Faxback Document Line	(256) 963-8200
	<i>Y2K plans and product certifications are listed in the matrix.</i>
Y2K Project Line	(256) 963-2200
E-mail	year2000@adtran.com

FEDERAL COMMUNICATIONS COMMISSION RADIO FREQUENCY INTERFERENCE STATEMENT

This equipment has been tested and found to comply with the limits for a Class A digital device, pursuant to Part 15 of the FCC Rules. These limits are designed to provide reasonable protection against harmful interference when the equipment is operated in a commercial environment. This equipment generates, uses, and can radiate radio frequency energy and, if not installed and used in accordance with the instruction manual, may cause harmful interference to radio frequencies. Operation of this equipment in a residential area is likely to cause harmful interference in which case the user will be required to correct the interference at his own expense.

Shielded cables must be used with this unit to ensure compliance with Class A FCC limits.

WARNING

Changes or modifications to this unit not expressly approved by the party responsible for compliance could void the user's authority to operate the equipment.

CANADIAN EMISSIONS REQUIREMENTS

This digital apparatus does not exceed the Class A limits for radio noise emissions from digital apparatus as set out in the interference-causing equipment standard entitled "Digital Apparatus," ICES-003 of the Department of Communications.

Cet appareil numérique respecte les limites de bruits radioélectriques applicables aux appareils numériques de Class A prescrites dans la norme sur le matériel brouilleur: "Appareils Numériques," NMB-003 édictée par le ministre des Communications.

CANADIAN EQUIPMENT LIMITATIONS

WARNING

The Industry Canada Certification label identifies certified equipment. This certification means that the equipment meets certain telecommunications network protective, operational, and safety requirements. The Department does not guarantee the equipment will operate to the user's satisfaction.

Before installing this equipment, users should ensure that it is permissible to be connected to the facilities of the local telecommunications company. The equipment must also be installed using an acceptable method of connection. In some cases, the company's inside wiring associated with a single line individual service may be extended by means of a certified connector assembly (telephone extension cord). The customer should be aware that compliance with the above conditions may not prevent degradation of service in some situations.

Repairs to certified equipment should be made by an authorized Canadian maintenance facility designated by the supplier. Any repairs or alterations made by the user to this equipment, or equipment malfunctions, may give the telecommunications company cause to request the user to disconnect the equipment.

Users should ensure for their own protection that the electrical ground connections of the power utility, telephone lines and internal metallic waterpipe system, if present, are connected together. This precaution may be particularly important in rural areas.



NOTE

Users should not attempt to make such connections themselves, but should contact the appropriate electric inspection authority, or an electrician, as appropriate.

The Load Number (LN) assigned to each terminal device denotes the percentage of the total load to be connected to a telephone loop which is used by the device, to prevent overloading. The termination on a loop may consist of any combination of devices subject only to the equipment that the total of the LNs of all devices does not exceed 100.

The ringer equivalence number (REN) assigned to each terminal adapter is used to determine the total number of devices that may be connected to each circuit. The sum of the RENs from all devices in the circuit should not exceed a total of 5.0.



Notes provide additional useful information.



Cautions signify information that could prevent service interruption.



Warnings provide information that could prevent damage to the equipment or endangerment to human life.

Important Safety Instructions

When using your telephone equipment, please follow these basic safety precautions to reduce the risk of fire, electrical shock, or personal injury:

1. Do not use this product near water, such as near a bath tub, wash bowl, kitchen sink, laundry tub, in a wet basement, or near a swimming pool.
2. Avoid using a telephone (other than a cordless-type) during an electrical storm. There is a remote risk of shock from lightning.
3. Do not use the telephone report a gas leak in the vicinity of the leak.
4. Use only the power cord, power supply, and/or batteries indicated in the manual. Do not dispose of batteries in a fire. They may explode. Check with local codes for special disposal instructions.

SAVE THESE INSTRUCTIONS

Warranty and Customer Service

ADTRAN will replace or repair this product within five years from the date of shipment if the product does not meet its published specifications or if it fails while in service. For detailed warranty, repair, and return information refer to the ADTRAN Equipment Warranty and Repair and Return Policy Procedure.

Return Material Authorization (RMA) is required prior to returning equipment to ADTRAN.

For Service, RMA requests, or more information, contact ADTRAN Customer Service listed on the inside back cover of this manual.

Table of Contents

Table of Contents	xi
List of Figures.....	xvii
List of Tables.....	xix
Chapter 1 Introduction.....	1-1
ESU 120e Overview	1-1
ESU 120e Features	1-2
ESU Option Modules	1-2
Option Module Architecture	1-3
ESU 120e Configuration Applications	1-3
Router, PBX Application	1-3
Chapter 2 Installation.....	2-1
Unpack, Inspect, Power Up	2-1
Receipt Inspection	2-1
ADTRAN Shipments Include	2-1
Customer Provides	2-1
Power Connection	2-2
Grounding Instructions	2-2
Identification of Rear Panel Layout	2-4
ESU120e Interfaces	2-5
Network Interfaces	2-5
Network Test Interface	2-5
Nx56/64 Serial Interface	2-5
Drop (PBX) Interface	2-6
Control Port Input	2-6
Chain Port Output	2-6
10BaseT Interface	2-6
Power-Up Testing	2-6
Self-Test	2-6
Initialization	2-7

Table of Contents

Set User Passcode	2-7
Set Unit Identification	2-7
Set Control Port	2-8
Chain In (PC)	2-8
Chain In/Chain Out	2-8
Normal Power-Up Procedure	2-9
Chapter 3 Operation	3-1
Front Panel	3-1
LED Descriptions	3-3
CSU Status	3-3
DSU/Drop Status	3-3
Module Status	3-4
Operation keys	3-4
General Menu Operation	3-5
Select and Activate a Menu Item	3-5
Set the Data Field	3-6
Exit Any Menu Field Operation Or Display	3-7
Data Port Identification	3-7
Front Panel Menu Structure	3-7
Alternate Methods of Control	3-8
T-Watch PRO (ADTRAN PC Program)	3-8
SNMP	3-10
Terminal Mode	3-10
Telnet	3-10
Chapter 4 Status Menu.....	4-1
Network Interface Performance Reports (NI PERF RPTS)	4-2
Network Interface Errors (NI ERRORS)	4-3
Active Alarms	4-3
View History	4-4
Port Status	4-5
0.1 Nx56/64 Menu Items	4-5
DTE Data/CK	4-5
DTE Status	4-5
Port Rate	4-5
0.2 Drop Menu Items (DSX Errors)	4-6
Remote Port	4-6
Clear Port Alarm	4-6
ENET Status	4-6

Chapter 5	Configuration Menu.....	5-1
Network (NI)		5-3
Network (NI) Menu Items		5-3
ESU 120e Clock Sources		5-5
Network Timed		5-6
Base Drop Timed		5-7
Base DTE Timed		5-8
Internal Timing		5-9
Normal (CSU) Timing		5-10
Unit Menu		5-11
Map Exchange (Map Xchng)		5-13
Map In Use: A(B)		5-13
TS0 Map A and TS0 Map B		5-14
Port Configuration (Port Config)		5-17
0.1 Nx56/64 Port Configuration (Port Config) Menu Items		5-17
0.2 Drop Port Configuration (Port Config) Menu Items		5-19
Chapter 6	Utility Menu.....	6-1
Time/Date		6-2
Factory Restore		6-2
Set Passcode		6-2
Enter Passcode from Other Menus		6-2
Change/Set a Passcode		6-3
Special Feature		6-3
No Passcode Desired		6-3
Unit ID		6-4
To Set the Unit Identification		6-4
No Unit ID Desired		6-4
Software Revision (Software Rev)		6-4
Port Utility		6-5
Enet Address		6-5
CMD Mode		6-5
Chapter 7	Test Menu.....	7-1
Network Tests		7-2
Loopback Tests		7-2
Network Interface Loopbacks		7-2
LOCAL LOOPBCK		7-3
REMOTE LOOPBCK		7-3
TEST PATTERN		7-3
All Ones		7-3

Table of Contents

All Zeros	7-3
QRSS Pattern	7-4
PATTERN RESULT	7-5
Run Self-Test	7-6
Port Tests	7-7
Port Test Menu Items for 0.1 Nx56/64	7-8
LOOPBK	7-8
511 PATT	7-8
DIS 511 RESLT	7-8
Port Test Menu Items for 0.2 Drop	7-9
Loopback	7-9
Cancel Tests	7-9
Chapter 8 Telnet/Terminal Menus	8-1
Main Menu	8-1
TS0 Maps Configuration Menu	8-2
Initializing the Temp Map	8-3
Editing the Temp Map	8-3
Applying the Temp Map	8-3
Reviewing Temp Maps	8-3
Remote Menu Access	8-4
Management Configuration	8-4
SNMP Read Community	8-4
SNMP Read/Write Community	8-4
SNMP Trap Community	8-5
Host 1 Trap IP Address	8-5
Host 2 Trap IP Address	8-5
Host 3 Trap IP Address	8-5
Host 4 Trap IP Address	8-5
System Name	8-5
System Contact	8-5
System Location	8-5
Auth. Fail Traps Sent	8-6
Poll Link Status Traps Sent	8-6
Ping IP Host	8-6
Telnet/Terminal Timeout	8-6
Telnet/Terminal Password	8-6
Exit	8-6
Flash Download	8-7
Quit Session	8-7

Appendix A. Understanding SNMP	A-1
Appendix B. Connector Pinouts	B-1
Appendix C. System Messages	C-1
Appendix D. Specifications	D-1
Index	Index-1

List of Figures

Figure 1-1. Router, PBX, Application Set Up	1-3
Figure 2-1. ESU 120e Rear Panel	2-4
Figure 2-2. ESU 120e Interfaces	2-5
Figure 2-3. Example of Chain In	2-8
Figure 3-1. ESU 120e Front Panel Layout	3-2
Figure 3-2. Example of Basic Front Panel Menu Travel	3-6
Figure 4-1. Status Menu Tree	4-1
Figure 4-2. Network Interface Performance Report	4-2
Figure 4-3. Display of Alarm Messages	4-4
Figure 5-1. Configuration Menu Tree	5-2
Figure 5-2. Network Timed Clock Source	5-6
Figure 5-3. Drop Timed Clock Source	5-7
Figure 5-4. Network Timed Clock Source	5-8
Figure 5-5. Internal Clock Source	5-9
Figure 5-6. Normal (CSU)	5-10
Figure 5-7. DS0 Map Designations	5-14
Figure 5-8. Create Temp Selection Screen	5-15
Figure 6-1. Utility Menu Tree	6-1
Figure 7-1. Test Menu Tree	7-1
Figure 7-2. Network Loopback Tests	7-3
Figure 8-1. Telnet/Terminal Main Menu	8-1
Figure 8-2. TS0 Temp Map	8-2

List of Tables

Table 5-1.	Normal Mode of Operation	5-19
Table B-1.	Network Pinouts	B-1
Table B-2.	Control In/Chain-in Pinout	B-2
Table B-3.	Chain-Out Connector Pinout	B-3
Table B-4.	Nx56/64 Pin Assignments for EIA-530 and V.36	B-4
Table B-5.	Nx56/64 Pin Assignments for V.35 Mode	B-5
Table B-6.	Adapter Cable, DB 25 to V.35, 34-Pin Winchester	B-6
Table B-7.	Nx56/64 Pin Assignments for V.11/x.21 Mode	B-7
Table B-8.	Adapter Cable DB25 to X.21, DB15 Connector	B-8
Table B-9.	Pinout Connectors for Terminal Interface	B-8
Table B-10.	10BaseT Pinout	B-9

ESU 120E OVERVIEW

The ESU 120e is an E1/FE1 multiplexer with an Nx56/64 data port, a drop (PBX) interface, one option slot, and embedded SNMP management. The ESU 120e's option slot accepts one of many available option modules for voice and data applications.

The ESU 120e serves as the link between user data sources such as local area network (LAN) bridges and routers, computers, CAD systems, teleconferencing equipment, and PBXs. Through the use of multiple data ports, the ESU 120e can simultaneously connect one or more of these devices to a E1 circuit. The amount of bandwidth allocated to each port is custom-programmable. You can manually allocate bandwidth or set the bandwidth to automatically change at predetermined times to use the available bandwidth most advantageously. Changes in the configuration do not disrupt data flow in channels that are not being reconfigured. The unique architecture and the availability of option modules provides a path for growth to accommodate future requirements.

The ESU 120e offers a wide variety of network management options. You can manage via SNMP through the 10BaseT or chain-in ports. If you are using T-Watch Pro, a Microsoft Windows® program, you can manage the ESU 120e via the same 10BaseT or chain-in ports. An enhanced VT-100 terminal interface is also provided.

ESU 120e Features

The following list describes the standard features in the ESU 120e.

- A single E1 interface
- An Nx56/64 data port and G.703 drop port interface
- Data port supports V.35, EIA-530, V.36 and X.21 electrical interfaces
- An inband communication channel requiring only 8k of bandwidth from a single TS0
- One option slot to house option modules with up to four additional ports, including voice and data
- Allows mix of port types to meet the data interface requirements.
- Easy configuration capabilities using simplistic menus displayed in a liquid crystal display (LCD) window operated by a front panel keypad
- Two programmable configuration maps that define the bandwidth allocation between data ports
- Flash memory for software updates
- Selectable timing from the network, from the Nx56/64 or drop ports, internally, or from a secondary interface
- QRSS; 511 test patterns using Nx option
- Extensive self-test and monitoring provides assurance of proper operation
- SNMP, Telnet, and T-Watch Pro Management via SLIP or 10BaseT

ESU Option Modules

Some of the option modules available for the ESU 120e are:

- Nx56/64 serial interface. This module provides a V.35 serial interface in either single or dual versions.
- Router module. Integrated IP/IPX Router with 10BaseT interface.
- NxIQ. Provides extensive frame relay and monitoring capabilities.

Option Module Architecture

The ESU 120e features a unique architecture that allows the addition of one option module and plug-on board providing an opportunity for growth to accommodate another application.

ESU 120E CONFIGURATION APPLICATIONS

The following examples illustrate possible configurations of ESU 120e applications.

Router, PBX Application

In this application, the base Nx54/64 provides a V.35 interface to a router. The PBX is interfaced to the ESU 120e with the base drop interface. The 10BaseT port allows SNMP network management over the LAN. See Figure 1-1.

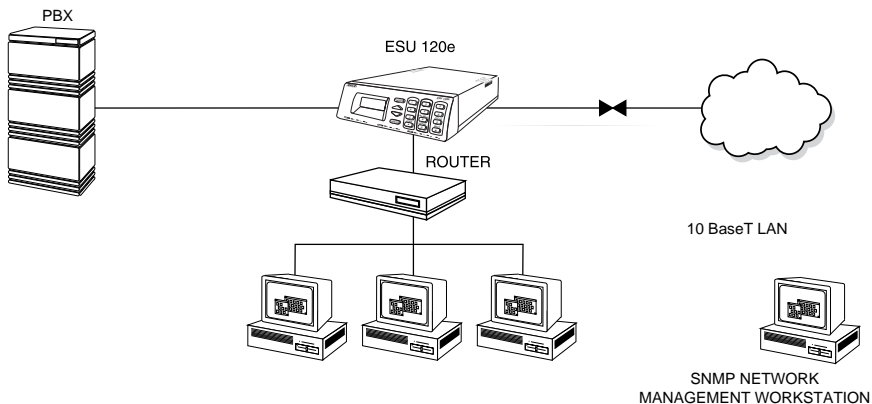

Figure 1-1. Router, PBX, Application Set Up

UNPACK, INSPECT, POWER UP

Receipt Inspection

Carefully inspect the ESU 120e for any shipping damages. If you suspect damage, file a claim immediately with the carrier and then contact ADTRAN Customer Service (see inside the last page of this manual). If possible, keep the original shipping container for use in shipping the ESU 120e back for repair or for verification of damage during shipment.

ADTRAN Shipments Include

- The ESU 120e
- A DB-25 to modular adapter for VT-100 and T-Watch access.
- An 8-position modular cable for connection to the chain-in port (6 ft.)
- The user manual

Customer Provides

- Power cord
- Cable(s) for connection to either the 120 Ω DB15 or 75 Ω BNC network interfaces
- Cables for any expansion modules to be used with the ESU 120e
- 10BaseT cable for connection to a LAN or router (if you plan to use remote management features)

Power Connection

Power is supplied to the ESU 120e through a IEC-type power connector on the rear of the unit.



Power to the ESU 120e must be from a grounded 90-240 VAC, 50/60Hz source.

GROUNDING INSTRUCTIONS

Grounding instruction information from the *Underwriters' Laboratory UL 1950 3rd Edition* is provided in this section.

An equipment grounding conductor that is not smaller in size than the ungrounded branch-circuit supply conductors is to be installed as part of the circuit that supplies the product or system. Bare, covered, or insulated grounding conductors are acceptable. Individually covered or insulated equipment grounding conductors shall have a continuous outer finish that is either green, or green with one or more yellow stripes. The equipment grounding conductor is to be connected to ground at the service equipment.

The attachment-plug receptacles in the vicinity of the product or system are all to be of a grounding type, and the equipment grounding conductors serving these receptacles are to be connected to earth ground at the service equipment.

A supplementary equipment grounding conductor shall be installed between the product or system and ground that is in addition to the equipment grounding conductor in the power supply cord.

The supplementary equipment grounding conductor shall not be smaller in size than the ungrounded branch-circuit supply conductors. The supplementary equipment grounding conductor shall be connected to the product at the terminal provided, and shall be connected to ground in a manner that will retain the ground connection when the product is unplugged from the receptacle. The connection to ground of the supplementary equipment grounding conductor shall be in compliance with the rules for terminating bonding jumpers at Part K or Article 250 of the National Electrical

Code, ANSI/NFPA 70. Termination of the supplementary equipment grounding conductor is permitted to be made to building steel, to a metal electrical raceway system, or to any grounded item that is permanently and reliably connected to the electrical service equipment ground.

Bare, covered, or insulated grounding conductors are acceptable. A covered or insulated grounding conductor shall have a continuous outer finish that is either green, or green with one or more yellow stripes.

The supplemental grounding conductor shall be connected to the equipment using a number 8 ring terminal. The terminal should be fastened to the grounding lug provided on the rear panel of the equipment. The ring terminal should be installed using the appropriate crimping tool (AMP P/N 59250 T-EAD Crimping Tool or equivalent).

IDENTIFICATION OF REAR PANEL LAYOUT

Figure 2-1 shows the configuration of the rear panel of the ESU 120e.

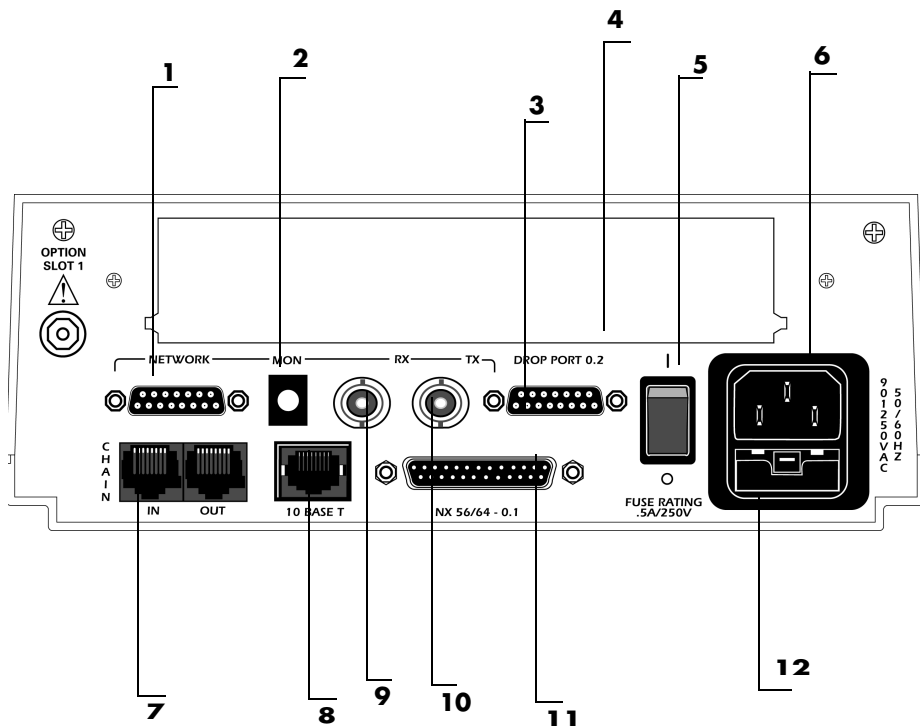

- | | |
|--------------------------------|---|
| 1 Network 120 Ω Connector | 7 Control In/Out Connection |
| 2 Network Receive Monitor Jack | 8 10BaseT Connector (To LAN for Management) |
| 3 Drop Port Connector (To PBX) | 9 Network 75 Ω Receive Connector |
| 4 Option Slot | 10 Network 75 Ω Transmit Connector |
| 5 Power Switch | 11 Data Port Connector |
| 6 IEC Power Connector | 12 Fuse Tray |

Figure 2-1. ESU 120e Rear Panel

ESU 120E INTERFACES

The ESU 120e is equipped with an Nx56/64 data port, a G.703 drop interface, an option slot, management interfaces, and an E1 interface in the rear panel. See Figure 2-2.

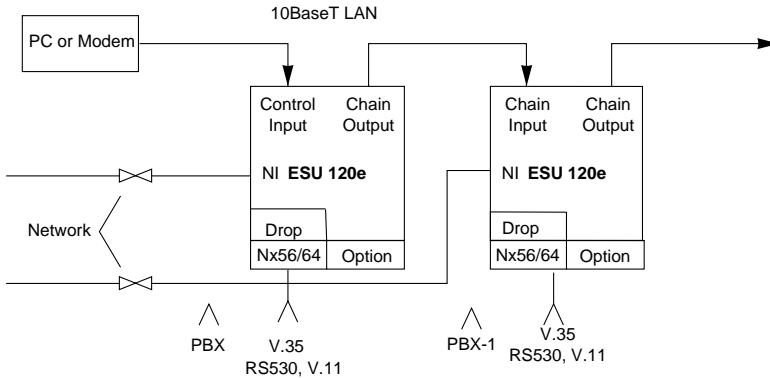

Figure 2-2. ESU 120e Interfaces

Network Interfaces

The Network Interface (NI) port provides the connection to the E1. This port complies with the applicable ANSI and CCITT standards. Either the 120Ω DB15 or the 75Ω BNC interface may be used for the Network Interface. The 75/120 selection must be made with the front panel menus. For more information see Wiring on page B-1.

Network Test Interface

The MON test jack provides a bridged access jack for non-intrusive monitoring of the incoming E1.

Nx56/64 Serial Interface

The Nx56/64 provides a serial interface that operates from 56kbps to 1.984Mbps. The Nx56/64 can be configured as a V.35, V.36, EIA-530, or V.11 electrical interface through the front panel menus. This port provides 511 pattern generation and detection, as well as remote loopback capability.

Drop (PBX) Interface

The drop interface provides a G.703 interface for a PBX or other equipment.

Control Port Input

The control port input provides an EIA-232 input from a PC or a modem for control of the ESU 120e. You can also use it as a chain input from another ESU 120e or ESU 100. For more information see Wiring on page B-1.

Chain Port Output

The chain port output provides an EIA-232 output to chain control to other ESU 120es. For more information see Wiring on page B-1.

10BaseT Interface

The 10BaseT interface provides the LAN interface for managing the ESU 120e with SNMP or T-Watch Pro. For more information see Wiring on page B-1.

POWER-UP TESTING

When shipped from the factory, the ESU 120e is set to factory default conditions. At the first application of power, the unit automatically executes a memory self-test. A full self-test can be run from the front panel, and a pass code and unit ID may be set using the UTIL menu.

Self-Test

Upon a power-up, the LCD displays **Memory Test Now Testing** and the Test LEDs are illuminated. When the self-test is completed with no failures detected, the OK LED lights up and the LCD momentarily displays **All Tests Passed**. If a failure is detected, a list of failures is displayed in the LCD window. The full self-test procedure (invoked from the front panel or T-Watch PRO) consists of the following tests:

Board-level tests

Each of the ESU 120e boards contains an on-board processor which executes a series of tests checking the circuitry on the board.

- RAM and EPROM tests.
- Verify on-board circuitry.

Unit-level tests

- Front panel LED verification.
- Board-to-board interface test. A test pattern is sent from the controller through a loopback on all other boards and checked on the controller. This verifies the data path, clocks, and control signals for the entire chassis.

Initialization

Set User Passcode

The ESU 120e is designed to operate with or without the use of a passcode. The default condition is without a passcode.



If the unit is to be remotely accessed using T-Watch PRO you must enter a passcode. When managing a number of units, the passcode can be the same for all the units.

The passcode should be a number easily remembered. Once entered, the passcode is required to access any operation other than viewing. See Set Passcode on page 6-2 for details.

Set Unit Identification

The Unit ID sets the unit to respond to remote control (controlled by a device other than the front panel or terminal). If no Unit ID is recorded it is not possible to operate from any remote control device, including the local PC for T-Watch PRO or SNMP. See Unit ID on page 6-4 for details.

Set Control Port

The ESU 120e can be configured from the control port when T-Watch PRO, SNMP, or the terminal interface are being used.

If the control port is to be used, the control port baud rate must also be selected.

Chain In (PC)

The unit can be controlled from an external PC connected directly or via modem to the chain-in port. when using chain-in, the selection of the control port baud rate from 9600 (factory default), 1200, 2400, or 4800, or 38400 must be made using the Unit Configuration menu. See Unit Menu on page 5-11 for details.

Unless locked out externally, the front panel can also control the unit.

Chain In/Chain Out

ESU 120e units and other ESUs can be linked together to form a chain. Figure 2-4 shows an example of a chain-in arrangement with a PC or a modem. The first ESU 120e in the chain receives controlling input from the PC or modem.

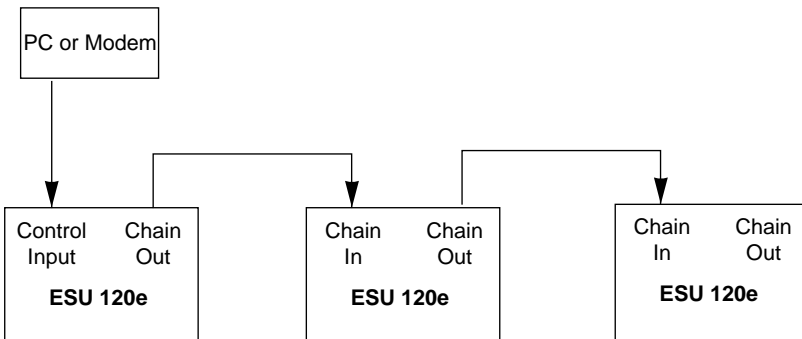

Figure 2-3. Example of Chain In

Subsequent ESUs in the chain are in a position to intake information from another ESU. This in-taking of information from another ESU in the chain is identified as *chain in*. The baud rate for the chained units must match that of the first unit.

Unless locked out externally, the front panel can also control the unit.

At this point, the Unit Initialization procedure is concluded. If the unit is to be configured remotely, there are no additional items necessary to complete prior to executing remote configuration.

The Passcode, the Unit ID, and the Control Port settings are stored in a nonvolatile memory. This assures they are operable for subsequent power-up sequences.

NORMAL POWER-UP PROCEDURE

After the unit has been put into operation with the initial power-up and initialization, subsequent power-up procedure includes only the Power-Up self-test followed by the request for a passcode (password) if this option was selected during initialization.

Use the number keys to enter the previously recorded passcode followed by pressing **Enter**.

FRONT PANEL

The ESU 120e front panel monitors operation and controls the configuration of the unit. The ESU 120e front panel is shown in Figure 3-1. Descriptions of each part of the front panel follow.

Name	Description
LCD Window	Displays menu items and messages in two lines by 16 characters. It also displays alarm and status information.
Enter Key	Selects active menu items. To select a menu item, press the number of the item. The menu item flashes, indicating it is activated. Press Enter to select the menu item.
Up and Down Arrows	Up and Down Arrows scroll through and activate the submenu items available in the current menu. When the submenu items are scrolled, the flashing cursor indicates the active parameters.
Cancel Key	Pressing the Cancel key stops the current activity and returns to the previous menu. Repeat until the desired menu level is reached. When a submenu item is displayed, press Cancel to exit the current display and return to the previous menu.
Numeric Keypad	The numeric keypad contains the numbers 0 through 9 which are used to activate menu items and enter information (such as the IP address).
Shift(entering special function keys)	Enter special function keys by pressing and holding Shift before pressing the key representing the desired character. See Operation Keys on page 3-4 for a description of the function keys. To activate a special function key rather than a number, press Shift and then the button. If a key is pressed without using Shift , the numbered item becomes active instead of the special function key.

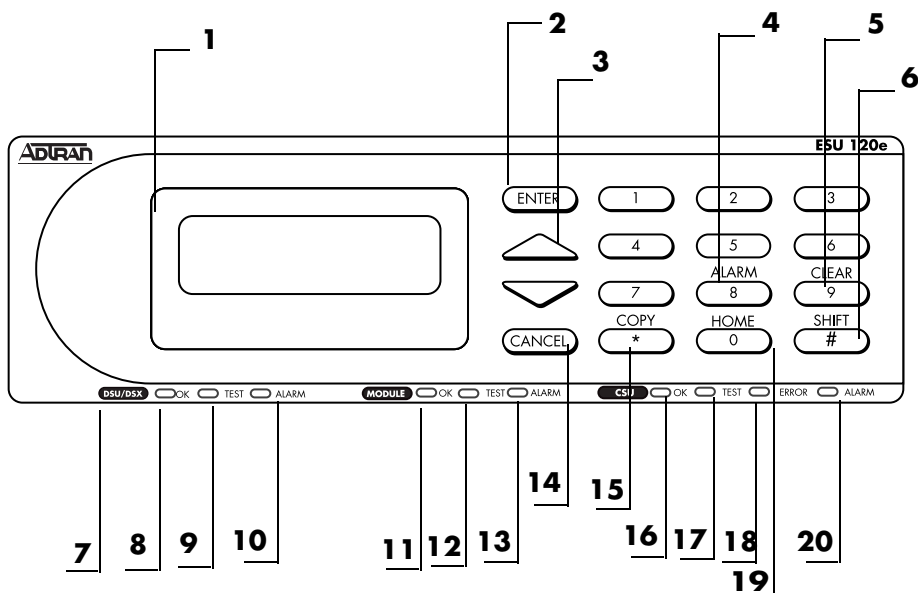

Figure 3-1. ESU 120e Front Panel Layout

No	Name	Description
1	LCD Window	Displays menu items and messages
2	Enter	Selects active menu item
3	Up and Down Arrows	Scrolls through/ activates submenu items
4	Alarm	Quick access to the active alarm display menu
5	Clear	Clears data/results fields
6	Shift	Provides access to special function keys
7	DSU/Drop	
8	OK (DSU/Drop status)	Data and Drop parts is in normal mode with no errors
9	Test (DSU/Drop Status)	Active when Data or Drop Port is in test mode
10	Alarm (DSU/Drop Status)	Active when alarm condition has been detected on Data or Drop Port
11	OK (Module Status)	Operation is in normal mode with no detected errors
12	Test (Module Status)	Active when the module is in test mode
13	Alarm (Module Status)	Active when an alarm condition has been detected
14	Cancel	Stops current activity and returns to the previous menu
15	Copy	Copies last data entered into the current TS0
16	OK (CSU Status)	Operation is in normal mode with no detected errors
17	Test (CSU Status)	Active when network interface is in test mode
18	Error (CSU Status)	Indicates errors such as BPV, OOF, and CRC
19	Home	Returns to main menu
20	Alarm (CSU Status)	Active when alarm condition detected on the network interface

LED Descriptions

CSU Status

The CSU status LEDs display the operational condition of the network interface located on the controller board in the unit.

Name	Description
OK (green)	Indicates the operation is in the normal mode and no errors have been detected.
Test (yellow)	Indicates that the network interface is operating in a test mode. This includes a self-test or a test loopback. When lighted, this LED also indicates that normal data flow is not occurring on the network interface.
Error (red)	Indicates an error such as a BPV, OOF, or CRC.
Alarm (red)	Indicates an alarm condition has been detected. When the alarm condition is no longer valid, the OK LED activates (turns on). To view an alarm condition, select the active alarm menu item or select Alarm by pressing Shift 8 . If the alarm conditions have been corrected, the alarm which caused the activation of the Alarm LED can be viewed under the Unit History menu.

DSU/Drop Status

Name	Description
OK (green)	Indicates the operation is in the normal mode and no errors have been detected.
Test (yellow)	Indicates that the interface is operating in a test mode. This includes a self-test or a test loopback. When lighted, this LED also indicates that normal data flow is not occurring in at least one of the module ports.
Alarm (red)	Indicates an alarm condition has been detected. When the alarm condition is no longer valid, the OK LED activates (turns on). To view an alarm condition, select the active alarm menu item or select Alarm by pressing Shift 8 . If the alarm conditions have been corrected, the alarm which caused the activation of the Alarm LED can be viewed under the Unit History menu.

Module Status

Name	Description
OK (green)	Indicates the operation is in the normal mode and no errors have been detected.
Test (yellow)	Indicates that one of the interfaces is operating in a test mode. This includes a self-test or a test loopback. When lighted, this LED also indicates that normal data flow is not occurring in at least one of the module ports.
Alarm (red)	Indicates an alarm condition has been detected. When the alarm condition is no longer valid, the OK LED activates (turns on). To view an alarm condition, select the active alarm menu item or select Alarm by pressing Shift 8 . If the alarm conditions have been corrected, the alarm which caused the activation of the Alarm LED can be viewed under the Unit History menu.

Operation keys

Name	Description
Copy	Used in the TS0 mapping menu operations to copy the last data entered into the current TS0. This key operates without pressing the Shift key.
Home	Returns home to the Main menu from any menu location.
Alarm	Used as quick access to the active alarm display menus. This can be activated while any other menu item is in use. When the Alarm menu is exited, the unit returns to the location of the same menu that was active when Alarm was selected.
Clear	Used in various menus to clear data/result fields.

General Menu Operation

The ESU 120e uses a multilevel menu structure containing both menu items and data fields. All menu operations and data are displayed in the LCD window. The menu items are numbered and can be viewed by scrolling with the **Up** and **Down** arrows.

Name	Description
Data Field	You can edit menu items followed by a colon (:).
Display Only Field	You cannot edit menu fields followed by an equal symbol (=). This symbol identifies a field used for value display only.
Arrows	Menus that display small Up or Down Arrows in the lower right corner indicate there are more menu items than are visible on a two-line LCD. Access the additional items with the up or down arrows. You can also access undisplayed menu items by using the appropriate menu number.

Select and Activate a Menu Item

To choose menu items, place the cursor on the desired menu item by pressing the number corresponding to the menu item or highlighting the menu item with the Up and Down Arrow. The following procedure describes how to activate the Alarm List option from the Status Menu.

Step	Action	Result
1	Activate the STATUS menu using the arrow keys or by pressing 1.	The cursor will flash on the number next to the activated selection.
2	Press Enter.	Use the arrow keys to view submenu items.
3	Choose an item on the submenu such as ACTIVE ALARMS.	
4	Select the submenu with the arrow keys or by pressing 3.	
5	Press Enter.	View the Alarm List using the arrow keys.

The menu tree below shows front panel menu travel.

1)STATUS	1) NI PERF RPTS	
	2) NI ERRORS	
	3) ACTIVE ALARMS	(ALARM LIST)
	4)VIEW HISTORY	END OF LIST
	5) PORT STATUS	
	6) REMOTE PORT	
	7) CLEAR PORT ALM	
	8) ENET STATUS	

Figure 3-2. Example of Basic Front Panel Menu Travel

Set the Data Field

You can edit data fields preceded by a colon (:).

Step	Action	Result
1	With the cursor positioned on the submenu item number, press Enter .	The cursor moves to the data field, (to the right of the submenu item name).
2	Using the arrows, scroll to scan the available value settings.	The value settings display one-at-a-time in the data field position.
3	When the desired value is displayed in the data field position, press Enter to set that value.	When the value is set, the cursor moves back to the submenu item position indicating the operation is complete.
4	Select another submenu field or press Cancel to return to the submenu.	Pressing Cancel prior to pressing Enter voids any data changes. The original data value is restored and the cursor returns to the submenu field.

Exit Any Menu Field Operation Or Display

Press **Cancel** as many times as required to return to the desired menu level or press **Home** to return to the main menu.

Data Port Identification

When configuring the unit, menu selections will include options from data port submenus. Selecting of data ports is necessary because the ESU 120e uses a Slot-Port method to identify which data port the menu item is referencing. If a module containing a PBX drop option card with an Nx56/64 plug-on interface is installed in the option slot, it would be designated as:

drop Passthru=1.1

Where slot=1 and port =1.

The drop is located in the option slot and is the first port in that slot.

Nx56/64=1.2

Where slot=1 and port=2.

The Nx is located in the slot and is the second port in that slot.

The ports that are built into the ESU 120e are referenced as Slot 0. The Nx56/64 would be designated as 0.1 and the drop would be referenced as 0.2.

Front Panel Menu Structure

The ESU 120e uses a multilevel menu structure containing both menu items and data fields. All menu operations and data display in the LCD window.

The opening menu is the access point to all other operations. Each Main menu item has several functions and submenus to identify and access specific parameters.

The front panel LCD of the Main menu contains four options: **Status, Config, Util** and **test**.

Name	Description
Status	The Status Menu displays all relevant information for the network and DTE interfaces. For detailed information on status options, see Status Menu in Chapter 4.
Config (Configuration)	The Configuration Menu displays and sets the ESU 120e operational configuration, including all network interface parameters, the allocation of the TS0s, and the port parameters. For detailed information on configuration options, see Configuration Menu in Chapter 5.
Util (Utilities)	The Utility Menu displays and sets system parameters. For detailed information on utility options, see Utility Menu in Chapter 6.
Test	The Test Menu initiates different types of unit tests and displays test results in the LCD window. For detailed information on test options, see Test Menu in Chapter 7.

Alternate Methods of Control

T-Watch PRO (ADTRAN PC Program)

T-Watch PRO is the ADTRAN PC control program. It provides complete control over the configuration of the ESU 120e using a graphical interface. The T-Watch PRO program displays the same status and performance data as the front panel LCD. This data is displayed in the form of tables and graphs.

The T-Watch PRO program has the following capabilities:

- Interfaces with a modem which permits dialing into a remote ESU 120e location to configure the unit or read the status or performance of the unit.
- Receives traps from any ESU product.
- Records and creates display performance data over a 30-day period.
- Accesses units via the local area network.

To set up the ESU 120e to work with T-Watch PRO over the LAN, follow these steps:

Step	Action
1	Set the Unit ID using the Front Panel. See Unit ID on page page 6-4 for details.
2	Set TCP/IP interface to 10BaseT (or SLIP) using the Front Panel.
3	Configure the IP address, default gateway, and subnet mask using the Front Panel.
4	Follow the installation instructions for T-Watch PRO to start the program and connect to the unit.

To set up the ESU 120e to work with T-Watch PRO over a direct EIA-232 connection, the following steps are required:

Step	Action
1	Set the Unit ID and set a passcode using the Front Panel. See Unit ID on page 6-4 and Set Passcode on page 6-2 for details.
2	Set the control port rate to the same setting as the PC Com port.
3	Connect the PC Com port to the Chain-In port on the ESU 120e using the DB25 adapter and modular cable provided.
4	Follow the installation instructions for T-Watch PRO to start the program and connect to the unit.

SNMP

The ADTRAN ESU 120e supports the Simple Network Management PROtocol (SNMP) through the 10BaseT or chain in (SLIP) interface. See Appendix A, for information on SNMP.

To use SNMP with the ESU 120e, do the following:

Step	Action
1	Set TCP/IP access as either 10BaseT or SLIP (Chain In Port).
2	Set the IP address, default gateway, and subnet mask through the front panel.
3	The appropriate MIB browser must be loaded into the Network Management Station (available on the ADTRAN webpage at http://www.adtran.com). The MIB browser issues SNMP gets/sets to the ESU 120e

Terminal Mode

The ESU 120e provides the front panel menus to a VT-100 type terminal. This mode can be used to configure and monitor the unit. Initiate this mode by typing <CTRL> PTT on the terminal once it is connected to the Control In port. For detailed information on this method of control, see Chapter 8, Telnet/Terminal Menus.

Telnet

You can connect to the ESU 120e via Telnet. Before attempting to connect via Telnet, first define the IP address, the default gateway, and the subnet mask using the front panel. When you begin the Telnet session, you will be prompted for a password. The default password is ADTRAN. You can change this password using the Management submenu. The Telnet session will time out after a pre-defined value that is also set in the Management menu.



NOTE *Only one Telnet session can be active at one time.*

The Status menu branch provides the ability to view the status of the ESU 120e operation. See Figure 4-1.

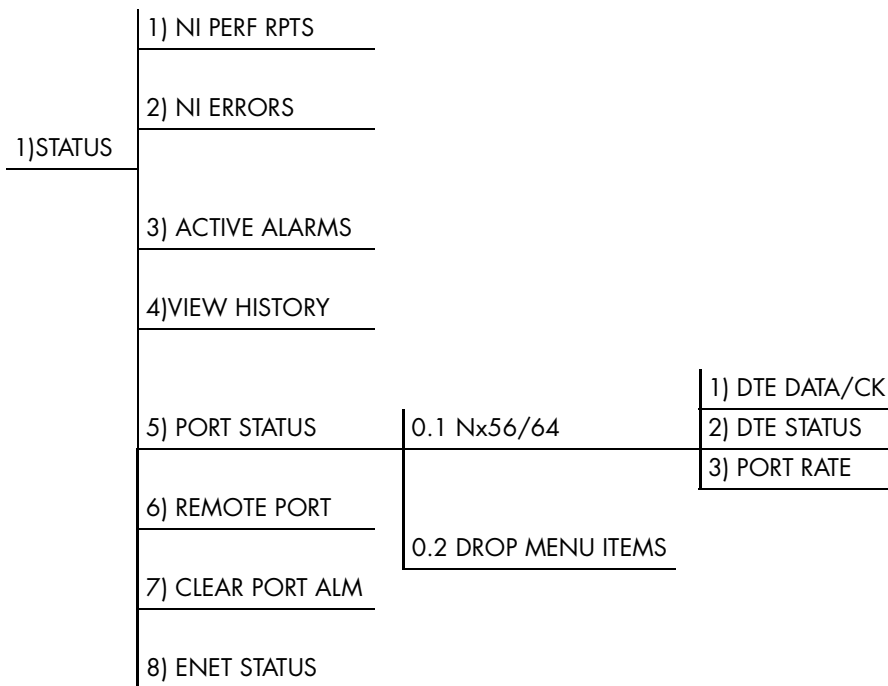

Figure 4-1. Status Menu Tree

Menu flow is normally depicted from left to right. Arrows on the lower right of the screen indicate the direction of scrolling to use to view additional menu items. At every level of the menu, pressing **Cancel** returns the system to the previous menu level. Pressing **Cancel** repeatedly returns the system to the Main Menu.

Network Interface Performance Reports (NI PERF RPTS)

The Network Interface Performance Reports display the user's copy of the performance data. The ESU 120e maintains this performance data on the network based on G.821. The data displayed is data accumulated over the last 15 minutes and over the last 24 hours.

Use the scroll keys to access the complete display of the following report fields:

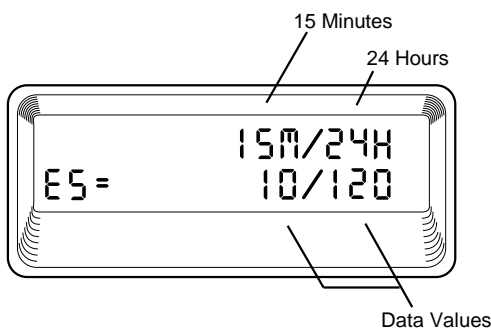

%AS	Percentage of available seconds
BES	Between 2 and 832 errors/sec
%EF	Percentage of error free seconds
DM	Number of minutes with bit error rate of 1×10^{-6} or greater
ES	Number of errored seconds (1 or more errors/second)
SES	Number of severely errored seconds (more than 832 CRC errors/sec). Approximate equivalent to a bit error rate of 1×10^{-3}
UAS	Number of unavailable seconds (10 or more consecutive seconds)

Figure 4-2. Network Interface Performance Report

If insufficient time has passed to collect data, NA displays. Continue with standard operating procedures to exit the display.

When this menu is active, performance data can be cleared by pressing **Clear (Shift 9)** on the keypad. Only the user's copy of the performance data is cleared.

Since only the user's copy of performance data is cleared by the ESU 120e, the data displayed here might be different from the data sent to the network as PRM data.

Network Interface Errors (NI ERRORS)

The NI Errors submenu displays the types of errors the Network Interface (NI) detects. A blinking CSU error LED indicates that network errors are detected.

The asterisk (*) above an item indicates the type of errors detected. The error types are the following:

- CRC** CRC-4 bit errors. This is valid only if CRC-4 mode is enabled.
- BPV** Bipolar violations.
- XS0** Excess zeros.
- FER** Framing errors.

Active Alarms

This menu item displays a list of current alarms reported by either the base controller or any of the ports. If no alarms are current, using this menu item displays End of List.

This display includes two lines of text. The top line is the alarm source. The bottom line is the alarm message. A list of alarm messages is found in the appendix, ESU 120e System Messages.

In addition to normal menu operation, you can also access this menu item with the **Alarm function (Shift 8)** on the keypad. If one or more of the Alarm LEDs are illuminated, an alarm is present. Pressing **Cancel** returns to the previous menu item.

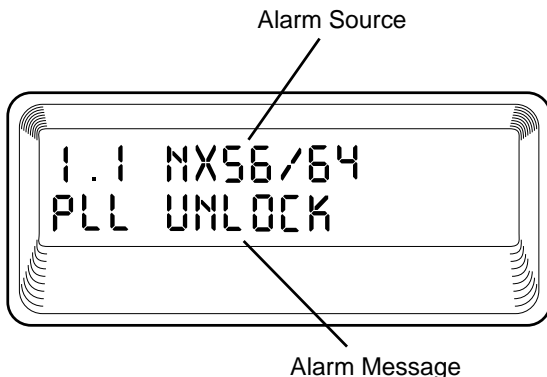

Figure 4-3. Display of Alarm Messages

View History

This menu item both displays and clears the accumulated status changes of the unit.

View History displays a history of the first 20 status changes in the unit, including the date, time, and type of change. The unit also records for viewing, the date and time an alarm became active or inactive, as well as the date and time of test activation or deactivation.

To clear the View History display, press **Clear (Shift 9)** with the View History menu active.

Port Status

Port Status displays the signals monitored on the data ports. For example, the Nx56/64 interface monitors the RTS, CTS, RD, and RD, along with other signal lines. When a port is selected, the LCD indicates if the signal is present.

The base Nx interface offers the status screen listed in this section. When using other option cards, refer to the appropriate User's Manual for a definition of any status screens offered.

The Port Status of Nx56/64 is examined as an example of how to use this item.

0.1 Nx56/64 Menu Items

DTE Data/CK

An asterisk (*) indicates an active status of the following lines.

TXD	Transmit data from the DTE
RXD	Receive data toward the DTE
ETC	External Transmit Clock from DTE
LCK	Lock Status of the phase locked loop

DTE Status

An asterisk (*) indicates an active status of the following lines:

RTS	Request to send from DTE
CTS	Clear to send to DTE
DCD	Data carrier detect to DTE
DSR	Data set ready to DTE

Port Rate

The Port Rate displays the current setting of the Nx port. Continue with standard operating procedures to exit the display.

0.2 Drop Menu Items (DSX Errors)

- CRC** An asterisk displays under the CRC if there are CRC errors in extended superframe format (ESF) mode. If CRC-4 is not enabled on the Drop Port, the LCD displays n/a.
- BPV** An asterisk displays under the BPV if the Drop Port detects bipolar violations.
- SLIP** An asterisk displays under the SLIP if the drop plug-on board detects frame slips. This is caused by multiple clock sources in the application.
- FER** An asterisk displays under the FER if the Drop Port detects frame bit synchronization errors.

Remote Port

Remote Port displays the status of activity on the Control In remote port. This is useful for troubleshooting communication sessions, and for verifying cabling.

- RX** Characters received at remote port
- ID** Unit ID received at remote port
- CR** Correct CRC received
- C**
- PC** Correct passcode received
- TX** Characters transmitted from the remote port

Clear Port Alarm

Clears the Link Failed alarms on option modules that have been removed from the ESU 120e chassis.

ENET Status

- TX** Indicates that data is being transmitted from the 10BaseT port
- RX** Indicates that data is being received by the 10BaseT port.
- LN** Indicates the current status of the 10BaseT link integrity test
- K** (this should always be on when the unit is connected to a functional 10BaseT hub.
- CPU** Active when the CPE is accessing the 10BaseT interface.

The Configuration menu sets the ESU 120e operational configuration, including all network interface parameters, the allocation of the DS0s, and the port parameters. See Figure 5-1 on page 5-2.

Menu flow is normally depicted from left to right. Arrows on the lower right of the screen indicate the direction of scrolling to use to view additional menu items. At every level of the menu, pressing **Cancel** returns the system to the previous menu level. Pressing **Cancel** repeatedly returns the system to the Main menu.

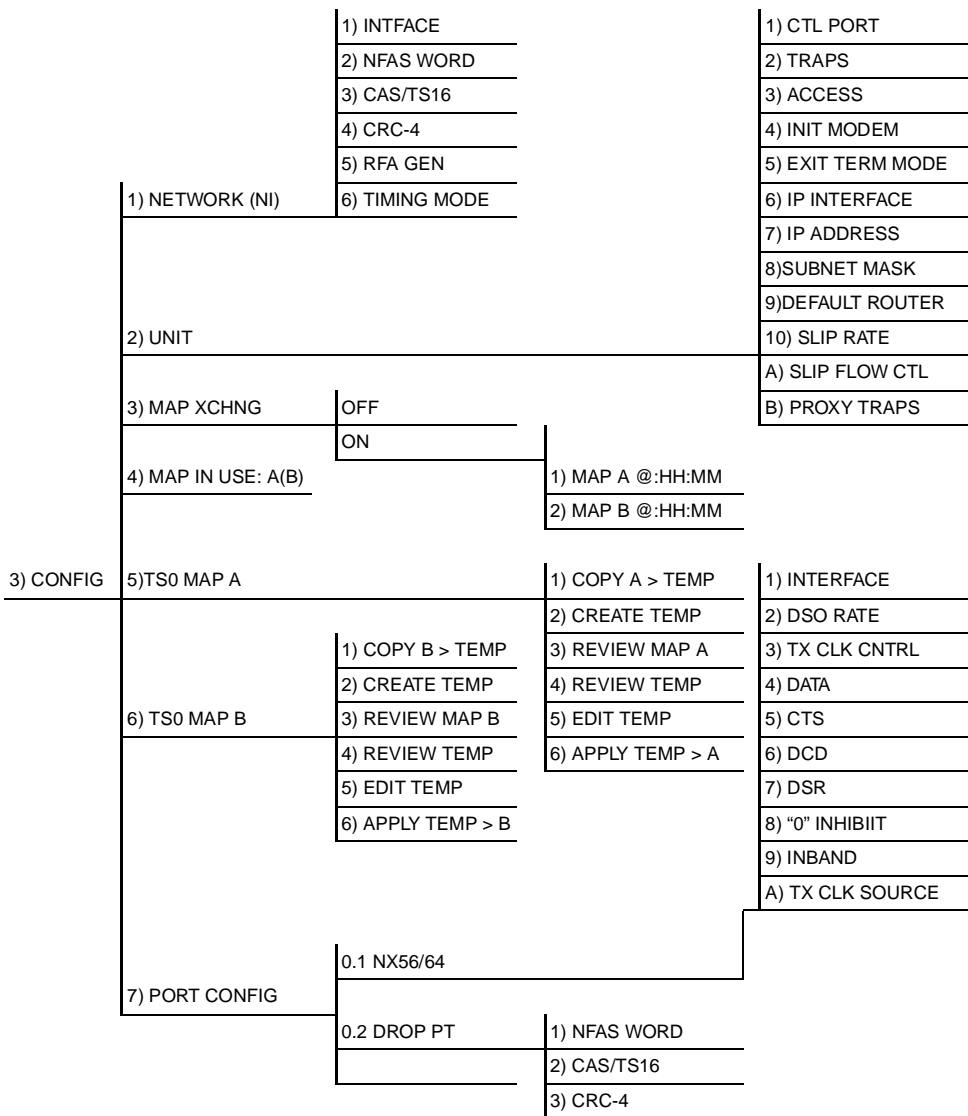



Figure 5-1. Configuration Menu Tree

NETWORK (NI)

This menu item accesses the configuration of parameters associated with the network interface in the base unit. There are eight sub-menu items that include setting the format, the line build out (LBO), and the timing mode.

Network (NI) Menu Items

The menu items are:

Menu Item	Description
Interface (INTFACE)	<p>Selects either the 120Ω DB15 interface or the 75Ω BNC interface. Choices: 120Ω, 75Ω BAL and 75Ω UNBAL</p> <p> NOTE In 75Ω UNBAL mode, both the Tx and Rx are shield grounded.</p>
Framing	<p>NFAS Word. If enabled, the network interface receiver requires the NFAS word (TS0 in odd frames) and the FAS word (TS0 in even frames) for frame sync. When disabled, only the FAS word is needed for frame sync. Choices: Enable, Disable</p>
CAS/TS16	<p>Enables/Disables Channel Associated signalling (time slot 16 multiframing). When this menu option is enabled, the following occurs:</p> <ol style="list-style-type: none"> 1. The TS16 multiframe alignment signal is inserted in the outgoing data stream. 2. Signaling Bits are transmitted in TS 16 for all TS0s that are mapped to a signalling-capable port (Base Drop port, for example). In TS0s that are mapped to "Idle" or data ports, "1s" are transmitted in the signalling bit positions. 3. The TS16 multiframe alignment signal must be received for frame sync.

Menu Item	Description
	<ul style="list-style-type: none"> • Note that if CAS/TS16 is enabled, TS16 may not be mapped to a port, and will be forced to "Idle". When CAS/TS16 is disabled, and TS16 is mapped to a port, the data in TS 16 will be mapped through from the network to the mapped port. For common channel signalling applications, CAS/TS16 should be disabled and TS16 mapped to the drop port. TS16 may also be mapped to the base Nx56/64 or an option module data port. • When CAS/TS16 is enabled, TS16 is forced to idle in DS0 Map A and B and may not be mapped. This configuration must be used if there are multiple signalling-capable ports that are mapped to the Network Interface. For applications where the Base Drop Port requires channel associated signalling, (connection to a PBX, for example) CAS/TS16 must be enabled and TS16 left idle in the DS0 Map.
CRC-4	<p>When this option is enabled, the CRC-4 checksum bits are transmitted in the outgoing E1 data stream. Also, the received signal is checked for errors.</p> <p>Choices: Enable, Disable</p>
RFA Gen	<p>When enabled, remote frame alarm is transmitted toward the Network during alarms.</p> <p>Choices: Enable, Disable</p>
Timing Mode	<p>Selects the clock source for transmission toward the network from the NI. See <i>ESU 120 Clock Sources on page 5-5</i> for more information.</p>

ESU 120e CLOCK SOURCES

The ESU 120e is operable from various clock sources permitting it to perform properly in many different applications. Set the network interface clocking options with the clocking options set by the Network (NI) Configuration menu options.

The following clock source options are available:

- Network Timed
- Base Drop Timed
- Base DTE Timed
- Internal Timing
- Normal (CSU) (only when secondary interface module is installed)

**NOTE**

The selected clock option always designates the clock source for transmission. Clocking necessary for receiving data is always recovered from incoming data.

Network Timed

The network is the source of timing. The received data clocking is looped back to the network where it is used to determine the transmission timing. This option is also referred to as loop timed as the transmission clock is derived from the received clock. See Figure 5-2.

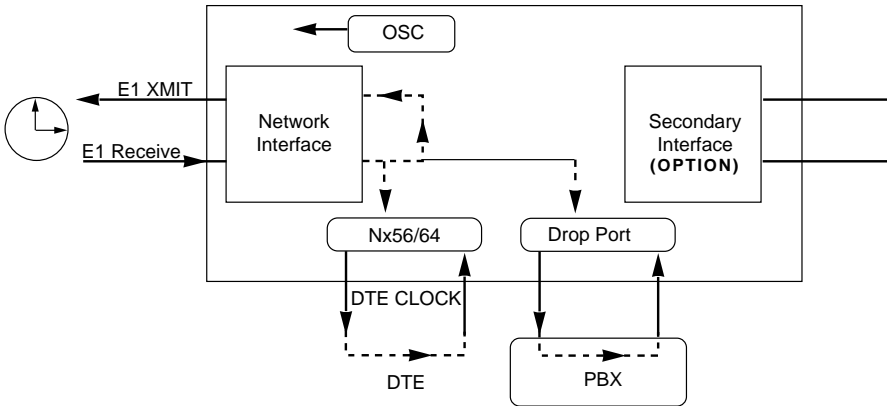

Figure 5-2. Network Timed Clock Source

Base Drop Timed

The PBX is the source of timing. The ESU 120e uses the clock derived by the Base Drop interface for transmission timing (see Figure 5-3).

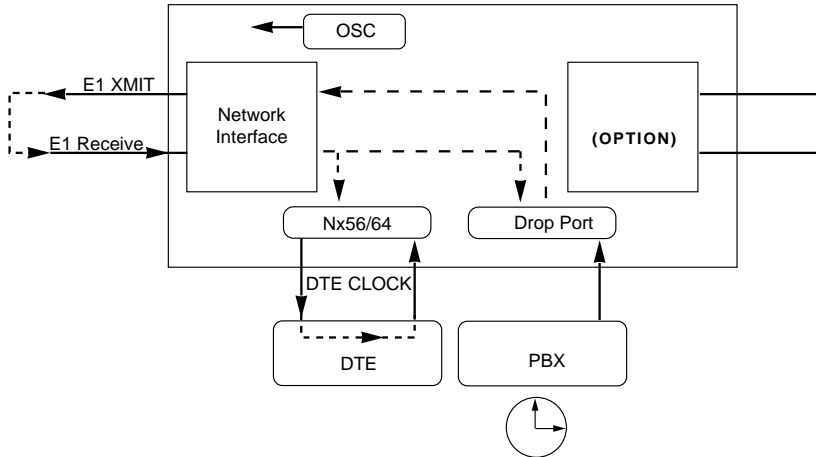

Figure 5-3. Drop Timed Clock Source

Base DTE Timed

The DTE is the source of timing. The ESU 120e uses the incoming DTE clock to determine the transmission timing. This is typically used in applications where it is necessary to have the DTE as the primary clock source, (such as limited distance line drivers). See *Figure 5-4*.

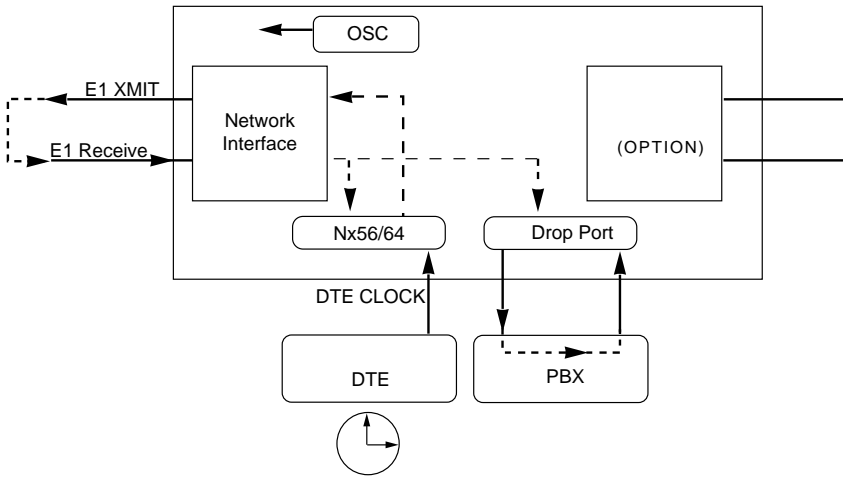

Figure 5-4. Network Timed Clock Source

Internal Timing

The ESU 120e is the source of timing. The ESU 120e is configured to use its own internal oscillator as the source of timing. Applications include private line driver circuits where one end is set to network and the other to internal. See *Figure 5-5*.

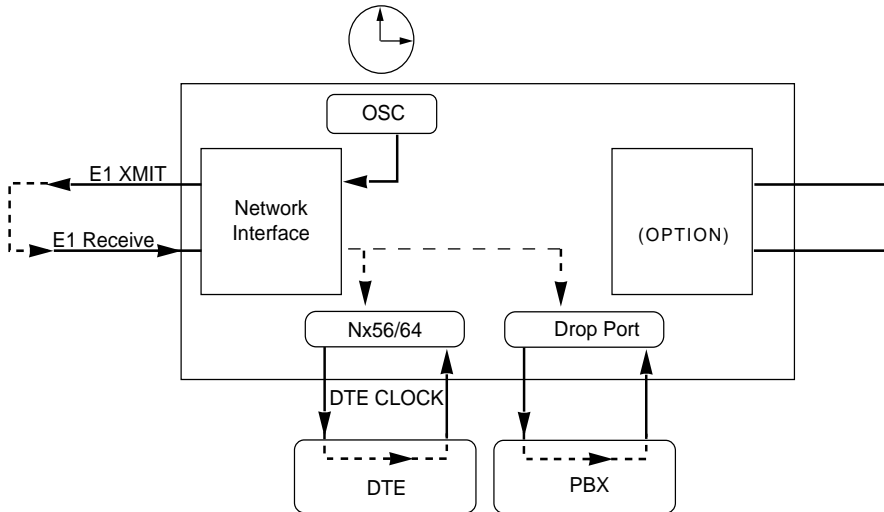

Figure 5-5. Internal Clock Source

Normal (CSU) Timing

The typical timing option arrangement is shown in Figure 5-6. The PBX is looped timed sending data to the ESU 120e which is actually synchronous to the received data. The Network Interface (NI) is the actual source of all timings. This timing option is the same as that typically used for CSUs. This is the preferred mode for use with a PBX application.

This timing mode works equally well when the PBX is the source of timing. In that configuration the network would not be providing timing.

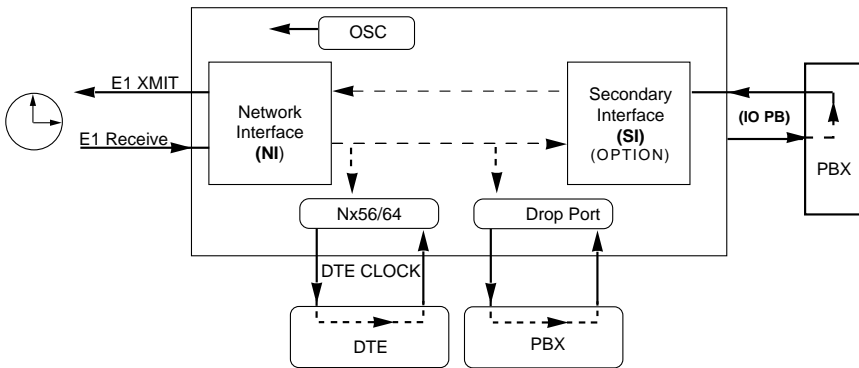



Figure 5-6. Normal (CSU)



The network interface and secondary interface clocking options are set by using the Network (NI) Configuration menu options.

Unit Menu

The Unit menu changes the baud rate of the Control In port and the setup of the Dial Out port. The menu items are:

Menu Item	Description
Ctl Port	Sets the baud rate for communication with the PC or modem. Choices: 1200, 2400, 9200, 9600, and 38400 kbps
Traps	Enables or disables the transmission of trap messages. Choices: Enable and Disable
Access	Sets the method of connection from the ESU 120e to T-Watch/SNMP. Choices: Direct - Used if connected directly to the PC. Dial - Used when connection is through a modem. The dial string is entered from T-Watch/SNMP.
Init Modem	Allows you to choose an industry standard or a custom initialization string for a modem connected to the control port. Choices: Industry standard and Custom Initialization String
Exit Term Mode	Takes the unit out of terminal mode.
IP Interface	Selects the TCP/IP physical interface; 10-Base-T Ethernet or SLIP using the EIA-232 serial port. Choices: 10-Base-T Ethernet or SLIP  NOTE <i>If this option is set to SLIP, the EIA-232 port may not be used as a terminal interface.</i>
IP Address	This is the IP address that uniquely identifies the ESU 120e on a TCP/IP network. This address is composed of four decimal numbers, each in the range of 0 to 255, separated by periods. This value is used for either the 10BaseT Ethernet or SLIP interface, depending on the IP interface setting

Menu Item	Description
Subnet Mask	This defines which part of a destination IP address is the Network number. It is used along with the ESU 120e IP address to determine which nodes must be reached through the default IP Gateway. This value is set to 0.0.0.0 when the IP interface option is set to SLIP.
Default Router	All IP Packets destined for nodes not on the ESU 120e unit's local network are not forwarded through this IP address. Normally, this address defines a router connected to the ESU 120e unit's local network. This value is ignored when the IP interface is set to SLIP.
SLIP Rate	This sets the baud rate for the Chain-In port when used as the SLIP connection for SNMP management. Choices: 1200, 2400, 9600, 19200, 38400
SLIP Flow CTL	This is used to activate flow control on the Chain-In port when used as the SLIP interface. Hardware mode uses RTS and CTS. Choices: None, Hardware
Proxy Traps	This determines which interface is used for forwarding traps from units being "proxied" for. Choices: 10 BaseT, Chain-In

Map Exchange (Map Xchg)

The Map Exchange menu enables and sets the automatic time of day map switch. The unit provides selection of the hour, minute, and seconds for the map switching to take place. The menu items are:

Menu Item	Description
OFF	Indicates the map in use does not change (disabled).
ON	<p>Indicates that the map in use will change at a user-selected time of day (enabled).</p> <p>Scroll to select Auto to enable or Off to disable the Automatic Map Change feature and press Enter to activate the selection.</p> <p>When Auto is selected, the unit displays the screens to set times for switching. After editing Map A, press Enter to record the Map A settings and activate the selection fields for Map B. Use the same operation to edit switching time for Map B.</p>

Map In Use: A(B)

This menu item controls the TS0 map the ESU 120e uses and displays the map in current use.

TS0 Map A and TS0 Map B

The TS0 maps designate which TS0s are assigned to which port. There are three maps, TS0 Map A, TS0 Map B, and the Temporary (Temp) map. See Figure 5-7.

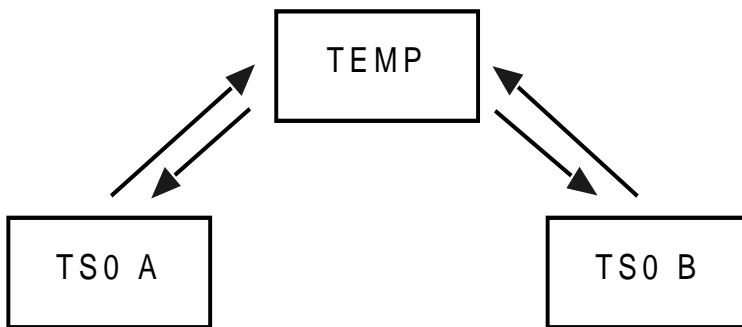



Figure 5-7. DS0 Map Designations

TS0 A and TS0 B are the current maps the ESU 120e uses. The Temp map generates a map before putting it into use.

You can copy TS0 A to TS0 B by copying the TS0 A map into the TEMP map. Then apply (write) the TEMP map into TS0 B.

The menu items are:

Menu Item	Description
COPY A >TEMP	This copies the current map (A or B) into a TEMP map area. This permits modification without disturbing the existing map. When the modifications are completed, the TEMP map is written to current MAP A (B) by selecting Apply.
CREATE TEMP	<p>This creates a map by defining a port or Idle for all TS0s. When CREATE TEMP is first selected, all TS0s are set to Idle.</p> <p>PORT: IDLE, TST, + option module ports</p> <p>TST designates which TS0s are used for QRSS testing when activated under the 4)TEST Menu. When not used for testing, the TST designation is identical to IDLE.</p> <p>With the cursor on CREATE TEMP, press Enter. The unit displays the selection screen with the cursor positioned on the first selection TS0 number. See Figure 5-8.</p> <div data-bbox="573 906 884 1128" style="text-align: center;"> </div> <p>Figure 5-8. Create Temp Selection Screen</p> <p>Use either the scroll method or numbers to enter the TS0 number (do not mix the use of the keys). Pressing Enter completes the selection and moves the cursor to PORT, the next field.</p>

Menu Item	Description
	<p>Scroll to select the port which is dependent on the installed option card. Press Enter to complete the selection and move the cursor back to the TS0 field. With the cursor on the TS0 field, the TS0 number can be incremented or decremented by scrolling. If Copy is pressed, the contents of the last TS0 entered are placed in the new TS0 number. When all entries are complete, Cancel moves the cursor to the last of the submenu choices, 6)APPLY. Either apply the newly created TS0 map or press Cancel to return to the TS0 Map A (B) submenu choices.</p> <p> NOTE <i>Selecting Apply will not disrupt the operation of unmodified ports</i></p>
REVIEW MAP A(B)	Permits a quick review of the number of TS0s assigned to each port and the number of unassigned TS0s (Idle or TST) as defined in the currently applied Map A(B).
REVIEW TEMP	This menu item is operated the same for the TEMP map as is 3)REVIEW MAP A or Map B.
EDIT TEMP	The map in the TEMP file can be edited to whatever configuration is desired. If Map A had been copied into the TEMP file, then after editing, the TEMP file could be applied to MAP A or MAP B. The menu operation is identical to 2) CREATE TEMP with the exception that the existing port selections display.
APPLY TEMP > A	Writes the TEMP map into Map A. Apply is usually the last step in updating a map and is accessed automatically at the end of editing or creating a temporary map. Currently, it can be bypassed by selecting another menu choice.

Port Configuration (Port Config)

Port Configuration selects and configures the parameters associated with any data port in the unit. For example, parameters for the Drop Port Interface (PBX) interface are set through this menu. The items that can be set depend on which option module is installed. The list of option ports will vary with the configuration.

The ESU 120e is designed so that any additional ports developed in the future will contain the appropriate menu selections to provide access by use of this menu item.

The Config menus for options ports are described in separate sections of the manual supplied with the option card.

0.1 Nx56/64 Port Configuration (Port Config) Menu Items

The menu items are:

Menu Item	Description
INTERFACE	This option sets the electrical interface for the Base Nx56/64 port. Choices: V.35, V.11 (X.21), RS530, V.36
TSO RATE	This sets the base rate of the interface. The actual data rate depends on the number of DS0s assigned to the Nx port. Choices: 56K or 64K
TX CLK CNTRL	Controls the clock used by the TSU 120e to accept transmit (TX) data from the DTE. The default is normal. If the interface cable is long, causing a phase shift in the data, the clock can be selected as Invert. This switches the phase of the clock which should compensate for a long cable. Choices: Normal, Invert

Menu Item	Description
DATA	<p>Used to control the inverting of the DTE data. This inversion can be useful when operating with an HDLC protocol. Often used as a means to ensure 1s density. Choices: Normal or Invert</p> <p> <i>If Invert is selected, zero (0) inhibit should also be selected to prevent an open DTE input from placing zeros on the network.</i></p>
CTS	<p>Used to control characteristics of CTS. Choices: Normal, (see Table 3-A) or Force On</p>
DCD	<p>Data Carrier Detect. Indicates to the DTE when a valid signal is being received at the Network Interface. Choices: Normal (see Table 3-A) or Force On</p>
DSR	<p>Data Set Ready. This signal indicates to the DTE when the DCE is turned on and ready for operations. Choices: Normal (see Table 3-A) or Force On</p>
0 INHIB	<p>The Nx interface will detect an uninterrupted string of zeros (0s) being transmitted toward the network. If 0s are transmitted for >1 second, the TSU 120 will force 1s. Choices: On or Off</p>
INBAND	<p>The Nx56/64 port is capable of providing an inband communications channel (for T-Watch and SNMP) between units. This is accomplished by using 8 kbps of the first DS0 assigned to that particular Nx56/64 port. If in 56 K mode, no data bandwidth will be used. Inband must also be enabled at the destination port. Choices: On or Off, On Demand</p>
TX CLK SOURCE	<p>This controls the source of the clock used by the TSU 120e to accept transmit data from the DTE. The default is Internal. If the application requires that the DTE device provides the clock with the transmit data, the External setting is used. Choices: Internal, External</p>

Table 5-1. Normal Mode of Operation

RTS	Signal	V.54 Loop-back	511 TST ON	Self Test Active	Netwk Test Active	No DS0 Mapped	Network Alarm
CTS	Follows	OFF	OFF	OFF	OFF	OFF	OFF
DCD	—	—	—	OFF	—	OFF	OFF
DSR	—	OFF	OFF	OFF	OFF	OFF	—

Where “—” = don't care
 *Until backup becomes active

0.2 Drop Port Configuration (Port Config) Menu Items

The menu items are:

Menu Item	Description
NFAS Word	NFAS Word. If enabled, the network interface receiver requires the NFAS word (TS0) in odd frames) and the FAS word (TS0 in even frames) for frame sync. When disabled, only the FAS word is needed for frame sync. Choices: Enable, Disable
CAS/TS16	Enables/Disables Channel Associated signalling time slot 16 multiframing). When this menu option is enabled, the following occurs: <ol style="list-style-type: none"> 1. The TS16 multiframe alignment signal is inserted in the outgoing data stream (toward the PBX). 2. Signaling Bits are transmitted in TS 16. 3. The TS16 multiframe alignment signal must be received for frame sync. <p>NOTE <i>If CAS/TS16 is enabled on the Drop Port, it must also be enabled on the Network Interface.</i></p>
CRC-4	When this option is enabled, the CRC-4 checksum bits are transmitted in the outgoing data stream toward PBX. Also, the received signal is checked for errors. Choices: Enable, Disable

The utility menu tree displays and sets system parameters (see Figure 6-1). This includes setting the time and date, resetting all parameters to factory values, or re-initiating the unit. This menu also displays the unit software revision and the unit ID setting.

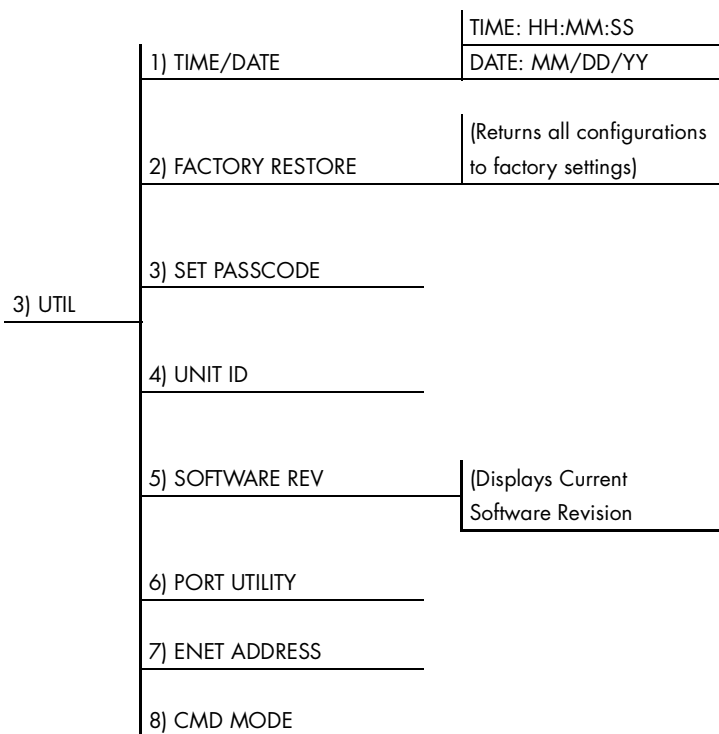

Figure 6-1. Utility Menu Tree

Menu flow is normally depicted from left to right. Arrows on the lower right of the screen indicate the scrolling direction to view additional menu items. At every level of the menu, press **Cancel** to return the system to the previous menu level. Pressing **Cancel** repeatedly returns the system to the Main menu.

Time/Date

This menu option displays or edits the current time and date. The ESU 120e maintains the time and date during power-off conditions.

Pressing **Enter** after any numeric change always records the entry and moves to the next editing position. You can also move to a different field to edit by pressing **Enter** at the editing position without making any change, or by using the **Up** and **Down Arrow** keys. Pressing **Cancel** at any time ends the editing process.

Factory Restore

This menu item restores the factory default settings for all unit parameters, including configured TS0 maps.

Set Passcode

Enter Passcode from Other Menus

The Passcode prompt may make an unexpected appearance from other menu operations. This happens only when the unit is operating in the limited access mode, i.e., without an active passcode. The limited access mode may become active even if a passcode was entered as it does when there is no activity for ten minutes. If the unit is to be remotely accessed using T-Watch PRO, a passcode must be entered. When managing a number of units, the passcode can be the same for all.

The unexpected appearance of the Passcode prompt occurs, for example, while operating in a limited access mode and attempting to change the Data Rate, (2)CONFIG, 2)UNIT, 1)CNTROL PORT, 1)DATA RATE. Use the number keys to enter the correct passcode and press **Enter**. The unit displays Access Granted.

Pressing any key after entering a passcode causes the unit to return to the previous active menu. In this case it returns to 2)CONFIG, 2)UNIT, 1)CNTRL PORT, 1)DATA RATE to permit changing the data rate.

Change/Set a Passcode

The passcode can be changed or set at any time or eliminated altogether through the Utility menu item 3)SET PASSCODE. This procedure requires the current passcode (if one is established) for operation.

The passcode can only be entered by using numbers. After entering the desired passcode, press **Enter**.

Set a null passcode at the 3)SET PASSCODE menu by pressing **Enter** without any numbers. This sets a null passcode and grants unlimited access.

Special Feature

For added security protection the unit is equipped with an automatic time-out for operation with the password. After ten minutes of inactivity, the unit reverts to limited access operation. To make changes in the configuration, the passcode can be reentered. If the passcode number is lost, contact ADTRAN Customer Service for assistance.

No Passcode Desired

At the New Passcode prompt (in the Set Passcode menu), press **Enter** without any numerical entry. The system nullifies the need to enter a password for subsequent use and proceeds to the Unit ID prompt.

Unit ID

This menu is used to access the current Unit ID setting. Viewing is available in limited access mode. Editing or changing the Unit ID requires the use of a password as in editing mode. Unit Identification numbers must be between 2 and 250. If an out-of-range number is entered, the unit assumes the upper limit number of 250.

To Set the Unit Identification

In the Unit ID menu (item 4) under the UTIL menu, enter any value between 2 and 250. The number 1 is reserved for the PC.

Pressing **Enter** records the Unit ID number and establishes its availability for operation by remote control. The unit proceeds to the Set Control Port prompt.

No Unit ID Desired

Without entering any numbers at the Unit ID prompt, press **Enter**. Pressing **Enter** with no Unit ID recorded establishes the unit as not able to be operated by remote control.

Software Revision (Software Rev)

This menu provides access to the display of the current software revision level loaded into the base unit controller. This information is required when requesting assistance from ADTRAN Customer Service or when updates are needed.

Use **Cancel** to exit.

Port Utility

This menu provides access to the display of the current software information for each port installed in the unit. This information is required when requesting assistance from ADTRAN customer service or when updates are needed.

Enet Address

Displays the Ethernet address for the 10BaseT port.

CMD Mode

Reserved for factory use.

The Test menu initiates different types of unit tests and displays test results in the LCD window. The Test menu contains four items. See Figure 7-1.

Executing tests will disrupt some of the normal operation. See individual menu items concerning tests before executing.

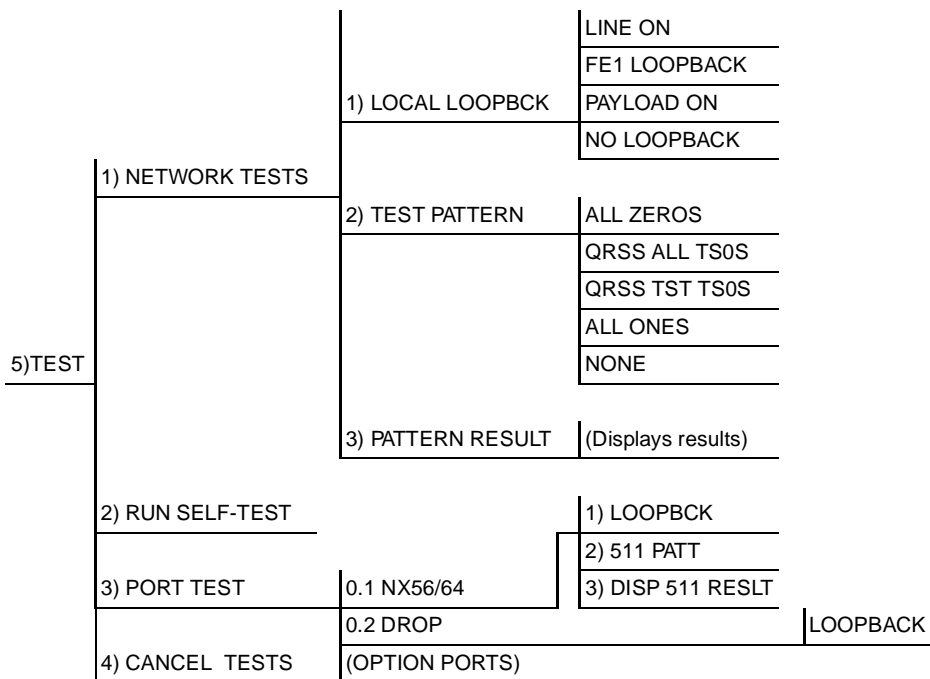

Figure 7-1. Test Menu Tree

Menu flow is normally depicted from left to right. Arrows on the lower right of the screen indicate the scrolling direction to view additional menu items. At each level of the menu, pressing **Cancel** returns the system to the previous menu level. Pressing **Cancel** repeatedly returns the system to the Main menu.

Network Tests

Network tests control the activation of loopbacks and the initiation of data test patterns.

Network tests are run on the Network Interface (NI). You can select three different test configurations to determine the type of loopback and the pattern to run. Test results display in the LCD window.

Executing Network Tests will disrupt normal data flow unless only TST TS0s are selected for testing.

Loopback Tests

A number of different loopbacks can be invoked locally from the front panel, by T-Watch commands, or remotely by using special in-band codes (AT&T D4 network loop-up and loop-down codes). Additionally, the loopbacks can be remotely controlled by means of out-of-band commands by the E1 ESF FDL or from T-Watch PRO via a modem connection.

Network Interface Loopbacks

Network interface loopbacks (see Figure 7-2 on page 7-3) affect the entire E1 data stream. There are two types of network loopbacks, line loopback and payload loopback.

Line loopback loops all of the received data back toward the network. The transmitted data is the identical line code that was received, including any bipolar violations or framing errors.

Payload loopback is similar to line loopback, except that the framing is extracted from the received data and then regenerated for the transmitted data.

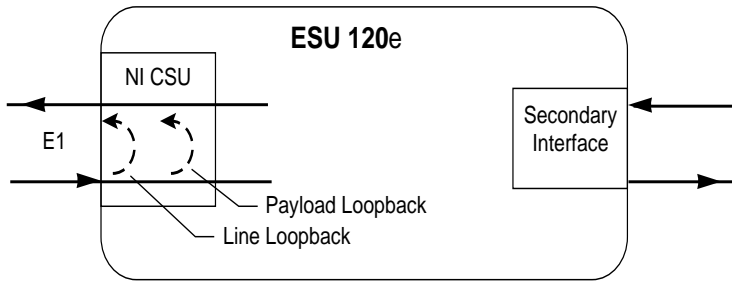

Figure 7-2. Network Loopback Tests

LOCAL LOOPBACK

There are three available choices for setting the local loopback:

- Line On** Activates the line loopback
- Payload On** Activates the payload loopback
- No Loopback** Deactivates the loopback

Scroll to select a setting and record it by pressing Enter. The unit returns the display of 1)LOCAL LOOPBCK and 2)REMOTE LOOPBCK

REMOTE LOOPBCK

FE1 Loopback sends V.54 loopback code in all mapped TSOs toward the network. Far end will respond by initiating a local line loopback.

TEST PATTERN

All Ones

Sends an all ones pattern to the network.

All Zeros

Sends an all zeros pattern to the network.

QRSS Pattern

The QRSS pattern is commonly used to simulate real data in E1 interfaces. This pattern can be assigned to appear in all TS0s or only in TST TS0s. When QRSS is set in all TS0s and one of the network loopbacks previously described is activated at the far end, a total end-to-end integrity check can be run without the need for any external test equipment. When QRSS is assigned to TST TS0s, an integrity check of the link can be run along with normal data flow. The TST TS0s are user assigned as part of the TS0 Map.

This sets the pattern for the test and initiates the transmission of the pattern. The test is terminated by selecting None. The following patterns are available:

QRSS All TS0s	Generates a QRSS test pattern and inserts the pattern into all TS0s
QRSS TST TS0s	Inserts a QRSS pattern in those TS0s mapped as TST in the currently active map (A or B)
None	Terminates pattern generation



NOTE QRSS always runs at 64K/TS0.

For example, use the up and down arrows to select QRSS ALL TS0s. Press **Enter** to record the selection. The ESU 120e starts to generate a QRSS test pattern and inserts the pattern into all TS0s. To end the test, select **None**.

PATTERN RESULT

Displays the results of the test currently active. Leaving and returning to this menu item does not interrupt the test.

Pressing **2** injects errors into the test pattern. These errors are detected by the device performing the pattern check.

ES The number of seconds with at least 1 bit error.

BES The number of seconds with more than 1 bit error and less than 320.

SES The number of seconds with more than 320 bit errors.

SYNC Indicates if pattern sync is (yes) or is not (no) valid. The asterisk () indicates if pattern sync has been lost since the start of testing.

Clear results by pressing shift 9. The results are accumulated until the test pattern is set to **None** or **Cleared**.

Using TST TS0s for testing can be very useful, particularly in Fractional E1 applications. You can run an end-to-end test on the Fractional TS0s by 1) setting for Map B the TST in the same TS0 as used by Map A to receive data from an Nx56/64 port and 2) by looping the far end using a V.54 loopback code on the Nx56/64 port. In addition, a single TS0 can be used for continuous testing while other TS0s are passing normal data. This will also provide an end to end check on the entire link. Set each end to send QRSS in TST TS0s (using 1 TS0) and occasionally view the results on the Pattern Result menu selection.

Run Self-Test

The self-test checks the integrity of the internal operation of the electronic components by performing memory tests and by sending and verifying data test patterns through all internal interfaces. Although actual user data cannot be passed during these tests, the self-test can be run with the network and DTE interfaces in place and will not disturb any external interface.

The memory portion of the self-test automatically executes upon power-up. A full self-test can be commanded from a front panel menu or from T-Watch PRO.

In addition to the specified self-tests, background tests are also run on various parts of the internal electronics. These run during normal operation to confirm continued correct functioning.

This menu selection is used to execute a full internal self-test. The results of the self-tests are displayed in the LCD. Upon invoking the command, the LCD displays System Self-Test and the Test LEDs are illuminated. Test failures are displayed in the LCD window.

The self-test consists of the following tests:

Test Name	What it does . . .
Board level tests	<p>Each of the ESU 120e boards contains an on-board processor which executes the following series of tests checking the circuitry on the board:</p> <ul style="list-style-type: none"> • RAM tests; EPROM checksum • TS0 map tests • On board data path (sending a known test pattern through an on-board loop)
Unit level tests	<ul style="list-style-type: none"> • Front panel LED verification • Phase-Lock Loop verify • Board-to-board interface test <p>A test pattern is sent from the controller through a loopback on all other boards and is checked on the controller. This verifies the data path, clocks, and control signals.</p> <p>If a failure is detected, note the failure number prior to contacting ADTRAN Technical Support.</p> <p>The execution of self-test will disrupt normal data flow and prevent remote communication until the self-test is completed.</p>

Port Tests

The Port Tests menu is used to activate testing of specific data ports. It controls the activation of loopbacks and the initiation of data test patterns. Test results are displayed in the LCD window.



NOTE *The execution of Port Tests will disrupt normal data flow in the port being tested.*

Port Test Menu Items for 0.1 Nx56/64

0.1 Nx56/64 is the base Nx interface. It offers the following test functions:

LOOPBK

This initiates a loopback. The following options are available:

PRT/LCL The Nx port activates both a Local loopback (back toward the DTE) and a Port loopback when either is invoked.

REMOTE The remote loopback causes a V.54 code to be sent to the far end. The Nx at the far end activates a PRT/LCL loopback upon detection of the V.54 code.

OFF The loop is deactivated.



NOTE

The ESU 120e checks the remote loopback activation by detecting a proper response from the remote end. While waiting for the response, the display shows Looping. If successful, the display changes to Looped -Up. If unsuccessful, the display shows Failed.

511 PATT

Activates the generation of the 511 test pattern.

ON The pattern check circuitry is enabled and a test started. The test is ended by selecting OFF.

OFF The pattern generation and check is disabled.

DIS 511 RESULT

Displays the results of the 511 test indicated in the 511 option. The results are in the form of the number of errored seconds. The error count can be cleared by pressing the Clear key (shift+9).

Port Test Menu Items for 0.2 Drop

Loopback

Loopback activates the loopback function on the base Drop interface. The available loopbacks are a Port Loopback (towards the NI) and a Line Loopback (towards the PBX or other terminal equipment).

Cancel Tests

Use this menu selection to deactivate all active tests, including tests on option modules.

MAIN MENU

The Telnet/Terminal Main menu is the first menu displayed after the telnet/terminal session is established (see Figure 8-1). The default telnet/terminal password is ADTRAN.



NOTE Only one telnet/terminal session may be active at a time.

```
ADTRAN - ESU 120e
Password: XXXXXXXX

Main Menu

1) Status
2) Config
3) Util
4) Test
5) Management Config
6) Flash Download
7) Quit Session
```

Figure 8-1. Telnet/Terminal Main Menu

Status, Config, Util, and Test Menu Options

These menu items access the same modified menus that you can access through the front panel. For detailed information on the available menu options, see the following sections:

- Status Menu in Chapter 4
- Configuration Menu in Chapter 5
- Utility Menu in Chapter 6
- Test Menu in Chapter 7

TS0 Maps Configuration Menu

The Telnet/Terminal version of the TS0 maps configuration menu takes advantage of the 24-line VT 100 display. Upon entering this menu, the current Temp (temporary) map displays and is followed by nine selections that you can use for configuring and reviewing map information.

TEMP MAP			
DS0	PORT	DS0	PORT
1	IDLE	17	IDLE
2	IDLE	18	IDLE
3	IDLE	19	IDLE
4	IDLE	20	IDLE
5	IDLE	21	IDLE
6	IDLE	22	IDLE
7	IDLE	23	IDLE
8	IDLE	24	IDLE
9	IDLE	25	IDLE
10	IDLE	26	IDLE
11	IDLE	27	IDLE
12	IDLE	28	IDLE
13	IDLE	29	IDLE
14	IDLE	30	IDLE
15	IDLE	31	IDLE
16	IDLE		
1) COPY MAP A TO TEMP MAP			
2) COPY MAP B TO TEMP MAP			
3) CREATE TEMP MAP			
4) REVIEW MAP A			
5) REVIEW MAP B			
6) REVIEW TEMP MAP			
7) EDIT TEMP MAP			
8) APPLY TEMP MAP TO MAP A			
9) APPLY TEMP MAP TO MAP B			

Figure 8-2. TS0 Temp Map

You can use the Up and Down arrows or number keys to move the cursor from one selection to another. Use the Enter key to perform the action displayed in the LCD to the right of the cursor.

Normally, map configuration involves these steps. The first step is optional and consists of initializing the Temp map to one of three configurations (current Map A, current Map B, or all IDLES). Step 2 involves editing the Temp map so that it reflects the desired map configuration. Finally, step 3 replaces the current TS0 map A or B configuration with the Temp map configuration.

Initializing the Temp Map

Upon entering the TS0 maps configuration menu, the Temp map reflects its last configured state. You can then use selections 1 through 3 to initialize the displayed Temp map to one of three configurations. You can use selections 1 and 2 to initialize the Temp map from its current configuration to one which reflects the currently stored Map A or B configurations, respectively. Selection 3 initializes the Temp map to an all IDLE state.

Editing the Temp Map

If further changes to the Temp map are needed, use selection 7 to enter the Temp map edit mode. Upon entering this mode, the cursor location moves to TS0 number one in the TS0 field of the Temp map. The cursor may be moved from one TS0 to another using the Up and Down arrows until it is located at the TS0 number whose assigned port needs to be changed. At this point, pressing the Enter key causes the cursor to move into the Port field. The Up and Down arrows are then used to allow scrolling through the possible port selections. To restore the previous port assignment and return to the TS0 field, you may press the ESC key. Otherwise, press the Enter key to save the current selected port and return to the TS0 field. Once the cursor is again located in the Temp map TS0 field, pressing the ESC key a second time, causes the cursor to return to selection 1 below the Temp map display.

Applying the Temp Map

Once the Temp map reflects the desired configuration, use selections 8 or 9 to apply this configuration to Map A or B, respectively.

Reviewing Temp Maps

Selections 4 through 6 give a summary of the number of ports assigned to Map A, Map B, and the Temp map, respectively.

Remote Menu Access

Displays telnet menus for a remote device (may be another ESU/ TDU or any other ADTRAN product that supports telnet via its EIA-232 chain port). After selecting this option, the user may choose to connect to a device entered in the Unit Access Table or enter a unit ID for a unit not in the Unit Access Table. CTRL + X terminates the session and returns to the ESU 120e Main menu.

MANAGEMENT CONFIGURATION

This menu sets management information, such as SNMP community names and trap destination addresses.

SNMP Read Community

SNMP Read Community Name defaults to public. NMSs using this community name have Read access for all supported MIB objects but do not have the ability to change MIB objects. This value must be set to the same value on both the ESU 120e and the NMS (OpenView®, etc.) in order for the NMS to have Read access to MIBs supported by the ESU 120e. This value must be a text string of 16 characters or less.

SNMP Read/Write Community

SNMP NMS using this community name have full read/write access to all supported MIB objects (defaults to private). This setting must be the same value on both the ESU 120e and the NMS in order for the NMS to have read/write access to MIBS supported by the ESU 120e. This value must be a text string that is 16 characters or less.



To access other units external to the ESU 120e (proxied units) using an SNMP MIB browser, append a period and the unit ID of the external device to the Read Only and Read/Write community name used in the MIB Browser, for example public.4. See the Appendix B, Understanding SNMP for more information.

SNMP Trap Community

This community name is used for all SNMP traps forwarded by the ESU 120e. Traps received from daisy chained units have a period and the unit ID appended to the trap community name.

Host 1 Trap IP Address

The first of four entries for SNMP trap destination addresses. The ESU 120e forwards all SNMP traps to the IP address specified in this entry. If the address is set to the default value of 0.0.0.0, no traps are forwarded for this particular value.

Host 2 Trap IP Address

Defaults to 0.0.0.0. Second destination address for SNMP traps.

Host 3 Trap IP Address

Defaults to 0.0.0.0. Third destination address for SNMP traps.

Host 4 Trap IP Address

Defaults to 0.0.0.0. Fourth destination address for SNMP traps.

System Name

A text string that can uniquely identify an SNMP managed node.

System Contact

A text string containing the name, phone number, etc. of the individual responsible for maintaining an SNMP managed node.

System Location

A text string describing the physical location of an SNMP managed node (for example, SECOND FLOOR PBX ROOM).

Auth. Fail Traps Sent

(DISABLED, ENABLED: defaults to DISABLED)

When enabled, the ESU 120e issues an SNMP trap when any SNMP request is received with an invalid community name. Can be used for security purposes.

Poll Link Status Traps Sent

(DISABLED, ENABLED, defaults to DISABLED)

When enabled, the ESU 120e sends an SNMP trap whenever a device configured to be polled fails to respond. When the device begins responding to polls, a poll link-up trap is sent. The format of the traps are defined in the agent MIB.

Ping IP Host

Allows the user to Ping a specific IP address.

Telnet/Terminal Timeout

The ESU 120e terminates a telnet or terminal session if no activity is detected for this length of time. Only one telnet or terminal session may be active at one time. This timeout prevents an unattended session from blocking interactive access to the agent. The default value is five minutes.

Telnet/Terminal Password

This option allows modification of the password required for entry into a telnet or terminal session. The default value is ADTRAN.

Exit

Returns to the ESU 120e Main menu.

Flash Download

The ESU 120e uses flash memory that allows software updates via the EIA-232 port. This menu selection allows you to manually perform a flash download using XMODEM. T-Flash is also available to automate this process.

Quit Session

Terminates the telnet/terminal session.

Appendix A Understanding SNMP

As local area network (LAN) environments became standardized over the past ten years, multi-vendor equipment grew with competition. It became necessary to manage the various vendor equipment from a single control console. Thus, the SNMP emerged as the standard for managing commercial TCP/IP networks.

The term *SNMP* broadly refers to the message protocols used to exchange information between the network and the managed devices, as well as to the structure of network management databases.

SNMP BASIC COMPONENTS

SNMP has three basic components: Network Manager, Agent, and MIB.

Network Manager

This is a control program that collects, controls, and presents data pertinent to the operation of the network devices. It resides on a network management station.

Agent

This is a control program that responds to queries and commands from the network manager and returns requested information or invokes configuration changes initiated by the manager. It resides in each network device.

MIB

This is an index to the organized data within a network device. It defines the operating parameters that can be controlled or monitored. When requesting the network manager to retrieve or modify a particular piece of information about a network device, the network manager transmits the request to that network device. The agent in that device interprets the incoming request, performs the requested task, and sends its response to the network manager. The network manager collects all the data from the various network devices and presents it in a consistent form.

COMMANDS

Using SNMP Version 1, the network manager can issue three types of commands: `GetRequest`, `GetNextRequest`, and `SetRequest`.

GetRequest

This command retrieves a single item or the first in a series from a network device.

GetNextRequest

This command retrieves the next item in a series from a network device.

SetRequest

This command writes information to a network device.

MESSAGES

The network device issues two types of messages: **GetResponse** and **Trap**.

GetResponse

This message is the response to a network manager **GetRequest** or **GetNextRequest** command.

Trap

This is an unsolicited message issued by a network device to report an operational anomaly or an alarm condition to the network manager.

These messages are typically encased within informational packets and transported over the LAN or WAN (wide area network).

ESU 120E SNMP ACCESS

By default, SNMP MIB Browser access to the ESU 120e IP address with the configured community names, accesses the host. The ESU 120e can also act as an SNMP proxy agent for external units. To access MIB variables on externally chained devices, append a period and the Unit ID of the device to the Read and Read/Write community names. For example, if the Read community name configured in the ESU 120e is **public**, specifying "public.3" as the community name in the SNMP MIB Browser allows reading SNMP MIB variables from externally chained unit 3.

If the external unit's passcode is not the default, an entry must be added to the Unit Access Table for SNMP MIB access. See the Unit Access Table section in Chapter 3: Operation for more information. However, SNMP traps for the unit can be forwarded without the entry.

SNMP TRAP CONFIGURATION

Traps received by the ESU 120e from external units and the host unit are converted into SNMP traps and forwarded to the configured NMS. The source of the trap is uniquely identified at the NMS by a combination of the IP address of the ESU 120e, and the Unit ID of the sending device. The Unit ID is present in the trap packet appended to the end of the trap community packet name, for example **public.4**. It is also included as an Octet String variable (adProdPhysAddress) in the trap packet as defined in the individual product MIBs. The latest versions of the product MIBs, by default, display the appended trap community name in their descriptions.

Typical steps required for Management Station trap configuration are loading the device specific MIBs and loading or creating device-specific Trap Definition Files. The current product MIBs contain keywords embedded in comments that can be used by some network management platforms to automatically generate Trap Definitions. Otherwise, the descriptions may be used as a template for Trap Definitions.

If individual option card port and slot identification is required, it is present in the four- byte adProdPhysAddress field of the trap packet. The first two bytes are the Unit ID of the base controller (least significant byte first). The next two bytes are port and slot number. This field is the second object identifier in all traps sent from ESU/TDU products. For traps from the ISU 512, the Unit ID is the first object identifier. See the product MIBs for more information.

Definitions for Poll Link Up/Down traps are included in the ESU 120e MIB file: ESU 120e.MIB.

SNMP MIB BROWSER CONFIGURATION

The following steps are required to configure Network Manager MIB variable access through the ESU 120e:

1. Load the desired product MIBs on the network management station. If, for example, the administrator is managing ESU 120e and ISU 512 devices, load ESU 120e.MIB, ISU512.MIB, and RFC1406.MIB.
2. Create device entries in the NMS database for all units that are to be managed through the ESU 120e. The host unit should be configured as the Proxy agent for the external units. The IP address or host name used for the proxy designation is that of the ESU 120e.
3. Set community names in the device's entries for external units to the ESU 120e community name with the device Unit ID appended as defined in the previous section *ESU 120e SNMP ACCESS*.
4. Set the device timeout for all device entries in the NMS device database to five seconds, including the host unit.

SNMP MIB FILES

The ESU 120e supports several standard MIBs including MIB-II (RFC-1213), the DS1 E1/E1 MIB (RFC-1406), and the Ethernet MIB (RFC-1643). It also supports several ADTRAN enterprise-specific MIBs including the ADTRAN Product MIB (ADTRAN.MIB), the ADTRAN DS1 extensions MIB (ADS1.MIB), and all ESU/TDU Enterprise MIBs, such as ESU 120e.MIB.

The standard MIB files are usually included with most SNMP network management software. The latest version of the ADTRAN enterprise specific MIBs are available from the ADTRAN anonymous ftp site (<ftp.adtran.com>), or by dial-up from the BBS (205 - 971-8169). The MIB files are also located on the ADTRAN WWW site at <http://www.adtran.com>.

WIRING**Network interface Connector**

The network connections are as follows:

Connector type 15-pin female D connector

Table B-1. Network Pinouts

Pin	Name
1	Tx data (output)
2	Frame ground
3	Rx data (input)
4	Frame ground
5	Frame ground
7	Frame ground
9	Tx data (output)
11	Rx data (input)
6,8,10,12,13,14,15	Not Used

Control In/Chain In

This is used as an EIA-232 port for connection to a computer or modem (Control In) or to another ESU 120e for TSU 100 (Chain In). See Table B-2 for the pinout of the control/chain-in connector.

Connections

The chain-in connections are as follows:

Connector type	RJ-48
Part Number	AMP# 555164-2

Table B-2. Control In/Chain-in Pinout

Pin	Name	Description
1	GND	Ground-connected to unit chassis
2	RTS	Request to send - flow control
3	RXDATA	Data received by the ESU 120e
4	UNUSED	
5	TXDATA	Data transmitted by the ESU 120e
6, 7	UNUSED	
8	CTS	Clear to send - flow control

Chain Out

This is used to connect to another ESU 120e chain-in connector. See Table B-3 for the pinout of the chain-out connector.

Connections

The chain-out connections are as follows:

Connector type	RJ-48
Part Number	AMP# 555164-2

Table B-3. Chain-Out Connector Pinout

Pin	Name	Description
1	GND	Ground-connected to unit chassis. Connected to GND of next unit (pin 10)
2	UNUSED	
3	TX DATA	Data transmitted to chained units by the ESU 120e. Connect to RX DATA of the next unit (chain-in pin 3)
4	UNUSED	
5	RX DATA	Data received from chained units by the ESU 120e. Connect to TX Data of the next unit (chain-in pin 5)
6, 7,8	UNUSED	

Data Port Interface

Connector type 25-pin female D connector

Table B-4. Nx56/64 Pin Assignments for EIA-530 and V.36

Pin	EIA/CCITT	Description	Source
1	Shield		–
2	BA (A)/103	Transmitted Data (TD-A)	DTE
3	BB (A)/104	Received Data A (RD-A)	DCE
4	CA (A) /105	Request to Send A (RTS-A)	DTE
5	CB (A) /106	Clear to Send A (CTS-A)	DCE
6	CC (A)/107	DCE Ready (DSR-A)	DCE
7	AB /102	Signal Ground	DTE
8	CF (A) /109	Received Line Detector (DCD-A)	DCE
9	DD (B) /115	Receiver Element Timing (RC-B)	DCE
10	CF (B)/109	Received Line Detector (DCD-B)	DCE
11	DA (B) /113	External Clock B (ETC-B)	DTE
12	DB (B)/114	Transmit Element Timing (TC-B)	DCE
13	CB (B)/106	Clear to Send (CTS-B)	DCE
14	BA (B)/103	Transmitted Data (TD-B)	DTE
15	DB (A)/114	Transmit Element Timing (TC-A)	DCE
16	BB (B) /104	Received Data (RD-B)	DCE
17	DD (A) /115	Receiver Element Timing (RC-A)	DCE
18	Not supported		
19	CA (B)/105	Request to Send (RTS-B)	DTE
20	Not supported		
21	Not supported		
22	CC (B)/107	DCE Ready (DSR-B)	DCE
23	Not supported		
24	DA (A) /113	External Clock A (ETC-A)	DTE
25	Not supported		

Table B-5. Nx56/64 Pin Assignments for V.35 Mode

Pin	Name	CCITT	Description	Source
1	GND		Protective GND	–
2	TD-A	103	Tx Data A	DTE
3	RD-A	104	Rx Data A	DCE
4	RTS	105	RTS	DTE
5	CTS	106	CTS - Clear to Send	DCE
6	DSR	107	DSR - Data Set Ready	DCE
7	GND	102	Signal GND	DTE
8	DCD	109	Rec Line Det	DCE
9	RC-B	115	Rx Timing B	DCE
10			Not Used	
11	ETC-B	113	External Clock B	DTE
12	TC-B	114	Tx Timing B	DCE
13			Not Used	DCE
14	TD-A	103	Tx Data B	DTE
15	TC-A	114	Tx Timing A	DCE
16	RD-B	104	Rx Data B	DCE
17	RC-A	115	Rx Timing A	DCE
18			Not Supported	
19			Not Used	
20		108	Not Supported	
21			Not Supported	
22			Not Supported	
23			Not Used	
24	ETC-A	113	External Clk A	DTE
25			Not supported	

Table B-6. Adapter Cable, DB 25 to V.35, 34-Pin Winchester

Part # 1200285L1

DB25P Pin	34 Pin	Name
1	A	Protective GND
2	P	Tx Data A
3	R	Rx Data A
4	C	RTS or RR
5	D	CTS
6	E	DSR
7	B	Signal GND
8	F	Rec Line Sig Det (DCD)
9	X	Rx Signal Timing B
10		Not Connected
11	W	External Clock B
12	AA	Tx Signal Timing B
13		Not Connected
14	S	Tx Data B
15	Y	Tx Signal Timing A
16	T	Rx Data B
17	V	Rx Signal Timing A
18	J	Local Loopback
19		Not Connected
20	H	DTR
21	B	Remote Loopback
22		Not Connected
23		Not Connected
24	U	External Clk A
25	K	Test Mode

Table B-7. Nx56/64 Pin Assignments for V.11/x.21 Mode

Pin	Name	Description	Source
1		Protective GND	–
2	T(A)	Transmit A (TD-A)	DTE
3	R(A)	Receive A (RD-A)	DCE
4	C(A)	Control A (RTS-A)	DTE
5	I(A)	Indication A (CTS-A)	DCE
6		DSR-A	DCE
7	G	Signal GND	DTE
9	S(B)	Signal Timing B (RC-B)	DCE
11	X(B)	DTE Tx Signal Timing B (ETC-B)	DTE
13	I(B)	Indication B (CTS-B)	DCE
14	T(B)	Transmit B (TD-B)	DTE
16	R(B)	Receive B (RD-B)	DCE
17	S(A)	Signal Timing A (RC-A)	DCE
19	C(B)	Control B (RTS-B)	DTE
22		DSR-B	DCE
24	X(A)	DTE Tx Signal Timing (ETC-A)	DTE
Pins 8, 10, 12, 15, 20, 21,22,23,25 are not used in this mode			

Table B-8. Adapter Cable DB25 to X.21, DB15 Connector

Name	DB25Pin	DA15S Pin
Protective GND (Shield)	1	1
Signal GND	7	8
Control A	4	3
Control B	19	10
Indication A	8	5
Indication B	10	12
Transmit A	2	2
Transmit B	14	9
Receive A	3	4
Receive B	16	11
Signal Timing A	15/17	6
Signal Timing B	9/12	13

Base Drop (PBX)

The Drop has a DB-15 female connector as defined in Table B-9.

Table B-9. Pinout Connectors for Terminal Interface

Pin	Name
1	Rx Data (output)
2	Frame Ground
3	Tx data (input)
4	Frame Ground
9	Rx data (output)
11	Tx data (input)
5,6,7,8,10, 12, 13, 14,15	Not used

10BaseT

This is used to connect the ESU 120e to the local area network.

Connections

The required wiring connections are:

Connector type	Shielded RJ48
(USOC)Part Number	AMP # 555164-1

Table B-10. 10BaseT Pinout

Pin	Name (To Nic)
1	TX1
2	TX2
3	RX1
6	RX2

ALARM MESSAGES

This appendix lists and defines the alarm and status messages that appear on the ESU 120e screen.

Network Interface (NI)

Loss of Frame	NI unable to frame align with incoming FAS /NFAS framing pattern. Remote Alarm (Bit 3 of NFAS word) is transmitted out the network interface. AIS (unframed ones) is transmitted out the drop port.
Loss of TS16MF	NI unable to sync on TS16 multiframe signal. Valid only when CAS/TS16 framing enabled. Remote multiframe Alarm is transmitted out the network interface. ASI is transmitted out the drop port in TS16 only.
Remote Alarm	Remote alarm signal (Bit 3 of NFAS word) being received at network interface.
Remote MF Alarm	Remote multiframe alarm signal (Bit 6 of TS16 for three consecutive multiframe) being received at network interface.
AIS Received	Unframed ones being received at network interface. AIS transmitted out drop port interface.
TS16 AIS RCVD	Unframed ones being received in TS16 on network interface. Remote multiframe alarm transmitted out network interface. AIS in TS16 is transmitted out drop port.
Loss of CRC-4	NI unable to sync on CRC-4 multiframe signal. Valid only when CRC-4 framing is enabled. Remote Alarm is transmitted out the network interface. AIS is transmitted out the drop port.
Loss of Signal	No signal detected at NI

Nx56/64 Interface

The following messages indicate an alarm condition on the Nx56/64 card:

Clock Slip	Difference in frequency of the data clock at the network and DTE
PLL Alarm	Unable to achieve Phase Locked Loop on the clock provided by the network interface.
Zeros Alarm	All zeros (0s) data being sent toward the network interface
FIFO Alarm	Error in propagation of data through the FIFOs
No EXT Clock	No external transmit clock at DTE (only appears if EXT CLK is selected)

Drop Port Interface

The following messages indicate a condition on the Base Drop (PBX) interface:

Loss of Frame	Drop Port unable to frame align with incoming FAS/NFAS framing pattern. Remote Alarm (Bit 3 TS0 NFAS word) is transmitted on the drop port interface.
Loss of TS16 MF	Drop Port unable to sync on TS16 multiframe signal. Valid only when CAS/TS16 framing enabled. Remote multiframe Alarm is transmitted out the drop port interface. AIS is transmitted out the drop port in TS16 only.
Loss of CRC-4	Drop Port unable to sync on CRC-4 multiframe signal. Valid only when CRC-4 framing is enabled. Remote Alarm is transmitted out the drop port interface. AIS is transmitted out the drop port.
Loss of Signal	No signal detected at the drop port interface.
Remote Alarm	Remote alarm signal (Bit 3 of NFAS word) being received at drop port interface.
Remote MF Alarm	Remote multiframe alarm signal (Bit 6 of TS16 for three consecutive multiframes) being received at drop port interface.
AIS Received	Unframed ones being received at the Drop Port interface.
Frame Slip	Indicates clock being received at drop port is different frequency than network clock.
Excessive BER	Excessive Bit Error ratio. A bit error ratio of greater than 1×10^{-3} is being received at the Drop Port interface.

Status Messages

Network Interface (NI)

Payload On	Payload loopback activated
Line On	Loopback off
Loopback Off	All loopbacks deactivated
Factory Restore	Factory setting restored
Power On	Unit powered on
Self-Test	Internal self-test performed

Nx56/64 Interface

The following messages indicate the status of the Nx56/64 card:

Loop Up	Data is looped at both the network interface and DTE interface of the card
Remote Loop Up	Sending V.54 pattern in an attempt to loop up a remote device
511 Pattern On	Sending 511 pattern towards the network interface
Loop Down	Data is no longer looped back at the network interface or DTE interface
511 Pattern Off	No longer sending 511 pattern towards the network interface

Drop (PBX) Interface

The following messages indicate the status of the Drop interface:

Frame Slip	Indicates a Frame Slip has occurred on the Drop interface; this is present in Alarm History only
Line Loop Up	Line loopback activated
Port Loop Up	Port loopback activated
Loopdown	Loopback has been deactivated

ELECTRICAL SPECIFICATIONS

Network Interface

Electrical G.703

Framing G.704 CRC-4, FAS,CAS

Jitter G.823

Line Code HDB3

Mechanical 75 Ω - BNC; 120 Ω - DB15

Receiver Sensitivity -30dB

Nx56/64 Drop Port Interface

Nx56/64 (V.35 Interface)

Electrical	CCITT V.35 Synchronous, V.11 (x.21), EIA 530
Rates	56kbps - 1.984Mbps in 56k or 64k increments
Clock Options	Normal/Inverted and internal/external
Tests	Local Loopback (bilateral)
	Remote Loopback (V.54)
Test Pattern	511 with errored seconds display and error inject capability
Data inversion	Menu selectable
1s Density Protection	Force 1s to network after one second of consecutive zeros from DTE. User selectable (On/Off)
CTS, DCD, DSR	Normal or Force On
Connector	DB 25

Drop Port Interface

Electrical G.703	
Framing G.704	CRC-4, FAS,CAS
Jitter	G.823
Line Code	HDB3
Mechanical	120 Ω - DB15

Management Interfaces

Chain In/Out Ports

Interface Devices	PC Serial Port, Modem or SLIP connection to router
Interface Type	EIA-232
Data Rates	9600, 2400, 1200, 2400, 4800, 9600, 19200, 38400
Data Format	EIA-232 N81
Protocols	T-Watch/ADLP, ATEL/ADLP, TCP/IP/SLIP
Connector	RJ-45

10BaseT Interface

Interface	IEEE 802.3 Compliant
Rate	10 Mbps
Connector	RJ45
Receiver	Accepts signal > 300mV
Protocols	Network: IP
	Transport: TCP, UDP
	Service: SNMP, TELNET, ICMP, ARP, PING, T-WATCH

Option Slot Interface

Interface	ADTRAN proprietary, accepts ESU Option Modules.
-----------	---

Chassis Specifications

Height	Less than 3.5 inches (will fit in a 2U rack mount opening)
Width	Two units will fit within a 19-inch rack

Environmental Specifications

Input Power	90-250VAC, 50/60 Hz
Fuse	0.6A, 250V
Operating Temperature	0 deg C to 45 deg C
Max Power Consumption	15 Watts
Max Current	0.2 A

Index

Numerics

- 0.1 Nx56/64 Port Configuration (Port Config) Menu Items 5-17
- 0.2 DSX-1 Port Configuration (Port Config) Menu Items 5-19
- 10BASET Interface D-3
- 10BaseT Interface 2-6
- 10BaseT Pinout B-9

A

- Adapter Cable DB25 to X.21, Db15 Connector B-8
- Adapter Cable, DB 25 to V.35, 34-Pin Winchester B-6
- ADTRAN Shipments Include 2-1
- ADTRAN Web Site iii
- alarm and status messages on ESU 120e screen C-1
- alarm,clear port 4-6
- applications, ESU 120e 1-3

B

- board level tests 2-7

C

- Cancel Key, ESU 120e front panel 3-1
- Chain In/Out Ports D-3
- Chain Port Output 2-6
- Chain-Out Connector Pinout B-3
- change/set a passcode, how to 6-3
- Chassis Specifications, ESU 120e D-4
- Commands, SNMP A-2
- Config, front panel menu option 3-8
- Configuration Menu Tree 5-2
- Control In/Chain-in Pinout B-2
- Control Port Input 2-6
- CSU Status, LEDs 3-3
- customer service ix

D

- data port identification 3-7
- Drop (PBX) Interface 2-6
- Drop (PBX) Interface, status messages C-4
- Drop Port Interface, specifications D-2
- Drop Port Interface, system

messages C-3

DSU/Drop Status 3-3

DTE timing 5-7

E

electrical specifications for ESU
120e D-1

E-mail, for Y2K info iii

Enter Key, ESU 120e front panel
3-1

Enter Passcode from Other Menus,
how to 6-2

Environmental Specifications D-4

Equipment customer provides 2-1

errors, network interface 4-3

ESU 120e Clock Sources 5-5

ESU 120e Configuration
Applications 1-3

ESU 120e Features 1-2

ESU 120e Overview 1-1

ESU 120e snmp access A-3

ESU Option Modules 1-2

ESU120e Interfaces 2-5

Example 2-8

F

Faxback Document Line, Y2K iii
front panel LCDs of main menu,
descriptions 3-8

Front Panel Menu Structure 3-7

Front Panel, operation 3-1

G

Grounding 2-2

Grounding Instructions for ESU
120e 2-2

I

Initialization 2-7

L

LCD Window, ESU 120e front
panel 3-1

LED Descriptions, ESU 120e front
panel 3-3

M

Management Interfaces D-3

map xchgng 5-13

menu items for map exchange

menu 5-13

Messages, network device for
SNMP A-3

N

Network 7-2

Network (NI) Menu Items 5-3

Network Interface, status
messages C-4

Network Interfaces 2-5

network performance reports 4-2

Network Pinout B-1

Network Test Interface 2-5

network, interface errors 4-3

network, NI 5-3

NI ERRORS 4-3

Normal Power-Up Procedure 2-9

Numeric Keypad, ESU 120e front
panel 3-1

Nx56/64 (V.35 Interface),
specifications D-2

Nx56/64 Interface, alarm message

C-2
 Nx56/64 Interface, status messages C-4
 Nx56/64 Pin Assignments for EIA-530 Mode B-4, B-5
 Nx56/64 Pin Assignments for V.11/x.21 Mode B-7
 Nx56/64 Serial Interface 2-5

O

Option module architecture for ESU 120e 1-3
 Option Slot Interface D-3

P

passcode, special features 6-3
 Pinout Connectors for Terminal Interface B-8
 port configuration 5-17
 port status 4-5
 port utility 6-5
 power connection 2-2
 power cord 2-2
 power up, normal procedure 2-9
 power-up testing 2-6
 Product Matrix, Y2K info iii

R

Rear Panel layout 2-4
 remote port 4-6
 Router, PBX, Video Application Set Up 1-3

S

self test 7-2

self-testing at power up 2-6
 Set Passcode, how to 6-2
 setting unit identification, how to 6-4
 Setting up ESU 120e to work with T-Watch PRO over EIA-232 connection 3-9
 Setting up ESU 120e to work with T-Watch PRO over LAN 3-9
 Shift, ESU 120e front panel 3-1
 shipping damages, what to do 2-1
 SNMP Basic Components A-1
 SNMP mib browser configuration A-5
 SNMP MIB Files A-5
 SNMP TRAP CONFIGURATION A-4
 Status Menu Tree 4-1
 Status Messages for ESU 120e C-4
 Status, front panel menu option 3-8

T

Telnet, connect to ESU 120e with 3-10
 Telnet/Terminal Main menu 8-1
 Terminal Mode, configuring and monitoring unit 3-10
 Test Menu Tree 7-1
 Test, front panel menu option 3-8
 timing
 DTE 5-7
 T-Watch PRO 3-8
 T-Watch PRO, capabilities 3-8

U

Unit 5-11

unit ID 6-4
unit level tests 2-7
Unit menu 5-11
Unpack 2-1
unpack, inspect, power up 2-1
Up and Down Arrows, ESU 120e
front panel 3-1
Using SNMP with ESU 120e 3-10
Util, front panel menu option 3-8
Utility Menu Tree 6-1

W

Warranty and customer service ix
Wiring, Connector Pinouts B-1

Y

Y2K Project Line iii
Y2K Readiness Disclosure iii
Y2K, Faxback Document Line iii

Product Support Information

Presales Inquiries and Applications Support

Please contact your local distributor, ADTRAN Applications Engineering, or ADTRAN Sales:

Applications Engineering (800) 615-1176

Sales (800) 827-0807

Post-Sale Support

Please contact your local distributor first. If your local distributor cannot help, please contact ADTRAN Technical Support and have the unit serial number available.

Technical Support (888) 4ADTRAN

Repair and Return

If ADTRAN Technical Support determines that a repair is needed, Technical Support will coordinate with the Customer and Product Service (CaPS) department to issue an RMA number. For information regarding equipment currently in house or possible fees associated with repair, contact CaPS directly at the following number:

CaPS Department (256) 963-8722

Identify the RMA number clearly on the package (below address), and return to the following address:

ADTRAN, Inc.
CaPS Department
6767 Old Madison Pike
Progress Center
Building #6, Suite 690
Huntsville, AL 35807

RMA # _____

Free Manuals Download Website

<http://myh66.com>

<http://usermanuals.us>

<http://www.somanuals.com>

<http://www.4manuals.cc>

<http://www.manual-lib.com>

<http://www.404manual.com>

<http://www.luxmanual.com>

<http://aubethermostatmanual.com>

Golf course search by state

<http://golfingnear.com>

Email search by domain

<http://emailbydomain.com>

Auto manuals search

<http://auto.somanuals.com>

TV manuals search

<http://tv.somanuals.com>