

D4 U-BR1TE V w/PWR and DDS Loopbacks ISDN 2B1Q Interface Installation and Maintenance

CONTENTS

1. GENERAL	1
2. INSTALLATION	2
3. TESTING	7
4. MAINTENANCE	13
5. WARRANTY AND CUSTOMER SERVICE	14

FIGURES

Figure 1. ADTRAN U-BR1TE V	1
Figure 2. Backplane Pin Assignments	3
Figure 3. Time Slot Assignments for 2B+D Service in SLC Mode I w/ DID Counting	3
Figure 4. Time Slots that CANNOT Contain BR1TE Cards	4
Figure 5. SW1, SW3, and SW6 Labeling	4
Figure 6. Position Switch Settings at Network Locations for ISDN Applications	6
Figure 7. U-BR1TE V IDSL/DDS Circuit Diagram	10
Figure 8. IDSL/DDS Loopback Response	11
Figure 9. ADTRAN U-BR1TE Bidirectional Loopback ..	12
Figure 10. IDSL/DDS Remote End Initiated Loopback, Local Loop	12
Figure 11. IDSL/DDS Remote End Initiated Loopback, Customer Loop	12
Figure 12. IDSL/DDS Trouble Codes	13
Figure 13. DS0 Latching Loopback	14

TABLES

Table 1. SW1, SW3, and SW6 Option Settings	5
Table 2. Rotary Switch Options	7
Table 3. LED Indication	7

1. GENERAL

This practice provides installation and maintenance procedures for the ADTRAN D4 U-BR1TE V w/PWR and DDS Loopbacks, P/N 1104020L4. **Figure 1** is an illustration of the U-BR1TE V.

ISDN/DDS

The U-BR1TE employs features for both ISDN and DDS transport. ISDN comprises the major functionality and is described in this section. A description of DDS functionality is located in Section 3.

Revision History

Issue 3 of this document includes 2B leased mode operation and revises the CLEI code.

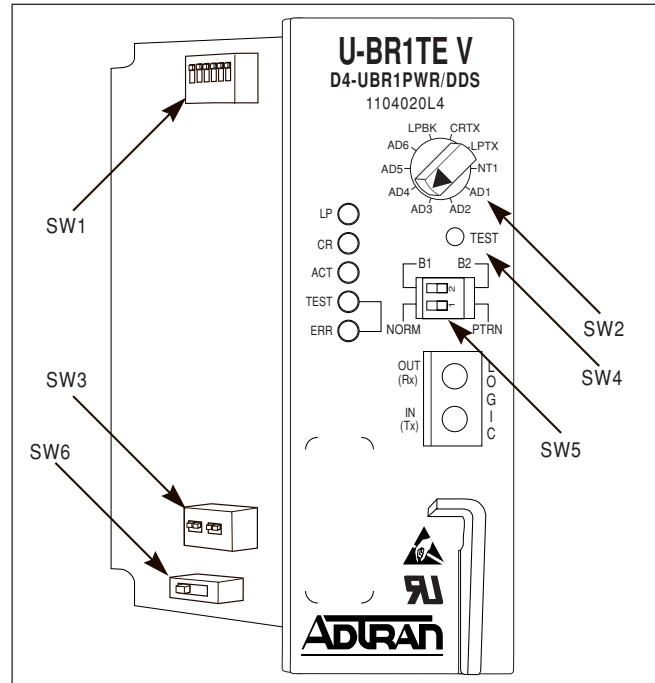

Figure 1. ADTRAN U-BR1TE V

Functional Description

The U-BR1TE V is a line card that plugs into a single channel slot of an AT&T D4/SLC[®]-96 channel bank. It provides an ISDN U-interface and allows the transport of Basic Rate 2B+D information over T1 carriers and twisted pair wiring. The U-BR1TE V combines the functionality of a standard U-BR1TE V and a U-Repeater Powering Module which will simplify the installation of the U-Repeater. Span powering also allows deployment of 2-wire DDS when an IDSL OCU-R is used to terminate the ISDN local loop. This eliminates the need to provide AC power at the customer premises.

The U-BR1TE V is used at both the Central Office Terminal and Remote Terminal locations. Clear channel capability (B8ZS) is not required of the T1 facility if zero byte substitution is enabled. The U-BR1TE V plugs into a single channel slot of the D4 bank, but can require three time slots when transporting 2B+D information. Block error rate performance over the T1 facility is monitored and is available to the network.

Features

The U-BR1TE V features support both ISDN and DDS, plus features common to both as listed here:

ISDN Features

- Span powers U-repeaters with 43 mA @ -28 to -120 VDC for ISDN applications.
- Internal test pattern allows for testing of individual B Channels without requiring external test equipment.
- Transportation of ISDN Basic Rate 2B+D information over T1 facilities in the 3-DS0 format specified in TR-NWT-000397.
- B1 and B2 loopback addressability at the front panel for the NT1 and up to six devices in the Network-to-Customer direction.

DDS Features

- Span powers an IDSL OCU-R with 12 mA @ -120 VDC for DDS applications.
- Transmit MUX-Out-of-Sync (MOS) trouble code upstream for IDSL loss of signal, loss of sync, or open loop.
- Perform bidirectional loopback (loop and network) when commanded into DS0 DP loopback from the network direction only.
- Initiate in-band OCU loopback to loop the IDSL OCU-R via front panel push button.
- Loopback release in response to TIPs per TR62310 or front panel push button.
- Remap all subsequent DS0 DP loopback codes into respective EOC loopbacks to loop back respective downstream U-Repeater, TRISDN elements, and U-BR1TES when optioned for 1B+D, or 2B+D.
- Pass OCU loopback code through to loop the IDSL OCU-R.
- Pass CSU loopback code through to loop the CSU/DSU and simultaneously send a remap to the NT1 EOC address.
- Returns Abnormal Station Code (ASC) to the network in B1 during loopback conditions initiated by the IDSL OCU-R.

2B Leased Mode Features

- DDS loopback operation during 2B data mode only.

Common Features

- ISDN 2B1Q interface which meets all Layer 1 requirements as specified in ANSI T1.601-1991.
- 18 kft nominal range on mixed gauge wire.

- All Layer 1 maintenance function and performance monitoring as specified in TR-NWT-000397 and TR-TSY-000829.
- Distinctive metallic DC test signature to identify either line unit LT or line unit NT mode of operation as specified in TR-NWT-0000397.
- Provides loopback capability for full 2B+D as well as individual B channels in both loop and carrier directions. Individual B channel loopbacks may be initiated at the U-BR1TE V front panel or from a remote location through the maintenance channel.
- DS0 logic level transmit and receive data access through front panel bantam jacks.
- A built-in Cyclic Redundancy Check (*crc*) clock error detector allows for local performance monitoring at the front panel without test equipment.
- Addressing and error status with front panel LED indicators. Test function chosen by a front panel ten-position rotary switch.

The U-BR1TE V is compatible in functionality and is interchangeable with the U-BR1TE III w/PWR (1103020L4) except when used in DDS applications. In addition to being compatible and interchangeable with the just mentioned ADTRAN unit, the U-BR1TE V, adds features in leased mode, including DS0 DP latching loopback and sending Multiplexer-Out-of-Sync (MOS) toward the network.

2. INSTALLATION



After unpacking the unit, inspect it for damage. If damage is noted, file a claim with the carrier, then contact ADTRAN. See *Warranty and Customer Service*.

Physical Requirements

The U-BR1TE V plugs into a single D4/SLC-96 channel slot. The backplane pin assignments are illustrated in **Figure 2**. When provisioned for basic rate service (2B+D), the U-BR1TE V occupies three time slots. In a D4 or SLC-96 Mode III channel bank, it occupies the time slot associated with the physical channel slot that it occupies plus the next two time slots to the right. The physical channel slots, whose time slots are used in this manner, must remain unoccupied.

See **Figure 4** for additional channel slot deployment restrictions for each bank type.

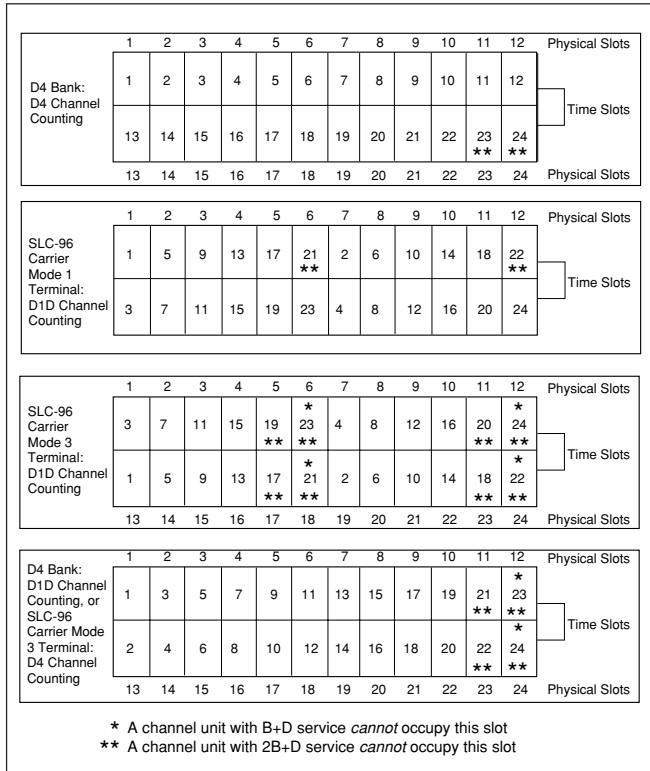

Figure 4. Time Slots that CANNOT Contain BR1TE Cards

D4 Bank Requirements

The COT D4 bank must be configured with an OIU-2 selected for external timing. The COT bank must be provided with an external composite clock synchronized with the network.

SLC-96 Bank Requirements

The COT SLC-96 bank must be configured with a special service unit (SSU) selected for external timing. The COT SLC-96 bank must be provided with an external composite clock synchronized with the network.

Interface Requirements

The U-BR1TE V unit includes two interfaces. The loop-side interface is an ISDN U-interface which is used to deliver Basic Rate service. The carrier-side interface is a D4/SLC-96 channel bank interface which is used to insert data into the 1.544 Mbps T1 stream. Only the polarity-insensitive T and R leads are used in the cross-connection.

Option Switch Settings

Figure 5 displays the locations for SW1, SW3, and SW6 on the U-BR1TE V. **Table 1** contains the option settings for SW1, SW3, and SW6 of the U-BR1TE V.

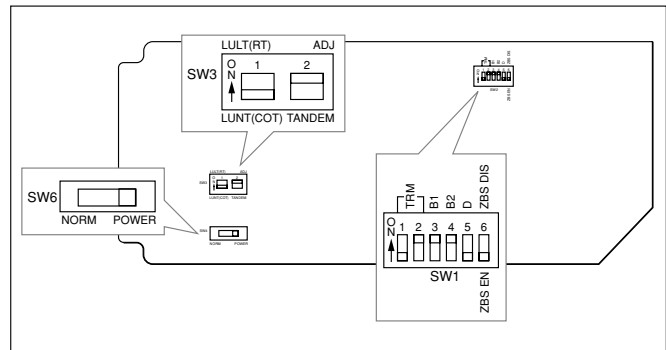

Figure 5. SW1, SW3, and SW6 Labeling

Table 1. SW1, SW3, and SW6 Option Settings

Switch	Label	Function	Description																																								
SW1-1 SW1-2	TRM TRM	Bank Type Selection	<p>Selects the bank type for the U-BR1TE V.</p> <table border="1"> <thead> <tr> <th>Bank</th> <th>Count/Slot</th> <th>SW1-1</th> <th>SW1-2</th> </tr> </thead> <tbody> <tr> <td rowspan="2">D4</td> <td>D4 Counting</td> <td>On</td> <td>Off</td> </tr> <tr> <td>D1D Counting</td> <td>On</td> <td>On</td> </tr> <tr> <td rowspan="2">SLC I</td> <td>CU in slots 1, 4, 7, 10</td> <td>On</td> <td>On</td> </tr> <tr> <td>CU in slots 2, 5, 8, 11</td> <td>Off</td> <td>Off</td> </tr> <tr> <td rowspan="2">SLC III</td> <td>D4 Counting</td> <td>On</td> <td>On</td> </tr> <tr> <td>D1D Counting</td> <td>Off</td> <td>On</td> </tr> </tbody> </table>	Bank	Count/Slot	SW1-1	SW1-2	D4	D4 Counting	On	Off	D1D Counting	On	On	SLC I	CU in slots 1, 4, 7, 10	On	On	CU in slots 2, 5, 8, 11	Off	Off	SLC III	D4 Counting	On	On	D1D Counting	Off	On															
Bank	Count/Slot	SW1-1	SW1-2																																								
D4	D4 Counting	On	Off																																								
	D1D Counting	On	On																																								
SLC I	CU in slots 1, 4, 7, 10	On	On																																								
	CU in slots 2, 5, 8, 11	Off	Off																																								
SLC III	D4 Counting	On	On																																								
	D1D Counting	Off	On																																								
SW1-3 SW1-4 SW1-5	B1 B2 D	Service Level Selection	<p>Selects the service level. The U-BR1TE V may be optioned to deliver full ISDN (2B+D) or any of the following levels of service.</p> <table border="1"> <thead> <tr> <th>Type</th> <th>Service Option</th> <th>SW1-3 (B1)</th> <th>SW1-4 (B2)</th> <th>SW1-5 (D)</th> </tr> </thead> <tbody> <tr> <td>ISDN</td> <td>2B+D</td> <td>On</td> <td>On</td> <td>On</td> </tr> <tr> <td>Leased (128 kbps)</td> <td>2B</td> <td>On</td> <td>On</td> <td>Off</td> </tr> <tr> <td>ISDN/DDS</td> <td>B1+D</td> <td>On</td> <td>Off</td> <td>On</td> </tr> <tr> <td>ISDN</td> <td>B2+D</td> <td>Off</td> <td>On</td> <td>On</td> </tr> <tr> <td>DDS/Leased</td> <td>B1</td> <td>On</td> <td>Off</td> <td>Off</td> </tr> <tr> <td>Leased</td> <td>B2</td> <td>Off</td> <td>On</td> <td>Off</td> </tr> <tr> <td>ISDN</td> <td>D</td> <td>Off</td> <td>Off</td> <td>On</td> </tr> </tbody> </table>	Type	Service Option	SW1-3 (B1)	SW1-4 (B2)	SW1-5 (D)	ISDN	2B+D	On	On	On	Leased (128 kbps)	2B	On	On	Off	ISDN/DDS	B1+D	On	Off	On	ISDN	B2+D	Off	On	On	DDS/Leased	B1	On	Off	Off	Leased	B2	Off	On	Off	ISDN	D	Off	Off	On
Type	Service Option	SW1-3 (B1)	SW1-4 (B2)	SW1-5 (D)																																							
ISDN	2B+D	On	On	On																																							
Leased (128 kbps)	2B	On	On	Off																																							
ISDN/DDS	B1+D	On	Off	On																																							
ISDN	B2+D	Off	On	On																																							
DDS/Leased	B1	On	Off	Off																																							
Leased	B2	Off	On	Off																																							
ISDN	D	Off	Off	On																																							
SW1-6	ZBS DIS ZBS EN	Zero Byte Substitution	<p>In 2B+D, B1+D, or B2+D the ZBS option must be set the same for the COT and RT. SW1-6 should be set toward "ZBS EN" for AMI-provisioned carriers. The switch setting is optional for B8ZS-provisioned carriers. In non-D channel modes, ZBS must be disabled when DDS service rate is 64 kbps, or 56 kbps with secondary channel. Consult local provisioning guidelines.</p> <p>On Disables ZBS Off Enables ZBS</p>																																								
SW3-1	LULT (RT) LUNT (COT)	Termination Mode	<p>This switch should be set toward "LULT" when the unit is installed as Adjacent-to U-Repeater, Adjacent-to-Customer, or Tandem Office Source configuration. This switch should be set toward "LUNT" for Adjacent-to-Switch and Tandem Office Sink configurations.</p> <p>On LULT Mode (RT typical) Off LUNT Mode (COT typical) (See Figure 6)</p>																																								
SW3-2	ADJ TANDEM	<p><i>Function dependent upon SW3-1 setting.</i></p> <p>LULT Mode (SW3-1 On) DC sealing current provided DC sealing current not provided</p>	<p>In the LULT(RT) mode, SW3-2 controls sealing current. When used in an Adjacent-to-Customer configuration, sealing current should be provided (SW3-2 On). In a Tandem Office Source configuration, sealing current is not required, and should be disabled (SW3-2 Off).</p>																																								
	ADJ TANDEM	<p>LUNT Mode (SW3-1 Off) Periodic wake-up tone not provided Periodic wake-up tone provided</p>	<p>In the LUNT(COT) mode, SW3-2 controls periodic wake-up tone. Periodic wake-up tones should be disabled when located in an Adjacent-to-Switch location (SW3-2 On). Periodic wake-up tones are required (SW3-2 Off) when located in a Tandem Office Sink configuration, or when adjacent to a device requiring wake-up tones, such as a Newbridge switch.</p>																																								
SW6	POWER	Powering provided toward the customer U-interface.	<p>Automatically determines which of the following modes of operation is appropriate;</p> <ul style="list-style-type: none"> Supply a constant 43 mA to power an ADTRAN ISDN U-Repeater II, U-Repeater III. Supply a constant -120 Vdc to power an ADTRAN IDSL OCU-R. 																																								
	NORM	Normal	No powering provided toward the customer U-interface.																																								
<p>Note: Power option should only be used in the LULT (RT) configuration.</p>																																											

Figure 6 displays the position switch settings at network locations.

Front Panel Features

The U-BR1TE V front panel features a two position DIP switch, a recessed pushbutton, a rotary switch, a bantam jack, and LEDs, as illustrated in Figure 1. The B1/B2 DIP Switch selects the desired bearer channel, B1 or B2, to be tested during local tests using the U-BR1TE V front panel.

The NORM/PTRN DIP Switch is recessed to prevent inadvertent operation. The ten-position rotary switch is used to determine the specific test that will be performed, including downstream loopbacks (see Table 2).

LED indicators display current status of the unit, as listed in Table 3.

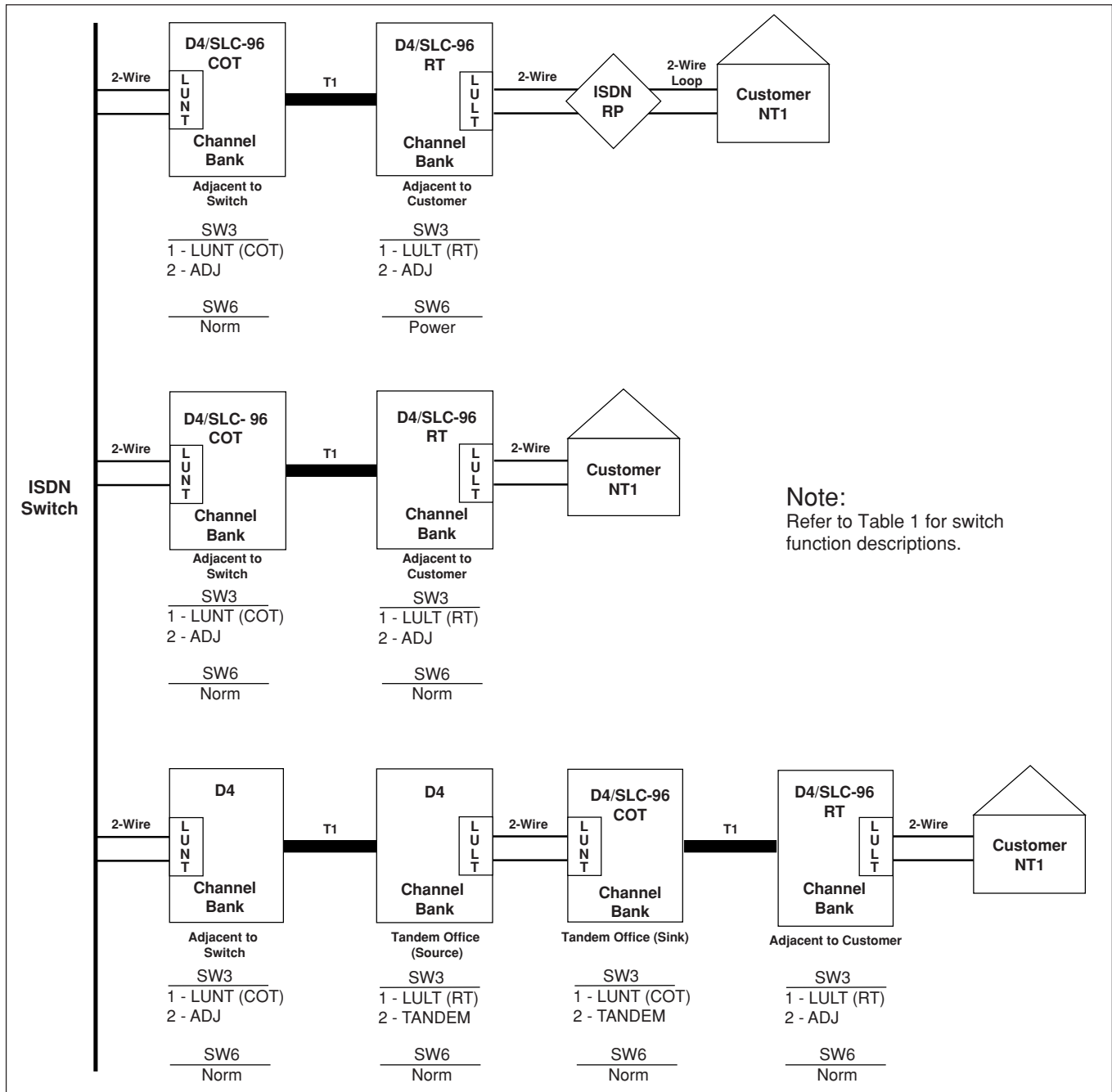

Figure 6. Position Switch Settings at Network Locations for ISDN Applications

Table 2. Rotary Switch Options

Display	Interpretation
AD1	Address #1, address of this unit
AD2	Address #2, the next downstream unit away
AD3	Address #3, the second unit downstream
AD4	Address #4, the third unit downstream
AD5	Address #5, the fourth unit downstream
AD6	Address #6, the fifth unit downstream
LPBK	Loopback, forces this unit to loopback the selected B1 or B2 channel. Loopbacks occur in both the customer and network directions.
CRTX	Carrier transmit, in the carrier direction
LPTX	Loop transmit, in the loop direction
NT1	NT1, address of the NT1 Latching OCU in DDS mode

3. TESTING

The U-BR1TE V responds to embedded operation channel loopbacks, including B1, B2, and 2B+D, when configured for D channel operation. When used in B1 configuration (non-D channel modes of operation) the U-BR1TE V will respond to an in-band DS0 DP latching loopback sequence. When remote testing is not available, or during isolation of trouble or equipment malfunction, the U-BR1TE V front panel provides local test capabilities. Using the internal 2047 pseudorandom test pattern generator or the bantam jacks allows craft personnel to test in both the downstream and upstream directions, including loopback for 6 addressable ISDN devices and the customer's NT1.

Table 3. LED Indication

Indicator	Color	Description
Loop Status (LP)	Off	Indicates loop synchronization has been established and no Near End Block Errors (NEBE) are being received from the Loop interface.
	Red	Illuminated when U-interface is out of sync or has a loss of signal.
	Yellow	Flashes yellow upon receipt of a NEBE. During Local Performance Monitoring (see <i>Testing</i>) will flash yellow when BER > 10 ⁻⁶ is detected and illuminate yellow when a BER > 10 ⁻⁵ is detected.
Carrier Status (CR)	Off	Indicates carrier synchronization (framing per TR-TSY-000397) has been established and no Near End Block Errors (NEBE) are being received from the Carrier interface.
	Red	Illuminated when no framing pattern is received.
	Yellow	Flashes yellow upon receipt of a NEBE. During Local Performance Monitoring (see TESTING) will flash when a BER > 10 ⁻⁶ is detected and illuminate yellow when a BER > 10 ⁻⁵ is detected.
Activation (ACT)	Green	ISDN Application - Indicates that the terminal equipment has exchanged ACT bits with the ISDN switch. DDS Application - Indicates loop is terminated with an OCU-R. ISDN Application - Once per second indicates that the ACT bit is being sent in one direction only.
Test (TST)	Yellow	Solid yellow when a front panel test has been successfully initiated or when responding to a 2B+D loopback request. Flashes yellow once every two seconds when responding to a B1 loopback request or when forced into a B1 loopback from the front panel. Flashes yellow twice every two seconds when responding to a B2 loopback request or when forced into a B2 loopback from the front panel.
	Green	Solid Green when in Local Performance Monitoring or when the local test pattern gen/det is invoked.
Error (ERR)	Red	Flashes red when errors are seen by local test pattern detector.

The front panel bantam jacks accommodate standard DS0 Logic Testers such as the TPI 108/109 RT II or FIREBERD 4000/6000 which perform both the upstream and downstream testing.

NOTE

On DDS circuits the internal 2047 Pattern Generator on the U-BR1TE V should be used only when the service is operating at 64 kbps. If DDS service is operating at 56 kbps or less, the U-BR1TE V will display errors if the internal 2047 Pattern Generator is used. The use of external DDS test equipment is required for all data rates at 56 kbps and below.

Loopback Tests (ADR1 - ADR6, NT1)

Loopbacks in the Network-to-Customer direction can be initiated from either the ISDN switch or the front panel. Either the internal 2047 test pattern or a DS0 digital test set provide the 64 kbps test pattern to be tested in B1 or B2. When initiating loopbacks from the U-BR1TE V front panel, the downstream direction is automatically selected based on the card position in the network.

To initiate a loopback using the internal 2047 test pattern, perform the following:

1. Select the desired loopback address using the ten-position rotary switch. See Table 2.
2. Select the desired bearer channel using the B1/B2 DIP switch.
3. Select PTRN on the NORM/PTRN DIP switch.
4. Depress the recessed TEST pushbutton to initiate the test. The TEST LED will illuminate GREEN when the loopback is established to the selected address, and the ERR LED should go out following synchronization to the test pattern. If the selected address does not respond, the TEST LED will remain out and the ERR LED will illuminate.
5. To insert one bit error, momentarily (for less than two seconds) depress the TEST pushbutton. The ERR LED should flash upon receipt of the injected error.
6. Tests to additional network addresses may be performed by changing the selector knob to the desired address. It is not necessary to exit the test mode to select a new address.

7. To deactivate the loopback, depress the TEST pushbutton for two seconds, until the GREEN TEST LED is extinguished, or select NORM on the NORM/PTRN DIP switch.

To initiate a loopback at any data rate when using an external DS0 digital test set, perform the following:

1. Insert the TX and RX bantam plug of the DS0 digital test set into the U-BR1TE V respective front panel bantam jacks. Connect the clock input of the DS0 digital test set to the channel bank's clock source (the D4 OIU, or the SLC-96 SSU). Configure the test set for Near Logic and 64 kbps.
2. Select the desired loopback address using the ten-position rotary switch. See Table 2.
3. Select the desired bearer channel using the B1/B2 DIP switch.
4. Depress the recessed TEST pushbutton to initiate the test. The TEST LED will illuminate YELLOW when the loopback is established to the selected address. If the selected address does not respond, the TEST LED will remain off. Observe the DS0 digital test set for bit errors.
5. Tests to additional network addresses may be performed by changing the selector knob to the desired address. It is not necessary to exit the test mode to select a new address.
6. To deactivate the loopback, depress the TEST pushbutton or remove the transmit bantam plug. Upon deactivation of the test, the TEST LED will go out.

Point-to-Point Test (CRTX, LPTX)

A point-to-point (straight-away) test can be performed to either the U-interface (LPTX) or the T-1 carrier interface (CRTX). In both cases, either the internal 2047 test pattern generator or a DS0 DP digital test set is used to verify the performance of the selected bearer channel.

To initiate a point-to-point test using the internal 2047 test pattern, perform the following:

1. Select the desired test direction, LPTX or CRTX, using the ten-position rotary switch. See Table 2.
2. Select the desired bearer channel using the B1/B2 DIP switch.
3. Select PTRN on the NORM/PTRN DIP switch.

4. Depress the recessed TEST pushbutton to initiate the test. The TEST LED will illuminate GREEN and the ERR LED should go out following synchronization to the test pattern from the far end.
5. If the far end unit is a U-BR1TE V using the internal 2047 test pattern, perform steps 1 through 4, choosing the same front panel switch setting. If the far end is a test set, ensure it is configured for a 2047 test pattern.
6. To insert one bit error, momentarily (for less than two seconds) depress the TEST pushbutton. Bit errors will be seen at the far end test unit.
7. To deactivate the loopback, depress the TEST pushbutton for two seconds, until the GREEN TEST LED is extinguished, or select NORM on the NORM/PTRN DIP switch. Upon deactivation of the test, the TEST LED will go out.

To initiate a point-to-point test using an external DS0 digital test set, perform the following:

1. Insert the TX and RX bantam plug of the DS0 digital test set into the U-BR1TE V respective front panel bantam jacks. Connect the clock input of the DS0 digital test set to the channel banks clock source (D4's OIU, or the SLC-96 SSU). Configure the test set for Near Logic and 64 kbps.
2. Select the desired test direction, LPTX or CRTX, using the ten-position rotary switch. Refer to Table 2.
3. Select the desired bearer channel using the B1/B2 DIP switch.
4. Depress the recessed TEST pushbutton to initiate the test. The TEST LED will illuminate YELLOW.
5. If the far end unit is a U-BR1TE V using a DS0 digital test set, perform steps 1 through 4, choosing the same front panel switch setting. Ensure that both test sets are configured for the same test pattern (511, 2047). If the far end unit is a U-BR1TE V using the internal 2047 test pattern, perform steps 1 through 4 of the previous section.
6. Observe the DS0 digital test set for bit errors.
7. To deactivate the loopback, depress the TEST pushbutton, or remove the transmit bantam plug. Upon deactivation of the test, the TEST LED will go out.

Local Loopback (LPBK)

A bilateral loopback can be initiated from the U-BR1TE V front panel for either bearer channel. A local test pattern source is not required for this test. To initiate a local loopback, perform the following:

1. Select the desired bearer channel using the B1/B2 DIP switch.
2. Select LPBK using the ten-position rotary switch. See Table 2.
3. Depress the recessed TEST pushbutton to initiate the test. The TEST LED will illuminate YELLOW.
4. To deactivate the loopback, depress the TEST pushbutton. Upon deactivation of the test, the TEST LED will go out.

Local Performance Monitoring

Performance Monitoring of the local T1 carrier system and 2-wire U-interface of the ISDN data can be performed from the front panel without interruption of service to the customer. For this test, bearer channel selection is not applicable and a test pattern source is not required. To initiate a local performance monitoring session, perform the following:

1. Ensure the NORM/PTRN DIP switch is in the NORM position, and that a bantam plug is NOT installed in the front panel TX bantam jack.
2. Select ADR1 using the ten-position rotary switch.
3. Depress the recessed TEST pushbutton to initiate the test. The TEST LED will illuminate GREEN.
4. The total number of Near End Block Errors (NEBE) received are simultaneously displayed as crc errors with the LP and CR CRC status LEDs. (See Table 3).
5. To exit local performance monitoring, depress the TEST button for two seconds or longer. Upon deactivation of the test, the TEST LED will go out.

ISDL/DDS Description

The U-BR1TE V may be deployed in the adjacent to customer position to provide transport for DDS/Frame Relay services with an ADTRAN ISDL OCU-R. This allows pair savings over traditional DDS deployment on local loops up to 18 kft of mixed gauge wire. The ISDL OCU-R is used to terminate the U-interface at the customer's premises provided by the U-BR1TE V and to convert the 2-wire ISDN signal to a 4-wire AMI DDS signal for presentation to the customer. Together, the U-BR1TE V and ISDL OCU-R allow testing over the ISDN transport network to be performed with traditional DDS methods. In this mode U-BR1TE Vs may be placed in tandem and function as DS0 DPs while the ISDL OCU-R functions as an OCU. See **Figure 7** for various U-BR1TE V DDS arrangements.

DDS Testing

For leased mode or DDS applications with the U-BR1TE V the D channel is typically disabled. Without the D channel, standard ISDN EOC loopbacks are unavailable to the ISDN transport system and testing may only be accomplished by using the in-band DDS loopback commands. The U-BR1TE V responds to latching loopback sequences for the DS0 DP. The U-BR1TE V allows the OCU loopback command to pass in-band downstream to the ISDL OCU-R.

Upon receipt of a DS0 DP latching loopback sequence the U-BR1TE V initiates a bilateral loopback for the B1 channel. This bilateral loopback allows testing of the 2B1Q local loop to the ISDL OCU-R simultaneously with network testing to the U-BR1TE V.

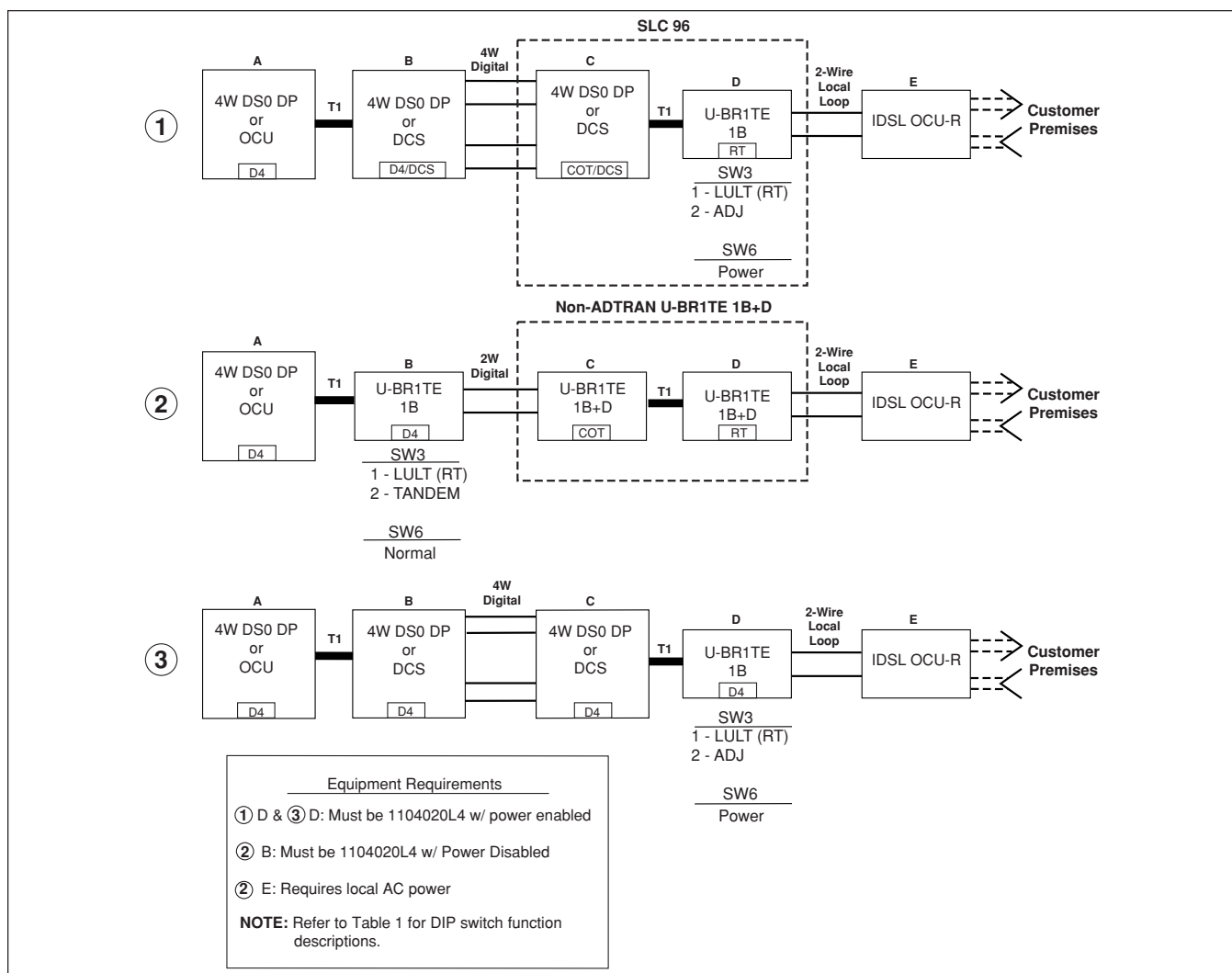

Figure 7. U-BR1TE V ISDL/DDS Circuit Diagram

DS0 DP Loopback EOC Remapping

Upon receipt of subsequent DS0 DP loopback codes when the D channel is disabled, the U-BR1TE V remaps the subsequent DS0 DP loopback sequences into the respective ISDN EOC loopback messages. This capability will permit all downstream ISDN D channel enabled U-BR1TEs, U-Repeaters, and TRISDN elements to respond to standard DDS DS0 DP loopback commands via the ISDN EOC as shown in **Figure 8**.

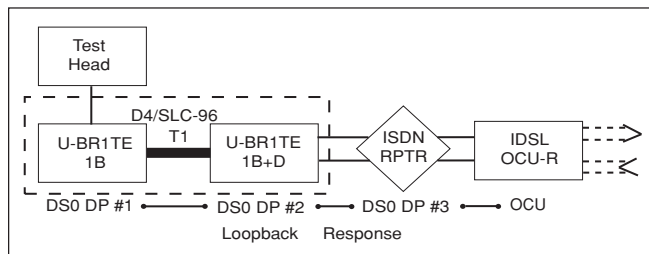

Figure 8. ISDL/DDS Loopback Response

NOTE

For DDS circuits with the D channel disabled, all tandem U-BR1TE elements should be ADTRAN U-BR1TE Vs with DDS Loopback Capability for remote end test operation to function properly. See 2B in Figure 7. In D channel disabled applications, older non-DDS vintage U-BR1TEs may not pass the OCU latching loopback sequence to the IDSL OCU-R.

Upon receipt of an OCU latching loopback sequence the U-BR1TE V passes the OCU sequence in-band downstream to the IDSL OCU-R. U-BR1TE Vs do not respond to the CSU latching loopback command but simultaneously pass it through to the CSU/DSU while mapping the NT1 EOC address. The IDSL OCU-R reverses sealing current on its 4-wire AMI DDS interface to place the customer CSU into loopback upon receipt of the CSU latching loopback.

The following data sequence enables the DS0 DP, OCU, and CSU latching loopbacks:

1. Minimum of 35 transition in progress (TIP) bytes (X0111010).
2. Minimum of 35 loopback select code (LSC) bytes: DS0 DP (X0000101), OCU (X1010101), CSU (X0110001).
3. Minimum of 100 loopback enable (LBE) bytes (X1010110).
4. Minimum of 32 far-end voice (FEV) bytes (X1011010).

X Denotes *Don't Care* bit - either a 1 or a 0.

If the U-interface of the U-BR1TE V is not in sync, the unit transmits MUX-Out-of-Sync (X0011010).

Disabling DS0 DP, OCU, or CSU latching loopback sequence:

1. Minimum of 35 TIP bytes.
or by pressing the front panel loopback button.

Front Panel Tests

The valid front panel tests in leased modes are ADR1, CRTX, LPTX, and LPBK for all circuit positions. NT1, ADR1-ADR6 loopback tests are valid for the LULT mode only. ADR2 would be used to test a U-Repeater or ADR2 and ADR3 would be used to test TRISDN elements respectively.

All active in-band loopbacks may be disabled by pressing the front panel loopback button once when a test set is not connected to the bantam jacks.

Initiate Loopback at IDSL OCU-R

When used for DDS, the D4 U-BR1TE may initiate a loopback at the IDSL OCU-R. The in-band latching OCU loopback code is sent to loop the IDSL OCU-R when the NT1 address is selected on SW2. To invoke the OCU loopback at the IDSL OCU-R, press the Test button with the front panel test knob in the NT1 address location.

Performance Monitoring

Local Performance Monitoring is available only for the U-interface, when configured for a leased mode of operation. See the subsections entitled *Loopback Tests*, *Point-to-Point Test*, and *Local Loopback* for applicable test descriptions.

ADTRAN U-BR1TE Bidirectional Loopback

In LULT Mode, the ADTRAN U-BR1TE will execute a bidirectional loopback when performing DS0 DP loopback. See **Figure 9** for an illustration of the bidirectional loopback.

Remote End Initiated LBK Tests

The U-BR1TE supports loopbacks generated from the remote unit which allows testing to be performed

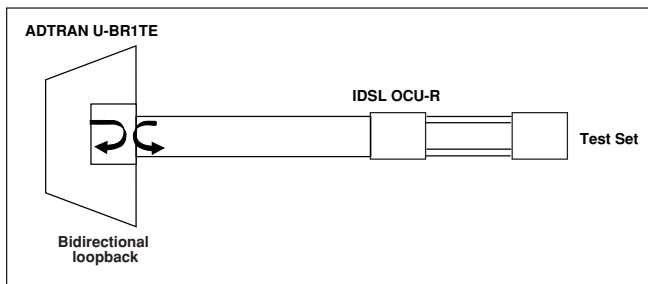

Figure 9. ADTRAN U-BR1TE Bidirectional Loopback

without coordination with the CO or test center. Loopbacks initiated by the OCU-R front panel LBK pushbutton aid in system turn up testing or troubleshooting from the remote end.

The U-BR1TE responds to a loopback command initiated at the OCU-R as follows:

Pressing the OCU-R LBK pushbutton on the OCU-R once will initiate a loopback at the U-BR1TE toward the customer. See **Figure 10**. This allows data to be sent from the remote end to test the local loop and the OCU-R. This loopback is indicated by a flashing CUST LBK LED on the IDSL OCU-R and a solid LBK LED on the U-BR1TE.

Pressing the OCU-R LBK pushbutton a second time will initiate a loopback at the OCU-R toward the 4-wire DDS (CPE) interface. A solid CUST LBK LED on the IDSL OCU-R indicates a loopback at the IDSL OCU-R toward the customer equipment. See **Figure 11**. Pressing the OCU-R LBK pushbutton a third time disables all current latching loopbacks initiated by the OCU-R LBK pushbutton.

If errors exist the loopbacks can help determine the source; either the local loop or the OCU-R.

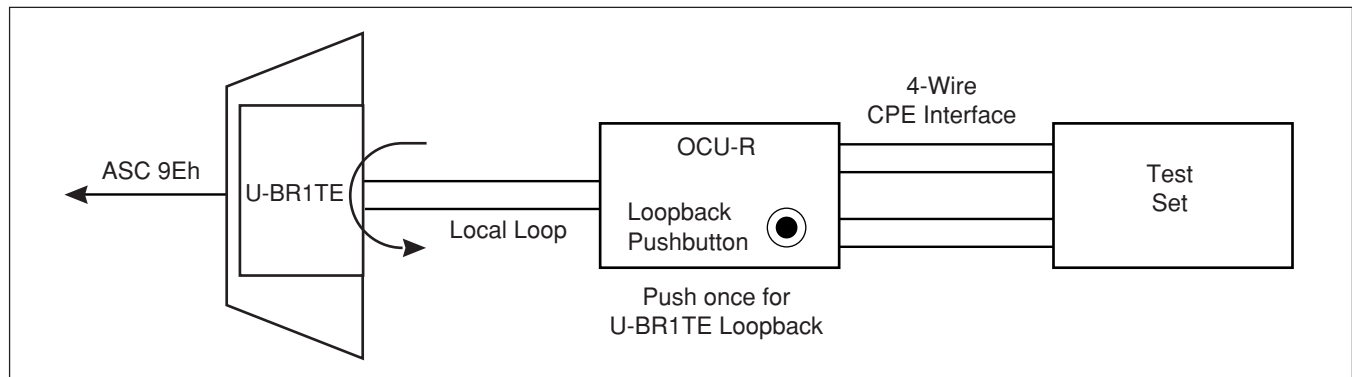

Figure 10. IDSL/DDS Remote End Initiated Loopback, Local Loop

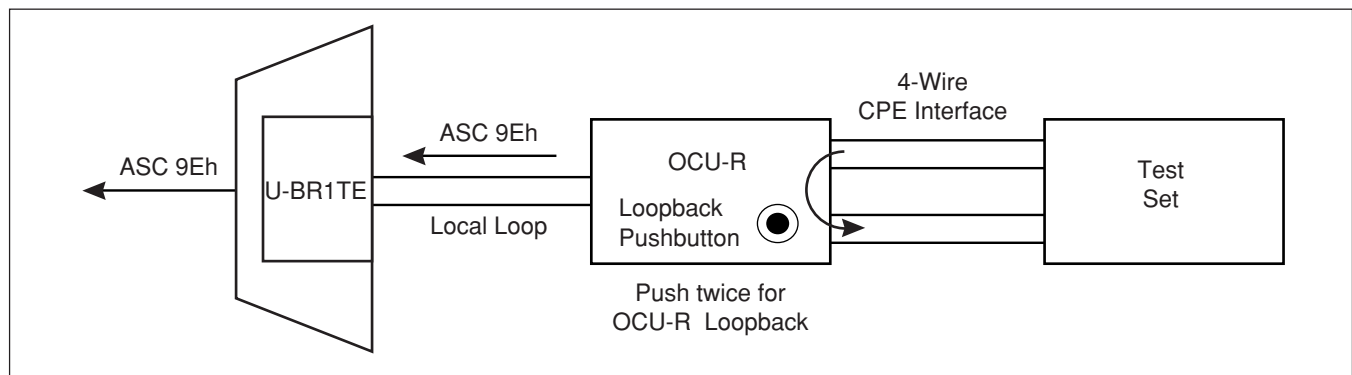

Figure 11. IDSL/DDS Remote End Initiated Loopback, Customer Loop

During a remote end initiated loopback the system transmits ASC 9Eh toward the network, indicating an out-of-service condition generated by the remote end, as shown in Figures 10 and 11.

All IDSL/DDS system latching loopbacks, whether initiated by the IDSL DCU-R craft interface, LBK pushbutton, CO, or from a remote Test Center, can be released by sending 35 DDS loop down TIP bytes <X0111010> (Where X is a “don’t care” bit). All existing latching loopbacks will also be disabled by pressing the LBK pushbutton on the CO or remote unit.

NOTE

The remote end test feature is only supported when the upstream U-BR1TE is an ADTRAN D4 or Series 5 U-BR1TE with DDS Loopback capability. Other U-BR1TEs will ignore the loopback command sent by pressing the IDSL OCU-R LBK button.

IDSL/DDS Trouble Code

The IDSL/DDS system provides a quick diagnosis in the case of a circuit condition where continuity is broken. The trouble code type received by a tester determines whether the open condition is occurring on the local loop or at the customer premises. In the event of a 2-wire DSL loss of signal, loss of sync, or open condition caused by an open conductor or disconnected 2-wire loop, the U-BR1TE V transmits a MUX-Out-of-Sync trouble code (MOS 9Ah) into the network as shown in **Figure 12**. During a similar out-of-service condition at the customer premises, the IDSL OCU-R transmits Abnormal Station Code (ASC 9Eh) upstream toward the network as shown in Figure 12.

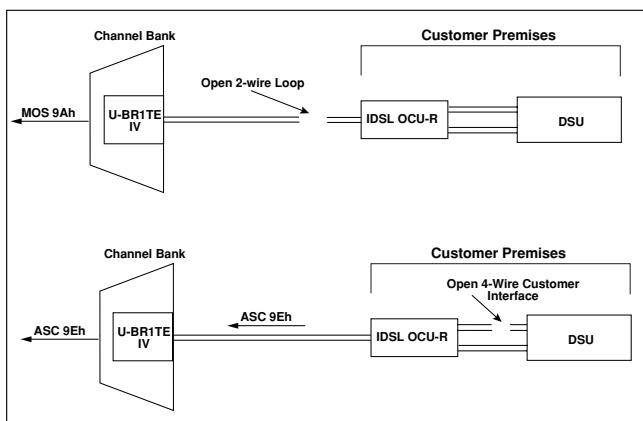

Figure 12. IDSL/DDS Trouble Codes

2B Leased Mode Operation

The U-BR1TE V is deployed in 2B leased line operation to provide DDS/Frame Relay services to ISDN equipment. By using the 2-wire ISDN interface for 128 kbps data rate, the U-BR1TE V Leased Mode Operation allows pair savings over traditional DDS deployment. DDS/Frame Relay support allows loopback testing to be performed across the ISDN transport system in this configuration.

The U-BR1TE V will decode DDS latching loopback sequences coming from the carrier into *eoc* loopback commands usable by traditional ISDN equipment. See **Figure 13** for various U-BR1TE V DDS 2B Leased Mode arrangements. In a SLC-96 network the U-BR1TE V units will operate in both 2B+D or 2B mode. Both units must be in the same mode.

Loopback Operation

To enable detection of DDS latching loopbacks, the ADTRAN U-BR1TE V must be provisioned as an LT- like device in leased 128 kbps (2B) mode of operation.

When B1 and B2 are enabled, data on both channels are looped in response to a DDS latching loopback sequence detected on channel B1. The U-BR1TE V will respond to a DS0 latching loopback intended for DS0 #1. Loopback commands intended for DS0 #2 and greater are re-mapped to ISDN *eoc* loopback commands addressed to the appropriate unit.

The U-BR1TE V will map a CSU latching loopback sequence to an ISDN *eoc* NT1 loopback. Figure 13 shows the DDS latching loopback commands that will loop each unit.

NOTE

Only the B1 channel will detect the DDS loopback sequences for activation and deactivation of DS0 and CSU latching loopbacks. All standard U-BR1TE units between the ADTRAN U-BR1TE V and the NT1 device must have the D-channel enabled in order for loopbacks to be processed beyond the U-BR1TE V.

4. MAINTENANCE

The ADTRAN U-BR1TE V does not require routine maintenance for normal operation.

5. WARRANTY AND CUSTOMER SERVICE

ADTRAN will replace or repair this product within ten (10) years from the date of shipment if it does not meet its published specifications or fails while in service. Refer to ADTRAN *U.S. and Canada Carrier Networks Equipment Warranty*, document 60000087-10.

Contact Customer and Product Service (CAPS) prior to returning equipment to ADTRAN.

For service, CAPS requests, or further information, contact one of the following numbers:

ADTRAN Sales

Pricing/Availability
(800) 827-0807

ADTRAN Technical Support

Pre-sales Applications/Post-sales Technical Assistance
(800) 726-8663

Standard hours: Monday-Friday, 7 a.m. - 7 p.m. CST
Emergency hours: 7 days/week, 24 hours/day

ADTRAN Repair/CAPS

Return for Repair/Upgrade
(256) 963-8722

Repair and Return Address

ADTRAN, Inc.
CAPS Department
901 Explorer Boulevard
Huntsville, Alabama 35806-2807

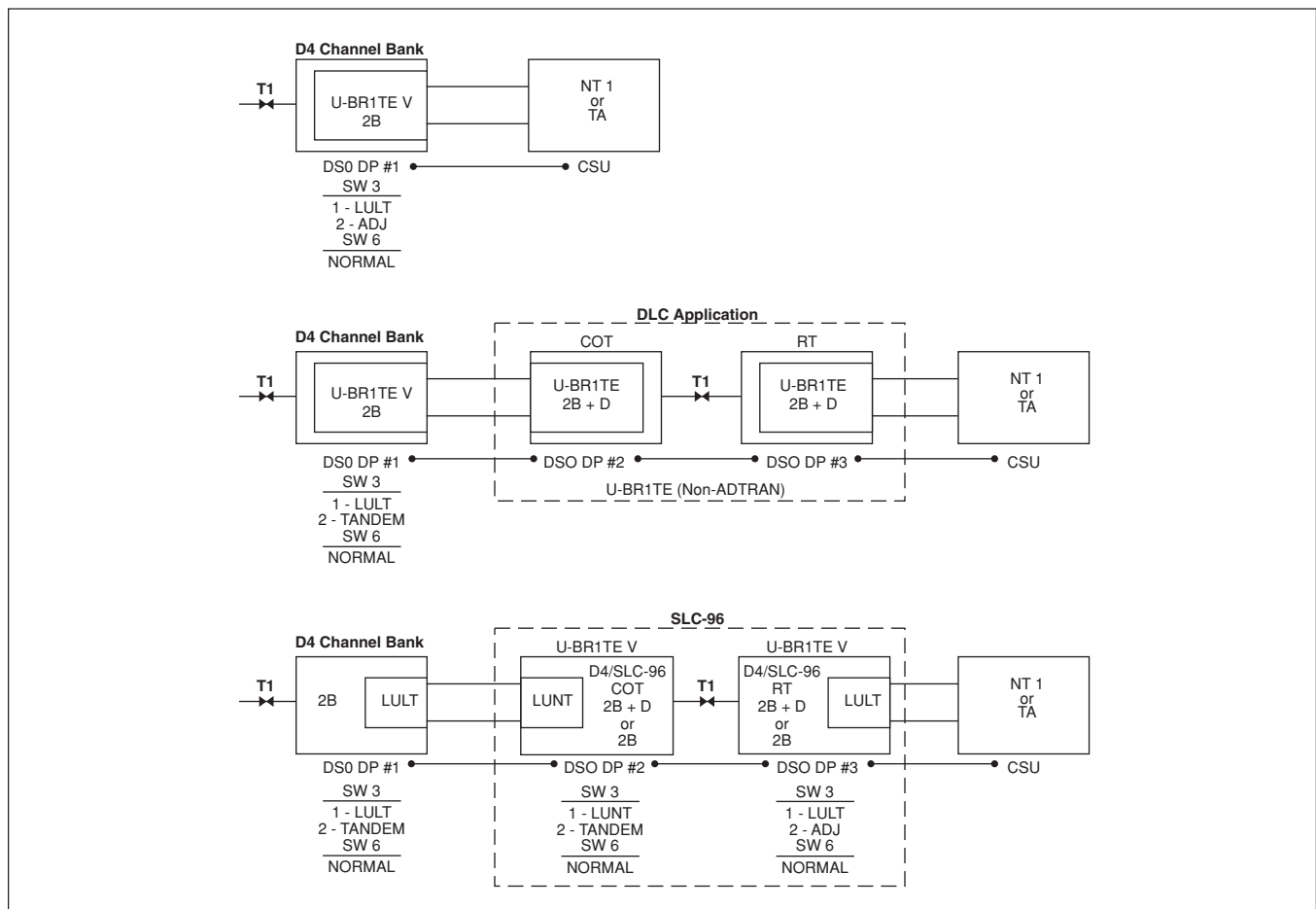

Figure 13. DS0 Latching Loopback

Free Manuals Download Website

<http://myh66.com>

<http://usermanuals.us>

<http://www.somanuals.com>

<http://www.4manuals.cc>

<http://www.manual-lib.com>

<http://www.404manual.com>

<http://www.luxmanual.com>

<http://aubethermostatmanual.com>

Golf course search by state

<http://golfingnear.com>

Email search by domain

<http://emailbydomain.com>

Auto manuals search

<http://auto.somanuals.com>

TV manuals search

<http://tv.somanuals.com>