

QSP-660

Owner's Manual

and

Operating Instructions

Instructions for basic operation and installation

P/N 000-0865-002



Advanced Technology Video, Inc.

14842 NE 95th Street · Redmond, Washington 98052

Phone 888/288-7644 · 425/885-7000 · Fax 425/881-7014

Customer Service: sales@atvideo.com

Technical Service: tech@atvideo.com

Home Page: <http://www.atvideo.com>

Table of Contents

Introduction	3
Operational Features Description	3
Live Camera Displays	3
DigiLock™ and Playback	3
VCR Bypass.....	3
Advanced Alarm System with Alarm Scheduling.....	3
Alarm Log and Printing.....	3
Getting Started.....	4
Installation Steps.....	4
Back Panel Connections.....	5
Video Line Termination Switches.....	5
Operation	6
Remote Control Operation	7
Set Up Menus	8
Main Menu.....	8
Set Time/Date.....	8
Other Display Options.....	9
Advanced Function Menus	9
Camera Set Up.....	9
Camera Label Changing.....	9
Sequence Set Up.....	10
Sequencing Format Screens	11
Alarm Set Up	12
External Alarms	12
Video Loss Alarms.....	12
Alarm Scheduling.....	13
Set Alarm Enable Schedule	13
Enable Scheduled Alarms.....	13
Alarm Control Options	14
Alarm Dwell Adjustment.....	14
Alarm Activation Type.....	15
Alarm Log	15
Other Options	16
Security Set Up.....	16
Hand Held IR Remote Control	17
Programming your ATV QSP-660 Remote Control	17
Alarm Interconnection on the QSP-660	18
RS-232 Remote Control Interface.....	20
Equipment Requirements	21
Specifications.....	21
Warranty Information	22
YEAR 2000 CONFORMANCE	22
LIMITATION OF WARRANTY	22
FCC Statement	22

INTRODUCTION

Thank you for purchasing Advanced Technology Video's QSP-660 four camera Real Time Quad. This instruction manual describes the powerful features of this product for basic and advanced operation. It also covers the installation steps that will allow quick and easy integration into your security system.

The following section provides an overview of the operational features of the QSP-660. If you are familiar with the QSP-660, you should proceed to the **Getting Started** section on page 4 for step-by-step installation instructions.

OPERATIONAL FEATURES DESCRIPTION

Live Camera Displays

The QSP-660 is initially in the Live Camera Display mode whenever power is applied to the unit. Live cameras can be displayed in quad, PIP, dual PIP, split screen, squish screen, or full frame formats. In addition, any display can be frozen using a front panel button, the IR remote control, or external signal input. In any of these display modes, the unit can be programmed to sequence one or more cameras with a programmable dwell time.

DigiLock™ and Playback

In VCR playback mode, digital information is used to compensate for the poor vertical synchronization signals frequently encountered with time lapse VCRs.

The QSP-660 DigiLock™ decoding reconstructs the timing so that successfully decoded frames are read into monitor display memory consistently without any jumping, tearing, or other side-effects of poor synchronization.

VCR Bypass

Many VCRs have on-screen programming menus that require a monitor for programming the VCR. The QSP-660 includes a VCR Bypass feature that facilitates VCR programming by allowing the QSP-660 VCR input (VCR's video output) to be routed directly to the display monitor.

Advanced Alarm System with Alarm Scheduling

The QSP-660 contains the most advanced and flexible Alarm System available in a video real time quad. The QSP-660 Advanced Alarm System supports External Alarms and Video Loss Alarms. In addition, the QSP-660 alarm system can be enabled and disabled through a 7-day Alarm Schedule and/or a user programmable external Master Enable signal.

The QSP-660 has four alarm channels associated with the four camera inputs. Each alarm channel includes a programmable external alarm and Video Loss Alarm. External alarm inputs are individually selectable for contact closure or opening as well as logic levels (+5V, 0V). Each alarm channel may also be individually selected for enable/disable through the QSP-660 Alarm Schedule. The Alarm Schedule is a 7-day timer schedule with a single ON and OFF time associated with each day of the week. The QSP-660 also has an external input signal that can be selected between picture Freeze and Alarm Master Enable. The Alarm Master Enable signal can be used in conjunction with your burglar alarm control panel so that the alarm control panel can enable or disable the QSP-660 alarm system. For more information on "Alarm Scheduling" see page 13.

Alarm Log and Printing

The QSP-660 has an internal Alarm Log that provides storage for up to 100 alarm events. In addition, its text can be transmitted to the serial port for printing or storage on a host computer. The Alarm Log is a circular storage buffer so that the most recent alarm events are always stored. Alarm event text can also be sent directly to the serial port, when an event occurs, for immediate printing or external processing. Alarm events, which may be printed and stored in the Alarm Log, include any enabled External Alarms or Video Loss Alarms. For instructions on the use of the QSP-660 alarm log and printing features see "Alarm Log" on page 15.

GETTING STARTED

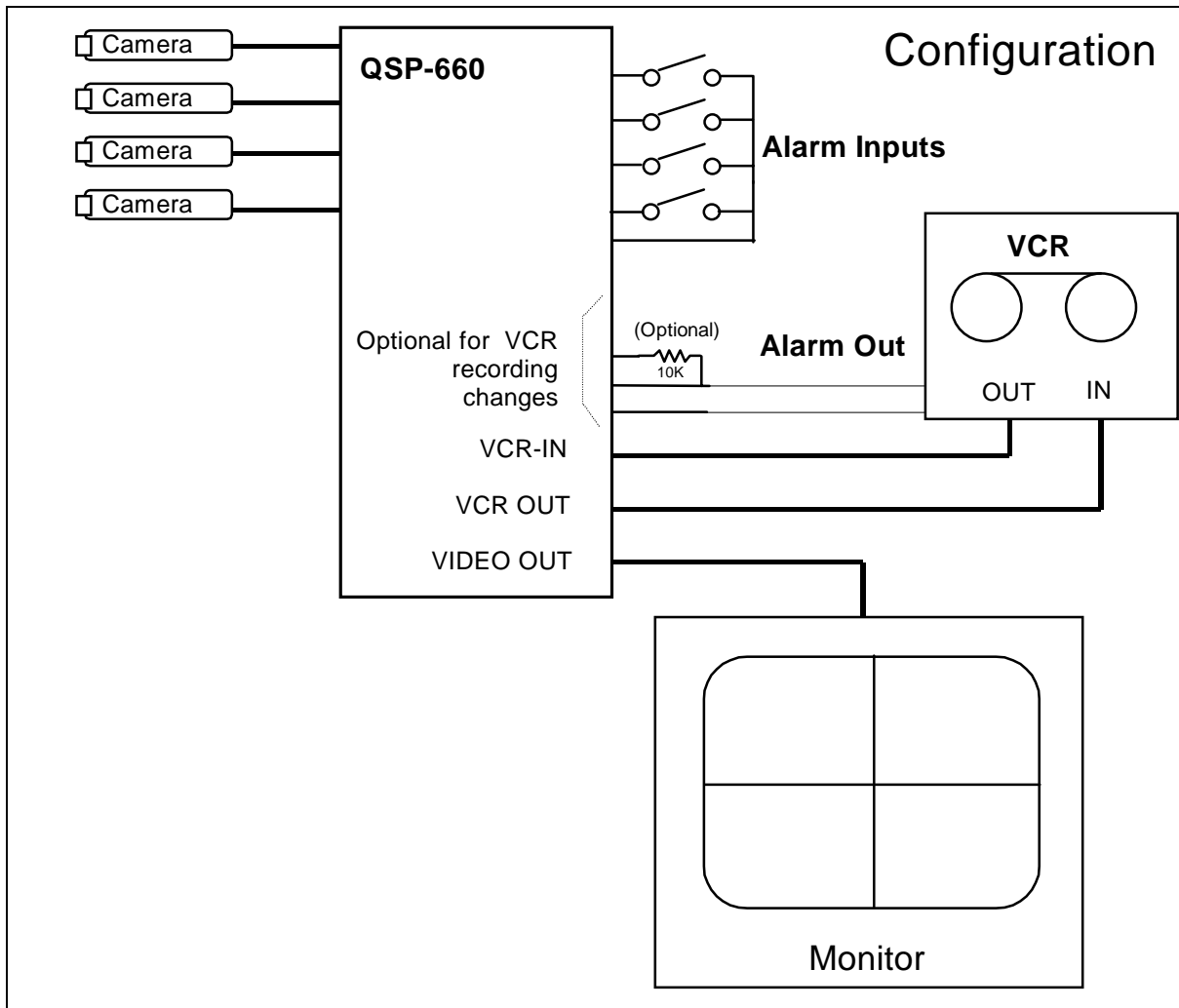

The above diagram shows the typical 4-camera installation for the QSP-660. Up to four cameras can be connected to the real time quad using the back panel connectors.

Note: The VCR and monitor connections must be as shown above for proper operation.

Installation Steps

The following steps should be followed to ensure proper connection and set up of your QSP-660. A diagram showing the overall connection configuration of the QSP-660 is shown above. The installation steps are:

1. Connect your cameras, monitor, and VCR (if recording is necessary) to the QSP-660. Refer to the "Back Panel Connections" and "Video Line Termination Switches" section on page 5 for proper connections and switch settings for your particular installation.
2. Power up the QSP-660, then enter the QSP-660 set up menus by pressing and holding the **DISPLAY** button for approximately 3 seconds. Refer to the **Set Up** menu section of the manual starting on page 8. Set the current time and date in the QSP-660 using the **Set Time/Date** menu.
3. Exit the QSP-660 menus by pressing the **DISPLAY** button to exit each menu and finally the menu system.

4. If your VCR has internal on-screen menus for its set up, use the **VCR Bypass** feature of the QSP-660 to view the VCR's on-screen menus on the display monitor. See the "VCR Bypass Function" description on page 3.
5. At this point, the basic configuration of your QSP-660 is complete. You may now proceed to set more advanced functions as required for your installation (alarms, camera labels, etc.) Refer to the **Advanced Function menus** starting on page 9 for detailed information.

BACK PANEL CONNECTIONS

The four-camera input BNC connectors are labeled LOOP and the factory default configuration is 75 ohm termination ON. One DIP switch and three jumpers inside the unit (see section below) determine whether each inputs' 75 ohm termination is ON or OFF.

Connect the QSP-660 VCR IN to the video output of the VCR and the QSP-660 VCR OUT to the video input of the VCR. The alarm connector is a standard DB-15, which will mate with the included alarm wire adapter board or standard computer-type cable. See page 18 for further alarm connection information.

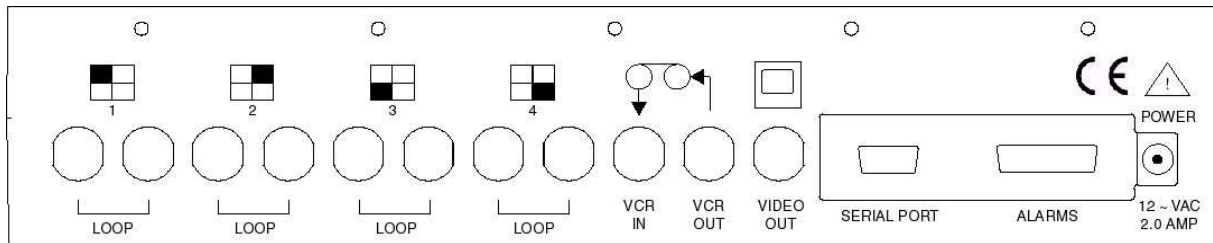

VIDEO LINE TERMINATION SWITCHES

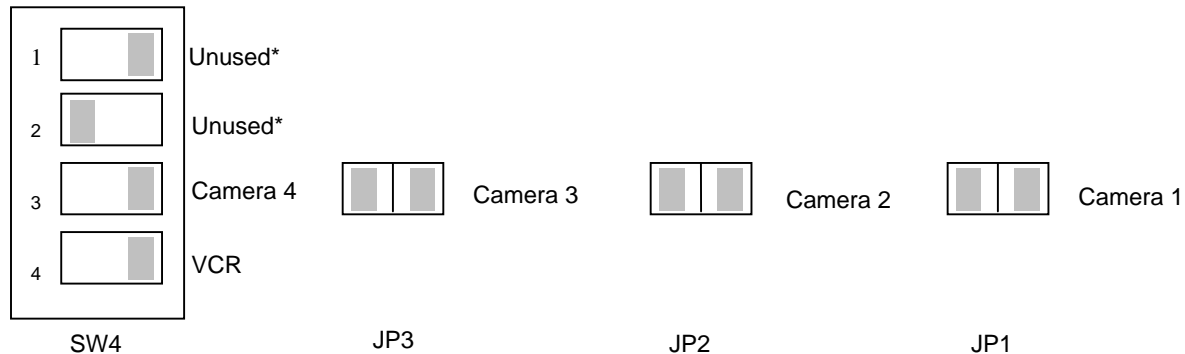

**This switch must be in the position shown for proper QSP-660 operation.*

The video line termination switches/jumpers for each camera input are located in the rear of the unit and are accessed by removing the top cover. The switches/jumpers are in the order shown above when looking down on the circuit board. The above switches/jumpers are shown in the factory default settings (75 ohm terminations ON).

Note: There is an additional termination switch for the VCR input on position 4 of SW 4.

OPERATION

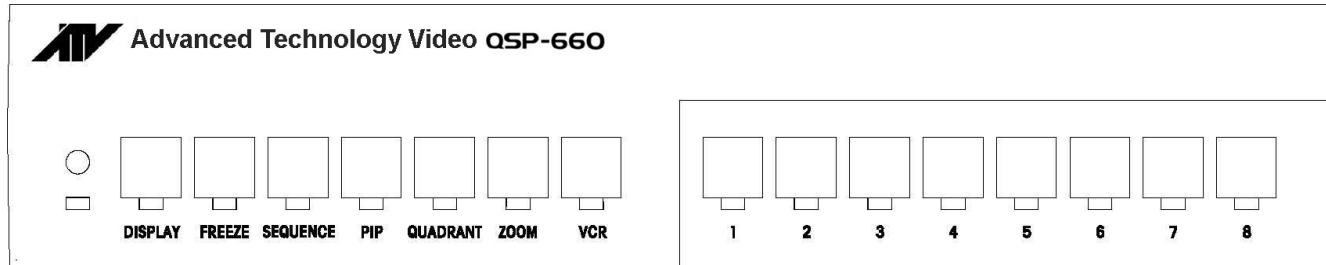

Your QSP-660 has seven mode control buttons and four numbered camera buttons which allow easy access to all modes of operation. The seven mode buttons on the left are used to control monitor display operations and VCR playback. An LED below each button will light when the unit is in the mode corresponding to that button.

***Note:** Live camera display modes **will** affect recording. Following is a summary of each button's function and the QSP-660 operating modes.*

DISPLAY

During live mode, this button selects the quad display. It will also return the unit to the quad display mode from any other (non-quad) display mode. A push and hold of this button for approximately 3 seconds will bring up the QSP-660 set up main menu.

FREEZE

In all display modes a press of this button will freeze the camera image(s) on the monitor display (the output to the VCR recording is also frozen in this case). Another push of this button will deactivate the freeze mode.

SEQUENCE

A button press will activate the camera sequencing for the live mode. Another push of this button will deactivate the sequencing mode. The default camera hold time is 3 seconds.

PIP

When starting in the quad or full screen camera display in live display mode, pressing the **PIP** (Picture-in-Picture) button will cause the unit to switch to the Single PIP display. Additional presses will cycle the unit through Dual PIP, Split Screen, Squish Screen, Full Frame and back to Single PIP displays.

QUADRANT

This button rotates the orientation of the cameras clockwise on the screen into the desired positions in PIP, Dual PIP, Split Screen, and Squish Screen display modes.

ZOOM

The ZOOM function will expand a quadrant of any image in playback mode. Repeated presses of this button will rotate through the quadrants.

VCR

Pressing this button will switch monitor display from the live camera display mode to the VCR playback mode. The LED indicator will light to show that VCR playback is now possible.

VCR Bypass Function.

The VCR Bypass function is activated by a long button press of the **VCR** button for approximately 3 seconds. While in VCR Bypass mode, the QSP-660 will pass the VCR output directly to the monitor. A single push of the **VCR** button will return the unit to normal VCR playback mode and a second push will return the unit to live display mode.

CAMERA Buttons (1 Through 4)

The individual camera buttons **1** through **4** are used to select which camera is to be used for display purposes during live display modes and as zoom in playback. In addition, camera buttons **1** through **4** are also used in the QSP-660 set up menus.

REMOTE CONTROL OPERATION

The IR remote control provided with your QSP-660 has a limited set of buttons. Operation with the remote control is slightly different than the front panel. The remote control has a single CAMERA button for selecting cameras and successive button presses will rotate through the available cameras. Sequencing is initiated by pressing and holding the remote control's FREEZE button for approximately 3 seconds. Pressing the QUADRANT button anytime in VCR playback accesses the ZOOM function.

Note: *Menus are not available through the remote control. The remote control must be programmed when the batteries are removed. See "Programming Your ATV QSP-660 Remote Control" on page 17.*

SET UP MENUS

The QSP-660 set up is accomplished through its on-screen menus. To enter the menu system, push and hold the **DISPLAY** button for approximately 3 seconds. The display will then show the top-level menu. Selection of any menu item is done with the camera buttons. Selecting **DISPLAY** will exit the present menu level.

Main Menu

Selecting:

1. Enters Set Time/Date menu to program the internal clock and select time and date display options.
2. Enters Camera Set Up menu to program camera labels.
3. Enters Display Sequence Set Up menu to set sequence cameras to be displayed.
4. Enters Alarm Set Up menu to enable/disable alarms and program alarm action.
5. (Press **VCR+1**) Enters the Other Options menu where you can select remote control code, program a security code for locking out the menus and the front panel buttons, or reset unit to factory defaults.
6. (Press **VCR+2**) Selects the language used for QSP-660 menus and messages.

Advanced Technology Video
QSP660 V3.200

1: Set Time/Date . . .
2: Camera Set Up . . .
3: Sequence Set Up . . .
4: Alarm Set Up . . .
5: Other Options . . .
6: Language

Camera: Select
5 is VCR + 1
6 is VCR + 2

DISPLAY: Exit Menu System

Set Time/Date

Time and date for the on-screen calendar and clock is set from this menu.

Selecting:

1. Edits the hour of the day. In 24-hour mode, 0 through 23 are accepted as entered.
2. Edits the minutes field. Only values 0 through 59 are accepted.
3. Edits the seconds field. Only values 0 through 59 are accepted.
4. Edits the day of the month. Only valid values for the month selected will be accepted.
5. (Press **VCR+1**) Advances the month with each press.
6. (Press **VCR+2**) Edits the year.
7. (Press **VCR+3**) Edits the day of the week.
8. (Press **VCR+4**) Toggles the format between 24-hour AM / PM.
9. (Press **QUADRANT**) Enters the Other Display Options menu to turn the Time/Date display on or off, or to change the position of the display on the screen.

Set Time/Date

12:03:28 23 MAR 98 MON

1: Edit Hours 4: Edit Day
2: Edit Minutes 5: Edit Month
3: Edit Seconds 6: Edit Year
7: Edit Day of Week
8: Time format AM/PM/24hr
9: Other Display Options

Camera: Select
5 is VCR + 1
6 is VCR + 2
7 is VCR + 3
8 is VCR + 4
9 is QUADRANT
0 is PIP

DISPLAY: Accept and Return

The times shown in this menu come directly from the internal clock. Actual time is constantly changing while new values are entered. All the values shown on the screen are updated any time one of them is entered. To accurately set the clock to the desired time, edit the SECONDS entry last. The current time and date are preserved if a new entry is not accepted or completed.

Other Display Options

This menu determines the display behavior of the date and time information for both the VCR and monitor camera displays.

Selecting:

1. Toggles the time and date display location through any one of the four display quadrants for live camera displays.
2. Toggles the time and date for the monitor display On/Off.

Other Display Options

1: Location Lower Right
 2: Display On

Camera: Select
 DISPLAY: Accept and Return

ADVANCED FUNCTION MENUS

This section describes the use of the advanced functions of the QSP-660. The following features allow you to customize the operation of your QSP-660 as necessary to complete your installation.

Camera Set Up

This menu determines the display behavior of the camera labels and allows access to menus for entering/changing labels.

Selecting:

1. Toggles the camera labels On/Off for the monitor display.
2. Enters Camera Labels menu to review, enter, or change camera labels.

Camera Set Up

1: Labels on Display: On
 2: Change Labels . . .

PIP: Restore Default Settings
 Camera: Select
 DISPLAY: Accept and Return

Camera Label Changing

This menu is used for adding/changing labels that are associated with each of the four cameras.

Selecting:

- 1 - 4** Selects the camera for editing and exposes the legend at the right hand side of the screen. After pressing a camera button **1** through **4**, the display will appear as shown.

Using the legend, any character can be entered in the present character location. The **SEQUENCE** button is used to move to the next location.

Camera Labels	Characters
1. ■	PIP: Space 0
2. 2	1: ABC1
3. 3	2: DEF2
4. 4	3: GHI3
	4: JKL4
	5: MNO5
	6: PQR6
	7: STU7
	8: VWX8
	9: YZ9
5 is VCR + 1 6 is VCR + 2 7 is VCR + 3 8 is VCR + 4 9 is QUADRANT	
SEQUENCE: Next Character DISPLAY: Accept Label	

Sequence Set Up

A unique feature of the QSP-660 is the option to customize the display sequence format to suit your application. You can program a specific selection of cameras for sequencing.

Selecting:

1. Enters edit mode for hold (dwell) time.

While editing:

- 1 - 4** Used to enter digits 1 through 4
- 5 - 6** VCR + 1-2
- DISPLAY** Completes the entry if less than three digits and returns to the previous value if no digits are entered.

2. Enters Full Camera Display Sequence format menu.
3. Enters Quad Display Sequence menu.
4. Enters PIP Display Sequence menu.
5. Enters Dual PIP Display Sequence menu.
6. Enters Split/Squish Display Sequence format menu.

Note: Any changed camera display sequence will not be applied until the display sequencing mode is activated by the front panel button.

Display Sequence Set Up	
1:	Hold Each Image for: 3 Sec.
2:	Full Camera Call Up . . .
3:	Quad . . .
4:	PIP . . .
5:	Dual PIP . . .
6:	Split/Squish
PIP: Restore Default Settings	
Camera: Select	
5 is	VCR + 1
6 is	VCR + 2
DISPLAY: Accept and Return	

Sequencing Format Screens

Full Camera Display Sequence

1: Cameras: 1 2 3 4

Enter Cameras you want displayed in the sequence

Camera: Select
DISPLAY: Accept and Return

Quad Display Sequence

1: Upper Left: 1 . . .
2: Upper Right: . 2 . .
3: Lower Left: . . 3 .
4: Lower Right: . . . 4

Enter Cameras you want displayed in the sequence

Camera: Select
DISPLAY: Accept and Return

PIP Display Sequence

1: Background: As is
2: Insert: 1 2 3 4

Enter Cameras you want displayed in the sequence

Camera: Select
DISPLAY: Accept and Return

Dual PIP Display Sequence

1: Background: As is
2: Insert 1: 1 2 3 4
3: Insert 2: As is

Enter Cameras you want displayed in the sequence

Camera: Select
DISPLAY: Accept and Return

Split/Squish Display Sequence

1: Left: As is
2: Right: 1 2 3 4

Enter Cameras you want displayed in the sequence

Camera: Select
DISPLAY: Accept and Return

The above screens show the factory default values. The most commonly used sequencing is the full frame or quad formats as shown above. You can customize any or all formats, and may have more than one section of a multi-camera display defined for sequencing. For any particular camera display, cameras are sequenced in ascending numerical order and cameras cannot be repeated. For example, if the pattern "1,3,4,2,1,3" were entered, the software will translate this to ". 2 . 4 "

Alarm Set Up

Selecting:

1. Enters individual cameras for External Alarms menu.
2. Enters individual camera Video Loss Alarms.
3. Enters Set Alarm Enable Schedule menu.
4. Enters Enable Scheduled Alarms menu.
5. (Press **VCR+1**) Enters Alarm Control Options menu.
6. (Press **VCR+2**) Enters Alarm Log menu.
7. (Press **VCR+3**) Toggles Serial Alarm Output between On and Off. (The factory default is "Off"). When Serial Alarm Output is On, alarm event text will be sent directly to the serial port (printer) as well as the Alarm Log. The Serial Alarm Output does not need to be On in order to output (print) the Alarm Log.

External Alarms

Selecting:

- 1 - 4** Toggles external alarms ON/OFF.

When an alarm event occurs on the camera alarm enabled with this menu, an alarm output will be generated if the alarming camera input is enabled through the Enable Scheduled Alarms menu (See Alarm Scheduling on the page 13). If the event is allowed to occur, the alarming camera(s) will be displayed. When an alarm is disabled (Off), an alarm input will not affect any aspect of the VCR or the live camera display. Alarms that are turned off will not generate an alarm output.

Video Loss Alarms

Selecting:

- 1 - 4** Toggles the selected camera Video Loss alarm between On and Off. (The factory default is "Off").

An alarm will be generated upon loss of video input on any camera with the Video Loss Alarm enabled, provided the camera's alarming input is enabled through the Enable Scheduled Alarms menu. The **No Video** message will be displayed anytime a camera video input is not present, regardless of the alarm settings.

Alarm Set Up	
1:	External Alarms . . .
2:	Video Loss Alarms . . .
3:	Set Alarm Enable Schedule . . .
4:	Enable Scheduled Alarms . . .
5:	Alarm Control Options . . .
6:	Alarm Log . . .
7:	Serial Alarm Output: Off
PIP: Restore Default Settings	
Camera: Select	
5 is VCR + 1	
6 is VCR + 2	
7 is VCR + 3	
DISPLAY: Accept and Return	

External Alarms	
1:	On
2:	On
3:	On
4:	On
Camera: Select	
DISPLAY: Accept and Return	

Video Loss Alarms	
1:	Off
2:	Off
3:	Off
4:	Off
Camera: Select	
DISPLAY: Accept and Return	

Alarm Scheduling

The QSP-660 contains a very flexible and advanced alarming system designed to provide an optimum solution for any installation. Along with the ability to enable various types of alarm inputs, a built in 7-day timer may also be used to individually enable and disable each alarm. The following menus are used to set the timer and select which alarms the timer will control.

Set Alarm Enable Schedule

Selecting:

- 1 - 7** Selects one of the days of the week to modify on and off times.
- 8** Copies the on and off times of Monday to all the other weekdays (Tuesday – Friday).
- 9** (Press **QUADRANT**.) Copies the On and Off times of Saturday to Sunday.

When a day of the week is selected for scheduling (1-7), the display will change to reflect the time you are editing and additional button functions will be displayed. When editing times for a selected day, the **FREEZE** button will set the alarm system to be On All Day. Similarly, the **ZOOM** button will set the alarm system to be Off All Day. When editing a time field, camera buttons are used to enter digits 1 through 4 (5-8 are entered as VCR +1-4), the **QUADRANT** button is used to enter 9, and the **PIP** button is used to enter 0. The **SEQUENCE** button will move to the next editable field up through the last editable field where it will accept the line and return the display to the non-edit mode as shown. The **DISPLAY** button will accept the current entry and move to the next editable field up through the last editable field where it will accept the line and return the display to the non-edit mode as shown.

Note: The setting of the hours format in the Set Time/Date menu will determine the hours display in this menu. Also, note that when the system is in 12-hour time mode, the AM/PM field must also be edited. The factory default times for each day of the week are on at 18:00 (6:00PM) and off at 06:00 (6:00AM).

Enable Scheduled Alarms

Selecting:

- 1 - 4** Toggles the selected camera alarm enable between Normal and Schedule. (The factory default is "Normal").

When Normal enable mode is selected, camera alarm event types selected through the **Alarm Control Options menu** (see page 14) and will generate an alarm. Similarly, when Scheduled enable mode is selected, the same camera alarm event will only generate an alarm if the current time and day of the week fall within the On and Off times specified in the **Set Alarm Enable Schedule menu** (see above). Camera alarm events occurring outside of the On and Off times specified will be ignored when "Schedule" enable mode is selected.

Set Alarm Enable Schedule		
	On Time	Off Time
1: Monday	18:00	06:00
2: Tuesday	18:00	06:00
3: Wednesday	18:00	06:00
4: Thursday	18:00	06:00
5: Friday	18:00	06:00
6: Saturday	18:00	06:00
7: Sunday	18:00	06:00
8: Copy Monday to Tuesday – Friday		
9: Copy Saturday to Sunday		
Camera: Select		
5 is VCR + 1		
6 is VCR + 2		
7 is VCR + 3		
8 is VCR + 4		
9 is QUADRANT		
DISPLAY: Accept and Return		

Enable Scheduled Alarms	
1: Normal	
2: Normal	
3: Normal	
4: Normal	
Camera: Select	
DISPLAY: Accept and Return	

Alarm Control Options

Selecting:

1. Enters the Set Alarm Hold Times menu.
2. Enters the Set Alarm Activation Type menu.
3. Toggles the External Control Input between Picture Freeze and alarm Master Enable. (The factory default is "Picture Freeze".)
4. Toggles the alarm Master Enable Input Type between Logic Low and Logic High. (The factory default is "Logic Low")

When the External Control Input is selected to be picture Freeze, a single pulse on the input will freeze the current picture on the main display. Another single pulse will return the display to its normal updating mode. When Master Enable is selected as the external control input, the entire QSP-660 alarm system will be enabled or disabled by this input according to the logic level specified by the Master Enable Input Type setting. This input can be used to control the QSP-660 alarm system from a burglar alarm system, or other external control system.

Alarm Dwell Adjustment

Selecting:

1. Allows changing the alarm ACTIVATION HOLD time.
2. Allows setting of a MAXIMUM time for an alarm to be displayed.
3. Allows changing the monitor alarm display SEQUENCE DWELL time.

Some alarming devices (such as some motion detectors) generate very brief alarms lasting only a fraction of a second. The **Hold Detected Alarms** time is the amount of time that the alarm event will be held so that the alarm camera image can be kept on the display screen and to the VCR.

The maximum time for holding an alarm display set in the **Disable Detected Alarms** option will determine how long a continuous alarm camera will be displayed. This can be adjusted so that a continuous alarm will not consume all of the VCR's record time. A value of zero will result in no time limit for an alarm display. (The factory default is "0").

The **Hold Alarmed Images** time determines the image display hold time during multi-camera alarms. When multiple alarms occur simultaneously, the monitor display will sequence between all cameras with alarms using this dwell time.

Both delay times are adjustable from 1 to 255 seconds. The default is 1 second for the activation hold and 3 seconds for the sequence dwell time. **Camera buttons** are used to enter digits 1 through 4 (5-8 is VCR +1-4) the **QUADRANT** button is used to enter digit 9, and the **PIP** button is used to enter 0. The **DISPLAY** button stops the editing of a delay value.

Alarm Control Options

1: Set Alarm Hold Times . . .

2: Set Alarm Activation Type . . .

3: External Control Input: Freeze

4: Master Enable Input Type:
Logic Low

Camera: Select
DISPLAY: Accept and Return

Set Alarm Hold Times

1: Hold Detected Alarms
for: 1 Sec.

2: Disable Detected Alarms
after: 0 Sec.

3: Hold Alarmed Images
for: 3 Sec.

Camera: Select
DISPLAY: Accept and Return

Alarm Activation Type

Selecting:

- 1 - 4** Toggles individual camera alarm types between Contact Closure, Contact Open, Logic Low, or Logic High, triggering the alarm.

In many applications the switch contact connection is between the alarm input pin and the chassis or signal ground. In the QSP-660 the contact connection can be between either the ground (alarm connector pin 15) or the +5V (alarm connector pin 13). In some alarming devices this is not a metallic switch contact but rather a solid state device that grounds (Logic Low) the input as a normal condition or as an alarm condition. The four activation modes are provided to simplify connection to most alarm sources. (The factory default Alarm Activation Type is "Contact Closure").

The QSP-660 alarm activation is defined as follows:

- Contact Closure: The alarm pin is connected to a current source (either +5V or ground).
 Contact Open: The alarm pin is not connected to any current source (unconnected pin).
 Logic Low: A logic "low" level less than 0.8V (ground) is present at the alarm pin.
 Logic High: A logic "high" level greater than 2.4V (+5V) is present at the alarm pin.

Alarm Log

The Alarm Log menu is used to view the current contents of the internal Alarm Log and to clear the log or transmit the log contents to the serial port for printing. The Alarm Log contains the time, date, camera number, and type of alarm for each alarm event that has been stored. It can store up to 100 alarm events at which point new alarm events continue to be stored and replace the oldest event in the buffer. An Overflow message is displayed in the upper left corner of the Alarm Log menu if more than 100 events have occurred indicating older alarm events have been displaced. An alarm event is generated when any enabled and valid scheduled External or Video Loss alarm occurs. For more information see **Alarm Scheduling** on page 13. The Alarm Log is a very useful tool for reviewing the VCR recording allowing rapid location and review of recorded video time periods of interest.

The Alarm Log may be printed on a serial interface printer that is connected to the QSP-660 Serial Port. The log may also be sent to a host computer for storage or processing rather than a printer.

The Alarm Log can be cleared by pressing the **ZOOM** button.

Set Alarm Activation Type

1: Contact Closure
 2: Contact Closure
 3: Contact Closure
 4: Contact Closure

Camera: Select
 DISPLAY: Accept and Return

Alarm Log Page 1/1

Time	Date	Cam Type
12:07:39	23MAR98	Restore User

PIP:Next FREEZE:Print Log
 QUADRANT:Prev ZOOM:Clear Log
 DISPLAY: Return

Other Options

The Other Options menu provides access to the advanced QSP-660 systems options.

Selecting:

1. Toggles the IR remote control code setting between Code 1, Code 2, and remote Off. (See "Programming your ATV QSP-660 Remote Control" on page 17.)
2. Enters the Security Set Up menu for establishing a security lockout code.
3. Toggles On-screen text color between White, Light Grey, and Dark Grey.
4. Toggles the text background between On and Off.
5. **(VCR +1)** Toggles the VCR playback video format between field and frame.

Other Options	
1: Remote Control:	Code 2
2: Security Set Up . . .	
3: Text Color:	White
4: Text Background:	Off
5: VCR Playback:	Field
PIP: Restore ALL Settings to Factory Defaults	
Camera: Select	
5 is VCR + 1	
DISPLAY: Accept and Return	

Security Set Up

Security lockout is a means to disable the QSP-660 menus so that casual or inadvertent tampering can be prevented. It is not intended as a hard security measure and can be bypassed by removing the QSP-660 power followed by applying power and **simultaneously** pressing the **DISPLAY** button until the ATV name appears. This is not the preferred method of bypassing security because this step also returns all internal parameters and options to their factory defaults.

The security feature requires that a security code (password) of 1 to 9 digits be entered and verified. The security lockout does not become active until the menus have been exited. When Button Lock is turned on, it will disable all front panel operations. A long press of the **DISPLAY** button will still enable menus. Security IR Lock and Serial Lock, when On, will disable all IR remote button and serial interface operations respectively.

Security Set Up	
Menus are Unlocked	
1: Lock Menus	
2: Unlock Menus	
3: Button Lock:	Off
4: Security IR Lock:	Off
5: Serial Lock:	Off
Camera: Select	
5 is VCR + 1	
DISPLAY: Accept and Return	

HAND HELD IR REMOTE CONTROL

The hand held remote control allows easy remote operation of your QSP-660 by duplicating the front panel buttons as shown in the diagram. One major difference between front panel and remote operation is that the individual camera buttons have been reduced to a single button. In this case, the first press of the camera button will cause the QSP-660 to display camera 1. Additional button presses will cycle the selection through each available camera and back to camera 1.

Please note that the remote control may not work properly in the presence of strong sun light.

Programming your ATV QSP-660 Remote Control

When first installing or when changing the batteries in your QSP-660 Remote Control, it may be necessary to reprogram it for use with the QSP-660.

Note: If your remote control does not appear to work for any reason, please perform the following steps.

To program the remote control to work with the QSP-660:

1. Ensure that batteries are properly installed in the QSP-660 Remote Control.
2. Turn on the QSP-660 and connect a monitor.
3. On the QSP-660, press the **DISPLAY** button to return to **DISPLAY** mode. Then press any of the **1-4** buttons to call up a full screen picture.
4. On the remote control, press and hold the **VCR** button followed by the **DISPLAY**. Hold both buttons together until the indicator lights up and blinks twice.
5. Enter your five-digit code. The QSP-660 code set #1 equates to remote code 11414, and code set #2 equates to code set 11344. The red LED will now blink twice and the remote control is set. Your QSP-660 is factory set for Code set #2. See page 16 to change the QSP-660 Code set.

The codes are entered by using the four buttons shown in the above diagram (**Freeze, Camera, Quadrant, PIP**). For example, to enter the default code for a QSP-660 (code 11344) press the following:

Code set #1		Code set #2	
FREEZE	2 TIMES	FREEZE	2 TIMES
QUADRANT	1 TIME	PIP	1 TIMES
FREEZE	1 TIME	QUADRANT	2 TIMES
QUADRANT	1 TIME		

Press the **DISPLAY** button on the remote control for quad display on the QSP-660.

Note: After replacing the battery, you must re-program the remote.



ALARM INTERCONNECTION ON THE QSP-660

The alarm connector on the back panel allows input of four external control signals to affect the behavior of the real time quad under alarm conditions. Alarm inputs are provided for each camera. A picture freeze input is also provided to allow the picture to be frozen. These inputs are normally generated by a switch located at a door, window, or other point in the installation where a camera is monitoring activity. Many installations use an open switch that requires a switch closure to activate the alarm. As part of the QSP-660's normal alarm video processing, an alarm output is generated on the same back panel connector. In addition to the alarm inputs, a picture freeze input is also provided. While picture freeze is activated, any present camera image is retained on the display and new video information is ignored. A picture freeze does not trigger the alarm output.

Alarm inputs contain series resistors for ESD (Electro Static Discharge) and lightning damage protection. The outputs also contain series resistors to limit output current to prevent damage to the QSP-660 in the occurrence of shorting out the output pin.

Note: When connecting the inputs and outputs up to other equipment, consideration should be given to the limitations introduced by these current-limiting resistors.

The alarm connector on the QSP-660 is a DB-15, 15-pin connector. For ease of installation, a breakout adapter is provided with the 16th terminal connected to chassis ground. A simple alarm connection is shown to the right using the QSP-660 alarm breakout adapter. In the example to the right, switches are connected directly to the alarm inputs, and a single output is connected to some signaling device or to a controlled piece of equipment. In this case, an external resistor is required to pull the output up to +5V (High) indicating a non-alarm condition.

The external resistor makes connection to higher voltage systems possible, such as a 12 VDC automobile system. In this application, the pull-up resistor is not tied to the QSP-660 +5V pin, but to the higher voltage system. Voltages greater than +5V must not exceed 30 VDC and the current through the output pin must not exceed 50 mA.

Failure to remain within the 30 VDC and 50 mA restriction could damage either the QSP-660, the output signaling device, or both.

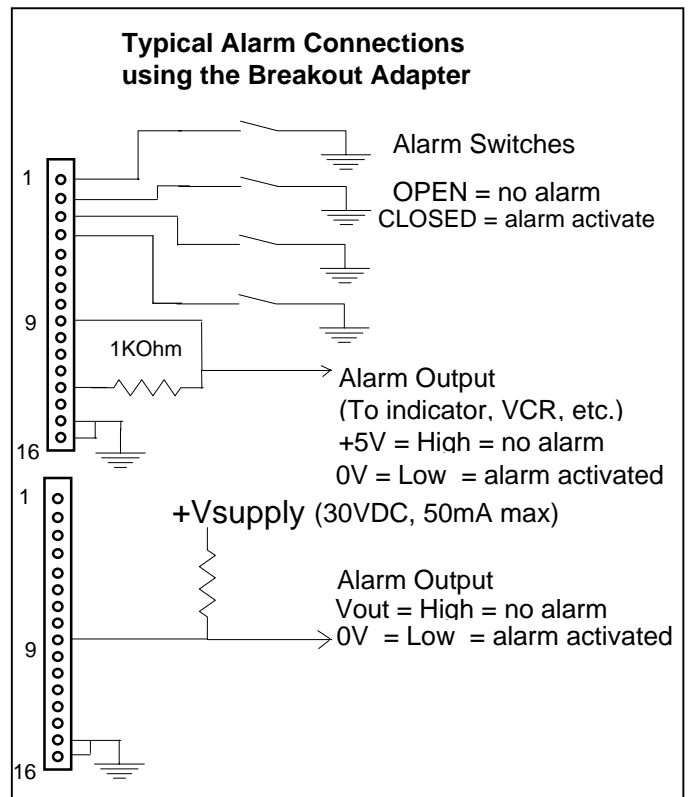
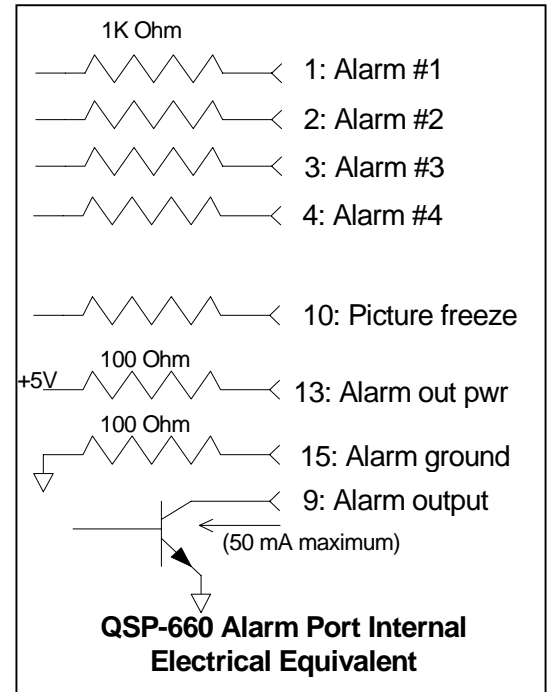

In some installations, the alarm output is used to activate or deactivate high voltage and/or high current circuitry (110 VAC lights, siren, etc.) which cannot be controlled directly by the QSP-660.

The easiest method to address the above cases is to use a relay, which has the number and rating on its contacts sufficient for the alarm output. Shown below are two methods to control a high current or high voltage device using a relay with a single, normally open contact. An internal, current limiting resistor for the pin 9 +5V supply will limit the usable relay current to something less than 10 mA (depending on the coil impedance). If a higher voltage or higher current relay is used, an external supply is required. Under these conditions the open circuit voltage (no alarm) on pin 9 must not exceed 30 VDC and the closed circuit current (alarm active) into pin 9 must be less than 50 mA.

The breakout adapter board is numbered compatibly with the DB-15 connector so the following table is applicable to either.

Note: Pin 16 is only present on the Breakout Adapter and is connected to chassis ground.

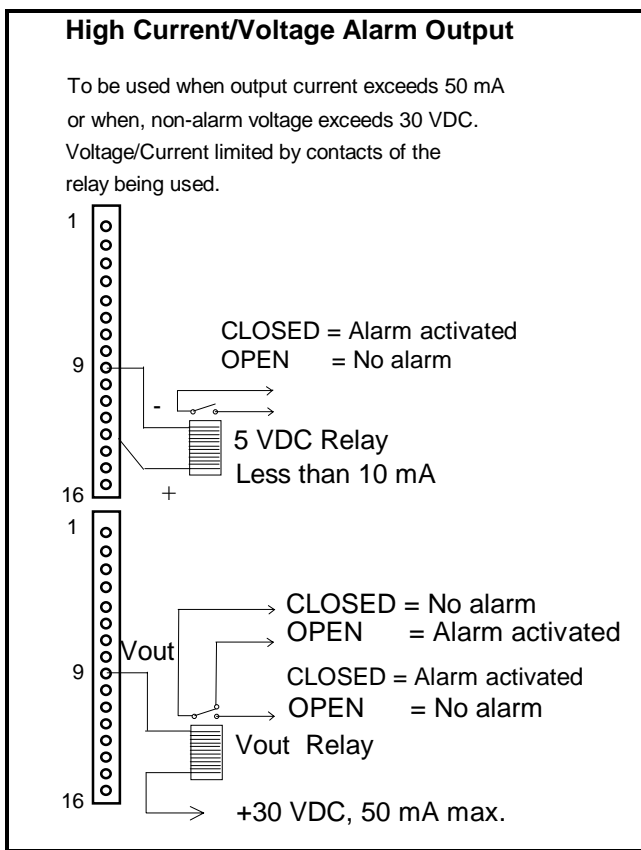

ALARM CONNECTOR PINS			
1	Alarm1	9	Alarm Out (< 50 mA)
2	Alarm2	10	Freeze/Master Enable
3	Alarm3	11	(reserved for future use)
4	Alarm4	12	(reserved for future use)
5	NA	13	+5V (< 10 mA)
6	NA	14	(reserved for future use)
7	NA	15	Signal ground (< 10 mA)
8	NA	16	Chassis ground

RS-232 REMOTE CONTROL INTERFACE

The QSP-660 has a built in RS-232 serial interface that supports remote control of the QSP-660 through simple ASCII commands. These commands provide access to the front panel button operations just as the IR Remote Control does.

The QSP-660 serial interface is fixed at 2400 baud, 8 bits, 1 stop bit, and no parity. It uses the very simple command format:

<command> <return>

The command is 2 character or 2 character plus parameter and must be followed by a carriage return. The QSP-660 will respond with:

- > if the command was recognized, or
- ? if the command was not recognized or is invalid

The following commands are supported by the QSP-660 serial interface and behave just as if the indicated front panel button was pushed:

- BD **Display** button
- BS **Sequence** button - will cause QSP-660 to start or stop sequencing during live mode.
- BP **PIP** button
- BQ **Quadrant** button
- BV **VCR** button - will cause the QSP-660 to enter or exit VCR playback mode
- BF **Freeze** button - will cause the QSP-660 to freeze during live mode
- BB **VCR** button - will cause the QSP-660 to enter the VCR bypass mode
- BC *n* **Camera** buttons - is a number 1 through 4 corresponding to the camera number. A space or tab must be entered between the command and the number.
- BZ **Zoom** button – will expand a quadrant of any image in playback. Repeated entries of this command will rotate through the quadrants.

Commands only take a fraction of a second to execute within the QSP-660. However, there must be a delay of at least 0.3 seconds (300 milliseconds) between the carriage return and start of the next command. The command decode prompt (>) may occur before the command has finished executing and should not be used as an indication to send the next command.

For proper RS-232 operation, the 8 position DIP switch, SW 5, located next to the DB-9 RS-232 interface connector within the QSP-660 must be set to the factory default positions as indicated below. The DB-9 connector pinout corresponds to a standard 9-pin DCE (modem) device.

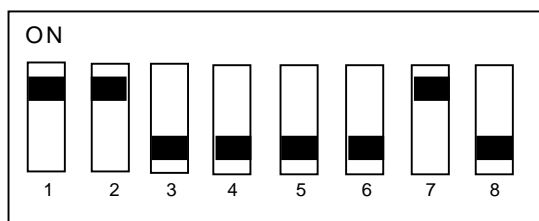

SW 5

SERIAL CONNECTOR PINS	
1	Signal ground
2	TX+ (out) RS232 or 422
3	RX+ (in) RS232 or 422
4	Signal ground
5	Signal ground
6	Signal ground
7	TX- (out) RS422
8	RX- (in) RS422
9	Signal ground

EQUIPMENT REQUIREMENTS

The QSP-660 is designed to be compatible with all EIA and CCIR compatible equipment. The QSP-660 will accept 2:1 interlace cameras in either a line-locked or free running (internal reference) modes. The use of random interlace camera is not recommended unless the line lock is turned off.

SPECIFICATIONS

Physical

Dimensions.....	11-5/16 w X 9 d X 2-3/8 h (288 mm X 229 mm X 61 mm)
Weight	2.6 lbs. (1.17 kg), Power Supply: 1.0 lbs. (0.45 kg)
Operating Temp	32°F - 104°F (0°C - 40°C)

Video

Signal Format	EIA/CCIR Compatible Monochrome EIA: 525 lines, 60 Fields / sec. CCIR: 625 lines, 50 Fields / sec.
Camera Inputs.....	0.6 to 1.2 Vp-p 75 Ohm Termination
Monitor Output.....	1.2 Vp-p into 75 Ohms
Digital Sampling	512H x 512V x 8 Bits (256 Gray Levels)
Refresh Rate	30 Fields Per Second (EIA) 25 Fields Per Second (CCIR)

Electrical

Power	12 V AC @ 2 Amp
Safety	110V, 60Hz Power Supply: UL Listed and CSA Certified 220V, 50Hz Power Supply: CE Mark and VDE approved
EMI	FCC Part 15, Class A CE Certified EN50081-1 (emissions), EN50082-1 (immunity)

Connectors

Video In	BNC, 1 Per Camera, Terminating, or Hi Z (4 Total)
Loop Thru	BNC, 1 Per Camera
Monitor Video Out	BNC
VCR Video Out.....	BNC
VCR Video In.....	BNC
Serial Port.....	DB9
Alarm	DB15 with Screw On Adapter Board
12 VAC, or 12 VDC	Power Jack, 0.080 Pin Diameter

Controls

DISPLAY	Return to Quad Display
SEQUENCE	Calls Up Selected Sequence Mode
FREEZE	Freeze current display image
PIP	Calls Up Next PIP Mode
QUADRANT	Rotates Quadrant
ZOOM.....	Activates Zoom
VCR	Enables/Disables VCR Input for Recorder Playback
FOUR CAMERA BUTTONS (1-4).....	Calls Up Individual Cameras Full Screen
IR Remote	Duplicates Front Panel Controls
Termination Switches.....	Selects 75 Ohm or Hi-Z Termination for 4 Video Inputs

WARRANTY INFORMATION

Thank you for purchasing this Advanced Technology Video, Inc., hereinafter ATV, product. We have manufactured this product in accordance with high quality standards and when used in the manner intended, it has a **limited warranty against defects in material and workmanship for a period of five (5) years from the date of shipment from ATV**. During the warranty period ATV's entire liability and your exclusive remedy shall be, at ATV's option, upon receipt of proof of purchase, repair or replacement of products that prove to be defective. Repair of a defective product is contingent upon availability of replacement parts from their manufacturer. Should ATV be unable to obtain replacement parts, ATV will, at its option, pro rate the value of the defective product and offer this amount toward the purchase of any new ATV product.

For warranty service or repair, this product must be returned to a service facility designated by ATV. Within the United States, you must obtain a return authorization (RMA) number by calling (888) 288-7644. Outside of the United States, contact your sales representative or the ATV factory at (425) 885-7000 (email: tech@atvideo.com). For ATV factory service after obtaining an RMA number, send the product with shipping charges and applicable duties and taxes paid, along with a copy of your sales receipt or other proof of purchase and date of purchase to the ATV factory address.

YEAR 2000 CONFORMANCE

All ATV products containing a date and time function meet Year 2000 Conformity Requirements as specified in BSI DISC PD2000-1 (described below). Year 2000 requirements do not apply to ATV products without a date and time function. ATV products' date format is Day – Month – Year where Year is a two-digit representation of the year. Conformity is defined as follows:

1. No value for the current date will cause any interruption in operation of the product.
2. Date-based functionality within the product behaves consistently for dates prior to, during and after year 2000.
3. The 2 digit date within the product is implicitly assumed to be greater than 1990.
4. Year 2000 is recognized as a leap year.

LIMITATION OF WARRANTY

This warranty covers normal use and does not cover damage which occurs in shipment or failure which results from alteration, accident, misuse, neglect, voltage fluctuations, lightning, water damage (or other acts of God), faulty installation or adjustment of controls, interfacing with non-standard or custom equipment, or improper maintenance.

EXCEPT AS HEREIN EXPRESSLY SET FORTH AND TO THE MAXIMUM EXTENT PERMITTED BY APPLICABLE LAW, ATV OR ANY OF ITS EMPLOYEES SHALL NOT, UNDER ANY CIRCUMSTANCES, BE RESPONSIBLE FOR ANY DIRECT, INDIRECT, INCIDENTAL OR CONSEQUENTIAL DAMAGES, INCLUDING, BUT NOT LIMITED TO, DAMAGE TO THE EQUIPMENT. ATV MAKES NO OTHER WARRANTIES, EXPRESS OR IMPLIED INCLUDING, BUT NOT LIMITED TO THE IMPLIED WARRANTIES OF MERCHANTABILITY, FITNESS FOR A PARTICULAR PURPOSE, TITLE, AND NON-INFRINGEMENT. REMOVAL OR ALTERATION OF THE SERIAL NUMBER WILL VOID THIS WARRANTY.

FCC STATEMENT

This equipment has been tested and found to comply with the limits for a class A digital device, pursuant to part 15 of the FCC Rules. These limits are designed to provide reasonable protection against harmful interference when the equipment is operated in a commercial environment. This equipment generates, uses, and can radiate radio frequency energy and, if not installed and used in accordance with the instruction manual, may cause harmful interference to radio communications. Operation of this equipment in a residential area is likely to cause harmful interference in which case the user will be required to correct the interference at his expense.

Free Manuals Download Website

<http://myh66.com>

<http://usermanuals.us>

<http://www.somanuals.com>

<http://www.4manuals.cc>

<http://www.manual-lib.com>

<http://www.404manual.com>

<http://www.luxmanual.com>

<http://aubethermostatmanual.com>

Golf course search by state

<http://golfingnear.com>

Email search by domain

<http://emailbydomain.com>

Auto manuals search

<http://auto.somanuals.com>

TV manuals search

<http://tv.somanuals.com>