



SkyIPCam1500W Wireless N Night Vision Network Camera

Model # AICN1500W

User's Manual

Ver. 1.0

CHAPTER 1	2
INTRODUCTION TO YOUR CAMERA.....	2
1.1 Checking the Package Contents.....	2
1.2 Getting to Know Your Camera	2
1.3 Features and Benefits.....	4
1.4 System Requirement	4
CHAPTER 2	5
HARDWARE INSTALLATION	5
2.1 Installing the Wall Mount Kit.....	5
2.2 Connecting the Camera to LAN/WLAN.....	5
2.3 Applications of the Camera.....	6
CHAPTER 3	7
SOFTWARE INSTALLATION	7
3.1 Installing SkyIPCam Utility and Ultraview	7
3.2 Configuring the Camera.....	10
3.3 Viewing Images.....	15
CHAPTER 4	17
CONFIGURATION	18
4.1 Using the Web Configuration	18
4.2 Basic Setup.....	18
4.3 Network Settings.....	21
4.4 Setting up Video & Audio	27
4.5 Event Server Configuration	29
4.6 Motion Detect.....	31
4.7 Event Configuration	32
4.8 Tools	35
4.9 Information.....	36
CHAPTER 5	37
USING SKYIPCAM ULTRAVIEW.....	37
5.1 Starting the Program.....	37
5.2 Main Window and Item Feature	38
5.3 Accessing the Camera.....	41
5.4 Recording / Playing Video.....	48
5.5 Configuring the eMap View Setting.....	52
5.6 Configuring the System.....	57
5.7 Event Configuration	61
5.8 Terminating Operation	64
APPENDIX	65
A.1 Specification.....	65
A.2 Glossary of Terms.....	66
TECHNICAL SUPPORT	71

CHAPTER 1

INTRODUCTION TO YOUR CAMERA

1.1 Checking the Package Contents

Check the items contained in the package carefully. You should have the following:

- ☑ One SkyIPCam1500W Wireless N Night Vision Network Camera.
- ☑ One Antenna.
- ☑ One AC Power Adapter.
- ☑ One Camera Stand.
- ☑ One Ethernet Cable (Cat.5).
- ☑ One Installation CD-ROM.
- ☑ One *Quick Installation Guide*.

NOTE Once any item contained is damaged or missing, contact the store where you purchased the product.

1.2 Getting to Know Your Camera

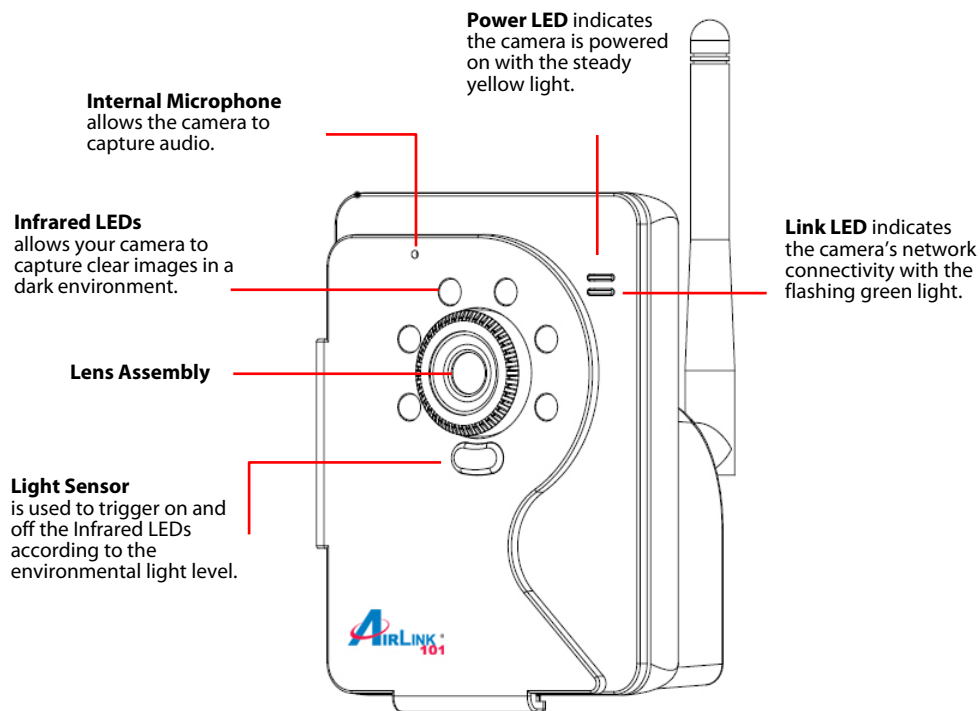

Front View

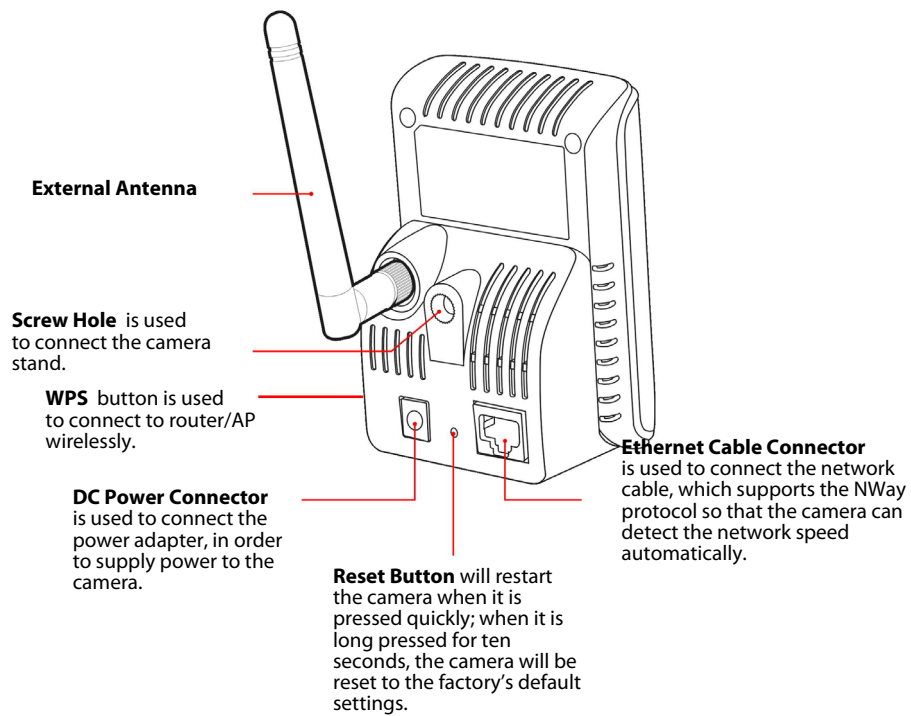

Rear View

1.3 Features and Benefits

- **Audio Capability**
The built-in microphone allows you to capture and monitor sounds and voices.
- **Day & Night Surveillance Supported**
The six Infrared LEDs around the standard lens assembly enable the camera to capture crystal clear images in dark environments or at night. When the Light Sensor detects low light levels, the camera captures the images in black & white mode using the infrared LEDs.
- **Remote Control Supported**
By using a standard Web browser or the bundled SkyIPCam View software application, the administrator can easily change the configuration of the camera via Intranet or Internet. In addition, the camera can be upgraded over the network when a new firmware is available. The users are also allowed to monitor the images and take snapshots via the network.
- **Multiple Platforms Supported**
The camera supports multiple network protocols, including TCP/IP, SMTP e-mail, HTTP, and other Internet related protocols. Therefore, you can use the camera in a mixed operating system environment, such as Windows 2000 and Windows XP.
- **Multiple Applications Supported**
With remote access technology, you can use the cameras to monitor various objects and places for your own purposes.
For example, babies at home, patients in the hospital, offices and banks, and so on. The camera can capture both still images and video clips, so that you can keep the archives and restore them at any time.

1.4 System Requirement

- **Networking**
LAN: 10Base-T Ethernet or 100Base-TX Fast Ethernet.
WLAN: 802.11b/g Wireless LAN
- **Accessing the Camera using Web Browser**
Platform: Microsoft® Windows® 2000/XP/Vista/Windows 7
CPU: Intel Pentium III 350MHz or above
RAM: 500MB
Resolution: 800x600 or above
User Interface: Microsoft® Internet Explorer 6.0 or above
Apple Safari 2 or above*
Mozilla Firefox 2 or above*
*Some web features not available
- **Accessing the Camera using SkyIPCam UltraView**
Platform: Microsoft® Windows® 2000/XP/Vista/Windows 7
Hardware Requirement:
1 camera connected: Intel Pentium III 800MHz; 512MB RAM
2 ~ 4 cameras connected: Intel Pentium 4 1.3GHz; 512MB RAM
5 ~ 8 cameras connected: Intel Pentium 4 2.4GHz; 1GB RAM
9 ~ 16 cameras connected: Intel Pentium 4 3.4GHz; 2GB RAM
Resolution: 1024x768 or above

NOTE If you connect multiple cameras and monitor them simultaneously, it is recommended that you use a computer with higher performance.

CHAPTER 2

HARDWARE INSTALLATION

2.1 Installing the Wall Mount Kit

The camera comes with a camera stand, which uses a swivel ball screw head to lock to the camera's screw hole. When the camera stand is attached, you can place the camera anywhere by mounting the camera through the three screw holes located in the base of the camera stand.

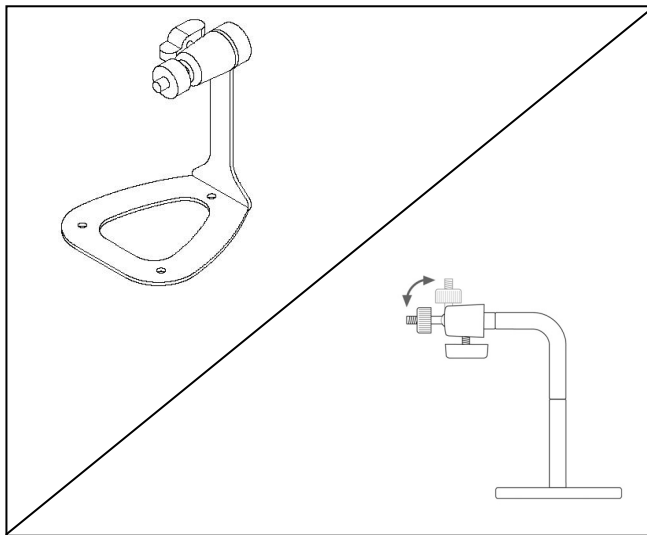

The Camera Stand

2.2 Connecting the Camera to LAN/WLAN

Use the provided Ethernet cable to connect the camera to your local area network (LAN).

When you connect the AC power adapter, the camera is powered on automatically. You can verify the power status from the Power LED on the front panel of the camera.

Once connected, the Link LED starts flashing green light and the camera is on standby and ready for use now.

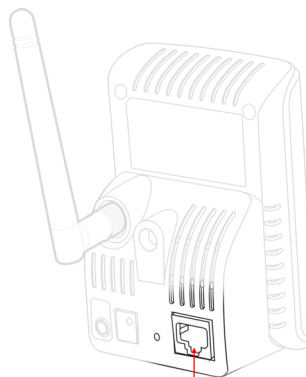

Connecting the Ethernet Cable

If you use a wireless network in your application environment, you need to attach the included external antenna to the camera.

When the camera is powered on, the camera will automatically search any access point with "default" SSID and with security encryption disabled.

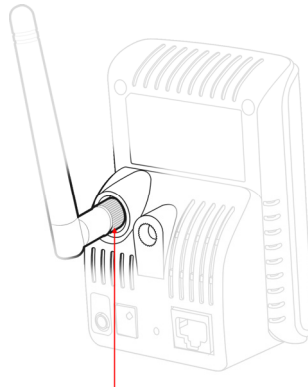

Connecting the Antenna

NOTE If the camera cannot connect to your wireless network, you need to connect the camera to LAN first and proceed with WLAN settings.

2.3 Applications of the Camera

The camera can be applied in multiple applications, including:

- Monitor local and remote places and objects via Internet or Intranet.
- Capture still images and video clips remotely.
- Upload images or send email messages with the still images attached.

The following diagram explains some of the typical applications for your camera and provides a basic example for installing the camera.

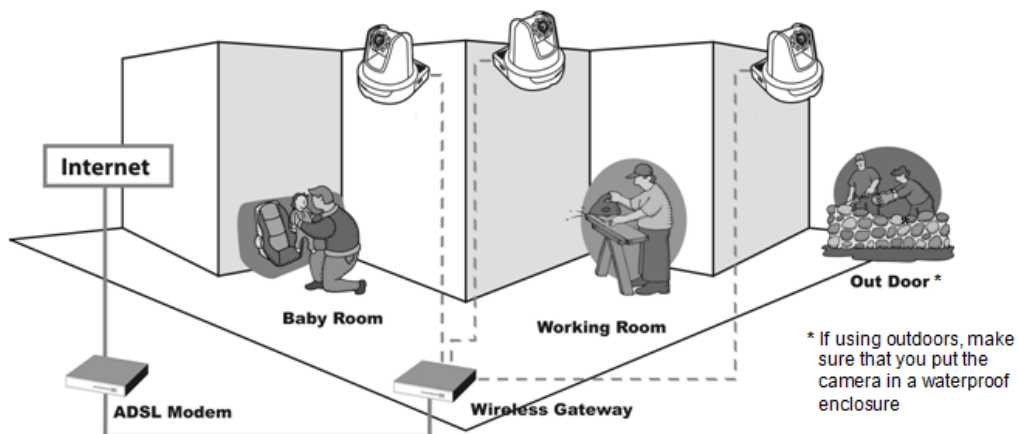

Home Applications

CHAPTER 3

SOFTWARE INSTALLATION

3.1 Installing SkyIPCam Utility and UltraView

Step 1 Insert the provided CD into your computer's CD ROM drive.

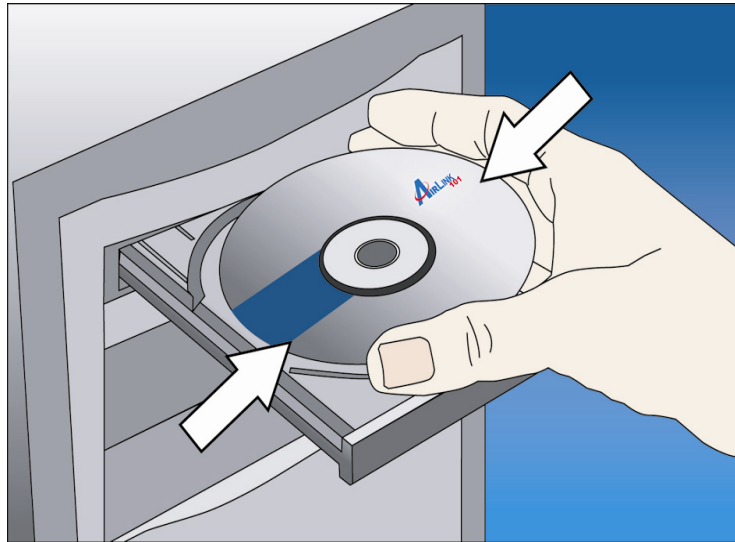

Step 2 Click on **Install Utility and Software**.

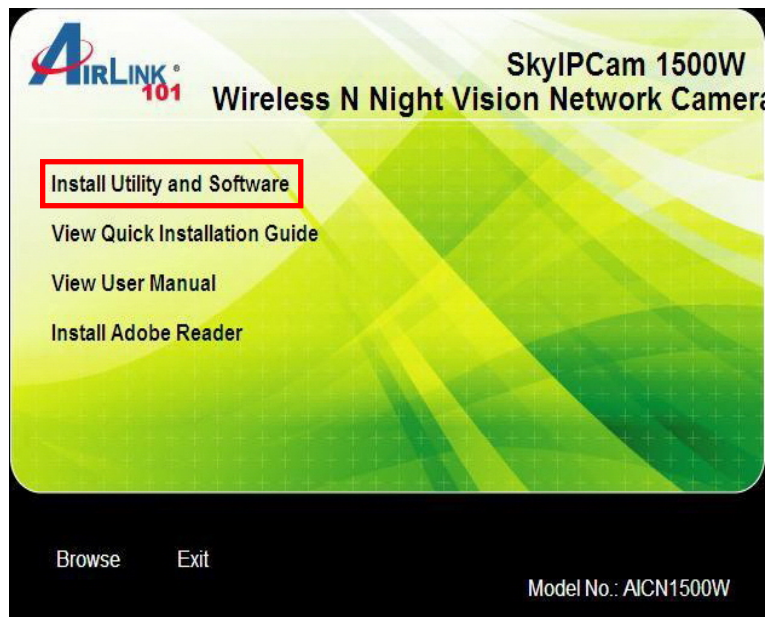

Note: If you do not see the autorun menu pops up on the screen, please go to your **CD-ROM drive > UltraView folder > run "Setup.exe"**.

Windows 7 and Vista users: an AutoPlay window pops up on screen, please make sure you give permission to run the setup program by clicking **Autorun.exe**.

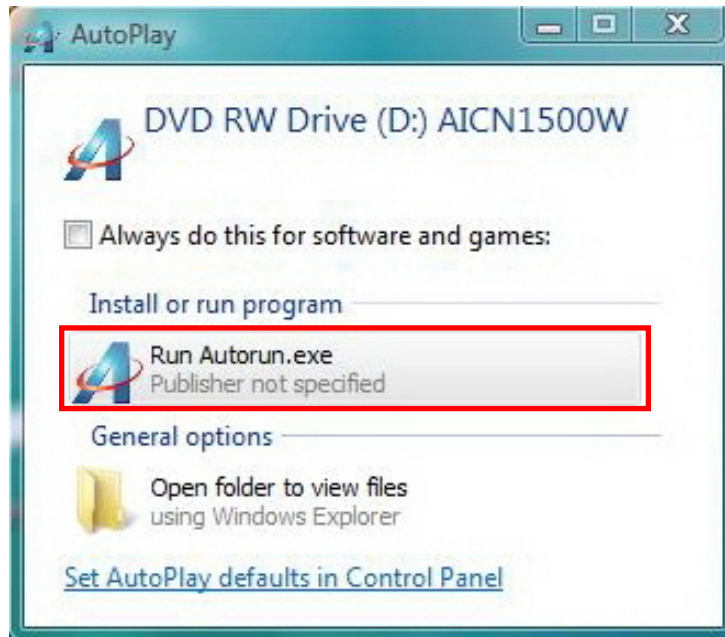

Step 3 Click **Install** to install the SkyIPCam utility and UltraView.

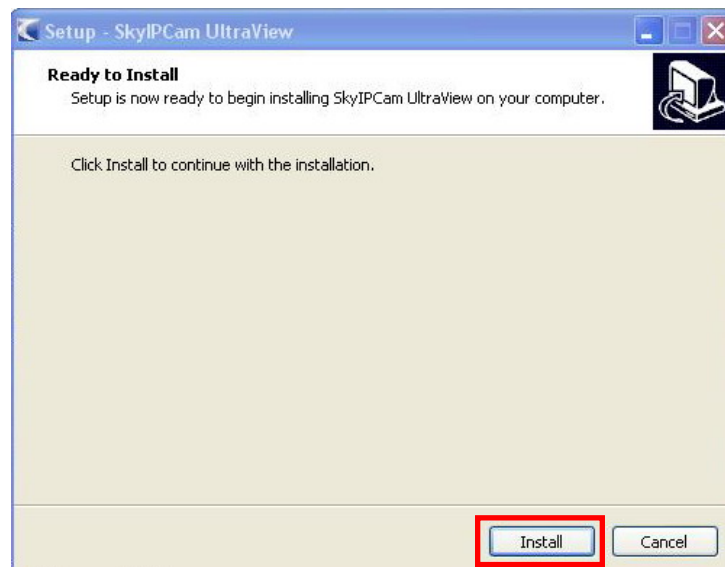

Step 4 Click **Finish** when installation finishes.

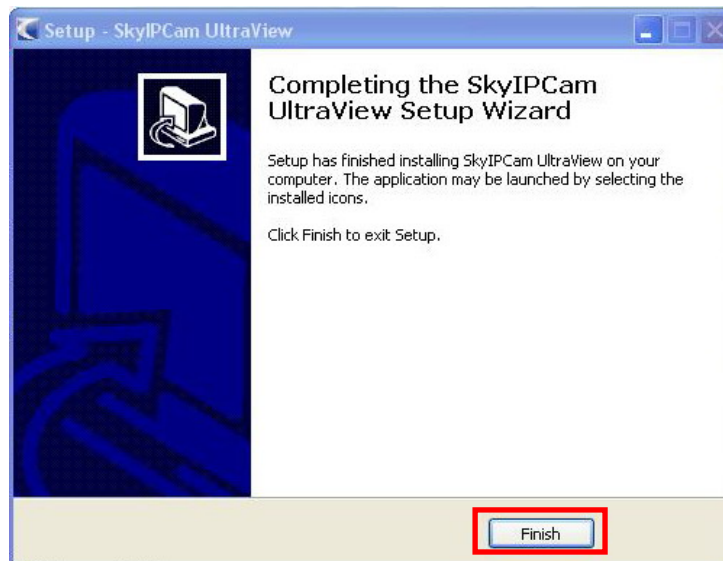

3.2 Configuring the Camera

Step 1 Go to **Start > (All) Programs > Airlink101 SkyIPCam UltraView > SkyIPCam Utiliy**

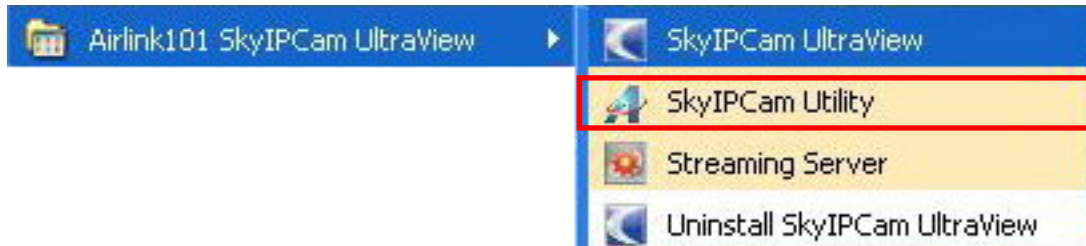

Step 2 Click on **Search** to find the camera on your network. Select the Camera you wish to configure and click on **Link**.

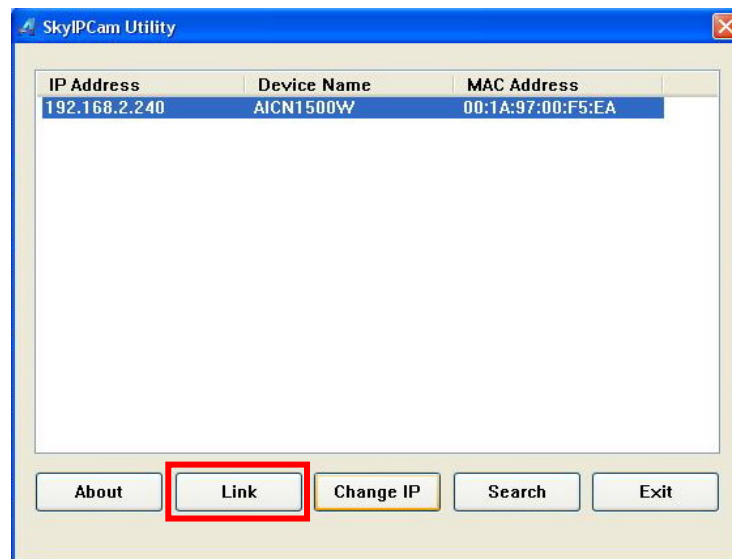

Note If the Camera you wish to configure does not show up in the utility, make sure the camera is properly connected to the same local network as your computer is, and the Green LED should be on. Click on **Search** to try again.

Step 3 When you are prompted for the user name and password, enter “**admin**” for both **User name** and **Password**, and click **OK**.



Connect to 192.168.2.240

SkyIPCam

User name: admin

Password:

Remember my password

OK Cancel

Step 4 The camera viewing window will appear. Click on **Setup**, then click on **Smart Wizard**.

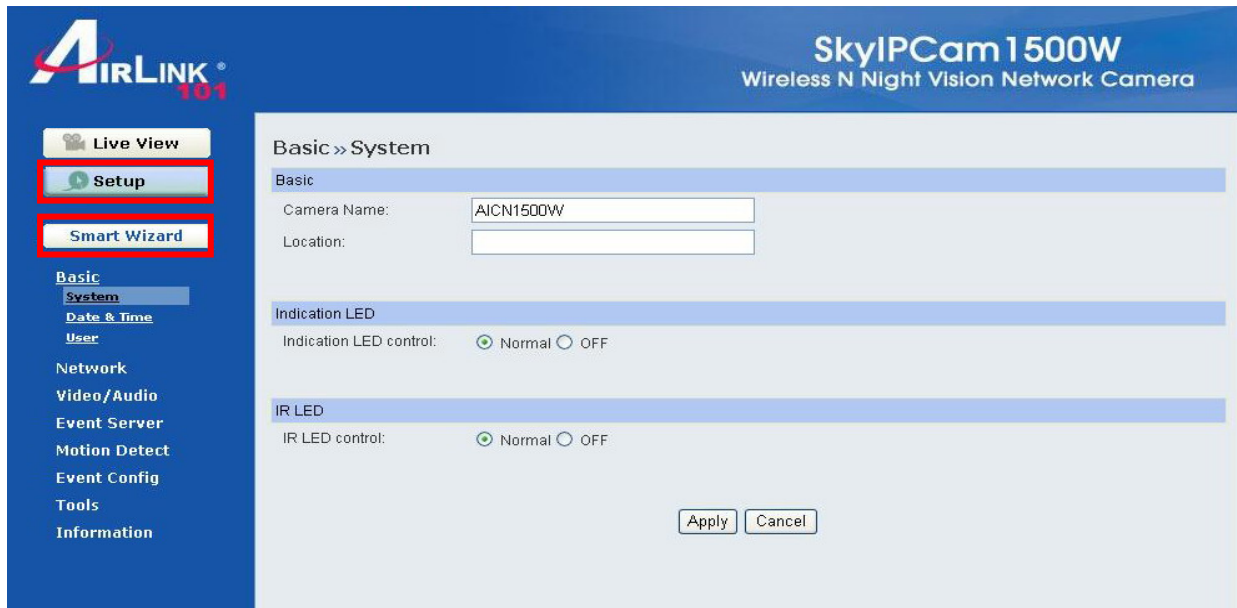

AIRLINK 101

SkyIPCam 1500W
Wireless N Night Vision Network Camera

Live View

Setup

Smart Wizard

Basic

System

Date & Time

User

Network

Video/Audio

Event Server

Motion Detect

Event Config

Tools

Information

Basic >> System

Basic

Camera Name: AICN1500W

Location:

Indication LED

Indication LED control: Normal OFF

IR LED

IR LED control: Normal OFF

Apply Cancel

Step 5 You may change the default **Camera Name** and enter a name for the **Location** if you like. Then enter “admin” for both **Admin Password** and **Confirm Password**. Click **Next**.

Step 6 You may simply accept the suggested default setting **DHCP** if your router’s **DHCP** server is enabled, so the router will automatically assign a dynamic **IP** address to your camera. Another option is to select **Static IP**, you can manually change the last 3-digit number of the IP Address, in case that the suggested one has already been used by another device in the same network. Enter IP, Subnet Mask, Default Gateway, Primary/Secondary DNS addresses here.

Note Be sure to enter Primary/Secondary DNS addresses assigned by your ISP if you set up Static IP for the camera so that the Email alert / FTP uploading can function properly.

Step 7 If you would like to set up email alerts that you can receive in the future, enter your email information here. You can get this information from your Email Service Provider. You can also set this up at a later time. Click **Next**.

SMTP Server Address: Enter the mail server address. For example, mymail.com.

Port Number: Enter the mail server port number.

Sender Email Address: Enter the email address of the user who will send the email. For example, John@mymail.com.

Authentication Mode: If the mail server needs to login, please select SMTP.

Sender User Name: Enter the user name to login the mail server.

Sender Password: Enter the password to login the mail server.

Receiver #1 Email Address: Enter the first email address of the user who will receive the email.

Receiver #2 Email Address: Enter the second email address of the user who will receive the email.

Step 8 Enter the Network ID (SSID) of your wireless network, or click on **Site Survey** and select from the list. Select the **Authentication** and **Encryption**, and enter the security **Key** of your wireless network. This information is stored in your wireless AP/router. Click **Next**.

Network ID(SSID): airlink101 Site Survey

Wireless Mode: Infrastructure Ad-Hoc

Channel: 6

Authentication: Open

Encryption: None WEP

Format: ASCII HEX

Key Length: 64 bits 128 bits

WEP Key 1

WEP Key 2

WEP Key 3

WEP Key 4

Step 9 Confirm your settings at this page. If everything is correct, click **Apply** to save the settings, then the camera will restart in 50 seconds.

Confirm Settings

Camera Name:	AICN1500W
Location:	
IP Mode:	DHCP
IP Address:	192.168.2.240
Subnet Mask:	255.255.255.0
Default Gateway:	192.168.2.1
Primary DNS:	
Secondary DNS:	
SMTP Server Address:	
Port Number:	25
Sender Email Address:	
Authentication Mode:	None
Sender User Name:	
Receiver #1 Email Address:	
Receiver #2 Email Address:	
ESSID:	airlink101
Connection:	Infrastructure
Channel:	6
Authentication:	Open
Encryption:	None

< Prev **Apply** Cancel

Step 10 After the camera is restarted, unplug the network cable from it. It will take around 1 or 2 minutes for the camera to connect wirelessly to your wireless router/AP.

To make sure the wireless connection is successfully established, open the **SkyIPCam Utility** and click on **Search**. If the camera shows up in the list, it is connected to your wireless network successfully. If not, please verify the SSID and the wireless security settings you configured at **Step 8** are correct.

3.3 Viewing Images

Method A > Access Camera from SkyIPCam Utility

Step 1A Open Airlink101 SkyIPCam Utility, select the camera you wish to connect to and click on **Link** button. Go to **Step 3**.

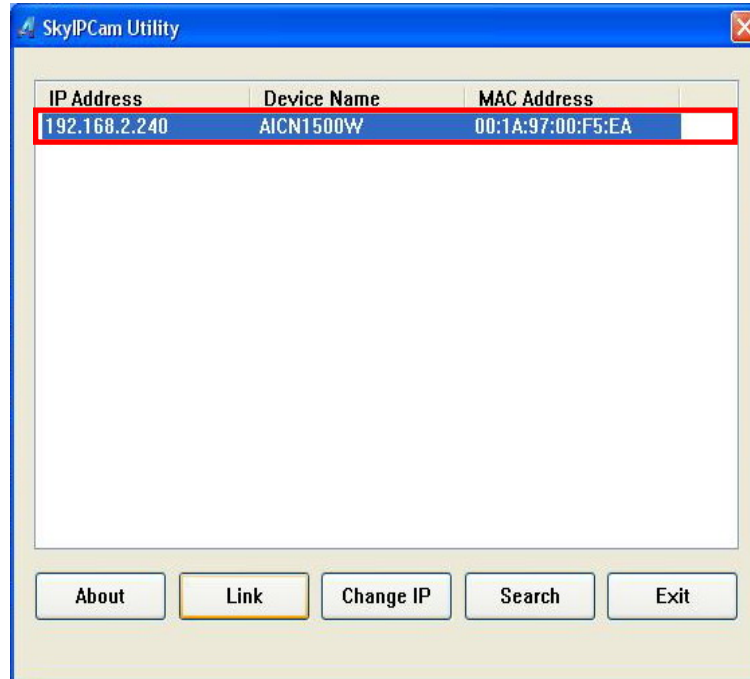

Method B > Access Camera from Web Browser

Step 1B If you assigned a static IP address for your camera (at Step 6, Chapter 3.2), you may open the Web Browser on your computer.

Step 2B Type the IP address of your camera in the Address bar, and press **Enter**.

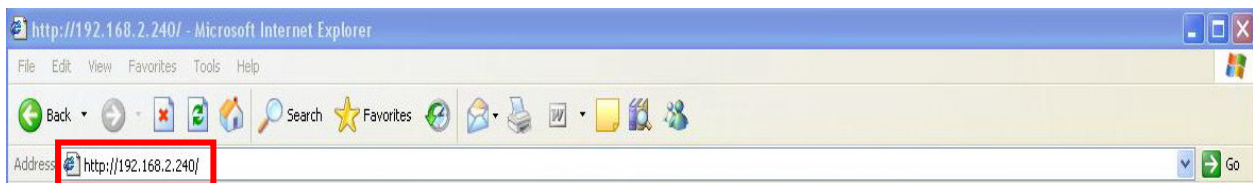

Step 3 Enter administrator's user name and password of the camera, then click **OK**. The default user name and password are both "**admin**" if you did not make any change to it at Step 5, Chapter 3.2.



Step 4 Internet Explorer User: If this is the first time for your computer to view image from the web configuration page, you will be prompted to install the ActiveX Control. Click on the bar on top of the screen and click on **Run Add-on** or **Install ActiveX Control** (depending on different IE versions).

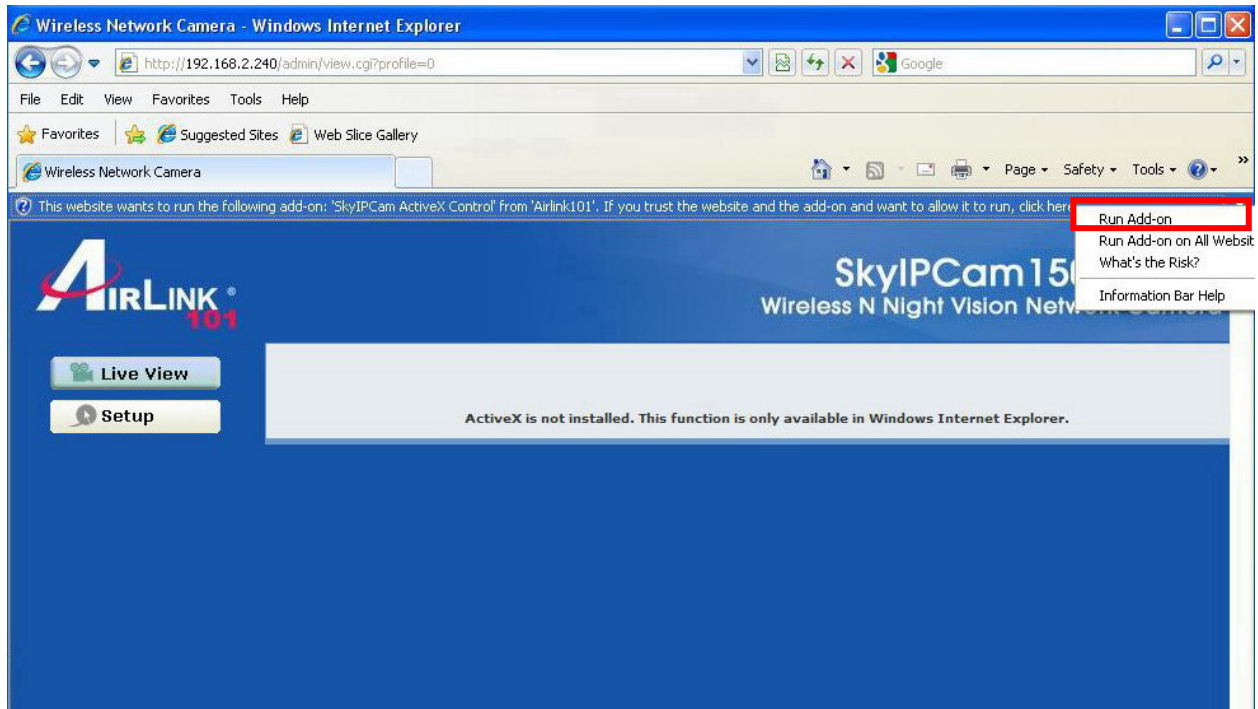

Step 5 Click on **Run**, then you will be able to view the image.



Note If you are using Mozilla Firefox or Safari and you are not able to view any image, please make sure you have Java and Quick Time add-ons installed.

Step 6 To get a clear view of images, you can simply rotate the camera's lens clockwise or counter-clockwise to adjust the focus.



CHAPTER 4

CONFIGURATION

4.1 Using the Web Configuration

You can access and manage the camera through the Web browser and the provided software application SkyIPCam UltraView. This chapter describes the Web Configuration, and guides you through the configuration of the camera by using the web browser.

To configure the camera, click **Setup** on the main page of Web Configuration. The Web Configuration will start from the **Basic** page.

4.2 Basic Setup

Basic >> System

The screenshot shows the web configuration interface for the SkyIPCam 1500W. The left sidebar contains a menu with the following items: Live View, Setup, Smart Wizard, Basic, System (highlighted with a red box), Date & Time, User, Network, Video/Audio, Event Server, Motion Detect, Event Config, Tools, and Information. The main content area is titled 'Basic >> System' and contains three sections: 'Basic' with fields for 'Camera Name' (AICN1500W) and 'Location'; 'Indication LED' with a radio button for 'Normal' (selected) and 'OFF'; and 'IR LED' with a radio button for 'Normal' (selected) and 'OFF'. 'Apply' and 'Cancel' buttons are at the bottom right.

The Basic menu contains three sub-menus that provide the system settings for the camera, such as the Camera Name, Location, Date & Time, and User management.

■ Basic

- **Camera Name:** Enter a descriptive name for the camera.
- **Location:** Enter a descriptive name for the location used by the camera.

■ Indication LED

This item allows you to set the Power LED's illumination as desired. There are two options: **Normal** and **OFF**.

■ IR LED

This item allows you to set the IR(Infrared) LED's illumination as desired. There are two options: **Normal** and **OFF**.

Basic >> Date & Time

Basic >> Date & Time

Date and Time

TimeZone: (GMT-08:00) Pacific Time(US & Canada); Tijuana

Automatically adjust clock for daylight saving time changes

Synchronize with PC

Synchronize with NTP Server:

NTP Server Address: 132.163.4.102 - North America

Update Interval: 6 hours

Manual

Date: 2007/01/01 (YYYY/MM/DD)

Time: 00:09:21 (hh:mm:ss)

Apply Cancel

■ Date & Time

- **TimeZone:** Select the proper time zone for the region from the pull-down menu.
- **Synchronize with PC:** Select this option and the date & time settings of the camera will be synchronized with the connected computer.
- **Synchronize with NTP Server:** Select this option and the time will be synchronized with the NTP Server. You need to select the proper IP address of the server and the update interval from the pull-down menu in the following two boxes.
- **Manual:** Select this option to set the date and time manually.

Basic >> User

The screenshot shows the 'Basic >> User' configuration interface. On the left is a blue sidebar with navigation options: 'Live View', 'Setup', 'Smart Wizard', and a menu containing 'Basic', 'System', 'Date & Time', 'User' (highlighted with a red box), 'Network', 'Video/Audio', 'Event Server', 'Motion Detect', 'Event Config', 'Tools', and 'Information'. The main content area is titled 'Basic >> User' and is divided into three sections: 'Administrator', 'General User', and 'Guest'. Each section contains input fields for 'Password', 'Confirm Password', 'User Name', and 'UserList', along with buttons for 'Modify', 'Add/Modify', and 'Delete'.

■ Administrator

You can use this option to change administrator's password for your camera.

■ General User

- **User Name:** Enter the user's name you want to add to use the camera.
- **Password:** Enter the password for the new user.

When you are finished, click **Add/Modify** to add the new user to the camera. To modify the user's information, select the one you want to modify from **UserList** and click **Add/Modify**.

- **UserList:** Display the existing users of the camera. To delete a user, select the one you want to delete and click **Delete**.

■ Guest

- **User Name:** Enter the guest's name you want to add to use the camera.
- **Password:** Enter the password for the new guest.
- **UserList:** Display the existing guests of the camera. To delete a user, select the one you want to delete and click **Delete**.

NOTE A "General User" can access the camera and control the Function buttons of the camera's Web Configuration; a "Guest" can only view the live view image from the main page of the Web Configuration while accessing the camera. Only the "Administrator" is allowed to configure the camera through the Web Configuration.

4.3 Network Settings

The Network menu contains three sub-menus that provide the network settings for the camera, such as the IP Setting, DDNS Setting, IP Filter, and Wireless Network.

Network >> Network

Network >> Network

IP Setting

DHCP
 Static IP

IP: 192 . 168 . 2 . 240
Subnet Mask: 255 . 255 . 255 . 0
Default Gateway: 192 . 168 . 2 . 1
Primary DNS:
Secondary DNS:

PPPoE

User Name:
Password:

DDNS Setting

Enable
Provider: dyndns.com
Host Name:
User Name:
Password:

UPnP

Enable

Ports Number

HTTP Port: 80 (default: 80)

Apply Cancel

■ IP Setting

This item allows you to select the IP address mode and set up the related configuration.

- **DHCP:** The default setting is DHCP and it uses your network's DHCP server. When the camera starts up, it will be assigned an IP address from the DHCP server automatically. Another option is to use Static IP, You should use Static IP mode to set a static IP so that the IP address will never change and you will always know what it is.
- **Static IP:** Select this option to assign the IP address for the camera directly. You can use SkyIPCam Utility to obtain the related setting values.

IP	Enter the IP address of the camera. The default setting is 192.168.2.240 .
Subnet Mask	Enter the Subnet Mask of the camera. The default setting is 255.255.255.0 .
Default Gateway	Enter the Default Gateway of the camera. The default setting is 192.168.2.1 .

Primary/ Secondary DNS	DNS (Domain Name System) translates domain names into IP addresses. Enter the Primary DNS and Secondary DNS that are provided by ISP. It is usually recommended that you input the Default Gateway of your network, which is the IP address of your router. Check with your router manufacturer for that information. THIS IS MANDATORY IF YOU WANT TO USE THE FTP OR EMAIL OPTIONS
-----------------------------------	--

- **PPPoE:** Select this option when you use a direct connection via the ADSL modem. You should have a PPPoE account from your Internet service provider. Enter the **User Name** and **Password**. The camera will get an IP address from the ISP as starting up. If you are using a router, you will NOT use this option.

NOTE Once the camera gets an IP address from the ISP as starting up, it automatically sends a notification email to you. Therefore, when you select PPPoE as your connecting type, you have to set up the email or DDNS configuration in advance.

■ **DDNS Setting**

With the Dynamic DNS feature, you can assign a fixed host and domain name to a dynamic Internet IP address. Select the **Enable** option to enable this feature. Then, select the Provider from the pull-down list and enter the required information in the **Host Name**, **User Name**, and **Password** boxes. Please note that you have to sign up for DDNS service with the service provider first. DDNS function on the camera is ONLY used if you are NOT using a NAT router and your camera has a public IP address. If you ARE using the camera with a NAT router, the camera's DDNS function will not work, and you will need to use the DDNS function in your router.

■ **UPnP**

The camera supports UPnP (Universal Plug and Play), which is a set of computer network protocols that enable the device-to-device interoperability. In addition, it supports port auto mapping function so that you can access the camera if it is behind a NAT router or firewall. Select the **Enable** option to enable this feature.

■ **Ports Number**

- **HTTP Port:** The default HTTP port is **80**. Some ISP's have port 80 blocked. If you are having problems, you can change it to some other port. The suggested port to be used is anything between 1024 to 65535

Network >> IP Filter

The screenshot shows the 'Network >> IP Filter' configuration page. On the left is a navigation menu with 'Live View', 'Setup', and 'Smart Wizard' buttons, and a tree view containing 'Basic', 'Network', 'IP Filter' (highlighted with a red box), and 'Wireless'. The main content area has a title 'Network >> IP Filter' and a sub-header 'IP Filter'. It contains three input sections: 'Start IP Address' with four empty boxes, 'End IP Address' with four empty boxes and an 'Add' button, and 'Deny IP List' with a dropdown arrow and a 'Delete' button.

The IP Filter setting allows the administrator of the camera to limit the users within a certain range of IP addresses to access the camera.

■ Start/End IP Address

Assign a range of IP addresses that are not allowed to access the camera by entering the Start IP address and End IP address. When you are finished, click **Add** to save the range setting. You can repeat the action to assign multiple ranges for the camera.

For example, when you enter 192.168.0.50 in Start IP Address and 192.168.0.80 in End IP Address, the users whose IP address located within 192.168.0.50 ~ 192.168.0.80 will not be allowed to access the camera.

■ Deny IP List

The list displays the range setting(s) of IP addresses that are not allowed to access the camera. To clear the setting, select a range of IP addresses from the list and click **Delete**.

Network >> Wireless Setting

The camera supports WLAN while you use the wireless network. Select the **Enable** option to enable this feature.

The camera supports Wireless feature that can connect to your wireless network. Select the **Enable** option to enable this feature.

- **Network ID (SSID):** Keep the default setting of this option to connect the camera to any access point under the infrastructure network mode. To connect the camera to a specified access point, set a SSID for the camera to correspond with the access point's ESSID. To connect the camera to an Ad-Hoc wireless workgroup, set the same wireless channel and SSID to match with the computer's configuration.

Click **Site Survey** to display the available wireless networks, so that you can easily connect to one of the listed wireless networks.

- **Wireless Mode:** Select the type of wireless communication for the camera: **Infrastructure** or **Ad-Hoc**.
- **Channel:** Select the appropriate channel from the list.
- **Authentication:** Select the authentication method to secure the camera from being used by unauthorized user: **Open**, **Shared-key**, **WPA-PSK**, and **WPA2-PSK**. The following table explains the four options:

Open	The default setting of Authentication mode, which communicates the key across the network.
Shared-key	Allow communication only with other devices with identical WEP settings.
WPA-PSK/ WPA2-PSK	WPA-PSK/WPA2-PSK is specially designed for the users who do not have access to network authentication servers. The user has to manually enter the starting password in their access point or gateway, as well as in each PC on the wireless network.

If you select **Open** or **Shared-key** as the Authentication mode, you need to complete the following settings:

Authentication:

Encryption: None WEP

Format: ASCII HEX

Key Length: 64 bits 128 bits

WEP Key 1

WEP Key 2

WEP Key 3

WEP Key 4

- **Encryption:** Select the **WEP** option to enable the data encryption feature to secure the camera within the wireless network.
- **Format:** Once you enable the Encryption feature, you need to determine the encryption format by selecting **ASCII** or **HEX**. ASCII format causes each character you type to be interpreted as an eight-bit value. Hex format causes each pair of characters you type to be interpreted as an eight-bit value in hexadecimal (base 16) notation.
- **Key Length:** Select the WEP key length you use: **64 bits** or **128 bits**.
- **WEP Key 1/2/3/4:** Enter the WEP key(s) in the following boxes. This must match the WEP key value configured for your wireless router/AP.

If you select **WPA-PSK** or **WPA2-PSK** as the Authentication mode, you need to complete the following settings:

Authentication:

Encryption: TKIP AES

Pre-Shared Key:

- **Encryption:** Select **TKIP** or **AES**. TKIP (Temporal Key Integrity Protocol) changes the temporal key every 10,000 packets to insure much greater security than the standard WEP security. AES (Advanced Encryption Standard) is used to ensure the highest degree of security and authenticity for digital information. This must match the encryption type configured for your wireless router/AP.
- **Pre-Shared Key:** Enter your wireless network key into the box, and this must match the Pre-shared key value configured for your wireless router/AP.

Network >> Wireless >> WPS Setting

Network · Wireless · WPS Setting

PROTECTED SETUP

Reset To Unconfigured

WPS

PIN Mode:

PIN Code: 00639392

Registrar ID(SSID):

PBC Mode:

Device Status

Device Idle

The camera supports WPS (WiFi Protected Setup™) feature that allows your camera to connect to the wireless network easily and safely without manually configuring the wireless security settings. **Please note that Your AP/Router must support WPS feature as well. If you are not sure, please refer to the manufacturer's manual of your AP/Router.**

Select either PIN or PBC mode to start the WPS session:

- **Select PIN Mode:**

- Step 1 Enter the SSID of the AP/Router you wish to connect to, or click **Site Survey** and select from the listed wireless networks.
- Step 2 Go to the WPS section of your AP/Router's web configuration page, then enter the PIN Code generated by the camera (in this case, "00639392") into the corresponding field. Please check your AP/Router's manufacturer's manual for more details.

- **Select PBC Mode (Recommended):**

- Step 1 Click on the Connect button on this page or push the WPS button on the backside of the camera.
- Step 2 Push the WPS hardware button on your AP/Router or the WPS software button in the web configuration page of your AP/Router.

Within 2 minutes, the camera will be wirelessly associated with your AP/Router.

4.4 Setting up Video & Audio

The Video & Audio menu contains three sub-menus that provide the video and audio settings for the camera.

Video & Audio >> Camera

The screenshot displays the 'Video & Audio >> Camera' configuration interface. On the left is a navigation menu with options like 'Live View', 'Setup', 'Smart Wizard', and various settings categories. The main area shows a live camera feed of a 'SkyIPCam1500W' camera box. Below the feed, the 'Image Setting' section allows adjustment of Brightness (50), Contrast (32), and Saturation (36), with a 'Default' button. It also features 'Mirror' options (Vertical/Horizontal) and 'Light Frequency' (50Hz, 60Hz, Outdoor). The 'Overlay Setting' section has 'Include Date & Time' checked and 'Enable Opaque' unchecked. 'Apply' and 'Cancel' buttons are at the bottom.

■ Image Setting

- **Brightness:** Adjust the brightness level from 0 ~ 100.
- **Contrast:** Adjust the contrast level from 0 ~ 100.
- **Saturation:** Adjust the colors level from 0 ~ 100.
Click **Default** to restore the default settings of the three options above.
- **Mirror:** Select the **Horizontal** option to mirror the image horizontally. Select the **Vertical** option to mirror the image vertically.
- **Light Frequency:** Select the proper frequency according to the camera's location: **50Hz**, **60Hz**, or **Outdoor**.

■ Overlay Setting

- **Includes Date & Time:** Select this option to display the date & time stamp on the live view image.
- **Enable Opaque:** Select this option to set a black background to the displayed date & time stamp.

Video & Audio >> Video

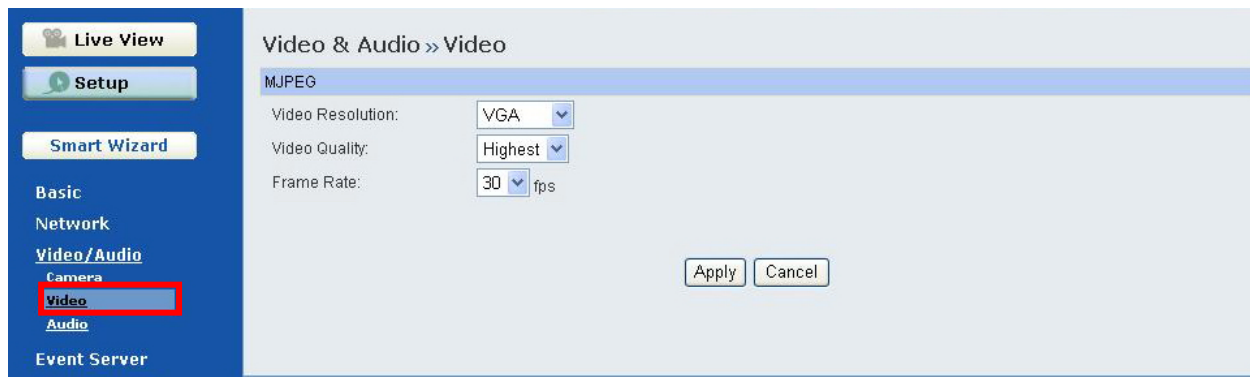

■ MJPEG

- **Video Resolution:** Select the desired video resolution from the three formats: **VGA**, **QVGA** and **QQVGA**. The higher setting (VGA) obtains better video quality while it uses more resource within your network.
- **Video Quality:** Select the desired image quality from five levels: **Lowest**, **Low**, **Medium**, **High**, and **Highest**.
- **Frame Rate:** Select **Auto** or a proper setting depending on your network status.

Video & Audio >> Audio

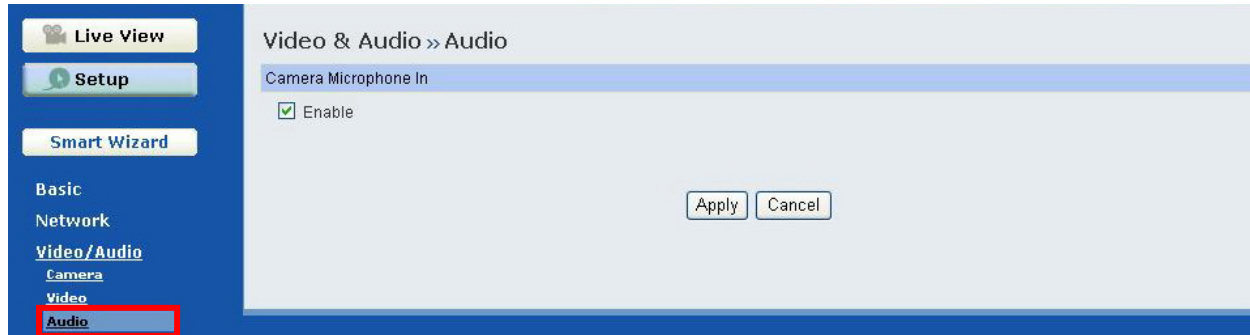

■ Camera Microphone In

Select the **Enable** option to enable the camera's audio function, so that you can receive the on-site sound and voice from the camera.

4.5 Event Server Configuration

The Event Server menu contains two sub-menus that allow you to upload images to FTP, and send emails that include still images.

When you complete the required settings for FTP, or Email, click **Test** to find out if the related configuration is correct or not. Once the camera connects to the server successfully, click **Apply**.

Event Server Setting>> FTP

Event Server Setting >> FTP

FTP

Host Address:

Port Number:

User Name:

Password:

Directory Path:

Passive mode: Enable

■ FTP

- **Host Address:** Enter the IP address or domain name of the target FTP server. If you enter the domain name, you **MUST** configure DNS settings in Network / IP Setting first.
- **Port Number:** Enter the port number used for the FTP server.
- **User Name:** Enter the user name to login into the FTP server.
- **Password:** Enter the password to login into the FTP server.
- **Directory Path:** Enter the destination folder for uploading the images. For example, */Test/*.
- **Passive Mode:** Select the **Enable** option to enable passive mode. If you are having trouble, you can enable/disable this mode.

Event Server Setting >> Email

Event Server Setting >> Email

Email

SMTP Server Address:

Port Number:

Sender Email Address:

Authentication Mode: None SMTP

Sender User Name:

Sender Password:

Receiver #1 Email Address:

Receiver #2 Email Address:

■ Email

- **SMTP Server Address:** Enter the mail server address. For example, [mymail.com](#).
- **Sender Email Address:** Enter the email address of the user who will send the email. For example, [John@mymail.com](#).
- **Sender User Name:** Enter the user name to login the mail server.
- **Sender Password:** Enter the password to login the mail server.
- **Receiver #1 Email Address:** Enter the first email address of the user who will receive the email.
- **Receiver #2 Email Address:** Enter the second email address of the user who will receive the email.

4.6 Motion Detect

**This function can only be configured in Windows Internet Explorer.*

The Motion Detect menu contains the command and option that allow you to enable and set up the motion detection feature of the camera. The camera provides two detecting areas.

To enable the detecting area, select **Window 1** or **2** from the pull-down list, and then check **Enable**. When the detecting area is enabled, you can use the mouse to move the detecting area and change the area coverage.

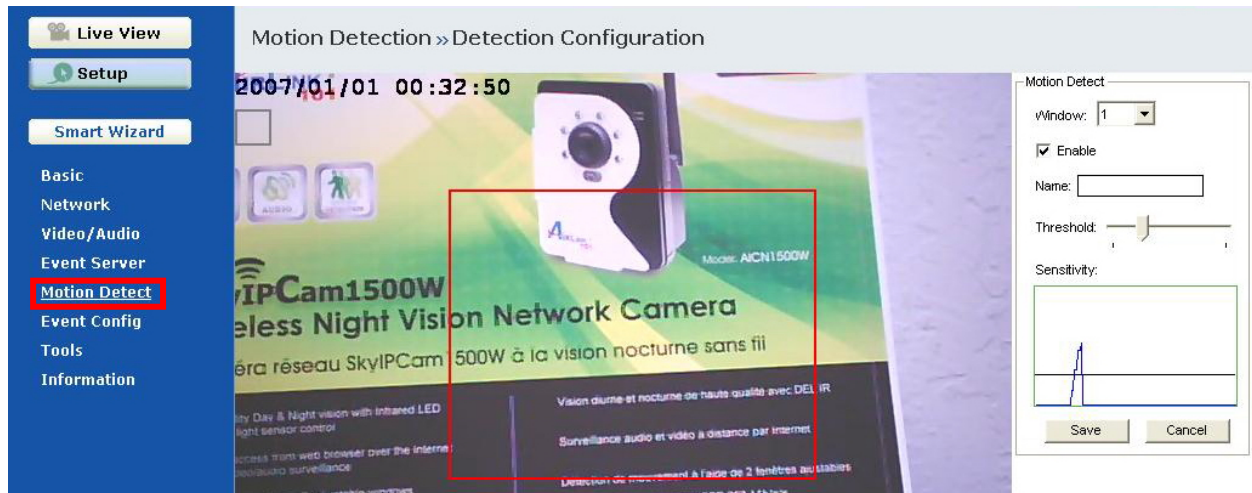

- **Name:** Assign a name to the detecting area.
- **Threshold:** Move the slide bar to adjust the sensitivity of motion detection. Make sure the threshold (the horizontal line) is low (sensitive) enough to come across the waves (appear when motion detected), so that the events (i.e, emailing snapshot, FTP uploading) you set up in **Event Config** will be triggered.

NOTE Sliding the Threshold bar to the right will decrease the sensitivity of motion detection; sliding the Threshold bar to the left will increase the sensitivity of motion detection.

4.7 Event Configuration

The Event Config menu contains five sub-menus that provide the commands to configure event profiles.

Event Configuration >> General Setting

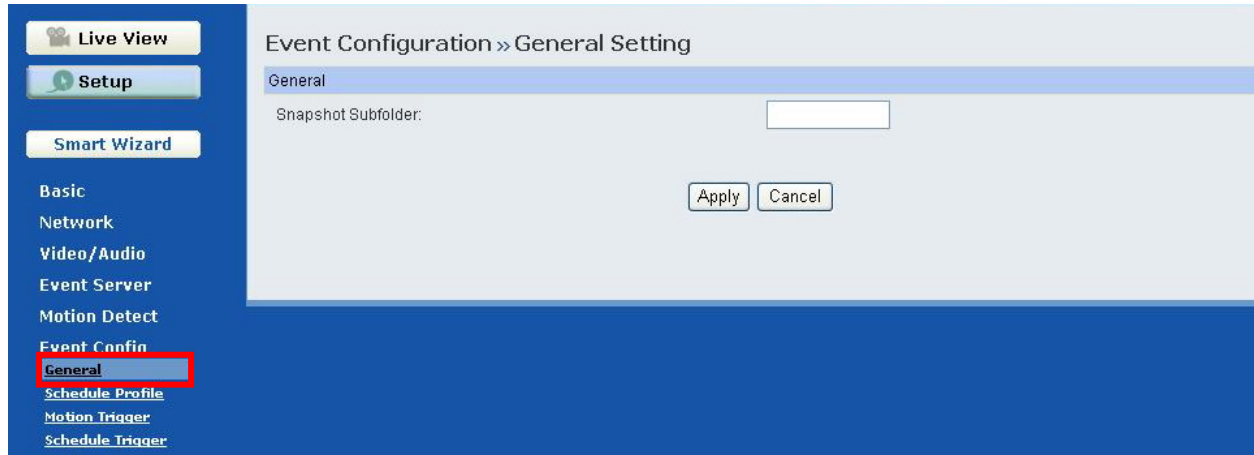

The screenshot displays the 'Event Configuration >> General Setting' window. On the left, a blue sidebar contains several menu items: 'Live View', 'Setup', 'Smart Wizard', 'Basic', 'Network', 'Video/Audio', 'Event Server', 'Motion Detect', 'Event Config', 'General' (highlighted with a red box), 'Schedule Profile', 'Motion Trigger', and 'Schedule Trigger'. The main content area is titled 'Event Configuration >> General Setting' and shows the 'General' tab selected. Underneath, there is a label 'Snapshot Subfolder:' followed by an empty text input field. At the bottom of the main area, there are two buttons: 'Apply' and 'Cancel'.

- **Snapshot/Recording Subfolder:** You can assign a descriptive name for the subfolder to save the captured image/video files. Otherwise, leave this option blank to use the default setting.

Event Configuration >> Arrange Schedule Profile

This sub-menu displays the scheduled profile(s). To customize the profile, click **Add** and then enter a descriptive name for the profile in the prompt dialog window. After entering the profile name, click **OK** and the profile is added to the Schedule Profiles list. To delete the profile, select the profile in the list and click **Delete**.

The screenshot shows the 'Event Configuration >> Arrange Schedule Profile' window. On the left is a blue sidebar with navigation buttons: 'Live View', 'Setup', 'Smart Wizard', and a list of menu items including 'Basic', 'Network', 'Video/Audio', 'Event Server', 'Motion Detect', 'Event Config', 'General', 'Schedule Profile' (highlighted with a red box), 'Motion Trigger', 'Schedule Trigger', 'Tools', and 'Information'. The main window title is 'Event Configuration >> Arrange Schedule Profile'. Below the title is a 'Schedule Profile' section containing a list box with 'profile1' and 'Add' and 'Delete' buttons. Below that is a configuration area for the selected profile. It includes a 'Profile Name' field with 'profile1', a 'Days' section with radio buttons for Sun (selected), Mon, Tue, Wed, Thu, Fri, and Sat. There is a 'Time List' section with an empty list box and 'Add', 'Delete', 'Copy this to all week days', and 'Delete this from all week days' buttons. At the bottom are 'Start Time' and 'End Time' fields, each with hour and minute input boxes, and 'Save' and 'Cancel' buttons.

- **Profile Name:** Display the profile name that you select in the Schedule Profiles list.
- **Days:** Select the day(s) that you want to separately assign in the schedule profile. The day that has been assigned will be displayed with green color.
- **Time List:** Display the time period that you have assigned within the selected weekday. To assign the same time period to every day, click **Add this to all week days**; click **Delete this from all week days** to remove the selected time period from every day. Click **Delete** to remove the selected time period.
- **Start/End Time:** Enter the start and end time and then click **Add** to assign a time period within the selected day.

Event Configuration >> Motion Detection Trigger

Select the **Enable** option to enable the motion detection trigger function of the camera, so that you can send captured images within the detecting area to the FTP server or email receiver. You have to configure corresponding settings, such as FTP server and email server, to enable this feature.

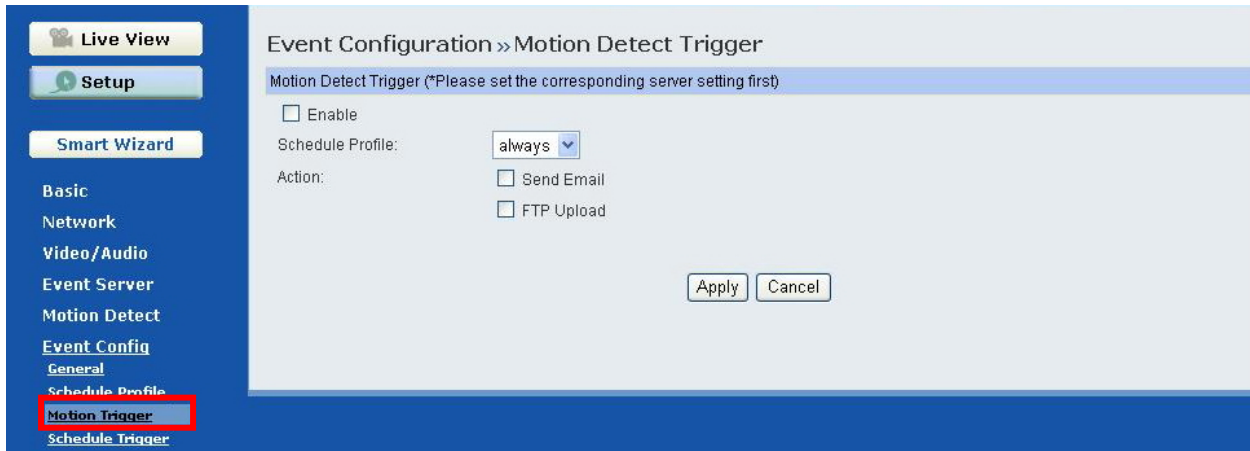

The screenshot shows the 'Event Configuration >> Motion Detect Trigger' page. On the left is a navigation menu with options: Live View, Setup, Smart Wizard, Basic, Network, Video/Audio, Event Server, Motion Detect, Event Config (with sub-items: General, Schedule Profile, Motion Trigger, Schedule Trigger), and Tools. The 'Motion Trigger' item is highlighted with a red box. The main content area has a title 'Event Configuration >> Motion Detect Trigger' and a sub-header 'Motion Detect Trigger (*Please set the corresponding server setting first)'. Below this are the following settings: an 'Enable' checkbox (unchecked), a 'Schedule Profile' dropdown menu set to 'always', and an 'Action' section with two checkboxes: 'Send Email' (unchecked) and 'FTP Upload' (unchecked). At the bottom right are 'Apply' and 'Cancel' buttons.

- **Schedule Profile:** Select a schedule profile from the pull-down list.
- **Action:** Select the destination of the captured images: **Send Email**, or **FTP Upload**.

Event Configuration >> Schedule Trigger



The screenshot shows the 'Event Configuration >> Schedule Trigger' page. The navigation menu on the left is similar to the previous page, but the 'Schedule Trigger' item is highlighted with a red box. The main content area has a title 'Event Configuration >> Schedule Trigger' and a sub-header 'Email Schedule'. Below this are the following settings: an 'Enable' checkbox (unchecked), a 'Schedule Profile' dropdown menu set to 'always', and an 'Interval' input field set to '20' with the unit 'secs'. Below the 'Email Schedule' section is the 'FTP Schedule' section, which includes an 'Enable' checkbox (unchecked), a 'Schedule Profile' dropdown menu set to 'always', and an 'Interval' section with two radio buttons: one selected for '30' with the unit 'secs /frame', and another for '1' with the unit 'frames /sec'. At the bottom right are 'Apply' and 'Cancel' buttons.

You can separately configure the schedule for trigger function of the camera by **Email**, or **FTP**. Select the **Enable** option on each item, and then select a **Schedule Profile** from the pull-down list and set the **Interval** time.

4.8 Tools

The Tools menu provides the commands that allow you to restart or reset the camera. You can also backup and restore your configuration, and upgrade the firmware for the camera.

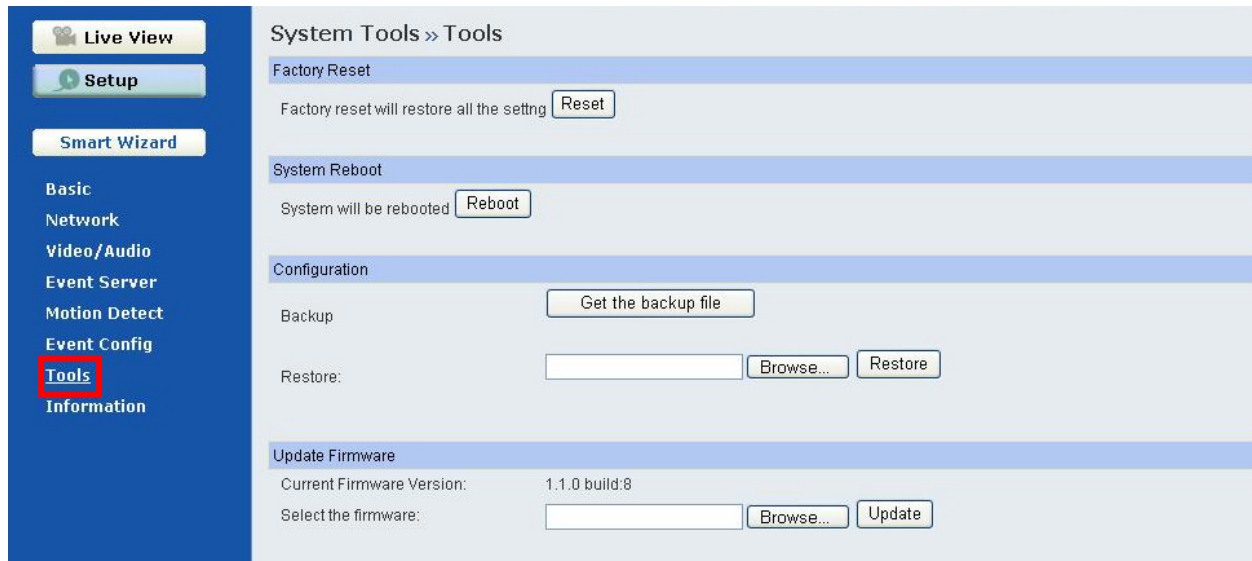

■ Factory Reset

Click **Reset** to restore all factory default settings for the camera.

■ System Reboot

Click **Reboot** to restart the camera just like turning the device off and on. The camera configuration will be retained after rebooting.

■ Configuration

You can save your camera configuration as a backup file on your computer. Whenever you want to resume the original settings, you can restore them by retrieving the backup file.

- **Backup:** Click **Get the backup file** to save the current configuration of the camera.
- **Restore:** Click **Browse** to locate the backup file and then click **Restore**.

■ Update Firmware

This item displays the current firmware version. You can upgrade the firmware for your camera once you obtained a latest version of firmware.

- **Select the firmware:** Click **Browse** to locate the backup file and then click **Update**.

NOTE Make sure to keep the camera connected to the power source during the process of upgrading firmware. Otherwise, the camera might be damaged because of failure of upgrading firmware.

4.9 Information

The Information menu displays the current configuration and events log of the camera.

System Information >> Device Information

Basic

Camera Name: AICN1500W
Location:
Firmware Version: 1.1.0 build: 8

Video & Audio

MJPEG Resolution: VGA
Microphone In: Enable

Network

IP Mode: DHCP
IP Address: 192.168.2.240
Subnet Mask: 255.255.255.0
Default Gateway: 192.168.2.1
MAC Address: 00:1A:97:00:F5:EA
Primary DNS Address:
Secondary DNS address:
UPnP Enable: Enable
HTTP Port: 80

Wireless

ESSID: airlink101
Connection: Infrastructure
Channel: Not Connected
Authentication: Open
Encryption: None

■ Device Info

Display the Basic, Video & Audio, and Network settings of the camera.

System Information >> Logs

Logs table

Refresh

Time	Event
Jan 1 00:09:40	UPnP port mapping setting fail
Jan 1 00:08:45	UPnP port(80) mapping setting start
Jan 1 00:07:45	UPnP port mapping setting fail
Jan 1 00:06:50	UPnP port(80) mapping setting start
Jan 1 00:05:49	UPnP port mapping setting fail
Jan 1 00:04:54	UPnP port(80) mapping setting start
Jan 1 00:03:53	UPnP port mapping setting fail
Jan 1 00:03:47	NTP date/time setting fail
Jan 1 00:02:58	UPnP port(80) mapping setting start
Jan 1 00:02:17	NTP date/time setting fail
Jan 1 00:01:58	UPnP port mapping setting fail
Jan 1 00:01:07	UPnP port(80) mapping setting start

■ System Log

The Logs table displays the events log recorded by the system.

CHAPTER 5

USING SKYIPCAM ULTRAVIEW

5.1 Starting the Program

To start UltraView Pro, click **Start → (All) Programs → Airlink101 SkyIPCam UltraView → SkyIPCam UltraView**. Alternatively, you can start the program by simply double-clicking the program icon on the desktop of your computer.

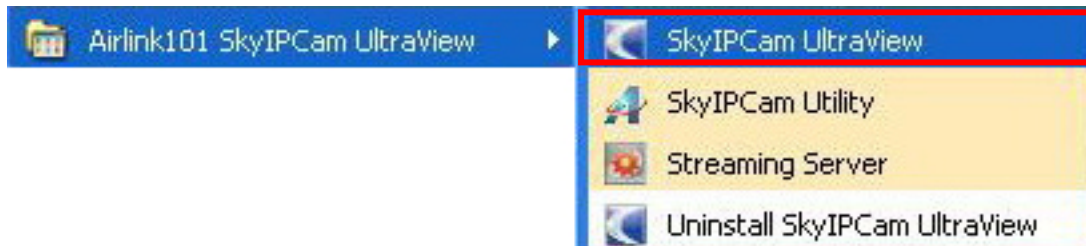

In the login window, enter the **User name/Password** and click **OK** to log in. If this is the first time you start the program and log in, use the default user name / password: *admin / admin*.



NOTE For security purpose, you are highly recommended to change the default user name and password after login. For more information, please refer to **5.6 Configuring the System > User Management** section.

5.2 Main Window and Item Feature

When you start and login to UltraView, the Main window will display as below:











The Main window provides you with the information on operating the system, as well as the control panel such as the Quick Launch buttons, and so on.

NOTE UltraView Software requires the resolution setting to be 1024 x 768 or higher. For best view of the application, you are recommended to configure the resolution setting to 1024 x 768 or higher; otherwise, it cannot be displayed on the screen when launching the program.

- 1 **Live View Window** displays the live video of the connected camera(s).
- 2 **Quick Launch Buttons** are located below the Live View Window, providing you with the following quick-launch functions:

Button	Function
	Click to select Logout or Close UltraView Software.
	Click to select Restore Recording Type , All Continuous Recording , or Stop All Recording .
	Click and then select to display the View Setting window, switch to the eMap View window, or check the Camera Status .
	Click to display the Playback window.
	Click to display the Schedule Configuration window.
	Click to configure the event settings: Event Server , Address Book , and Event Trigger .
	Click to configure Device Setting and Recording Setting .
	Click to set the Account , Language , and System Setting ; or view the Version of the program.

3 Camera View Mode buttons in this area allow you to switch the camera view mode.



Button	Function
	Display the connected camera(s) in single camera view mode.
	Display the connected camera(s) in quad view mode.
	Display the connected camera(s) in 3 x 3 grid view mode.
	Display the connected camera(s) in 13-camera view mode using a split window. The first camera is displayed as the major view.
	Display the connected camera(s) in 17-camera view mode using a split window. The first camera is displayed as the major view.
	Display the connected camera(s) in N x N grid view mode, supporting up to 36 views (up to 32 cameras).
	Display the live view of the selected camera in full screen mode.
	Automatically switch the live view of each connected cameras in single camera view mode every 30 seconds*. Click once to start and click again to stop. * The auto-switch time is set as 30 seconds by default, which can be changed by clicking the  → System Setting and then change the value from the pull-down list of the Auto Switch time interval option.



4 System Information displays the system information, including the date and time, and the available storage space of the system.

5 Live View Status provides the status of live view mode, including **Camera List** and **eMap**.

- **Camera List** displays the status of the connected cameras. If multiple cameras are connected, you can switch to the live view of each camera by simply selecting the camera from the list.
- **eMap** allows you to select the desired camera to the view from the map for viewing easily. Please note that you have to set up the eMap for monitoring in advance.

6 Camera Control Buttons provides the control buttons that allow you to control the selected camera.

Button	Function
	Talk On/Off. If the connected camera features speaker function, click to enable/disable the speaker function. This option is available only in single camera view mode.
	Listen On/Off. Click to enable/disable the microphone function of the connected camera. This option is available only in single camera view mode.
	If the connected camera features pan/tilt functions, you can use this control panel to set the preset positions (up to 8 positions). Once configured, you can move the camera lens to the desired position quickly. To set the preset positions, adjust the camera lens to the desired position using the Navigation buttons, and then select the position number (1~8) from the Set button. To move to the preset position, simply select the position

	number (1~8) from the Go button.
	Navigation Buttons (Left/Right/Up/Down/Home). If the connected camera features pan/tilt functions, the Navigation buttons allow you to move the camera lens position. Clicking the Home (center) button will move the camera lens to the assigned home position.
	The Patrol/Stop buttons are used to enable/disable the swinging function of the camera. Click Patrol to start patrolling through the preset positions once. Click Stop to stop patrolling.

5.3 Accessing the Camera

Before you can access the camera, you have to add the camera to the system.

■ Adding a Camera

1. Click the  button and select **Device Setting** to display the Device Setting window.

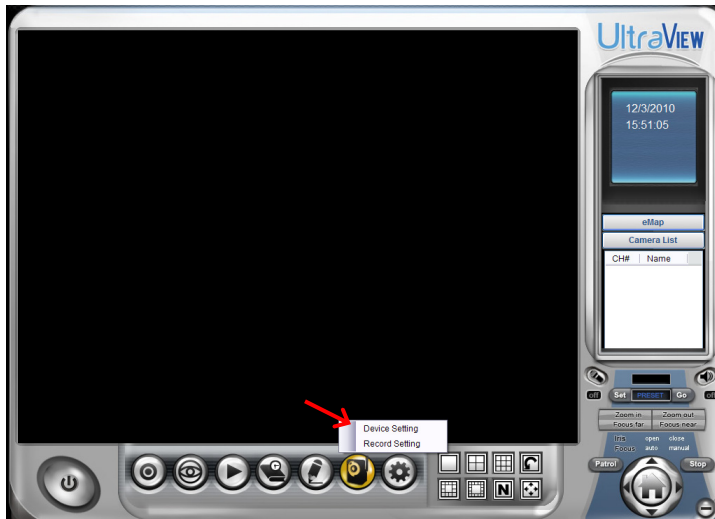

2. Click **New**.

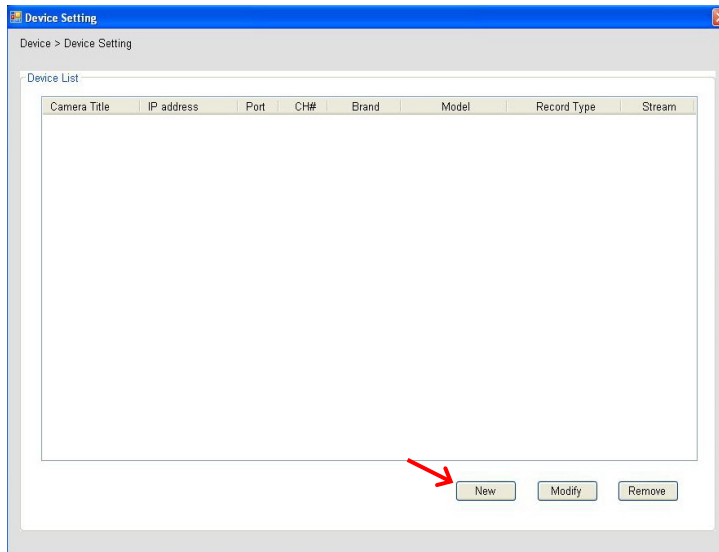

3. Click **Device Search** to search the camera(s) within your network.

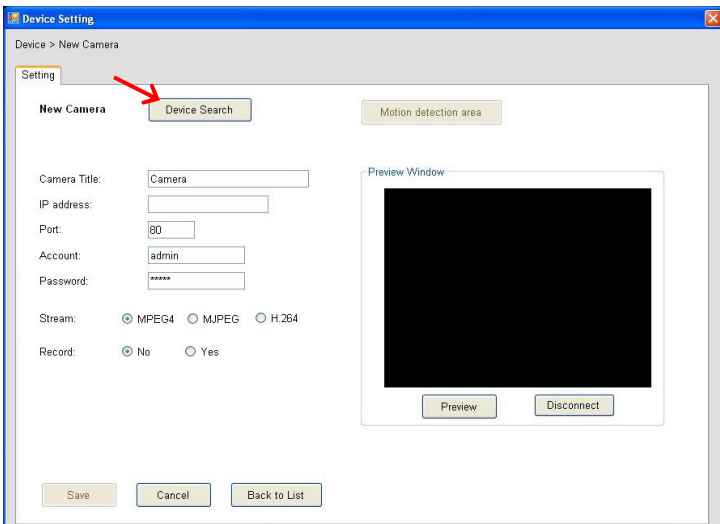

4. When search is finished, select the camera and click **Add**.

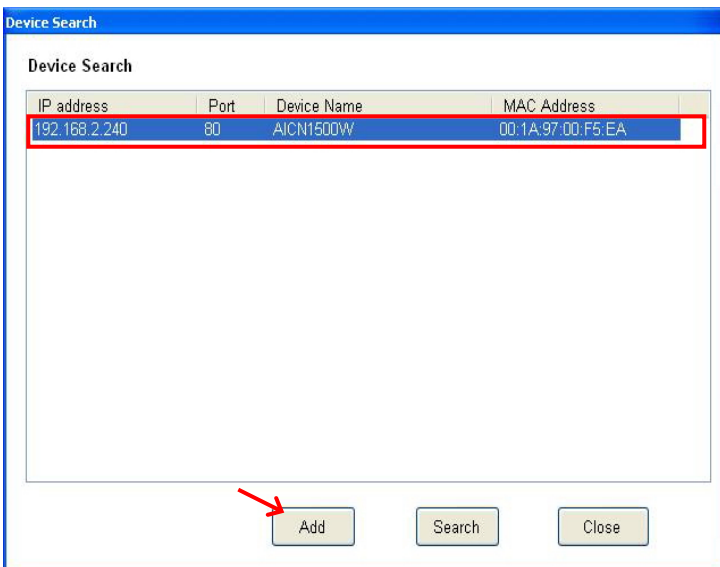

- The information of the camera will be displayed on the window. When completed, click **Preview** and then click **Save** to return to the Device Setting window. The added camera will be displayed in the Device List.

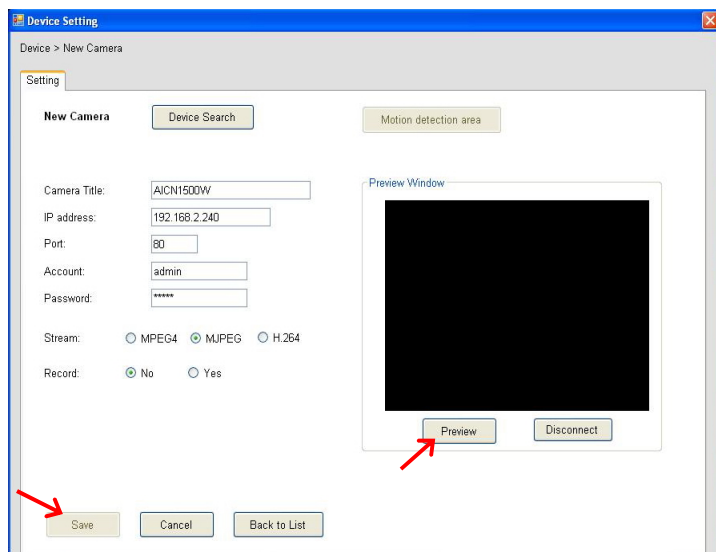

Option	Description
Camera Title	You have to assign a descriptive name for the camera.
IP Address	Display the IP address of the camera.
Port	Display the port path of the camera.
Account	Display the user name for accessing the camera.
Password	The password for accessing the camera will not be displayed.
Stream	Select the stream type as MPEG4 , MJPEG , or H.264 . (MPEG4 and H.264 is not supported by this model)
Record	Select Yes or No to set up recording function of the camera.
Preview Window	This window allows you to preview the image of the camera. Click Preview to view the image; click Disconnect to stop previewing.

TIP You cannot set the motion detection area while adding the new camera. To set the motion detection area of the camera, select the desired camera and click the Modify button on the Device Setting window. Please refer to the following section ???.

6. Close the Device Setting window and return to the Main window. The image of the camera will be displayed.



TIP When you add the camera and return to the Main window, the camera image will be displayed in full-screen mode by default. Press the ESC key on the PC keyboard to resume the Main window.

NOTE Divx/Xvid codec is required for viewing the image of camera. If the image cannot be displayed in the Live View/Preview window normally, click the following path to download and install the required component: <http://download.divx.com/divx/DivXInstaller.exe>

7. Click on the button Motion detection area to enable and set up the motion detection feature of the camera. A new window pops up with settings for motion detection. Please refer to section 4.6 Motion Detect for more details.

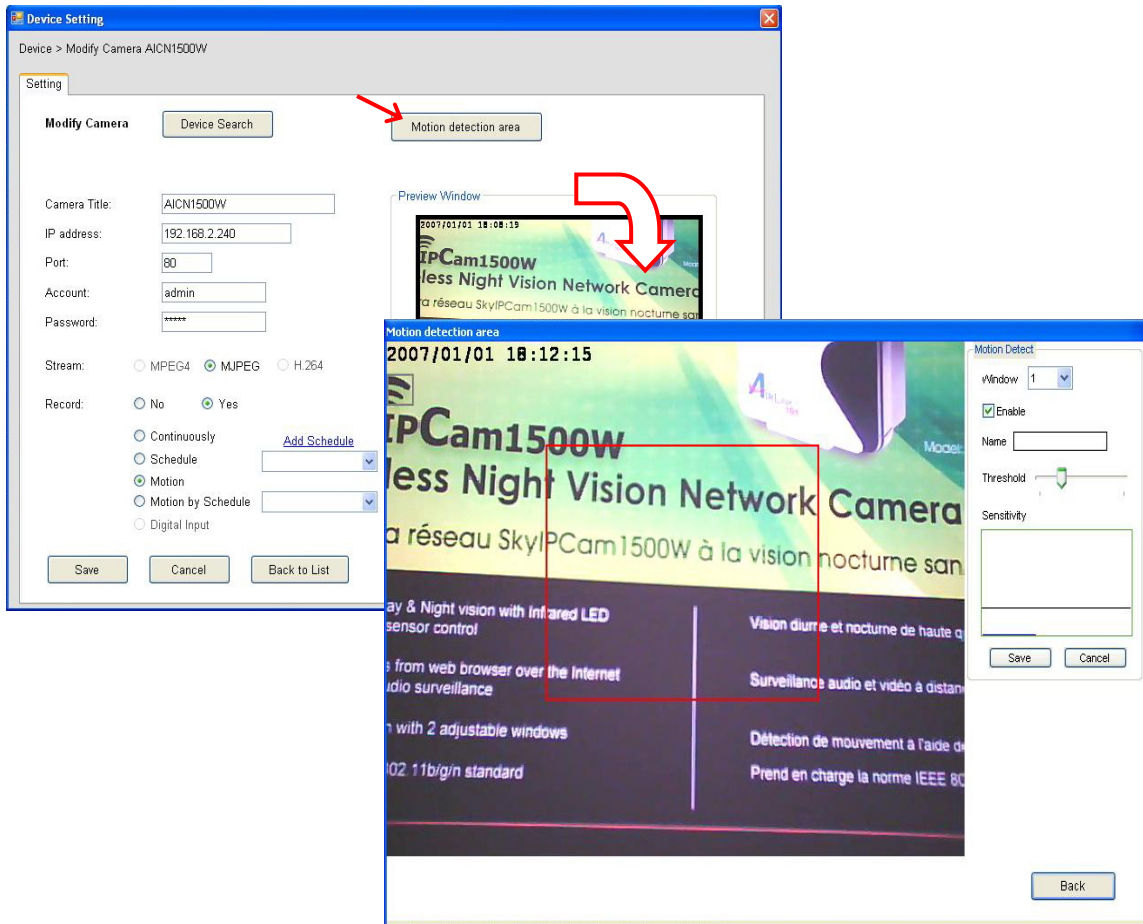

■ Editing / Deleting a Camera

Since you have added camera(s) to the system, you can select one to edit or remove.

1. On the Device Setting window, the connected camera(s) will be displayed in the Device List.

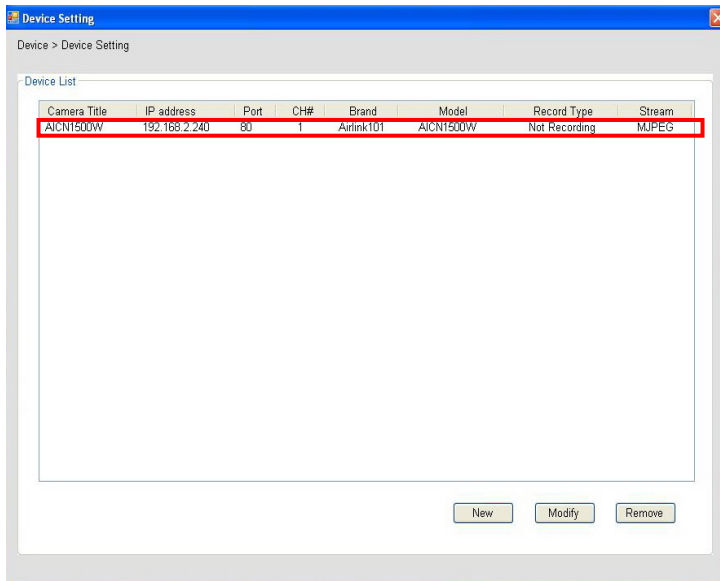

2. **To delete the camera:** select the desired one and then click **Remove**. When prompted, click **Yes** and then select **OK** to confirm deletion.

To change the configuration of the camera: select the desired one and then click **Modify**. The Modify Camera window will appear that allows you to change the configuration of the camera. When completed, click **Save** and then select **OK** to return to the Device Setting window.

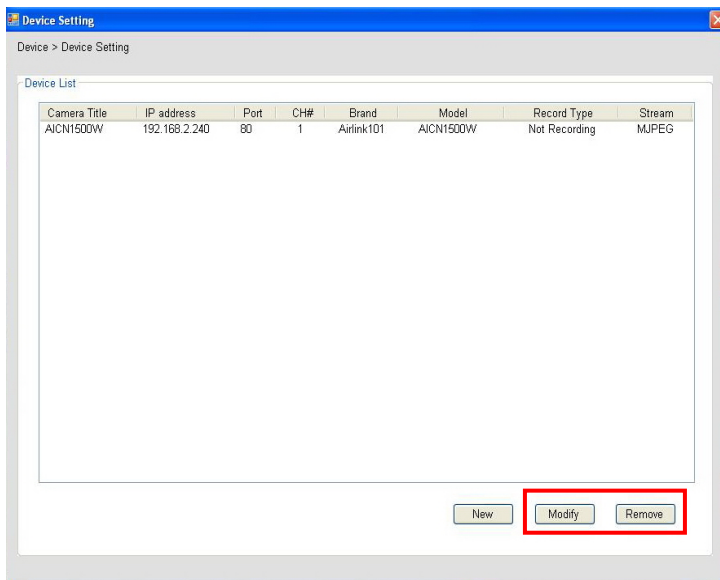

■ Viewing Image of the Camera

Since you have added camera(s) to the system, the image of the selected camera(s) will be displayed on the Live View Window automatically. You can view a maximum of 32 cameras simultaneously. Additionally, you can select one-camera or other view mode to display the video by clicking the Camera View Mode buttons.

For example, if you use only one camera, select single camera view mode (), and the Live View Window will display the view as below. You can select the other modes according to your need.

The **Information icon** () on the top-right corner of the window provides you with the options to connect/disconnect the camera, select a camera to be displayed in the window, capture a still image of the camera live video, or switch to eMap mode. Click the Information icon to pop up the shortcut menu and select the desired option.



5.4 Recording / Playing Video

■ Enabling / Disabling Recording

Press **Preview** to activate the settings. While you are adding/editing the camera, you can enable the recording function for the camera by selecting the **Record** option. Click **Save** after you finish setting.

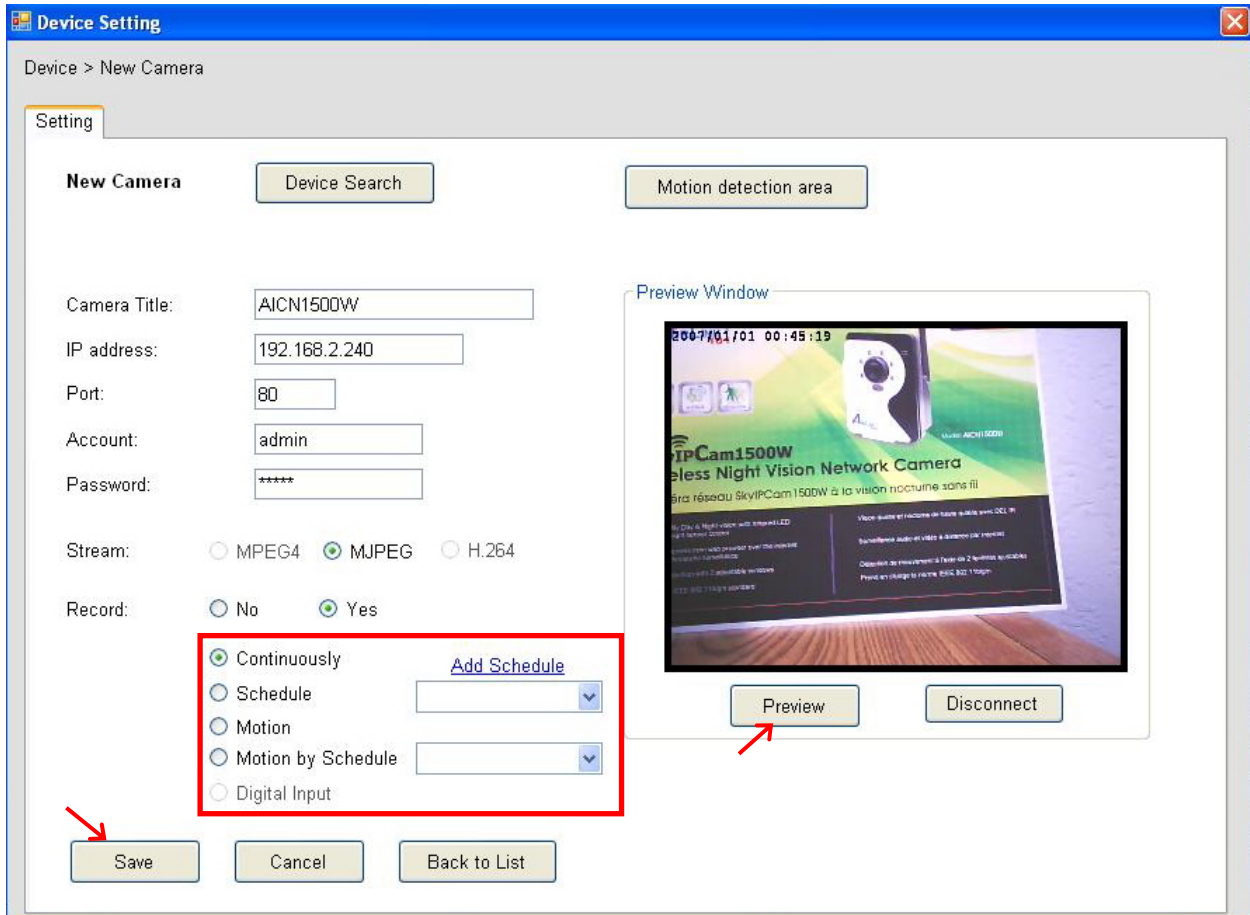

Alternatively, you can set all cameras to start/stop recording when you connect multiple cameras. Click the  button and select **All Continuous Recording** to set all cameras to start recording, or select **Stop All Recording** to stop all cameras from recording.



Since you have enabled the recording function of the camera, it will automatically start recording and save the video clips. The recording time of each file is set to 60 seconds by default.

■ Configuring the Recording Settings

The default directory for saving the recorded video files is "C:\". You can change the target folder for saving the files in the **Record Setting** option.

1. Click the  button and then select **Record Setting**.



2. To assign the target folder for saving the recorded files, click the **Browse** button next to the **Recording Path** option, and then select the desired directory. When completed, click **Save**.

To change the time of recording, select the desired time setting from the **Record File** pull-down menu.

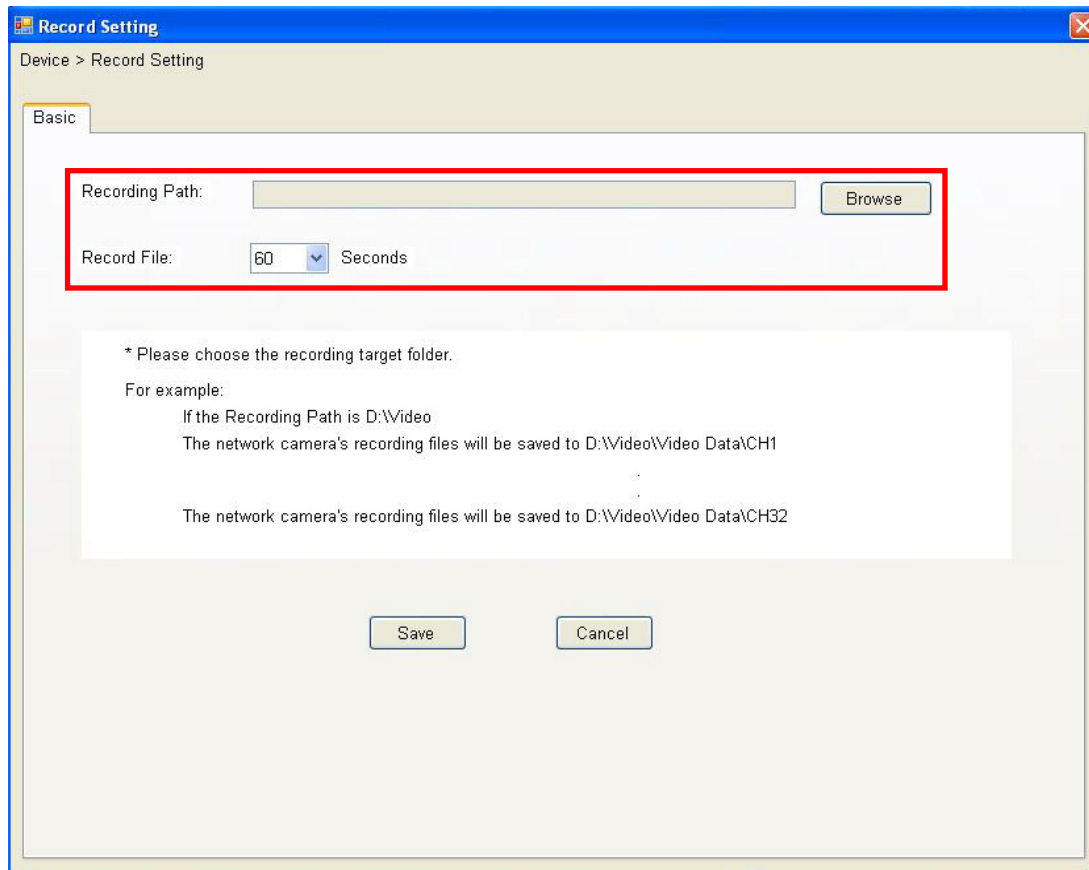

NOTE The system will automatically delete the oldest files by 10% when the size of recorded files is up to 90% of the storage space.

■ Setting up Schedule for Recording

The system features the schedule recording so that you can set up the schedule to record as you need.

Click the  button to display the Schedule Configuration window, which allows you to configure the recording schedule.

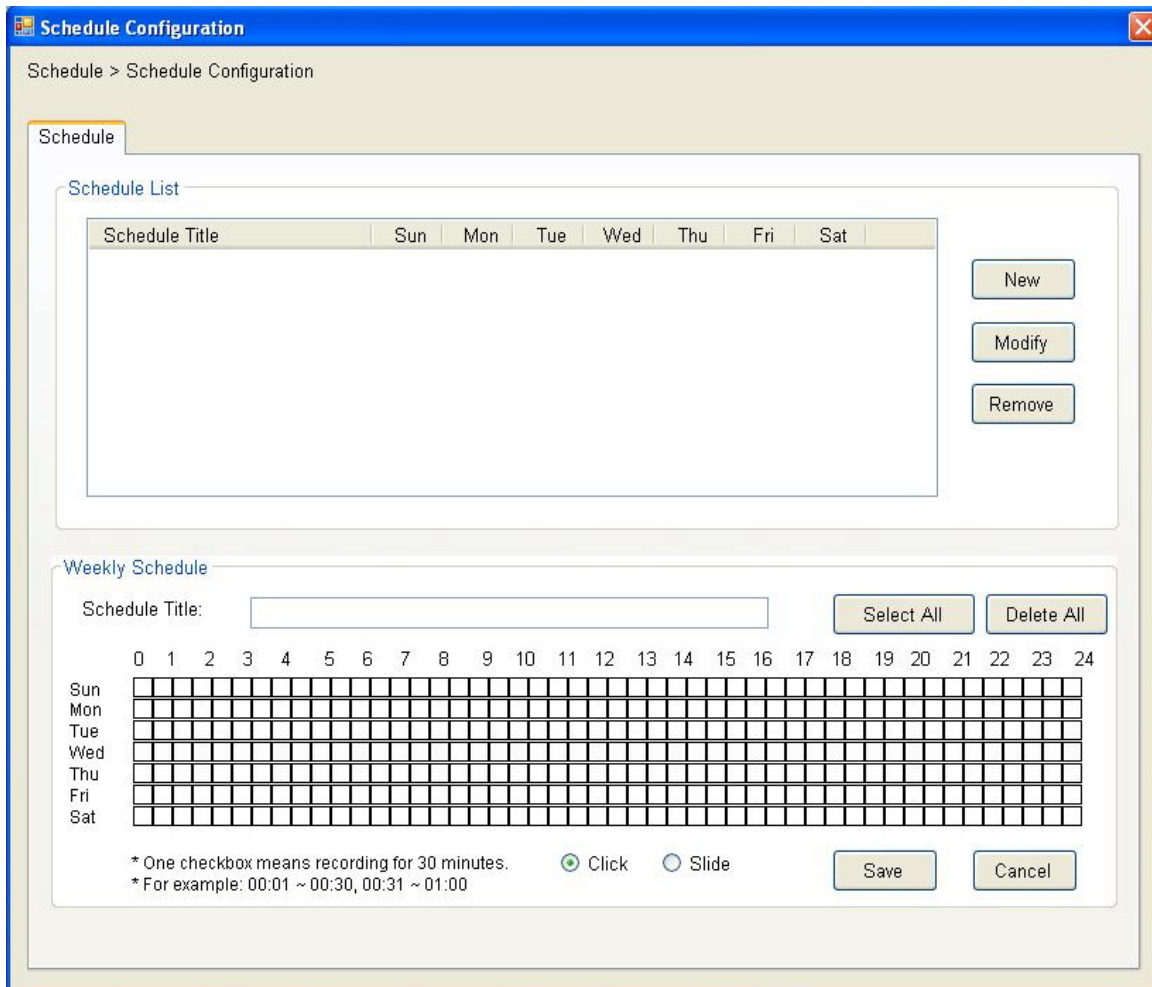

Schedule Configuration

Schedule > Schedule Configuration

Schedule

Schedule List

Schedule Title	Sun	Mon	Tue	Wed	Thu	Fri	Sat

New

Modify

Remove

Weekly Schedule

Schedule Title:

Select All Delete All

	0	1	2	3	4	5	6	7	8	9	10	11	12	13	14	15	16	17	18	19	20	21	22	23	24
Sun	<input type="checkbox"/>	<input type="checkbox"/>	<input type="checkbox"/>	<input type="checkbox"/>	<input type="checkbox"/>	<input type="checkbox"/>	<input type="checkbox"/>	<input type="checkbox"/>	<input type="checkbox"/>	<input type="checkbox"/>	<input type="checkbox"/>	<input type="checkbox"/>	<input type="checkbox"/>	<input type="checkbox"/>	<input type="checkbox"/>	<input type="checkbox"/>	<input type="checkbox"/>	<input type="checkbox"/>	<input type="checkbox"/>	<input type="checkbox"/>	<input type="checkbox"/>	<input type="checkbox"/>	<input type="checkbox"/>	<input type="checkbox"/>	<input type="checkbox"/>
Mon	<input type="checkbox"/>	<input type="checkbox"/>	<input type="checkbox"/>	<input type="checkbox"/>	<input type="checkbox"/>	<input type="checkbox"/>	<input type="checkbox"/>	<input type="checkbox"/>	<input type="checkbox"/>	<input type="checkbox"/>	<input type="checkbox"/>	<input type="checkbox"/>	<input type="checkbox"/>	<input type="checkbox"/>	<input type="checkbox"/>	<input type="checkbox"/>	<input type="checkbox"/>	<input type="checkbox"/>	<input type="checkbox"/>	<input type="checkbox"/>	<input type="checkbox"/>	<input type="checkbox"/>	<input type="checkbox"/>	<input type="checkbox"/>	<input type="checkbox"/>
Tue	<input type="checkbox"/>	<input type="checkbox"/>	<input type="checkbox"/>	<input type="checkbox"/>	<input type="checkbox"/>	<input type="checkbox"/>	<input type="checkbox"/>	<input type="checkbox"/>	<input type="checkbox"/>	<input type="checkbox"/>	<input type="checkbox"/>	<input type="checkbox"/>	<input type="checkbox"/>	<input type="checkbox"/>	<input type="checkbox"/>	<input type="checkbox"/>	<input type="checkbox"/>	<input type="checkbox"/>	<input type="checkbox"/>	<input type="checkbox"/>	<input type="checkbox"/>	<input type="checkbox"/>	<input type="checkbox"/>	<input type="checkbox"/>	<input type="checkbox"/>
Wed	<input type="checkbox"/>	<input type="checkbox"/>	<input type="checkbox"/>	<input type="checkbox"/>	<input type="checkbox"/>	<input type="checkbox"/>	<input type="checkbox"/>	<input type="checkbox"/>	<input type="checkbox"/>	<input type="checkbox"/>	<input type="checkbox"/>	<input type="checkbox"/>	<input type="checkbox"/>	<input type="checkbox"/>	<input type="checkbox"/>	<input type="checkbox"/>	<input type="checkbox"/>	<input type="checkbox"/>	<input type="checkbox"/>	<input type="checkbox"/>	<input type="checkbox"/>	<input type="checkbox"/>	<input type="checkbox"/>	<input type="checkbox"/>	<input type="checkbox"/>
Thu	<input type="checkbox"/>	<input type="checkbox"/>	<input type="checkbox"/>	<input type="checkbox"/>	<input type="checkbox"/>	<input type="checkbox"/>	<input type="checkbox"/>	<input type="checkbox"/>	<input type="checkbox"/>	<input type="checkbox"/>	<input type="checkbox"/>	<input type="checkbox"/>	<input type="checkbox"/>	<input type="checkbox"/>	<input type="checkbox"/>	<input type="checkbox"/>	<input type="checkbox"/>	<input type="checkbox"/>	<input type="checkbox"/>	<input type="checkbox"/>	<input type="checkbox"/>	<input type="checkbox"/>	<input type="checkbox"/>	<input type="checkbox"/>	<input type="checkbox"/>
Fri	<input type="checkbox"/>	<input type="checkbox"/>	<input type="checkbox"/>	<input type="checkbox"/>	<input type="checkbox"/>	<input type="checkbox"/>	<input type="checkbox"/>	<input type="checkbox"/>	<input type="checkbox"/>	<input type="checkbox"/>	<input type="checkbox"/>	<input type="checkbox"/>	<input type="checkbox"/>	<input type="checkbox"/>	<input type="checkbox"/>	<input type="checkbox"/>	<input type="checkbox"/>	<input type="checkbox"/>	<input type="checkbox"/>	<input type="checkbox"/>	<input type="checkbox"/>	<input type="checkbox"/>	<input type="checkbox"/>	<input type="checkbox"/>	<input type="checkbox"/>
Sat	<input type="checkbox"/>	<input type="checkbox"/>	<input type="checkbox"/>	<input type="checkbox"/>	<input type="checkbox"/>	<input type="checkbox"/>	<input type="checkbox"/>	<input type="checkbox"/>	<input type="checkbox"/>	<input type="checkbox"/>	<input type="checkbox"/>	<input type="checkbox"/>	<input type="checkbox"/>	<input type="checkbox"/>	<input type="checkbox"/>	<input type="checkbox"/>	<input type="checkbox"/>	<input type="checkbox"/>	<input type="checkbox"/>	<input type="checkbox"/>	<input type="checkbox"/>	<input type="checkbox"/>	<input type="checkbox"/>	<input type="checkbox"/>	<input type="checkbox"/>

* One checkbox means recording for 30 minutes. Click Slide

* For example: 00:01 ~ 00:30, 00:31 ~ 01:00

Save Cancel

1. Click **New**, and then enter the Schedule Title.
2. Select the checkboxes below the Schedule Title to set the time to record video. One checkbox stands for 30 minutes of recording time. You can choose to assign the single checkbox repeatedly by using Click, or assign a period of time by using Slide. Alternately, you can quickly select/cancel the checkboxes by clicking **Select All** or **Delete All**.
3. When completed, click **Save**. The schedule profile will be added to the Schedule List.
4. To edit the schedule, select the desired schedule profile from the list, and then change the settings by using the **Modify** or **Remove** button.

■ Playback the Recording Files

NOTE Divx/Xvid codec is required for the system to play the video files. If the video clips cannot be displayed in the Playback window normally, click the following path to download and install the required component: <http://download.divx.com/divx/DivXInstaller.exe>

1. Click the  button to display the Playback window.



2. On the Playback window, set the conditions for search, such as selecting the camera and setting the begin/end date and time. When the search condition has been set, click **Search**.

The search result will be displayed in the Record File list.

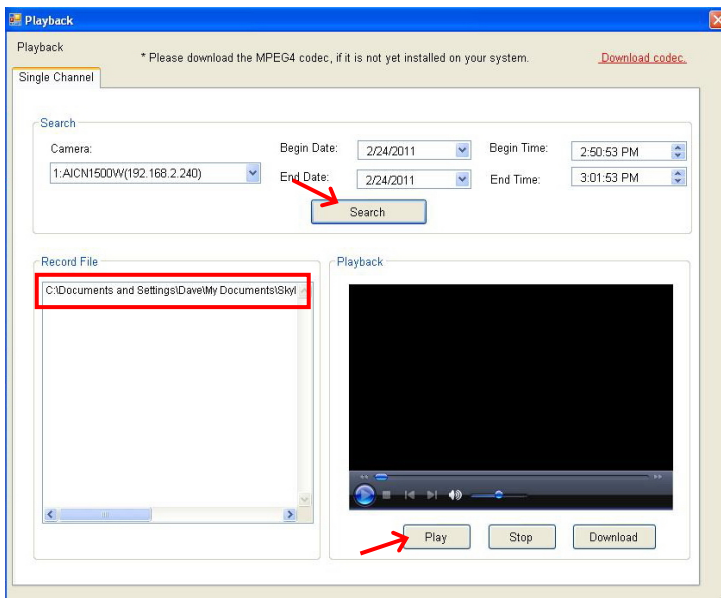

3. To playback the video clip, select the desired file and click **Play**.

5.5 Configuring the eMap View Setting

Click the  button and select **View Setting** to configure the camera view setting of eMap mode.

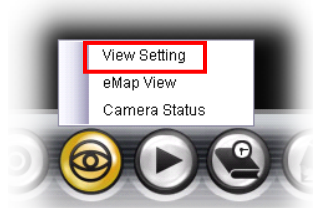

eMap refers to the geography and device scope of the UltraView Software, which visually presents the devices in your security system. It uses a background of the area (e.g. a picture or a map) as the interface for monitoring.

1. In the **View Setting** window, click **New**.

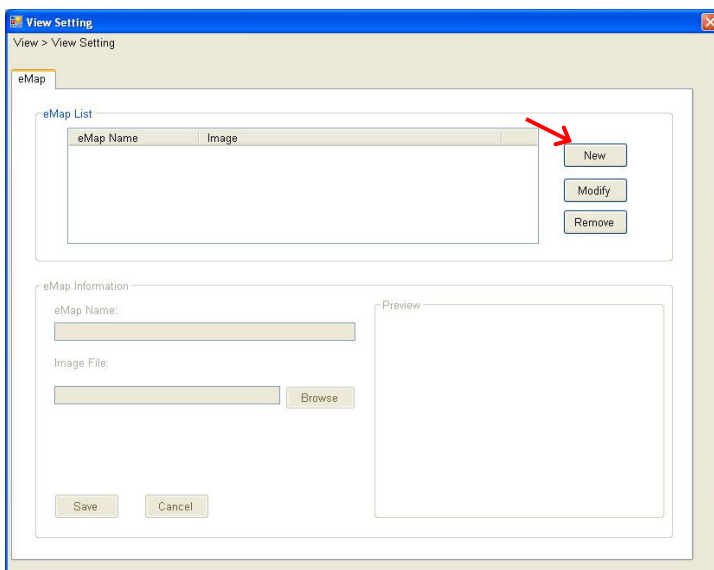

2. Enter the **eMap Name**.

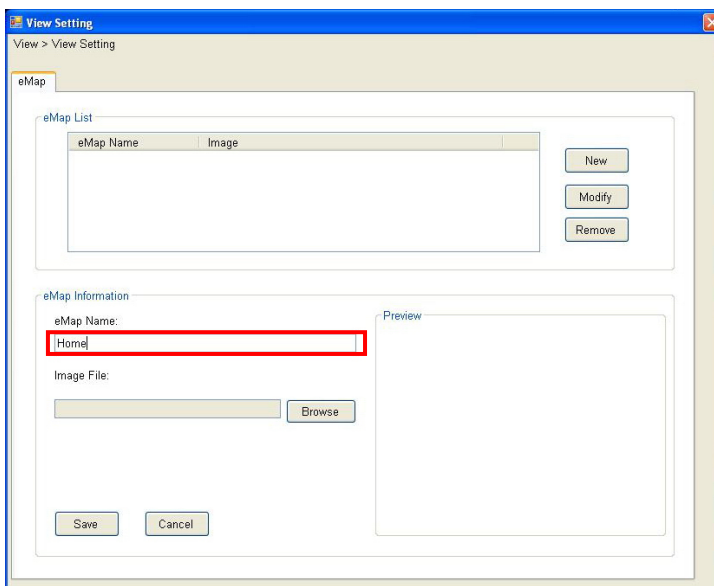

3. Click **Browse** to select a **Picture File** from your computer. The selected picture will be displayed in the Preview window.

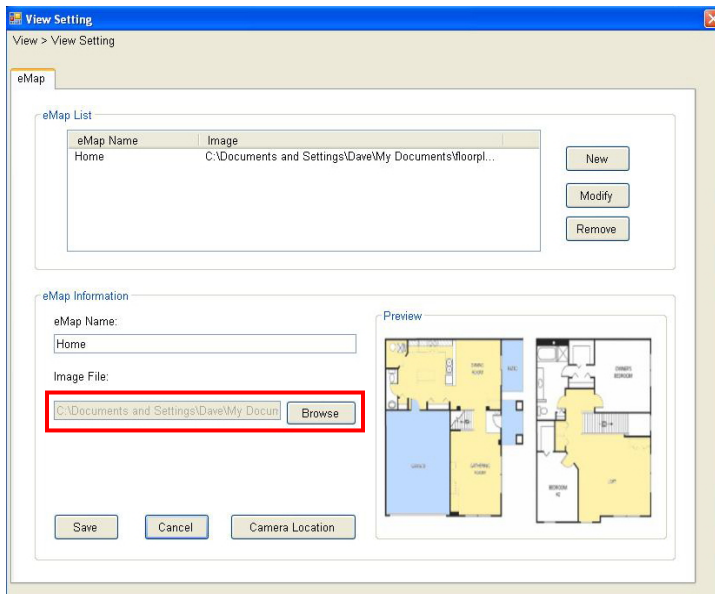

Click **Save** after you complete the settings.

4. On the following window, you can assign the camera position in the eMap.

Click the **Camera Location** button to display the Edit window. Select the camera from the Camera List, and then move the mouse to the desired position of the map and click. The camera icon will be displayed on selected location of the map.

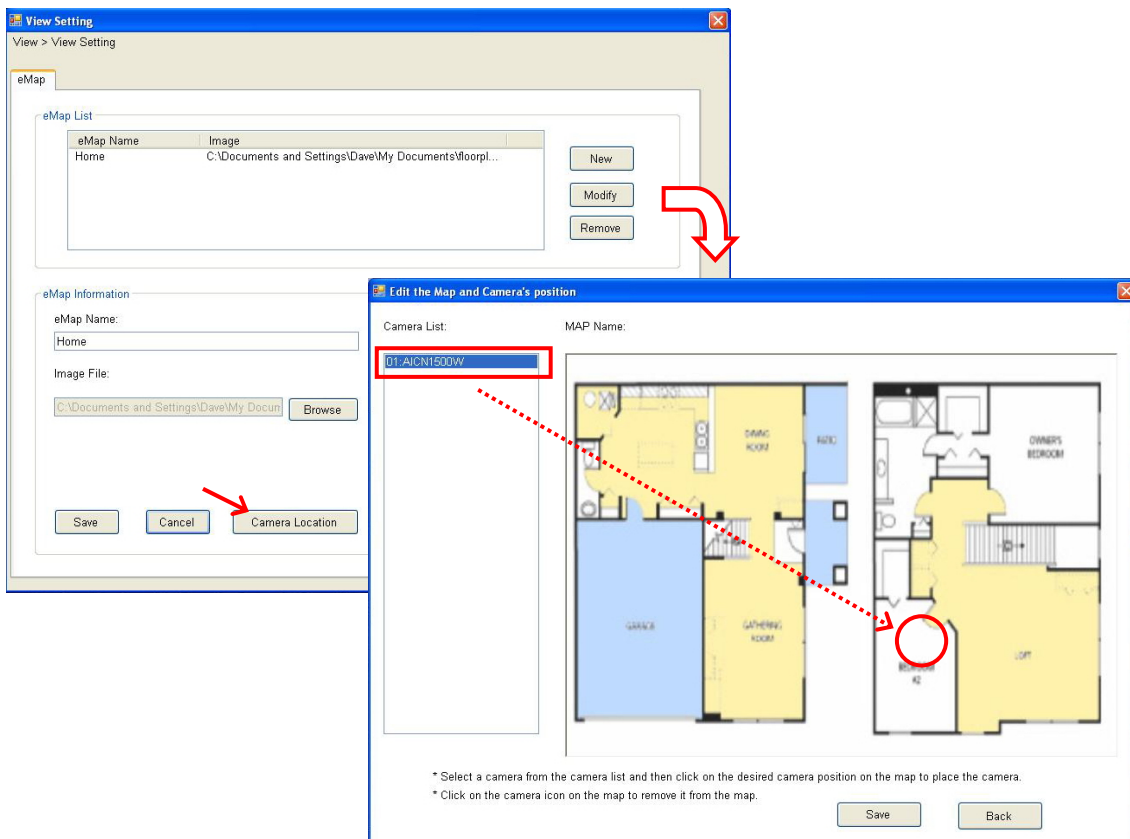

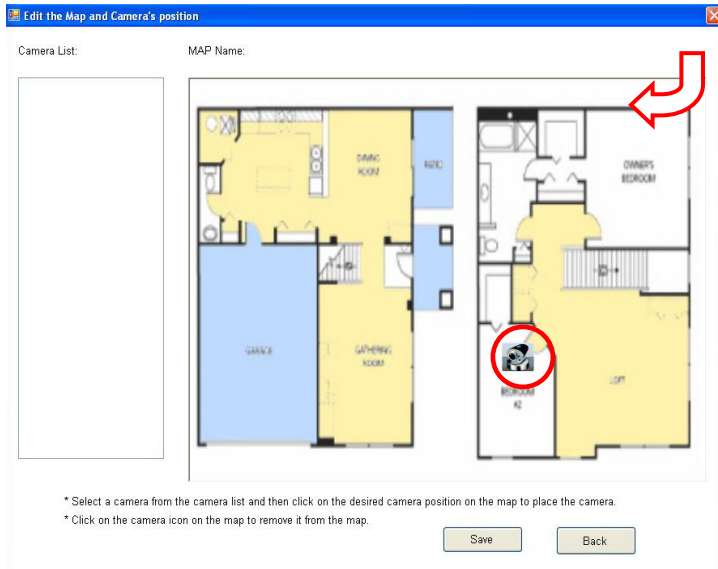

5. When completed, click **Save**. Click **Back** to go back to the Main window.

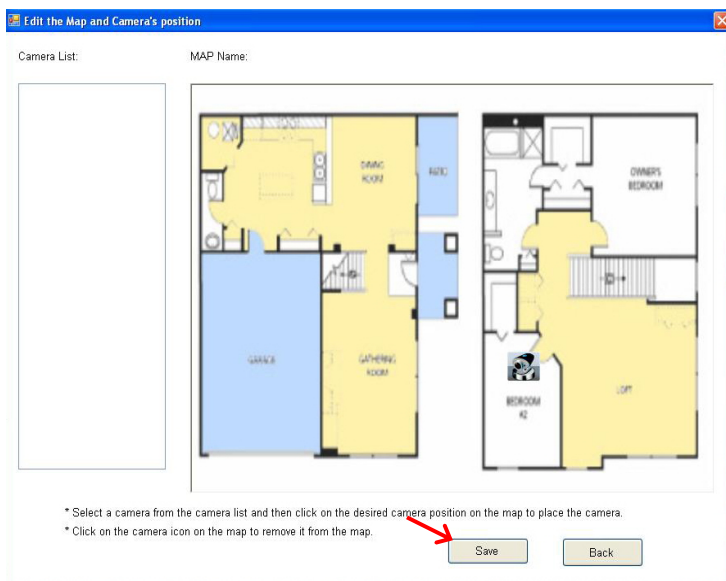

6. To view from eMap:

a. Click the  button and select **eMap View**.



- b. Select the map from the eMap Name list.

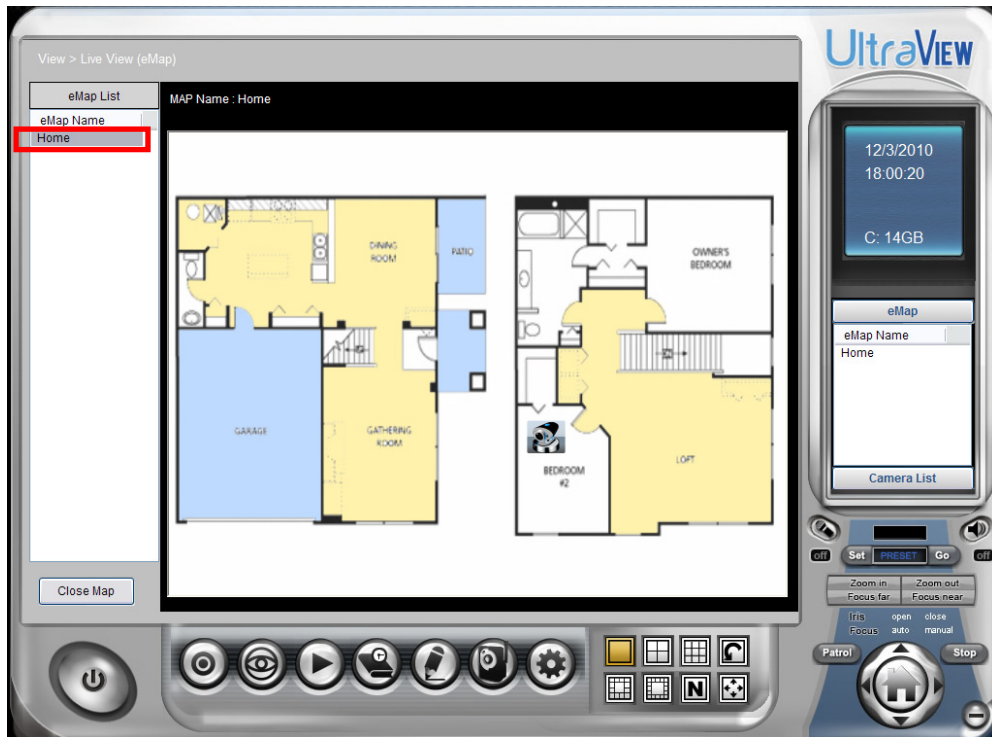

- c. Click the camera icon, the camera window will then pop up to display the image of that location.

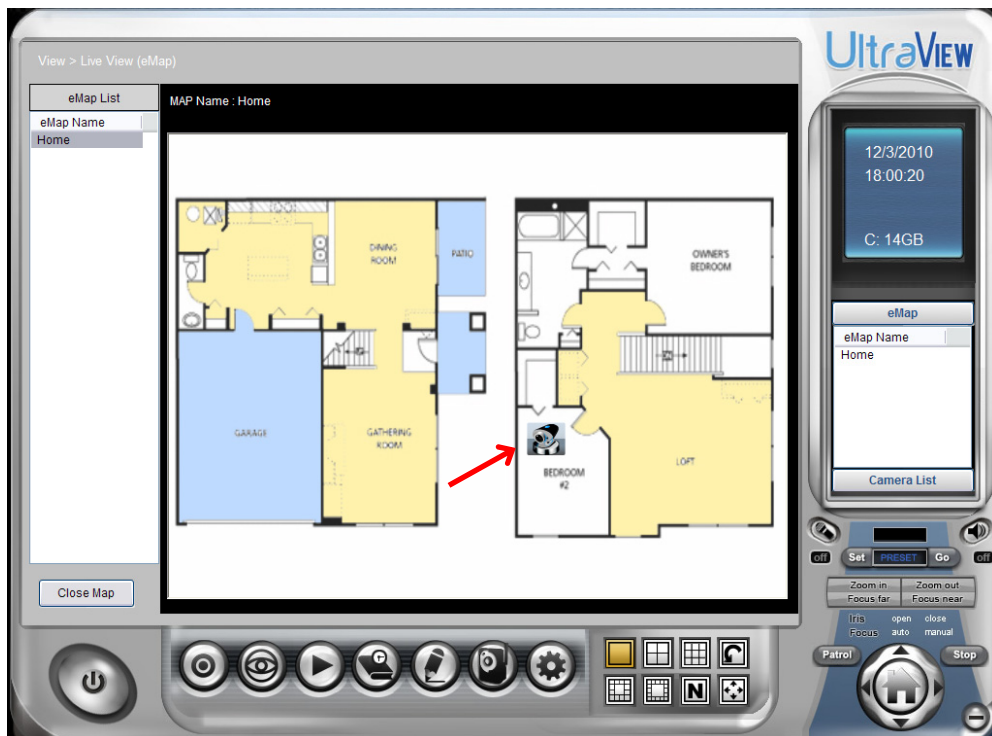

7. To view Camera Status:

Click the  button and select **Camera Status**. It shows the camera status as below.

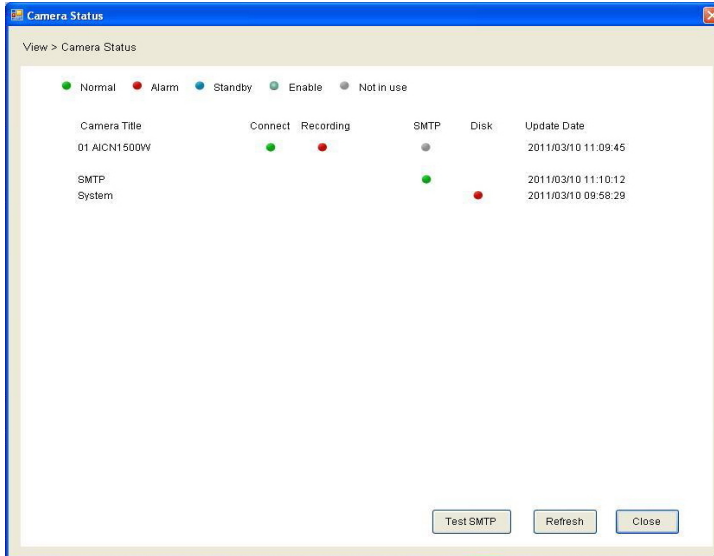

■ Editing / Deleting the eMap

1. Click the  button and select **View Setting**.
2. **To edit the eMap:** In the eMap List, select the desired map and click **Modify**.
The map's information will be displayed, where you can change the map's information and then click **Save** when completed.
3. **To delete the eMap:** In the eMap List, select the desired one and click **Remove**.
The selected map will be removed from the list.

5.6 Configuring the System

1. User management:

Click the  button and select **Account** to change the administrator password for the UltraView software.

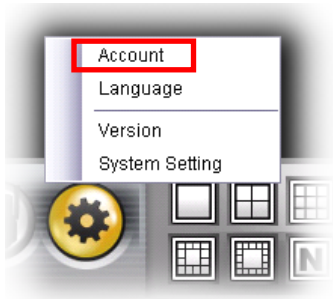

Enter the **Current password**, and then enter the new password twice (in the **Type new password** and **Retype password** boxes). When completed, click **Save**.

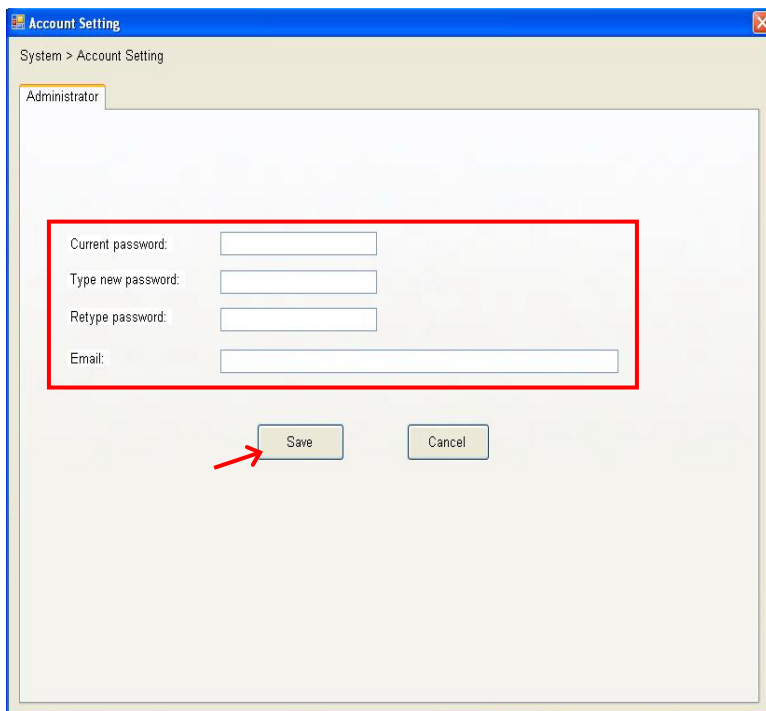
A screenshot of the 'Account Setting' dialog box. The dialog has a title bar with 'Account Setting' and a close button. Below the title bar, it says 'System > Account Setting'. There is a tab labeled 'Administrator'. The main area contains four input fields: 'Current password:', 'Type new password:', 'Retype password:', and 'Email:'. A red rectangular box highlights these four input fields. At the bottom of the dialog, there are two buttons: 'Save' and 'Cancel'. A red arrow points to the 'Save' button.

2. To change the System Language:

Click the  button and select **language** to change the displayed system language. In the Language screen, select the preferred language (**English**, **Traditional Chinese**, or **Simplified Chinese**) and click **Save**.

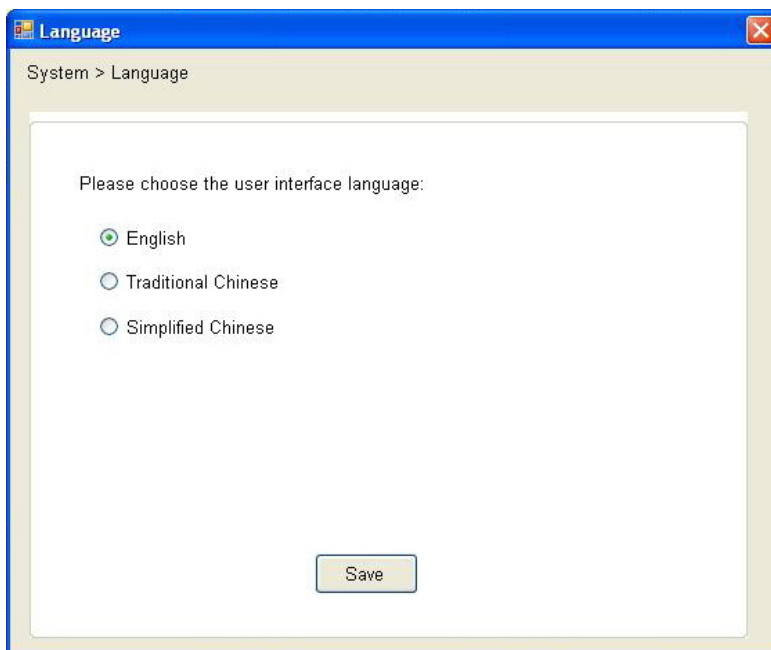
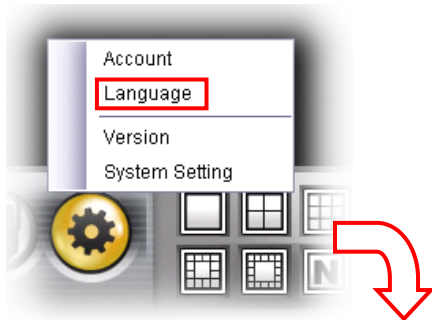

3. To check the version number:

Click the  button and select **Version** to display UltraView software version number.

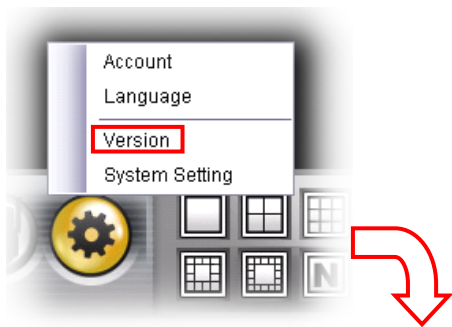

4. System Setting:

Click the  button and select **System Setting** to set the Auto Scan time interval.

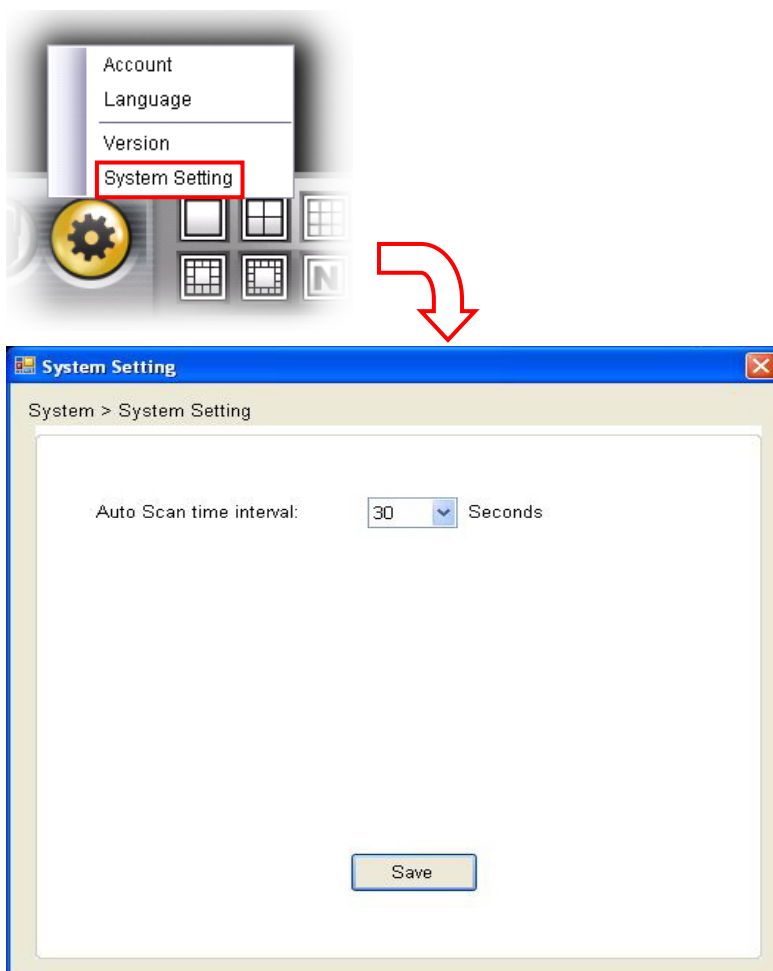

5.7 Event Configuration

■ Setting up Event Server

Click the  button and select **Event Server** to configure the SMTP server, so that you can send emails that include still images as notification.

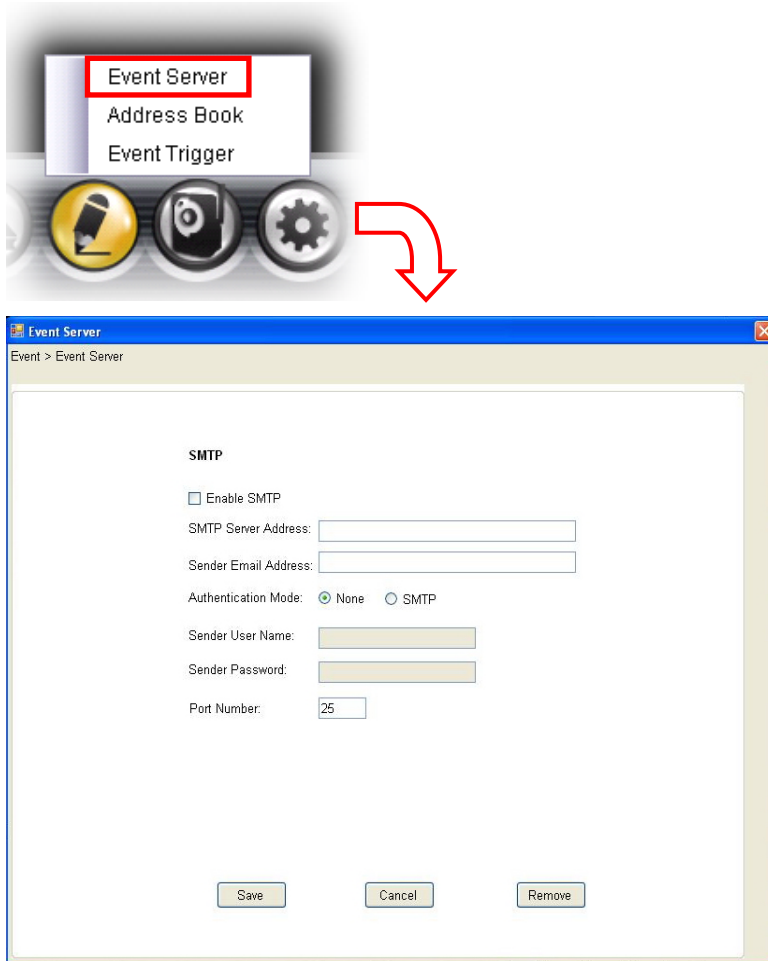

Select the **Enable SMTP** option to start the email service of the system. When you enable the service, you have to complete the following settings.

- **SMTP Server Address:** Enter the mail server address. For example, mymail.com.
- **Sender Email Address:** Enter the email address of the user who will send the email. For example, John@mymail.com.
- **Authentication Mode:** Select **None** or **SMTP** according to the mail server configuration.
- **Sender User Name:** Enter the user name to login the mail server.
- **Sender Password:** Enter the password to login the mail server.
- **Port Number:** Enter the port number used for the email server.

TIP The status of Event Service is indicated by the  icon in the system bar.

■ Sending Email Notification



Click the  button and select **Address Book** to assign the user to the Address Book of the camera. The user will receive a real-time notification from the system while triggering out.

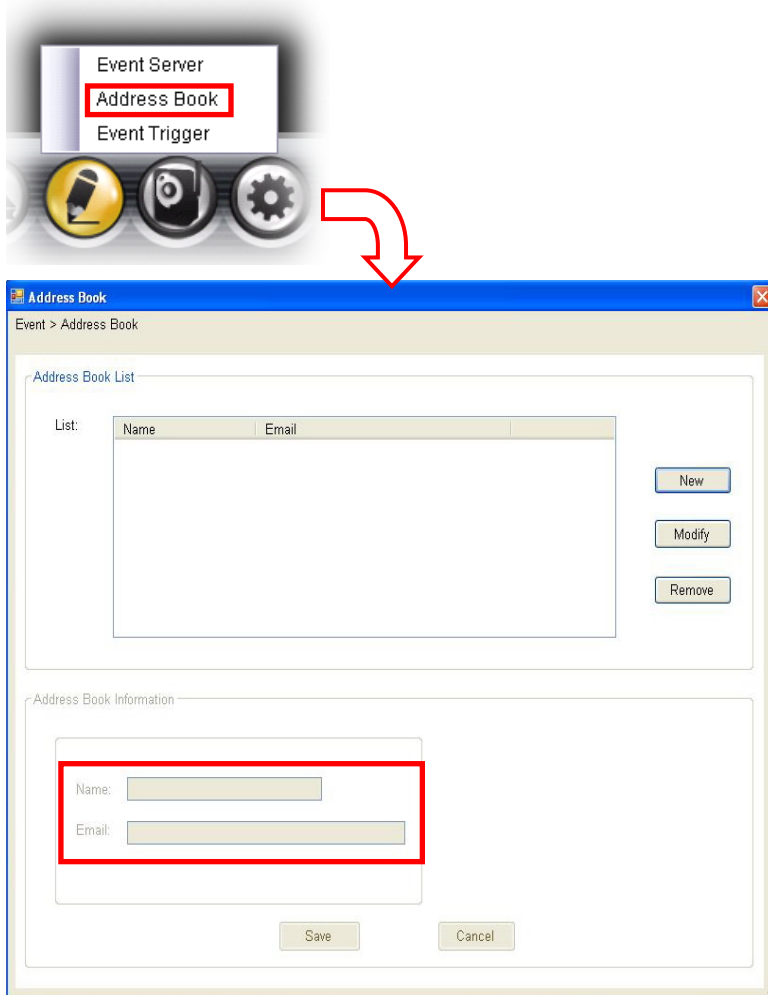

1. On the Address Book window, click **New**.
2. In the Address Book Information field, enter the **Name** and **Email** of receiver.
3. When completed, click **Save**. The receiver will be displayed in the Address Book List.
4. **To edit receiver:** In the Address Book List, select the desired receiver and click **Modify**. The receiver's information will be displayed, where you can change the receiver's information and then click **Save** when completed.
5. **To delete receiver:** In the Address Book List, select the desired receiver and click **Remove**. The selected user will be removed from the list.

■ Configuring Event Trigger



Click the  button and select **Event Trigger** to configure the trigger out function of the camera.



Camera List

C...	Name	IP address	Port
1	AICN150...	192.168.2.240	80

Trigger Setting

SMTP [Add Address Book](#)

Address Book List

Name	Email
------	-------

Subject:

Message:

Play Sound

eMap Popup

1. On the Event Trigger window, select the desired camera from the Camera List.
2. Select one or all of the following:
 - **SMTP:** Select this option and enter the Subject and Message, the system will send an email message to the selected user(s) in the Address Book List.
 - **Play Sound:** Select this option select a sound file from the computer, so that the system will alarm by the sound when triggered.
 - **eMap Popup:** Select this option and select the eMap profile from the pull-down menu. The camera view of the eMap will be displayed when triggered.

5.8 Terminating Operation

When you have finished operating, click the  button and select **Logout** to log out the system or **Close** to exit the program.

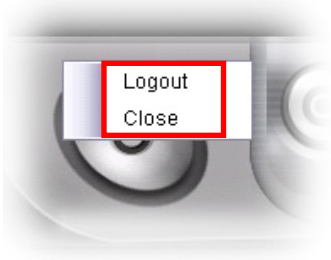

Appendix

A.1 Specification

- **Image Sensor**
 - Sensor** 1/4" color CMOS
 - Resolution** 640x480
- **Video**
 - Compression** MJPEG
 - Video resolution** VGA/QVGA/QQVGA; 30fps max.
- **Audio**
 - Input** Built-in MIC
- **User Interface**
 - LAN** One RJ-45 port
 - Antenna** One external antenna
 - Reset** One reset button
 - WPS** One WPS button (EZ Setup Button)
 - LEDs** Power (amber); Link (green)
- **System Hardware**
 - Processor** ARM9 base
 - RAM** 32MB SDRAM
 - ROM** 4MB NOR Flash
 - Power** DC 5V/2.5A
- **Communication**
 - LAN** 10/100Mbps Fast Ethernet, auto-sensed, Auto-MDIX
 - WLAN** IEEE 802.11b/g/n, data rate of up to 150Mbps*
 - Protocol support** TCP/IP, UDP, ICMP, DHCP, NTP, DNS, DDNS, SMTP, FTP, HTTP, PPPoE, UPnP
- **Software**
 - OS Support** Windows 7/Vista/XP
 - Browser** Internet Explorer 6.0 or above
Apple Safari 2 or above
Mozilla Firefox 2.00 or above
 - Software** SkyIPCam UltraView for playback/recording/configuration features
- **Operating Environment**
 - Temperature** Operation: 0°C ~ 45°C
Storage: -15°C ~ 60°C
 - Humidity** Operation: 20% ~ 85% non-condensing
Storage: 0% ~ 90% non-condensing
- **EMI**
 - FCC Class B, CE Class B

A.2 Glossary of Terms

NUMBERS

10BASE-T

10BASE-T is Ethernet over UTP Category III, IV, or V unshielded twisted-pair media.

100BASE-TX

The two-pair twisted-media implementation of 100BASE-T is called 100BASE-TX.

A

ADPCM

Adaptive Differential Pulse Code Modulation, a new technology improved from PCM, which encodes analog sounds to digital form.

AMR

AMR (Adaptive Multi-Rate) is an audio data compression scheme optimized for speech coding, which is adopted as the standard speech codec by 3GPP.

Applet

Applets are small Java programs that can be embedded in an HTML page. The rule at the moment is that an applet can only make an Internet connection to the computer form that the applet was sent.

ASCII

American Standard Code For Information Interchange, it is the standard method for encoding characters as 8-bit sequences of binary numbers, allowing a maximum of 256 characters.

ARP

Address Resolution Protocol. ARP is a protocol that resides at the TCP/IP Internet layer that delivers data on the same network by translating an IP address to a physical address.

AVI

Audio Video Interleave, it is a Windows platform audio and video file type, a common format for small movies and videos.

B

BOOTP

Bootstrap Protocol is an Internet protocol that can automatically configure a network device in a diskless workstation to give its own IP address.

C

Communication

Communication has four components: sender, receiver, message, and medium. In networks, devices and application tasks and processes communicate messages to each other over media. They represent the sender and receivers. The data they send is the message. The cabling or transmission method they use is the medium.

Connection

In networking, two devices establish a connection to communicate with each other.

D

DHCP

Developed by Microsoft, DHCP (Dynamic Host Configuration Protocol) is a protocol for assigning dynamic IP addresses to devices on a network. With dynamic addressing, a device can have a different IP address every time it connects to the network. In some systems, the device's IP address can even change while it is still connected. It also supports a mix of static and dynamic IP addresses. This simplifies the task for network administrators because the software keeps track of IP addresses rather than requiring an administrator to manage the task. A new computer can be added to a network without the hassle of manually assigning it a unique IP address. DHCP allows the specification for the service provided by a router, gateway, or other network device that automatically assigns an IP address to any device that requests one.

DNS

Domain Name System is an Internet service that translates domain names into IP addresses. Since domain names are alphabetic, they're easier to remember. The Internet however, is really based on IP addresses every time you use a domain name the DNS will translate the name into the corresponding IP address. For example, the domain name *www.network_camera.com* might translate to *192.167.222.8*.

E

Enterprise network

An enterprise network consists of collections of networks connected to each other over a geographically dispersed area. The enterprise network serves the needs of a widely

	distributed company and operates the company's mission-critical applications.
Ethernet	The most popular LAN communication technology. There are a variety of types of Ethernet, including 10Mbps (traditional Ethernet), 100Mbps (Fast Ethernet), and 1,000Mbps (Gigabit Ethernet). Most Ethernet networks use Category 5 cabling to carry information, in the form of electrical signals, between devices. Ethernet is an implementation of CSMA/CD that operates in a bus or star topology.
<u>F</u>	
Fast Ethernet	Fast Ethernet, also called 100BASE-T, operates at 10 or 100Mbps per second over UTP, STP, or fiber-optic media.
Firewall	Firewall is considered the first line of defense in protecting private information. For better security, data can be encrypted. A system designed to prevent unauthorized access to or from a private network. Firewalls are frequently used to prevent unauthorized Internet users from accessing private networks connected to the Internet, especially Intranets all messages entering or leaving the intranet pass through the firewall, which examines each message and blocks those that do not meet the specified security criteria.
<u>G</u>	
Gateway	A gateway links computers that use different data formats together.
Group	Groups consist of several user machines that have similar characteristics such as being in the same department.
<u>H</u>	
HEX	Short for hexadecimal refers to the base-16 number system, which consists of 16 unique symbols: the numbers 0 to 9 and the letters A to F. For example, the decimal number 15 is represented as F in the hexadecimal numbering system. The hexadecimal system is useful because it can represent every byte (8 bits) as two consecutive hexadecimal digits. It is easier for humans to read hexadecimal numbers than binary numbers.
<u>I</u>	
Intranet	This is a private network, inside an organization or company that uses the same software you will find on the public Internet. The only difference is that an Intranet is used for internal usage only.
Internet	The Internet is a globally linked system of computers that are logically connected based on the Internet Protocol (IP). The Internet provides different ways to access private and public information worldwide.
Internet address	To participate in Internet communications and on Internet Protocol-based networks, a node must have an Internet address that identifies it to the other nodes. All Internet addresses are IP addresses
IP	Internet Protocol is the standard that describes the layout of the basic unit of information on the Internet (the <i>packet</i>) and also details the numerical addressing format used to route the information. Your Internet service provider controls the IP address of any device it connects to the Internet. The IP addresses in your network must conform to IP addressing rules. In smaller LANs, most people will allow the DHCP function of a router or gateway to assign the IP addresses on internal networks.
IP address	IP address is a 32-binary digit number that identifies each sender or receiver of information that is sent in packets across the Internet. For example 80.80.80.69 is an IP address. When you "call" that number, using any connection methods, you get connected to the computer that "owns" that IP address.
ISP	ISP (Internet Service Provider) is a company that maintains a network that is linked to the Internet by way of a dedicated communication line. An ISP offers the use of its dedicated communication lines to companies or individuals who can't afford the high monthly cost for a direct connection.

J

JAVA

Java is a programming language that is specially designed for writing programs that can be safely downloaded to your computer through the Internet without the fear of viruses. It is an object-oriented multi-thread programming best for creating applets and applications for the Internet, Intranet and other complex, distributed network.

L

LAN

Local Area Network a computer network that spans a relatively small area sharing common resources. Most LANs are confined to a single building or group of buildings.

M

MJPEG

MJPEG (Motion JPEG) composes a moving image by storing each frame of a moving picture sequence in JPEG compression, and then decompressing and displaying each frame at rapid speed to show the moving picture.

MPEG4

MPEG4 is designed to enable transmission and reception of high-quality audio and video over the Internet and next-generation mobile telephones.

N

NAT

Network Address Translator generally applied by a router that makes many different IP addresses on an internal network appear to the Internet as a single address. For routing messages properly within your network, each device requires a unique IP address. But the addresses may not be valid outside your network. NAT solves the problem. When devices within your network request information from the Internet, the requests are forwarded to the Internet under the router's IP address. NAT distributes the responses to the proper IP addresses within your network.

Network

A network consists of a collection of two or more devices, people, or components that communicate with each other over physical or virtual media. The most common types of network are:

LAN – (local area network): Computers are in close distance to one another. They are usually in the same office space, room, or building.

WAN – (wide area network): The computers are in different geographic locations and are connected by telephone lines or radio waves.

NWay Protocol

A network protocol that can automatically negotiate the highest possible transmission speed between two devices.

P

PCM

PCM (Pulse Code Modulation) is a technique for converting analog audio signals into digital form for transmission.

PING

Packet Internet Groper, a utility used to determine whether a specific IP address is accessible. It functions by sending a packet to the specified address and waits for a reply. It is primarily used to troubleshoot Internet connections.

PPPoE

Point-to-Point Protocol over Ethernet. PPPoE is a specification for connecting the users on an Ethernet to the Internet through a common broadband medium, such as DSL or cable modem. All the users over the Ethernet share a common connection.

Protocol

Communication on the network is governed by sets of rules called protocols. Protocols provide the guidelines devices use to communicate with each other, and thus they have different functions. Some protocols are responsible for formatting and presenting and presenting data that will be transferred from file server memory to the file server's network adapter Others are responsible for filtering information between networks and forwarding data to its destination. Still other protocols dictate how data is transferred across the medium, and how servers respond to workstation requests and vice versa. Common network protocols responsible for the presentation and formatting of data for a network operating system are the Internetwork Packet Exchange (IPX) protocol or the Internet Protocol (IP). Protocols that dictate the format of data for transfers on the medium include token-passing and Carrier Sense Multiple Access with Collision

Detection (CSMA/CD), implemented as token-ring, ARCNET, FDDI, or Ethernet. The Router Information Protocol (RIP), a part of the Transmission Control Protocol/Internet Protocol (TCP/IP) suite, forwards packets from one network to another using the same network protocol.

R

RJ-45

RJ-45 connector is used for Ethernet cable connections.

Router

A router is the network software or hardware entity charged with routing packets between networks.

RTP

RTP (Real-time Transport Protocol) is a data transfer protocol defined to deliver **live media** to the clients at the same time, which defines the transmission of video and audio files in real time for Internet applications.

RTSP

RTSP (Real-time Streaming Protocol) is the standard used to transmit **stored media** to the client(s) at the same time, which provides client controls for random access to the content stream.

S

Server

It is a simple computer that provides resources, such as files or other information.

SIP

SIP (Session Initiated Protocol) is a standard protocol that delivers the real-time communication for Voice over IP (VoIP), which establishes sessions for features such as audio and video conferencing.

SMTP

The Simple Mail Transfer Protocol is used for Internet mail.

SNMP

Simple Network Management Protocol. SNMP was designed to provide a common foundation for managing network devices.

Station

In LANs, a station consists of a device that can communicate data on the network. In FDDI, a station includes both physical nodes and addressable logical devices. Workstations, single-attach stations, dual-attach stations, and concentrators are FDDI stations.

Subnet mask

In TCP/IP, the bits used to create the subnet are called the subnet mask.

T

(TCP/IP)

Transmission Control Protocol/Internet Protocol is a widely used transport protocol that connects diverse computers of various transmission methods. It was developed by the Department of Defense to connect different computer types and led to the development of the Internet.

Transceiver

A transceiver joins two network segments together. Transceivers can also be used to join a segment that uses one medium to a segment that uses a different medium. On a 10BASE-5 network, the transceiver connects the network adapter or other network device to the medium. Transceivers also can be used on 10BASE-2 or 10BASE-T networks to attach devices with AUI ports.

U

UDP

The User Datagram Protocol is a connectionless protocol that resides above IP in the TCP/IP suite

User Name

The USERNAME is the unique name assigned to each person who has access to the LAN.

Utility

It is a program that performs a specific task.

UTP

Unshielded twisted-pair. UTP is a form of cable used by all access methods. It consists of several pairs of wires enclosed in an unshielded sheath.

W

WAN

Wide-Area Network. A wide-area network consists of groups of interconnected computers that are separated by a wide distance and communicate with each other via

common carrier telecommunication techniques.

WEP

WEP is widely used as the basic security protocol in Wi-Fi networks, which secures data transmissions using 64-bit or 128-bit encryption.

Windows

Windows is a graphical user interface for workstations that use DOS.

WPA

WPA (Wi-Fi Protected Access) is used to improve the security of Wi-Fi networks, replacing the current WEP standard. It uses its own encryption, Temporal Key Integrity Protocol (TKIP), to secure data during transmission.

WPA2

Wi-Fi Protected Access 2, the latest security specification that provides greater data protection and network access control for Wi-Fi networks. WPA2 uses the government-grade AES encryption algorithm and IEEE 802.1X-based authentication, which are required to secure large corporate networks.

Technical Support

E-mail: support@airlink101.com

Toll Free: 1-888-746-3238

Web Site: www.airlink101.com

* Theoretical maximum wireless signal rate derived from IEEE standard 802.11 specifications. Actual data throughput will vary. Network conditions and environmental factors, including volume of network traffic, building materials and construction, mix of wireless products used, radio frequency interference (e.g., cordless telephones and microwaves) as well as network overhead lower actual data throughput rate. Compatibility with 802.11n devices from other manufactures is not guaranteed. Specifications are subject to change without notice. Photo of product may not reflect actual content. All products and trademarks are the property of their respective owners. Copyright ©2011 Airlink101®

Free Manuals Download Website

<http://myh66.com>

<http://usermanuals.us>

<http://www.somanuals.com>

<http://www.4manuals.cc>

<http://www.manual-lib.com>

<http://www.404manual.com>

<http://www.luxmanual.com>

<http://aubethermostatmanual.com>

Golf course search by state

<http://golfingnear.com>

Email search by domain

<http://emailbydomain.com>

Auto manuals search

<http://auto.somanuals.com>

TV manuals search

<http://tv.somanuals.com>