

CSD-TD51 U(S),K(S),EZ(S)

CSD-TD52 U(W)

CSD-TD53 U(L)

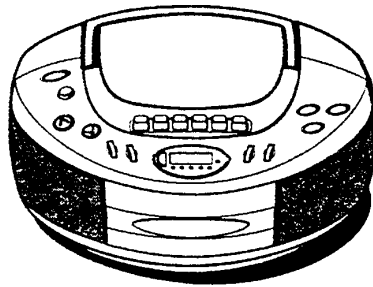

SERVICE MANUAL

COMPACT DISC RADIO
CASSETTE RECORDER

- BASIC TAPE MECHANISM : TN-21ZVC-2000
- BASIC CD MECHANISM : DA11T3C

This Service Manual is the "Revision Publishing" and replaces "Simple Manual"
CSD-TD51 U(S)/TD52 U(W)/TD53 U(L)(S/M Code No. 09-003-343-3T1)
CSD-TD51 EZ(S),K(S)(S/M Code No. 09-003-343-3T2).

aiwa
S/M Code No. 09-003-343-3R1

REVISION
DATA

SPECIFICATIONS

U MODEL

Tuner section

Frequency range, antenna — FM: 87.5 - 108.0 MHz Rod antenna,
AM: 530/531 - 1,710/1,602 kHz (10/9 kHz step) Ferrite bar antenna

Deck section

Track format — 4 tracks, 2 channels / Frequency range — Normal tape:
50 - 12,500 Hz (EIAJ) / Recording system — AC bias / Erasing system —
Magnet erase / Heads — Recording/playback head (1), Erasure head (1)

CD player section

Disc — Compact disc / Scanning method — Non-contact optical scanner
(semiconductor laser)

General

Speaker — 80 mm cone type (2) / Output — Headphones jack (stereo
mini-jack) / Power output — 2.5 W + 2.5 W (EIAJ 7 ohms DC) / Power
requirements — DC 12 V using eight size C (R14) batteries, AC 120 V,
60 Hz / Power consumption — 15 W
Dimensions (W × H × D) — 302 × 162 × 253 mm (12 × 6 1/2 × 10 in.)
Weight (excluding batteries) — 2.7 kg (5 lbs. 15 oz.)

- Design and specifications are subject to change without notice.

EZ MODEL

Tuner section

Frequency range, antenna — FM: 87.5 - 108.0 MHz Rod antenna,
MW: 531/530 - 1,602/1,710 kHz (9/10 kHz step) Ferrite bar antenna,
LW: 153 - 288 kHz Ferrite bar antenna

Deck section

Track format — 4 tracks, 2 channels / Frequency range — Normal tape:
50 - 12,500 Hz (EIAJ) / Recording system — AC bias / Erasing system —
Magnet erase / Heads — Recording/playback head (1), Erasure head (1)

CD player section

Disc — Compact disc / Scanning method — Non-contact optical scanner
(semiconductor laser)

General

Speaker — 80 mm cone type (2) / Output — Headphones jack (stereo
mini-jack) / Power output — 2.9 W + 2.9 W (DIN MUSIC POWER), 2.5 W
+ 2.5 W (EIAJ 7 ohms DC), 1.9 W + 1.9 W (DIN 1% Rated Power) /
Power requirements — DC 12 V using eight size C (R14) batteries, AC
230 V, 50 Hz / Power consumption — 14 W
Dimensions (W × H × D) — 302 × 162 × 253 mm
Weight (excluding batteries) — 2.7 kg

- Design and specifications are subject to change without notice.

K MODEL

Tuner section

Frequency range, antenna — FM: 87.5 - 108.0 MHz Rod antenna,
MW: 531/530 - 1,602/1,710 kHz (9/10 kHz/step) Ferrite bar antenna,
LW: 153 - 288 kHz Ferrite bar antenna

Deck section

Track format — 4 tracks, 2 channels / Frequency range — Normal tape:
50 - 12,500 Hz (EIAJ) / Recording system — AC bias / Erasing system —
Magnet erase / Heads — Recording/playback head (1), Erasure head (1)

CD player section

Disc — Compact disc / Scanning method — Non-contact optical scanner
(semiconductor laser)

General

Speaker — 80 mm cone type (2) / Output — Headphones jack (stereo
mini-jack) / Power output — 2.5 W + 2.5 W (EIAJ 7 ohms DC), 1.9 W +
1.9 W (DIN 1% Rated Power) / Power requirements — DC 12 V using
eight size C (R14) batteries, AC 230 V, 50 Hz / Power consumption —
14 W
Dimensions (W × H × D) — 302 × 162 × 253 mm
Weight (excluding batteries) — 2.7 kg

- Design and specifications are subject to change without notice.

PROTECTION OF EYES FROM LASER BEAM DURING SERVICING

This set employs laser. Therefore, be sure to follow carefully the instructions below when servicing.

WARNING!

WHEN SERVICING, DO NOT APPROACH THE LASER EXIT WITH THE EYE TOO CLOSELY. IN CASE IT IS NECESSARY TO CONFIRM LASER BEAM EMISSION. BE SURE TO OBSERVE FROM A DISTANCE OF MORE THAN 30cm FROM THE SURFACE OF THE OBJECTIVE LENS ON THE OPTICAL PICK-UP BLOCK.

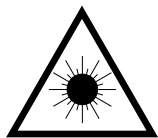

- Caution: Invisible laser radiation when open and interlocks defeated avoid exposure to beam.
- Advarsel: Usynlig laserstråling ved åbning, når sikkerhedsafbrydere er ude af funktion. Undgå udsættelse for stråling.

VAROITUS!

Laitteen Käyttäminen muulla kuin tässä käyttöohjeessa mainitulla tavalla saattaa altistaa käyttäjän turvallisuusluokan 1 ylittävälle näkymättömälle lasersäteilylle.

WARNING!

Om apparaten används på annat sätt än vad som specificeras i denna bruksanvisning, kan användaren utsättas för osynlig laserstråling, som överskrider gränsen för laserklass 1.

CAUTION

Use of controls or adjustments or performance of procedures other than those specified herein may result in hazardous radiation exposure.

ATTENTION

L'utilisation de commandes, réglages ou procédures autres que ceux spécifiés peut entraîner une dangereuse exposition aux radiations.

ADVARSEL!

Usynlig laserstråling ved åbning, når sikkerhedsafbrydere er ude af funktion. Undgå udsættelse for stråling.

This Compact Disc player is classified as a CLASS 1 LASER product.

The CLASS 1 LASER PRODUCT label is located on the rear exterior.

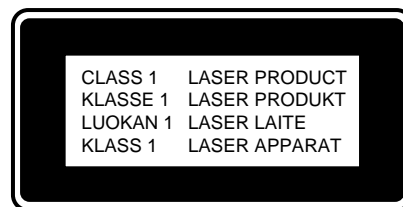

Precaution to replace Optical block (SF-P101NR)

Body or clothes electrostatic potential could ruin laser diode in the optical block. Be sure ground body and workbench, and use care the clothes do not touch the diode.

- 1) After the connection, remove solder shown in the right figure.

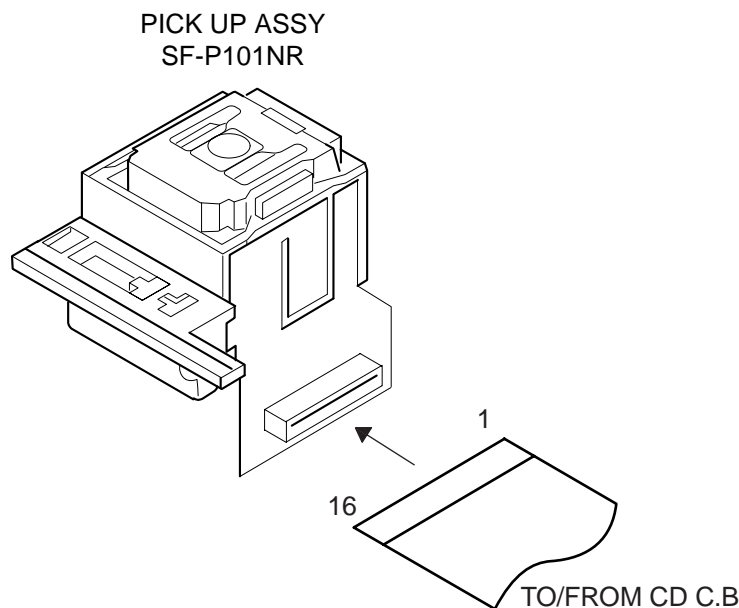
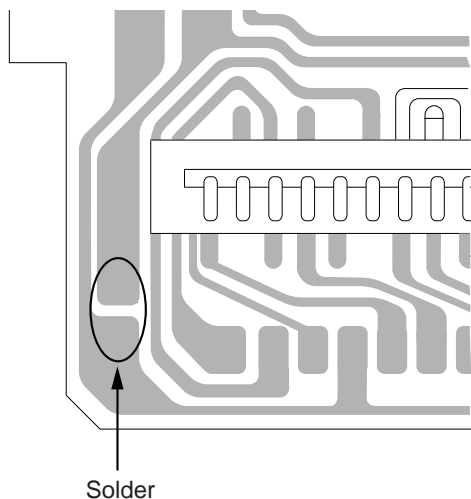

ELECTRICAL MAIN PARTS LIST

DESCRIPTIONで判断できない物は "REFERENCE NAME LIST" を参照してください。
 If can't understand for Description please kindly refer to "REFERENCE NAME LIST".

REF. NO	PART NO.	KANRI NO.	DESCRIPTION	REF. NO	PART NO.	KANRI NO.	DESCRIPTION
IC				C317	87-010-197-080		CAP, CHIP 0.01 DM
	87-A21-550-010	IC,TA2149N		C801	87-010-248-080		CAP, ELECT 220-10V
	87-A21-185-040	C-IC,LC72121M		C805	87-012-365-080		C-CAP,S 0.027-25VBK
	87-A21-064-010	IC,LA4227		C806	87-012-365-080		C-CAP,S 0.027-25VBK
	87-A21-520-040	C-IC,M61509FP		C807	87-010-405-080		CAP, ELECT 10-50V
	87-A20-446-010	C-IC,LA9241ML		C808	87-010-405-080		CAP, ELECT 10-50V
	87-A20-459-010	C-IC,LC78622ED		C809	87-010-401-080		CAP, ELECT 1-50V
	87-A21-093-010	IC,LA6541D		C810	87-010-401-080		CAP, ELECT 1-50V
	8A-CH4-661-010	C-IC,LC867132V-5P07		C811	87-010-178-080		CHIP CAP 1000P
	87-A21-431-010	IC,BA4560N		C812	87-010-178-080		CHIP CAP 1000P
				C816	87-010-180-080		C-CER 1500P
				C817	87-010-180-080		C-CER 1500P
TRANSISTOR				C821	87-010-401-080		CAP, ELECT 1-50V
	89-327-143-080	TR,2SC2714 (0.1W)		C822	87-010-401-080		CAP, ELECT 1-50V
	87-026-447-080	TR,2SC1740S R		C823	87-010-178-080		CHIP CAP 1000P
	89-111-624-080	TR,2SA1162Y		C824	87-010-178-080		CHIP CAP 1000P
	87-026-213-080	CHIP-TR,DTC114YK		C829	87-010-178-080		CHIP CAP 1000P
	89-503-025-010	C-FET,2SK302GR<51 K<S>,51 EZ<S>>		C830	87-010-178-080		CHIP CAP 1000P
	89-320-011-080	TR,2SC2001 (15W)<51 K<S>,51 EZ<S>>		C833	87-018-195-080		CAP, CER 1200P-16V
	87-026-230-080	CHIP-TR,DTA114YK<51 K<S>,51 EZ<S>>		C834	87-010-248-080		CAP, ELECT 220-10V
	89-327-125-080	CHIP TR,2SC2712GR		C835	87-010-322-080		C-CAP,S 100P-50 CH
	89-112-965-080	TR,2SA1296 (0.75W)		C836	87-010-322-080		C-CAP,S 100P-50 CH
	87-026-463-080	TR,2SA933S (0.3W)		C843	87-010-197-080		CAP, CHIP 0.01 DM
	87-026-291-080	TR,DTC124XS		C844	87-018-124-080		CAP, CER 270P-50V
	89-213-702-080	TR,2SB1370E		C845	87-010-178-080		CHIP CAP 1000P
	87-026-462-080	TR,2SC1740 S(RS 0.3W)		C846	87-010-263-080		CAP, ELECT 100-10V
	89-318-154-080	TR,2SC1815 (0.4W)		C851	87-010-186-080		CAP,CHIP 4700P
	89-109-332-380	TR,2SA933RS		C852	87-010-178-080		CHIP CAP 1000P
	89-113-187-080	TR,2SA1318TU		C853	87-018-211-080		CAP, CER 0.01-50
	87-026-295-080	TR,DTC144TK		CN201	87-099-018-010		CONN,16P
	87-026-237-080	CHIP-TR,DTC124XK		CN801	87-A60-110-010		CONN,4P V S2M-4W
	87-026-239-080	TR,DTC114TK (0.2W)		CNA302	8A-CD9-629-010		CONN ASSY,6P MA-TU
	87-026-464-080	TR,DTC114TS (0.3W)		CNA801	8A-CD9-630-010		CONN ASSY, 4P RPH
				L801	87-007-342-010		COIL,OSC 85K BIAS
				SW801	8Z-CD9-609-010		SW,SL 1-6-2 PS62D01
DIODE				CD C.B			
	87-070-345-080	DIODE,IN4148		C30	87-010-260-080		CAP, ELECT 47-25V
	87-A40-616-070	VARI-CAP,SVC384(S/T)		C251	87-010-404-080		CAP, ELECT 4.7-50V
	87-A40-128-080	C-VARI-CAP,HVU202A		C261	87-010-402-080		CAP, ELECT 2.2-50V
	87-017-072-080	ZENER,HZS3B1		C262	87-010-402-080		CAP, ELECT 2.2-50V
	87-027-399-080	ZENER,HZ7A3L (200MA)<51 U<S>,53 U<L>,52 U<W>>		C263	87-010-178-080		CHIP CAP 1000P
	87-027-607-080	ZENER,HZ7B3L<51 K<S>,51 EZ<S>>		C264	87-010-178-080		CHIP CAP 1000P
	87-A40-648-080	ZENER,MTZJ8.2A		C265	87-010-263-080		CAP, ELECT 100-10V
	87-017-978-080	DIODE,IN4003		C266	87-010-263-080		CAP, ELECT 100-10V
	87-020-465-080	DIODE,1SS133 (110MA)		C267	87-010-112-080		CAP, ELECT 100-16V
	87-027-702-080	DIODE,ZENER HZ6C2L (200MA)		C268	87-010-112-080		CAP, ELECT 100-16V
	87-A40-465-010	DIODE,FR202		C271	87-010-237-080		CAP, ELECT 1000-16V
				C272	87-010-237-080		CAP, ELECT 1000-16V
				C278	87-010-405-080		CAP, ELECT 10-50V
				C279	87-010-385-080		CAP, ELECT 220-25V
MAIN C.B				C301	87-016-495-000		CAP,E 3300-25 M SMG
C211	87-A11-603-080	CAP, S 0.05-16		C306	87-010-404-080		CAP, ELECT 4.7-50V
C212	87-A11-603-080	CAP, S 0.15-16		C307	87-010-401-080		CAP, ELECT 1-50V
C215	87-016-460-080	C-CAP,S 0.22-16 B		C308	87-010-221-080		CAP, ELECT 470-10V
C216	87-016-460-080	C-CAP,S 0.22-16 B		C311	87-010-263-080		CAP, ELECT 10-10V
C231	87-010-213-080	C-CAP,S 0.015-50 B		C312	87-010-385-080		CAP, ELECT 220-25V
C232	87-010-213-080	C-CAP,S 0.015-50 B		C321	87-010-197-080		CAP, CHIP 0.01 DM
C233	87-A10-201-080	C-CAP,S0.33-16 KB		C322	87-010-263-080		CAP, ELECT 100-10V
C234	87-A10-201-080	C-CAP,S0.33-16 KB		C325	87-010-405-080		CAP, ELECT 10-50V
C235	87-016-669-080	C-CAP,S 0.1-25 K B		C401	87-010-403-080		CAP, ELECT 3.3-50V
C236	87-016-669-080	C-CAP,S 0.1-25 K B		C402	87-010-197-080		CAP, CHIP 0.01 DM
C237	87-010-371-080	CAP, ELECT 470-50V		C403	87-010-263-080		CAP, ELECT 100-10V
C239	87-010-197-080	CAP, CHIP 0.01 DM		C404	87-010-248-080		CAP, ELECT 220-10V
C240	87-010-197-080	CAP, CHIP 0.01 DM		C405	87-010-197-080		CAP, CHIP 0.01 DM
C247	87-010-401-080	CAP, ELECT 1-50V		C406	87-010-374-080		CAP, ELECT 47-10V
C248	87-010-401-080	CAP, ELECT 1-50V		C407	87-010-178-080		CHIP CAP 1000P
C310	87-010-248-080	CAP, ELECT 220-10V		C408	87-010-198-080		CAP, CHIP 0.022
C316	87-010-263-080	CAP,E 100-10		C409	87-010-248-080		CAP, ELECT 220-10V

REF. NO	PART NO.	KANRI NO.	DESCRIPTION	REF. NO	PART NO.	KANRI NO.	DESCRIPTION
C410	87-010-263-080		CAP, ELECT 100-10V	C503	87-010-322-080		C-CAP,S 100P-50 CH
C411	87-A11-177-080		C-CAP,S 0.15-16 K B	C504	87-010-322-080		C-CAP,S 100P-50 CH
C412	87-010-401-080		CAP, ELECT 1-50V	C505	87-010-322-080		C-CAP,S 100P-50 CH
C413	87-016-369-080		C-CAP,S 0.033-25 B K	C506	87-010-322-080		C-CAP,S 100P-50 CH
C414	87-010-405-080		CAP, ELECT 10-50V	C510	87-016-669-080		C-CAP,S 0.1-25 K B
C416	87-010-545-080		CAP, ELECT 0.22-50V	C831	87-010-198-080		CAP, CHIP 0.022
C417	87-012-157-080		C-CAP,S 330P-50 CH	CN202	8A-CH4-689-010		CONN,3P V 2.5
C418	87-010-213-080		C-CAP,S 0.015-50 B	CN205	87-A60-109-010		CONN,2P V S2M-2W
C419	87-A11-608-080		C-CAP,S 0.33-25 K B	CN301	8A-CH4-689-010		CONN,3P V 2.5
C420	87-016-369-080		C-CAP,S 0.033-25 B K	CN401	87-A60-424-010		CONN,16P V TOC-B
C421	87-A11-177-080		C-CAP,S 0.15-16 K B	CN403	87-099-201-010		CONN,8P 6216 H
C422	87-010-183-080		C-CAP,S 2700P-50 B	CN802	8A-CH4-687-010		CONN,4P V 2.5
C423	87-010-956-080		CHIP-CAP,S 0.068-25B	CNA205	8A-CD9-631-010		CONN ASSY, 2P DOOR
C424	87-010-993-080		C-CAP,S 0.056-25 B	CNA402	8A-CD9-625-010		CONN ASSY,6P CD-ME
C425	87-010-176-080		C-CAP,S 680P-50 SL	CNA802	8A-CD9-631-010		CONN ASSY, 4P TP-ME
C426	87-A11-608-080		C-CAP,S 0.33-25 K B	L401	87-003-102-080		COIL, 10UH
C428	87-010-197-080		CAP, CHIP 0.01 DM	L404	87-003-152-080		COIL, 100UH
C429	87-010-186-080		CAP,CHIP 4700P	SFR430	87-024-437-080		SFR100K,RH063EC
C430	87-012-156-080		C-CAP,S 220P-50 CH	SW205	87-036-389-010		SW, PUSH 1-1-1 R8120125
C431	87-010-545-080		CAP, ELECT 0.22-50V	X401	8Z-CD5-633-010		VIB, CER16.93MHZ FCR16.93M2
C432	87-010-374-080		CAP, ELECT 47-10V				
C433	87-010-401-080		CAP, ELECT 1-50V		FRONT C.B		
C434	87-010-184-080		CHIP CAPACITOR 3300P(K)	C601	87-010-313-080		CAP, CHIP 18P
C435	87-010-197-080		CAP, CHIP 0.01 DM	C602	87-010-315-080		C-CAP,S 27P-50 CH
C436	87-010-374-080		CAP, ELECT 47-10V	C603	87-010-319-080		C-CAP,S 56P-50 CH
C437	87-010-404-080		CAP, ELECT 4.7-50V	C604	87-010-312-080		C-CAP,S 15P-50 CH
C438	87-016-669-080		C-CAP,S 0.1-25 K B	C605	87-010-317-080		C-CAP,S 39P-50 CH
C439	87-010-178-080		CHIP CAP 1000P	C607	87-010-196-080		CHIP CAPACITOR,0.1-25
C440	87-010-145-080		C-CAP, S 1P-50 C CH	C608	87-010-196-080		CHIP CAPACITOR,0.1-25
C441	87-010-197-080		CAP, CHIP 0.01 DM	C610	87-010-555-040		CAP,E 100-10 GAS
C442	87-010-312-080		C-CAP,S 15P-50 CH	C611	87-010-196-080		CHIP CAPACITOR,0.1-25
C445	87-012-368-080		C-CAP,S 0.1-50 F	C612	87-A10-189-040		CAP,E 220-10
C446	87-012-368-080		C-CAP,S 0.1-50 F	C613	87-010-495-040		CAP,E 2.2-50 GAS
C447	87-012-368-080		C-CAP,S 0.1-50 F	C614	87-010-196-080		CHIP CAPACITOR,0.1-25
C448	87-010-315-080		C-CAP,S 27P-50 CH	C615	87-010-493-040		CAP,E 0.47-50 GAS
C450	87-012-140-080		CAP 470P	C616	87-010-494-040		CAP,E 1-50 GAS
C451	87-012-156-080		C-CAP,S 220P-50 CH	C620	87-015-785-080		CHIP CAPACITOR, 0.1FZ-25Z
C455	87-010-247-080		CAP, ELECT 100-50V	C625	87-A12-317-080		C-CAP,U 0.1-50 Z F
C457	87-010-312-080		C-CAP,S 15P-50 CH	C627	87-010-196-080		CHIP CAPACITOR,0.1-25
C458	87-010-312-080		C-CAP,S 15P-50 CH	C629	87-A12-317-080		C-CAP,U 0.1-50 Z F
C459	87-010-263-080		CAP, ELECT 100-10V	C630	87-A12-317-080		C-CAP,U 0.1-50 Z F
C460	87-015-819-080		CAPACITOR,0.01	C631	87-A12-317-080		C-CAP,U 0.1-50 Z F
C461	87-010-197-080		CAP, CHIP 0.01 DM	C632	87-A12-317-080		C-CAP,U 0.1-50 Z F
C462	87-010-248-080		CAP, ELECT 220-10V	C633	87-A12-317-080		C-CAP,U 0.1-50 Z F
C463	87-010-197-080		CAP, CHIP 0.01 DM	C635	87-012-195-080		C-CAP,S 100P-50 J CH
C465	87-010-404-080		CAP, ELECT 4.7-50V	C636	87-012-195-080		C-CAP,S 100P-50 J CH
C466	87-012-368-080		C-CAP,S 0.1-50 F	C637	87-012-195-080		C-CAP,S 100P-50 J CH
C467	87-010-263-080		CAP, ELECT 100-10V	C638	87-012-195-080		C-CAP,S 100P-50 J CH
C469	87-012-154-080		C-CAP,S 150P-50 CH	C639	87-012-195-080		C-CAP,S 100P-50 J CH
C470	87-010-544-080		CAP, ELECT 0.1-50V	C640	87-012-195-080		C-CAP,S 100P-50 J CH
C471	87-015-785-080		CHIP CAPACITOR, 0.1FZ-25Z	C641	87-012-195-080		C-CAP,S 100P-50 J CH
C472	87-015-785-080		CHIP CAPACITOR, 0.1FZ-25Z	C642	87-012-195-080		C-CAP,S 100P-50 J CH
C473	87-015-785-080		CHIP CAPACITOR, 0.1FZ-25Z	C643	87-012-195-080		C-CAP,S 100P-50 J CH
C474	87-015-785-080		CHIP CAPACITOR, 0.1FZ-25Z	C644	87-012-195-080		C-CAP,S 100P-50 J CH
C475	87-010-197-080		CAP, CHIP 0.01 DM	C645	87-012-195-080		C-CAP,S 100P-50 J CH
C476	87-010-236-080		CAP,E 1000-10 SME	C646	87-012-195-080		C-CAP,S 100P-50 J CH
C477	87-010-197-080		CAP, CHIP 0.01 DM	C647	87-012-195-080		C-CAP,S 100P-50 J CH
C478	87-010-263-080		CAP, ELECT 100-10V	C648	87-012-195-080		C-CAP,S 100P-50 J CH
C479	87-010-197-080		CAP, CHIP 0.01 DM	C649	87-012-195-080		C-CAP,S 100P-50 J CH
C480	87-010-221-080		CAP, ELECT 470-10V	C650	87-012-195-080		C-CAP,S 100P-50 J CH
C481	87-010-405-080		CAP, ELECT 10-50V	C651	87-012-195-080		C-CAP,S 100P-50 J CH
C482	87-010-405-080		CAP, ELECT 10-50V	C652	87-012-195-080		C-CAP,S 100P-50 J CH
C489	87-012-368-080		C-CAP,S 0.1-50 F	C653	87-012-195-080		C-CAP,S 100P-50 J CH
C490	87-012-368-080		C-CAP,S 0.1-50 F	C654	87-012-195-080		C-CAP,S 100P-50 J CH
C491	87-010-197-080		CAP, CHIP 0.01 DM	C655	87-012-195-080		C-CAP,S 100P-50 J CH
C492	87-010-221-080		CAP, ELECT 470-10V	C656	87-012-195-080		C-CAP,S 100P-50 J CH
C494	87-010-197-080		CAP, CHIP 0.01 DM	C657	87-012-195-080		C-CAP,S 100P-50 J CH
C495	87-016-669-080		C-CAP,S 0.1-25 K B	C658	87-A12-317-080		C-CAP,U 0.1-50 Z F
C501	87-012-368-080		C-CAP,S 0.1-50 F	CN601	87-099-033-010		CONN,16P 6216 H
C502	87-010-322-080		C-CAP,S 100P-50 CH				

REF. NO	PART NO.	KANRI NO.	DESCRIPTION	REF. NO	PART NO.	KANRI NO.	DESCRIPTION
CN602	87-099-201-010		CONN,8P 6216 H	C43	87-012-349-080		C-CAP,S 1000P-50 CH
CNA603	8A-CD9-624-010		CONN ASSY,4P TU-FR	C44	87-010-311-080		CAP 12P
CNA604	8A-CD9-623-010		CONN ASSY,4P KEY	C45	87-010-312-080		C-CAP,S 15P-50 CH
L601	87-003-102-080		COIL, 10UH	C46	87-010-197-080		CAP, CHIP 0.01 DM
LCD601	8Z-CH4-635-010		LCD,HLC7365 ZCH-4	C47	87-010-197-080		CAP, CHIP 0.01 DM
LED602	88-CD6-630-010		LED,934ID RED	C48	87-010-197-080		CAP, CHIP 0.01 DM
LED603	88-CD6-630-010		LED,934ID RED	C49	87-012-140-080		CAP 470P
LED604	88-CD6-630-010		LED,934ID RED	C50	87-010-197-080		CAP, CHIP 0.01 DM
LED606	88-CD6-630-010		LED,934ID RED	C51	87-010-316-080		C-CAP,S 33P-50 CH
LED607	88-CD6-630-010		LED,934ID RED	C52	87-010-197-080		CAP, CHIP 0.01 DM
LED608	88-CD6-630-010		LED,934ID RED	C53	87-010-197-080		CAP, CHIP 0.01 DM
LED610	88-CD6-631-010		LED,934GD GRN	C54	87-014-055-080		CAP,PP 820P-100 J<51 K<S>,51
S601	87-A90-164-080		SW,TACT SKQAB(N)				EZ<S>>
S604	87-A90-164-080		SW,TACT SKQAB(N)	C55	87-010-197-080		CAP, CHIP 0.01 DM
S605	87-A90-164-080		SW,TACT SKQAB(N)	C71	87-010-197-080		CAP, CHIP 0.01 DM
				C72	87-010-263-080		CAP, ELECT 100-10V
S606	87-A91-704-080		SW,TACT EVQ 214 05R				
S607	87-A91-704-080		SW,TACT EVQ 214 05R	C73	87-010-197-080		CAP, CHIP 0.01 DM
S611	87-A90-164-080		SW,TACT SKQAB(N)	C75	87-010-197-080		CAP, CHIP 0.01 DM
S613	87-A90-164-080		SW,TACT SKQAB(N)	C91	87-012-140-080		CAP 470P
S614	87-A91-704-080		SW,TACT EVQ 214 05R	C92	87-010-197-080		CAP, CHIP 0.01 DM
				C93	87-010-197-080		CAP, CHIP 0.01 DM
S615	87-A91-704-080		SW,TACT EVQ 214 05R				
X601	87-030-273-010		VIB,XTAL 32.768K5PPM	CF1	87-A91-094-010		FLTR,CDA10.7 MG80A
X602	87-030-376-080		VIB,CER CSA5.76MG200	CF2	87-008-261-010		FILTER, SFE10.7MA5-A
				CF3	87-008-261-010		FILTER, SFE10.7MA5-A
				CN2	87-099-854-010		CONN,6P S2M-6W
				CN3	87-A60-110-010		CONN,4P V S2M-4W
TUNER C.B							
C1	87-010-314-080		C-CAP,S 22P-50V	CN605	87-A60-113-010		CONN,2P H S2M-2WR
C2	87-010-316-080		C-CAP,S 33P-50 CH	HD1	88-CD6-661-010		HLDL,BAR ANT.
C3	87-010-314-080		C-CAP,S 22P-50V	HD2	88-CD6-661-010		HLDL,BAR ANT.
C5	87-A11-067-080		C-CAP,S 1-10 K B	L2	87-A50-560-010		COIL,FM BPF(ACD)
C6	87-010-313-080		CAP, CHIP 18P<51 U<S>,53 U<L>,52 U<W>>	L3	8A-CH4-670-010		BAR-ANT,MW 2B-ACH(COI)<51 U<S>,53 U<L>,52 U<W>>
C7	87-014-049-080		CAP,PP 470P-100 J	L3	8A-CH4-671-010		BAR-ANT,MW/LW 3B-ACH(COI)<51 K<S>,51 EZ<S>>
C8	87-012-349-080		C-CAP,S 1000P-50 CH	L4	87-A50-420-010		COIL,MW OSC(SYN)
C10	87-010-197-080		CAP, CHIP 0.01 DM	L5	87-A50-566-010		COIL,FM RF EX(ACH)
C11	87-010-197-080		CAP, CHIP 0.01 DM	L6	87-A50-567-010		COIL,FM OSC(ACH)
C12	87-010-197-080		CAP, CHIP 0.01 DM	L7	87-A91-308-010		FLTR,PCFAZH- 450T (TOK)
C13	87-010-150-080		C-CAP,S 6P-50 CH	L8	87-005-849-080		COIL,10UH(CECS)
C14	87-010-303-080		C-CAP,S 330P-50CH	L51	87-A50-421-010		COIL,LW OSC(SYN)<51 K<S>,51 EZ<S>>
C15	87-012-349-080		C-CAP,S 1000P-50 CH				
C16	87-010-374-080		CAP, ELECT 47-10V	LED601	88-CD6-630-010		LED,934ID RED
C17	87-010-198-080		CAP, CHIP 0.022	LED609	88-CD6-630-010		LED,934ID RED
C18	87-015-835-080		C-CAP,0.047 D	TC1	87-011-254-080		TRIMER,20P LAR
C19	87-010-263-080		CAP, ELECT 100-10V	TC51	87-A91-659-010		TRIMMER,50P 4.0X4.5 ECRL<51 K<S>,51 EZ<S>>
C20	87-010-404-080		CAP, ELECT 4.7-50V				
C21	87-010-197-080		CAP, CHIP 0.01 DM	X1	87-A70-061-010		VIB,XTAL 4.500MHZ CSA-309
C22	87-010-197-080		CAP, CHIP 0.01 DM				
C23	87-010-197-080		CAP, CHIP 0.01 DM				
C24	87-015-770-080		C-CHIP,330P(SL)K	H.P. CB			
C25	87-016-460-080		C-CAP,S 0.22-16 B				
C27	87-A11-067-080		C-CAP,S 1-10 K B	CN101	8A-CD9-628-010		CONN ASSY,3P MA-HP
C28	87-016-669-080		C-CAP,S 0.1-25 K B	CN102	87-A60-685-010		CONN,4P H WHT EH
				HP1	87-A60-569-010		JACK,HTJ-035-18
C29	87-016-669-080		C-CAP,S 0.1-25 K B				
C30	87-010-213-080		C-CAP,S 0.015-50 B<51 K<S>,51 EZ<S>>	BATT1 C.B			
C30	87-010-198-080		CAP, CHIP 0.022<51 U<S>,53 U<L>,52 U<W>>	C901	87-010-192-080		C-CAP,S 0.022-50 F
C31	87-010-213-080		C-CAP,S 0.015-50 B<51 K<S>,51 EZ<S>>	C902	87-010-192-080		C-CAP,S 0.022-50 F
				C903	87-010-192-080		C-CAP,S 0.022-50 F
C31	87-010-198-080		CAP, CHIP 0.022<51 U<S>,53 U<L>,52 U<W>>	C904	87-010-192-080		C-CAP,S 0.022-50 F
				CNA901	8A-CD9-627-010		CONN ASSY,3P PWR
C33	87-012-358-080		C-CAP,S 0.47-10 F Z	APR901	87-A90-092-080		PROTECTOR,2.5A 491<51 K<S>,51 EZ<S>>
C34	87-012-358-080		C-CAP,S 0.47-10 F Z				
C35	87-015-819-080		CAPACITOR,0.01	SP901	87-CD6-213-010		SPR-C,BATT (-)
C36	87-010-263-080		CAP, ELECT 100-10V	SP902	87-CD6-213-010		SPR-C,BATT (-)
C37	87-010-197-080		CAP, CHIP 0.01 DM				
C38	87-010-374-080		CAP, ELECT 47-10V	BATT2 C.B			
C39	87-010-404-080		CAP, ELECT 4.7-50V				
C40	87-010-197-080		CAP, CHIP 0.01 DM	SP903	87-CD6-213-010		SPR-C,BATT (-)
C41	87-012-349-080		C-CAP,S 1000P-50 CH	SP904	87-CD6-213-010		SPR-C,BATT (-)
C42	87-012-349-080		C-CAP,S 1000P-50 CH				

REF. NO	PART NO.	KANRI NO.	DESCRIPTION
---------	----------	-----------	-------------

MOTOR C.B

M2	9X-262-576-910		MOTOR GEAR ASSY
PIN3	91-564-722-110		CONNECTOR 6P
SW1	91-572-085-120		LEAF SW

KEY C.B

S608	87-A91-704-080		SW,TACT EVQ 214 05R
S609	87-A90-164-080		SW,TACT SKQAB(N)
S610	87-A90-164-080		SW,TACT SKQAB(N)

- Regarding connectors, they are not stocked as they are not the initial order items. The connectors are available after they are supplied from connector manufacturers upon the order is received.

チップ抵抗部品コード/CHIP RESISTOR PART CODE

チップ抵抗部品コードの成り立ち

Chip Resistor Part Coding

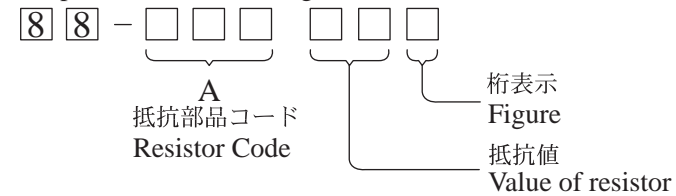

チップ抵抗
Chip resistor

容量 Wattage	種類 Type	許容誤差 Tolerance	記号 Symbol	寸法/Dimensions (mm)			抵抗コード : A Resistor Code : A	
				外形/Form	L	W		t
1/16W	1005	± 5%	CJ		1.0	0.5	0.35	104
1/16W	1608	± 5%	CJ		1.6	0.8	0.45	108
1/10W	2125	± 5%	CJ		2	1.25	0.45	118
1/8W	3216	± 5%	CJ		3.2	1.6	0.55	128

TRANSISTOR ILLUSTRATION

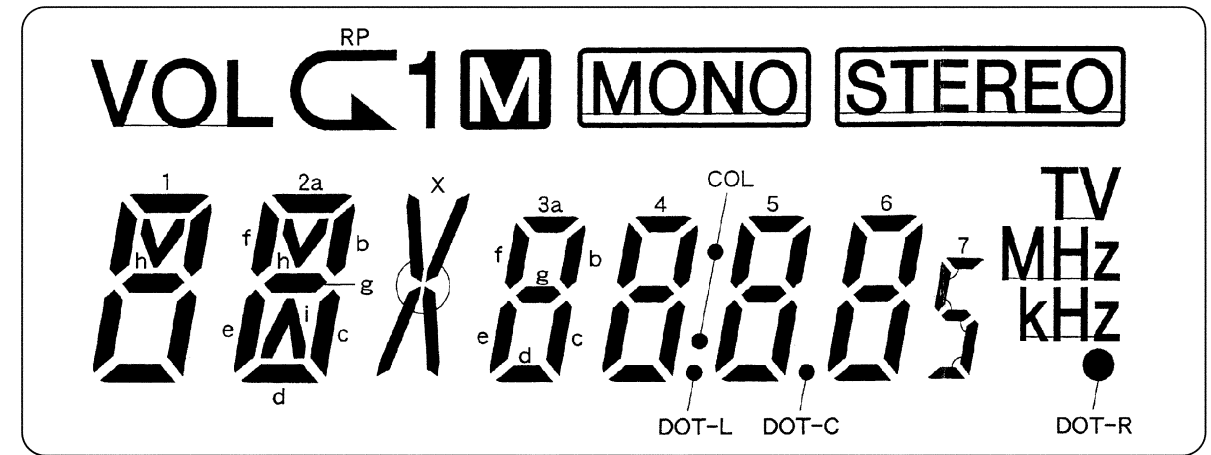
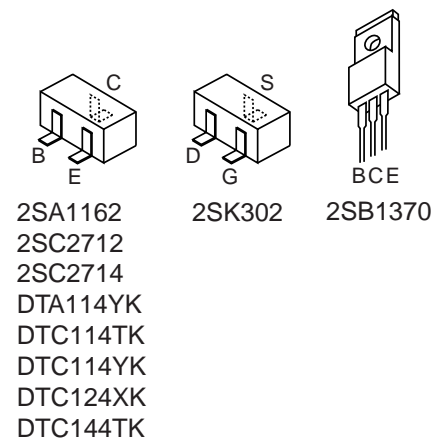
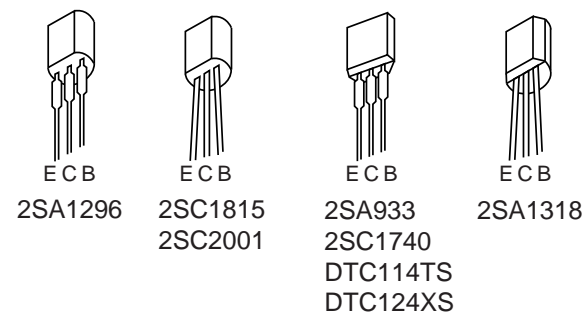

No	COM1	COM2	COM3
1	2b	2c	2d
2	1b	1c	1d
3	1a	1f	1e
4	1h	1g	VOL
5	2a	2f	2e
6	2h	2g	2i
7	3f	3e	RP
8	3a	3g	3d
9	3b	3c	1
10	4f	4e	M
11	4a	4g	4d
12	4b	4c	X
13	COL	DOT-L	MONO
14	5f	5e	DOT-R
15	5a	5g	5d
16	5b	5c	DOT-C
17	6f	6e	STEREO
18	6a	6g	6d
19	6b	6c	7
20	TV	MHz	kHz
21	COM1	---	---
22	---	COM2	---
23	---	---	COM3

WIRING-1 (MAIN/CD)

1 2 3 4 5 6 7 8 9 10 11 12 13 14

A
B
C
D
E
F
G
H
I
J
K

A MAIN C.B

B CD C.B

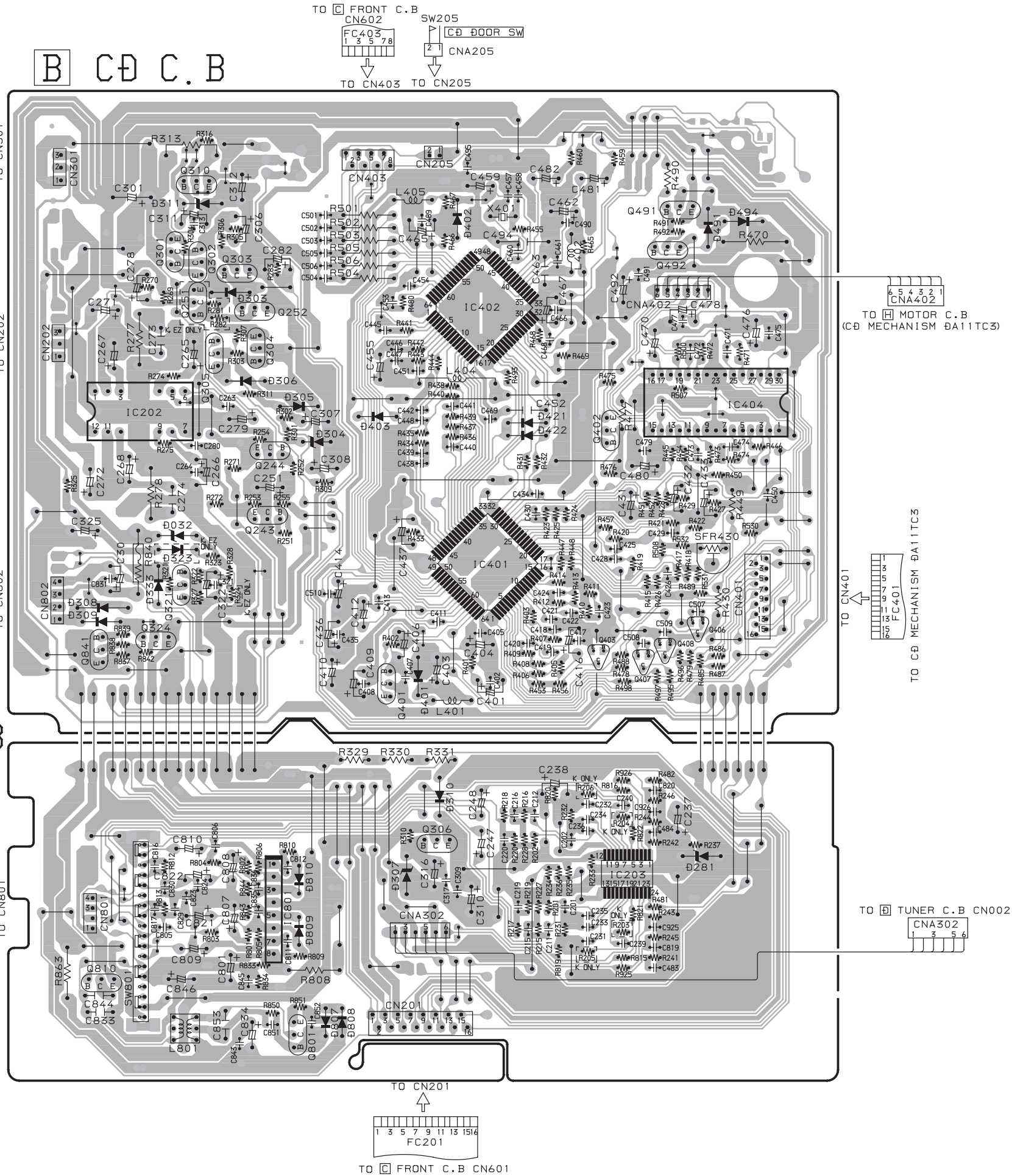
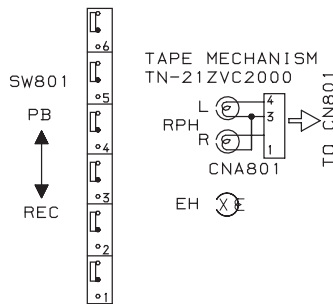
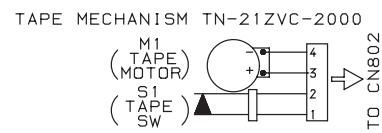

SCHEMATIC DIAGRAM-1 (MAIN)

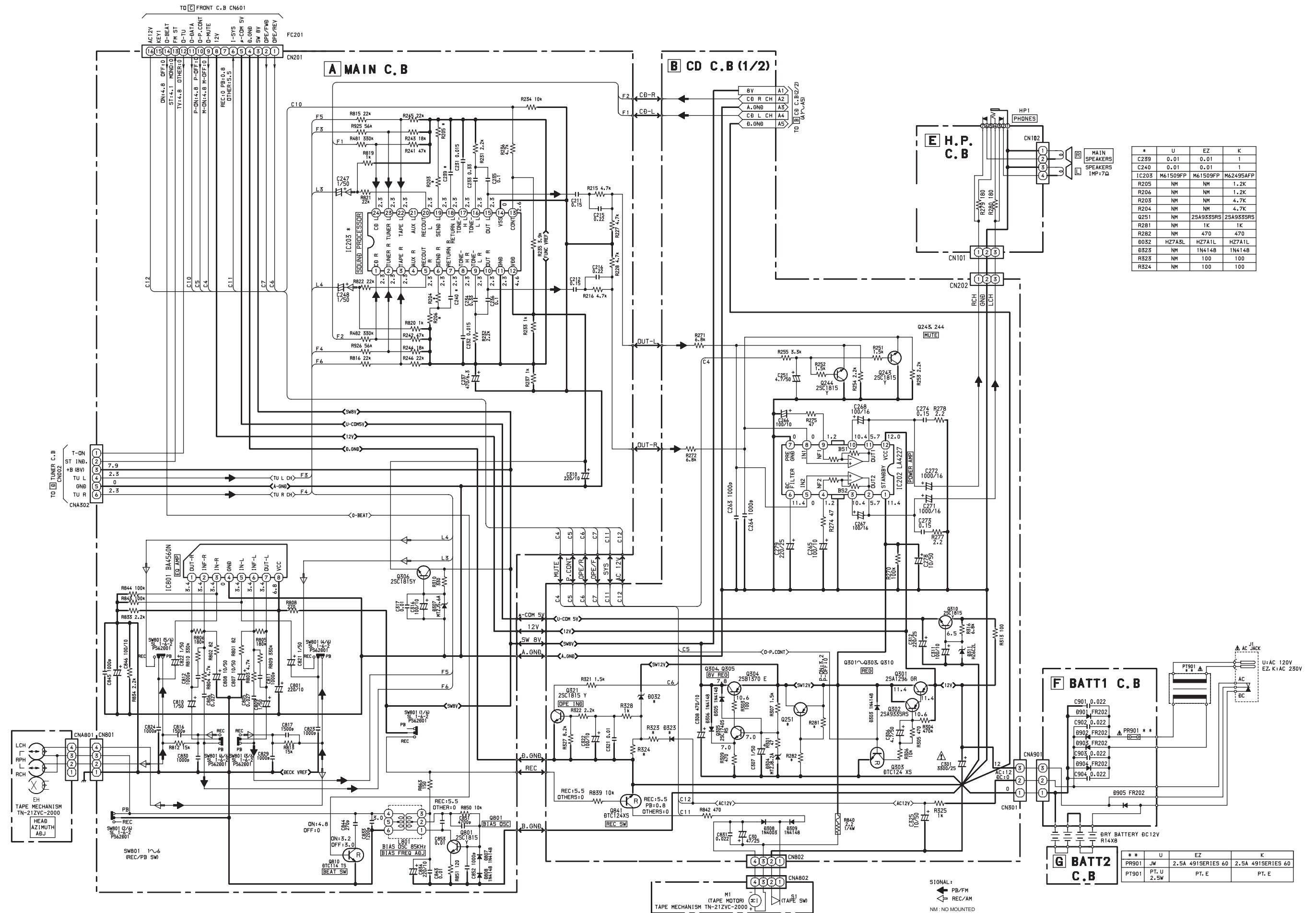

*	U	EZ	K
C239	0.01	0.01	1
C240	0.01	0.01	1
IC203	M61509FP	M61509FP	M62495AFP
R205	NM	NM	1.2K
R206	NM	NM	1.2K
R207	NM	NM	4.7K
R204	NM	NM	4.7K
Q251	NM	2SA953SRS	2SA953SRS
R281	NM	1K	1K
R282	NM	470	470
B052	HZ7A5L	HZ7A1L	HZ7A1L
B525	NM	1N4148	1N4148
R525	NM	100	100
R524	NM	100	100

**	U	EZ	K
PR901	JW	2.5A 491SERIES 60	2.5A 491SERIES 60
PT901	PT. U	PT. E	PT. E

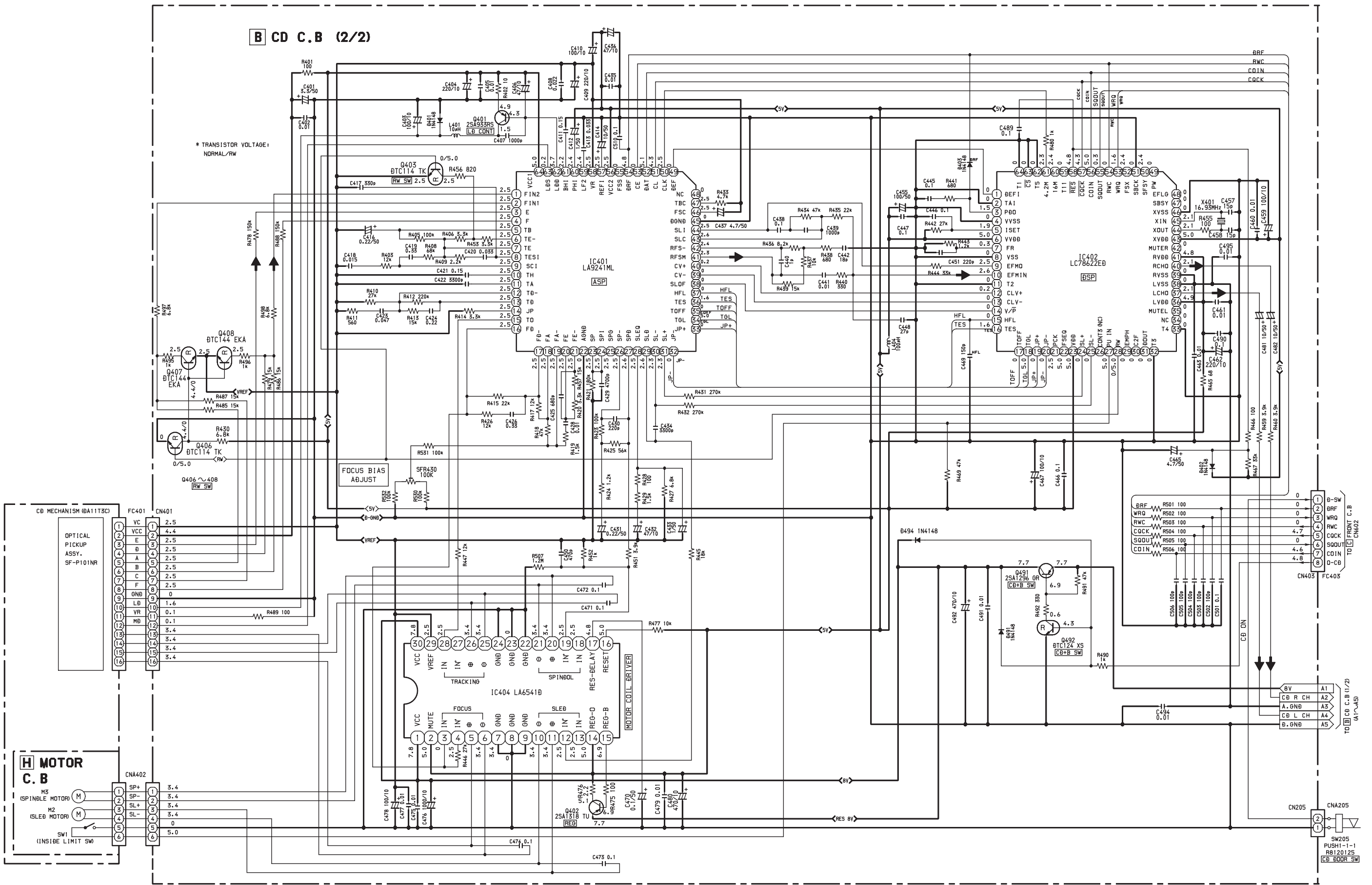

B CD C.B (2/2)

* TRANSISTOR VOLTAGE:
NORMAL/RW

WIRING-2 (MOTOR)

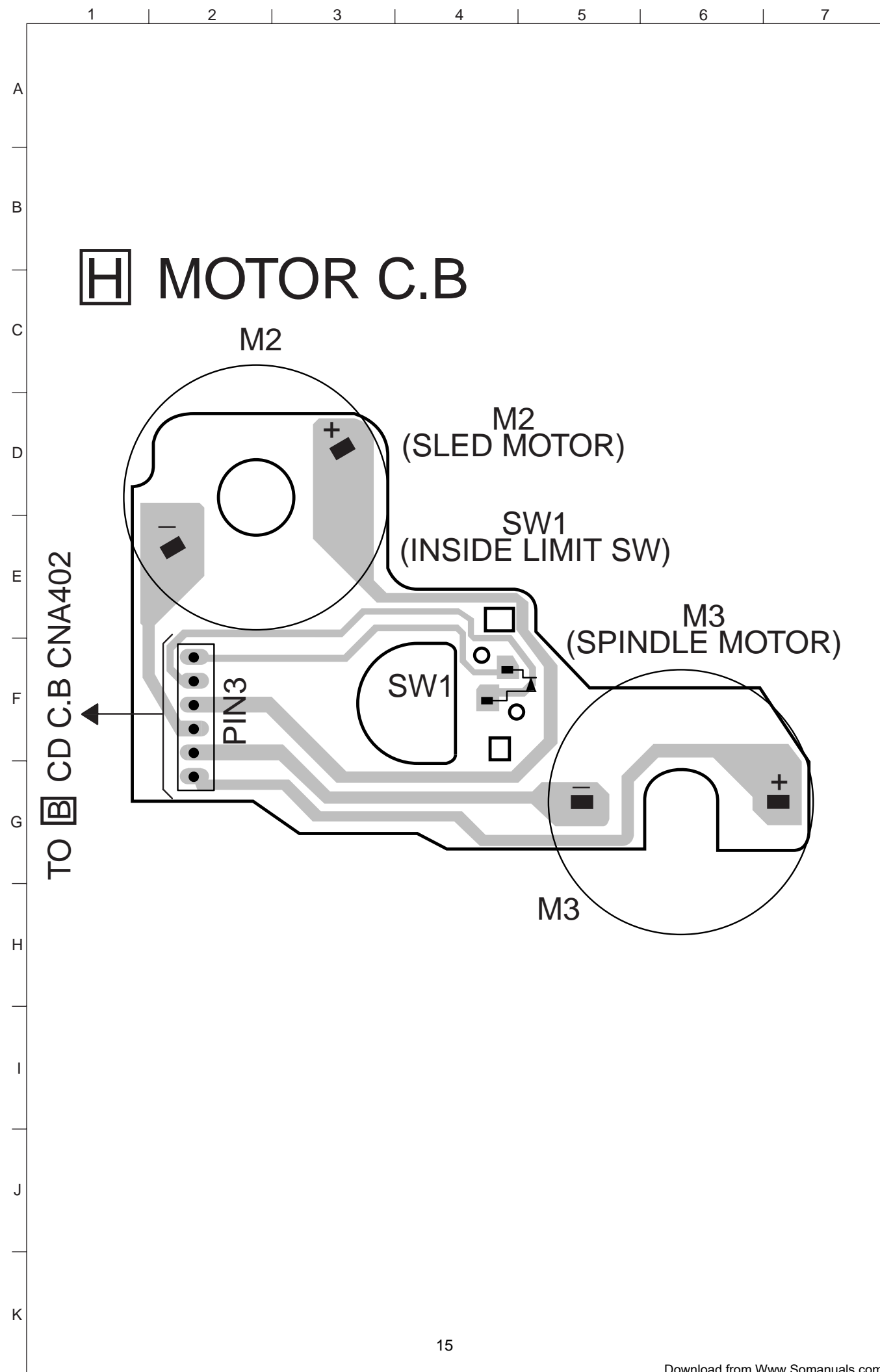

IC BLOCK DIAGRAM

IC, LC7212M

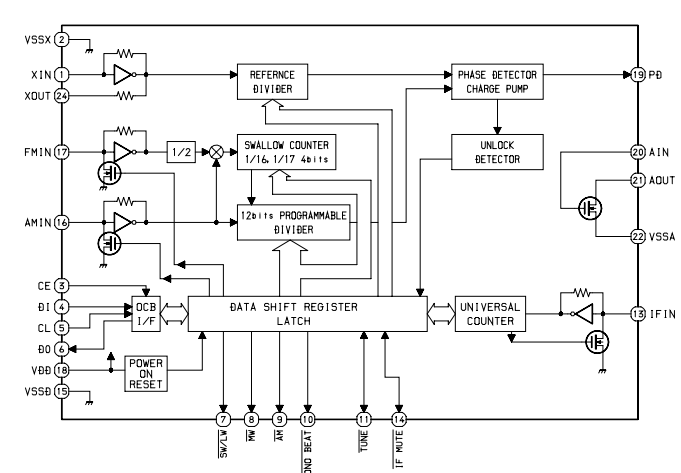

IC, TA2149N

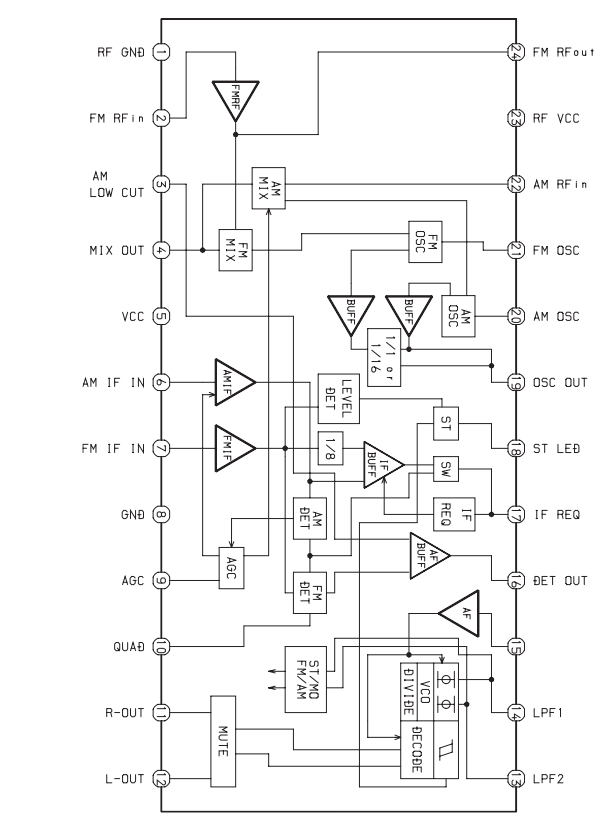

IC, BA4560N

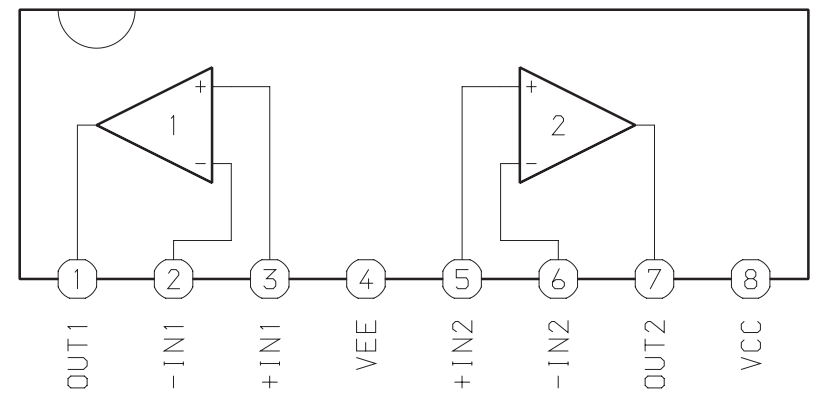

IC, LA6541D

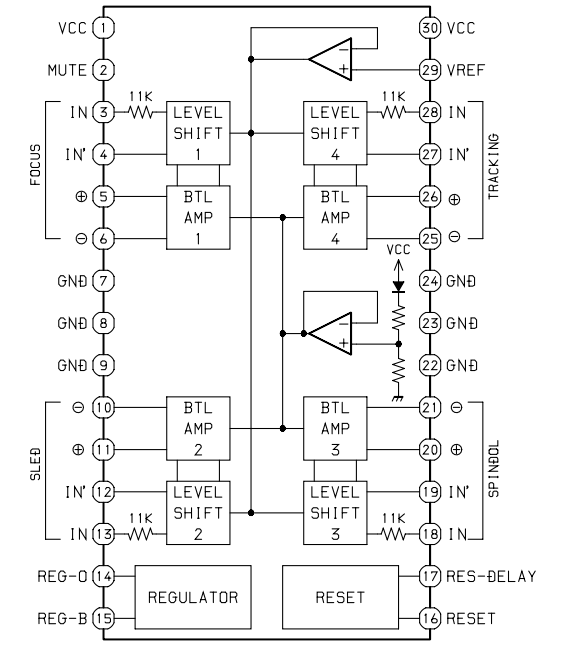

IC, M61509FP

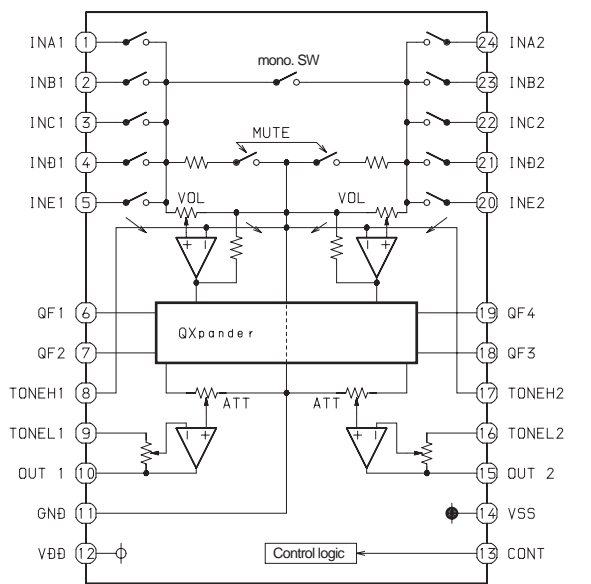

E HP C.B (INSERTED PARTS)

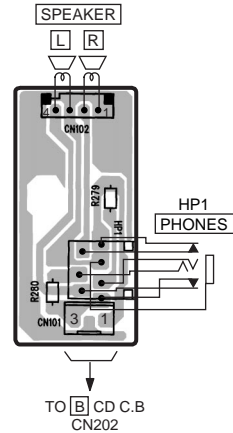

F BATT1 C.B (INSERTED PARTS)

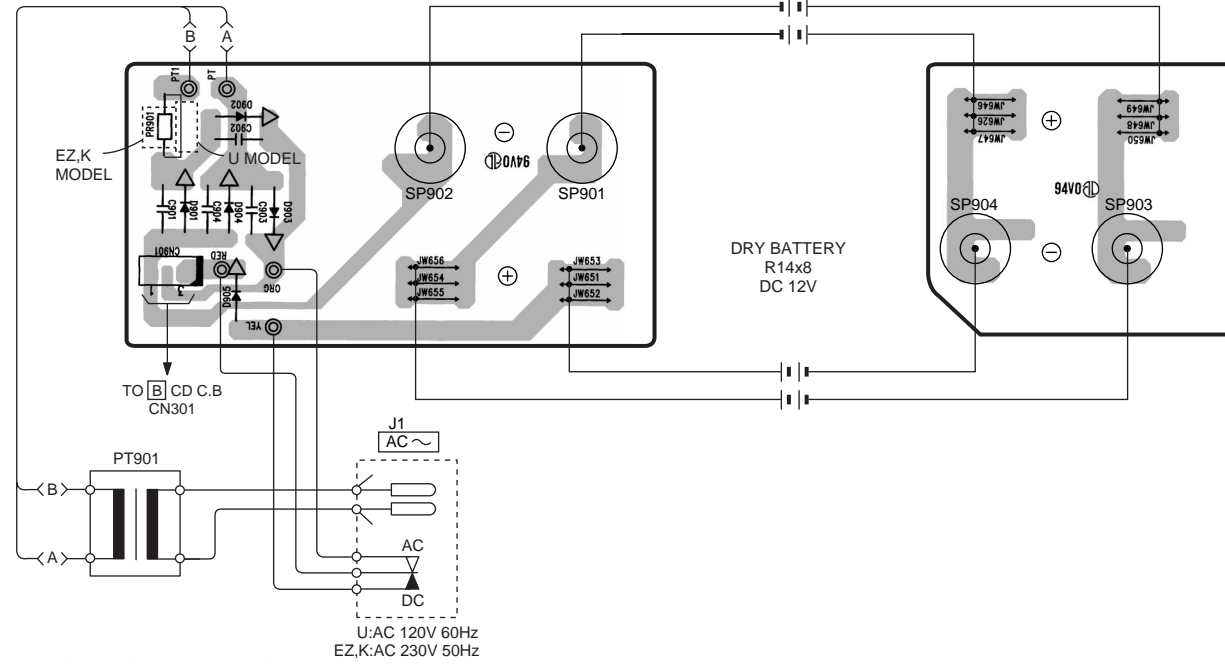

G BATT2 C.B

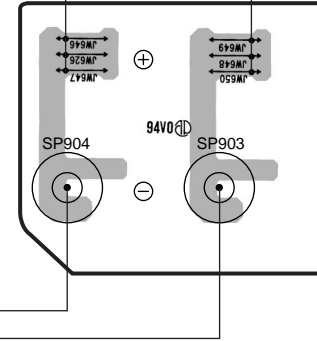

C FRONT C.B (INSERTED PARTS)

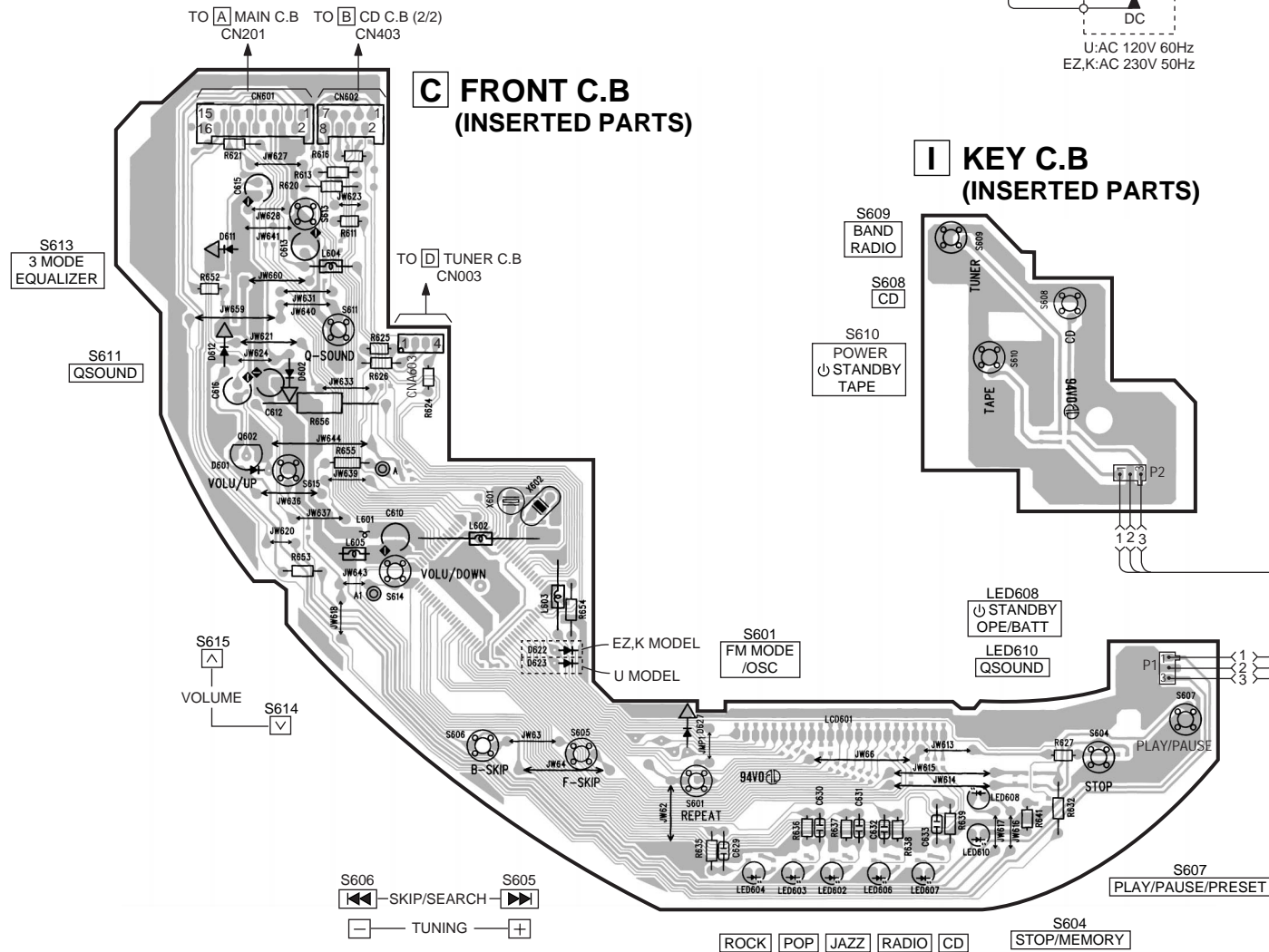

I KEY C.B (INSERTED PARTS)

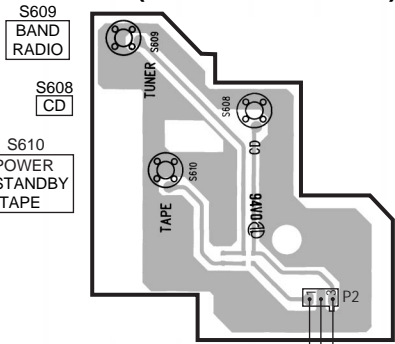

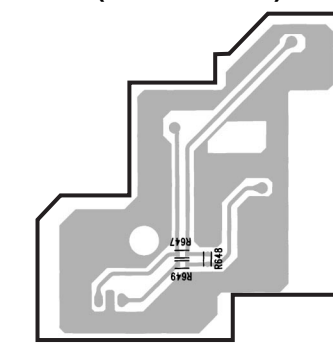

I KEY C.B (CHIP PARTS)

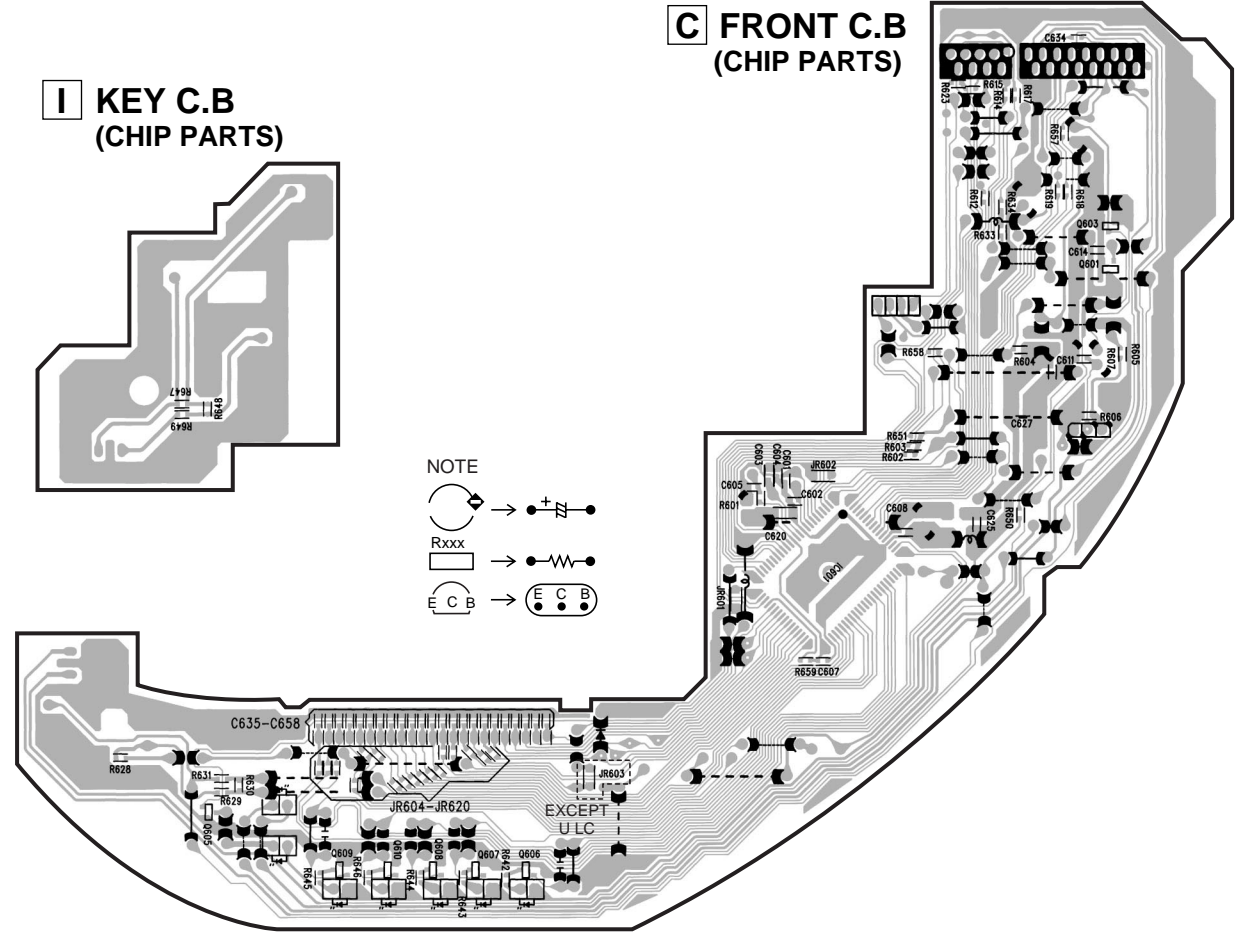

C FRONT C.B (CHIP PARTS)



NOTE
 → + Z
 → R XXX
 → E C B

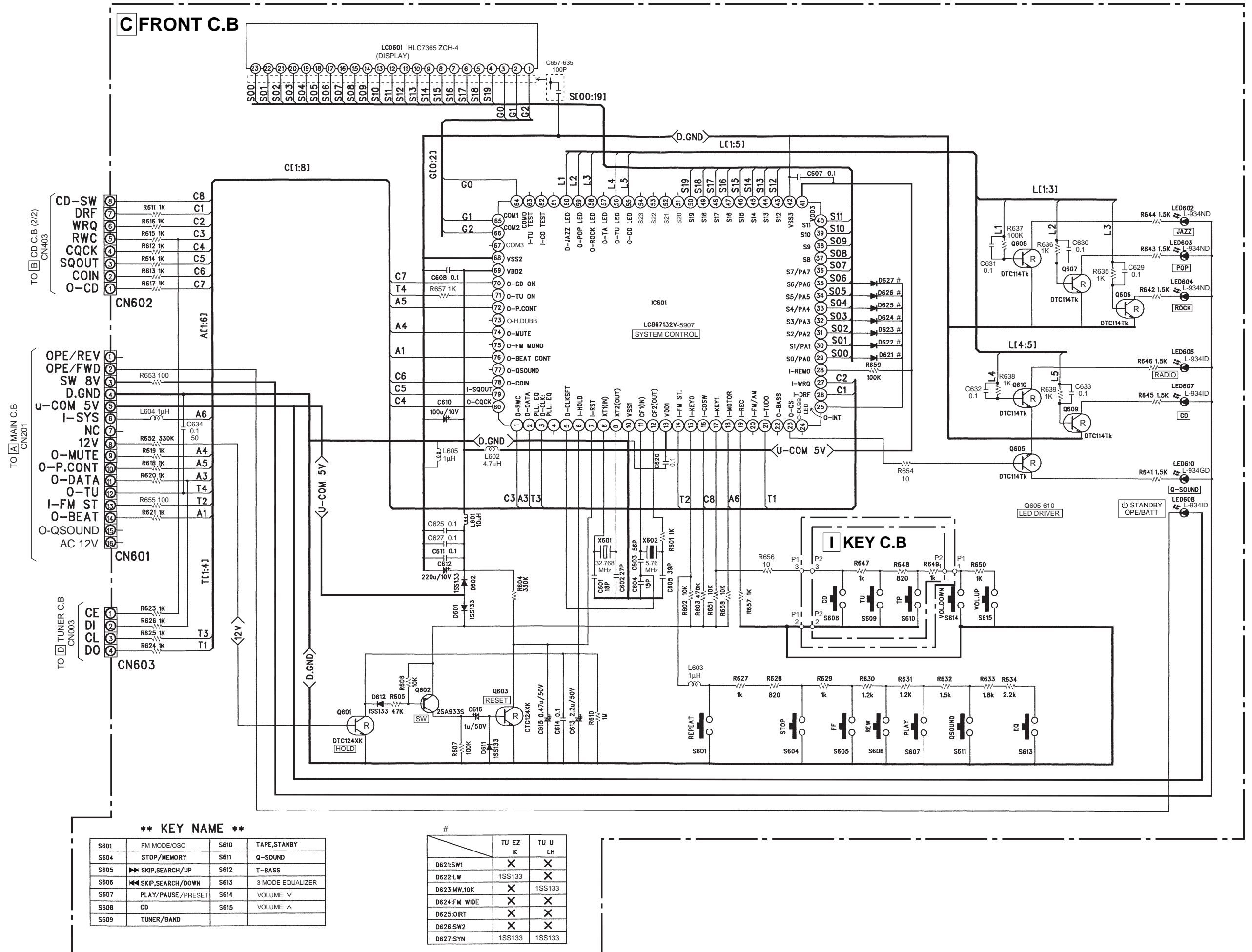

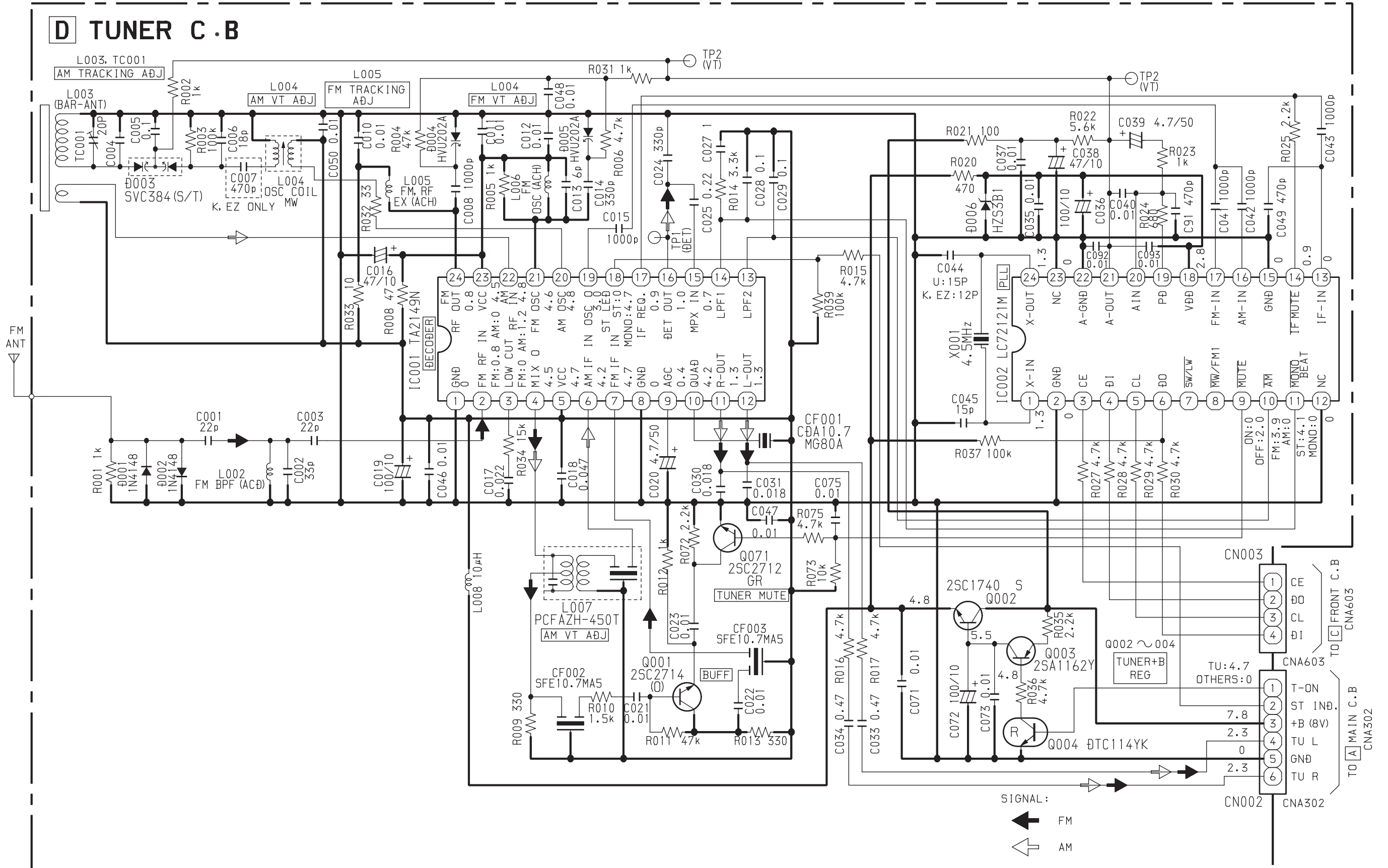

WIRING-4 (TUNER: U)

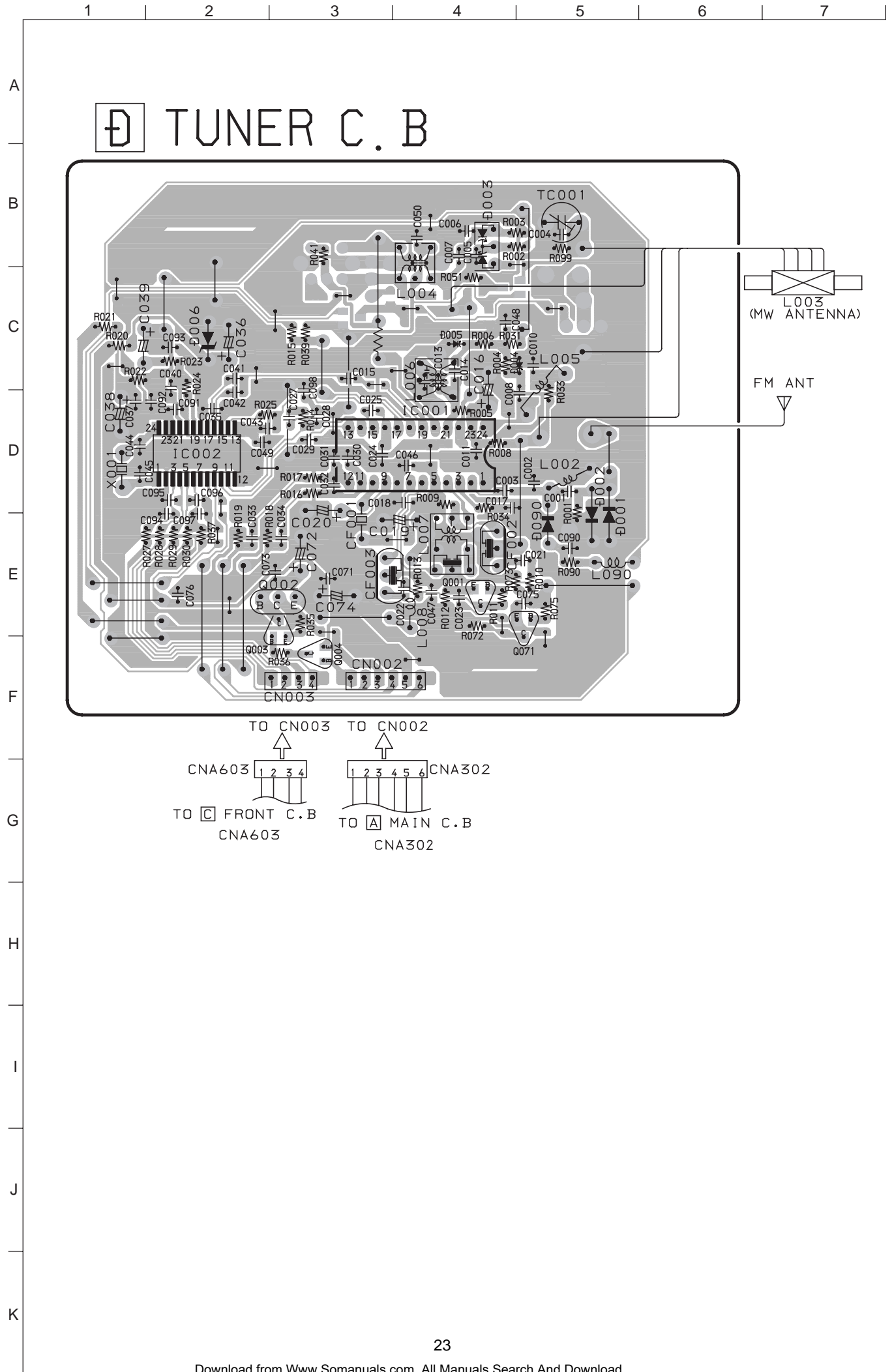

A
B
C
D
E
F
G
H
I
J
K

⊠ TUNER C. B

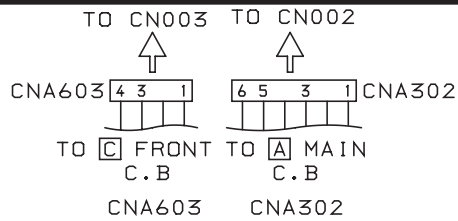
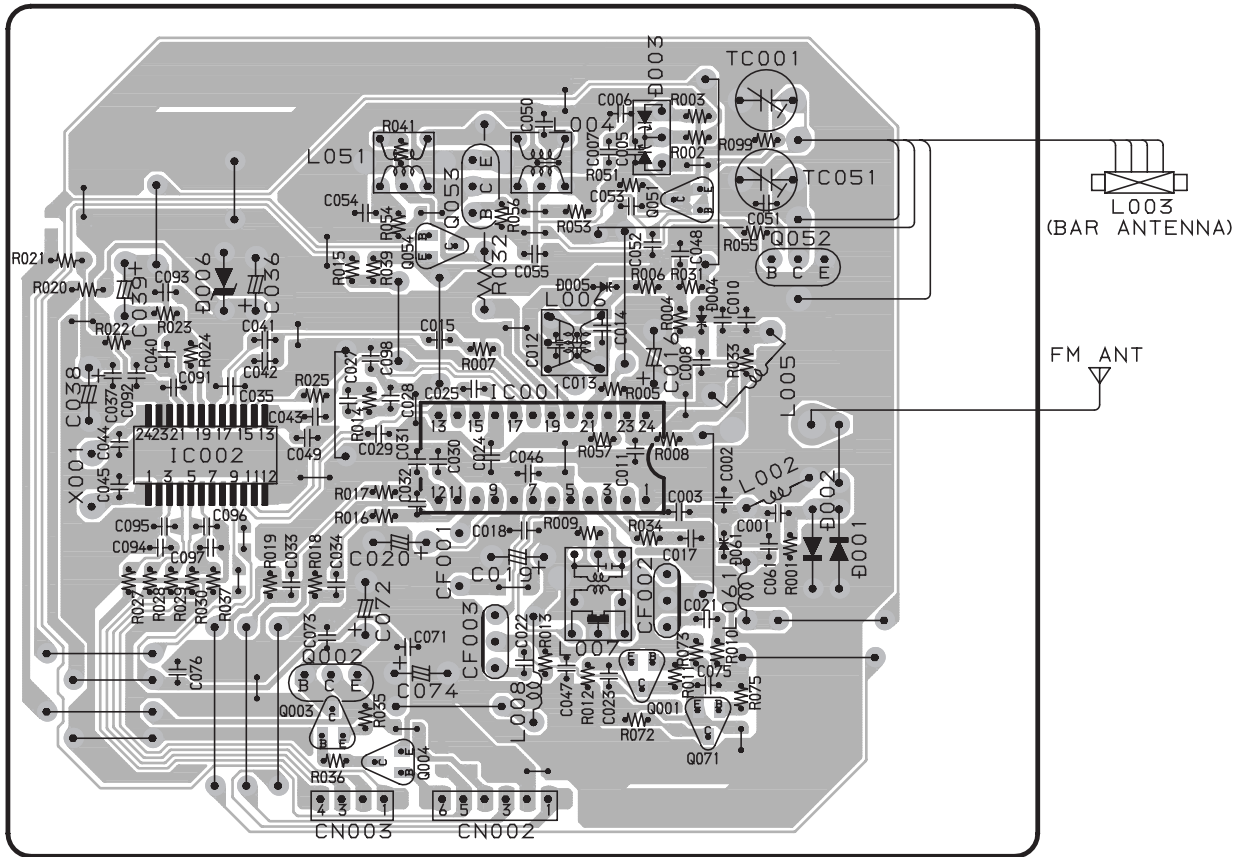

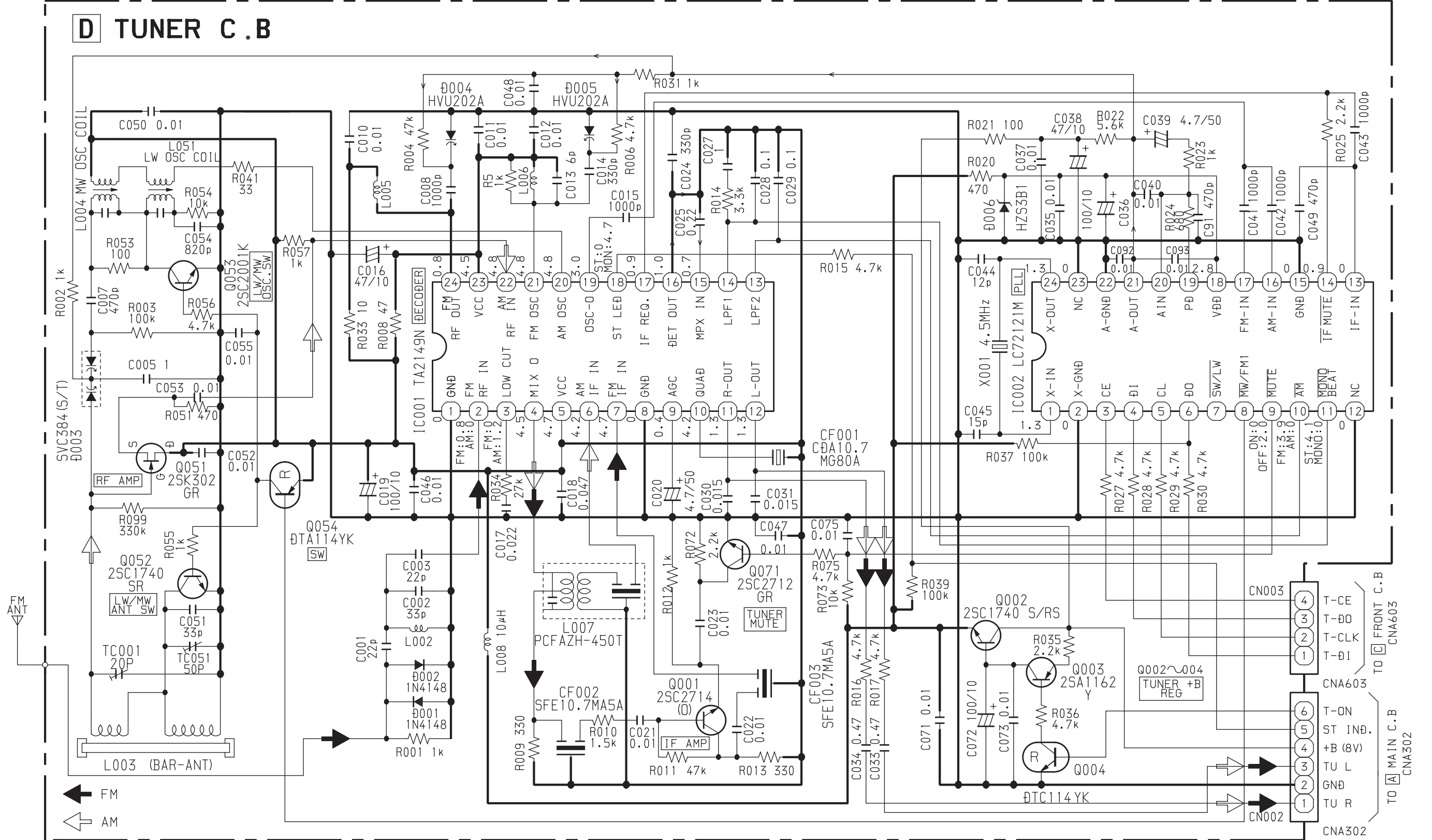

D TUNER C.B

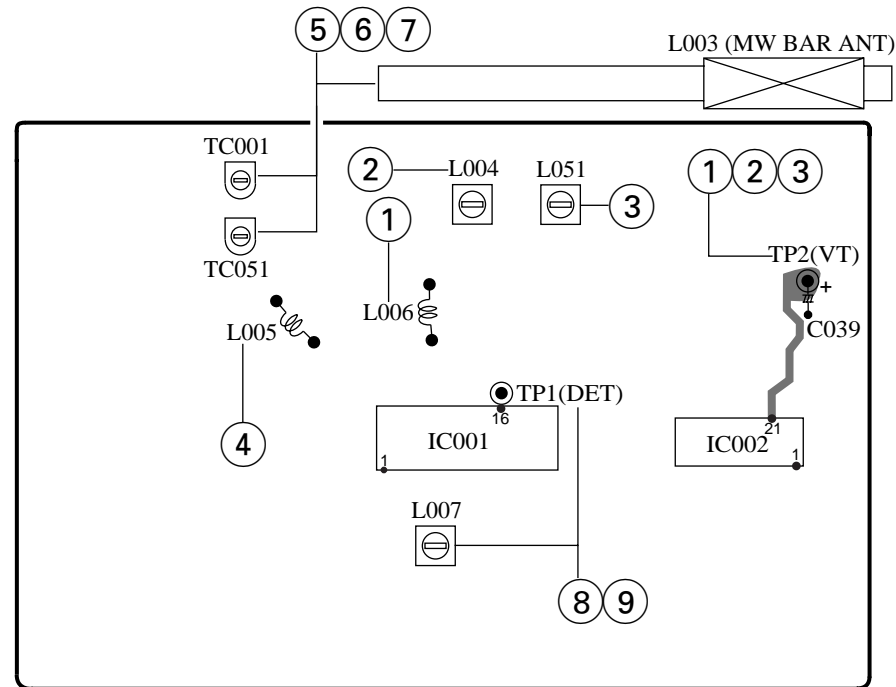

B CD C.B

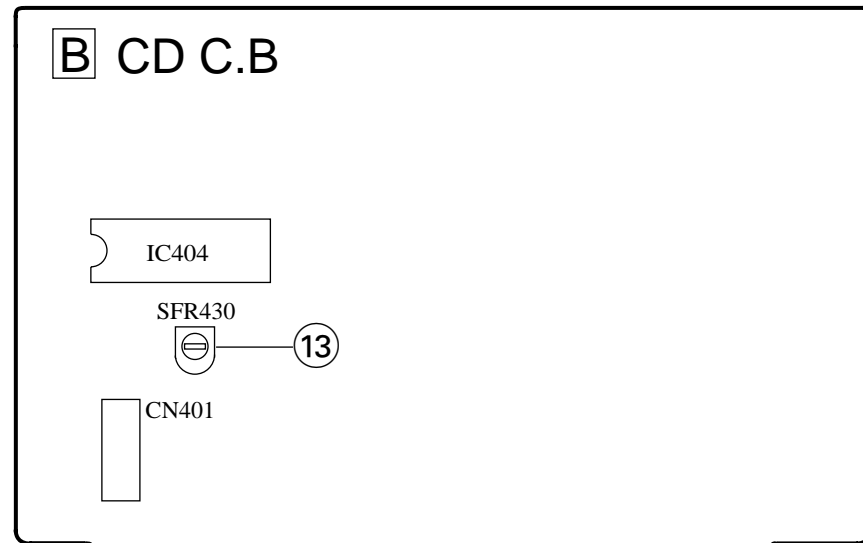

A MAIN C.B

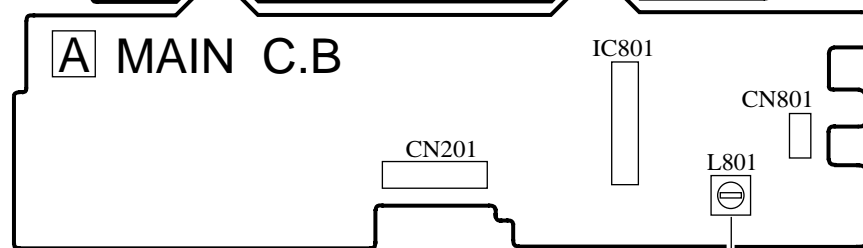

CASSETTE DECK MOTOR

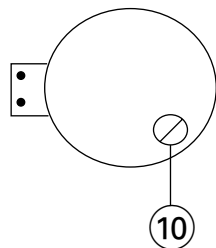

CASSETTE DECK HEAD

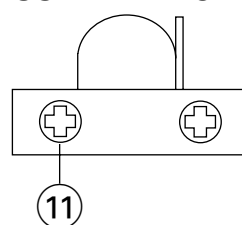

E H.P. C.B

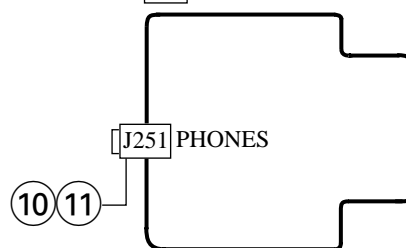

< TUNER SECTION >

1. FM VT Adjustment
 Settings : • Test point : TP2 (VT)
 • Adjustment location : L006
 Method : Set to FM 108.0MHz and adjust L006 so that the test point voltage becomes 6.0V ± 0.05V.
2. MW VT Adjustment
 Settings : • Test point : TP2 (VT)
 • Adjustment location : L004
 Method : Set to MW 1000kHz (U), MW 999kHz (EZ,K) and adjust L004 so that the test point voltage becomes 3.75V ± 0.05V.
3. LW VT Adjustment <EZ,K>
 Settings : • Test point : TP2 (VT)
 • Adjustment location : L051
 Method : Set to LW 288kHz and adjust L051 so that the test point voltage becomes 4.5V ± 0.05V.
4. FM Tracking Adjustment
 L005.....98.0MHz
5. MW Tracking Adjustment <U>
 L003.....600kHz
 TC001.....1400kHz
6. MW Tracking Adjustment <EZ,K>
 L003.....603kHz
 TC001.....1404kHz
7. LW Tracking Adjustment <EZ,K>
 L003.....153kHz
 TC051.....288kHz
8. AM IF Adjustment <U>
 Settings : • Test point : TP1 (DET)
 • Adjustment location : L007
 Method : Adjust L007 so that the output level at 1400kHz becomes maximum.
9. AM IF Adjustment <EZ,K>
 Settings : • Test point : TP1 (DET)
 • Adjustment location : L007
 Method : Adjust L007 so that the output level at 1404kHz becomes maximum.

< DECK SECTION >

10. Tape Speed Adjustment
 Settings : • Test tape : TTA-100
 • Test point : J251 (PHONES jack)
 • Adjustment location : SFR of deck motor
 Method : Play back the test tape and adjust SFR so that the frequency counter reads 3000Hz ± 30Hz.
11. Head Azimuth Adjustment
 Settings : • Test tape : TTA-320
 • Test point : J251 (PHONES jack)
 • Adjustment location : Azimuth adjustment screw
 Method : Play back the 8kHz signal of the test tape and adjust screw so that the output becomes maximum.

12. Bias frequency Adjustment
 L801.....85kHz±0.5kHz

< CD SECTION >

13. FE Balance Adjustment
 Settings : • Test point : IC401 PIN58 (VR), IC401 PIN 20 (FE)
 • Adjustment location : SFR430
 Method : Playback the disc and adjust SFR430 so that the test point voltage becomes 0V.

PRACTICAL SERVICE FIGURE

< TUNER SECTION >

< FM SECTION >

Sensitivity:	Less than 18dB (87.5MHz)
(THD 3%)	Less than 18dB (98.0MHz)
	Less than 18dB (108.0MHz)
Signal to Noise Ratio:	More than 66dB (at 98.0MHz)
(Input 60dB)	(EXCEPT U)
	More than 58dB (at 98.0MHz)
	(U)
Distortion:	Less than 3% (at 98.0MHz)
(Input 60dB)	
Intermediate frequency:	10.7MHz
Stereo separation:	More than 20dB

< AM SECTION >

Sensitivity:	Less than 48dB (at 600kHz)
(S/N 10dB)	Less than 46dB (at 1000kHz)
	Less than 44dB (at 1400kHz)
Distortion:	Less than 3%
(Input 74dB)	
Intermediate frequency:	450kHz

< LW SECTION >

Sensitivity:	Less than 60dB (at 153kHz)
(S/N 10dB)	Less than 56dB (at 198kHz)
	Less than 52dB (at 288kHz)
Distortion:	Less than 3%
(Input 80dB)	
Intermediate frequency:	450kHz

< CASSETTE SECTION >

Tape speed:	3000Hz±60Hz
Wow & flutter:	Less than 0.3% (JIS RMS)
Take-up torque:	30-60g-cm (FWD)
FF torque:	55-140g-cm
Rew torque:	55-140g-cm
S/N ratio:	More than 35dB
Distortion:	Less than 3.0% (PB)
Noise (PB):	Less than 1mV (AC/DC, MIN)
Erasing Ratio (W/FILTER):	More than 45dB

IC DESCRIPTION

IC, LA9241ML

Pin No.	Pin Name	I/O	Description
1	FIN2	I	Pin to which external pickup photo diode is connected. RF signal is created by adding with the FIN1 pin signal. FE signal is created by subtracting from the FIN1 pin signal.
2	FIN1	I	Pin to which external pickup photo diode is connected.
3	E	I	Pin to which external pickup photo diode is connected. TE signal is created by subtracting from the F pin signal.
4	F	I	Pin to which external pickup photo diode is connected.
5	TB	I	DC component of the TE signal is input.
6	TE-	I	Pin to which external resistor setting the TE signal gain is connected between the TE pin.
7	TE	O	TE signal output pin.
8	TESI	I	TES "Track Error Sense" comparator input pin. TE signal is passed through a band-pass filter then input.
9	SCI	I	Shock detection signal input pin.
10	TH	I	Tracking gain time constant setting pin.
11	TA	O	TA amplifier output pin.
12	TD-	I	Pin to which external tracking phase compensation constants are connected between the TD and VR pins.
13	TD	I	Tracking phase compensation setting pin.
14	JP	I	Tracking jump signal (kick pulse) amplitude setting pin.
15	TO	O	Tracking control signal output pin.
16	FD	O	Focusing control signal output pin.
17	FD-	I	Pin to which external focusing phase compensation constants are connected between the FD and FA pins.
18	FA	I	Pin to which external focusing phase compensation constants are connected between the FD- and FA- pins.
19	FA-	I	Pin to which external focusing phase compensation constants are connected between the FA and FE pins.
20	FE	O	FE signal output pin.
21	FE-	I	Pin to which external FE signal gain setting resistor is connected between the FE pin.
22	AGND	—	Analog signal GND.
23	SP	O	Signal ended output of the CV+ and CV- pin input signal.
24	SPI	I	Spindle amp input.
25	SPG	I	Pin to which external spindle gain setting resistor in 12 cm mode is connected.
26	SP-	I	Pin to which external spindle phase compensation constants are connected together with SPD pin.
27	SPD	O	Spindle control signal output pin.
28	SLEQ	I	Pin to which external sled phase compensation constants are connected.
29	SLD	O	Sled control signal output pin.
30, 31	SL-, SL+	I	Sled advance signal input pin from microprocessor.
32, 33	JP-, JP+	I	Tracking jump signal input pin from DSP.
34	TGL	I	Tracking gain control signal input from DSP. Low gain when TGL = H.
35	TOFF	I	Tracking off control signal input pin from DSP. Off when TOFF = H.

Pin No.	Pin Name	I/O	Description
36	TES	O	Pin from which TES signal is output to DSP.
37	HFL	O	“High Frequency Level” is used to judge whether the main beam position is on top of bit or on top of mirror.
38	SLOF	I	Sled servo off control input pin.
39, 40	CV-, CV+	I	CLV error signal input pin from DSP.
41	RFSM	O	RF output pin.
42	RFS-	I	RF gain setting and EFM signal 3T compensation constant setting pin together with RFSM pin.
43	SLC	O	“Slice Level Control” is the output pin which controls the RF signal data slice level by DSP.
44	SLI	I	Input pin which control the data slice level by the DSP.
45	DGND	—	Digital system GND.
46	FSC	O	Output pin to which external focus search smoothing capacitor is connected.
47	TBC	I	“Tracking Balance Control” EF balance variable range setting pin.
48	NC	—	No connection.
49	DEF	O	Disc defect detector output pin.
50	CLK	I	Reference clock input pin. 4.23 MHz of the DSP is input.
51	CL	I	Microprocessor command clock input pin.
52	DAT	I	Microprocessor command data input pin.
53	CE	I	Microprocessor command chip enable input pin.
54	DRF	O	“Detect RF” RF level detector output.
55	FSS	I	“Focus Search Select” focus search mode (\pm search/+ search) select pin.
56	VCC2	—	Servo system and digital system Vcc pin.
57	REFI	—	Pin to which external bypass capacitor for reference voltage is connected.
58	VR	O	Reference voltage output pin.
59	LF2	I	Disc defect detector time constant setting pin.
60	PH1	I	Pin to which external capacitor for RF signal peak holding is connected.
61	BH1	I	Pin to which external capacitor for RF signal bottom holding is connected.
62	LDD	O	APC circuit output pin.
63	LDS	I	APC circuit input pin.
64	VCC1	—	RF system Vcc pin.

IC, LC78622ED

Pin No.	Pin Name	I/O	Description	
1	DEFI	I	Defect sense signal (DEF) input pin. (Connect to 0V when not used).	
2	TAI	I	For PLL.	Test signal input pin with built-in pull-down resistor. Be sure to connect to 0V.
3	PDO	O		Phase comparator output pin to control external VCO.
4	VVSS	—		GND pin for built-in VCO. Be sure to connect to 0V.
5	ISET	I		Pin to which external resistor adjusting the PDO output current.
6	VVDD	—		Power supply pin for built-in VCO.
7	FR	I		Pin for VCO frequency range adjustment.
8	VSS	—	Digital system GND. Be sure to connect to 0V.	
9	EFMO	O	For slice level control.	EFM signal output pin.
10	EFMIN	I		EFM signal input pin.
11	T2	I	Test signal input pin with built-in pull-down resistor. Be sure to connect to 0V.	
12, 13	CLV+, CLK-	O	Disc motor control output. Three level output is possible using command.	
14	$\overline{V/P}$	O	Rough servo or phase control automatic selection monitoring output pin. Rough servo at H. Phase servo at L.	
15	HFL	I	Track detect signal input pin. Schmidt input.	
16	TES	I	Tracking error signal input pin. Schmidt input.	
17	TOFF	O	Tracking OFF output pin.	
18	TGL	O	Tracking gain selection output pin. Gain boost at L.	
19, 20	JP+, JP-	O	Track jump control signal output pin. Three level output is possible using command.	
21	PCK	O	EFM data playback clock monitoring pin 4.3218 MHz when phase is locked in.	
22	FSEQ	O	Sync signal detection output pin. H when the sync signal which is detected from EFM signal and the sync signal which is internally generated agree.	
23	VDD	—	Digital system power supply pin.	
24	SL+	O	Moves the sled to outer circumference.	
25	SL-	O	Moves the sled to inner circumference.	
26	CONT3 (NC)	—	Not connected.	
27	PUIN	I	CD pickup inner switch detection.	
28	\overline{RW}	O	Read, write signal.	
29	EMPH	O	De-emphasis monitor output pin. De-emphasis disc is being played back at H.	
30	C2F	O	C2 flag output pin.	
31	DOUT	O	DIGITAL OUT output pin. (EIAJ format).	
32, 33	T3, T4	I	Test signal input pin with built-in pull-down resistor. Be sure to connect to 0V.	
34	N.C.	—	Not used. Set the pin to open.	
35	MUTEL	O	L-channel 1-bit DAC.	L-channel mute output pin.
36	LVDD	—		L-channel power supply pin.
37	LCHO	O		L-channel output pin.
38	LVSS	—		L-channel GND. Be sure to connect to 0V.
39	RVSS	—	R-channel 1-bit DAC.	R-channel GND. Be sure to connect to 0V.
40	RCHO	O		R-channel output pin.
41	RVDD	—		R-channel power supply pin.
42	MUTER	O		R-channel mute output pin.

Pin No.	Pin Name	I/O	Description
43	XVDD	—	Crystal oscillator power supply pin.
44	XOUT	O	Pin to which external 16.9344 MHz crystal oscillator is connected.
45	XIN	I	
46	XVSS	—	Crystal oscillator GND pin. Be sure to connect to 0V.
47	SBSY	O	Subcode block sync signal output pin.
48	EFLG	O	C1, C2, single and dual correction monitoring pin.
49	PW	O	Subcode P, Q, R, S, T, U and W output pin.
50	SFSY	O	Subcode frame sync signal output pin. Falls down when subcode enters standby.
51	SBCK	I	Subcode read clock input pin. Schmidt input. (Be sure to connected to 0V when not in use.)
52	FSX	O	Pin outputting the 7.35 kHz sync signal which is generated by dividing frequency of crystal oscillator.
53	WRQ	O	Subcode Q output standby output pin.
54	RWC	I	Read/write control input pin. Schmidt input.
55	SQOUT	O	Subcode Q output pin.
56	COIN	I	Command input pin from microprocessor.
57	$\overline{\text{CQCK}}$	I	Command input read clock or subcode read input clock from SQOUT pin
58	RES	I	LC78622 reset input pin. Set this pin to L once when the main power is turned on.
59	T11	O	Test signal output pin. Use this pin as open (normally L output).
60	16M	O	16.9344 MHz output pin.
61	4.2M	O	4.2336 MHz output pin.
62	T5	I	Test signal input pin with built-in pull-down resistor. Be sure to connect to 0V.
63	$\overline{\text{CS}}$	I	Chip select signal input pin with built-in pull-down resistor. Be sure to connect to 0V while it is not controlling.
64	T1	I	Test signal input pin without built-in pull-down resistor. Be sure to connect to 0V.

IC, LC867132V-5P07

Pin No.	Pin Name	I/O	Description
1	O-RMC/CE	O	CD read/write control output and TU CE.
2	O-DATA	O	Data output to M62495FP.
3	O-CLK	O	Output CLK to tuner PLL.(Not connected)
4	—	—	Not Connected.
5	O-CLK SFT	O	Clock shift output of the microcomputer.
6	I-HOLD	I	Hold status detection.
7	RST	I	Microcomputer reset.
8	XT1 (IN)	I	Connected to 32.768KHZ crystal oscillator.
9	XT2 (OUT)	O	
10	VSS1	—	GND.
11	CF1 (IN)	I	Connected to 6MHZ Ceramic Filter.
12	CF2 (OUT)	O	
13	VDD1	—	Power supply for microcomputer (+5V).
14	I-ST IND	I	FM STEREO status input.
15	I-KEYO	I	KEY AD input.
16	I-CD SW	I	CD DOOR SW status detection input.
17	I-KEY1	I	KEY AD input.
18	I-MOTOR	I	DECK MECHA MOTOR status input.
19	I-REC	I	REC status input.
20	I-FM/AM	I	FM, AM status input. (Not connected)
21	I-TU DO	I	Data input from tuner PLL.(Not connected)
22	O-BASS LED	O	BASS LED ON/OFF control output.
23	O-QS LED	O	Q-Sound LED ON/OFF control output.
24	O-DUBB LED	O	LED control output used for high-speed dubbing.
25	O-INT	O	INT DIODE MATRIX detection output.(Not connected)
26	I-DRF	I	CD RF level detection input.
27	I-WRQ	I	CD sub-code Q standby input.
28	I-REMO	I	Remote control input.
29	S0/PA0	O	LCD segment output.
30	S1/PA1	O	LCD segment output.
31	S2/PA2	O	LCD segment output.
32	S3/PA3	O	LCD segment output.
33	S4/PA4	O	LCD segment output.
34	S5/PA5	O	LCD segment output.
35	S6/PA6	O	LCD segment output.
36	S7/PA7	O	LCD segment output.
37-40	S8-S11	O	
41	VDD3	—	Power supply for microcomputer (+5V).
42	VSS3	—	GND.
43, 44	S12, S13	O	LCD segment output.
45-50	S14- S19	O	LCD segment output.

Pin No.	Pin Name	I/O	Description
51-54	S20- S23	—	Not connected.
55	O-CD LED	O	LED ON/OFF control output for CD functions.
56	O-TU LED	O	LED ON/OFF control output for TU functions.
57	O-TA LED	O	LED ON/OFF control output for TAPE functions. (Not Connected)
58	O-ROCK LED	O	LED ON/OFF control output for ROCK.
59	O-POP LED	O	LED ON/OFF control output for POP.
60	O-JAZZ LED	O	LED ON/OFF control output for JAZZ.
61	—	—	Not connected.
62	I-CD TEST	—	Not connected.
63	I-TU TEST	—	Not connected.
64-66	COM0-COM2	O	LCD common output.
67	—	—	Not connected.
68	VSS2	—	GND.
69	VDD2	—	Power supply for microcomputer (+5V).
70	O-CD ON	O	CD PWR control output.
71	O-TU ON	O	TU PWR control output.
72	O-P.CONT	O	Power supply control output.
73	$\overline{\text{O-H.DUBB}}$	O	Dubbing speed control output.
74	O-MUTE	O	Main mute output.
75	O-MO/ST	O	FM mono/stereo output.
76	O-BEAT CONT	O	BEAT switch over output.
77	O-QSOUND	O	Q-Sound ON/OFF output.
78	O-COIN	O	CD command output.
79	I-SQOUT	I	CD sub-code Q input.
80	O-CQCK	O	CLK for CD commands/sub-codes.

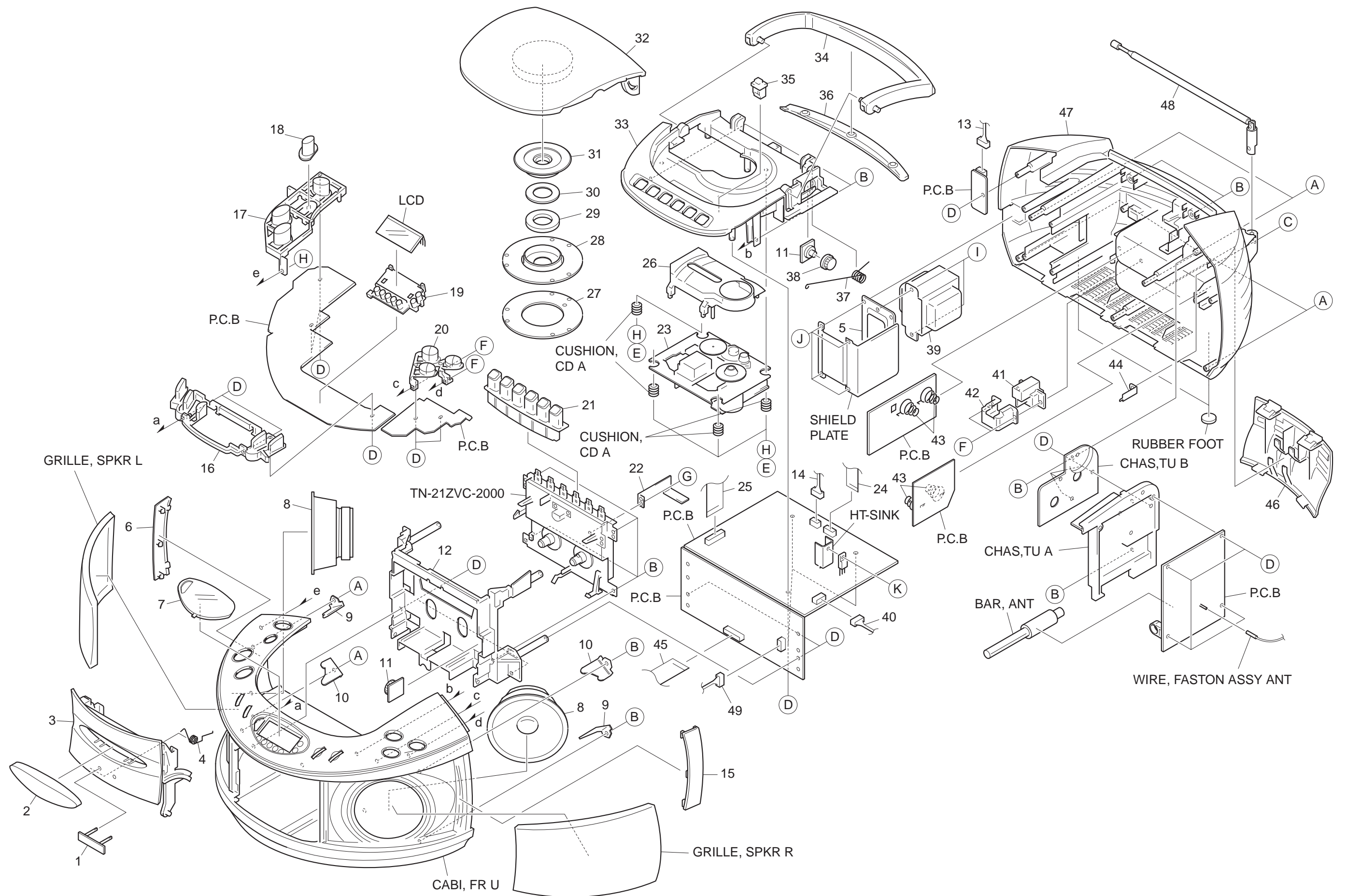

MECHANICAL PARTS LIST 1/1

DESCRIPTIONで判断できない物は "REFERENCE NAME LIST" を参照してください。
 If can't understand for Description please kindly refer to "REFERENCE NAME LIST".

REF. NO	PART NO.	KANRI NO.	DESCRIPTION	REF. NO	PART NO.	KANRI NO.	DESCRIPTION
1	8Z-CL7-107-010		BADGE,AIWA SILVER	32	8A-CH8-037-010		BOX,CD (L)<53 U<L>>
2	8A-CD8-007-010		WINDOW,CASS<EXCEPT 53 U<L>,52 U<W>>	32	8A-CH8-018-010		BOX,CD (W)<52 U<W>>
2	8A-CH8-040-010		WINDOW,CASS (L)<53 U<L>>	32	8A-CD8-027-010		BOX,CD EX<EXCEPT 53 U<L>,52 U<W>>
2	8A-CH8-021-010		WINDOW,CASS (W)<52 U<W>>	33	8A-CH8-038-010		CHAS,CD (L)<53 U<L>>
3	8A-CD8-006-010		BOX,CASS<EXCEPT 53 U<L>,52 U<W>>	33	8A-CH8-019-010		CHAS,CD (W)<52 U<W>>
3	8A-CH8-039-010		BOX,CASS (L)<53 U<L>>	33	8A-CD8-028-010		CHAS,CD EX<EXCEPT 53 U<L>,52 U<W>>
3	8A-CH8-020-010		BOX,CASS (W)<52 U<W>>	34	8A-CD8-008-010		HANDL,FR<EXCEPT 53 U<L>,52 U<W>>
4	8A-CD8-207-010		SPR-T,CASS	34	8A-CH8-041-010		HANDL,FR (L)<53 U<L>>
5	8A-CD8-209-010		HLDR,TRANS	34	8A-CH8-022-010		HANDL,FR (W)<52 U<W>>
6	8A-CD8-018-010		PANEL,FR L<EXCEPT 53 U<L>,52 U<W>>	35	87-036-389-010		SW,PUSH LOCK
6	8A-CH8-048-010		PANEL,FR L (L)<53 U<L>>	36	8A-CD8-009-010		HANDL,REAR<EXCEPT 53 U<L>,52 U<W>>
6	8A-CH8-029-010		PANEL,FR L (W)<52 U<W>>	36	8A-CH8-023-010		HANDL,REAR (W)<52 U<W>>
7	8A-CH8-014-010		WINDOW,LCD EX<51 K<S>,51 EZ<S>>	37	8A-CD8-208-010		SPR-T,CD
7	8A-CH8-003-010		WINDOW,LCD U<51 U<S>,53 U<L>,52 U<W>>	38	84-CD5-216-010		BRACKET
8	88-CD8-622-010		SPKR,F 77 70HM 3W	39	8A-CD8-603-010		PT,E 2.5W<51 K<S>,51 EZ<S>>
9	8A-CD8-210-010		HLDR,SPKR A	39	8A-CD8-602-010		PT,U 2.5W<51 U<S>,53 U<L>,52 U<W>>
10	8A-CD8-211-010		HLDR,SPKR B	40	8A-CD9-630-010		CONN ASSY,4P RPH
11	84-CD5-215-010		GEAR	41	87-A60-178-010		JACK,AC E W/SW<51 K<S>,51 EZ<S>>
12	8A-CD8-021-010		CHAS,CASS<EXCEPT 53 U<L>,52 U<W>>	41	87-A60-177-010		JACK,AC U W/SW<51 U<S>,53 U<L>,52 U<W>>
12	8A-CH8-047-010		CHAS,CASS (L)<53 U<L>>	42	87-A90-086-010		COVER,AC-SOCKET
12	8A-CH8-031-010		CHAS,CASS (W)<52 U<W>>	43	88-CD8-209-010		SPR-C,BATT
13	8A-CD9-633-010		CONN ASSY,4P SP	44	8A-CD8-212-010		HLDR,ANT
14	8A-CD9-626-010		CONN ASSY,2P DOOR	45	8A-CD9-620-010		FF-CABLE, 16P FR-MAIN
15	8A-CD8-022-010		PANEL,FR R<EXCEPT 53 U<L>,52 U<W>>	46	8A-CD8-003-010		LID,BATT<EXCEPT 53 U<L>,52 U<W>>
15	8A-CH8-049-010		PANEL,FR R (L)<53 U<L>>	46	8A-CH8-036-010		LID,BATT (L)<53 U<L>>
15	8A-CH8-030-010		PANEL,FR R (W)<52 U<W>>	46	8A-CH8-017-010		LID,BATT (W)<52 U<W>>
16	8A-CH8-005-010		KEY,CONTROL CD<EXCEPT 53 U<L>,52 U<W>>	47	8A-CH8-002-010		CABI,REAR<EXCEPT 53 U<L>,52 U<W>>
16	8A-CH8-046-010		KEY,CONTROL CD (L)<53 U<L>>	47	8A-CH8-035-010		CABI,REAR (L)<53 U<L>>
16	8A-CH8-027-010		KEY,CONTROL CD (W)<52 U<W>>	47	8A-CH8-016-010		CABI,REAR U (W)<52 U<W>>
17	8A-CD8-014-010		KEY,VOL<EXCEPT 53 U<L>,52 U<W>>	48	8Z-CH4-640-010		ANT,ROD
17	8A-CH8-044-010		KEY,VOL (L)<53 U<L>>	49	8A-CD9-631-010		CONN ASSY,4P TP-ME
17	8A-CH8-025-010		KEY,VOL (W)<52 U<W>>	A	87-B10-242-010		UT2+3-30 W/O CR
18	8A-CD8-017-010		KEY,QSOUND	B	87-641-096-410		UT1+3-10 GLD
19	8A-CH8-201-010		HLDR,LCD	C	87-254-097-410		U+3-12 CR
20	8A-CH8-004-010		KEY,FUNC<EXCEPT 53 U<L>,52 U<W>>	D	87-741-095-410		UT2+3-8 GLD
20	8A-CH8-045-010		KEY,FUNC (L)<53 U<L>>	E	87-342-074-010		UT2+2.6-8
20	8A-CH8-026-010		KEY,FUNC (W)<52 U<W>>	F	87-353-076-210		VT2+2.6-12
21	8A-CH8-043-010		KEY,CASS (L)<53 U<L>>	G	87-571-032-410		VIT+2-3
21	8A-CH8-024-010		KEY,CASS (W)<52 U<W>>	H	87-WA5-253-010		W,3.3-10-0.8
21	8A-CD8-011-010		KEY,CASS SET<EXCEPT 53 U<L>,52 U<W>>	I	87-751-094-410		VT2+3-6 W10SLOT
22	8A-CD8-213-010		SPR-P,REC	J	87-661-097-410		TAPPING SCREW, VFT1+3-12
23	M8-ZZK-E90-070		DA11T3C	k	87-067-566-010		TAPPING SCREW, VFTT+3-6
24	8A-CD9-622-010		FF-CABLE, 8P CD-FR				
25	8A-CD9-621-010		FF-CABLE, 16P CD-RF				
26	8Z-CDB-169-010		PANEL,CD SANYO				
27	88-CD9-211-210		RING,CHUCK				
28	8Z-CDB-170-010		BASE,CHUCK				
29	87-036-368-010		MAGNET				
30	84-CT5-209-010		PLATE,MAGNET				
31	8Z-CH4-225-110		HLDR,CHUCK A(S)				

COLOR NAME TABLE

Basic color symbol	Color	Basic color symbol	Color	Basic color symbol	Color
B	Black	C	Cream	D	Orange
G	Green	H	Gray	L	Blue
LT	Transparent Blue	N	Gold	P	Pink
R	Red	S	Silver	ST	Titan Silver
T	Brown	V	Violet	W	White
WT	Transparent White	Y	Yellow	YT	Transparent Yellow
LM	Metallic Blue	LL	Light Blue	GT	Transparent Green
LD	Dark Blue	DT	Transparent Orange		

TAPE MECHANISM EXPLODED VIEW 1/1

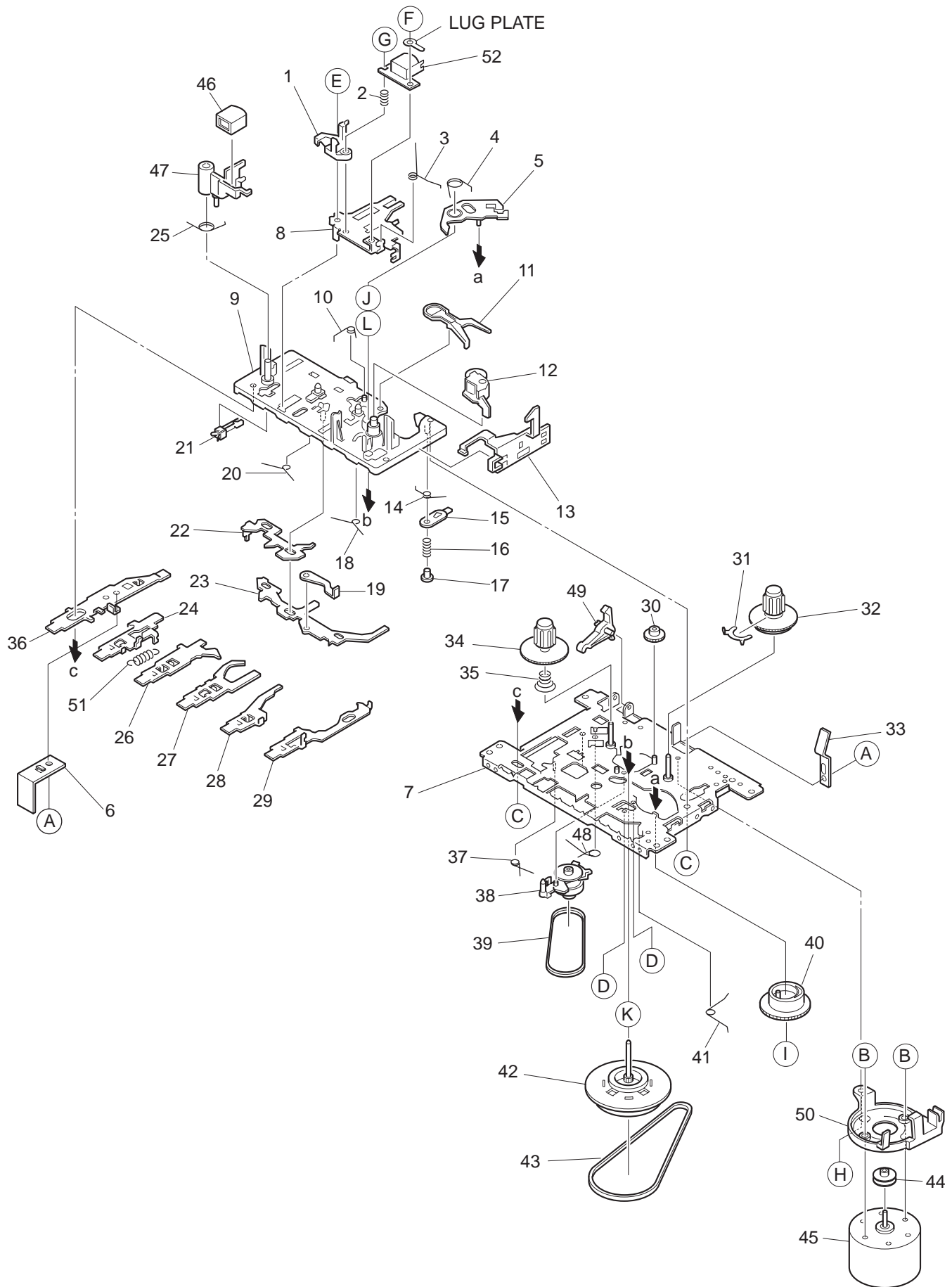

TAPE MECHANISM PARTS LIST 1/1

DESCRIPTIONで判断できない物は "REFERENCE NAME LIST" を参照してください。
If can't understand for Description please kindly refer to "REFERENCE NAME LIST".

REF. NO	PART NO.	KANRI NO.	DESCRIPTION
1	S1-921-030-4A0		HEAD BASE
2	S1-821-030-070		AZIMUTH SPRING
3	S1-921-030-090		PANEL P SPRING
4	S1-921-260-050		GEAR PLATE SPRING
5	S1-921-265-020		GEAR PLATE ASSY
6	S1-510-020-020		REC SPRING PLATE
7	S1-921-015-010		CHASSIS ASSY
8	S1-921-030-110		HEAD PANEL
9	S1-921-143-160		BASE ASSY
10	S1-921-141-8A0		M CONTROL SPRING
11	S1-921-260-4A0		SENSING LEVER
12	S1-921-043-100		PINCH ROLLER ARM ASSY
13	S1-921-130-010		EJECT SLIDE LEVER
14	S1-921-141-3A0		P CONTROL SPRING
15	S1-921-140-550		PAUSE LEVER(E)
16	S1-921-140-120		PAUSE LEVER SPRING
17	S1-921-140-110		PAUSE STOPPER
18	S1-921-140-150		BUTTON LEVER SPRING(B)
19	S1-821-011-590		E KICK LEVER
20	S1-921-141-070		BUTTON LEVER SPRING(A)
21	S6-401-011-490		LEAF SW MSW-1541T
22	S1-921-140-090		SWITCH ACTUATOR
23	S1-921-140-080		PUSH BUTTON ACTUATOR
24	S1-921-140-190		PLAY BUTTON LEVER
25	S1-921-030-100		MG ARM SPRING
26	S1-921-140-040		REW BUTTON LEVER
27	S1-921-140-050		FF,BUTTON REVER
28	S1-921-140-060		STOP BUTTON LEVER
29	S1-921-140-600		PAUSE BUTTON LEVER
30	S1-821-100-700		FF GEAR
31	S1-921-050-060		SENSOR
32	S1-921-053-100		TAKE UP REEL ASSY
33	S1-829-100-010		PACK SPRING
34	S1-921-050-150		S REEL HUB
35	S1-921-050-220		BACK TENSION SPRING
36	S1-921-140-030		REC BUTTON LEVER
37	S1-921-140-170		P.S.LEVER SPRING
38	S1-921-073-040		RF CLUTCH ASSY
39	S1-921-070-030		RF BELT
40	S1-921-260-020		CAM GEAR
41	S1-921-140-160		E ACTUATOR SPRING
42	S1-921-093-210		FLYWHEEL ASSY
43	S1-921-090-380		MAIN BELT
44	S1-921-120-590		MOTOR PULLEY
45	S6-002-030-220		MOTOR EG530AD-2B
46	S6-209-100-100		E HEAD PH-K380-MS1
47	S1-921-030-050		MG ARM
48	S1-921-140-210		REC BUTTON LEVER SPRING
49	S1-821-100-690		RECORD SAFETY LEVER
50	S1-821-128-9A0		MOTOR BRACKET
51	S1-821-010-500		PLAY BUTTON LEVER SPRING
52	S6-201-011-110		HEAD,RP7442ES-0951
A	S9-P04-200-310		C TAPPING SCREW 2-3
B	S1-921-120-020		MOTOR COLLER SCREW
C	S9-B10-200-510		P TAPPING BIND SCREW M2-5
D	S9-C07-204-510		SCREW,TAPPING(CAMERA)M2-4.5
E	S9-P01-200-610		SCREW,M2-6
F	S9-B01-200-310		(+)BIND SCREW M2-3
G	S9-F08-200-710		AZIMUTH SCREW M2-7
H	S1-921-120-030		MB SCREW
I	S9-W02-300-100		P WASHER CUT 1.2-3.8-0.3
J	S9-W02-500-100		P WASHER CUT 1.45-3.8-0.5
K	S9-W01-400-100		P WASHER 2-3.5-0.4
L	S9-W01-130-200		P WASHER 2.1-4-0.13

CD MECHANISM EXPLODED VIEW 1/1

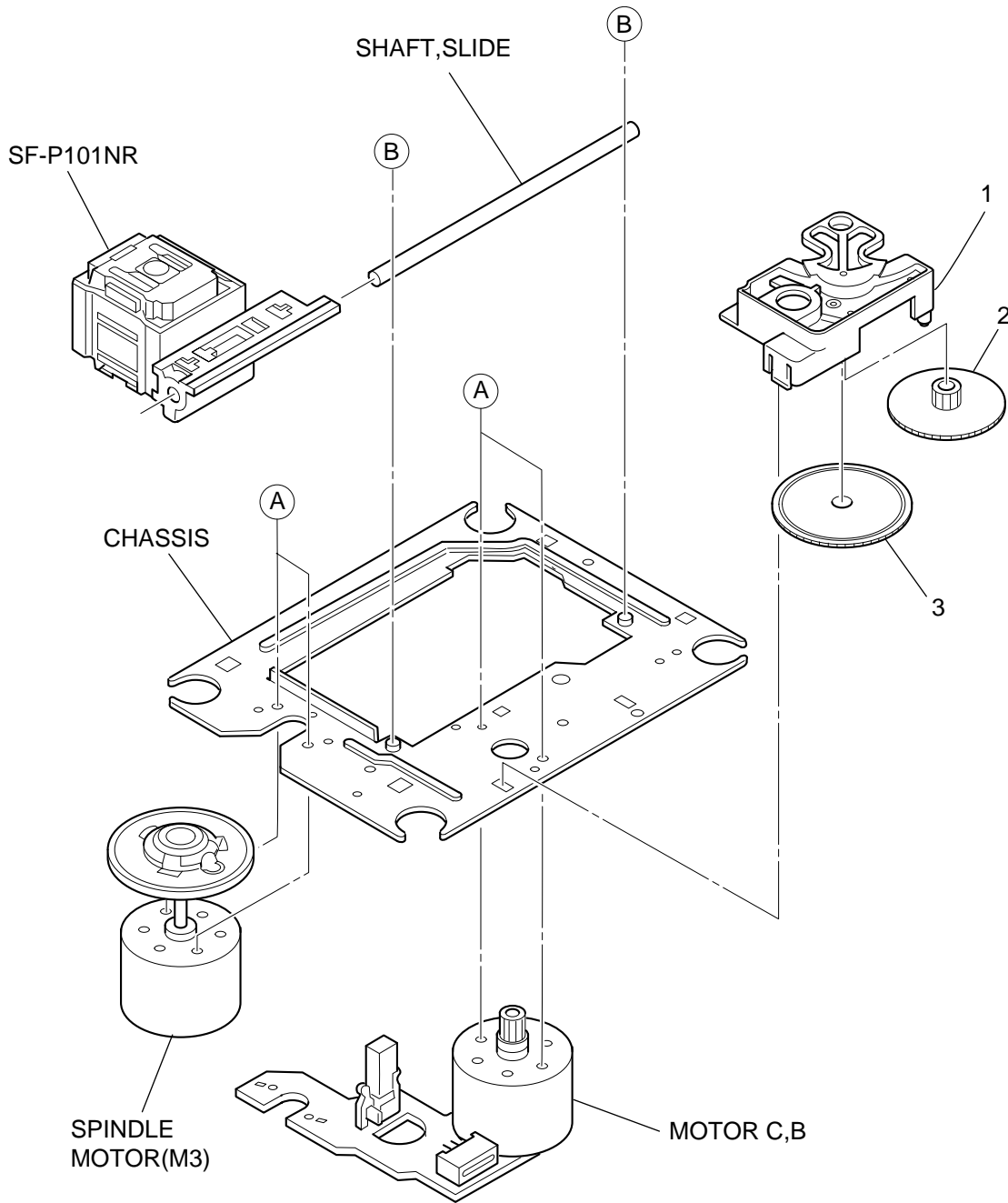

CD MECHANISM PARTS LIST 1/1

DESCRIPTIONで判断できない物は "REFERENCE NAME LIST" を参照してください。
 If can't understand for Description please kindly refer to "REFERENCE NAME LIST".

REF. NO	PART NO.	KANRI NO.	DESCRIPTION
1	S2-121-A28-400		COVER GEAR
2	S2-511-A21-000		GEAR MIDDLE
3	S2-511-A21-100		GEAR, DRIVE
A	S1-PN2-03R-OSE		SCR PAN PCS 2-3
B	87-261-073-410		SCR. S-TPG FLT 2.6-6
ALL	M8-ZZK-E90-070		DA11T3C

ACCESSORIES/PACKAGE LIST

DESCRIPTIONで判断できない物は "REFERENCE NAME LIST" を参照してください。
 If can't understand for Description please kindly refer to "REFERENCE NAME LIST".

REF. NO	PART NO.	KANRI NO.	DESCRIPTION
1	8A-CH8-906-010		IB,EZ(9L)B<51 EZ<S>>
1	8A-CH8-905-010		IB,K(E)B<51 K<S>>
1	8A-CH8-903-010		IB,U(ESF)B<51 U<S>,53 U<L>,52 U<W>>
⚠	2	87-A80-036-010	AC CORD SET ASSY,E W/FLTR VOL<51 EZ<S>>
⚠	2	87-A80-034-010	AC CORD SET ASSY,K W/F MAY-BG<51 K<S>>
⚠	2	87-A80-109-010	AC CORD,HK7281 BLK U<51 U<S>,53 U<L>,52 U<W>>

アイワ株式会社 〒110-8710 東京都台東区池之端1-2-11 ☎03(3827)3111 (代表)
AIWA CO.,LTD. 2-11, IKENOHATA 1-CHOME, TAITO-KU, TOKYO 110, JAPAN TEL:03(3827)3111

Free Manuals Download Website

<http://myh66.com>

<http://usermanuals.us>

<http://www.somanuals.com>

<http://www.4manuals.cc>

<http://www.manual-lib.com>

<http://www.404manual.com>

<http://www.luxmanual.com>

<http://aubethermostatmanual.com>

Golf course search by state

<http://golfingnear.com>

Email search by domain

<http://emailbydomain.com>

Auto manuals search

<http://auto.somanuals.com>

TV manuals search

<http://tv.somanuals.com>