

SERVICE MANUAL

VIDEO CASSETTE RECORDER

BASIC TAPE MECHANISM : OVD-6

SPECIFICATIONS

POWER REQUIREMENTS	230 V AC, 50 Hz	HI-FI WOW AND FLUTTER	Less than 0.01% (nominal)
POWER CONSUMPTION	17W	TAPE SPEED	PAL SP: 23.39 mm/sec
WEIGHT	3.5 kg (7.7 lbs.)		LP: 11.69 mm/sec
DIMENSIONS	380 mm (W) x 267 mm (D) x 95 mm (H)		NTSC (playback only)
	(15 x 10 5/8 x 3 3/4 in.)	RECORDING/PLAYBACK TIME	PAL SP: 5 hours with E-300 tape
OPERATING TEMPERATURE	5°C to 40°C		LP: 10 hours with E-300 tape
VIDEO RECORDING SYSTEM	Rotary 2 head helical scanning system		NTSC (playback only)
VIDEO SIGNAL SYSTEM	PAL colour system, 625 lines, 50 fields		SP: 3 hours 30 minutes with T-210 tape
VIDEO HEAD	Double azimuth 4 heads	VIDEO INPUT	1.0 Vp-p, 75 ohm, unbalanced
USABLE CASSETTES	VHS video cassette	VIDEO OUTPUT	1.0 Vp-p, 75 ohm, unbalanced
CHANNEL COVERAGE	UHF: 21 to 69	VIDEO S/N	53 dB (nominal)
RF OUTPUT	UHF channels between 23 and 69, 73 dBµ	AUDIO INPUT	SCART: -3.8 dBs, 50 Kohm
HORIZONTAL RESOLUTION	240 lines (SP)		RCA: -3.8 dBs, 50 Kohm
TIMER BACKUP	30 minutes	AUDIO OUTPUT	SCART: -3.8 dBs, less than 1 Kohm
TUNER SYSTEM	Frequency synthesized tuner		RCA: -3.8 dBs, less than 1 Kohm
TV SYSTEM	I	AUDIO TRACK	3 tracks (Hi-Fi sound 2 tracks, Normal sound 1 track)
FAST-FORWARD TIME	135 seconds with E-180 tape		
REWIND TIME	108 seconds with E-180 tape		
HI-FI FREQUENCY RESPONSE	20 Hz-20 KHz		
HI-FI DYNAMIC RANGE	More than 75 dB		

● Design and specifications are subject to change without notice.

aiwa
S/M Code No. 09-996-332-2N1



TABLE OF CONTENTS

SPECIFICATIONS	COVER
TABLE OF CONTENTS	A-1
SERVICING NOTICES ON CHECKING	A-2
IMPORTANT NOTICE	A-2
DISASSEMBLY INSTRUCTIONS	
REMOVAL OF MECHANICAL PARTS AND P.C. BOARDS	B1-1
REMOVAL OF DECK PARTS	B2-1~B2-5
KEY TO ABBREVIATIONS	C1-1, C1-2
SERVICE MODE LIST	C2-1
PREVENTIVE CHECKS AND SERVICE INTERVALS	C3-1, C3-2
NOTE FOR THE REPLACING OF MEMORY IC	C4-1
SERVICING FIXTURES AND TOOLS	C5-1
PREPARATION FOR SERVICING	C5-1
VCR TEST TAPE INTERCHANGEABILITY TABLE	C6-1
MECHANICAL ADJUSTMENTS	
CONFIRMATION AND ADJUSTMENT	D1-1, D1-2
CONFIRMATION AND ADJUSTMENT OF TAPE RUNNING MECHANISM	D1-2, D1-3
MECHANISM ADJUSTMENT PARTS LOCATION GUIDE	D1-4
ELECTRICAL ADJUSTMENTS	
BASIC ADJUSTMENTS	D2-1
ELECTRICAL ADJUSTMENT PARTS LOCATION GUIDE	D2-2
TROUBLESHOOTING GUIDES	E-1~E-28
IC DESCRIPTIONS	F-1, F-2
SERVO TIMING CHART	G-1
SYSTEM SWITCH MODE	G-2
SEMICONDUCTOR BASE CONNECTIONS	H-1
BLOCK DIAGRAMS	
Y/C/AUDIO/HEAD AMP	I-1
SYSTEM CONTROL/SERVO/TIMER	I-2
TUNER/HIFI/21PIN/OSD/VPS/NICAM	I-3
OPERATION/POWER	I-4
DECK SCHEMATIC DIAGRAM	J-1
OPERATION SCHEMATIC DIAGRAM	J-2
PRINTED CIRCUIT BOARDS (OPERATION 1/2/DECK)	J-3
PRINTED CIRCUIT BOARDS (SYSCON)	J-4~J-6
Y/C/AUDIO/HEAD AMP SCHEMATIC DIAGRAM	J-7
SYSTEM CONTROL/SERVO/TIMER SCHEMATIC DIAGRAM	J-8
21PIN/OSD/VPS SCHEMATIC DIAGRAM	J-9
TUNER/HIFI SCHEMATIC DIAGRAM	J-10
POWER SCHEMATIC DIAGRAM	J-11
DISPLAY SCHEMATIC DIAGRAM	J-12
NICAM SCHEMATIC DIAGRAM	J-13
INTERCONNECTION DIAGRAM	J-14
WAVEFORMS	K-1
MECHANICAL EXPLODED VIEW	L1-1
MECHANICAL REPLACEMENT PARTS LIST	L2-1
ACCESSORY REPLACEMENT PARTS LIST	L2-1
CHASSIS EXPLODED VIEW (TOP VIEW)	M1-1
CHASSIS EXPLODED VIEW (BOTTOM VIEW)	M1-2
CHASSIS REPLACEMENT PARTS LIST	M2-1
ELECTRICAL REPLACEMENT PARTS LIST	N-1~N-3

SERVICING NOTICES ON CHECKING

1. KEEP THE NOTICES

As for the places which need special attentions, they are indicated with the labels or seals on the cabinet, chassis and parts. Make sure to keep the indications and notices in the operation manual.

2. USE THE DESIGNATED PARTS

The parts in this equipment have the specific characters of incombustibility and withstand voltage for safety. Therefore, the part which is replaced should be used the part which has the same character.

Especially as to the important parts for safety which is indicated in the circuit diagram or the table of parts as a \triangle mark, the designated parts must be used.

3. PUT PARTS AND WIRES IN THE ORIGINAL POSITION AFTER ASSEMBLING OR WIRING

There are parts which use the insulation material such as a tube or tape for safety, or which are assembled in the condition that these do not contact with the printed board. The inside wiring is designed not to get closer to the pyrogenic parts and high voltage parts. Therefore, put these parts in the original positions.

4. PERFORM A SAFETY CHECK AFTER SERVICING

Confirm that the screws, parts and wiring which were removed in order to service are put in the original positions, or whether there are the portions which are deteriorated around the serviced places serviced or not. Check the insulation between the antenna terminal or external metal and the AC cord plug blades. And be sure the safety of that.

IMPORTANT NOTICE

The remote control for this model can be selected the Custom code 1 and Custom code 2.

• How to selection;

Custom code 1 : Press the Power key and 1 key on the remote control simultaneously for more than 2 seconds.

Custom code 2 : Press the Power key and 2 key on the remote control simultaneously for more than 2 seconds.

The Custom code 1 is only available for the VCR unit but the Custom code 2.

When selected the Custom code 2 by mistake, just remove the batteries from the remote control for the moment or select the Custom code 1 as described above.

DISASSEMBLY INSTRUCTIONS

1. REMOVAL OF MECHANICAL PARTS AND P.C. BOARDS

1-1: TOP CABINET, FRONT CABINET AND OPERATION 1, 2 PCB (Refer to Fig. 1-1)

1. Remove the 4 screws ①.
2. Remove the Top Cabinet in the direction of arrow (A).
3. Disconnect the following connectors: (CP651 and CP652).
4. Unlock the 7 supports ②.
5. Remove the Front Cabinet in the direction of arrow (B).
6. Remove the 3 screws ③ and remove the Operation 1 PCB.
7. Remove the 4 screws ④ and remove the Operation 2 PCB.

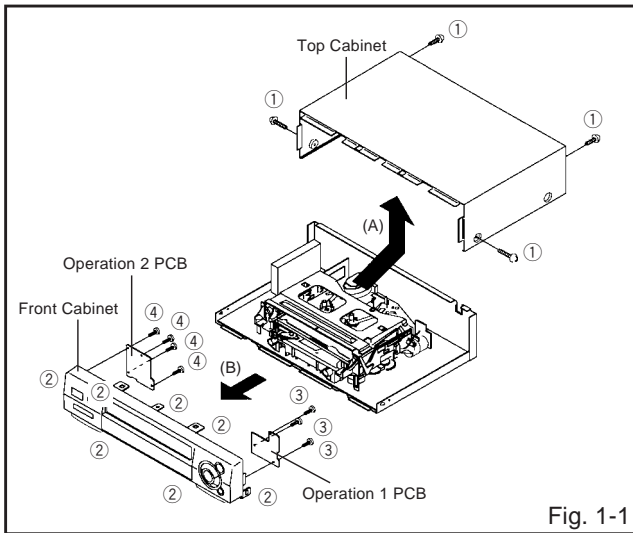

1-2: FLAP (Refer to Fig. 1-2)

1. Open Flap to 90° and flex in direction of arrow (A), at the same time slide in direction of arrow (B).
2. Then lift in direction of arrow (C).

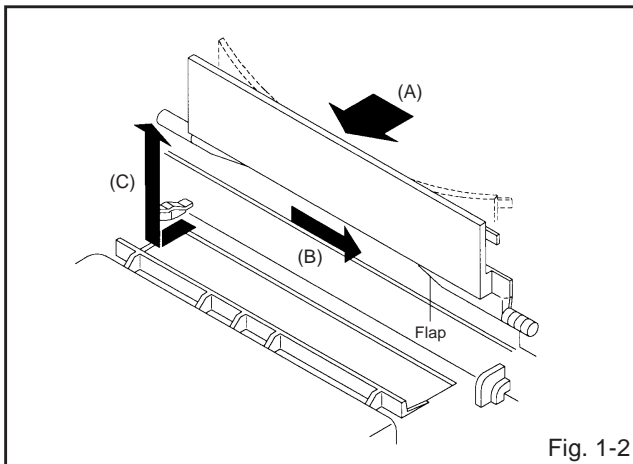

1-3: DECK CHASSIS (Refer to Fig. 1-3)

1. Remove the 3 screws ①.
2. Remove the screw ②.
3. Disconnect the following connectors: (CP1001, CP1002, CP1004, CP4001, CP4002 and CP4003).
4. Remove the Deck Chassis in the direction of arrow.

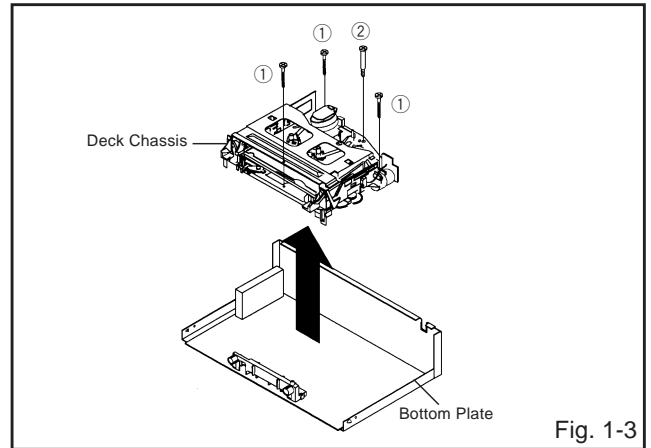

1-4: SYSCON PCB (Refer to Fig. 1-4)

1. Remove the screw ①.
2. Remove the 2 screws ②.
3. Remove the 2 screws ③.
4. Remove the Syscon PCB in the direction of arrow.

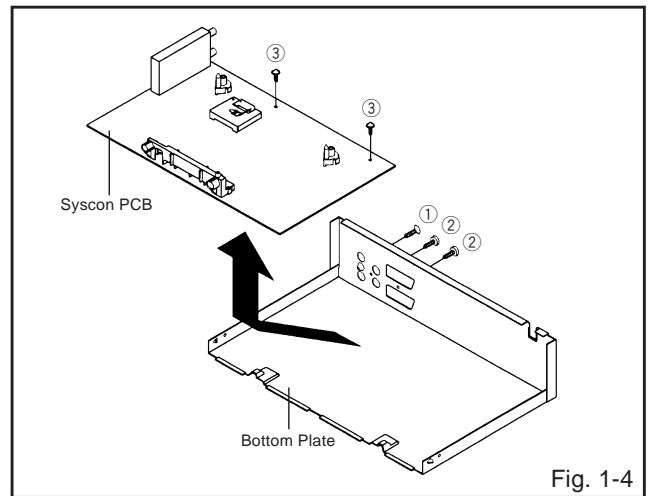

DISASSEMBLY INSTRUCTIONS

2. REMOVAL OF DECK PARTS

2-1: TOP BRACKET (Refer to Fig. 2-1)

1. Remove the 2 screws ①.
2. Slide the 2 supports ② and remove the Top Bracket.

NOTE

When you install the Top Bracket, install the screw (1) first, then install the screw (2).

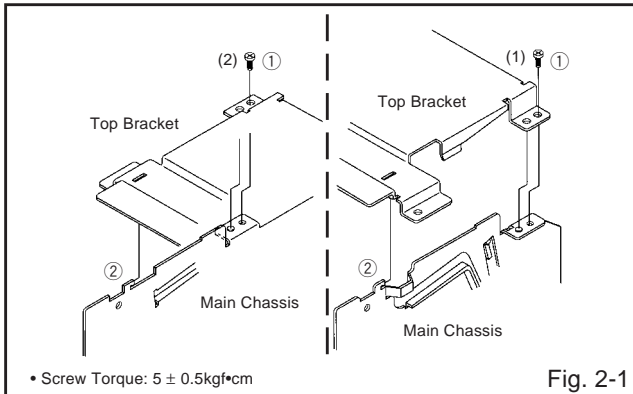

Fig. 2-1

2-2: DECK COVER/FLAP LEVER/TAPE GUIDE R (Refer to Fig. 2-2)

1. Move the Cassette Holder Ass'y to the back side.
2. Unlock the support ① and remove the Deck Cover.
3. Remove the Polyslider Washer ②.
4. Unlock the support ③ and remove the Flap Lever.
5. Unlock the 3 supports ④ and remove the Tape Guide R.

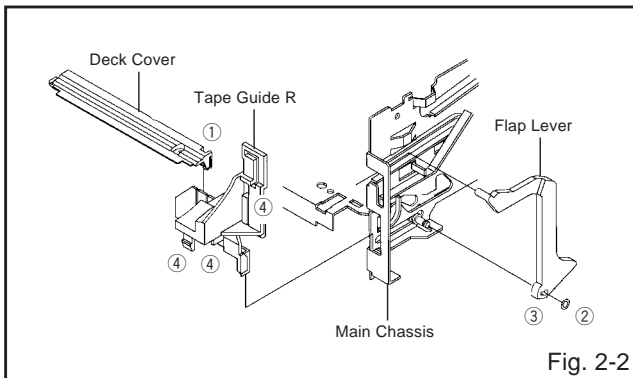

Fig. 2-2

2-3: TAPE GUIDE L (Refer to Fig. 2-3-A)

1. Move the Cassette Holder Ass'y to the back side.
2. Unlock the 2 supports ① and remove the Tape Guide L.
3. Remove the REC Lever. (Recorder only)

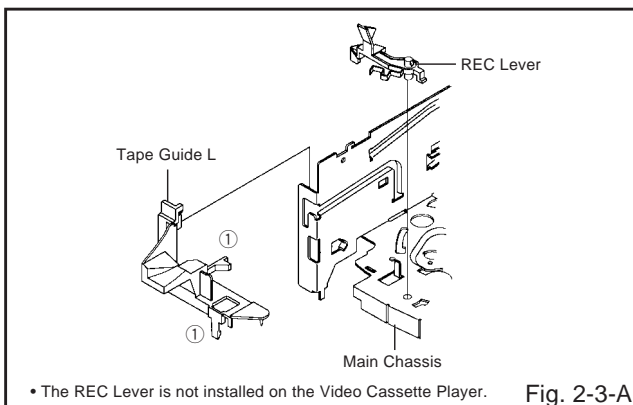

Fig. 2-3-A

NOTE

When you install the Tape Guide L, install as shown in the circle of Fig. 2-3-B. (Refer to Fig. 2-3-B)

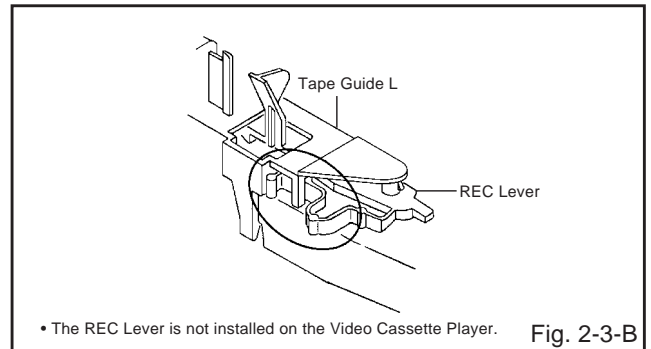

Fig. 2-3-B

2-4: CASSETTE HOLDER ASS'Y (Refer to Fig. 2-4)

1. Move the Cassette Holder Ass'y to the front side.
2. Push the Locker R to remove the Cassette Side R.
3. Remove the Cassette Side L.

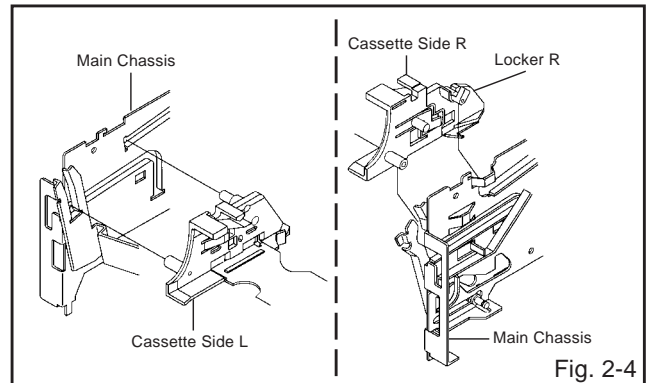

Fig. 2-4

2-5: CASSETTE SIDE L/R (Refer to Fig. 2-5)

1. Remove the Locker Spring.
2. Unlock the 4 supports ① and then remove the Cassette Side L/R.

NOTE

When you install the Cassette Side L/R, be sure to move the Locker L/R after installing.

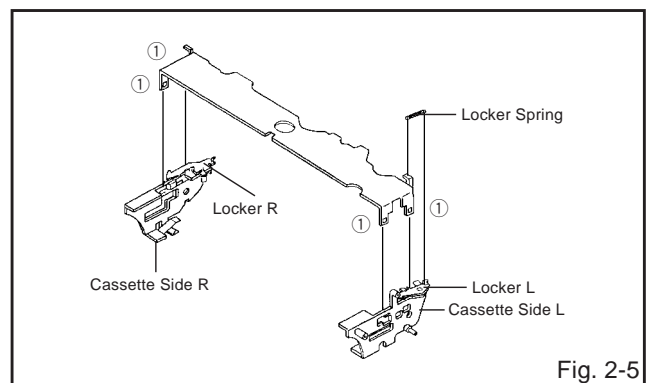

Fig. 2-5

DISASSEMBLY INSTRUCTIONS

2-6: LINK ASS'Y (Refer to Fig. 2-6)

1. Set the Link Ass'y to the Eject position.
2. Remove the (A) side of the Link Ass'y first, then remove the (B) side.

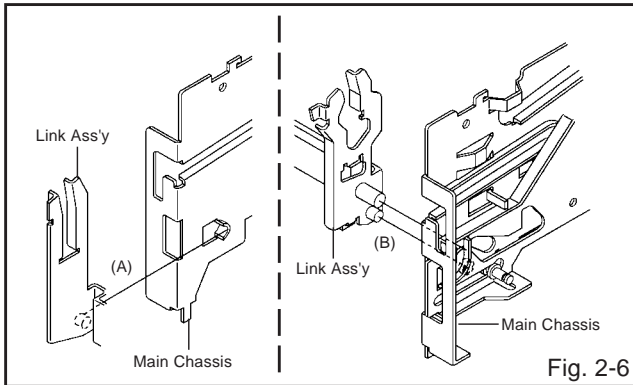

Fig. 2-6

2-7: LOADING MOTOR ASS'Y (Refer to Fig. 2-7)

1. Remove the Link Lever.
2. Remove the Dumper Spring.
3. Remove the 2 screws ①.
4. Unlock the support ② and remove the Loading Motor Ass'y.
5. Unlock the 2 supports ③ and remove the Deck PCB (BOT).

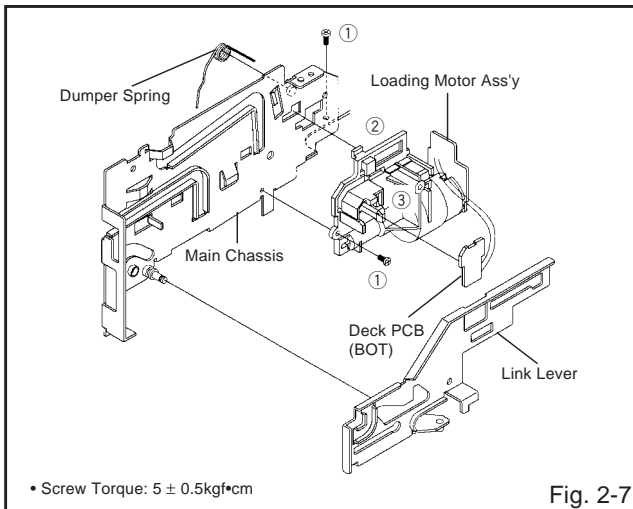

Fig. 2-7

2-8: SENSOR COVER L (Refer to Fig. 2-8)

1. Unlock the support ① and remove the Sensor Cover L.
2. Unlock the 2 supports ② and remove the Deck PCB (EOT).

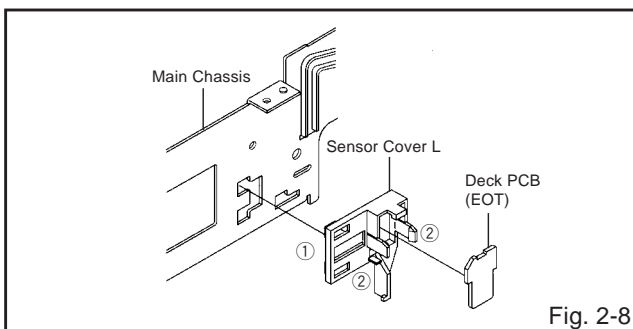

Fig. 2-8

2-9: TENSION ASS'Y (Refer to Fig. 2-9-A)

1. Move the Inclined S Ass'y to the back side.
2. Unlock the support ① and remove the S Reel Stopper.
3. Remove the Tension Spring.
4. Unlock the support ② and remove the Tension Arm Ass'y.
5. Remove the Tension Adjust.
6. Unlock the 2 supports ③ and remove the Tension Band Ass'y.
7. Unlock the support ④ and remove the Tension Holder.

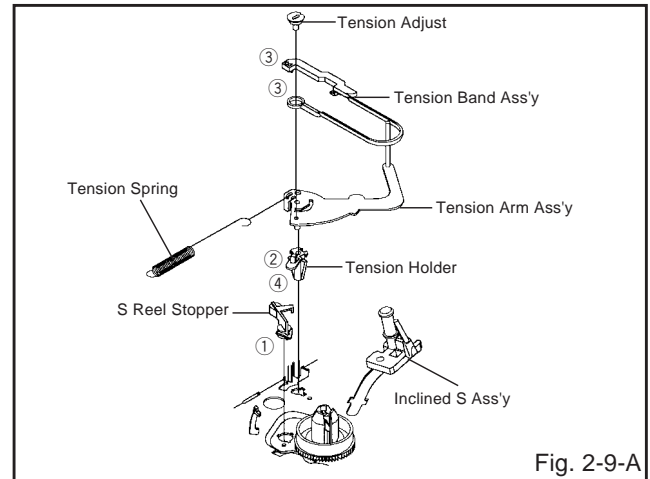

Fig. 2-9-A

NOTE

When you install the Tension Adjust, install as shown in Fig. 2-9-B. (Refer to Fig. 2-9-B)

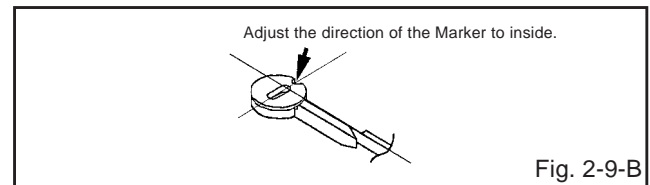

Fig. 2-9-B

2-10: T BRAKE ASS'Y (Refer to Fig. 2-10)

1. Remove the T Brake Spring.
2. Remove the T Brake Ass'y.

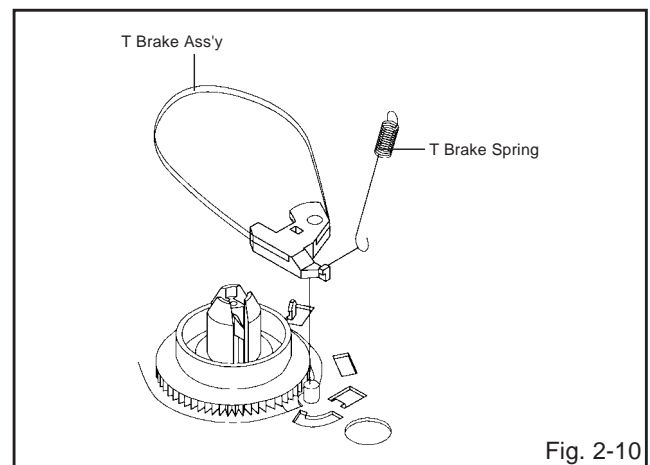

Fig. 2-10

DISASSEMBLY INSTRUCTIONS

2-11: S REEL/T REEL ASS'Y (Refer to Fig. 2-11)

1. Remove the Idler Ass'y.
2. Remove the S Reel and T Reel Ass'y.
3. Remove the 2 Polyslider Washers ①.

NOTE

1. Take care not to damage the gears of the S Reel, T Reel Ass'y and Idler Ass'y.
2. The Polyslider Washer may be remained on the back of the reel.
3. Take care not to damage the shaft.
4. Do not touch the section "A" of S Reel and T Reel Ass'y. (Use gloves.) **(Refer to Fig. 2-11)** Do not adhere the stains on it.
5. When you install the reel, clean the shaft and oil it (KYODO OIL Slidas #150). (If you do not oil, noise may be heard in FF/REW mode.)
6. After installing the reel, adjust the height of the reel. **(Refer to MECHANICAL ADJUSTMENT)**

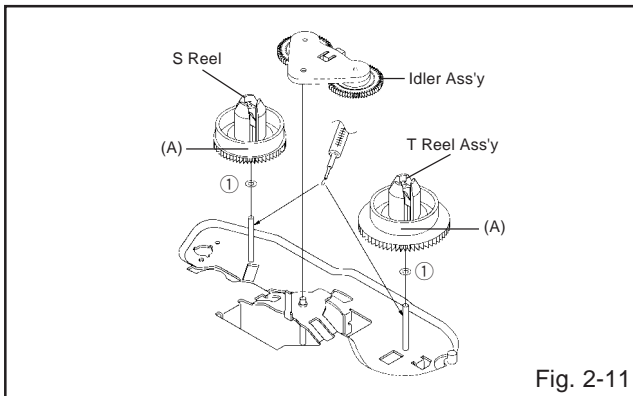

Fig. 2-11

2-12: PINCH ROLLER ASS'Y/P5 ARM ASS'Y (Refer to Fig. 2-12-A)

1. Remove the P5 Spring.
2. Remove the screw ①.
3. Unlock the 2 supports ② and remove the Cassette Opener.
4. Remove the Pinch Roller Ass'y, Pinch Roller Lever and P5 Arm Ass'y.

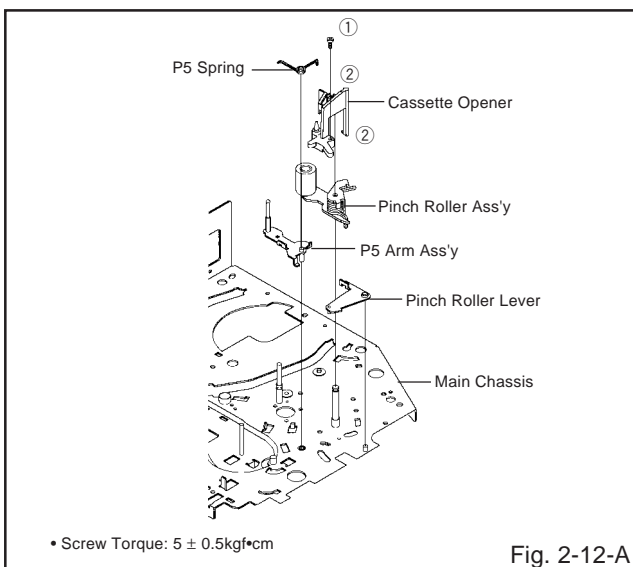

Fig. 2-12-A

NOTE

1. Do not touch the Pinch Roller. (Use gloves.)
2. When you install the Pinch Roller Ass'y, install as shown in the circle. **(Refer to Fig. 2-12-B)**

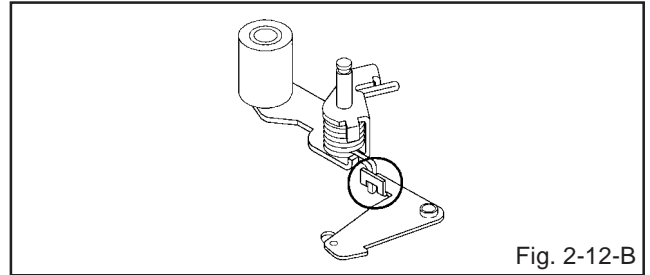

Fig. 2-12-B

2-13: A/C HEAD (Refer to Fig. 2-13-A)

1. Remove the screw ①.
2. Remove the A/C Head Base.
3. Remove the 3 screws ②.
4. Remove the A/C Head and A/C Head Spring.

NOTE

1. Do not touch the A/C Head. (Use gloves.)
2. When you install the A/C Head Spring, install as shown in Fig. 2-13-B. **(Refer to Fig. 2-13-B)**
3. When you install the A/C Head, tighten the screw (1) first, then tighten the screw (2), finally tighten the screw (3).

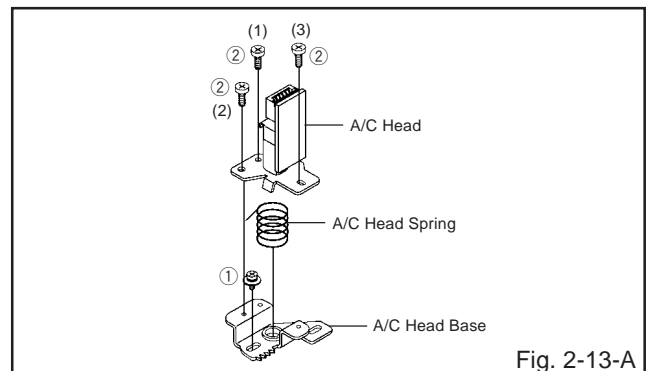

Fig. 2-13-A

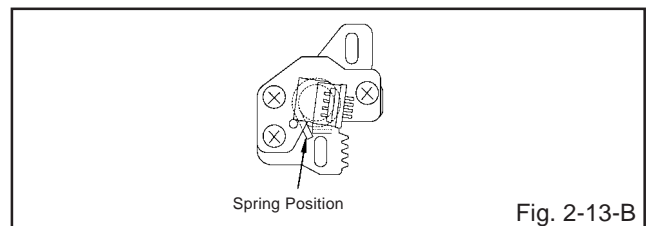

Fig. 2-13-B

2-14: FE HEAD (RECORDER ONLY) (Refer to Fig. 2-14)

1. Remove the screw ①.
2. Remove the FE Head.

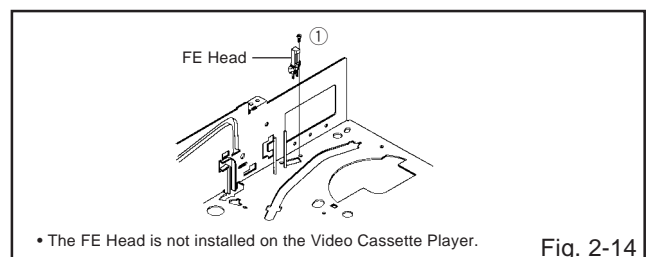

Fig. 2-14

DISASSEMBLY INSTRUCTIONS

2-15: AHC ASS'Y/CYLINDER UNIT ASS'Y (Refer to Fig. 2-15)

1. Unlock the support ① and remove the AHC Ass'y.
2. Remove the 3 screws ②.
3. Remove the Cylinder Unit Ass'y.

NOTE

When you install the Cylinder Unit Ass'y, tighten the screws from (1) to (3) in order while pulling the Ass'y toward the left front direction.

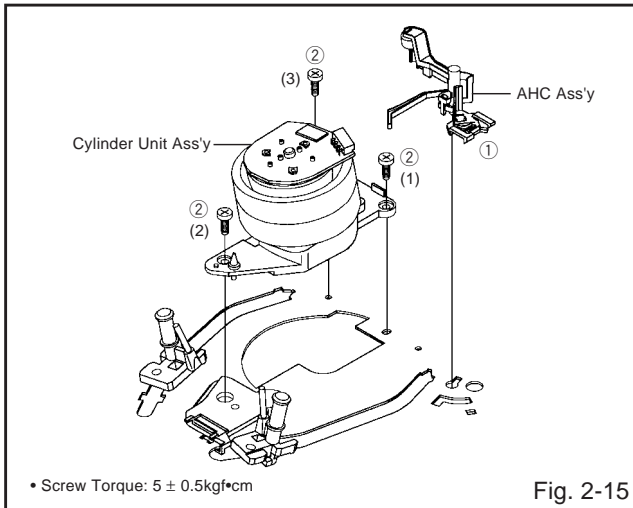

2-16: CAPSTAN DD UNIT (Refer to Fig. 2-16)

1. Remove the Capstan Belt.
2. Remove the 3 screws ①.
3. Remove the Capstan DD Unit.

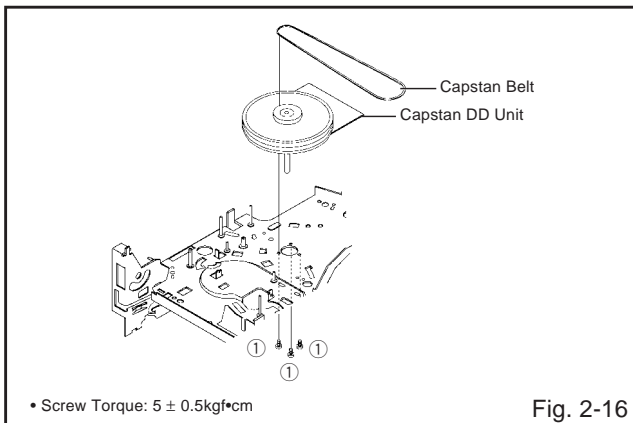

2-17: MIDDLE GEAR/MAIN CAM (Refer to Fig. 2-17-A)

1. Remove the Polyslider Washer ①, then remove the Middle Gear.
2. Remove the E-Ring, then remove the Main Cam, Link Lever Spacer and P5 Cam.
3. Remove the Polyslider Washer ②, then remove the Pinch Roller Cam.
4. Remove the Polyslider Washer ③, then remove the Joint Gear.

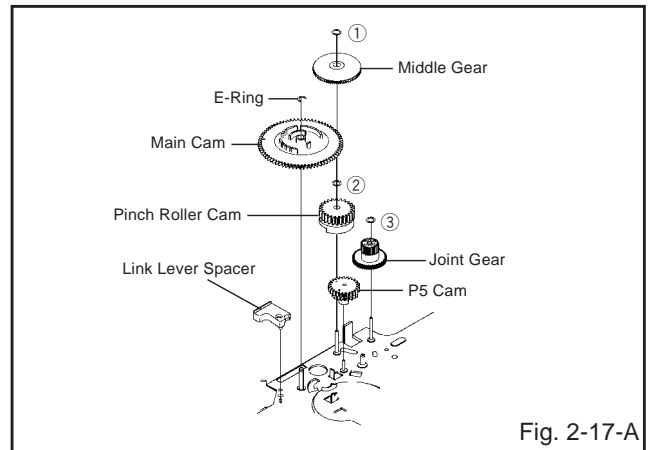

NOTE

When you install the Pinch Roller Cam, P5 Cam and Main Cam, align each marker. (Refer to Fig. 2-17-B)

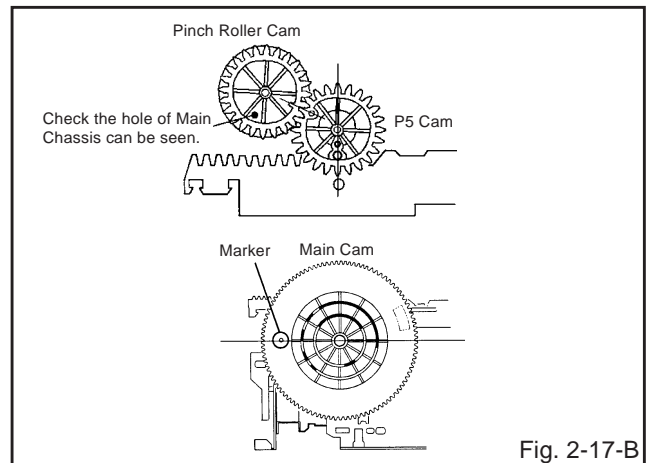

2-18: CLUTCH ASS'Y (Refer to Fig. 2-18)

1. Remove the Polyslider Washer ①.
2. Remove the Clutch Ass'y, Ring Spring, Ring Clutch, Gear Clutch and Polyslider Washer ②.

NOTE

When you install the Clutch Ass'y, oil the shaft (KYODO OIL Slidas #150).

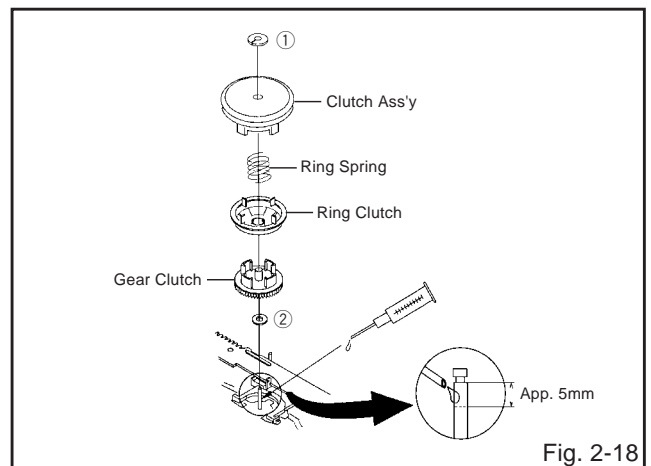

DISASSEMBLY INSTRUCTIONS

2-19: LOADING GEAR S/T ASS'Y (Refer to Fig. 2-19-A)

1. Remove the E-Ring ① and remove the Main Loading Gear.
2. Remove the Capstan Brake Spring.
3. Slide the Main Rod and remove the Capstan Brake Arm Ass'y.
4. Remove the Main Rod.
5. Remove the Tension Lever.
6. Unlock the 2 supports ② and remove the Clutch Lever.
7. Remove the screw ③ and washer ④.
8. Remove the LED Reflector.
9. Remove the Loading Arm S Ass'y and Loading Arm T Ass'y.
10. Remove the Loading Gear S and Loading Gear T.
11. Remove the Loading Gear Spring.

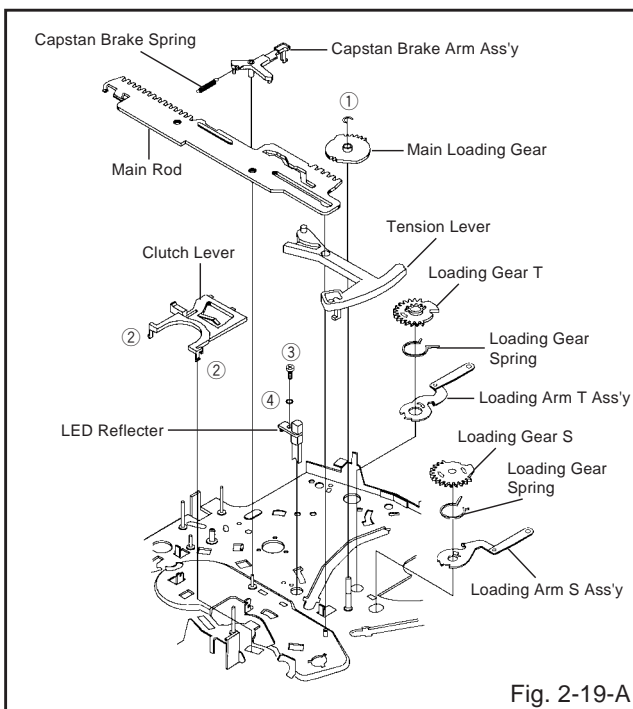

NOTE

When you install the Loading Arm S Ass'y, Loading Arm T Ass'y and Main Loading Gear, align each marker. (Refer to Fig. 2-19-B)

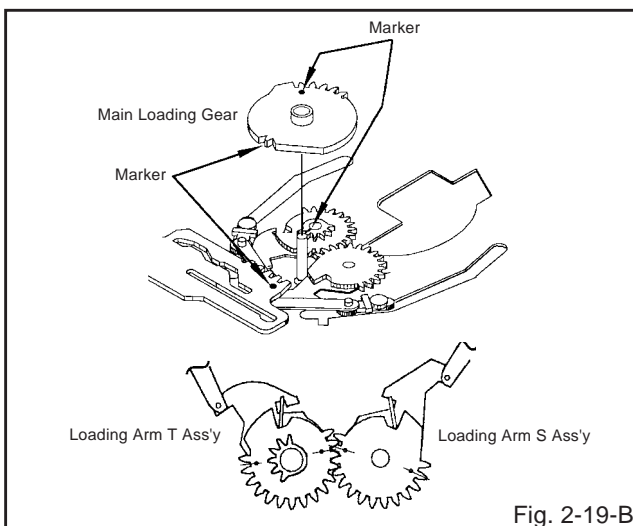

2-20: INCLINED S/T ASS'Y (Refer to Fig. 2-20)

1. Unlock the support ① and remove the P4 Cover.
2. Remove the S-S Brake Spring.
3. Unlock the support ② and remove the Loading Gear Holder.
4. Remove the S-S Brake Arm.
5. Remove the Inclined S.
6. Remove the Inclined T.
7. Remove the 2 screws ③, then remove the Guide Roller and O-Ring.

NOTE

Do not touch the roller of Guide Roller.

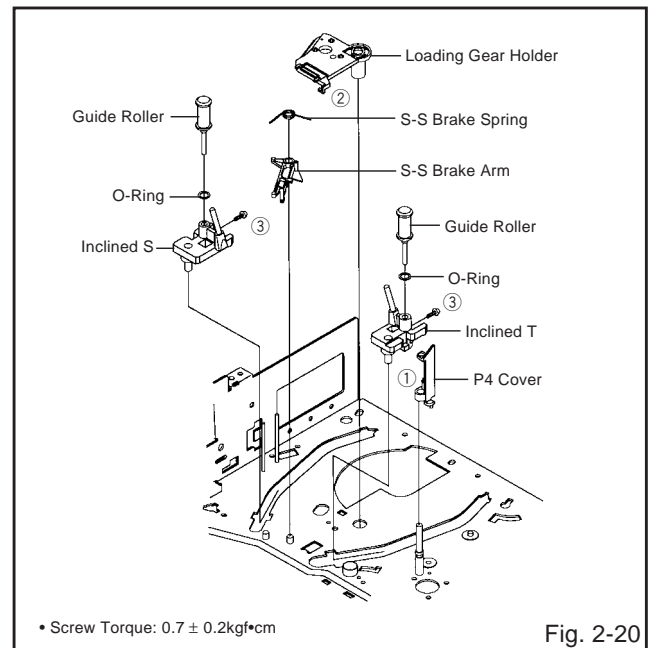

KEY TO ABBREVIATIONS

A	A/C	: Audio/Control	H.SW	: Head Switch	
	ACC	: Automatic Color Control	Hz	: Hertz	
	AE	: Audio Erase	I	IC	: Integrated Circuit
	AFC	: Automatic Frequency Control		IF	: Intermediate Frequency
	AFT	: Automatic Fine Tuning		IND	: Indicator
	AFT DET	: Automatic Fine Tuning Detect		INV	: Inverter
	AGC	: Automatic Gain Control	K	KIL	: Killer
	AMP	: Amplifier	L	L	: Left
	ANT	: Antenna		LED	: Light Emitting Diode
	A.PB	: Audio Playback		LIMIT AMP	: Limiter Amplifier
	APC	: Automatic Phase Control		LM, LDM	: Loading Motor
	ASS'Y	: Assembly		LP	: Long Play
	AT	: All Time		L.P.F	: Low Pass Filter
	AUTO	: Automatic		LUMI.	: Luminance
	A/V	: Audio/Video	M	M	: Motor
B	BGP	: Burst Gate Pulse		MAX	: Maximum
	BOT	: Beginning of Tape		MINI	: Minimum
	BPF	: Bandpass Filter		MIX	: Mixer, mixing
	BRAKE SOL	: Brake Solenoid		MM	: Monostable Multivibrator
	BUFF	: Buffer		MOD	: Modulator, Modulation
	B/W	: Black and White		MPX	: Multiplexer, Multiplex
C	C	: Capacitance, Collector		MS SW	: Mecha State Switch
	CASE	: Cassette	N	NC	: Non Connection
	CAP	: Capstan		NR	: Noise Reduction
	CARR	: Carrier	O	OSC	: Oscillator
	CH	: Channel		OPE	: Operation
	CLK	: Clock	P	PB	: Playback
	CLOCK (SY-SE)	: Clock (Syscon to Servo)		PB CTL	: Playback Control
	COMB	: Combination, Comb Filter		PB-C	: Playback-Chrominance
	CONV	: Converter		PB-Y	: Playback-Luminance
	CPM	: Capstan Motor		PCB	: Printed Circuit Board
	CTL	: Control		P. CON	: Power Control
	CYL	: Cylinder		PD	: Phase Detector
	CYL-M	: Cylinder-Motor		PG	: Pulse Generator
	CYL SENS	: Cylinder-Sensor		P-P	: Peak-to Peak
D	DATA (SY-CE)	: Data (Syscon to Servo)	R	R	: Right
	dB	: Decibel		REC	: Recording
	DC	: Direct Current		REC-C	: Recording-Chrominance
	DD Unit	: Direct Drive Motor Unit		REC-Y	: Recording-Luminance
	DEMODO	: Demodulator		REEL BRK	: Reel Brake
	DET	: Detector		REEL S	: Reel Sensor
	DEV	: Deviation		REF	: Reference
E	E	: Emitter		REG	: Regulated, Regulator
	EF	: Emitter Follower		REW	: Rewind
	EMPH	: Emphasis		REV, RVS	: Reverse
	ENC	: Encoder		RF	: Radio Frequency
	ENV	: Envelope		RMC	: Remote Control
	EOT	: End of Tape		RY	: Relay
	EQ	: Equalizer	S	S. CLK	: Serial Clock
	EXT	: External		S. COM	: Sensor Common
F	F	: Fuse		S. DATA	: Serial Data
	FBC	: Feed Back Clamp		SEG	: Segment
	FE	: Full Erase		SEL	: Select, Selector
	FF	: Fast Forward, Flipflop		SENS	: Sensor
	FG	: Frequency Generator		SER	: Search Mode
	FL SW	: Front Loading Switch		SI	: Serial Input
	FM	: Frequency Modulation		SIF	: Sound Intermediate Frequency
	FSC	: Frequency Sub Carrier		SO	: Serial Output
	FWD	: Forward		SOL	: Solenoid
G	GEN	: Generator		SP	: Standard Play
	GND	: Ground		STB	: Serial Strobe
H	H.P.F	: High Pass Filter		SW	: Switch

KEY TO ABBREVIATIONS

S	SYNC	:	Synchronization
	SYNC SEP	:	Sync Separator, Separation
T	TR	:	Transistor
	TRAC	:	Tracking
	TRICK PB	:	Trick Playback
	TP	:	Test Point
U	UNREG	:	Unregulated
V	V	:	Volt
	VCO	:	Voltage Controlled Oscillator
	VIF	:	Video Intermediate Frequency
	VP	:	Vertical Pulse, Voltage Display
	V.PB	:	Video Playback
	VR	:	Variable Resistor
	V.REC	:	Video Recording
	VSF	:	Visual Search Fast Forward
	VSR	:	Visual Search Rewind
	VSS	:	Voltage Super Source
	V-SYNC	:	Vertical-Synchronization
	VT	:	Voltage Tuning
X	X'TAL	:	Crystal
Y	Y/C	:	Luminance/Chrominance

SERVICE MODE LIST

This unit provided with the following SERVICE MODES so you can repair, examine and adjust easily.

Method	Operations
Press both PLAY button and CH UP button on the set for more than 2 seconds.	Initialization of the factory. NOTE: Do not use this for the normal servicing.
Press both FF button and CH UP button on the set for more than 2 seconds.	PLAY/REC total hours are displayed on the FIP. Refer to the "PREVENTIVE CHECKS AND SERVICE INTERVALS" (CONFIRMATION OF USING HOURS). Can be checked of the INITIAL DATA of MEMORY IC. Refer to the "NOTE FOR THE REPLACING OF MEMORY IC".
Press the ATR button on the remote control for more than 2 seconds during PLAY.	Adjusting of the Tracking to the center position. Refer to the "MECHANICAL ADJUSTMENT" (GUIDE ROLLER) and "ELECTRICAL ADJUSTMENT" (PG SHIFTER).
Press both STOP button and CH UP button on the set for more than 2 seconds during PLAY.	Adjust the PG SHIFTER automatically. Refer to the "ELECTRICAL ADJUSTMENT" (PG SHIFTER).
Press both CH UP button and CH DOWN button on the set for more than 2 seconds.	CH Preset and Clock Setting are automatically set. (AUTO SET UP)
Make the short circuit between the test point of SERVICE and the GND.	The EOT/BOT/Reel sensor do not work at this moment. Refer to the "PREPARATION FOR SERVICING"

PREVENTIVE CHECKS AND SERVICE INTERVALS

The following standard table depends on environmental conditions and usage. Unless maintenance is properly carried out, the following service intervals may be quite shortened as harmful effects may be had on other parts. Also, long term storage or misuse may cause transformation and aging of rubber parts.

Time Parts Name	500 hours	1,000 hours	1,500 hours	2,000 hours	3,000 hours	Notes
Audio Control Head	■	■	■	■	■	Clean those parts in contact with the tape.
Full Erase Head (Recorder only)	■	■	■	■	■	
Capstan Belt			■	■	●	Clean the rubber, and parts which the rubber touches.
Pinch Roller	■	■	■	■	■ ●	
Capstan DD Unit					●	
Loading Motor					●	
Tension Band					●	
Capstan Shaft	■	■	■	■	■	
Tape Running Guide Post	■	■	■	■	■	Replace when rolling becomes abnormal.
Cylinder Unit	■	■	■	■	●	Clean the Head

- : Clean
- : Replace

CONFIRMATION OF USING HOURS

PLAY/REC total hours can be checked on the FIP.
Total hours are displayed in 16 system of notation.

1. Press both FF button and CH UP button on the set for more than 2 seconds.
2. Adjust the ADDRESS to "FD" by SET +/- button and read the DATA.
(This DATA becomes the thousands digit and hundreds digit value of the following formula.)
3. Adjust the ADDRESS to "FE" by SET +/- button and read the DATA.
(This DATA becomes the tens digit and ones digit value of the following formula.)
4. After the confirmation of using hours, turn off the power.

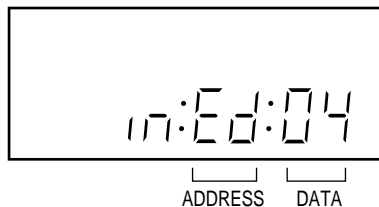

$(16 \times 16 \times 16 \times \text{thousands digit value}) + (16 \times 16 \times \text{hundreds digit value}) + (16 \times \text{tens digit value}) + (\text{ones digit value})$

PREVENTIVE CHECKS AND SERVICE INTERVALS

CLEANING

NOTE

After cleaning the heads with isopropyl alcohol, do not run a tape until the heads dry completely. If the heads are not completely dry and alcohol gets on the tape, damage may occur.

1. AUDIO CONTROL HEAD

Wrap a piece of chamois around your finger. Dip it in isopropyl alcohol and clean the audio control head by wiping it horizontally. Clean the full erase head in the same manner. **(Refer to the figure below.)**

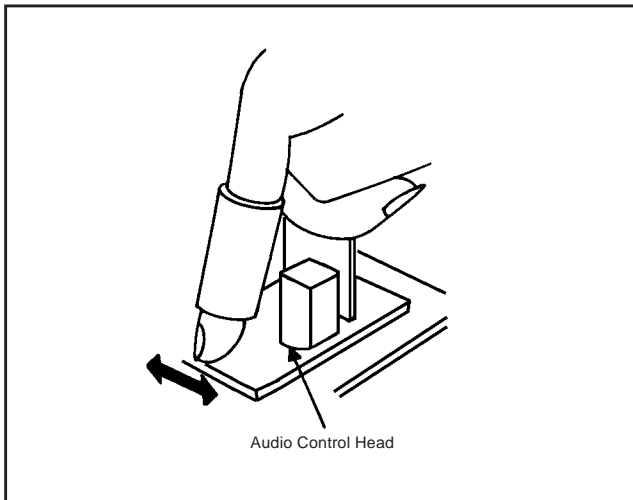

2. TAPE RUNNING SYSTEM

When cleaning the tape transport system, use the gauze moistened with isopropyl alcohol.

3. CYLINDER

Wrap a piece of chamois around your finger. Dip it in isopropyl alcohol. Hold it to the cylinder head softly. Turn the cylinder head counterclockwise to clean it (in the direction of the arrow). **(Refer to the figure below.)**

NOTE

Do not exert force against the cylinder head. Do not move the chamois upward or downward on the head. Use the chamois one by one.

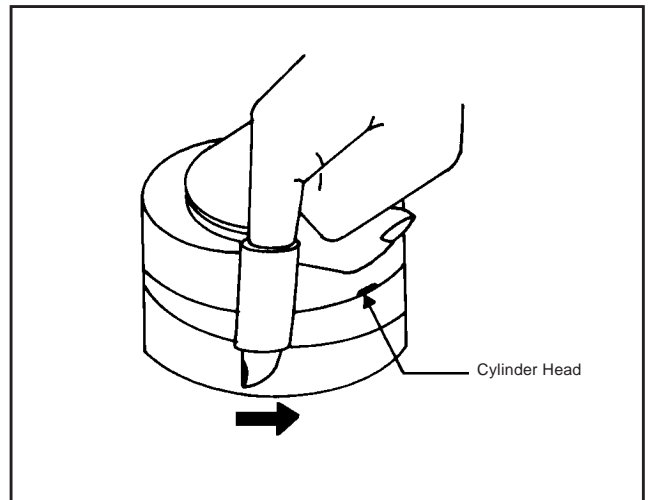

NOTE FOR THE REPLACING OF MEMORY IC

If a service repair is undertaken where it has been required to change the MEMORY IC, the following steps should be taken to ensure correct data settings while making reference to TABLE 1.

ADDRESS	DATA	ADDRESS	DATA	ADDRESS	DATA	ADDRESS	DATA	ADDRESS	DATA
CC	F1	D6	80	E0	76	EA	51	F4	41
CD	44	D7	00	E1	5E	EB	5F	F5	83
CE	24	D8	71	E2	08	EC	09	F6	3D
CF	88	D9	9F	E3	F0	ED	F0	F7	6B
D0	92	DA	02	E4	01	EE	05	F8	0B
D1	45	DB	0A	E5	F3	EF	F3	F9	0C
D2	00	DC	42	E6	6C	F0	00	FA	04
D3	02	DD	35	E7	2B	F1	2F	FB	3A
D4	09	DE	A3	E8	21	F2	DF	FC	99
D5	03	DF	56	E9	15	F3	41		

Table 1

1. Turn on the POWER and press both FF key and CH UP key on the set for more than 2 seconds.
2. ADDRESS and DATA should appear as FIG 1.

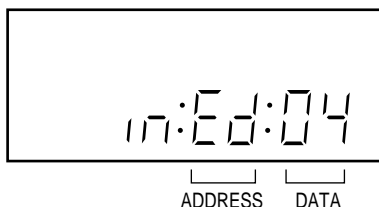
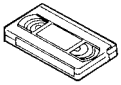
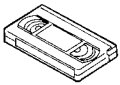
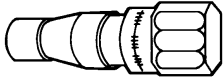
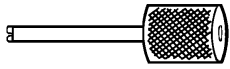
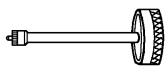
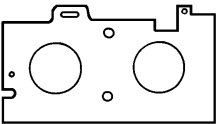
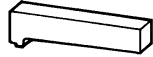
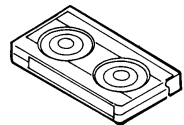
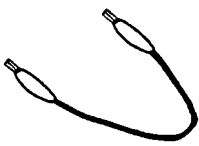
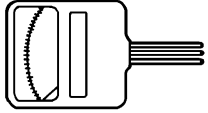

Fig. 1

3. ADDRESS is now selected and should "blink". Using the SET + or - keys on the remote, step through the ADDRESS until required ADDRESS to be changed is reached.
4. Press ENTER to select DATA. When DATA is selected, it will "blink".
5. Again, step through the DATA using SET + or - until required DATA value has been selected.
6. Pressing ENTER will take you back to ADDRESS for further selection if necessary.
7. Repeat steps 3 to 6 until all data has been checked.
8. When satisfied correct DATA has been entered, turn POWER off (return to STANDBY MODE) to finish DATA input. The unit will now have the correct DATA for the new MEMORY IC.

SERVICING FIXTURES AND TOOLS

<p>(For 1 speed model) VHS Alignment Tape JG001E (TTV-P2) JG001F (TTV-P1L) JG001U (VP₁S-X6³)</p> 	<p>(For 2 speed model) VHS Alignment Tape JG001C (TTV-P2) JG001D (TTV-P1L) JG001V (VP₂S-X6³)</p> 	<p>JG002B Adapter JG002E Dial Torque Gauge (10~90gf•cm) JG002F (60~600gf•cm)</p> 	<p>JG005 Post Adjustment Screwdriver Part No. SV-TG0-030-000 (small)</p> 
<p>JG153 X Value Adjustment Screwdriver</p> 	<p>JG022 Master Plane</p> 	<p>JG024A Reel Disk Height Adjustment Jig</p> 	<p>JG100A Torque Tape (VHT-063)</p> 
<p>JG154 Cable Parts No. SJ-G15-400-000</p> 	<p>Tentelometer</p> 		

Part No.	Remarks
JG001E	Stair Steps, 6KHz (For 1 speed model)
JG001F	Color Bar, 1KHz (For 1 speed model)
JG001U	X Value Adjustment (For 1 speed model)
JG001C	Stair Steps, 7KHz (For 2 speed model)
JG001D	Color Bar, 1KHz (For 2 speed model)
JG001V	X Value Adjustment (For 2 speed model)
JG002B	VSR Torque, Brake Torque (S Reel/T Reel Ass'y)
JG002E	Brake Torque (T Reel Ass'y)
JG002F	VSR Torque, Brake Torque (S Reel)
JG005	Guide Roller Adjustment
JG153	X Value Adjustment
JG022/JG024A	Reel Disk Height Adjustment
JG100A	Playback Torque, Back Tension Torque During Playback
JG154	Used to connect the test point of SERVICE and GROUND

PREPARATION FOR SERVICING

How to use the Servicing Fixture

1. Short circuit between **TP1001** and **TP1002** with the cable JG154.

(Refer to ELECTRICAL ADJUSTMENT PARTS LOCATION GUIDE)

The EOT, BOT and Reel Sensor do not work at this moment.

At that time, the STOP/EJECT button is available to insert and eject the Cassette Tape.

VCR TEST TAPE INTERCHANGEABILITY TABLE

There are two types of the new alignment tape CH-1B (for NTSC) and CH-2 (for PAL). On each tape four signals (1) - (4) are recorded for the times and in the order shown below.

(1) : 8min. ---> (2) : 2min. ---> (3) : 5min. ---> (4) : 5min.

The TTV-MP1 (for M-PAL), TTV-MS1 (for MESECAM) and TTV-S1 (for SECAM) alignment tapes have the same contents as the previous tapes.

Method	Now in use TYPE		New TYPE		Application
	Model	Contents*1	Model	Contents*1	
NTSC	TTV-N1	NTSC, Color, 1kHz, SP	CH-1B(2)	NTSC, Stairsteps, 1kHz, SP	PB-Y Level/General electrical ADJ. Head ACE Height/Tilt ADJ.
	TTV-N1E	NTSC, Color, 1kHz, EP	CH-1B(4) *2	NTSC, Color, 1kHz, EP	Switching position ADJ.
	TTV-N2	NTSC, Stairsteps, 7kHz, SP	CH-1B(1)	NTSC, Stairsteps, 7kHz, SP	Head ACE Azimuth ADJ.
	TTV-N12 (SCV-1998)	NTSC, Color, 1kHz, SP	CH-1B(4)	NTSC, Color, 1kHz, EP	FM envelope ADJ. X-Value ADJ.
	TTV-N7A	NTSC, Stairsteps, 1kHz, SP, HiFi 400Hz	CH-1B(3)	NTSC, Color, No sound SP, HiFi 400Hz	HiFi Audio PB Level ADJ.
PAL	TTV-P1	PAL, Color, 1kHz, SP	CH-2(2) *3	PAL, Stairsteps, 1kHz, SP	Switching position ADJ. PB-Y Level/General electrical ADJ. Head ACE Height/Tilt ADJ.
	TTV-P1L	PAL, Color, 1kHz, LP	CH-2(4)	PAL, Color, 1kHz, LP	Switching position. (LP Model) FM Envelope ADJ. (LP Model) X-Value ADJ. (LP Model)
	TTV-P2	PAL, Stairsteps, 6kHz, SP	CH-2(1)	PAL, Stairsteps, 6kHz, SP	Head ACE Azimuth ADJ. FM Envelope ADJ. (SP Model) X-Value ADJ. (SP Model)
	TTV-P7	PAL, Stairsteps, 1kHz, SP, HiFi, 1kHz	CH-2(3)	PAL, Color, No sound SP, HiFi 400Hz	HiFi Audio PB Level ADJ.
	TTV-P16	PAL, Color, 400Hz, SP, HiFi 1kHz	No Changed.		FM Filter ADJ.

*1. Described in the order of color format. Video signal. Linear audio. Tape speed and Hi-Fi audio.

*2. Use CH-1B (1) - (3) with models used exclusively in the SP mode.

*3. Use CH-2 (3) and (4) when it is necessary to observe the chroma signal.

MECHANICAL ADJUSTMENTS

1. CONFIRMATION AND ADJUSTMENT

Read the following NOTES before starting work.

- Place an object which weighs between 450g~500g on the Cassette Tape to keep it steady when you want to make the tape run without the Cassette Holder. (Do not place an object which weighs over 500g.)
- When you activate the deck without the Cassette Holder, short circuit between **TP1001** and **TP1002**. (Refer to **ELECTRICAL ADJUSTMENT PARTS LOCATION GUIDE**) In this condition the BOT/EOT/Reel Sensor will not function.

1-1: CONFIRMATION AND ADJUSTMENT OF REEL DISK HEIGHT

1. Turn on the power and set to the STOP mode.
2. Set the master plane (**JG022**) and reel disk height adjustment jig (**JG024A**) on the mechanism framework, taking care not to scratch the drum, as shown in **Fig. 1-1-A**.
3. Confirm that "A" of the reel disk is lower than "B" of the reel disk height adjustment jig (**JG024A**), and is higher than "C". If it is not enough height, adjust to $10(+0.2, -0)$ mm with the height adjustment washer.
4. Adjust the other reel in the same way.

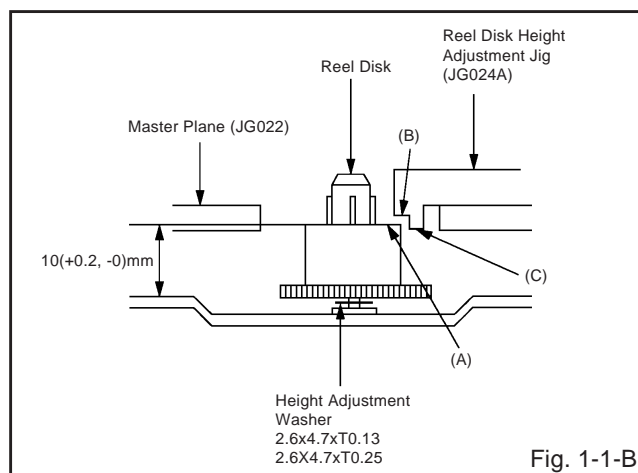
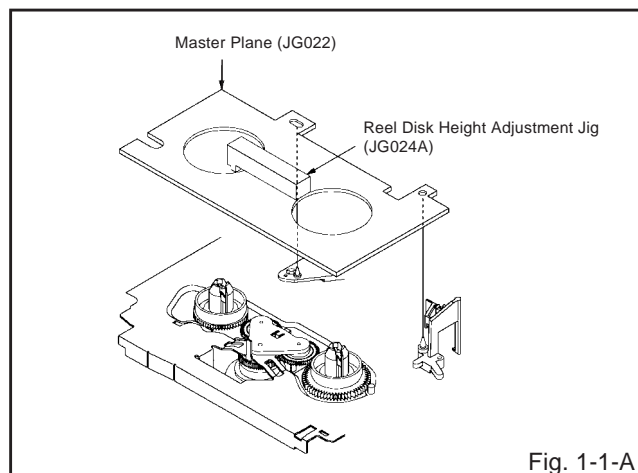

1-2: CONFIRMATION AND ADJUSTMENT OF TENSION POST POSITION

1. Set to the PLAY mode.
2. Adjust the Tension Adjust until the length from the edge of the Tension Arm to the standard line of the Main Chassis is 0.5 ± 0.25 mm. After this adjustment, confirm that the cut position is located in "A" area as shown in **Fig. 1-2-B**. If it is located in "B" area, adjust again.
3. While turning the S Reel clockwise, confirm that the edge of the Tension Arm is located in the position described above.

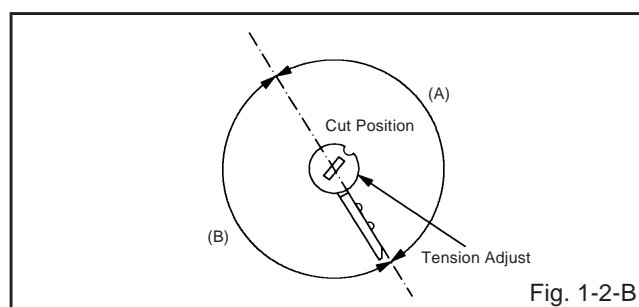
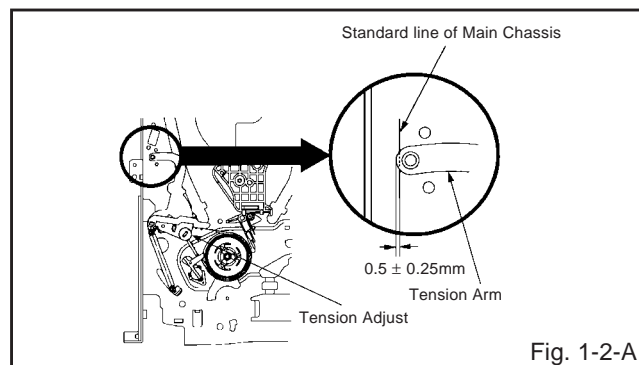

1-3: CONFIRMATION OF PLAYBACK TORQUE AND BACK TENSION TORQUE DURING PLAYBACK

1. Load a video tape (E-180) recorded in standard speed mode. Set the unit to the PLAY mode.
2. Install the tentelometer as shown in **Fig. 1-3**. Confirm that the meter indicates 20 ± 2 gf in the beginning of playback.

• USING A CASSETTE TYPE TORQUE TAPE (**JG100A**)

1. After confirmation and adjustment of Tension Post position (Refer to item 1-2), load the cassette type torque tape (**JG100A**) and set to the PLAY mode.
2. Confirm that the right meter of the torque tape indicates 70~130gf•cm during playback in SP mode.
3. Confirm that the left meter of the torque tape indicates 25~40gf•cm during playback in SP mode.

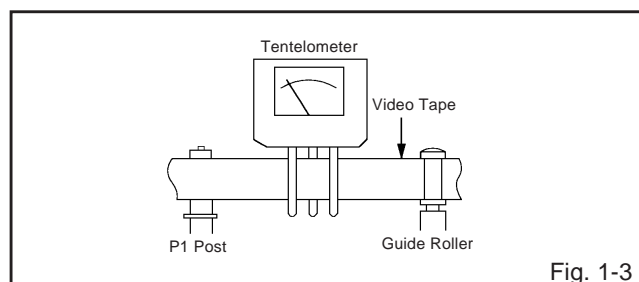

MECHANICAL ADJUSTMENTS

1-4: CONFIRMATION OF VSR TORQUE

1. Operate within 4~5 seconds after the reel disk begins to turn.
2. Install the Torque Gauge (JG002F) and Adapter (JG002B) on the S Reel. Set to the Rewind mode. (Refer to Fig.1-4)
3. Then, confirm that it indicates 120~180gf•cm.

NOTE

Install the Torque Gauge on the reel disk firmly. Press the REW button to turn the reel disk.

1-5: CONFIRMATION OF REEL BRAKE TORQUE

(S Reel Brake) (Refer to Fig. 1-4)

1. Set to the STOP mode.
2. Move the Idler Ass'y from the S Reel.
3. Install the Torque Gauge (JG002F) and Adapter (JG002B) on the S Reel. Turn the Torque Gauge (JG002F) clockwise.
4. Then, confirm that it indicates 70~100gf•cm.

(T Reel Brake) (Refer to Fig. 1-4)

1. Set to the STOP mode.
2. Move the Idler Ass'y from the T Reel Ass'y.
3. Install the Torque Gauge (JG002E) and Adapter (JG002B) on the T reel. Turn the Torque Gauge (JG002E) counterclockwise.
4. Then, confirm that it indicates 35~60gf•cm.

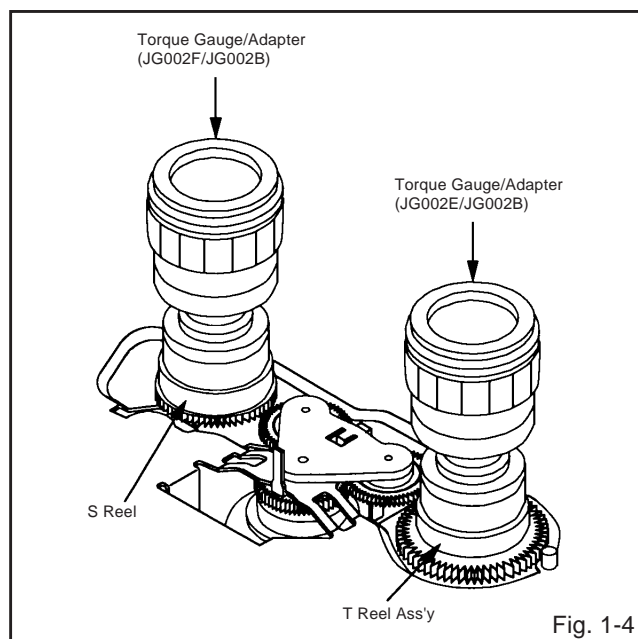

NOTE

If the torque is out of the range, replace the following parts.

Check item	Replacement Part
1-4	Idler Ass'y/Clutch Ass'y
1-5	T Brake Spring/Tension Spring

2. CONFIRMATION AND ADJUSTMENT OF TAPE RUNNING MECHANISM

Tape Running Mechanism is adjusted precisely at the factory. Adjustment is not necessary as usual. When you replace the parts of the tape running mechanism because of long term usage or failure, the confirmation and adjustment are necessary.

2-1: GUIDE ROLLER

1. Playback the VHS Alignment Tape (JG001C or JG001E). (Refer to SERVICING FIXTURE AND TOOLS)
2. Connect CH-1 of the oscilloscope to TP4002 (Envelope) and CH-2 to TP4001 (SW Pulse).
3. Press and hold the TRACKING-AUTO button on the remote control more than 2 seconds to set tracking to center.
4. Trigger with SW Pulse and observe the envelope. (Refer to Fig. 2-1-A)
5. When observing the envelope, adjust the Adjusting Driver (JG005) slightly until the envelope will be flat. Even if you press the Tracking Button, adjust so that flatness is not moved so much.
6. Adjust so that the A : B ratio is better than 3 : 2 as shown in Fig. 2-1-B, even if you press the Tracking Button to move the envelope (The envelope waveform will begin to decrease when you press the Tracking Button).
7. Adjust the PG shifter during playback. (Refer to the ELECTRICAL ADJUSTMENTS)

NOTE

After adjustment, confirm and adjust A/C head. (Refer to item 2-2)

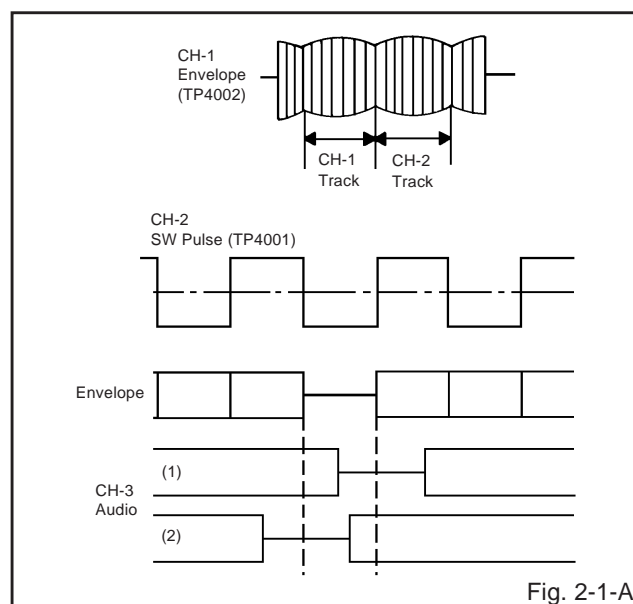

Fig. 2-1-A

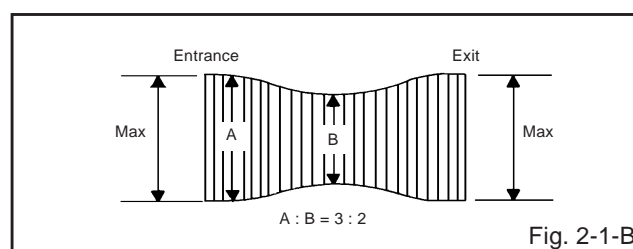

Fig. 2-1-B

MECHANICAL ADJUSTMENTS

2-2: CONFIRMATION AND ADJUSTMENT OF AUDIO/ CONTROL HEAD

When the Tape Running Mechanism does not work well, adjust the following items.

1. Playback the VHS Alignment Tape (JG001C or JG001E). (Refer to **SERVICING FIXTURE AND TOOLS**)
2. Confirm that the reflected picture of stamp mark is appeared on the tape prior to P4 Post as shown in **Fig. 2-2-A**.
 - a) When the reflected picture is distorted, turn the screw ① clockwise until the distortion is disappeared.
 - b) When the reflected picture is not distorted, turn the screw ① counterclockwise until little distortion is appeared, then adjust the a).
3. Turn the screw ② to set the audio level to maximum.
4. Confirm that the bottom of the Audio/ Control Head and the bottom of the tape is shown in **Fig. 2-2-C**.
 - c) When the height is not correct, turn the screw ③ to adjust the height. Then, adjust the 1~3 again.

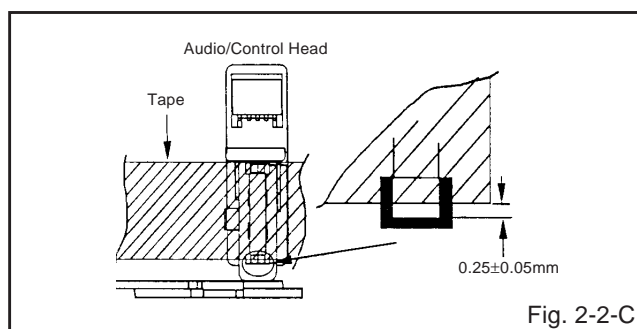
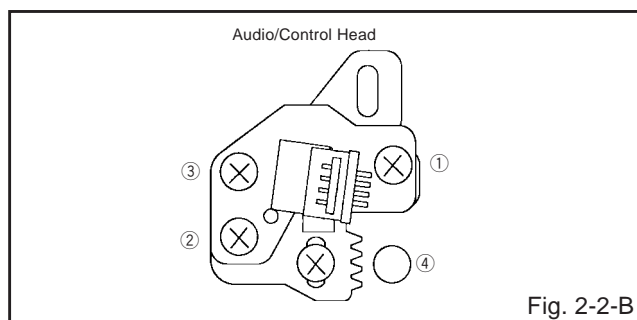
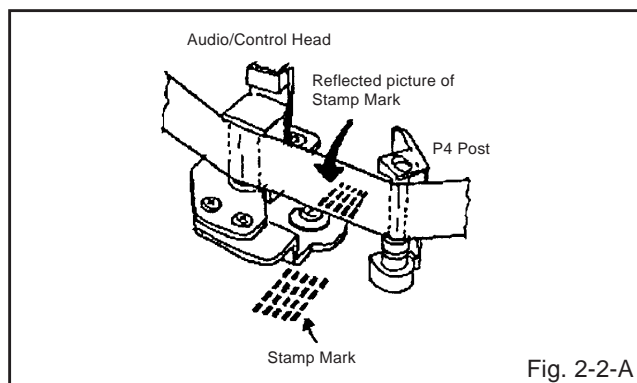

2-3: TAPE RUNNING ADJUSTMENT (X VALUE ADJUSTMENT)

1. Confirm and adjust the height of the Reel Disk. (Refer to **item 1-1**)
2. Confirm and adjust the position of the Tension Post. (Refer to **item 1-2**)
3. Adjust the Guide Roller. (Refer to **item 2-1**)
4. Confirm and adjust the Audio/Control Head. (Refer to **item 2-2**)
5. Connect CH-1 of the oscilloscope to **TP4001**, CH-2 to **TP4002** and CH-3 to **HOT side of Audio Out Jack**.
6. Playback the VHS Alignment Tape (JG001U or JG001V). (Refer to **SERVICING FIXTURE AND TOOLS**)
7. Press and hold the TRACKING-AUTO button on the remote control more than 2 seconds to set tracking to center.
8. Set the X Value adjustment driver (JG153) to the ④ of **Fig. 2-2-B**. Adjust X value so that the envelope waveform output becomes maximum. Check if the relation between Audio and Envelope waveform becomes (1) or (2) of **Fig. 2-1-A**.

MECHANICAL ADJUSTMENTS

3. MECHANISM ADJUSTMENT PARTS LOCATION GUIDE

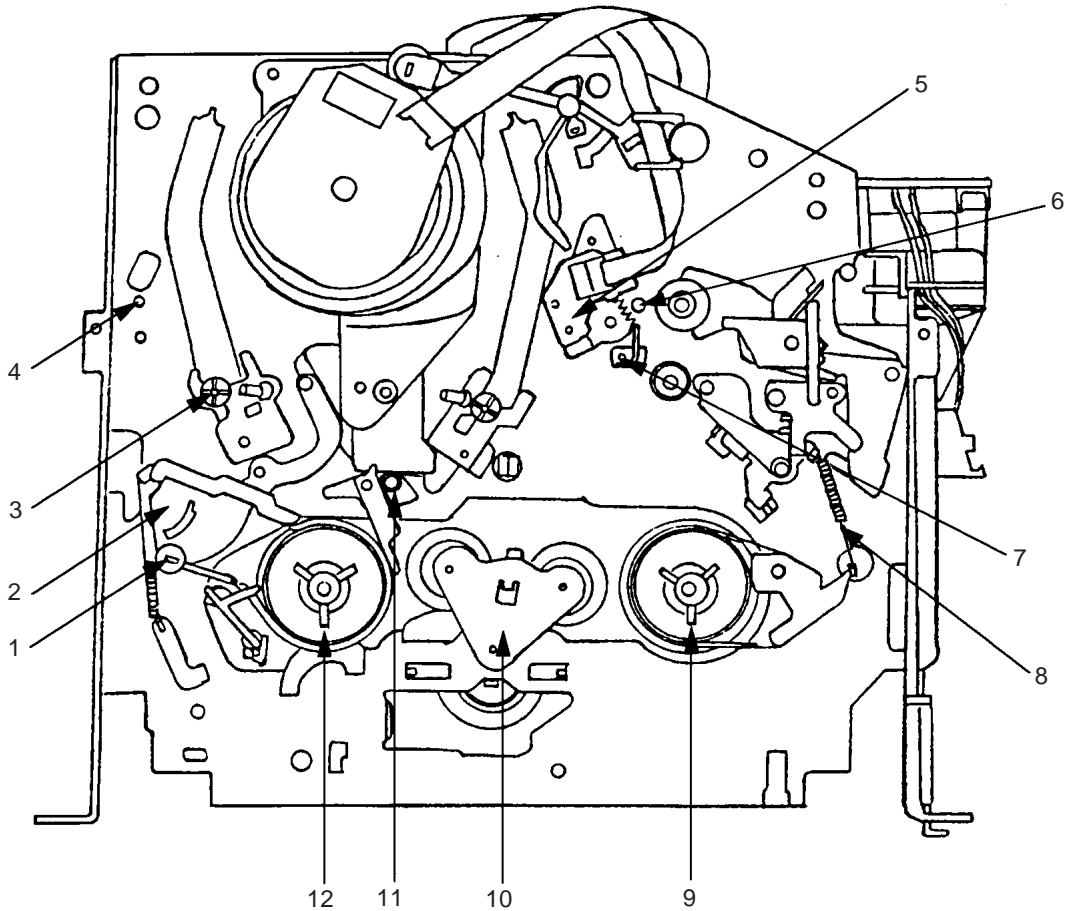

- | | |
|-----------------------------------|----------------------|
| 1. Tension Adjust | 7. P4 Post |
| 2. Tension Arm | 8. T Brake Spring |
| 3. Guide Roller | 9. T Reel Ass'y |
| 4. P1 Post | 10. Idler Ass'y |
| 5. Audio/Control Head | 11. S-S Brake Spring |
| 6. X value adjustment driver hole | 12. S Reel |

ELECTRICAL ADJUSTMENTS

Read and perform this adjustment when repairing the circuits or replacing electrical parts or PCB assemblies.

1. BASIC ADJUSTMENT

CAUTION

When replacing IC's or transistors, use only specified silicon grease (**YG6260M**).
(To prevent the damage to IC's and transistors.)

1-1: PG SHIFTER

CONDITIONS

MODE-PLAYBACK
Input Signal-Alignment Tape (**JG001C**)

INSTRUCTIONS

1. Connect CH-1 on the oscilloscope to **TP4001** and CH-2 to **pin 19 of J4501**.
2. Playback the alignment tape. (**JG001C**)
3. Press and hold the Tracking-Auto button on the remote control more than 2 seconds to set tracking to center.
4. Press both CH UP button and STOP button on the set for more than 2 seconds. If the indicator ATR disappears, the adjustment is finished. (Refer to Fig. 1-1-A, B)

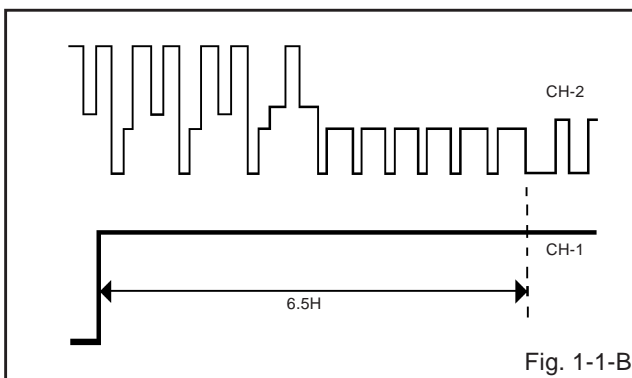
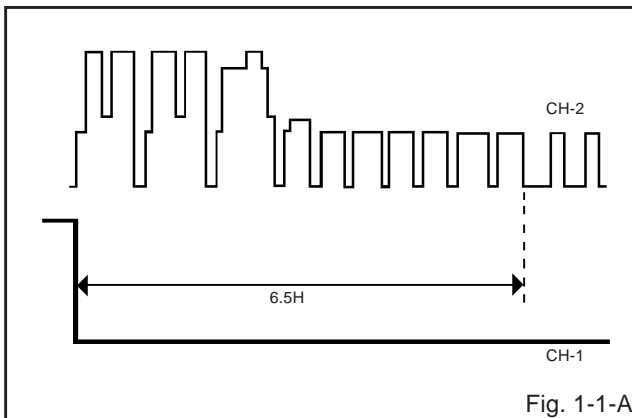

ELECTRICAL ADJUSTMENTS

2. ELECTRICAL ADJUSTMENT PARTS LOCATION GUIDE

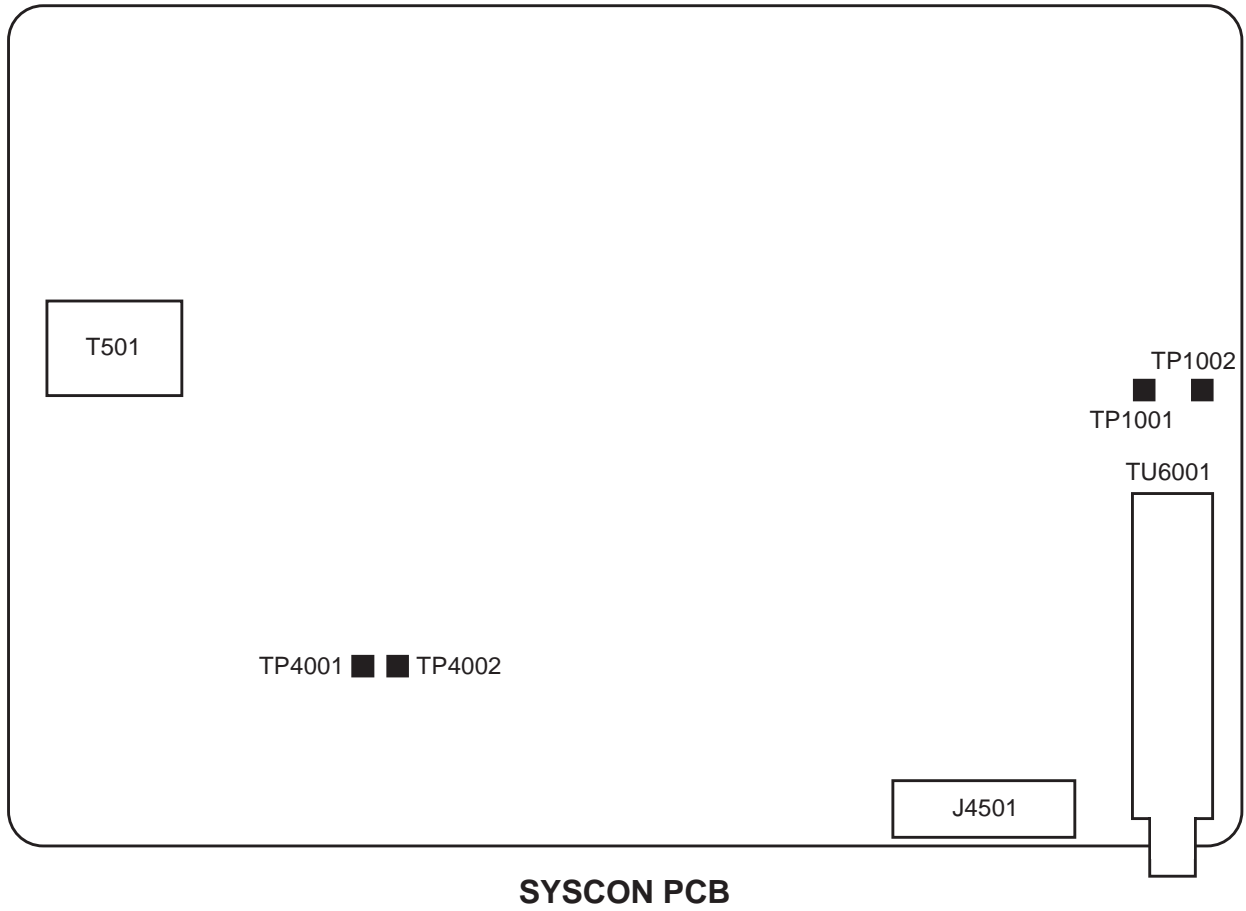

TROUBLESHOOTING GUIDE

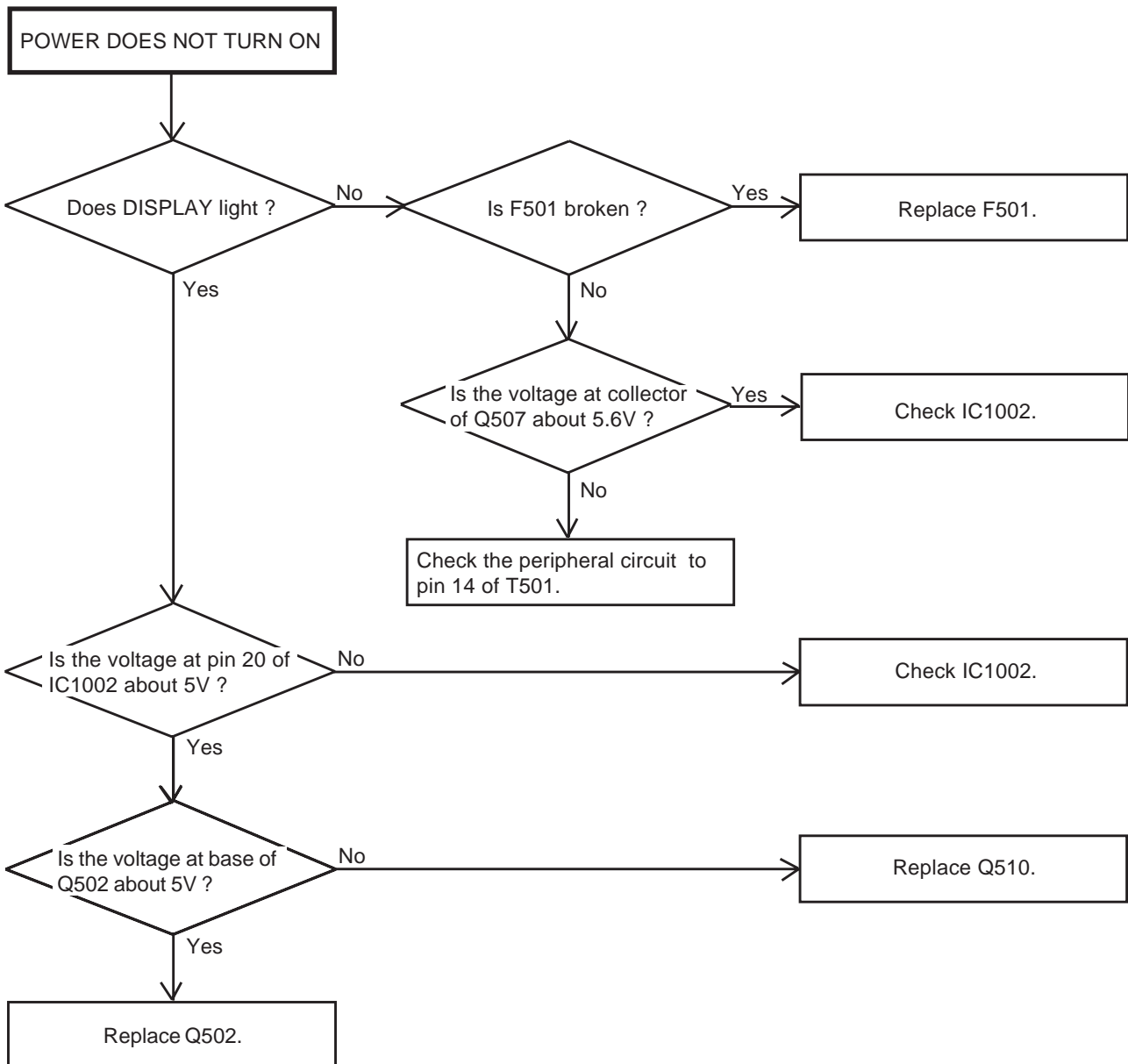

TROUBLESHOOTING GUIDE

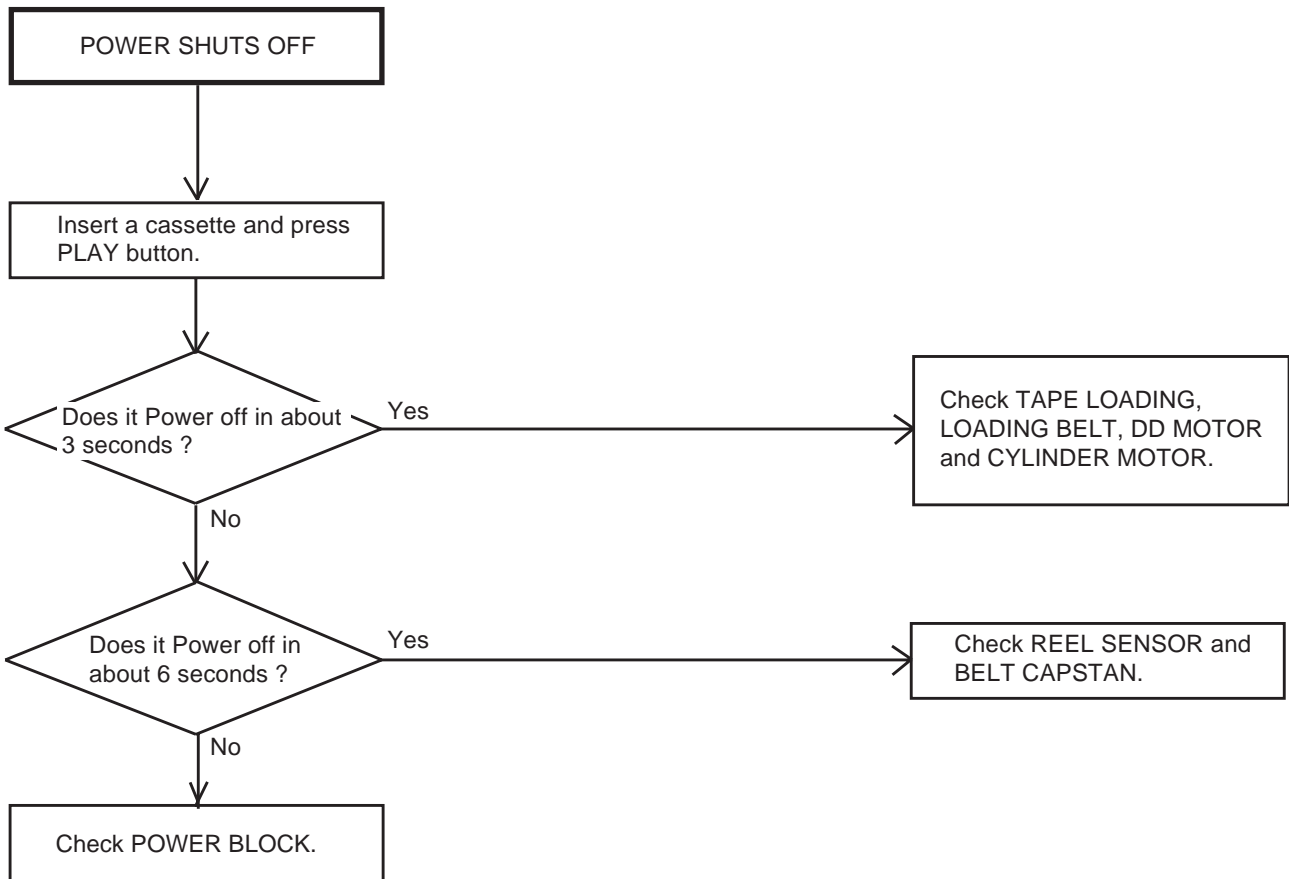

TROUBLESHOOTING GUIDE

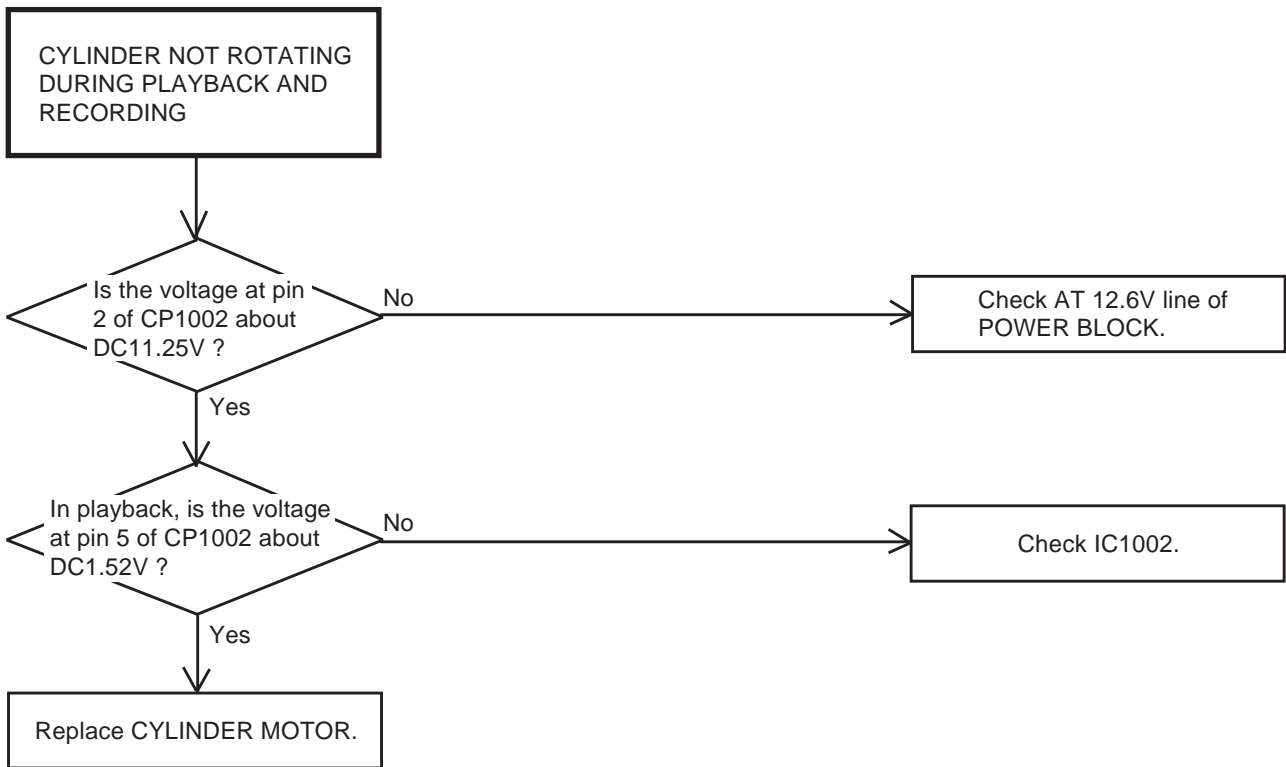

TROUBLESHOOTING GUIDE

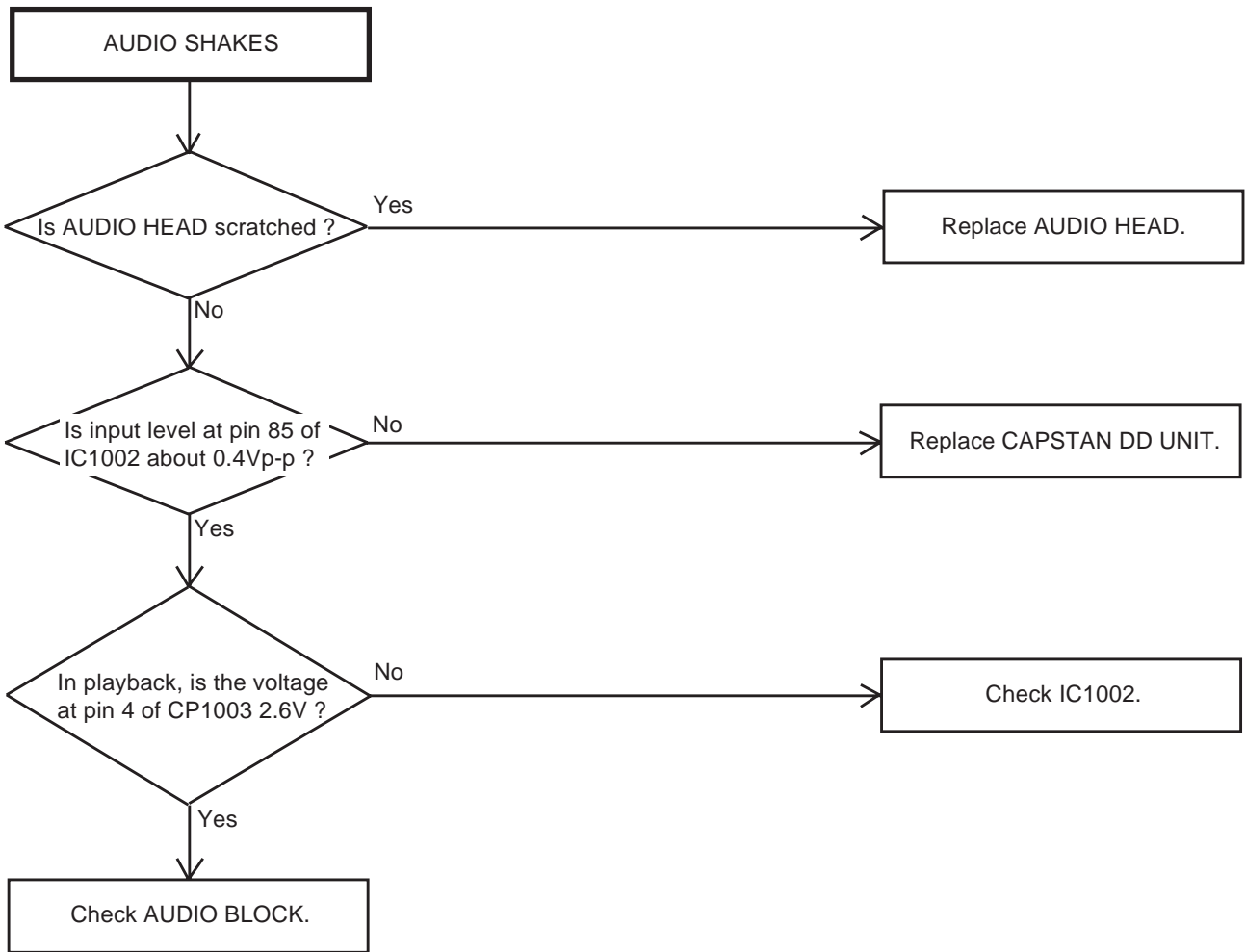

TROUBLESHOOTING GUIDE

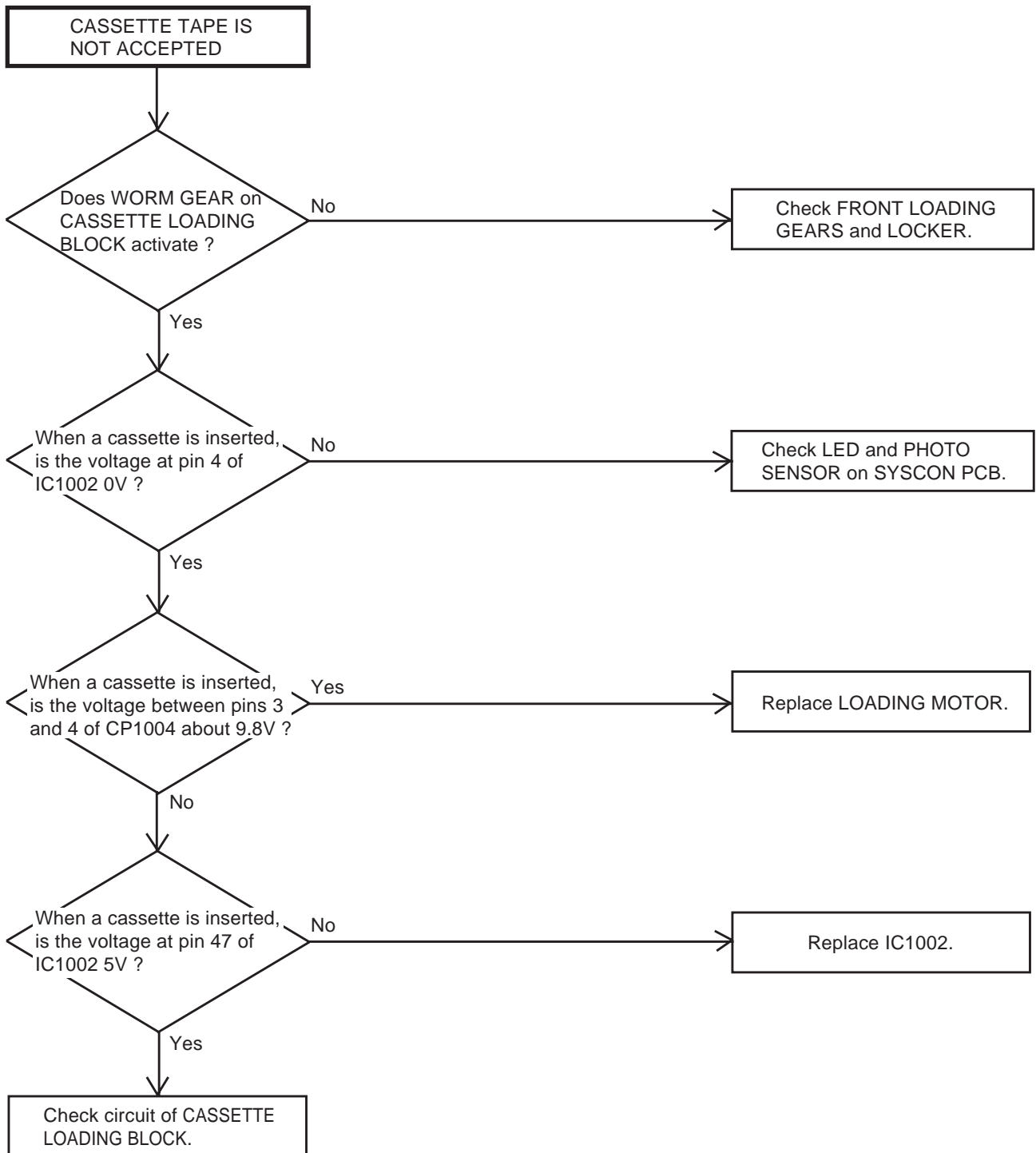

TROUBLESHOOTING GUIDE

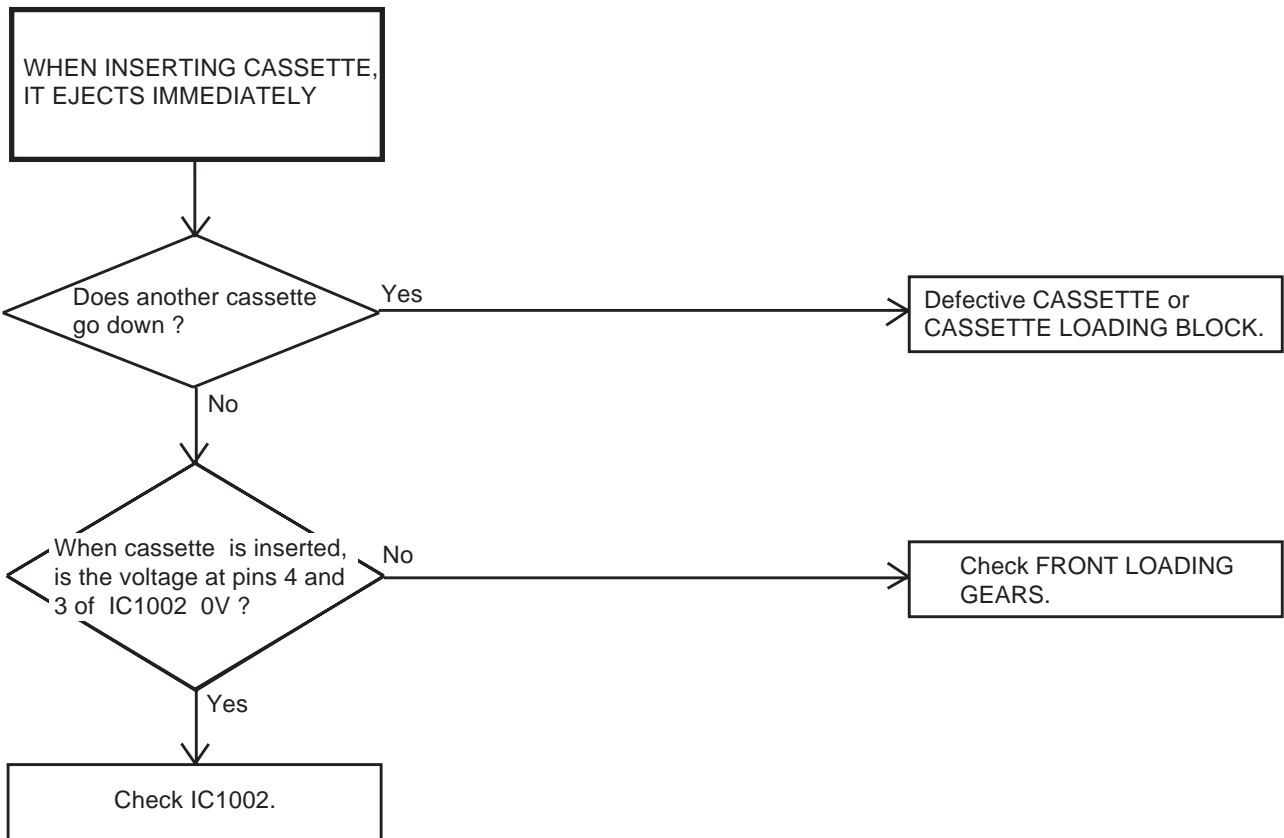

TROUBLESHOOTING GUIDE

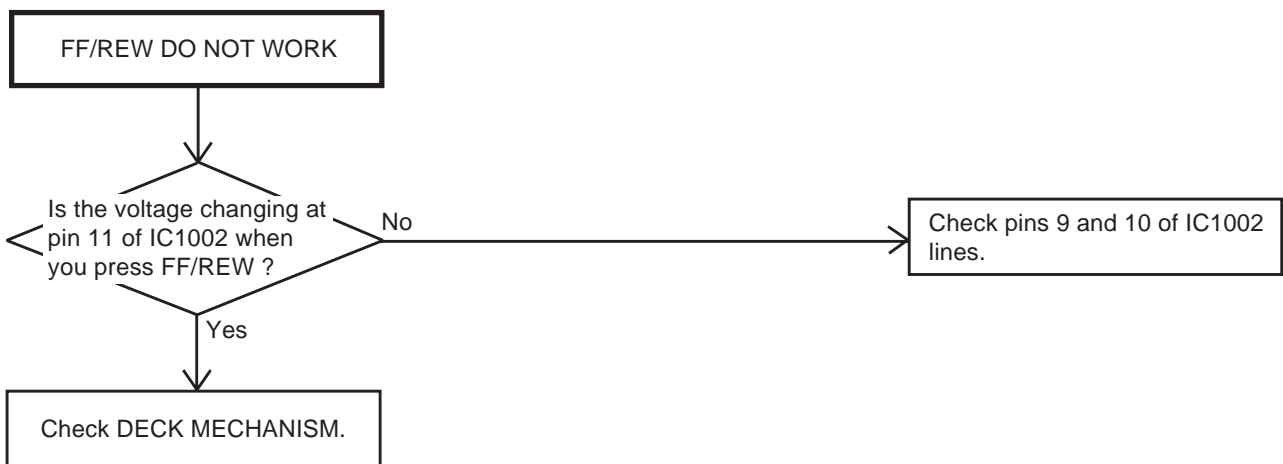

TROUBLESHOOTING GUIDE

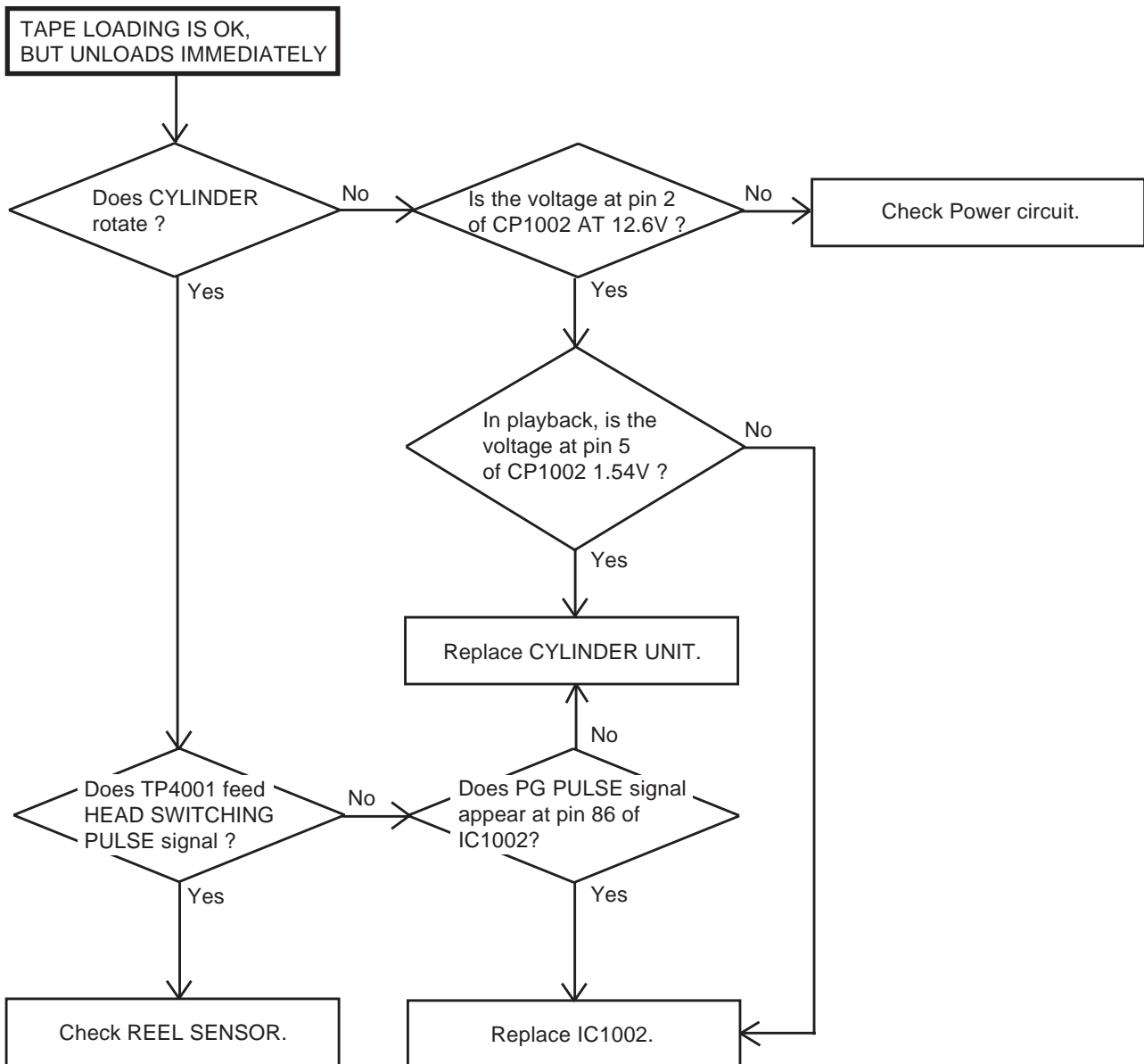

TROUBLESHOOTING GUIDE

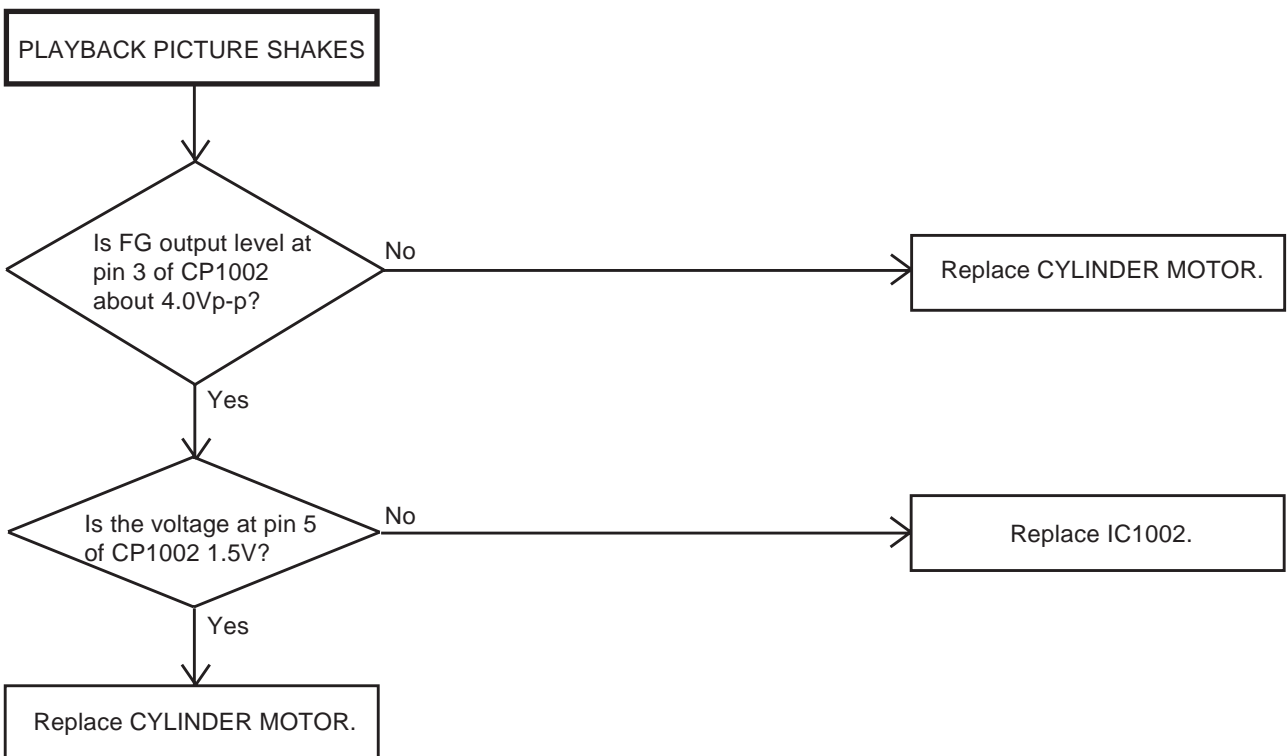
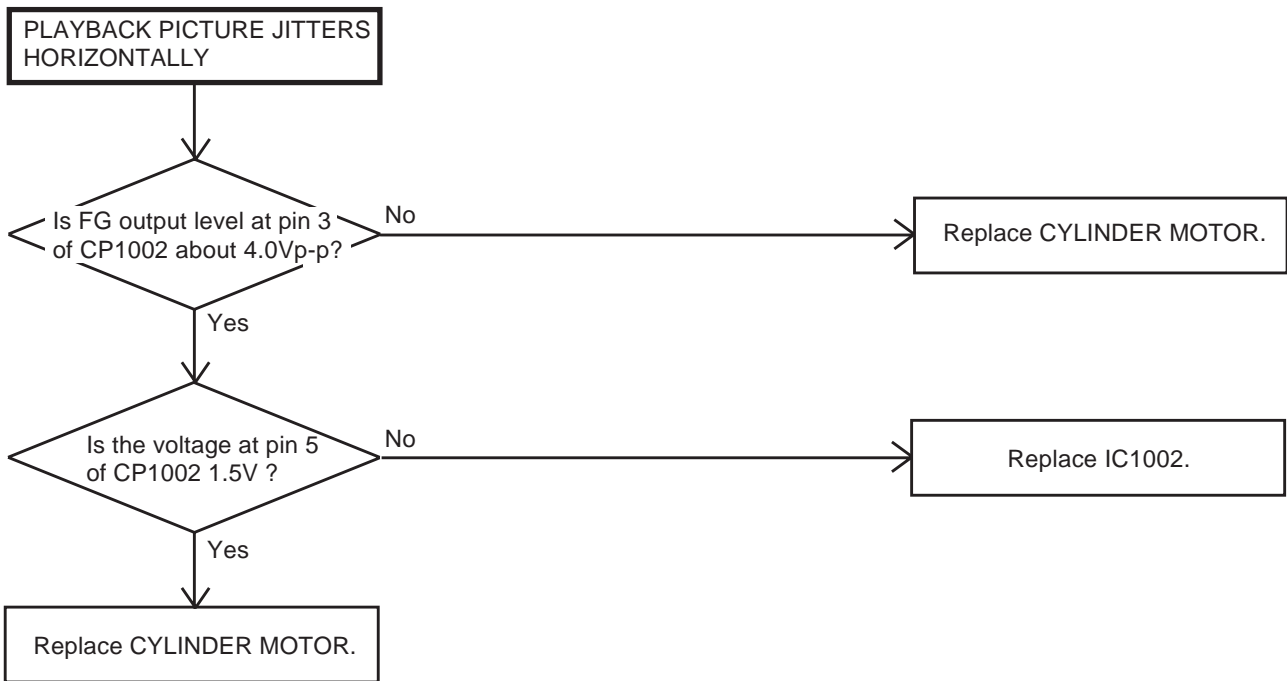

TROUBLESHOOTING GUIDE

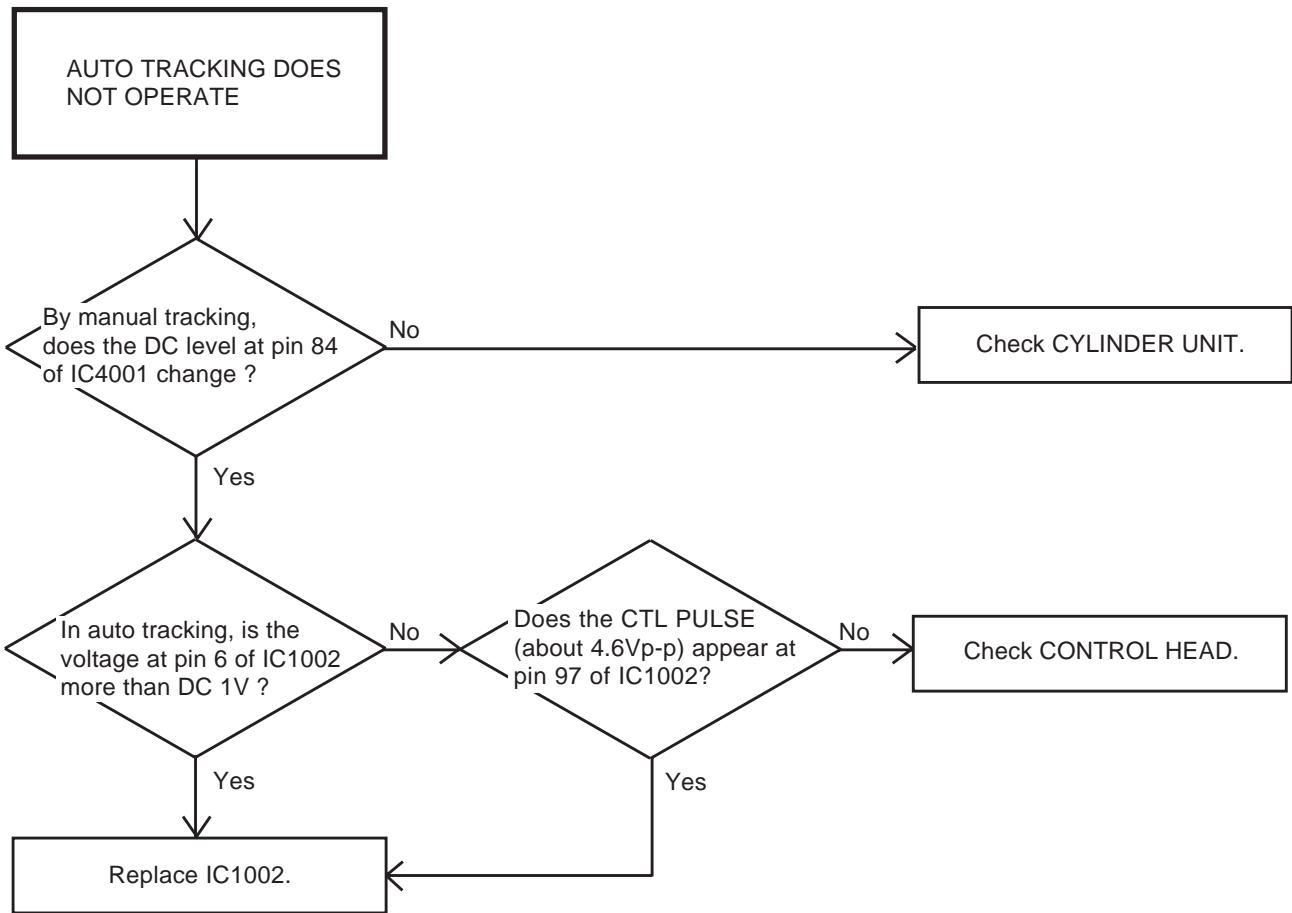

TROUBLESHOOTING GUIDE

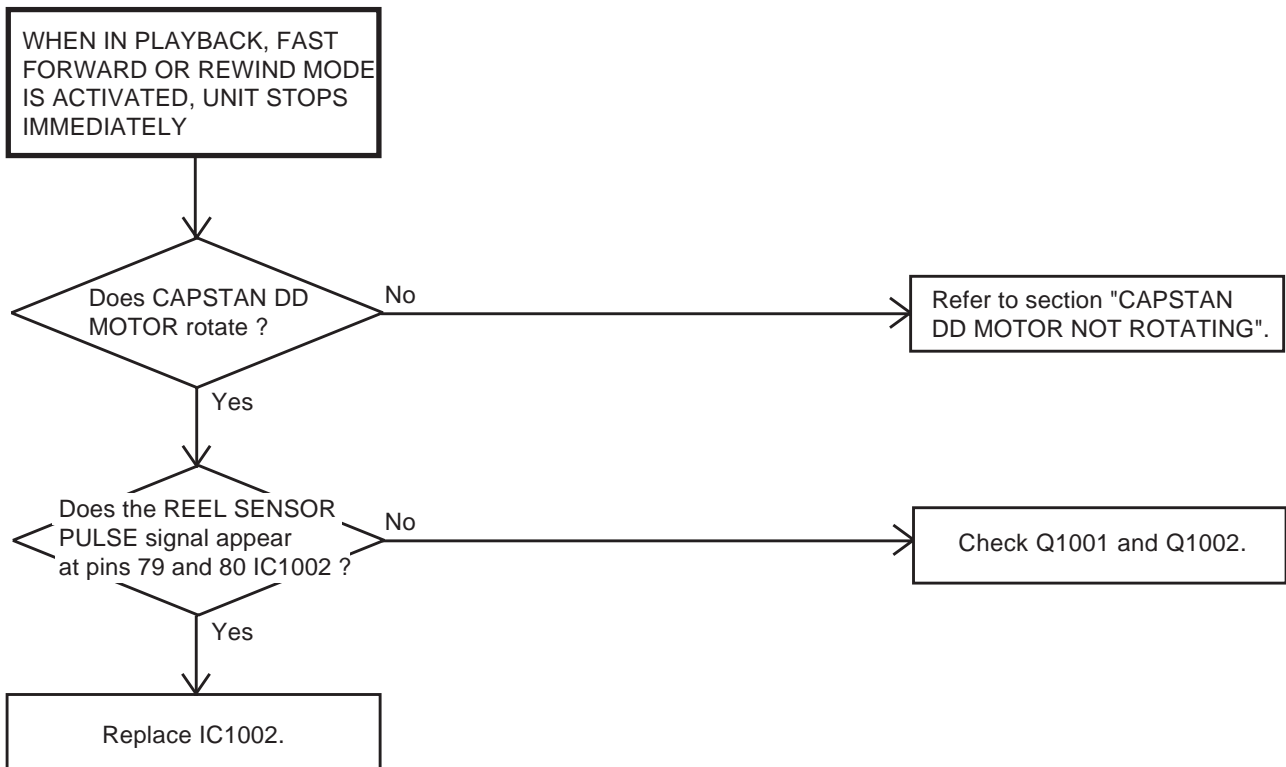

TROUBLESHOOTING GUIDE

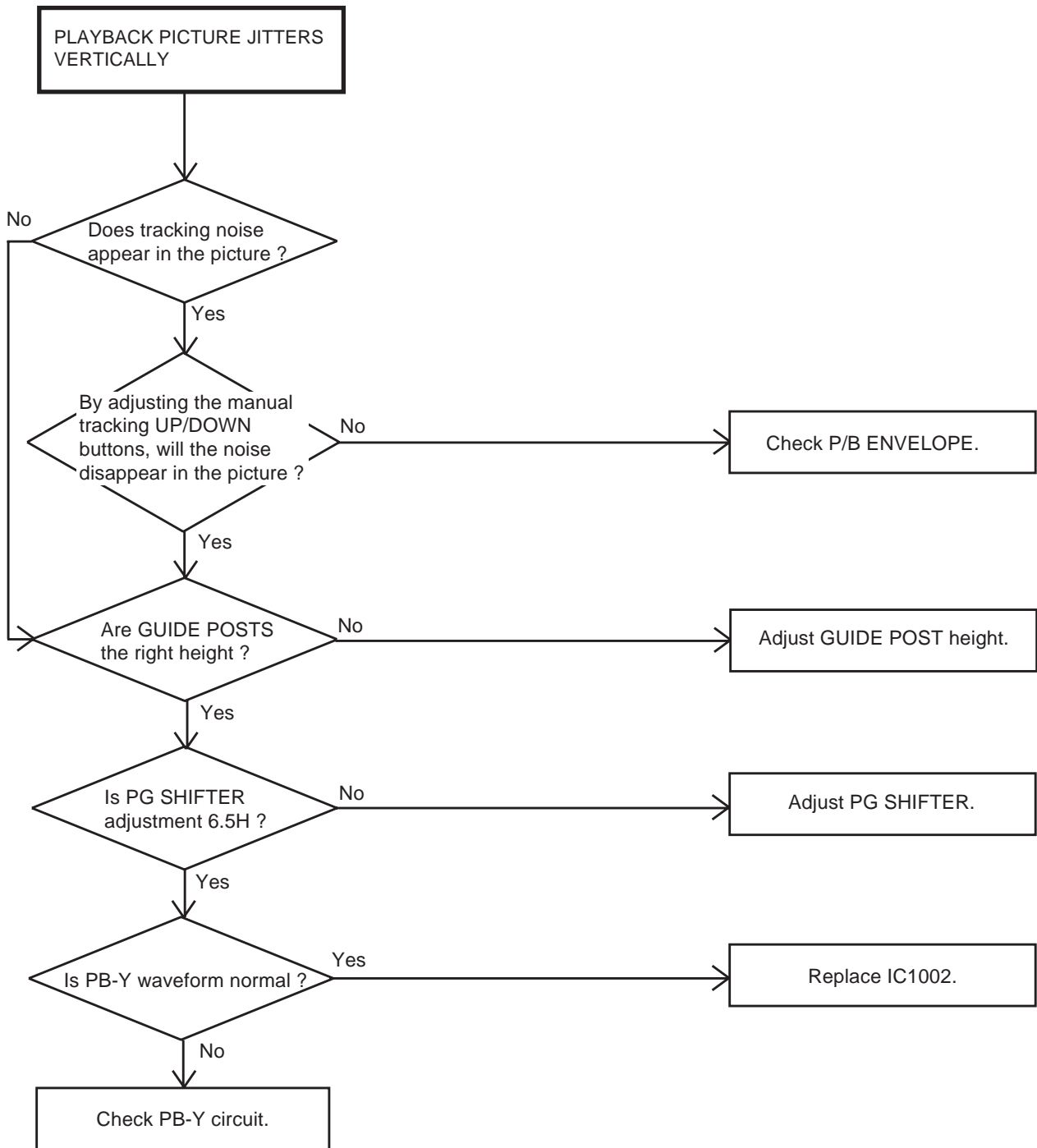

TROUBLESHOOTING GUIDE

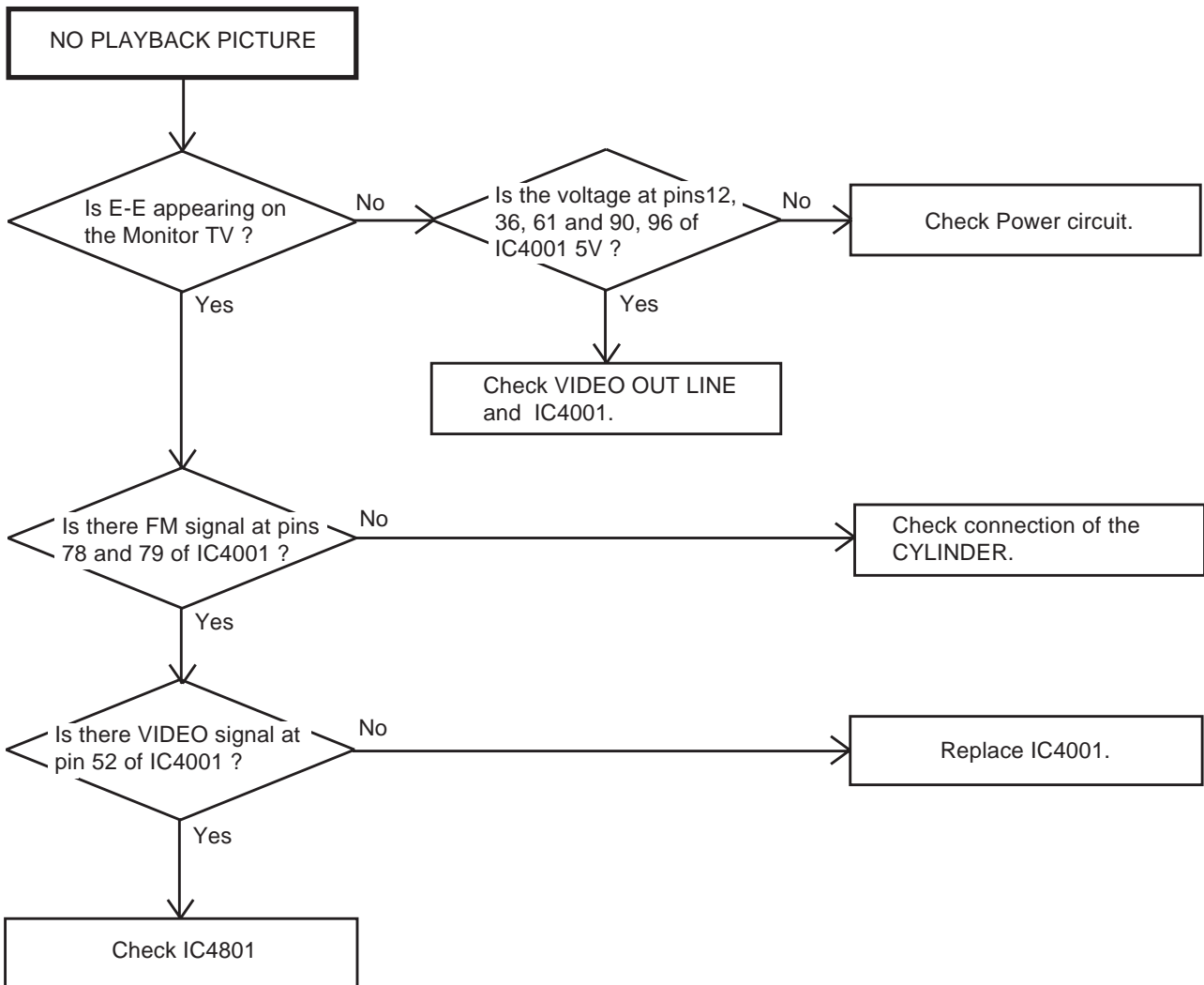

TROUBLESHOOTING GUIDE



TROUBLESHOOTING GUIDE

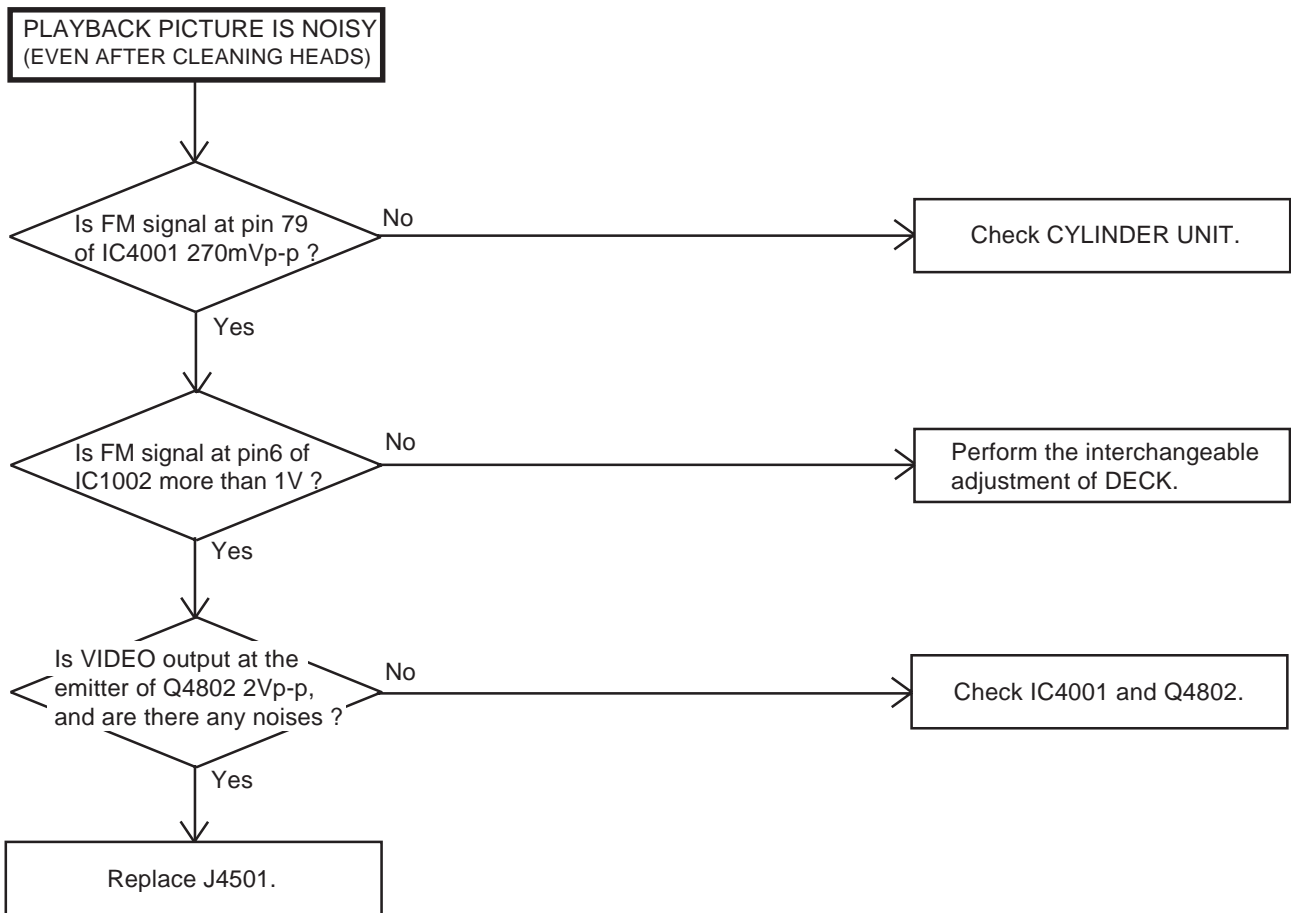

TROUBLESHOOTING GUIDE

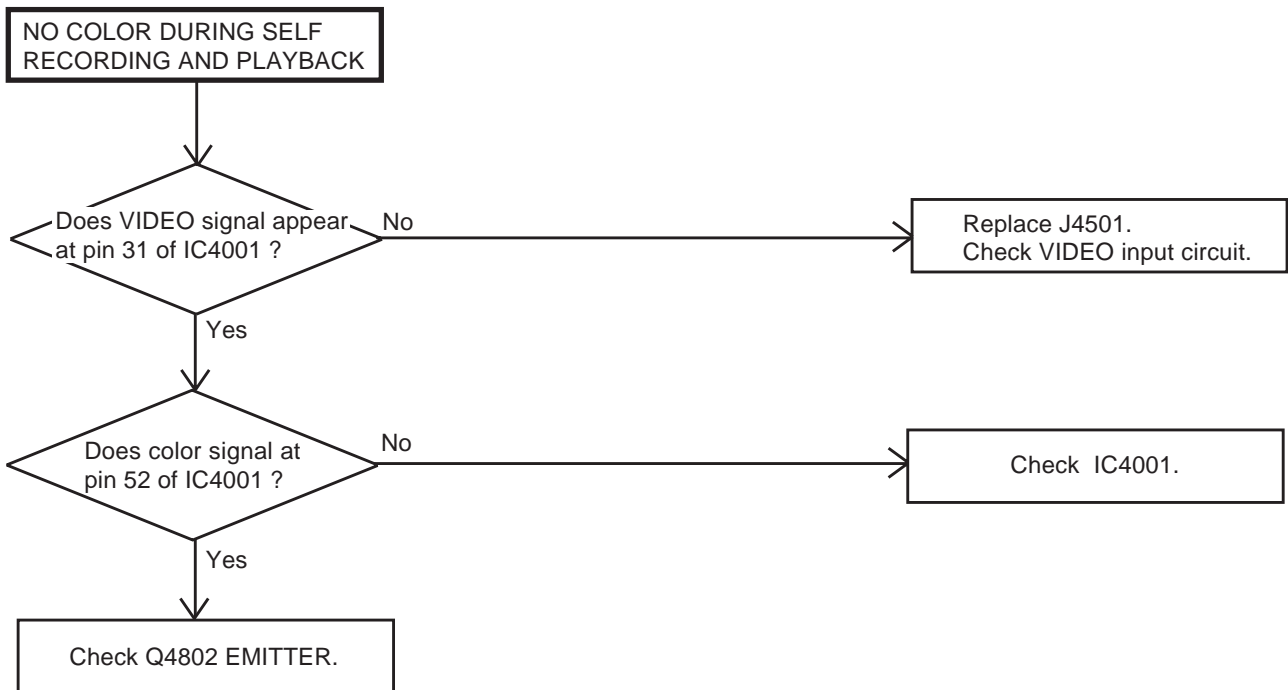

TROUBLESHOOTING GUIDE

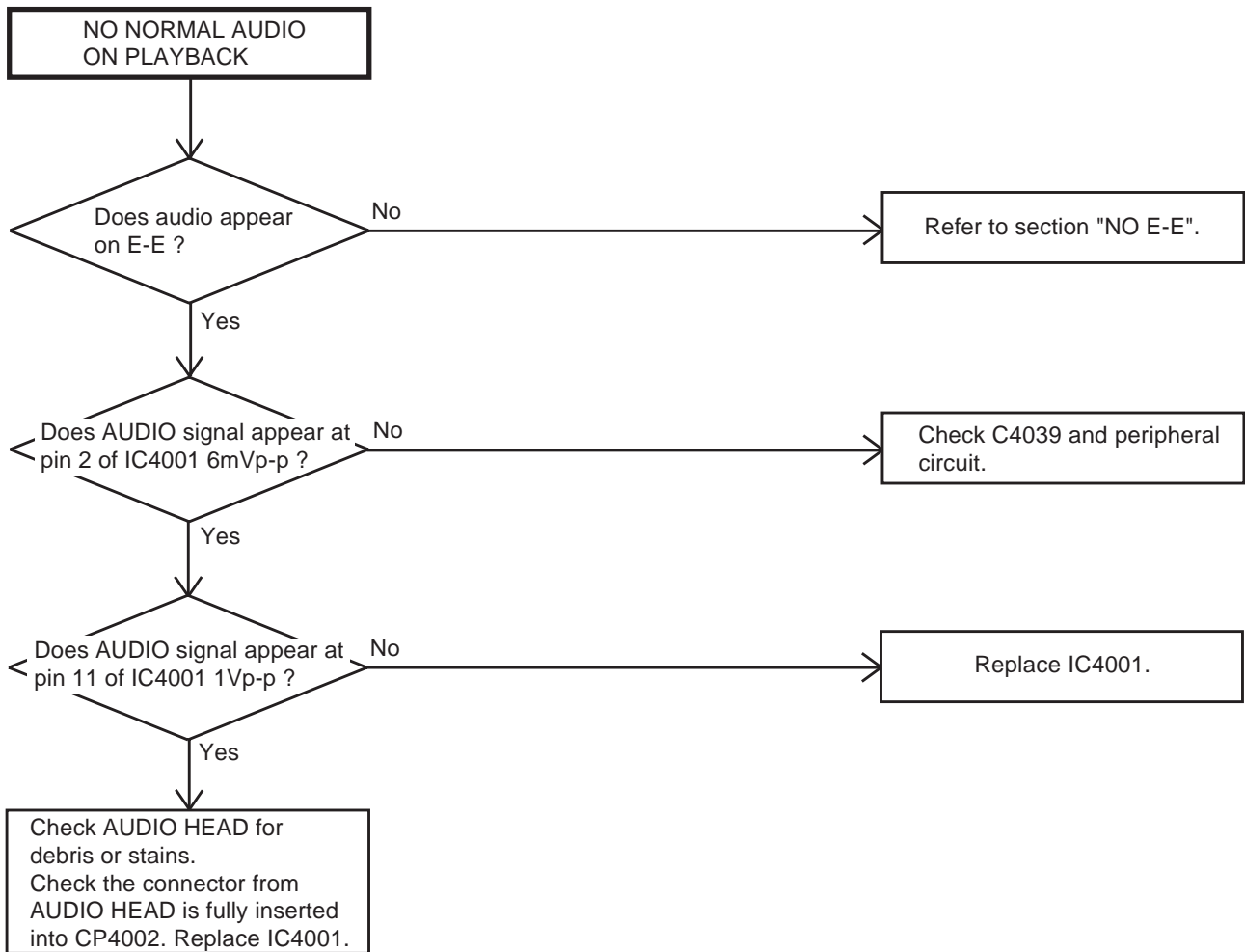

TROUBLESHOOTING GUIDE

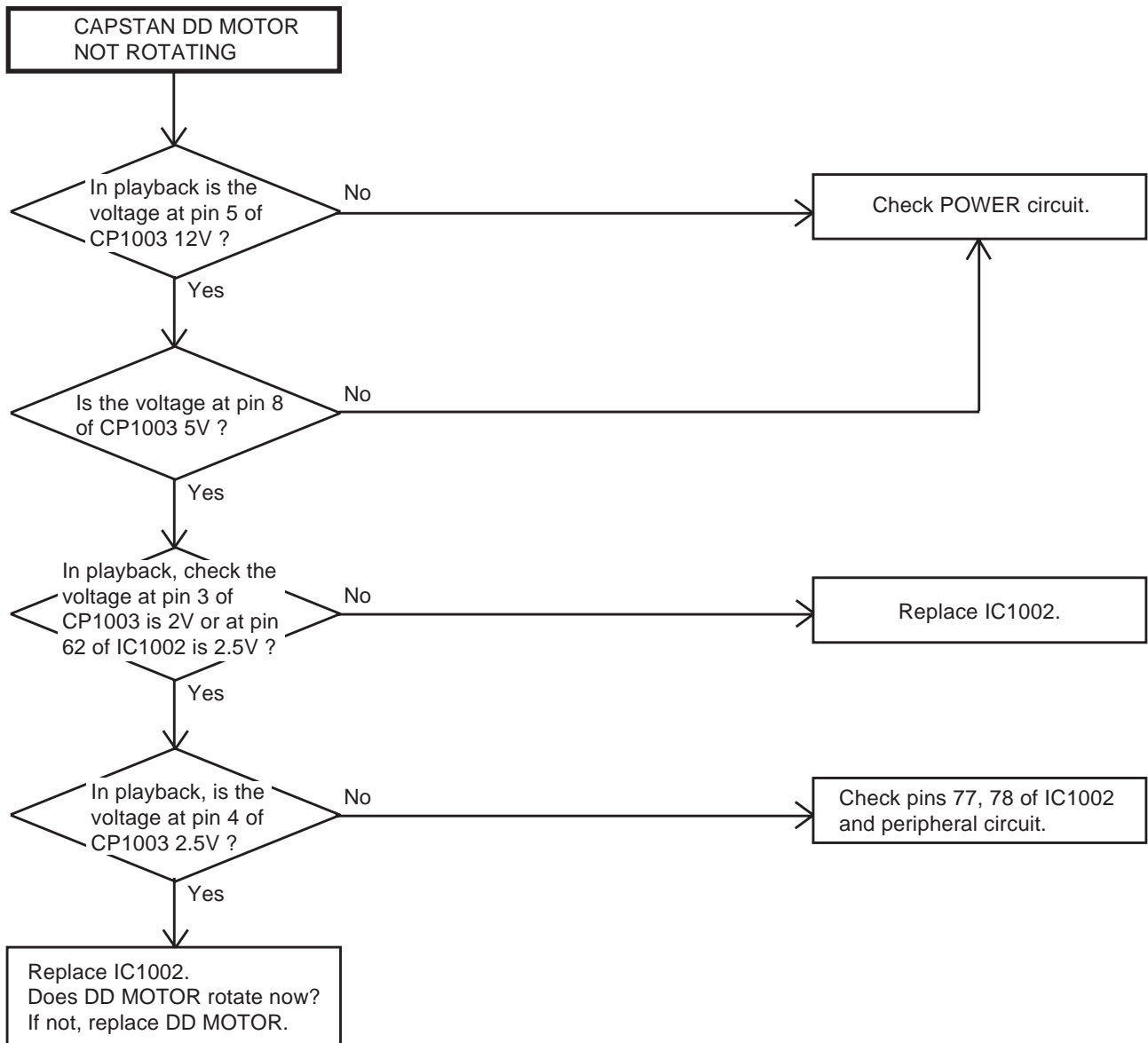

TROUBLESHOOTING GUIDE

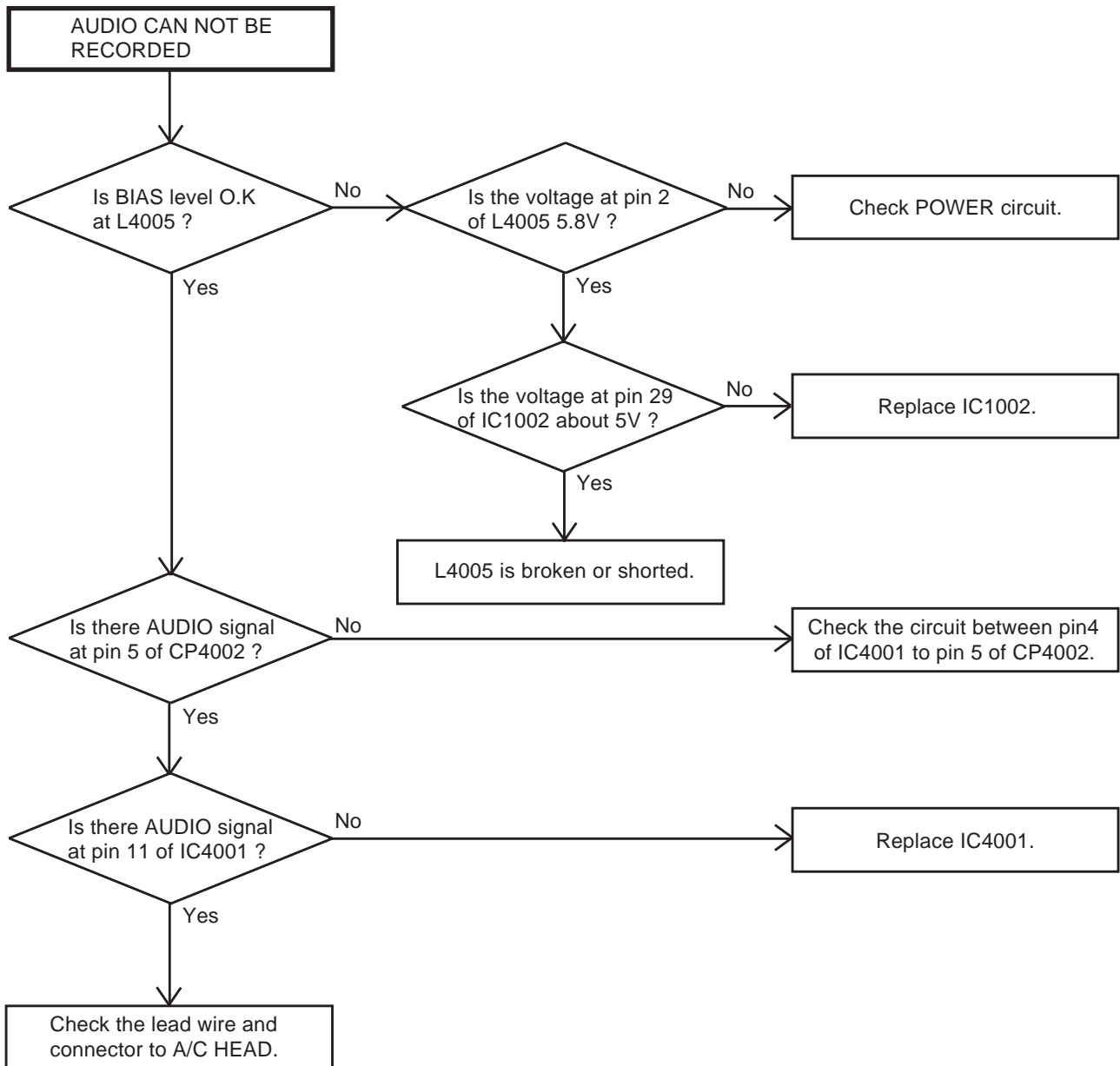

TROUBLESHOOTING GUIDE

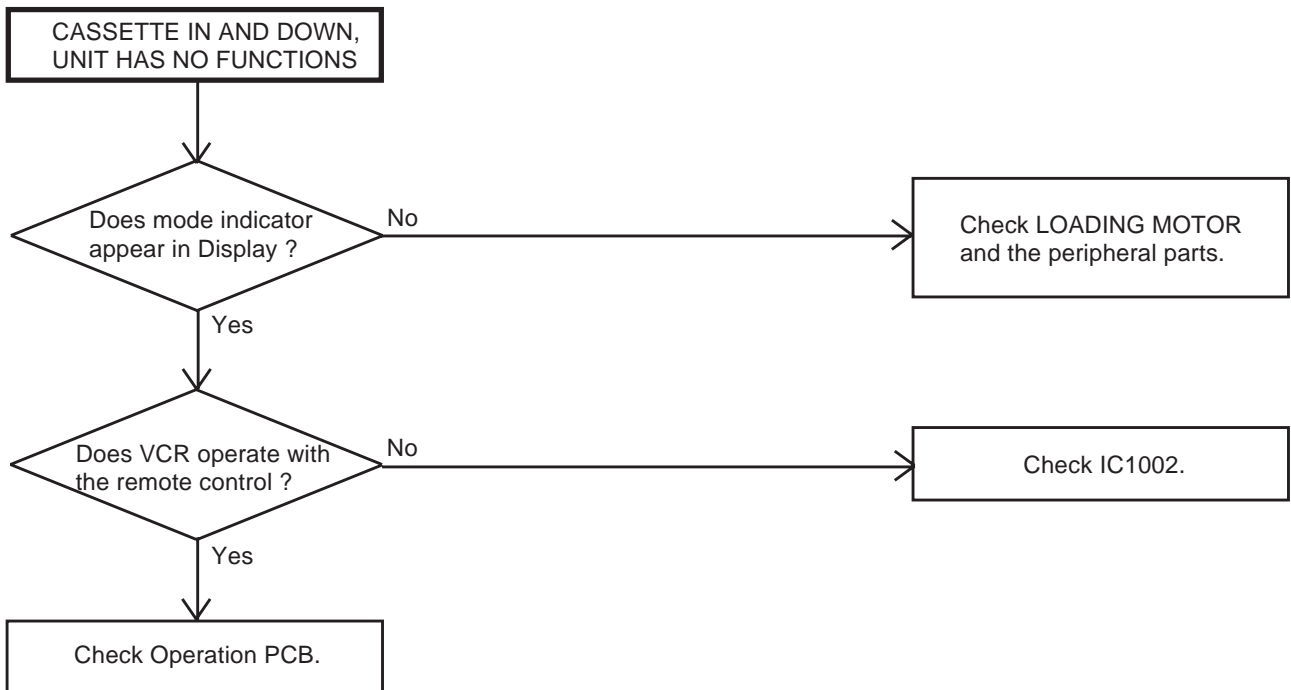

TROUBLESHOOTING GUIDE

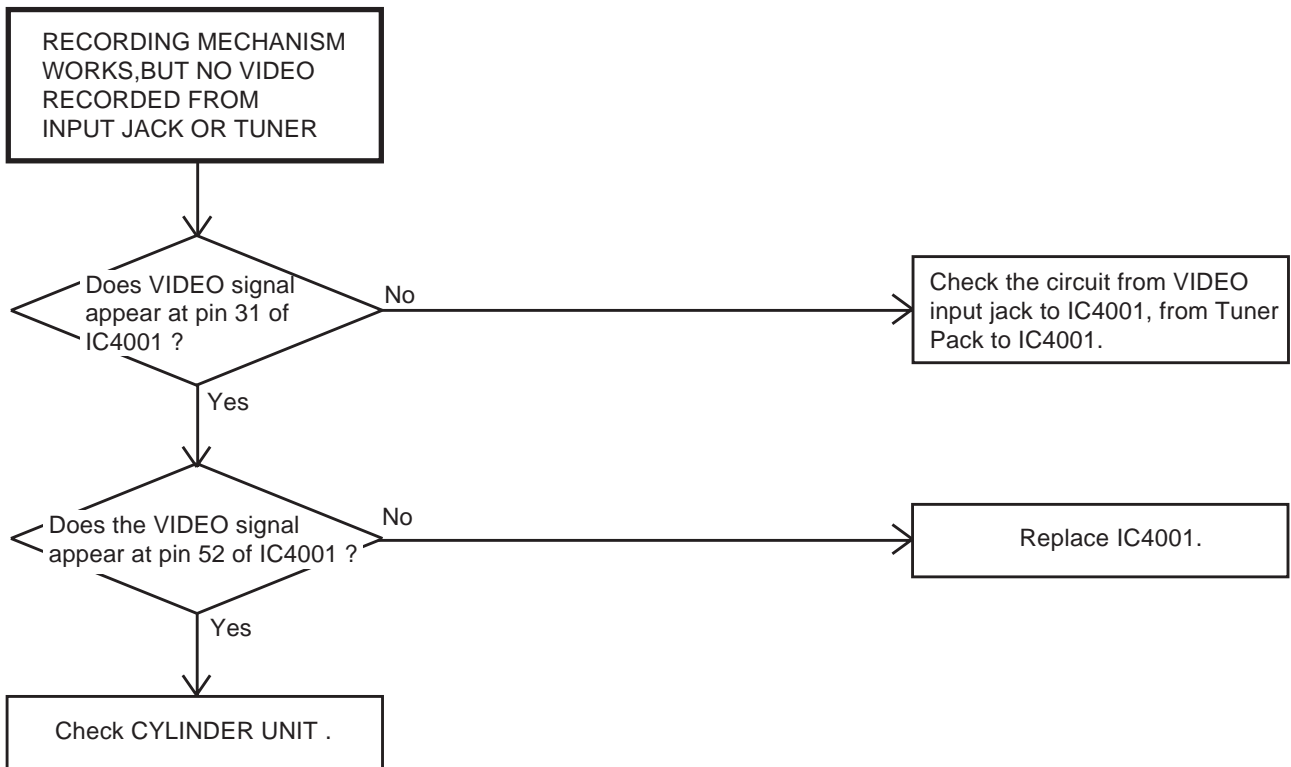

TROUBLESHOOTING GUIDE

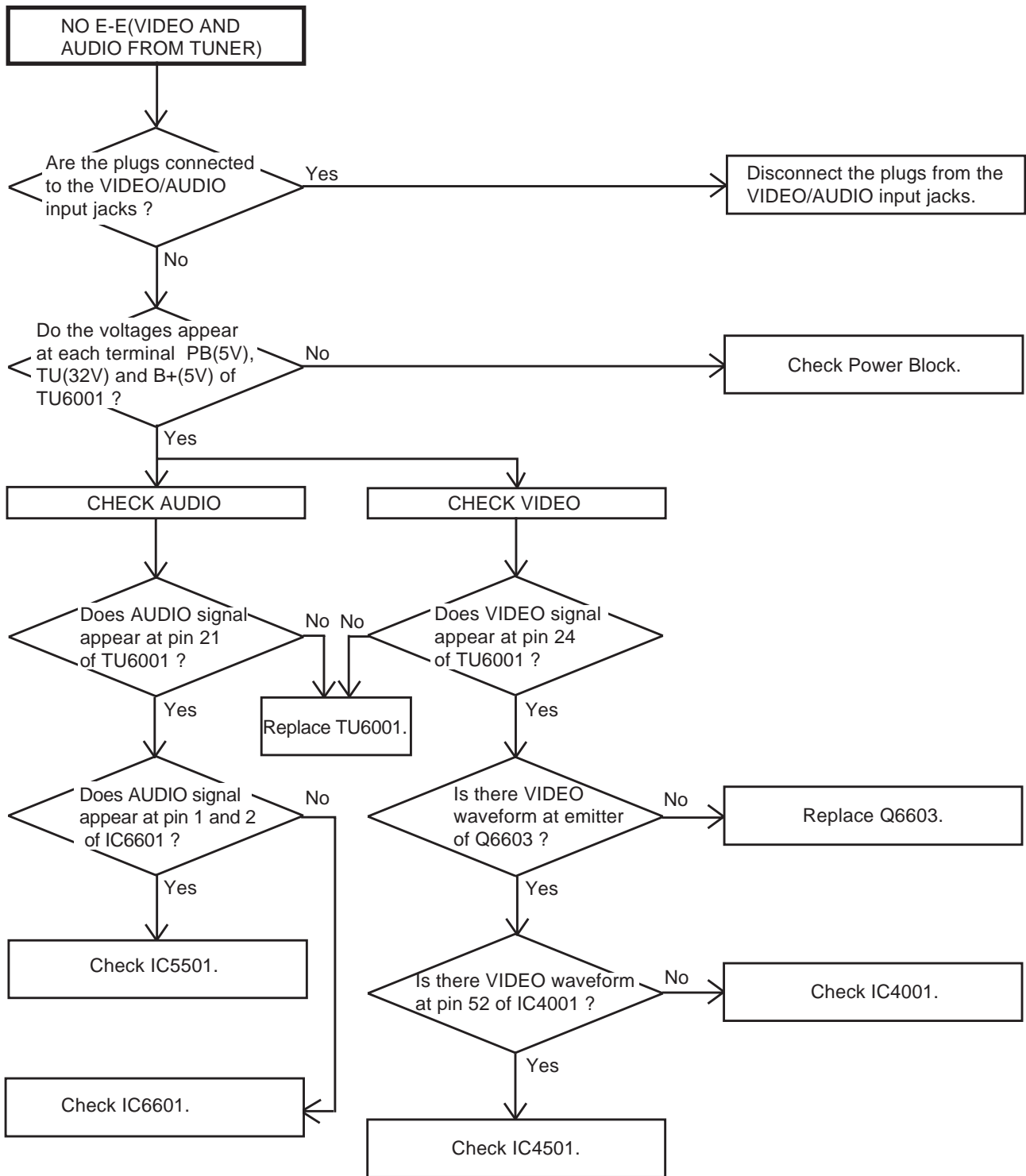

TROUBLESHOOTING GUIDE

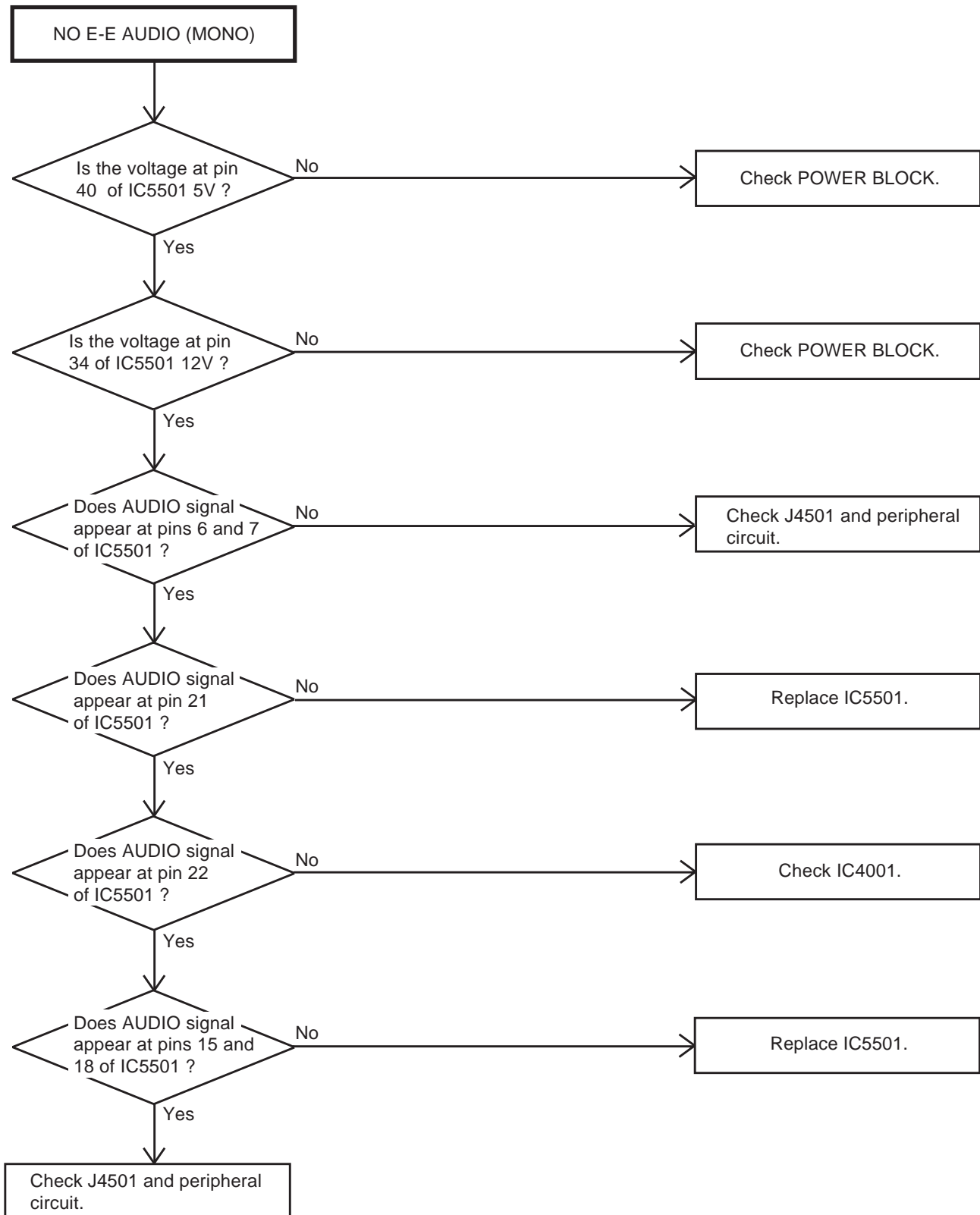

TROUBLESHOOTING GUIDE

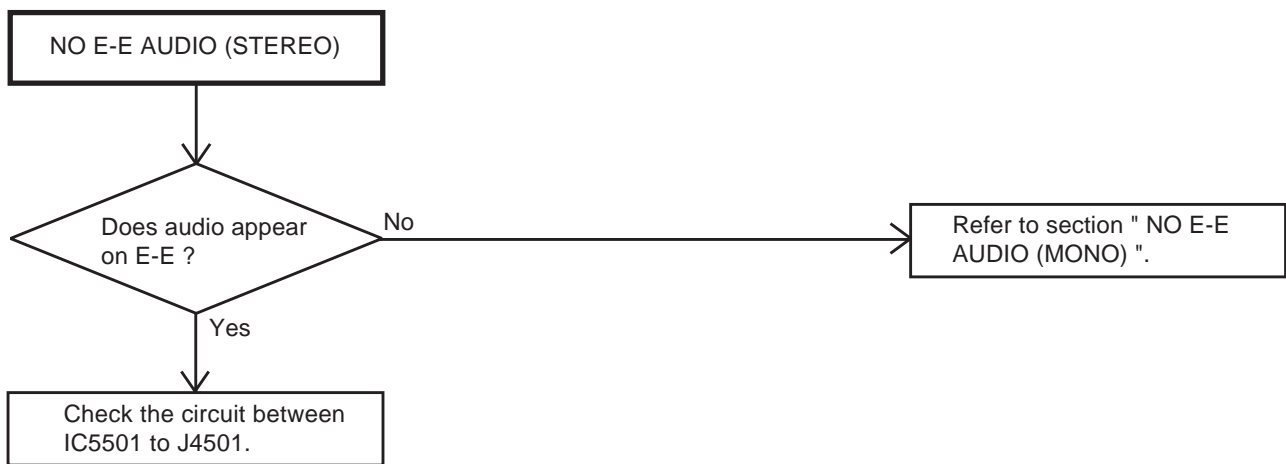

TROUBLESHOOTING GUIDE

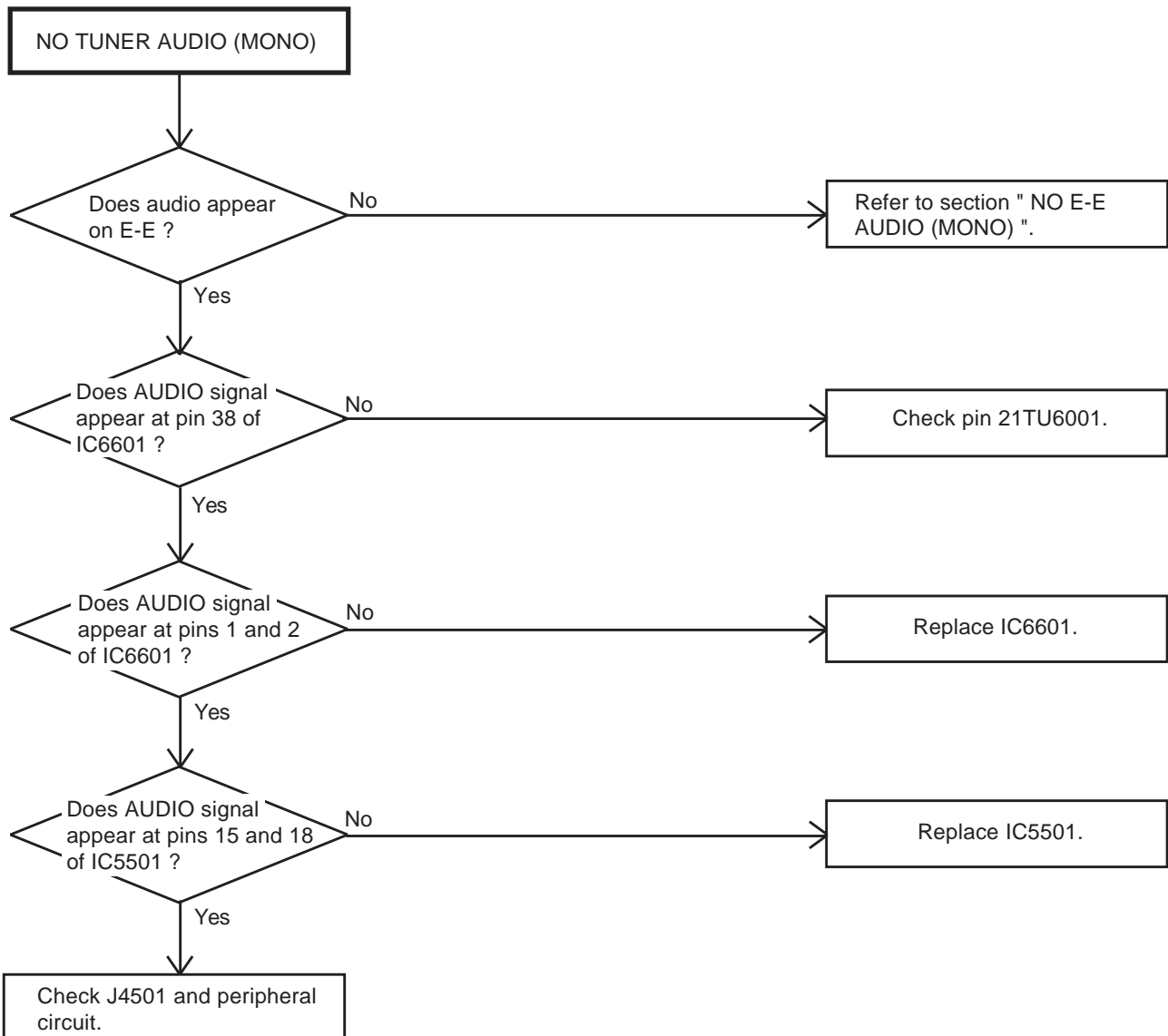

TROUBLESHOOTING GUIDE

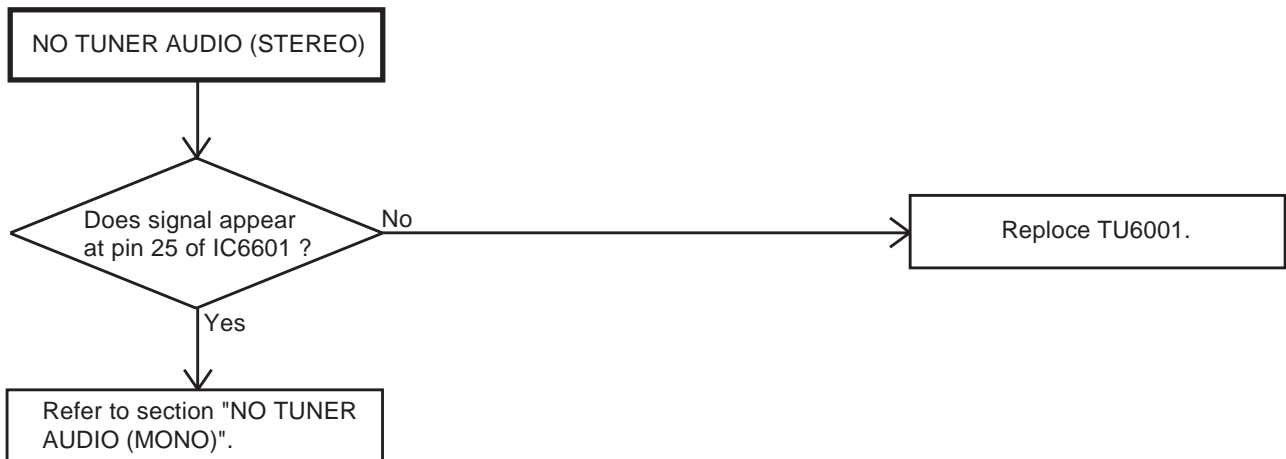

TROUBLESHOOTING GUIDE

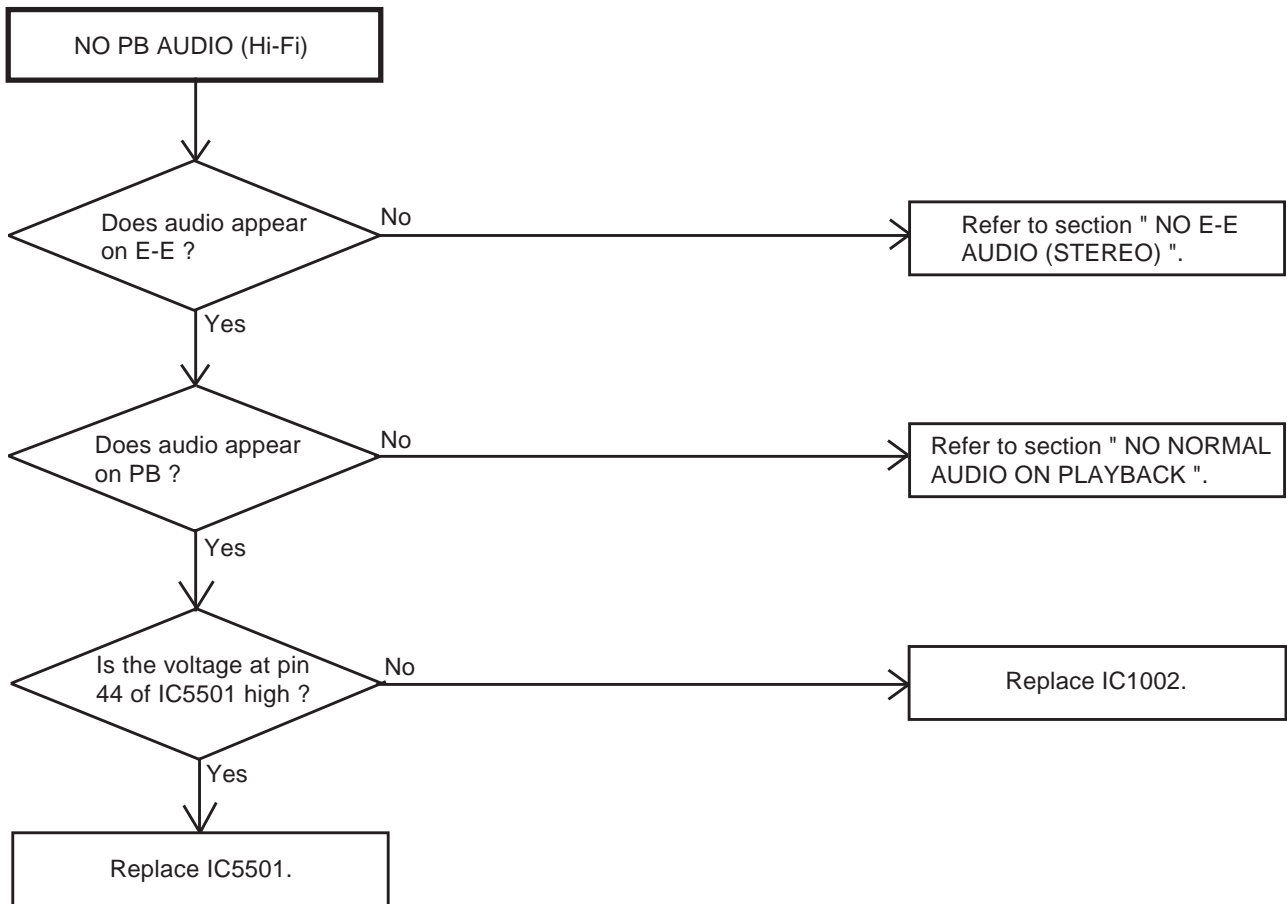

TROUBLESHOOTING GUIDE

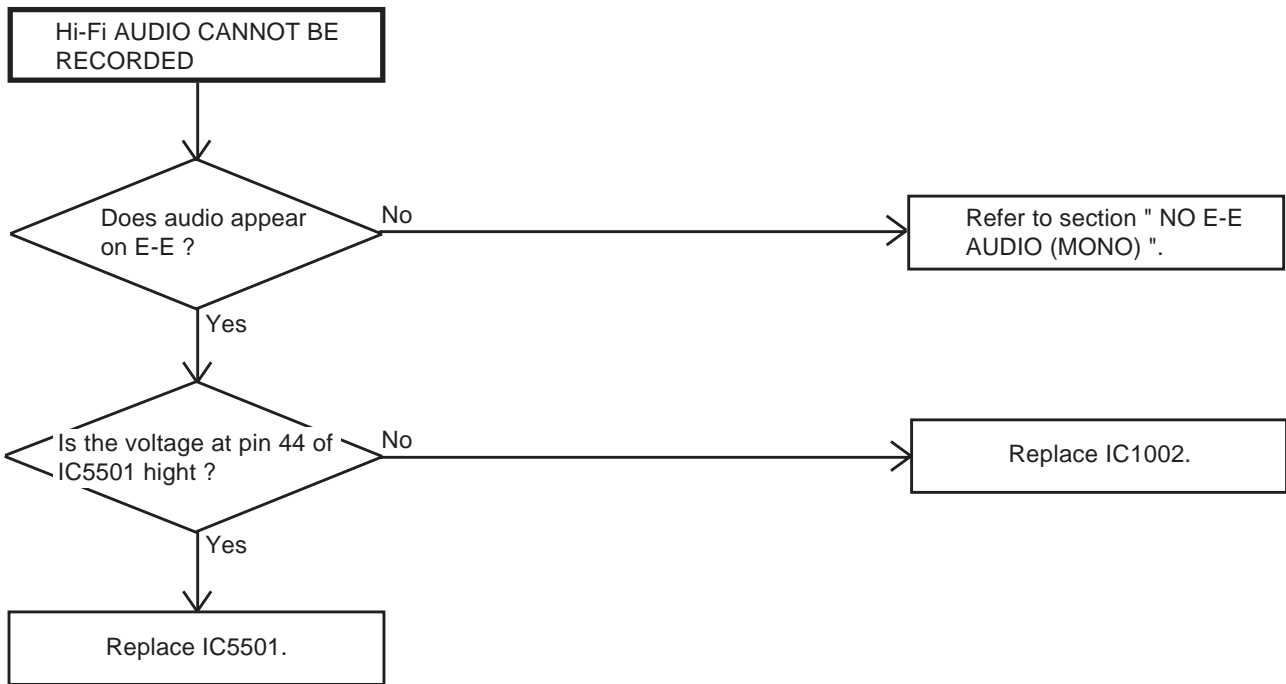

IC DESCRIPTIONS

OEC7035A

Pin No.	Pin Name	I/O	Description
1	AFT-SC	I	AFT S Curve input for tuner.
2	AGC-DET	I	Input of CASS DOWN, TAB switch and setting of service mode.
3	EOT	I	Tape end sensor input signal.
4	BOT	I	Tape start sensor input signal.
5	RF SW/A-ENV	I	Ground.
6	V-ENV	I	Input terminal of video RF envelope.
7	KEY-A	I	Key A input.
8	KEY-B	I	Key B input.
9	MSSW A	O	Input terminal (A) of mecha state sensor.
10	MSSW B	O	Input terminal (B) of mecha state sensor.
11	CAP FWD	O	Capstan forward and backward command.
12	CAP LIMIT	O	Switch the maximum output current of the Capstan Motor.
13	D.V SYNC	O	Imitative V-SYNC signal output during the special playback.
14	REMOCON	I	Input the infrared remote control.
15	NC	O	Not used.
16	NC	O	Not used.
17	NC	I	Not used.
18	V.HEAD SW	O	Output terminal of Head Switch.
19	A.HEAD SW	O	Not used.
20	POWER ON A H	O	For control the user power switch ON/OFF.
21	NC	O	Not used.
22	SENS LED	O	Mecha state sensor LED.
23	NC	O	Not used.
24	NC	O	Not used.
25	FF/REW L	O	Output "L" when fast forwarding or rewinding.
26	CAP MID-H	O	Power of Capstan Motor select.
27	CAP HI-H	O	Power of Capstan Motor select.
28	HEATER SW	O	-30V ON/OFF Control.
29	NA REC-H	O	Control the Bias OSC for audio head.
30	VV-H	O	Not used.
31	SERVICE 1	I	Setting of service mode 1.
32	SP STILL H	O	Not used.
33	NC	O	Not used.
34	NC	-	Not used.
35	NC	-	Not used.
36	CLKSEL	-	5V.
37	VCC	-	5V.
38	X IN	I	Connect the main crystal(12 MHz).
39	X OUT	O	Connect the main crystal(12 MHz).
40	VSS	-	Ground.
41	XC IN	I	Subclock pulse(32.768 KHz).
42	XC OUT	O	Subclock pulse(32.768 KHz).
43	RESET	I	Input terminal of reset signal.
44	NC	O	Not used.
45	NC	O	Not used.
46	I/O CTL	O	Control the Audio/Video input/output.
47	LDM FWD	O	Output signal to control the rotation direction of the Loading Motor.
48	LDM REV	O	Output signal to control the rotation direction of the Loading Motor.
49	NC	O	Not used.
50	RGB ON-H	O	If the EE/VV is "EE" or TV/VCR is "TV" and PELI CTRL-L is "L", H Output will appear. And the others, "L" Output will appear.

IC DESCRIPTIONS

OEC7035A

Pin No.	Pin Name	I/O	Description
51	POWER ON L	O	For control the user power switch ON/OFF.
52	NC	O	Not used.
53	ONE TOUCH PB	O	Control the LED for the ONE TOUCH PLAYBACK.
54	PELI CTL	I	Control the 21 pin IC output.
55	NC	O	Not used.
56	NC	O	Not used.
57	A.MUTE-H	O	This pin output the HIGH to mute the sound at the switching point between E-E and V-V during the special playback.
58	T.A.MUTE-H	O	Not used.
59	TAB SW	I	Input of TAB SW.
60	NC	I	Not used.
61	SD	O	Not used.
62	CAP ON	O	Control the Capstan Motor rotation direction.
63	CG-CS	O	Output the CS signal of character generator IC.
64	FLD-CS	I	User switch for the auto start ON/OFF.
65	FLD-D OUT	O	Timing output of data transmission and receiving with FIP driver.
66	FLD-D IN	I	Receiving of Key switch data from FIP driver.
67	FLD-CLK	O	Indication data and mode transmission to FIP driver.
68	CG-DATA	O	Output the Data of OSD.
69	NC	I	Not used.
70	CG-CLK	O	Output the Clock of OSD.
71	IIC-CLK	O	Clock output to Hi-Fi IC.
72	IIC-SDA	I/O	DATA input/output to Hi-Fi IC.
73	32K MONI	O	Output 32.768KHz monitor(16.384KHz output) to check the clock.
74	Hi-Fi MUTE	O	Control the Hi-Fi IC.
75	V-REC-ST	O	Control the Head Amp for video and Hi-Fi audio.
76	PICTURE CTL	O	Output pulse to control the Y/C IC for sharpness.
77	CAP-CTL	O	Output servo of the capstan motor.
78	CYL-CTL	O	Output "L" when fast forwarding or rewinding.
79	REEL-S	I	Input terminal of reel sensor supply.
80	REEL-T	I	Input terminal of reel sensor take up.
81	NC	-	Not used.
82	P.FAIL	I	Input for the detection of power interruption.
83	NC	-	Not used.
84	C SYNC	I	Input Compound synchronized signal.
85	CFG	I	Input terminal for Capstan FG signal detection.
86	DPG	I	Input terminal for Drum PG signal detection.
87	DFG	I	Input terminal for Drum FG signal detection.
88	AMP VSS	-	Ground.
89	AMP V.OUT	O	Output the Analogue Amp standard voltage.
90	AMP V.IN	I	Input the Analogue Amp standard voltage.
91	CTL-	I/O	Input and output terminal of CTL AMP.
92	CTL+	I/O	Input and output terminal of CTL AMP.
93	CTL SW OUT	O	Output terminal of CTL AMP positive.
94	CTL AMP IN	I	Input terminal of CTL AMP.
95	AMP C	-	Ground.
96	CTL VSS	-	Connect the VSS.
97	CTL AMP OUT	I/O	Output terminal of CTL AMP circuit.
98	CTL VCC	-	5V.
99	A VCC	-	Voltage terminal for general circuit.
100	NC	I	Not used.

SERVO TIMING CHART

IC1001 (OEC7035A)

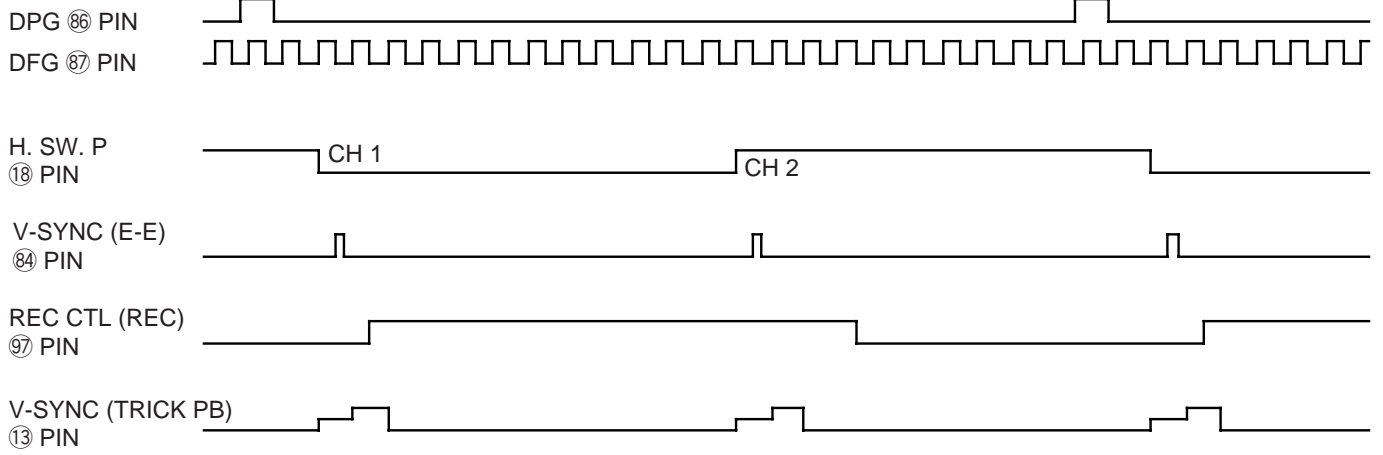

• WAVEFORM CHANGES DEPENDED ON THE TAPE SPEED

SYSTEM SWITCH MODE

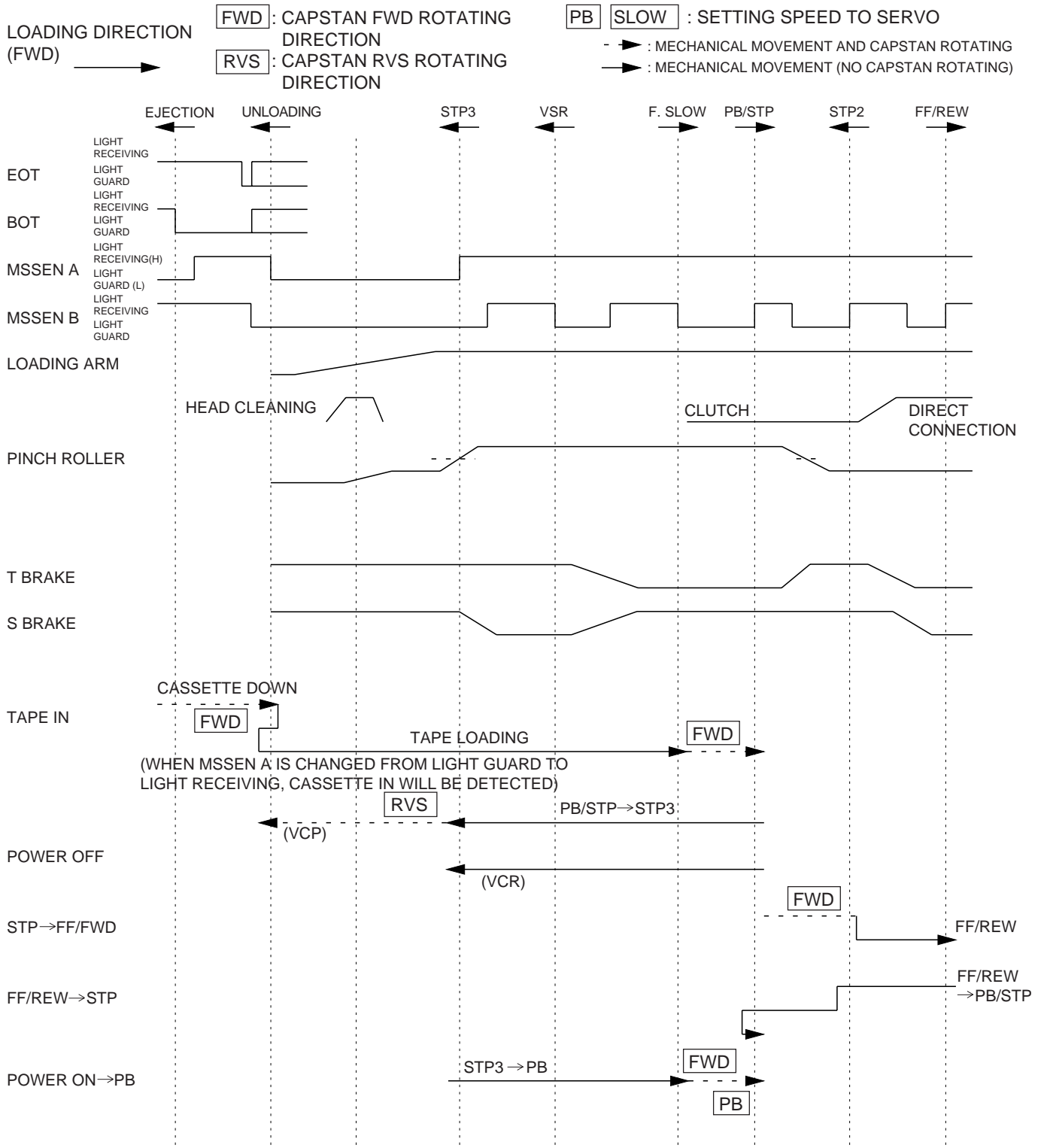

SEMICONDUCTOR BASE CONNECTIONS

DIODE



11DF2N-TA2B2
1SS133T-77
GMA-02-BT
MTZJ12B T-77
MTZJ15B T-77
MTZJ27B T-77
MTZJ33B T-77
MTZJ4.7B T-77

11EQS04N-TA1B2
11ES1N-TA1B2
1N4005E-G23
RD12FB-T7
SB340L-6737

RGP15D-G23

1SS244T-77

MA367-(TX)

SID1050CM

SLZ-345B-02-T1

IC

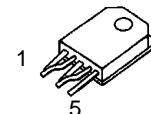
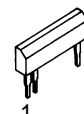
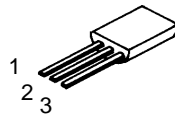
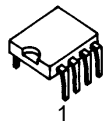
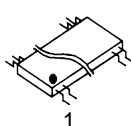
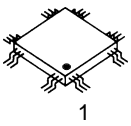

44PIN

BU2979K
TDA9605H
TDA9874H

100PIN

HA118217F
OEC7035A

30PIN

LC74775M

36PIN

LA7158M

8PIN

M24C08-BN6

3PIN

NJM431L
RE5VS31A

8PIN

BA6955AN

5PIN

STR-F6552

TRANSISTOR

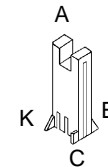
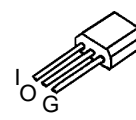
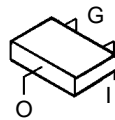
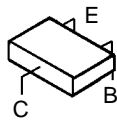
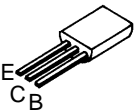

2SB926(S,T)-AA
2SC2274K(E,F)-AA
2SD734(E,F)-AA

2SA1037AKT146R,S
2SC2412KT146 R,S

GP1S94L

DTA124EKAT146
DTC114EKAT146
DTC124EKAT146
DTC143EKAT146
DTC144EKAT146

DTA143ESTP

GP1S566

Y/C/AUDIO/HEAD AMP BLOCK DIAGRAM

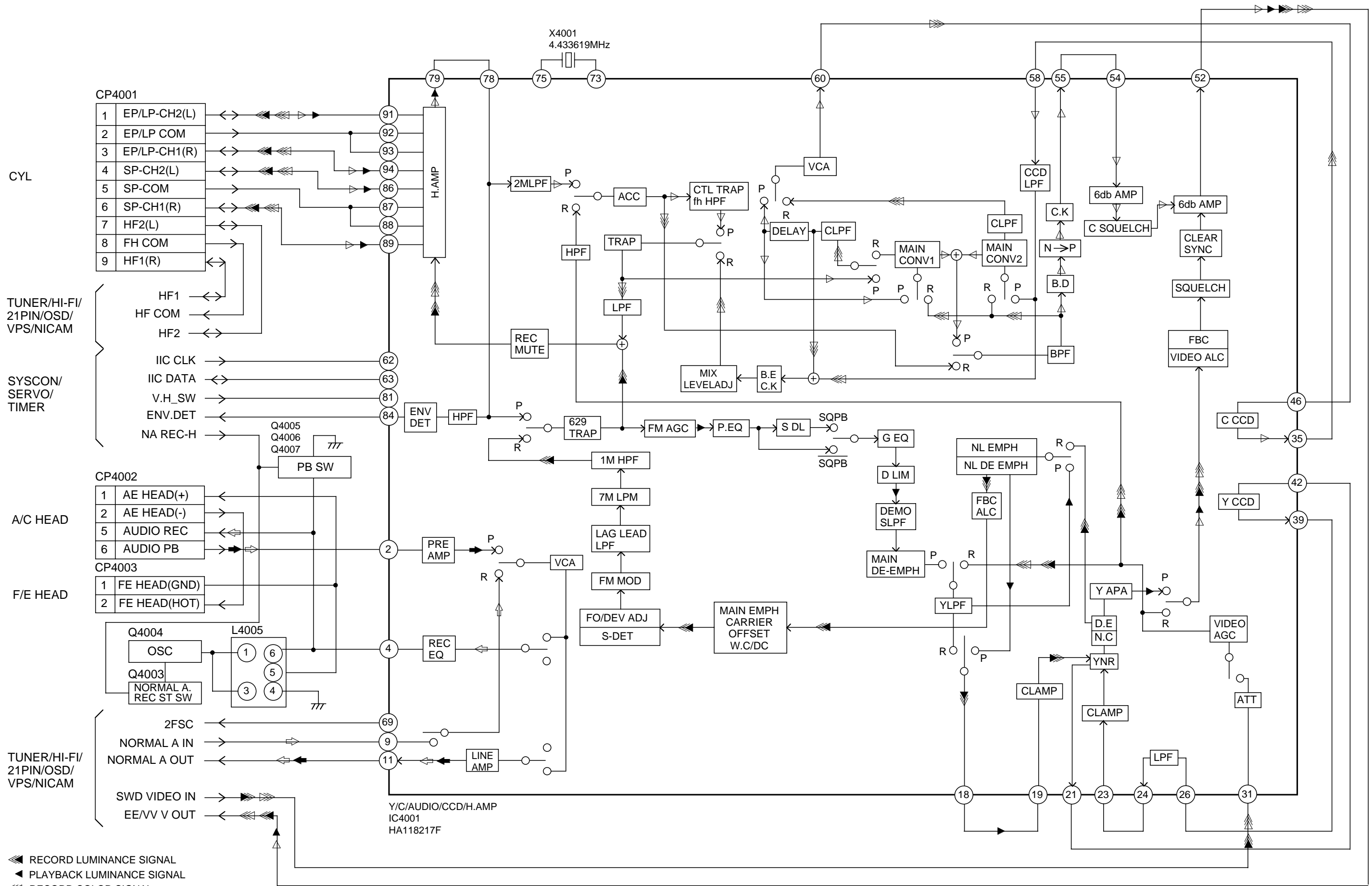

SYSTEM CONTROL/SERVO/TIMER BLOCK DIAGRAM

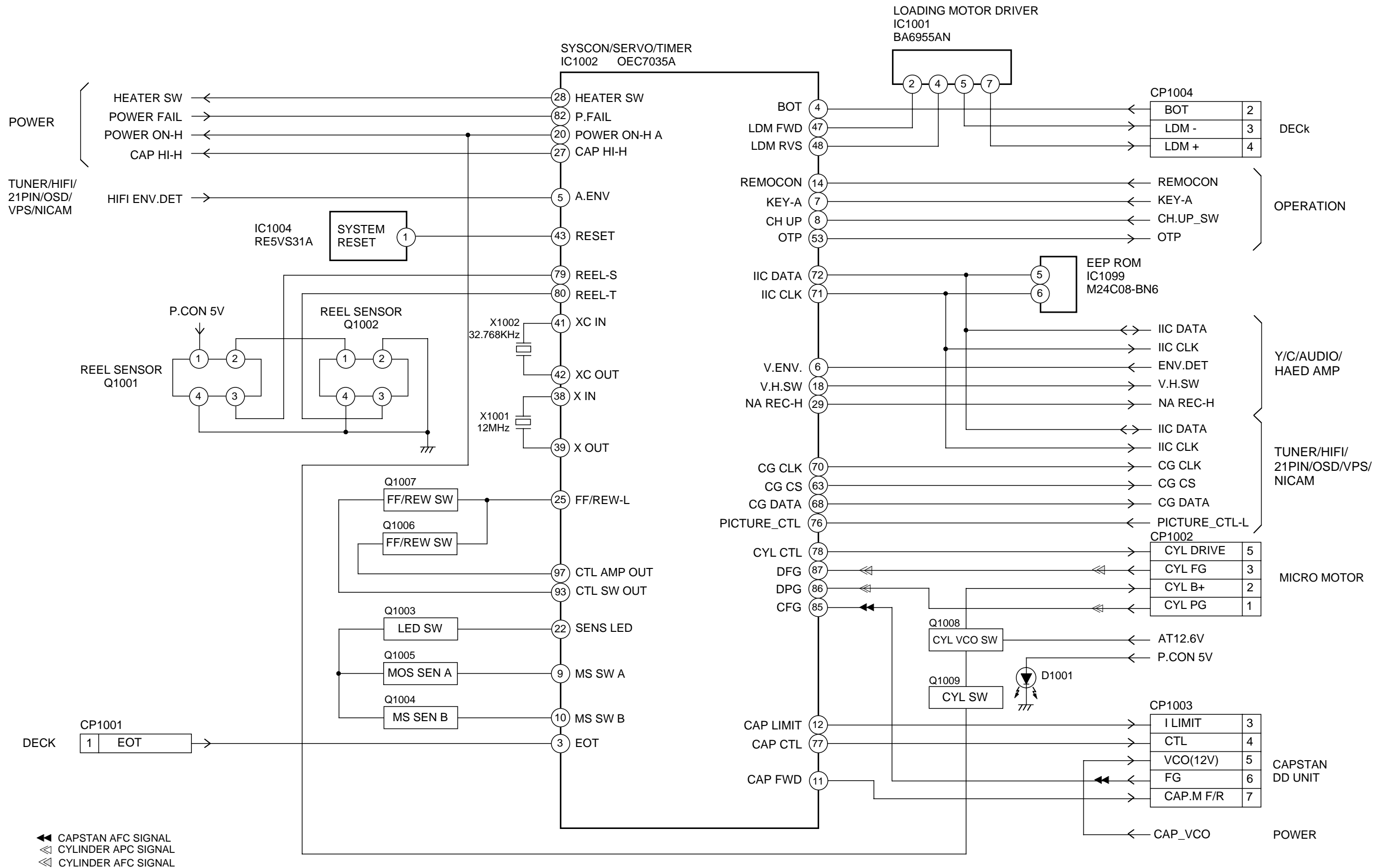

TUNER/HIFI/21PIN/OSD/VPS/NICAM BLOCK DIAGRAM

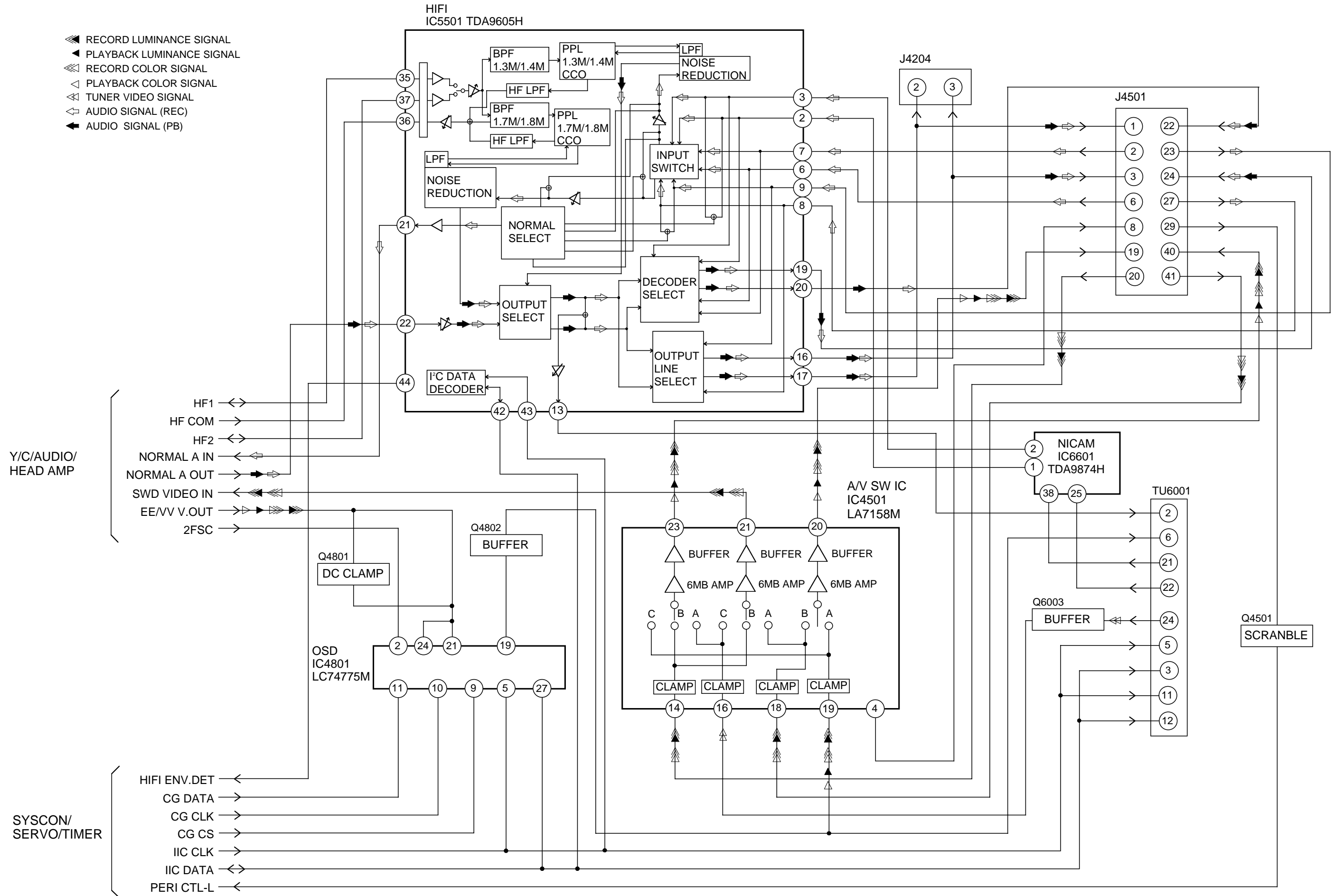

OPERATION BLOCK DIAGRAM

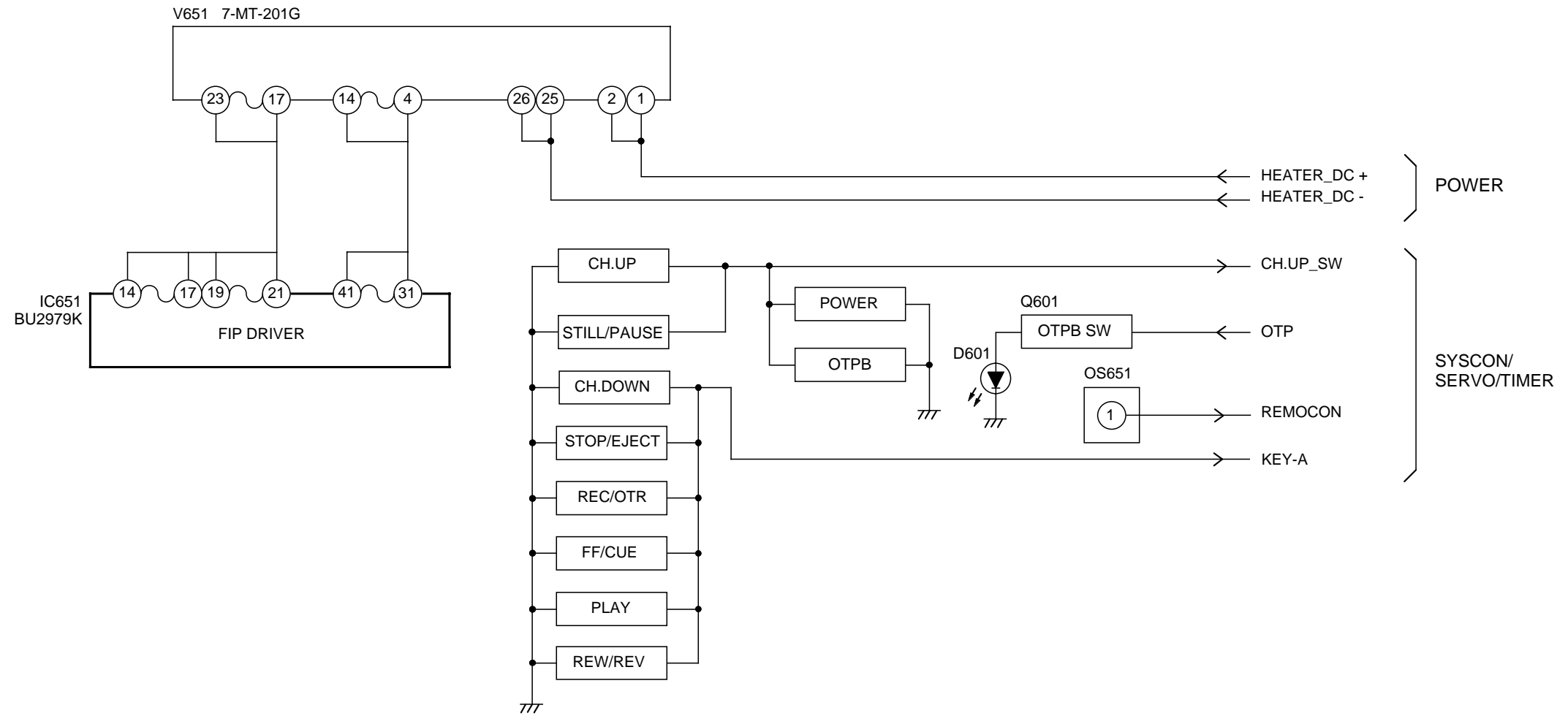

POWER BLOCK DIAGRAM

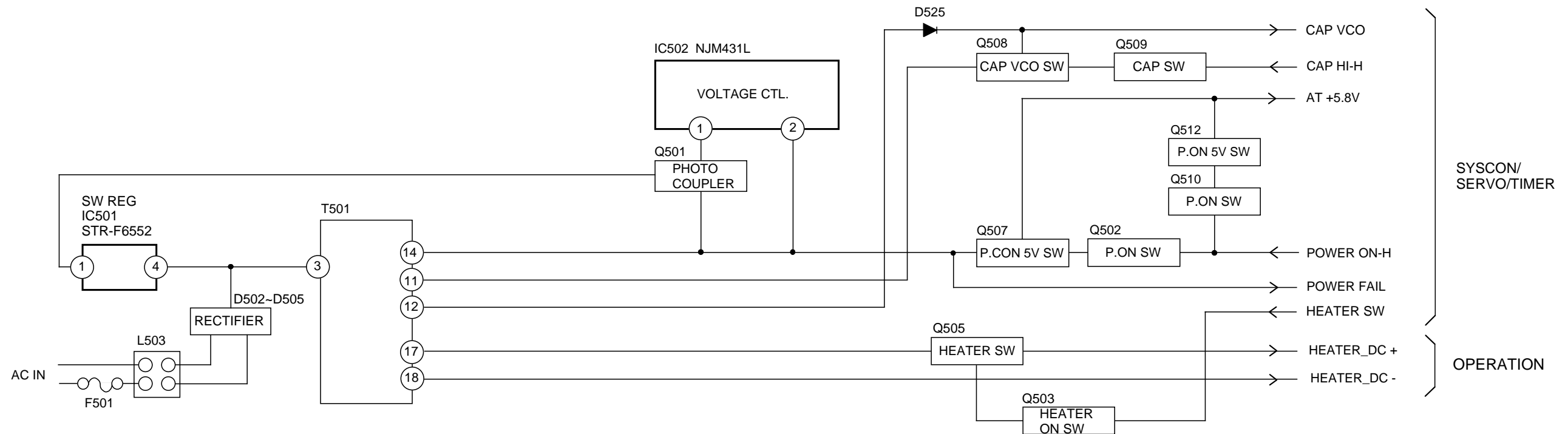

DECK SCHEMATIC DIAGRAM

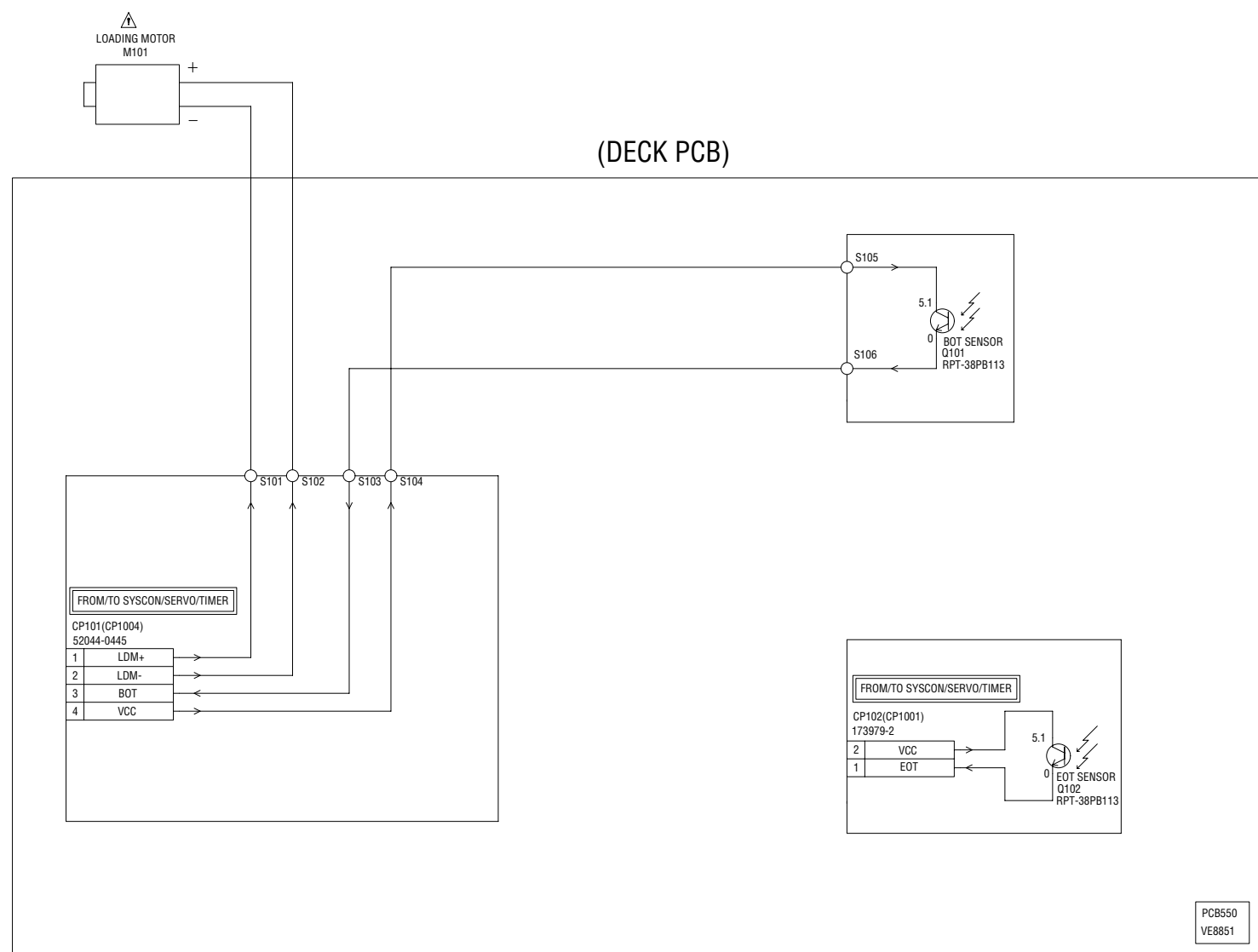

CAUTION: SINCE THESE PARTS MARKED BY  ARE CRITICAL FOR SAFETY, USE ONES DESCRIBED IN PARTS LIST ONLY.

NOTE: THE DC VOLTAGE AT EACH PART WAS MEASURED WITH THE DIGITAL TESTER DURING PLAYBACK.

NOTE: THIS SCHEMATIC DIAGRAM IS THE LATEST AT THE TIME OF PRINTING AND SUBJECT TO CHANGE WITHOUT NOTICE.

OPERATION SCHEMATIC DIAGRAM

(OPERATION 1 PCB)

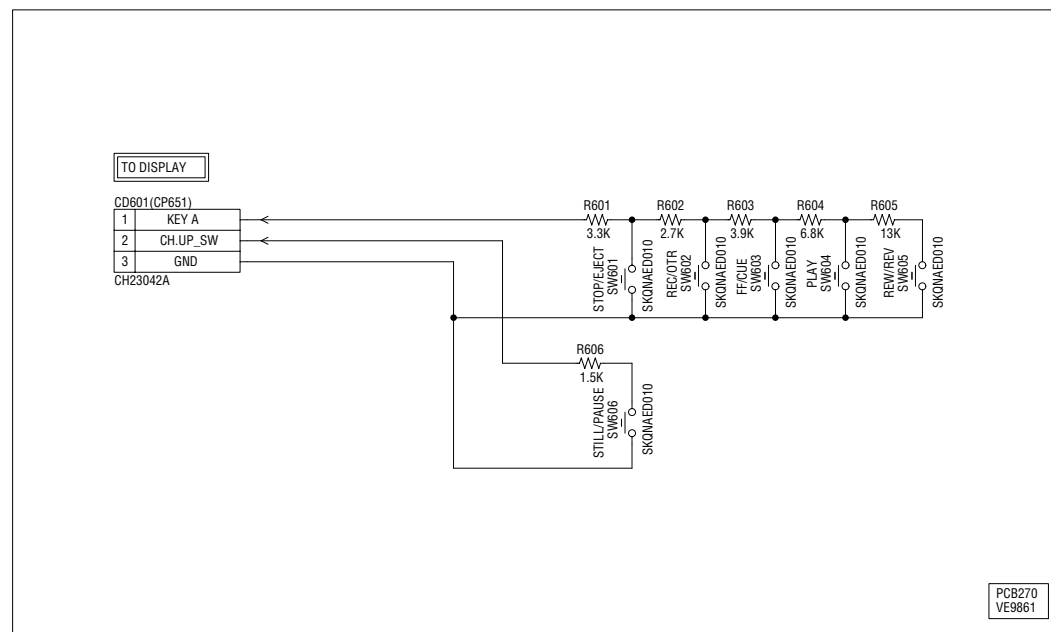

PCB270
VE9861

(OPERATION 2 PCB)

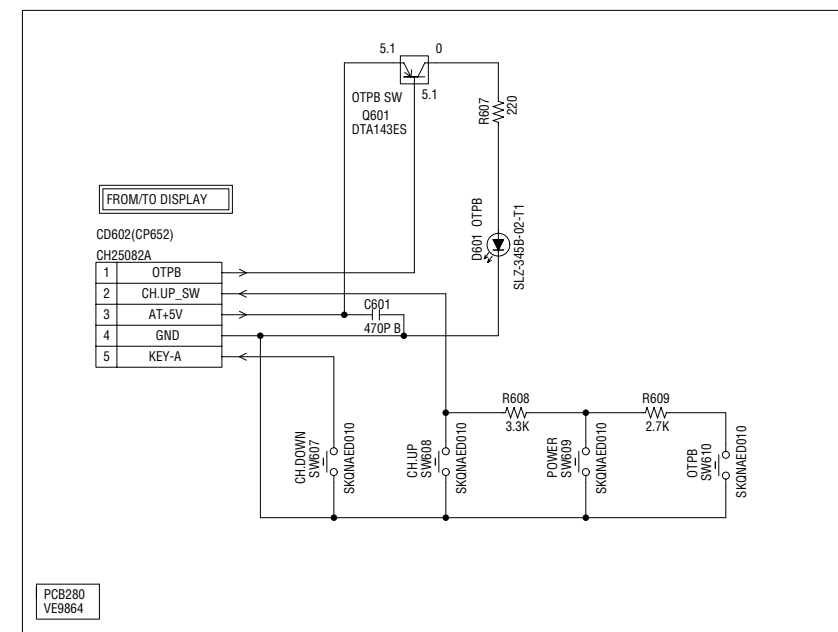

PCB280
VE9864

CAUTION: DIGITAL TRANSISTOR

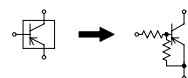

CAUTION: DIGITAL TRANSISTOR

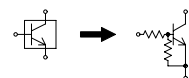

NOTE: THE DC VOLTAGE AT EACH PART WAS MEASURED WITH THE DIGITAL TESTER DURING PLAYBACK.

NOTE: THIS SCHEMATIC DIAGRAM IS THE LATEST AT THE TIME OF PRINTING AND SUBJECT TO CHANGE WITHOUT NOTICE.

PRINTED CIRCUIT BOARDS

OPERATION 1

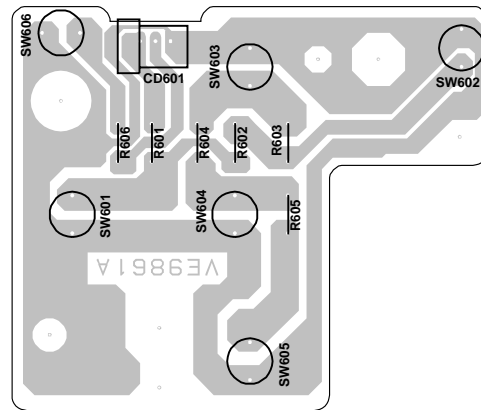

OPERATION 2

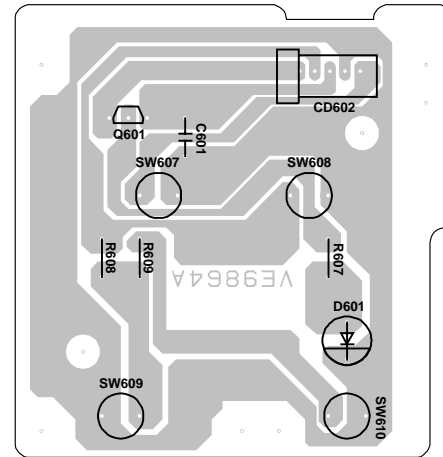

DECK

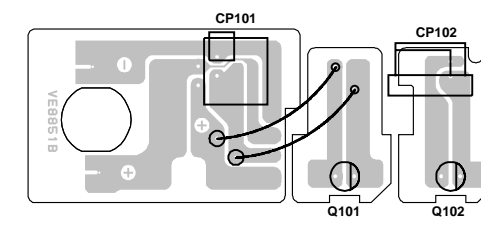

PRINTED CIRCUIT BOARDS
SYSCON

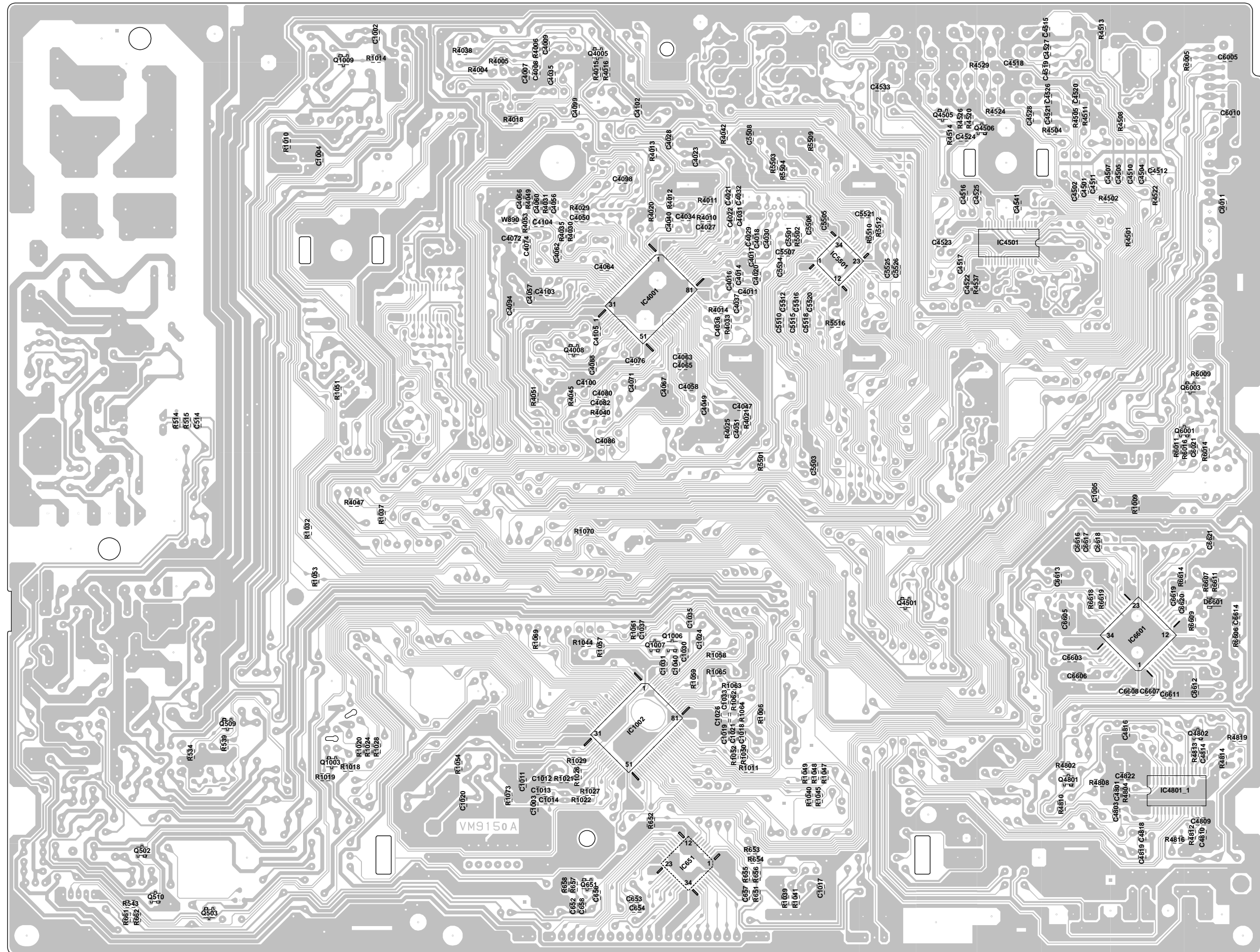

PRINTED CIRCUIT BOARDS SYSCON

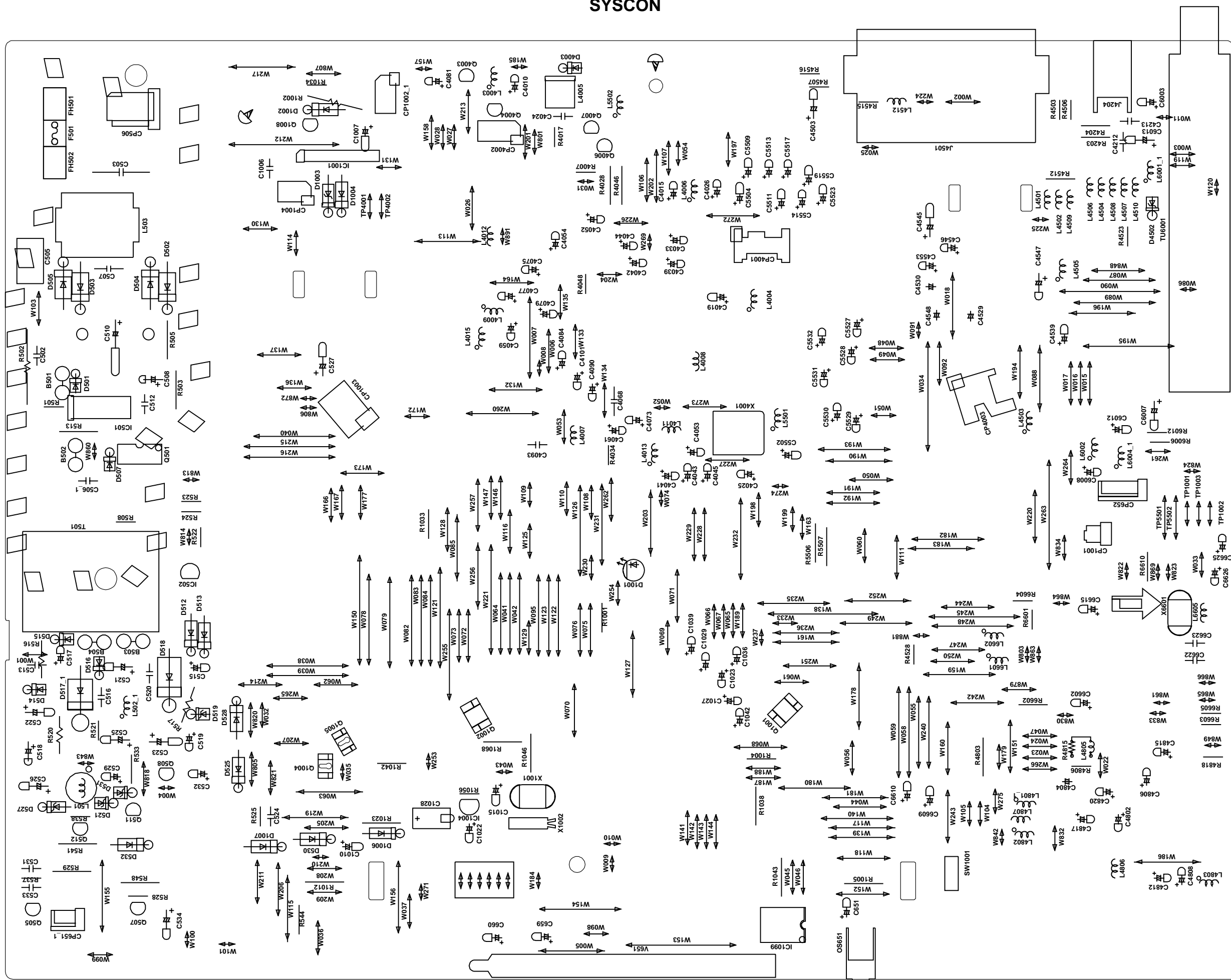

PRINTED CIRCUIT BOARDS
SYSCON

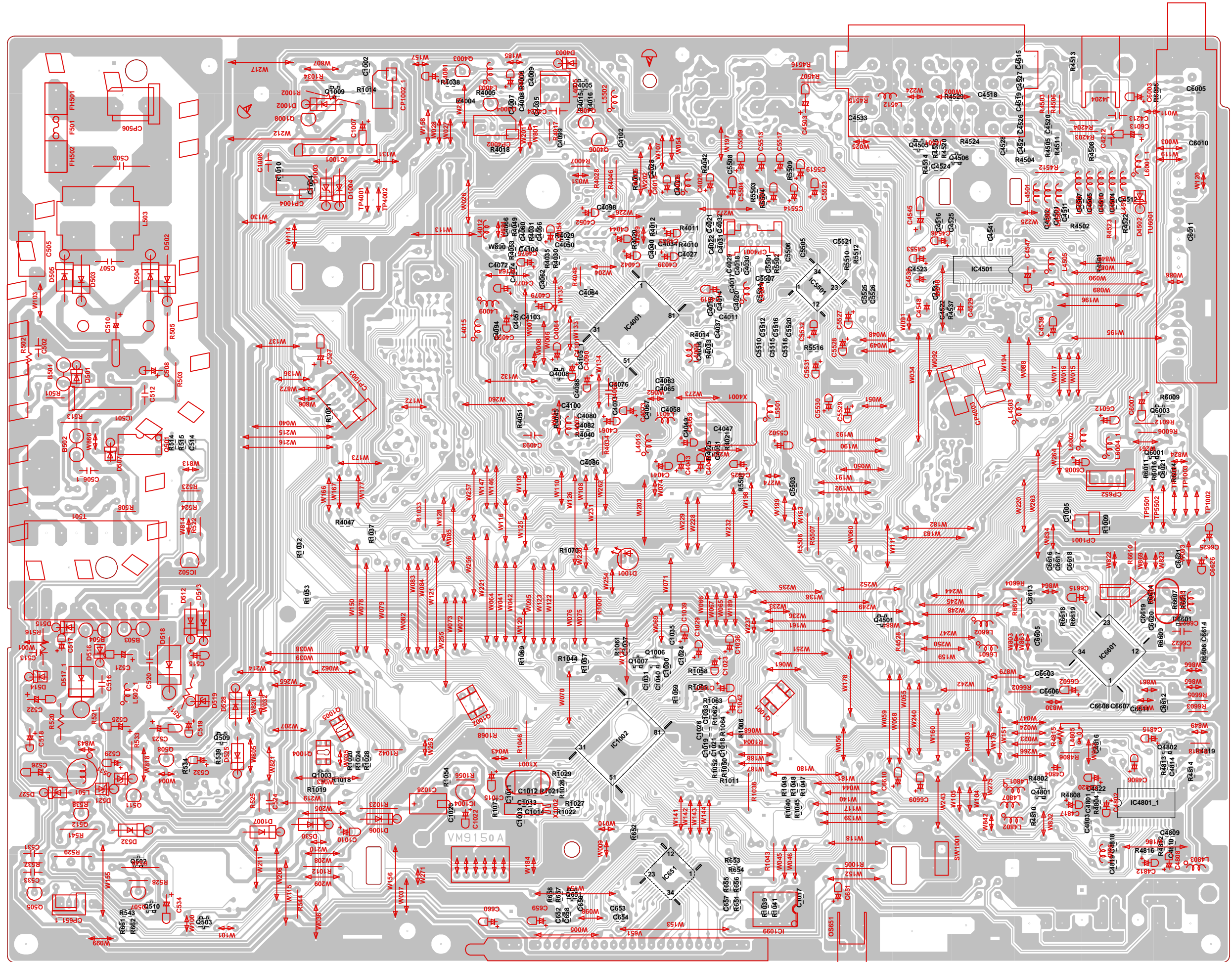

Y/C/AUDIO/HEAD AMP SCHEMATIC DIAGRAM (SYSCON PCB)

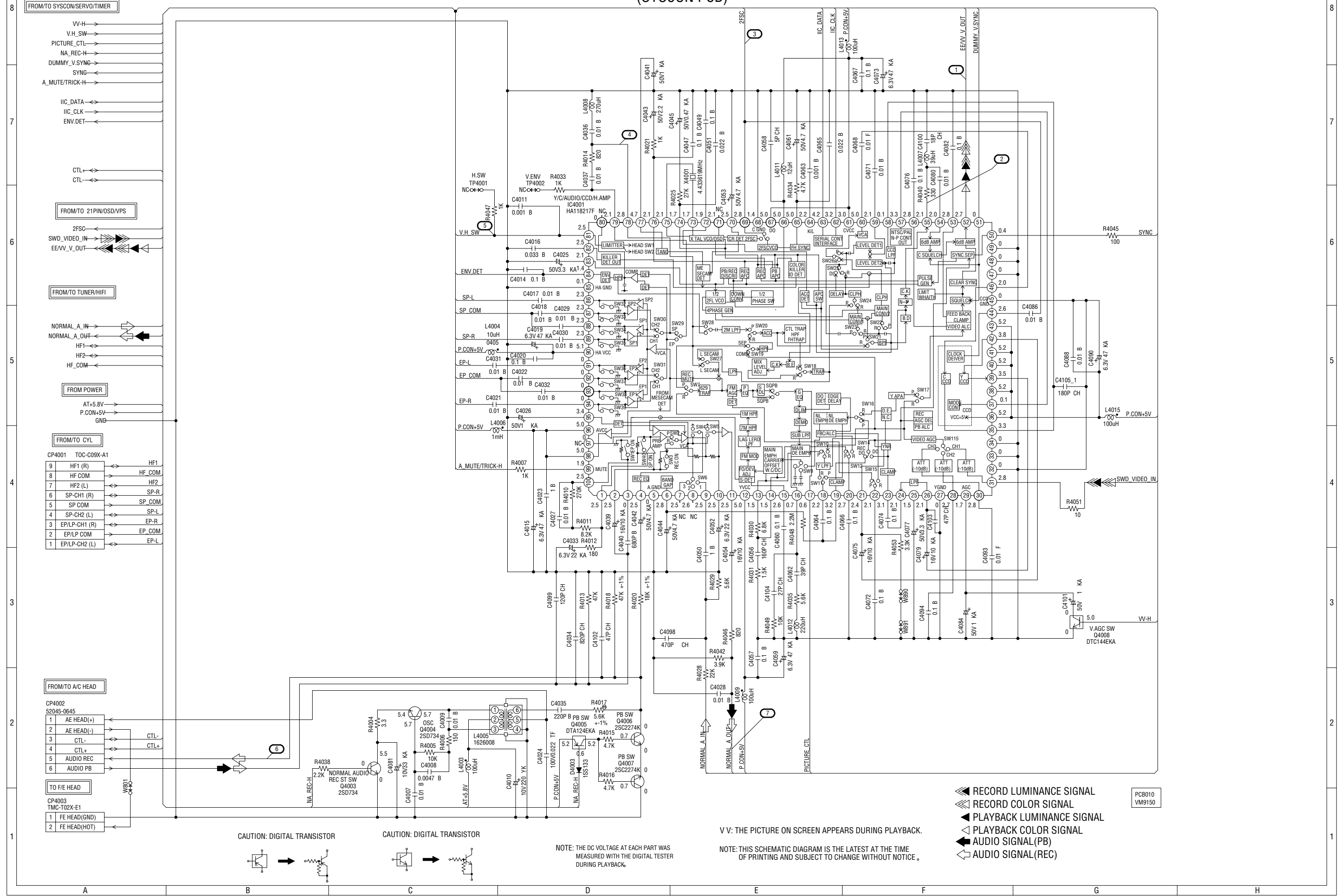

- ◀ RECORD LUMINANCE SIGNAL
- ◀ RECORD COLOR SIGNAL
- ▶ PLAYBACK LUMINANCE SIGNAL
- ▶ PLAYBACK COLOR SIGNAL
- ▶ AUDIO SIGNAL (PB)
- ◀ AUDIO SIGNAL (REC)

V V: THE PICTURE ON SCREEN APPEARS DURING PLAYBACK.
NOTE: THIS SCHEMATIC DIAGRAM IS THE LATEST AT THE TIME OF PRINTING AND SUBJECT TO CHANGE WITHOUT NOTICE.

CAUTION: DIGITAL TRANSISTOR

NOTE: THE DC VOLTAGE AT EACH PART WAS MEASURED WITH THE DIGITAL TESTER DURING PLAYBACK

PCB010
VM9150

SYSTEM CONTROL/SERVO/TIMER SCHEMATIC DIAGRAM

(SYSCON PCB)

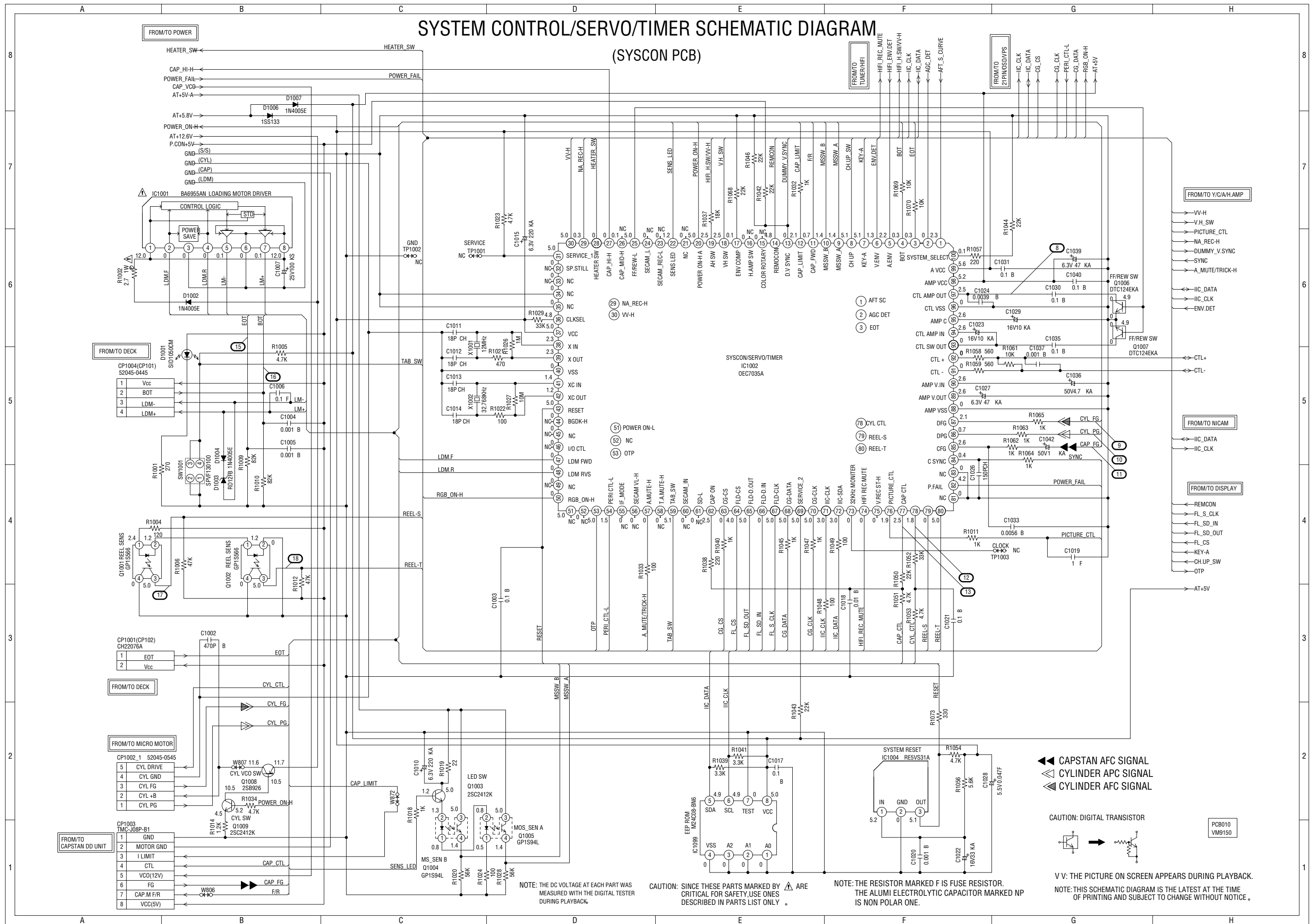

21PIN/OSD/VPS SCHEMATIC DIAGRAM (SYSCON PCB)

- ▶ TUNER VIDEO SIGNAL
 - ▶ RECORD LUMINANCE SIGNAL
 - ▶ RECORD COLOR SIGNAL
 - ▶ PLAYBACK LUMINANCE SIGNAL
 - ▶ PLAYBACK COLOR SIGNAL
 - ▶ AUDIO SIGNAL (REC)
 - ▶ AUDIO SIGNAL (PB)
- CAUTION: DIGITAL TRANSISTOR
-

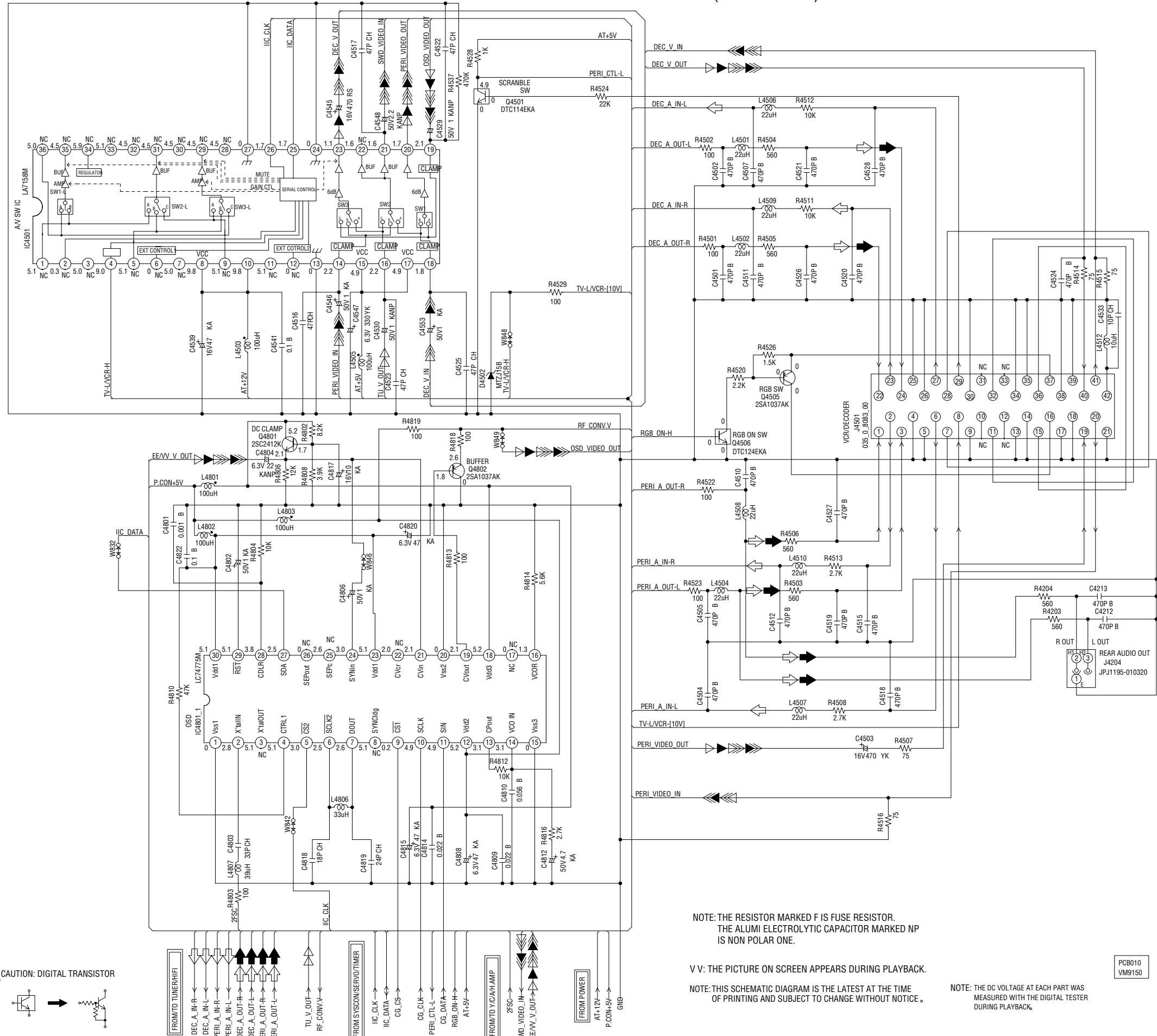

NOTE: THE RESISTOR MARKED F IS FUSE RESISTOR.
THE ALUMI ELECTROLYTIC CAPACITOR MARKED NP IS NON POLAR ONE.

V V: THE PICTURE ON SCREEN APPEARS DURING PLAYBACK.

NOTE: THIS SCHEMATIC DIAGRAM IS THE LATEST AT THE TIME OF PRINTING AND SUBJECT TO CHANGE WITHOUT NOTICE.

NOTE: THE DC VOLTAGE AT EACH PART WAS MEASURED WITH THE DIGITAL TESTER DURING PLAYBACK.

PCB010
VM9150

TUNER/HIFI SCHEMATIC DIAGRAM (SYSCON PCB)

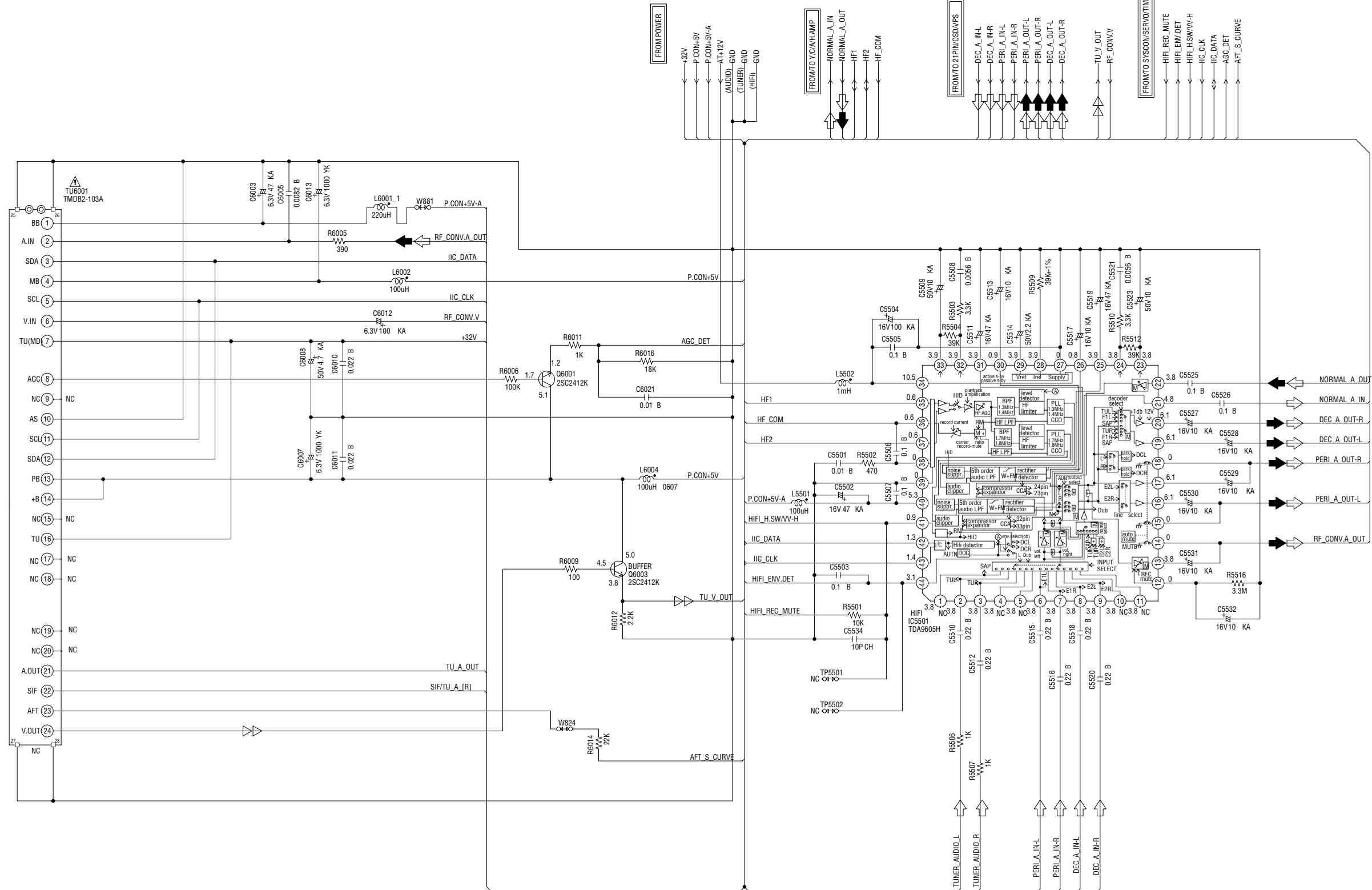

NOTE: THE DC VOLTAGE AT EACH PART WAS MEASURED WITH THE DIGITAL TESTER DURING PLAYBACK.

NOTE: THIS SCHEMATIC DIAGRAM IS THE LATEST AT THE TIME OF PRINTING AND SUBJECT TO CHANGE WITHOUT NOTICE.

CAUTION: SINCE THESE PARTS MARKED BY ARE CRITICAL FOR SAFETY, USE ONES DESCRIBED IN PARTS LIST ONLY.

TUNER VIDEO SIGNAL
 AUDIO SIGNAL (PB)
 AUDIO SIGNAL (REC)

PCB010
VM9150

POWER SCHEMATIC DIAGRAM (SYSCON PCB)

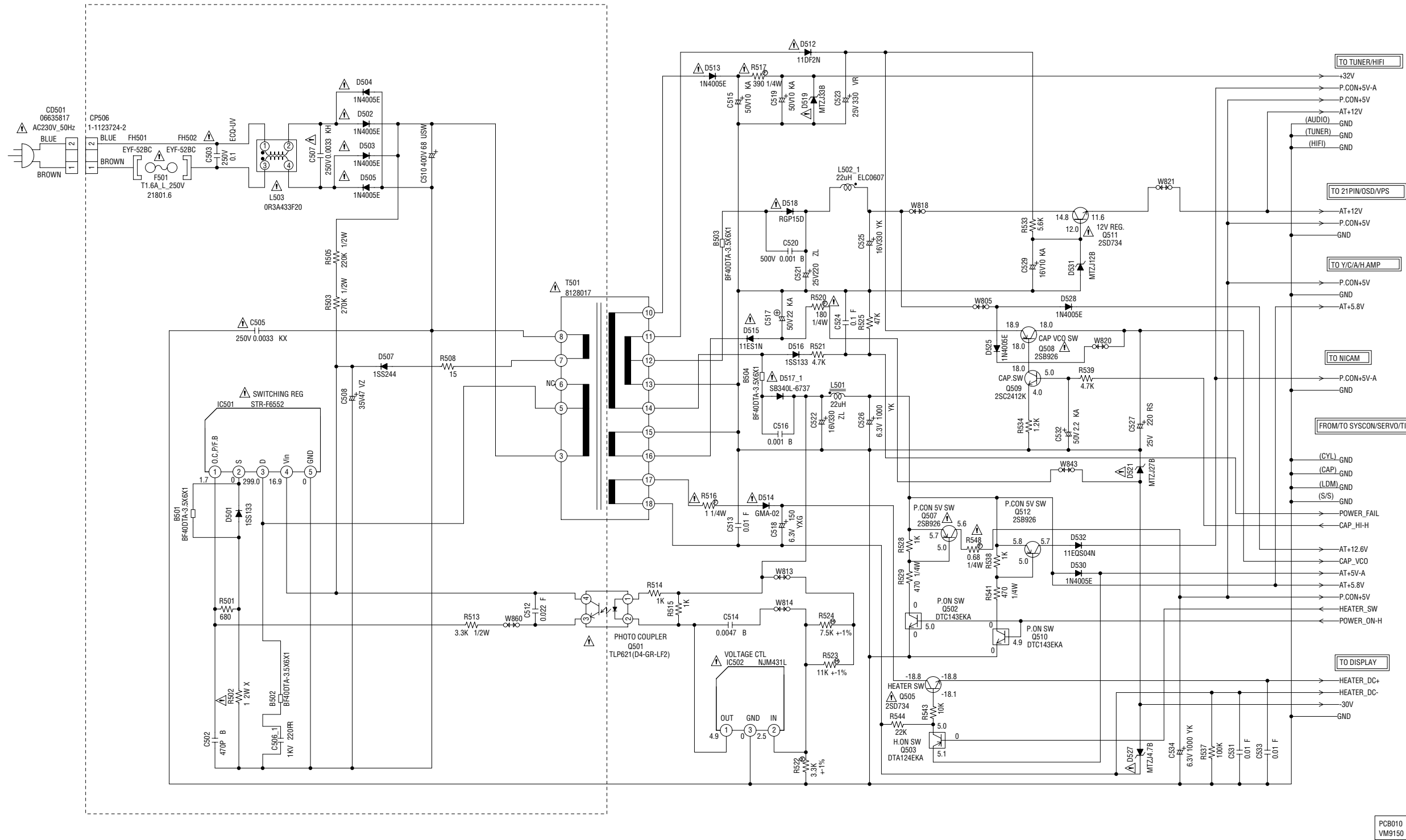

CAUTION: SINCE THESE PARTS MARKED BY ARE CRITICAL FOR SAFETY, USE ONES DESCRIBED IN PARTS LIST ONLY.

NOTE: THE RESISTOR MARKED F IS FUSE RESISTOR. THE ALUMI ELECTROLYTIC CAPACITOR MARKED NP IS NON POLAR ONE.

NOTE: THE DC VOLTAGE AT EACH PART WAS MEASURED WITH THE DIGITAL TESTER DURING PLAYBACK.

NOTE: THIS SCHEMATIC DIAGRAM IS THE LATEST AT THE TIME OF PRINTING AND SUBJECT TO CHANGE WITHOUT NOTICE.

CAUTION: DIGITAL TRANSISTOR

CAUTION: DIGITAL TRANSISTOR

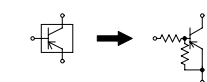
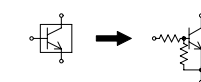

DISPLAY SCHEMATIC DIAGRAM (SYSCON PCB)

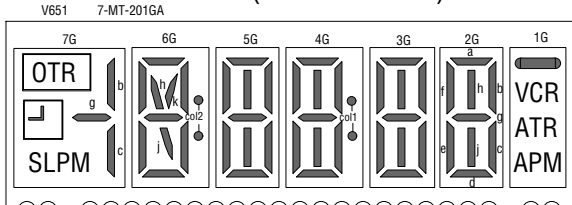

V651 (7-MT-201GA) ANODE CONNECTION

	7G	6G	5G	4G	3G	2G	1G
P1	S	h	h	h	h	h	M
P2	L	k	—	—	—	—	P
P3	M	col2	—	col1	—	—	A
P4	☐	f	f	f	f	f	ATR
P5	b	b	b	b	b	b	VCR
P6	OTR	a	a	a	a	a	—
P7	g	g	g	g	g	g	—
P8	—	e	e	e	e	e	—
P9	P	j	j	j	j	j	—
P10	c	c	c	c	c	c	—
P11	—	d	d	d	d	d	—

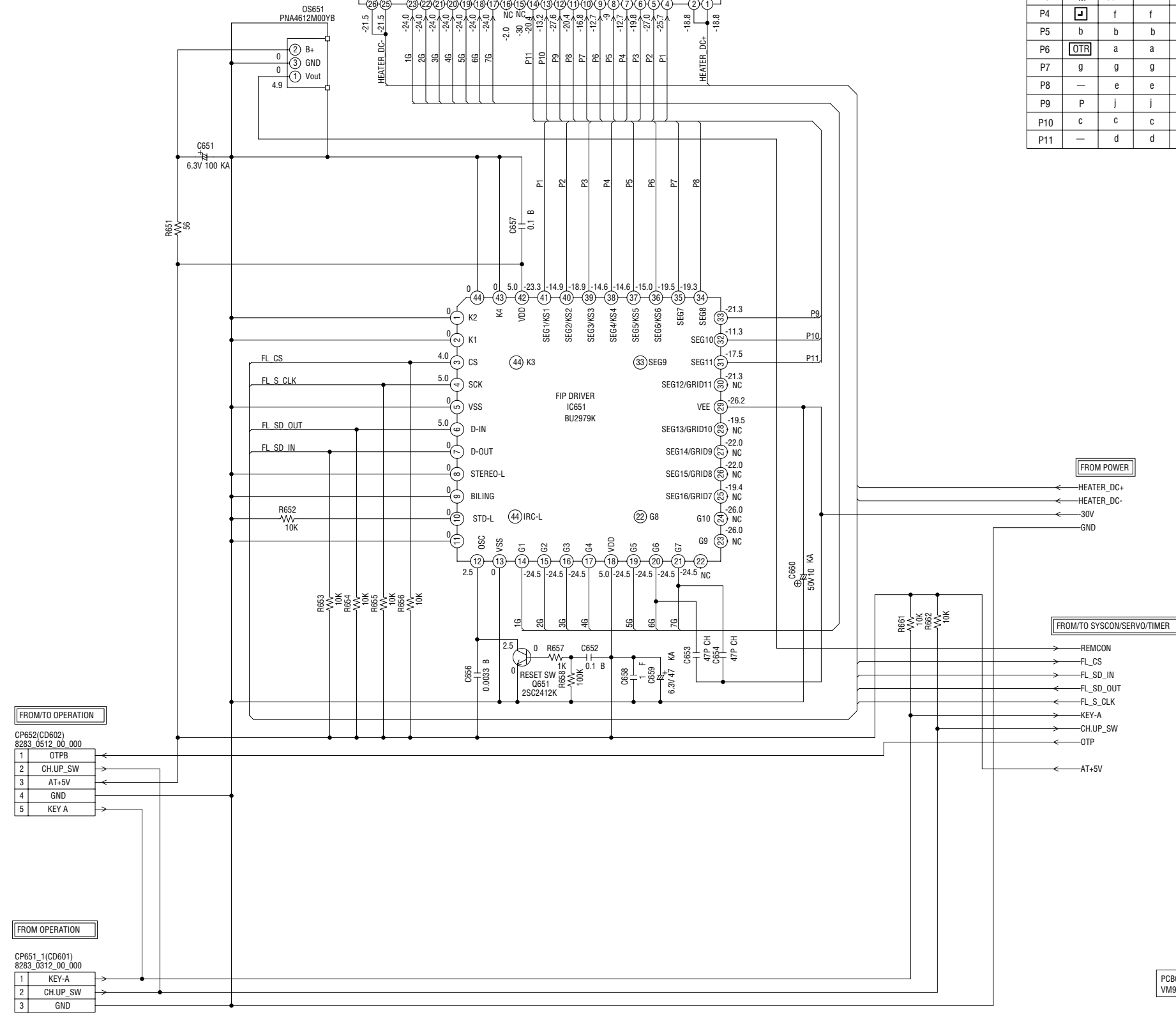

NOTE: THE DC VOLTAGE AT EACH PART WAS MEASURED WITH THE DIGITAL TESTER DURING PLAYBACK.

NOTE: THIS SCHEMATIC DIAGRAM IS THE LATEST AT THE TIME OF PRINTING AND SUBJECT TO CHANGE WITHOUT NOTICE.

NICAM SCHEMATIC DIAGRAM

(SYSCON PCB)

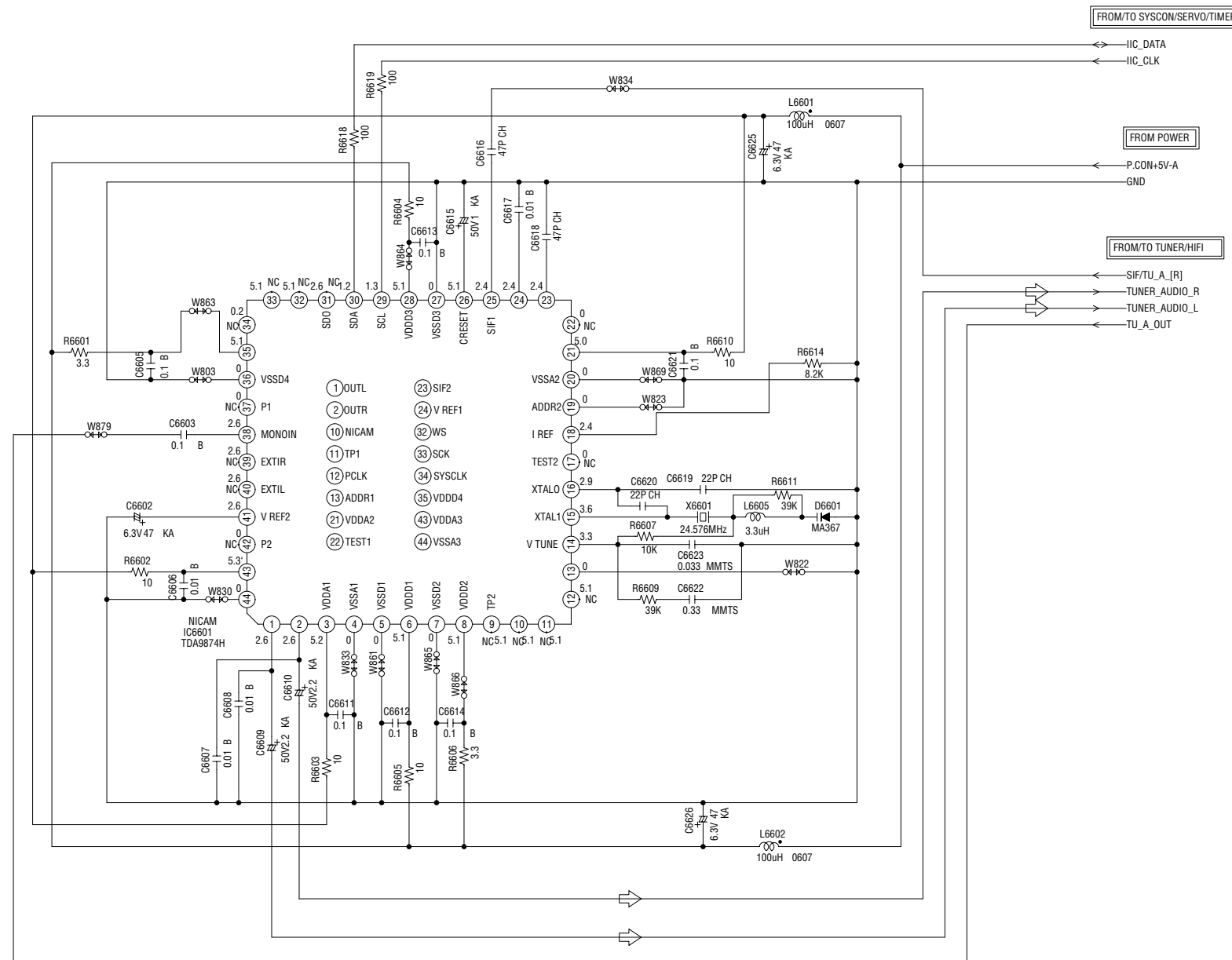

NOTE: THE DC VOLTAGE AT EACH PART WAS MEASURED WITH THE DIGITAL TESTER DURING PLAYBACK.

NOTE: THIS SCHEMATIC DIAGRAM IS THE LATEST AT THE TIME OF PRINTING AND SUBJECT TO CHANGE WITHOUT NOTICE.

← AUDIO SIGNAL(REC)

PCB010
VM9150

INTERCONNECTION DIAGRAM

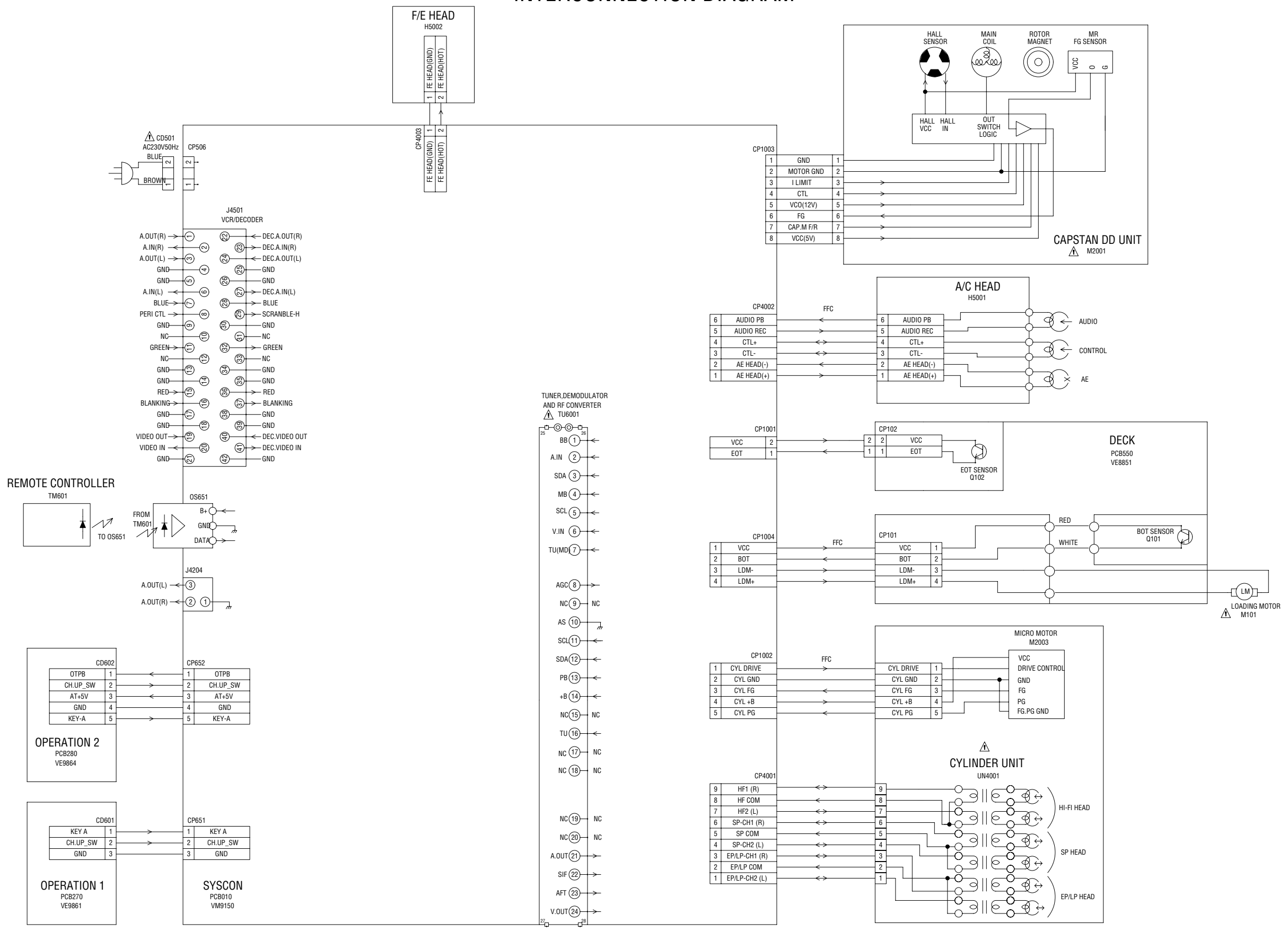

CAUTION: SINCE THESE PARTS MARKED BY ARE CRITICAL FOR SAFETY, USE ONES DESCRIBED IN PARTS LIST ONLY.

NOTE: THIS INTERCONNECTION DIAGRAM IS THE LATEST AT THE TIME OF PRINTING AND SUBJECT TO CHANGE WITHOUT NOTICE.

WAVEFORMS

Y/C/AUDIO/HEAD AMP

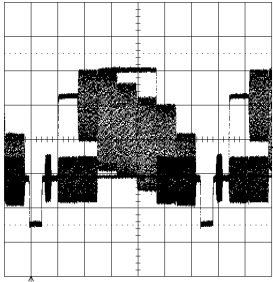

① REC
0.5V 10 μ s/div

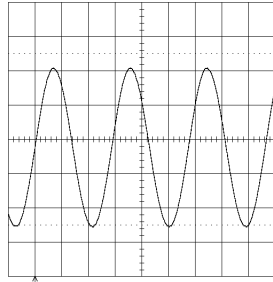

⑥ REC
10V 5 μ s/div

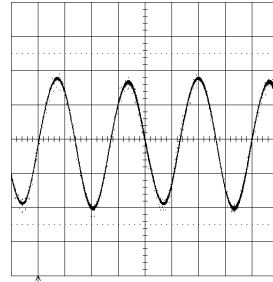

⑪ REC, PB
0.5V 0.5ms/div

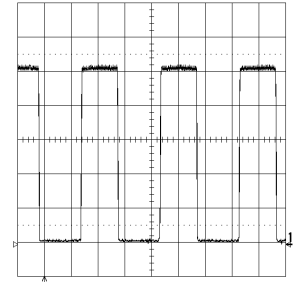

⑰ REC, PB
1V 0.5s/div

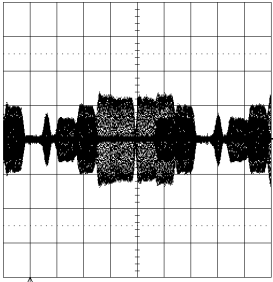

② PB
200mV 10 μ s/div

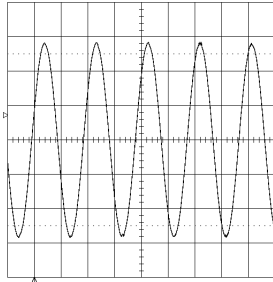

⑦ REC, PB
200mV 0.5ms/div

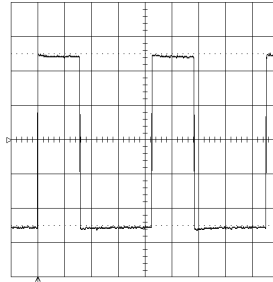

⑫ REC, PB
1V 5 μ s/div

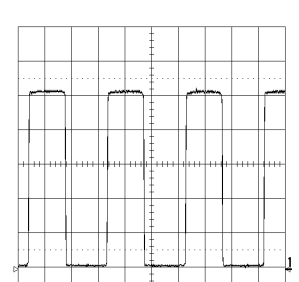

⑱ REC, PB
1V 0.5s/div

SYSCON/SERVO/TIMER

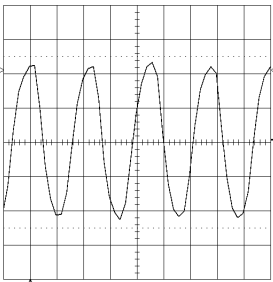

③ POWER ON
100mV 50ns/div

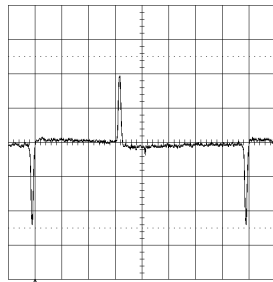

⑧ REC, PB
1V 5ms/div

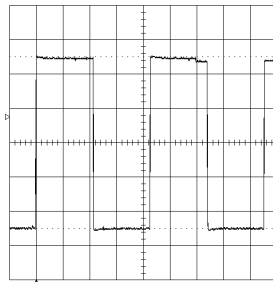

⑬ REC, PB
1V 5 μ s/div

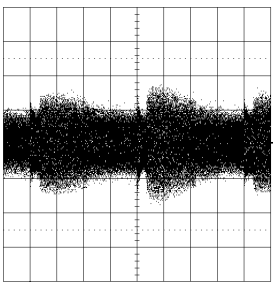

④ PB
100mV 5ms/div

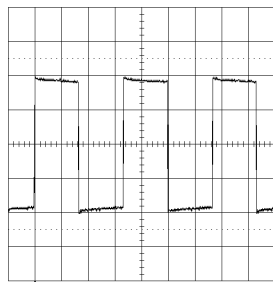

⑨ REC, PB
1V 0.5ms/div

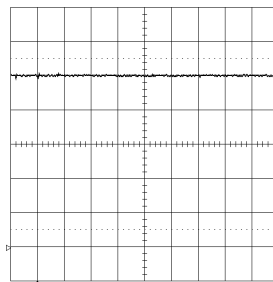

⑮ CASS. LESS
1V 10 μ s/div

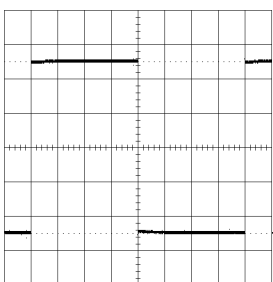

⑤ REC, PB
1V 5ms/div

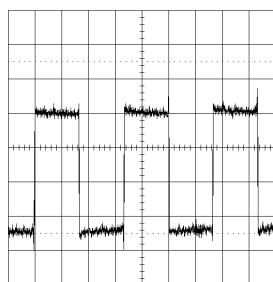

⑩ REC, PB
200mV 0.5ms/div

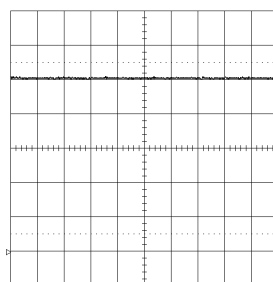

⑯ CASS. LESS
1V 10 μ s/div

NOTE: The following waveforms were measured at the point of the corresponding balloon number in the schematic diagram.

MECHANICAL EXPLODED VIEW

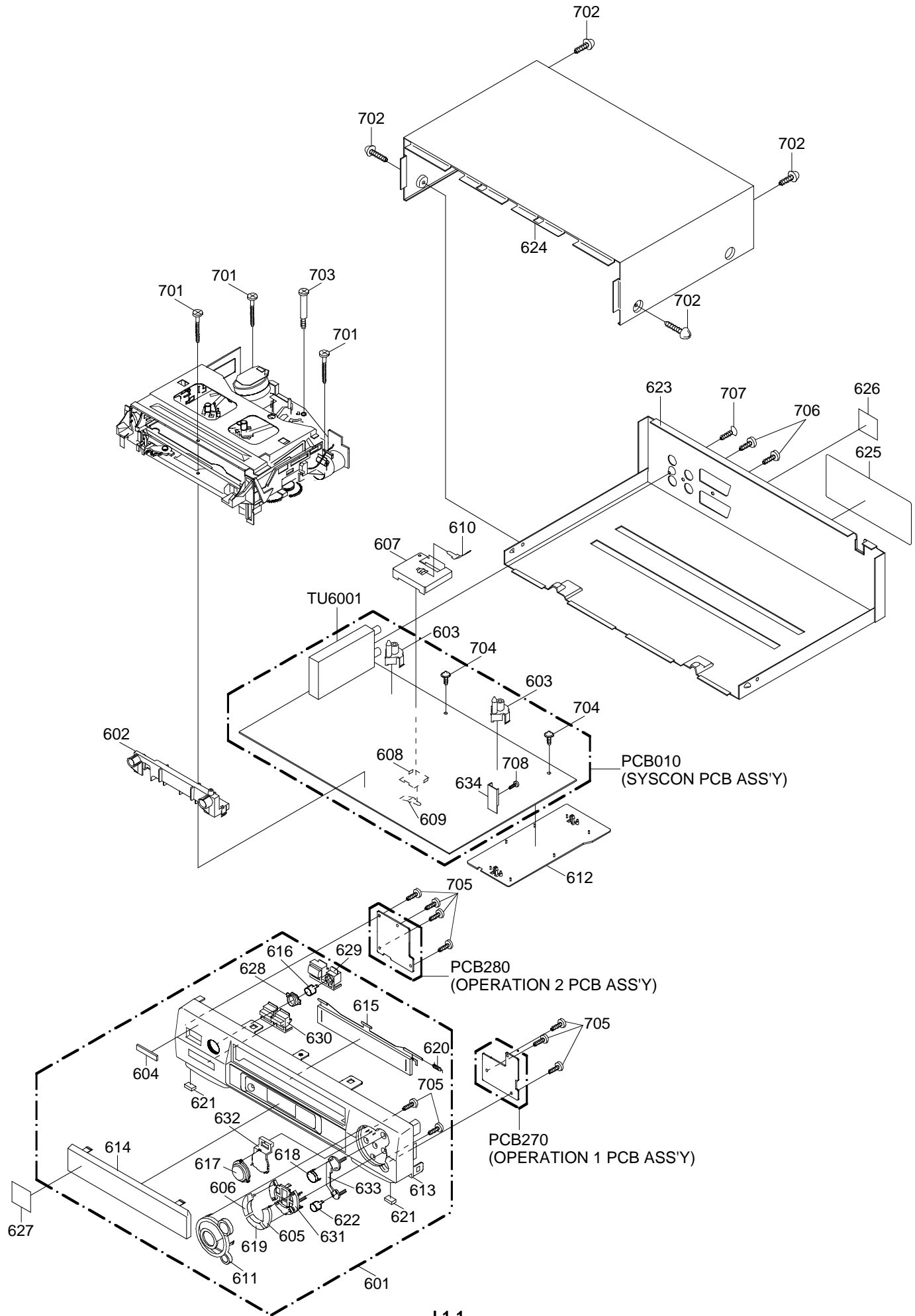

MECHANICAL REPLACEMENT PARTS LIST

REF. NO.	PART NO.	DESCRIPTION	Q'TY
601	S4-D40-4B7-200	CAB,FRONT ASS'Y	1
602	S0-1WP-A03-480	HOLDER,DECK(A)	1
603	S0-4WP-A00-070	HOLDER,DECK(R)	2
604	S2-344-900-130	BADGE,BRAND	1
605	S3-5WP-D06-050	BUTTON,FF	1
606	S3-5WP-D06-060	BUTTON,REW	1
607	-----	SHIELD,CASE HEAD AMP	1
608	-----	SHIELD,COVER HEAD AMP	1
609	-----	SPR,EARTH HEAD AMP	1
610	-----	SPR,EARTH HEAD AMP	1
611	S3-5WP-D06-070	BUTTON,BASE	1
612	S5-5WP-A00-090	PLATE,COVER POWER	1
613	-----	CAB,FRONT	1
614	S1-1WP-D05-370	PLATE,DISPLAY	1
615	S1-2WP-J05-980	FLAP	1
616	S3-5WP-D06-020	BUTTON,OTPB	1
617	S3-5WP-D06-270	BUTTON,PLAY	1
618	S3-5WP-D06-030	BUTTON,REC	1
619	S3-5WP-D06-040	BUTTON,STOP/EJECT	1
620	S4-3WK-A00-320	SPR,FLAP	1
621	S0-0WF-A00-200	CUSHION,LEG	1
622	S3-5WP-D06-080	BUTTON,PAUSE	1
623	-----	PLATE,BOTTOM	1
624	S0-2US-S00-250	CABI,TOP	1
625	-----	SHEET,RATING	1
626	-----	LABEL,ANTI-THEFT	1
627	-----	POP,LABEL	1
628	S3-5WP-D06-090	RING,OTPB	1
629	S3-5WP-D06-250	BUTTON,POWER	1
630	S3-5WP-D06-260	BUTTON,CHANNEL	1
631	S3-8WP-A00-110	HOLDER,BUTTON(1)	1
632	S3-8WP-A00-120	HOLDER,BUTTON(2)	1
633	S3-8WP-A00-130	HOLDER,BUTTON(3)	1
634	-----	HEAT SINK	1
701	S1-071-40B-940	SCREW,TAP(S)PAN 4-29	3
702	S1-072-408-020	SCREW,TAP BIND 4-8	4
703	87-078-174-010	SCREW TAP TITE(S)BIND 4-6	1
704	87-753-095-410	SCREW,TAP(S)BIND 3-7	2
705	87-743-074-010	VT2+2.6-8	9
706	87-741-094-410	SCREW,TAP 3-6 BIND	2
707	S1-072-304-040	UIT+3-4	1
708	S1-0A1-30A-040	SCREW/WASHER(B)M3-10	1

ACCESSORY REPLACEMENT PARTS LIST

REF. NO.	PART NO.	DESCRIPTION	Q'TY
1	S6-CPL-050-170	CABLE,PAL CPL05017	1
2	S6-CNB-A50-050	CORD,RCA PIN 06CNBA5005	1
3	S7-660-BS0-300	TRANSMITTER	1
4	S4-D40-401-000	INSTRUCTION BOOK	1

CHASSIS EXPLODED VIEW (TOP VIEW)

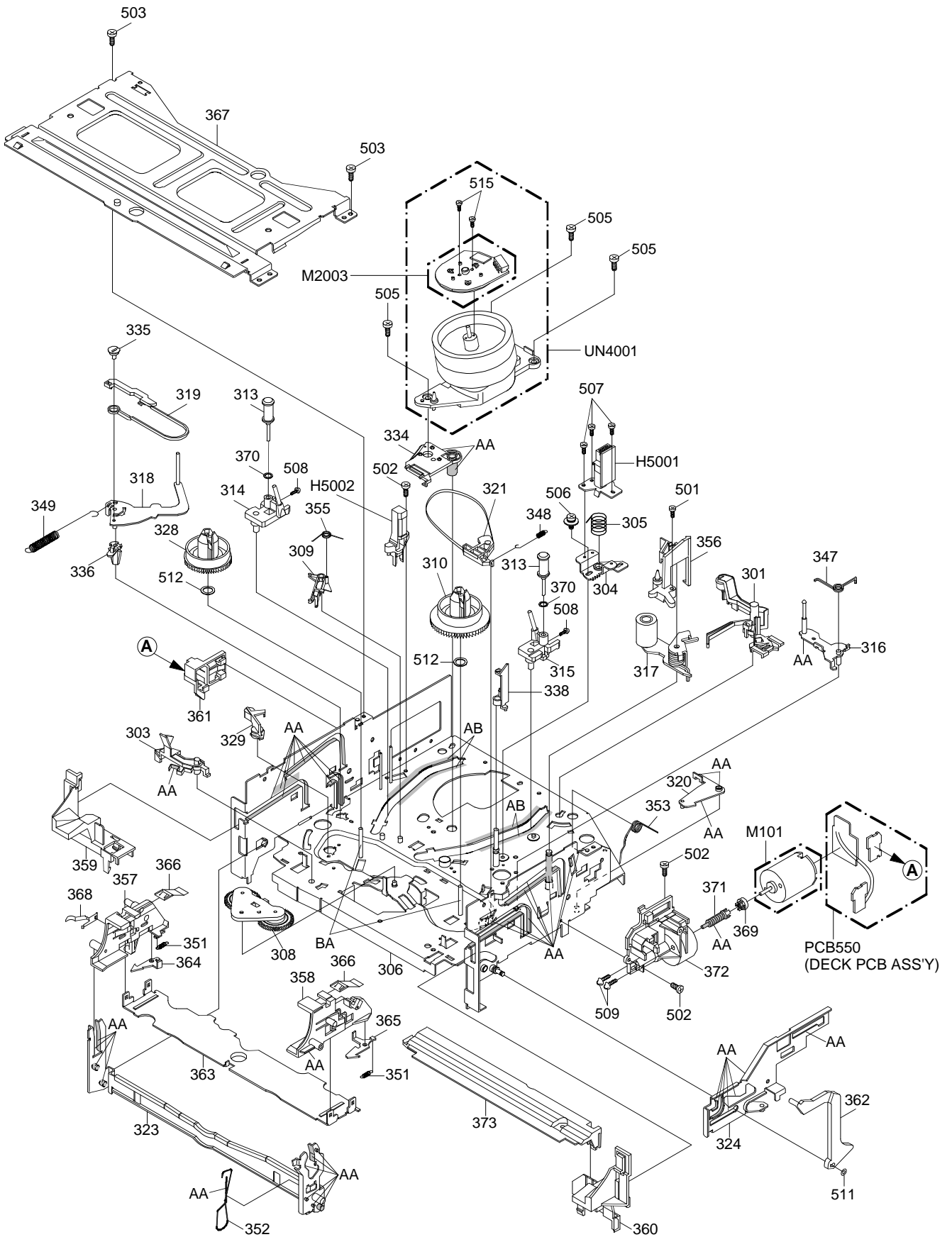

CLASS	PART NO.	MARK
GREASE	G-555G	AA
	G-488M	AB
	FL-721	AC
OIL	KYODO OIL SLIDAS No. 150	BA

NOTE: Applying positions AA, AB, AC and BA for the grease or oil are displayed for this section. Check if the correct grease or oil is applied for each position.

CHASSIS EXPLODED VIEW (BOTTOM VIEW)

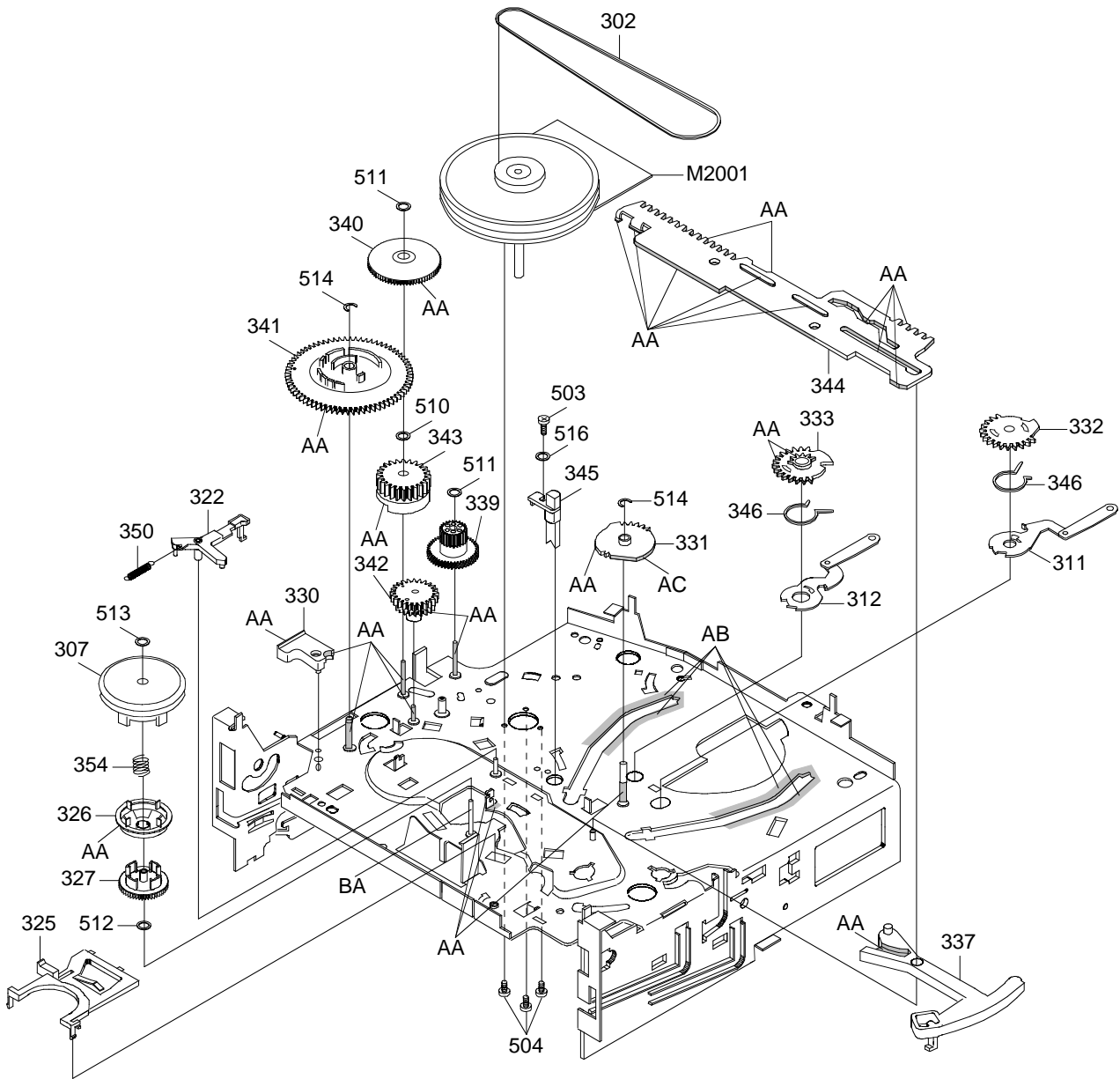

CLASS	PART NO.	MARK
GREASE	G-555G	AA
	G-488M	AB
	FL-721	AC
OIL	KYODO OIL SLIDAS No. 150	BA

NOTE: Applying positions AA, AB, AC and BA for the grease or oil are displayed for this section. Check if the correct grease or oil is applied for each position.

CHASSIS REPLACEMENT PARTS LIST

REF. NO.	PART NO.	DESCRIPTION	Q'TY	REF. NO.	PART NO.	DESCRIPTION	Q'TY
301	S5-OA5-000-220	AHC ASS'Y	1	360	S5-OP9-006-860	TAPE GUIDE R	1
302	S5-OP2-002-700	BELT,CAPSTAN	1	361	S5-OP9-006-870	COVER,SENSOR L	1
303	S5-OP9-006-890	LEVER,REC	1	362	S5-OP9-006-880	LEVER,FLAP	1
304	S5-OP5-000-830	BASE,AC HEAD	1	363	S5-OP9-006-900	CASS HOLDER	1
305	S5-OP8-003-240	SPR,AC HEAD	1	364	S5-OP9-006-910	LOCKER,L	1
306	S5-OA0-002-970	MAIN CHASSIS ASS'Y	1	365	S5-OP9-006-920	LOCKER,R	1
307	S5-OA2-000-810	CLUTCH ASS'Y X	1	366	S5-OP9-006-940	SPR,PACK	2
308	S5-OA2-000-730	ARM,IDLER ASS'Y	1	367	S5-OP9-006-950	BRACKET, TOP	1
309	S5-OP6-005-530	ARM,S-S BRAKE	1	368	-----	SPR,CASS EARTH	1
				369	S5-OP6-005-400	DRIVER,WORM	1
310	S5-OA2-000-760	T REEL ASS'Y	1				
311	S5-OA3-000-610	LOAD ARM S ASS'Y	1	370	S5-OP4-004-850	O-RING	2
312	S5-OA3-000-620	LOAD ARM T ASS'Y	1	371	S5-OP6-005-410	WORM	1
313	S5-OA4-001-020	G-ROLLER ASS'Y	2	372	S5-OP6-005-420	BRACKET,MOTOR	1
314	S5-OA4-001-710	BASE,INCL S ASS'Y	1	373	S5-OP0-004-670	COVER,DECK	1
315	S5-OA4-001-720	BASE,INCL T ASS'Y	1				
316	S5-OA4-001-850	P5-2 ARM ASS'Y	1	501	87-654-075-410	SCREW,TAP 2.6-10	1
317	S5-OA4-001-740	PINCH ROLLER BLOCK	1	502	S1-072-268-040	VT2+2.6-8	3
318	S5-OA4-001-750	TENSION ARM ASS'Y	1	503	87-743-073-010	VT2+2.6-6	3
319	S5-OA4-001-760	TENSION BAND ASS'Y	1	504	87-743-073-410	SCREW,TAP 2.6-6	3
				505	S1-0A1-268-040	SCREW,WASHER(A)M2.6-8	3
320	S5-OA4-001-780	PINCH ROLLER LEVER ASS'Y	1	506	S1-0B1-264-040	SCREW,WASHER(B)M2.6-4	1
321	S5-OA6-001-820	BRAKE T ASS'Y	1	507	87-261-035-410	SCREW,PAN M2-6	3
322	S5-OA6-001-830	CAP BRAKE ARM ASS'Y	1	508	87-261-032-410	SCREW,PAN M2-3	2
323	S5-OA9-002-130	LINK ASS'Y	1	509	87-258-091-010	U+M3-3	2
324	S5-OA9-002-160	LINK LEVER ASS'Y	1				
325	S5-OP2-002-610	LEVER,CLUTCH	1	510	S2-Q31-54C-5N0	PW,3.1-5.4-0.25	1
326	S5-OP2-002-620	RING,CLUTCH	1	511	S2-P26-600-5N0	PW(CUT)2.6-6-0.5	3
327	S5-OP2-002-630	GEAR,CLUTCH	1	512	S2-Q26-471-3N0	PW 2.6-4.7-0.13	3
328	S5-OP2-002-710	REEL,S	1	513	S2-P18-450-5N0	PW(CUT)1.8-4.5-0.5	1
329	S5-OP2-002-730	STOPPER,REEL S	1	514	S3-ETW-300-000	E-RING 3	2
				515	S1-0A1-235-040	SEMS A M2.3-5	1
330	S5-OP2-002-740	SPACER,LINK LEVER	1	516	S2-A26-750-510	WASHER 2.6-7.5-0.5	1
331	S5-OP3-001-780	GEAR,MAIN LOADING	1				
332	S5-OP3-001-790	GEAR,LOADING S	1	CP101	-----	CONN,PWB SIDE 52044-0445	1
333	S5-OP3-001-800	GEAR,LOADING T	1	CP102	-----	CONN,PWB SIDE 173979-2	1
334	S5-OP3-001-850	HOLDER,LOADING GEAR	1				
335	S5-OP4-004-720	ADJUST,TENSION	1	H5001	S5-23D-910-340	HEAD,AC HVMXA1072A	1
336	S5-OP4-004-730	HOLDER,TENSION	1	H5002	S5-43D-020-130	HEAD,FE	1
337	S5-OP4-004-740	LEVER,TENSION	1				
338	S5-OP4-004-750	COVER,P4	1	M101	S5-96P-780-010	MOTOR(LOADING)	1
339	S5-OP6-005-430	GEAR,JOINT	1	M2001	S5-94J-980-060	CAPSTAN DD UNIT EP15BA	1
				M2003	S5-89V-110-070	MICRO MOTOR EP14BD	1
340	S5-OP6-005-440	GEAR,MIDDLE	1				
341	S5-OP6-005-450	CAM,MAIN	1	PCB550	-----	DECK PCB ASS'Y	1
342	S5-OP6-005-460	CAM,P5	1				
343	S5-OP6-005-470	CAM,PINCH ROLLER	1	Q101	S0-007-003-200	PHOTO,TR RPT-38PB113	1
344	S5-OP6-005-480	ROD,MAIN	1	Q102	S0-007-003-200	PHOTO,TR RPT-38PB113	1
345	S5-OP7-000-350	REFLECTOR,LED	1				
346	S5-OP8-003-180	SPR,LOADING GEAR	2	UN4001	S4-D40-4B5-000	CYLINDER UNIT ASS'Y	1
347	S5-OP8-003-190	SPR,P5	1				
348	S5-OP8-003-210	SPR,BRAKE T	1				
349	S5-OP8-003-220	SPR,TENSION	1				
350	S5-OP8-003-230	SPR,CAP BRAKE	1				
351	S5-OP8-003-250	SPR,LOCKER	2				
352	S5-OP8-003-260	SPR,LINK	1				
353	S5-OP8-003-280	SPR,DAMPER	1				
354	S5-OP8-003-300	SPR,RING	1				
355	S5-OP8-003-320	SPR,S-S BRAKE	1				
356	S5-OP9-006-800	OPENER,CASS	1				
357	S5-OP9-006-830	CASS SIDE L	1				
358	S5-OP9-006-840	CASS SIDE R	1				
359	S5-OP9-007-020	TAPE GUIDE L(P,R)	1				

ELECTRICAL REPLACEMENT PARTS LIST

REF.NO.	PART NO.	DESCRIPTION	REF.NO.	PART NO.	DESCRIPTION
SYSCON PCB ASS'Y			*** CAPACITORS ***		
*** RESISTORS ***			C4079	87-015-075-040	CAP,E 10-16V
△ R502	S3-118-A01-OJ0	RES,M/O 1-2W	C4081	87-010-077-080	CAP,E 33UF-10V
△ R516	87-029-174-090	RES,FUSE 1-1/4W	C4084	87-015-695-080	CAP,E 1-50V
△ R517	S6-15U-439-1J0	RES,FUSE 390-1/4W	C4090	87-010-549-010	CAP,E 47-6.3V
△ R520	S6-558-418-1J0	RES,FUSE 180-1/4W	C4101	87-015-695-080	CAP,E 1-50V
R522	87-025-422-080	RES,M 3.3K-1/6W	C4503	87-010-235-080	CAP,E 470-16V
R523	87-022-629-080	RES,M/F 11K-1/6W	C4529	87-010-401-080	CAP,E 1-50V
R524	S4-25T-675-2F0	RES,M/F 7.5K-1/6W	C4530	87-010-401-080	CAP,E 1-50V
△ R548	S6-358-4R6-8K0	RES,FUSE 0.68-1/4W	C4539	87-010-380-080	CAP,E 47-16V
△ R1002	87-029-165-060	RES,FUSE 2.7-1W	C4545	87-010-235-080	CAP,E 470-16V(E)
R4017	87-025-431-080	RES,M 5.6K-1/6W	C4546	87-015-695-080	CAP,E 1-50V
			C4547	87-010-370-080	CAP,E 330-6.3V
			C4548	87-015-696-080	CAP,E 2.2-50
			C4553	87-015-695-080	CAP,E 1-50V
			C4802	87-015-695-080	CAP,E 1-50V
△ C505	SB-393-0ML-3M0	CAP,CER 0.0033-250V	C4804	87-010-076-070	CAP,E 22UF-6.3V
C506	S0-3T0-R6H-2K0	CAP,CER 220PF-1KV	C4806	87-015-695-080	CAP,E 1-50V
△ C507	SB-3LE-0ML-3M0	CAP,CER 0.0033-250V	C4808	87-010-549-010	CAP,E 47-6.3V
C508	87-010-246-010	CAP,E 47-35V	C4812	87-010-404-080	CAP,E 4.7-50V
C510	S0-2TF-H68-0M0	CAP,E 68-400V	C4815	87-010-549-010	CAP,E 47-6.3V
C515	87-010-560-080	CAP,E 10-50V	C4817	87-015-075-040	CAP,E 10-16V
C517	87-010-444-080	CAP,E 22UF-50V	C4820	87-010-549-010	CAP,E 47-6.3V
C518	S6-2AT-015-1M0	CAP,E 150UF-6.3V	C5502	87-010-380-080	CAP,E 47-16V
C519	87-010-560-080	CAP,E 10-50V	C5504	87-010-112-080	CAP,E 100-16V
C521	87-010-385-040	CAP,E 220UF-25V	C5509	87-010-560-080	CAP,E 10-50V
C522	87-010-980-010	CAP,E 330UF-16V	C5511	87-010-380-080	CAP,E 47-16V
C523	87-010-386-010	CAP,E 330UF-25V	C5513	87-015-075-040	CAP,E 10-16V
C525	87-010-685-080	CAP,E 330-16V	C5514	87-010-402-080	CAP,E 2.2-50V
C526	87-010-550-080	CAP,E 1000-6.3V	C5517	87-015-075-040	CAP,E 10-16V
C527	87-010-385-040	CAP,E 220UF-25V	C5519	87-010-380-080	CAP,E 47-16V
C529	87-015-075-040	CAP,E 10-16V	C5523	87-010-560-080	CAP,E 10-50V
C532	87-010-402-080	CAP,E 2.2-50V	C5527	87-015-075-040	CAP,E 10-16V
C534	87-010-550-080	CAP,E 1000-6.3V	C5528	87-015-075-040	CAP,E 10-16V
C651	87-015-677-010	CAP,E 100-6.3	C5529	87-015-075-040	CAP,E 10-16V
C659	87-010-549-010	CAP,E 47-6.3V	C5530	87-015-075-040	CAP,E 10-16V
C660	87-010-560-080	CAP,E 10-50V	C5531	87-015-075-040	CAP,E 10-16V
C1007	87-010-247-040	CAP,E 100UF-25V	C5532	87-015-075-040	CAP,E 10-16V
C1010	87-016-088-040	CAP,E 220-6.3V	C6003	87-010-549-010	CAP,E 47-6.3V
C1015	87-016-088-040	CAP,E 220-6.3V	C6007	87-010-550-080	CAP,E 1000-6.3V
C1022	87-015-683-080	CAP,E 33-16V	C6008	87-010-404-080	CAP,E 4.7-50V
C1023	87-015-075-040	CAP,E 10-16V	C6012	87-015-677-010	CAP,E 100-6.3
C1027	87-010-549-010	CAP,E 47-6.3V	C6013	87-010-550-080	CAP,E 1000-6.3V
C1028	87-016-040-010	CAP,E 0.047F-5.5V	C6602	87-010-549-010	CAP,E 47-6.3V
C1029	87-015-075-040	CAP,E 10-16V	C6609	87-010-402-080	CAP,E 2.2-50V
C1036	87-010-404-080	CAP,E 4.7-50V	C6610	87-010-402-080	CAP,E 2.2-50V
C1039	87-010-549-010	CAP,E 47-6.3V	C6615	87-015-695-080	CAP,E 1-50V
C1042	87-015-695-080	CAP,E 1-50V	C6625	87-010-549-010	CAP,E 47-6.3V
C4010	87-010-754-040	CAP,E 220UF-10V	C6626	87-010-549-010	CAP,E 47-6.3V
C4015	87-010-549-010	CAP,E 47-6.3V			
C4019	87-010-549-010	CAP,E 47-6.3V			*** DIODES ***
C4024	87-014-185-010	CAP,MPL 0.022-100V	D501	87-020-465-010	DIODE,1SS133T
C4025	87-010-403-080	CAP,E 3.3-50V	△ D502	S2-LXE-658-000	DIODE,1N4005E-G23
C4026	87-015-695-080	CAP,E 1-50V	△ D503	S2-LXE-658-000	DIODE,1N4005E-G23
C4033	87-010-076-040	CAP,E 22UF-6.3V	△ D504	S2-LXE-658-000	DIODE,1N4005E-G23
C4039	87-015-075-040	CAP,E 10-16V	△ D505	S2-LXE-658-000	DIODE,1N4005E-G23
C4041	87-015-695-080	CAP,E 1-50V	△ D507	87-A40-488-080	DIODE,1SS244T-77
C4042	87-010-404-080	CAP,E 4.7-50V	△ D512	S2-8T1-1DF-200	DIODE,11DF2N-TA2B2
C4043	87-010-402-080	CAP,E 2.2-50V	△ D513	S2-LXE-658-000	DIODE,1N4005E-G23
C4044	87-010-404-080	CAP,E 4.7-50V	△ D514	S1-3TG-MA0-200	DIODE,GMA-02-BT
C4045	87-010-400-080	CAP,E 0.47-50V	△ D515	S2-8T1-1ES-N10	DIODE,11ES1N-TA1B2
C4052	87-010-076-040	CAP,E 22UF-6.3V	D516	87-020-465-010	DIODE,1SS133T
C4053	87-010-404-080	CAP,E 4.7-50V	△ D517	S2-LKB-340-L00	DIODE,SB340L-6737
C4054	87-015-075-040	CAP,E 10-16V	△ D518	S2-3TG-P15-D00	DIODE,RGP15D-G23
C4059	87-010-549-010	CAP,E 47-6.3V	△ D519	87-002-743-080	ZENER,MTZJ33B T77
C4061	87-010-404-080	CAP,E 4.7-50V	△ D521	87-A40-499-080	ZENER,MTZJ27BT-77
C4073	87-010-549-010	CAP,E 47-6.3V	D525	S2-LXE-658-000	DIODE,1N4005E-G23
C4075	87-015-075-040	CAP,E 10-16V	△ D527	S9-7U0-4R7-1B0	ZENER,MTZJ4.7B
C4077	87-010-403-080	CAP,E 3.3-50V			

ELECTRICAL REPLACEMENT PARTS LIST

REF.NO.	PART NO.	DESCRIPTION	REF.NO.	PART NO.	DESCRIPTION
*** DIODES ***			*** COILS ***		
D528	S2-LXE-658-000	DIODE,1N4005E-G23	B502	S2-46T-035-840	CORE,BEADS BF40DTA-3.5
D530	S2-LXE-658-000	DIODE,1N4005E-G23	B503	S2-46T-035-840	CORE,BEADS BF40DTA-3.5
D531	S9-7U0-120-1B0	ZENER,MTZJ12B T-77	B504	S2-46T-035-840	CORE,BEADS BF40DTA-3.5
D532	S2-8TE-QS0-400	DIODE,11EQS04N-TA			
D1001	S0-106-000-600	LED,SID1050CM	L501	87-003-147-010	COIL,22UH
D1002	S2-LXE-658-000	DIODE,1N4005E-G23	L502	87-005-688-080	COIL,22UH
D1003	S9-2T1-120-B00	ZENER,RD12FB-T7	△ L503	S2-9T0-000-830	COIL,LINE FILTER 0R3A433F20
D1004	S2-LXE-658-000	DIODE,1N4005E-G23	L4003	87-003-152-010	COIL,100UH
D1006	87-020-465-010	DIODE,1SS133T	L4004	87-003-102-080	COIL,10UH
D1007	S2-LXE-658-000	DIODE,1N4005E-G23	L4005	S3-162-600-880	COIL,BIAS OSC 1626008
D4003	87-020-465-010	DIODE,1SS133T	L4006	87-003-112-010	COIL,1MH
D4502	S9-7U0-150-1B0	ZENER,MTZJ15B	L4007	87-003-285-010	COIL,39UH
D6601	SD-1RM-A36-700	DIODE,MA367	L4008	S2-1LA-627-1K0	COIL,270UH
*** ICS ***			L4009	87-003-152-010	COIL,100UH
△ IC501	87-A21-186-010	IC,STR-F6552	L4011	87-003-282-010	COIL,12UH
△ IC502	S0-Q90-431-L00	IC,NJM431L	L4012	87-003-154-080	COIL,220UH
IC651	S0-7F5-297-900	IC,BU2979K	L4013	87-003-152-010	COIL,100UH
△ IC1001	S0-7SQ-955-AN0	IC,BA6955AN	L4015	87-003-152-010	COIL,100UH
IC1002	S5-6F5-703-5A0	IC,OEC7035A	L4501	87-003-147-010	COIL,22UH
IC1004	SE-1J0-S31-AH0	IC,RE5VS31A	L4502	87-003-147-010	COIL,22UH
IC1099	S4-D40-4B0-150	IC,M24C08-BN6	L4503	87-003-152-010	COIL,100UH
IC4001	S0-4F3-821-7F0	IC,HA118217F	L4504	87-003-147-010	COIL,22UH
IC4501	S0-3F0-715-800	IC,LA7158M	L4505	87-003-152-010	COIL,100UH
IC4801	S5-3F4-775-M00	IC,LC74775M	L4506	87-003-147-010	COIL,22UH
IC5501	S0-KF7-960-5H0	IC,TDA9605H	L4507	87-003-147-010	COIL,22UH
IC6601	S0-KFA-987-4H0	IC,TDA9874H	L4508	87-003-147-010	COIL,22UH
*** TRANSISTORS ***			L4509	87-003-147-010	COIL,22UH
△ Q501	S0-025-004-800	PHOTO,COUPLER TLP621	L4510	87-003-147-010	COIL,22UH
Q502	87-026-287-080	TR,DTC143EKAT146	L4512	87-003-102-010	COIL,10UH
Q503	87-026-228-080	TR,DTA124EK	L4801	87-003-152-010	COIL,100UH
△ Q505	SD-3T0-073-400	TR,2SD734(E,F,G)-AA	L4802	87-003-152-010	COIL,100UH
△ Q507	SB-WT0-092-600	TR,2SB926(S,T)	L4803	87-003-152-010	COIL,100UH
△ Q508	SB-WT0-092-600	TR,2SB926(S,T)	L4806	87-003-148-010	COIL,33UH
Q509	89-324-122-080	TR,2SC2412KT	L4807	87-003-285-010	COIL,39UH
Q510	87-026-287-080	TR,DTC143EKAT146	L5501	87-003-152-010	COIL,100UH
△ Q511	SD-3T0-073-400	TR,2SD734(E,F,G)-AA	L5502	87-003-112-010	COIL,1MH
Q512	SB-WT0-092-600	TR,2SB926(S,T)	L6001	87-003-154-010	COIL,220UH
Q651	89-324-122-080	TR,2SC2412KT	L6002	87-003-152-010	COIL,100UH
Q1001	8Z-JU1-603-010	PHOTO,COUPLER GP1S566	L6004	S2-167-D10-1K0	COIL,100UH
Q1002	8Z-JU1-603-010	PHOTO,COUPLER GP1S566	L6601	S2-167-D10-1K0	COIL,100UH
Q1003	89-324-122-080	TR,2SC2412KT	L6602	S2-167-D10-1K0	COIL,100UH
Q1004	S0-02G-004-900	PHOTO,COUPLER GP1S94L	L6605	87-003-142-010	COIL,3.3UH
Q1005	S0-02G-004-900	PHOTO,COUPLER GP1S94L			
Q1006	87-026-236-080	TR,DTC124EK	*** TRANSFORMER ***		
Q1007	87-026-236-080	TR,DTC124EK	△ T501	S4-812-801-740	TRANS,SWITCHING 8128017
Q1008	SB-WT0-092-600	TR,2SB926(S,T)	*** JACKS ***		
Q1009	89-324-122-080	TR,2SC2412KT	J4204	S6-024-110-080	RCA,JACK JJP1195-010320
Q4003	SD-3T0-073-400	TR,2SD734(E,F,G)-AA	J4501	S6-3G1-000-410	SOCKET,21P 035_0_8083_0
Q4004	SD-3T0-073-400	TR,2SD734(E,F,G)-AA	*** SWITCH ***		
Q4005	87-026-228-080	TR,DTA124EK			
Q4006	87-026-613-080	TR,2SC2274K(E,F)	SW1001	S5-082-210-010	SW,LEAF SPVF130100
Q4007	87-026-613-080	TR,2SC2274K(E,F)	*** CONNECTORS ***		
Q4008	87-026-411-080	TR,DTC144EKAT146			
Q4501	87-026-235-010	TR,DTC114EK	CP506	S6-943-200-490	CORD EP CONNECTOR
Q4505	89-110-372-080	TR,2SA1037AK	CP652	S6-9E2-501-290	CONN,PWB SIDE
Q4506	87-026-236-080	TR,DTC124EK	CP1002	S6-9R7-500-280	CONN,PWB SIDE 52045-0545
Q4801	89-324-122-080	TR,2SC2412KT	CP1003	S6-972-805-900	CONN PWB SIDE TMC-J08P-B1
Q4802	89-110-372-080	TR,2SA1037AK	CP1004	S6-9R7-400-280	CONN,52045-0445
Q6001	89-324-122-080	TR,2SC2412KT	CP4001	S6-972-906-200	CONN PWB SIDE TOC-C09X-A1
Q6003	89-324-122-080	TR,2SC2412KT	CP4003	S6-971-203-200	CONN,TMC-TD2X-E1
*** COILS ***					
B501	S2-46T-035-840	CORE,BEADS BF40DTA-3.5			

ELECTRICAL REPLACEMENT PARTS LIST

REF.NO. PART NO. DESCRIPTION

*** CRYSTAL & CERAMIC OSCILLATORS ***

X1001	S0-OCT-012-070	X'TAL,HC-49/U-S
X1002	S0-0D3-2R8-010	X'TAL,32.768K
X4001	S0-0CF-4R4-010	X'TAL,HC-49/U
X6601	S0-OCT-024-010	X'TAL,HC-49/U

*** TUNER ***

△ TU6001 S1-626-070-100 RF UNIT,TMDB2-103A

*** FUSES ***

△ F501	S8-0PT-1R6-020	FUSE,21801.6
FH501	S6-710-T00-060	HOLDER,FUSE EYF-52B
FH502	S6-710-T00-060	HOLDER,FUSE EYF-52B

*** OTHERS ***

CP1001	S6-CH2-207-6A0	CORD CONN CH22076A
OS651	S7-710-000-130	REMOTE RECEIV PNA4612M00Y
V651	S9-677-9R0-050	FL,DISPLAY 7-MT-201GA

OPERATION 1 PCB ASS'Y

*** SWITCHES ***

SW601	S5-042-01T-320	SW,TACT
SW602	S5-042-01T-320	SW,TACT
SW603	S5-042-01T-320	SW,TACT
SW604	S5-042-01T-320	SW,TACT
SW605	S5-042-01T-320	SW,TACT
SW606	S5-042-01T-320	SW,TACT

OPERATION 2 PCB ASS'Y

*** DIODE ***

D601 S0-213-5Q1-600 LED,SLZ-345B-02

*** TRANSISTOR ***

Q601 87-026-286-010 TR,DTA143ES

*** SWITCHES ***

SW607	S5-042-01T-320	SW,TACT
SW608	S5-042-01T-320	SW,TACT
SW609	S5-042-01T-320	SW,TACT
SW610	S5-042-01T-320	SW,TACT

*** OTHER ***

CD602 S6-CH2-508-2A0 CORD CONN CH25082A

AND OTHERS

*** AC CORD ***

△ CD501 S2-066-358-170 CORD AC BUSH 06635817

サービス技術ニュース	
番号	連絡内容
G- -	
G- -	
G- -	

アイワ株式会社 〒110-8710 東京都台東区池之端1-2-11 ☎03(3827)3111 (代表)
AIWA CO.,LTD. 2-11, IKENOHATA 1-CHOME, TAITO-KU, TOKYO 110-8710, JAPAN TEL:03 (3827) 3111

Free Manuals Download Website

<http://myh66.com>

<http://usermanuals.us>

<http://www.somanuals.com>

<http://www.4manuals.cc>

<http://www.manual-lib.com>

<http://www.404manual.com>

<http://www.luxmanual.com>

<http://aubethermostatmanual.com>

Golf course search by state

<http://golfingnear.com>

Email search by domain

<http://emailbydomain.com>

Auto manuals search

<http://auto.somanuals.com>

TV manuals search

<http://tv.somanuals.com>