

# AT-8900, AT-9900, AT-9900s Switches Installation and Safety Guide



AT-8948  
AT-9924T  
AT-9924SP  
AT-9924T/4SP  
AT-9924Ts

Installation and Safety Guide for AT-8900, AT-9900, AT-9900s Switches  
Document Number C613-04052-00 REV B

© 2003-2005 Allied Telesyn Inc. All rights reserved. No part of this publication may be reproduced without prior written permission from Allied Telesyn Inc.

Allied Telesyn Inc. reserves the right to change specifications and other information in this document without prior written notice. The information provided herein is subject to change without notice. In no event shall Allied Telesyn Inc. be liable for any incidental, special, indirect, or consequential damages whatsoever, including but not limited to lost profits, arising out of or related to this manual or the information contained herein, even if Allied Telesyn Inc. has been advised of, known, or should have known, the possibility of such damages.

All company names, logos, and product designs that are trademarks or registered trademarks are the property of their respective owners.

## Contents

---

Models Covered by this Guide .....	4
Package Contents .....	4
Selecting a Site .....	5
Installing the Switch .....	6
Applying Power to the Switch .....	9
Connecting the Switch .....	11
Checking LEDs .....	12
Documentation CD .....	14
Standards .....	15
Electrical Safety Statements .....	16
Safety .....	17
Sicherheit .....	18
Sikkerhed .....	20
Veiligheid .....	22
Sécurité .....	24
Turvallisuus .....	26
Norme di Sicurezza .....	28
Sikkerhet .....	30
Segurança .....	32
Seguridad .....	34
Säkerhet .....	36
EC Declaration of Conformity .....	38

## Models Covered by this Guide

---

This document includes information about the following models:

- AT-8948
- AT-9924T
- AT-9924SP
- AT-9924T/4SP
- AT-9924Ts

You can download updates to this guide from [www.alliedtelesyn.com](http://www.alliedtelesyn.com)

## Package Contents

---

Depending on the switch model, one or more of the following is factory-fitted:

- power supply unit (PSU), AT-PWR01 either AC or DC, or AT-PWR02 AC
- fan-only module (FOM), AT-FAN01
- blanking plate

The following items are shipped with each switch. Contact your authorised distributor or reseller if any are damaged or missing.

- one AC power cord (AC model)
- one power cord retaining clip (AC model)
- one cable for connecting the switch to a terminal or PC
- one 19-inch rack-mount kit
- one Installation and Safety Guide
- one CD-ROM with complete documentation and utilities
- one warranty card

## Selecting a Site

---

You can install the switch in the following ways:

- in a standard 19-inch rack (see “Installing the Switch” on page 6)
- on a level surface such as a desktop or bench

When you install the switch, choose a site as follows:

- for AT-8900 and AT-9900 switches, one that maintains an ambient temperature from 0° C to 50° C (32° F to 122° F)  
for AT-9900s switches, one that maintains an ambient temperature from 0° C to 40° C (32° F to 104° F)
- allows adequate airflow around the switch and its vents
- is free of dust and moisture
- maintains humidity from 5% to 80% non-condensing
- has a reliable and earthed (grounded) power supply, preferably dedicated and filtered
- does not expose cabling to sources of electrical noise such as radio transmitters, broadband amplifiers, power lines, electric motors, and fluorescent fixtures
- permits easy access to the switch’s power and cable connections
- allows related network devices to be connected to the switch without exceeding maximum cable lengths specified in the Hardware Reference
- ensures that the switch is mounted evenly in the rack to prevent uneven mechanical loading of the rack

## Installing the Switch

---

The switch is heavier at the rear than at the front. Therefore, we recommend that you use the supplied 19-inch rack-mount kit to fully support the switch in a rack. Using this kit is essential if the front mounting flange on the rack is easily bent, or the switch is installed in areas subject to shocks such as earth tremors or heavy vibrations.

### Before you begin

- Read the safety information.

For your well-being and that of the equipment, read the safety information in this document. You can also download this document from the Documentation and Tools CD-ROM or from [www.alliedtelesyn.com](http://www.alliedtelesyn.com)

- Verify the package contents if you have not already done so.

See “Package Contents” on page 4. If any items are damaged or missing, contact your authorised distributor or reseller.

- Gather necessary tools and equipment.

You need a Phillips #2 screwdriver to adjust the retaining screws on the power supply unit (PSU) or fan-only module (FOM).

To install a DC version of the PSU, you need an appropriate DC power source, DC supply cable, ring connectors, and a crimp tool.

- Choose a suitable operating location.

Follow the guidelines described in “Selecting a Site” on page 5 to choose a suitable location.

- Decide whether two people are needed to mount the switch into the rack and tighten the screws (step 7).

- If you have an optional expansion module for the AT-9900s Series switch, install it in the switch first.

Refer to the *Expansion Module Installation Guide for the AT-9900s Series Switch* for details.



**Warning** Both AC and DC versions of this equipment must be earthed.

## Installing the switch using the 19-inch rack-mount kit

1. Ensure the rack has sufficient space for the switch and its cables.
2. If necessary, install cage nuts at the front and rear of the rack.
3. Unpack the switch and remove the rubber feet.
4. Screw the front brackets to the sides of the switch using the M4 screws that are supplied (see figure below).

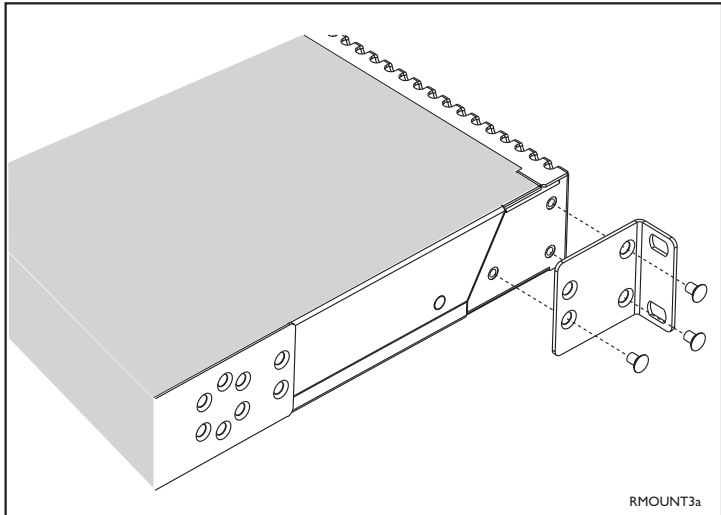

5. Measure the depth of the rack to determine the correct position to attach the rear brackets to the switch.
6. Screw the right rear and left rear brackets to the sides of the switch using the M4 screws that are supplied.
7. Mount the switch into the rack from the front, and attach it to the rack using rack mounting screws.

Two people may be required to safely support the switch until the brackets are screwed to the rack.

8. Fit the adjustable bracket extensions onto the rear brackets but do **not** tighten the nuts (see figures below).

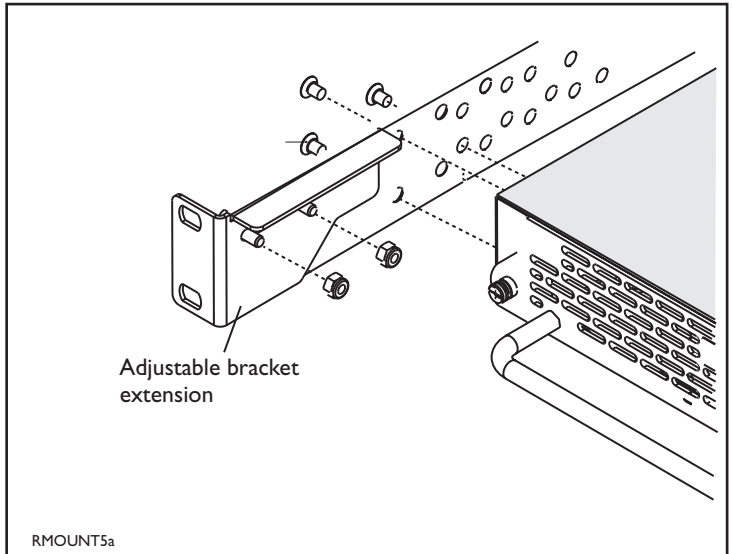
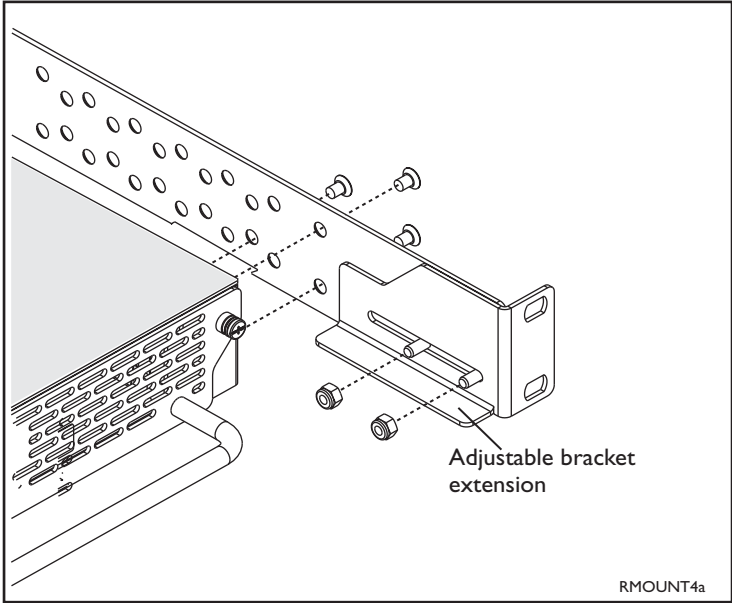



The adjustable bracket extensions are rotationally symmetrical when attached to the rear brackets. When viewed from the rear of the switch, the flanges on the bracket extensions are at the bottom on the right and at the top on the left. This allows adequate clearance when a power supply unit or fan-only module is removed from the switch.

9. Attach the adjustable bracket extensions to the rack using rack mounting screws.
10. Tighten the nuts that secure the adjustable bracket extensions to the rear brackets.
11. Check that all screws and nuts are fully tightened.

## Applying Power to the Switch

---

The switch has two bays in the rear. Your switch comes with one pre-installed power supply unit (PSU). Depending on the model, the switch also has one fan-only module (FOM) or one blanking panel over a power supply bay,

### AC power supply

Important information for service personnel:

- CAUTION: double pole/neutral fusing
- the rating of fuses FH101 and FH102 is 250 V, 5 A (AT-PWR01 only)

### Procedure for AC power supply

To apply power to the PSU, plug the AC power cord that is provided into the power inlet on the faceplate of the PSU. Then connect the power cord to the main power supply.

### DC supply cable and power supply

Supply cable specifications

- three-core cable is required
- minimum core size: 3.3 mm<sup>2</sup> (12 AWG) high strand count copper wire
- minimum cable rating: 600 V, 90 degrees C

Power supply specifications

- 40 to 60 V, 48 V nominal
- supports either positive grounded or negative grounded operation
- a 15 Amp certified/listed circuit breaker is required for circuit protection

## Procedure for DC power supply

Only trained and qualified personnel should connect a DC power supply.

For centralised DC power connection, the switch should be installed in **restricted access areas only** (such as dedicated equipment rooms or equipment closets) in accordance with Articles 110-16, 110-17, and 110-18 of the National Electrical Code, ANSI/NAPA 70.



**Warning** Ensure that the power supply cable is not live before starting.

1. Remove the transparent protective terminal cover.
2. Strip the supply cable wires to expose 7.5mm (0.31 in.) of bare conductor. Terminate the wire with a nylon insulated solderless ring tongue terminal, JST FN5.5-5 or equivalent, using a crimp tool.
3. Connect the ground wire to the ground terminal. Use the diagram on the rear panel of the switch to identify terminals. Tighten the terminal to between 2.4 and 4.0 Nm (21.3 and 35.4 lbf in).



**Caution** Check that the PSU terminals are wired to the correct polarity. A PSU will be damaged if incorrectly connected.

4. Connect the positive feed to the + (positive) terminal and the negative feed to the - (negative) terminal. Tighten the terminals to between 2.4 and 4.0 Nm (21.3 and 35.4 lbf in).
5. Ensure there are no exposed cable strands.
6. Replace the cover. You **must** replace the transparent plastic terminal cover before continuing.
7. Secure the supply cable to the rack framework or a similar object to ensure that connections are isolated from any force applied to the cable.
8. Ensure the circuit breaker for the supply circuit and the Run/Standby control on the PSU are **off**. Use a small diameter pin to press and release the Run/Standby control so that it is not pushed in (which is the Off position).
9. Connect the supply cable wires to the circuit breaker.
10. Turn on the PSU by pushing in the Run/Standby control with a small diameter pin.
11. Confirm that the switch is receiving power.

Check that at least one of the PSU LEDs on the front panel of the switch is lit green. If no LEDs light, refer to the Hardware Reference for troubleshooting information.

## Connecting the Switch

---

Before you begin these procedures, ensure that the switch has at least one power supply unit installed and operating. Another power supply unit or a fan-only module must be installed in the other bay.

### Using the CLI to configure a switch

1. Physically connect the terminal or PC to the ASYN0 port on the front panel of the switch.

For AT-8948 and AT-9900 switches, use the RJ-45 straight-through cable that is supplied.

2. Set communication parameters on your terminal or terminal emulation program to the following:

- bit rate: **9600**
- data bits: **8**
- parity: **None**
- stop bits: **1**
- flow control: **Hardware**

3. Check the power supply.

For AC models, ensure that the switch is receiving power (PWR LED is lit green).

For DC models, ensure that the Run/Standby switch is in the On or Run position and that the switch is receiving power (PWR LED is lit green).

4. Log in.

After the switch has booted, the login prompt is displayed. If not, press the Enter key two or three times.

When the switch boots for the first time, it automatically creates an account with manager privileges. The login name for the account is *manager* and the password is *friend*.

At the login prompt, enter the login name and password as follows:

```
Login: manager
Password: friend
```

The switch's command prompt is displayed for you to use the CLI to configure it. Refer to the Software Reference for more information about configuring the software.

5. Change the password.

Change the password as soon as possible because a manager account with the default password is a serious security risk. Remember the new password because there is no way to retrieve it if you forget it.

To change the account password, use the **set password** command.

6. Display help for commands as necessary.

To display a list of help topics, use the **help** command.

To display help on a specific topic, use the **help <topic>** command.

Alternatively, display a list of valid options by typing a question mark at the end of a partial command.

## Checking LEDs

---

Table 1 describes how LEDs on the switch report faults and operational activities.

Table 2 on page 14 describes how LEDs on power supply units and fan-only modules report faults and operational activities.

LEDs for Ethernet ports and Small Form Factor Pluggable (SFP) ports are described in the Hardware Reference.

Table 1: System LEDs

LED	State	Description
PSU 1	Green	PSU 1 is installed and supplying power to the switch. The voltage output is within specification.
	Red	PSU 1 is installed in the switch and has exceeded its recommended temperature threshold of 75° C (167° F), or the fan has failed. A FOM is installed in the switch and has failed. The bay is empty.
	Off	A FOM is installed and operating at an acceptable speed. For AT-9924T and AT-9924SP models, this LED is always off because a FOM is not required.

Table 1: System LEDs (Continued)

LED	State	Description
PSU 2	Green	PSU 2 is installed and supplying power to the switch. The voltage output is within specification.
	Red	PSU 2 is installed in the switch and has exceeded its recommended temperature threshold of 75° C (167° F), or the fan has failed. A FOM is installed in the switch and has failed. The bay is empty.
	Off	A FOM is installed and operating at an acceptable speed.
Fault	Red	The switch or management software is malfunctioning.
	1 Flash	One or more heatsink fans has failed or is operating below the recommended speed.
	6 Flashes	The switch's temperature has exceeded the recommended threshold. After flashing six times, the LED stops briefly, then repeats the sequence.
	Slow flashing at startup	The SDRAM (DIMM) has not been detected.
	Rapid flashing at startup	The SDRAM (DIMM) is not compatible with the switch.
CF	Green flashing	The CompactFlash memory card is active and should not be ejected. The card can be safely ejected when the LED remains off.
SD	Off	Secure Digital memory card. Not supported by 3.0.1 software.

Table 2: LEDs on the power supply unit and fan-only module

LED	State	Description
Fault	Red	The temperature on the PSU has exceeded the limit of 75° C (167° F), or the fan failed.
PWR	Green	A PSU is installed in the switch and is receiving power. A FOM does not have this LED.

## Documentation CD

The documentation CD-ROM bundled with each switch contains complete documentation for your switch as well as tools to manage it. The CD includes:

- the Hardware Reference, which provides detailed information on the switch and its hardware features.
- the Software Reference, which provides detailed information on configuring the switch and its software.
- the *Removable Power Supply and Fan Installation Guide*, which describes how to install power supply units and fan-only modules in the switch.
- this Installation and Safety Guide.
- AT-TFTP Server for Windows for downloading software releases.
- Adobe Acrobat Reader for viewing online documentation.

## Standards

This product meets the following standards:

Approval Agency and Requirement	
	UL60950-1 CAN/CSA-C22.2 No. 60950-1-03 EN60950-1 AS/NZS 60950
Electromagnetic Compliance	FCC CFR47 Part 15 Class A EN55022 Class A VCCI Class A AS/NZS CISPR22 Class A CNS 13438 Class A EN61000-3-2/3
Immunity	EN55024

### U.S. Federal Communications Commission

#### RADIATED ENERGY

Note: This equipment has been tested and found to comply with the limits for a Class A digital device pursuant to Part 15 of the FCC Rules. These limits are designed to provide reasonable protection against harmful interference when the equipment is operated in a commercial environment. This equipment generates, uses, and can radiate radio frequency energy and, if not installed and used in accordance with this instruction manual, may cause harmful interference to radio communications. Operation of this equipment in a residential area is likely to cause harmful interference in which case the user will be required to correct the interference at his own expense.

Note: Modifications or changes not expressly approved by the manufacturer or the FCC can void your right to operate this equipment.

### Canadian Department of Communications

This Class A digital apparatus meets all requirements of the Canadian Interference-Causing Equipment Regulations.

Cet appareil numérique de la classe A respecte toutes les exigences du Règlement sur le matériel brouilleur du Canada.

この装置は、クラスA情報技術装置です。この装置を家庭環境で使用すると電波妨害を引き起こすことがあります。この場合には使用者が適切な対策を講ずるよう要求されることがあります。

VCCI- A

#### 警告使用者：

這是甲類的資訊產品，在居住的環境中使用時，可能會造成射頻干擾，在這種情況下，使用者會被要求採取某些適當的對策。

BSMI- A

## Electrical Safety Statements

---

### Electrical Safety

IMPORTANT: This equipment must be installed in accordance with safety precautions (Safety, page 17).

### Elektrische Sicherheit

WICHTIG: Für die Installation dieses Gerätes ist die Einhaltung von Sicherheitsvorkehrungen erforderlich (Sicherheit, Seite 18).

### Elektrisk sikkerhed

VIGTIGT: Dette udstyr skal installeres i overensstemmelse med sikkerhedsadvarslerne (Sikkerhed, side 20).

### Elektrische veiligheid

BELANGRIJK: Dit apparaat moet in overeenstemming met de veiligheidsvoorschriften worden geïnstalleerd (Veiligheid, pagina 22).

### Sécurité électrique

IMPORTANT: Cet équipement doit être utilisé conformément aux instructions de sécurité (Sécurité, page 24).

### Sähköturvallisuus

TÄRKEÄÄ: Tämä laite on asennettava turvaohjeiden mukaisesti (Turvallisuus, sivu 26).

### Sicurezza elettrica

IMPORTANTE: questa apparecchiatura deve essere installata rispettando le norme di sicurezza (Norme di Sicurezza, pagina 28).

### Elektrisk sikkerhet

VIKTIG: Dette utstyret skal installeres i samsvar med sikkerhetsregler (Sikkerhet, side 30).

### Segurança eléctrica

IMPORTANTE: Este equipamento tem que ser instalado segundo as medidas de precaução de segurança (Segurança, página 32).

### Seguridad eléctrica

IMPORTANTE: La instalación de este equipo deberá llevarse a cabo cumpliendo con las precauciones de seguridad (Seguridad, página 34).

### Elsäkerhet

OBS! Alla nödvändiga försiktighetsåtgärder måste vidtas när denna utrustning används (Säkerhet, sida 36).



## Safety

---



**WARNING:** In a domestic environment this product may cause radio interference in which case the user may be required to take adequate measures.



**WARNING:** Class I Laser product.



**WARNING:** Do not stare into the laser beam.



**CAUTION:** Use of controls or adjustments of performance or procedures other than those specified herein may result in hazardous radiation exposure.



### ELECTRICAL NOTICES

#### **WARNING: ELECTRIC SHOCK HAZARD**

To prevent ELECTRIC shock, do not remove the cover. No user-serviceable parts inside. This unit contains HAZARDOUS VOLTAGES and should be opened only by a trained and qualified technician.



#### **LIGHTNING DANGER**

**DANGER:** DO NOT WORK on equipment or CABLES during periods of LIGHTNING ACTIVITY.



**CAUTION:** POWER CORD IS USED AS A DISCONNECTION DEVICE. TO DE-ENERGIZE EQUIPMENT, disconnect the power cord.



#### ELECTRICAL - TYPE CLASS I EQUIPMENT

THIS EQUIPMENT MUST BE EARTHED. Power plug must be connected to a properly wired earth ground socket outlet. An improperly wired socket outlet could place hazardous voltages on accessible metal parts.



PLUGGABLE EQUIPMENT, the socket outlet shall be installed near the equipment and shall be easily accessible.



**CAUTION:** Air vents must not be blocked and must have free access to the room ambient air for cooling.



**OPERATING TEMPERATURE:** AT-8900/AT-9900 switches are designed for a maximum ambient temperature of 50 degrees C. AT-9900s switches are designed for a maximum of 40 degrees C.



#### ELECTRICAL - AC MAINS CIRCUIT OVERLOADING

When installing product, consideration must be given to the accumulative nameplate ratings when connecting the equipment to the AC supply wiring.



**CAUTION:** MECHANICAL LOADING - Mounting of the equipment in the rack should be such that a hazardous condition is not achieved due to uneven loading.



Lithium Battery - Should be changed only by authorised service personnel.

**CAUTION:** Danger of explosion if battery is incorrectly replaced. Replace only with Lithium Battery, type CR2032, and dispose of in accordance with the manufacturer's recommendations and all local codes.



**ALL COUNTRIES:** Install product in accordance with local and National Electrical Codes.



**WARNING:** For centralized DC power connection, install only in a restricted access area.



A tray cable is required to connect the power source if the unit is powered by centralized DC power. The tray cable must be UL listed Type TC tray cable and rated at 600 V and 90 degrees C, with three conductors, minimum 12 AWG.



**WARNING:** Only trained and qualified personnel are allowed to install or replace this equipment.



**WARNING:** As a safety precaution, a 15 Amp circuit breaker should be installed at the supply end of the cable to be used with this LAN equipment.

Always connect the wiring to the LAN equipment first before connecting the wiring to the breaker. To avoid the danger of physical injury from electrical shock, do not work with HOT feeds. Always be sure that the breaker is in the Off position before connecting the wiring to the breaker.



**WARNING:** Do not strip more than the recommended amount of wire. Stripping more than the recommended amount can create a safety hazard by leaving exposed wire on the terminal block after installation.



**WARNING:** When installing this equipment, always ensure that the frame ground connection is installed first and disconnected last.



**WARNING: "Safety Hazard"** - Check to see if there are any exposed copper strands coming from the installed wires. When this installation is done correctly, there should be no exposed copper wire strands extending from the terminal block. Any exposed wiring can conduct harmful levels of electricity to persons touching the wires.



DC versions of this system will work with a positive grounded or negative grounded DC system.

## Sicherheit

---



**WARNING:** Bei Verwendung zu Hause kann dieses Produkt Funkstörungen hervorrufen. In diesem Fall müßte der Anwender angemessene Gegenmaßnahmen ergreifen.



**WARNUNG** Laserprodukt der Klasse I.



**WARNUNG** Nicht direkt in den Strahl blicken.



**ACHTUNG: GEFÄHRLICHE SPANNUNG**

Das Gehäuse nicht öffnen. Das Gerät enthält keine vom Benutzer wartbaren Teile. Das Gerät steht unter Hochspannung und darf nur von qualifiziertem technischem Personal geöffnet werden.



**GEFAHR DURCH BLITZSCHLAG**

**GEFAHR:** Keine Arbeiten am Gerät oder an den Kabeln während eines Gewitters ausführen.



**VORSICHT:** DAS NETZKABEL DIENT ZUM TRENNEN DER STROMVERSORGUNG. ZUR TRENNUNG VOM NETZ, KABEL AUS DER STECKDOSE ZIEHEN.



**GERÄTE DER KLASSE I**

DIESE GERÄTE MÜSSEN GEERDET SEIN. Der Netzstecker darf nur mit einer vorschrittsmäßig geerdeten Steckdose verbunden werden. Ein unvorschriftsmäßiger Anschluß kann die Metallteile des Gehäuses unter gefährliche elektrische Spannungen setzen.



**STECKBARES GERÄT:** Die Anschlußbuchse sollte in der Nähe der Einrichtung angebracht werden und leicht zugänglich sein."



**VORSICHT**

Die Entlüftungsöffnungen dürfen nicht versperrt sein und müssen zum Kühlen freien Zugang zur Raumluft haben.



**BETRIEBSTEMPERATUR:** AT-8900/AT-9900 produkt wurde für den Betrieb in einer Umgebungstemperatur von nicht mehr als 50 grad C entworfen.

AT-9900s produkt wurde für den Betrieb in einer Umgebungstemperatur von nicht mehr als 40 grad C entworfen.



**NETZSICHERUNG**

Bei der Installation muß der auf dem Typenschild angezeigte Nennwert des Gerätes für den Anschluß an das Netz beachtet werden.



**VORSICHT: RAHMENEINBAU**

Die Geräte müssen so in den Rahmen montiert werden, daß keine Gefahren durch unebenen inbau des Rahmens verursacht werden.



Lithium-Batterie - Sollte nur von einem geschulten qualifizierten Techniker ausgetauscht werden.

**VORSICHT:** Explosionsgefahr bei unsachgemäßem Austausch der Batterie.

Nur mit einer gleichen Batterie oder einem gleichwertigen Batterietyp nach Empfehlung des Herstellers ersetzen. Gebrauchte Batterien nach Anweisungen des Herstellers beseitigen.



**ALLE LÄNDER:** Installation muß örtlichen und nationalen elektrischen Vorschriften entsprechen.



**Warnung:** Bei zentralisierten gleichstromverbindungen sollte die installation nur an einem standort mit beschränktem zugang erfolgen.



**Hinweis:** Für den Anschluß der Stromquelle ist ein für den Einsatz in Kabelrinnen geeignetes Installationskabel (Tray Cable) erforderlich, falls die Einheit durch zentralisierten Gleichstrom angetrieben wird. Das Installationskabel muß ein dem UL-Standard entsprechendes Kabel des Typs TC mit einer Nennspannung von 600 V und einer Nenntemperatur von 90 grad C sein, das drei Leiter hat. Stärke mind. 12 AWG (American Wire Gage – amerikanische Einheit für Drahtdurchmesser).



**Warnung:** INSTALLATION UND WARTUNG DIESER EINRICHTUNG NUR DURCH AUSGEBILDETES FACHPERSONAL.



**Warnung:** Aus Sicherheitsgründen sollte am Netzteilende des mit dieser LAN-Einrichtung verwendeten Kabels ein 15-Ampere-Leistungsschalter installiert werden.

Nehmen Sie STETS zuerst die Verkabelung der LAN-Einrichtung vor, bevor Sie die Kabel an den Leistungsschalter anschließen. Arbeiten Sie nie mit SPANNUNGSFÜHRENDEN Kabeln, um Körperverletzungen durch Stromschlag zu vermeiden. Achten Sie stets darauf, daß sich der Leistungsschalter in der Position Off (Aus) befindet, bevor Sie Kabel an den Leistungsschalter anschließen.



**Warnung:** Ziehen Sie nicht mehr als die empfohlene Drahtlänge ab. Wird mehr als die empfohlene Länge abisoliert, stellt dies ein Sicherheitsrisiko dar, da auf dem Anschlußklemmblock nach der Installation möglicherweise freiliegende Drähte verbleiben.



**Warnung:** Bei der Installation dieser Einrichtung ist stets sicherzustellen, daß der Masseanschluß jeweils zuerst installiert und zuletzt getrennt wird.



**Warnung: "Sicherheitsrisiko"** Prüfen Sie, daß aus dem installierten Draht keine freiliegenden Kupferlitzen herausragen. Bei korrekter Installation sollten aus dem Anschlußklemmblock keine freiliegenden Kupferlitzen vorstehen. Freiliegende Kabel führen genug Spannung, um Personen zu gefährden, die diese Drähte berühren.



**Hinweis:** Dieses System kann mit positiv geerdeten oder negativ geerdeten Gleichstromsystemen betrieben werden.

## Sikkerhed

---



**ADVARSEL:** I et hjemligt miljø kunne dette produkt forårsage radio forstyrrelse. Bliver det tilfældet, påkræves brugeren muligvis at tage tilstrækkelige foranstaltninger.



**ADVARSEL** Laserprodukt av klasse I.



**ADVARSEL** Stirr ikke på strålen.

**ELEKTRISKE FORHOLDSREGLER****ADVARSEL: RISIKO FOR ELEKTRISK STØD**

For at forebygge ELEKTRISK stød, undlad at åbne apparatet. Der er ingen indre dele, der kan repareres af brugeren. Denne enhed indeholder LIVSFARLIGE STRØMSPÆNDINGER og bør kun åbnes af en uddannet og kvalificeret tekniker.

**FARE UNDER UVEJR**

**FARE: UNDLAD** at arbejde på udstyr eller KABLER i perioder med LYNAKTIVITET.



**ADVARSEL: DEN STRØMFØRENDE LEDNING BRUGES TIL AT AFBRYDE STRØMMEN. SKAL STRØMMEN TIL APPARATET AFBRYDES,** tages ledningen ud af stikket.

**ELEKTRISK - KLASSE I-UDSTYR**

DETTE UDSKYR KRÆVER JORDFORBINDELSE. Stikket skal være forbundet med en korrekt installeret jordforbunden stikkontakt. En ukorrekt installeret stikkontakt kan sætte livsfarlig spænding til tilgængelige metaldele.



UDSTYR TIL STIKKONTAKT, stikkontakten bør installeres nær ved udstyret og skal være lettilgængelig.



**ADVARSEL:** Ventilationsåbninger må ikke blokeres og skal have fri adgang til den omgivende luft i rummet for afkøling.



**BETJENINGSTEMPERATUR:** AT-8900/AT-9900 apparat er konstrueret til en omgivende temperatur på maksimum 50 grader C. AT-9900s apparat er konstrueret til en omgivende temperatur på maksimum 40 grader C.

**ELEKTRISK-OVERBELASTNING AF SPÆNDINGSKREDSLØBET**

Ved installation af produktet, bør der tages hensyn til den kumulative kapacitet der angives på navneskiltet, når udstyret forbindes med vekselstrømsledningen.



**ADVARSEL: MEKANISK OPSTILLING-**Udstyret skal opstilles i stativet, på en sådan måde, at der ikke opstår fare p.g.a. ujævn opstilling.



Lithium batteri - Bør kun udskiftes af uddannet og kvalificeret tekniker.

**ADVARSEL :** Eksplosionsfare, hvis batteriet udskiftes ukorrekt. Udskift kun med samme eller en tilsvarende type der anbefales af producenten. Kassér brugte batterier i overensstemmelse med producentens instruktioner.



**ALLE LANDE:** Installation af produktet skal ske i overensstemmelse med lokal og national lovgivning for elektriske installationer.



**Advarsel:** ETABLERES FORBINDELSEN TIL ET JÆVNSTRØMSNET, BØR INSTALLERING FORETAGES I ET OMRÅDE HVOR UVEDKOMMENDE IKKE HAR ADGANG.



**Bemærk:** Hvis switchen forbindes til jævnstrømsnet skal den føres med skinnekabel, der skal være UL mærket type TC normeret til 600 V, 90 grader C' med tre ledere af mindst tykkelse 12 AWG (amerikansk ledningsmål).



**Advarsel:** INSTALLERING OG UDSKIFTNING AF DETTE UDSTYR BØR KUN UDFØRES AF AUT. EL-INSTALLATØR.



**Advarsel:** Der bør indskydes en 15 A automatsikring på forsyningsenden af kablet til dette LAN-udstyr.

Man skal **ALTID** først forbinde ledningerne med LAN-udstyret inden de forbindes med automatsikringen. Ved ledningsarbejde skal strømmen altid være AFBRUDT til forebyggelse af fare for elektrisk stød. Man skal altid SLUKKE automatsikringen inden man forbinder ledninger med den.



**Advarsel:** Man bør ikke afisolere mere af ledningerne end anvist, for så kan sådanne blanke ledninger udgøre et faremoment efter montering på klemmerækken.



**Advarsel:** Ved installering af dette udstyr skal steljord altid forbindes først og aftages sidst.



**Advarsel: "Fare"** Se omhyggeligt efter om der stikker blanke kobbertråde ud fra klemmeforbindelserne. Ved korrekt montering er det ikke tilfældet. Enhver afisoleret leder kan lede farlig strømstyrke til personer, som kommer til at røre ved dem.



**Bemærk:** Dette udstyr kan køre både på jævnstrøm med positiv og med negativ jord.

## Veiligheid

---



**WAARSCHUWING:** Binnenshuis kan dit product radiostoring veroorzaken, in welk geval de gebruiker verplicht kan worden om gepaste maatregelen te nemen.



**WAARSHUWING** Klasse-I laser produkt.



**WAARCHUWING** Neit in de straal staren.



**WAARSCHUWINGEN MET BETREKKING TOT ELEKTRICITEIT**

**WAARSCHUWING:** GEVAAR VOOR ELEKTRISCHE SCHOKKEN

Verwijder het deksel niet, teneinde ELEKTRISCHE schokken te voorkomen. Binnenin bevinden zich geen onderdelen die door de gebruiker onderhouden kunnen worden. Dit toestel staat onder GEVAARLIJKE SPANNING en mag alleen worden geopend door een daartoe opgeleide en bevoegde technicus.



**GEVAAR VOOR BLIKSEMINSLAG**

**GEVAAR:** NIET aan toestellen of KABELS WERKEN bij BLIKSEM.



**WAARSCHUWING:** HET TOESTEL WORDT UITGESCHAKELD DOOR DE STROOMKABEL TE ONTKOPPELEN. OM HET TOESTEL STROOMLOOS TE MAKEN: de stroomkabel ontkoppelen.



**ELEKTRISCHE TOESTELLEN VAN KLASSE I**  
DIT TOESTEL MOET GEAARD WORDEN. De stekker moet aangesloten zijn op een juist geaarde contactdoos. Een onjuist geaarde contactdoos kan de metalen onderdelen waarmee de gebruiker eventueel in aanraking komt onder gevaarlijke spanning stellen.



**AAN TE SLUITEN APPARATUUR**, de contactdoos wordt in de nabijheid van de apparatuur geïnstalleerd en is gemakkelijk te bereiken.”



**OPGELET:** De ventilatiegaten mogen niet worden gesperd en moeten de omgevoerde lucht ongehinderd toelaten voor afkoeling.



**BEDRIJFSTEMPERATUUR:** De omgevingstemperatuur voor AT-8900/ AT-9900 produkt mag niet meer bedragen dan 50 graden C. De omgevingstemperatuur voor AT-9900s produkt mag niet meer bedragen dan 40 graden C.



**ELEKTRISCH: OVERBELASTING VAN WISSELSTROOM HOOFDCIRCUIT**  
Tijdens de installatie van het produkt dient men rekening te houden met de gecombineerde waarden op de naamplaatjes bij het aansluiten van het toestel op de wisselstroom-voedingsdraden.



**LOPGELET: MECHANISCH LADEN** - De montage van het toestel in het rek dient zo uitgevoerd te worden dat geen gevaar ontstaat door een ongelijke lading.



Lithium batterij. Mag alleen worden vervangen door een daartoe opgeleide en bevoegde technicus.

**OPGELET:** Gevaar voor ontploffing indien de batterij verkeerd wordt vervangen. Alleen vervangen door hetzelfde of een gelijkwaardig, door de fabrikant aanbevolen type.



**ALLE LANDEN:** het toestel installeren overeenkomstig de lokale en nationale elektrische voorschriften.



**Waarschuwing:** Bij GECENTRALISEERDE DC-AANSLUITING: INSTALLATIE UITSLUITEND UITVOEREN IN EEN GEBIED MET BEPERKTE TOEGANG.



**Opmerking:** U hebt een PVC/nylon-kabel nodig voor aansluiting op de voedingsbron als de eenheid van stroom wordt voorzien door een gecentraliseerde DC-voeding. De PVC/nylon-kabel moet een TC-kabel zijn (met een vermelding op de UL-lijst), die geschikt is voor 600 V en 90 graden C met drie geleiders en een minimumdikte van 12 AWG.



**Waarschuwing:** ALLEEN GESCHOOLD EN GEKVALIFICEERD PERSONEEL MAG DEZE APPARATUUR INSTALLEREN OF VERVANGEN.



**Waarschuwing:** Op de kabel die op de LAN-apparatuur wordt aangesloten dient een zekering van 15 amp te worden gemonteerd aan de zijde van de aansluiting op de voeding.

Sluit bedrading **ALTIJD** eerst op de LAN-apparatuur aan en pas daarna op de zekering. Voorkom het risico op een elektrische schok en schakel eerst de voeding uit. Controleer voordat u de bedrading op de zekering aansluit altijd of de zekering zich in de stand UIT bevindt.



**Waarschuwing:** Verwijder niet meer dan de aanbevolen hoeveelheid isolatiemateriaal. Als u meer dan de aanbevolen hoeveelheid verwijdert, kan dit een veiligheidsrisico veroorzaken doordat draden bloot blijven liggen na aansluiting op het blok.



**Waarschuwing:** Zorg er tijdens installatie van de apparatuur altijd voor dat de aardeaansluiting van het frame als eerste wordt geplaatst en als laatste wordt losgemaakt.



**Waarschuwing: “Veiligheidsrisico”** Controleer of er bij de aangesloten bedrading geen koper blootligt. Als de installatie juist is uitgevoerd, is er bij het aansluitblok geen koperdraad zichtbaar. Blootliggende bedrading kan schadelijke elektriciteitsniveaus geleiden naar personen die met de draden in aanraking komen.



**Opmerking:** Dit systeem werkt met positief geaarde of negatief geaarde DC-systemen.

## Sécurité

---



**MISE EN GARDE :** dans un environnement domestique, ce produit peut provoquer des interférences radioélectriques. Auquel cas, l'utilisateur devra prendre les mesures adéquates.



**ATTENTION** Produit laser di classe I.



**ATTENTION** Ne pas fixer le faisceau des yeux.



### INFORMATION SUR LES RISQUES ÉLECTRIQUES

#### AVERTISSEMENT: DANGER D'ÉLECTROCUTION

Pour éviter toute ÉLECTROCUTION, ne pas ôter le revêtement protecteur du matériel. Ce matériel ne contient aucun élément réparable par l'utilisateur. Il comprend des TENSIONS DANGEREUSES et ne doit être ouvert que par un technicien dûment qualifié.





**DANGER DE Foudre**

**DANGER:** NE PAS MANIER le matériel ou les CÂBLES lors d'activité orageuse.



**ATTENTION:** LE CORDON D'ALIMENTATION SERT DE MISE HORS CIRCUIT. POUR COUPER L'ALIMENTATION DU MATÉRIEL, débrancher le cordon.



**ÉQUIPEMENT DE CLASSE I ÉLECTRIQUE**

CE MATÉRIEL DOIT ÊTRE MIS A LA TERRE. La prise de courant doit être branchée dans une prise femelle correctement mise à la terre car des tensions dangereuses risqueraient d'atteindre les pièces métalliques accessibles à l'utilisateur.



EQUIPEMENT POUR BRANCHEMENT ELECTRIQUE, la prise de sortie doit être placée près de l'équipement et facilement accessible”.



**ATTENTION:** Ne pas bloquer les fentes d'aération, ceci empêcherait l'air ambiant de circuler librement pour le refroidissement.



**TEMPÉRATURE DE FONCTIONNEMENT:** AT8900/AT-9900 est capable de tolérer une température ambiante maximum de ou 50 degrés C. AT-9900s est capable de tolérer une température ambiante maximum de ou 40 degrés C.



**SURCHARGE DES CIRCUITS PRINCIPAUX DE COURANT ALTERNATIF ÉLECTRIQUE**

Lors de l'installation du matériel, il faut prendre en compte la somme des puissances indiquées sur les étiquettes au moment de connecter le matériel à une source de courant alternatif.



**ATTENTION :** RÉPARTITION DE LA CHARGE MÉCANIQUE - Le montage du matériel dans le bâti doit être effectué de telle manière que la répartition de la charge mécanique ne pose aucun danger.



Pile en Lithium-Doit uniquement être remplacée par un technicien dûment qualifié

**ATTENTION :** Un danger d'explosion existe en cas de remplacement incorrect de la pile. Remplacer uniquement avec une pile du même type ou d'un type recommandé par le fabricant. Mettre au rebut les piles usagées conformément aux instructions du fabricant).



**POUR TOUS PAYS:** Installer le matériel conformément aux normes électriques nationales et locales.



**Avertissement:** POUR UNE CONNEXION A UNE SOURCE D'ALIMENTATION C.C. CENTRALISEE, L'INSTALLATION DOIT ETRE UNIQUEMENT EFFECTUEE DANS UNE ZONE D'ACCES LIMITE.



**Remarque:** Un câble de chariot est requis pour connecter la source de courant si l'unité est alimentée par une source de C.C. centralisée. Il doit s'agir d'un câble agréé UL de type TC, d'une puissance de 600 V et de 90 degrés C, avec trois fils conducteurs et un calibre minimum de 12 AWG (norme américaine exprimant la section des fils).



**Avertissement:** SEUL UN PERSONNEL QUALIFIE ET ENTRAINE EST AUTORISE A INSTALLER OU REMPLACER CET EQUIPEMENT.



**Avertissement:** Par mesure de sécurité, un disjoncteur de 15 A doit être installé au point d'alimentation électrique du câble devant être utilisé avec cet équipement de réseau local (LAN).

Connectez **TOUJOURS** le câblage à l'équipement LAN avant de le connecter au disjoncteur. Pour éviter tout risque de blessure corporelle par électrocution, ne travaillez pas lorsque le matériel est sous tension. Assurez-vous toujours que le disjoncteur est bien en position d'ARRET avant de le connecter au câblage.



**Avertissement:** Ne coupez pas une quantité de câble supérieure à celle qui est recommandée. Cela pourrait constituer un risque de sécurité en laissant du câblage à nu sur le bornier après l'installation.



**Avertissement:** Lors de l'installation de cet équipement, vérifiez toujours que la connexion de terre du châssis est installée en premier et débranchée en dernier.



**Avertissement: "Risque de sécurité"** Vérifiez qu'aucun fil de cuivre dénudé ne sort du câble installé. Lorsque cette installation est effectuée correctement, aucun fil de cuivre ne devrait dépasser du bornier. Tout câblage dénudé peut être conducteur de tensions dangereuses pour les personnes touchant les câbles.



**Remarque:** Ce système peut fonctionner avec des systèmes C.C. dotés d'une mise à la terre positive ou négative.

## Turvallisuus

---



**VAROITUS:** Kotiolosuhteissa tämä laite voi aiheuttaa radioaaltojen häiriötä, missä tapauksessa laitteen käyttäjän on mahdollisesti ryhdyttävä tarpeellisiin toimenpiteisiin.



**VAROITUS** Luokan I Lasertuote.



**VAROITUS** Älä katso säteeseen.



### SÄHKÖÖN LIITTYVIÄ HUOMAUTUKSIA

**VAROITUS:** SÄHKÖISKUVAARA

Estääksesi SÄHKÖISKUN älä poista kantta. Sisällä ei ole käyttäjän huollettavissa olevia osia. Tämä laite sisältää VAARALLISIA JÄNNITTEITÄ ja sen voi avata vain koulutettu ja pätevä teknikko.



**SALAMANISKUVAARA**

**HENGENVAAARA:** ÄLÄ TYÖSKENTELE laitteiden tai KAAPELEIDEN KANSSA SALAMOINNIN AIKANA.



**HUOMAUTUS:** VIRTAJOHTOA KÄYTETÄÄN

VIRRANKATKAISULAITTEENA. VIRTA KATKAISTAAN irrottamalla virtajohto.



**SÄHKÖ - TYYPPILUOKAN I LAITTEET**

TÄMÄ LAITE TÄYTY MAADOITTAA. Pistoke täytyy liittää kunnollisesti maadoitettuun pistorasiaan. Virheellisesti johdotettu pistorasia voi altistaa metalliosat vaarallisille jännitteille.



PISTORASIAAN KYTKETTÄVÄ LAITE; pistorasia on asennettava laitteen lähelle ja siihen on oltava esteetön pääsy.”



**HUOMAUTUS:** Ilmavaihtoreikiä ei pidä tukkia ja niillä täytyy olla vapaa yhteys ympäröivään huoneilmaan, jotta ilmanvaihto tapahtuisi.



**KÄYTTÖLÄMPÖTILA:** Tämä AT-8900/AT-9900 katkaisin on suunniteltu ympäröivän ilman maksimilämpötilalle 50° C. Tämä AT-9900s tuote on suunniteltu ympäröivän ilman maksimilämpötilalle 40° C.



**SÄHKÖ-VAIHTORVIRTASÄHKÖPIIRIN YLIKUORMITUS**

Tuotetta asennettaessa on otettava huomioon osien nimikilvissä osoitettu teho silloin kun osat liitetetään vaihtovirtaverkkoon.



**HUOMAUTUS:** MEKAANINEN KUORMITUS--Osien asennuksen alustaan tulee tapahtua siten, että epätasainen kuormitus ei aiheuta vaaraa.



Litiumparisto - Vaihdon voi suorittaa vain koulutettu ja pätevä teknikko.

**Varoitus:** Räjähdyksvaara, jos paristo on vaihdettu väärin. Vaihda vain samaan tai vastaavaan tyyppiin, jota valmistaja suosittelee. Hävitä käytetyt paristot valmistajan ohjeiden mukaan.



**KAIKKI MAAT:** Asenna tuote paikallisten ja kansallisten sähköturvallisuusmääräysten mukaisesti.



**Varoitus:** KESKITETTY TASAVIRTAKYTKENTÄ ASENNETTAVA AINOASTAAN TILAAN, JOHON ON RAJOITETTU PÄÄSY.



**Huomaa:** Virtalähteen kytkemiseen tarvitaan levykaapeli, jos yksikkö saa tehonsa keskitetystä tasavirtalähteestä. Levykaapelin on oltava UL-luetteloitu tyyppiin TC levykaapeli ja nimellisarvoiltaan 600 V ja 90° C, kolmijohtiminen, minimi 12 AWG (American Wire Gauge -lankamitta).



**Varoitus:** TÄMÄN LAITTEEN SAA ASENTAA TAI VAIHTAA AINOASTAAN KOULUTETTU JA AMMATTITAITOINEN HENKILÖKUNTA.



**Varoitus:** Tämän LAN-laitteen kanssa käytettävän kaapelin syöttöpäähän tulee turvallisuuksyistä asentaa 15 A virrankatkaisin.

Yhdistä johdot AINA ensin LAN-laitteeseen ennen virrankatkaisimeen kytkemistä. Sähköiskusta johtuvien vammojen välttämiseksi älä käsittele JÄNNITTEELLISIÄ johtoja. Varmista aina, että virrankatkaisin on pois päältä (off) ennen kuin yhdistät johdot katkaisimeen.



**Varoitus:** Älä poista johtimesta päällystettyä enempää kuin on suositeltu. Päällysteen poistaminen suositusta pidemmältä matkalta voi aiheuttaa turvallisuusriskin, sillä riviliittimeen jää asennuksen jälkeen paljaita johtimia.



**Varoitus:** Kun asennat tätä laitetta, varmista aina, että runkomaadoitettu liitin kytketään ensin ja irrotetaan viimeiseksi.



**Varoitus:** Turvallisuusriski Tarkista, ettei asennetusta johtimesta näy paljaita kuparisäikeitä. Kun asennus suoritetaan oikein, riviliittimestä ei pitäisi näkyä paljaita kuparijohdinsäikeitä. Paljaat johtimet voivat aiheuttaa sähköiskuvaaran, jos niihin kosketaan.



**Huomaa:** Tämä järjestelmä toimii positiivisesti tai negatiivisesti maadoitettujen tasavirtajärjestelmien kanssa.

## Norme di Sicurezza

---



**AVVERTENZA:** in ambiente domestico questo prodotto potrebbe causare radio interferenza. In questo caso potrebbe richiedersi all'utente di prendere gli adeguati provvedimenti.



**AVVERTENZA** Prodotto laser di Classe I.



**AVERTENZA** Non fissare il raggio con gli occhi.



### AVVERTENZE ELETTRICHE

#### ATTENZIONE: PERICOLO DI SCOSSE ELETTRICHE

Per evitare SCOSSE ELETTRICHE non asportare il coperchio. Le componenti interne non sono riparabili dall'utente. Questa unità ha TENSIONI PERICOLOSE e va aperta solamente da un tecnico specializzato e qualificato.



#### PERICOLO DI FULMINI

**PERICOLO:** NON LAVORARE sul dispositivo o sui CAVI durante PRECIPITAZIONI TEMPORALESCHIE.



**ATTENZIONE:** IL CAVO DI ALIMENTAZIONE È USATO COME DISPOSITIVO DI DISATTIVAZIONE. PER TOGLIERE LA CORRENTE AL DISPOSITIVO staccare il cavo di alimentazione.



**ELETTRICITÀ - DISPOSITIVI DI CLASSE I**

QUESTO DISPOSITIVO DEVE AVERE LA MESSA A TERRA. La spina deve essere inserita in una presa di corrente specificamente dotata di messa a terra. Una presa non cablata in maniera corretta rischia di scaricare una tensione pericolosa su parti metalliche accessibili.



APPARECCHIATURA COLLEGABILE, la presa va installata vicino all'apparecchio per risultare facilmente accessibile”.



**ATTENZIONE:** le prese d'aria non vanno ostruite e devono consentire il libero ricircolo dell'aria ambiente per il raffreddamento.



**TEMPERATURA DI FUNZIONAMENTO:** AT-8900/AT-9900 prodotto è concepito per una temperatura ambientale massima di 50 gradi C. AT-9900s prodotto è concepito per una temperatura ambientale massima di 40 gradi C.



**ELETTRICITÀ - SOVRACCARICO DEL CIRCUITO DI RETE A C.A.**

Durante l'installazione ed il collegamento del dispositivo alla rete di alimentazione a corrente alternata, è necessario tenere in considerazione le capacità cumulative riportate sulla targhetta.



**ATTENZIONE:** CARICAMENTO MECCANICO - Il montaggio del dispositivo sul supporto va effettuato in maniera tale da evitare qualsiasi potenziale condizione di pericolo eventualmente dovuta al montaggio irregolare.



Batteria al litio - Va sostituita solo da un tecnico specializzato e qualificato.

**ATTENZIONE:** l'errata sostituzione della batteria può causare pericolo di esplosioni. Sostituire solamente con lo stesso tipo o con uno equivalente raccomandato dal produttore. Eliminare le batterie usate secondo le istruzioni del produttore.



**TUTTI I PAESI:** installare il prodotto in conformità delle vigenti normative elettriche nazionali.



**Avvertenza:** AI FINI DEL COLLEGAMENTO CENTRALIZZATO DI ALIMENTAZIONE A CC, INSTALLARE SOLO IN UN'AREA AD ACCESSO LIMITATO.



**Nota:** Se l'unità è alimentata a corrente continua centralizzata, per collegare l'alimentatore è necessario un cavo a piatto di tipo TC, listato UL, avente caratteristiche nominali di tensione e temperatura di 600 V e 90gradi C, tre conduttori ed un diametro minimo di 12 AWG.



**Avvertenza:** L'INSTALLAZIONE E LA SOSTITUZIONE DI QUESTA APPARECCHIATURA DEVONO ESSERE EFFETTUATE SOLAMENTE DA PERSONALE SPECIALIZZATO E QUALIFICATO.



**Avvertenza:** A titolo di cautelativo, installare un interruttore di sicurezza da 15 ampere sull'estremità in entrata del cavo di alimentazione di questa apparecchiatura LAN.

Collegare **SEMPRE il cablaggio** prima all'apparecchiatura LAN e poi all'interruttore. Per evitare i infortuni causati da folgorazione, non lavorare su cavi SOTTO TENSIONE. Prima di collegare il cavo all'interruttore di sicurezza, accertarsi sempre che quest'ultimo sia disinserito.



**Avvertenza:** Per evitare i possibili pericoli associati all'esposizione dei fili sulla morsettiera dopo l'installazione, non rimuovere l'isolamento oltre le misure specificate.



**Avvertenza:** Quando si installa questo apparecchio, accertarsi sempre che il collegamento a massa del telaio sia sempre il primo ad essere effettuato e l'ultimo ad essere scollegato.



**Avvertenza: "Pericolo!"** Controllare che il filo installato non abbia trefoli in rame esposti. Se l'installazione è stata effettuata in modo corretto, non vi deve protrudere dalla morsettiera alcun trefolo in rame esposto. In caso di contatto, un filo esposto può condurre livelli di elettricità pericolosi a quanti lo tocchino.



**Nota:** Questo sistema funziona con sistemi a CC con massa positiva o negativa.

## Sikkerhet

---



**ADVARSEL:** Hvis dette produktet benyttes til privat bruk, kan produktet forårsake radioforstyrrelse. Hvis dette skjer, må brukeren ta de nødvendige forholdsregler.



**ADVARSEL** Laserprodukt av klasse I.



**ADVARSEL** Stirr ikke på strålen.



### ELEKTRISITET

**ADVARSEL: FARE FOR ELEKTRISK SJOKK**

For å unngå ELEKTRISK sjokk, må dekslet ikke tas av. Det finnes ingen deler som brukeren kan reparere på innsiden. Denne enheten inneholder FARLIGE SPENNINGER, og må kun åpnes av en faglig kvalifisert tekniker.



### FARE FOR LYNNEDSLAG

**FARE:** ARBEID IKKE på utstyr eller KABLER i TORDENVÆR.



**FORSIKTIG:** STRØMLEDNINGEN BRUKES TIL Å FRAKOBLE UTSTYRET. FOR Å DEAKTIVISERE UTSTYRET, må strømforsyningen kobles fra.



ELEKTRISK - TYPE I- KLASSE UTSTYR

DETTE UTSTYRET MÅ JORDES. Strømkontakten må være tilkopleet en korrekt jordet kontakt. En kontakt som ikke er korrekt jordet kan føre til farlig spenninger i lett tilgjengelige metalleder.



UTSTYR FOR STIKKONTAKT. Stikkontakten skal monteres i nærheten av utstyret og skal være lett tilgjengelig.”



**FORSIKTIG:** Lufteventilene må ikke blokkeres, og må ha fri tilgang til luft med romtemperatur for avkjøling.



**DRIFTSTEMPERATUR:** AT-8900/AT-9900 produktet er konstruert for bruk i maksimum romtemperatur på 50 grader C. AT-9900s produktet er konstruert for bruk i maksimum romtemperatur på 40 grader C.



**ELEKTRISK OVERBELASTNING PÅ AC HOVEDKRETSLØP**

Når produktet installeres, må de samlede navneplateverdier kontrolleres nøye når strøm påsettes.



**FORSIKTIG: MEKANISK LASTNING** Installering av utstyret på hyllen må utføres på en slik måte at ingen farlige situasjoner oppstår som en følge av ujevn lastning.



Litiumbatteri — Må kun byttes ut av en faglig kvalifisert tekniker.

**FORSIKTIG:** Eksplosjonsfare hvis batteriet feilinnsettes. Batteriet må bare erstattes med samme type eller en tilsvarende type som er anbefalt av fabrikanten. Batteriene må kasseres i samsvar med fabrikantens instruksjoner.



**ALLE LAND:** Produktet må installeres i samsvar med de lokale og nasjonale elektriske koder.



**Advarsel: VED TILKOPLING TIL ET LIKESTRØMSNETT, SKAL DU BARE MONTERE UTSTYRET PÅ ET STED HVOR UVEDKOMNE IKKE HAR ADGANG.**



**Merknad:** En kanalkabel er nødvendig for å kople til strømkilden hvis enheten drives av strøm fra et likestrømsnett. Kanalkabelen må være utstyrt med UL-merke med type TC, normert for 600 V og 90 grader C med tre ledere som har en tykkelse på minst 12AWG (amerikansk ledningsmål).



**Advarsel: DETTE UTSTYRET SKAL BARE MONTERES ELLER SKIFTES UT AV KVALIFISERT PERSONELL SOM HAR GJENNOMGÅTT OPPLÆRING.**



**Advarsel:** Av sikkerhetshensyn bør en automatsikring på 15 A monteres i forsyningsenden av kabelen som skal brukes sammen med dette LAN-utstyret.

Du skal ALLTID først kople ledningene til LAN-utstyret før du kople ledningene til automatsikringen. Arbeid aldri med ledninger uten at strømmen er slått av, ettersom det ellers kan være fare for personskader som følge av elektrisk støt. Pass alltid på at automatsikringer er slått AV før du kople ledningene til automatsikringen.



**Advarsel:** Du skal ikke avisolere mer av ledningen enn det som er anbefalt. Dersom du avisolere mer enn det som er anbefalt, kan dette forårsake en sikkerhetsfare, ettersom det vil finnes uisolert ledning på rekkeklemmen etter montering.



**Advarsel:** Når du monterer dette utstyret, skal du alltid passe på at forbindelsen til rammejordingen monteres først og koples fra sist.



**Advarsel: “Sikkerhetsfare”** Kontroller om uisolerte koppertråder stikker ut av den monterte ledningen. Hvis monteringen er riktig utført, skal det ikke finnes uisolerte kobbertråder som stikker ut fra rekkeklemmen. Uisolerte ledninger kan lede skadelige mengder strøm til personer som berører ledningene.



**Merknad:** Systemet fungerer med positivt og negativt jordede likestrømssystemer.

## Segurança

---



**AVISO:** Num ambiente doméstico este produto pode causar interferência na radiorrecepção e, neste caso, pode ser necessário que o utente tome as medidas adequadas.



**AVISO** Produto laser de classe I



**AVISO** Não olhe fixamente para o raio.



### **AVISOS SOBRE CARACTERÍSTICAS ELÉTRICAS**

#### **ATENÇÃO: PERIGO DE CHOQUE ELÉTRICO**

Para evitar CHOQUE ELÉTRICO, não retire a tampa. Não contém peças que possam ser consertadas pelo usuário. Este aparelho contém VOLTAGENS PERIGOSAS e só deve ser aberto por um técnico qualificado e treinado.



#### **PERIGO DE CHOQUE CAUSADO POR RAIOS**

**PERIGO:** NÃO TRABALHE no equipamento ou nos CABOS durante períodos suscetíveis a QUEDAS DE RAIOS.



**CUIDADO:** O CABO DE ALIMENTAÇÃO É UTILIZADO COMO UM DISPOSITIVO DE DESCONEXÃO. PARA DESELETRIFICAR O EQUIPAMENTO, desconecte o cabo de ALIMENTAÇÃO.



**ELÉTRICO - EQUIPAMENTOS DO TIPO CLASSE I**  
DEVE SER FEITA LIGAÇÃO DE FIO TERRA PARA ESTE EQUIPAMENTO. O plugue de alimentação deve ser conectado a uma tomada com adequada ligação de fio terra. Tomadas sem adequada ligação de fio terra podem transmitir voltagens perigosas a peças metálicas expostas.



**EQUIPAMENTO DE LIGAÇÃO,** a tomada eléctrica deve estar instalada perto do equipamento e ser de fácil acesso.”



**CUIDADO:** As aberturas de ventilação não devem ser bloqueadas e devem ter acesso livre ao ar ambiente para arrefecimento adequado do aparelho.





**TEMPERATURA DE FUNCIONAMENTO:** AT-8900/AT-9900 produto foi projetado para uma temperatura ambiente máxima de 50 graus C. AT-9900s produto foi projetado para uma temperatura ambiente máxima de 40 graus C.



**ELÉTRICO - SOBRECARGA DA REDE DE CORRENTE ALTERNADA (AC)**  
Antes de instalar o produto, verifique o efeito cumulativo da conexão de diversos aparelhos à rede de corrente alternada através das etiquetas que indicam potência ou amperagem.



**CUIDADO: CARREGAMENTO** - O equipamento deverá ser montado no suporte de montagem de forma tal que não cause perigo devido a carregamento não uniforme.



Bateria de lítio - Só deve ser trocada por técnico qualificado e treinado.  
**CUIDADO:** Se a bateria não for devidamente instalada há perigo de explosão. Substitua somente pelo mesmo tipo ou equivalente, conforme recomendado pelo fabricante. Descarte baterias usadas, de acordo com as instruções fornecidas pelo fabricante.



**TODOS OS PAÍSES:** Instale o produto de acordo com as normas nacionais e locais para instalações elétricas.



**Aviso: PARA UMA LIGAÇÃO CC CENTRALIZADA, INSTALE APENAS NUMA ZONA DE ACESSO RESTRITO.**



**Nota:** É necessário um cabo de bandeja para ligar a fonte de energia se a unidade for alimentada por um fonte CC centralizada. O cabo de bandeja deve fazer parte da lista UL do Tipo TC cabo de bandeja para 600 V e 90 graus C, com três condutores, com um mínimo de 12 AWG.



**Aviso: SÓ PESSOAL TREINADO E QUALIFICADO PODE INSTALAR OU SUBSTITUIR ESTE EQUIPAMENTO.**



**Aviso:** Como medida de precaução, deve instalar-se um disjuntor de 15 Amp na extremidade de alimentação do cabo a ser usado com este equipamento LAN.

Ligue **SEMPRE** os cabos ao equipamento LAN primeiro antes de os ligar ao disjuntor. Para evitar o perigo de ferimentos por choque eléctrico, não trabalhe com alimentadores LIGADOS. Verifique sempre se o disjuntor está na posição OFF (desligado) antes de ligar os cabos ao mesmo.



**Aviso:** Não corte mais fio do que recomendado. Cortar mais do que o recomendado pode ser perigoso, por deixar fio exposto no terminal depois da instalação.



**Aviso:** Ao ligar este equipamento, instale sempre primeiro a ligação à terra e desligue-a sempre em último.



**Aviso: “Perigo”** Verifique se há algum fio de cobre exposto a sair do fio instalado. Quando esta instalação é feita correctamente não deve haver qualquer fio de cobre exposto a sair do terminal. Qualquer fio exposto pode conduzir níveis perigosos de electricidade para a pessoa que toque nos fios.



**Nota:** Este sistema funciona com sistemas CC com ligações à terra Positivas ou Negativas.

## Seguridad

---



**ADVERTENCIA:** en un entorno doméstico, este producto puede causar radiointerferencias, en cuyo caso, puede requerirse del usuario que tome las medidas que sean convenientes al respecto.



¡**ADVERTENCIA!** Producto láser Clase I.



¡**ADVERTENCIA!** No mirat fijamente el haz.



### AVISOS ELECTRICOS

#### **ADVERTENCIA:** PELIGRO DE ELECTROCHOQUE

Para evitar un ELECTROCHOQUE, no quite la tapa. No hay ningún componente en el interior al cual puede prestar servicio el usuario. Esta unidad contiene VOLTAJES PELIGROSOS y sólo deberá abrirla un técnico entrenado y calificado.



#### **PELIGRO DE RAYOS**

**PELIGRO:** NO REALICE NINGUN TIPO DE TRABAJO O CONEXION en los equipos o en LOS CABLES durante TORMENTAS ELECTRICAS.



**ATENCION:** EL CABLE DE ALIMENTACION SE USA COMO UN DISPOSITIVO DE DESCONEXION. PARA DESACTIVAR EL EQUIPO, desconecte el cable de alimentación.



ELECTRICO - EQUIPO DEL TIPO CLASE I

ESTE EQUIPO TIENE QUE TENER CONEXION A TIERRA. El cable tiene que conectarse a un enchufe a tierra debidamente instalado. Un enchufe que no está correctamente instalado podría ocasionar tensiones peligrosas en las partes metálicas que están expuestas.



EQUIPO CONECTABLE, el tomacorriente se debe instalar cerca del equipo, en un lugar con acceso fácil”.



**ATENCION:** Las aberturas para ventilación no deberán bloquearse y deberán tener acceso libre al aire ambiental de la sala para su enfriamiento.



**TEMPERATURA REQUERIDA PARA LA OPERACIÓN:** AT-8900/

AT-9900 producto está diseñado para una temperatura ambiental máxima de 50 grados C. AT-9900s producto está diseñado para una temperatura ambiental máxima de 40 grados C.



**ELECTRICO - SOBRECARGA DEL CIRCUITO PRIMARIO DE CORRIENTE ALTERNA**

Al instalarse el producto deberán considerarse las potencias nominales acumulativas, cuando se conecta el equipo al cable de alimentación de corriente alterna.



**ATENCIÓN:** CARGA MECANICA - El montaje del equipo en el bastidor debe realizarse de manera tal que no cause una condición peligrosa debido a la distribución desigual del peso.



Batería de litio - Sólo deberá ser cambiada por un técnico entrenado y calificado.  
**ATENCIÓN:** Peligro de explosión si la batería no se reemplaza en forma correcta. Reemplace sólo con el mismo tipo o equivalente que recomienda el fabricante. Deseche las baterías usadas según las instrucciones del fabricante.



**PARA TODOS LOS PAÍSES:** Monte el producto de acuerdo con los Códigos Eléctricos locales y nacionales.



**Advertencia:** PARA HACER CONEXIONES DE CC CENTRALIZADAS, INSTALE EL CONMUTADOR ÚNICAMENTE EN LUGARES CON ACCESO RESTRINGIDO.



**Nota:** Para conectar la fuente de alimentación, se necesita un cable de bastidor si el aparato es activado por una fuente de alimentación de CC. El cable de bastidor debe figurar en la lista de UL, ser de tipo TC, tener una clasificación de 600 V y 90 grados C, y disponer de tres conductores con un mínimo de 12 según el Patrón de Medidas Estadounidense (AWG - American Wire Gage).



**Advertencia:** ÚNICAMENTE EMPLEADOS CAPACITADOS Y COMPETENTES TIENEN LA AUTORIZACIÓN DE INSTALAR O REPONER DICHO EQUIPO.



**Advertencia:** Por razones de precaución, se debe instalar un cortacircuitos de 15 amperios en el extremo de alimentación del cable que se utilizará con este equipo LAN.

**SIEMPRE** conecte los cables al equipo LAN primero, antes de conectarlos al cortacircuitos. Para evitar el peligro de sufrir daños corporales a causa de sacudidas eléctricas, no trabaje con conductores CON CORRIENTE. Asegúrese siempre de que el cortacircuitos esté en la posición de APAGADO (OFF) antes de conectar los cables al cortacircuitos.



**Advertencia:** No pele el cable más de la cantidad recomendada, ya que si después de instalar el bloque terminal quedan cables pelados, habrá riesgos de seguridad.



**Advertencia:** Cuando instale dicho equipo, asegúrese siempre de que el bastidor se conecte a tierra primero y se desconecte por último.



**Advertencia: “Riesgo de seguridad”** Cerciórese de que no haya hilos de cobre pelados que salgan del alambre instalado. Cuando dicha instalación se realiza correctamente, los hilos de cobre pelados no deben salir del bloque terminal. Todo alambre pelado puede conducir niveles de electricidad nocivos a la persona que lo toca.



**Nota:** Este sistema funcionará con sistemas de CC con conexión positiva o negativa a tierra.

## Säkerhet

---



**WARNING:** Denna produkt kan ge upphov till radiostörningar i hemmet, vilket kan tvinga användaren till att vidtaga erforderliga åtgärder.



**WARNING!** Laserprodukt av klass I.



**WARNING!** Laserstrålning när enheten är öppen.



**TILLKÄNNAGIVANDEN BETRÄFFANDE ELEKTRICITETSRIK:**  
RISK FÖR ELEKTRISK STÖTFör att undvika ELEKTRISK stöt, ta ej av locket. Det finns inga delar inuti som behöver underhållas. Denna apparat är under HÖGSPÄNNING och får endast öppnas av en utbildad kvalificerad tekniker.



### **FARA FÖR BLIXTNEDSLAG**

**FARA:** ARBETA EJ på utrustningen eller kablarna vid ÅSKVÄDER.



**WARNING:** NÄTKABELN ANVÄNDS SOM STRÖMBRYTARE FÖR ATT KOPPLA FRÅN STRÖMMEN, dra ur nätkabeln.



ELEKTRISKT - TYP KLASS I UTRUSTNING  
DENNA UTRUSTNING MÅSTE VARA JORDAD. Nätkabeln måste vara ansluten till ett ordentligt jordat uttag. Ett felaktigt uttag kan göra att närliggande metalldelar utsätts för högspänning. Apparaten skall anslutas till jordat uttag, när den ansluts till ett nätverk.



UTRUSTNING MED PLUGG. Uttaget skall installeras i utrustningens närhet och vara lättåtkomligt”.



**WARNING:** Luftventilerna får ej blockeras och måste ha fri tillgång till omgivande rumsluft för avsvälning.



**DRIFTSTEMPERATUR:** AT-8900/AT-9900 produkt är konstruerad för rumstemperatur ej överstigande 50 grader C. AT-9900s produkt är konstruerad för rumstemperatur ej överstigande 40 grader C.



ELEKTRISKT - ÖVERBELASTNING AV VÄXELSTRÖMSNÄTET: När produkten installeras bör den sammanlagda effekten på namnplåten beaktas när apparaten ansluts till växelströmsnätet.



**WARNING: MEKANISK BELASTNING:** Utrustningen ska installeras i chassit på så sätt att fara inte uppstår p g a ojämn belastning.



Litium batteri - Får endast bytas av utbildade och kvalificerade tekniker.

**WARNING:** Risk för explosion om felaktigt batteri används. Byt endast mot samma eller likvärdig typ batteri, rekommenderat av tillverkaren. Kassera använda batterier i enlighet med tillverkarens instruktioner.



**ALLA LÄNDER:** Installera produkten i enlighet med lokala och statliga bestämmelser för elektrisk utrustning.



**Warning:** ANSLUTNING TILL LIKSTRÖMSNÄT FÅR ENDAST SKE I LOKAL DÄR OBEHÖRIGA EJ ÄGER TILLTRÄDE.



**Anmärkning:** Kanalkabel krävs för att ansluta strömkällan om enheten ansluts till likströmsnät. Kanalkabeln måste vara UL-märkt och av TC-typ. Kabeln måste ha en märkspänning på 600 V och en märktemperatur på 90 grader C samt ha tre ledare med en tjocklek på minst 12 AWG (amerikanskt ledningsmått).



**Warning:** INSTALLATION OCH UTBYTE AV DENNA UTRUSTNING FÅR ENDAST UTFÖRAS AV AUKTORISERAD ELINSTALLATÖR.



**Warning:** Av säkerhetsskäl skall en 15 A automatsäkring anslutas till försörjningsänden på kabeln som används till denna LAN-utrustning.

Ledningar skall **ALLTID** anslutas till LAN-utrustningen innan ledningarna ansluts till automatsäkringen. För att förebygga uppkomsten av personskador orsakade av elektrisk stöt skall man inte vidröra strömförande uttag. Kontrollera alltid att automatsäkringen är i läget OFF (AV) innan anslutning av ledningar till automatsäkringen sker.



**Warning:** Skala inte av mer isolering än vad som anges ovan. Skalas för mycket isolering av kan fara uppstå om oskyddad tråd vidrörs på anslutningsplinten efter anslutningen.



**Warning:** Vid anslutning av denna utrustning skall man alltid se till att jordtråden ansluts först och lossas sist.



**Warning: OBS! FARA!** Kontrollera om små koppartrådar sticker ut ifrån den anslutna tråden. Om anslutningen utförts riktigt sticker inga trådar ut från anslutningsplinten. Oisolerade trådar kan överföra skadlig elektricitet till person som vidrör trådarna.



**Anmärkning:** Detta system fungerar både med positivt och negativt jordade likströmskällor.

## EC Declaration of Conformity

---

We: **ALLIED TELESYN RESEARCH LIMITED**  
**27 NAZARETH AVENUE**  
**CHRISTCHURCH 8002**  
**NEW ZEALAND**

Declare under our sole legal responsibility that the following product meets the safety, protection and conformity requirements of council directives 73/23/EEC and 89/336/EEC, as amended by 93/68/EEC, on the approximation of the laws of member states relating to electromagnetic compatibility, electrical safety and the mutual recognition of conformity of telecommunications terminal equipment

### **AT-8900, AT-9900, AT-9900s SERIES SWITCHES**

to which this declaration relates are in conformity with the following relevant harmonized standards, the reference numbers of which have been published in the Official journal of the European community.

- EN55022: 1998 Information Technology Equipment—Radio disturbance
- EN55024: 1998 Information Technology Equipment—Immunity characteristics—Limits and methods of measurement.
- EN60950: 2000 Safety of Information Technology Equipment, including electrical business equipment. (for AT-8900 only)
- EN60950-1: 2001 Information Technology Equipment including electrical business equipment—General Requirements.
- EN60825-1: 1994 Safety of Laser Products - part 1: Equipment classification, requirements and user's guide.
- EN61000-3-2: 2000 Electromagnetic compatibility (EMC) - part 3-2: Limits for harmonic current emissions (equipment input current up to and including 16A per phase).
- EN61000-3-3: 1995 Electromagnetic compatibility (EMC) - part 3-3: Limitation of voltage fluctuations and flicker in low-voltage supply systems for equipment with rated current up to 16A.

Name: Craig Thornton

Position: Engineering Manager

On behalf of the Manufacturer

Signature

Date: 11th August 2004

:



## Free Manuals Download Website

<http://myh66.com>

<http://usermanuals.us>

<http://www.somanuals.com>

<http://www.4manuals.cc>

<http://www.manual-lib.com>

<http://www.404manual.com>

<http://www.luxmanual.com>

<http://aubethermostatmanual.com>

Golf course search by state

<http://golfingnear.com>

Email search by domain

<http://emailbydomain.com>

Auto manuals search

<http://auto.somanuals.com>

TV manuals search

<http://tv.somanuals.com>