



AT-FH812u

AT-FH824u

AT-FH812u-SW

AT-FH824u-SW

Fast Ethernet 10/100 Hubs

Version 2

Installation Guide

Copyright © 2000 Allied Telesyn International, Corp.
960 Stewart Drive Suite B, Sunnyvale CA 94085 USA

All rights reserved. No part of this publication may be reproduced without prior written permission from Allied Telesyn International, Corp.

Ethernet is a registered trademark of Xerox Corporation. All other product names, company names, logos or other designations mentioned herein are trademarks or registered trademarks of their respective owners.

Allied Telesyn International, Corp. reserves the right to make changes in specifications and other information contained in this document without prior written notice. The information provided herein is subject to change without notice. In no event shall Allied Telesyn International, Corp. be liable for any incidental, special, indirect, or consequential damages whatsoever, including but not limited to lost profits, arising out of or related to this manual or the information contained herein, even if Allied Telesyn International, Corp. has been advised of, known, or should have known, the possibility of such damages.

Agency Compliance

EMI Certification

FCC Class A (USA)

Warning: This equipment generates, uses, and can radiate radio frequency energy and, if not installed and used in accordance with the instruction manual, may cause interference to radio communications. It has been tested and found to comply with the limits for a Class A digital device pursuant to Subpart B of Part 15 of FCC Rules, which are designed to provide reasonable protection against such interference when operated in a commercial environment. Operation of this equipment in a residential area is likely to cause interference, in which case the user, at his own expense, will be required to take whatever measures are required to correct the interference.

You may use shielded (STP) or unshielded twisted-pair (UTP) for RJ-45 connections - Category 3 or greater for 10 Mbps connections, and Category 5 for 100 Mbps connections.

Industry Canada Class A

This Class A digital apparatus meets all requirements of the Canadian Interference-Causing Equipment Regulations.

Cet appareil numérique de la classe A respecte toutes les exigences du Règlement sur le matériel brouilleur du Canada.

European EMC Compliance

CE Mark Declaration of Conformance for EMI and Safety (EEC)

This is to certify that this product complies with ISO/IEC Guide 22 and EN45014.

It conforms to the following specifications:

- Emissions: EN55022 (1988)/CISPR-22 (1985) class A
- Immunity: EN50082-1
- EN60555-2 (1995) class A
- EN60555-3



Warning

Do not plug a phone jack connector in the RJ-45 port. This may damage this device.

Safety Compliance



Warning

Before making connections, make sure you have the correct Cord Set. Check it (read the label on the cable) against the following specification list.

Voltage	Cord Set Specifications
120 Volts	UL Listed/CSA Certified Cord Set
	Minimum 18 AWG; type SVT or SJT three conductor cord
	Maximum length of 15 feet
	Parallel blade, grounding type attachment plug rated 15A, 125V
240 Volts (North America)	UL Listed/CSA Certified Cord Set
	Minimum 18 AWG; type SVT or SJT three conductor cord
	Maximum length of 15 feet
230 Volts (Europe only)	Cord Set with H05VV-F cord having three conductors with minimum diameter of 0.75 mm ²
	IEC-320 receptacle; male plug rated 10A, 250V

Table of Contents

Agency Compliance	iii
Welcome to Allied Telesyn	vii
Where to Find Web-based Guides	vii
Documentation Conventions	vii
Contacting Allied Telesyn.....	viii
Online Support.....	viii
Technical Support Telephone and Fax Numbers.....	viii
Technical Support E-mail Addresses.....	viii
Returning Products.....	ix
FTP Server	ix
For Sales or Corporate Information.....	ix
Tell Us What You Think.....	ix
Chapter 1	
Introduction	1
Chapter 2	
Installation	3
Package Contents	3
Pre-Installation Requirements	3
Stacking Hubs on a Flat Surface	4
Rack-Mounting the Hubs	4
Connecting the Hub System.....	4
Making a Connection via an MDI-X Station Port.....	5
Connecting to the Stack's Backplane.....	5
Making a Connection via the MDI Daisy-Chain Port.....	6
Using an Optional Module	9
Installing an Optional Module	9
Using the Agent Module (AT-FH805u).....	10
Using the Switch Module (AT-FH806u)	10
Using the 100Base-FX Module (AT-FH807u)	11
Using the 100Base-TX Module (AT-FH808u)	11
Powering ON the Hub	12
Verifying Port Status.....	13
Verifying System Operation.....	14

Chapter 3

Troubleshooting 15

- Diagnosing Hub LEDs 15
- Power and Cooling Problems..... 15
- Installation Verification 16
- Cabling Verification 16
- Network Adapter Verification..... 16
- RJ-45 Port and Cable Assignments 16

Appendix A

Technical Specifications 19

Product Specifications..... 19

- Base Unit 19
- Network Criteria..... 20
- AT-FH805u Agent Module 20
- AT-FH806u Switch Module..... 21
- AT-FH807u Uplink Module..... 21
- AT-FH808u Uplink Module..... 21

Appendix B

Technical Support Fax Order 23

Incident Summary 23

Appendix C

AT-FH800 Series Installation Guide Feedback 25

Welcome to Allied Telesyn

This guide contains instructions on how to install and configure a AT-FH800 Series Fast Ethernet Hub.

Where to Find Web-based Guides

The Allied Telesyn web site at www.alliedtelesyn.com provides you with an easy way to access the most recent documentation and technical information for all of our products. For product guides, you can go directly to the following web page: www.alliedtelesyn.com/support/prd_libs.htm.

Document Conventions

Through out this guide, you will notice several conventions that you should become familiar with first before installing the product.

Note

A note provides additional information.



Caution

A caution indicates that performing or omitting a specific action may result in equipment damage or loss of data.



Warning

A warning indicates that performing or omitting a specific action may result in bodily injury.

Contacting Allied Telesyn Technical Support

There are several ways to contact Allied Telesyn technical support: online, telephone, fax or e-mail.

Online Support

You can request technical support online by filling out the Online Technical Support Form at www.alliedtelesyn.com/forms/support.htm.

Telephone and Fax Support

For Technical Support via fax, please fill out the "Technical Support Fax Order" on page 23 and send it to the appropriate location listed below.

Americas

United States, Canada, Mexico,
Central America, South America
Tel: 1 (800) 428-4835, option 4
Fax: 1 (503) 639-3176

Asia

Singapore, Taiwan, Thailand, Malaysia,
Indonesia, Korea, Philippines, China,
India, Hong Kong
Tel: (+65) 381-5612
Fax: (+65) 383-3830

Australia

Tel: 1 (800) 000-880
Fax: (+61) 2-9438-4966

France

France, Belgium, Luxembourg,
The Netherlands, Middle East, Africa
Tel: (+33) 0-1-60-92-15-25
Fax: (+33) 0-1-69-28-37-49

United States and Canada

Ts1@alliedtelesyn.com

Latin America, Mexico, Puerto Rico, Caribbean, and Virgin Islands

latin_america@alliedtelesyn.com

United Kingdom, Sweden, Norway, Denmark, and Finland

support_europe@alliedtelesyn.com

Germany

Germany, Switzerland, Austria, Eastern
Europe
Tel: (+49) 0130/83-56-66
Fax: (+49) 30-435-900-115

Italy

Italy, Spain, Portugal, Greece, Turkey,
Israel
Tel: (+39) 02-416047
Fax: (+39) 02-419282

Japan

Tel: (+81) 3-3443-5640
Fax: (+81) 3-3443-2443

United Kingdom

United Kingdom, Denmark, Norway,
Sweden, Finland
Tel: (+0044) 1235-442500
Fax: (+44) 1-235-442680

E-mail Support

Returning Products

Products for return or repair must first be assigned a Return Materials Authorization (RMA) number. A product sent to Allied Telesyn without a RMA number will be returned to the sender at the sender's expense.

To obtain an RMA number contact Allied Telesyn's Technical Support at one of the following locations:

North America

2205 Ringwood Ave
San Jose, CA 95131
Tel: 1-800-428-4835, option 4
Fax: 1-503-639-3716

European Customer Support Centre

10/11 Bridgemoor Close
Westmead Industrial Estate
Swindon, Wiltshire SN5 7YT
England
Tel: +44-1793-501401
Fax: +44-1793-431099

Latin America, the Caribbean, Virgin Islands

Tel: international code + 425-481-3852
Fax: international code + 425-483-9458

Mexico and Puerto Rico

Tel: 1-800-424-5012, ext 3852 or
1-800-424-4284, ext 3852
Mexico only: 95-800-424-5012, ext 3852
Fax: international code + 425-489-9191

FTP Server

If you know the name of a specific driver that you need for an Allied Telesyn device, you can download the software by connecting directly to our FTP server at:
<ftp://gateway.centre.com>.

At login, enter 'anonymous'. Enter your e-mail address for the password as requested by the server at login.

For Sales or Corporate Information

Allied Telesyn International, Corp.
19800 North Creek Parkway, Suite 200
Bothell, WA 98011
Tel: 1 (425) 487-8880
Fax: 1 (425) 489-9191

Allied Telesyn International, Corp.
960 Stewart Drive, Suite B
Sunnyvale, CA 94085
Tel: 1 (800) 424-4284 (USA and Canada)
Fax: 1 (408) 736-0100

Tell Us What You Think

If you have any comments or suggestions on how we might improve this or other Allied Telesyn documents, you can fill out the "AT-FH800 Series Installation Guide Feedback" on page 25 and return the form to us at the address or fax number provide. You can provide feedback online by filling out the Send Us Feedback Form at **www.alliedtelesyn.com/forms/feedback.htm**.

Chapter 1

Introduction

The AT-FH800 Series Fast Ethernet Hubs include the following models:

- ❑ AT-FH812u
- ❑ AT-FH812u-SW
- ❑ AT-FH824u
- ❑ AT-FH824u-SW

The AT-FH812u (shown in Figure 1) and AT-FH824u are manageable and stackable Ethernet hubs with 12 or 24 dual-speed (RJ-45) ports. One slot is used for an Optional Agent Module, and another slot for an Optional Switch Module. The 12 and 24 port AT-FH812u-SW and AT-FH824u-SW are base unit with optional switch modules installed. The AT-FH800-SW models are available in North America only.

These dual-speed hubs provide the easiest method to upgrade your network to fast Ethernet. It is not necessary to replace your existing network infrastructure. Just add an Allied Telesyn dual-speed hub to your network and attach any 10 or 100 Mbps device to any port on the hubs. These hubs provide both the standard 10 Mbps bandwidth needed for common file transfers, and a larger channel with 100 Mbps of bandwidth that is essential for relieving serious network congestion, running multimedia applications, or satisfying power users.

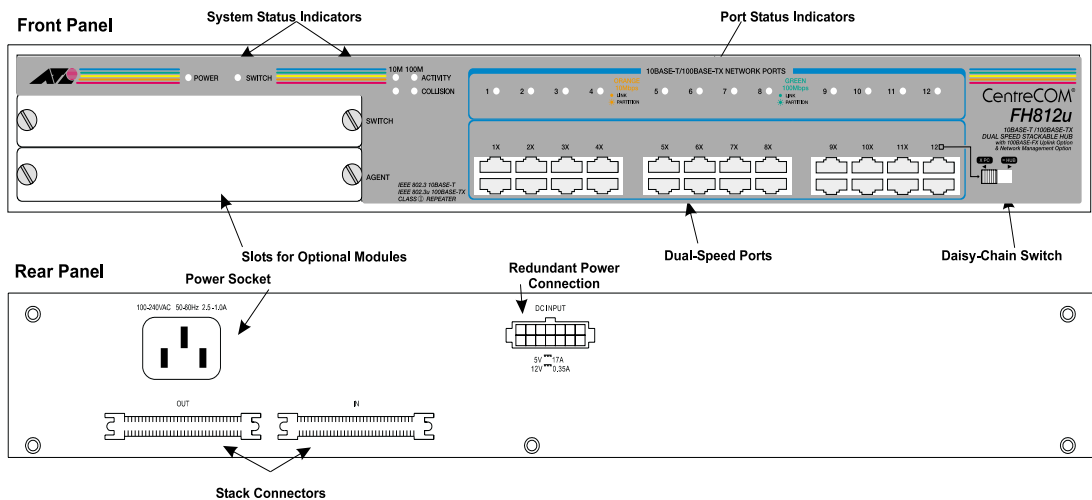

Figure 1 AT-FH812u Hub Front and Rear Panels

These dual-speed hubs include a wide range of configuration options. They can be stacked together (up to 6 high) to form a dual-speed network of up to 72/144 ports. With a Class II rating, they can also be easily cascaded to additional 10 or 100 Mbps hubs. When the switch module is installed, it links the hub's internal 10 Mbps and 100 Mbps repeater buses together to form a segmented network, allowing traffic to pass between the segments when required.

Moreover, the optional Agent Module provides the broadest range of management options possible. It provides support for SNMP and the following RMON groups: statistic, history, alarm and event. Web management, and remote access via an in-band, Telnet or SLIP connection.

These hubs consist of 12/24 RJ-45 dual-speed (10/100 Mbps) ports, and two slots on the front panel for optional slide-in modules, including switch modules for internal segment interconnection or external media expansion (using cable or fiber optics), and an Agent Module.

Chapter 2

Installation

Verifying Package Contents

Make sure your package contains the following items.

- One AT-FH800 Series Fast Ethernet Hub
- Four rubber foot pads
- Stack cable
- Rack mount bracket kit
- AC power cord
- This installation guide
- Warranty card

Pre-Installation Requirements

Prior to installing your hub, make sure you observe the following cabling and installation environment requirements. The hub can be placed directly on your desktop or mounted in a rack.

- Do not plug a phone jack connector into any RJ-45 port. This may damage the hub. Use only twisted-pair cables with RJ-45 connectors that conform with FCC standards.
- Make sure each twisted-pair cable does not exceed 100 meters (328 feet).
- Allied Telesyn recommends using Category 5 cable for all network connections to avoid any confusion or inconvenience in the future when you upgrade attached devices to Fast Ethernet.
- Power requirements: 100 to 240 VAC \pm 10% at 50 to 60 Hz \pm 3Hz. The hub's power supply automatically adjusts to the input voltage level.
- The hub should be located in a cool, dry place, with at least 10 centimeters (4 inches) of space at the front and back for ventilation.
- Place the hub out of direct sunlight, and away from heat sources or areas with a high amount of electromagnetic interference.
- If you intend to mount the hub in a rack, make sure you have all the necessary mounting screws, brackets, bolts and nuts, and the right tools.
- Check if network cables and connectors needed for installation are available.

Stacking Hubs on a Flat Surface

The hub can be stacked on a secure table or desktop.

1. Attach the self-adhesive rubber foot pads (that come with this package) on each of the 4 concave spaces located on the bottom of the first hub.
2. Place the first hub on a firm flat surface where you want to install the stack.
3. Repeat Step 1 for each hub before stacking them. The rubber foot pads cushion the hub against shock/vibrations and provide space between each hub for ventilation.

Rack-Mounting the Hubs

Please comply with the following instructions to ensure that your hub is securely mounted in the rack, as shown in Figure 2.

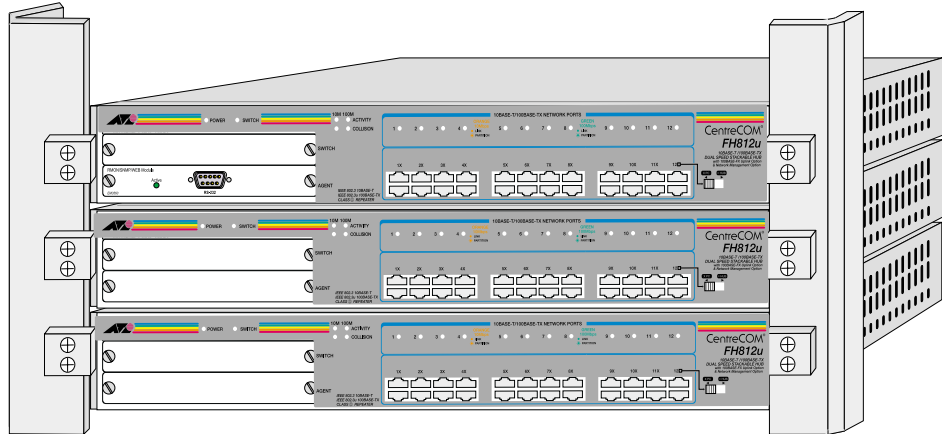

Figure 2 Rack-Mounting Hubs

1. Use a standard EIA 19-inch rack.
2. Use the brackets and screws supplied in the rack mounting kit.
3. Use a cross-head screwdriver to attach the brackets to the side of the hub.
4. Position the hub in the rack by lining up the holes in the brackets with the appropriate holes on the rack, and then use the supplied screws to mount the hub in the rack.

Connecting the Hub System

The hub has 12/24 RJ-45 ports, one of which also serves as a dual-speed (MDI/MDI-X) daisy-chain port. All the repeater ports support 10 or 100 Mbps half-duplex connections.

Making a Connection via an MDI-X Station Port

You can connect any RJ-45 (MDI-X) station port on the hub to any device that uses a standard network interface such as a PC or server, or to a network interconnection device such as a bridge or router (depending on the port type implemented).

1. Prepare the network devices you wish to network. Make sure you have installed 10Base-T or 100Base-TX network interface cards for connecting to the hub's RJ-45 (MDI-X) station ports. You also need to prepare straight-through shielded or unshielded twisted-pair cables with RJ-45 connector at both ends. Use 100 Ohm Category 3, 4 or 5 cable for standard 10 Mbps Ethernet connections, or 100 Ohm Category 5 cable for 100 Mbps Fast Ethernet connections.
2. Connect one end of the cable to the RJ-45 port of the network interface card, and the other end to any available (MDI-X) station port on the hub. When inserting an RJ-45 plug, be sure the tab on the plug clicks into position to ensure that it is properly seated. Using the hub in a stand-alone configuration, you can network up to 12/24 end nodes.

Connecting to the Stack's Backplane

As shown in Figure 3:

1. Plug one end of the stack cable (provided with the package) in the "Out" port of the top hub and the other end to the "IN" port of the next hub.
2. Repeat this step for each hub in the stack. Form a simple chain starting at the Out port on the first hub and ending at the IN port on the last hub (stacking up to 6 hubs).

Note

All the hubs must be powered ON to allow traffic to pass through the stack.

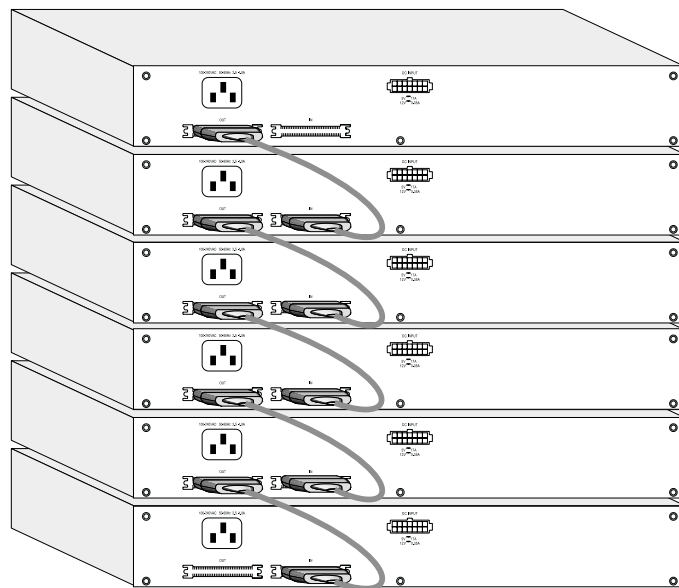

Figure 3 Connecting to the Backplane

Making a Connection via the MDI Daisy-Chain Port

1. To make a direct connection to a compatible hub or switch, use the MDI daisy-chain port (Port 12/24). When connecting to this port, remember to set the port selection switch to MDI. You can also connect any RJ-45 (MDI-X) port on the hub to an MDI daisy-chain port on the other device.
2. Prepare straight-through shielded or unshielded twisted-pair cables with RJ-45 plugs at both ends. Use 100 Ohm Category 3, 4 or 5 cable for standard 10 Mbps Ethernet connections, or 100 Ohm Category 5 cable for 100 Mbps Fast Ethernet connections. When inserting an RJ-45 plug, be sure the tab on the plug clicks into position to ensure that it is properly seated.

Note

To connect to another hub or switch, you may also attach to (MDI-X) station ports at both ends if you use crossover cabling. For additional information, see “Cabling Verification” on page 16.

3. When connecting to another hub running at 10 Mbps, you can cascade up to 4 hubs, and use up to 100 meters (328 feet) for each inter-hub link. However, if you cascade to another hub running at 100 Mbps (such as two dual-speed hubs), you can only cascade two hubs, and the inter-hub cabling must be limited to 5 meters (16 feet). Configuration examples of dual-speed hubs with switch for both the 10Base-T (Figure 4) and 100Base-TX (Figure 5) cascade rule each include two workable cascade configurations and one example of a configuration that will not work (does not cascade correctly).
4. The only way to extend the inter-hub cabling when operating at 100 Mbps is to reduce the length of cable used to connect the PCs to the hubs. To achieve a larger network diameter, you should use a switch to connect several hubs (or stacks) together. Because a switch breaks up the path for connected devices into separate collision domains, it has no restrictions on cascade length.

10Base-T Cascade Rule
A maximum of four hubs/repeaters can be cascaded
within the same 10Base-T collision domain

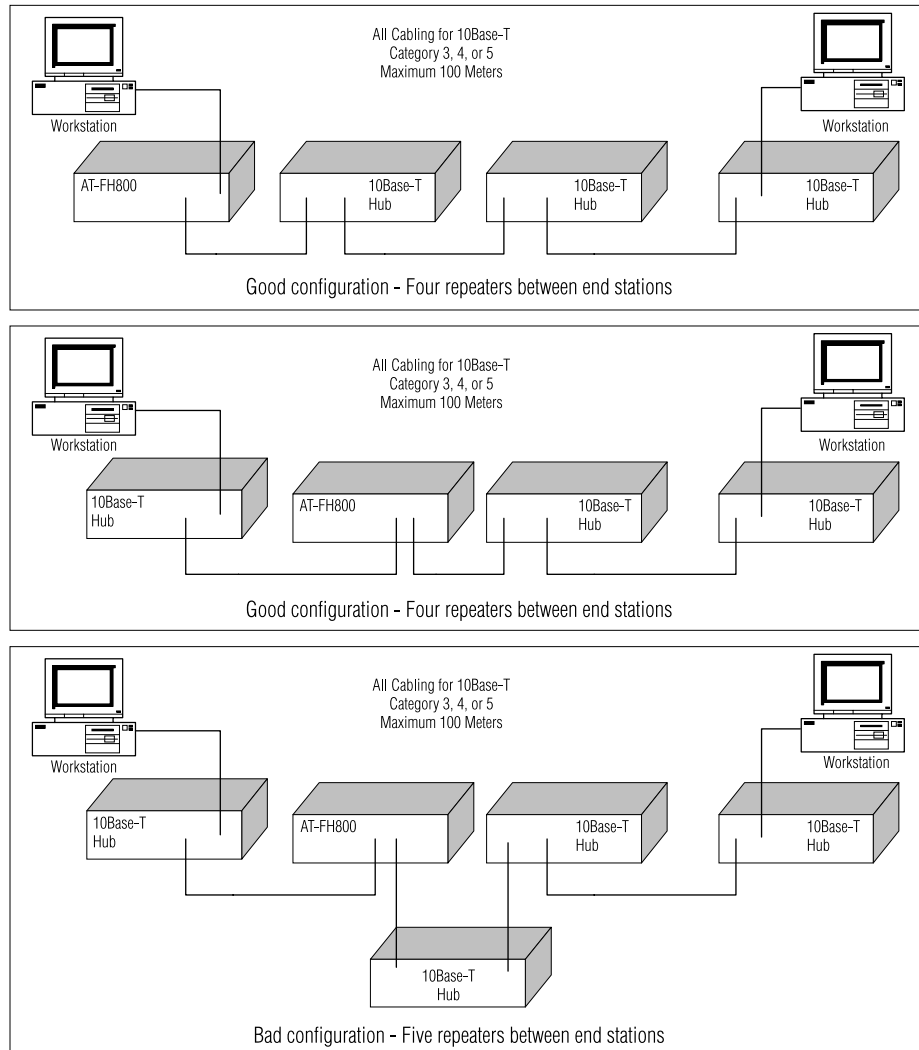

Figure 4 10Base-T Cascade Configuration

10Base-T Cascade Rule
A maximum of four hubs/repeaters can be cascaded
within the same 10Base-T collision domain

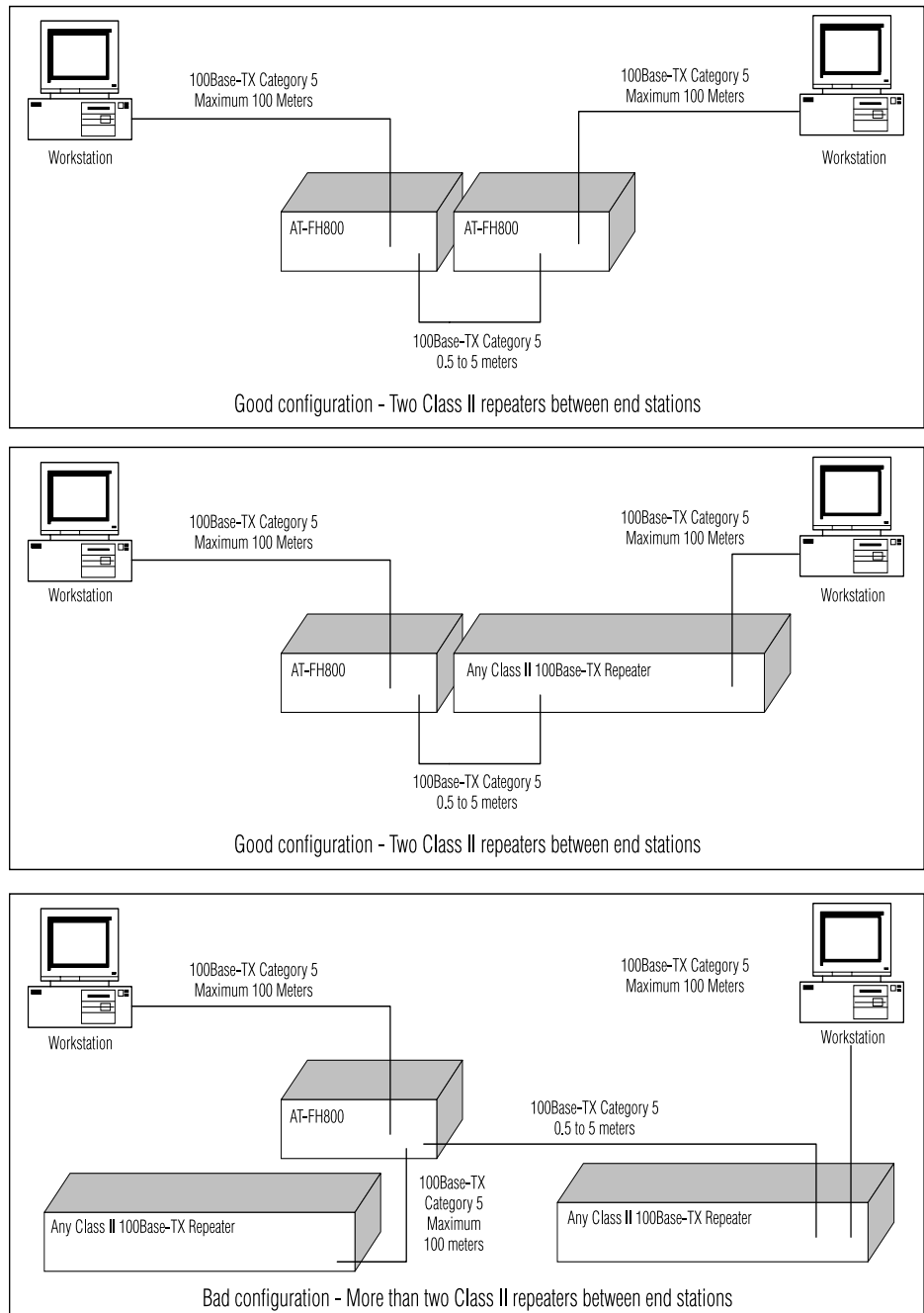

Figure 5 100Base-TX Cascade Configuration

Using an Optional Module

The upper slot on the front of the hub is provided for installing anyone of the 3 different Switch Modules or Media Expansion Modules (also referred to as an uplink module). The Switch Module is used to bridge the internal 10 and 100 Mbps repeater buses, the twisted-pair and fiber optic uplink modules are used to link the stack to other segments or to a remote site.

Note

The Media Expansion Modules confine local traffic to the stack, passing traffic to the attached device only when required.

The lower slot on the front panel is used for installing an Agent Module, which provides management access to the hub or the connected stack using a direct console or modem connection via Telnet, a web browser, or SNMP/RMON management software.

Installing an Optional Module

To install an optional module, do the following:

1. Disconnect power to the hub.
2. Remove the face plate (or a previously installed module) from the appropriate slot by removing the two screws with a cross-head screwdriver. A Switch Module or uplink module can be installed in the upper slot on the front of the hub, and the Agent Module can be installed in the lower slot on the front of the hub.
3. Before opening the package that contains the uplink module, touch the bag to the hub casing to discharge any potential static electricity.
4. Remove the module from the anti-static shielded bag.
5. Holding the module level, gently push it all the way into the expansion slot, ensuring that it firmly engages with the connector.
6. If you are sure the module is properly mated with the connector, replace the retainer screws to secure the module in the expansion slot.
7. Run corresponding media type between the uplink module and the target device.

Note

Uplink modules are not hot-swappable. Be sure you power OFF the switch before installing any of these modules.

Using the Agent Module (AT-FH805u)

To manage the hub (or stack), you must install an optional Agent Module, AT-FH805u, in the lower slot on the front of the hub (See Figure 6). Once you have installed the module, you will be able to manage the system via a direct connection to the serial port on the front of the module (using a console or modem connection). The management agent provided with this module can also be accessed over the network using Telnet for a text-based interface, with a web browser for a graphic interface, or using network management software based on SNMP/RMON protocols from a management station anywhere in the network. See the *AT-FH812u and AT-FH824u User's Guide* for further information. This guide can be downloaded from Allied Telesyn's website at www.alliedtelesyn.com/support/prd_libs.htm.

Note

The Agent Module is not hot-swappable. Be sure you power OFF the hub before installing any of these modules.

Note

Do not install more than one Agent Module in a stack.

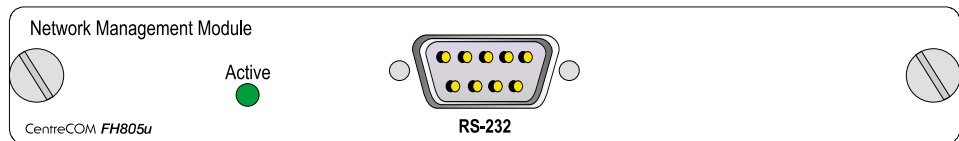

Figure 6 Agent Module Front Panel

Using the Switch Module (AT-FH806u)

The 10 and 100 Mbps repeater buses in the hub can be linked together by installing an optional switch module (AT-FH806u) in the upper slot on the front panel (See Figure 7). The switch module is used when traffic must be passed to a destination in the other segment, when broadcast traffic is sent, or when the destination is unknown.

Note

AT-FH812u-SW and AT-FH824u-SW have the switching module already installed.

Note

Multiple switch modules may be installed in a stack, but only one of the modules will actively bridge the 10 and 100 Mbps repeater buses. The other modules will be placed in standby mode, and will only be enabled if the primary switch module should fail or is powered OFF.

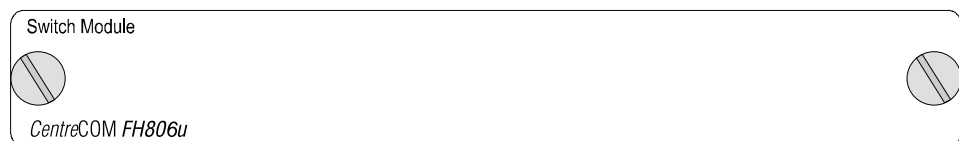

Figure 7 Switch Module Front Panel

Using the 100Base-FX Module (AT-FH807u)

You can connect to a remote site using the fiber optic uplink module AT-FH807u. These modules act as a two-port switch, interfacing the internal repeater buses to the attached device. SC fiber module is available. It connects to both the internal 10 and 100 Mbps repeater bus, but operates only at 100 Mbps for the external connection. The default setting of this module is auto-negotiate (see Figure 8).

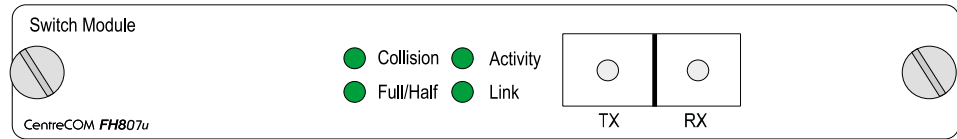

Figure 8 100Base-FX Module Front Panel

Before using a fiber optic module, prepare fiber optic cable connectors at both ends. When connecting the module directly to an end-node device, for example a workstation or file server, run cable from the RX (TX) port on the module to the TX (RX) port on the target device. When inserting the cable, be sure the tab on the plug clicks into position to ensure that it is properly seated. Note that as a general rule, the length of fiber optic cable should not exceed 2 kilometers (1.24 miles) when the link is operated at full-duplex or 412 meters (0.25 miles) for half-duplex.

Note

In the present design, the uplink port only can not be monitored or managed by Local Management Agent, Telnet Agent, RMON Agent, SNMP Agent, or Web-based Management.

Using the 100Base-TX Module (AT-FH808u)

You can use a twisted-pair module to connect the stack to a network device in another segment such as another hub, a switch, or a workgroup server. This module acts as a two-port switch, interfacing the internal repeater buses to the attached device. It supports 10 Mbps or 100 Mbps with half- or full-duplex communications via auto-negotiation (if also supported by the attached device). This module confines local traffic to the stack and passes traffic to the attached device only when required.

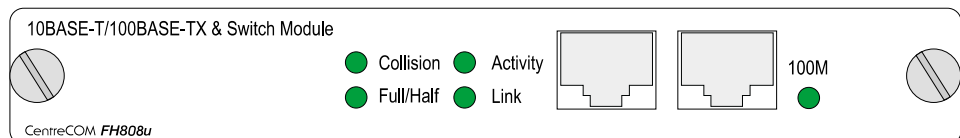

Figure 9 100Base-TX Module Front Panel

Before using the 100Base-TX module, prepare Category 5 straight-through twisted-pair cable with RJ-45 plugs at both ends. When connecting the module directly to an end-node device (e.g., a workstation or file server), a bridge or router, run cable from the MDI-X port on the uplink module to the target device. However, when connecting the module to a compatible hub or switch, connect one end of the cable to the MDI port on the uplink module, and the other end to an MDI-X port on the target device (or vice versa). When inserting an RJ-45 plug, be sure the tab on the plug clicks into position to ensure that it is properly seated. Note that as a general rule, the length of any twisted-pair cable should not exceed 100 meters (328 feet).

Note

In the present design, the uplink port only can not be monitored or managed by Local Management Agent, Telnet Agent, RMON Agent, SNMP Agent, or Web-based Management.

Powering ON the Hub

1. Plug the power cord into the power socket at the rear of the hub, and the other end into a power outlet.
2. Check the LED marked Power ON the front panel to see if it is ON. The unit will automatically select the setting that matches the connected input voltage. Therefore, no additional adjustments are necessary when connecting it to any input voltage within the range marked on the rear panel.
3. The hub performs a self-diagnostic test upon power-on. (Note that this test takes about 10 seconds to complete.)
4. However, remember that the optional slide-in modules are not hot-swappable. Be sure the hub is powered OFF when installing or removing these modules.
5. A socket is provided on the back of the hub for a redundant power unit (RPU) which will supply power to the hub in the event that its internal power supply should fail. Refer to the manual provided with the RPU for further details.

Verifying Port Status

Figure 10 depicts Port LEDs. Check each connection by comparing the port status LEDs with Table 1.

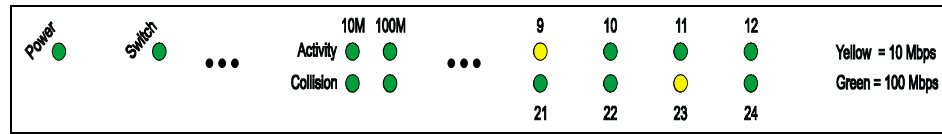

Figure 10 Port LEDs

Table 1 lists and defines the hub's LEDs.

Table 1 LEDs

LED	State	Indication
Power	ON	Hub is receiving power
Switch	OFF	Switch Module is active
	Flashing	Switch Module is not installed or is in slave mode
Segment LEDs (10 Mbps/100 Mbps)		
Activity	Flashing	Traffic exists on the segment
Collision	Flashing	Two or more devices attempted to transmit data at the same time (Normal situation under ethernet CSMA/CD)
Ports LEDs (1-12/24) Yellow = 10 Mbps, Green = 100 Mbps		
Link/Partition	ON	Port has established a valid network connection
	Flashing	Port partitioned due to abnormal network condition
Media Module LEDs		
Full/Half	ON	Port is set to full-duplex
Collision	Flashing	Two or more devices attempted to transmit data at the same time (Normal situation under ethernet CSMA/CD)
Activity	Flashing	Port is passing traffic; blinking proportional to traffic
Link	ON	A valid link has been established on this port
100M	ON	Port is operating at 100 Mbps
Agent Module LEDs		
Active	ON	Agent Module is active
	Flashing	Agent Module is running power-on self-test

Verifying System Operation

Verify that all attached devices have a valid connection. The hub monitors the link status for each port. If any device is properly connected to the hub and transmitting a link beat signal, the Link LED will light up for the corresponding port. If the Link LED fails to light when you connect a device to the hub, check the following items:

- ❑ Be sure all network cables and connectors are properly attached to the connected device and the hub.
- ❑ See if your cable is functioning properly by using it for another port and attached device that displays valid indications when connected to the network.
- ❑ Verify that you have not exceeded the specified limits for cable length. No twisted-pair cable should exceed 100 meters (328 feet). When attaching a 100 Mbps hub to the repeater ports, only one hub can be cascaded and the maximum length of inter-hub cabling is 5 meters (16 feet). Also note that when using fiber optics, you can run a cable up to two kilometers (1.24 miles) when using full-duplex, or up to 412 meters (0.25 miles) with half-duplex.
- ❑ When using an optional uplink module, both sides of the connection must use the same transmission mode (half- or full-duplex). If any device is connected to the 100Base-FX module, then you must manually set the transmission mode using the toggle switch or the configuration options provided by the Agent Module.

Chapter 3

Troubleshooting

Diagnosing Hub LEDs

The hub can be easily monitored through panel LEDs to assist the network manager in identifying problems. This section describes common problems you may encounter and possible solutions.

Symptom. 10/100M Link LED does not light up after making a connection.

Cause. Network interface, for example a network adapter card on the attached device, network cable, or hub port is defective.

Solution. Verify that the hub and attached device are powered on. Be sure the cable is plugged into both the hub and corresponding device. Verify that the proper cable type is used and its length does not exceed specified limits (100 meters/328 feet when connecting to a workstation or switch, and 5 meters/16 feet when connecting to another hub). Check the network adapter on the attached device and cable connections for possible defects. Replace the defective adapter or cable if necessary.

Symptom. Power LED is not green after power-ON.

Cause. Defective power outlet, power cord, or internal power supply.

Solution. Check the power outlet by plugging in another device that is functioning properly. Check the power cord with another device. If these measures fail to resolve the problem, have the unit's power supply replaced by a qualified Allied Telesyn distributor.

Power and Cooling Problems

If the Power LED is not lite when the power is applied, you may have a problem with the power outlet, power cord, or internal power supply as explained in the previous section. However, if the unit powers OFF after running for a while, check for loose power connections, power losses or surges at the power outlet, and verify that the fan on back of the unit is unobstructed and running prior to shutdown. If you still cannot isolate the problem, then the internal power supply may be defective. In this case, contact your Allied Telesyn distributor for assistance.

Installation Verification

Verify that all system components have been properly installed. If one or more components appear to be malfunctioning, for example the power cord or network cabling, test them in an alternate environment where you are sure that all the other components are functioning properly.

Cabling Verification

1. Verify that the cabling type is correct. Be sure all cable connectors are securely seated in the required ports. Use 100 Ohm Category 5 straight-through cable for all standard twisted-pair connections.
2. Make sure all devices are connected to the network. Equipment may have been unintentionally disconnected from the network.
3. This is a Class II hub and can only be cascaded from a repeater port to one other hub using 5 meters (16 feet) of cabling if the link is operating at 100 Mbps. If you must connect to more than one hub, use an optional Media Expansion Module or a switch.
4. If you want to connect to another hub or a switch, use an RJ-45 MDI to MDI-X connection. If you must cascade to a hub or switch using MDI-X ports at both ends of the cable (not the MDI port), make sure a crossover cable is used (see "Making a Connection via an MDI-X Station Port" on page 5). Crossover cable should only be used if an MDI daisy-chain port is not available.

Network Adapter Verification

Make sure the network interface hardware and software drivers for the attached devices are functioning properly. Check the adapter cards and associated drivers used in any attached workstation or server.

RJ-45 Port and Cable Assignments

RJ-45 (MDI-X) station ports (see Figure 11) can be attached to any devices which use a standard network interface (for example, a workstation, server, bridge or router). The RJ-45 (MDI) daisy-chain ports can be cascaded to a station port on similar networking devices (for example, another hub or switch). Use UTP or STP cable for RJ-45 connections: 100 Ohm Category 3, 4 or 5 cable for 10 Mbps connections or 100 Ohm Category 5 cable for 100 Mbps connections. Also be sure that the length of any twisted-pair connection does not exceed 100 meters (328 feet), and that the length of any cascaded connection from a repeater port to another hub does not exceed 5 meters (16 feet) if the link is operating at 100 Mbps.

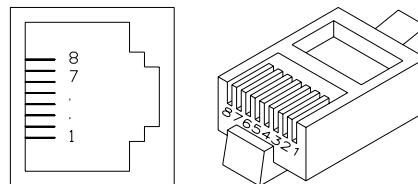
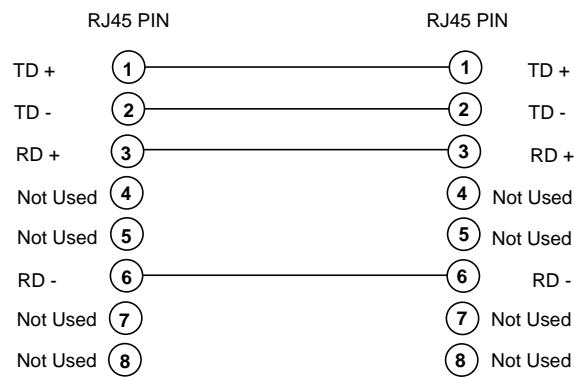

Figure 11 RJ-45 Connector

Port assignments per pin are defined in Table 2, below. Schematics for both straight and crossover twisted-pair cable are shown in Figure 12 and Figure 13.

Table 2 Port Assignments Per Pin

Pin	Assignment (Station ports 1-12/24 MDI-X)	Assignment (Port 12 or 24 MDI)
1	Input Receive Data +	Output Transmit Data +
2	Input Receive Data -	Output Transmit Data -
3	Output Transmit Data +	Input Receive Data +
6	Output Transmit Data -	Input Receive Data -
4, 5, 7, 8	Not Used	Not Used



Per IEEE 802.3 specifications

Figure 12 Schematics for Straight-Through Cable

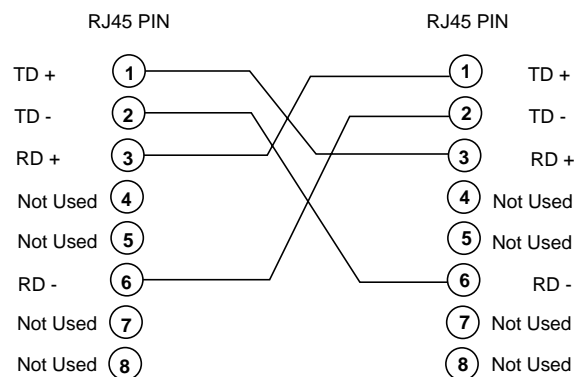

Per IEEE 802.3 specifications

Figure 13 Schematics for Crossover Cable

Appendix A

Technical Specifications

Base Unit

Access Method	CSMA/CD, 10 Mbps or 100 Mbps
Standards Conformance	IEEE 802.3 10Base-T, IEEE 802.3u 100Base-TX
Communication Rate	10 Mbps or 100 Mbps
Media Supported	10Base-T 100 Ohm Category 3,4,5 UTP/STP, 100Base-TX 100 Ohm Category 5 UTP/STP
Number of Ports	12/24 dual-speed ports
Stackable Expansion	Up to 6 modules with stack cable
Indicator Panel	LEDs for monitoring power, switch module, segment activity/collision, port link/partition
Dimensions	440 x 200 x 63 millimeters (17.6 x 8.0 x 2.52 inches)
Weight	4.5 kilograms (9.92 pounds)
Input Power	Full range power input: 100 to 240VAC \pm 10%, 50 to 60 Hz \pm 3Hz, 1.5A
Power Consumption	50 Watts
Heat Dissipation	170.5 BTU/hr
Standard Operating Temperature	0°C to 40°C (32 to 104°C)
Humidity	5% to 95% (Non-condensing)
Certification	CE Mark
Emissions	FCC Class A, VCCI Class A, CISPR Class A, EN55022 Class A
Immunity	EN50082-1
Safety	CSA/NRTL, TUV/GS

Network Criteria¹

Hub-to-Workstation Distance	100 meters maximum using twisted-pair cable
Inter-hub Distance	10 Mbps link: 100 meters using twisted-pair cable 100 Mbps link: 5 meters using twisted-pair cable (assumes 100 meters from each node to the hub)
Total Network Span Single Hub	200 meters of twisted-pair cable (100 meters to each attached node)
Two-hub Chain ¹	205 meters of twisted-pair cable (100 meters to each attached node, and 5 meters between hubs)

1. When cascading a dual-speed hub to another dual-speed hub or to a 100 Mbps hub, the cascade is limited to two hubs, and the interhub cabling is limited to 5 meters. However, up to three 10 Mbps hubs can be cascaded off of a dual-speed hub using 100 meters of cable for each link.

AT-FH805u Agent Module

System Configuration	On-board configuration via console or modem connection to serial port or via Telnet, Web-based management via HTTP protocol to access embedded management program.
Management Agent	SNMP support, MIB II (RFC1213), Multi-segment Repeater MIB (RFC 2108), Ethernet-like MIB (RFC1643), RMON MIB (RFC1757), and Allied Telesyn's private MIB.
RMON	Groups 1-3, 9 (Statistics, History, Alarm, Event).

Pin	Assignment (Station ports 1-24)	Assignment (Daisy Chain Port)
1	Input Receive Data +	Output Transmit Data +
2	Input Receive Data -	Output Transmit Data -
3	Output Transmit Data +	Input Receive Data +
6	Output Transmit Data -	Input Receive Data -
4, 5, 7, 8	Not Used	Not Used

¹ 5 meters = 16 feet, 100 meters = 328 feet,
200 meters = 656 feet, 205 meters = 672 feet

AT-FH806u Switch Module

Network Bridging Function	filtering, forwarding and learning
Address Table	4K entries
Queue Buffer	1M shared memory
Address Resolution	via fast hashing scheme
Filtering Rate	14,880 pps at 10 Mbps, 148,800 pps at 100 Mbps
Forwarding Rate	14,880 pps at 10 Mbps, 148,800 pps at 100 Mbps

AT-FH807u Uplink Module

100Base-FX

Access Method	CSMA/CD, 100 Mbps
Standards Conformance	IEEE 802.3u 100Base-FX
Communication Rate	100 Mbps
Communication Mode	Half- or full-duplex (auto-negotiation)
Media Supported	50/125 micron or 62.5/125 micron multimode fiber
Number of Ports	One 100Base-FX SC-type port
Indicator Panel	LEDs for port link, collision, transmit, receive, transmission mode

AT-FH808u Uplink Module

10Base-T/100Base-TX

Access Method	CSMA/CD, 10 or 100 Mbps
Standards Conformance	IEEE 802.3u 100Base-TX
Communication Rate	10 or 100 Mbps (auto-negotiation)
Communication Mode	Half- or full-duplex (auto-negotiation)
Media Supported	10Base-T 100 Ohm Category 3,4,5 UTP/STP, 100Base-TX 100 Ohm Category 5 UTP/STP
Number of Ports	One 10/100Base-TX RJ45 port (MDI-X or MDI connection)
Indicator Panel	LEDs for port link, collision, activity, transmission mode

Appendix B

Technical Support Fax Order

Name _____
Company _____
Address _____
City _____ State/Province _____
Zip/Postal Code _____ Country _____
Phone _____ Fax _____

Incident Summary

Model number of Allied Telesyn product I am using _____

Network software products I am using _____

Brief summary of problem _____

Conditions (list the steps that led up to the problem) _____

Detailed description (use separate sheet, if necessary) _____

When completed, fax this sheet to the appropriate Allied Telesyn office. Fax numbers can be found on page viii.

Appendix C

AT-FH800 Series Installation Guide Feedback

Please tell us what additional information you would like to see discussed in this guide. If there are topics you would like information on that were not covered in this guide, please photocopy this page, answer the questions and fax or mail this form back to Allied Telesyn. The mailing address and fax number are at the bottom of this page. Your comments are valuable when we plan future revisions of this guide.

I found the following the most valuable _____

I would like the following more developed _____

I would find the guide more useful if _____

Please fax or mail your feedback. Fax to 1-408-736-0100. Or mail to:
Allied Telesyn International, Corp.
c/o Technical Communications
960 Stewart Drive, Suite B
Sunnyvale, CA 94085 USA

PN 613-10753-00 Rev G

Free Manuals Download Website

<http://myh66.com>

<http://usermanuals.us>

<http://www.somanuals.com>

<http://www.4manuals.cc>

<http://www.manual-lib.com>

<http://www.404manual.com>

<http://www.luxmanual.com>

<http://aubethermostatmanual.com>

Golf course search by state

<http://golfingnear.com>

Email search by domain

<http://emailbydomain.com>

Auto manuals search

<http://auto.somanuals.com>

TV manuals search

<http://tv.somanuals.com>