

# SLS6221

## SYSTEM SPECIFICATIONS

Frequency Response:	32 Hz – 18 kHz (-10 dB)
Maximum Output:	101 dB SPL (1m)
System Power:	58 watts RMS @ 1% THD
Satellite Power:	7 watts RMS @ 1% THD
Subwoofer Power:	44 watts RMS @ 1% THD
System THD (Input to Amplifier Output):	<0.6% THD @ 1 kHz
Signal-to-Noise Ratio:	> 78 dB
Channel Separation:	> 55 dB
Input Impedance:	10 k ohm
Input Sensitivity:	-11.76 dBu (200 mV RMS)
Maximum Input Level:	+12 dBu (3.08 V RMS)
Volume Control:	70 dB attenuation maximum
Treble Level Control:	+/- 9 dB @ 10 kHz
Bass (Subwoofer) Level Control:	+/- 10 dB @ 100 Hz
Recommended Headphone Load Impedance:	32 ohms, each channel
Headphone Output:	7mW into 32 ohms, both channels driven
Drivers (per satellite):	Six 1" / 25 mm full-range 8 ohm micro drivers
Subwoofer Driver:	One 6.5" / 165 mm long-throw 4 ohm woofer
Cables (Supplied with SLS6221)	<ul style="list-style-type: none"><li>• Satellite: 4-pin DIN cable (3 m / 9.8 ft.) with extension (2 m / 6.6 ft.)</li><li>• Controller: 9-pin DIN cable (3 m / 9.8 ft.)</li><li>• RCA input cable (5 m / 16.3 ft.)</li></ul>
AC Power Requirements:	<ul style="list-style-type: none"><li>• 120 V AC @ 60 Hz (USA, Canada and applicable Latin American and Asian countries).</li><li>• International versions with 220 V &amp; 230 V power supplies are available.</li></ul>
Input Connections:	<ul style="list-style-type: none"><li>• Stereo RCA inputs Red (right) and White (left) on rear panel of subwoofer.</li><li>• One 3.5 mm stereo input on rear panel of subwoofer.</li><li>• One 3.5 mm auxiliary input is located on the wired control pod.</li></ul>
Controls:	<ul style="list-style-type: none"><li>• Wired Control Pod: Rotary Up/Down Volume, Bass, Treble, and On/Standby</li><li>• Infrared Wireless Remote: Up/Down Volume, Bass, Treble, and On/Standby</li></ul>
Enclosure Material & Finish:	<ul style="list-style-type: none"><li>• Satellites: Black injection-molded plastic with painted metal grill</li><li>• Subwoofer: Black painted 9 mm MDF with injection-molded front panel and painted metal grill</li></ul>
Satellite Dimensions:	<ul style="list-style-type: none"><li>• 2.5" (W) x 1" (D) x 14.4" (H)</li><li>• 64 mm (W) x 26 mm (D) x 365 mm (H)</li></ul>
Subwoofer Dimensions:	<ul style="list-style-type: none"><li>• 8.5" (W) x 7.9" (D) x 16" (H)</li><li>• 216 mm (W) x 198 mm (D) x 406 mm (H)</li></ul>
Weight:	<ul style="list-style-type: none"><li>• Shipping: 22.5 lbs (10.2 kg)</li><li>• Net weight of satellites, subwoofer and control pod: 19 lbs (8.6 kg)</li></ul>

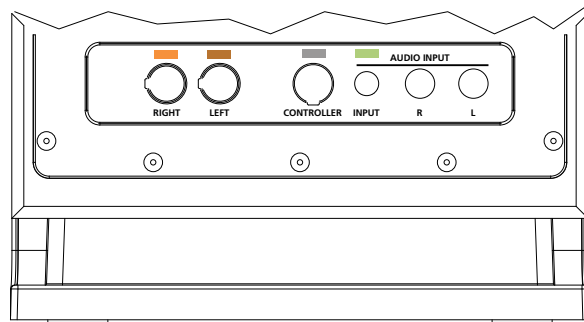

**ALTEC  
LANSING**  
PROFESSIONAL

© 2004 Altec Lansing Professional. All rights reserved.  
1000 W. Wilshire Blvd., Suite 362, Oklahoma City, OK 73116  
Tel. 405-848-3108 / Fax. 405-848-3216 / proinfo@altec Lansing.com  
Visit [www.altecp.com](http://www.altecp.com)

Proudly distributed by  
**ELECTROGRAPH**  
Your Display Technology Distributor™  
in the United States [www.electrograph.com](http://www.electrograph.com) 1-800-776-5768

Download from [Www.Somanuals.com](http://Www.Somanuals.com)

# ALTEC LANSING®

---

## PROFESSIONAL

## INTRODUCING A SOUND SOLUTION FOR ALL FLAT PANEL DISPLAYS

Visual communication is a powerful thing, but nothing adds to the overall impact like high-fidelity audio. Flat panel displays (FPDs) are the video communication media of choice for corporate, institutional, retail, and commercial clients – anyone who wants to present high-impact, high-resolution visual information.

Unfortunately, choices for FPD audio playback have been limited to low-performance, poor-quality speaker systems. *Until now.*

Introducing the Altec Lansing SLS6221 system. The first professional-quality 2.1 powered audio system specifically designed for use with FPDs. Now you can provide your clients with high-fidelity, high-definition audio to match the quality of their video presentations.

## ADVANCED TECHNOLOGY DELIVERS PREDICTABLE SOUND COVERAGE

Whether placed at the head of a corporate board room or as part of a high traffic point-of-sale retail kiosk surrounded by reflective surfaces and high ambient noise, the sound must be delivered to its audience with minimal impact to surrounding locations. The Altec Lansing SLS6221 uses patent pending line array technology to focus voice and music into the area directly in front of the plasma screen.

### POWERFUL SUBWOOFER

A ported subwoofer completes the sound with low-frequency, full-throated bass. Set in a low-resonance wood cabinet for maximum sound with minimal distortion, the narrow-profile cabinet contains a long-throw 6.5" (165 mm) woofer designed to reproduce dynamic audio program material down to 32 Hz. The subwoofer also contains seven discrete power amplifiers and the line array circuitry.



### THE WORLD'S SMALLEST LINE ARRAY

The Altec Lansing SLS6221 features two ultra-slim satellites with a total of twelve 1" neodymium micro drivers, with each pair of micro drivers powered by its own discrete amplifier. From 150 Hz to 20 kHz, the frequency spectrum is split into three distinct overlapping bands and fed into micro drivers that are set at a precise distance from each other. A combination of precise driver spacing and low pass filters for each pair of drivers delivers a predictable vertical coverage pattern of 40° - 60° above 1,500 Hz. The end result is a crisp, high-fidelity, fully intelligible sound that is focused on the listening area.



### VERSATILITY OF INSTALLATION

Each SLS6221 system comes with three convenient mounting options:

- Bracket system to mount the speakers to the center mounting position of most FPDs.
- Satellite stands for use on table tops.
- Threaded inserts on the back of each satellite for surface or ceiling mounting using standard industry mounting brackets.

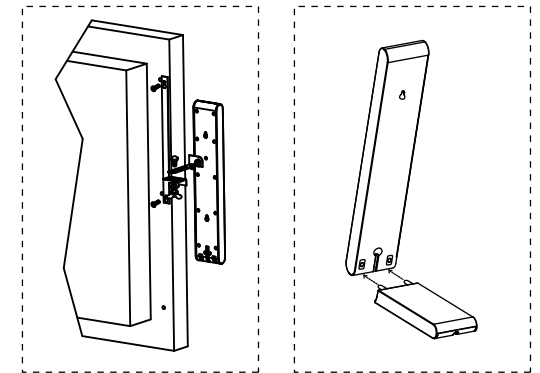

Orange = Discernable sound

Note the controlled, uniform vertical dispersion pattern of the high-frequency program material. The audio is directed at the listener, not at floor or ceilings. The music and voice reproduction comes right at you, in its purest, most natural form uncluttered by reflections.

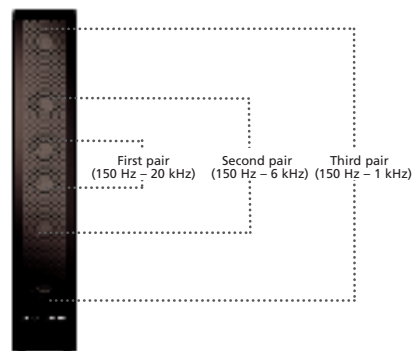
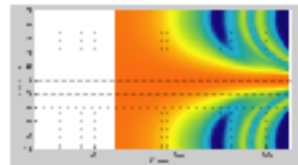

Low pass filtering actively directs specified frequencies of sound to a different pair of micro drivers. This process, combined with the critical distance between each micro driver, creates the focused coverage pattern in front of the flat panel display.



Hard-wired cables (3 m / 9.8 ft.) with an additional extension cable (2 m / 6.6 ft.) are provided for satellite to subwoofer connections. A stereo RCA input cable (5 m / 16.3 ft.) is also provided for connecting the FPD to the subwoofer.

### ADDITIONAL FEATURES

- SLS6221 satellites are magnetically shielded to work with any kind of display, including standard CRTs. The subwoofer is not magnetically shielded.
- A wired control pod and wireless IR remote allow you to adjust volume, bass and treble, as well as mute the entire system.
- A headphone jack located on the control pod allows private monitoring of the audio output. Use of the headphone jack mutes the speakers.
- The SLS6221 is offered in 120 V, 220 V and 230 V versions.



## Free Manuals Download Website

<http://myh66.com>

<http://usermanuals.us>

<http://www.somanuals.com>

<http://www.4manuals.cc>

<http://www.manual-lib.com>

<http://www.404manual.com>

<http://www.luxmanual.com>

<http://aubethermostatmanual.com>

Golf course search by state

<http://golfingnear.com>

Email search by domain

<http://emailbydomain.com>

Auto manuals search

<http://auto.somanuals.com>

TV manuals search

<http://tv.somanuals.com>