

Overview - NetLinx Hub Cards and Modules

NetLinx Hub Cards distribute ICSP (Internet Control System Protocol) throughout a NetLinx control system. ICSP packets can move easily between different kinds of networks including Ethernet, Internet, and the NetLinx (ICSNet) control bus.

The NetLinx Hub Cards covered in this document are:

- NXC-NH ICSNet Hub Card (**FG2060**)
- NXC-HS ICSHub Server Card (**FG2061**)
- NXC-HE ICSHub Expander Card (**FG2062**)

The NXS-MHS Modules (**FG2009**) provide enclosures for the Hub Cards. The NetLinx ICSNet control network branches from a NetLinx Master to ICSNet devices via ICSHub data links. An ICSNet Hub Card can then distribute data and power to up to eight system devices through multiple ICSNet wiring runs. Each ICSNet wiring run can support up to 16 devices connecting from one to another, in a daisy-chain fashion. FIG. 1 shows a sample application using a connection from the Master to the ICSNet Hub Card, then to external ICSNet devices.

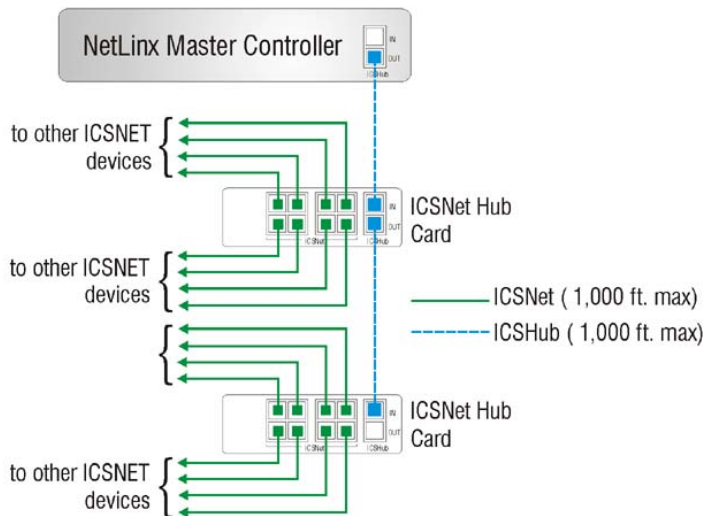

FIG. 1 Sample ICSNet Hub Card Daisy-chain configuration

ICSHub and ICSNet links can extend up to 1,000 feet (304.8 m). Each link is fully regenerated at every ICSHub connection to allow systems to connect over virtually unlimited distances. Hub Cards can be installed in an NXI (NetLinx Integrated Controller), NXF (CardFrame), or NXM-MHS (Module) for stand-alone operation.

Specifications

Specifications	
Power Requirements:	<ul style="list-style-type: none"> • NXC-NH - 180 mA @ 12 VDC • NXC-HS - 160 mA @ 12 VDC • NXC-HE - 110 mA @ 12 VDC
PWR connector/LED:	2-pin 12 VDC power connector (green); supply depends on load. Green LED lights to indicate power.
ICSNet OUT (NXC-NH):	Eight RJ-45 connectors that supply power and data to external ICSNet devices. Max. current draw = 500 mA. <ul style="list-style-type: none"> • Yellow LEDs (one per port) blink when sending data on the associated port(s).
ICSHub OUT (NXC-HS):	Nine RJ-45 ports for ICSHub data. <ul style="list-style-type: none"> • Yellow LEDs blink when receiving data on the associated OUT ports.
ICSHub IN: NXC-HS	RJ-45 connector that supplies data to other NetLinx Controllers and Hubs, and wired using a daisy-chain configuration. The OUT port of one ICSHub must be connected to the IN connector of a downstream ICSHub Module or Card. <ul style="list-style-type: none"> • Yellow LED blinks when receiving data.

Specifications (Cont.)

ICSHub IN/OUT:	<ul style="list-style-type: none"> • NXC-NH <ul style="list-style-type: none"> • RJ-45 connectors that supply data to other ICSHubs connected to the Master Card. The OUT port of one ICSHub must be connected to the IN connector of a downstream ICSHub Module or card. • Yellow LEDs blink when receiving data on the associated IN/OUT ports. • NXC-HE <ul style="list-style-type: none"> • RJ-45 connectors that supply data to other Hubs connected to the Master Card, and wired using a daisy-chain configuration. The ICSHub OUT connector of one Hub must be connected to the ICSHub IN connector on the downstream Hub. • Yellow LEDs blink when receiving data on the associated IN/OUT ports.
Optional Accessories:	<ul style="list-style-type: none"> • NXM-MHS module <ul style="list-style-type: none"> • Metal with black matte finish- • Plastic gray faceplate with translucent viewing window.
12 VDC power supply	<ul style="list-style-type: none"> • PS2.8 (FG423-05) • PSN6.5 (FG423-41)
Rack Kit	AC-RK Accessory (FG515)
Dimensions (HWD):	1.5" x 5.0" x 8.8" (45 mm x 127 mm x 224 mm)
Weight:	26 oz (737 g)

NXC-NH ICSNet Hub Card

The NXC-NH ICSNet Hub Card provides eight ICSNet ports. FIG. 2 shows its rear panel components. This card connects to external ICSNet devices.

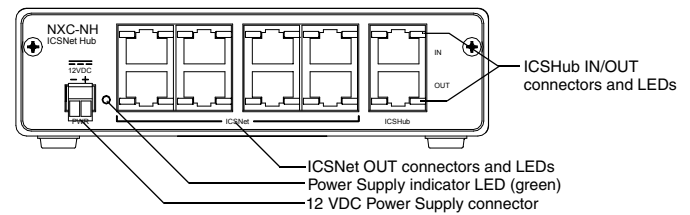

FIG. 2 NXC-NH Card (shown mounted in NXM-MHS Module - rear view)

Rear Panel LEDs

FIG. 3 shows the layout of the ICSNet and ICSHub LEDs.

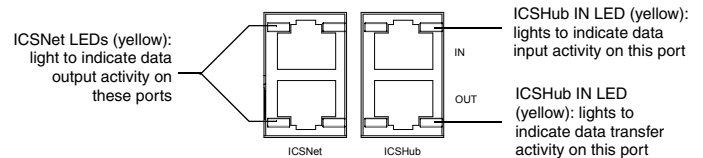

FIG. 3 Layout of the ICSNet and ICSHub IN/OUT LEDs

NXC-HS ICSHub Server Card

The NXC-HS Server Card provides nine ICSHub OUT ports for connecting NetLinx Controllers and Hubs, and one ICSHub IN port. FIG. 4 shows its rear panel components. This card connects to either ICSNet Hubs or other Hub servers.

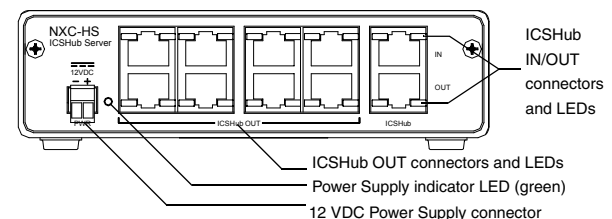

FIG. 4 NXC-HS Card/Module (shown mounted in NXM-MHS Module - rear view)

Rear Panel LEDs

FIG. 5 shows the layout of the ICSHub LEDs.

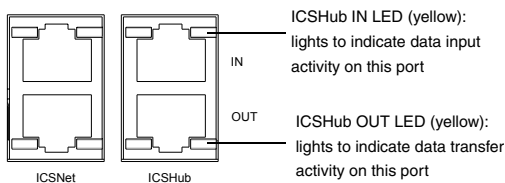

FIG. 5 Layout of the ICSHub IN/OUT LEDs

NXC-HE ICSHub Expander Card

The NXC-HE ICSHub Expander Card can be used as an ICS hub cable extender where runs between ICS hubs are over 1,000 feet (304.8 m). The NXC-HE Card can also be used in place of a Master card in a NXI (NetLinX Integrated Controller) or NXF (CardFrame) to be used as slave devices. FIG. 6 shows its rear panel components.

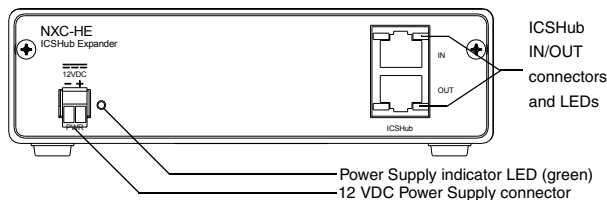

FIG. 6 NXC-HE Card/Module (shown mounted in NXM-MHS Module - rear view)

Rear Panel LEDs

FIG. 7 shows the layout of the ICSHub LEDs.

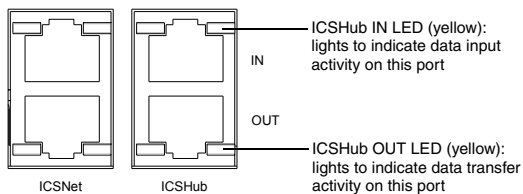

FIG. 7 Layout of the ICSHub IN/OUT LEDs.

Installation and Wiring

Mounting the Modules into an equipment rack

To install the Modules into an equipment rack, you'll need an optional AC-RK Kit:

1. Remove the front faceplate from the Module to expose the mounting holes.
2. Mount the module on the AC-RK bracket.
3. Place the AC-RK bracket (with the module) in the equipment rack and secure the bracket to the rack.
4. Replace the front panel to the Module, and attach the magnetic, translucent faceplate (if necessary).

Preparing/connecting captive wires

1. Strip 0.25 inch of wire insulation off all wires.
2. Insert each wire into the appropriate opening on the connector according to the wiring diagrams and connector types described in this section.
 - Do not tighten the screws excessively; doing so may strip the threads and damage the connector.

ICSNet RJ-45 Connections/Wiring

The following table shows the pinouts, signals, and pairing information to use for ICSNet RJ-45 connections. The ICSNet connections provide power and data to ICSNet devices. Each port provides up to 500 mA of current.

ICSNet RJ-45 Pinouts/Signals			
Pin	Signal	Connections	Pairing
1	TX +	1 ----- 1	1 ----- 2
2	TX -	2 ----- 2	
3	Mic -	3 ----- 3	3 ----- 6
4	GND	4 ----- 4	
5	12 VDC	5 ----- 5	4 ----- 5
6	Mic +	6 ----- 6	
7	RX +	7 ----- 7	7 ----- 8
8	RX -	8 ----- 8	

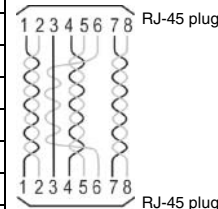

ICSHub RJ-45 Connections/Wiring

Use CAT5 cables for all ICSHub connections.

Do not connect the last hub in a daisy-chain configuration into the first hub. The following table shows the pinouts and signals for ICSHub RJ-45 connections.

ICSHub Pinouts and Signals			
IN Port		OUT Port	
Pin	Signal	Pin	Signal
1	TX -	1	RX +
2	TX +	2	RX -
7	RX -	7	TX +
8	RX +	8	TX -

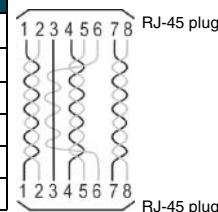

Free Manuals Download Website

<http://myh66.com>

<http://usermanuals.us>

<http://www.somanuals.com>

<http://www.4manuals.cc>

<http://www.manual-lib.com>

<http://www.404manual.com>

<http://www.luxmanual.com>

<http://aubethermostatmanual.com>

Golf course search by state

<http://golfingnear.com>

Email search by domain

<http://emailbydomain.com>

Auto manuals search

<http://auto.somanuals.com>

TV manuals search

<http://tv.somanuals.com>