

HAVING TROUBLE W/ YOUR SOUND SYSTEM?

CONDITION

No Sound (power LED = OFF)

No Sound (power LED = ON)

Distorted Sound

Excessive Hum or Noise

POSSIBLE CAUSE

- power switch is in OFF position
- blown fuse
- no output from source
- input cable unplugged
- input volume control low or off
- accessory or expansion module not in option bay
- poor or improper connection on input cable
- input signal too strong
- input cable not shielded
- not using balanced microphone

HAVING TROUBLE W/ YOUR WIRELESS SYSTEM? (Wireless Models Only)

CONDITION

No Sound (TX ON indicator lights)

No Sound (TX ON indicator off)

POSSIBLE CAUSE

- wireless volume control low or off
- no mic plugged into belt-pack transmitter
- sound system not turned on
- transmitter power switch turned off
- low battery or no battery in transmitter

Anchor Audio Customer Service

888-444-6077

XTREME TECHNICAL SPECIFICATIONS

Rated Power Output	stand-alone	w/ XTR-6001 companion	Sensitivity For Rated Output
Low Frequency Amp	90 watts	125 watts	Unbalanced Line -18 dBV / 125 mVrms
High Frequency Amp	40 watts	55 watts	Balanced Mic -58 dBV / 1.25 mVrms
Max SPL@Rated Power	116 dB (speech projection = off)		Balanced Mic Input -58 dBV / 1.25 mVrms
	123 dB (speech projection = on)		Balanced Line Input -15 dBV / 175 mVrms
General			Outputs
Frequency Response	80 Hz - 15 kHz (speech = off)		Line Output (post fader) XLR male, 600 ohm, active balanced
	+7 dB from 2 - 12 kHz (speech = on)		Speaker Output 4-pole Neutrik Speakon® jack
Bass/Treble Control	8 dB cut/boost @ 100 Hz, 8 kHz		use w/ Anchor XTR-6001
Inputs			AC Power Requirements 110 - 125 VAC, 50/60 Hz, 250 watts max
Line Input	1/4" phone, Hi-Z, unbalanced		210 - 240 VAC, 50/60 Hz, 250 watts max
Mic Input	XLR, Lo-Z +12VDC condenser mic power		Dimensions (HWD) 22.5 x 13 x 10" / 57 x 33 x 26 cm
Balanced Input	XLR, switchable mic/line level		Weight 35 pounds / 16 Kg
	+12VDC condenser mic power		

(Specifications subject to change without notice)



Xtreme

Portable Sound System

OWNER'S MANUAL



CONTENTS

GETTING STARTED - WARRANTY INFORMATION	2
SETTING UP YOUR XTREME SOUND SYSTEM.....	2
FEEDBACK - CONNECTING XTREME SOUND SYSTEMS - SPEAKER STAND SETUP	3
SOUND SYSTEM ACCESSORIES.....	4
XTREME SOUND SYSTEM BASIC OPERATION.....	4/5
OPERATING THE BUILT-IN UHF WIRELESS RECEIVER	6
OPERATING THE BUILT-IN CD PLAYER	6
OPERATING THE WIRELESS MICROPHONE/TRANSMITTER	7
HAVING TROUBLE W/ YOUR SOUND SYSTEM?.....	8
XTREME TECHNICAL SPECIFICATIONS.....	8



Anchor Audio, Inc.

Portable Sound Systems • Torrance, California

100-0135-000/B- 10/06

Download from www.somanuals.com. All Manuals Search And Download.

A MESSAGE FROM THE OWNER

Thank you for choosing an Anchor Audio portable sound system. Our products incorporate state-of-the-art design and the finest quality of materials and workmanship. We're proud of our products and appreciate the confidence which you have shown by selecting an Anchor system.

I hope you'll take a few minutes to review this manual. We've incorporated several unique features into our products, and your knowledge of how to use them will enhance the performance and your enjoyment of the system.

David Jacobs, President
on behalf of all Anchor Employees

GETTING STARTED

Please check your new unit carefully for any damage which may have occurred during shipment. Each Anchor product is carefully inspected at the factory and packed in specially designed boxes for safe transport.

Notify the freight carrier immediately of any damage to the shipping box or product. Repack the unit in the original box and wait for inspection by the carrier's claim agent. Notify your dealer of the pending freight claim.

NOTE: All damage claims must be made with freight carrier!

RETURNING SYSTEMS FOR SERVICE OR REPAIR

For service or repair, please contact the dealer you purchased your system from or Anchor Audio Customer Service at (888) 444-6077 to obtain a RA (Return Authorization) number. All shipments to Anchor Audio must include an RA number and must be shipped prepaid. C.O.D. shipments will be refused and returned at your expense.

IMPORTANT: Save the shipping box & packing materials, they were specially designed to ship your unit!

WARRANTY REGISTRATION

Visit our website at www.anchoraudio.com and select "Warranty Registration". Complete the online form to activate the six-year limited warranty on your Xtreme sound system and two-year limited warranty for the CD player and microphones.

SETTING UP YOUR XTREME SOUND SYSTEM

We recommend placing your sound system between the audience and the presenter, facing the audience and raised above their heads using a speaker stand or table. This benefits listeners in the rear of the crowd, minimizes the risk of overpowering those in the front and helps prevent feedback by keeping microphone users behind the sound system.

SINGLE SYSTEM PLACEMENT

Place your unit along the least trafficked aisle pointing towards the center of the audience.

MULTIPLE SYSTEM PLACEMENT

Place units along aisles pointing just off the audience center line, over the crowd's head. With the sound system placed properly it should provide sufficient coverage.

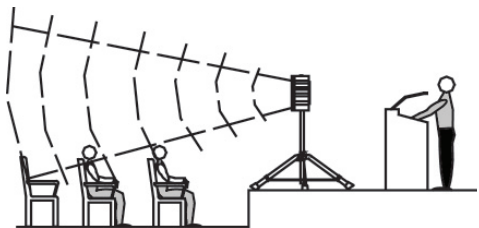

NOTE: The line-output feature can also be used to send the signal to a sound system in a different room or a separate recording device.

OPERATING THE WIRELESS MICROPHONE/TRANSMITTER

CHANNEL SELECTION - HANDHELD TRANSMITTER

1. Unscrew battery cover on bottom of microphone
2. Set the CHANNEL SELECTOR dial to match the channel setting of your receiver
3. Replace battery cover and tighten firmly

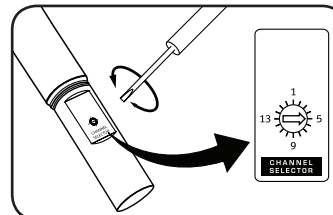

CHANNEL SELECTION - BODY-PACK TRANSMITTER

1. The channel selection dial is located on the side of the transmitter
2. Set the CHANNEL selection dial to match the channel setting of the receiver

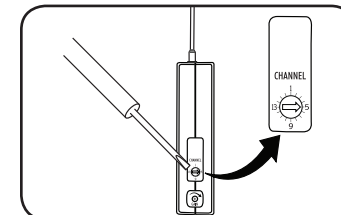

NOTE: When using dual wireless, each microphone must be set to a different channel!

USING YOUR WIRELESS MICROPHONES

After you have set the transmitter channel (see above) you are ready to use your wireless microphone:

1. Body-pack transmitter users must insert the mic plug into the transmitter jack marked MIC
2. Turn the transmitter power switch to ON (The red LED will flash when the mic is turned on. If the red LED stays on, the battery is low)
3. Turn the Xtreme power switch to ON
4. The RX indicators will light (only one indicator will light at a time) when the wireless signal is being transmitted and received

CAUTION: Harmful feedback may occur when walking in front of a sound system or speaker with a wireless microphone. Always point microphone away from speakers!

REPLACE BATTERY - HANDHELD TRANSMITTER

1. Unscrew battery cover on bottom of microphone
2. Replace old batteries with 2 fresh size 'AA' alkaline batteries
3. Replace battery cover and tighten firmly

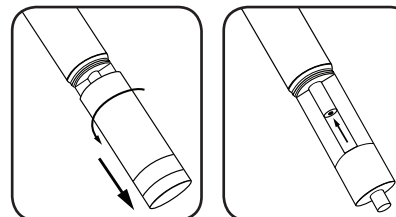

REPLACE BATTERY - BODY-PACK TRANSMITTER

1. Slide open battery cover on front of transmitter
2. Replace old batteries with 2 fresh size 'AA' alkaline batteries
3. Replace battery cover by sliding firmly into place

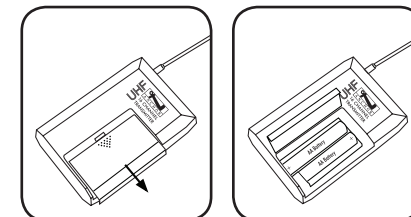

NOTE: Transmitter power must be OFF when changing batteries!

DIVERSITY WIRELESS BY ANCHOR AUDIO

Anchor Audio UHF wireless is a 16 channel, diversity wireless system that receives signals with two independent antennae. With diversity wireless the receiver processes the stronger signal, effectively minimizing dropouts and interference from other transmitting sources. The antennae are mounted internally so there are no obstructions or risk of damage.

CHANNEL SELECTION - BUILT-IN RECEIVER

Select a channel, set the built-in receiver & microphone transmitter to that channel before using your wireless system.

1. Choose any available wireless channel/frequency from 1 thru 16 (see page 7 for transmitter setup instructions)
2. Turn the Wireless Channel Selector Knob to the channel/frequency you choose in step 1

If you have two wireless receivers repeat above for the second receiver. Remember each receiver/transmitter pair must be set to different channels for proper operation.

NOTE: Ongoing wireless interference? The frequency you selected may be in use by other systems in the area! Change channels until you find a clear frequency!

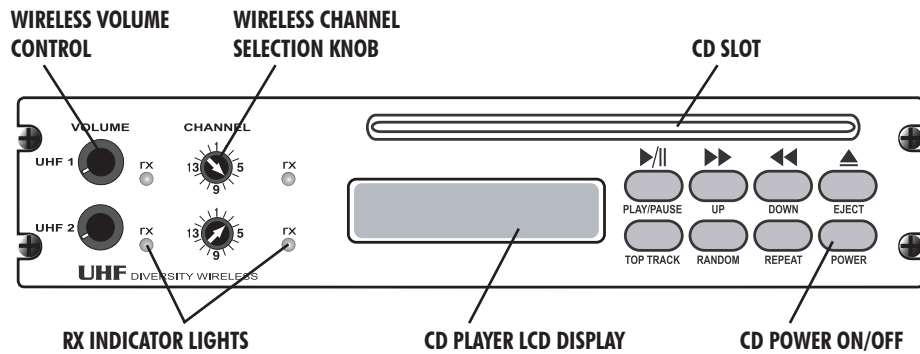

OPERATING THE BUILT-IN CD PLAYER

Your built-in CD player features 'direct-in' play, power loading, anti-shock/skip CD mechanism, repeat & random play, three beam laser tracking system and dual one bit D/A converters. By feeding the CD audio signal directly into the mixing bus the Xtreme Sound System is able to create a crisp, clear composite output of all your system inputs.

CD PLAYER BASIC OPERATION

Insert a disc into the player by gently sliding it, label side up, into the CD slot. The player will automatically load and begin playback from the beginning of the disc. CD player controls are explained in detail below:

PLAY/PAUSE	Press to play a loaded CD. Press during playback to pause, press again to resume.	TOP TRACK	Press once to start playing the disc from the first track.
UP	Press once to advance CD to next track. Press and hold to fast forward on the current track.	RANDOM	Press for continuous, random track playback. Press again to resume normal play.
DOWN	Press once to go to previous track. Press and hold to fast backward on current track.	REPEAT	Press for continuous playback of the same track. Press again to resume normal play.
EJECT	Press to unload a disc from the player. If CD is not removed within 10 seconds it will be automatically reloaded into the player.	POWER	Press to turn the CD player on/off. The sound system will need to be turned off separately.

CAUTION: To avoid noise at shut off, turn CD player off before you turn off the Xtreme!

FEEDBACK

Feedback, a howling noise or shrill sound, is self-generated by the sound system. It's caused by a microphone picking up the sound coming from the speaker and then re-amplifying it. Once a feedback loop starts it continues until the system is adjusted.

FEEDBACK CAUSES

- Microphone too close, pointing towards or in front of speaker
- Volume setting is too loud for room
- Sound reflecting off hard surfaces

AVOIDING & ELIMINATING FEEDBACK

- Point microphone in a different direction
- Keep microphone away from the speaker
- Place speaker in FRONT of the microphone
- Reduce the sound system volume levels

CORRECT SYSTEM PLACEMENT

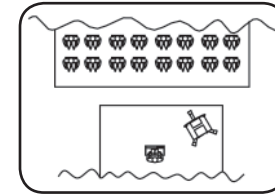

WRONG SYSTEM PLACEMENT

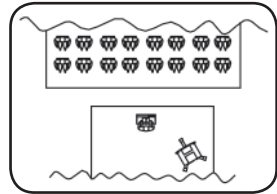

CAUTION: Feedback can damage your equipment & may be hazardous to hearing.

CONNECTING TWO OR MORE XTREME SOUND SYSTEMS

USING A XTREME UNPOWERED COMPANION SPEAKER (XTR-6001)

Connect one end of a speaker cable (SC-50NL) to the COMPANION SPEAKER OUTPUT jack on the back of a powered Xtreme sound system. Connect the other end to the jack labeled IN on the back of a Xtreme unpowered companion speaker.

NOTE: AC power is not required for an unpowered companion speaker.

USING POWERED XTREME SYSTEMS

The Balanced Line Output feature allows you to connect two or more powered Xtreme's and control all volume levels from the primary system.

1. Connect a speaker cable (EX-50PP) to the BALANCED LINE OUT jack on the first/primary powered Xtreme
2. Connect other end of cable to the BALANCED INPUT jack on the second powered Xtreme
3. Set the Level Control for the Balanced Input on the second Xtreme to maximum
4. Connect additional systems following 1 - 3 above

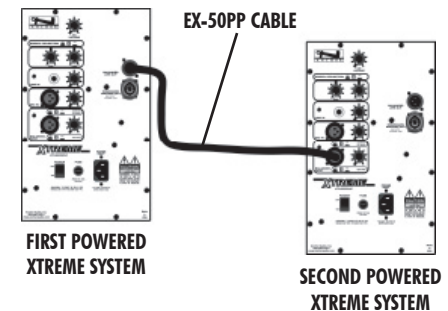

NOTE: The Balanced Line Output feature can also be used to send the signal to a sound system in a different room or a separate recording device.

SPEAKER STAND SETUP

1. Loosen the Lower Collar Knob
2. Separate the stand legs until the leg support Cross Braces are parallel to the floor
3. Tighten the Lower Collar Knob

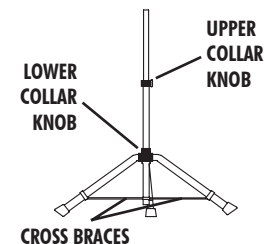

4. Loosen the Upper Collar Knob and extend the center pole
5. Adjust height and retighten the Upper Collar Knob
6. Place your Anchor sound system on the stand

BASIC SYSTEM OPERATION

NOTE: Fully Charge Batteries Before First Use!

1. Before turning your system on: Set all Input Level Controls to minimum & Tones Controls to the flat or middle setting
2. Plug in a wired microphone (MIC IN or BALANCED INPUT jacks) and/or a separate audio source (LINE-IN jack)
3. Set Power Switch to "ON", a red LED near switch will light up
4. Adjust Level Controls for active Input Jacks to desired volume
5. Speech/Projection Button: ON for speech applications or OFF for music & indoor use
6. Adjust sound quality w/ the BASS & TREBLE Tone Controls

SOUND SYSTEM ACCESSORIES

XTR-6001 - Xtreme Companion Speaker

Unpowered dual function companion speaker (speaker cable not included)

SC-50NL - Heavy Duty Speaker Cable

50' speaker cable, use to connect the XTR-6001 to a powered Xtreme system

SC-100NL - Heavy Duty Speaker Cable

100' speaker cable, use to connect the XTR-6001 to a powered Xtreme system

SS-550 - Heavy Duty Speaker Stand

Adjustable stand made of black, anodized aluminum

HC-1650L/X - Hard Case

For travel or storage - holds one Xtreme sound system & accessories

SOFT-TOTE - Soft Rolling Case

Soft case w/ wheels & collapsible handle, holds Xtreme, stand & accessories

MIC-90 - Handheld Wired Microphone

Anchor's dynamic, balanced, low impedance microphone w/ unidirectional pick-up pattern, mic "on/off" switch, 20' cable & mic clip

ANCHOR WIRELESS - 16 CHANNEL UHF

WH-6000 - Handheld Microphone/Transmitter

WB-6000 - Body Pack Transmitter

Works w/ hands free microphones (mic not included - see below)

CM-60 - Collar Microphone

Lightweight, low-profile mic - works w/ WB-6000 body pack transmitter

EM-60T - UltraLite Microphone

Hands free "Over-the-Ear" mic - works w/ WB-6000 body pack transmitter

LM-60 - Lapel Microphone

Lightweight, clip-on lapel mic - works w/ WB-6000 body pack transmitter

HBM-60 - Headband Microphone

Ultra-lightweight headband mic - works w/ WB-6000 body pack transmitter

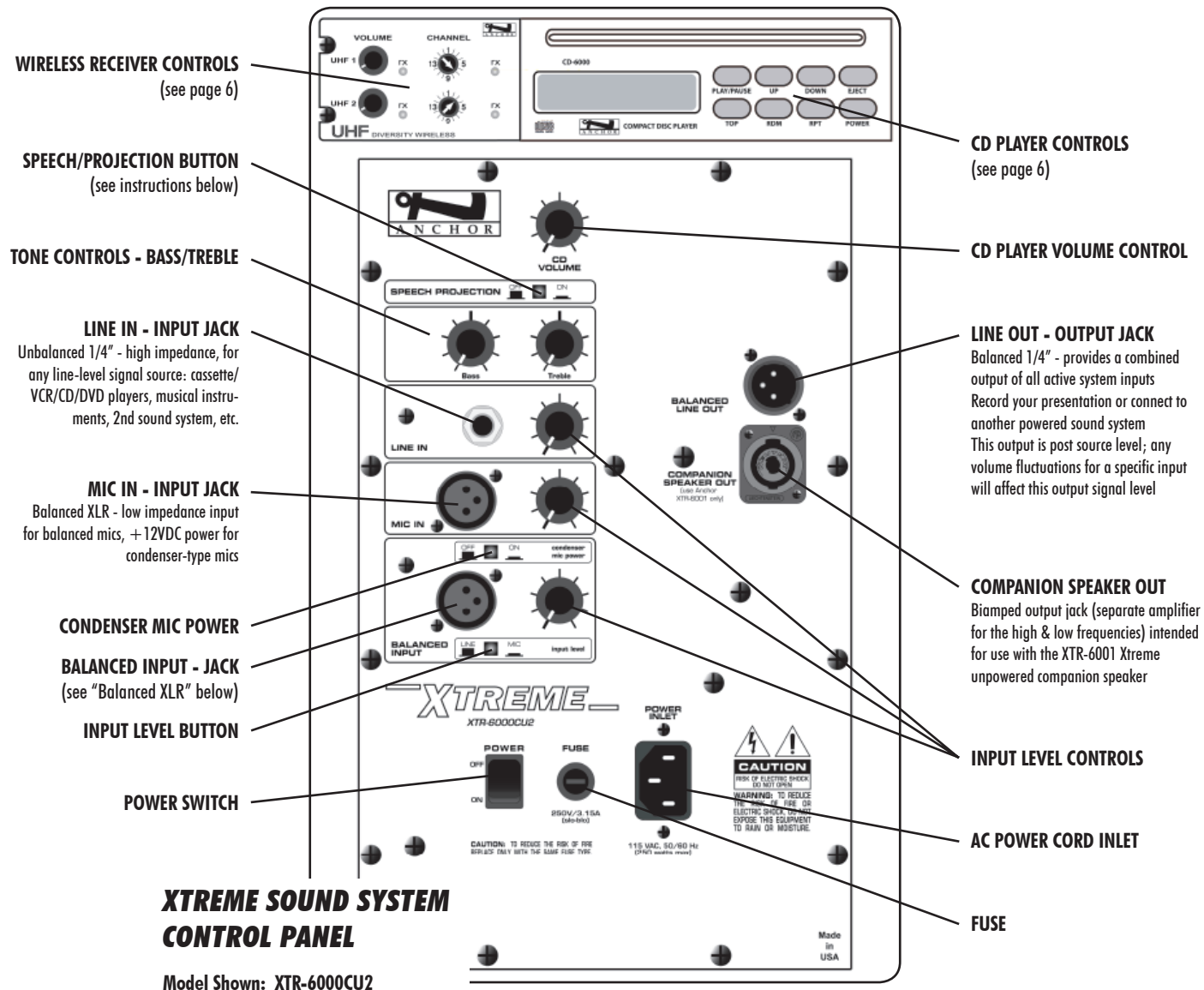

BALANCED XLR INPUT

The balanced XLR, low impedance input jack can be used for either a balanced line level input or a balanced microphone input. The Input Level & Condenser Mic Power features are user selectable.

Condenser Mic Power Button: For condenser microphones, set the Condenser Mic Power button to "ON" (button in); the "ON" setting supplies +12VDC at the input. Setting the button to "OFF" (button out) supplies 0V for all other input applications.

Input Level Button: For a microphone level input set the Input Level button to "MIC" (button in). For line level sources set the Input Level button to "LINE" (button out).

SPEECH/PROJECTION BUTTON

Allows you to customize the sound output of your Xtreme sound system for different applications:

Speech Projection Off (button out): A flat, full range frequency response for music or indoor voice applications.

Speech Projection On (button in): Frequencies in the vocal range are boosted for added clarity and efficient sound projection. Use this setting for outdoor functions, large crowds and speech applications.

Free Manuals Download Website

<http://myh66.com>

<http://usermanuals.us>

<http://www.somanuals.com>

<http://www.4manuals.cc>

<http://www.manual-lib.com>

<http://www.404manual.com>

<http://www.luxmanual.com>

<http://aubethermostatmanual.com>

Golf course search by state

<http://golfingnear.com>

Email search by domain

<http://emailbydomain.com>

Auto manuals search

<http://auto.somanuals.com>

TV manuals search

<http://tv.somanuals.com>