

MP1777A
10 GHz Jitter Analyzer
Remote Control
Operation Manual
Vol. 2

Fourth Edition

To ensure that the equipment is used safely, read the "For Safety" in the MP1777A 10 GHz Jitter Analyzer Operation Manual first.
Keep this manual with the equipment.

APR.
2005

ANRITSU CORPORATION



Document No.: M-W1493AE-4.0

Safety Symbols

To prevent the risk of personal injury or loss related to equipment malfunction, Anritsu Corporation uses the following safety symbols to indicate safety-related information. Insure that you clearly understand the meanings of the symbols BEFORE using the equipment.

Some or all of the symbols may not be used on this equipment. In addition, when drawings are included in this manual, labels on the equipment may not be shown on them.

Safety Symbols Used in Manual

- DANGER**  This indicates a very dangerous procedure that could result in death or serious injury if not performed properly.
- WARNING**  This indicates a hazardous procedure that could result in death or serious injury if not performed properly.
- CAUTION**  This indicates a hazardous procedure or danger that could result in light-to-severe injury, or loss related to equipment malfunction, if proper precautions are not taken.

Safety Symbols Used on Equipment and/or in Manual

The following safety symbols are used inside or on the equipment near operation locations, and/or in manual to provide information about safety items and operation precautions. Insure that you clearly understand the meanings of the symbols and take the necessary precautions BEFORE using the equipment.



This indicates a prohibited operation. The prohibited operation is indicated symbolically in or near the barred circle.



This indicates an obligatory safety precaution. The obligatory operation is indicated symbolically in or near the circle.



This indicates warning or caution. The contents are indicated symbolically in or near the triangle.



This indicates a note. The contents are described in the box.



These indicate that the marked part should be recycled.

MP1777A

10 GHz Jitter Analyzer Remote Control

Operation Manual Vol. 2

10 September 1998 (First Edition)

20 September 2002 (Fourth Edition)

Copyright © 1998-2002, ANRITSU CORPORATION.

All rights reserved. No part of this manual may be reproduced without the prior written permission of the publisher.

The contents of this manual may be changed without prior notice.

Printed in Japan

For Safety

WARNING



or



Repair

WARNING 

Falling Over

1. ALWAYS refer to the operation manual when working near locations at which the alert mark shown on the left is attached. If the operation, etc., is performed without heeding the advice in the operation manual, there is a risk of personal injury. In addition, the equipment performance may be reduced.

Moreover, this alert mark is sometimes used with other marks and descriptions indicating other dangers.

2. When supplying power to this equipment, connect the accessory 3-pin power cord to a 3-pin grounded power outlet. If a grounded 3-pin outlet is not available, before supplying power to the equipment, use a conversion adapter and ground the green wire, or connect the frame ground on the rear panel of the equipment to ground. If power is supplied without grounding the equipment, there is a risk of receiving a severe or fatal electric shock.

3. This equipment cannot be repaired by the user. DO NOT attempt to open the cabinet or to disassemble internal parts. Only Anritsu-trained service personnel or staff from your sales representative with a knowledge of electrical fire and shock hazards should service this equipment. There are high-voltage parts in this equipment presenting a risk of severe injury or fatal electric shock to untrained personnel. In addition, there is a risk of damage to precision parts.

4. This equipment should be used in the correct position. If the cabinet is turned on its side, etc., it will be unstable and may be damaged if it falls over as a result of receiving a slight mechanical shock.

For Safety

WARNING

Battery Fluid

5. DO NOT short the battery terminals and never attempt to disassemble it or dispose of it in a fire. If the battery is damaged by any of these actions, the battery fluid may leak.

This fluid is poisonous.

DO NOT touch it, ingest it, or get in your eyes. If it is accidentally ingested, spit it out immediately, rinse your mouth with water and seek medical help. If it enters your eyes accidentally, do not rub your eyes, irrigate them with clean running water and seek medical help. If the liquid gets on your skin or clothes, wash it off carefully and thoroughly.

LCD

6. This instrument uses a Liquid Crystal Display (LCD); DO NOT subject the instrument to excessive force or drop it. If the LCD is subjected to strong mechanical shock, it may break and liquid may leak.

This liquid is very caustic and poisonous.

DO NOT touch it, ingest it, or get in your eyes. If it is ingested accidentally, spit it out immediately, rinse your mouth with water and seek medical help. If it enters your eyes accidentally, do not rub your eyes, irrigate them with clean running water and seek medical help. If the liquid gets on your skin or clothes, wash it off carefully and thoroughly.

For Safety

CAUTION

Changing Fuse



1. Before changing the fuses, ALWAYS remove the power cord from the power outlet and replace the blown fuses. ALWAYS use new fuses of the type and rating specified on the fuse marking on the rear panel of the cabinet.

T ___A indicates a time-lag fuse.

There is risk of receiving a fatal electric shock if the fuses are replaced with the power cord connected.

Cleaning



2. Keep the power supply and cooling fan free of dust.
 - Clean the power inlet regularly. If dust accumulates around the power pins, there is a risk of fire.
 - Keep the cooling fan clean so that the ventilation holes are not obstructed. If the ventilation is obstructed, the cabinet may overheat and catch fire.

3. Use two or more people to lift and move this equipment, or use a trolley. There is a risk of back injury, if this equipment is lifted by one person.

Changing memory back-up battery

4. This equipment uses a lithium battery to back-up the memory. This battery must be replaced by a service engineer when it has reached the end of its useful life; contact the Anritsu sales section or your nearest representative.

NOTE: The battery used in this equipment has a maximum useful life of 7 years. It should be changed before this period has elapsed.

Disposing the batteries

5. The main unit of the MP1777A uses lithium batteries. When disposing of the batteries, make sure to conform with the local regulation.

Equipment Certificate

Anritsu Corporation certifies that this equipment was tested before shipment using calibrated measuring instruments with direct traceability to public testing organizations recognized by national research laboratories including the Electrotechnical Laboratory, the National Research Laboratory of Metrology and the Communications Research Laboratory, and was found to meet the published specifications.

Anritsu Warranty

Anritsu Corporation will repair this equipment free-of-charge if a malfunction occurs within 1 year after shipment due to a manufacturing fault, provided that this warranty is rendered void under any or all of the following conditions.

- The fault is outside the scope of the warranty conditions described in the operation manual.
- The fault is due to mishandling, misuse, or unauthorized modification or repair of the equipment by the customer.
- The fault is due to severe usage clearly exceeding normal usage.
- The fault is due to improper or insufficient maintenance by the customer.
- The fault is due to natural disaster including fire, flooding, earthquake, etc.
- The fault is due to use of non-specified peripheral equipment, peripheral parts, consumables, etc.
- The fault is due to use of a non-specified power supply or in a non-specified installation location.

In addition, this warranty is valid only for the original equipment purchaser. It is not transferable if the equipment is resold.

Anritsu Corporation will not accept liability for equipment faults due to unforeseen and unusual circumstances, nor for faults due to mishandling by the customer.

Anritsu Corporation Contact

If this equipment develops a fault, contact Anritsu Corporation or its representatives at the address in this manual.

Notes On Export Management

This product and its manuals may require an Export License/Approval by the Government of the product's country of origin for re-export from your country.

Before re-exporting the product or manuals, please contact us to confirm whether they are export-controlled items or not.

When you dispose of export-controlled items, the products/manuals are needed to be broken/shredded so as not to be unlawfully used for military purpose.

Trademark and Registered Trademark

Quick Basic is a registered trademark of Microsoft Corporation.

Composition of the MP1777A Operation Manual

The operation manual for the MP1777A 10 GHz Jitter Analyzer is composed of the two volumes shown below. Use the volume that suits the intended application of the product.

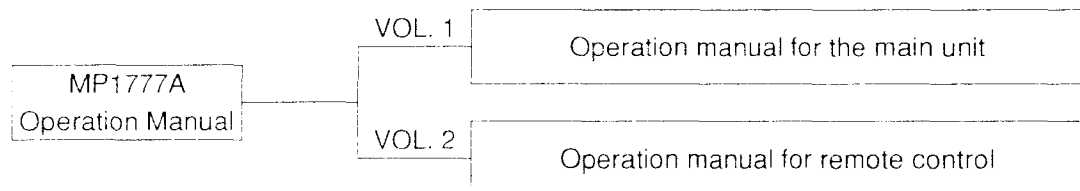

Operation manual for the main unit: This manual provides an outline of the MP1777A and its specifications, and describes its panel, performance and operation.

Operation manual for remote control: This manual describes remote control and provides program examples.

Table of Contents

For Safety	iii
Composition of the MP1777A Operation Manual ..	I
Section 1 Outline	1-1
1.1 Interface Function	1-2
1.2 System Setup Example	1-3
Section 2 GPIB Interface	2-1
2.1 GPIB Interface Functions	2-2
2.2 Device Message List	2-3
2.3 Bus Commands	2-4
2.4 Connecting the GPIB Cable	2-5
2.5 Setting GPIB	2-6
2.6 Initializing the Device	2-8
Section 3 Listener Input Format	3-1
3.1 Listener Input Program Message Format	3-2
3.2 Functional Elements of Program Message	3-4
3.3 Program Data Format	3-14
Section 4 Talker Output Format	4-1
4.1 Talker Output Response Message Format	4-2
4.2 Functional Elements of Response Message	4-3
Section 5 Common IEEE488.2 Commands	5-1
5.1 Common IEEE488.2	5-2

Section 6 Status Report 6-1

6.1 Configuration of MP1777A Status Registers 6-2
6.2 Status Registers Specified by IEEE488.2 6-4
6.3 Status Register Specified by SCPI 6-6
6.4 Status Register Specific to MP1777A 6-7
6.5 Reading, Writing and Clearing Status Registers 6-8

Section 7 SCPI Outline 7-1

7.1 Outline 7-2
7.2 Command Structure 7-3
7.3 Command Description Method 7-4
7.4 Compounding Commands 7-5
7.5 Parameter 7-6

Section 8 Device Message Details 8-1

8.1 Response Format 8-2
8.2 Buffer Size Stipulations 8-4
8.3 Device-Specific Commands 8-5

Appendix A SCPI Error Messages A-1

A.1 Command Errors A-2
A.2 Run Time Errors A-4
A.3 Device-Specific Errors A-5
A.4 Query Errors A-6

**Appendix B Details of Initialization Command
Functions B-1**

B.1 Initializing Bus B-2
B.2 Initializing Message B-3
B.3 Initializing Device B-4
B.4 Device Status at Power Activation B-5

Section 1 Outline

The MP1777A 10 GHz Jitter Analyzer enables automation of measurement when connected with an external controller. The GPIB interface is used for connection. This section provides explanations of interface functions and system setup examples.

1.1 Interface Function	1-2
1.2 System Setup Example	1-3

Section 1 Outline

1.1 Interface Function

The MP1777A has a connector for remote control on the back face.

Remote control of devices is enabled by fitting GPIB.

The GPIB setting is performed on the Secondary system screen in the Main setup screen.

GPIB interface: The GPIB interface for this device conforms to the IEEE (Institute of Electrical and Electronic Engineers) standards, 488.1-1987. The software conforms to the standards IEEE488.2 and SCPI (Standard Commands for Programmable Instruments). (See the Section 7 for more information.)

This device incorporates the following interface functions.

- Control of functions except for certain functions such as power source switch and Local key.
- Reading of all the setup conditions and screen display.

1.2 System Setup Example

The figure below shows an example of system setup using an interface.

Control from a host computer

When connected to a host computer, the device performs automatic measurement.

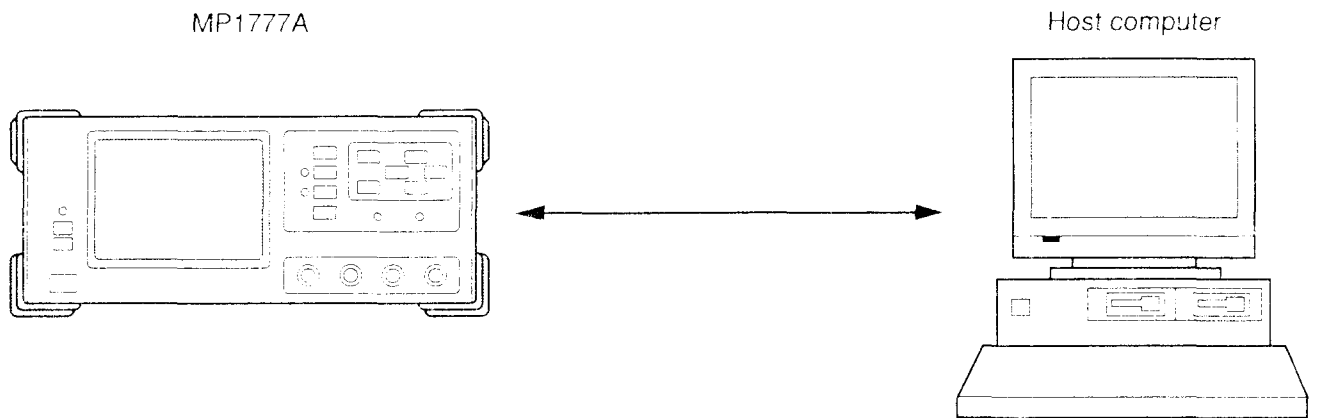

Fig. 1-1 Block Diagram

Section 1 Outline

Section 2 GPIB Interface

This section provides descriptions of the GPIB interface functions and setting method in the event that the GPIB interface is used as an option.

2.1	GPIB Interface Functions	2-2
2.2	Device Message List	2-3
2.3	Bus Commands	2-4
2.4	Connecting the GPIB Cable	2-5
2.5	Setting GPIB	2-6
2.6	Initializing the Device	2-8
2.6.1	Initializing the Bus	2-8
2.6.2	Initializing the Message	2-8
2.6.3	Initializing the Device	2-9
2.6.4	Device Status at Power Activation	2-9

Section 2 GPIB Interface

2.1 GPIB Interface Functions

This device only functions as a device and does not function as a controller. Accordingly, the GPIB interface has the following functions.

Table 2-1 GPIB Interface Functions

Cord	Interface Function	IEEE488.2 Standards
SH1	All the source handshake functions is available.	Incorporation of all the functions as the standard features
AH1	All the acceptor handshake functions is available.	Incorporation of all the functions as the standard features
T5	Basic talker functions is available. Serial port function is available. Talk only mode function is available. Talker cancellation function is by MLA available.	The device shall incorporate one of the following sub-sets: T5, T6, TE5 or TE6.
L4	Basic listener functions is available. No listen only mode function is available. Listener cancellation function is by MTA available.	The device shall incorporate one of the following sub-sets: L3, L4, LE3 or LE4.
SR1	All the service request functions is available.	Incorporation of all the functions as the standard features
RL1	All the remote and local functions is available.	RL0 (no functions) or RL1 (all functions)
PP0	No parallel port function is available.	PP0 (no functions) or PP1 (all functions)
DC1	All the device clear functions is available.	Incorporation of all the functions as the standard features
DT1	All the device trigger functions is available.	DT0 (no functions) or DT1 (all functions)
C0	No system controller functions is available.	C0 (no functions), C4 and C5, or one of the following sub-sets: C7, C9 or C11.

2.2 Device Message List

Device messages are data messages exchanged between the controller and the device via the system interface when the bus is set to the data mode (when the ATN line is set at "H"), and are classified into two types, the program messages and response messages.

The program messages are ASCII data messages transferred from the controller to the device, while the response messages are data messages transferred from the device to the controller.

Program and response messages are further classified into the following message types.

Table 2-2 Device Message List

Program Message (See the Section 4 for more information.)	Response Message (See the Section 5 for more information.)
Program instructions <ul style="list-style-type: none"> • Commands unique to the device (See the Section 7 for more information.) • Common IEEE488.2 commands (See the Section 5 "Status Report" for more information.) Program queries	Status messages (See the Section 6 "SCPI Outline" for more information.) Response messages

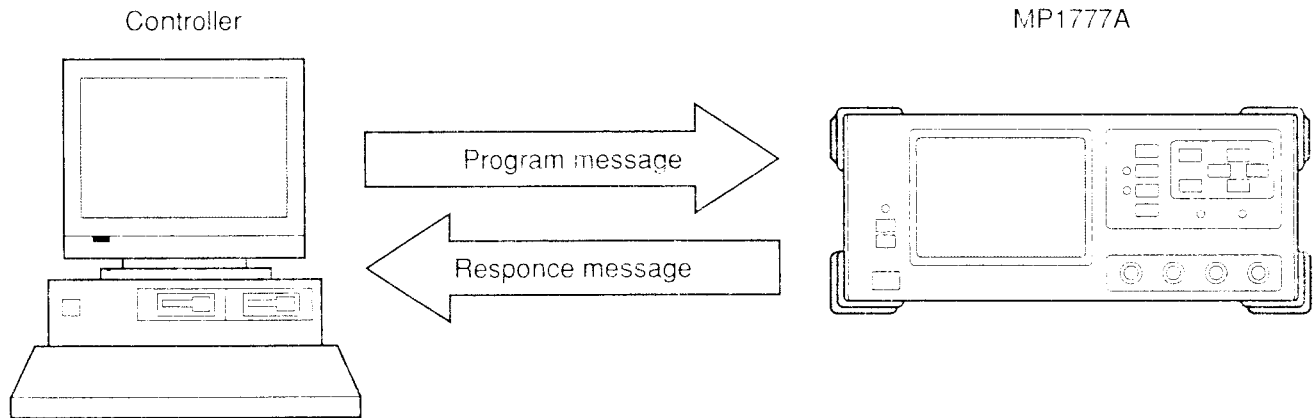

Fig. 2-1 Device Message

The messages mentioned above are exchanged through the I/O buffer of the device. The following section provides a brief description of the I/O buffer.

Table 2-3 I/O Buffer

Input Buffer	Output Queue
A FIFO (First In First Out) type memory area to temporarily store DAB (program messages and query messages) before they are syntactically analyzed. This device has an input buffer of 256 bytes in size.	A FIFO type memory area for the queue. All the DAB's (response messages) outputs from the device to the controller are stored in this memory until the controller finishes reading all the messages.

2.3 Bus Commands

Bus commands refer to internal interface communications exchanged when the bus is set to the command mode (when the ATM line is set at "L"). The table below shows a list of bus commands.

Table 2-4 Details of Bus Commands

Bus Command	Operations
DCL (Device clear)	Initializes the exchange of messages among all the devices connected to the GPIB bus.
SDC (Selected Device Clear)	Initializes the exchange of messages among addressed devices. The operations are the same as those for DCL.
GET (Group Execute Trigger)	Performs the same operations as those triggered when the Start/Stop key is pressed.
IFC (Interface Clear)	Initializes the interface.

2.4 Connecting the GPIB Cable

Connect the GPIB cable to the GPIB tangential line located on the back panel of this device. Systems using GPIB come under the following restrictions.

Follow the conditions set out below to connect devices.

- No. of devices enabled to be connected ≤ 15 units
- Total cable length $\leq 2 \text{ m} \times \text{number of devices (20 m maximum)}$

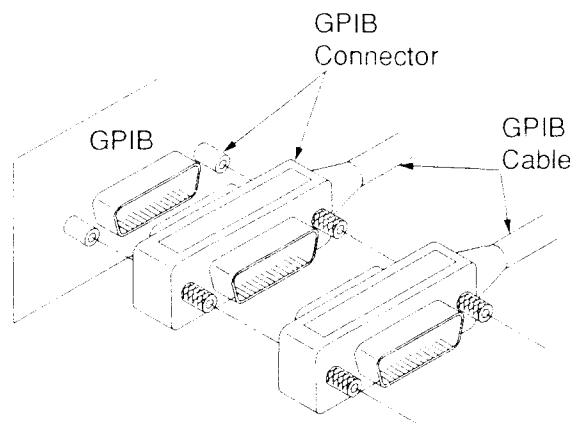

Fig. 2-2 Sketch of GPIB Cable

Section 2 GPIB Interface

2.5 Setting GPIB

To use GPIB as a remote interface, set the device to the local mode and set the address by performing key input on the front panel.

Table 2-5 Details of Setting when GPIB Interface is Used

Details of Setting	Setting Item	Setting Range
Address setting	Address	0 to 30

Perform the setting shown above on the Secondary system screen in the Main setup screen.

- (1) (a) Pressing the Setup key causes the Main setup screen to open.
The Main setup screen has "Setup" indicated on the left top section of the screen.

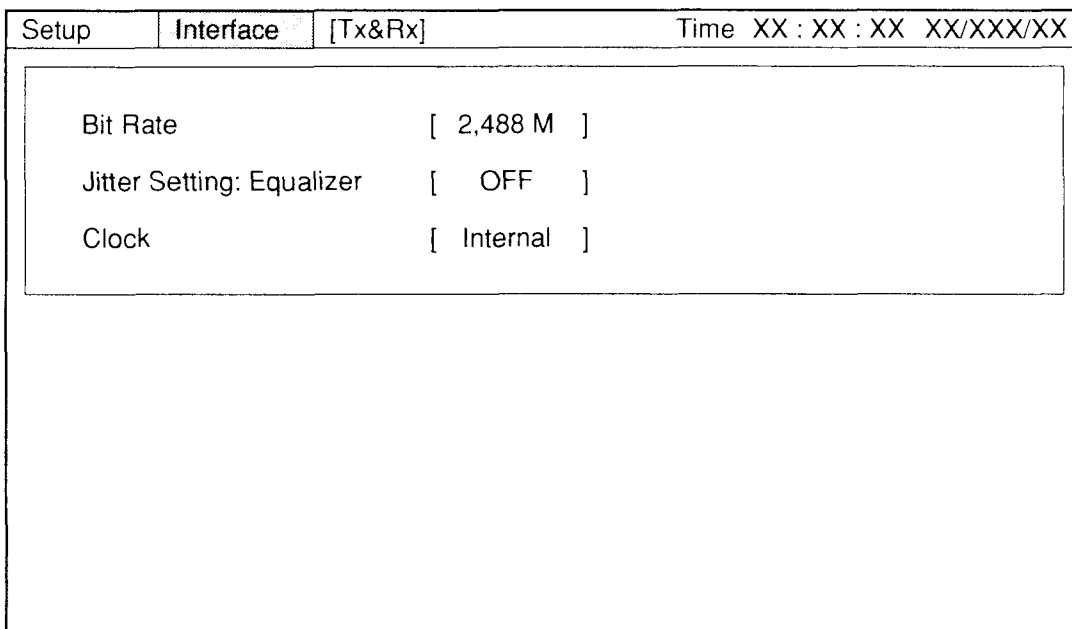

Fig. 2-3 Main setup Screen

- (b) Moving the cursor to the shaded section of the figure above and pressing the Setup key causes a window as shown below to open. To select the Secondary system screen, move the cursor onto "System" using the cursor key and press the Set key.

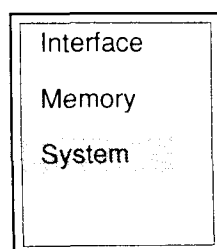

Fig. 2-4 Screen Selection Window

2.5 Setting GPIB

- (2) (a) Performing the operations mentioned in 1 causes the screen to shift to the Secondary system screen as shown below. Move the black and white reversing cursor to the position marked *1 and perform each setting. See the operation manual for the main unit for more information on setting.

Setup	System	Time	00 : 11 : 23	01/Jan/95
	Buzzer	[OFF]
	Date & Time adjust	[00 : 11 : 17	01/Jan/95]
*1 →	Address	[1]

Fig. 2-5 Secondary System Screen (When GPIB Interface is Used)

2.6 Initializing the Device

IEEE488.2 stipulates three levels of system initialization: initialization of the bus, message and device.

Table 2-6 Types of System Initialization

Level	Type of Initialization	Outline
1	Initialization of the bus	Initializes the functions of all the interfaces connected to the bus with the IFC message from the controller.
2	Initialization of the message	Disables the function to report to the controller that the initialization of the exchange of messages among all the devices on GPIB and relevant operations are completed by DCL, one of the GPIB bus commands, and that the initialization of the exchange of messages among specified devices on GPIB and relevant operations are completed by SCL, also one of the GPIB bus commands.
3	Initialization of the device	Returns the device to the original state unique to the device by *RST, regardless of the status during past usage.

2.6.1 Initializing the Bus

IFC: Initialization of the bus by the IFC statement

Function: Switches the IFC line into an active state for about 100 μ s and initializes the interface function of all the devices connected to the GPIB bus line. IFC can be transmitted only by the system controller.

2.6.2 Initializing the Message

DCL and SDC: Initialization of the exchange of messages by the DCL and SDC bus commands
Initializes the exchange of messages for all the devices on GPIB or specified devices on GPIB.

Functions: Initialization of the message exchange is aimed at setting preparations to enable the controller to send new instructions in the event that sections related to the message exchange in devices are set in a state inappropriate for the control to be executed from the controller because, for example, other programs were executed earlier, although changing the panel setting is not required.

DCL: Initializes the message exchange among all the devices on GPIB.

SDC: Initializes the message exchange among specified devices.

2.6.3 Initializing the Device

***RST:** Initialization of the device by the *RST command

Function: Returns the device function to the original state unique to the device, regardless of the status of past usage.
The original state in regard to this device refers to the state where the power source switch has been turned ON again.
(Descriptions are provided for the state of the device at power activation.)

2.6.4 Device Status at Power Activation

When the power is activated, the device switches into the following state :

- (1) State set when the power source was turned OFF the last time.
- (2) The input buffer and output queue are cleared.
- (3) The syntax analyzer, run time controller, and response production module are reset.

Section 2 GPIB Interface

Section 3 Listener Input Format

This section provides explanations of the format of the program message that the listener (this measuring instrument) receives from the talker (controller).

As the commands unique to the device conform to SCPI, the examples given in this section use SCPI commands.

3.1	Listener Input Program Message Format	3-2
3.2	Functional Elements of Program Message	3-4
3.2.1	<TERMINATED PROGRAM MESSAGE>	3-4
3.2.2	<PROGRAM MESSAGE TERMINATOR>	3-5
3.2.3	<white space>	3-5
3.2.4	<PROGRAM MESSAGE>	3-6
3.2.5	<PROGRAM MESSAGE UNIT SEPARATOR>	3-7
3.2.6	<PROGRAM MESSAGE UNIT>	3-7
3.2.7	<COMMAND MESSAGE UNIT> and <QUERY MESSAGE UNIT>	3-8
3.2.8	<COMMAND PROGRAM HEADER>	3-10
3.2.9	<QUERY PROGRAM HEADER>	3-12
3.2.10	<PROGRAM HEADER SEPARATOR>	3-13
3.2.11	<PROGRAM DATA SEPARATOR>	3-13
3.3	Program Data Format	3-14
3.3.1	<CHARACTER PROGRAM DATA>	3-15
3.3.2	<DECIMAL NUMERIC PROGRAM DATA>	3-16
3.3.3	<BOOLEAN PROGRAM DATA>	3-17
3.3.4	<STRING PROGRAM DATA>	3-17

Section 3 Listener Input Format

3.1 Listener Input Program Message Format

The following section shows program messages when, for example, 4 UI is selected for the reception jitter and the reception signal is set to 9953M.

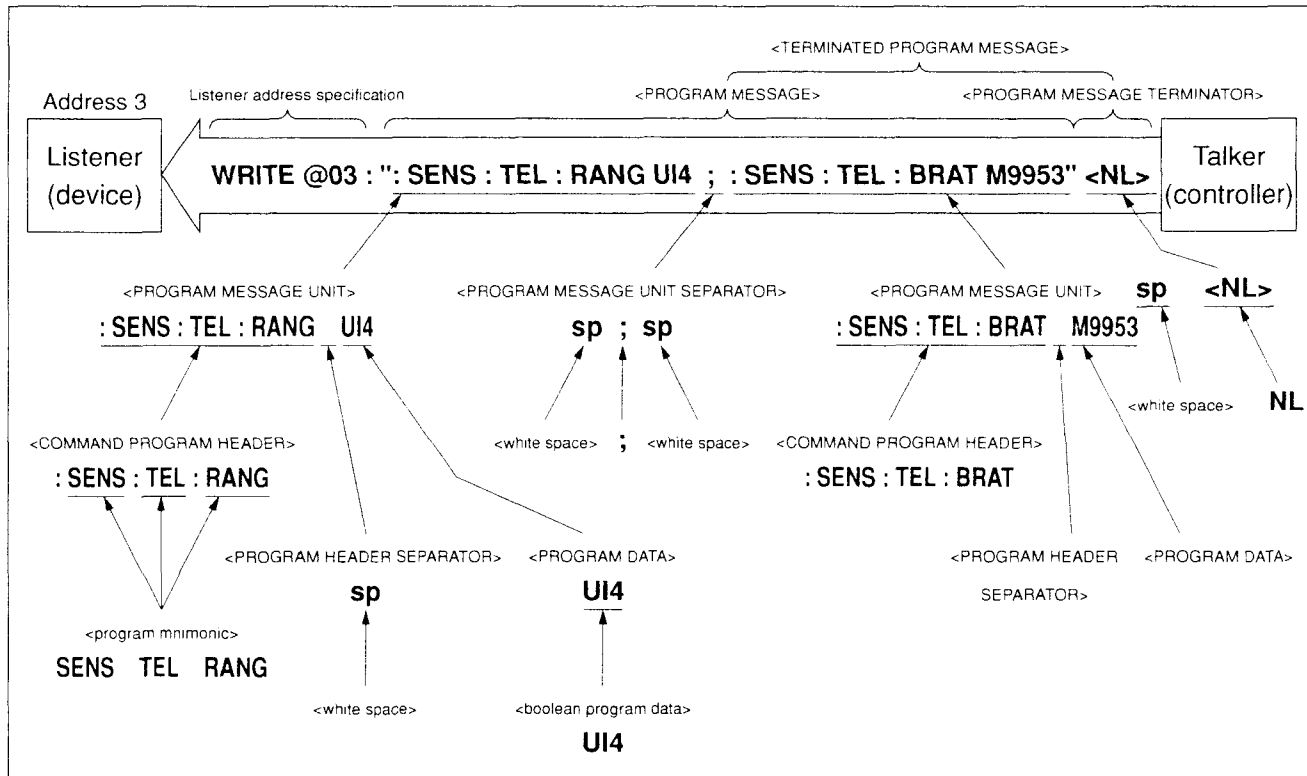

The program message format comprises a sequence of functional elements divided into the units of minimum level to express functions. The uppercase letters in angled brackets (< and >) in the figure above show examples of functional elements. The functional elements are further divided into elements called the coding elements. The lowercase letters in angled brackets (< and >) in the figure above show examples of coding elements.

The following pages provide explanations of the program message format using the functional syntax diagram and coding syntax diagram.

- Functional syntax diagram: Graphic representation of selection of functional elements along specific routes
- Coding syntax diagram: Graphic representation of selection of coding elements along specific routes

3.1 Listener Input Program Message Format

The WRITE and READ commands take the following formats.

WRITE @

Outputs data to the device.

■ Format

WRITE @	Device number :	Data
Data →	Arithmetic expression	
	Character string expression	

<Example> The same as the example given on the previous page.

WRITE @03 : " : SENS : TEL : RANG UI4 ; : SENS : TEL : BRAT M9953"

Listener address

(in case that the GPIB address of the 10 GHz Jitter Analyzer is set at 3)

READ @

Substitutes the data input from the device to the variable.

■ Format

READ @Device number : Variable

<Example> Substitutes the data input from the device (input tangential line setting) to the variable, A\$.

WRITE @03 : " : SENS : TEL : RANG?" ← Inquires about the input tangential line setting.

READ @03 : A\$

Listener address

(in case that the GPIB address of the 10 GHz Jitter Analyzer is set at 3)

Section 3 Listener Input Format

3.2 Functional Elements of Program Message

This measuring instrument accepts the program message by detecting the terminator located at the end of the program message. The following section explains each functional element of the program message.

3.2.1 <TERMINATED PROGRAM MESSAGE>

The <TERMINATED PROGRAM MESSAGE> is defined as follows.

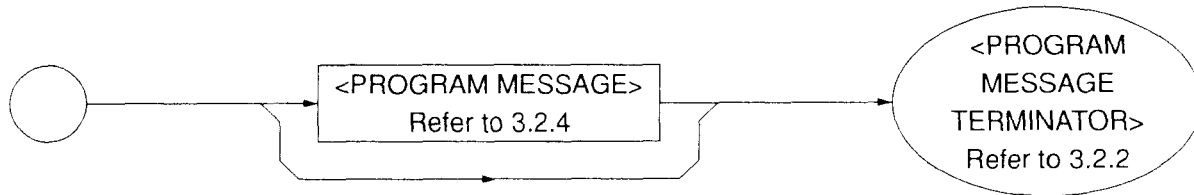

The <TERMINATED PROGRAM MESSAGE> constitutes a data message that incorporates all the functional elements necessary for the controller to send data to this measuring instrument.

To complete the transfer of the <PROGRAM MESSAGE>, the <PROGRAM MESSAGE TERMINATOR> is added to the end of the <PROGRAM MESSAGE>.

Example: <TERMINATED PROGRAM MESSAGE> to send two instructions

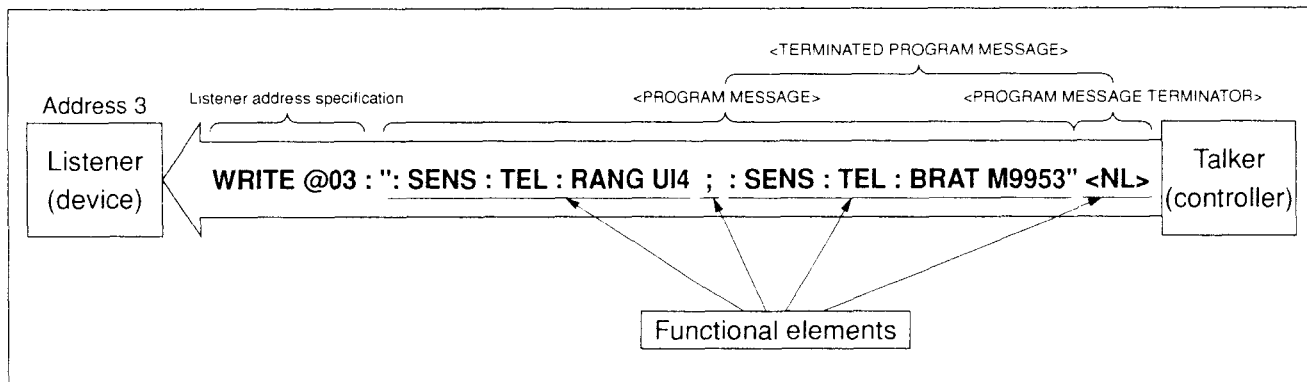

3.2.2 <PROGRAM MESSAGE TERMINATOR>

The <PROGRAM MESSAGE TERMINATOR> in the case of using the GPIB interface is defined as follows.

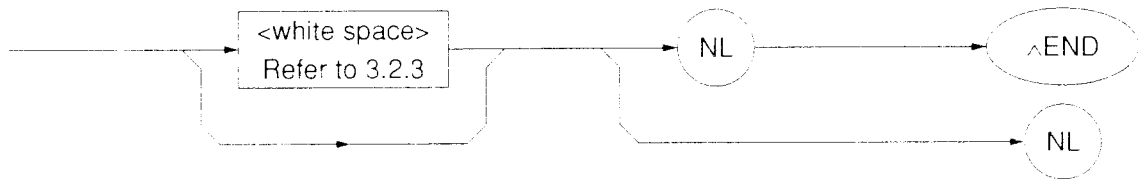

The <PROGRAM MESSAGE TERMINATOR> ends a sequence of one or multiple <PROGRAM MESSAGE UNIT> elements of certain length.

- NL:** Defined as a single ASCII code byte 0A (10 of decimal digit). Namely, this constitutes an ASCII control character LF (Line Feed) and performs the new line operations to return the printing position to the same character position on the next line. As this causes printing to start from a new line, it is also called the NL (New Line).
- END:** Generates the EOI signal by setting the EOI (End-or-Identify) line, which is one of the GPIB control buses, to TRUE (the LOW level).
The statements to control the EOI line includes the EOI ON/OFF statement.

3.2.3 <white space>

The <white space> is defined as follows.

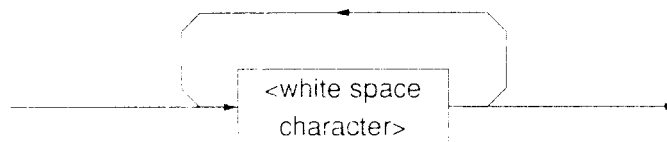

The <white space character> is defined as the single ASCII code byte in the ranges of ASCII code bytes of between 00 and 09 and between 0B to 20 (decimal digits, 0 to 9 and 11 to 32).

The ASCII control symbol and blank symbol with an exception of the New Line are included in the range. However, this measuring instrument does not interpret them as ASCII control symbols but simply processes them as space or skips reading them.

Section 3 Listener Input Format

3.2.4 <PROGRAM MESSAGE>

The <PROGRAM MESSAGE> is defined as follows.

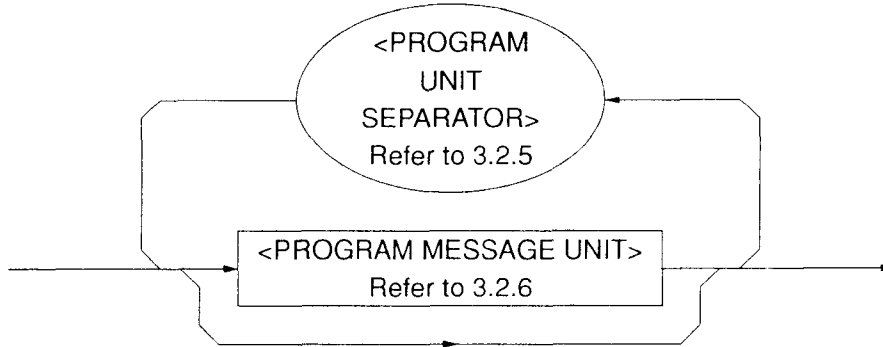

The <PROGRAM MESSAGE> is composed of a sequence of zero, one or multiple <PROGRAM MESSAGE UNIT> elements.

The <PROGRAM MESSAGE UNIT> elements signify programming instructions or data to be sent from the controller to this measuring instrument. The <PROGRAM MESSAGE UNIT SEPARATOR> is used as the separator for delimiting multiple <PROGRAM MESSAGE UNIT> elements.

Example: Selects the reception jitter range of 4 UI and sets the reception signal to 9953M.

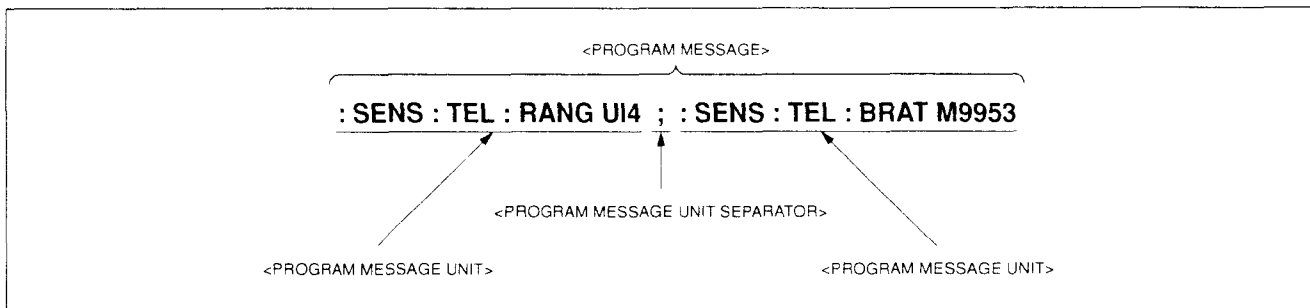

3.2.5 <PROGRAM MESSAGE UNIT SEPARATOR>

The <PROGRAM MESSAGE UNIT SEPARATOR> is defined as follows.

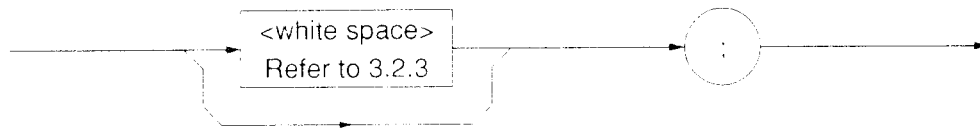

The <white space> is defined as follows.

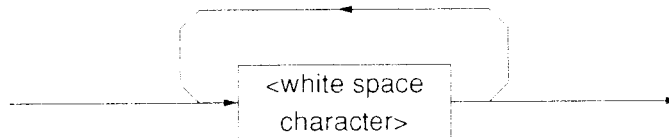

The <PROGRAM MESSAGE UNIT SEPARATOR> divides a sequence of multiple <PROGRAM MESSAGE UNIT> elements within the range of the <PROGRAM MESSAGE>.

This measuring instrument interprets a semicolon (;) as the separator for the <PROGRAM MESSAGE UNIT>.

Therefore, the <white space character> located before and after the semicolon (;) is skipped.

Nonetheless, the <white space character> is effective in facilitating the reading of the program.

3.2.6 <PROGRAM MESSAGE UNIT>

The <PROGRAM MESSAGE UNIT> is defined as follows.

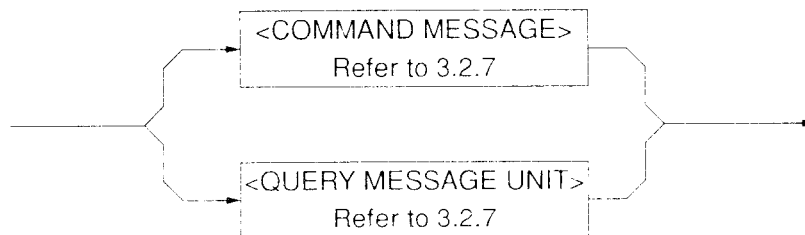

The <PROGRAM MESSAGE UNIT> comprises the <COMMAND MESSAGE UNIT>, which constitutes a single command message received by this measuring instrument, or <QUERY MESSAGE UNIT>, which constitutes a single query message.

Section 3 Listener Input Format

3.2.7 <COMMAND MESSAGE UNIT> and <QUERY MESSAGE UNIT>

(1) The <COMMAND MESSAGE UNIT> is defined as follows.

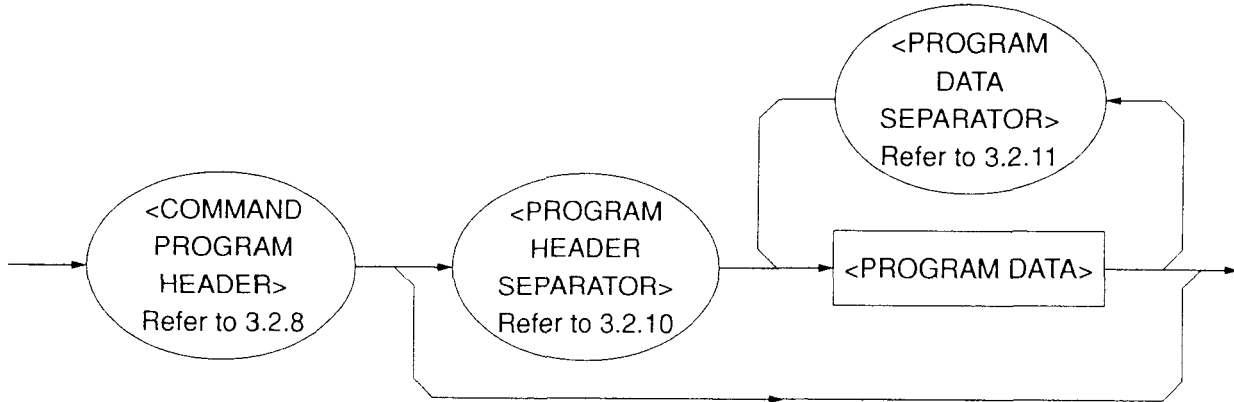

Example: Sets the data.

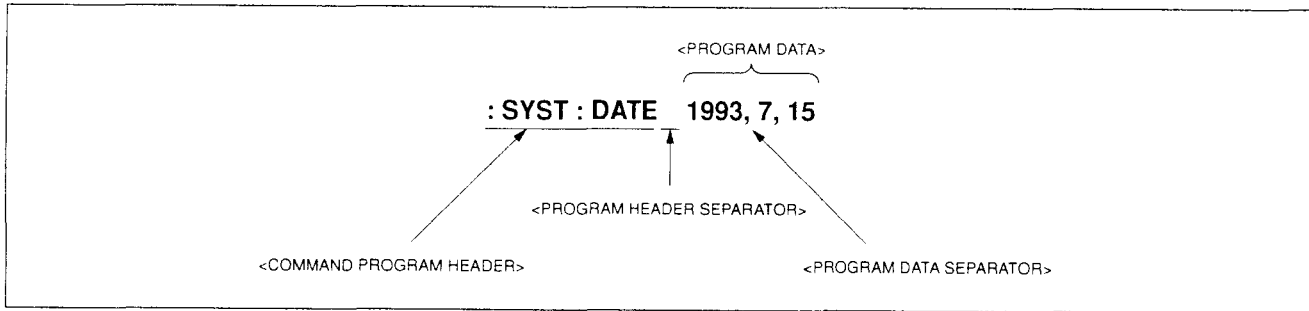

3.2 Functional Elements of Program Message

(2) The <QUERY MESSAGE UNIT> is defined as follows.

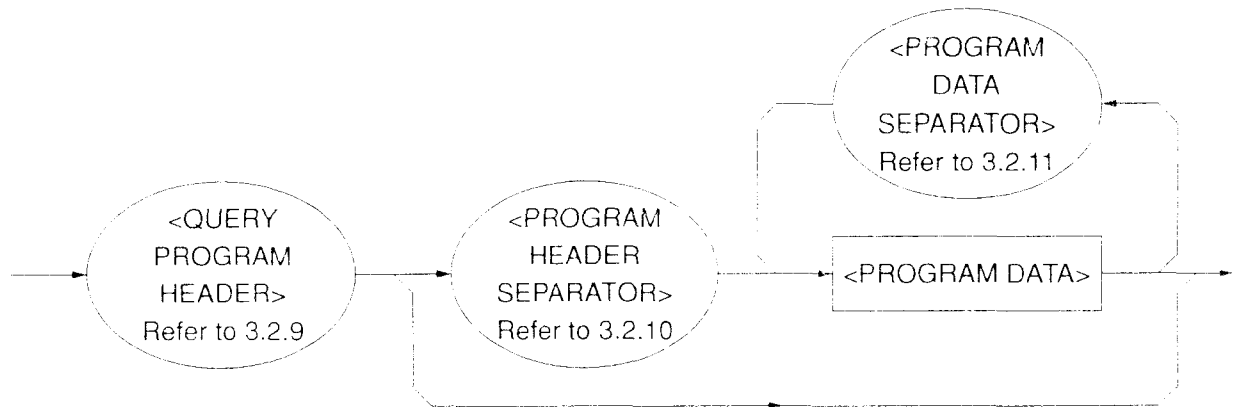

Example: Inquires about the analyzed data of the error or alarm.

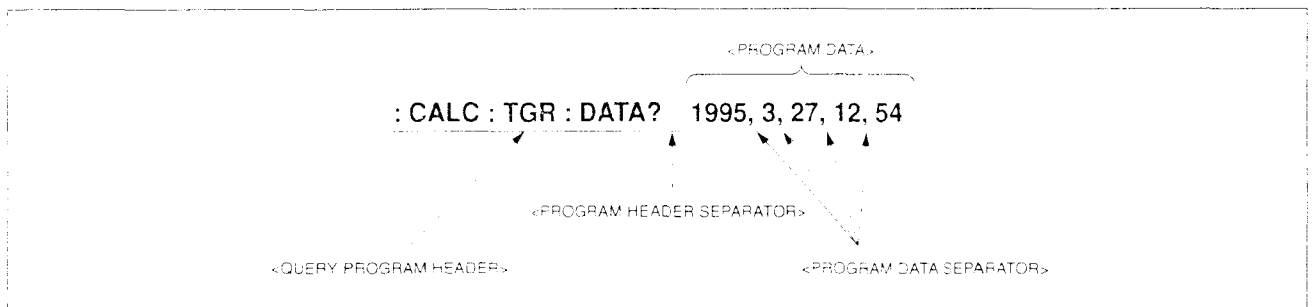

When the program data follows the program header of <COMMAND MESSAGE UNIT> and <QUERY MESSAGE UNIT>, a space character is always entered between them as a separator. The program application, function and operation can be identified by the program header. In the absence of the program data to follow the program header, the program header alone expresses the application, function and operation to be executed in this measuring instrument.

The <COMMAND PROGRAM HEADER> in the program header functions as a command to be used by the controller to control this measuring instrument, while the <QUERY PROGRAM HEADER> is a query command that the controller preliminarily sends to this measuring instrument so that the controller will be able to receive the response message from this measuring instrument. It is always characterized by the addition of the query indicator, or a question mark (?), to the end of the header.

Section 3 Listener Input Format

3.2.8 <COMMAND PROGRAM HEADER>

The <COMMAND PROGRAM HEADER> is defined as follows.

The <while space> can be placed before each header.

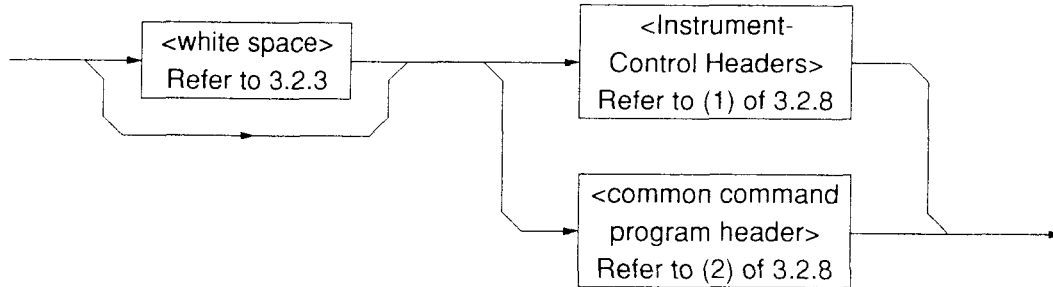

(1) The <Instrument-Control Headers> are defined as follows.

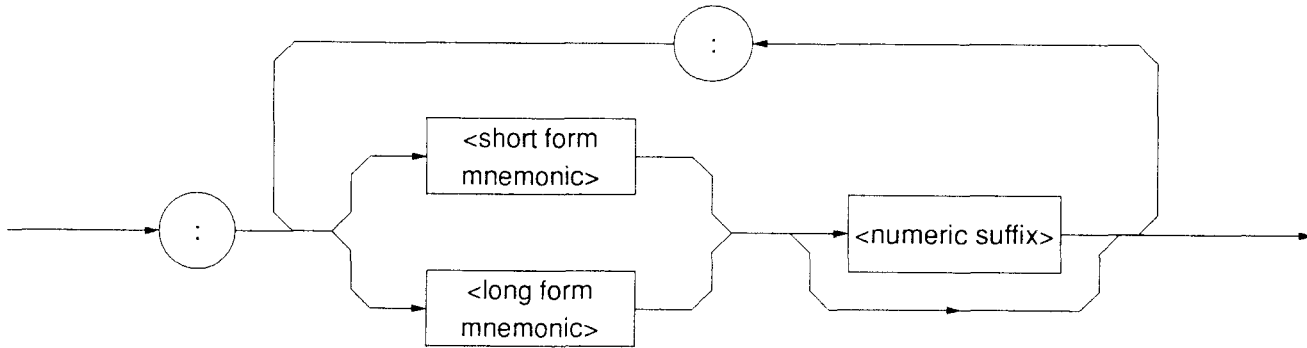

(2) The <common command program header> is defined as follows.



(3) The <program mnemonic> is defined as follows.

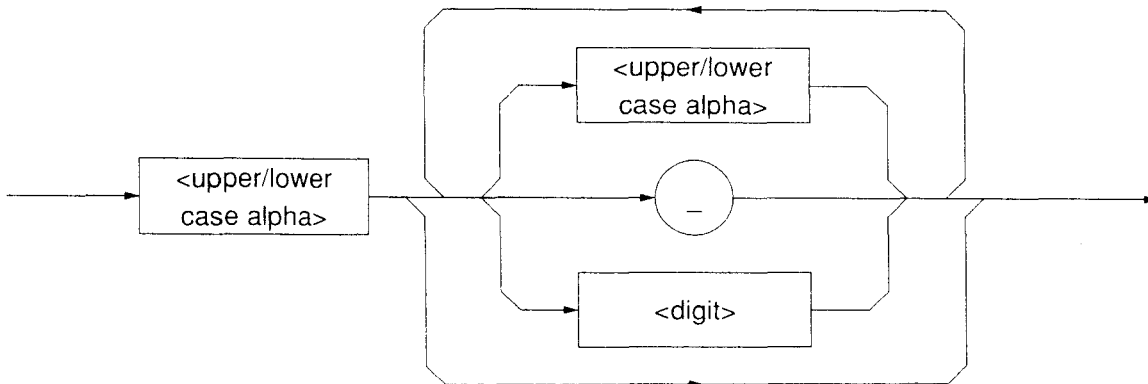

3.2.8.1 <COMMAND PROGRAM HEADER>

The <COMMAND PROGRAM HEADER> expresses the application, function and operation of the program data to be executed by this measuring instrument. In the absence of the program data to follow the command program header, the command program header alone expresses the application, function and operation to be executed in this measuring instrument.

The <program mnemonic> expresses these meanings by ASCII code characters, and is generally called the mnemonic.

3.2.8.2 <program mnemonic>

The header of the mnemonic always begins with an uppercase or lowercase character. Then, it is followed by an arbitrary combination of uppercase characters (A to Z), lowercase characters (a to z), an underline (_), and digits from 0 to 9. The mnemonic comes in a maximum length of 12 characters, with no space inserted between characters.

(1) <upper/lower case alpha>

Specified as a single ASCII code byte in the range of ASCII code bytes between 41 and 5A, and 61 and 7A (65 to 90 and 97 to 122 of decimal digits = uppercase characters (A to Z) and lowercase characters (a to z)).

(2) <digit>

Specified as a single ASCII code byte in the range of ASCII code bytes between 30 and 39 (48 to 57 of decimal digits = numerical values between 0 and 9).

(3) (_)

Specified as a single ASCII code byte in the range of ASCII code byte of 5F (95 of decimal digit = underline).

3.2.8.3 <Instrument-Control Headers>

The <Instrument-Control Headers> are specified by SCPI. As the device-specific commands of this measuring instrument conform to SCPI, the command format used is that of this programming language.

(1) <short form mnemonic> and <long form mnemonic>

Corresponds to the short form and long form of the SCPI commands. The stipulations of <program mnemonic> mentioned above apply as they are as the mnemonic stipulations.

(2) <numeric suffix>

Specified as a single ASCII code byte in the range of ASCII code bytes between 30 and 39 (48 to 57 of decimal digit = numerical values between 0 and 9).

3.2.8.4 <common command program header>

The <common command program header> always has an asterisk (*) before the <program mnemonic>.

Section 3 Listener Input Format

3.2.9 <QUERY PROGRAM HEADER>

The <QUERY PROGRAM HEADER> is defined as follows.

The <white space> can be placed before each header.

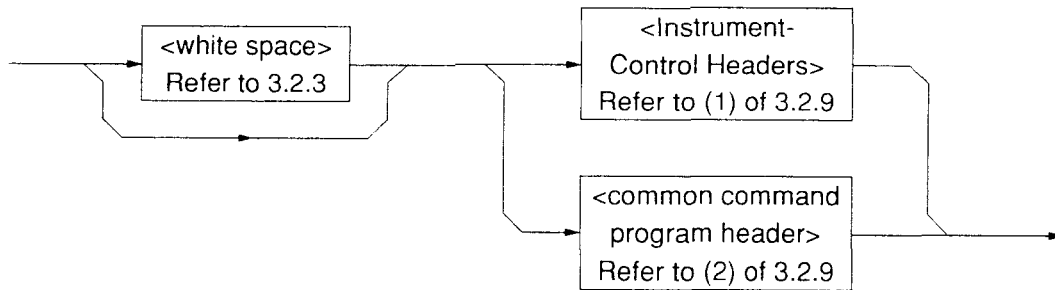

(1) The <Instrument-Control Headers> are defined as follows.

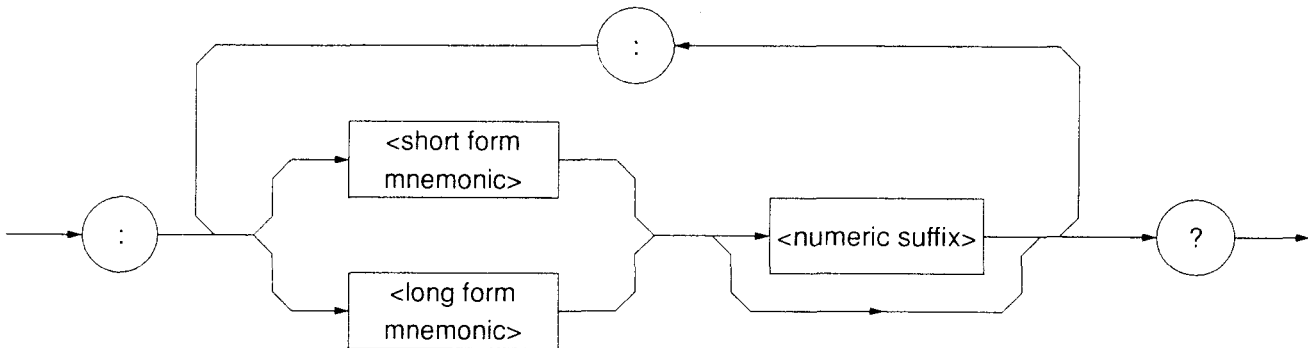

(2) The <common query program header> is defined as follows.

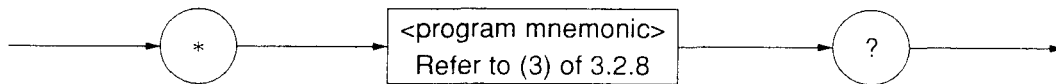

3.2.9.1 <QUERY PROGRAM HEADER>

The <QUERY PROGRAM HEADER> is a query command, that the controller preliminarily sends to this measuring instrument so that the controller will be able to receive the response message from this measuring instrument.

It is always characterized by the addition of the query indicator, or a question mark (?), to the end of the header.

The <QUERY PROGRAM HEADER> format mentioned above comes with the query indicator, or a question mark (?), added to the end of the header

As other features are the same as those for the <COMMAND PROGRAM HEADER>, see the Section 3.2.8 "<COMMAND PROGRAM HEADER>" for more information.

3.2.10 <PROGRAM HEADER SEPARATOR>

The <PROGRAM HEADER SEPARATOR> is defined as follows.

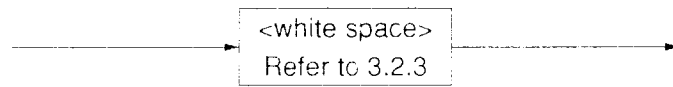

The <PROGRAM HEADER SEPARATOR> is used as a separator between the <COMMAND PROGRAM HEADER> or <QUERY PROGRAM HEADER> and <PROGRAM DATA>. When multiple <white space characters> are found between the program header and program data, the first <white space character> is interpreted as the separator, and other <white space characters> are skipped.

Nonetheless, the <white space character> is effective in facilitating reading of the program.

This means that only one header separator is always found between the header and data to signal the end of the program as well as the beginning of the program data.

3.2.11 <PROGRAM DATA SEPARATOR>

The <PROGRAM DATA SEPARATOR> is defined as follows.

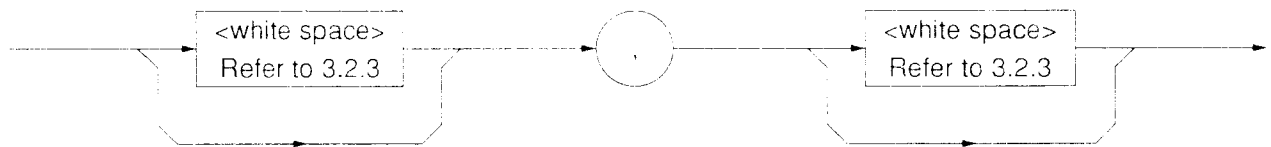

When the <COMMAND PROGRAM HEADER> or <QUERY PROGRAM HEADER> has multiple parameters, the <PROGRAM DATA SEPARATOR> is used to separate these parameters.

When this data separator is used, a comma (,) is always necessary but the <white space character> is not necessarily required. The <white space character> located before or after a comma (,) will be skipped. However, the <white space character> is effective in facilitating reading of the program.

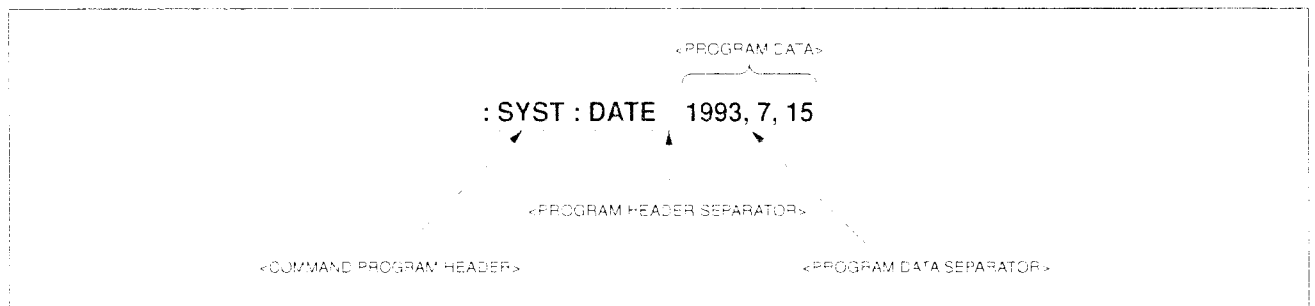

3.3 Program Data Format

This section provides explanations of the format of <PROGRAM DATA> illustrated by the functional syntax diagram of the Section 3.2.7 "<COMMAND MESSAGE UNIT> and <QUERY MESSAGE UNIT>" from among formats of program messages terminated as mentioned in the earlier sections.

The functional elements of <PROGRAM DATA> are used to transfer parameters of various types related to the program header. The sections shaded in the figure below are the program data used by this measuring instrument.

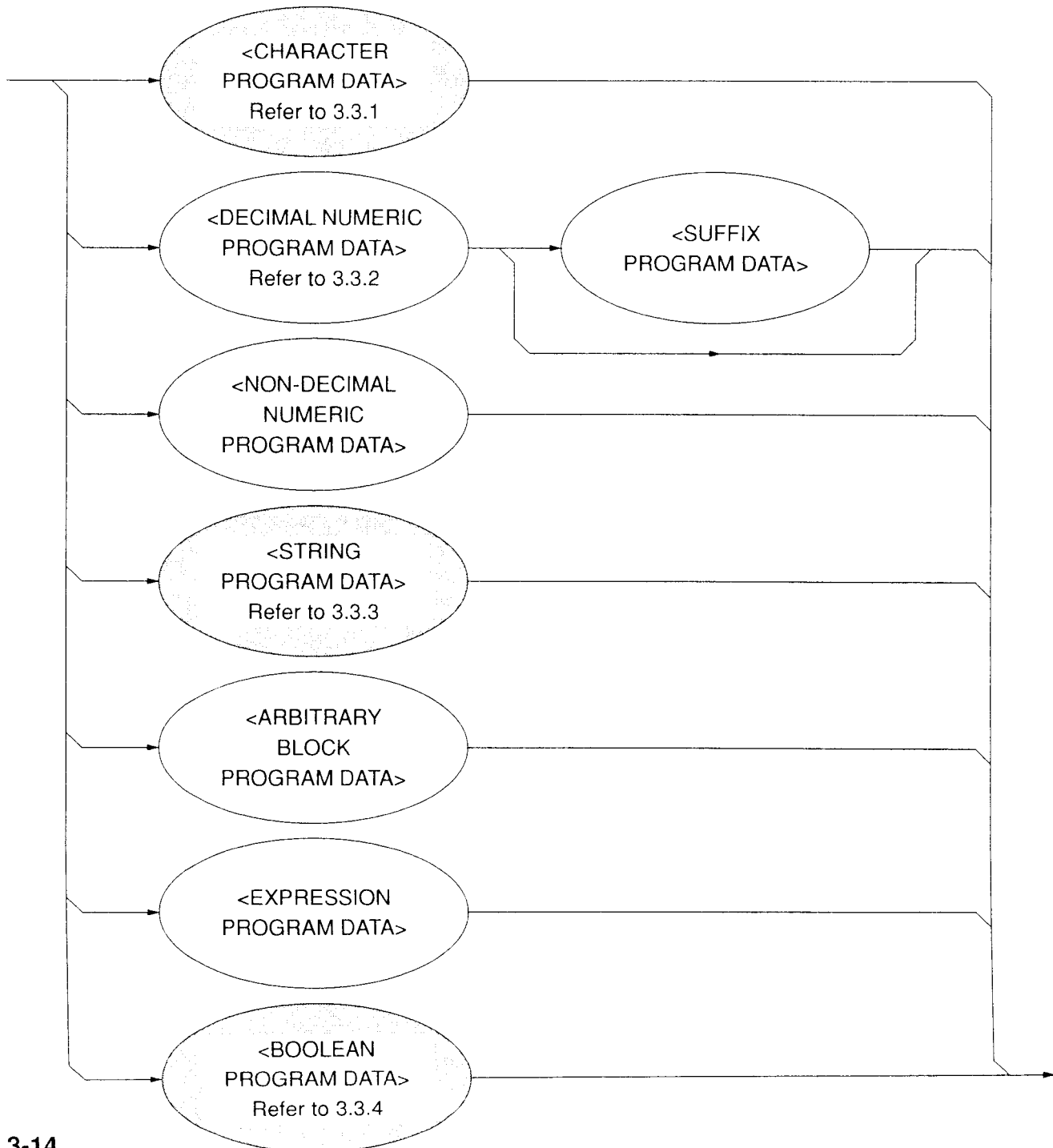

3.3.1 <CHARACTER PROGRAM DATA>

The <CHARACTER PROGRAM DATA> expresses a short mnemonic data and is defined as follows.

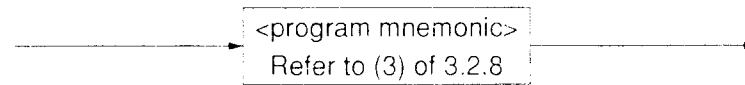

: SENSE : MEASURE : TYPE SINGLE (Mnemonic data to express single measurement)

Section 3 Listener Input Format

3.3.2 <DECIMAL NUMERIC PROGRAM DATA>

The <DECIMAL NUMERIC PROGRAM DATA> expresses a numeric value of a decimal digit and is defined as follows.

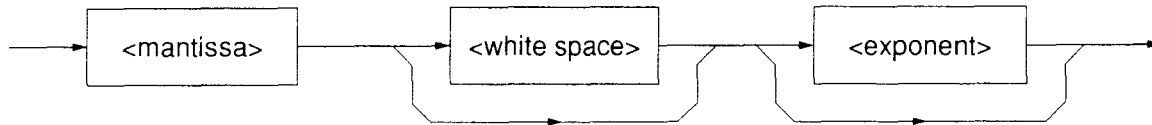

(1) The <mantissa> is defined as follows.

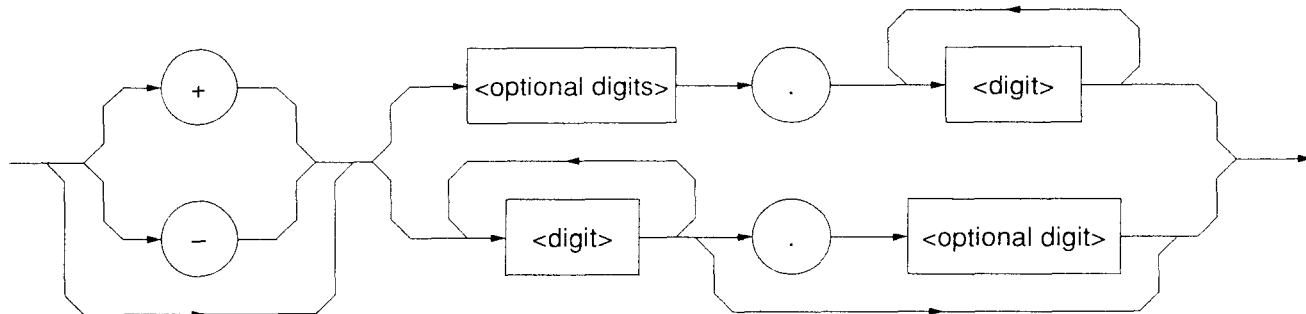

(2) The <exponent> is defined as follows.

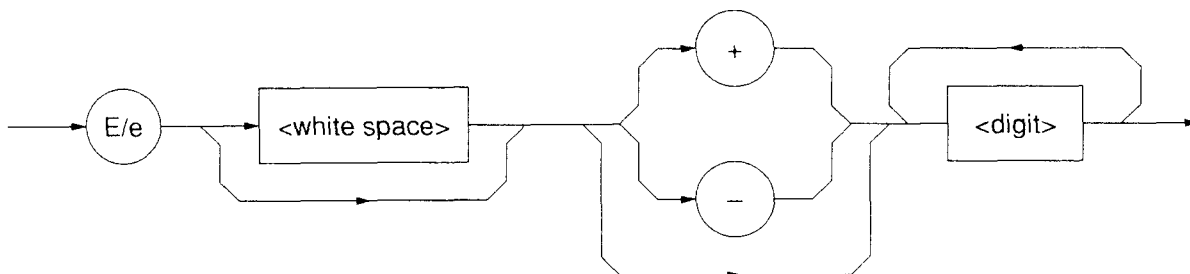

This measuring instrument uses the integer type of decimal digits.

Integer type

Expresses the integer values of decimal digits. The underline (_) stands for a space.

- Zero (0) enabled to be input at the header 005
- Space between a sign and digit disabled +5 (good), +_5 (no good)
- Space enabled to be inserted to follow a numeric value +5_ _
- The plus sign can be either added or omitted +5, 5
- A comma disabled to be used to separate digits 1,234 (no good)

3.3.3 <BOOLEAN PROGRAM DATA>

The <BOOLEAN PROGRAM DATA> refers to the program data specified by SCPI and expresses a theoretical value. As values to correspond to the truth and falsity, ON and OFF of the <CHARACTER PROGRAM DATA> and 1 and 0 of the <DECIMAL NUMERIC PROGRAM DATA> are defined.

```
: SOURce: TELecom: Jitter ON
: SOURce: TELecom: Jitter 1
```

3.3.4 <STRING PROGRAM DATA>

The <STRING PROGRAM DATA> expresses a character string in double quotations (") or single quotations (') and is defined as follows.

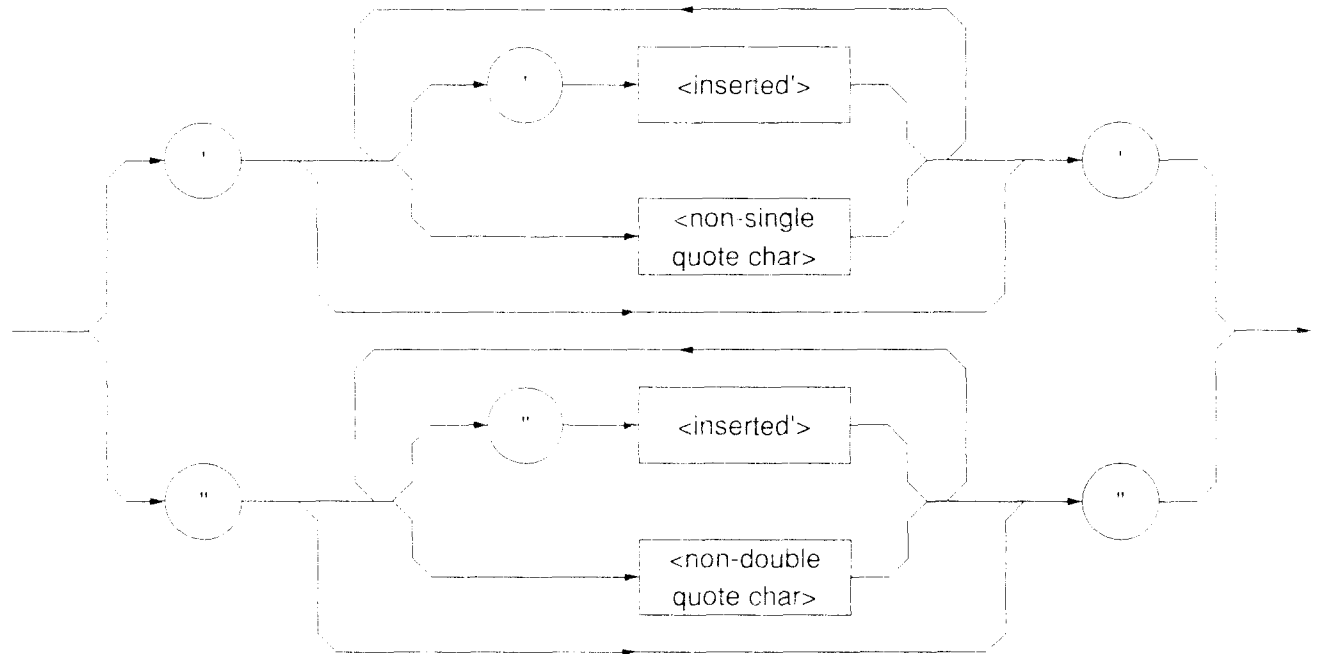

- (1) <inserted'> is specified by a single ASCII sign of value 27 (39 of decimal digit = ').
- (2) <non-single quote char> is specified by a single ASCII sign of a value other than 27 (39 of decimal digit = ').
- (3) <inserted'> is specified by a single ASCII sign of value 22 (34 of decimal digit = ").
- (4) <non-double quote char> is specified by a single ASCII sign of a value other than 22 (34 of decimal digit = ").

Section 3 Listener Input Format

Section 4 Talker Output Format

This section provides explanations of the format of the response messages to be returned from the talker (device) to the listener (controller).

4.1	Talker Output Response Message Format	4-2
4.2	Functional Elements of Response Message	4-3
4.2.1	<TERMINATED RESPONSE MESSAGE>	4-3
4.2.2	<RESPONSE MESSAGE TERMINATOR>	4-3
4.2.3	<RESPONSE MESSAGE>	4-4
4.2.4	<RESPONSE MESSAGE UNIT SEPARATOR>	4-4
4.2.5	<RESPONSE MESSAGE UNIT>	4-5
4.2.6	<RESPONSE DATA SEPARATOR>	4-5
4.2.7	<RESPONSE DATA>	4-6

Section 4 Talker Output Format

4.1 Talker Output Response Message Format

The figure below shows responses to the query for the selection of the receiving jitter range, : SENS : TEL : RANG?, and to the query for the sign speed of the received signal, : SENS : TEL : BRAT?.

As the SCPI response has no header, the response only consists of data.

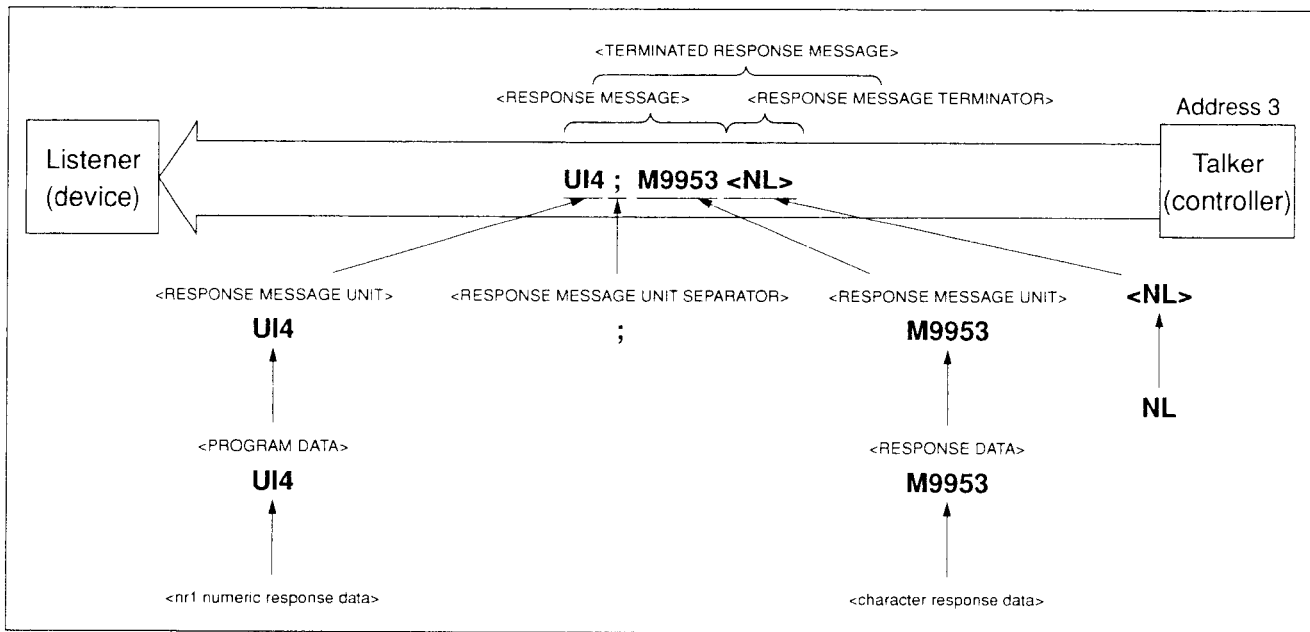

Like the program message, the response message format comprises a sequence of functional elements divided into the units of minimum level to express functions. The uppercase letters in angled brackets (< and >) in the figure above show examples of functional elements. The functional elements are further divided into elements called the coding elements. The lowercase letters in angled brackets (< and >) in the same figure above show examples of coding elements. Accordingly, the same syntactical notational convention is used for the talker and the listener.

4.2 Functional Elements of Response Message

4.2.1 <TERMINATED RESPONSE MESSAGE>

The <TERMINATED RESPONSE MESSAGE> is defined as follows.



The <TERMINATED PROGRAM MESSAGE> constitutes a data message that incorporates all the functional elements necessary for the talker device to send data to the controller.

To complete the transfer of the <REPOSEN MESSAGE>, the <REPOSEN MESSAGE TERMINATOR> is added to the end of the <REPOSEN MESSAGE>.

Example: <TERMINATED REPOSEN MESSAGE> concatenating two message units

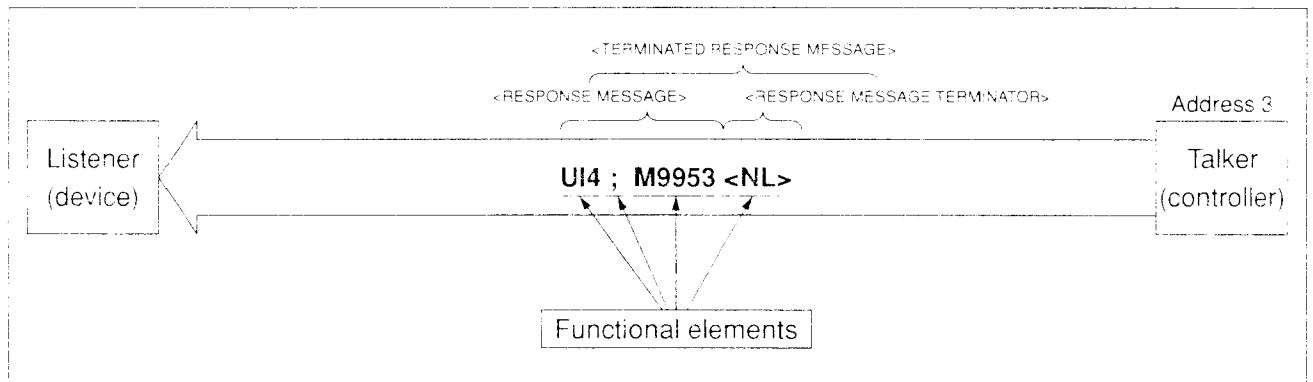

4.2.2 <RESPONSE MESSAGE TERMINATOR>

(1) The <RESPONSE MESSAGE TERMINATOR> in case the GPIB interface is used is defined as follows.



The <RESPONSE MESSAGE TERMINATOR> comes after the last <RESPONSE MESSAGE UNIT>, and ends a sequence of one or multiple <RESPONSE MESSAGE UNIT> elements of a certain length.

Example: Indicates an example of the program to read the state of receiving jitter range currently set.

```

10 WRITE @03 : ": SENS : TEL : RANG?"
20 READ @03 : A$
30 PRINT A$
40 END
  
```

Section 4 Talker Output Format

4.2.3 <RESPONSE MESSAGE>

The <RESPONSE MESSAGE> is defined as follows.

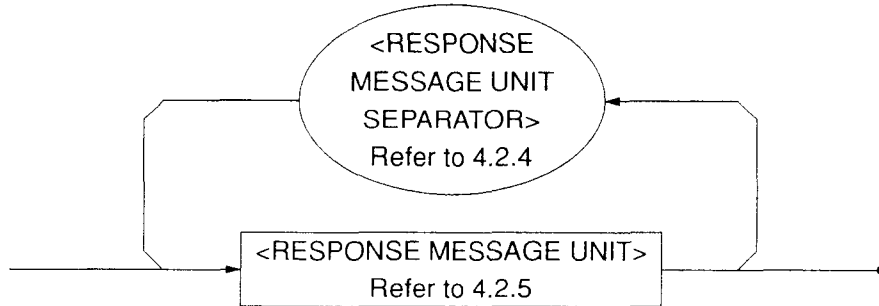

The <RESPONSE MESSAGE> is composed of a sequence of one or multiple <RESPONSE MESSAGE UNIT> elements

The <RESPONSE MESSAGE UNIT> element signifies a single message to be sent from this measuring instrument to the controller. The <RESPONSE MESSAGE UNIT SEPARATOR> element is used as the separator to delimit multiple <RESPONSE MESSAGE UNIT> elements.

Example:

Indicates responses to queries for the selection of receiving jitter range and for the setting of sign speed of received signal.

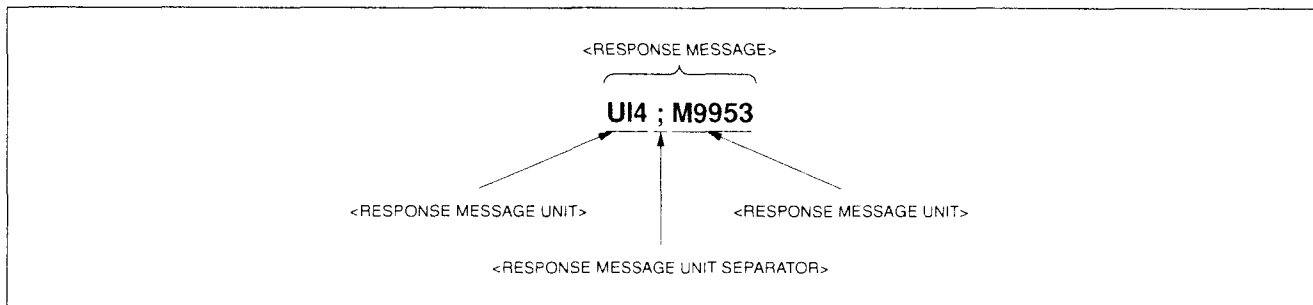

4.2.4 <RESPONSE MESSAGE UNIT SEPARATOR>

The <RESPONSE MESSAGE UNIT SEPARATOR> is defined as follows.



The <RESPONSE MESSAGE SEPARATOR> separates with a semicolon (;) that constitutes the <UNIT SEPARATOR>, the <RESPONSE MESSAGE UNIT> elements when a sequence of multiple <RESPONSE MESSAGE UNIT> elements is output as one <RESPONSE MESSAGE>.

4.2.5 <RESPONSE MESSAGE UNIT>

The <RESPONSE MESSAGE UNIT> is defined as follows.

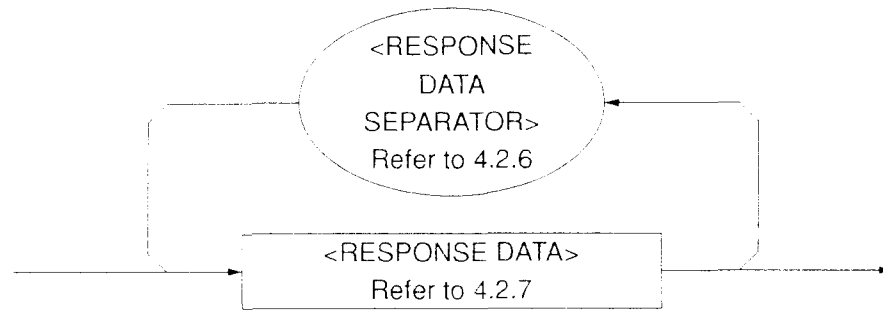

The <RESPONSE MESSAGE UNIT> of this measuring instrument is a response message unit with no header and only returns data of measured results.

4.2.6 <RESPONSE DATA SEPARATOR>

The <RESPONSE DATA SEPARATOR> is defined as follows.



The <RESPONSE DATA SEPARATOR> is used to separate data when multiple <RESPONSE DATA> are output.

Section 4 Talker Output Format

4.2.7 <RESPONSE DATA>

The shaded sections in the figure below refer to the <RESPONSE DATA> used by this measuring instrument
The response data to be returned depends on the query message.

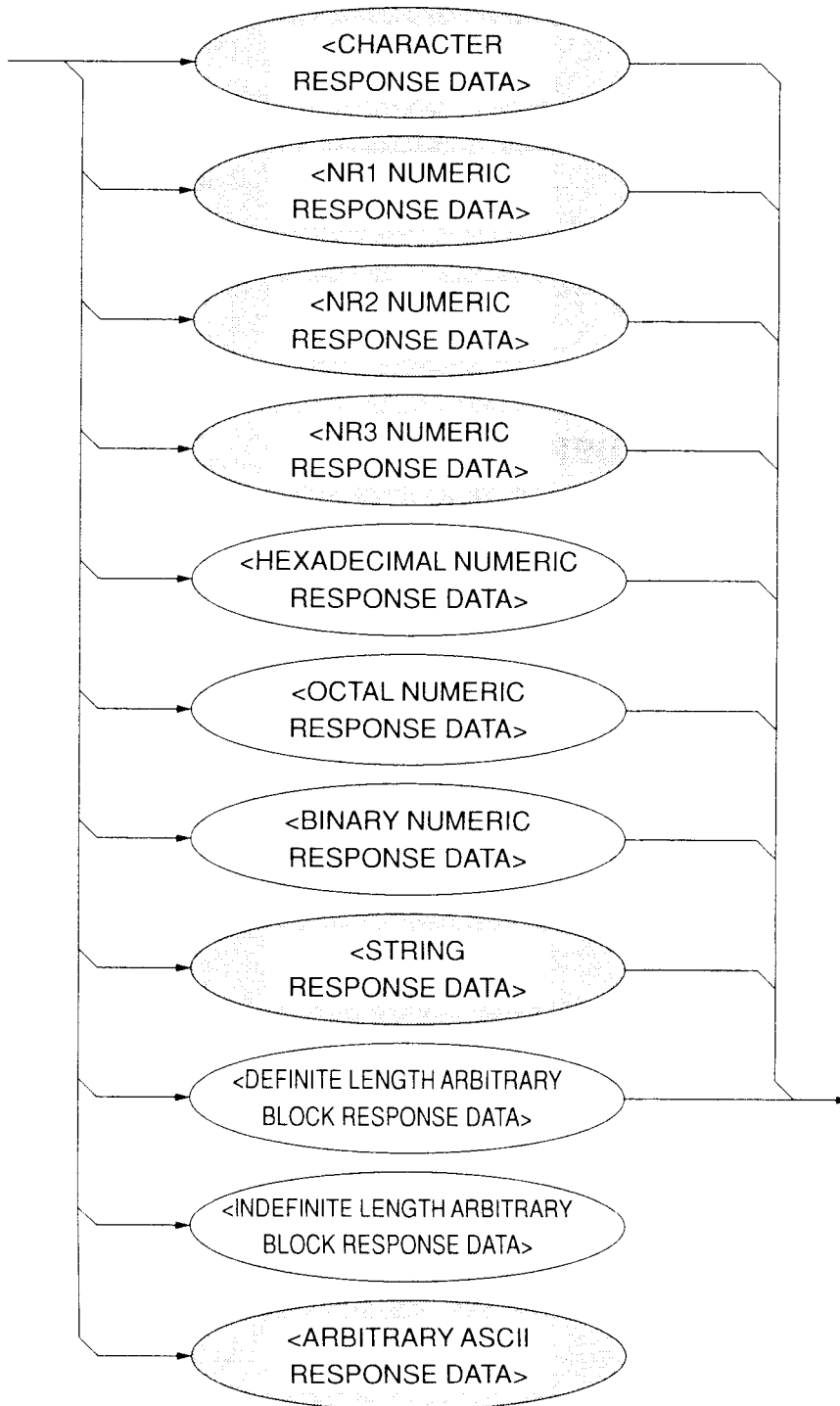

Section 5 Common IEEE488.2 Commands

This section provides descriptions of the common IEEE488.2 commands supported by this device.

The common commands can be used by the GPIB interface.

The common commands supported by this device are all sequential commands.

5.1 Common IEEE488.2	5-2
----------------------------	-----

Section 5 Common IEEE488.2 Commands

5.1 Common IEEE488.2

The table below lists common IEEE488.2 commands supported by this device.

Table 5-1 List of Common IEEE488.2 Commands

Mnemonic	Description
*IDN?	Identification Query
*OPC	Operation Complete Command
*OPC?	Operation Complete Query
*WAI	Wait Continue Command
*CLS	Clear Status Command
*ESE	Standard Event Status Enable Command
*ESE?	Standard Event Status Enable Query
*ESR?	Standard Event Status Register Query
*SRE	Service Request Enable Command
*SRE?	Service Request Enable Query
*STB?	Read Status Byte Query
*PSC	Power On Status Clear Command
*PSC?	Power On Status Clear Query
*SAV	Save Command
*RCL	Recall Command
*OPT?	Option Identification Query

*IDN?	Identification Query
Response	<ARBITRARY ASCII RESPONSE DATA> <Name of product manufacturer>, <Model name>, <Serial No.>, <Firmware Revision No.> In this device: ANRITSU, MP1777A, 0, 01
Function	Reports data including the name of product manufacturer and model name.
Example of use	> *IDN? < ANRITSU, MP1777A, 0, 01
*OPC	Operation Complete Command
Parameter	None
Function	Sets the bit 0 (bit to end operations) of the standard event status register and switches SRQ ON when the execution of the previous instruction is completed.
Example of use	> *RCL 1 : *OPC
*OPC?	Operation Complete Query
Response	<NRI NUMERIC RESPONSE DATA>
Function	Returns 1 when the execution of the previous instruction is completed.
Example of use	> *RCL 1 : *OPC? < 1
*WAI	Wait Continue Command
Parameter	None
Function	Keeps the commencement of the execution of the next instruction on hold until the execution of the previous instruction is completed. (Executes the overlap command as the sequential command.) This function is effective only for the previous instruction.
Example of use	> *WAI

Section 5 Common IEEE488.2 Commands

*CLS	Clear Status Command
Parameter	None
Function	Clears all the status composition excluding the output queue and MAV summary message. However, the enable register and Transition filter are not cleared. Clears both the output queue and MAV bit when *CLS is sent immediately after the <PROGRAM MESSAGE TERMINATOR>, and at the same time, before the <Query MESSAGE UNIT> element.
Example of use	> *CLS
*ESE	Standard Event Status Enable Command
Parameter	<DECIMAL NUMERIC PROGRAM DATA> Integer value between 0 and 255. Set as the parameter the sum total of the bits desired to be enabled among the standard event status enable register. Set 1 for enable and 0 for disable. See the Section for the "Status Byte" for the composition of the register of this device.
Function	Sets and clears the standard event status enable register.
Example of use	Sets bits 2 and 4 of the standard event status enable register. > *ESE 20
*ESR?	Standard Event Status Register Query
Response	<NR1 NUMERIC RESPONSE DATA> Integer value between 0 and 255. Set as the response the sum total of the bits of the standard event status register. See the Section for the "Status Byte" for the composition of the register of this device.
Function	Inquires about the current value of the standard event status register.
Example of use	When a command error is found. > *ESR? < 32

*SRE	Service Request Enable Command
Parameter	<p><DECIMAL NUMERIC PROGRAM DATA> Integer value between 0 and 255. Set as the parameter the sum total of the bits desired to be enabled among the service request enable register. Set 1 for enable and 0 for disable. See the Section for the "Status Byte" for the composition of the register of this device.</p>
Function	Sets and clears the service request enable register.
Example of use	<p>Sets bit 4 of the service request enable register. > *SRE 16</p>
*SRE?	Service Request Enable Query
Response	<p><NRI NUMERIC RESPONSE DATA> Integer value between 0 and 255. Set as the response the sum total of the bits of the service enable register. See the Section for the "Status Byte" for the composition of the register of this device.</p>
3 Function	Inquires about the current value of the service request enable register.
Example of use	<p>> *SRE? < 16</p>
*STB?	Read Status Byte Query
Response	<p><NRI NUMERIC RESPONSE DATA> Integer value between 0 and 255. Set as the response the sum total of the bits of the status byte register. See the Section for the "Status Byte" for the composition of the register of this device.</p>
Function	Inquires about the current value of the status byte register including the MSS (Master Summary Status) bit.
Example of use	<p>In the absence of errors or event queue > *STB? < 4</p>

Section 5 Common IEEE488.2 Commands

*PSC	Power On Status Clear Command
Parameter	<DECIMAL NUMERIC PROGRAM DATA> 0 Sets the power ON status clear flag to false. 1 Sets the power ON status clear flag to true.
Function	Determines whether or not to clear each enable register of the service request, standard event status and parallel poll of the status report module when the power is switched ON. When the mode is set to 0, the enable register will not be cleared and the device is enabled to generate SRQ after the power source is turned ON. When the mode is set to 1, the enable register will be cleared and the device is disabled to generate SRQ after the power source is turned ON.
Example of use	Generates SRQ without clearing the power ON status flag. > *PSC 0 ; *SRE 32 ; *ESE 128
*PSC?	Power On Status Clear Query
Response	<NR1 NUMERIC RESPONSE DATA> 0 Sets the power ON status clear flag to false. 1 Sets the power ON status clear flag to true.
Function	Inquires about the truth or falsity of the power ON status clear flag.
Example of use	> *PSC? < 0
*SAV	Save Command
Parameter	<DECIMAL NUMERIC PROGRAM DATA> 1 to 10 4-4
Function	Writes the current device setting into the memory of specified number. There is no limit to the state to be saved. See the Table 7-1 in the Section 7.5 "Parameter". As an SCPI command that has the same function, : SYSTem : MEMory : STORe is available.
Example of use	Writes the current setting into the memory number 1. > *SAV 1

*RCL	Recall Command
Parameter	<DECIMAL NUMERIC PROGRAM DATA> 0 to 10
Function	Calls the memory of a specified number and, by doing so, returns the device to the previous state. There is no limit to the state to be loaded. See the Table 7-1 in the Section 7.5 "Parameter". As an SCPI command which has the same function, : SYSTem : MEMory : RECall is available.
Example of use	Calls the information stored in memory number 1 and performs setting. > *RCL 1

*OPT?	Option Identification Query																
Response	<ARBITRARY ASCII RESPONSE DATA> Characters to correspond to the option or unit																
	<table border="1"> <thead> <tr> <th>Option</th> <th>Character</th> </tr> </thead> <tbody> <tr> <td>Interface (Bit Rate) selection condition option Standard • 2,488 M, 4,977 M, 9,953 M</td> <td>OPT0</td> </tr> <tr> <td>Interface (Bit Rate) selection condition option Option 01 • 2,494 M, 4,988 M, 9,977 M</td> <td>OPT1</td> </tr> <tr> <td>Interface (Bit Rate) selection condition option Option 02 • 2,666 M, 5,332 M, 10,644 M</td> <td>OPT2</td> </tr> <tr> <td>Interface (Bit Rate) selection condition option Option 04 • 3,062 M, 6,125 M, 12,249 M</td> <td>OPT4</td> </tr> <tr> <td>Interface (Bit Rate) selection condition option Option 05 • 3,069 M, 6,138 M, 12,276 M</td> <td>OPT5</td> </tr> <tr> <td>Interface (Bit Rate) selection condition option Option 06 • 2,677 M, 5,355 M, 10,709 M</td> <td>OPT6</td> </tr> <tr> <td>Interface (Bit Rate) selection condition option Option 07 • 2,578 M, 5,156 M, 10,313 M</td> <td>OPT7</td> </tr> </tbody> </table>	Option	Character	Interface (Bit Rate) selection condition option Standard • 2,488 M, 4,977 M, 9,953 M	OPT0	Interface (Bit Rate) selection condition option Option 01 • 2,494 M, 4,988 M, 9,977 M	OPT1	Interface (Bit Rate) selection condition option Option 02 • 2,666 M, 5,332 M, 10,644 M	OPT2	Interface (Bit Rate) selection condition option Option 04 • 3,062 M, 6,125 M, 12,249 M	OPT4	Interface (Bit Rate) selection condition option Option 05 • 3,069 M, 6,138 M, 12,276 M	OPT5	Interface (Bit Rate) selection condition option Option 06 • 2,677 M, 5,355 M, 10,709 M	OPT6	Interface (Bit Rate) selection condition option Option 07 • 2,578 M, 5,156 M, 10,313 M	OPT7
Option	Character																
Interface (Bit Rate) selection condition option Standard • 2,488 M, 4,977 M, 9,953 M	OPT0																
Interface (Bit Rate) selection condition option Option 01 • 2,494 M, 4,988 M, 9,977 M	OPT1																
Interface (Bit Rate) selection condition option Option 02 • 2,666 M, 5,332 M, 10,644 M	OPT2																
Interface (Bit Rate) selection condition option Option 04 • 3,062 M, 6,125 M, 12,249 M	OPT4																
Interface (Bit Rate) selection condition option Option 05 • 3,069 M, 6,138 M, 12,276 M	OPT5																
Interface (Bit Rate) selection condition option Option 06 • 2,677 M, 5,355 M, 10,709 M	OPT6																
Interface (Bit Rate) selection condition option Option 07 • 2,578 M, 5,156 M, 10,313 M	OPT7																
Function	Reports on the list of options and units mounted. Reports on options and units mounted all delimited by a comma.																
Example of use	Options 01 and 02 are mounted. > *OPT? < OPT1, OPT2																

Section 5 Common IEEE488.2 Commands

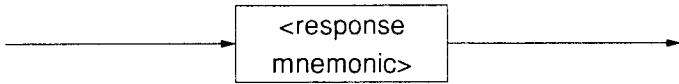
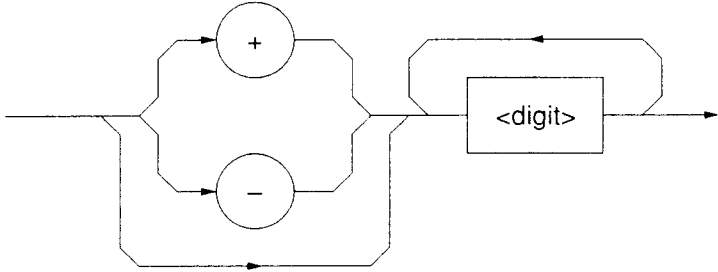
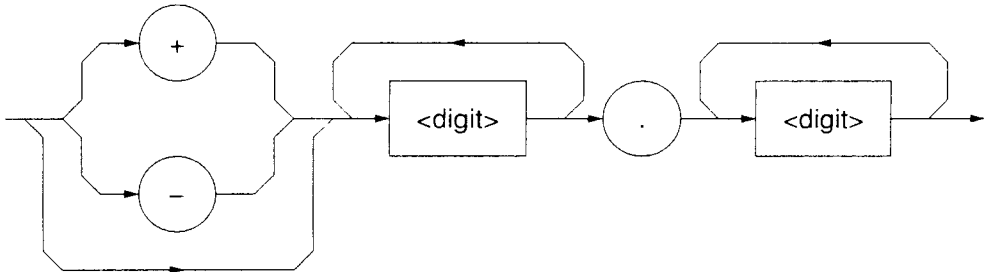
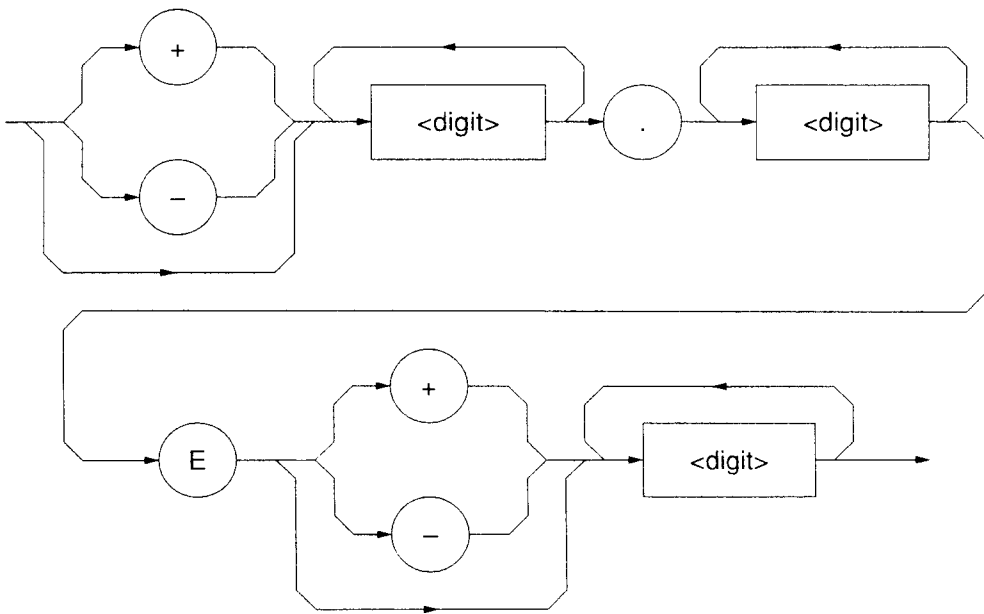
Element	Function
<p>(1) CHARACTER RESPONSE DATA</p> <p><i>Example:</i> ABC DEFG</p>	<p>Expresses short mnemonic data.</p> 
<p>(2) NR1 NUMERIC RESPONSE DATA</p> <p><i>Example:</i> 123 +123 -1234</p>	<p>Expresses integer values of decimal digits.</p> 
<p>(3) NR2 NUMERIC RESPONSE DATA</p> <p><i>Example:</i> 12.3 +12.34 -12.345</p>	<p>Expresses fixed point numerical values.</p> 
<p>(4) NR3 NUMERIC RESPONSE DATA</p> <p><i>Example:</i> 1.23E+45 -12.3E+45</p>	<p>Expresses real numbers of decimal digits with exponent.</p> 

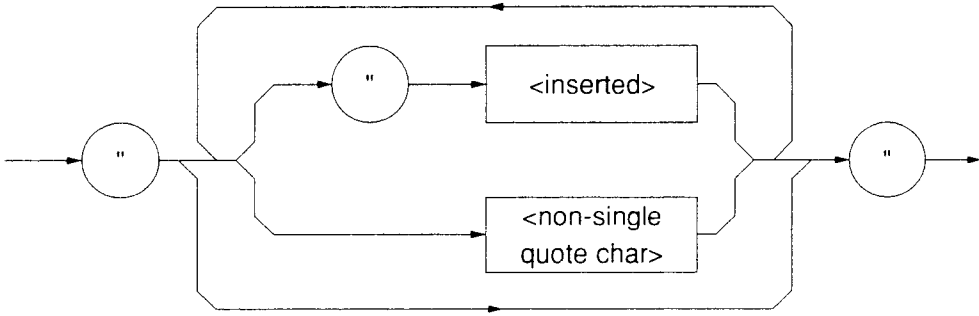
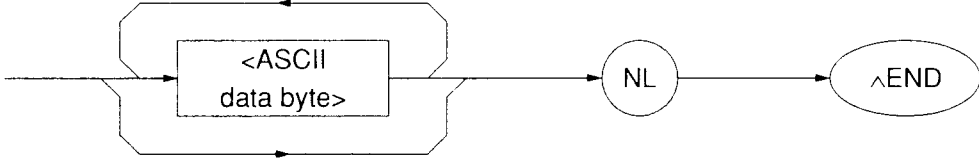
Element	Function
<p>(5) STRING RESPONSE DATA</p> <p><i>Example:</i></p> <p>"1234"</p> <p>"ABCD"</p> <p>"1234.5"</p>	<p>Expresses a character string in double quotations (").</p>  <p>The diagram shows a flow starting from an input arrow on the left into a circle containing a double quote character. From this circle, the flow splits into two paths. The upper path goes through a circle containing a double quote character, then a box labeled '<inserted>', and finally into a second circle containing a double quote character. The lower path goes through a box labeled '<non-single quote char>' and also into the second circle. Both paths then merge into a single output arrow on the right.</p>
<p>(6) ARBITRARY ASCII RESPONSE DATA</p> <p><i>Example:</i></p> <p><ASCII> <ASCII Byte> NL^END</p>	<p>Sends ASCII data bytes excluding the NL character without delimiting them. For this reason, NL^END (or NL only) is placed next to the last data, and the data is accordingly terminated without an exit point.</p> <p>An example of using the GPIB interface is shown below.</p>  <p>The diagram shows a flow starting from an input arrow on the left into a box labeled '<ASCII data byte>'. The flow then goes into a circle containing 'NL', and finally into an oval containing '^END'.</p>

Section 5 Common IEEE488.2 Commands

Section 6 Status Report

The configuration of the status registers of the MP1777A conforms to the SCPI stipulations. (SCPI: Standard Command for Programmable Instruments, see the Section 7 for more information.)

This section provides descriptions of the configuration of status registers and definition of the status register bit specific to the device.

6.1 Configuration of MP1777A Status Registers	6-2
6.2 Status Registers Specified by IEEE488.2	6-4
6.3 Status Register Specified by SCPI	6-6
6.4 Status Register Specific to MP1777A	6-7
6.5 Reading, Writing and Clearing Status Registers	6-8

6.1 Configuration of MP1777A Status Registers

SCPI stipulates that the status register configuration must conform to the configuration specified by IEEE488.2 and incorporate the SCPI OPERation status register and QUEStionable status register specific to SCPI.

The figure below shows a simple block diagram of status registers mounted on this device. (Explanations of the bit position and width to be provided later)

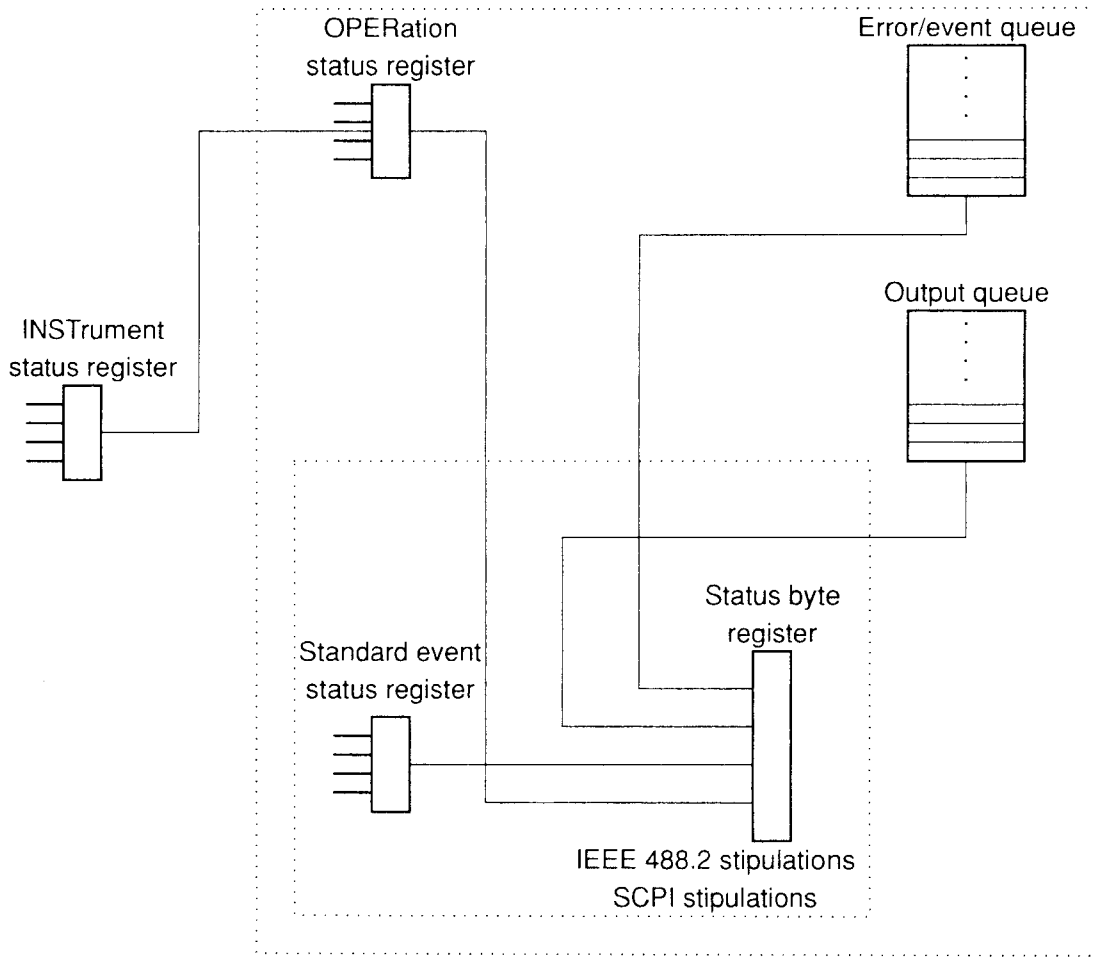

Fig. 6-1 Block Diagram of Status Registers

Registers specified by IEEE488.2 are event register and status byte register.

Register specified by SCPI is OPERation status register.

Device-specific register is INSTRument status register.

6.1 Configuration of MP1777A Status Registers

Status registers excluding the registers specified by IEEE488.2 are configured as follows.

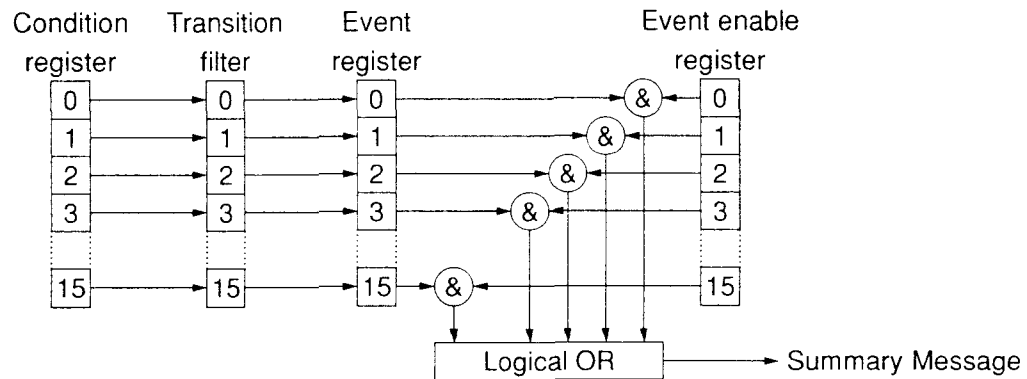

Fig. 6-2 Block Diagram of each Status Register

Table 6-1 Definitions of Register and Filter

Register and Filter	Definition
Condition register	Monitors the device status and performs real-time change in accordance with the device status. For this reason, this register does not store the status.
Transition filter	Sets the condition register details to the event register. The transition filter comes in three modes, depending on the changes of the condition register to be evaluated. Positive direction change: The event becomes true only when the corresponding condition changes from false to true. Negative direction change: The event becomes true only when the corresponding condition changes from true to false. Both direction change: The event becomes true when a change into the positive or negative direction takes place.
Event register	Stores the output of the transition filter.
Event enable register	Selects the bit of corresponding Event Register to trigger a shift of summary message to true.

6.2 Status Registers Specified by IEEE488.2

IEEE488.2 specifies the two status registers shown below.

Table 6-2 Definitions of Status Registers Specified by IEEE488.2

Status Register	Definition
Status byte register	A register to set RQS and seven summary message bits. Being used in combination with the service request enable register, this register sets SQR ON when the logical OR of the two is not zero. RQS is system reserved in bit 6 and this bit reports to the external controller the presence of service request.
Standard event status register	Sets eight types of events the device will encounter as standard events. The logical OR output bit is summarized and displayed in bit 5 of the status byte register as the ESB (Event Status Bit) summary message.

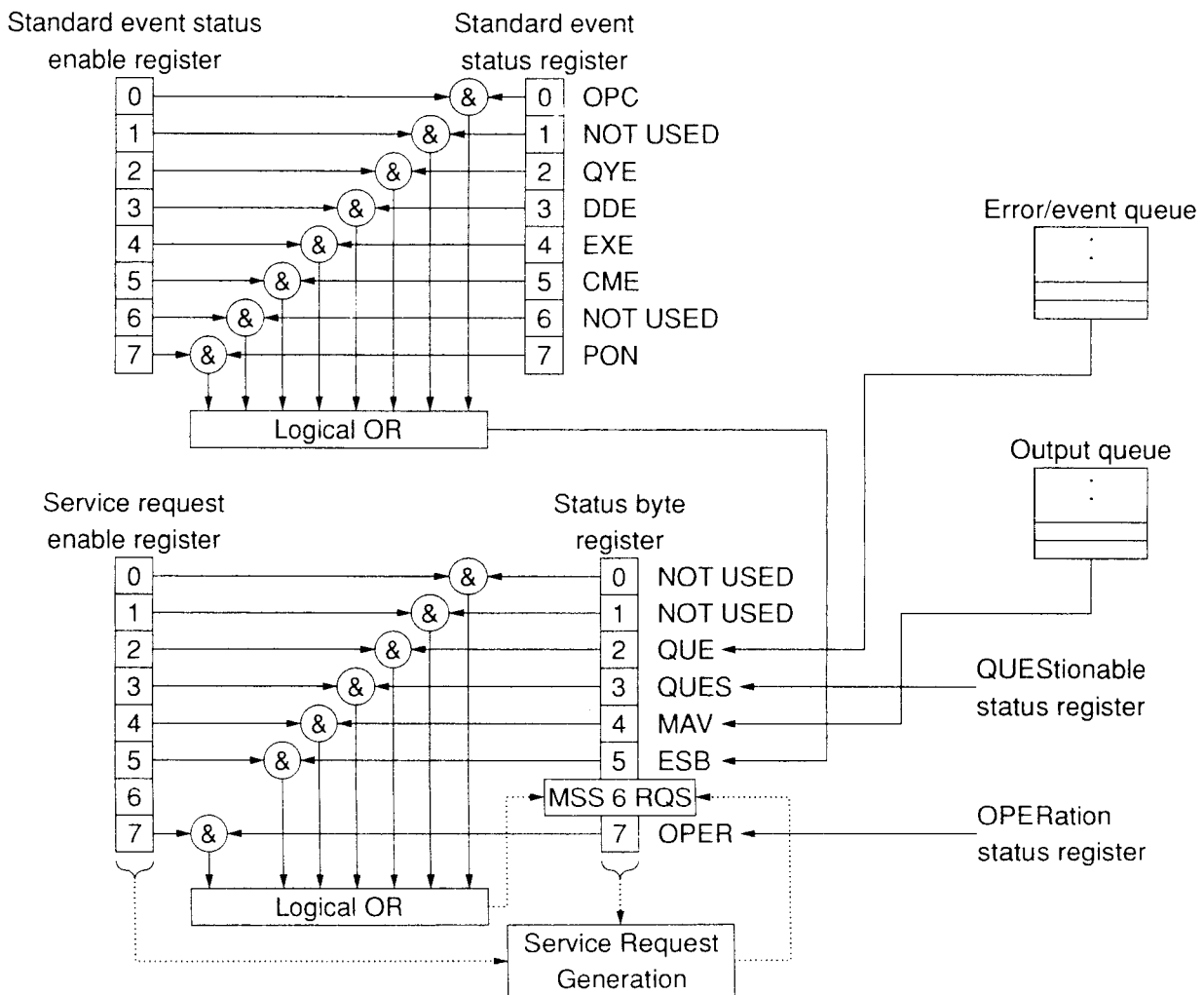

6.2 Status Registers Specified by IEEE488.2

The tables below show the definition of register bit specified by IEEE488.2.

Table 6-3 Definition of Status Byte Register Bit

Bit	Status Byte Register		Definition
DB2	QUE	(Error/Event QUEue)	Indicates that the error and event queues are not empty.
DB4	MAV	(Massege AVailable)	Indicates that the output queue is not empty.
DB5	ESB	(Event Summary Bit)	Standard event status register summary
DB6	RQS	(Request Service)	RQS message
	MSS	(Master Summary Status)	Indicates that the device has a cause to request at least one service.
DB7	OPER	(OPERation status register summary)	OPERation status register summary

Table 6-4 Definition of Standard Event Status Register Bit

Bit	Standard Event Status Register		Definition
DB0	OPC	(Operation Complete)	Indicates that all the specified operations are completed.
DB2	QYE	(Query Error)	Indicates that a query error has taken place.
DB3	DDE	(Device-dependent Error)	Indicates that an error other than a command, query or run time error has taken place.
DB4	EXE	(Execution Error)	Indicates that a run time error has taken place.
DB5	CME	(Command Error)	Indicates that a command error has taken place.
DB6	URQ	(User Request)	Indicates that a local control error has taken place.
DB7	PON	(Power on)	Indicates that the power source has switched from OFF to ON.

6.3 Status Register Specified by SCPI

The following section shows the definition of the register bit specified by SCPI.

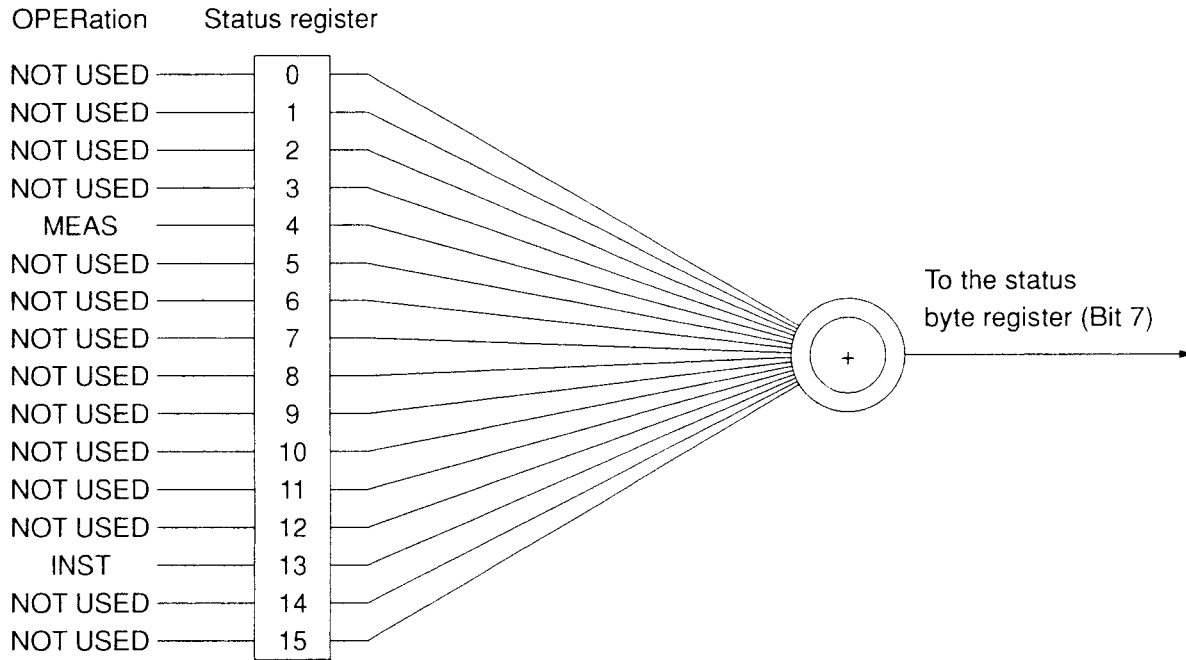

Fig. 6-3 Definition of Register Bit Specified by SCPI

Table 6-5 Definition of OPERation Status Register Bit

Bit	OPERation Status Register	Definition
DB4	MEAS (MEASuring)	Indicates that the measurement is being performed.
DB13	INST (INSTrument status register summary)	INSTrument status register summary

6.4 Status Register Specific to MP1777A

The following section shows the definition of the device-specific register bit.

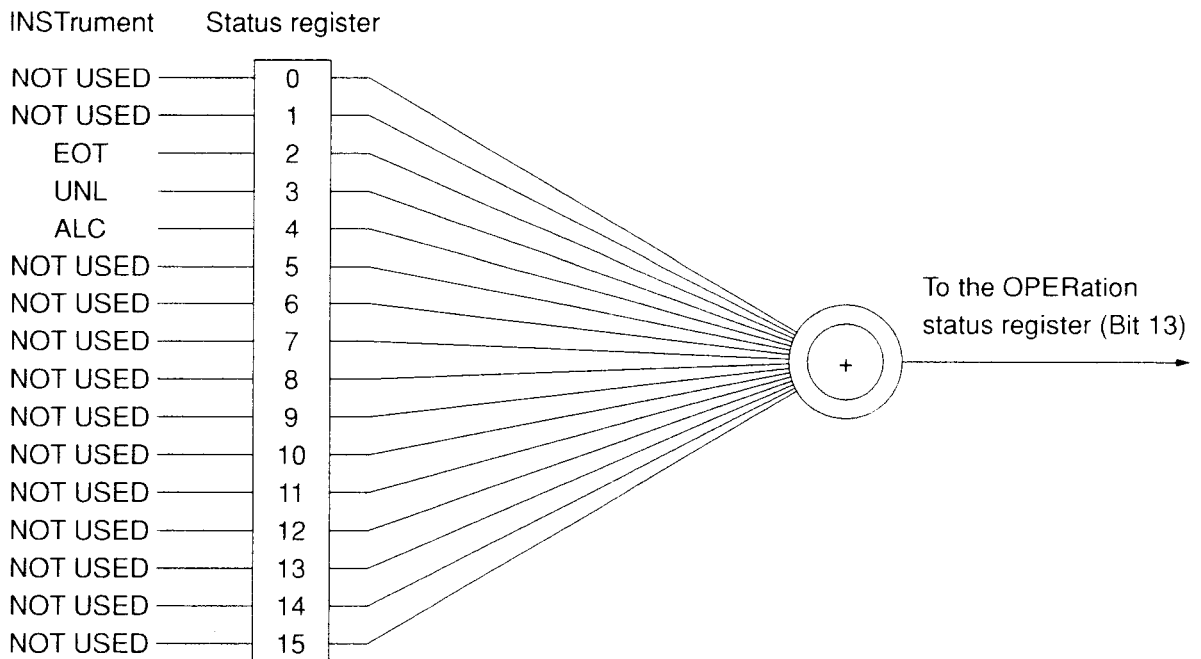

Fig. 6-4 Definition of INSTRUMENT Register Bit

Table 6-6 Definition of INSTRUMENT Status Register Bit

Bit	INSTRUMENT Status Register		Definition
DB2	EOT	(End Of Test period)	Indicates that the test (measurement) has finished.
DB3	UNL	(UNLock)	Indicates that Unlock has taken place.
DB4	ALC	(Alarm Change)	Indicates that the alarm has changed.

6.5 Reading, Writing and Clearing Status Registers

(1) Reading and writing methods

The table below shows the methods of reading and writing the details of status registers.

Table 6-7 Reading and Writing Methods of Status Registers

Register	Reading Methods	Writing Methods
Status byte register	Serial poll Seven-bit status byte and RQS message bit are returned. In this case, the status byte value does not change. Common *STB? query The details of the status byte register and one numerical value from MSS (Master Summary Status) are returned.	Disabled
Service request enable register	Common *SRE? query	Common *SRE? command
Standard event status register	Common *ESR? query In this case, the details of the register is cleared after it is read.	Disabled
Standard event status enable register	Common *ESE? query In this case, the detail of the register will not change.	Common *ESE? command
SCPI event register	SCPI command (STATUS subsystem) : STATUS : ... : EVENT? In this case, the details of the register will be cleared.	Disabled
SCPI enable register	SCPI command (STATUS subsystem) : STATUS : ... : ENABLE In this case, the details of the register will not change.	SCPI command (STATUS subsystem) : STATUS : ... : ENABLE?
SCPI Transition filter	SCPI command (STATUS subsystem) : STATUS : ... : PTRansition? : STATUS : ... : NTRansition? In this case, the details of the register will not change.	SCPI command (STATUS subsystem) : STATUS : ... : PTRansition : STATUS : ... : NTRansition
Error/Event Queues	SCPI command : SYSTem : ERRor?	Disabled

NOTES :

1. The SCPI event register, SCPI enable register and SCPI Transition filter correspond to the event register, enable register and Transition filter in the status registers specified by SCPI and the device-specific status registers.
2. See the Section 5 "Common IEEE488.2 Commands" for more information on the common commands and queries and the Section 8 "Device Message Details" for more information on the SCPI commands.

(2) Clearing and resetting methods

The table below shows clearing and resetting methods of status registers and the range of their effects.

Table 6-8 Clearing and Resetting Methods of Status Registers

Register	*RST	*CLS	Power Source ON #	STATUS:PRESet	Other Clearing Methods
Status byte register	No change	Clear	Clear	No change	
Service request	No change	No change	Clear	No change	Execution of *SRE 0
Standard event status register	No change	Clear	Clear	No change	Reading of events by *ESR? to clear the status register
Standard event status enable register	No change	No change	Clear	No change	Execution of *ESE 0
SCPI event register	No change	Clear	Clear	No change	Reading of events by : STATUS : ... : EVENT? to clear the status register
SCPI enable register	No change	No change	Reset	Reset	Execution of : STATUS : ... : ENABLE 0
Execution of the SCPI Transition filter	No change	No change	Reset	Reset	: STATUS : ... : PTRansition 0 : STATUS : ... : NTRansition 0
Error/event queue	No change	Clear	Clear	No change	Reading of all the events by : SYSTem : ERRor?

NOTES :

1. The SCPI event register, SCPI enable register and SCPI transition filter correspond to the event register, enable register and transition filter in the status registers specified by SCPI and device-specific status registers.
2. Cleared (or reset) when the power source is switched ON with the *PSC (Power-ON Status Clear) flag set as true by the common PSC command.

The table below shows the reset values of registers influenced by the : STATUS : PRESet command.

Register 0	Enable/Filter	Reset Value
OPERational status register QUESTionable status register	Enable register	ALL 0
	PTRansition filter	ALL 1
	NTRansition filter	ALL 0
INSTrument status register	Enable register	ALL 1
	PTRansition filter	ALL 1
	NTRansition filter	ALL 0
Other status registers	Enable register	ALL 1
	PTRansition filter	ALL 1
	NTRansition filter	ALL 1

Section 6 Status Report

Section 7 SCPI Outline

The MP1777A adopts SCPI (Standard Commands for Programmable Instruments) as commands to perform remote control.

This section provides the outline of SCPI and explanations of the command system.

This section and subsequent Sections describe the examples of command use and response as follows.

- > Program message (program command, query command)
- < Response

7.1 Outline	7-2
7.2 Command Structure	7-3
7.3 Command Description Method	7-4
7.4 Compounding Commands	7-5
7.5 Parameter.....	7-6

Section 7 SCPI Outline

7.1 Outline

SCPI is a device command language defined by the SCPI consortium and is independent from the hardware.

SCPI is designed to shorten the period for development of automatic measuring instrument (ATE). For this reason, the programming environments such as the device control and data handling are made consistent.

Moreover, it is characterized by its ability to perform totally even control of devices of the same model as well as devices of different models compatible with each other that are equipped with the same functions.

7.2 Command Structure

The SCPI command form a hierarchical structure. Commands are divided into groups, each of which consists of commands of similar functions, and each group forms a hierarchical structure called the subsystem.

This specification expresses these subsystems by the command tree as shown below.

SCPI allows the same headers to be present in a tree and the difference in the location of the header corresponds to the difference in the function. Therefore, a command must be described in a full path up to the header to be used.

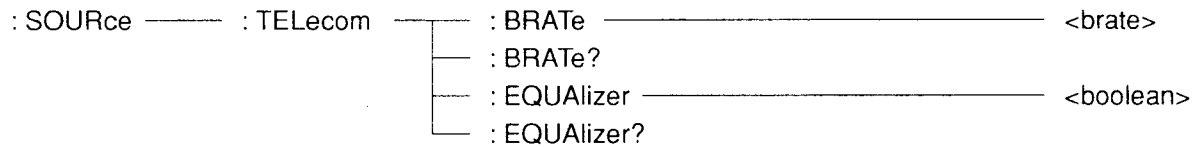

Fig. 7-1 Example of SCPI Command Tree

7.3 Command Description Method

```
: SOURce : TELecom : BRATe <brate>  
: SOURce : TELecom : BRATe?  
: SOURce : TELecom : EQUAlizer <boolean>  
: SOURce : TELecom : EQUAlizer?
```

Fig. 7-2 Example of SCPI Commands

The command tree shown in the previous section consists of the commands shown above. The section below provides explanations of the stipulations concerning descriptions of commands.

<Command format>

A command begins with a colon (:).
Or, a command is structured by concatenating headers with a colon (:).

<Form of header abbreviation>

Headers come in short and long forms.
The short form signifies an abbreviated form of the long form.
A command is interpreted as the same command whether it is expressed in the short or long form.
(The short and long form can be mixed.)
This specification uses the uppercase and lowercase characters to distinguish the short and long forms. (The section expressed in uppercase characters refers to the short form.) However, the uppercase and lowercase characters are not distinguished when they are actually used.

Example:

Long form	> : SOURce : TELecom : BRATe M9953
Short form	> sour : TEL : BRAT M9953
Long+short form	> Sour : TELecom : BRAT M9953

<Option node>

The section in the brackets ([and]) expresses the option node. The header enclosed by the brackets ([and]) can be abbreviated, and the abbreviated and non-abbreviated forms of a header are interpreted as the same command.

Example:

When a header is not abbreviated	> : DISPlay : DSElect : NAME "SETup"
When a header is abbreviated	> : DISPlay : DSElect : "SETup"

<Header separator>

At least one space character is always inserted between a command and a parameter. Two or more parameters are separated by a comma (,).

7.4 Compounding Commands

Commands can be compounded by using semi-colon (;) as shown by the example below.

The second command is also referenced as the command located at the same level as the lowest hierarchical level of the first command.

For this reason, the second command can be described in a full path as shown by Example 1. However, as Example 2 shows, headers located in the layer above Type can also be abbreviated.

Example 1:

```
> : SENSE : TELEcom : PATTeM : TYPE UWORd16 ; : SENS : TELEcom : PATTeM : UWORd "1100110011001100"
```

Example 2:

```
> : SENSE : TELEcom : PATTeM : TYPE UWORd16 ; UWORd "1100110011001100"
```

7.5 Parameter

The table below shows types of parameters used by this measuring instrument

This operation manual expresses parameter types in lowercase characters enclosed by angled brackets (< and >) in the table below.

Moreover, the <PROGRAM DATA> type corresponding to the parameter type, specified by IEEE488.2 (or SCPI), is expressed in uppercase characters.

The correspondence between each parameter type and <PROGRAM DATA> specified by IEEE488.2 (or SCPI) is described for each command.

Table 7-1 Details of Parameter Type

Parameter Type	Explanations
<numeric> <DECIMAL NUMERIC PROGRAM DATA>	Expresses a decimal digit. <CHARACTER PROGRAM DATA> such as MINimum and MAXimum are included as special numerical value type data. The numerical values used by this device are mainly integer type. Therefore, the fractional part is rounded.
<boolean> <BOOLEAN PROGRAM DATA> (Defined by SCPI)	Expresses a theoretical value. OFF or 0 corresponds to false and ON or 1 corresponds to true. The setting can be done by 0 and 1, or OFF and ON. However, the setting for the response to a query must be done by 0 or 1.
<string> <STRING PROGRAM DATA>	Expresses a character string, made of ASCII characters enclosed by single quotation marks (') or double quotation marks (") . Either long or short form can be used. <i>Example:</i> 'LOF : M139' or "LOF : M139"
<brate>, <type>..etc <CHARACTER PROGRAM DATA>	Expresses a character data. Expressed in a short character string that corresponds to the setting details Either the long or short form can be used.

Section 8 Device Message Details

This section provides detailed explanations of the device messages supported by the MP1777A.

Examples of command use and responses are described as follows in this Section.

- > Program message (program command and query command)
- < Response

8.1	Response Format	8-2
8.2	Buffer Size Stipulations	8-4
8.3	Device-Specific Commands	8-5
8.3.1	INSTRument Subsystem	8-7
8.3.2	SOURce Subsystem	8-8
8.3.3	SENSe Subsystem	8-14
8.3.4	DISPlay Subsystem	8-21
8.3.5	CALCulate Subsystem	8-24
8.3.6	SYSTem Subsystem	8-25
8.3.7	STATus Subsystem	8-29

Section 8 Device Message Details

8.1 Response Format

This section explains the format of the response to the query command
The format is shown in the table below.

Table 8-1 Response Format (By Response Type)

Response Type	Format
<numeric>, <year> <NR1 NUMERIC RESPONSE DATA>	Makes the number of digits of the response variable and sets the maximum number of digits within the range of numerical values as the maximum number of digits. No space is inserted between the sign and numerical value. > : SYSTem : DATE? < 1993, 7, 14
<brate>, <type>...etc <CHARACTER RESPONSE DATA>	A short form of a character is returned. > : INSTrument : COUPle? < ALL
<string>, <display>...etc <STRING RESPONSE DATA>	A string enclosed by the quotation marks (") is returned. When short and long forms are both found in the string of the corresponding command, the short form is returned. > : DISPlay : DSElect : NAME? < "SET" (short form of "SETup") See Table 8-2 for the response format, Form 6.

Table 8-2 Details of Response Format

Type	Format	Explanation	
Form 6 UI type	Tx	"XXXX"	When $0.000 \leq \text{Value} \leq 3,232$ in the 3,200 UI Range UI _{PP}
		"XXXX"	When $0.000 \leq \text{Value} \leq 1,616$ in the 1,600 UI Range UI _{PP}
		"XXX.X"	When $0.000 \leq \text{Value} \leq 808.0$ in the 800 UI Range UI _{PP}
		"XX.XX"	When $0.000 \leq \text{Value} \leq 80.80$ in the 80 UI Range UI _{PP}
		"XX.XX"	When $0.000 \leq \text{Value} \leq 40.40$ in the 40 UI Range UI _{PP}
		"XX.XX"	When $0.000 \leq \text{Value} \leq 20.20$ in the 20 UI Range UI _{PP}
		"X.XXX"	When $0.000 \leq \text{Value} \leq 0.505$ in the 0.5 UI Range UI _{PP}
			Five characters aligned to the right among six characters > : SOURce : JITTer : AMPLitude? < "2000"
		"> 3232"	When Value > 3,232 (1 UI Range, UI _{PP})
		"> 1616"	When Value > 1,616 (1 UI Range, UI _{PP})
		"> 808.0"	When Value > 808.0 (1 UI Range, UI _{PP})
		"> 80.80"	When Value > 80.80 (1 UI Range, UI _{PP})
		"> 40.40"	When Value > 40.40 (1 UI Range, UI _{PP})
		"> 20.20"	When Value > 20.20 (1 UI Range, UI _{PP})
	"> 0.505"	When Value > 0.505 (1 UI Range, UI _{PP})	
Rx	"X.XXX"	When $0.000 \leq \text{Value} \leq 1.010$ in the 1 UI Range UI _{PP} When $0.000 \leq \text{Value} \leq 0.505$ in the 1 UI Range UI _{+P} , UI _{-P} When $0.000 \leq \text{Value} \leq 0.375$ in the 1 UI Range UI _{rms} Five characters aligned to the right among six characters > : CALCulate : DATA? "JAMPLitude : PTPeak" < "1.234"	
	"X.XX"	When $0.00 \leq \text{Value} \leq 4.04$ in the 4 UI Range UI _{PP} When $0.00 \leq \text{Value} \leq 2.02$ in the 4 UI Range UI _{+P} , UI _{-P} When $0.00 \leq \text{Value} \leq 1.43$ in the 4 UI Range UI _{rms} Four characters aligned to the right among six characters > : CALCulate : DATA? "JAMPLitude : RMS" < "7.00"	
	">1.010"	When Value > 1.010 (1 UI Range, UI _{PP})	
	">4.04"	When Value > 4.04 (4 UI Range, UI _{PP})	
	">0.505"	When Value > 0.505 (1 UI Range, UI _{-P} /UI _{-P})	
	">2.02"	When Value > 2.02 (4 UI Range, UI _{-P} /UI _{-P})	
	">0.357"	When Value > 0.357 (1 UI Range, UI _{rms})	
">1.43"	When Value > 1.43 (4 UI Range, UI _{rms})		
"-----"	In the absence of data to correspond to the query		

Section 8 Device Message Details

8.2 Buffer Size Stipulations

A response in the format explained earlier is sent from the device to the controller. Therefore, the controller must have a buffer of a size enough to accept the response.

When the commands of this device are used, a maximum of 255 bytes of buffer space will suffice.

8.3 Device-Specific Commands

The following section provides details of the device-specific commands.

As the command descriptions are classified by the subsystem, see the Appendix D correspondence between commands and screens for more information on the correspondence with screens.

Incidentally, the device-specific commands supported by this device are sequential commands with some exceptions. An explanation is given for commands other than sequential commands every time they come up.

When a set value by a program command causes set values for other items to become unacceptable, they will be changed to allowed values.

Moreover, the measurement starts again when settings are modified during measurement.

See the details of the operation method in this operation manual for conditions to change set values for other items and to execute restart.

The following section shows examples of descriptions of commands.

<Program command>

When a restriction on command use exists, an item called the restriction is added to the example below.

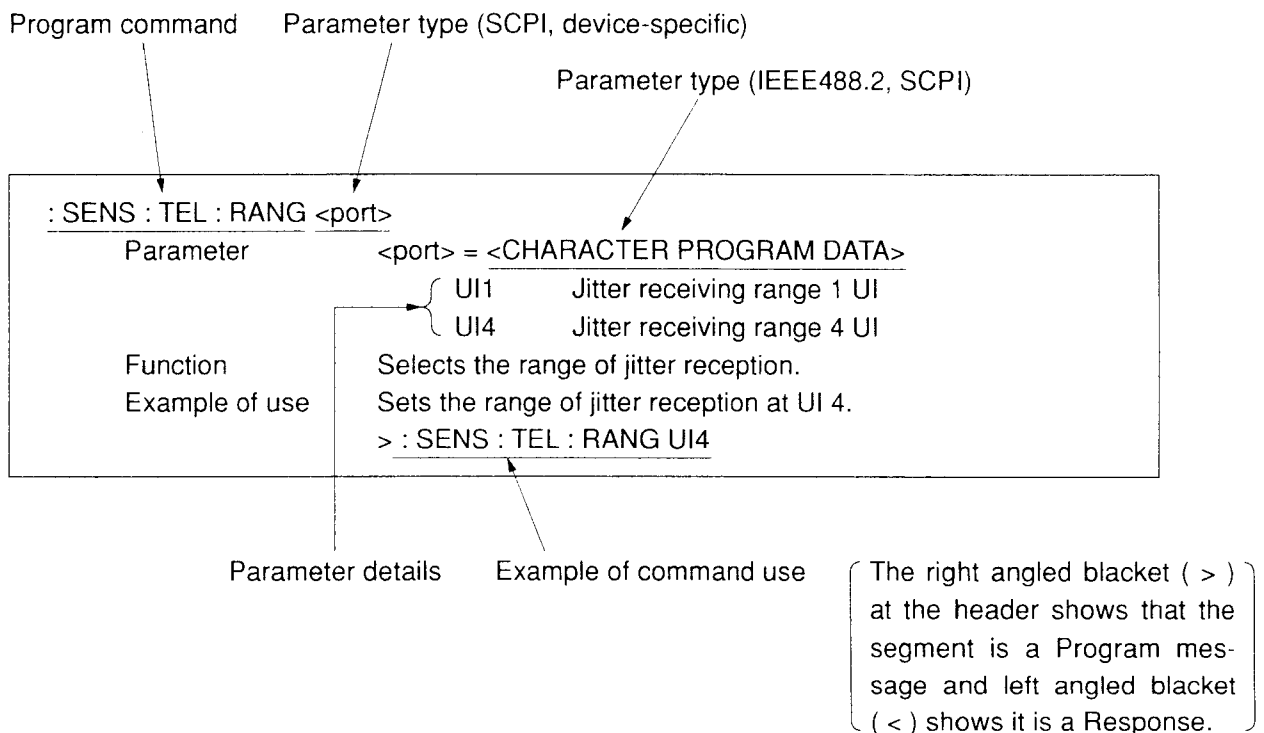

Section 8 Device Message Details

<Program Query Command>

The details of a response are omitted when a program command to correspond to the query exists. (The same as the details of the parameter of the program command)

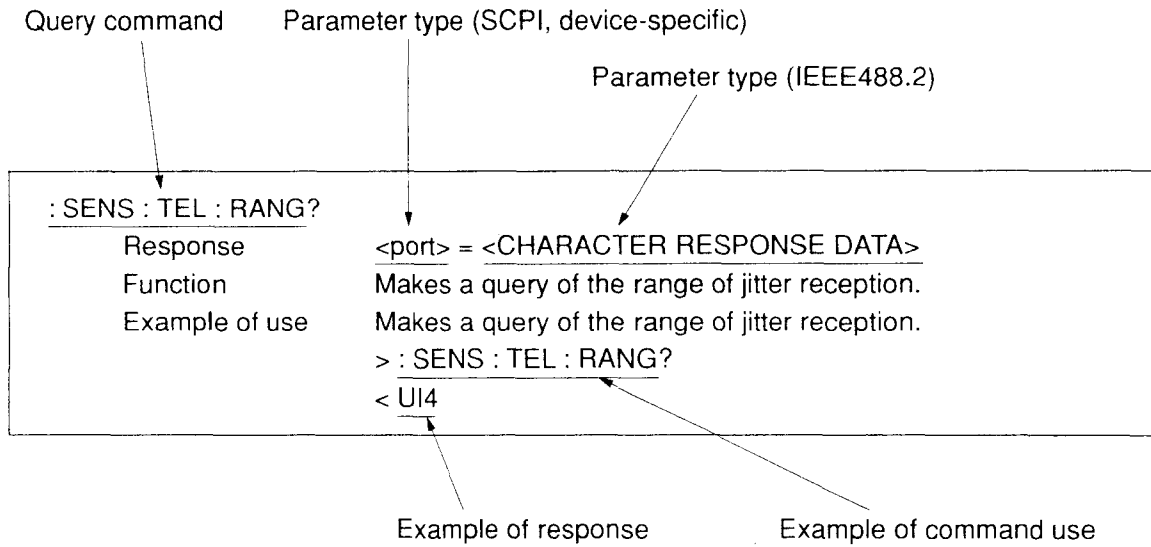

8.3.1 INSTRUMENT Subsystem

The INSTRUMENT subsystem is used to specify the same setting for the transmission and reception or independent setting for each.

```
: INSTRUMENT ———— : COUPLE ———— <mode>
                  |
                  |
                  : COUPLE?
```

: INSTRUMENT : COUPLE <mode>

Command type	Sequential command
Parameter	<mode> = <CHARACTER PROGRAM DATA> ALL Tx&Rx (Same) NONE Tx/Rx (Independent)
Function	Specifies the selection of whether to establish the same setting for the transmission and reception modules or independent setting for each.
Restriction	When the mode is switched from Tx/Rx to Tx&Rx, the set value for Rx is set for the Bit Rate.
Example of use	Sets the same setting for the transmission and reception. > : INSTRUMENT : COUPLE ALL

: INSTRUMENT : COUPLE?

Command type	Sequential command
Response	<mode> = <CHARACTER RESPONSE DATA> Same as : INSTRUMENT : COUPLE
Function	Makes a query of whether the setting is the same for the transmission and reception.
Example of use	> : INSTRUMENT : COUPLE? < ALL

Section 8 Device Message Details

8.3.2 SOURCE Subsystem

The SOURCE subsystem controls (setting and display) the transmission side.

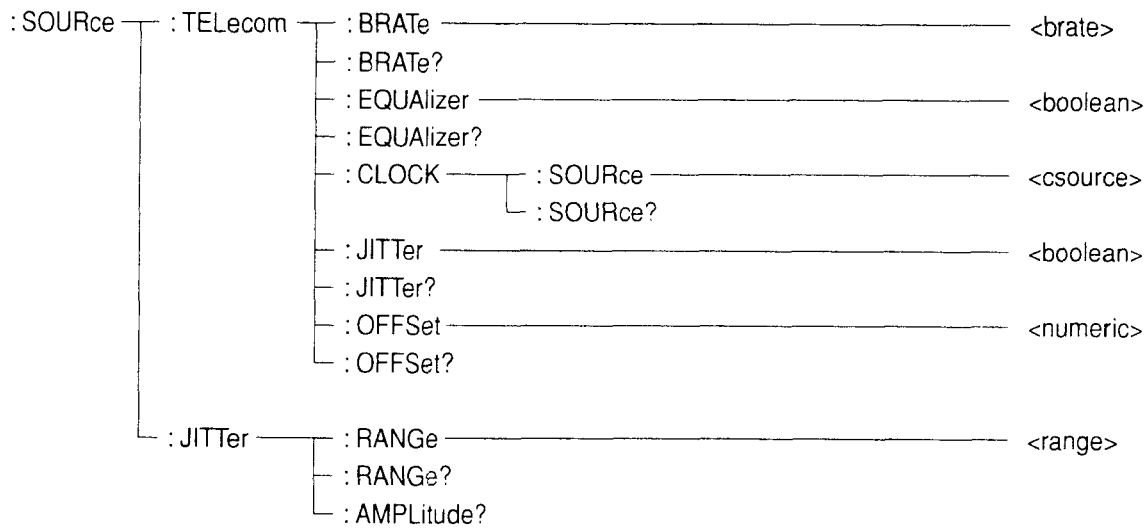

: SOURce : TELecom : BRATe <brate>

Command type	Sequential command																																
Parameter	<brate> = <CHARACTER PROGRAM DATA>																																
	<table> <tr> <td>(Standard)</td> <td>(Option 05)</td> </tr> <tr> <td>M2,488 2,488 Mbit/s</td> <td>M3069 3,069 Mbit/s</td> </tr> <tr> <td>M4,977 4,977 Mbit/s</td> <td>M6138 6,138 Mbit/s</td> </tr> <tr> <td>M9,953 9, 953 Mbit/s</td> <td>M12276 12,276 Mbit/s</td> </tr> <tr> <td>(Option 01)</td> <td>(Option 06)</td> </tr> <tr> <td>M2494 2,494 Mbit/s</td> <td>M2677 2,677 Mbit/s</td> </tr> <tr> <td>M4988 4,988 Mbit/s</td> <td>M5355 5,355 Mbit/s</td> </tr> <tr> <td>M9977 9,977 Mbit/s</td> <td>M10709 10,709 Mbit/s</td> </tr> <tr> <td>(Option 02)</td> <td>(Option 07)</td> </tr> <tr> <td>M2666 2,666 Mbit/s</td> <td>M2578 2,578 Mbit/s</td> </tr> <tr> <td>M5332 5,332 Mbit/s</td> <td>M5156 5,156 Mbit/s</td> </tr> <tr> <td>M10664 10,664 Mbit/s</td> <td>M10313 10,313 Mbit/s</td> </tr> <tr> <td>(Option 04)</td> <td></td> </tr> <tr> <td>M3062 3,062 Mbit/s</td> <td></td> </tr> <tr> <td>M6125 6,125 Mbit/s</td> <td></td> </tr> <tr> <td>M12249 12,249 Mbit/s</td> <td></td> </tr> </table>	(Standard)	(Option 05)	M2,488 2,488 Mbit/s	M3069 3,069 Mbit/s	M4,977 4,977 Mbit/s	M6138 6,138 Mbit/s	M9,953 9, 953 Mbit/s	M12276 12,276 Mbit/s	(Option 01)	(Option 06)	M2494 2,494 Mbit/s	M2677 2,677 Mbit/s	M4988 4,988 Mbit/s	M5355 5,355 Mbit/s	M9977 9,977 Mbit/s	M10709 10,709 Mbit/s	(Option 02)	(Option 07)	M2666 2,666 Mbit/s	M2578 2,578 Mbit/s	M5332 5,332 Mbit/s	M5156 5,156 Mbit/s	M10664 10,664 Mbit/s	M10313 10,313 Mbit/s	(Option 04)		M3062 3,062 Mbit/s		M6125 6,125 Mbit/s		M12249 12,249 Mbit/s	
(Standard)	(Option 05)																																
M2,488 2,488 Mbit/s	M3069 3,069 Mbit/s																																
M4,977 4,977 Mbit/s	M6138 6,138 Mbit/s																																
M9,953 9, 953 Mbit/s	M12276 12,276 Mbit/s																																
(Option 01)	(Option 06)																																
M2494 2,494 Mbit/s	M2677 2,677 Mbit/s																																
M4988 4,988 Mbit/s	M5355 5,355 Mbit/s																																
M9977 9,977 Mbit/s	M10709 10,709 Mbit/s																																
(Option 02)	(Option 07)																																
M2666 2,666 Mbit/s	M2578 2,578 Mbit/s																																
M5332 5,332 Mbit/s	M5156 5,156 Mbit/s																																
M10664 10,664 Mbit/s	M10313 10,313 Mbit/s																																
(Option 04)																																	
M3062 3,062 Mbit/s																																	
M6125 6,125 Mbit/s																																	
M12249 12,249 Mbit/s																																	
Function	Sets the sign speed of transmission signal.																																
Restriction	Sending the command while the option above is not set results in a run time error. When the same setting is established for the transmission and reception modules (Tx&Rx), the reception Bit Rate will be set.																																
Example of use	Sets the sign speed of the transmission signal to 9,953 Mbit/s. > : SOURce : TELecom : BRATe M9953																																

: SOURce : TELecom : BRATe?

Command type	Sequential command
Response	<brate> = <CHARACTER RESPONSE DATA>
Function	Makes a query of the sign speed of the transmission signal.
Example of use	> : SOURce : TELecom : BRATe? < M9953

Section 8 Device Message Details

: SOURce : TELecom : EQUALizer <boolean>

Command type	Sequential command
Parameter	<boolean> = <BOOLEAN PROGRAM DATA> OFF or 0 Equalizer OFF ON or 1 Equalizer ON
Function	Sets ON/OFF of the Jitter Setting Equalizer.
Example of use	Sets the Jitter Setting Equalizer ON. > : SOURce : TELecom : EQUALizer ON

: SOURce : TELecom : EQUALizer?

Command type	Sequential command
Response	<NRI NUMERIC RESPONSE DATA> 0 Equalizer OFF 1 Equalizer ON
Function	Makes a query of the setting status of the Jitter Setting Equalizer.
Restriction	None
Example of use	> : SOURce : TELecom : EQUALizer? < 1

: SOURce : TELecom : CLOCK : SOURce <csource>

Command type	Sequential command
Parameter	<csource> = <CHARACTER PROGRAM DATA> INTernal Internal LOCK_2MHB 2 MHz (Balanced) LOCK_2MHU 2 MHz (Unbalanced) LOCK_2MBB 2 Mbit/s (Balanced) LOCK_2MBU 2 Mbit/s (Unbalanced) LOCK_15MH 1.5 MHz (Unbalanced) LOCK_15MB 1.5 Mbit/s (Balanced) EXTernal External LOCK_10M Lock 10M (Balanced)
Function	Sets the clock source of the transmission signal.
Example of use	Sets the clock source of the transmission signal to internal. > : SOURce : TELecom : CLOCK : SOURce INTernal

: SOURce : TELeom : CLOCk : SOURce?

Command type	Sequential command
Response	<source> = <CHARACTER RESPONSE DATA> INT Internal EXT External LOCK Lock REC Receive
Function	Makes a query of the clock source of the transmission signal.
Example of use	> : SOURce : TELeom : CLOCk : SOURce? < INT

: SOURce : TELeom : JITTer <boolean>

Command type	Sequential command
Parameter	<boolean> = <BOOLEAN PROGRAM DATA> OFF or 0 No jitter to be generated ON or 1 Jitter to be generated
Function	Establishes setting of whether or not to generate jitter.
Restriction	When no jitter generation is set, attempting to set the frequency offset and jitter generation range results in an error, disabling the setting.
Example of use	Sets the jitter generation ON. > : SOURce : TELeom : JITTer ON

: SOURce : TELeom : JITTer?

Command type	Sequential command
Response	<NR1 NUMERIC RESPONSE DATA> 0 No jitter to be generated 1 Jitter to be generated
Function	Makes a query of whether or not jitter will be generated.
Example of use	> : SOURce : TELeom : JITTer? < 1

Section 8 Device Message Details

: SOURce : TELecom : OFFSet <numeric>

Command type	Sequential command
Parameter	<numeric> = <DECIMAL NUMERIC PROGRAM DATA> -50 to +50 ... step 0.1
Function	Performs the frequency offset setting.
Example of use	Sets the value of frequency offset at +25. > : SOURce : TELecom : OFFSet 25

: SOURce : TELecom : OFFSet?

Command type	Sequential command
Response	<NR1 NUMERIC RESPONSE DATA> -50 to +50 ... step 0.1
Function	Makes a query of the value of frequency offset.
Example of use	> : SOURce : TELecom : OFFSet? < -25

: SOURce : JITTer : RANGe <range>

Command type	Sequential command
Parameter	<range> = <CHARACTER PROGRAM DATA> UI3200 3,200 UI _{PP} UI1600 1,600 UI _{PP} UI800 800 UI _{PP} UI80 80 UI _{PP} UI40 40 UI _{PP} UI20 20 UI _{PP} UI05 0.5 UI _{PP}
Function	Performs setting of the transmission jitter generation range.
Restriction	Effective when transmission jitter is generated. Restrictions on setting apply depending on the Bit Rate.

Bit Rate	UI Range
10 G	3,200, 80, 0.5 UI
5 G	1,600, 40, 0.5 UI
2.5 G	800, 20, 0.5 UI

Example of use	Sets the transmission jitter generation range at 0.5 UI _{PP} . > : SOURce : JITTer : RANGe UI05
----------------	---

: SUORce : JITTer : RANGe?

Command type	Transmission sequential command
Response	<range> = <CHARACTER RESPONSE DATA>
Function	Makes a query of the transmission jitter generation range.
Restriction	Effective when jitter is generated. Restrictions on setting apply depending on the Bit Rate.

Bit Rate	UI Range
10 G	3,200, 80, 0.5 UI
5 G	1,600, 40, 0.5 UI
2.5 G	800, 20, 0.5 UI

Example of use > : SOURce : JITTer : RANGe?
 < UI05

: SUORce : JITTer : AMPLitude?

Command type	Sequential command
Response	<string> = <STRING RESPONSE DATA>
Function	Performs reading of the value of Tx JITTER AMPLitude.
Example of use	< : SOURce : JITTer : AMPLitude? > 1.51

Section 8 Device Message Details

8.3.3 SENSE Subsystem

The SENSE subsystem performs control (setting and display) of measurement conditions and reception side.

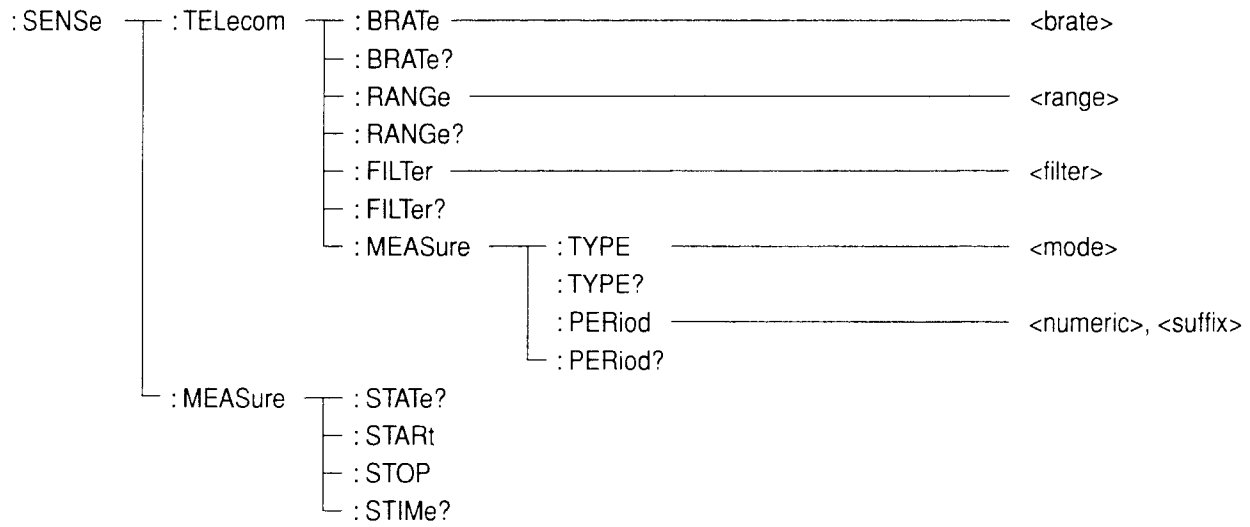

: SENSE : TELecom : BRATe <brate>

Command type	Sequential command																																
Parameter	<brate> = <CHARACTER PROGRAM DATA>																																
	<table border="0"> <tr> <td>(Standard)</td> <td>(Option 05)</td> </tr> <tr> <td>M2488 2,488 Mbit/s</td> <td>M3069 3,069 Mbit/s</td> </tr> <tr> <td>M4977 4,977 Mbit/s</td> <td>M6138 6,138 Mbit/s</td> </tr> <tr> <td>M9953 9,953 Mbit/s</td> <td>M12276 12,276 Mbit/s</td> </tr> <tr> <td>(Option 01)</td> <td>(Option 06)</td> </tr> <tr> <td>M2494 2,494 Mbit/s</td> <td>M2677 2,677 Mbit/s</td> </tr> <tr> <td>M4988 4,988 Mbit/s</td> <td>M5355 5,355 Mbit/s</td> </tr> <tr> <td>M9977 9,977 Mbit/s</td> <td>M10709 10,709 Mbit/s</td> </tr> <tr> <td>(Option 02)</td> <td>(Option 07)</td> </tr> <tr> <td>M2666 2,666 Mbit/s</td> <td>M2578 2,578 Mbit/s</td> </tr> <tr> <td>M5332 5,332 Mbit/s</td> <td>M5156 5,156 Mbit/s</td> </tr> <tr> <td>M10664 10,664 Mbit/s</td> <td>M10313 10,313 Mbit/s</td> </tr> <tr> <td>(Option 04)</td> <td></td> </tr> <tr> <td>M3062 3,062 Mbit/s</td> <td></td> </tr> <tr> <td>M6125 6,125 Mbit/s</td> <td></td> </tr> <tr> <td>M12249 12,249 Mbit/s</td> <td></td> </tr> </table>	(Standard)	(Option 05)	M2488 2,488 Mbit/s	M3069 3,069 Mbit/s	M4977 4,977 Mbit/s	M6138 6,138 Mbit/s	M9953 9,953 Mbit/s	M12276 12,276 Mbit/s	(Option 01)	(Option 06)	M2494 2,494 Mbit/s	M2677 2,677 Mbit/s	M4988 4,988 Mbit/s	M5355 5,355 Mbit/s	M9977 9,977 Mbit/s	M10709 10,709 Mbit/s	(Option 02)	(Option 07)	M2666 2,666 Mbit/s	M2578 2,578 Mbit/s	M5332 5,332 Mbit/s	M5156 5,156 Mbit/s	M10664 10,664 Mbit/s	M10313 10,313 Mbit/s	(Option 04)		M3062 3,062 Mbit/s		M6125 6,125 Mbit/s		M12249 12,249 Mbit/s	
(Standard)	(Option 05)																																
M2488 2,488 Mbit/s	M3069 3,069 Mbit/s																																
M4977 4,977 Mbit/s	M6138 6,138 Mbit/s																																
M9953 9,953 Mbit/s	M12276 12,276 Mbit/s																																
(Option 01)	(Option 06)																																
M2494 2,494 Mbit/s	M2677 2,677 Mbit/s																																
M4988 4,988 Mbit/s	M5355 5,355 Mbit/s																																
M9977 9,977 Mbit/s	M10709 10,709 Mbit/s																																
(Option 02)	(Option 07)																																
M2666 2,666 Mbit/s	M2578 2,578 Mbit/s																																
M5332 5,332 Mbit/s	M5156 5,156 Mbit/s																																
M10664 10,664 Mbit/s	M10313 10,313 Mbit/s																																
(Option 04)																																	
M3062 3,062 Mbit/s																																	
M6125 6,125 Mbit/s																																	
M12249 12,249 Mbit/s																																	
Function	Sets the sign speed of receiving signal.																																
Restriction	Sending the command while the option above is not set results in a run time error.																																
Example of use	Sets the sign speed of the reception signal to 9,953 Mbit/s. > : SENSE : TELecom : BRATe M9953																																

: SENSE : TELecom : BRATe?

Command type	Sequential command
Response	<brate> = <CHARACTER RESPONSE DATA>
Function	Makes a query of the sign speed of the reception signal.
Example of use	> : SENSE : TELecom : BRATe? < M9953

Section 8 Device Message Details

: SENSE : TELEcom : RANGe <range>

Command type	Sequential command
Parameter	<range> = <CHARACTER PROGRAM DATA> UI4 4 UI _{PP} UI1 1 UI _{PP}
Function	Sets the measurement range of receiving jitter.
Example of use	Sets the measurement range of receiving jitter at 1 UI _{PP} . > : SENSE : TELEcom : RANGe UI1

: SENSE : TELEcom : RANGe?

Command type	Sequential command
Response	<range> = <CHARACTER RESPONSE DATA>
Function	Makes a query of receiving jitter measurement.
Example of use	> : SENSE : TELEcom : RANGe? < UI1

: SENSE : TELEcom : FILTer <filter>

Command type	Sequential command
Parameter	<filter> = <CHARACTER PROGRAM DATA> LP LP (80 M) HP1LP HP1+LP (10 K to 80 M) HP1SLP HP1'+LP (20 K to 80 M) HP2LP HP2+LP (4 M to 80 M) HP3LP HP3+LP (6 M to 80 M) HPLP HP+LP (12 K to 80 M) HPSLP HP'+LP (50 K to 80 M)
Function	Performs filter setting.
Restriction	HP'+LP, HP1'+LP setting is disabled when the Bit Rate is set at 2.5 G or 5 G. HP3+LP can be set only for Option 07.
Example of use	Sets the filter at HP'+LP, HP1'+LP. > : SENSE : TELEcom : FILTer HPSLP

: SENSE : TELEcom : FILTER?

Command type	Sequential command
Response	<filter> = <CHARACTER RESPONSE DATA>
Function	Makes a query of the filter setting.
Restriction	HP'+LP, HP1'+LP setting is disabled when the Bit Rate is set at 2.5 G or 5 G.
Example of use	> : SENSE : TELEcom : FILTER? < HP1SLP

: SENSE : TELEcom : MEASure : TYPE <mmode>

Command type	Sequential command
Parameter	<mmode> = <CHARACTER PROGRAM DATA> MANual Manual measurement SINGle Single measurement REPeat Repeat measurement
Function	Performs the measurement mode setting.
Example of use	Sets the measurement mode to the repeat measurement. > : SENSE : MEASure : TYPE REPeat

: SENSE : TELEcom : MEASure : TYPE?

Command type	Sequential command
Response	<mmode> = <CHARACTER RESPONSE DATA> MAN Manual measurement SING Single measurement REP Repeat measurement
Function	Makes a query of the measurement mode.
Example of use	> : SENSE : MEASure : TYPE? < REP

Section 8 Device Message Details

: SENSE : TELEcom : MEASure : PERiod <numeric>, <suffix>

Command type	Sequential command
Parameter	<numeric> = <DECIMAL NUMERIC PROGRAM DATA> 1 to 99 <suffix> = <CHARACTER PROGRAM DATA> H hour M minute S second
Function	Performs the measurement time setting.
Restriction	The setting is disabled when the measurement mode is set to manual measurement.
Example of use	Sets the measurement time at one hour. > : SENSE : TELEcom : MEASure : PERiod 1, H

: SENSE : TELEcom : MEASure : PERiod?

Command type	Sequential command
Response	<numeric>, <suffix> <numeric> = <NR1 NUMERIC RESPONSE DATA> <suffix> = <CHARACTER RESPONSE DATA>
Function	Makes a query of the measurement time.
Example of use	> : SENSE : TELEcom : MEASure : PERiod? < 1, H

: SENSE : MEASure : STATE?

Command type	Sequential command
Response	<mestype>, <numeric> <mestype> = <CHARACTER RESPONSE DATA> MAN Manual measurement NON No target measurement found <numeric> = <NR1 NUMERIC RESPONSE DATA> 0 Measurement completed 1 Measurement currently being performed
Function	Makes a query of the measurement status.
Restriction	Measurement of only one item enabled to be executed. When no measurement is performed, the following indication is output. < NON, 0
Example of use	> : SENSE : MEASure : STATE? < MAN, 1

: SENSE : MEASure : START

Command type	Sequential command
Parameter	None
Function	Begins measurement.
Example of use	Begins measurement. > : SENSE : MEASure : START

: SENSE : MEASure : STOP

Command type	Sequential command
Parameter	None
Function	Halts measurement currently being executed.
Restriction	None
Example of use	> : SENSE : MEASure : STOP

Section 8 Device Message Details

: SENSE : MEASure : STIME?

Command type	Sequential command
Response	<year>, <month>, <day>, <hour>, <min>, <sec> = <NR1 NUMERIC RESPONSE DATA>
Function	Makes a query of the time to start the measurement.
Restriction	The clock can be set within the range between the year 1993 and 2093. When a query is made while the measurement has yet to be started, the time to start measurement previously set will be applied.
Example of use	> : SENSE : MEASure : STIME? < 1996, 2, 5, 12, 12, 12

8.3.4 DISPlay Subsystem

The DISPlay subsystem performs control (setting and display) of screens.

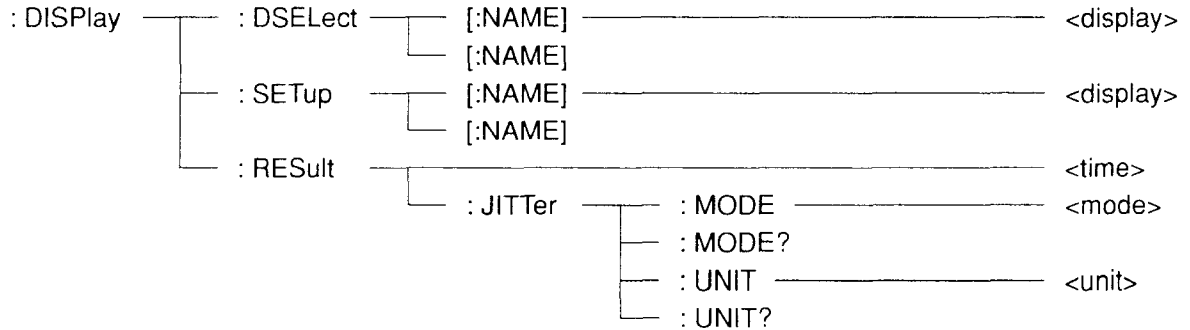

: DISPlay : DSElect [:NAME] <display>

Command type	Sequential command
Parameter	<display> = <STRING PROGRAM DATA> "SETup" Setup screen "TMENu" Test menu screen "RESult" Result screen "T&R" Test menu & Result screen
Function	Selects the screen dividing method.
Example of use	Selects the split screen display of the Test menu screen and Result screen. > : DISPlay : DSElect : MANE "T&R" or : DISPlay : DSElect "T&R"

: DISPlay : DSElect [:NAME]?

Command type	Sequential command
Response	<display> = <STRING RESPONSE DATA> "SET" Setup screen "TMEN" Test menu screen "RES" Result screen "T&R" Test menu & Result screen
Function	Makes a query of the screen dividing status.
Example of use	> : DISPlay : DSElect : NAME? or : DISPlay : DSElect? < "T&R"

Section 8 Device Message Details

: DISPlay : SETUp [:NAME] <sdisplay>

Command type	Sequential command
Parameter	<sdisplay> = <STRING PROGRAM DATA> "INTerface" Interface screen "MEMory" Memory screen "SYSTem" System screen
Function	Selects display item on the Setup screen.
Example of use	Selects "INTerface" from the display items on the Setup screen. > : DISPlay : SETUp : NAME "INTerface" or : DISPlay : SETUp "INTerface"

: DISPlay : SETUp [:NAME]?

Command type	Sequential command
Response	<sdisplay> = <STRING RESPONSE DATA> "INT" Interface screen "MEM" Memory screen "SYST" System screen
Function	Makes a query of the display item on the Setup screen.
Example of use	> : DISPlay : SETUp : NAME? or : DISPlay : SETUp? < "INT"

: DISPlay : RESult : JITTer : MODE <mode>

Command type	Sequential command
Parameter	<mode> = <CHARACTER PROGRAM DATA> CURRent Current display LAST LAST display
Function	Switches the display mode of the Result screen.
Example of use	Sets the display mode to the Current display. > : DISPlay : RESult : JITTer : Mode CURRent

: DISPlay : RESult : JITTer : MODE?

Command type	Sequential command
Response	<mode> = <CHARACTER RESPONSE DATA>
Function	Makes a query of the display mode of the Result screen.
Example of use	> : DISPlay : RESult : JITTer : MODE? < CURR

: DISPlay : RESult : JITTer : UNIT <unit>

Command type	Sequential command
Parameter	<unit> = <CHARACTER PROGRAM DATA> PEAK PEAK detection RMS RMS detection
Function	Sets the format of data to be displayed on the Result screen.
Example of use	Sets the format of data to be displayed on the Result screen at Peak. > : DISPlay : RESult : JITTer : UNIT PEAK

: DISPlay : RESult : JITTer : UNIT?

Command type	Sequential command
Response	<unit> = <CHARACTER RESPONSE DATA>
Function	Makes a query of the format of data to be displayed on the Result screen.
Example of use	> : DISPlay : RESult : JITTer : UNIT? < PEAK

Section 8 Device Message Details

8.3.5 CALCulate Subsystem

The CALCulate subsystem performs the performance measurement setting and measured result display.

: CALCulate _____ : DATA? _____ <string>

: CALCulate : DATA? <string>

Command type	Sequential command
Parameter	<string> = <STRING PROGRAM DATA>
Response	<string> = <STRING RESPONSE DATA> See the Table 8-1 for <string>.
Function	Reads the measured results.
Example of use	> : CALCulate : DATA? "CURRent : JAMPlitude : PTPeak" < 1.00

Table 8-1 String

Item	<string>	Response Format
Jitter manual measurement		
CURRent		
Peak to Peak	"[CURRent:] JAMPlitude : PTPeak"	Form 6
+Peak	"[CURRent:] JAMPlitude : PPEak"	Form 6
-Peak	"[CURRent:] JAMPlitude : MPEak"	Form 6
RMS	"[CURRent:] JAMPlitude : RMS"	Form 6
LAST		
Peak to Peak	"LAST : JAMPlitude : PTPeak"	Form 6
+Peak	"LAST : JAMPlitude : PPEak"	Form 6
-Peak	"LAST : JAMPlitude : MPEak"	Form 6
RMS	"LAST : JAMPlitude : RMS"	Form 6

8.3.6 SYSTem Subsystem

The SYSTem subsystem performs control (setting and display) of memory, buzzer and other items.

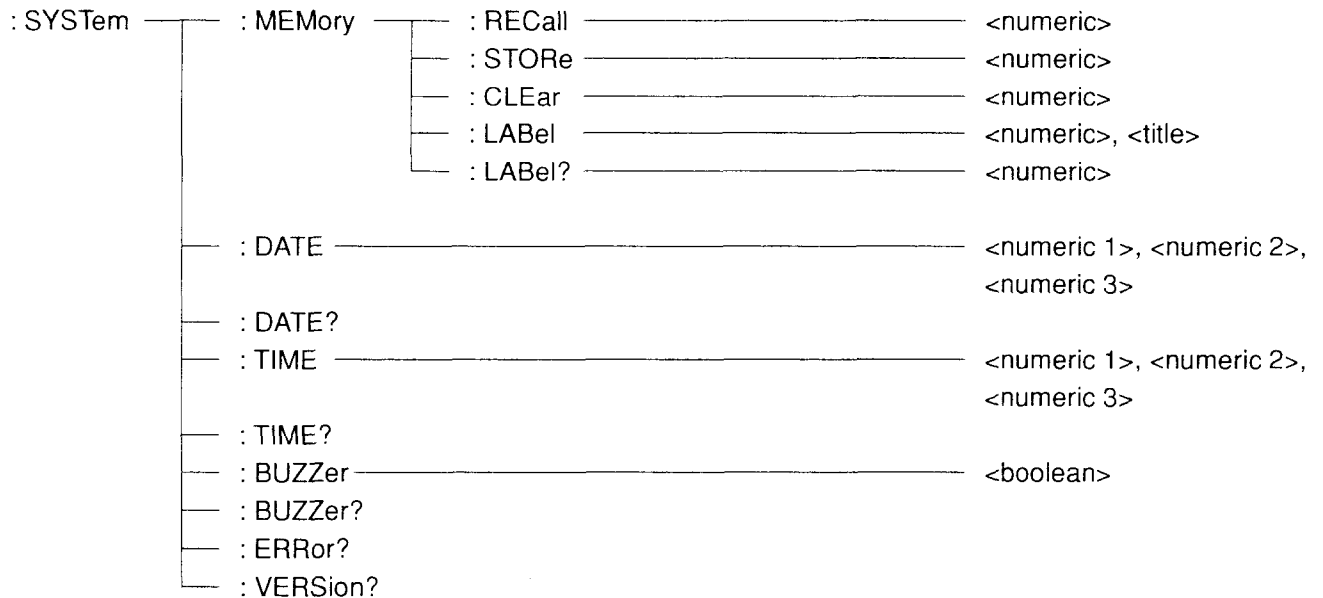

: SYSTem : MEMory : RECall <numeric>

Command type	Sequential command
Parameter	<numeric> = <DECIMAL NUMERIC PROGRAM DATA> 0 to 10 Memory number 0 to Memory number 10
Function	Calls the set data from memory.
Restriction	Specifying a memory number where no data is written will result in a run time error.
Example of use	Calls data from memory number 1. > : SYSTem : MEMory : RECall 1

: SYSTem : MEMory : STORe <numeric>

Command type	Sequential command
Parameter	<numeric> = <DECIMAL NUMERIC PROGRAM DATA> 1 to 10 Memory number 0 to Memory number 10
Function	Writes set data into memory.
Example of use	Writes data into memory number 3. > : SYSTem : MEMory : STORe 3

Section 8 Device Message Details

: SYSTem : MEMory : CLear <numeric>

Command type	Sequential command
Parameter	<numeric> = <DECIMAL NUMERIC PROGRAM DATA> 1 to 10 Memory number 1 to Memory number 10
Function	Deletes set data in memory.
Restriction	Specifying a memory number where no data is written will result in a run time error.
Example of use	Deletes data of memory number 3. > : SYSTem : MEMory : CLear 3

: SYSTem : MEMory : LABel <numeric>, <title>

Command type	Sequential command
Parameter	<numeric> = <DECIMAL NUMERIC PROGRAM DATA> 1 to 10 Memory number 1 to Memory number 10 <title> = <STRING PROGRAM DATA> A maximum of 15 characters (excluding the quotation marks) "Name of memory"
Function	Writes in the name of memory for set data.
Example of use	Sets the name of memory number 1 at "2488 M test." > : SYSTem : MEMory : LABel 1, "2488 M test"

: SYSTem : MEMory : LABel? <numeric>

Command type	Sequential command
Parameter	<numeric> = <DECIMAL NUMERIC PROGRAM DATA> 1 to 10 Memory number 1 to Memory number 10 Response <title> = <STRING RESPONSE DATA> A maximum of 15 characters (excluding the quotation marks)
Function	Makes a query of the name of the memory for set data.
Example of use	Makes a query of the name of memory number 1. > : SYSTem : MEMory : LABel? 1 < "2488 M test"

: SYSTem : DATE <numeric1>, <numeric2>, <numeric3>

Command type	Sequential command
Parameter	<DECIMAL NUMERIC PROGRAM DATA> <numeric1> = 1993 to 2092 (year) <numeric2> = 1 to 12 (month) <numeric3> = 1 to 31 (day)
Function	Sets the current date.
Example of use	Sets the current date at May 28, 1995. > : SYSTem : DATE 1995,5,28

: SYSTem : DATE?

Command type	Sequential command
Response	<numeric1>, <numeric2>, <numeric3> = <NR1 NUMERIC RESPONSE DATA>
Function	Makes a query of the current date.
Example of use	> : SYSTem : DATE? < 1995,5,28

: SYSTem : TIME <numeric1>, <numeric2>, <numeric3>

Command type	Sequential command
Parameter	<DECIMAL NUMERIC PROGRAM DATA> <numeric1> = 0 to 23 (hour) <numeric2> = 0 to 59 (minute) <numeric3> = 0 to 59 (second)
Function	Sets the current time.
Example of use	Sets the current time at 14:00:00. > : SYSTem : TIME 14,0,0

: SYSTem : TIME?

Command type	Sequential command
Response	<numeric1>, <numeric2>, <numeric3> = <NR1 NUMERIC RESPONSE DATA>
Function	Makes a query of the current time.
Example of use	> : SYSTem : TIME? < 14,0,0

Section 8 Device Message Details

: SYSTem : BUZZer <boolean>

Command type	Sequential command
Parameter	<boolean> = <BOOLEAN PROGRAM DATA> OFF or 0 Buzzer OFF ON or 1 Buzzer ON
Function	Switches the buzzer ON and OFF.
Example of use	Switches the buzzer ON. < : SYSTem : BUZZer ON

: SYSTem : BUZZer?

Command type	Sequential command
Response	<NR1 NUMERIC RESPONSE DATA> 0 Buzzer OFF 1 Buzzer ON
Function	Makes a query of the buzzer setting status.
Example of use	> : SYSTem : BUZZer? < 1

: SYSTem : ERRor?

Command type	Sequential command
Response	<error/event_number>, <error/event_description> <error/event_number> = <NR1 NUMERIC RESPONSE DATA> -32,768 to 32,767 <error/event_description> = <STRING RESPONSE DATA>
Example of use	> : SYSTem : ERRor? < -102, "Syntax error"

: SYSTem : VERSion?

Command type	Sequential command
Response	<version> <version> = <NR2 NUMERIC RESPONSE DATA> YYYY.V YYYY (year), V (revision number)
Function	Makes a query of the version of SCPI to which this device conforms.
Example of use	> : SYSTem : VERSion? < 1993.0

8.3.7 STATus Subsystem

The STATus subsystem performs control (setting and display) of the status registers.

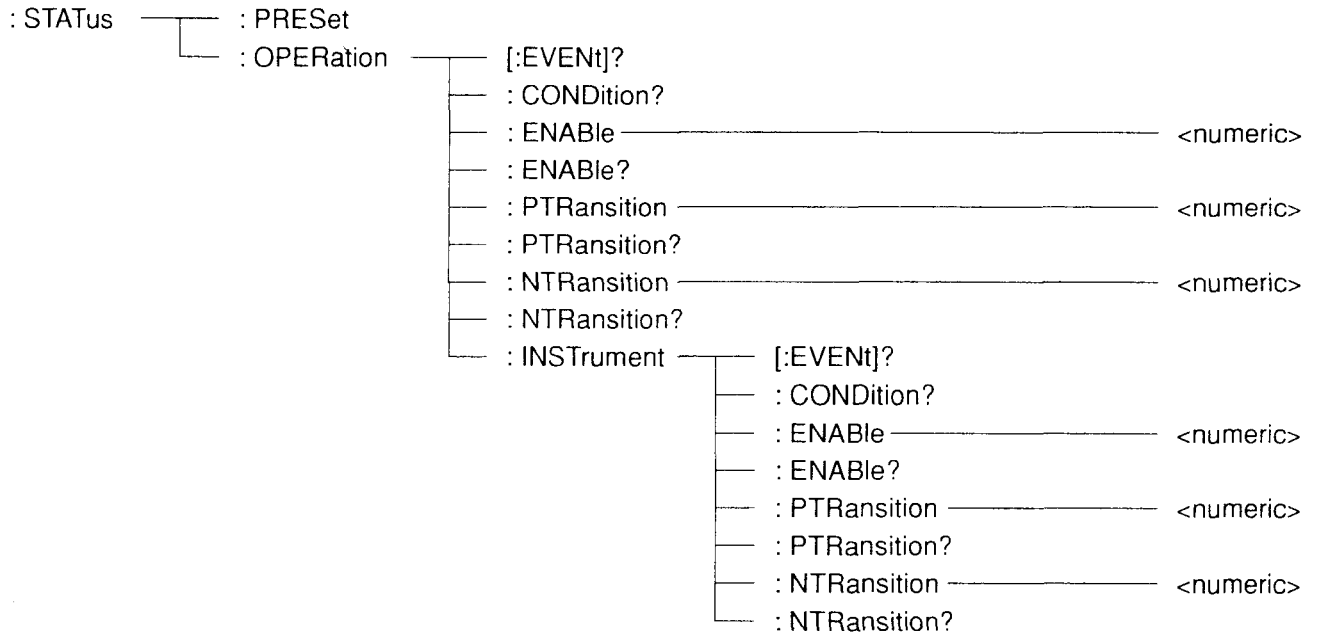

: STATus : PRESet

Command type	Sequential command
Parameter	None
Function	Initializes status registers. See the Section 6 "Status Report".
Example of use	> : STATus : PRESet

: STATus : OPERation [:EVENT]?

Command type	Sequential command
Response	<numeric> = <NR1 NUMERIC RESPONSE DATA> 0 to 32,767 Sum (decimal digit) of event register bits
Function	Makes a query of the details of the event register of the OPERation status event register.
Example of use	When the INSTRument status register summary bit of the OPERation status event register is ON. > : STATus : OPERation : EVENT? < 8192

Section 8 Device Message Details

: STATus : OPERation : CONDition?

Command type	Sequential command
Response	<numeric> = <NR1 NUMERIC RESPONSE DATA> 0 to 32,767 Sum (decimal digit) of condition register bits
Function	Makes a query of the details of the condition register of the OPERation status register.
Example of use	When the bit being measured of the OPERation status register is ON (measurement being performed). > : STATus : OPERation : CONDition? < 16

: STATus : OPERation : ENABLE <numeric>

Command type	Sequential command
Parameter	<numeric> = <DECIMAL NUMERIC PROGRAM DATA> 0 to 32,767 Sum (decimal digit) of event enable register bits
Function	Sets the masking value of the event enable register of the OPERation status register. Masking at 0.
Example of use	Sets the masking value in a manner that when the bit being measured of the event register switches ON, it will be reported to the status byte register. > : STATus : OPERation : ENABLE 16

: STATus : OPERation : ENABLE?

Command type	Sequential command
Response	<numeric> = <NR1 NUMERIC RESPONSE DATA> 0 to 32,767 Sum (decimal digit) of event enable register bits
Function	Makes a query of the details of the event enable register of the OPERation status register.
Example of use	When only the bit being measured is enabled. > : STATus : OPERation : ENABLE? < 16

: STATus : OPERation : PTRansition <numeric>

Command type	Sequential command
Parameter	<numeric> = <DECIMAL NUMERIC PROGRAM DATA> 0 to 32,767 Sum (decimal digit) of transition filter bits
Function	Sets the transition filter (a change in the positive direction) of the OPERation status register. Set at 1.
Example of use	Sets the bit being measured at PTRansition. > : STATus : OPERation : PTRansition 16

: STATus : OPERation : PTRansition?

Command type	Sequential command
Response	<numeric> = <NR1 NUMERIC RESPONSE DATA> 0 to 32,767 Sum (decimal digit) of transition filter bits
Function	Makes a query of the details of the transition filter (a change in the positive direction) of the OPERation status register.
Example of use	When the bit being measured is set at PTRansition. > : STATus : OPERation : PTRansition? < 16

: STATus : OPERation : NTRansition <numeric>

Command type	Sequential command
Parameter	<numeric> = <DECIMAL NUMERIC PROGRAM DATA> 0 to 32,767 Sum (decimal digit) of transition filter bits
Function	Sets the transition filter (a change in the negative direction) of the OPERation status register. Set at 1.
Example of use	Sets the INSTRument status register summary at NTRansition. > : STATus : OPERation : NTRansition 8192

Section 8 Device Message Details

: STATus : OPERation : NTRansition?	
Command type	Sequential command
Response	<numeric> = <NR1 NUMERIC RESPONSE DATA> 0 to 32,767 Sum (decimal digit) of transition filter bits
Function	Makes a query of the details of the transition filter (a change in the negative direction) of the OPERation status register.
Example of use	When the INSTRument status register summary bit is set at NTRansition. > : STATus : OPERation : NTRansition? < 8192

: STATus : OPERation : INSTRument [:EVENT]?	
Command type	Sequential command
Response	<numeric> = <NR1 NUMERIC RESPONSE DATA> 0 to 32,767 Sum (decimal digit) of event register bits
Function	Makes a query of the details of the event register of the INSTRument status register.
Example of use	When the alarm change bit is ON. > : STATus : OPERation : INSTRument : EVENT? < 16

: STATus : OPERation : INSTRument : CONDition?	
Command type	Sequential command
Response	<numeric> = <NR1 NUMERIC RESPONSE DATA> 0 to 32,767 Sum (decimal digit) of condition register bits
Function	Makes a query of the details of the condition register of the INSTRument status register.
Example of use	When the alarm change bit of the condition register of the INSTRument register is ON. > : STATus : OPERation : INSTRument : CONDition? < 16

: STATus : OPERation : INSTRument : ENABle <numeric>

Command type	Sequential command
Parameter	<numeric> = <DECIMAL NUMERIC PROGRAM DATA> 0 to 32,767 Sum (decimal digit) of event enable register bits
Function	Sets the masking value of the event enable register of the INSTRument register. Masking at 0.
Example of use	Sets the masking value in a manner that when the bit of alarm change of the event register switches ON, it will be reported to the OPERation register. > : STATus : OPERation : INSTRument : ENABle 16

: STATus : OPERation : INSTRument : ENABle?

Command type	Sequential command
Response	<numeric> = <NR1 NUMERIC RESPONSE DATA> 0 to 32,767 Sum (decimal digit) of event enable register bits
Function	Makes a query of the details of the event enable register of the INSTRument register.
Example of use	When only the bit of alarm change is enabled. > : STATus : OPERation : INSTRument : ENABle? < 16

: STATus : OPERation : INSTRument : PTRansition <numeric>

Command type	Sequential command
Parameter	<numeric> = <DECIMAL NUMERIC PROGRAM DATA> 0 to 32,767 Sum (decimal digit) of transition filter bits
Function	Sets the transition filter (a change in the positive direction) of the INSTRument status register. Set at 1.
Example of use	Sets the bit of measurement completion at PTRansition. > : STATus : OPERation : INSTRument : PTRansition 2

Section 8 Device Message Details

: STATus : OPERation : INSTRument : PTRansition?

Command type	Sequential command
Response	<numeric> = <NR1 NUMERIC RESPONSE DATA> 0 to 32,767 Sum (decimal digit) of transition filter bits
Function	Makes a query of the details of the transition filter (a change in the positive direction) of the INSTRument status register.
Example of use	When the bit of measurement completion is set at PTRansition. > : STATus : OPERation : INSTRument : PTRansition? < 2

: STATus : OPERation : INSTRument : NTRansition <numeric>

Command type	Sequential command
Parameter	<numeric> = <DECIMAL NUMERIC PROGRAM DATA> 0 to 32,767 Sum (decimal digit) of transition filter bits
Function	Sets the transition filter (a change in the negative direction) of the INSTRument status register. Set at 1.
Example of use	Sets the bit of measurement completion at NTRansition. > : STATus : OPERation : INSTRument : NTRansition 2

: STATus : OPERation : INSTRument : NTRansition?

Command type	Sequential command
Response	<numeric> = <NR1 NUMERIC RESPONSE DATA> 0 to 32,767 Sum (decimal digit) of transition filter bits
Function	Makes a query of the details of the transition filter (a change in the negative direction) of the INSTRument status register.
Example of use	When the bit of measurement completion is set at NTRansition. > : STATus : OPERation : INSTRument : NTRansition? < 2

Appendix A SCPI Error Messages

SCPI specifies codes and messages to correspond to errors as responses to the SCPI command, :SYSTem:ERRor?. The following section provides detailed explanations of error messages supported by this device.

A.1 Command Errors	A-2
A.2 Run Time Errors	A-4
A.3 Device-Specific Errors	A-5
A.4 Query Errors	A-6

Appendix A SCPI Error Messages

A.1 Command Errors

The error codes, [-199 and -100], indicate that syntax errors of IEEE488.2 have taken place. In this case, bit 5 of the event status register of the device is set.

Errors take place when the following events take place.

- When the device has received a message in violation of the IEEE488.2 standards.
- When the device has received a header that does not conform to the stipulations of the device-specific commands or common commands.
- When GET (Group Execute Trigger) is sent to the program message.

Table A-1 Error Messages of Command Errors

Code	Message	Error Detection Condition
-101	Invalid character	An invalid character is included in the header or the parameter. <i>Example:</i> 1. A # is included in the header. :SENSe:TELEcom:#RATE M139 2. A \$ is included in the parameter. :SENSe:TELEcom:PATTErn:TYPE PRB\$11
-104	Data type error	The parameter type is different to the type specified.
-105	GET not allowed	A Group Execute Trigger was sent to the program message.
-108	Parameter not allowed	The number of parameters is greater than the number specified. <i>Example:</i> Four parameter have been sent to the Section where two parameters were originally specified. :SENSe:TELEcom:DEMUx:ROUte M34,1,M8,2
-112	Program mnemonic too long	A program mnemonic comes in 12 or more characters. <i>Example:</i> A colon is missing from the header. :CALCulate:TELEcom:PERFormanceTYPE G821
-113	Undefined header	Although the header syntax is correct, it is not defined by the device. <i>Example:</i> The header was erroneously written. :SENSe:TELEcom:DEMUx:ROOT M34,1
-120	Numeric data error	An error was found in the numeric data.
-121	Invalid character in number	An inappropriate character is included in the numeric data. <i>Example:</i> A sign is included in the numeric data. :SENSe:TELEcom:M2:MCHannel 3\$
-130	Suffix error	An error was found in the suffix. <i>Example:</i> A part of data was set in alphabet while the parameter is numeric data. :SENSe:TELEcom:M2:MCHannel 3I
-144	Character data too long	The character data is more than 12 characters.
-150	String data error	The string data comes outside the specified range. <i>Example:</i> Single and double quotations are mixed. :DISPlay:MENU:NAME "SYSTem"

A.2 Run Time Errors

The error codes, [-299 and -200], indicate that errors have taken place in the execution controller. In this case, bit 4 of the event status register is set.

Errors take place when the following events take place.

- When the <PROGRAM DATA> to follow the header comes outside the specified range.
- The program message cannot be executed because of the device status.

Table A-2 Error Messages of Run Time Errors

Code	Message	Error Detection Condition
-220	Parameter error	An error was found in the parameter.
-221	Setting conflict	Although the setting is correct as a parameter, it cannot be set because of the device status. <i>Example:</i> A self-diagnosis was attempted during measurement. A rate greater than that of the interface was specified as the final MUX stage.
-222	Data out of range	The numeric data has exceeded the device specifications. <i>Example:</i> SENSE : MEASure : PERiod 0, s : SYSTem : MEMory : STORe 25
-223	Too much data	The length of the string data has exceeded the specified length. <i>Example:</i> The following setting was used when word data of 16 characters was specified. : SENSE : TELEcom : PATtern : UWORd "11001100110011001"
-224	Illegal parameter value	Using the parameter received is disabled. <i>Example:</i> 1. The character data comes outside the specified range. : SENSE : TELEcom : BRATe M15 2. The string data comes outside the specified range. : CALCulate : DATA? "LAST : EC : CMI"
-240	Hardware error	The command cannot be executed because of hardware failure.
-241	Hardware missing	The command cannot be executed because the option is not mounted.

A.3 Device-Specific Errors

The error codes, [-399 and -300], indicate that the device encountered errors other than the command error, query error and run time error. Device-specific errors include errors such as hardware and firmware errors and self-diagnosis error. When a device-specific error takes place, bit 3 of the event status register is set.

Table A-3 Error Messages of Device-Specific Errors

Code	Message	Error Detection Condition
-310	System error	A system error has taken place.
-314	Save/recall memory lost	The local memory has been lost.
-315	Configuration memory lost	The resume memory has been lost.

NOTE :

The self-test includes a self test conducted at the power activation.

A.4 Query Errors

The error codes, [-499 and -400], indicate that the output control queue of the device has encountered errors related to the message exchange control protocol. When these errors take place, bit 2 of the event status register of the device is set.

Errors take place when the following events take place.

- Reading from the output queue was attempted in the absence of output.
- The data of the output queue has been lost.

Table A-4 Error Messages of Query Errors

Code	Message	Error Detection Condition
-410	Query INTERRUPTED	Before the device finishes sending a response message, an interrupt by a new command has taken place. <i>Example:</i> *TRG was sent before sending of a response has fully been completed.
-420	Query UNTERMINATED	A query to correspond to the response message to be read has not been sent. Or the query has completely been terminated.
-430	Query DEADLOCKED	Data greater in size than the storage area has been attempted to be stored into the buffer. <i>Example:</i> The device is unable to continue measurement because the input and output buffers are both full.

Appendix B

Details of Initialization Command Functions

This section provides explanations of the range of effects of each initialization command on the device.

B.1	Initializing Bus	B-2
B.2	Initializing Message	B-3
B.3	Initializing Device	B-4
B.4	Device Status at Power Activation	B-5

Appendix B Details of Initialization Command Functions

B.1 Initializing Bus

IFC: Initializes functions of all the devices connected to the GPIB bus line, when the GPIB option is mounted.

Initialization of the interface function refers to an action of canceling the status of the interface function of the device set by the controller and returning it to the initial status. Each function marked with a check mark (√) in the table is initialized. The function marked with a delta (Δ) means that the function will be partially initialized. This command has no effects on the operation status of the device.

Table B-1 Changes in Status of Interface Functions by IFC Message

No.	Function	Cord	Initialization by IFC
1	Source handshake	SH	√
2	Acceptor handshake	AH	√
3	Talker or extension talker	T or TE	√
4	Listener or extension listener	L or LT	√
5	Service request	SR	Δ
6	Remote local	RL	
7	Parallel port	PP	
8	Device clear	DC	
9	Device trigger	DT	
10	Controlle	C	√

The following table shows changes in status of the device by the IFC message.

Table B-2 Changes in Status of Device by IFC Message

IFC Message	Changes in Status of Device
Talker/Listener	All the talkers and listeners switch into the idle state (TIDS and LIDS) within 100 μs.
Controller	Unless the controller is active (SACS: System control ACtive State), the controller switches into the idle state (CIDS: Control IDle State) within 100 μs.
Device of service request	Although the state where the device is sending an SRQ message to the controller (state where the SRQ line is set by the device to the LOW level) is not canceled, the message cancels the state where the controller have all the devices under the system bus in the serial pole mode.
Device in remote mode	Devices currently in the remote mode will not be released from the remote mode by the IFC message.

B.2 Initializing Message

DCL, SDC: Initializes the message exchange among all the devices on GPIB or only specified devices, When a GPIB option is mounted.

The following table shows target items of message exchange initialization.

Table B-3 Items of Initialization Target of Message Exchange

Item	Effects of Initialization
Input and output buffers	Input and output buffers will be cleared.
Syntax analyzer, run time controller and response production module	The syntax analyzer, run time controller, and response production module will be reset.
Device command including *RST	All the commands to interfere with the execution of these commands will be cleared.
Program message to the parameter	All the commands and queries of the Section, where execution is postponed for the parameter, will be discarded.
Processing of the *OPC command	Switches the device into the OCIS (Operation Complete Command Idle State). As a result, operation completion bit will not be set in the standard event status register.
Processing of the OPC? query	Switches the device into the OQIS (Operation Complete Query Idle State). As a result, the operation completion bit 1 cannot be set in the output queue. The MAV bit will be cleared.
Device function	Sections related to message exchange are all switched into the idle state. The device waits for a message from the controller.

B.3 Initializing Device

***RST:** Initializes the device. (Common to the GPIB and RS-232C options)

The *RST command switches the device into the following state.

- (1) Switches the device-specific functions to the initial state regardless of the past use. On this device, the command switches the functions to the same state as that when the power switch is turned ON.
- (2) Switches the device to the OCIS.
- (3) Switches the device to the OQIS.

The *RST command has no effects on the following items.

- (1) IEEE488.2 interface state
 - (2) Device address
 - (3) Output queue
 - (4) Service request enable register
 - (5) Standard event status enable register
 - (6) Power-on-status-clear flag setting
 - (7) Structure data to have effects on the device standards
 - (8) Macro defined by the DMC command
 - (9) Response message to the PUD query
 - (10) Response message to the RDT query
- (Items 8 to 10 are not supported by this device.)

B.4 Device Status at Power Activation

The device switches into the following state when the power is activated.

- (1) Sets the device to the state where the power was turned OFF the last time.
- (2) Clears the input and output buffers.
- (3) Resets the syntax analyzer, run time controller.
- (4) Switches the device to the OCIS.
- (5) Switches the device to the OCIS.
- (6) Clears all the event status enable registers, when the PSC flag is set true. Records the event after the registers are cleared.

Items related to the Power On Status Clear (PSC) flag

When the PSC flag is false, the service request enable register, standard event status enable register and other status enable register will not be affected. Moreover, when the PSC flag is true or the *PSC command is not executed, the aforementioned registers are cleared.

Appendix B Details of Initialization Command Functions

Head office address was changed

Head office address on the back cover was changed. Please substitute it as the following address.

Anritsu Corporation

1800 Onna, Atsugi-shi, Kanagawa, 243-8555, Japan

TEL: +81-46-223-1111

22 September 2003

Anritsu Service and Sales offices



• Argentina

MULTIRADIO S.A.

Av. Cordoba, 4860 Buenos Aires,
C1414BAT, Argentina
TEL: +55-4779-5522
FAX: +55-4779-5510

• Brazil

ANRITSU ELETRÔNICA LTDA.

Praca Amadeu Amaral, 27-1 Andar
CEP 01327-010 - Sao Paulo - SP, Sao
Paulo, Brazil
TEL: +55-11-3283-2511
FAX: +55-11-2886940

ANRITSU ELETRÔNICA LTDA.

Rua Voluntarios da Patria, 45 13 Andar
Sala 1308,
CEP 222-000 - Rio de Janeiro - RJ, Brazil
TEL: +55-21-2527-6922
FAX: +55-21-2537-1456

• Canada

ANRITSU ELECTRONICS LTD.

(HEADQUARTERS IN OTTAWA OFFICE)

700 Silver Seven Road, Suite 120, Kanata,
ON K2V 1C3, Canada
Toll free: 1-800-ANRITSU (267-4878)
TEL: +1-613-591-2003
FAX: +1-613-591-1006

ANRITSU ELECTRONICS LTD.

(VANCOUVER OFFICE)

300-1055 W Hastings St., Suite 38
Vancouver, BC V6E 2E9, Canada
Toll free: +1-877-267-4878
TEL: +1-604-682-5933
FAX: +1-604-682-5934

ANRITSU ELECTRONICS LTD.

(TORONTO OFFICE)

2810 Matheson Blvd. E, 2nd Fl.,
Mississauga, ON L4W 4X7, Canada
Toll free: +1-877-267-4878
TEL: +1-905-890-7799
FAX: +1-905-625-5864

ANRITSU ELECTRONICS LTD.

(MONTREAL OFFICE)

6600 Transcanada Highway
Suite 750, Pointe Claire, QC H9R 4S2
TEL: +1-514-695-9797
FAX: +1-514-697-0186

• Chile

SISTEMAS DE INSTRUMENTACION LTDA.

Concha y Toro 65, Stgo Centro
Santiago, Chile 51880
TEL: +56-2-6960031
FAX: +56-2-6969665

• Colombia

RENTAMETRIC LTDA.

Calle 24 No. 32-67, Apartado: 23030
Santafe de Bogota, D.C. Colombia
TEL: +57-1-269-6555
FAX: +57-1-269-0191

• Costa Rica

SONIVISION, S.A.

P.O. Box 620-1000, San Jose, Costa Rica
TEL: +506-231-5685
FAX: +506-231-6531

• Ecuador

EQUITRONICS S.A.

Belgica N-32 Hy Av. De Los Shyris,
Edificio IVSEMON PARK, Suite 4B, Quito,
Ecuador
TEL: +593-2-255-396
FAX: +593-2-255-396

• El Salvador

EMPRESA DE COMERCIO EXTERIOR S.A. DE C.V.

Centro Comercial Feria Rosa, Alameda
Dr. Manuel Enrique Araujo, Edificio H,
Local 315 San Salvador, El Salvador
TEL: +503-243-3924
FAX: +503-243-3925

• Guatemala

IMPELSA.

4a Calle 1-15 Zong 10 Guatemala, C.A.
01010, Guatemala
TEL: +502-360-5135
FAX: +502-360-5217

• Mexico

SIHIKATRONICS mmWAVE S.A. DE C.V.

Luz Saviñon 9-701, Col. Del Valle, C.P.
03100, Mexico, D.F., Mexico
TEL: +52-5-5437313
FAX: +52-5-5437317

• Paraguay

DATALAB S.R.L.

Avda. Artigas No 1645 Edificio "DataLab"
Asuncion, Paraguay
TEL: +595-21-20-9126
FAX: +595-21-20-9127

• Peru

ELETELSE S.A.

AV Canaval Moreyra 748, San Isidro,
Lima 27, Peru
TEL: +51-1-224-2514
FAX: +51-1-224-8148

• U.S.A.

ANRITSU COMPANY

1155 East Collins Blvd., Richardson, TX
75081, U.S.A.
Toll Free: +1-800-ANRITSU (267-4878)

TEL: +1-972-644-1777

FAX: +1-972-644-3416

ANRITSU COMPANY

490 Jarvis Drive, Morgan Hill, CA 95037,
U.S.A.

Toll Free: +1-800-ANRITSU (267-4878)

TEL: +1-408-778-2000

FAX: +1-408-778-3180

ANRITSU COMPANY

10 New Maple Ave., Unit 305,
P.O. Box 836, Pine Brook, NJ 07058-0836
U.S.A.

Toll Free: +1-800-ANRITSU (267-4878)

TEL: +1-973-227-8999

FAX: +1-973-575-0092

ANRITSU COMPANY

SALES AND SERVICE, FL OFFICE

312 W. First Street, Suite 300, Sanford,
FL 32771, U.S.A.

Toll Free: 1-800-ANRITSU (267-4878)

TEL: +1-407-321-5130

FAX: +1-407-330-2018

ANRITSU COMPANY

SALES AND SERVICE, GA OFFICE

4625 Alexander Drive, Alpharetta,
GA 30022, U.S.A.

Toll Free: 1-800-ANRITSU (267-4878)

TEL: +1-678-566-0454

FAX: +1-678-566-1776

• Uruguay

CABONORTE S.A.

Colonia 1900, Esc. 603, Montevideo,
Uruguay
TEL: +598-2-430522
FAX: +598-2-418594

• Venezuela

RADIOCOMUNICACIONES CRUZ, C.A.

Calle La Colina Quinta. Elison, Frente al
teatro Alberto Mateo Caracas 1050,
Venezuela
TEL: +58-2-793-2322
FAX: +58-2-793-3429



• Austria

WIEN-SCHALL GmbH

Krichbaumgasse 25, A-1120 Vienna,
Austria
TEL: +43-1-81155140
FAX: +43-1-81155180

• Belgium

ANRITSU GmbH

Grafenberger Allee 54-56, 40237
Düsseldorf, Germany
Local phone: 0800-90001 (toll free)

14 February 2005 L-1

TEL: +49-211-96855-0
FAX: +49-211-96855-55

• **Bulgaria**

ELSINCO Representation OFFICE Sofia
h.e. Strelbishte, str. Kottlenski Prohod,
bl. 96/6/14, BG-1408 Sofia, Bulgaria
TEL: +359-2-958-1245
FAX: +359-2-958-1698

• **Croatia**

ELSINCO REPRESENTATION OFFICE ZAGREB
Savska 66 HR-10000 Zagreb, Croatia
TEL: +385-1-6312-477
FAX: +385-1-6312-488

• **Czech Republic**

ELSINCO PRAHA SPOL S.R.O.
Novodvorská 994, CZ-142 21 Praha,
4-Branik, Czech Republic
TEL: +420-2-4149-0147
FAX: +420-2-4447-2169

**ELSINCO PRAHA SPOL S.R.O.
(BRNO BRANCH OFFICE)**
Strmá 19, CZ-616 00 Brno, Czech
Republic
TEL: +420-5-4142-7211
FAX: +420-5-4142-7219

• **Denmark**

ANRITSU AB DANMARK
Korskildelund 6 DK-2670 Greve, Denmark
TEL: +45 36915035
FAX: +45 43909371

• **Finland**

**ANRITSU AB
(FINLAND BRANCH OFFICE)**
Teknobulevardi 3-5, FI-01530 Vantaa,
Finland
TEL: +358-9-435-522-0
FAX: +358-9-435-522-50

• **France**

ANRITSU S.A.
9 Avenue du Québec, ZA Courtabœuf 1
91951 LES ULIS CEDEX, France
TEL: +33 1 60 92 15 50
FAX: +33 1 64 46 10 65

**ANRITSU S.A.
(TOULOUSE OFFICE)**
Bureau de Toulouse Région Centre Sud
Ouest, France
TEL: +33-5-62070484
FAX: +33-5-62070668

**ANRITSU S.A.
(TOULON OFFICE)**
Bureau de Toulon Région Centre Sud Est,
France
TEL: +33-4-94040264
FAX: +33-4-94040265

**ANRITSU S.A.
(RENNES OFFICE)**
Bureau de Rennes Région Ouest, France
TEL: +33-2-99521214
FAX: +33-2-99521224

• **Germany**

ANRITSU GmbH
Grafenberger Allee 54-56, 40237
Düsseldorf, Germany
TEL: +49-211-96855-0
FAX: +49-211-96855-55

• **Greece**

KOSTAS KARAYANNIS SA
58 Kapodistriou str, GR-142 35 Nea Ionia,
Athens, Greece
TEL: +30-1-680-0460-4
FAX: +30-1-685-3522

• **Hungary**

ELSINCO BUDAPEST KFT
Pannónia utca 8. IV/l., H-1136 Budapest,
Hungary
TEL: +36-1-339-0000
FAX: +36-1-339-4444

• **Ireland**

PEMA LTD.
Dromiskin, Dundalk, Co. Louth, Ireland
TEL: +353-42-72899
FAX: +353-42-72376

• **Italy**

ANRITSU S.P.A.
Via Elio Vittorini 129, 00144 Roma, Italy
TEL: +39-06-509-9711
FAX: +39-06-502-2425

ANRITSU S.P.A.
Via Paracelso 4, CD Colleoni, Agrate
Brianza, 20041 Milano, Italy
TEL: +39-039-657021
FAX: +39-039-6056396

• **Norway**

BLOMKVIST AS
Pb 188, 1371 ASKER, Norway
TEL: + 47 66901190
FAX: + 47 66901212

• **Poland**

ELSINCO POLSKA SP. Z.O.O
ul Gdanska 50, 01-691 Warszawa, Poland
TEL: +48-22-39-832-4042 (Sat Link)
FAX: +48-22-832-2238

• **Portugal**

OMNITECNICA S.A.
Estrada de Alfragide 23, 2720-015
Amadora, Portugal
TEL: +351-21-472-12-00
FAX: +351-21-472-12-70 (Sales)

• **Slovakia**

ELSINCO SLOVENSKO S.R.O
Kudláková 4, SK-844 15 Bratislava,
Slovakia
TEL: +421 7 6428 41 65
FAX: +421 7 6428 44 54

**ELSINCO SLOVENSKO S.R.O
(KOŠICE BRANCH OFFICE)**
Floriánska 16, SK-043 13 Kosice, Slovakia
TEL: +421 95 62 26 729
FAX: +421 95 62 26 729
CONTACT: Mr. Igor Domorak,
Branch Office Manager

• **Slovenia**

ELSINCO D.O.O.
Dalmatinova 2, SI-1000 Ljubljana,
Slovenia
TEL: +386-61-133-62-77
FAX: +386-61-317-397

• **Sweden**

ANRITSU AB
Borgarfjordsgatan 13A, S-164 40 KISTA,
Sweden
TEL: +46-8-534-70700
FAX: +46-8-534-70730

• **United Kingdom**

ANRITSU LTD.
200 Capability Green, Luton, Bedfordshire,
LU1 3LU, U.K.
TEL: (Sales) + 44 1582-433280
(Service) +44 1582-433285
(Other enquiries) +44 1582-433200
FAX: +44 1582-731303



• **Australia**

ANRITSU PTY LTD.
Unit 3/170 Forster Road, Mount. Waverley,
Vic., 3149, Australia
TEL: +61-3-9558-8177
FAX: +61-3-9558-8255

• **Bahrain**

BASMATECH
P. O. Box 5701, Manama, Bahrain
TEL: +973-273729
FAX: +973-725404

• **China**

ANRITSU COMPANY LTD.
Suite 923, 9/F., Chinachem Golden Plaza
77 Mody Road, Tsimshatsui East,
Kowloon, Hong Kong
TEL: +852-2301-4980
FAX: +852-2301-3545

ANRITSU COMPANY LTD.
(BEIJING REPRESENTATIVE OFFICE)
Room 1515, Beijing Fortune Building
No. 5 North Road, the East 3rd Ring Road,
Chao-Yang District, Beijing 100004
P.R. China
TEL: +86-10-6590-9230
FAX: +86-10-6590-9235

ANRITSU COMPANY LTD.
(SHANGHAI OFFICE)
Room 1807-1810, Tower A CITY CENTER
of Shanghai
No. 100 ZunYi Road 200051 P.R.China
TEL: +86-021-6237-0898
FAX: +86-021-6237-0899

ANRITSU COMPANY LTD.
(GUANGZHOU REPRESENTATIVE OFFICE)
Room 3008-9, Dongshan Plaza, 69 Xian
Lie Zong Road Central, Guangzhou
510095, P.R. China
TEL: +86-20-8732 2231/2
FAX: +86-20-8732 2230

ANRITSU COMPANY LTD.
(CHENGDU REPRESENTATIVE OFFICE)
26E New Times Square, No. 42, Wenwu
Road, Xinhua Street, Chengdu 610017
P.R. China
TEL: +86-28-8651 0011/22/33
FAX: +86-28-8651 0055

ANRITSU COMPANY LTD.
(XI'AN REPRESENTATIVE OFFICE)
No.1102, ZhiCheng Building, No.2
Gao Xin I Road, High-Tech, Development
Zone, Xi'an 710075, P.R. China
TEL: +86-29-8377 406/9
FAX: +86-29-8377 410

ANRITSU COMPANY LTD.
(SHENZHEN REPRESENTATIVE OFFICE)
Room 1505, Building A
World Trade Plaza, Fuhong Road
Shenzhen 518033, P.R. China
TEL: +86-755-8366 2847/2851/2852
FAX: +86-755-8366 2849

ANRITSU COMPANY LTD.
(CHONG QING REPRESENTATIVE OFFICE)
Rm.6-2, D Building, Kejifazhan Plaza
No.210, Keyuan 1st Road, Gaoxin District
Shiqiaopu, Chongqing 400010
P.R. China
TEL: +86-23-8909-9918
FAX: +86-23-8909-9928

ANRITSU ELECTRONICS (SHANGHAI) CO., LTD. (SERVICE CENTER)
2F, Room B, 52 Section Factory Building
No. 516 Fu Te North Road
Waigaoqiao Free Trade Zone
Pudong, Shanghai 200131, P.R. China
TEL: +86-21-5868-0226/7/8
FAX: +86-21-5868-0588

ANRITSU COMPANY LTD.
(SHENYANG REPRESENTATIVE OFFICE)
2-185, City Plaza, No. 206, Nanjing North
Street, He Ping District, Shenyang 110001
P.R. China
TEL: +86-24-2334 1178/89
FAX: +86-24-2334 2838

ANRITSU COMPANY LTD.
(WUHAN REPRESENTATIVE OFFICE)
A1803, ZhongShang Plaza
No. 9, Zhongnan Road
Wuchang, Wuhan 430071, P.R. China
TEL: +86-27-8771 3355
FAX: +86-27-8732 2773

ANRITSU COMPANY LTD.
(CHONGQING REPRESENTATIVE OFFICE)
No.14-10, Block A, Xinruididai, No.25,
Keyuan 1st Street, High-Tech Zone,
Chongqing, 400039, P.R. China
TEL: +86-23-8909-9918
FAX: +86-23-6383-0238

ANRITSU COMPANY LTD.
(NANJING REPRESENTATIVE OFFICE)
Room 2103, East Lilian Mansion,
No.29 Hubu Street, Nanjing, 210002,
P.R.China
TEL: +86-25-8689-5887
FAX: +86-25-4529132

• Cyprus
CHRIS RADIOVISION LTD.
23 Crete Street, T.T. 1061
P. O. Box 21989, 1515Nicosia, Cyprus
TEL: +357-2-766121
FAX: +357-2-765177

• Egypt
GIZA SYSTEMS ENGINEERING S.A.E
17 Teeba Street Mohandeseen P.O. Box
317 Dokki-Cairo 12311, Egypt
TEL: +20-2-3368095
FAX: +20-2-3385799

• Indonesia
PT. SUBUR SAKTI PUTERA
Graha Astri Aniela Angun, Jl. Tanah
Abang III/15, Jakarta 10160, Indonesia
TEL: +62-21-352-4828
FAX: +62-21-352-4831

• Israel
TECH-CENT LTD.
P. O. Box 43259 (Mailing Address),
Tel-Aviv 61430 Israel, Street Address:
Raul Valenberg 4 Ramat Haahayal, Tel-
Aviv 69710, Israel
TEL: +972-36-478563
FAX: +972-36-478334

• Korea
ANRITSU CORPORATION, LTD.
8F HyunJuk Building, 832-41

Yeoksam-Dong, Kangnam-Ku, Seoul 135-
080
Korea
TEL: +82-2-553-6603
FAX: +82-2-553-6604

ANRITSU CORPORATION, LTD.
Room 1503, Dong-A Venture Tower 538-8
BongMyung-Dong, Yusong-Gu
Daejeon, 305-301
Korea
TEL: +82-42- 828-7783
FAX: +82-2-42-828-7785

• Kuwait
TAREQ COMPANY
P.O. Box 20506 Safat, 13066 Safat,
Kuwait
TEL: +965-431-0615
FAX: +965-431-4085

• Malaysia
O'CONNOR'S ENGINEERING SDN BHD
3rd Floor Bangnan O'Connor, 13 Jalan
223, 46100 Petaling Jaya,
Selangor Darul Ehsan, Malaysia
TEL: +60-3-753-8400
FAX: +60-30-757-7871

• Morocco
SEDEL
24, 26, Bd, Resistance, Casablanca,
Morroco
TEL: +212-2-302444
FAX: +212-2-449311

• Nepal
BR INTERNATIONAL PVT. LTD.
P. O. Box 60, Tamrakar Comm. Bldg.,
Bhotabahal Kathmandu, Nepal
TEL: +977-1-224-706
FAX: +977-1-227-956

• New Zealand
NILSEN TECHNOLOGIES
(AUCKLAND OFFICE)
P. O. Box 9613, New market Unit 4,
Ambury Court, 1 Porters Ave, Eden
Terrace Auckland, New Zealand
TEL: +64-9-309-2464
FAX: +64-9-309-2968

NILSEN TECHNOLOGIES
(WELLINGTON OFFICE)
35 Ulric Street, Plimmerton Wellington,
New Zealand
TEL: +64-4-233-9116
FAX: +64-4-233-8366

• Oman
NATIONAL PROJECTS AND TECHNOLOGY COMPANY L.L.C
P. O. Box 97, Wadi Al Kabir, Postal Code
117, Sultanate of Oman
TEL: +968-793741
FAX: +968-796158

• **Pakistan**

AETCO

Zia Chambers, 25-Mcleod road, Lahore
54000, Pakistan
TEL: +92-42-7221716, 7311035
FAX: +92-42-7221456

**SUPERIOR ELECTRONICS
ASSOCIATED**

B-98 Block H, North Nasimabad,
Karachi-33, Pakistan
TEL: +92-21-613655

• **Philippines**

**SALRITSU INTERNATIONAL TRADING
CORPORATION**

5QB ODC International Plaza
Condominium, 219 Salcedo St., Legaspi
Village, Makati City 1229, Philippines
TEL: +632-816-2646, 893-8998
FAX: +632-815-0986

• **Puerto Rico**

CARIBBEAN DATA SYSTEM

636, San Patricio Ave. San Juan,
PR00920-4507, Puerto Rico
TEL: +1-787-774-6969
FAX: +1-787-774-6973

• **Qatar**

QATAR COMMUNICATIONS LTD.

P. O. Box 2481, Doha Qatar
TEL: +974-4-424347
FAX: +974-4-324777

• **Saudi Arabia**

A. RAJAB & A. SILSILAH & CO.

P. O. Box 203, Jeddah 21411, Saudi
Arabia
TEL: +966-2-6610006
FAX: +966-2-6610558

**ELECTRONIC EQUIPMENT
MARKETING CO.**

P. O. Box 3750, Riyadh, 11481,
Saudi Arabia
TEL: +966-3-887-0218
FAX: +966-3-887-0268

• **Singapore**

ANRITSU PTE. LTD.

10, Hoe Chiang Road #07-01/02, Keppel
Towers, Singapore 089315
TEL: +65-6282-2400
FAX: +65-6282-2533

• **South Africa**

ETECSA (PTY) LTD.

12 Surrey Square Office Park, 330 Surrey
Avenue, Ferndale, 2194 Randburg,
South Africa (P. O. Box 4231 Randburg,
2125 South Africa)
TEL: +27-11-787-7200
FAX: +27-11-787-0446

• **Sri Lanka**

INFOTECHS LIMITED

441, Alwitigala Mawatha, Colombo,
Sri Lanka
TEL: +94-1-598237
FAX: +94-1-598112

• **Taiwan**

**ANRITSU COMPANY, INC.
(TAIPEI OFFICE)**

7F, No. 316, Sec. 1, NeiHu Rd.,
Taipei 114, Taiwan
TEL: +886-2-8751-1816
FAX: +886-2-8751-1817

**ANRITSU COMPANY, INC.
(HSINCHU OFFICE)**

No. 21, Lane 23, Guandung Road,
Hsinchu 300, Taiwan
TEL: +886-3-563-6601, 6602, 6603
FAX: +886-3-564-5819

ANRITSU COMPANY, INC.

7F-3, No.32, Lane 185, Sec. 2,
Chung Hua E. Rd., Tainan 701,
Taiwan
TEL: +886-6-290-7735
TEL: +886-6-290-3260

• **Thailand**

**JASMINE TELECOM SYSTEMS CO.,
LTD.**

200 Moo 4, 9th Floor, Chaengwatana
Road, Tambon Pakkret, Amphoe Pakkret,
Nonthaburi 11120, Thailand
TEL: +66-2-502-3240, 3000
FAX: +66-2-962-2521

• **United Arab Emirates**

**UTMOST ELECTRONICS TRADING
L.L.C.**

(ABU DHABI BRANCH)
P. O. Box: 41175, Abu Dhabi,
United Arab Emirates
TEL: +971-2-6458909
FAX: +971-2-6458907

• **Vietnam**

**SYSTEM & TECHNOLOGIES VETNAM
LTD.**

Unit # B236, Binh Minh Hotel 27 Ly Thai
To Str Hanoi, Vietnam
TEL: +84-48.264.728
FAX: +84-49.344.111

• **Zimbabwe**

MARTWELL ELECTRONICS (PVT) LTD.

P.O. Box CH 857 Chisipite Harare,
Zimbabwe
TEL: +263-4-494928
FAX: +263-4-494927



• **Japan**

ANRITSU CORPORATION

1800 Onna, Atsugi-shi, Kanagawa,
243-8555, Japan
TEL: +81-46-223-1111
FAX: +81-46-296-1264

Free Manuals Download Website

<http://myh66.com>

<http://usermanuals.us>

<http://www.somanuals.com>

<http://www.4manuals.cc>

<http://www.manual-lib.com>

<http://www.404manual.com>

<http://www.luxmanual.com>

<http://aubethermostatmanual.com>

Golf course search by state

<http://golfingnear.com>

Email search by domain

<http://emailbydomain.com>

Auto manuals search

<http://auto.somanuals.com>

TV manuals search

<http://tv.somanuals.com>