



XEQ

7-BAND EQUALIZER WITH DIRECT SUB INPUT

IDX

3-WAY CROSSOVER WITH SUB SONIC FILTER

MANUAL AND USER GUIDE



XEQ

- Front panel Sub output level control
- Variable Sub woofer Crossover
- Variable Sub woofer Crossover
- 4-Layer PC Board with SMT Devices
- Direct "Sub Input"
- 8 Volt RMS Output
- Input Clip Indicator for Easy Gain Setting

IDX

- Fully Variable Band Pass Crossover
- Sub Sonic Filter
- Variable Sub Phase Shift
- 4-Layer PC Board with SMT Devices
- Independent Front and Rear Inputs
- 8 Volt RMS Output
- Output Clip Indicator for Easy Gain Setting

LIMITED WARRANTY

Before shipping this product back for service call for a Return Authorization number. This number must be clearly marked on the outside of the box.

Terms & Conditions: ARC Audio warrants the unit to be free of any material defects or defects in workmanship for a period of one year and will repair or replace this unit or any part thereof only if it proves to be defective as a result of normal use. In order to receive warranty service on this product, the owner must promptly register by filling in and mailing the Warranty Registration Card.

Our obligation under this warranty is limited to repairing only the defective components of the unit thereof when it is returned, shipping prepaid, to ARC Audio.

This warranty is to be considered void if the unit has been tampered with, connected contrary to the installation instructions in the owner's manual, altered, damaged by improper input voltages or polarity, defaced, or treated in a negligent manner.

All returns must be sent freight prepaid, along with \$10.00 to cover return shipping and handling.

Out of warranty service is available after the warranty expires. Cost of repair is based on current repair labor rates, plus the cost of shipping and handling. When returning for repair, pack the unit securely and send prepaid and insured to the address below. ARC Audio is not responsible for damage incurred during shipping.

For warranty and non-warranty repairs, send to:

**ARC Audio
4719 Green Leaf Cr. #4
Modesto CA, 95356
Tel. 209.543.8706**



XEQ

Table of Contents

Introduction	1
Features	2
Advanced Features	2
Installation Information	3
Connections and Controls	4
Detailed Review of Controls	5
System Examples	
2-Way with Direct Sub Input	6
2-Way with Fading Front and Rear	7
Specifications	8
IDX Manual	9

Introduction

Welcome to the Arc Audio family of performance signal processors. A blend of Arc Audio's lengthy experience in performance car audio design combined with our highly skilled engineering staff. You are now the proud owner of the **IDX** or **XEQ**. A unique combination of the highest quality analog components and precision engineering. Whether you are a competitor or simply enjoy faithfully reproduced music, you will definitely appreciate how these products make your system sound. These components aren't the easiest to understand and use. They require a good understanding of audio and the terms and language used to describe it. You don't have to be a genius but a bit of experience and common sense will go a long way. This manual is written in 2 parts **IDX** and **XEQ**. Each of these units can be used separately or together to become the Control Center. Before you begin read this manual cover to cover (does anyone ever really read the manual?). Carefully design your system and decide on your basic crossover points. This will give you a good starting point and a reference to return to when you begin final tuning. If at any point you begin to feel overwhelmed, return to your local Arc Audio dealer and let the trained professionals install or tune it for you.

XEQ

Features:

1. 7 Band Equalizer
2. Variable Sub woofer Crossover
3. Front panel sub woofer output level control
4. 8 Volt RMS Output
5. Direct "Sub Input" for Head units with Sub woofer Output
6. Sub EQ Bypass
7. Input Clip Indicator for Easy Gain Setting
8. 4-Layer PC Board with SMT Technology
9. Front and Rear Fader
10. Quiet Mute for Noise Free Turn-on's

Advanced Features

Direct Sub Input

The **XEQ** is equipped with a "**Direct Sub Input**" That allows you to take full advantage of modern head units with Special features like, Sub Output, Time Alignment, Bass Restoration, And Sub Crossover. You paid for these features. We feel you should be able to use them and still enjoy the benefits of a high quality in-dash EQ. By connecting your head unit Sub out to the "**Direct Input**" All these features still work. All the signal from your Sub out is directed to the Master Volume then to the Sub Level and Sub Crossover. With the **XEQ** you get the best of both worlds. Advanced System Controls and the full benefit of a High quality 7 Band EQ.

Installation Information

1. The XEQ needs to be installed in the signal path between your source unit and your external amplifier(s).
2. Physically mount the XEQ near the drivers listening position. Make sure the EQ is kept clean, cool, and dry. Don't mount it under a cup holder or in a storage box where it will be covered with the stuff that always seems to collect in our cars.
3. Hook up +12 volt power, ground, and remote turn-on. Make sure the ground is perfectly clean and tight. Remove all the paint and under coat before you screw it down. Don't trust the stock ground. Make a new one.
4. Connect the front output of your head unit to the front input of the XEQ.
5. Connect the Sub out to the "Direct Sub Input". This is optional. Make sure the switches on top are configured correctly.
6. Don't fix the EQ permanently into place until your gains have been set.
7. Adjust the "Input Level" control on your XEQ to match the source unit's output. With the head unit volume at about 75% of max, move the gain switch from 0dB to +6 dB. Look at the input clip light on the front of the EQ. It should NOT be on. It may flash occasionally. If it doesn't flash, move the gains to +12dB. Unless you have a very low output head unit the clip light will surely be flashing now. If it is move back to +6dB or +0dB.
8. Now the fun begins. With the EQ still out, begin adjusting the sub crossover. Try to find a good neutral. You can always change the level later.
9. Start tweaking. It's amazing how much a tiny adjustment to your EQ frequency can change your system.
10. Enjoy the results

The Connections and Controls

1. Front Output
2. Rear Output
3. Input
4. Sub "Direct Input"
5. Sub Output
6. Power Connector
7. Input Gain
8. Sub Input Gain
9. Sub Crossover Switch
10. Sub "Direct Input" Switch
11. Sub EQ Bypass
12. Sub Frequency Control
13. Master Volume
14. Clip Indicator
15. EQ Frequency Controls
16. Fader
17. Sub Volume

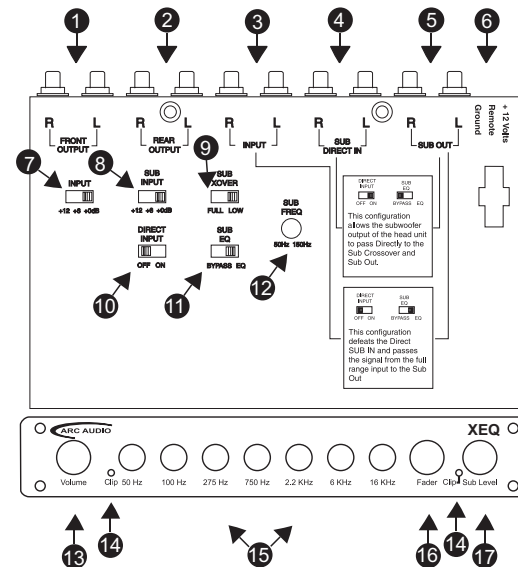

1. **Front Output:** Simply connect to the amplifier driving the front speakers. This is a full range output so if you plan to run it hard you should use a crossover at this point.
2. **Rear Output:** Just like it sounds, this is connected to the rear amp.
3. **Input:** Main Input should be a full range signal from the head unit. If you are using the Sub Direct Input the signal could be crossover but the EQ will function better if you feed it a full range signal.
4. **Sub "Direct Input":** This is where things get a little tricky. If your deck has a sub woofer output with any kind of advanced feature you may wish to use the Sub Direct Input. This input bypasses the EQ section and feeds signal to the Master Volume and to the Sub Out. In this way all you features still work
5. **Sub Output:** Connect to your Sub woofer amp or amps.
6. **Power Connector:** 12 Volt +, Remote and Ground. We recommend using a dedicated 12 Volt+ from the battery and a fresh ground. Remember this EQ has an 8-volt output. It takes a good amount of current to run.
7. **Input Gain:** Most modern head units have between 4 and 8-volt outputs. With this input level the XEQ gains should be left at +0dB. Only use the +6dB and +12dB in extreme conditions were you just can't get enough gain from the head unit.
8. **Sub Input Gain:** I know it's tempting to add a bit more gain to the Sub input but this isn't the place to do it. In most cases it should match the input gain
9. **Sub Crossover Switch:** The XEQ has a 12dB Sub woofer crossover. This feature can be bypassed by setting the switch to "Full". Warning: The Sub Out will now be Full Range.
10. **Sub "Direct Input" Switch:** Bypasses the EQ and routes the sub signal directly to the "Sub Out" allowing the use of the advanced features in your head unit.
11. **Sub EQ Bypass:** With this switch it is possible to bypass the EQ for the sub out. This could be helpful for tuning your mid bass woofers without making any changes to the sub woofers. This switch must be in "Bypass" mode if you are using the "Sub Direct In".
12. **Sub Frequency Control:** Be sure to make your final adjustments to the Sub crossover before you mount the unit into the dash of your car. You will need to complete your tuning first.
13. **Master Volume:** Controls all Output including the "Sub Out". It is very handy to have one volume under your thumb for "Fast" and easy control.
14. **Clip Indicator:** Use these as a guide. If the clip lights are flashing you're in the 'Danger Zone" If the system can't get loud without the Clip lights flashing, reevaluate your gain setting.
15. **EQ Frequency Controls:** If you know what an EQ does, you most likely know what these do. We've crammed 7 bands into the XEQ, for ultimate control at your fingertips.
16. **Fader:** Full front/rear control to keep the people in the back seat happy.
17. **Sub Volume:** Or Sub Out level, gives you total control of the Sub Gain at any time.

2-WAY With DIRECT SUB INPUT

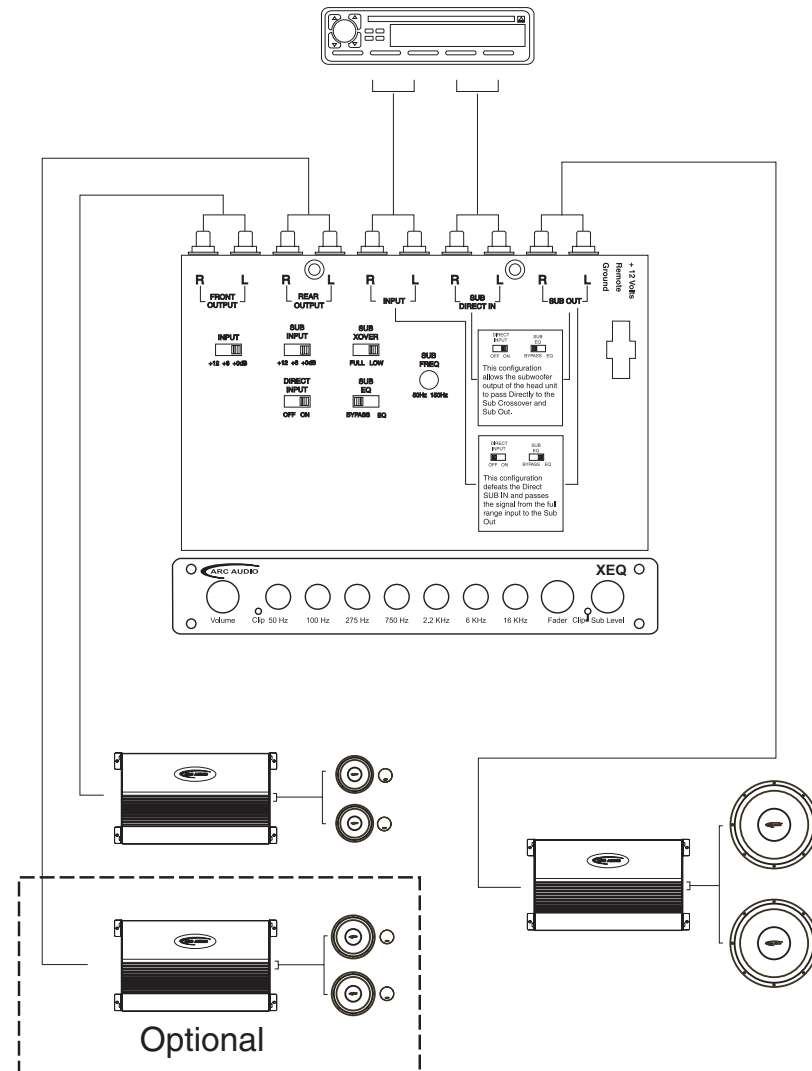

2-WAY With FADING FRONT and REAR

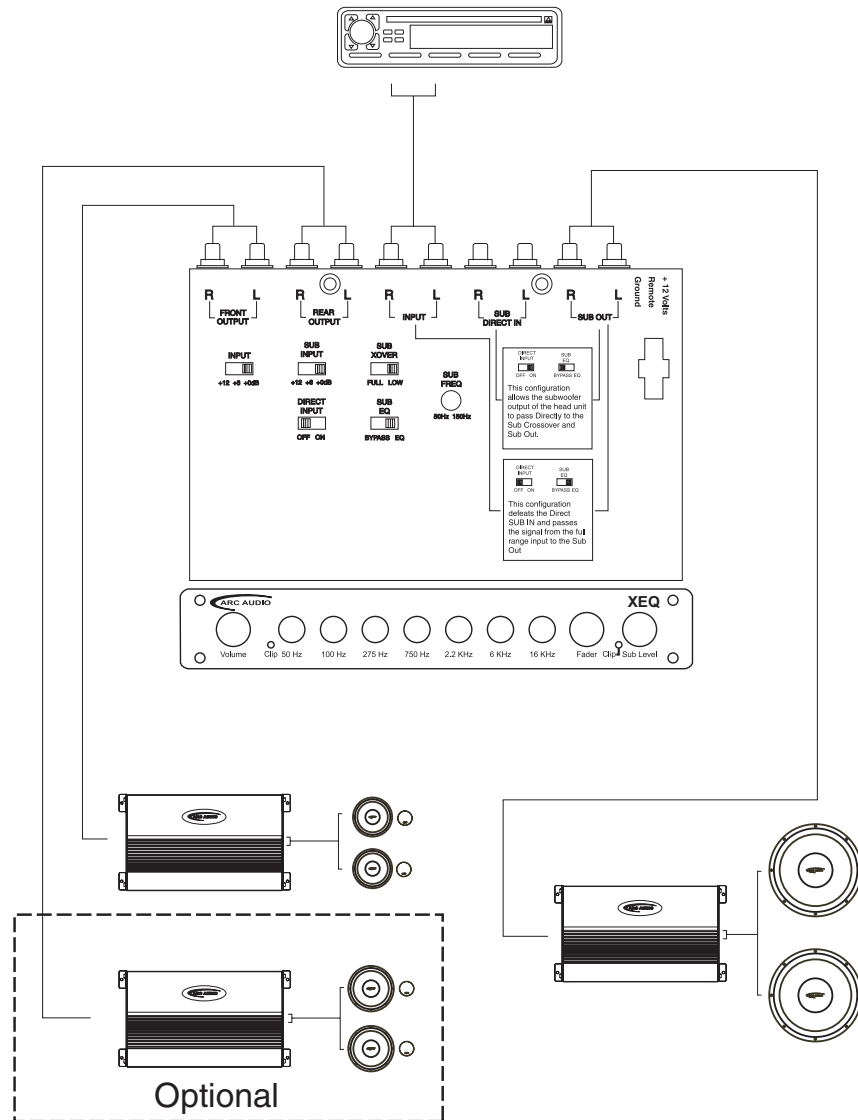

XEQ SPECIFICATIONS

Signal to Noise Ratio (A-Weighted)	>100dB
THD @ 8.0V Output	0.005%
Channel Separation	>75dB
EQ Frequency Range @ 50Hz	+/- 12dB, Q=1.38
100Hz	+/- 12dB, Q=1.20
275Hz	+/- 12dB, Q=1.25
770Hz	+/- 12dB, Q=1.18
2.2KHZ	+/- 12dB, Q=1.08
6.0KHz	+/- 12dB, Q=1.10
16.8KHZ	+/- 12dB, Q=0.98
Sub Woofer Crossover	45Hz-150Hz 12dB/Octave
Input Impedance	15K Ohms
RMS Output @ 1KHz	9.0 Volts
Frequency Response	20Hz-30KHz

IDX

Table of Contents

Introduction	9
Features	10
Installation Information	11
Connections and Controls	12
Detailed Review of Controls	13-14
System Examples	
2-Way Fading Front and Rear	15
3-Way With Active Filtering for Mids and Tweeters	16
3-Way With Active Filtering for Mid Bass and Component Set	17
Specifications	18

Introduction

Welcome to the Arc Audio family of performance signal processors. A blend of Arc Audio's lengthy experience in performance car audio design combined with our highly skilled engineering staff. You are now the proud owner of the **IDX** or **XEQ**. A unique combination of the highest quality analog components and precision engineering. Whether you are a competitor or simply enjoy faithfully reproduced music, you will definitely appreciate how these products make your system sound. These components aren't the easiest to understand and use. It requires a good understanding of audio and the terms and language used to describe it. You don't have to be a genius but a bit of experience and common sense will go a long way. This manual is written in 2 parts **IDX** and **XEQ**. Each of these units can be used separately or together to become the Control Center. Before you begin read this manual cover to cover (does anyone ever really read the manual?). Carefully design your system and decide on your basic crossover points. This will give you a good starting point and a reference to return to when you begin final tuning. If at any point you begin to feel overwhelmed, return to your local Arc Audio dealer and let the trained professionals install or tune it for you.

IDX

Features:

1. 3-WAY Electronic Crossover
2. ½ DIN Mounting Option
3. Fully Variable Band Pass Crossover
4. Sub Sonic Filter
5. Variable Sub Phase Shift.
6. Independent Front and Rear Inputs
7. 8 Volt RMS Output
8. Output Clip Indicator for Easy Gain Setting
9. 4-Layer PC Board with SMT Technology
10. Quiet Mute for Noise Free Turn-on's

Advanced Design Features

The **IDX** is designed to take full advantage the front listening positions by making it easier to make adjustment without constantly jumping in and out of the car. Clearly this method does not require the sound memory typically needed to tune a system. You hear any change you make while your hand is still on the control. If it works you leave it. If it doesn't you can change it back immediately. This reduces the time needed to "Get into the Ballpark" and get down to some serious fine-tuning.

Installation Information

1. The **IDX** needs to be installed in the signal path between your source unit and your external amplifier (s).
2. Because of its small size the **IDX** can be mounted almost anywhere. The chassis is designed to fit a 1/2 DIN opening. however it will work just as well under a seat or in the trunk. For easiest tuning mount it near the drivers listening position. Make sure the Crossover is kept clean, cool, and dry. Don't mount it under a cup holder or in a storage box were it will be covered with the stuff that always seems to collect in our cars.
3. . Hook up +12 volt power, ground, and remote turn-on. Make sure the ground is perfectly clean and tight. Remove all the paint and under coat before you screw it down. Don't trust the stock ground. Make a new one.
4. Connect the front output of you head unit to the front input of the **IDX**.
5. You may choose to connect the rear output of the head unit to the rear input of the crossover. This is optional. Make sure the switches on top are configured correctly.
6. Connect your outputs to your amplifier (s) It is recommended that you mark your RCA cables at both ends. This will avoid confusion and reduce the trouble shooting later on.
7. Don't fix the **IDX** permanently into place until you have configured all your crossovers.
8. Now the fun begins. Start tweaking. It's amazing how much a tiny adjustment to your crossover frequency can change your system.

This is a very abbreviated description of a typical install. Every install is a bit different. Take your time and read your instructions (you know you should). If you begin to feel you're getting in over you head, Pack it back up and take it to your nearest ARC Audio dealer for professional installation.

Alternate Mounting Locations

Modern vehicles can be a real challenge to the creativity of your installer. The compact design and side mounted controls of the **IDX** open up many more options for you.

Under seat installation and tuning has always been a nightmare with traditional crossover designs but the **IDX** can be easily tuned without removing the seat.

Likewise, many compact cars have small bins in the trunk that seem made for the **IDX**.

With a little creativity the **IDX** can do almost anywhere. When you stop and think about it, it's really more versatile the a traditional design.

The Connections and Controls

- | | |
|-------------------------------|-------------------------------|
| 1. Front Input | 14. Front X-Over Gain |
| 2. Rear Input | 15. Front Frequency Control |
| 3. Front Output | 16. Clip and Power Lights |
| 4. Rear Output | 17. Rear High Pass X10 Switch |
| 5. Sub Output | 18. Rear High Pass Control |
| 6. Power Connector | 19. Rear X-Over Gain |
| 7. Input Mode Switch | 20. Rear Low Pass Control |
| 8. Front Crossover Switch | 21. Rear Low Pass X10 Switch |
| 9. Rear Hi Pass X-over Switch | 22. Sub Sonic Filter Control |
| 10. Rear Low Pass Switch | 23. Sub X-Over Gain |
| 11. Sub Sonic Filter Switch | 24. Sub Frequency Control |
| 12. Sub X-Over Slope Switch | 25. Phase Shift Control |
| 13. Front X-Over X10 Switch | |

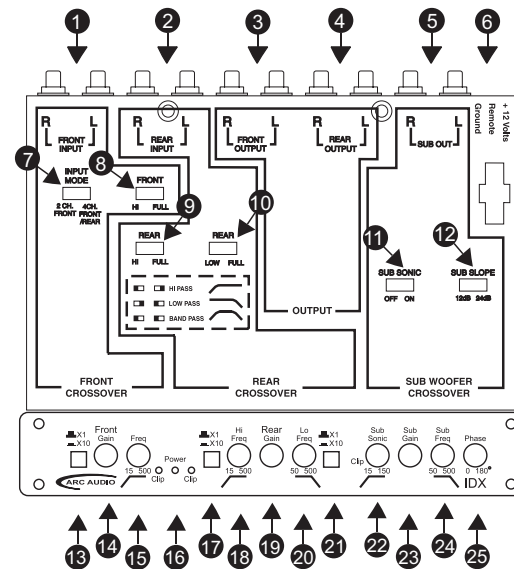

- 1. Front Input:** This is the default input. If you are using one input (2 CH.) connect your RCAs here.
- 2. Rear Input:** Use the rear inputs for 4-channel operation. In this configuration you can have faded front and rear front your hear unit.
- 3. Front Output:** Front output in name only. If you're using the IDX in 3-Way this will be your High Pass x-over. This is a High Pass only crossover.
- 4. Rear Output:** The rear output can be set as High Pass, Low Pass or Band Pass. To use the Band Pass mode you will need to set both High Pass and Low Pass switches on top of the unit. With both turned on the output will switch to Band Pass. *Note: For this to work the High Pass will have to be set at a lower frequency than the Low Pass. The Low Pass will filter out the high frequencies above the Band Pass. The High Pass will filter out the low frequencies below the Band Pass. Confusing? Look at the little lines printed below the controls. This will help give you a good mental picture of what's happening.*
- 5. Sub Output:** The Sub Output gets its signal by combining the front and rear inputs. If you're using the 2 Channel input option, your entire signal will come from the Front Channel input.
- 6. Power Connector:** 12 Volt +, Remote and Ground. We recommend using a dedicated 12 Volt+ from the battery and a fresh ground. Remember this Crossover has an 8-volt output. It takes a good amount of current to run.
- 7. Input Mode Switch:** Select between 2 Channel or 4 Channel input. When in 2 Channel Mode the IDX will turn off the Rear Channel input and only except input from the Front input to drive all the output channels.
- 8. Front Crossover Switch:** High Pass or Full Range. Turns the crossover on or off.
- 9. Rear Hi Pass Switch:** Turns on the rear High Pass. When you use this with the Rear Low Pass the output becomes a Band Pass.
- 10. Rear Low Pass Switch:** Same as above.
- 11. Sub Sonic Filter Switch:** The IDX is equipped with a variable Sub Sonic Filter.
- 12. Sub X-Over Slope Switch:** 12 or 24dB
- 13. Front X-Over X10 Switch:** It is impossible to accurately adjust a crossover with a frequency range from 15Hz to 5000Hz. Even the tiniest turn would make a huge change. For this reason we have added a X10 or 10 times switch. When this switch is activated the frequency will be 10 Times that marked on the face. 50Hz becomes 500Hz. 500Hz becomes 5000Hz.

14. Front X-Over Gain: Each crossover has its own gain. This will make up front tuning much easier. You will only need to make basic adjustments to your amp gains.

15. Front Frequency Control: 15Hz to 500Hz (150Hz to 5000Hz in X10 mode). This should cover most speaker combinations.

16. Clip and Power Lights: To ease tuning the clip lights will begin to flash just before the output clips. This will help insure the amps receive a clean unclipped, undistorted signal.

17. Rear High Pass X10 Switch: Same as the Front X10 Switch.

18. Rear High Pass Control: Controls the High Pass Frequency. It is also use to remove the low frequencies when in Band Pass.

19. Rear X-Over Gain: Same as the front Gain.

20. Rear Low Pass Control: Controls the Low Pass Frequency. It is also use to remove the high frequencies when in Band Pass.

21. Rear Low Pass X10 Switch: Same as Rear High Pass X10 but for the Low Pass control.

22. Sub Sonic Filter Control: Removes the lowest frequencies from the bass signal. These frequencies are the hardest to reproduce by an amp. Rarely can they even be heard by the human ear. In some cases, when you use a ported box, the woofers can be damaged by frequencies below the port tuning frequency. These are just 2 reasons to use a Sub Sonic Filter.

23. Sub X-Over Gain: This is the one control most likely to be turned up all the way. Don't worry, the clip light will tell you when you are getting into trouble.

24. Sub Frequency Control: Unlike the other frequency controls, this one does not have a X10 switch.

25. Phase Shift Control: "Timing is everything". I a typical install the mid bass speakers are in the front of the car between 3 to 5 feet from you ear. The sub woofer is all the way in the back, 9 to 12 feet way. Sometimes more. The Phase Shift can be used to compensate for this difference in distance by causing the sound from both speakers to arrive at your ear at the same time. This can really help bring the bass up front making the system sound more like a live performance.

2-WAY FADING FRONT AND REAR

NOTE: THE CONTROL POSITIONS SHOWN ARE ONLY ONE SUGGESTED CONFIGURATION. YOUR SYSTEM MAY REQUIRE DEFERENT SETTINGS.

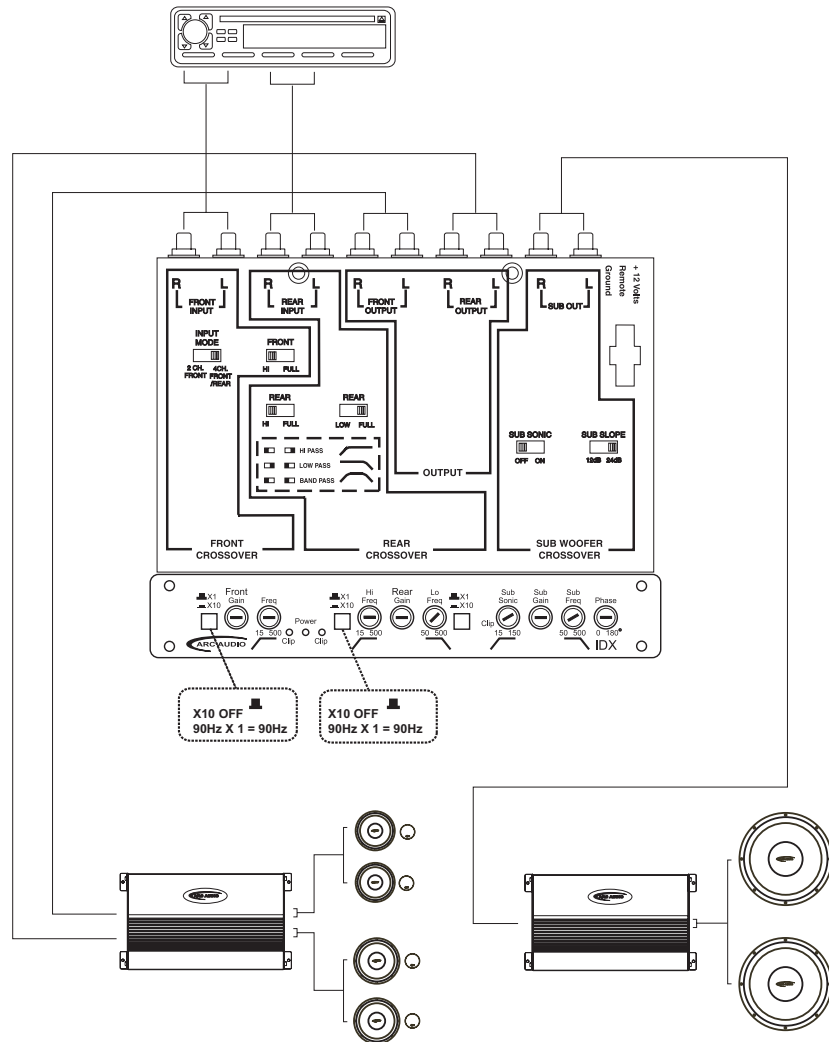

3-WAY WITH ACTIVE FILTERING FOR MIDS AND TWEETERS

NOTE: THE CONTROL POSITIONS SHOWN ARE ONLY ONE SUGGESTED CONFIGURATION. YOUR SYSTEM MAY REQUIRE DEFERENT SETTINGS.

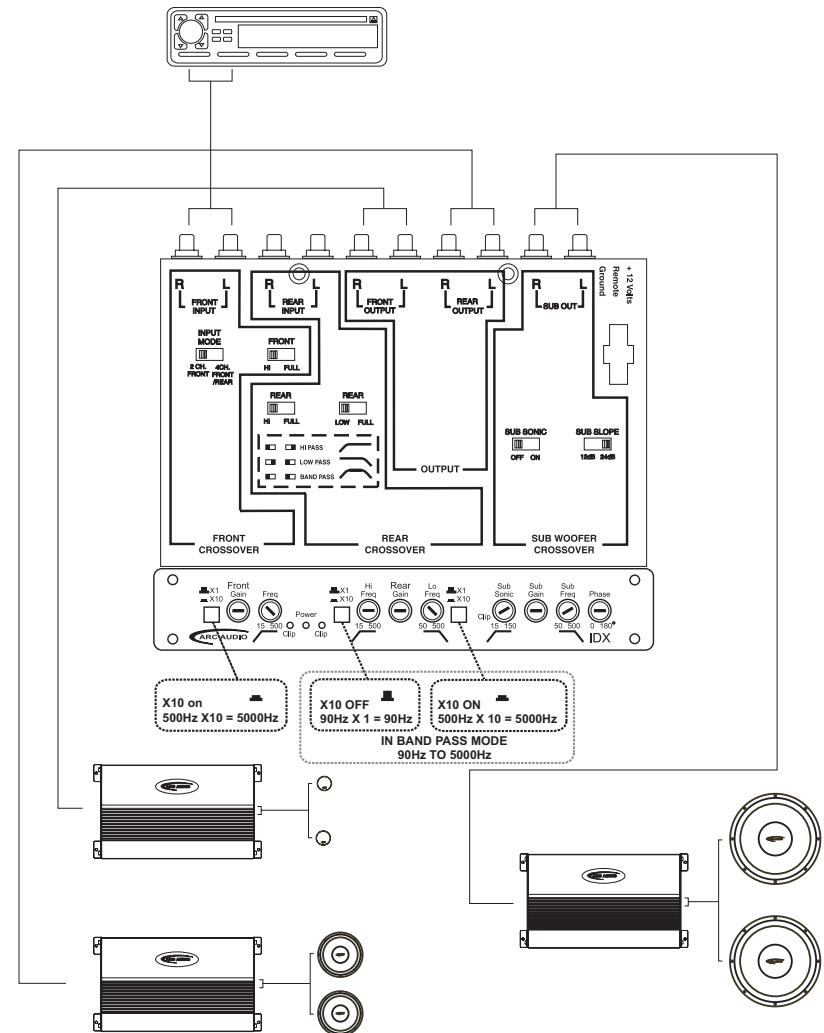

3-WAY WITH ACTIVE FILTERING FOR MID-BASS AND COMPONENT SET

NOTE: THE CONTROL POSITIONS SHOWN ARE ONLY ONE SUGGESTED CONFIGURATION. YOUR SYSTEM MAY REQUIRE DEFERENT SETTINGS.

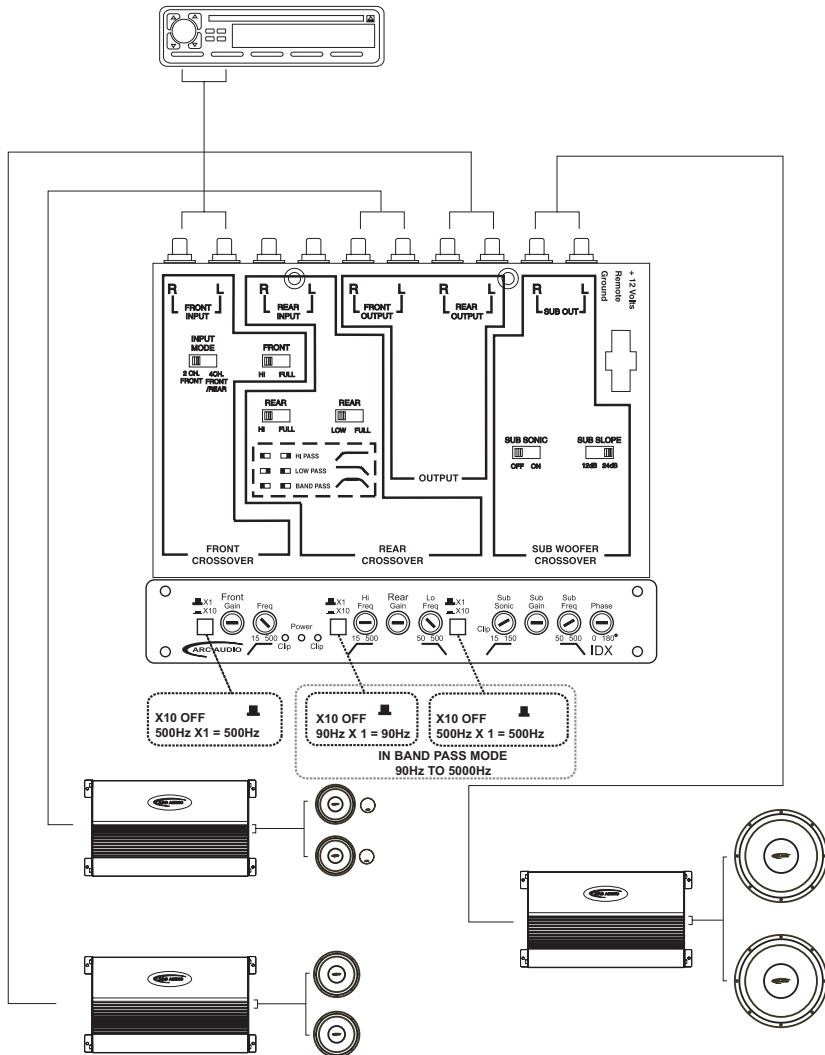

IDX SPECIFICATIONS

Signal to Noise Ratio (A-Weighted)	>100dB
THD @ 9.0V Output	0.005%
Channel Separation	>75dB
Sub Sonic Filter (12dB/Octave)	15Hz-150Hz
Sub Woofer Crossover	50Hz-500Hz 12dB/24dB(MONO)
Front High Pass Crossover (12dB/Octave)	15Hz-500Hz (X10=150Hz-5KHz)
Rear High Pass Crossover (12dB/Octave)	15Hz-500Hz (X10=150Hz-5KHz)
Rear Low Pass Crossover (12dB/Octave)	50Hz-500Hz (X10=500Hz-5KHz)
Input Impedance	15K Ohms
RMS Output @ 1KHz	9.0 Volts
Frequency Response	20Hz-30KHz

Free Manuals Download Website

<http://myh66.com>

<http://usermanuals.us>

<http://www.somanuals.com>

<http://www.4manuals.cc>

<http://www.manual-lib.com>

<http://www.404manual.com>

<http://www.luxmanual.com>

<http://aubethermostatmanual.com>

Golf course search by state

<http://golfingnear.com>

Email search by domain

<http://emailbydomain.com>

Auto manuals search

<http://auto.somanuals.com>

TV manuals search

<http://tv.somanuals.com>