

AQUAPRO[®]

Directional Feeder System

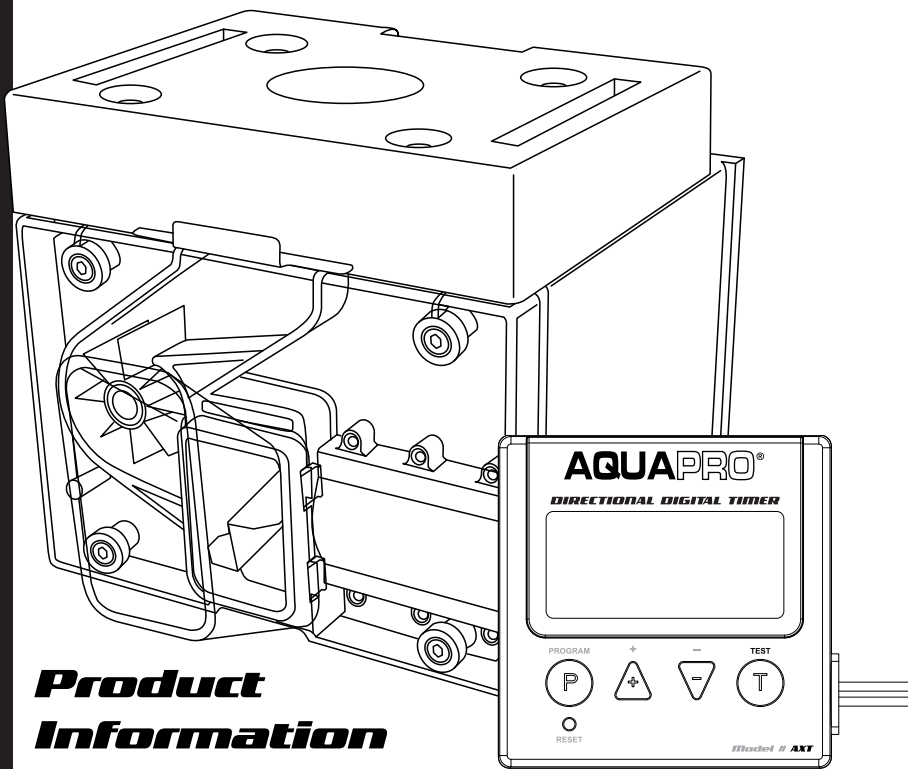

Product Information Guide

Model # ATX

INCLUDED PARTS

- 1) Directional Power Control Unit (1)
- 2) Mounting Bracket (attached) (1)
- 3) Clear Disbursement Chute (1)
- 4) Directional Digital Timer Unit (1)
- 5) Top Mounting Plates (2)
- 6) 8MM x 3/4" bolt (4)
- 7) 8MM x 3/4" Sheet Metal Screw (4)
- 8) 8MM x 3/4" Self Tapping Screws (4)

REQUIRED TOOLS

- 1) 8MM Nut driver
- 2) Pliers
- 3) Cordless or Electric Drill (if necessary)
- 4) 1/8" drill bit (if necessary)
- 5) 1/4" drill bit (if necessary)
- 6) Pen/Marker (if necessary)
- 7) 1 1/2"-2" Hole Saw (if necessary)

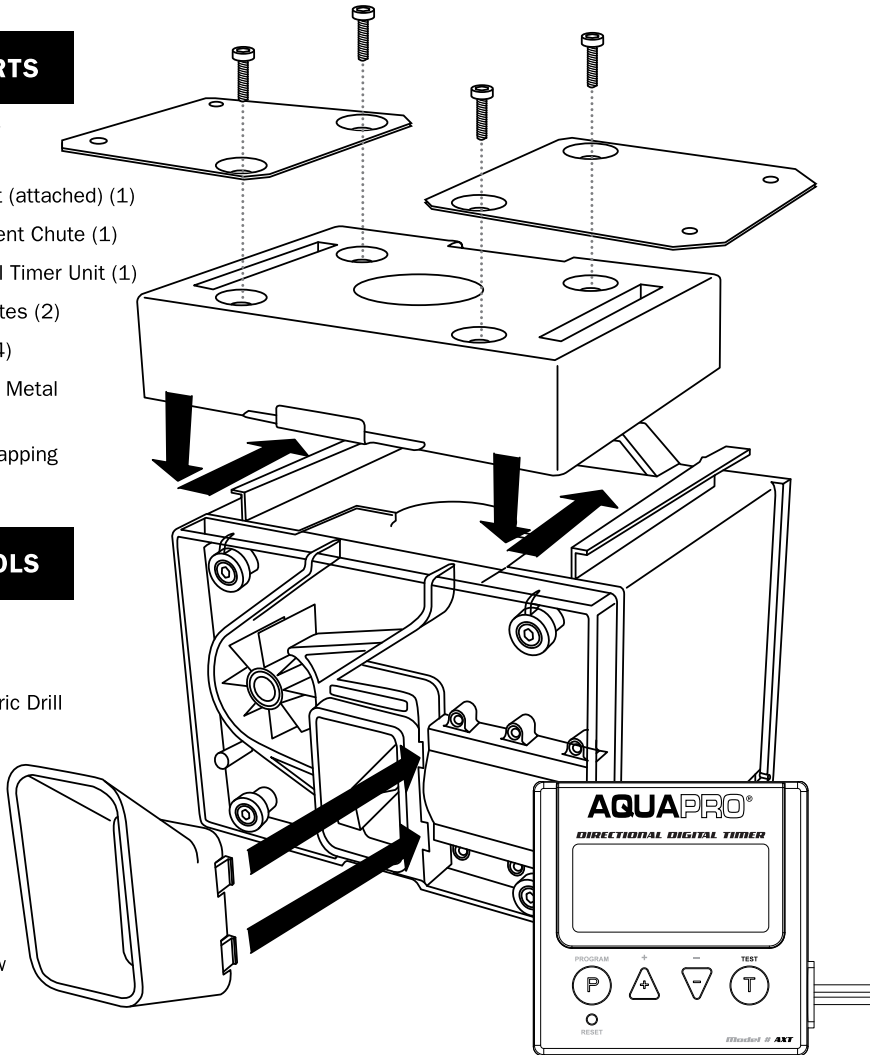

ASSEMBLY INSTRUCTIONS

1 Verify the contents of the package against the included parts list. If you are missing any parts from the list, please contact BA Products immediately at the toll-free number provided.

2 Remove contents of directional power control unit box.

3 Turn the box so that the disbursement opening is facing away from you. (clear side) (Illustration A)

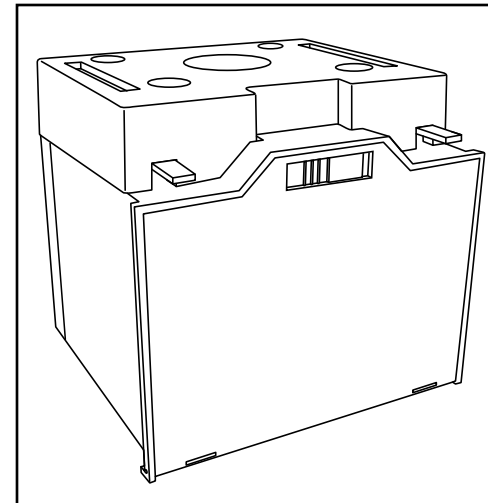

(Illustration A)

IF MOUNTING ON A AQUA PRO POLY BARREL.

4 Locate and align one of the Top Mounting plates with the mounting holes in the top of the unit.

5 Locate and align one of the Top Mounting plates with the mounting holes in the top of the unit. (Illustration B)

6 Repeat step 5 for the other side of box. (Illustration B)

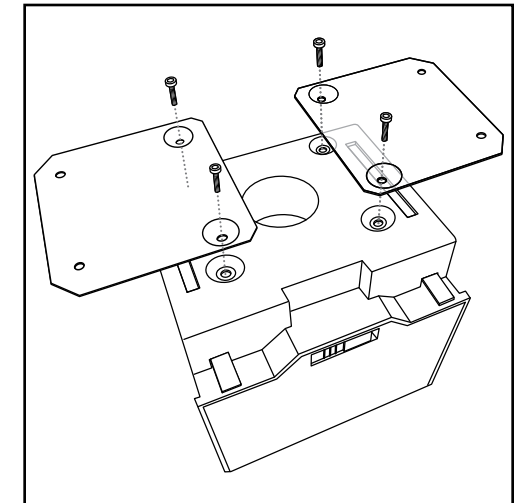

(Illustration B)

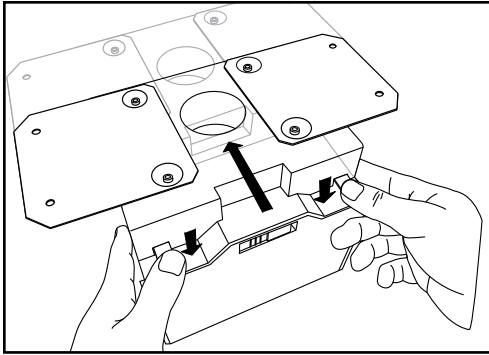

(Illustration C)

7 Detach the mounting bracket from the unit by depressing the two retainer clips and sliding the mounting bracket away from you. (Illustration C)

8 Now position the mounting bracket over the hole in the container making sure the hole is the same size as the hole in the top of the unit. (Illustration D)

9 Install the four #8 x 3/4" sheet metal screws into each of the four mounting holes on the poly barrel and tighten. (Illustration D)

10 Proceed directly to step 16.

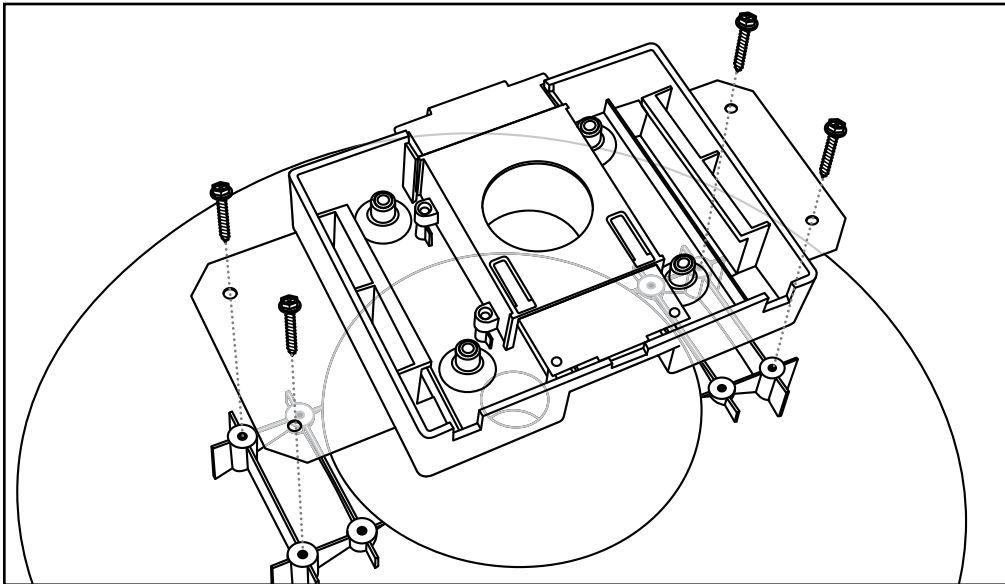

(Illustration D)

IF NOT MOUNTING TO A AQUA PRO POLY BARREL.

11 Detach the mounting bracket from the unit by depressing the two retainer clips and sliding the mounting bracket away from you. (Illustration E)

12 Now position the mounting bracket over the hole in the container making sure the hole is 1 1/2"-2" wide.

13 Mark the four mounting holes to be drilled. Make sure that the metal shutoff lever is facing toward the front of the feeder in the direction you wish for the feed to be disbursed. (Illustration F)

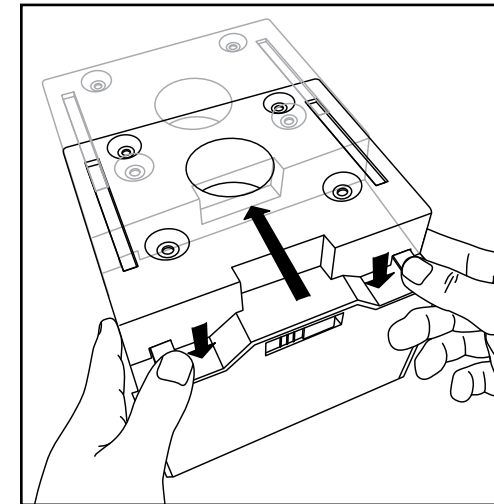

(Illustration E)

14 Drill the four holes with a 1/4" drill bit. (Illustration G)

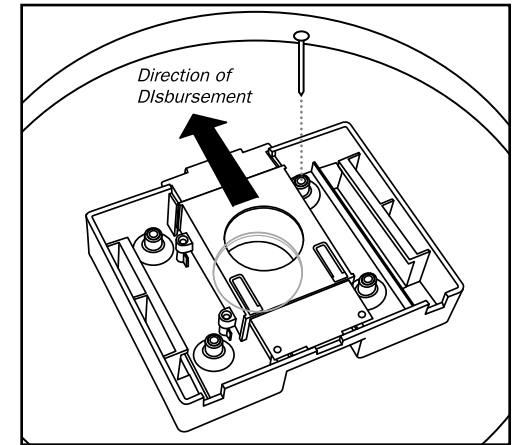

(Illustration F)

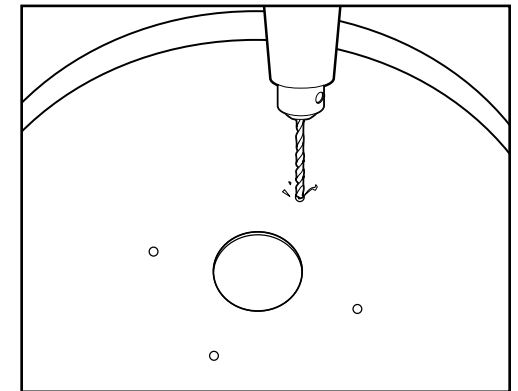

(Illustration G)

15 Install the 8MM x 3/4" bolts in the holes and into the mounting bracket nuts in the mounting bracket and tighten. (Illustration H)

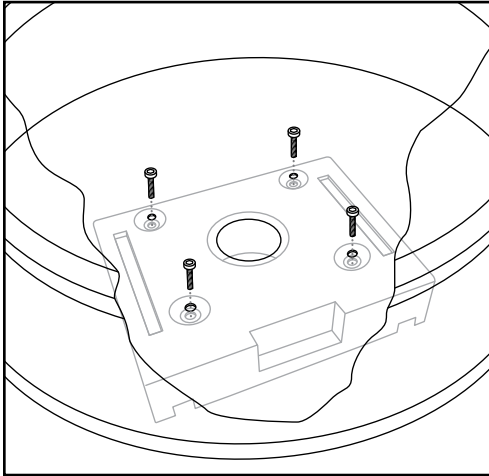

(Illustration H)

***Note: make sure that there are no obstructions in the feed disbursement area as this will effect the performance of the unit. Examples: feeder legs, solar panel, etc.**

16 Once the mounting bracket is installed reattach the directional power control unit to the mounting bracket by simply aligning the slots in the top of the unit with the retainer clips on the mounting bracket and sliding until you hear, or feel it, click into place. (Illustration I)

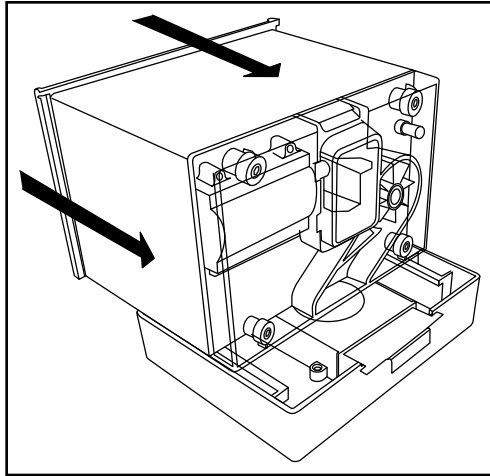

(Illustration I)

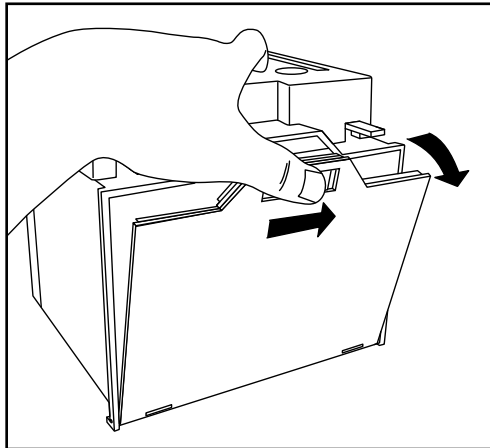

(Illustration J)

17 Next, open the directional power control unit and locate the timer. (Illustration J)

18 Locate the motor wire harness that has four wires on it and plug it into the receptacle located on the inside right hand side of the directional power control unit box and gently push until in place. (Illustration K)

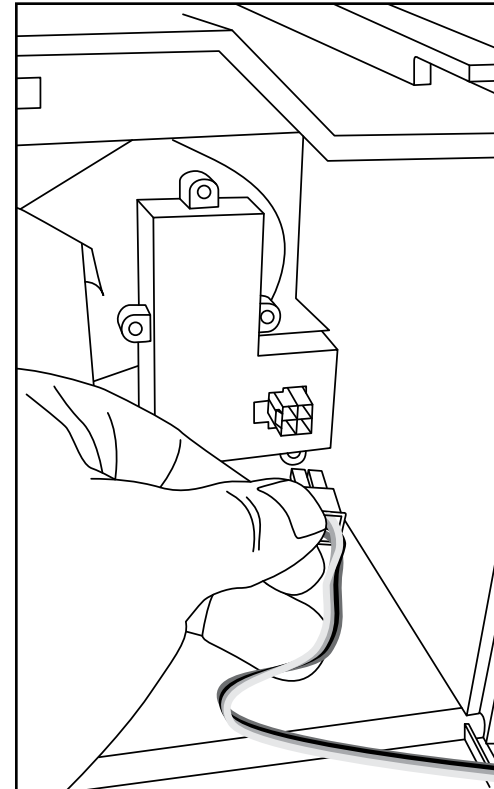

(Illustration K)

19 Once step 18 is complete, find the remaining two motorwires and attach the Positive wire from the timer (white) to the Positive wire from the motor. (white) (Illustration L)

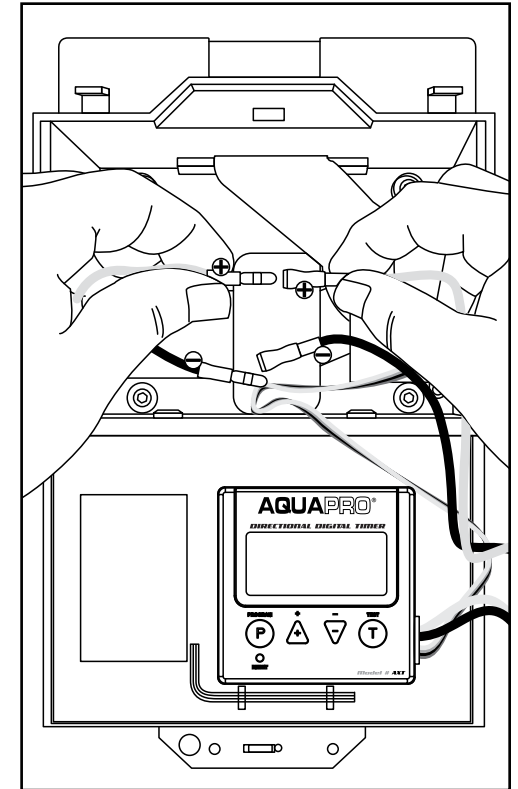

(Illustration L)

20 Then, locate and attach the Negative wire from the timer (blue) to the Negative wire from the motor. (blue) Insure a good tight fit. (Illustration M)

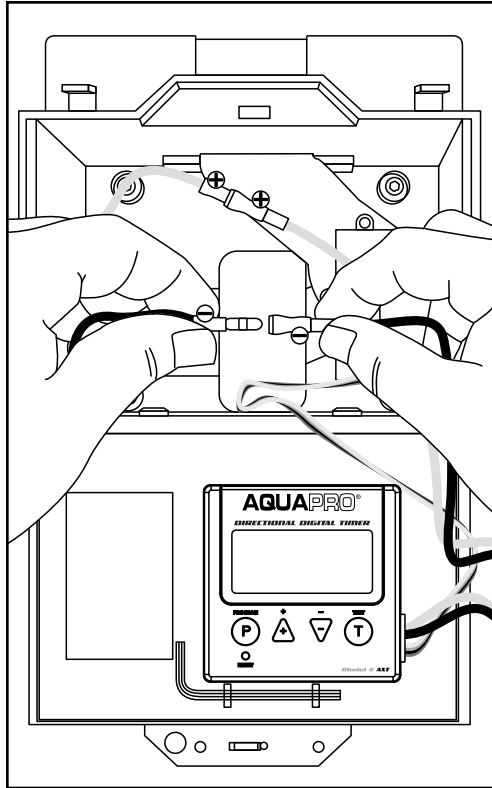

(Illustration M)

21 Find the clear disbursement chute and align the two ears on one side with the two holes located on the left hand side of the feed dispersement chamber and snap it into place. (Illustration N)

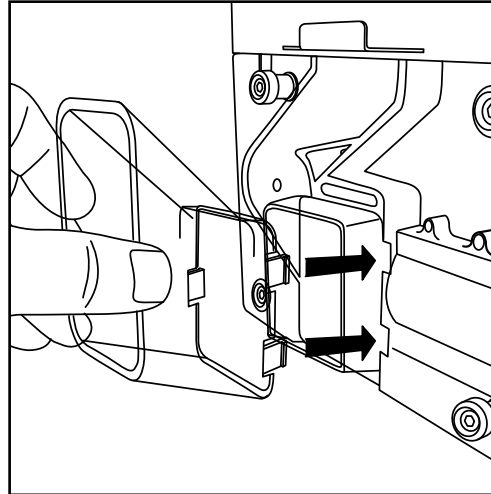

(Illustration N)

22 Once the unit is mounted, the timer hooked up, and the clear disbursement chute attached, you can then hookup to the battery. Use a 6V battery, preferably a sealed lead acid battery for optimum performance.

OPERATING INSTRUCTIONS

Once a suitable location for the feeder is identified and the unit is in place, remove lid and fill container with feed/seed to desired capacity.

Read the timer unit instructions carefully in order to set the current time, feed times and feed time durations as per your requirements.

Please refer to the timer operating instructions for the respective power control unit to identify exactly how to operate the power control unit.

Once the time, feed times and feed time durations have been set, run the power control in test mode to insure the settings meet your feeding requirements.

GENERAL SAFETY

Be very careful when operating the unit. This directional power control unit dispenses feed in a pie shape pattern at a **high velocity** and can cause serious bodily damage if not careful. Keep head and eyes clear of spinner plate and feed dispersement area when the unit is running.

Always make sure that the unit is placed on level ground/surface and is level before you fill the hopper with any feed/seed. If the unit is not level and the hopper is full, you run the serious risk of the unit tipping over and causing harm to both you and the product itself. Always exercise caution and care when loading/filling the unit with feed material. Please make sure that you and the unit are properly

supported so there is no chance of anyone getting hurt.

SUGGESTED MAINTENANCE

To insure proper functionality and a long life, BA Products strongly recommends that you service your feeder at least once every year.

This feeder should have the hopper thoroughly cleaned out at least once a year. Some feed/seed types have the tendency to cake and may build up over time, thus reducing overall hopper capacity, clogging feed flow or generally interfering with the overall functionality of the feeder unit.

It is also important to check the bolts located at the hopper flange regularly to insure that they are securely tightened and have not come loose. With prolonged use in the field, animals and other forces may exert force against the feeder unit which may cause certain components of the feeder unit to loosen.

DISCLAIMERS

BA Products is not responsible for damage, expense or injury caused by the unauthorized use of, alterations to, improper connection of and abuse or neglect of the BA Products' feeder system.

Never lean a ladder against the feeder when filling. You must always use an alternative method to fill your feeder. The use of a ladder, or some other similar type mechanism, leaning against the feeder

is not recommended and strongly discouraged. This may result in damage to the unit or personal injury.

WARRANTY

BA Products will repair all material or workmanship defects free of charge for FOUR (4) YEARS after the date of purchase and thereafter the cost will vary per incident.

The warranty registration card **MUST** be completed and returned to BA Products within fourteen (14) days after the purchase date of the product.

Proof of purchase is **REQUIRED** and a copy must be mailed, with the warranty registration card, to BA Products for this warranty to be honored and in force.

This warranty **DOES NOT COVER** damage, expense or injury caused by unauthorized repairs, alterations, improper connection, shipping, abuse, theft, accident, neglect or collateral loss.

When returning product for service you **MUST** obtain a Return Merchandise Authorization (RMA) number from BA Products. Please include name, UPS address (no PO. Box), telephone number, RMA number and a complete description of the problem on all enclosed correspondence.

When possible pack product carefully in original carton. We are not responsible for damage incurred in returning items for repair.

CUSTOMER SERVICE

BA Products stands behind every product we manufacture for a four year product workmanship warranty and a strong commitment to customer service. If you are in need of customer service for missing parts or need assistance with the operation or assembly of your product, we encourage you to call one of our customer service representatives and let us assist you with your BA Products feeder system.

BA Products

602 Fountain Parkway, Grand Prairie, Texas 75050

Telephone: (800) 847-8269. Fax: (972) 352-6633

www.aquaprofishfeeders.com

Free Manuals Download Website

<http://myh66.com>

<http://usermanuals.us>

<http://www.somanuals.com>

<http://www.4manuals.cc>

<http://www.manual-lib.com>

<http://www.404manual.com>

<http://www.luxmanual.com>

<http://aubethermostatmanual.com>

Golf course search by state

<http://golfingnear.com>

Email search by domain

<http://emailbydomain.com>

Auto manuals search

<http://auto.somanuals.com>

TV manuals search

<http://tv.somanuals.com>