

H
A
N
D
B
O
O
K



ARCAM

Alpha 10/10P Amplifier

Front & Rear Panel Diagrams

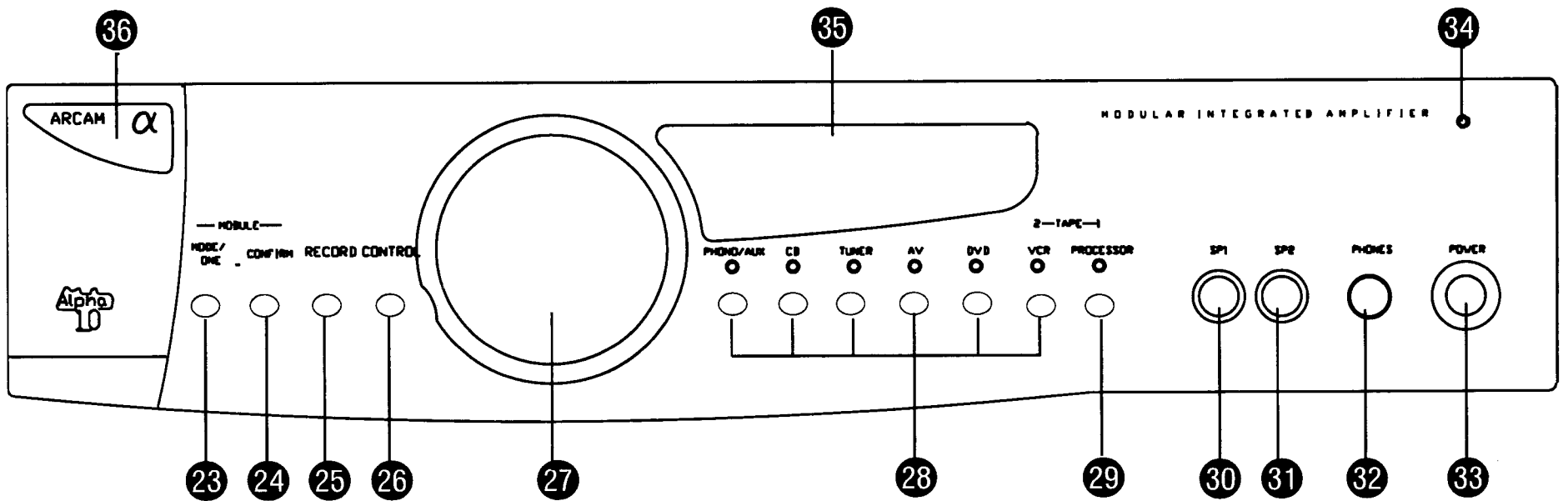
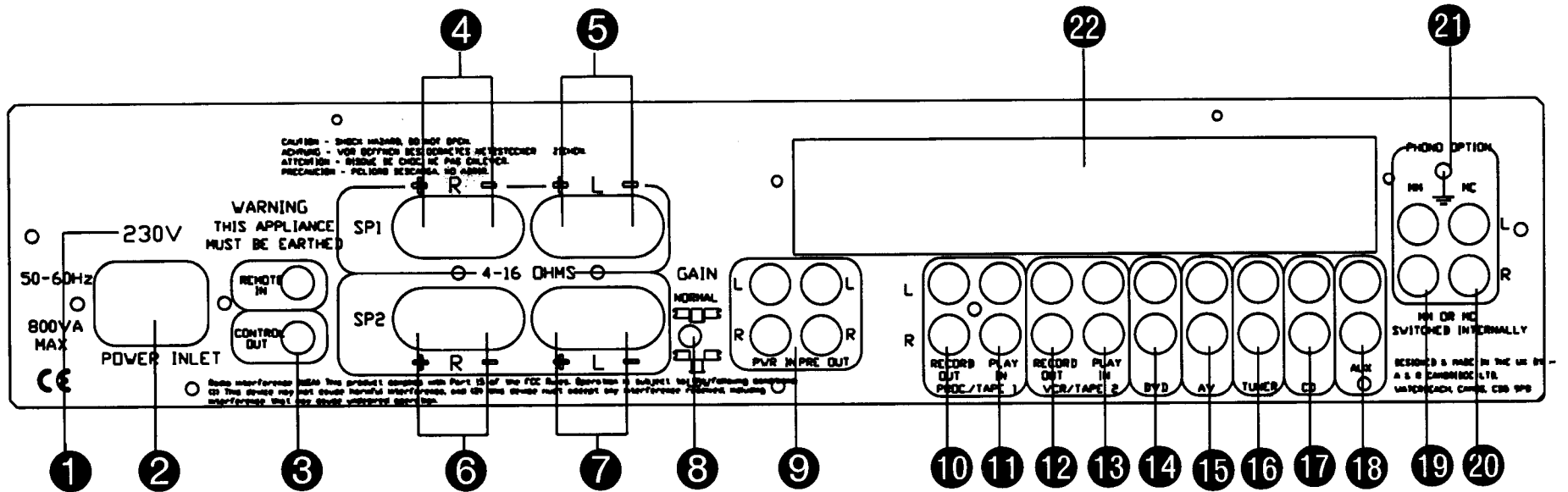

Alpha 10 Integrated Amplifier

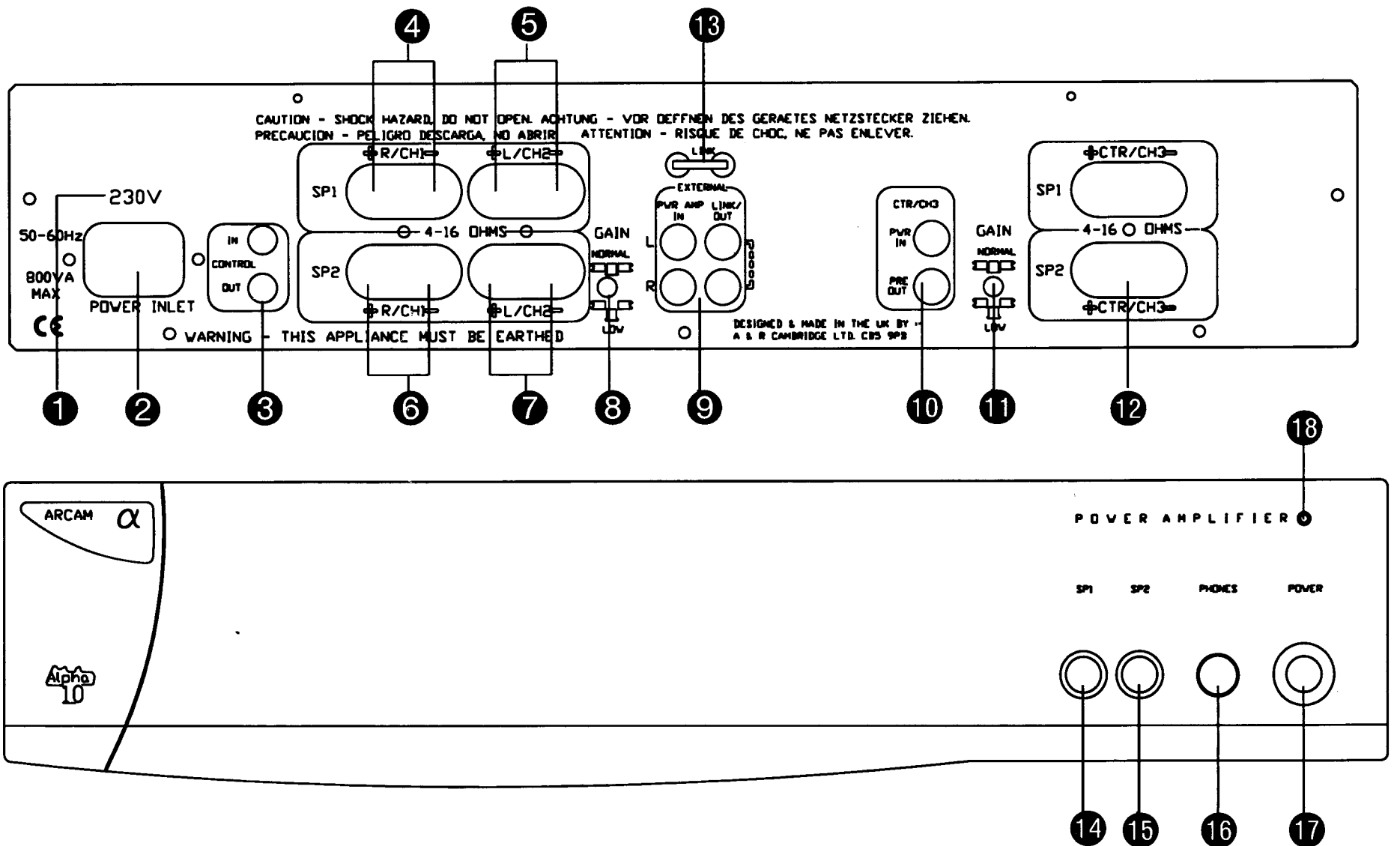

Alpha 10P Power Amplifier

SAFETY INSTRUCTIONS

This product was designed and manufactured to meet strict quality and safety standards. There are, however, some installation and operation precautions which you should be particularly aware of:

1. **Read Instructions** - All the safety and operating instructions should be read before the appliance is operated.
2. **Retain Instructions** - The safety and operating instructions should be retained for future reference.
3. **Heed Warnings** - All warnings on the appliance and in the operating instructions should be adhered to.
4. **Follow Instructions** - All operating and use instructions should be followed.
5. **Water and Moisture** - The appliance should not be used near water - for example near a bathtub, washbowl, kitchen sink, laundry tub, in a wet basement or near a swimming pool, etc.
6. **Carts and Stands** - The appliance should be used only with a cart or stand that is recommended by the manufacturer.
- 6A. An appliance and cart combination should be moved with care. Quick stops, excessive force, and uneven surfaces may cause the appliance and cart combination to overturn.
7. **Wall or Ceiling Mounting** - The appliance should be mounted to a wall or ceiling only as recommended by the manufacturer.
8. **Ventilation** - The appliance should be situated so that its location or position does not interfere with its proper ventilation. For example, the appliance should not be situated on a bed, sofa, rug or similar surface that may block the ventilation openings or placed in a built-in installation, such as a bookcase or cabinet that may impede the flow of air through the ventilation openings.
9. **Heat** - The appliance should be situated away from heat sources such as radiators, heat registers, stoves or other appliances (including amplifiers) that produce heat.
10. **Power Sources** - The appliance should be connected to a power supply only of the type described in the operating instructions or as marked on the appliance.
11. **Grounding** - Precautions should be taken so that the grounding means of the appliance is not defeated.
12. **Power-Cord Protection** - Power supply cords should be routed so that they are not likely to be walked on or pinched by items placed upon or against them, paying particular attention to cords and plugs, convenience receptacles and the point where they exit from the appliance.
13. **Cleaning** - Unplug the unit from the mains supply before cleaning. The appliance should normally only require a wipe over with a clean, dry, lint-free cloth. If it is heavily soiled then a cloth slightly dampened with a water/washing up liquid solution may be used. Dry the unit afterwards with a dry cloth. We do not advise the use of furniture type cleaning sprays/polishes as this can cause white marks, which are very difficult to remove, if the unit is then wiped over with water.
14. **Power Lines** - An outdoor antenna/ aerial should be located away from power lines.
15. **Non-use Periods** - The power cord of the appliance should be unplugged from the outlet when left unused for a long period of time.
16. **Object and Liquid Entry** - Care should be taken so that objects do not fall and liquids are not spilled into the enclosure through any openings.
17. **Abnormal Smell** - If an abnormal smell or smoke is detected from the appliance, immediately turn the power off and unplug the unit from the wall outlet. Contact your dealer immediately.
18. **Damage Requiring Service** - The appliance should be serviced by qualified service personnel when:
 - A. The power-supply cord or the plug has been damaged or:
 - B. Objects have fallen, or liquid has spilled into the appliance or:
 - C. The appliance has been exposed to rain or:
 - D. The appliance does not appear to operate normally or exhibits a marked change in performance or:
 - E. The appliance has been dropped or the enclosure damaged.
19. **Servicing** - The user should not attempt to service the appliance beyond that described in the operating instructions. All other servicing should be referred to qualified service personnel.

INTRODUCTION

This manual is in four sections:

- A. Information relevant to both the Alpha 10 and Alpha 10P.
- B. Alpha 10 integrated amplifier operating instructions.
- C. Alpha 10P power amplifier operating instructions.
- D. Instructions on how to bi-wire or to bi-amplify ("bi-amp") your loudspeakers.

Circindicator numbers e.g. ② refer to items on the diagrams inside the flap of the front cover.

Section A

INSTALLATION

- ① Check that your mains supply voltage agrees with the voltage setting indicated on the rear panel of the unit.
 - If your mains supply voltage is different, consult your Arcam dealer.

MAINS SAFETY

- This product is normally supplied with a moulded mains plug already fitted to the lead. If for any reason the plug needs to be removed, **it must be disposed of immediately and securely**, as it is a potential shock hazard when inserted into a mains socket.
- **Warning:** This apparatus must be earthed.

NOTICE FOR U.K. OWNERS ONLY

- If the plug is removed then the remaining lead must be rewired as follows:
 - The **blue** wire must be connected to the terminal which is coloured **blue** or marked with the letter **N**.
 - The **brown** wire must be connected to the terminal which is coloured **brown** or marked with the letter **L**.
 - The **green and yellow** wire must be connected to the terminal which is coloured **green and yellow**, or marked with the letter **E** or the safety earth symbol.
- When replacing the fuse in the supplied moulded mains plug, the integral fuse holder/cover must always be refitted. Use a 5 amp fuse.

SAFETY STANDARD

- This product has been designed to meet the IEC 65 international electrical safety standard.

MAINS SUPPLY CONNECTIONS

- ② Insert the IEC line socket of the mains lead fully into the power inlet on the rear panel. Connect the other end to your mains supply.

NOTES ON USE

The Alpha 10 and 10P amplifiers will play music within seconds of being switched on. However the optimum sound reproduction will be achieved after the units have been powered up for a few minutes.

Note: On switch on there may be an audible hum from the transformers within the units. This is normal and should disappear within a few seconds.

CAUTION: Your Alpha 10 and Alpha 10P generate heat when in use, particularly at higher volumes. It is therefore most important never to obstruct the ventilation slots on the top and bottom of the unit as this will cause overheating.

If the temperature of the internal heatsinks rises above a safe level, then a thermal cut out inside the amplifier will operate. The POWER INDICATOR on the front panel will turn amber and the output protection relays will temporarily remove the feed to the loudspeakers. The system will reset itself as the heatsinks cool down.

Please note that under certain conditions it may be possible for the Alpha 10 or Alpha 10P's thermal cut out to operate when playing music at very high levels.

This might for example happen when continuously playing heavily compressed rock music "flat out" into low impedance (4-6 ohm) speakers. If this happens to you, the cure is to turn the volume down slightly and ensure the amplifier is properly ventilated.

It is important to point out that when playing a heavily recorded CD it is possible to drive the Alpha 10 at full power despite the fact that the volume is not at maximum. This is because of the high output voltage from a CD player. However the Alpha 10 also has to be capable of giving full power output from much lower level sources, such as tuners and cassette decks. Using these sources, the volume setting will be much higher before overload sets in.

Section B

ALPHA 10 INTEGRATED AMPLIFIER

Please refer to drawing inside front cover.

LOUDSPEAKER CONNECTIONS

- The amplifier is fitted with BFA (British Federation of Audio) loudspeaker connectors, which are designed to meet EU safety standards. The BFA connector will accept spade terminals, bare wires or a BFA plug. BFA plugs are available from your Arcam dealer.
- The speaker terminals are colour coded red for positive and black for negative. These terminals are also labelled 'R' for the right channel speakers and 'L' for the left channel speakers.

Connect terminals ④ to your right speaker and terminals ⑤ to your left speaker, ensuring correct polarity.

- Connect the red cable termination to the red terminal and the other cable termination to the black terminal. If your speaker cable has bare ends, the positive conductor can usually be identified by a ridge or coloured marking.

Ensure that no stray strands are allowed to touch another cable or the amplifier's casing. This can cause a short circuit and damage your amplifier!

- 6, 7 To drive a second pair of speakers, connect terminals 6 to the right speaker and terminals 7 to the left speaker, ensuring correct polarity.

- The Alpha 10 can drive two pairs of loudspeakers, simultaneously if required, providing both pairs are rated between 8 and 16 ohms. Either pair can be selected using the switches labelled SP1 and SP2 on the front panel. To avoid overheating, the combined load impedance as seen by the amplifier should not fall below 4 ohms per channel.

CONNECTING YOUR SOURCE COMPONENTS

- Using a suitable pair of interconnect cables, insert the red phono plugs into the sockets labelled 'R' and the other phono plugs into the sockets labelled 'L'.

All the line inputs (not PHONO) have the same sensitivity and may be used with equipment other than that labelled, if you need to do so.

- 10 PROCESSOR/TAPE 1 RECORD OUT - Connect this output to the input sockets of your tape deck (RECORD) or the tape or line input sockets of your AV processor.
- 11 PROCESSOR/TAPE 1 PLAY IN - Connect this input to the output sockets of your tape deck (PLAY) or the tape or line output sockets of your AV processor.
- 12 VCR/TAPE 2 RECORD OUT - Connect this output to the input sockets of your tape deck (RECORD).
- 13 VCR/TAPE 2 PLAY IN - Connect this input to the output sockets of your tape deck (PLAY).
- 14 DVD - Connect this input to the audio outputs of a DVD player.
- 15 A/V - Connect this input to the audio outputs of an Audio-Visual product such as a VCR, Laserdisc player or Nicam tuner.
- 16 TUNER - Connect this input to the audio outputs of your radio tuner.
- 17 CD - Connect this input to the audio outputs of your CD player or DAC (digital to analogue convertor).
- 18 AUX - Connect this input to the audio outputs of any unit with a line level output, eg. tape deck, tuner etc.
Please note: The AUX inputs must not be used if the phono module is fitted. When the phono module is fitted AUX becomes an output carrying the equalised phono signal at line level.
- PHONO OPTION - **Please note:** The phono inputs are on a separate plug-in module which your Arcam dealer or distributor can supply and fit.

This module is compatible with most high output moving coil and moving magnet cartridges (MM) and low output moving coil cartridges (MC).

MM or MC is selected via an internal switch. Your cartridge type should be specified when the module is fitted.

- 19 MM - For connecting a turntable fitted with a high output moving coil or a moving magnet (MM) cartridge.
- 20 MC - For connecting a turntable fitted with a low output moving coil (MC) cartridge.
- 21 GROUND TERMINAL - For connecting your turntable's earth lead (if fitted).

OPERATION OF THE ALPHA 10 INTEGRATED AMPLIFIER

- 3 REMOTE CONNECTION - These connections are for use in multi-room installations. In normal use there is no need to make any connections to these sockets. If you are biamping with an Alpha 10P see section Alpha 10/10P Remote Switching for details of how to power both units on/off simultaneously.
- 8 GAIN - This switch allows you to change the sensitivity of the amplifier to match the gain when biamping to external power amp. The normal position is suitable for use when biamping with Arcam power amplifiers such as the Alpha 9P or 10P. The low gain position is suitable for certain specialist home theatre systems.
- 22 BLANKING PLATE FOR OPTIONAL FUTURE MODULES.
- 23 MODE/ZONE - 24 CONFIRM - These buttons are only for use with optional modules. They have no function on their own in normal use of the basic Alpha 10 although MODE/ZONE 23 can be used to select processor mode (see 29).
- 25 RECORD SELECTOR - This allows you to change the input that you wish to record from, from that selected by the INPUT SELECTORS. Alternatively this switch can also be used as a simple 'second zone' selector, routing a chosen source signal at line level to a second amplifier operating in another room in the house. The default setting is the input you are currently listening to ("SOURCE"). To select a different input to record from first press RECORD. The display will first show "RECORD SOURCE". To change the record input press the desired input button within a few seconds. The display will indicate the selected recording option for a few seconds and then revert back to showing the volume bar graph.
- The selected input will be sent to both the VCR/TAPE 2 and PROCESSOR/TAPE 1 record out sockets, unless you are using the TAPE 1 sockets in processor mode where it is sent to VCR/TAPE 2 only.
- 26 CONTROL - This button cycles through the functions that can be controlled by the rotary control 27. This can be either volume (the default setting) or balance, unless an optional module is fitted, in which case the options are determined by that module.

In volume mode the display shows bargraph indication of the volume setting. It will take about 2 or 3 full revolutions of the volume knob to go from zero to full output. In balance mode the rotary control allows you to vary one channel relative to the other. It is not possible to use the balance control to mute one channel completely.

- 27 **VOLUME/BALANCE** - Adjusts the volume level of the loudspeakers, preamp out and headphones. It can also be used in conjunction with the control button as a balance control (see 26).
The VOLUME setting can be controlled with the supplied remote control handset. Note that the control is not motorized so the knob will not move when adjusted remotely. If you operate the control too quickly it will not respond. This is to prevent accidentally setting the volume too high.
- 28 **INPUT SELECTORS** - Selects the input you wish to listen to. The selected signal also goes to both the VCR and PROCESSOR RECORD output sockets unless you have chosen to record from a different input to the one you are listening to (section 25). The inputs can also be selected by remote control.
- 29 **PROCESSOR/TAPE 1** - This is tape loop to permit you to monitor a recording made on a 3 head cassette deck. It can also be used to connect to an external surround decoder such as the Arcam Xeta 2. Selecting this input overrides the other input selectors 28.
To play back or to monitor the recording from a cassette deck attached to the PROCESSOR/TAPE 1 input press the processor button 29. 'TAPE' is shown on the display.
For use with an external processor the Alpha 10 can be put in to processor mode by first selecting PROC and then whilst holding in the MODE button 23 press the PROC button 29 again. The display will now show "PRO" in place of "TAPE". If the processor you are using is an Arcam Xeta 2 then press the PROC button again while holding in the MODE button so that "PRO2" is displayed.

The volume level of the Alpha 10 will now be fixed so that you can use the volume control of the external processor as a master volume control. Using the volume or mute buttons on the remote handset or the front panel control knob will have no effect whilst in processor mode. The unit will return to processor mode whenever 29 is pressed.

Once in "PRO2" mode the AV, TAPE 1, VCR and DVD buttons on the CR35 remote control will have no effect. This is because the Xeta 2 will also respond to these remote control codes and switch to the wrong input. If you want to change the input back for use as a normal tape input hold the MODE button in and press the PROCESSOR button until 'TAPE' appears on the display.

CAUTION: Do not set the Alpha 10 to processor mode if you have a cassette deck or other line level source attached to the PROCESSOR/TAPE 1 input. This is because selecting processor mode input will send a fixed volume signal straight into the power amplifier which could damage your loudspeakers.

- 30 **SP1** - Selects or defeats the main pair of speakers. Push the button in to select.

- 31 **SP2** - Selects or defeats the secondary pair of speakers. Push the button in to select.

Important note: If both switches are turned off then the amplifier will appear not to be functioning, as all speakers will be switched off!

- 32 **HEADPHONES SOCKET** - Accepts headphones rated between 8 ohms and 2k ohms fitted with a 6.3mm stereo jack plug. If you wish to listen on headphones only, use SP1 and SP2 (if necessary) to mute the speakers. The headphone socket is always active.

- 33 **POWER** - Switches the unit on and off. The unit can also be switched into standby by use of the remote control handset.

- 34 **POWER INDICATOR** - This will initially glow amber. After a few seconds, it will glow green. When the indicator glows amber, the speakers are disconnected and an internal protection circuit is activated. The power indicator will turn red if the unit has been put into standby mode by use of the remote control. Under certain conditions the power indicator may flash and a fault condition will be shown on the display 35. If this happens you should unplug the mains lead of the unit and leave the unit for a few minutes before reconnecting. If the fault condition persists unplug and contact your Arcam dealer.

- 35 **DISPLAY** - The display is a multi function type which can show information about the current operating parameters of the Alpha 10, such as volume setting, record input, etc.

- 36 **REMOTE RECEIVER** - The remote receiver is behind the badge in the top left hand corner of the unit. Ensure the remote receiver is not obscured or commands from the remote control handset will not be received.

TAPE RECORDING

- **Note:** The Alpha 10 must be fully powered up in order to record.
- Both sets of tape sockets are identical in sensitivity and suitable for use with almost any type of recorder (cassette, hi-fi VCR, reel to reel, DAT, etc.)
- Use the RECORD selector to route the required signal to a cassette deck connected to the TAPE 1 and TAPE 2 RECORD OUT sockets (see section 25).
- **TAPE TO TAPE DUBBING:** The Alpha 10 allows two way tape dubbing (copying) from TAPE 2 to TAPE 1 but NOT TAPE 1 to TAPE 2. For example, to copy from a cassette recorder connected to the VCR/TAPE 2 sockets to a cassette recorder connected to TAPE 1, first use the RECORD selector on the Alpha 10 to select "RECORD :VCR" (see section 25). This routes the TAPE 2 signal to TAPE 1's output. Then set the tape recorder connected to TAPE ONE sockets into its 'record' mode and the other to 'playback' mode to enable the transfer to take place. If you wish to monitor the transfer while it is taking place select TAPE using the TAPE 1/PROCESSOR button 29

9 PRE/POWER CONNECTIONS

PWR AMP IN - To use your Alpha 10 just as a power amplifier, connect the output of your pre-amplifier to the PWR AMP IN sockets. The Alpha 10's internal selector switch must be changed to disconnect the preamp stages of the unit. Contact your dealer or Arcam for more details.

Under these circumstances it has exactly the same specification and performance as an Alpha 10P power amplifier.

PREAMP OUT - To use your Alpha 10 as a pre-amplifier, connect the PREAMP OUT sockets to the input sockets of your power amplifier. With a power amplifier of the correct gain (e.g. An Arcam Alpha 9P or 10P) this allows you to bi-amplify ("bi-amp") suitable loudspeakers, giving significant improvements in sound quality (see section on BI-WIRING/ BI-AMPING).

REMOTE CONTROL FUNCTIONS

- Your Alpha 10 amplifier is supplied with the Arcam CR35 infra-red remote control handset, which has buttons to allow the simple operation of other products. It is supplied with 2 AA batteries - ensure these are inserted correctly.
- The remote allows you to operate the Alpha 10 plus some basic functions of an Arcam or Philips based CD player (except the Alpha One CD player, which uses a different remote control language), a remote controlled tuner (such as the Alpha 8 tuner) and the Arcam Delta Black Box 500 DACC (Digital Audio Control Centre).
- To switch the unit to standby mode press 'STBY'. The power indicator will glow red. Press 'STBY' again to restore the unit to full power.
- The MUTE button mutes the speaker connections and pre-amp outputs. Both tape outputs and the headphone socket remain active. In MUTE mode "MUTE" will be shown on the display until mute is disabled by either pressing MUTE again or pressing volume +/-.
- To select the brightness of the display press the button marked 'DISP' in the amplifier section of the remote handset to cycle through the brightness levels, off, dim or fully on. If the display is switched off pressing any front panel button, except SP1, SP2 or MODE/ZONE, or a button on the amplifiers remote control will cause the display to illuminate for a few seconds before switching off again.

Section C

ALPHA 10P POWER AMPLIFIER

Please refer to drawing inside front cover.

LOUDSPEAKER CONNECTIONS

Connect up as per instructions for the Alpha 10 integrated amplifier.

CONNECTING YOUR SOURCE COMPONENT

- 9 **PWR AMP IN** - Connect this input to the output sockets of your pre-amplifier or the PREAMP OUT sockets of an integrated amplifier.

- 13 **MONO LINK** - The Alpha 10P can be configured to provide two mono loudspeaker outputs from a single input.

Using the U-link 13 supplied, connect the LINK OUT sockets together.

Utilising one Alpha 10P per loudspeaker in this manner will allow bi-amplifying of bi-wireable loudspeakers. This is particularly beneficial for top quality stereo installations with a separate pre-amplifier, or for the left, centre and right channel loudspeakers in a five speaker Dolby Pro Logic system. Contact your Arcam dealer for more detailed information.

- **Daisy Chain** - The Alpha 10P is capable of driving further Alpha 10P amplifiers (or any other power amplifier), to drive more speakers (eg. those in other rooms or tri-amplified speakers etc). Connect the extra power amplifier inputs to the LINK OUT sockets of the Alpha 10, left to left, right to right.

FRONT PANEL

- 14, 15 **SP1 and SP2** - Pressing the SP1 switch turns on the speakers connected to the SP1 (upper) set of output terminals on the rear panel. Similarly the SP2 switch turns on the speakers connected to the SP2 (lower) set of output terminals.

- Both the SP1 and SP2 switches can be turned on at the same time, provided that the combined impedance of the two pairs of speakers does not fall below 4 ohms per channel.
- The SP1/2 switches will also connect/disconnect speakers attached to the 3rd channel option if fitted.

Important note: If both switches are turned off then the amplifier will appear not to be functioning, as all speakers will be switched off!

- 16 **HEADPHONES SOCKET** - Accepts headphones rated between 8 ohms and 2k ohms fitted with a 6.3mm stereo jack plug. The headphone socket is always active.

- 17 **POWER** - Switches the power on and off.

- 18 **POWER INDICATOR** - This will initially glow amber. After a few seconds, it will glow green. When the indicator glows amber, the speakers are disconnected and an internal protection circuit is activated.

ALPHA 10/10P REMOTE SWITCHING

By making a connection from the "control out" socket 3 of the Alpha 10 to the "remote in" socket of the Alpha 10P power amplifier you can use the Alpha 10 to control the power mode of the power amplifier.

If configured in this way the front panel power button of the Alpha 10 (or remote control standby button) will switch both amplifiers on or off simultaneously. This facility allows you to hide the power amplifier out of sight and still be able to control its functions.

The connecting cable required is a 3.5mm to 3.5mm jack lead (stereo or mono) and it is possible to connect several 10P power amplifiers to an integrated Alpha 10 by "daisy chaining" from "control out" of one into the "remote in" of the next one, etc.

THIRD CHANNEL OPTION 10, 11, 12

This option enables you to have a 5 channel amplifier in two cases, when used in addition with a suitable power amp such as the Alpha 10P, for use in a high quality Home Cinema setup. The third channel can then be used to drive the centre speaker.

For connection details see instruction sheet included with third channel option.

Please contact your dealer for availability of this module.

BI-WIRING/BI-AMPING INSTRUCTIONS

Many modern loudspeakers are equipped with four connection terminals. This provides direct access to the high frequency and low frequency filter networks and associated drive units within the loudspeaker. Overall performance can be enhanced by making use of these separate connections.

WARNING: Do not make any connections to your amplifier while it is switched on and connected to the mains supply. Please check all connections thoroughly before attempting to re-connect the mains power supply. Always ensure that the volume control on your amplifier is set to a minimum before switching on.

BI-WIRING

Bi-wiring uses four conductors, one for each terminal, to enhance dramatically the performance of your loudspeakers. Bi-wiring eliminates the signal distortion arising from the low and high frequency currents interacting with one another within a single cable, as used in conventionally wired systems.

HOW TO BI-WIRE YOUR LOUDSPEAKERS

1. Remove the shorting links from each of the red and black terminal pairs on the rear of your loudspeakers.
2. You will need two lengths of loudspeaker cable per loudspeaker (which may be joined at the amplifier end) or a suitably terminated cable set capable of being used for bi-wiring in one length.

3. Connect the cables as per one of the diagrams opposite, dependant on your cable wiring, ensuring correct polarity at all times. The positive (+) connections on the right loudspeaker must go to the positive (+) connections on the right channel of the amplifier and the negative (-) connections on the right loudspeaker must go to the negative (-) connections on the right channel of the amplifier etc.

BI-AMPING

The performance of your system can be further enhanced over that achieved with bi-wiring, by extending the same principal one stage further to include separate amplification for the low and high frequency speaker drive units as well as separate loudspeaker cables. This is known as bi-amplifying, or bi-amping for short.

To implement bi-amping therefore requires four amplification channels. In practice this is done by using two stereo amplifiers; when one of these is an integrated amplifier it is best to use this drive the high frequency (HF) units whilst the outboard power amplifier is used to drive the low frequency (LF) units.

We recommend that you use identical amplifiers to avoid potential imbalances in sonic performance and sensitivities. The Alpha 10/10P combination is ideal. It is however possible to mix the Alpha 10 and the Alpha 9 range of amplifiers.

BI-WIRING USING BOTH SETS OF CONNECTIONS ON AMP

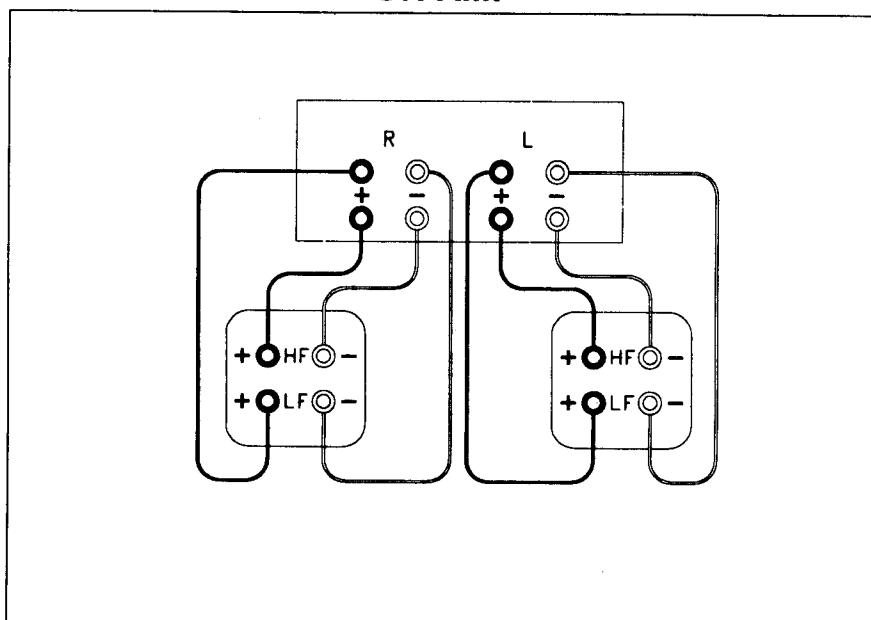

BI-WIRING USING ONE SET OF CONNECTIONS ON AMP

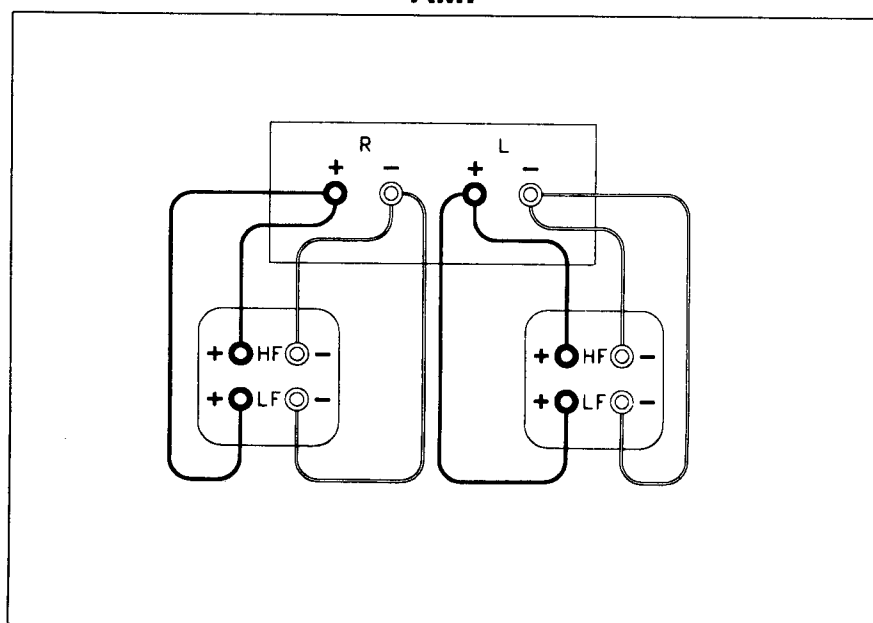

HOW TO SET UP A BI-AMPED SYSTEM

1. Remove the shorting links from each of the red and black terminal pairs on the rear of your loudspeakers.
THIS IS ESSENTIAL OR DAMAGE TO YOUR AMPLIFIERS MAY RESULT WHICH IS NOT COVERED UNDER WARRANTY.
2. You will need two lengths of loudspeaker cable (or a suitably terminated cable capable of being used for bi-wiring in one length) and one stereo amplifier per frequency band.
3. Connect your system as per the diagram opposite ensuring correct polarity at all times. The positive (+) connections on the loudspeaker must go to the positive (+) connections on the amplifier and the negative (-) connections on the right loudspeaker must go to the negative (-) connections on the right channel of the amplifier etc. You also need to make a connection from the preamp out sockets of your integrated amplifier, or preamplifier, to the power amp in sockets of the power amp.

- The Alpha 10 and Alpha 10P power amplifier are placed on separate shelves.
- The existing Alpha 10 should be used to drive the loudspeakers' HF (high frequency) units. The new Alpha 10P is utilised for the LF (bass) drivers, as shown in the wiring diagram below.
- High quality interconnect cables should be used between the Alpha 10 and Alpha 10P.
The use of high quality interconnect and speaker cables in your system is essential to obtain good sound quality. Contact your dealer or Arcam for further details and recommendations.
Note: The second set of speaker terminals (SP2) on both units can be used to drive extra loudspeakers in other rooms provided the impedance of these are 8 ohms or more.
- **WARNING - Ensure that the TERMINAL LINKS ARE REMOVED on the loudspeakers before switching on the amplifiers. Failure to do this could cause damage to one or both amplifiers and this is not covered under the warranty.**

ADDING AN ALPHA 10P TO AN EXISTING ALPHA 10 INTEGRATED AMPLIFIER

NOTE: Because of the weight of the Alpha 10 and 10P amplifiers we recommend that you do not stack them directly on top of each other.

If you are using an Alpha 10, an Alpha 10P can be added to bi-amplify a pair of bi-wireable loudspeakers. This will reap substantial improvements in sound quality if the following advice is observed.

BI-AMPING YOUR LOUDSPEAKERS

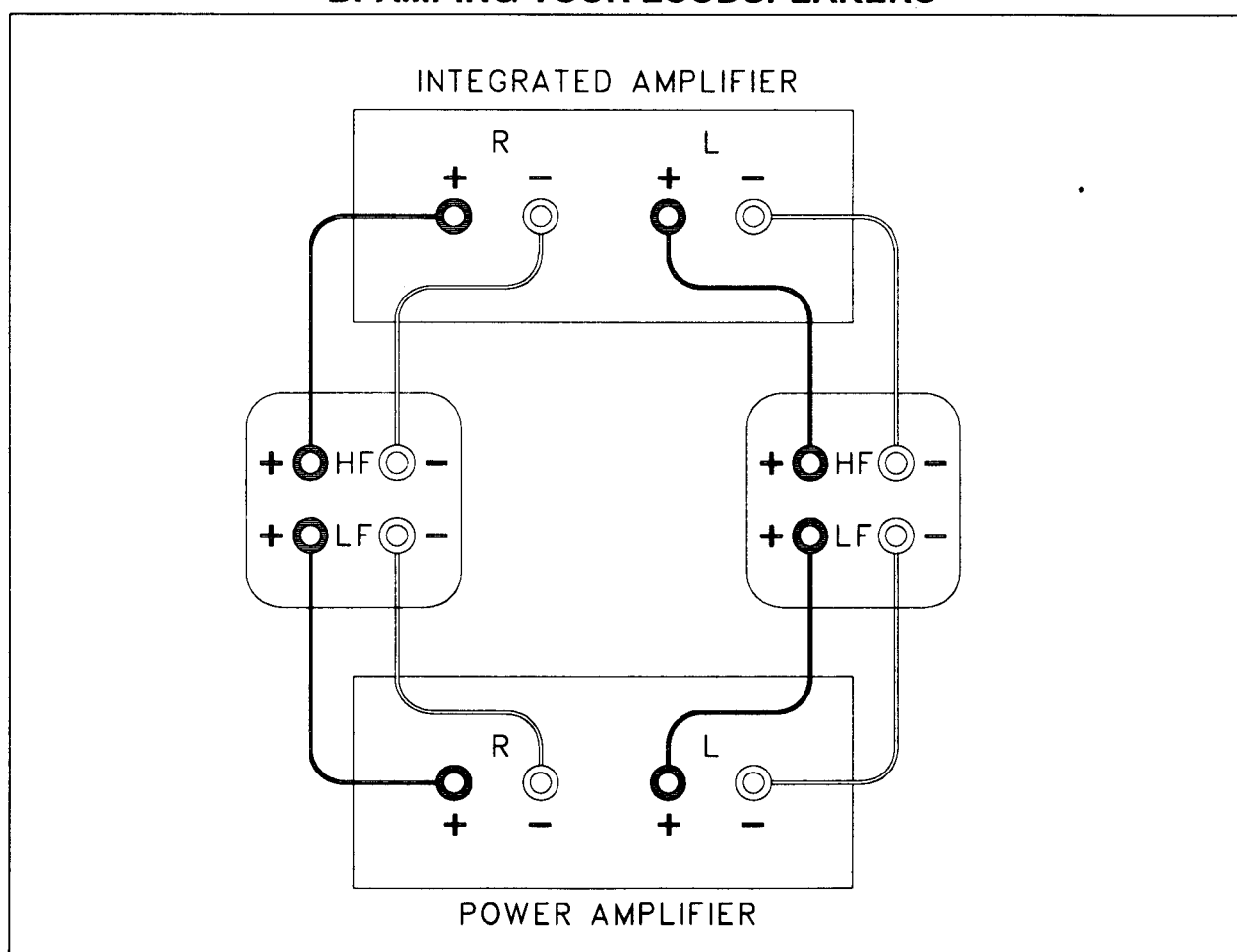

Guarantee Information

GUARANTEE FOR UK SALES

This equipment is guaranteed for two years from the date of purchase (parts and labour only), provided that it was originally purchased from an authorised dealer under a consumer sale agreement. (The words "consumer sale" shall be construed in accordance with Section 15 of the Supply Of Goods [Implied Terms] Act 1973).

The manufacturer can accept no responsibility for defects arising from accident, misuse, abuse, wear and tear, neglect or through unauthorised adjustment and/or repair, neither can they accept responsibility for damage or loss occurring during transit to or from the person claiming under this guarantee.

This guarantee is applicable within the UK only. It is transferable to subsequent purchasers, but the liability of the manufacturer is limited to the cost of repair of the defective parts and under no circumstances extends to consequential loss or damage.

CLAIMS UNDER THIS GUARANTEE

This equipment should be packed in the original packing and returned to the dealer from whom it was purchased, or failing this, directly to Arcam. It should be sent carriage prepaid by a reputable carrier - NOT by post. No responsibility can be accepted for the unit whilst in transit to the factory, or an agent, and customers are therefore advised to insure the unit against loss or damage whilst in transit.

If the original packing is not available, replacement packing can be purchased from Arcam.

DO NOT CONSIGN THE EQUIPMENT TO ARCAM UNLESS YOU HAVE BEEN SPECIFICALLY REQUESTED TO DO SO BY THE CUSTOMER SUPPORT DEPARTMENT.

DO NOT UNDER ANY CIRCUMSTANCES ATTEMPT TO DISASSEMBLE THE EQUIPMENT BEFORE DESPATCH.

You can contact the manufacturer at the following address:

ARCAM Customer Support Department,
Pembroke Avenue,
Denny Industrial Centre,
Waterbeach,
Cambridge,
CB5 9PB,
England.

Telephone: +44 (0)1223 203203

Fax: +44 (0)1223 863384

e-mail: custserv@arcam.co.uk

You should state clearly your name and address, the date and place of purchase together with a brief description of the fault.

In the event of equipment being returned which, after having been tested, is found to comply with the published specification, the manufacturer reserves the right to charge a reasonable fee for testing the equipment and for the return carriage.

THIS GUARANTEE IN NO WAY VARIES OR REMOVES A PURCHASER'S STATUTORY RIGHTS.

GUARANTEE FOR SALES IN THE EUROPEAN ECONOMIC AREA (EEA)

This unit is covered by a European Economic Area warranty, provided to you under the terms of Article 85 of the Treaty of Rome 1957.

This entitles you to have the unit repaired free of charge, during the first two years after purchase, at any authorised Arcam distributor within the EEA, provided that it was purchased from an authorised ARCAM dealer or distributor within the EEA.

The manufacturer can accept no responsibility for defects arising from accident, misuse, abuse, wear and tear, neglect or through unauthorised adjustment and/or repair, neither can they accept responsibility for damage or loss occurring during transit to or from the person claiming under this guarantee.

Countries of the European Economic Area are: Austria, Belgium, Denmark, Eire, Finland, France, Greece, Germany, Great Britain, Holland, Iceland, Italy, Lichtenstein, Luxembourg, Norway, Portugal, Spain, Switzerland and Sweden. This includes the Canary Islands, the Channel Islands, the Isle of Man, Corsica and Sardinia.

This warranty remains in force for two years from the date of purchase as long as the unit remains in free circulation. Units exported from the EEA and subsequently re-imported are not subject to this warranty.

CLAIMS UNDER GUARANTEE

This equipment should be packed in the original packing and returned to the dealer from whom it was purchased, or failing this, directly to the Arcam distributor in the country of residence. It should be sent carriage prepaid by a reputable carrier - NOT by post. No responsibility can be accepted for the unit whilst in transit to the dealer or distributor and customers are therefore advised to insure the unit against loss or damage whilst in transit.

For further details contact Arcam at:

ARCAM Customer Service Department, Pembroke Avenue, Denny Industrial Centre, Waterbeach, Cambridge, CB5 9PB, England.
Telephone: (01223) 203203 Fax:(01223) 863384
e-mail custserv@arcam.co.uk

GUARANTEE FOR SALES IN THE REST OF THE WORLD

This equipment is guaranteed in the country of purchase only, provided that it was purchased from an authorised ARCAM dealer or distributor.

The manufacturer can accept no responsibility for defects arising from accident, misuse, abuse, wear and tear, neglect or through unauthorised adjustment and/or repair, neither can they accept responsibility for damage or loss occurring during transit to or from the person claiming under this guarantee.

Full details of the guarantee can be obtained from the distributor in the country of purchase.

For your convenience a list of Arcam distributors is included on the rear of this leaflet. For any countries not listed please contact: Arcam Customer Services Department directly.

CLAIMS UNDER GUARANTEE

This equipment should be packed in the original packing and returned to the dealer from whom it was purchased, or failing this, directly to the Arcam distributor in the country of purchase. It should be sent carriage prepaid by a reputable carrier - NOT by post. No responsibility can be accepted for the unit whilst in transit to the dealer or distributor and customers are therefore advised to insure the unit against loss or damage whilst in transit.

PROBLEMS?

If your dealer is unable to answer any query regarding this or any other Arcam product please contact Arcam Customer Support on +44 (0)1223 203203 or write to us at the address on the back cover of this handbook and we will do our best to help you.

TECHNICAL SPECIFICATIONS

ALPHA 10 INTEGRATED AMPLIFIER	
Output power (20Hz-20kHz at 0.5%THD)	100W, both channels into 8Ω
	110W, single channel into 8Ω, 1kHz
	170W, single channel into 4Ω, 1kHz
Harmonic Distortion, 100W, 8Ω at 1kHz	0.02% typical
Peak current rating	± 25 amps
L/R Crosstalk	-80dB at 1kHz
INPUTS	
Line inputs:	Sensitivity 160mV
Noise (CCIR) ref. rated power	-100dB
Input impedance	10kΩ
Overload margin	30dB
Power amplifier	Sensitivity 740mV (Normal Gain)/1.0V (Low Gain)
Input impedance	7.5kΩ
Phono board (if fitted):	Sensitivity 2.6mV MM, 260μV MC
Noise (CCIR) ref. rated power	-79dB MM, -73dB MC
Input impedance	47kΩ MM, 300Ω MC
Overload margin	35dB
OUTPUTS	
Preamplifier Output	
Nominal output level	800mV
Maximum output level	8V
Output impedance	50Ω
Tape/ AUX outputs:	
Output impedance	50Ω
Headphones:	
Maximum output level into 600Ω	8V
Output impedance	100Ω
Mains voltage	230V/115V ±12%
Power consumption(max)	800VA (8VA Standby Mode)
Dimensions W/D/H mm.	430x380x110
Weight	nett 9.9kg packed 12.3kg
Supplied accessories	Mains lead CR35 Remote Handset (inc. batteries)

ALPHA 10P POWER AMPLIFIER	
Output power (20Hz-20kHz at 0.5%THD)	100W, both channels, 8Ω
	110W, single channel, 8Ω, 1kHz
	170W, single channel, 4Ω, 1kHz
Harmonic Distortion, 60W, 8Ω at 1kHz	0.02% typical
Peak current rating	± 25 amps
Input impedance	7.5kΩ
Input sensitivity	740mV (Normal Gain)/1.0V (Low Gain)
Frequency response	10Hz-20kHz ± 0.5dB
Noise (CCIR) ref. rated power	-100dB
Mains voltage	230V/115V ±12%
Power consumption(max)	800VA (8VA Standby Mode)
Size W/D/H mm.	430x350x110
Weight	nett 9.5kg packed 11.8kg
Supplied accessories	Mains lead

E & O E.

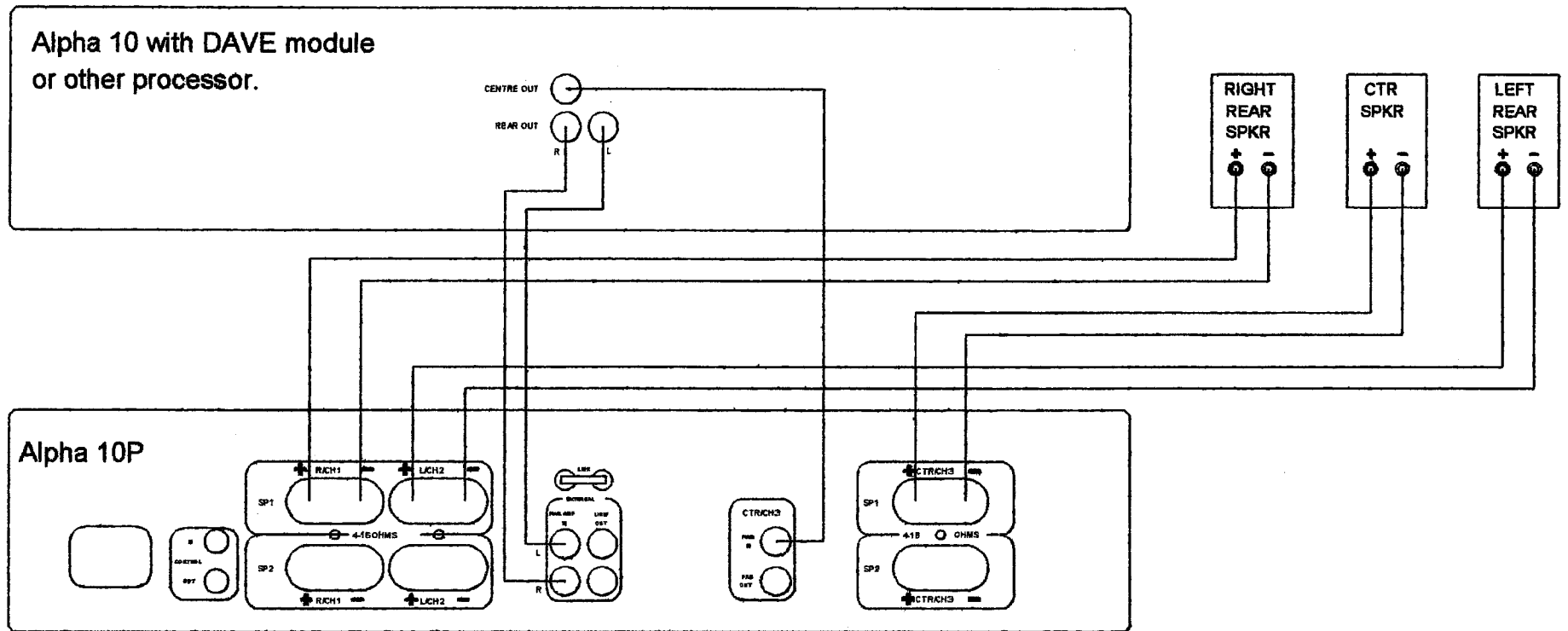

Figure 1

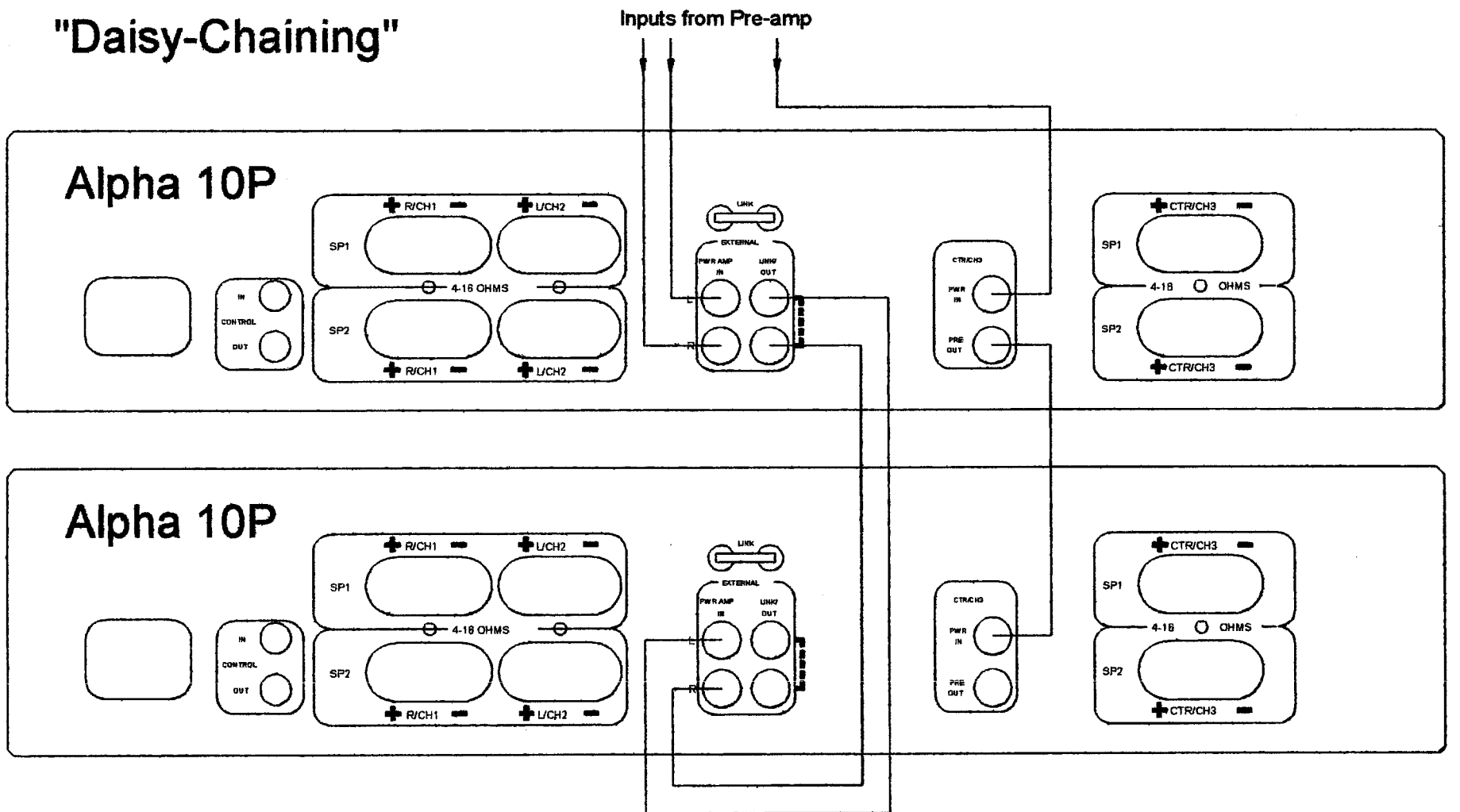

Figure 2

ALPHA 10 THREE CHANNEL POWER AMPLIFIER USER INSTRUCTIONS (TO BE READ IN CONJUNCTION WITH THE ALPHA 10/10P HANDBOOK)

Arcam Alpha 10 & DAVE Home Theatre System

The 3 channel Alpha 10P power amplifier can be used with the Alpha 10 integrated amplifier with its DAVE home theatre module to provide a very high quality 5 x 100W per channel system.

In this setup the Alpha 10 integrated is used to power your front left and right loudspeakers and the Alpha 10P power amp to power the centre and the two rear speakers.

Other Home Theatre Systems

You can use the 3 channel 10P with a 2 channel 10P to provide 5 x 100w of power amplification and another manufacturer's processor/preamp.

Three Channel 10P Connections

Connect the rear preamp out sockets of your processor to the PWR IN sockets ⑨ of the Alpha 10P ensuring that the left rear goes to the left PWR IN socket and the right rear goes to the right PWR IN socket.

Connect the centre preamp out socket of your processor to the 3rd channel PWR IN socket ⑩ of the 10P.

3rd Channel Option Part of 10P Rear Panel

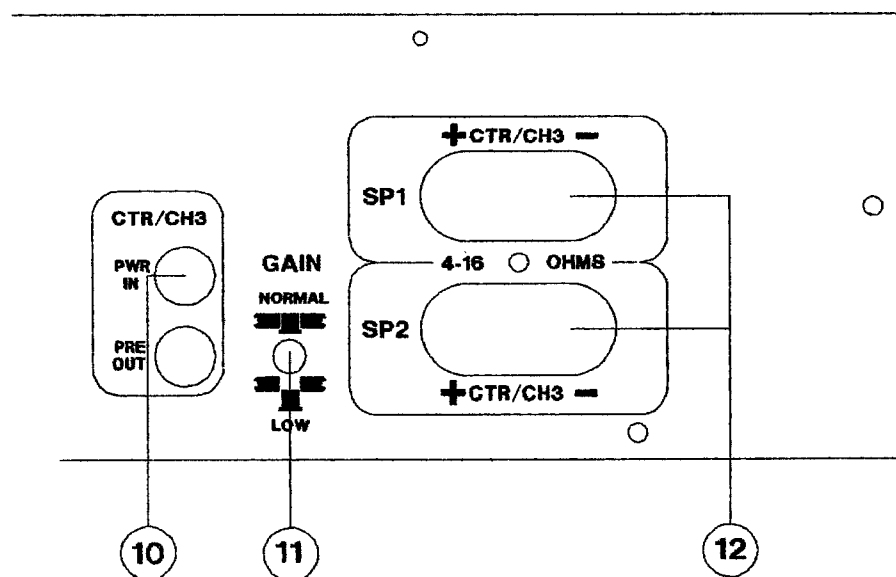

Connect the rear speakers to the speaker sockets ④ & ⑤ or ⑥ & ⑦ of the Alpha 10P. The centre speaker should be connected to the third channel speaker sockets ⑫ (See figure 1). You can use the SP1 set or the SP2 set or both if necessary.

If required you can use the sockets marked "Link/Out" or "Pre Out" on the 10P to 'daisy chain' to other 10Ps (see figure 2).

Please note :The front panel SP1 ⑳ and SP2 ㉑ buttons of the 10P will also turn off the speakers attached to the respective third channel speaker sockets.

Notice

DAVE / ALPHA 10

Switching Unit ON/OFF

If you wish to switch the amplifier back on immediately after switching off, please wait 30 seconds before doing so.

Should you switch the unit on immediately after switching off, the amplifier may fail to power up completely and go into a protection mode. This will not damage the amplifier or your loudspeakers. Switch off and wait 30 seconds before retrying.

ES24U1

Free Manuals Download Website

<http://myh66.com>

<http://usermanuals.us>

<http://www.somanuals.com>

<http://www.4manuals.cc>

<http://www.manual-lib.com>

<http://www.404manual.com>

<http://www.luxmanual.com>

<http://aubethermostatmanual.com>

Golf course search by state

<http://golfingnear.com>

Email search by domain

<http://emailbydomain.com>

Auto manuals search

<http://auto.somanuals.com>

TV manuals search

<http://tv.somanuals.com>