



LIBRA-04 M MANUAL COPY ROUTER



## **LIBRA-04 M MANUAL COPY ROUTER**

### **User's Manual**

**TABLE OF CONTENTS**

<b>ITEM #</b>	<b>SUBJECT</b>	<b>PAGE #</b>
I	<b>INTRODUCTION</b>	3
II	<b>SAFETY APPLICATIONS</b>	4
II.1	DESCRIPTION OF SYMBOLS USED IN THIS USER'S MANUAL	4
II.2	SAFETY INSTRUCTIONS	5
III	<b>MACHINE DESCRIPTION</b>	8
III.1	TECHNICAL DESCRIPTION	9
III.2	TECHNICAL DATA	9
IV	<b>INSTALLATION</b>	10
IV.1	MACHINE LIFTING AND MOVING	10
IV.2	THE REQUIRED OPERATION ZONE	11
IV.3	INSTALLATION AND ASSEMBLY OF MACHINE	11
V	<b>RUNNING THE MACHINE</b>	13
VI	<b>MAINTENANCE AND LUBRICATION</b>	14
VII	<b>TABLE OF PROBABLE PROBLEMS AND THEIR SOLUTIONS</b>	15
VII.1	WHEN PROBLEM OCCURS, THE PROCESSES THAT SHOULD BE DONE	15
VIII	<b>CIRCUIT DIAGRAMS</b>	17
VIII.1	PNEUMATIC CIRCUIT	17
VIII.2	ELECTRIC CIRCUIT	18

## **I. GENERAL INFORMATION**

### **1.1. INTRODUCTION**

The user's manual given by the manufacturer contains necessary information about the machine parts. Each machine operator should read these instructions carefully, and the machine should be operated after fully understanding them.

Safe and efficient use of the machine for long term depends on understanding and following the instructions contained in this manual. The technical drawings and details contained in this manual constitute a guide for the operator.

### **1.2. DISTRIBUTOR**

ATech Machine, Inc.  
7609-F Airpark Road – Gaithersburg, MD 20879 USA  
Phone: +1-301-556-9789 Toll Free: 1-866-80A-TECH Fax: +1-301-542-0140  
Website: [www.ATechMachine.com](http://www.ATechMachine.com) E-mail: [info@ATechMachine.com](mailto:info@ATechMachine.com)

In case of any technical problem please contact your nearest ATECH dealer through the above mentioned phone, fax or e-mail address.

Technical labels with the model description of the machine are fixed onto the front side of each machine.

The machine's serial number and manufacturing year are stipulated on the technical label.



Before using the Libra-04 M Manual Copy Router read the user's manual.

## II – SAFETY APPLICATION

- ✚ Before operating this equipment, be sure of reading and understanding the safety instructions.
- ✚ The operator may not run the machine without reading this guide.
- ✚ Reading and understanding this user guide is important for hindering to injury to the operator, third persons, animals, environment and/or damage to the machine.

### II.1 – DESCRIPTION OF SYMBOLS USED IN THIS USER'S MANUAL



This symbol express the definitions to give some information about the machine.



This symbol express that machine does not be operated without reading the user guide.



This express that security conditions that must be followed to prevent possible damage to the machine.



In this technical manual all information which effect your safety are marked with this warning symbol.

#### **Caution!**

The caution symbol is always used when there is danger of injury to persons.



This is hazardous voltage symbol.



This is general warning symbol. This rules must be obeyed.



This shows that attitudes should not be done without being expert.



This symbol indicates that there is a pinch point.



This explains the processes that should be done before maintenance.



This explains not be pulled up the protective parts. Do not operate without guards.



This is high temperature symbol.

## II.2 – SAFETY INSTRUCTIONS



Before operating this equipment, read the safety instructions and carry out them.



This technical handbook should be accessible at all times at the site of operation of the machine.



The operators who work during the installation, should read the machine guide. Be sure of understanding.



User should not intervene to the machine if occurs any failure. Only expert should repair the machine.



Machine and parts should be protected from the all external defects. Check for proper oil level before operating machine. If it is insufficient, add up.



Do not stay under machine during loading and discharge.



Never use the machine without grounding. Machine grounding should be made for two different coupling.

- 1-) Normal machine grounding.
- 2-) PLC grounding.



While machine is run or set up for angular cuts, be careful about pinching your hand to clamping pistons.



When transmission parts of machine abrade, they should be replaced with new ones.



Use only original spare part.



Don't lean against control panel and do not force.



Use e-Stop button when necessary for stopping the machine because very frequent repetition of this process, may cause problems on the some electric components.



Service personnel of our company is responsible from the first operation of machine. Do not allowed to run the machine any other person.



In the event of the machine failure, if there is a problem about electric, electric panel should be opened by experts and again eliminated the problem by them.



Do not operate the machine except intended purpose.



----

Don't touch the cables which are in the machine.



Do not wear clothes that hamper manufacturing and endanger the human safety while the operator run machine. Never operate the machine when you get alcohol or drug.



While machine is running, don't make repairs, adjustments and maintenance.



Never remove protective machine parts on the machines. Do not forget that such protective machine parts are put in order to protect your security.



Never touch the heaters of machine.



Only one person should operate the machine.



Before the machine stops don't open the safety covers.



Disconnect electrical power hydraulic and air pressure before making repairs or adjustments.



Do not run the machine in the watery and moist areas.



Machine should be adjusted and well-kept all the time. Never do not work with broken machine.

### III –MACHINE DESCRIPTION

LIBRA-04 M Manual Copy Router is used for milling lock holes, hinge slots, and handle mounting holes onto vinyl (PVC) and aluminum profiles.



**LIBRA-04 M**

**Picture 3-1 General View**





## IV – INSTALLATION

The Libra-04 M Manual Copy Router is factory tested to ensure that the electrical system and all mechanical components work properly. All material and spare parts sent from the factory have been thoroughly checked before consignment to the transportation agency.

On receiving the equipment, check for any damage which may have occurred during transportation.



### IV.1 – MACHINE LIFTING AND MOVING

The equipment is delivered in its own special packing. Check the stability and positioning of the load on the forks. Keep the load as low as possible when moving, for greater stability and better visibility. Forks should be opened with maximum angle.

1. When carrying, make sure not to damage cables, cylinders, hose, regulator and control panel.
2. Upon carrying, avoid to get a damage to the machine.
3. Carrying the machine must be done only with a proper size of forklift.



Before lifting, ensure that the lift truck fingers are clear of any wires that may be damaged if pinched between the fingers and the machine.

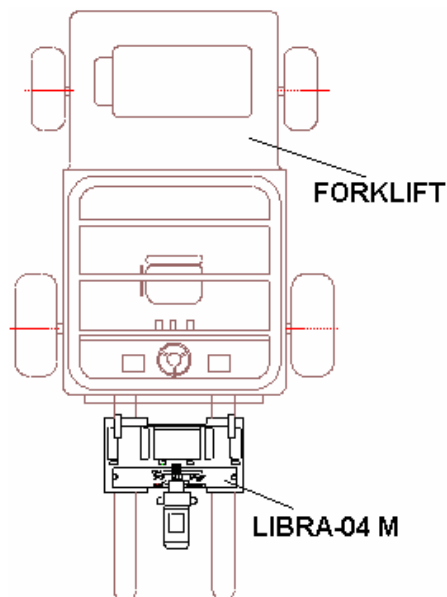

**Picture 4-1 Machine Lifting and Moving**

## IV.2 – THE REQUIRED OPERATION ZONE

ATech recommends a minimum of 100 cm (40") clearance on the front, a minimum of 30 cm (12") clearance at the back side of the entire assembly and a minimum of 150 cm (59") clearance on the sides.



The following figure shows the recommended minimum safe operation area.

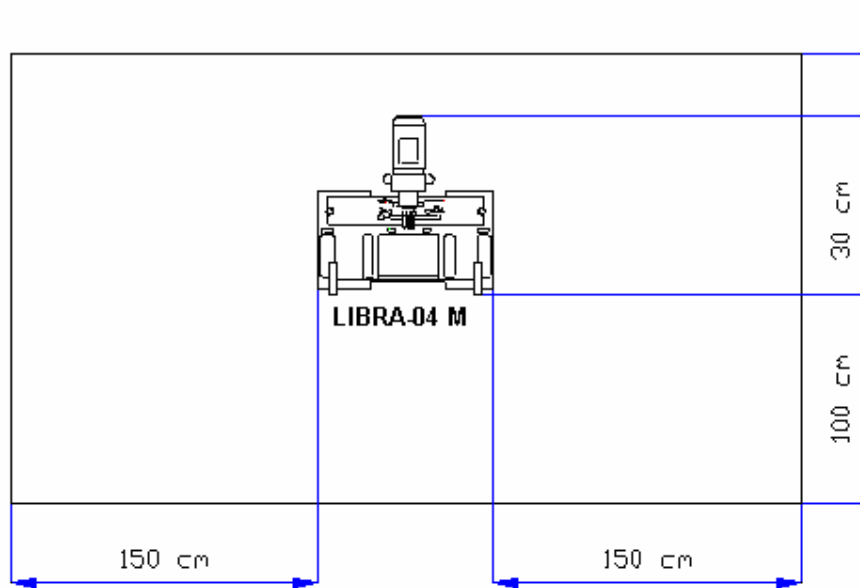

Figure 4-2 The settlement of machine

## IV.3 – INSTALLATION and ASSEMBLY OF MACHINE

Ensure that the ground is even and level. Ensure that there is sufficient space around the machine for easy maneuvering, safe operation and servicing / maintenance access.



The electric connection of the machine has to be carried out by a qualified electrician. Routing panel should be of high quality. A good grounding system is very important because it will prevent possible electrical injury.



Voltage fluctuation, low and high voltage are very dangerous for the machine. Use voltage regulator to prevent these problems. Otherwise, ATech is not responsible for possible defects.



Pressure for air should read 6 to 8 bar (90-120 psi). Using hose with a large diameter may prevent loose of air pressure along the long line. Also the air should never contain moisture to not damage to the valves and pistons.



Machine should be balanced. A good balanced machine increases production quality, decreases machine shake and makes simpler running the axes.

## V – RUNNING THE MACHINE

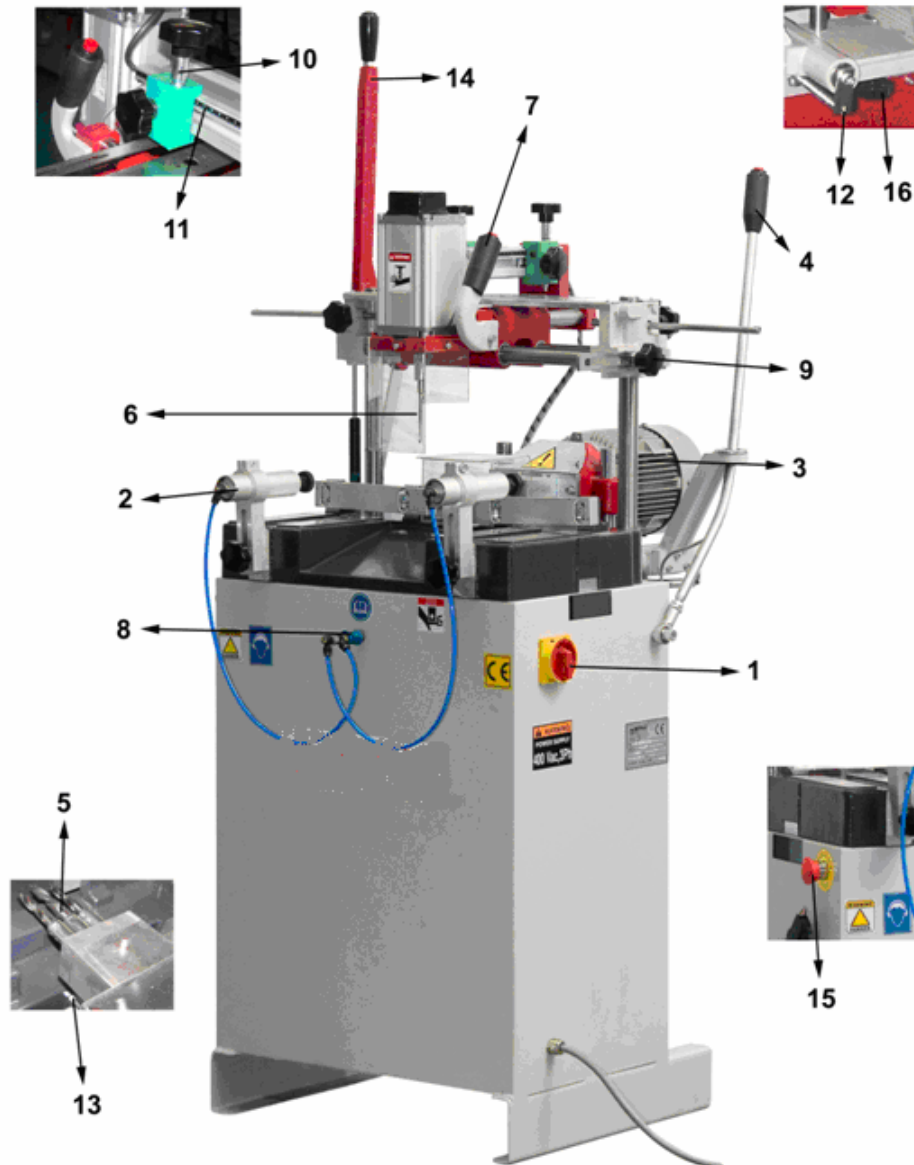
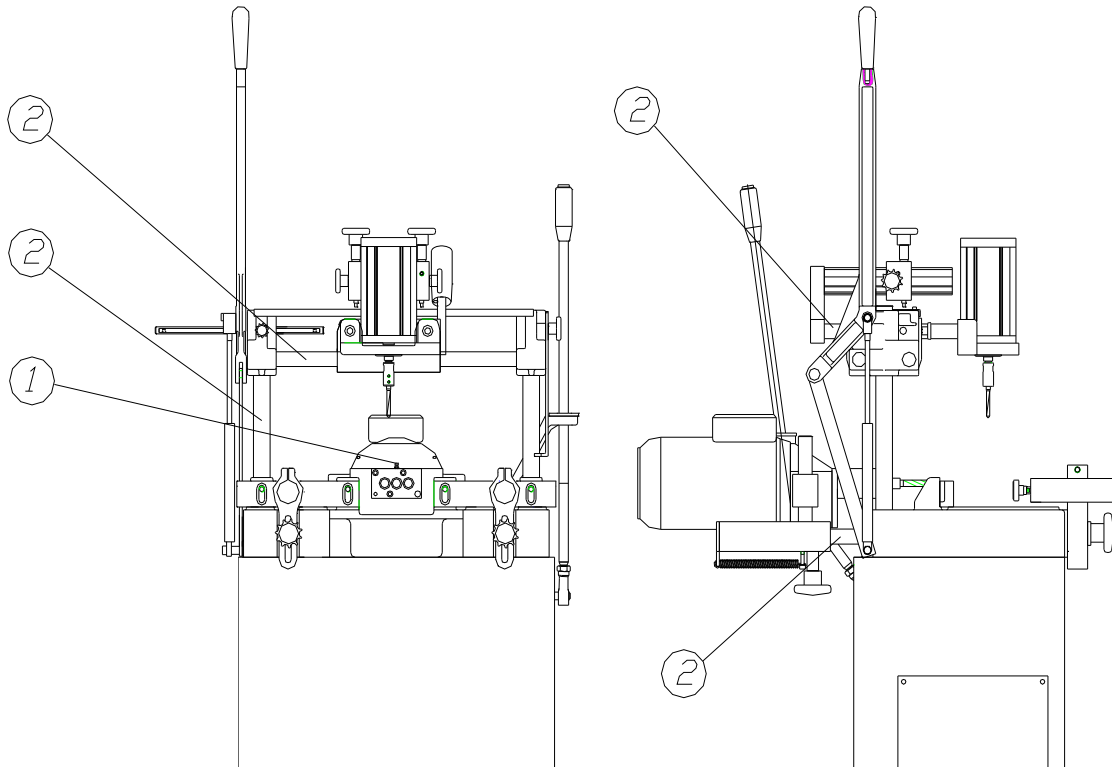

Figure 5-1 Machine parts

## MILLING PROCESS

Turn on the main power switch, put the profile onto the setsquare and clamp it with the clamping pistons. The tracer pin must be placed into the template which is to be copied. Copy motor is run. Set the drill bit (router bit) into profile by copy vertical movement handle. Deep drilling is adjusted with part. Drill the channel with copy movement knob. Slowly release the vertical copy movement handle after the process is completed. Milling cutters go up.

## VI –MAINTENANCE AND LUBRICATION



**Figure 6-1 Maintenance and lubrication**

- **M6 Grease Cup:** is lubricated with grease pump.
  - **Guiding shafts:** are lubricated with thin oil.
  - Disconnect electrical power hydraulic and air pressure before doing maintenance.
  - The main power switch should be turned to the “Off” position
  - Disconnect air entry of machine from the compressor air exit to prevent air completely.
  - Only recommended maintenance and lubrication products should be used.
- Shavings that accumulate on machine should be cleaned daily.

Electric cabinet should be cleaned from dust and shaving with air once in six months.

- If clamp pistons do not press the profile, pressure should be controlled and adjusted from the conditioner.
- Machine needs at least 6 bar (90 psi) air pressure. Make sure to maintain this.

## VII – TABLE OF PROBABLE PROBLEMS AND THEIR SOLUTIONS

### VII.1 - WHEN PROBLEM OCCURS, THE PROCESSES THAT SHOULD BE DONE

#### VII.2 TROUBLESHOOTING

PROBLEM	POSSIBLE REASON	SOLUTION
No movement	Electrical failure  Failure of air connection	Check the safety power switch, fuses, entry phases and air connections.
Motors do not run	Electrical failure	Check the safety power switch, fuses, entry phases, frequency converter, (4), (7) numbered buttons and thermic.  Look at frequency converter
Motor run but triple drilling edges do not turn	Triple drilling head is broken	Call service person.
Drill is not working properly. It drills hardly	Drill edges become blunt.	It is changed with new one.
Clamping pistons do not run	Failure of air connection  Valve failure	Check the air connections.  Check the valve.



If the machine seems like normal completely, read the user guide again by running the machine with the method of finding out the breakdown step by step. If problem still occurs, call the service.



# VIII – CIRCUIT DIAGRAM

## VIII.1 – PNEUMATIC CIRCUIT

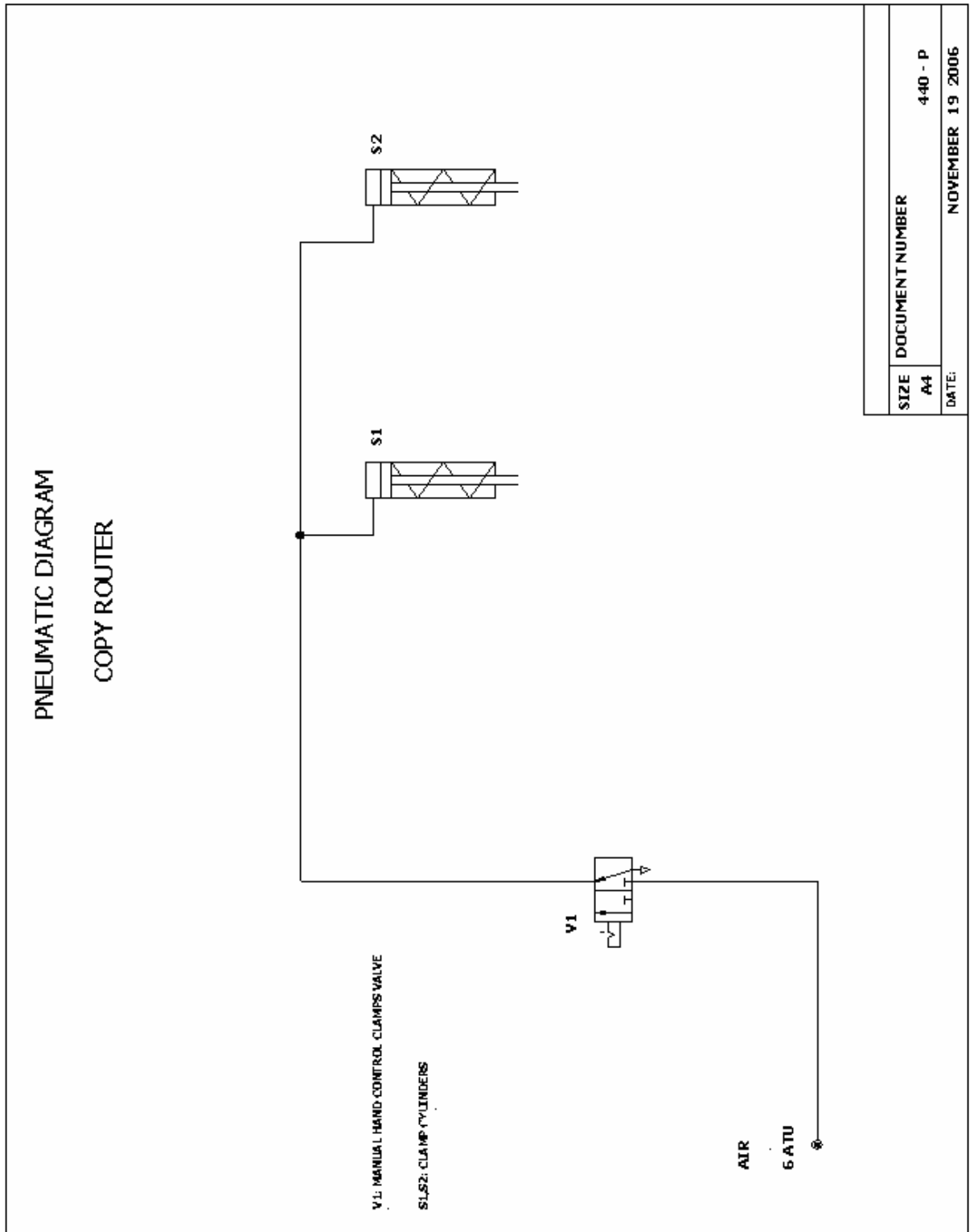

## VIII.2 –ELECTRIC CIRCUIT

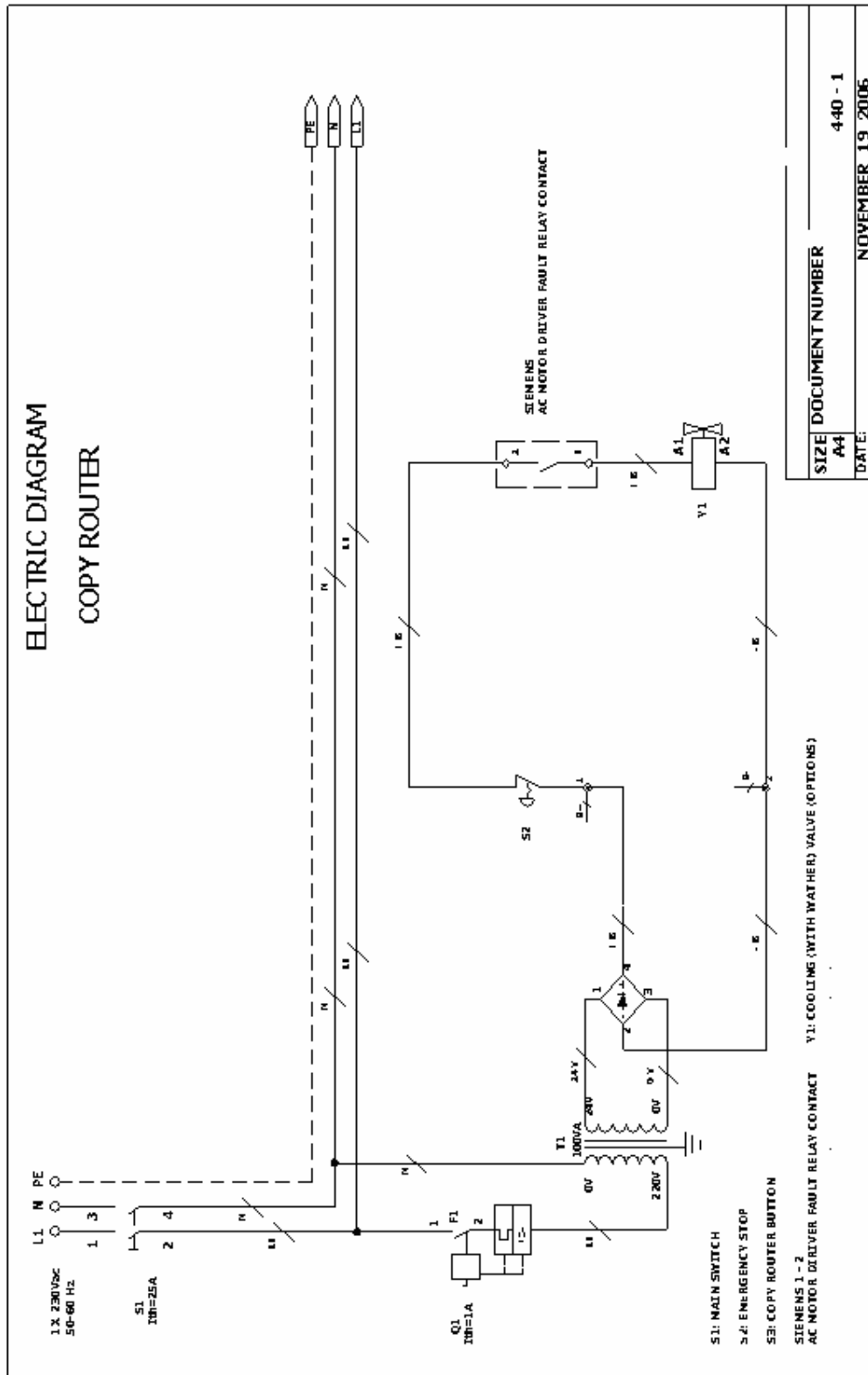

ELECTRIC DIAGRAM  
COPY ROUTER

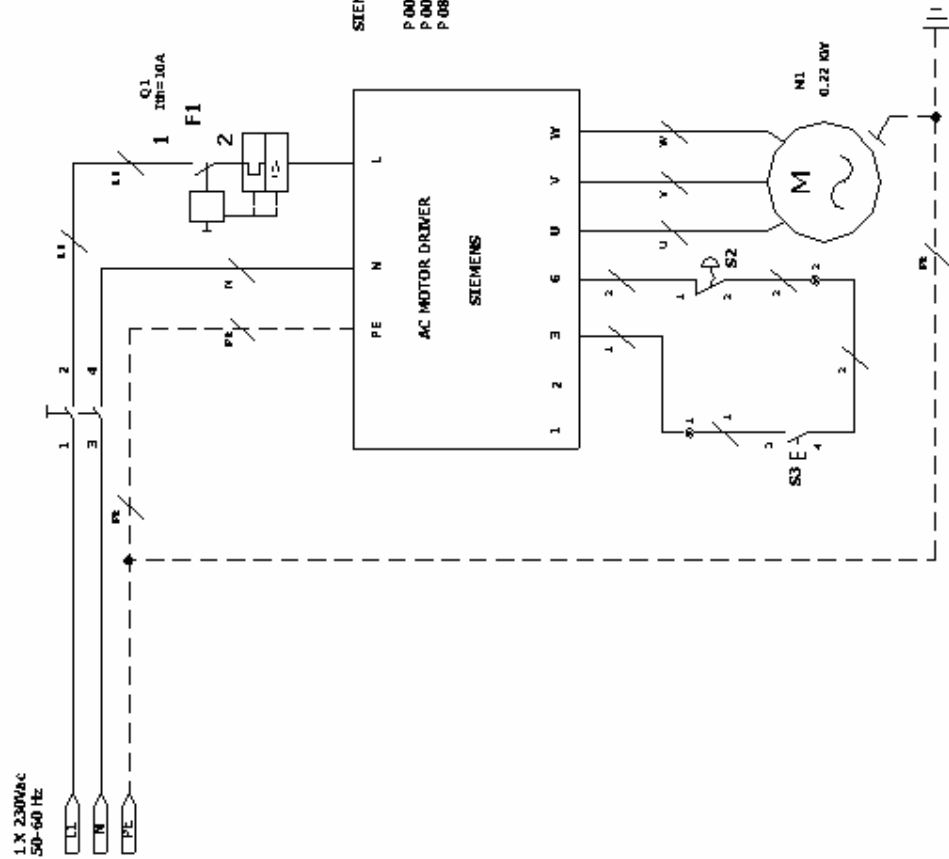

SIEMENS DRIVER PARAMETERS

P.0003 : 3  
P.0010 : 30  
P.0803 : 1

SIZE	DOCUMENT NUMBER
A4	440 - 2
DATE:	NOVEMBER 19 2006

## Free Manuals Download Website

<http://myh66.com>

<http://usermanuals.us>

<http://www.somanuals.com>

<http://www.4manuals.cc>

<http://www.manual-lib.com>

<http://www.404manual.com>

<http://www.luxmanual.com>

<http://aubethermostatmanual.com>

Golf course search by state

<http://golfingnear.com>

Email search by domain

<http://emailbydomain.com>

Auto manuals search

<http://auto.somanuals.com>

TV manuals search

<http://tv.somanuals.com>