

# Installation Instructions

Thank you for purchasing Atlantic Technology speaker products. These unique, TriMode speakers solve myriad surround sound and distributed audio installation problems. We work very hard to ensure that all of our speakers consistently deliver exceptional performance and value. We hope you enjoy them to their fullest. Please take a moment to read these instructions so you can get the most from your speakers.

## Mounting Specifications

These speakers are intended for mounting in a ceiling, in material ranging from 0.5 inches to 1 inch thick. They require at least 3-7/8 inches for the 6 CMS and 4-1/4 inches for the 8 CMS clearance behind the *front surface of the ceiling*. The mounting opening for the 6 CMS is 7-7/8 inches in diameter. The mounting opening for the 8 CMS is 9-1/2 inches in diameter. These speakers will work equally as well in a wall as in a ceiling, however note that the 8 CMS requires more mounting depth than is normal in a 2x4 studded wall.

## Operating Modes and Locations

**Mono Mode** Use Mono mode when the speaker will play a single channel of information (as *either* the left or right channel of a stereo pair of speakers). When used in Mono mode, both tweeters reproduce the same signal. In Mono mode the speaker can be located anywhere within the listening area. Generally however, it's best to keep it at least 24 inches away from any wall boundaries (ceiling/wall/corner). Placing any speaker in close proximity to other boundary surfaces will always "color" the sound that the speaker produces. Even speakers that incorporate frequency adjustments to compensate can only make small improvements to the detrimental effects of boundary reflections. The more directly under the speaker you are, the more high frequency information you will hear. Should you be using two speakers in Mono mode to reproduce stereo, consider where the majority

of the room's occupants will be most of the time. Then try to locate the speakers where the listeners will get a reasonable balance of sound from both speakers. When wired in Mono mode the tweeters interact strongly, changing the dispersion pattern of the high frequencies as shown in Figure 1.

**Important Note:** *DO NOT rotate the tweeter assembly or damage will occur. To achieve the desired dispersion pattern, rotate the entire speaker assembly before mounting.*

This can and should be used to your advantage by rotating the speakers in order to align the tweeters when you mount them. This way you can exert some control over the spread of mid

Model IWTS-8 CMS

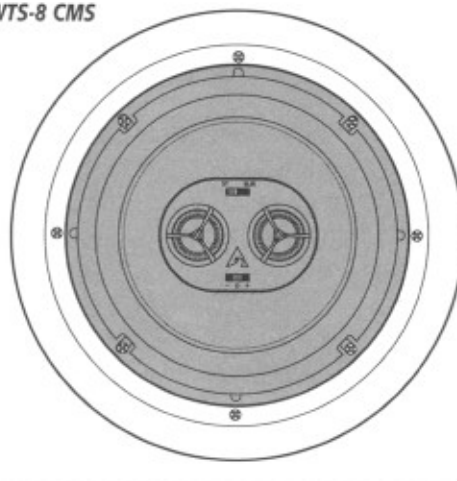

and high frequency sound throughout the room and hence improve the system's performance.

**Stereo Mode** In Stereo mode each of the woofer's dual voice coils and the tweeters receives their own signals. The result is stereo reproduction (albeit with limited separation) from a single speaker. This is particularly advantageous in distributed audio systems where there is a desire to have stereo sound in many rooms, but with as few speakers as possible. Unlike so many ceiling speakers, the 8 and 6 CMS use very high quality component parts and sophisticated designs to deliver excellent sound quality; sound quality so good that it will surprise you. When installed as a single point stereo speaker it's typically best to locate the speaker as centrally within the listening area as possible. Directly in the center of the room, or in the middle of the prime seating area.

**TriVector™ Surround Mode** TriVector mode puts the two tweeters in each speaker out of phase with each other. The result, when you sit centered on the tweeter array, is a non-localizable sound field that helps re-create the surround field intended by the movie's director. Since the goal of Home Theater is to get you "lost in the movie," a diffuse surround field almost always works best. To that end the ideal location for most diffuse surround speakers is directly to the sides of the prime listening area. However, in many rooms there's simply no place to conveniently place speakers to the sides. Until the introduction of Atlantic's TriVector ceiling surrounds, the ceiling was an often used, but generally less than ideal alternative.

When used in TriVector mode these speakers are best placed in the ceiling to the sides of the prime listening location, with the tweeters aimed towards the front and back of the room. You can also place the speakers to the side and slightly forward or back of the prime listening position, keeping the tweeter orientation as noted above. There's a 15 degree "window" of placement forward or back of the listening position that is acceptable. But note that any more forward or back and you'll lose the diffuse effect. Also note that, due to the low midrange frequencies coming from the woofer, if you place the speakers directly over the listening position there will be a fair amount of localizable surround sound even when the speakers are set to TriVector mode.

Figure 1  
Tweeter Dispersion Pattern

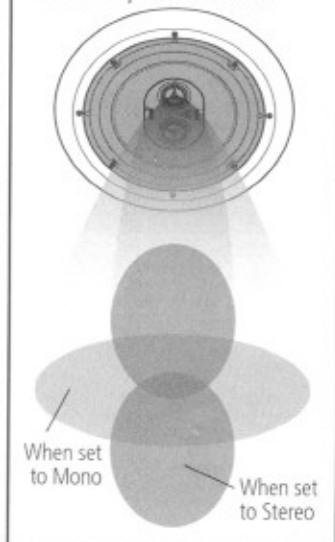

## New Construction and Retrofit Installations

**Note:** A new construction rough-in kit and back box kit are optionally available from Atlantic Technology. Please refer to the instructions included in those kits for their use. If the rough in kit has been used please go directly to Step 2 below.

### Mounting Hole Specifications:

IWTS-6 CMS: Diameter = 7-7/8 in., 205mm; Depth = 3-7/8 in., 98mm

IWTS-8 CMS: Diameter = 9-1/2 in., 247mm; Depth = 4-1/4 in., 108mm

- 1** Cut an appropriately sized opening in the ceiling material. Be sure that the ceiling material can support the weight of the speaker. Also be sure that the sides of the opening are at least 1-1/2 inches away from any beams or studs within the cavity. If it is not, the rotating clamps will be restricted in their movement and may not clamp properly.
- 2** Be sure that all foreign material in the ceiling is kept out of the speaker assembly, particularly the back of the woofer cone. (There is a cloth shield on the rear of the woofer, but please use care anyway.) If the ceiling is void of insulation it will be beneficial to the performance of the speaker to install an Atlantic Technology foam Sound Damping Kit behind and around the assembly.
- 3** **IMPORTANT:** Depending on the sound mode (mono, stereo or surround) you intend to use, certain settings must be made before installing your speaker(s).

**Jumper Settings** Find the jumper pins on the crossover board of your speaker. They are the same for both the 6 CMS and 8 CMS. For Stereo operation, install the jumper blocks as shown in Figure 2A. For Mono/TriVector operation, install the jumper blocks as shown in Figure 2B.

**Operation Settings** To set the 6 CMS for Normal (mono or stereo) operation, attach the wiring connector to the pins marked NOR on the crossover board as shown in Fig. 3A. For Trivector surround operation, attach the connector to the pins marked SUR (Fig. 3B).

To set the 8 CMS for Normal (mono or stereo) operation, set the upper selector switch located on the tweeter assembly to NOR. For TriVector surround operation, set the selector to SUR (see Fig. 4A). Use the high frequency level adjustment, also located on the tweeter assembly, to increase (+) or decrease (-) the level of high frequency sound produced by the tweeters. The settings on the 8 CMS can easily be changed after the speaker is installed (see Fig. 4B).

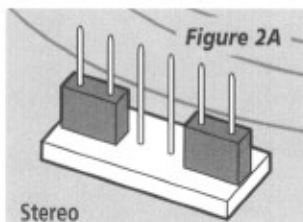

Stereo

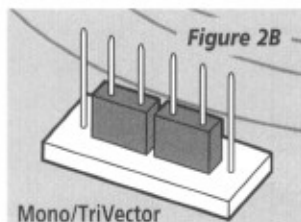

Mono/TriVector

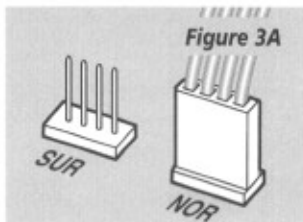

Figure 3A

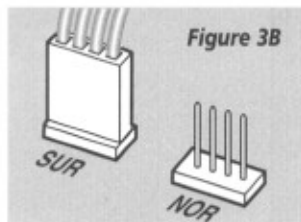

Figure 3B

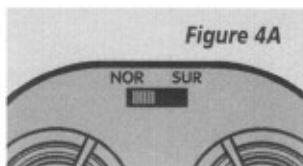

Figure 4A

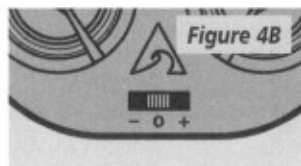

Figure 4B

- 4** Attach the previously installed audio feed wires to the appropriate speaker terminals. For Mono or TriVector operation either set of input terminals may be used. For Stereo operation one set of leads is attached to each set of input terminals. Simply remove 1/2 inch of insulation from the end of each input wire. Push down on the terminal connector and a large opening will appear in the shaft of the connector that is capable of holding up to 10 gauge wire. Insert the bare wire into the opening and release the terminal. Be sure to observe correct polarity, connecting the positive (+) leads to the red terminals and the negative (-) leads to the black terminals. Also be sure that no stray strands of wire touch across any terminals. See Figure 5.

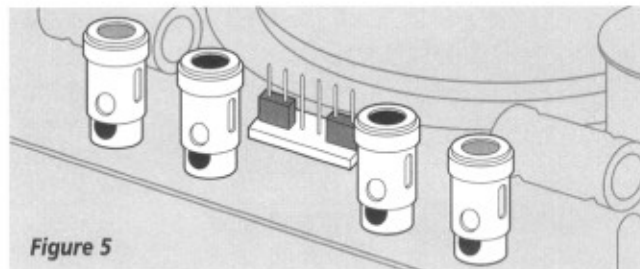

Figure 5

- 5** Check to ensure that the rotating clamps are "parked" and not sticking out over the edge of the assembly.
- 6** Push the speaker assembly straight up into the opening with the tweeters oriented as noted previously.
- 7** Tighten the mounting screws one at a time. As you tighten, the rotating clamps on the back of the assembly will turn and lower, until they contact the back of the ceiling and clamp the ceiling between themselves and the trim ring. See Figure 6.

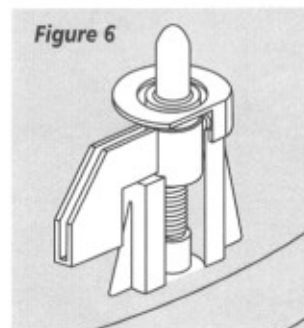
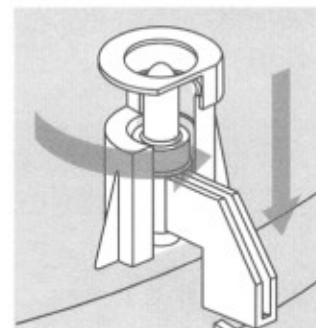

Figure 6



- 8** Snug all four mounting screws in this manner to make a firm seal with the ceiling. Be careful not to overtighten them.
- 9** Start the system and make sure the speakers are operating properly. If you have installed the 8 CMS adjust the high frequency switch (on the tweeter assembly, under the grille) to get the most natural balance of sound throughout the listening area.
- 10** Install the grille by placing it into the recess and pushing it in gently.

## Specifications

	IWTS-6 CMS	IWTS-8 CMS
Frequency Response	55 - 20kHz, +/- 3dB	45 - 20kHz, +/- 3dB
Sensitivity (1 watt/1 meter)	89dB	89dB
Impedance	2 x 8 Ω, Stereo; 1 x 4 Ω, Mono	2 x 8 Ω, Stereo; 1 x 4 Ω, Mono
Woofer type	Dual VC, Mica/Graphite loaded Polymer cone	Dual VC, Mica/Graphite loaded Polymer cone
Tweeters	2 x 3/4 inch Mylar Domes w/phase lens	2 x 1 inch silk domes w/phase lens
Weight	4.8 lbs.	5.25 lbs.

### Atlantic Technology

343 Vanderbilt Avenue Norwood, MA 02062  
(781) 762-6300 www.atlantictechnology.com

## Free Manuals Download Website

<http://myh66.com>

<http://usermanuals.us>

<http://www.somanuals.com>

<http://www.4manuals.cc>

<http://www.manual-lib.com>

<http://www.404manual.com>

<http://www.luxmanual.com>

<http://aubethermostatmanual.com>

Golf course search by state

<http://golfingnear.com>

Email search by domain

<http://emailbydomain.com>

Auto manuals search

<http://auto.somanuals.com>

TV manuals search

<http://tv.somanuals.com>