

Owner's Manual



Atomic Amplifiers

Reactor 112

Copyright 2005

Index

Introduction	1
Product Summary	1
<i>The Amplifier / Speaker</i>	1
<i>Docking System</i>	1
Getting Started	2
<i>Unpacking</i>	2
<i>Front & Rear View</i>	2
<i>Controls & Connections (Top)</i>	3
<i>Controls & Connections (Rear)</i>	4
<i>The DS-1</i>	5
<i>Template Kits</i>	5
<i>Installing a Modeler into the DS-1</i>	6
<i>Basic Set Up</i>	7
Expanding Your Rig	8
<i>Installing a Blank Template into the DS-1</i>	8
<i>Desktop Modeler in Stereo</i>	9
<i>Floorboard Style Modelers</i>	10
<i>Pro Rack Type Modelers or Preamps</i>	11
Tips & Insights	12
<i>Your Modeler's Settings:</i>	12
<i>Getting To Your Sound:</i>	12
<i>Your Modelers Left and Right Outputs:</i>	12
<i>Not Using the DS-1:</i>	12
<i>Downloading Custom Tones:</i>	13
<i>Reactors used with Analog Preamps</i>	13
<i>Using a Microphone vs. Going Direct</i>	13
<i>Using Effects Pedals etc.</i>	13
<i>Running Stereo</i>	13
Good Housekeeping	14
Reactor 112 Specifications	15
Trouble Shooting	16
Contact Atomic	17
<i>Record Your Purchase Info: *</i>	17
Obtaining Service	17
Warranty	18

Introduction

Congratulations on your purchase of an Atomic Reactor 112, a major step in bringing vacuum tube analog musicality to the digital world. The Reactor 112 is an extremely versatile musical instrument that provides a live performance platform for your modeling tools and instrument processors. The Reactor 112 is clearly different from other guitar amplifiers. What we would like to accomplish in the following pages is to bring you up to speed on exactly how and why we made it that way.

Product Summary

The Amplifier / Speaker

The Reactor 112 is made up of two systems: the main system which can stand alone is an 18 watt RMS tube audio power amplifier that is joined with a very high efficiency 12" tuned speaker system. The power amplifier employs top grade components like all polypropylene capacitors, a tube phase inverter (12AX7) plus two top-grade, EL-84 tubes to deliver full-rated power over a very wide frequency response, flat out past 20 kHz at very low distortion. It won't color or alter the tone created by a modeler, preamp, processor or effects device.

Coupled to the Reactor's amplifier section is Atomic's own, high efficiency, custom designed, 12-inch speaker. The speaker is mounted in a precisely tuned birch ply cabinet. This gives the Reactor 112 a speaker system that is wide range and smooth (no sharp peaks or ragged response). The cabinet features a unique dual flared port and a closed back. The unique design of the speaker cabinet coupled with the dynamic abilities of both the amp and speaker can give a level of performance that you would expect to hear from an amp with two to three times the power capabilities of the Reactor 112. More importantly, the way the amp and speaker system have been designed, they are able restore to the input signal, especially a digitally created model, the musical dynamics and feel that we usually expect to hear produced by a well designed analog tube amp.

Docking System

Early in the development of the Reactor 112 we decided that in addition to providing a world class sonic solution for taking digital amp modeling tools live, we would also tackle that other monster inherent to all digital technology. Having seen what happens to the value of all things digital, we designed the Reactor to be able to easily adapt to changes in technology or modeler brand popularity. This is the motivation behind the second part of the Reactor 112, The "DS-1" docking system (Patent Pending). The DS-1 acts as a universal mount for many types of modelers and preamps. The principle components in the DS-1 are the docking unit, the docking bay and the Reactor Series Template Kits.

Combined with the appropriate template kit, the DS-1 can accommodate most popular desktop modelers that are available today. As new modelers are developed, we are able to make available new template kits. Once a modeler is installed in the DS-1, all of the signal input and output as well as the power supply connections are made. No wall wart or external power is required, the Reactor automatically selects and sends the correct power / voltage to the modeler loaded DS-1. Installation and de-installation is quick and requires no tools. The DS-1 is then easily loaded into the Reactor 112. A blank template is also available for people who wish to use rack mount modelers and other choices for preamps, including the growing number of people using floor based "pedal style" amp modeling products. The Reactor's classic design will long outlive current digital technology with value, versatility, and the elegance of a classic.

Getting Started

Unpacking

If you are reading this manual you have probably already opened your Reactors shipping carton. Now would be a good time to familiarize yourself with the things that are inside the carton.

What's in the Box

Every Reactor 112 comes from the factory shipped complete with a DS-1 docking unit and the following items:

1. Owners Manual
2. Product Registration Card

Packed with the DS-1

1. One (1) AC line cable for proper usage in the country of purchase.
2. Three (3) mushroom head bumper caps
3. The wiring harness to connect a desktop style modeler into the DS-1.

Note!

Every Reactor 112 goes through extensive testing before it is boxed and shipped. If you have any questions or suspect there may be a problem relating to your Reactor 112, please E-mail Atomic at support@atomicamps.com or call the support line at 212-426-1090

Front & Rear View

A view of the Reactor 112 without the grill cloth reveals one of the many secrets to its amazing sound quality; the closed back tuned and ported speaker enclosure.

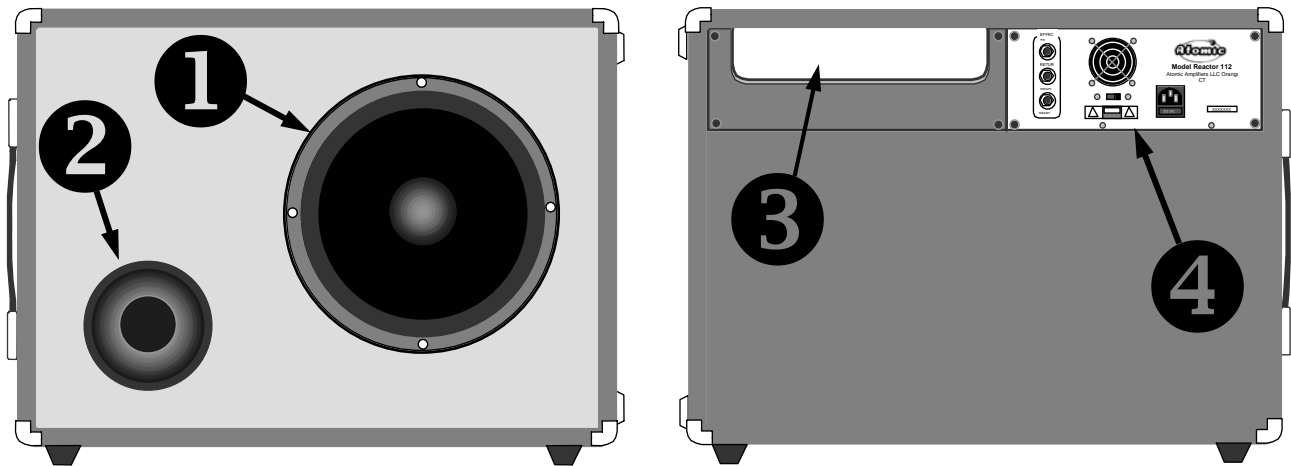

- 1 Speaker.
- 2 Dual-flared tuned port
- 3 Opening to access modeler connections for foot controllers etc.
- 4 Rear connector panel

Controls & Connections (Top)

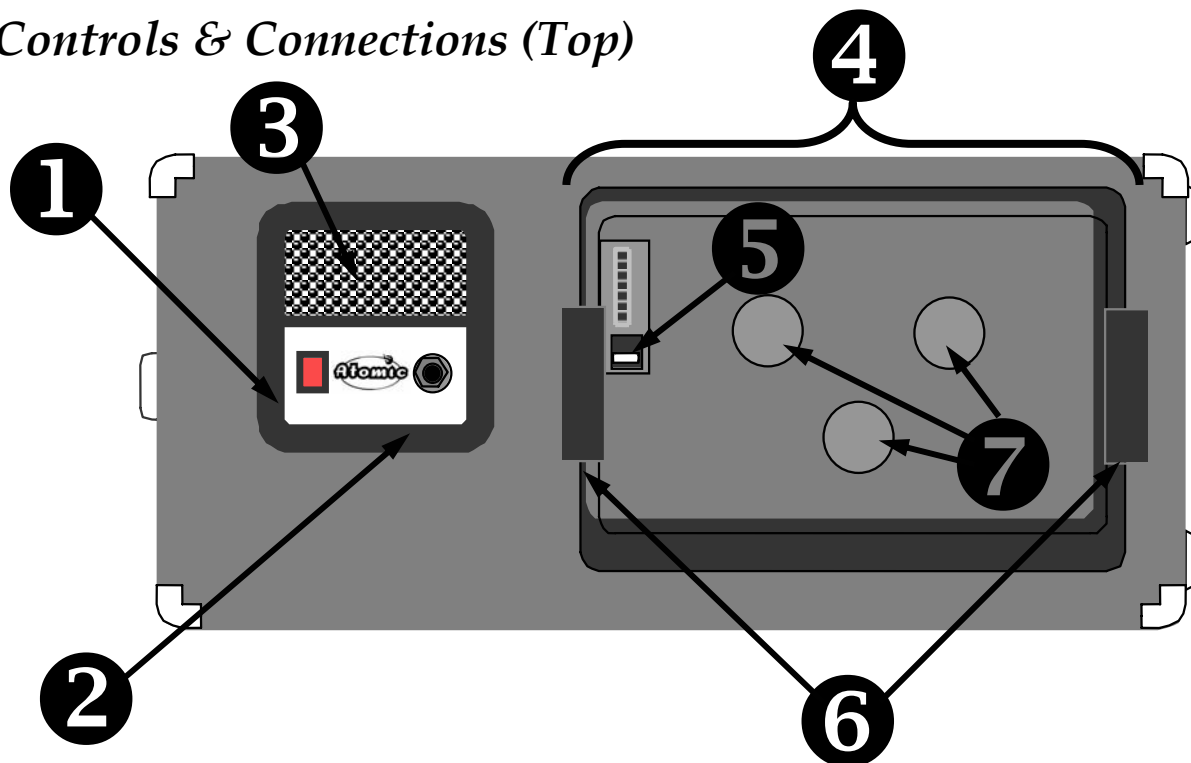

- 1 POWER:**

The power switch turns the power OFF & ON to the Reactor 112. It also acts as the master power switch for the modeler when connected and housed in the DS-1 (see page 6).
- 2 INPUT:**

This is where you plug in your instrument cable when docking a modeler inside the DS-1. **NOTE!** When using a modeler outside of the DS-1, such as a Rack-mount or floor based modeler, the instrument should be connected to the modeler per the modeler's instruction manual.
- 3 COOLING VENT:**

The cooling vent is located directly above the tubes and in conjunction with the studio quiet fan (page 4 – item “6”) does an excellent job of keeping the Reactor cool. No matter how hot the playing.
KEEP THE COOLING VENT OPEN AND FREE OF OBSTACLES!
- 4 DOCKING BAY:**

This is the mechanism in the Reactor 112 designed to house the DS-1 Docking Unit.
- 5 MULTI-PIN CONNECTOR & KILL SWITCH:**

The MULTI-PIN connector provides the audio & power to and from the dock and the Reactors electronics. The KILL SWITCH helps eliminate “POPS” and allows the DS-1 to be removed and reinserted without the user having to turn off and on the power switch on the Reactor 112.
- 6 DOCK LOCKS:**

This is where the dock “locks” into place. To release the DS-1 from the Reactor, just push the handles located on the sides of the DS-1 towards the center and pull up on the dock.
- 7 INDENTATIONS:**

Three circular indentations accommodate the thumbscrews on the DS-1 docking unit (page 6).

Controls & Connections (Rear)

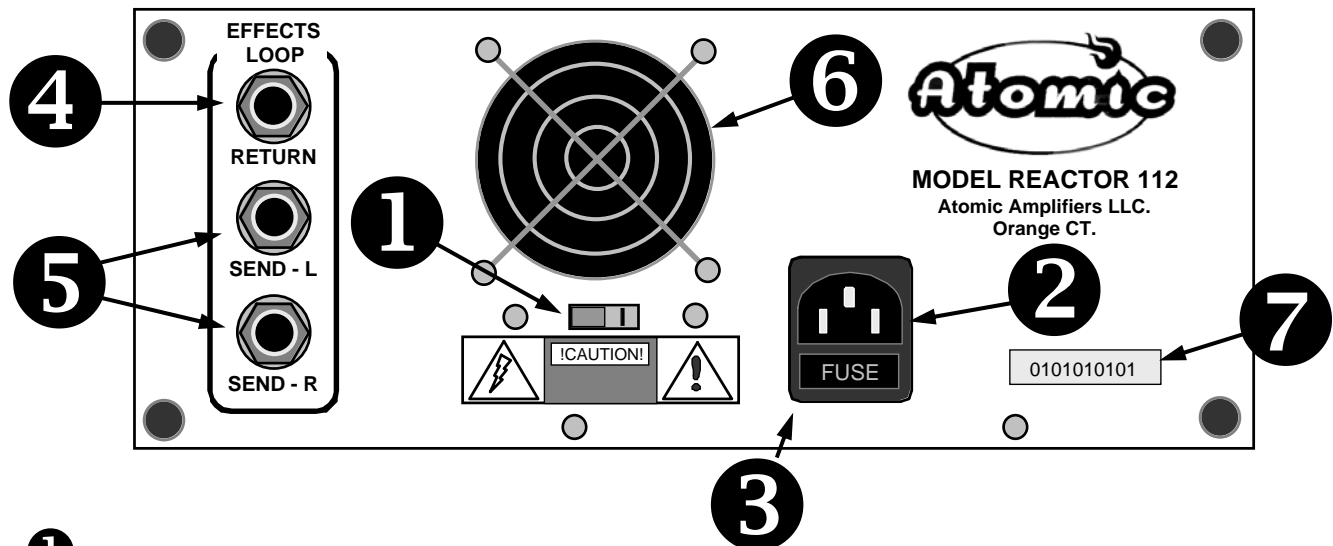

1 **VOLTAGE SELECTOR SWITCH:**

The Reactor 112 has a voltage selector switch and can be used in most countries. The switch selects between 115Volts (US use) and 240Volts (European use). **IMPORTANT!** For use in the United States the voltage selector switch should be set to the 115v setting at all times!

2 **AC LINE CONNECTOR:**

Accepts a standard grounded AC cable.

3 **FUSE HOLDER:**

The Fuse Holder houses the power fuse (see pages 15 &16)

4 **RETURN:**

The **RETURN** is unbalanced and provides an input directly to the Reactor's amplifier. Inserting a jack into the **RETURN** interrupts the signal from the left output feed from the DS-1. The **RETURN** can be used as an outboard effect return (see page 7), or as the Reactor's main input when using rack or floor style modelers and not using the DS-1 (see pages 11,12 &13).

5 **SEND - L & SEND - R**

SENDS - L and R are unbalanced and are direct sends from the Left and Right outputs of the modeler when housed in the DS-1 docking unit. **SEND - L** can provide a feed to outboard effects devices or to a sound reinforcement or recording console (see page 8). **SEND - L** can be also be used to feed signal to a second Reactor for "mono stacking" (see page 11). **SEND - R** is switched so if engaged converts a modeler housed in the DS-1 for stereo output, **SEND - R** is used to send your modelers right signal to a second Reactor for stereo operation. (See page 8 & 10). **Please note that SEND - L and SEND - R are proprietary to the DS-1 and are not operational when using modelers or preamps outside of the DS-1. Those products should be used according to their instruction manuals.**

6 **FAN:**

The Reactor 112 comes equipped with a special "studio quiet" cooling fan.

7 **SERIAL NUMBER:**

Make sure to register your Reactor either by mailing your product registration card, or by logging onto www.atomicamps.com

The DS-1

Atomic's philosophy is to afford its' customers the opportunity to choose the brand of modeler or preamp that they prefer, and thus enjoy the sonic characteristics that they demand. The DS- 1 allows Atomic Reactor Series amplifiers to act as a *platform* for select digital amp modelers and other types of related equipment. When using a modeler installed in the DS-1, all of the signal input and output as well as the power supply connections are made (see page 5). No wall wart or external power is required, the Reactor automatically selects and sends the correct power / voltage to the modeler loaded into the DS-1. Installation and de-installation requires no tools. The DS-1 is then loaded into the Reactor 112. The DS-1 design gives the user the ability to "quick swap" (you don't have to turn the Reactor on or off and wait for the tubes to come up to speed) the Dock into and out of the Reactor. With the "quick swappable" capability designed into the DS-1 you can quickly change Dock/modeler combination.

DS-1 (Top View)



DS-1 (Bottom View)



Template Kits

The installation of your modeler into a Dock requires the proper matching template kit. Currently, the following kits are available.

MODELER	PART #
LINE 6 POD	ATP2
LINE 6 POD XT	ATPXT
BEHRINGER V-AMP	ATVAMP
BEHRINGER V-AMP 2	ATVAMP
VOX TONELAB	ATTLAB
M-AUDIO BLACK BOX	ATBBOX
For rack mount & floorboard style modelers and preamps use the BLANK KIT. For more info check out pages 8, 12, 13, & 14.	ATBLANK



Template Kits are designed to adapt most popular desktop modelers into the Atomic DS-1 Docking Unit.

A template kit consist of a pre-fitted, injection molded frame and the appropriate mounting hardware to hold a modeler securely in place inside the DS-1 docking unit.

The kit also includes the proper power connecting cable for the modeler to allow the modeler to be powered by the Atomic Reactor 112's super high quality power supply! **NO WALL-WART NEEDED!**

Installing a Modeler into the DS-1

- 1 Screw the 3 thumbscrews labeled "A", "B" & "C", into the corresponding holes located on the bottom of the DS-1.

- 2 Attach the 3 rounded mushroom heads caps to the ends of the locking screws. *

*A set of mushroom heads come shipped with each Reactor 112.

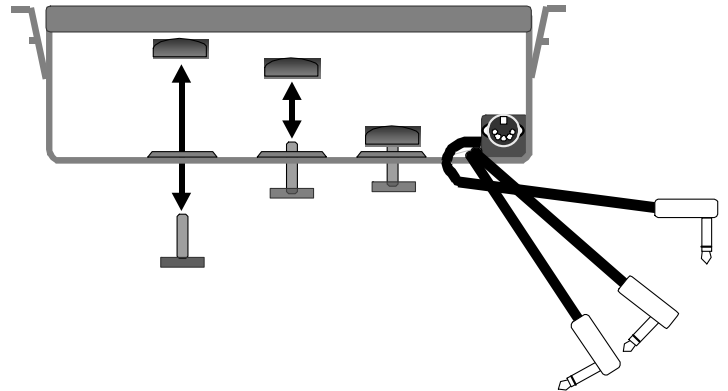

- 3 Position the proper docking template on the top of your modeler.

- 4 Insert the docking template along with the modeler into the rear of the DS-1, locating and positioning it in the notch of the template frame.

- 5 Tighten down the thumbscrews until modeler is held securely in place.

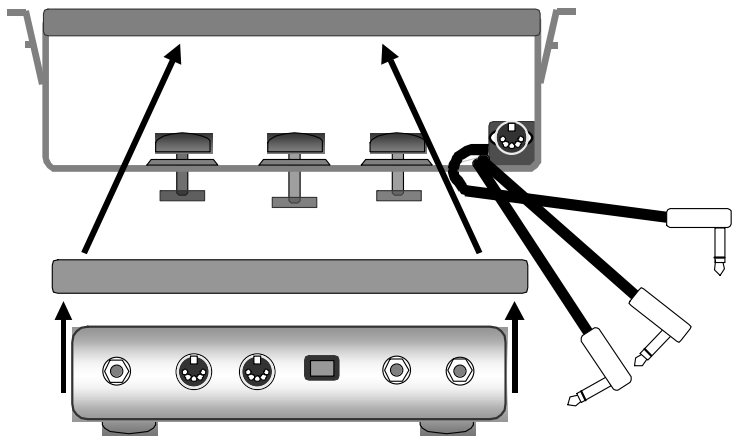

- 6 After securing modeler, connect the Input and, Left/Right output connectors. The Input cable is extra long to accommodate modelers that have their input jacks located on the front. Please note that there is plenty of room to get to foot controller connections etc.

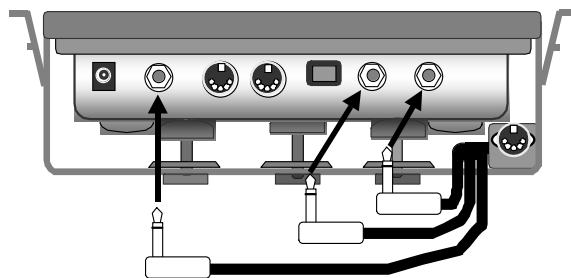

- 7 Use the power cable included with the docking template to connect between your modeler's power input and the DS-1's power output. **THERE IS NO NEED FOR AN EXTERNAL POWER SUPPLY.** The DS-1 automatically compensates for your modeler's voltage and polarity.

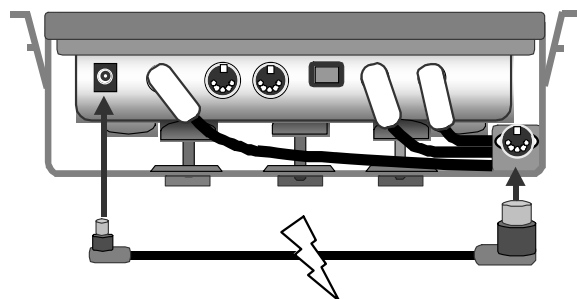

*The Right Output of the DS-1 connects the modeler directly to the Reactor's Send - R jack on the effects loop. It keeps the modeler in mono operation unless the Send R is engaged by plugging a cable into it.

Basic Set Up

- 1 After obtaining the proper template load your modeler into the DS-1 provided with your Reactor 112. (Make sure the modelers power switch is set to on.)
- 2 Load the DS-1 into the docking bay located in the top of your Reactor, making sure that the dock locks click into position. Once loaded properly the audio and power connections are made between the Reactor and the DS-1.
- 3 Plug the AC cable that comes supplied with your Reactor 112 into the AC input located on the back panel of the Reactor. **MAKE SURE THE VOLTAGE SELECTOR SWITCH IS SWITCHED TO 115V FOR USE IN THE U.S.**
- 4 Using a quality, shielded, musical instrument cable, plug your instrument into the INPUT jack found on the Reactors top panel.
- 5 It is a good idea to make sure the output levels are turned down on your modeler.
- 6 If you wish to use out board effects devices, use **SEND - L** to go to the inputs of the effects. From the outputs of your effects use **RETURN**. (for more on effects see page 9).
- 7 Turn the power switch to the ON position (it should light up). Your modeler should power up at the same time as the amp.
- 8 Bring up the levels on your modeler and switch to some of your favorite presets.

! **For best results, the modeler should be used in "direct" mode.**

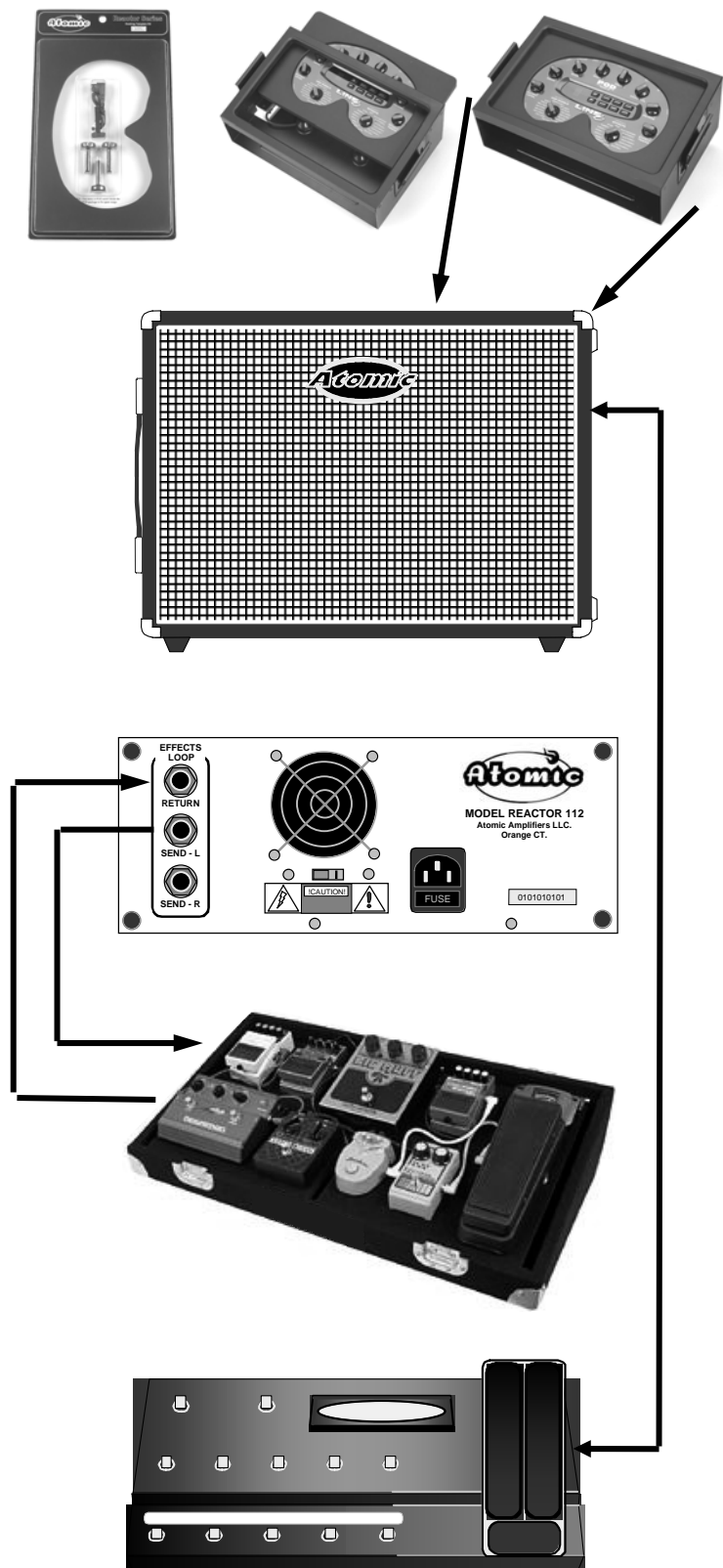

Expanding Your Rig

Installing a Blank Template into the DS-1

- 1** First locate the 8 screws attaching the template frame to the top of the DS-1. There are 4 screws that come in groups of 2 on each side. Remove these screws **(and don't lose them!)** using a properly sized Phillips-head screwdriver.

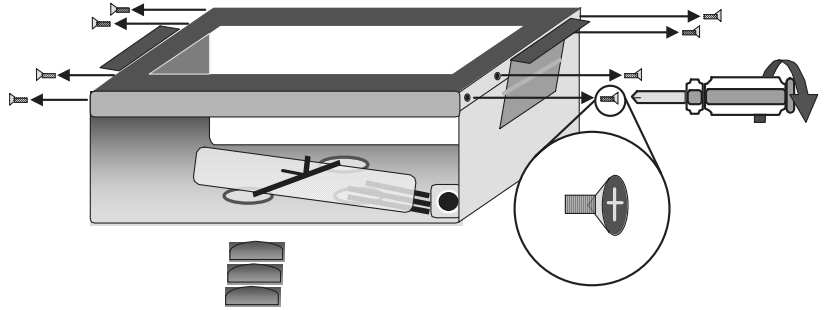

- 2** Remove the template frame of the DS-1

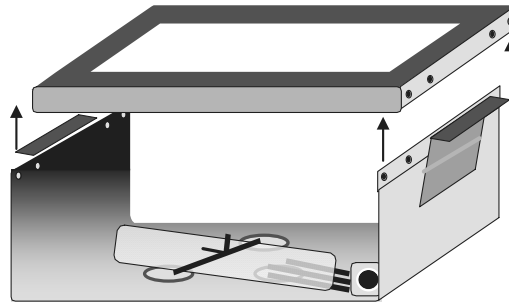

Still got the screws?

- 3** Replace the template frame with a blank template (Atomic Part # ATBLANK – purchased separately).

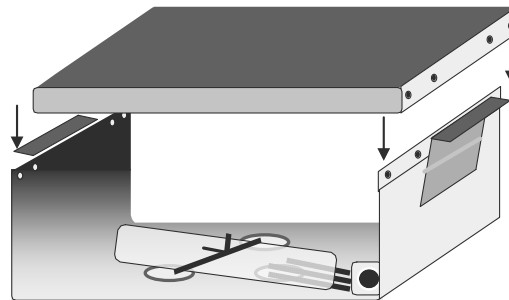

Still got the screws?

- 4** Replace the 8 screws. **(Whew!)** You can now load the DS-1 into the Reactor as usual*.

The Reactor is now ready to be used with a Pro-rack or foot controller style modeler

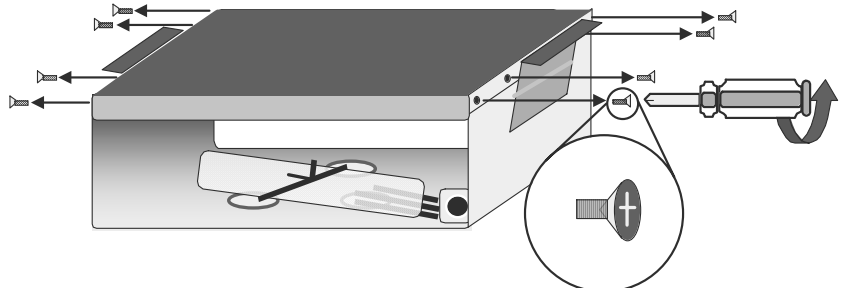

NOTE! When bypassing the DS-1, the “RETURN” input on the rear jack panel of the Reactor 112 should be used as the Reactor’s main input, (see pages 11-14). Inserting a jack into the RETURN puts the Reactor in “Direct Mode” and automatically cancels out the open audio cables from the DS-1.

Desktop Modeler in Stereo

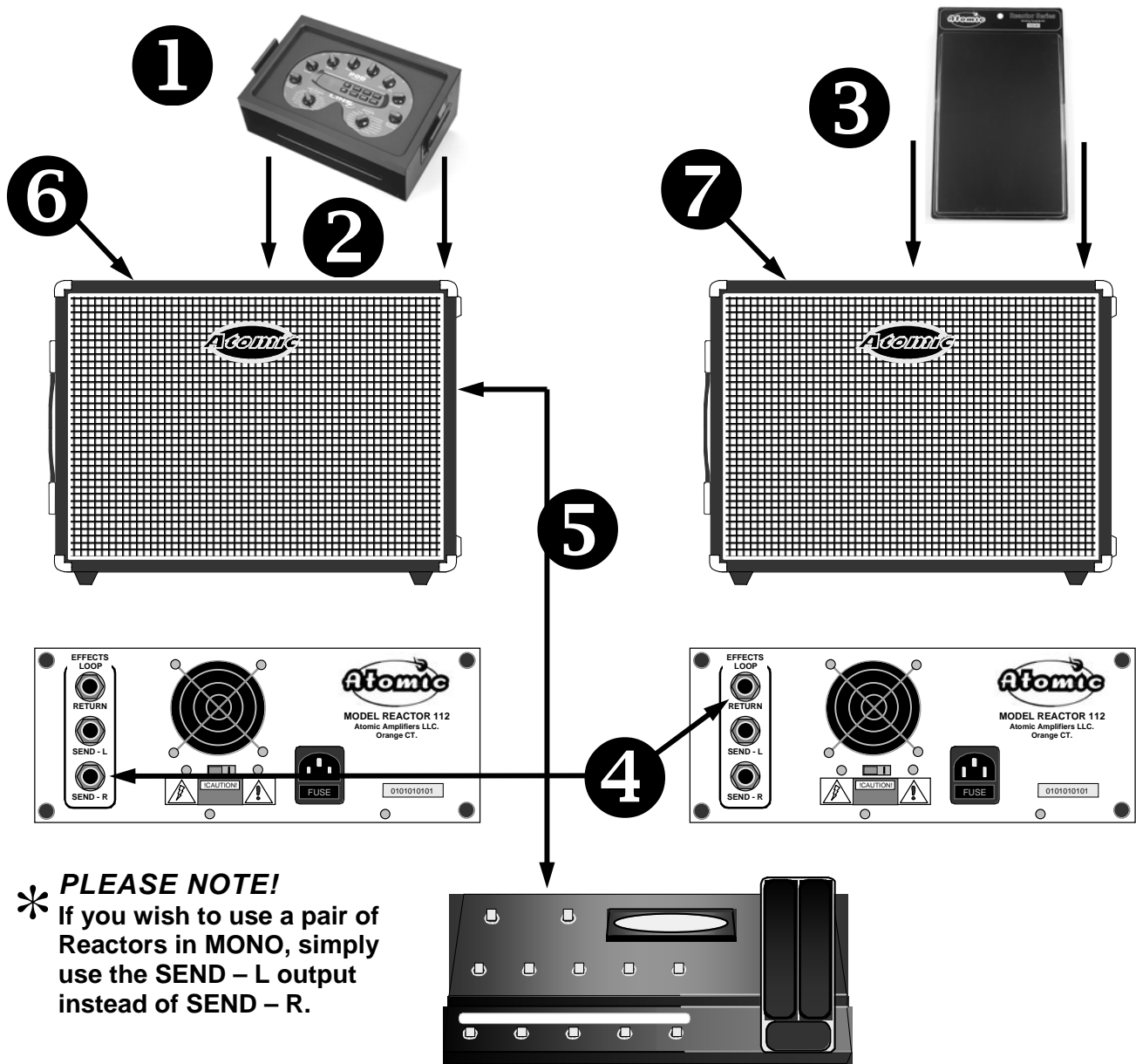

*** PLEASE NOTE!**
If you wish to use a pair of Reactors in MONO, simply use the SEND - L output instead of SEND - R.

- 1** After obtaining the proper template load your modeler into the DS-1 that comes provided with your Reactor 112 (see page 8).
- 2** Load the DS-1 into the docking bay located in the top of Reactor #1, making sure that the dock locks click into position.
- 3** Install a blank template onto the Reactor #2's DS-1. Then load the DS-1 back into the Reactor. (see page 10)
- 4** Run a standard shielded 1/4 inch cable from Reactor #1's Send R on the rear panel to the Return on Reactor #2's rear panel.
- 5** If using a foot controller with your modeler, connect it as normal using the connector access port located on the rear of the reactor.
- 6** Turn on Reactor #1s power switch (it should light up). Your modeler should power up at the same time as the amp.
- 7** Turn on Reactor #2s power switch (it should light up).
- 8** Bring up the levels on your modeler and switch to some of your favorite presets.

Floorboard Style Modelers

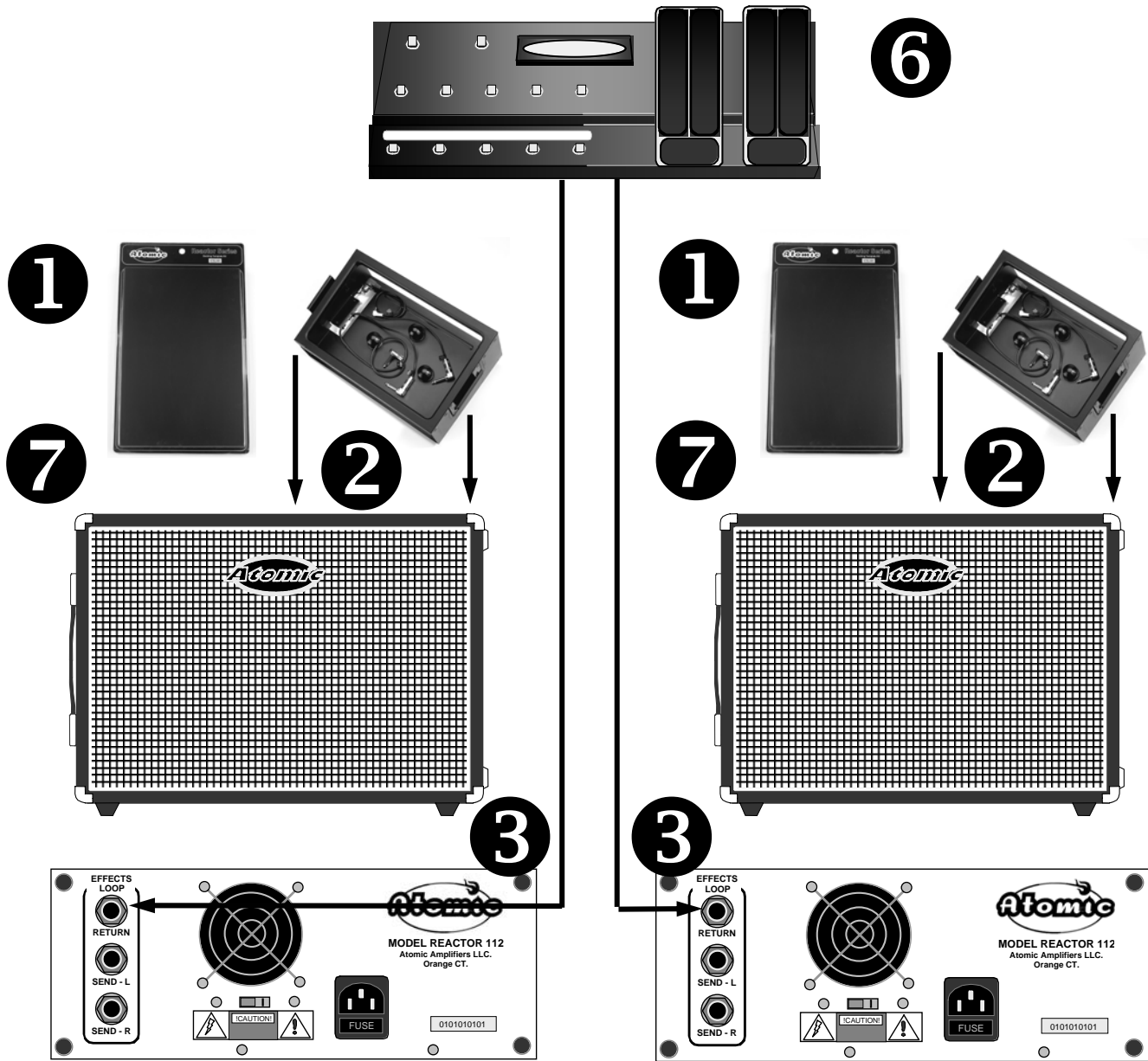

- 1** Using two Reactor 112s Install blank templates onto the DS-1 docking units. (see page 10)
- 2** Replace the DS-1's back into the docking bays located in the top of the Reactors making sure that the dock locks click into position.
- 3** Plug the Left and Right outputs of your Foot Controller style modeler or preamp into the pair of Reactor's RETURN inputs.
- 4** If using outboard effects pedals or devices with your modeler, connect them as normal per the manufacturer's instructions.
- 5** It is a good idea to make sure the output levels are turned down on your modeler.
- 6** Turn the modeler's power on.
- 7** Turn the Reactors power switches to the ON position (they should light up).
- 8** Bring up the levels on your modeler and switch to some of your favorite presets.

Pro Rack Type Modelers or Preamps

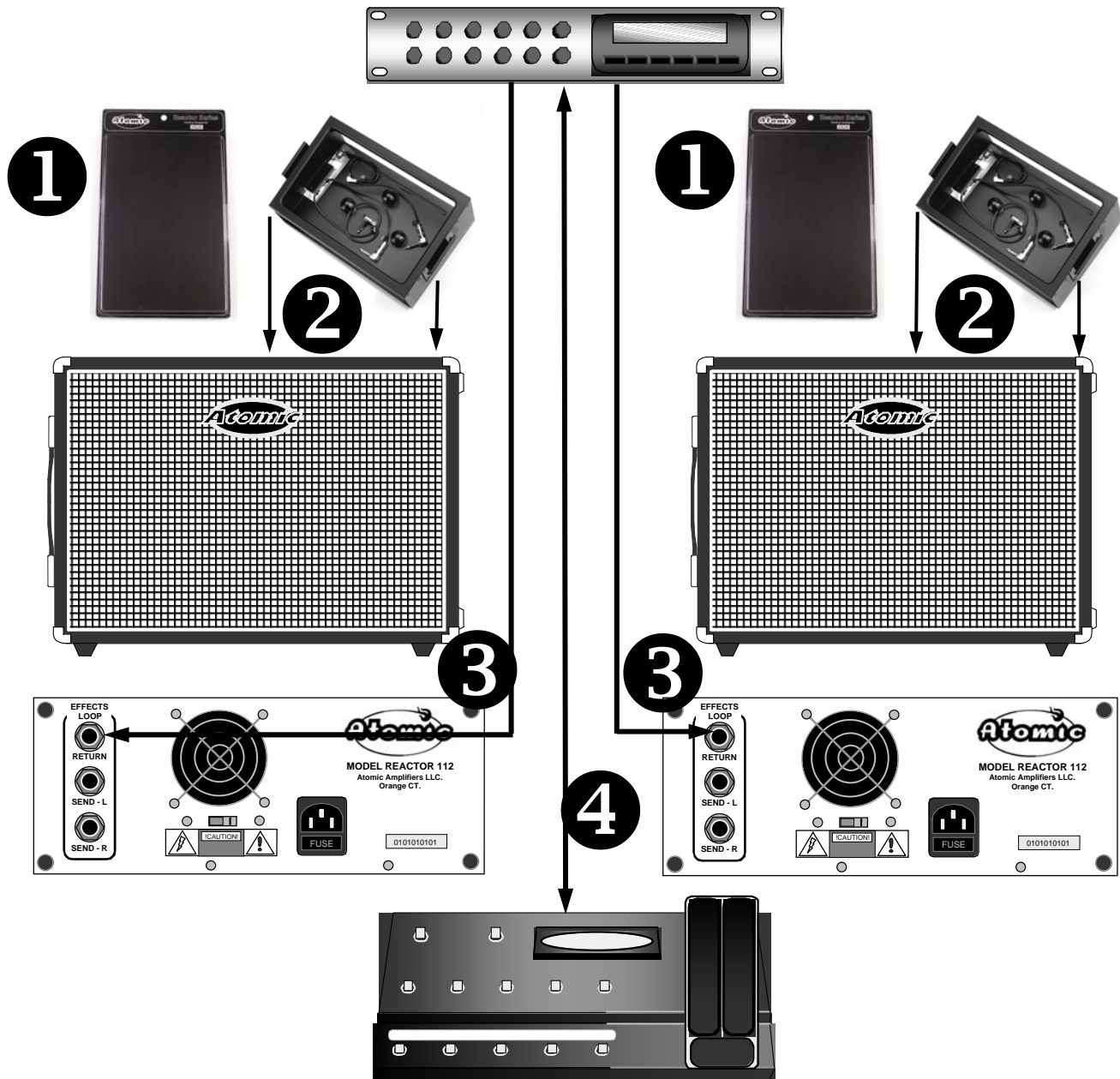

- 1** Using two Reactor 112s Install blank templates onto the DS-1 docking units. (see page 10)
- 2** Replace the DS-1's back into the docking bays located in the top of the Reactors making sure that the dock locks click into position.
- 3** Plug the Left and Right outputs of your Pro-Rack style *modeler or preamp* into the pair of Reactor's RETURN inputs.
- 4** If using outboard effects pedals or devices with your modeler, connect them as normal per the manufacturer's instructions
- 5** It is a good idea to make sure the output levels are turned down on your modeler.
- 6** If using outboard effects pedals or devices with your modeler, connect them as normal per the manufacturer's instructions.
- 7** Turn the Reactors power switches to the ON position (they should light up).
- 8** Bring up the levels on your modeler and switch to some of your favorite presets.

Tips & Insights

Your Modeler's Settings:

The Reactor 112 was designed to bring out the very best in your modeler. Atomic recommends that in order to achieve the best sounding results, modeler's should be used in their "direct" mode. To achieve the most realistic/natural amp and effect sounds, cabinet and mic simulations can stay "on" but room levels should be turned "off" or be set to 0% and mics should be positioned "on access". The bottom line is that tone is **very** subjective and you should follow your ears. There are no rules – only what sounds best to you!

Getting To Your Sound:

Many amplification and speaker systems that are transistor based use a bass roll off or a limiter in an effort to prevent nasty clipping of other undesirable artifacts (this, they call a feature!). If you have been using such a system (including some headphones), you should be delighted with the natural sonic openness you will experience with the Reactor 112. The Reactor's closed back tuned and ported speaker system can deliver a wide frequency response with extended bottom end capabilities not found in other combo amps. The benefits of the Reactor become more evident when players tune down to a "D" or other tunings. By allowing the user to not fight the amp trying to boost frequencies that aren't there the amp runs a lot more efficiently, allowing it to focus its power over the instruments entire frequency spectrum. Your modeler's tone controls come to life, and should provide you with a whole new level of control over your sound.

Your Modelers Left and Right Outputs:

Most, if not all, digital amp modelers feature a pair of left and right line outputs. The accepted standard is that the left output provides the feed for mono operation (see your modelers user manual!). Plugging a jack into the Right output automatically switches the modeler's outputs for stereo operation. The DS-1 docking station is designed to retain your modeler's standard mono and stereo operating capabilities even though the right and left outputs are connected. The modeler remains in standard mono operating mode until a jack is inserted into the Send R output on the rear jack panel of the Reactor 112. Unless a jack is inserted into the Send R output, a modeler properly loaded into the DS-1 will continue to provide full mono operation capabilities when used with the Reactor 112.

Not Using the DS-1:

If you are using a floorboard style or a "Pro" Rack style modeler don't worry! You can still experience the sonic superiority of a Reactor by simply plugging your modeler's output(s) into the "Return" inputs located on the rear jack panel of the Reactor. When plugging into the Return you are bypassing the Reactor's input (see page 2). You are also putting the DS-1 into audio by-pass mode. You can run your modeler and the rest of your outboard equipment as you normally would as per their owner's manuals.

Downloading Custom Tones:

The Reactor 112 was designed to bring out the very best in *your* modeler. That means the one you own. As the Reactor has become the industry standard for taking modeling tools live some manufacturers have expressed interest in developing presets for their modelers that are Reactor specific. Since the DS-1 and the Reactor were designed as a “platform” for different types and brands of modelers we welcome these efforts to improve your playing experience. Some times it’s great to have a jumping off point. With this in mind Atomic has gotten together with some of our industry friends and put together some of our own sound patches. So, check out the Custom Patches section on our web-site at atomicamps.com. There you will find downloadable custom Reactor tone patches for all of the most popular modelers and programmable guitar preamps.

Reactors used with Analog Preamps

Variety is the spice of life. That’s why we made the Reactor 112 the perfect platform for all kinds of guitar amp front ends. Go ahead, experiment, take that TriAxis or Kolbe GP-1 and plug its line output right into the return input on the rear panel of the Reactor you might be in for a pleasant surprise!

Using a Microphone vs. Going Direct

At Atomic we feel that this should be up to the player or engineer to decide. Running direct gets rid of stage bleed and microphone coloration, **BUT** if you mic the Reactor 112 it sounds an awful lot like you are micing whatever amp your modeler is set to. This makes the Reactor an excellent choice for recording studios.

Using Effects Pedals etc.

Many players blend stomp boxes and effects processors from various brands and vintages to shape their own unique sound and are not ready to give them up for the all in one solution offered by modelers (as convenient and tempting as it may be). The Reactor 112 works great with all outboard gear – analog, digital and otherwise! In cases where a modeler is loaded in the DS-1, use the Reactor as you would any combo amp with an effects loop to position outboard gear both before and after the preamp (modeler). The Reactor works equally well with floor based and pro rack modelers. In this instance there is no need to use the effects loop in the traditional sense since you can insert effects between the modeler and the Reactor’s power section by putting them after the modeler’s output and before entering the Reactor via the Return jack. This achieves the same result. As always, consult your effects processor’s manual for guidelines for proper operation.

Running Stereo

The recommended “norm” for stereo playback in recording and mastering studios as well as pretty much all listening environments is that the left and right speakers be placed in an equilateral triangle in conjunction with the listener’s ears. This type of listening / playing set up takes into consideration things like phase coherency, spatial imaging, and let’s not forget effects like auto-pan, stereo flanging and Ping-Pong echo. Stereo is great fun to listen to and even more fun to play through. The sonic “space” that one can create can lead to inspiration, which you just can’t hang a price tag on. So ...Unless you plan on sticking your face directly in front of one of those all in one stereo cabinets you do the math. 2 Reactors on the other hand allow you to create a TRUE stereo spread.

Good Housekeeping

Output Tube Bias

Your new REACTOR 112 has an internally mounted variable bias control. The bias control is used to set the idle current in the output tubes, properly matching amp's performance characteristics to the type of tubes used. Each different tube brand and manufacturer may require a slightly different bias setting. An amp's bias can drift over time as well as the tubes bias requirements may change with extended use. The bias should be checked periodically and when the tubes are replaced. A properly biased amp will sound great and will run reliably and safely.

Beware! Internal voltages of tube type amplifiers are lethal and capacitors are capable of storing these lethal charges. To ensure tone and safety, qualified personnel *only* should carry out biasing the amp.

Tube Replacement

The REACTOR 112 tube compliment consists in one 12AX7 used as a phase inverter (not a pre-amp) and two EL-84s for power. For continued optimum performance from your REACTOR 112, these tubes should only be replaced with tubes of the same type and specification.

The Fuse

The fuse is in the AC supply of the amplifier and will help to protect the amplifier in the event of an electrical fault or tube failure. If a fuse blows, replace it only with one of the same type and rating. (Refer to the specification page to determine the correct fuse type and rating.) NEVER use a fuse with a higher rating as this could damage the amp and present a serious safety hazard. If the fuse blows repeatedly, the amp should be taken to an authorized service center.

Always Use High Quality Shielded Cables.

The Reactor 112 loves to be fed really good signals so now might be a good time to make sure your not cheating yourself out of any sound quality. Some cable companies are all hype but some can provide an amazing improvement. Take some time and "listen to your cables" a few bucks on a good instrument cable can go a long way toward getting the sound you are looking for.

Reactor 112 Specifications

POWER REQUIREMENTS: | **US:** 115V AC, 50/60 Hz 45W
| **EU:** 240V AC, 50 Hz 45W

AMPLIFIER POWER OUTPUT: 18W into 8 ohms at 3% THD

POWER AMP INPUT SENSITIVITY | 175 mv (-13db) at 1000 Hz
(RETURN): | for 18watts output

POWER AMP INPUT IMPEDANCE: 56 K ohm

TUBES: | Two EL84 tubes (Power Tubes)
| One 12AX7A tube (Phase Inverter)

FUSE: | 2A 250V at 115V setting
| 1A 250V at 240V setting

SPEAKER: | One 12", 8 ohm 150 watt
| Custom designed speaker

DIMENSIONS: | **Height:** 19.25 in (48.9 cm)
| **Width:** 26.00 in (66.0 cm)
| **Depth:** 11.00 in (27.9 cm)

Unit Weight 42.50 lbs. (19.3 kg)

WARNING:



**TO PREVENT FIRE OR SHOCK HAZARD,
DO NOT EXPOSE THIS UNIT TO RAIN OR
MOISTURE.**

**NO USER SERVICABLE PARTS INSIDE, REFER
SERVICING TO QUALIFIED PERSONNEL ONLY.
SERVICE BY PERSONS OTHER THAN ATOMIC
AUTHORIZED SERVICE TECHNICIANS MAY
VOID WARRANTY.**

THIS UNIT MUST BE EARTH GROUNDED.

Trouble Shooting

Reactor does not power up.

- 1) Is the power cord properly plugged into an electrical outlet?
- 2) Is there power at the outlet?
- 3) Is the power cord firmly inserted into the AC input socket on the rear panel?
- 4) Is the fuse blown?

The Reactor powers up but the modeler does not.

- 1) Is the Dock power cord the correct match to the modeler?
- 2) Are the connectors on the ends of the power cable properly connected to the Dock and modeler power input?
- 3) Is the modeler power switch in the "ON" position?

The Reactor and the modeler power up but no sound.

- 1) Is the output level control on the modeler turned up?
- 2) Is the guitar cable defective?
- 3) Are the Dock input and two output cables properly connected to the modeler?
- 4) Has a quarter inch phone plug been left plugged into the Return jack?
- 5) Is the Dock properly inserted into the Reactor? See warning on Dock-Lock handles.

If none of the above checks have found the problem,

The next step is to narrow down the possibilities by determining whether the malfunction is in the Reactor amp/speaker system or in the Docking System. You can do this by plugging your instrument into The Return Jack, if the instrument can be heard it would indicate that the problem is with the modeler, the modeler installation, the Dock insertion or a defective Dock.

If after checking all of the above your Reactor 112 is still not performing correctly, consult your authorized Atomic Service Center or call the Atomic Amplifier support line

(See Obtaining Service next page)

Contact Atomic

Atomic Amplifiers LLC
476 Grace Trail
Orange, CT 06477
(Phone) 212.426.1090
(E-mail) support@atomicamps.com
(Web) www.atomicamps.com

Record Your Purchase Info: * **Atomic Amplifiers Reactor 112**

Serial Number: _____

Date Purchased: _____ / _____ / _____

Purchased From: _____

Receipt Number: _____

***Make sure that you fill out and mail-in your product registration card. Doing so will create a record of your purchase that will be available in case your Reactor is lost or stolen. You can also register on-line at atomicamps.com**

Obtaining Service

How do go about getting my amp to be repaired?

If your amplifier should require service, you have two options: The first option is to take it to an Authorized Service Center in your area. A list of service centers is available on the ATOMIC AMPLIFIERS website or by contacting our CUSTOMER SERVICE DEPARTMENT. Your second option is to send the unit back to our factory service center for repair. You should first contact us for a RETURN AUTHORIZATION NUMBER and shipping instructions.

If I decide to have my amplifier repaired, do I have to pay for it?

If you haven't already, now would be a good time to familiarize yourself with the WARRANTY that was included with your amp. Within it you will find all the information in regards to what is covered, how long it is covered, and what is required by the purchaser in order to obtain Warranty Service.

Warranty

Atomic Amplifiers warrants to the original purchaser that this product (exclusive of speakers and tubes) will be free of defects in material and workmanship for a period of 5 years from the original date of purchase. Atomic Amplifiers warrants to the original purchaser of this product that the speakers will be free of defects in material and workmanship for a period of 2 years (tubes for a period of ninety (90) days), from the original date of purchase by the original purchaser; provided however, it is understood that the speaker warranty will be subject to the inspection of any speakers by Atomic Amplifiers, Atomic Amplifiers Field Service Center. These warranties are subject to the conditions, exclusions, and limitations hereinafter set forth.

This limited warranty is transferable and is valid only when accompanied by a copy of the original sales receipt with legible purchase date, purchase price, and product is purchased from an authorized dealer in the United States or Canada and must be returned to the same for any warranty services required). All exported products are subject to warranty and services to be specified and provided by the authorized distribution for each country. Excluded from this warranty are defects caused by wear and tear, accident, misuse, neglect, failure to follow all operating instructions (including the OVERPOWERING of speakers), alterations and modifications, or act of nature. Such determinations will be made by Atomic Amplifiers. This limited warranty is also void if:

- 1) The original retail purchase is not made from an Authorized ATOMIC AMPLIFIERS dealer
- 2) Any repairs, alterations, or modifications are performed by other than Atomic Amplifiers, or an Atomic Amplifiers Authorized Service Center.
- 3) The original serial number affixed to the product is altered, defaced, or removed.

All parts costs for repairs covered under this limited warranty will be borne by Atomic Amplifiers so long as the repairs have been requested within the applicable warranty periods described above. It is understood that all repair charges and costs incurred by Atomic Amplifiers for all periods following the applicable warranty period will be borne and paid for by the purchaser. All labor costs incurred by Atomic Amplifiers for repairs covered under this limited warranty will be borne and paid for by Atomic Amplifiers within the applicable warranty period according to rate schedules established by Atomic Amplifiers. All labor costs and expenses above these rates will not be the responsibility of Atomic Amplifiers. Atomic Amplifiers, or an Atomic Amplifiers Authorized Service Center MUST do all warranty services. Transportation charges involved in warranty services are the sole responsibility of the purchaser.

A copy of the original sales receipt must accompany all products being presented to an Atomic Amplifiers Authorized Service Center for warranty service. All products being returned to Atomic Amplifiers for warranty service must be accompanied by a copy of the original sales receipt, a detailed description as to needed repairs, and an Atomic Amplifiers Return Authorization. Atomic Amplifiers reserves the right to repair or replace this piece of equipment at their option but it is understood that repair or replacement as provided under this limited warranty is the sole and exclusive remedy to the purchaser for defective or non-conforming products.

Atomic Amplifiers will not be held liable for any incidental consequential, special, punitive, or exemplary damages resulting from any defect or failure of this product other than the repair of the Atomic Amplifiers product subject to the terms of this limited warranty. Any product repaired or replaced under this limited warranty will, itself, be warranted only for the remainder of the limited warranty period of the original product being repaired or replaced. Products used for dealer rental purposes shall be warranted from the date of the original invoice to dealer and if sold will be warranted only for the remainder of the limited warranty period of the original product.

This warranty gives you specific legal rights, and you may have other rights which vary from state to state, and province to province, and to the extent required by law, any limited warranty shall be limited to the duration of this limited written warranty. **OTHER THAN AS STATED ABOVE, ATOMIC AMPLIFIERS MAKES NO WARRANTIES EITHER WRITTEN, EXPRESSED, OR IMPLIED WITH RESPECT TO THE PRODUCT. THIS WARRANTY IS EXCLUSIVE, AND ATOMIC AMPLIFIERS MAKES NO OTHER WARRANTY, EXPRESSED OR IMPLIED, INCLUDING IMPLIED WARRANTIES OR MERCHANTABILITY OR FITNESS FOR ANY PARTICULAR PURPOSE, ALL OF WHICH WARRANTIES ARE HEREBY BEING DISCLAIMED.**

Free Manuals Download Website

<http://myh66.com>

<http://usermanuals.us>

<http://www.somanuals.com>

<http://www.4manuals.cc>

<http://www.manual-lib.com>

<http://www.404manual.com>

<http://www.luxmanual.com>

<http://aubethermostatmanual.com>

Golf course search by state

<http://golfingnear.com>

Email search by domain

<http://emailbydomain.com>

Auto manuals search

<http://auto.somanuals.com>

TV manuals search

<http://tv.somanuals.com>