



## AC6CD

### 6.5" 2-Way In-Ceiling Dual Mono Speaker

*Congratulations on your purchase of the AudioSource AC6CD In-Ceiling Speaker System. This product is designed to reproduce both channels of the audio portion of your home entertainment environment as a mono signal with accuracy and detail that will satisfy the most discriminating listener.*

*Please read this Installation Manual to ensure the proper installation and performance of your AC6CD speaker.*

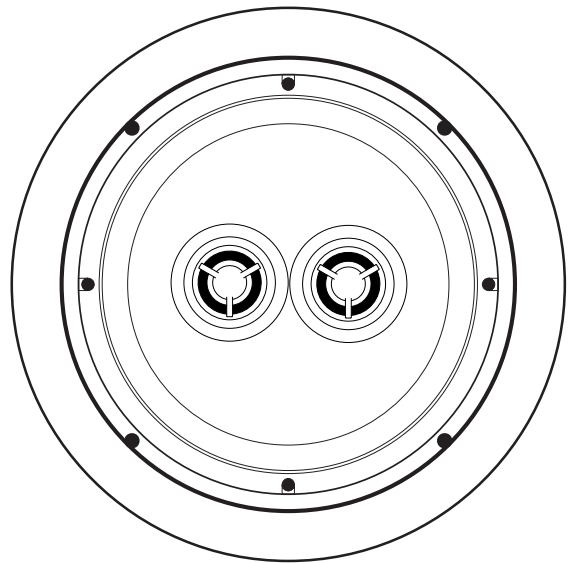

AC6CD

### Preparing for your Installation

Gather the necessary tools for your installation.

You will need the following tools:

- 1) A Keyhole or Drywall Saw
- 2) A Phillips Screwdriver
- 3) Masking Tape
- 4) A Pencil
- 5) A Bubble or Laser Level
- 6) A Tape Measure
- 7) A Stud Finder (recommended)
- 8) Your AC6CD speaker

### Placement

Plan your speaker placement carefully. Make certain that electrical, plumbing and any other services will not interfere within the ceiling where you plan to place your speakers. The AC6CD speaker can be mounted in the walls or in the ceiling, but are typically used in ceilings. The speaker should be located so that it provides even coverage at your listening position. Caution should be taken not to place the speaker less than 1 foot from a bounding surface, such as a wall or corner to prevent uneven reflections of the audio signal. (See Fig. 1)

### Existing Construction

In most modern buildings the ceiling joists are positioned on 16" centers, providing a space between the joists of approximately  $14\frac{3}{8}$ ". The AC6CD speaker requires a mounting hole 7" in diameter. Additionally, you should allow an extra  $\frac{3}{4}$ " clearance in all directions behind the ceiling surface to allow room for the doglegs that retain the frame to the ceiling surface to swing into position.

Use a stud finder to locate the joists behind the ceiling surface. Also, you should now check for obstructions like cross bracing in front of and behind the desired speaker location.

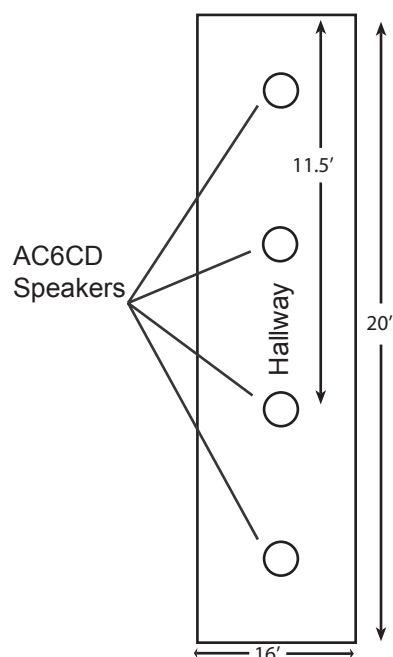

Figure 1

After selection of the mounting location, mark the hole to be cut out. A template is provided in the speaker box. Locate and align the template, then mark with pencil on the ceiling surface. If you are unsure whether there are obstructions behind the ceiling surface where the speaker is to be mounted cut a small hole in the center of your marked mounting location. Holding your drywall saw at a 45 degree angle (see Fig. 2) cut a square hole that you can use to locate any obstructions, should they exist.



ROOM  
Figure 2

The 45 degree wedge shape of the removed surfacing material will make replacement, if necessary, a much easier task and yield a better finish when patching the work.

Once it has been determined that there are no obstructions cut the hole to mount the speaker using the drywall saw at a 90 degree angle to the ceiling surface. Cover the raw edges of the wallboard with masking tape (see Fig. 3). This will prevent the back pressure of the speaker from blowing loose gypsum dust out and on to the painted ceiling surface after installation. Do not allow the tape to extend more than 1/4" beyond the edge of the hole into the room. The frame of the AC6CD will cover and hide the tape.

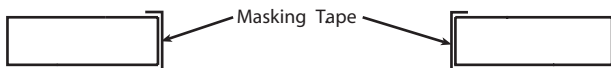

ROOM  
Figure 3

Next you will want to run your speaker wire to your speaker locations. A *UL rated CL3* speaker wire is recommended when running wire inside your walls. For proper wire gauge see page four.

When running your speaker wire you should avoid having the speaker wire run parallel to the 110V power lines to avoid picking up hum and interference from the power service. If the speaker wire needs to cross a 110V power line at a right angle this is acceptable and should not create a problem.

If you are uncomfortable with running the speaker wire yourself in existing construction, it is recommended that you retain a qualified custom home installation specialist or electrician.

## Installing the Speakers

**Installation Tip!** To further enhance the performance of your AC6CD speaker, the ceiling joist cavity where you plan to place your speaker can be stuffed with a generous quantity of fiberglass insulation. If uninsulated, stuff the area in front of and behind the speaker opening with 6" thick insulation to a depth of approximately 2 feet beginning 1 foot in front of and 1 foot behind the speaker opening. If the insulation is foil or paper backed, face the backing away from the AC6CD speaker. The addition of this insulation will help to prevent the unwanted transfer

of sound into the otherwise large and resonant cavity of the uninsulated ceiling.

It is now time to connect the speaker wire to the AC6CD. Your speaker wire is usually coded to identify each conductor as either positive or negative. This can be by color coding, or one conductor may have a printed marking or at least a rib along one edge that you will not find on the other. Identify which type of polarity coding that your wire is using. You must carefully observe that the positive terminal of the speaker output on your amplifier is connected to the positive terminal of the AC6CD speaker. Likewise, the negative terminal of the amplifier's speaker output should be connected to the negative terminal of the AC6CD speaker.

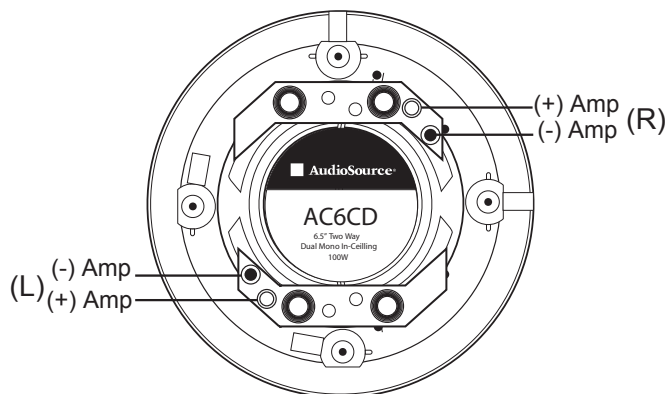

Next make sure that the doglegs are positioned inside the frame of the speaker.

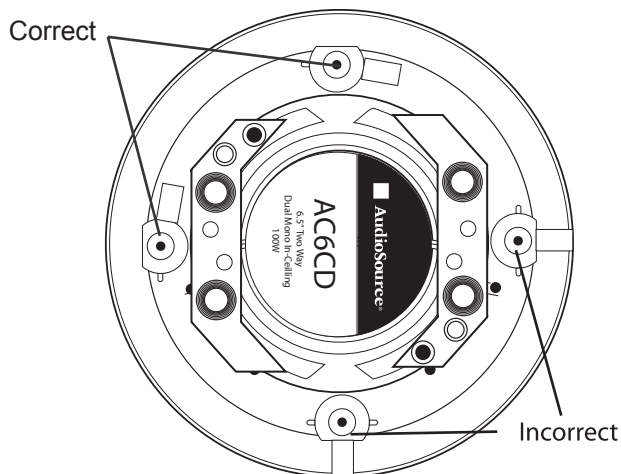

With the grill removed, place the speaker in the ceiling opening. Make sure that the speaker wire is not hanging against the speaker where it can vibrate and rattle as the speaker reproduces your music.

Next, one at a time, turn each of the four screws that operate the doglegs counter clockwise a few turns until you feel the dogleg is loose from its resting position. Now turn the screw clockwise until you feel the dogleg

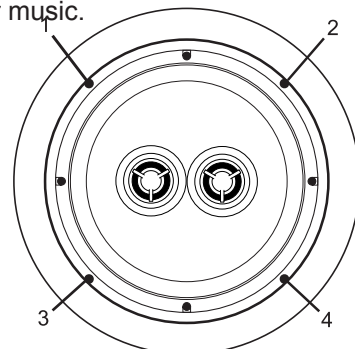

Tighten all four of the mounting screws in the same manner until the speaker is properly aligned and held tight to the wall surface. *Caution: Do not over tighten!*

## Painting the Speaker

A paint shield is included in each AC6CD speaker package. Place the paint shield inside the frame to protect the speaker. You can now safely paint the speaker's frame to match your wall surface if you desire.

When painting the grill caution should be taken to ensure that paint does not clog or congest the perforated openings in the grill. This would prevent proper operation of the grill by restricting the airflow from the individual drivers in the speaker.

## AC6CD Operation

The AC6CD speaker is designed for use where the user desires to have sound available in an area but does not need stereo imaging. This may be because of limited space, such as a bathroom or dressing area, or a long hallway where even distribution of sound is desired but stereo imaging is impractical.

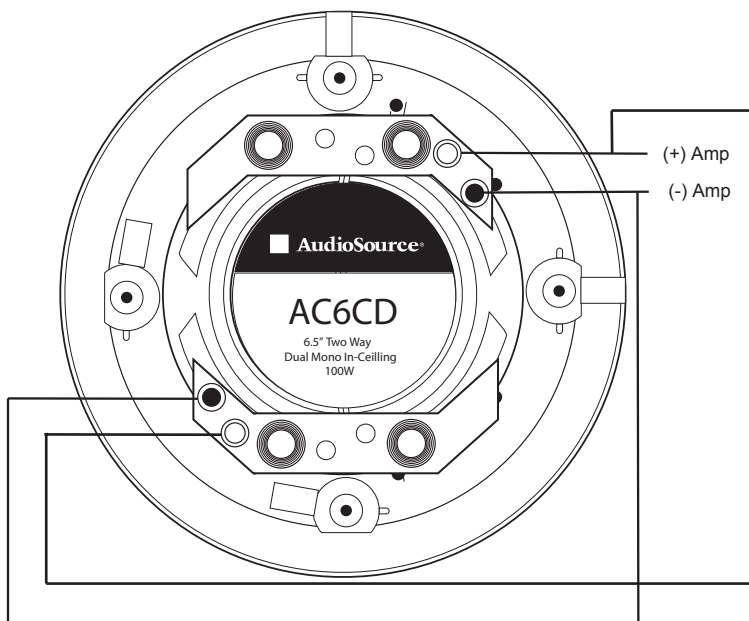

Figure 4

The AC6CD uses a dual voice coil woofer and dual tweeters. The speaker has separate terminals to allow each channel of a stereo amplifier to be connected to the one speaker.

The AC6CD can also be operated by a single channel from an amplifier and used just like any conventional in-ceiling or in-wall speaker. In this configuration you should wire the speaker terminals in parallel (fig. 4).

## Removing the AC6CD Speaker

Should it ever become necessary to remove the AC6CD speaker from the ceiling, simply remove the grill and turn the four mounting screws counter-clockwise until you feel the doglegs lock out of position in their resting flange. The speaker should easily come out of the wall for service or replacement.

## Recommended Speaker Wire Gauges

The resistance of the speaker wire in your installation can cause your speakers to perform at less than their optimum quality level. Excess resistance caused by using an undersized speaker wire can result in loss of detail and definition in the bass region of your audio program, as well as, a loss of dynamic range. Over extremely long wire runs you may even experience a loss of high frequency amplitude in the audio signal.

To prevent this effect in your installation we have recommended speaker wire gauges that should not exceed 0.5 ohms resistance over the recommended length of wire run.

For the AC6CD speakers we suggest the following minimum speaker wire gauge be used:

- 50' or less - 16 Gauge 4-Cond. CL3**
- 50' - 150' - 12 Gauge 4-Cond. CL3**
- 150' - 200' - 10 Gauge 4-Cond. CL3**

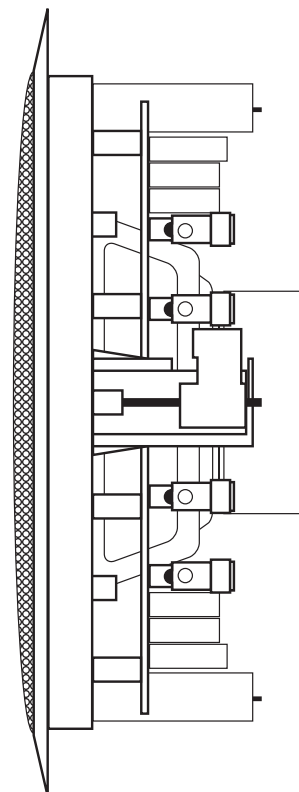

# AC6CD Specifications

<b>Dual Voice Coil Woofer</b>	<b>6.5" Poly Cone with Butyl Rubber Surround</b>
<b>Tweeter</b>	<b>Dual 19mm Ferro-Fluid cooled tweeters</b>
<b>Frequency Response</b>	<b>45Hz to 20kHz +/- 2.5dB</b>
<b>Impedance</b>	<b>8 ohm</b>
<b>Sensitivity</b>	<b>88 dB</b>
<b>Power Capacity</b>	<b>100 Watts Peak Power</b>
<b>Outer Dimension</b>	<b>9" (229mm) diameter</b>
<b>Cut Out Dimension</b>	<b>7 13/16" (198mm) diameter</b>
<b>Mounting depth</b>	<b>2.9" (73mm)</b>

---

## Two Year Limited Warranty

AudioSource, a division of Peak Audio Group, warrants this product against defects in materials and workmanship for a limited period of time. For a period of two (2) years from date of original purchase, we will repair or replace the product, at our option, without charge for parts. Customer must pay for all labor charges associated with the removal and re-installation of speakers for the limited period and all parts and labor charges after the limited warranty period expires. The limited warranty period for factory refurbished products expires after ninety (90) days from date of original purchase. This limited warranty applies only to purchases from authorized AudioSource Retailers or Distributors. This limited warranty is extended only to the original purchaser and is valid only to consumers in the United States.

Consumers are required to provide a copy of the original sales invoice from an authorized AudioSource Retailer or Distributor when making a claim against this limited warranty. This limited warranty only covers failures due to defects in materials or workmanship that occur during normal use. It does not cover failures resulting from accident, fire, flood, misuse, abuse, neglect, mishandling, misapplication, alteration, faulty installation, modification, service by anyone other than AudioSource, or damage that is attributable to Acts of God. It does not cover costs of transportation to AudioSource or damage in transit. The customer should return their defective product, freight prepaid and insured, to AudioSource only after receiving a Return Authorization.

Repair or replacement under the terms of this warranty does not extend the term of this warranty. Should a product prove to be defective in workmanship or material, the consumer's sole remedies will be repair or replacement as provided under the terms of this warranty. If the defective product is discontinued AudioSource may replace the product with an equivalent or superior product at its option. Any cost of re-installation or repair of wall or ceiling surface is the sole responsibility of the customer and that cost shall not be the responsibility of AudioSource. Under no circumstances shall AudioSource be liable for loss or damage, direct, consequential or incidental, arising out of the use of or inability to use the product. There are no express warranties other than described above.



13970 SW 72nd Avenue ■ Portland, Oregon 97223  
503.914.4688 ■ Fax: 503.746.5224 ■ Support: 877.715.5439  
[www.audiosource.net](http://www.audiosource.net) ■ [support@audiosource.net](mailto:support@audiosource.net)

## Free Manuals Download Website

<http://myh66.com>

<http://usermanuals.us>

<http://www.somanuals.com>

<http://www.4manuals.cc>

<http://www.manual-lib.com>

<http://www.404manual.com>

<http://www.luxmanual.com>

<http://aubethermostatmanual.com>

Golf course search by state

<http://golfingnear.com>

Email search by domain

<http://emailbydomain.com>

Auto manuals search

<http://auto.somanuals.com>

TV manuals search

<http://tv.somanuals.com>