

INTRODUCTION

Thank you for purchasing the AudioSource **EQ NINE** Graphic Equalizer/Spectrum Analyzer. It is a fully electronic unit with soft-touch controls, that will enable you to automatically adjust each of the twelve bands per channel, while the results are instantly displayed on the Spectrum Analyzer. The **EQ NINE** will help you to maximize the potential of your audio system while compensating for the acoustical problems caused by room size and shape, furnishings and other sound reflecting surfaces.

You can store your favorite equalization curves in the four separate memories, and recall them at the push of a button. Tape-to-tape dubbing and tape equalization are a breeze with the **EQ NINE**.

By spending a few minutes to read the operating instructions carefully, you will have years of enhanced listening pleasure.

INSTALLATION

PRECAUTIONS - Please follow these simple steps when operating the **EQ NINE** or any electrical device.

POWER PLUG - Always grasp the plug when removing it from a socket. Never pull on the wires. Never remove or install the plug with wet hands, or electrical shock could occur. If you are not planning to use the unit for an extended length of time, it is wise to unplug it.

REMOVAL OF CASE - There are no user servicable parts inside the **EQ NINE**, so you should never remove the case of the unit, as risk of shock exists. Refer all servicing to qualified service personnel.

INSTALLATION PRECAUTIONS - Avoid installing your **EQ NINE**, or any electrical device, in areas exposed to direct sunlight, near heat radiating appliances, exposed to

moisture or humidity, exposed to dust and dirt, in areas with poor ventilation, directly on top of power amplifiers and other heat producing components, or on surfaces which are unstable or prone to vibrations.

CLEANING - Wipe the faceplate and case of the **EQ NINE** periodically with a soft cloth. Avoid using any thinners or volatile liquids to clean the **EQ NINE**.

INPUT-OUTPUT JACKS AND CONNECTIONS

Before connecting the **EQ NINE** to your system, all units should be turned "off".

At the rear of your **EQ NINE**, you will find six sets of jacks which require cables with RCA plugs: LINE, TAPE 1, & TAPE 2. TAPE 1 and TAPE 2 allow you to run two different tape units through the equalizer. LINE supplies the link to your receiver or integrated amplifier. Connect the LINE-IN of the equalizer to TAPE-RECORD on your amplifier. Connect the LINE-OUT on the equalizer to TAPE-IN (or MONITOR) on your amplifier.

To connect your tape deck to the equalizer: TAPE 1-IN from the equalizer goes to TAPE-OUT (PLAY) on your tape deck. And TAPE 1-OUT from the equalizer goes to TAPE-IN (REC) on your tape deck. Make the same connections in TAPE 2 to the second tape deck if you have one.

ELECTRONIC CONTROLS

BEEP: Pressing the button causes beep.

① Power

Press to turn the equalizer ON. Press again to turn the power OFF.

② Line/Tape Source Selector

This switch determines which component will run through the equalizer. To listen to sound or record from a source connected to the LINE terminals jacks press the Line/Tape switch (indicator lights should be off). To listen to sound or record from a tape deck connected to the TAPE jacks, press the Line/Tape switch and the indicator will light up.

③ Tape 1-2 / 2-1

Pressing this switch shifts your listening between tape decks that are plugged into the Tape 1 or Tape 2 jacks. The indicator light turns on when Tape 2 is selected or when dubbing from Tape 2 to Tape 1.

When you record (dub) from one tape deck onto another, you must indicate with this switch which deck is the source and which is recording. If you are recording from Tape 1 to Tape 2, press the Tape 1-2 button (indicator light is off). If you are recording from Tape 2 to Tape 1, press the Tape 2-1 button (indicator light turns on).

④ Monitor

This button selects the source signal or output of the tape decks for monitoring.

⑤ EQ Rec

Press the EQ Rec switch to use the graphic equalizer while recording any source onto tape (indicator light turns on).

⑥ Vol + / Vol - (Volume Up/Volume Down)

Press the Vol+ once to increase the volume one step, or hold the button in for a continuous increase. Press the Vol- button once to decrease the volume one step, or hold the button in for continuous decrease.

⑦ Sen + / Sen -

These two switches adjust the Spectrum Display Sensitivity to show the relative levels of the twelve frequency bands. As with the Volume + and Volume - switches, press either Display Sen + or Sen - switch once to increase or decrease the display one step, or hold in either switch to increase or decrease continuously. Adjust the display sensitivity so that low level signals will be displayed and high level signals do not peak out of range. These switches do not affect actual volume levels or equalization of the twelve frequency bands. They merely control the Spectrum Display Sensitivity.

⑧ Equalization Channel Selectors **BEEP**

EQ L/EQ R: Press these buttons to adjust the left or right channel frequency levels through the Equalization Level Controls.

EQ L-R: Press this button to adjust both left and right channels simultaneously. If you have set R and L channels at different equalizations because of your room's acoustics, then in this setting the two channels will retain their distinctions yet raise and lower at the same rate.

⑨ ME (Memory Entry) **BEEP**

This switch prepares the **EQ NINE** to store an Equalization Curve in its memory. After establishing the frequency setting you want with the Equalization Controls, press the ME switch. The indicator in the switch will flash, showing that the memory is ready to receive the curve. When you press one of the four Memory Preset Switches (M1-M4),

the curve is stored and the Memory light will stop flashing. If you want to cancel the command for the Memory to receive a curve, simply press the Memory button again. The light will stop flashing.

10 Memory Preset Switches M1, M2, M3, M4 BEEP

Each of these four switches has two functions: to store an Equalization Curve setting in the Memory and to recall that curve in the future.

To store: When you have established an Equalization Curve that you want to preserve, press ME and notice its flashing light. Then press the Preset switch you want to store the setting in (M1-M4), either filling an empty spot or overriding a previous setting. That setting will remain in the Memory until you override it. You may want to make a note of what setting you have put into each Memory bank (i.e.: M1 – CD, M2 – Tuner, M3 – Tape, and M4 – Turntable; or M1 – Rock, M2 – Jazz, M3 – Pop, and M4 – Classical).

To recall: Simply press a Memory Preset Switch (M1 – M4) to recall its setting from the Memory. You can change the setting at that moment without losing the memory by pressing any one or more of the twelve Equalization Level controls. This way you can alter the remembered setting and still return to it by pressing the Memory Preset Switch again. An indicator light signifies which Memory Preset Switch is activated.

Important: When a power line interruption occurs, the information stored in the memory will be erased. Therefore we suggest that you write down the settings you have stored for future reference.

11 Flat BEEP

Press this switch for a flat response, leveling all frequency adjustments to the "0" dB level (indicated by the green row of lights on the Display).

12 Mute BEEP

Press this switch to mute the sound without interrupting the source or changing the volume setting. Press again to restore the sound at precisely the same volume.

13 Pause BEEP

Press the Pause switch when the Display is working in the Spectrum mode, that is when the twelve light indicators are moving with the sound fluctuations. This switch has three functions:

- A. Press it once and the Spectrum Display will hold the highest level that has registered in the display and hold it for three seconds or until that level has been overtaken by a higher reading, which in turn will be held for three seconds or until overtaken. Essentially, this function holds the indicators at the

peaks so you can read several levels before the lights fall back down.

- B. When you press and hold the switch in, it will freeze the Spectrum Display, so you can study a specific moment of sound, such as a crescendo, the entrance of an unusual instrument, or a deep voice.
- C. Press the switch again to take out the feature described in step A.

14 Graph BEEP

This switch alternates the equalizer Display between the Graphic and Spectrum modes. The display will automatically return to the Spectrum mode in fifteen seconds, or you can manually return to the Spectrum mode by pressing the switch again.

15 Graphic/Spectrum Display

The function of the Display is controlled by the Graphic/Spectrum switch and the twelve Equalization Level switches just below the Display. This Display doubles as a Graphic/Spectrum Display. You can alternate between these two modes by using the Graph switch.

A. *As a Graphic Indicator:*

It shows the cut or boost of each individual frequency band; 25 Hz to 16 KHz. The light in each band changes its position, corresponding to a boost or cut, when you press the Equalization Level switch just below it. After 15 seconds, if no other buttons are pressed the display automatically goes back to Spectrum Display mode.

B. *As a Spectrum Indicator:*

It shows the fluctuating output signal in each of the twelve frequency bands as the sound passes through the equalizer. To make viewing easier, the indicator lights fall more slowly than they rise. When in the Spectrum mode, the Display will shift over to the Graph mode for about fifteen seconds and then back whenever you press any of the following switches: Equalization Level Up/Down switches, Memory Preset switches (M1- M4), ME Switch, Flat switch, EQ L, EQ R, or EQ L-R, switches. You can make the Display return to Spectrum immediately by pressing the Graph switch.

**16 Average Level Indicator:
L-Channel/R-Channel**

Located at the far right side of the Display, this indicator shows the relative input level for each channel.

17 Equalization Level Up/Down Controls BEEP

Each switch controls one frequency band between the range 25Hz to 16KHz, and cut or boost of each band can be varied a total of +/-12dB by pressing the top (up) or bottom (down) portion of each switch. When you press

one of the Equalization Level switches, the Display above immediately shifts into the Graphic mode and shows you the settings of all twelve bands. After about fifteen seconds, the Display shifts back into the Spectrum mode. Adjust the equalization level one band, one switch at a time. Press a switch once and the level changes one step. Hold the switch in and the level changes continuously.

EQUALIZING MUSIC

The fundamental range for most instruments falls between 63Hz and 4.5KHz, easily within the range of human hearing and your equalizer's control. Within this fundamental range instruments sound surprisingly similar, whereas the overtones or harmonics above the fundamental range give each instrument its timbre, its distinct character. Still, it is the mid-range controls that you will hear the greatest effect upon the sound coming through the equalizer and your speakers. Therefore, smaller changes in the mid range settings will produce more noticeable sound alteration while larger changes in the outer octaves of extreme high and low frequencies will produce less apparent effects.

Total power response, sound reflection included, is the most significant influence in our perception of tonal balance. Direct sounds that are not reflected off of walls, curtains, furniture, etc. determine our ability to locate instruments in the composite sound. The **EQ NINE** gives you the power to adjust each channel separately; we only recommend doing so if your speakers are arranged in an asymmetrical environment. In a symmetrical room and speaker arrangement you will probably want to use the

same equalization curve for both speakers to achieve the best stereo imaging. If your environment or speakers are different, you may want to equalize them separately.

When recordings are made, microphones are often placed so close to the instruments that they capture mostly direct sound, losing the roll-off produced by the reverberant sound. Therefore, the flat response of a hi-fi system will tend to reproduce higher frequencies more intensely than one would hear during a live performance. You may find in many instances that a slight diminishment or roll-off in the high frequencies will produce a more realistic and satisfying sound, particularly at the 16KHz level.

Caution: *Extreme boosts of lower bass or higher treble frequencies can overload the capacity of your amplifier or speakers, causing distortion in the amplifier or damage to your speakers. Therefore, exercise moderation in the highs and lows. Also, since the tone controls on your preamp or receiver and the Equalization Level controls on the equalizer both affect the tone frequency level, their effect is cumulative. We recommend leaving the tone controls and/or contour boost switch of your preamplifier or receiver in the flat position.*

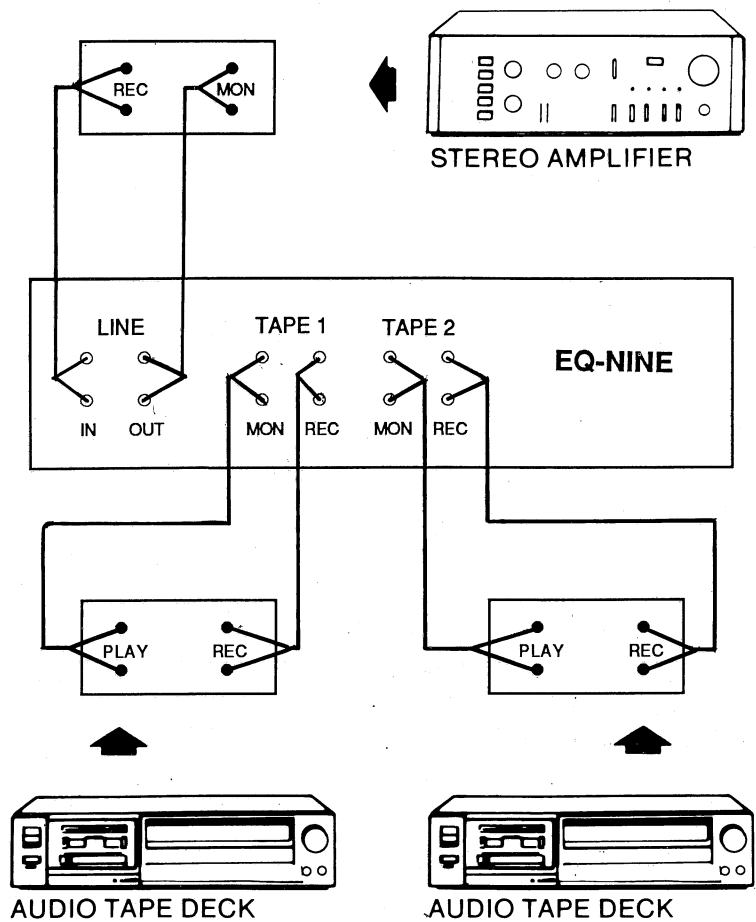

The chart below will help you identify which sliders on the GRAPHIC EQUALIZER Section (3) will most affect the sound and balance of particular instruments by illustrating where they lie in the overall sonic spectrum.

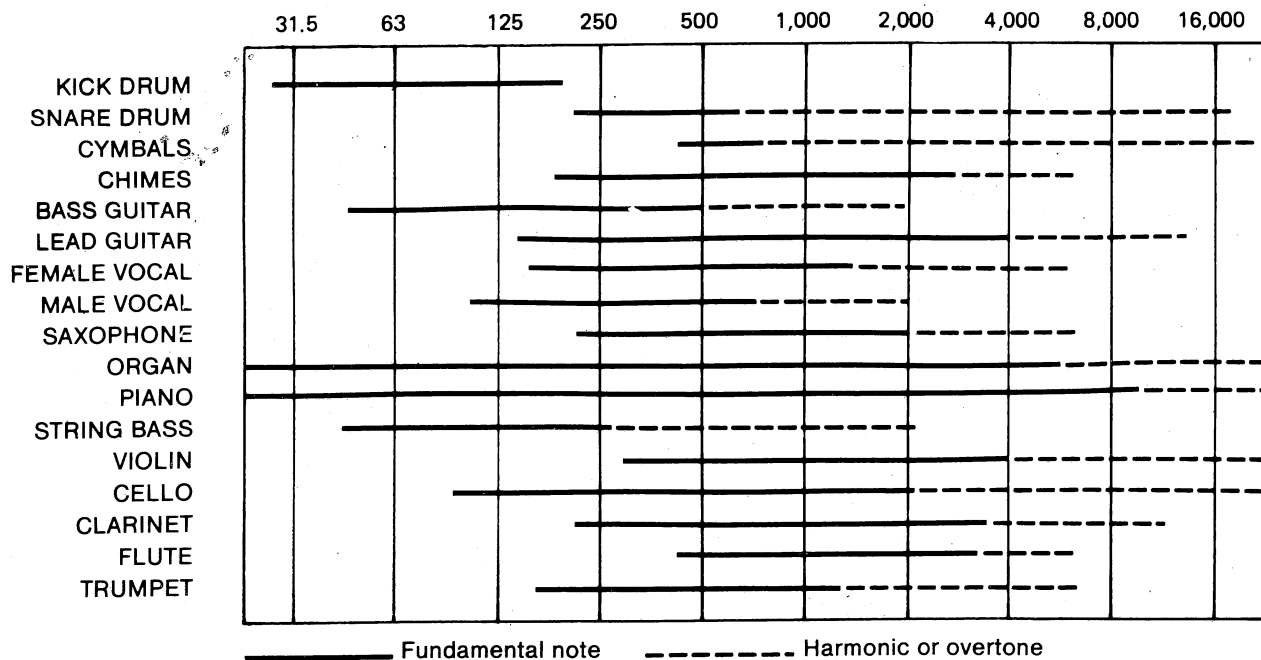

Specifications

EQUALIZER SECTION

| | |
|-----------------------|----------------------------------|
| Frequency Response | 5Hz - 120KHz ± 1 dB |
| Gain (Flat Position) | Unity Gain (± 1 db) |
| Distortion | 0.008% at 1V Output |
| Hum & Noise | -99.7dB re 1V |
| Maximum Input | 4.0V |
| Minimum Input | 4.0V |
| Input Impedance | 47K ohms |
| Output Impedance | 600 ohms |
| Control Center Points | 25, 40, 63, 100, 160, 250, 500Hz |
| | 1K, 2K, 4K, 8K, 16KHz |
| Control Range | ± 12 dB |

REAL TIME ANALYZER SECTION

| | |
|-----------------|--|
| LED Display | 154 (12 Green, 142 Red) |
| Input Impedance | 47K ohms |
| Display Range | ± 12 dB |
| Display Mode | Instantaneous Response, Momentary Peak Hold, Continuous Peak Hold |

| | |
|-------------|-------------------------|
| SIZE | 16.5"W x 3.5"H x 8.75"D |
|-------------|-------------------------|

| | |
|---------------|-------------|
| WEIGHT | 7 lbs. 8oz. |
|---------------|-------------|

Designs and specifications subject to change without notice.

Free Manuals Download Website

<http://myh66.com>

<http://usermanuals.us>

<http://www.somanuals.com>

<http://www.4manuals.cc>

<http://www.manual-lib.com>

<http://www.404manual.com>

<http://www.luxmanual.com>

<http://aubethermostatmanual.com>

Golf course search by state

<http://golfingnear.com>

Email search by domain

<http://emailbydomain.com>

Auto manuals search

<http://auto.somanuals.com>

TV manuals search

<http://tv.somanuals.com>