

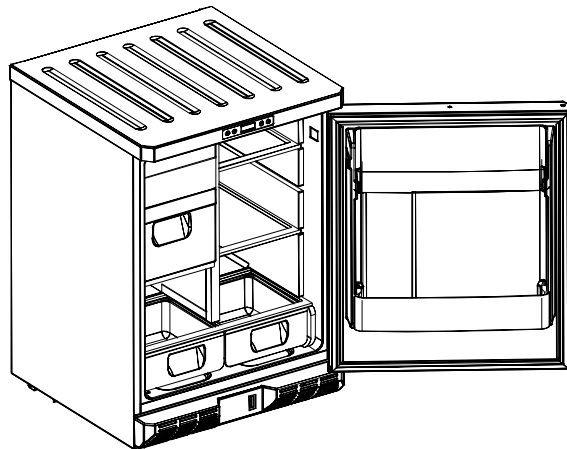

**ICE MAKER COMBO / REFRIGERADOR CON MAQUINA DE HACER HIELO  
INSTRUCTION MANUAL / MANUAL DE INSTRUCCIONES**

**MODEL NUMBER / NO. DE MODELO:           IMR28SS**



**BEFORE USE, PLEASE READ AND FOLLOW ALL SAFETY RULES AND OPERATING INSTRUCTIONS.**

LA SECCION EN ESPAÑOL EMPIEZA EN LA PAGINA 15.

AVANTI HAS A POLICY OF CONTINUOUS IMPROVEMENT ON ITS PRODUCTS AND RESERVES THE RIGHT TO CHANGE MATERIALS AND SPECIFICATIONS WITHOUT NOTICE.

---

**AVANTI PRODUCTS, A DIVISION OF THE MACKLE CO., INC.  
P.O. BOX 520604 - MIAMI, FLORIDA 33152  
WWW.AVANTIPRODUCTS.COM**

---

## ICE MAKER SAFETY

**Your safety and the safety of others are very important.**

We have provided many important safety messages in this manual for your appliance. Always read and obey all safety messages.



This is the Safety Alert Symbol. This symbol alerts you to potential hazards that can kill or injure you and others. All safety messages will follow the Safety Alert Symbol with either the words "DANGER", "WARNING" or "CAUTION".



Danger means that failure to heed this safety statement may result in severe personal injury or death.



Warning means that failure to heed this safety statement may result in extensive product damage, serious personal injury, or death.



Caution means that failure to heed this safety statement may result in minor or moderate personal injury, property or equipment damage.

All safety messages will alert you to what the potential hazard is, tell you how to reduce the chance of injury, and let you know what can happen if the instructions are not followed.

## IMPORTANT SAFEGUIDES



Before the appliance is used, it must be properly positioned and installed as described in this manual, so read the manual carefully. To reduce the risk of fire, electrical shock or injury when using the appliance, follow basic precautions, including the following:

### **DANGER**

- Plug into a grounded 3-prong outlet, do not remove grounding prong, do not use an adapter, and do not use an extension cord.
- Replace all panels before operating.
- It is recommended that a separate circuit, serving only your appliance be provided. Use receptacles that cannot be turned off by a switch or pull chain.
- Never clean appliance parts with flammable fluids. These fumes can create a fire hazard or explosion. And do not store or use gasoline or other flammable vapors and liquids in the vicinity of this or any other appliance. The fumes can create a fire hazard or explosion.
- Before proceeding with cleaning and maintenance operations, make sure the power line of the unit is disconnected.
- Do not connect or disconnect the electric plug when your hands are wet.
- Unplug the appliance or disconnect power before cleaning or servicing. Failure to do so can result in electrical shock or death.
- Do not attempt to repair or replace any part of your appliance unless it is specifically recommended in this manual. All other servicing should be referred to a qualified technician.

### **WARNING**

**FOLLOW WARNING CALL OUTS BELOW ONLY WHEN APPLICABLE TO YOUR MODEL**

- Use two or more people to move and install appliance. Failure to do so can result in back or other injury.
- To ensure proper ventilation for your appliance, the front of the unit must be completely unobstructed. Choose a well-ventilated area with temperatures above 60°F (16°C) and below 90°F (32°C). This unit must be installed in an area protected from the elements, such as wind, rain, water spray or drips.
- The appliance should not be located next to ovens, grills or other sources of high heat.
- The appliance must be installed with all electrical, water and drain connections in accordance with state and local codes. A standard electrical supply (115 V AC only, 60 Hz), properly grounded in accordance with the National Electrical Code and local codes and ordinances is required.
- Do not kink or pinch the power supply cord of appliance.
- The fuse (or circuit breaker) size should be 15 amperes.
- It is important for the appliance to be leveled in order to work properly. You may need to make several adjustments to level it.
- All installation must be in accordance with local plumbing code requirements.
- Make certain that the pipes are not pinched or kinked or damaged during installation.
- Check for leaks after connection.
- Never allow children to operate, play with or crawl inside the ICE MAKER.
- If you use the drainage container, you MUST set the Drain Select switch to OFF or the water can overflow from the drainage container
- Although the unit has been tested at the factory, due to long-term transit and storage, the first batch of ice cubes must be discarded.
- Do not use solvent-based cleaning agents or abrasives on the interior. These cleaners may damage or discolor the interior.
- Do not use this apparatus for other than its intended purpose.

---

## HELP US HELP YOU ...

### READ THIS GUIDE CAREFULLY.

IT IS INTENDED TO HELP YOU OPERATE AND MAINTAIN YOUR NEW APPLIANCE PROPERLY.

KEEP IT HANDY TO ANSWER YOUR QUESTIONS.  
IF YOU DON'T UNDERSTAND SOMETHING OR YOU NEED FURTHER assistance, PLEASE CALL:

**AVANTI CUSTOMER SERVICE**  
**800-220-5570**

KEEP PROOF OF ORIGINAL PURCHASE DATE (SUCH AS YOUR SALES SLIP) WITH THIS GUIDE TO ESTABLISH THE WARRANTY PERIOD.

### **CAUTION:**

THIS APPLIANCE IS NOT DESIGNED FOR THE STORAGE OF MEDICINE OR OTHER MEDICAL PRODUCTS.

### WRITE DOWN THE MODEL AND SERIAL NUMBERS.

YOU'LL FIND THEM ON A PLATE LOCATED ON THE REAR WALL OF THE APPLIANCE.

PLEASE WRITE THESE NUMBERS HERE:

\_\_\_\_\_  
DATE OF PURCHASE

\_\_\_\_\_  
MODEL NUMBER

\_\_\_\_\_  
SERIAL NUMBER

USE THESE NUMBERS IN ANY CORRESPONDENCE OR SERVICE CALLS CONCERNING YOUR APPLIANCE.

IF YOU RECEIVED A DAMAGED APPLIANCE, IMMEDIATELY CONTACT THE DEALER (OR BUILDER) THAT SOLD YOU THE APPLIANCE.

SAVE TIME AND MONEY. BEFORE YOU CALL FOR SERVICE, CHECK THE TROUBLESHOOTING GUIDE. IT LISTS CAUSES OF MINOR OPERATING PROBLEMS THAT YOU CAN CORRECT YOURSELF.

---

## IF YOU NEED SERVICE

WE'RE PROUD OF OUR SERVICE AND WANT YOU TO BE PLEASED. IF FOR SOME REASON YOU ARE NOT HAPPY WITH THE SERVICE YOU RECEIVE, HERE ARE SOME STEPS TO FOLLOW FOR FURTHER ASSISTANCE.

FIRST, CONTACT THE PEOPLE WHO SERVICED YOUR APPLIANCE. EXPLAIN WHY YOU ARE NOT PLEASED. IN MOST CASES, THIS WILL SOLVE THE PROBLEM.

NEXT, IF YOU ARE STILL NOT PLEASED, WRITE ALL THE DETAILS, INCLUDING YOUR TELEPHONE NUMBER, AND SEND IT TO:

**CUSTOMER SERVICE**  
**AVANTI PRODUCTS**  
**10880 NW 30<sup>th</sup> STREET**  
**MIAMI, FL 33172 USA**

## PARTS AND FEATURES

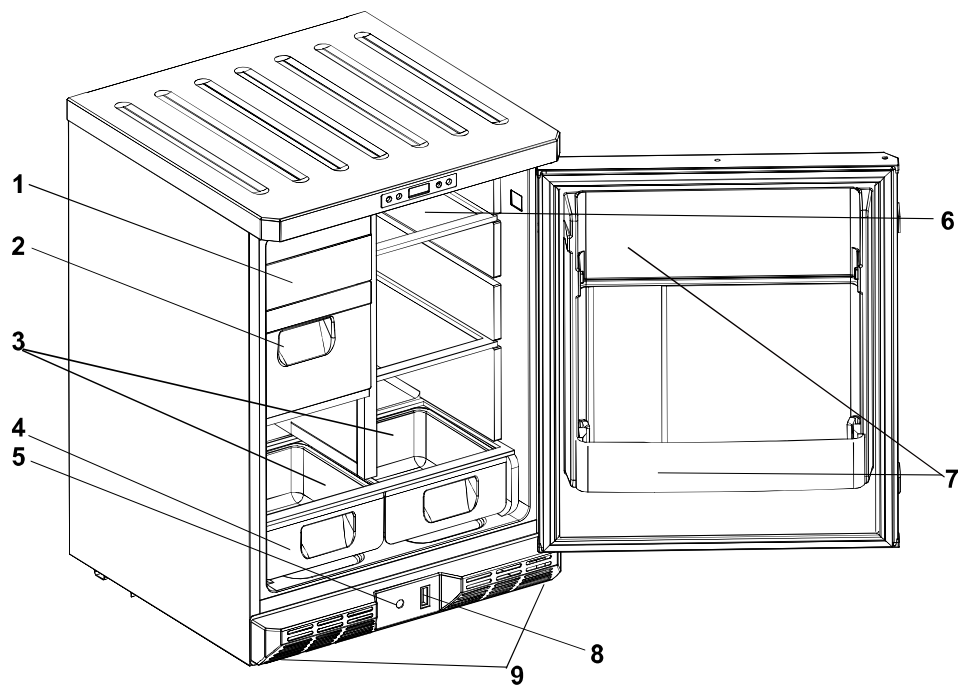

1. FREEZER DOOR
2. ICE BOX
3. GLASS CRISPER LID
4. CRISPER DRAWERS
5. ON / OFF CONTROL SWITCH
6. TEMPERATURE CONTROL
7. DOOR BINS
8. BOTTOM GRILLE
9. ADJUSTABLE LEG

## TABLE OF CONTENTS

ICE MAKER SAFETY _____	2
IMPORTANT SAFEGUIDES _____	3
HELP US AND HELP YOU ... _____	4
PARTS AND FEATURES _____	5
IMPORTANT SAFETY INSTRUCTIONS _____	7
INSTALLATION INSTRUCTIONS _____	7
BEFORE USING YOUR APPLIANCE _____	7
INSTALLATION OF YOUR APPLIANCE _____	7
ELECTRICAL CONNECTION _____	8
EXTENSION CORD _____	8
CONNECTING THE WATER SUPPLY _____	8
REVERSING THE DOOR SWING OF YOUR APPLIANCE _____	9
OPERATING YOUR ICE MAKER _____	9
INITIAL START-UP ICE MAKING OPERATION _____	9
CARE AND MAINTENANCE _____	11
CLEANING YOUR APPLIANCE _____	11
POWER FAILURE _____	11
VACATION TIME/STORAGE _____	11
MOVING YOUR APPLIANCE _____	11
ENERGY SAVING TIP _____	11
TROUBLESHOOTING GUIDE _____	12
SERVICE FOR YOUR APPLIANCE _____	13
WIRING DIAGRAM _____	13
YOUR AVANTI PRODUCTS WARRANTY _____	14
INSTRUCCIONES EN ESPAÑOL _____	15-18
REGISTRATION INFORMATION _____	19

## IMPORTANT SAFETY INSTRUCTIONS

<b>⚡WARNING⚡</b>	TO REDUCE THE RISK OF FIRE, ELECTRICAL SHOCK, OR INJURY WHEN USING YOUR APPLIANCE, FOLLOW THESE BASIC PRECAUTIONS:
<ul style="list-style-type: none"><li>• READ ALL INSTRUCTIONS BEFORE USING THE APPLIANCE.</li><li>• <b>DANGER OR WARNING:</b> RISK OF CHILD ENTRAPMENT. CHILD ENTRAPMENT AND SUFFOCATION ARE NOT PROBLEMS OF THE PAST. JUNKED OR ABANDONED APPLIANCES ARE STILL DANGEROUS. . . EVEN IF THEY WILL "JUST SIT IN THE GARAGE A FEW DAYS."</li><li>• <b>BEFORE YOU THROW AWAY YOUR APPLIANCE:</b> REMOVE THE DOORS. LEAVE THE SHELVES IN PLACE SO THAT CHILDREN MAY NOT EASILY CLIMB INSIDE.</li><li>• NEVER ALLOW CHILDREN TO OPERATE, PLAY WITH, OR CRAWL INSIDE THE APPLIANCE.</li><li>• NEVER CLEAN APPLIANCE PARTS WITH FLAMMABLE FLUIDS. THE FUMES CAN CREATE A FIRE HAZARD OR EXPLOSION.</li><li>• DO NOT STORE OR USE GASOLINE OR ANY OTHER FLAMMABLE VAPORS AND LIQUIDS IN THE VICINITY OF THIS OR ANY OTHER APPLIANCE. THE FUMES CAN CREATE A FIRE HAZARD OR EXPLOSION.</li></ul> <p style="text-align: center;">-SAVE THESE INSTRUCTIONS-</p>	

## INSTALLATION INSTRUCTIONS

### BEFORE USING YOUR APPLIANCE

- Remove the exterior and interior packing.
- Check to be sure you have all of the following parts:
  - 1 ice box
  - 2 door bins
  - 2 crisper drawers
  - 2 glass shelves
  - 1 plastic scoop
  - 25 feet hose
  - 1 glass crisper lid
  - 1 instruction manual
  - 1 door handle assembly
- Before connecting the appliance to the power source, let it stand upright for approximately 2 hours. This will reduce the possibility of a malfunction in the cooling system from handling during transportation.
- Clean the interior surface with lukewarm water using a soft cloth.

### INSTALLATION OF YOUR APPLIANCE

- This appliance is designed to be recessed or built-in (fully recessed).
- Place your appliance on a floor that is strong enough to support the appliance when it is fully loaded. Remember that the unit will be significantly heavier once it is fully loaded. To level your appliance, adjust the legs at the front of the appliance.
- Locate the appliance away from direct sunlight and sources of heat (stove, heater, radiator, etc.). Direct sunlight may affect the acrylic coating and heat sources may increase electrical consumption. Extreme cold ambient temperatures may also cause the appliance not to perform properly.
- Avoid locating the appliance in moist areas. Too much moisture in the air will cause frost to form quickly on the evaporator requiring more frequent defrosting of the appliance.
- Plug the appliance into an exclusive properly-installed and grounded wall outlet. Do not under any

circumstances cut or remove the third (ground) prong from the power cord. Any questions concerning power and/or grounding should be directed toward a certified electrician or an authorized Avanti Products service center.

## ELECTRICAL CONNECTION

### **⚡ WARNING ⚡**

IMPROPER USE OF THE GROUNDED PLUG CAN RESULT IN THE RISK OF ELECTRICAL SHOCK. IF THE POWER CORD IS DAMAGED, HAVE IT REPLACED BY AN AUTHORIZED AVANTI PRODUCTS SERVICE CENTER.

- This appliance should be properly grounded for your safety. The power cord of this appliance is equipped with a three-prong plug which mates with standard three prong wall outlets to minimize the possibility of electrical shock.
- Do not under any circumstances cut or remove the third ground prong from the power cord supplied.
- Never use an extension cord to connect power to the unit.
- Never use a two-prong grounding adapter.
- Where a two-prong wall receptacle is encountered, contact a qualified electrician to have it replaced with a 3-prong receptacle in accordance with applicable electrical codes.
- This appliance requires a standard 115/120 volts a.c./60hz electrical ground outlet with three-prong receptacle.
- The cord should be secured behind the appliance and not left exposed or dangling, in order to prevent accidental injury.
- The appliance should always be plugged into its own individual electrical outlet which has a voltage rating that matches the rating label on the appliance. This provides the best performance and also prevents overloading of house wiring circuits, which could result in a fire hazard. Never unplug the appliance by pulling the power cord. Always grip the plug firmly and pull straight out from the receptacle. Repair or replace immediately all power cords that have become frayed or otherwise damaged. Do not use a cord that shows cracks or abrasion damage along its length or at either end. When moving the appliance, be careful not to damage the power cord.

## EXTENSION CORD

Because of potential safety hazards under certain conditions, it is strongly recommended that you do not use an extension cord with this appliance. However, if you must use an extension cord it is absolutely necessary that it be a UL/CUL-Listed, 3-wire grounding type appliance extension cord having a grounding type plug and outlet, and that the electrical rating of the cord be 115 volts and at least 10 amperes.

### ➤ CONNECTING THE WATER SUPPLY

- Review the state and local plumbing codes before you install the unit. All the necessary hardware is not provided for installation so you must hire a professional licensed plumber to complete the installation.
- Connect tubing (supplied with unit) to the nearest cold water source. Connect sufficient tubing to the unit to allow the appliance to be moved freely for cleaning and service. Also make sure that the tubing is not pinched or damaged during transportation.
- Position unit to allow free airflow through the front grille (see sketch 1). Wipe off inside of unit and ice bucket with a damp cloth.



SKETCH 1



## REVERSING THE DOOR SWING OF YOUR APPLIANCE

This appliance has the capability of the door opening from either the left or right side. The unit is delivered to you with the door opening from the left side. Should you desire to reverse the opening direction, please call customer service for reversal instructions.

## OPERATING YOUR ICE MAKER

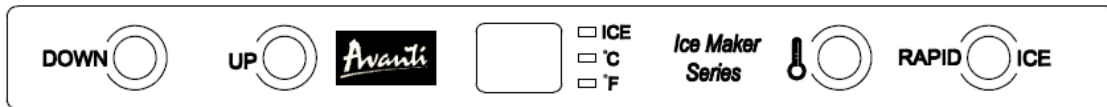

### ★ INITIAL START-UP ICE MAKING OPERATION

1. Plug the appliance into a 115/120v polarized and grounded wall electrical outlet.
2. To run the refrigerator, place the on-off switch, located on the front grille, in the "on" position

### ★ RAPID ICE MAKING

1. When the rapid ice button is pushed, the system will begin to make ice. The rapid ice indicator will appear on display, and "00" will be displayed on temperature window.
2. During rapid ice making cycle, other buttons are disabled.
3. Push the rapid ice button again and the system will be switched to refrigerator mode. You can set temperature as you desire.

### SETTING THE TEMPERATURE

1. The temperature range is between 37 to 50°F (3-10°C). You can set the temperature as you desire by pushing the **UP** or **DOWN** button. When you push the two buttons for the first time, the LED readout will show the original temperature set previously (the default temperature preset is 46°F)
2. The temperature setting will increase 1°F or 1°C each time the **UP** button is pressed, and will decrease 1°F or 1°C each time the **DOWN** button is pressed

### ★ SETTING DEFROST

1. System will defrost automatically every 6 hours.
2. If you wish to defrost the unit manually, push all the 4 buttons simultaneous for 2 seconds, the system will defrost.

### FAHRENHEIT / CELSIUS SWITCH

You can switch the temperature display setting from Fahrenheit to Celsius by pushing the "Thermometer" button. An indicator will appear on the display accordingly.

### INTERIOR LIGHT

When the door is opened or closed, the interior LED light will turn on or off automatically.

Note:

1. When there is system malfunction, "ex" will be displayed on the digital LED display.
2. If the unit is unplugged, has lost power, or is turned off, you must wait 2 minutes before restarting the unit. If you attempt to restart before this time delay, the appliance will not start.

### **IMPORTANT: Throw away all ice cubes made during the first 3 hours of operation.**

- Make sure the water supply is on. As soon as the inner mechanism reaches the proper temperature, the icemaker mechanism will fill the mold with water.
- The first cubes may be small because of air in the water line. Later cubes will be of standard

- crescent moon type size and shape.
- Approximate time for the first cycle is between 30-40 minutes.
- Each cycle will use approximately 140 ml of water, so you should have a full tray after 11 hours.

- When the ice bucket is full, the ice making mechanism will automatically shut off. However the refrigeration system will continue to cool and maintain the cube supply.
- Ice delivery may be interrupted by raising the metal arm into an upright position (see sketch 2)
- If the icemaker is not used regularly, it is recommended that the ice bucket be emptied periodically to ensure fresh ice.
- Sometimes the cubes may appear cloudy. This no cause for concern and has nothing to do with the taste or chemical make-up of the water.
- The front bottom grille should be kept free of dust and lint to permit free airflow.

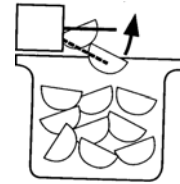

SKETCH 2

## CARE AND MAINTENANCE

### Cleaning your appliance

- Turn the unit off, unplug the appliance and remove all buckets, drawers, crispers and shelves.
- Wash the inside with a warm water and baking soda solution. The solution should be about 2 tablespoons of baking soda to a quart of water.
- Wash the bucket, drawers and crispers with a mild detergent solution.
- The outside of the appliance should be cleaned with mild detergent and warm water.
- The condenser should be vacuumed when it becomes dusty or dirty.

### **CAUTION:**

**Failure to unplug the appliance could result in electrical shock or personal injury.**

### Power failure

Most power failures are corrected within a few hours and should not affect the temperature of your appliance if you minimize the number of times the door is opened. If the power is going to be off for a longer period of time, you need to take the proper steps to protect your food.

### Vacation time/storage

1. Shut off water supply at the main water valve.
2. Disconnect the water supply line from the valve.
3. Allow unit to run for an hour or two until all remaining ice cubes have been ejected.
4. Disconnect unit from main power source.
5. Dry out excess water from ice making mechanism.
6. Leave the door open at least two inches.

### Moving your appliance

- Securely tape down all loose items inside your appliance.
- Turn the leveling screw up to the base to avoid damage.
- Tape the door shut.
- Be sure the appliance stays in the upright position during transportation.

### Energy saving tip

- The appliance should be located in the coolest area of the room, away from heat producing appliances or heating ducts, and out of the direct sunlight.

## PROBLEMS WITH YOUR APPLIANCE?

You can solve many common appliance problems easily, saving you the cost of a possible service call. Try the suggestions below to see if you can solve the problem before calling a servicer.

### TROUBLESHOOTING GUIDE

PROBLEM	POSSIBLE CAUSE
Appliance does not operate	Not plugged in. The circuit breaker tripped or there is a blown fuse. The appliance has not been turned on.
Not producing ice, unit not cold enough	Airflow to front grille blocked. The appliance arm is set to the off position. Water supply is turned off. Water line is crimped.
Compressor turns on and off frequently	The room temperature is hotter than normal. The door is opened too often. The door is not closed completely. The door gasket does not seal properly. The appliance does not have the correct clearances.
Vibrations	Check to assure that the appliance is level.
The appliance seems to make too much noise.	The rattling noise may come from the flow of the refrigerant, which is normal. As each cycle ends, you may hear gurgling sounds caused by the flow of refrigerant in your appliance. Contraction and expansion of the inside walls may cause popping and crackling noises. The appliance is not level.
The door will not close properly	The appliance is not level. The door is reversed and not properly installed. The gasket is dirty. The bucket is out of position.
Ice cubes are melted together	Appliance door is opened too often.

## SERVICE FOR YOUR APPLIANCE

We are proud of our customer service organization and the network of professional service technicians that provide service on your Avanti appliance. With the purchase of your Avanti appliance, you can be confident that if you ever need additional information or assistance, the Avanti Products customer service team will be here for you. Just call us toll-free.

### AVANTI PRODUCTS CUSTOMER SERVICE

<b>PRODUCT INFORMATION</b> 800-323-5029	Whatever your questions are about our products, help is available.
<b>PART ORDERS</b> 800-220-5570	You may order parts and accessories that will be delivered directly to your home, by personal check, money order, MasterCard, or Visa.
<b>IN-HOME REPAIR SERVICE</b> 800-220-5570	An Avanti Products authorized service center will provide expert repair service, scheduled at a time that is convenient for you. Our trained servicers know your appliance inside and out.

### WIRING DIAGRAM

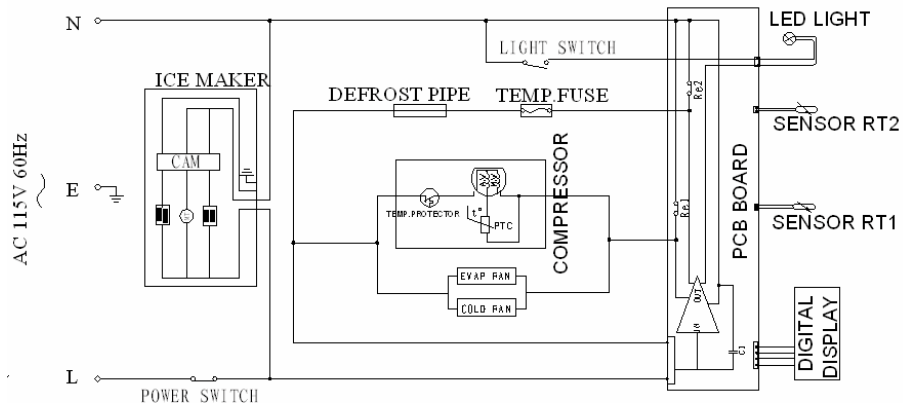

**YOUR AVANTI PRODUCTS  
WARRANTY**

**STAPLE YOUR SALES RECEIPT HERE.  
PROOF OF ORIGINAL PURCHASE DATE IS  
NEEDED TO OBTAIN SERVICE UNDER  
WARRANTY.**

**WHAT IS COVERED**

**LIMITED ONE-YEAR  
WARRANTY**

FOR ONE YEAR FROM THE DATE OF PURCHASE BY THE ORIGINAL OWNER, AVANTI PRODUCTS WILL, AT ITS OPTION, REPAIR OR REPLACE ANY PART OF THE APPLIANCE WHICH PROVES TO BE DEFECTIVE IN MATERIAL OR WORKMANSHIP UNDER NORMAL USE. DURING THIS PERIOD AVANTI PRODUCTS WILL PROVIDE ALL PARTS AND LABOR NECESSARY TO CORRECT SUCH DEFECTS FREE OF CHARGE, SO LONG AS THE APPLIANCE HAS BEEN INSTALLED AND OPERATED IN ACCORDANCE WITH THE WRITTEN INSTRUCTIONS IN THIS MANUAL. IN RENTAL OR COMMERCIAL USE, THE WARRANTY PERIOD IS 90 DAYS. ALL AVANTI APPLIANCES OF 3.5 CUBIC FEET CAPACITY OR LESS MUST BE BROUGHT/SENT TO THE APPLIANCE SERVICE SHOP FOR REPAIR.

**LIMITED SECOND THROUGH  
FIFTH YEAR WARRANTY**

FOR THE SECOND THROUGH THE FIFTH YEAR FROM DATE OF ORIGINAL PURCHASE, AVANTI PRODUCTS WILL PROVIDE A REPLACEMENT COMPRESSOR FREE OF CHARGE DUE TO A FAILURE. YOU ARE RESPONSIBLE FOR THE SERVICE LABOR AND FREIGHT CHARGES. IN RENTAL OR COMMERCIAL USE, THE LIMITED COMPRESSOR WARRANTY IS ONE YEAR AND NINE MONTHS. COST TO MOVE THE APPLIANCE TO THE SERVICERS' SHOP AND BACK TO THE USER'S HOME, AS MAY BE REQUIRED, ARE THE USER'S RESPONSIBILITY.

---

**WHAT IS NOT COVERED**

- INCIDENTAL OR CONSEQUENTIAL DAMAGES.
- PARTS AND LABOR COSTS FOR THE FOLLOWING WILL NOT BE CONSIDERED AS WARRANTY:
  - DOOR SPRINGS AND/OR FRAMES.
  - INNER DOOR PANELS AND/OR DOOR SUPPORTS.
  - CHEST APPLIANCE LID LINERS.
  - PLASTIC CABINET LINERS.
  - THE REMOVAL AND REINSTALLATION OF YOUR APPLIANCE IF IT IS INSTALLED IN AN INACCESSIBLE LOCATION OR IS NOT INSTALLED IN ACCORDANCE WITH PUBLISHED INSTALLATION INSTRUCTIONS.
  - SHIPPING AND HANDLING COSTS ASSOCIATED WITH THE REPLACEMENT OF THE UNIT.
- REPAIRS PERFORMED BY UNAUTHORIZED SERVICERS.
- SERVICE CALLS THAT DO NOT INVOLVE DEFECTS IN MATERIAL OR WORKMANSHIP SUCH AS CUSTOMER EDUCATION, DOOR REVERSAL, OR PROPER INSTALLATION.
- SERVICE CALLS THAT ARE RELATED TO EXTERNAL PROBLEMS, SUCH AS ABUSE, MISUSE, INADEQUATE ELECTRICAL POWER, ACCIDENTS, FIRE, FLOODS, OR ACTS OF GOD.
- SURCHARGES INCLUDING, BUT NOT LIMITED TO, ANY AFTER HOUR, WEEKEND, OR HOLIDAY SERVICE CALLS, TOLLS, FERRY TRIP CHARGES, OR MILEAGE EXPENSES FOR SERVICE CALLS TO REMOTE AREAS, INCLUDING THE STATE OF ALASKA
- REPLACEMENT OF HOUSE FUSES OR RESETTING CIRCUIT BREAKERS.
- FAILURE OF THE PRODUCT IF IT IS USED FOR OTHER THAN ITS INTENDED PURPOSE.
- THIS WARRANTY DOES NOT APPLY OUTSIDE THE CONTINENTAL U.S.A.

## INSTRUCCIONES EN ESPAÑOL

<b>PRECAUCION</b>	PARA REDUCIR EL RIESGO DE INCENDIO, DESCARGA ELECTRICA, O DAÑO CUANDO USE SU ELECTRODOMESTICO, SIGA LAS SIGUIENTES PRECAUCIONES.
<ul style="list-style-type: none"><li>• LEA TODAS LAS INSTRUCCIONES ANTES DE USAR SU ELECTRODOMESTICO.</li><li>• PELIGRO O PRECAUCION: EXISTE EL RIESGO QUE LOS NIÑOS QUEDEN ATRAPADOS.</li><li>• NIÑOS ATRAPADOS O SOFOCAMIENTO NO SON UN PROBLEMA DEL PASADO. LOS ELECTRODOMESTICOS SON PELIGROSOS AUN SI SOLO LOS DEJA EN EL GARAJE POR UN PAR DE DIAS.</li><li>• ANTES DE DESECHAR SU MAQUINA DE HACER HIELO O REFRIGERADOR USADO: QUITELE LAS PUERTAS. DEJE LAS REPISAS EN SU LUGAR PARA EVITAR QUE LOS NIÑOS SE QUEDEN ATRAPADOS.</li><li>• NO PERMITA QUE LOS NIÑOS MANEJEN, JUEGUEN O ENTREN DENTRO DEL ELECTRODOMESTICO.</li><li>• NO LIMPIE SU ELECTRODOMESTICO CON LIQUIDOS INFLAMABLES. LOS GASES PUEDEN OCASIONAR FUEGO O UNA EXPLOSION.</li><li>• NO GUARDE NI USE GASOLINA U OTROS LIQUIDOS INFLAMABLES CERCA DE ESTE O DE CUALQUIER OTRO ELECTRODOMESTICO. LOS VAPORES PUEDEN OCASIONAR FUEGO O EXPLOSION.</li></ul> <p style="text-align: center;">- <u>GUARDE ESTAS INSTRUCCIONES.</u> -</p>	

### INSTRUCCIONES PARA LA INSTALACION

#### ➤ **ANTES DE USAR SU EQUIPO**

- RETIRE LA ENVOLTURA INTERNA Y EXTERNA.
- VERIFIQUE QUE TENGA LAS SIGUIENTES PARTES:
  - UNA GAVETA PARA HIELO
  - DOS GAVETAS CON FRENTE TRANSPARENTE, CON CRISTAL EN LA PARTE SUPERIOR
  - 2 COMPARTIMENTOS EN LA PUERTA
  - UN MANUAL DE INSTRUCCIONES
  - UN RECOJEDOR PLASTICO PARA DE HIELO
  - 8 METROS DE LINEA DE AGUA
  - UNA MANIJA
- ANTES DE CONECTAR SU ELECTRODOMESTICO A LA CORRIENTE ELECTRICA, UBIQUELO EN UNA SUPERFICIE PLANA POR LO MENOS POR 2 HORAS. ESTO REDUCIRA LA POSIBILIDAD DE MALFUNCIONAMIENTO EN EL SISTEMA DE ENFRIAMIENTO POR LA MANIPULACION DURANTE EL TRANSPORTE.
- LIMPIE LA SUPERFICIE INTERIOR CON AGUA TIBIA USANDO UN PAÑO SUAVE.
- COLOQUE LA UNIDAD DE MANERA QUE PERMITA LA CIRCULACION DEL AIRE A TRAVES DE LA REJILLA DELANTERA (DIBUJO 1). CON UN TRAPO LIMPIO Y HUMEDO LIMPIE LA UNIDAD POR DENTRO Y EL DEPOSITO DE HIELO.



DIBUJO 1

➤ **INSTALACION DE SU MAQUINA DE HACER HIELO**

- UBIQUE SU MAQUINA DE HACER HIELO EN UN PISO QUE SEA LO SUFICIENTEMENTE FUERTE, PARA SOPORTAR SU PESO CUANDO ESTE TOTALMENTE LLENO O CARGADO. PARA NIVELAR LA MAQUINA DE HACER HIELO, AJUSTE LAS PATAS DELANTERAS.
- NO ES NECESARIO DEJAR ESPACIO ENTRE LA PARTE TRASERA Y LOS COSTADOS DE SU ELECTRODOMESTICO SI LO QUIERE EMPOTRAR EN UN GABINETE.
- MANTENGA SU MAQUINA DE HACER HIELO ALEJADA DEL AIRE CALIENTE, VAPOR O LIQUIDOS QUE PUEDAN SALPICARLA, YA QUE LA UNIDAD PODRIA AVERIARSE.
- LOS RAYOS SOLARES DIRECTOS PUEDEN DAÑAR LA CAPA ACRILICA, Y LAS FUENTES DE CALOR PUEDEN OCASIONAR UN AUMENTO EN EL CONSUMO ELECTRICO. MANTENGALO LO MAS ALEJADO POSIBLE DEL AGUA PARA PREVENIR ALGUN CHOQUE ELECTRICO. EVITE LOS SITIOS HUMEDOS Y LOS AMBIENTES EXTREMADAMENTE FRIOS YA QUE ESTO PUEDE AFECTAR LA EFICIENCIA DEL ENFRIAMIENTO DE SU MAQUINA DE HACER HIELO.
- EVITE UBICAR SU MAQUINA DE HACER HIELO EN AREAS MOJADAS O MUY HUMEDAS. MUCHA HUMEDAD EN EL AIRE PUEDE CAUSAR LA FORMACION DE ESCARCHA RAPIDAMENTE Y NECESITARA DESCONGELAR SU MAQUINA DE HACER HIELO MAS FRECUENTEMENTE.
- CONECTE LA MAQUINA DE HACER HIELO A UN ENCHUFE DE PARED EXCLUSIVO E INSTALE EL CABLE DE TIERRA. BAJO NINGUNA RAZON SE DEBE RETIRAR LA TERCERA PUNTA DEL ENCHUFE. CUALQUIER CONSULTA CON RESPECTO A LA ENERGIA Y/O CABLE DE TIERRA DEBE SER DIRIGIDA A UN ELECTRICISTA CERTIFICADO O AUTORIZADO POR EL SERVICIO TECNICO DE AVANTI PRODUCTS.

➤ **CONEXION ELECTRICA-**

**ESTE ELECTRODOMESTICO DEBE SER CONECTADO A TIERRA. EN EL CASO QUE OCURRA UN CORTO CIRCUITO, LA CONEXION A TIERRA REDUCE EL RIESGO DE RECIBIR UN CHOQUE ELECTRICO YA QUE CUENTA CON UN ALAMBRE PARA EL ESCAPE DE LA CORRIENTE ELECTRICA. ESTE ELECTRODOMESTICO ESTA EQUIPADO CON UN ENCHUFE QUE CONSTA DE TRES PUNTAS, LA TERCERA PUNTA ES LA CONEXION A TIERRA. ESTE ENCHUFE DEBE SER INSERTADO A UN ENCHUFE DE PARED QUE ESTE CORRECTAMENTE INSTALADO CON LA CONEXION A TIERRA.**

**ADVERTENCIA**

- EL USO INAPROPIADO DEL ENCHUFE A TIERRA PUEDE DESENCADENAR UN CHOQUE ELECTRICO. CONSULTE EL PERSONAL AUTORIZADO DE AVANTI PRODUCTS SI TIENE ALGUNA DUDA SOBRE LAS INSTRUCCIONES O SI TIENE ALGUNA CONSULTA SI EL ELECTRODOMESTICO ESTA CORRECTAMENTE INSTALADO A LA CORRIENTE ELECTRICA Y A TIERRA. SI EL CORDON DEL ENCHUFE DEL ELECTRODOMESTICO SE ENCUENTRA DAÑADO, DEBE SER REEMPLAZADO POR EL SERVICIO TECNICO DE AVANTI PRODUCTS.

- EL CORDON DEL ENCHUFE ESTA EQUIPADO CON TRES PUNTAS QUE ENCAJAN PERFECTAMENTE EN UN ENCHUFE DE PARED STANDARD PARA REDUCIR EL RIESGO DE UN CHOQUE ELECTRICO.
- BAJO NINGUNA CIRCUNSTANCIA CORTE O SAQUE LA TERCERA PUNTA DEL ENCHUFE, YA QUE ESTE ES PARA QUE VAYA CONECTADO A TIERRA.
- NO USE UNA EXTENSION.
- EL VOLTATE DE ESTE ELECTRODOMESTICO ES DE 120 VOLTIOS AC, TIENE UNA SALIDA ELECTRICA DE 60 HZ. Y CONSTA DE UN ENCHUFE DE TRES PUNTAS QUE VA CONECTADO AL ENCHUFE DE PARED.
- EL CORDON DEL ENCHUFE DEBE SER ASEGURADO ATRAS DEL ELECTRODOMESTICO Y NO DEJARLO EXPUESTO PARA EVITAR ACCIDENTES.



## CONEXION A FUENTE DE AGUA

- ANTES DE INSTALAR LA UNIDAD VERIFIQUE LOS CODIGOS DE PLOMERIA EN SU ESTADO. RECOMENDAMOS QUE PARA LA INSTALACION USE UN PLOMERO PROFESIONAL Y CON LICENCIA.
- CONECTE EL TUBO (INCLUIDO) A LA FUENTE DE AGUA FRIA MAS CERCANA . INSTALE SUFICIENTE TUBERIA A LA UNIDAD PARA PERMITIRLE MOVIMIENTO LIBRE DURANTE LA LIMPIEZA Y EL SERVICIO. ASEGURESE QUE LA TUBERIA NO SEA APLASTADA O DAÑADA DURANTE EL TRANSPORTE.

## OPERACION INICIAL

1. CONECTE EL APARATO A UN ENCHUFE DE PARED DE 120V AC, POLARIZADO Y CON SALIDA A TIERRA.
2. PARA PRODUCIR HIELO, ENCIENDA LA UNIDAD COLOCANDO EL INTERRUPTOR EN LA POSICION "ON".
3. EMPUJE EL BOTON MARCADO "RAPID ICE" (HIELO RAPIDO) Y LA MAQUINA EMPEZARA A HACER HIELO. EL INDICADOR LLAMADO "RAPID ICE" APARECERA ILUMINADO EN LA PANTALLA. DURANTE ESTE PROCESO TODAS LAS OTRAS OPERACIONES SON INVALIDAS
4. EL RANGO DE TEMPERATURA ES DE 3 – 10°C (37 – 50°F). UD. PUEDES SELECCIONAR LA TEMPERATURA APRETANDO EL BOTON MARCADO "UP" (ARRIBA) O "DOWN" (ABAJO). LA TEMPERATURA SUBE O BAJA UN GRADO CENTIGRADO O FARENHEIT CADA VEZ QUE EL BOTON MARCADO "UP" O "DOWN" ES EMPUJADO.
5. VERIFIQUE QUE LA FUENTE DE AGUA ESTE ABIERTA. EL AGUA ENTRARA AL MECANISMO DE HACER HIELO CUANDO LA UNIDAD ALCANCE LA TEMPERATURA APROPIADA.
6. LOS PRIMEROS CUBOS DE HIELO PODRIAN SALIR PEQUEÑOS DEBIDO AL AIRE EN LA ENTRADA DEL AGUA. LOS SIGUIENTES CUBOS TENDRAN EL TAMAÑO NORMAL EN FORMA DE MEDIA LUNA.
7. EL PRIMER CICLO TOMARA APROXIMADAMENTE 30-40 MINUTOS.
8. PARA LLENAR EL DEPOSITO SE REQUIEREN 140 ML DE AGUA Y APROXIMADAMENTE 11 HORAS.

IMPORTANTE: DESHAGASE DE LOS CUBOS DE HIELO HECHOS DURANTE LAS 3 PRIMERAS HORAS DE OPERACION.

- CUANDO EL DEPOSITO DE HIELO ESTE LLENO, EL MECANISMO PARA HACER HIELO SE DETIENE AUTOMATICAMENTE. SIN EMBARGO EL MOTOR CONTINUA ENFRIANDO Y MANTIENE LOS CUBOS DE HIELO CONGELADOS.
- PARA DETENER LA CAIDA DE CUBOS AL DEPOSITO, LEVANTE EL BRAZO DE METAL (DIBUJO 2).
- SI LA MAQUINA DE HACER HIELO NO ES USADA REGULARMENTE, RECOMENDAMOS QUE VACIE EL DEPOSITO DEL HIELO PERIODICAMENTE PARA ASEGURAR QUE TENGA HIELO FRESCO.
- A VECES LOS CUBOS PUEDEN SALIR BLANCOS O TURBIOS, ESTO ES NORMAL Y NO AFECTA EL SABOR O COMPOSICION DEL AGUA.
- LA REJILLA DELANTERA DEBE ESTAR LIBRE DE POLVO O PELUSAS PARA PERMITIR LA LIBRE CIRCULACION DEL AIRE.

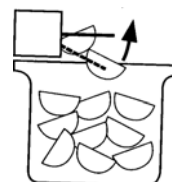

DIBUJO 2

## DESCONGELAMIENTO

EL SISTEMA LO HACE AUTOMATICAMENTE CADA 6 HORAS.

SI EL SISTEMA DE NO HACER ESCARCHA SE DESCOMPONE, APRIETE LOS 4 BOTONES SIMULTANEAMENTE Y SE ARREGLARA.

## COMO CAMBIAR LA DIRECCION DE APERTURA DE LA PUERTA

EN CASO DE QUE NECESITE CAMBIAR EL LADO DE APERTURA DE LA PUERTA, POR FAVOR CONSULTE AL SERVICIO POS-VENTA DE SU LOCALIDAD.

## USANDO SU MAQUINA DE HACER HIELO

### ADVERTENCIA

**NO USE AGUA HIRVIENDO PORQUE DAÑARA LAS PARTES DE PLASTICO. TAMPOCO USE PUNTAS O INSTRUMENTOS METALICOS PARA RETIRAR LA ESCARCHA YA QUE DAÑARA EL ESPIRAL DE ENFRIAMIENTO Y CANCELARA LA GARANTIA. LE RECOMENDAMOS USAR UNA ESPATULA DE PLASTICO.**

### CUIDADO Y MANTENIMIENTO

- **LIMPIANDO SU MAQUINA DE HACER HIELO**
- EMPUJE EL CONTROL A "OFF". DESCONECTE EL APARATO Y RETIRE LOS HIELOS.
- LAVE EL INTERIOR CON AGUA TIBIA Y UN PAÑO SUAVE REMOJADO EN UNA SOLUCION DE BICARBONATO DE SODIO. LA SOLUCION CONSISTE EN 2 CUCHARADAS DE BICARBONATO DE SODIO EN UN LITRO DE AGUA.
- LAVE LA CANASTA DE ALMACENAJE CON UN DETERGENTE SUAVE.
- LAS PARTES EXTERNAS DE SU MAQUINA DEBEN SER LIMPIADAS CON UN DETERGENTE SUAVE Y AGUA TIBIA.
- EL ESPIRAL DEL CONDENSADOR DEBE SER LIMPIADO CUANDO ESTE SUCIO O TENGA POLVO.

### ADVERTENCIA

**ASEGURESE DE DESCONECTAR LA MAQUINA DE HACER HIELO DE LA CORRIENTE ELECTRICA. SI NO LO HACE, PUEDE OCASIONAR UN CHOQUE ELECTRICO O HERIRSE.**

### SI FALLA EL SUMINISTRO ELECTRICO

USUALMENTE LA ELECTRICIDAD REGRESA EN UNAS POCAS HORAS SIN AFECTAR LA TEMPERATURA DE SU MAQUINA DE HACER HIELO, SIEMPRE QUE LA PUERTA NO SE ABRA MUY FRECUENTEMENTE. SI LE VA FALTAR ELECTRICIDAD POR UN PERIODO DE TIEMPO MAS LARGO, USTED DEBE TOMAR LOS PASOS APROPIADOS PARA PROTEGER SU ELECTRODOMESTICO.

### GUIA PARA SOLUCIONAR PROBLEMAS

PROBLEMA	SOLUCION
SU ELECTRODOMESTICO NO FUNCIONA	NO ESTA CONECTADO A LA CORRIENTE ELECTRICA. EL INTERRUPTOR SALTO O SE QUEMO UN FUSIBLE EL CONTROL ESTA EN "OFF"
NO HACE HIELO	EL CONTROL DE TEMPERATURA NO ESTA EN LA POSICION 5 ó 6.
EL COMPRESOR SE ENCIENDE Y SE APAGA FRECUENTEMENTE	LA TEMPERATURA DE LA HABITACION ES MAS CALIENTE DE LO NORMAL. LA PUERTA PERMANECE ABIERTA MUCHO TIEMPO. LA PUERTA NO QUEDO COMPLETAMENTE CERRADA. LA EMPAQUETADURA DE LA PUERTA NO ESTA SELLADA ADECUADAMENTE. LA MAQUINA DE HACER HIELO NO TIENE EL SUFICIENTE ESPACIO LIBRE. HAY MUCHA ESCARCHA. DESCONGELAR INMEDIATAMENTE.
VIBRACION.	ASEGURESE QUE LA MAQUINA DE HACER HIELO ESTE UBICADA EN UN LUGAR TOTALMENTE PLANO.
SONIDO DE BURBUJEO, GOTEO, COMO AGUA QUE HIERVE O CRUJIDOS.	ESTO ES NORMAL. ES EL REFRIGERANTE (USADO PARA ENFRIAR LA MAQUINA DE HACER HIELO) QUE ESTA CIRCULANDO A TRAVES DEL SISTEMA. LA CONTRACCION Y EXPANSION DE LAS PAREDES INTERNAS PUEDE OCASIONAR SONIDOS COMO CRUJIDOS.
LA PUERTA NO CIERRA COMPLETAMENTE	LA MAQUINA DE HACER HIELO NO ESTA TOTALMENTE NIVELADA. LA DIRECCION DE APERTURA DE LA PUERTA FUE INVERTIDA PERO INSTALADA INCORRECTAMENTE. EL SELLADOR DE LA PUERTA ESTA SUCIO. LA CANASTA DE ALMACENAJE ESTA FUERA DE SU SITIO OBSTACULIZANDO EL CIERRE DE LA PUERTA.

## REGISTRATION INFORMATION

THANK YOU FOR PURCHASING THIS FINE AVANTI PRODUCT. PLEASE FILL OUT THIS CARD AND RETURN IT WITHIN 100 DAYS OF PURCHASE TO RECEIVE THESE IMPORTANT BENEFITS AND RECEIVE THESE IMPORTANT BENEFITS TO THE FOLLOWING ADDRESS:

**AVANTI PRODUCTS, A DIVISION OF THE MACKLE CO., INC.**  
**P.O. BOX 520604 - MIAMI, FLORIDA 33152 USA**

➤ **PROTECT YOUR PRODUCT:**

WE WILL KEEP THE MODEL NUMBER AND DATE OF PURCHASE OF YOUR NEW AVANTI PRODUCT ON FILE TO HELP YOU REFER TO THIS INFORMATION IN THE EVENT OF AN INSURANCE CLAIM SUCH AS FIRE OR THEFT.

➤ **PROMOTE BETTER PRODUCTS:**

WE VALUE YOUR INPUT. YOUR RESPONSES WILL HELP US DEVELOP PRODUCTS DESIGNED TO BEST MEET YOUR FUTURE NEEDS.

------(DETACH HERE)-----

### AVANTI REGISTRATION CARD

NAME \_\_\_\_\_

MODEL # \_\_\_\_\_ SERIAL # \_\_\_\_\_

ADDRESS \_\_\_\_\_

DATE PURCHASED \_\_\_\_\_ STORE/DEALER NAME \_\_\_\_\_

CITY \_\_\_\_\_ STATE \_\_\_\_\_ ZIP \_\_\_\_\_

OCCUPATION \_\_\_\_\_

AREA CODE \_\_\_\_\_ PHONE NUMBER \_\_\_\_\_

**AS YOUR PRIMARY RESIDENCE, DO YOU:**

OWN  RENT

**DID YOU PURCHASE AN ADDITIONAL WARRANTY:**

EXTENDED  FOOD LOSS  NONE

**REASON FOR CHOOSING THIS AVANTI PRODUCT:**

PLEASE INDICATE THE MOST IMPORTANT FACTORS THAT INFLUENCED YOUR DECISION TO PURCHASE THIS PRODUCT.

- PRICE  
 PRODUCT FEATURES  
 AVANTI REPUTATION  
 PRODUCT QUALITY  
 SALESPERSON RECOMMENDATION  
 FRIEND/RELATIVE RECOMMENDATION  
 WARRANTY  
 OTHER \_\_\_\_\_

**YOUR AGE:**

UNDER 18  18-25  26-30  
 31-35  36-50  OVER 50

**MARITAL STATUS:**

MARRIED  SINGLE

**IS THIS PRODUCT USED IN THE:**

HOME  BUSINESS

**HOW DID YOU LEARN ABOUT THIS PRODUCT:**

ADVERTISING  
 IN STORE DEMO  PERSONAL DEMO  
 OTHER \_\_\_\_\_

COMMENTS \_\_\_\_\_

**PRINTED IN CHINA**

## Free Manuals Download Website

<http://myh66.com>

<http://usermanuals.us>

<http://www.somanuals.com>

<http://www.4manuals.cc>

<http://www.manual-lib.com>

<http://www.404manual.com>

<http://www.luxmanual.com>

<http://aubethermostatmanual.com>

Golf course search by state

<http://golfingnear.com>

Email search by domain

<http://emailbydomain.com>

Auto manuals search

<http://auto.somanuals.com>

TV manuals search

<http://tv.somanuals.com>