



Electro-Sealer

7112 HF

AVERY DENNISON

Manual Edition 3.1

10 August 2004

Manual Part Number 701395

This page left blank intentionally.

Contents

Warranty Information	1
Limited Warranty.....	1
Parts.....	1
Service.....	1
Safety Instructions	2
Warning.....	2
Model 7112 Hopper Feed Heat Sealer	3
Unit Specification.....	4
Installation	5
To Change Time Settings.....	5
General Description	7
Main Switch.....	7
Auto Switch.....	7
Vacuum On Off Switch.....	7
Load Push Button Switch.....	7
Feed Push Button Switch.....	7
Air Pressure Gauge / Regulator.....	7
Heat Controls.....	7
Basic Sealing.....	8
Leveling the Press.....	9
Operation	10
Setting the Controls.....	10
Security Level Selection.....	12
Password Table.....	12
Regular Maintenance	13
7112 Series Hopper Feed.....	13
Trouble Shooting.....	14
Sealing Problems.....	16
Electrical Drawings	17
Electrical Schematic – Part 1.....	18
Electrical Schematic – Part 2.....	19
Electrical Schematic – Part 3.....	20

Electrical Schematic – Part 4	21
Pneumatic Drawings	22
Pneumatic Schematic	23
Assembly Drawings	25
Front Panel Assembly Drawing and Cover	26
Front Panel Parts List	27
Frame and Cover Assembly Drawing	28
Frame and Cover Parts List	29
Main Cylinder & Cabinet Assembly Drawing	30
Main Cylinder & Cabinet Parts List	31
Main Cylinder / Platen Assembly Drawing	32
Main Cylinder / Platen Parts List	33
Swing Arm & Base Plate Assembly Drawing	34
Swing Arm & Base Plate Parts List	35
Manifold Assembly Drawing	36
Manifold Parts List	37
Vacuum & Regulator Assembly Drawing	38
Vacuum & Regulator Parts List	39
2” Hopper Feed Assembly Drawing	40
2” Hopper Feed Parts List	41
3” Hopper Feed Assembly Drawing	42
3” Hopper Feed Parts List	43

Warranty Information

Limited Warranty

AVERY DENNISON extends the following warranties to the original purchaser of a AVERY DENNISON Electro-Sealer that has been installed and operated using recommended procedures and operating conditions.

Parts

Parts found defective in material or workmanship will be replaced at no charge for a period of six months following the machine's shipment date. Parts damaged by negligence, abuse, or normal wear are not covered. AVERY DENNISON Electro-Sealer parts classed as normal wear items include vacuum cups, Teflon® tape and rubber pads

Service

Service to replace defective parts as defined above, shall be provided at no charge for a period of six months following the shipment date.

When ordering machines and supplies in the U.S.A., reference all correspondence to the address below.

AVERY DENNISON
One Wilcox Street
Sayre, Pa. 18840
Call: 1-800-967-2927 or (570) 888-6641
Fax: (570) 888-5230

For spare parts, requests for service or technical support

AVERY DENNISON
One Wilcox Street
Sayre, Pa. 18840
Call: 1-800-967-2927 or (570) 888-6641
Fax: (570) 888-5230

For parts and service in other countries please contact your local AVERY DENNISON supplier.

AVERY DENNISON reserves the right to incorporate any modifications or improvements in the machine system and machine specifications which it considers necessary and does not assume any obligation to make said changes in equipment previously sold.

Safety Instructions

Warning

When using electric tools, basic safety precautions should always be followed to reduce the risk of fire, electric shock, and personal injury. Failure to follow these instructions can result in severe personal injury.

READ ALL INSTRUCTIONS CAREFULLY!

The importance of using safe operating procedures cannot be over emphasized. The following guidelines will assist you in safe operations.

1. Read all warning labels and heed their instructions during installation and operation.
2. Use proper line voltage (110 VAC) and air pressure (80 / PSI air pressure) as outlined.
3. Keep hands clear of pinch points during operation and do not touch any of the heated plates while loading or unloading garments.
4. Do not remove any guards. Guards must be in place during operation.
5. Use only an authorized person to service machine and be sure all power sources (Air and electrical) are disconnected during service.
6. Do not attempt to circumvent safety features.

Adherence to these instructions will prevent injury to personnel and with care and normal maintenance the equipment will provide many years of service.

Model 7112 Hopper Feed Heat Sealer

The 7112 HF Sealer has been designed to automate the feeding of labels, flocks and stackable embroideries. Precision and versatility have been the keynotes of its design.

Precision in that each item can be repeatedly fed to 1/32 of an inch in position. Versatility in that the system can feed one item at a time or two at once. This provides the means by which a garment that needs two labels can be labeled with one stroke of the press. Thus providing twice the production capability for the cycle time.

A further option that is available is the reciprocal base system, which will automatically position garment items under the press head. This feature makes it possible to load and unload garments prior to actual sealing.

The installation is covered in the following section.

Unit Specification

Physical Size

W 17" X D 17" X H 28"

Weight

100LBS

Air Consumption

5 CFM

Electrical Use

120 V – 15 AMP AC

Transfer Size Max

3" X 3"

Top Heat

Max – 550 °F

Bottom Heat

Max – 550 °F

Pressure Max

125 PSI

Dwell Time

Electronically adjustable

Head Stroke

2.5"/63.5mm

Power Consumption

1200 Watts

Temperature

41°F/5°C to 104°F/40°C

Humidity

5% to 90% non-condensing

Installation

1. Place machine on solid table.
2. Connect compressed air service of 80 PSI to air regulator input.
3. Put main plug into source of a current AC 120 VAC @ 15 Amps.
4. Turn on main switch.
5. Fill hopper with labels/transfers (For labels, adhesive side down)
6. Press Load Button, vacuum cup should pick up label from hopper. Press the Feed Button to move the label/transfer from the hopper to the Electrode Plate (Sealing head). If cup does not pick up label:
 - A) Check position of hopper and adjust so that vacuum cup touches labels on edge of label covered with adhesive providing good suction.
 - B) The number on the vacuum gauge should read 16 or higher with label on cup.
7. With a label/transfer under the sealing head, activate the hand switches. Head should now descend - putting label/transfer on shirt with the pressure shown on air gauge
8. Leveling of the press should be checked to determine that the sealing head is parallel to the base. This can be checked by sealing a carbon paper order form in the machine. This should show a nice even pressure picture. An uneven condition can be adjusted with the bolt in the rear of the base plate.

To Change Time Settings

1. To begin sequence press "OK".
2. Press cursor knob arrow down ↓ (The word "Parameter" will appear).
3. Press "OK".
4. T-1 will be flashing on right side
5. Press cursor knob left ←.
6. Use cursor knob up ↑ or down ↓ to change to desired time setting.
7. Press "OK".
8. Press "ESCAPE" twice.

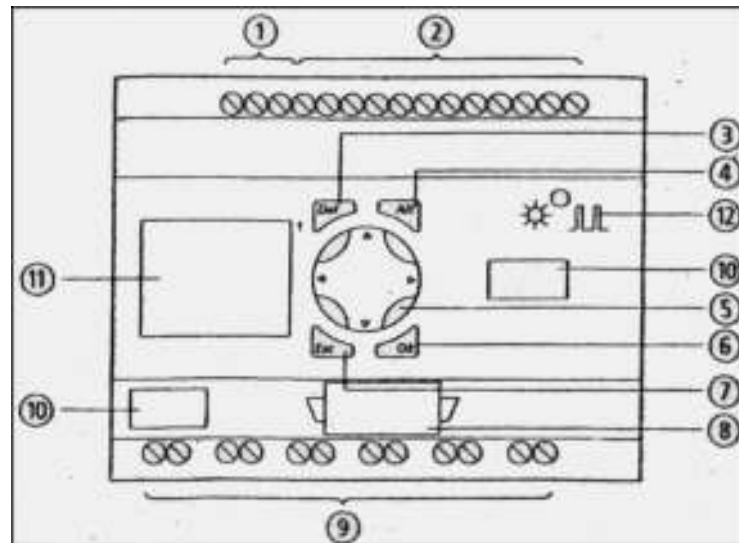

1	Voltage Supply - 1760-L18AWA 85 to 264 V ac 50/60 Hz	7	Esc button - One menu back - Exit function relay parameter menu without saving
2	Inputs - 1760-L18AWA 12 inputs 0 to 264 V ac	8	Interface (with cover) - Slot for memory card - Socket for PC interface cable
3	Del button - Delete contacts/relays/connections/empty rung	9	Outputs - Write-on surface
4	Alt button - Draw connection - Toggle between make or break contact - Insert rung	10	
5	Cursor buttons: right, left, up, down - Select contact, relays, numbers P button on: Input P1 -> Cursor left Input P2 -> Cursor up Input P3 -> Cursor right Input P4 -> Cursor down	11	LCD - I/O status display - Operating states - Circuit diagram - Display of clock
6	OK button - Enter menu - Accept action	12	Power / Run LED

General Description

Main Switch

This turns the machine on and off.

Auto Switch

Turning this switch to the "on" position will activate the feed system, transporting a label from the hopper to underneath the electrode, ready for sealing.

Vacuum On Off Switch

Turn the vacuum generator **on** and **off**

Load Push Button Switch

Load a label from the hopper via vacuum to the feed arm vacuum block.

Feed Push Button Switch

Feed the label from the hopper position to the upper platen position for the sealing cycle.

Air Pressure Gauge / Regulator

Adjustment of air pressure is accomplished by turning the knob under the air pressure gauge. To raise the pressure, turn the knob clockwise; to lower, turn it counter-clockwise. When lowering the pressure, allow the needle on the gauge to drop below the desired pressure, and then raise it back to that pressure. The reason for this is that there is a lag when bleeding air out of the system.

Heat Controls

Electrode and plate head can be set independently. The correct temperature will be indicated on the control's face. If the control fails to reach this, refer to the heat control pages provided.

Basic Sealing

Heat, dwell time, and pressure are the basic fundamentals that determine the results obtainable on a thermo-plastic sealing application, such as Electro-Seal labeling. It is impossible with the variety of fabric materials and constructions, as well as design of garments, to establish any one setting that will give the most desirable results under all circumstances. ON THE BASIS OF EXTENSIVE SUCCESSFUL LAUNDRY TESTS, ON AVERAGE WEIGHT GOODS INVOLVING BOTH WOVEN AND KNIT MATERIALS, WE WOULD SUGGEST THE FOLLOWING STARTING POINTS FOR A NEW ELECTRO-SEAL USER;

- Setting the plate heat at 400°F has proven to be a good starting point. Setting the electrode heat will depend on the type of adhesive being used. A cycle time of 1 1/2 - 2 seconds for average weight fabrics and labels has proven adequate for laundry proof attachment.

Remember...these are only basics, and these settings can vary. Seal a label to a sample. As your Electro-Sealer times out and releases itself, immediately remove the fabric and lift the corner of the label. If the adhesive has stuck to both the fabric and the label, the sealing can be judged successful. If all the adhesive is on the fabric and none on the label, decrease the plate heat or cut back the time. Adhesives tend to flow toward the heat.

If the adhesive has not transferred to the fabric, you have three adjustments that can be made:

- A. Increase the plate heat**
- B. Decrease the electrode heat**; thermoplastics tend to flow towards higher heat when melting.
- C. Increase the cycle time** to allow complete melting.

If the adhesive has all transferred to the fabric with none left on the label, you may:

- A. Reduce the plate heat**
- B. Decrease the cycle time**

You must judge for yourself, depending on the fabric's sensitivity to heat and time, which of the adjustments will be best.

Leveling the Press

1. With the heat on, set the dwell timer for one (1) second or less; put a light colored cloth or paper on the base plate (bottom platen); then, put a piece of carbon paper, carbon side down. Run the machine through a cycle. The carbon paper will leave a picture of sealing area on the cloth or paper. THE COLOR SHOULD BE EVEN. A dark area indicates more pressure in that area and should be corrected.
2. If the out of level condition is in either the front or back, the base plate can be tilted.
3. Loosen the bolt to lower front and raise the back.
4. Tighten to raise the front, lower the back (see fig below)

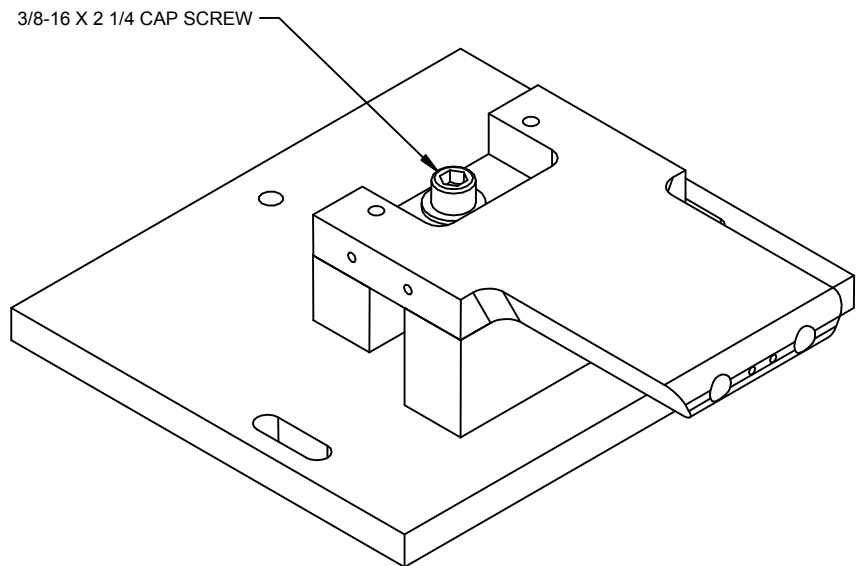

Operation

To put your Electro-Sealer into operation, turn on the main switch. Set the plate and electrode heat controls to the desired temperature. Turn on the vacuum pump by using the switch located on the power cord for the pump.

Turn on the auto switch. This will cause the vacuum arm to pull a label from the hopper and move it into position until the operator depresses the foot pedal, sealing the label onto the garment. The pedal must be held down until the press cycles out and the seal is completed. As the press starts to rise from the garment, the foot pedal can be released, which resets the vacuum arm to feed another label. In doing this, the machine automatically feeds another label while the operator is removing the garment and inserting another.

When the label has been fed into position for sealing, it is important that the label is totally under the electrode so that the pressure is exerted on the adhesive coated label.

The position of the vacuum arm is always the same and so to change the position of the label relative to the electrode, you must change the position where the hopper places the label on the vacuum arm. To move the label left or right, the hopper is moved by loosening the lower hopper bracket, shifting the hopper in the direction desired, then tightening the bracket in position.

Setting the Controls





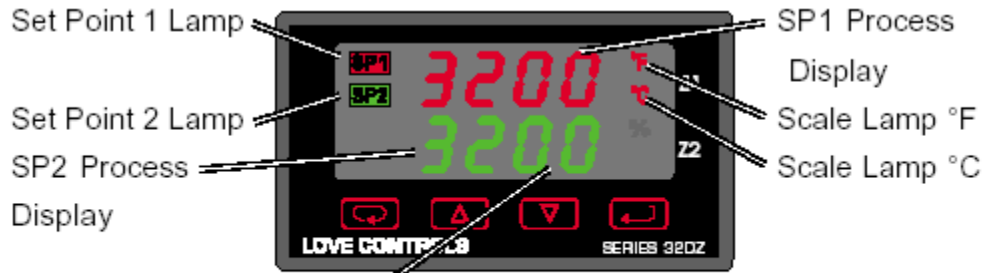

Heat dwell time, and pressure are the basic fundamentals that determine the results obtainable on a thermoplastic sealing application. It is impossible with the variety of fabric material and constructions, as well as design of garments, to establish any one setting that will give you the most desirable results under all circumstance, but settings will be suggested upon request and submission of an application.

- 1) Set the heat electrode (Top platen) and base plate (Bottom platen) to the desired temperature (See heat control section).
- 2) Turn auto switch to the on position
- 3) Set dwell time recommended by the transfer manufacturer



The decimal point flashes when Self-Tune is operating.

Keys are illuminated when pressed. Key functions are as follows:

-  **INDEX:** Pressing the INDEX key advances the display to the next menu item. May also be used in conjunction with other keys as noted below.
-  **UP ARROW:** Increments a value, changes a menu item, or selects the item to ON. The maximum value obtainable is 9999 regardless of decimal point placement.
-  **DOWN ARROW:** Decrements a value, changes a menu item, or selects the item to OFF. The minimum value obtainable is -1999 regardless of decimal point placement.
-  **ENTER:** Pressing ENTER stores the value or the item changed. If not pressed, the previously stored value or item will be retained. The display will flash once when ENTER is pressed.
-  **UP ARROW & ENTER:** Pressing these keys simultaneously brings up the secondary menu starting at the alarm, tune, or cycle item (depending on programming). Pressing these keys for 5 seconds will bring up the secure menu.
-  **INDEX & DOWN ARROW:** Pressing these keys simultaneously will allow backing up one menu item, or if at the first menu item they will cause the display to return to the primary menu. If an alarm condition has occurred, these keys may be used to reset the alarm.
-  **INDEX & ENTER:** Pressing these keys simultaneously and holding them for 5 seconds allows recovery from the various error messages. The following menu items will be reset:

OPEn InP: Input error message **bAd InP:** Input error message



CHEC CAL: Check calibration error

Correct the problems associated with the above conditions before using these reset keys. More than one error could be present. Caution is advised since several items are reset at one time.

While in the **Primary or Secondary Menu**, if no key is pressed for a period of 30 seconds, the display will return to the HOME position displaying the temperature value. While in the **Secure Menu**, if no key is pressed for a period of 60 seconds, the display will return to the HOME position displaying the temperature value. Outputs are disabled (turned off) when the **Secure Menu** is active.

NOTE: To move to the **Primary Menu** quickly from any other menu, press the **UP ARROW & ENTER** keys followed by pressing the **INDEX & DOWN ARROW** keys.

Security Level Selection

Four levels of security are provided. The display shows the current security level. To change security levels change the password value using the  **UP ARROW** and  **DOWN ARROW** keys and pressing the  **ENTER** key. Refer to the password table (following) for the correct value to enter for the security level desired. The **SEC1** or **SEC2** menu items security level may be viewed or changed at any time regardless of the present security level.

To set the access level to, for example, **2**, at the **SEC1** menu item press the  **UP ARROW** key until the upper display shows the password, **1101**.

Press the  **ENTER** key. The display will blink, and return with the level value, **2**, in the upper display.

The password values shown in the table cannot be altered, so retain a copy of these pages for future reference. This is the only reference made to password values in this instruction book.

Password Table

Menu	Security Level Status	Displayed Value When Viewed	Password Value To Enter
Primary Secondary Secure	Locked Locked Locked	1	1110
Primary Secondary Secure	Unlocked Locked Locked	2	1101
Primary Secondary Secure	Unlocked Unlocked Locked	3	1011
Primary Secondary Secure	Unlocked Unlocked Unlocked	4	111

Regular Maintenance

7112 Series Hopper Feed

1. Remove accumulated moisture from the air filter by opening the bleed valve located at the base of the filter bowl.
2. To check the sealing area for an out of parallel condition: with the heat on, set the timer for one (1) second or less; place a light colored cloth or paper on the base plate; put a piece of carbon paper, carbon down on the cloth, and run the machine through a cycle. The carbon paper will leave a picture of the sealing area on the cloth. THE COLOR SHOULD BE EVEN. A dark area indicates more pressure in that area and should be corrected.
3. If the out of level condition is either in the front or back, the base plate can be tilted. Loosen the bolt to lower the front and raise the back. Tighten to raise the front, lower the back.
4. If it is side to side, it must be corrected with shims placed under the base plate insulator block.
5. Light or dark spots within the sealing area will indicate that either of the plates may be warped. This would require surface grinding by a machine shop. (Make certain that the vacuum arm does not extend lower than the electrode.)
6. Lubricate the head assembly guide pin monthly with white grease.
7. Lubricate the feed arm shaft and rack with light oil, a FEW drops weekly.
8. The Teflon® composition covers on the electrode and base plate must be changed as frequency of use dictates. They provide a non-stick surface, which can be wiped clean with a cloth.
9. Check the vacuum filters monthly and clean or replace as required.

Trouble Shooting

Symptoms	Probable Cause	Corrective Action
Timer does not move but press operates	Hold Switch turned on.	Hold Switch should be turned off.
	Defective timer.	Replace timer.
No heat / no movements	Bad fuse.	Check and / or replace fuse.
	No power.	Check power to its source.
Timer moves / heat works	Lack of air pressure	Check main airline.
No movement	Binding cylinder	Disconnect main air line, attempt to move cylinder by hand, loosen air line from 4-way valve to TOP of cylinder; operate machine. If not, replace valve. If air escapes, tighten and check line to the BOTTOM of cylinder.
	Bad 4-way valve	
No heat / no indicator light, no meter indicator	No power	Check wiring
No heat / no indicator light. Meter reads +50	Bad probe	Replace probe.
Heat out of control	Unit malfunctions.	Replace Unit
	Probe shorted.	Replace probe.
Heat working, meter not in the green band	Error in manual reset control	Reset according to Athens Booklet.
Air leak at 4-way valve exhaust	Internal leak in cylinder	Replace or rebuild cylinder
	Jammed 4-way valve	Replace 4-way valve
Timer will not reset	Reset switch not functioning	Adjust or replace
Vacuum arm stays in the down position	a) Foot pedal not held down until timer hits zero	1) Hold down until timer hits zero
	b) Hold Switch turned on	2) Hold Switch must be off during normal operation.
	c) Timer malfunction	3) Replace timer
	d) 4-way valve jammed	4) Replace 4-way valve
Vacuum arm stays in up position after cycle	Reset Switch not functioning	Replace or adjust
Vacuum arm has no tension	Broken tension spring	Replace
	Broken gear teeth	

Symptoms	Probable Cause	Corrective Action
Vacuum arm moves too fast or too slow	Flow controls out of adjustment	Adjust for smooth motion, not too fast
Vacuum arm does not go to ready position when auto switch is activated	Relay not working Switch not working	Replace
Will not pull label out of hopper	Vacuum pump off. Poor vacuum. Too much weight in hopper. Vacuum holes in the arm not covered by label	Check and adjust
Labels feed on bias	Poor vacuum Hopper out of adjustment	Increase tension on bleed valve. Adjust.
Feeds two labels at one time	Too much vacuum	Decrease tension on bleed valve. Thumb stack before loading into hopper.

Sealing Problems

Symptoms	Probable Cause	Corrective Action
Uneven sealing of label.	Machine out of level; plates not parallel.	Check and Adjust
	Hitting a seam or button with electrode.	Relocate the label or use smallest electrode possible.
	Uneven thickness in label. Cardboard in garment.	Use silicone rubber to level.
Shining of sealing area.	Heat and / or pressure	Reduce heat and / or dissipate pressure using silicone rubber.
		Shorten time.
		Needle board.
Crushing of fabrics.	Too much air pressure.	Reduce or dissipate.
	High pile or napped material.	Use an electrode that matches the item being sealed.

Electrical Drawings

Electrical Schematic – Part 1

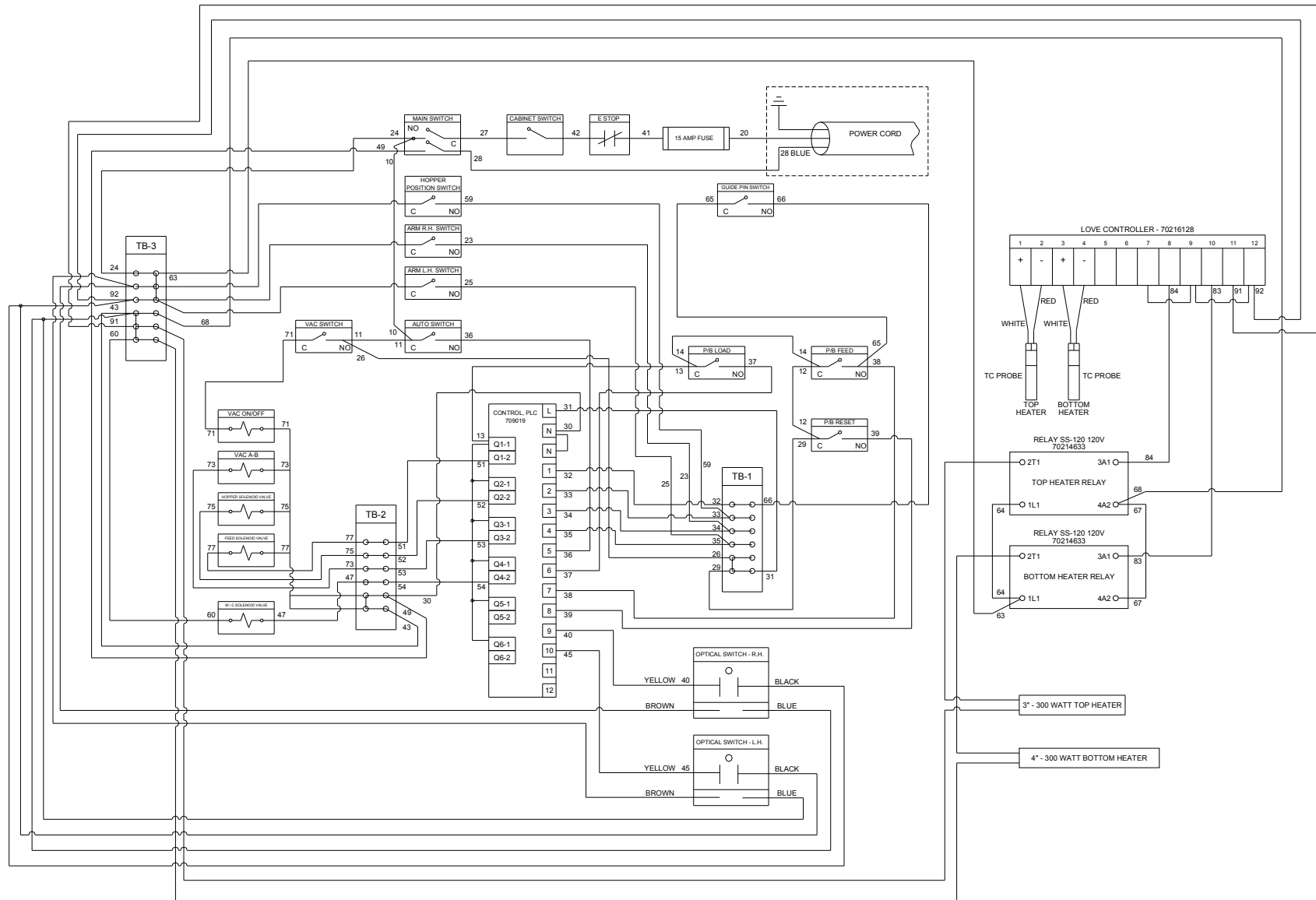

Electrical Schematic – Part 2

7112 HF 1-3

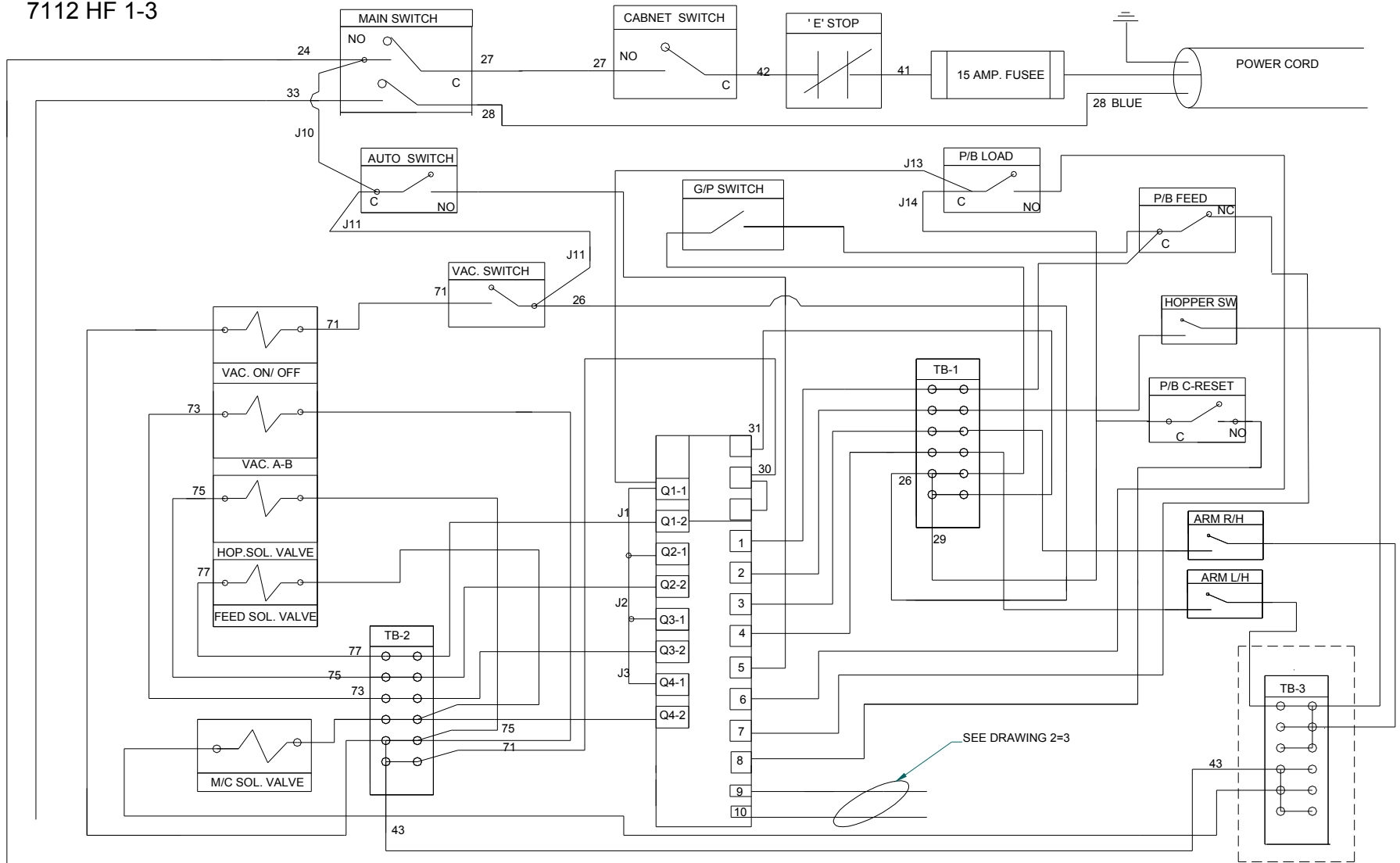

Electrical Schematic – Part 3

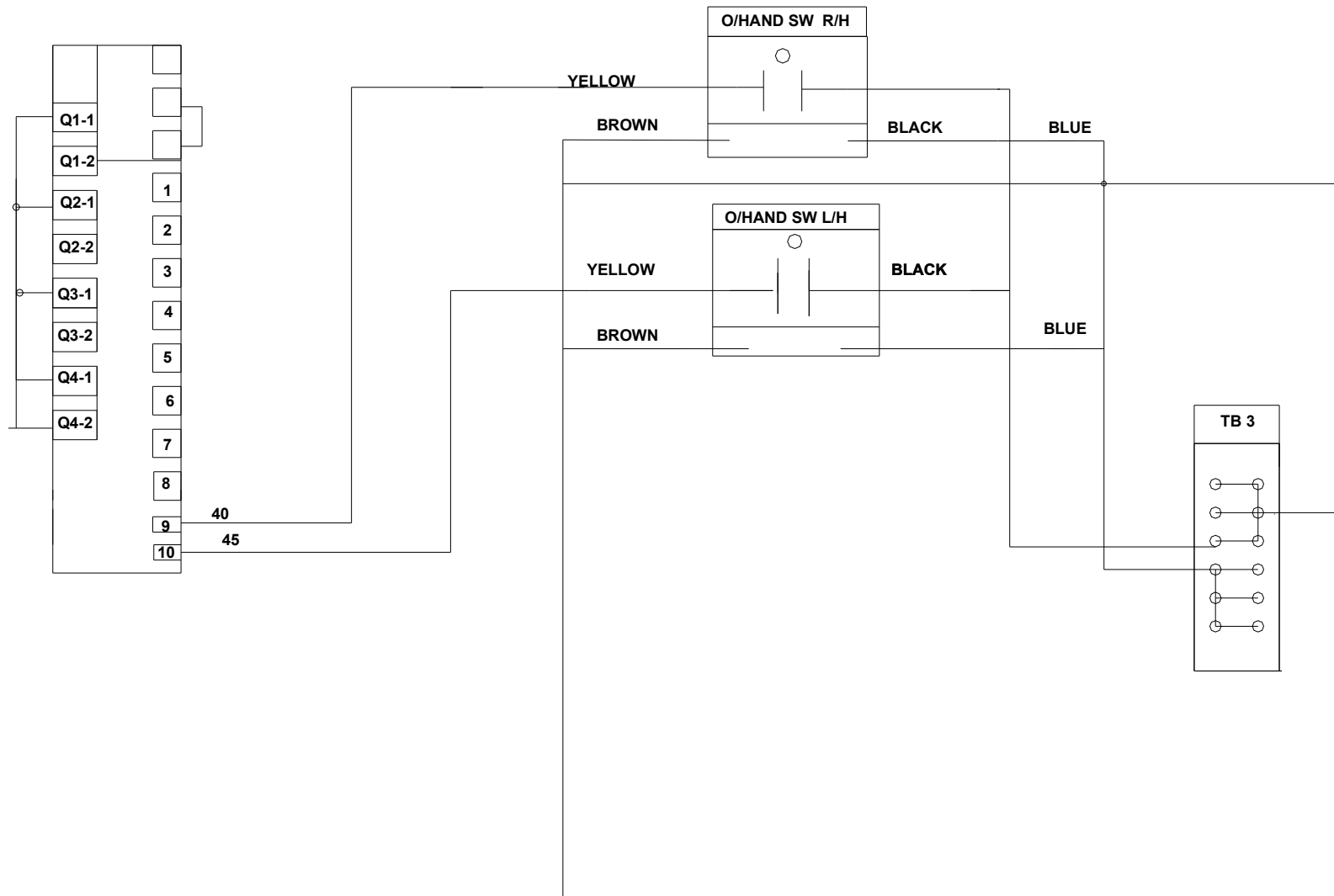

Electrical Schematic – Part 4

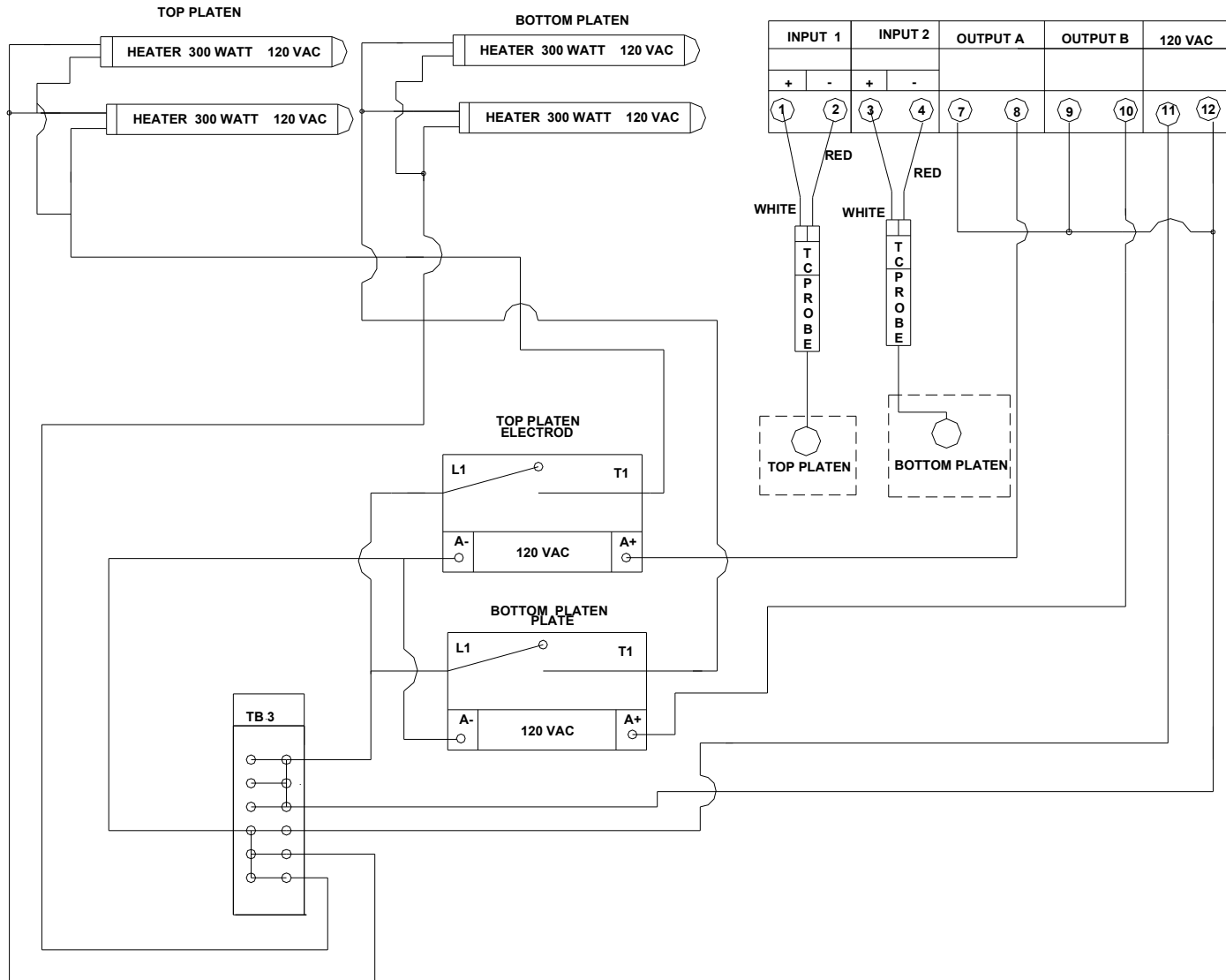

Pneumatic Drawings

Pneumatic Schematic

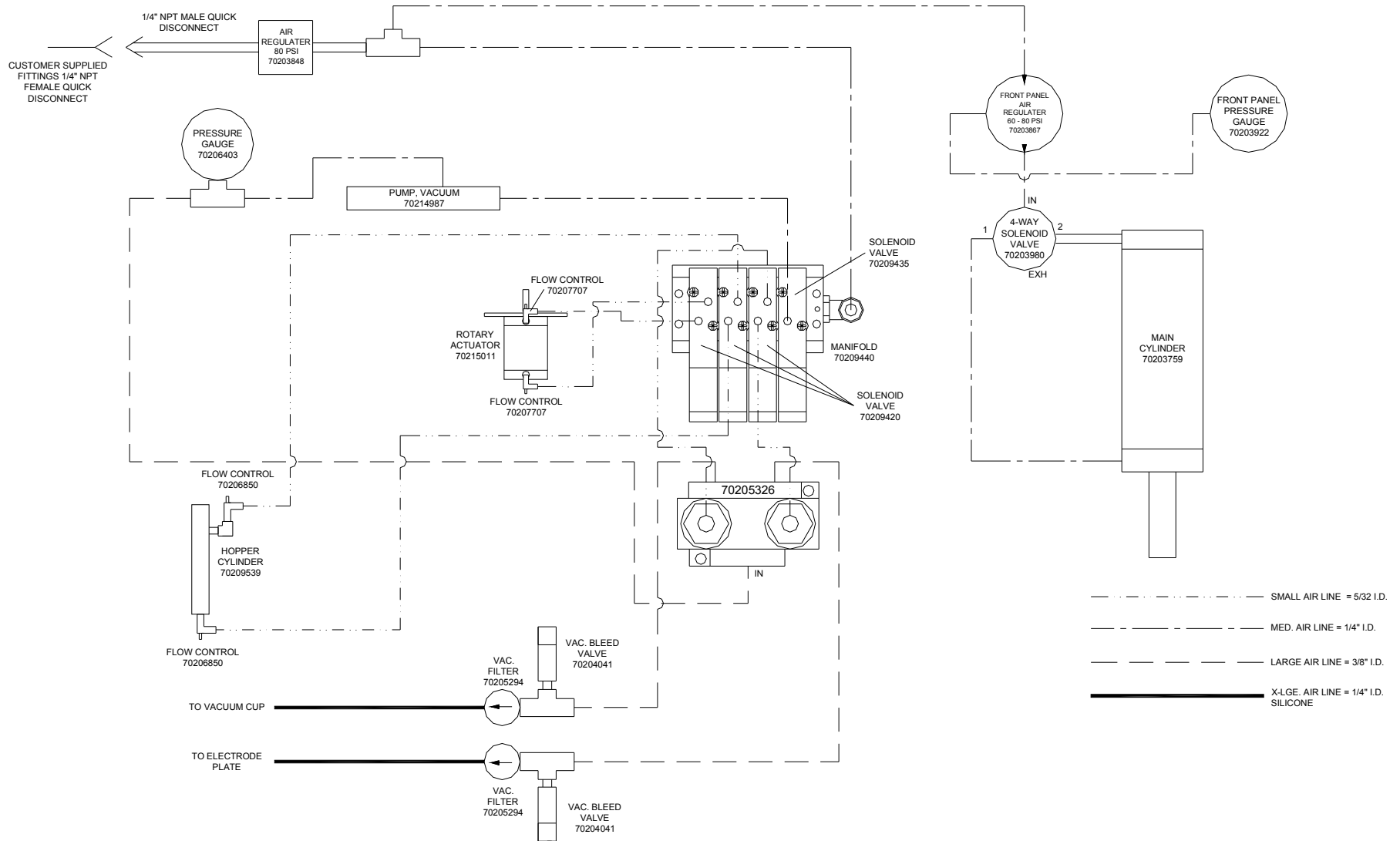

Assembly Drawings

Front Panel Assembly Drawing and Cover

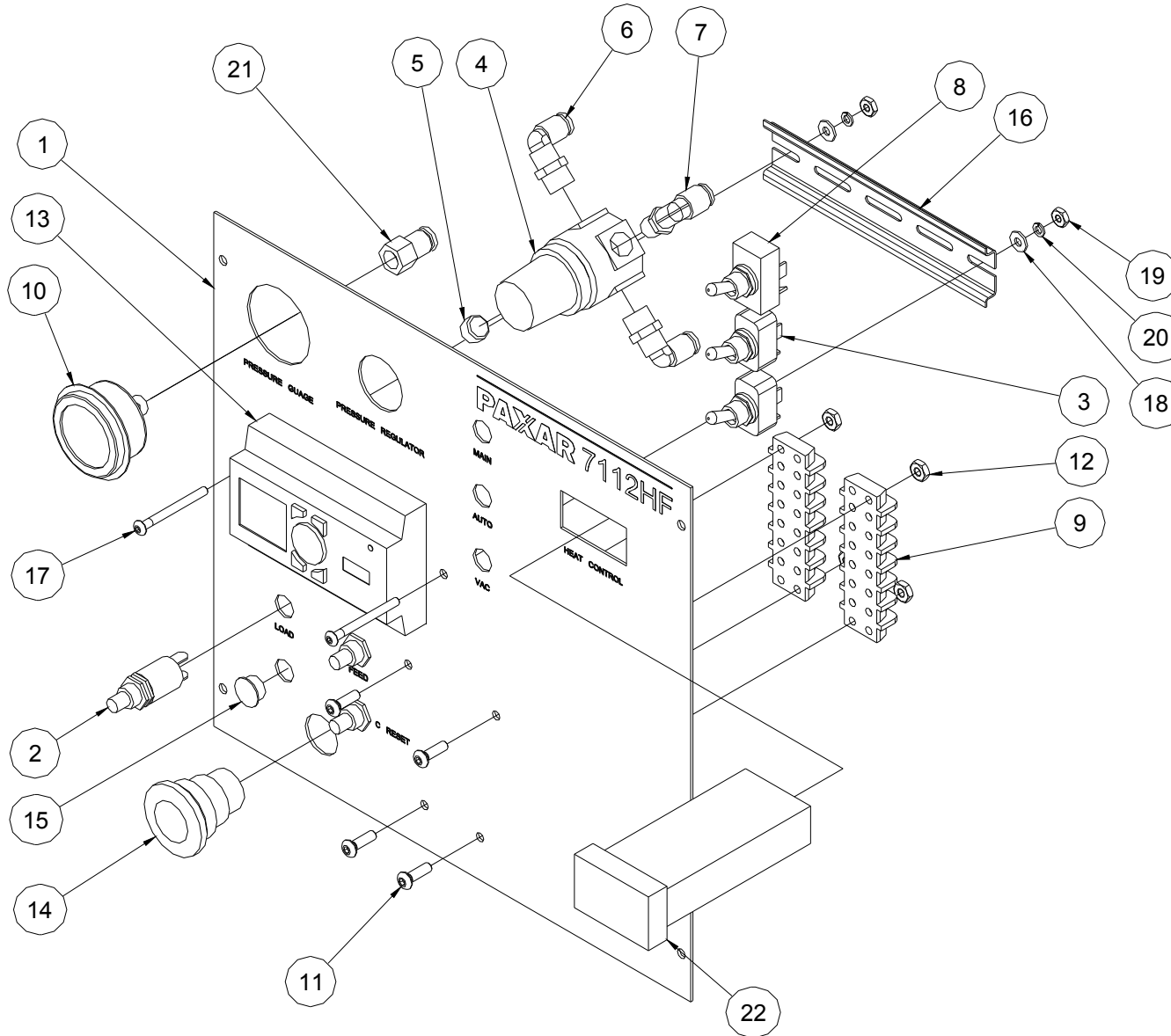

Front Panel Parts List

Item	Part #	Description	Qty
1	70207035	Cover, Front panel, 7112HF	1
2	70200568	Switch, Knife / Load (Norm open)	3
3	70200746	Switch, Main SPST Hold / Auto / Vac	2
4	70203922	Regulator, (Panel mount, No gauge)	1
5	361129	1/8 NPT Hex socket plug	1
6	708003	1/4 NPT x 1/4 tube x 90deg swivel elbow	2
7	708009	1/8npt x 1/4 tube x 90deg swivel elbow	1
8	70200712	Toggle switch, DPST	1
9	70200750	Terminal strip, 6 Position	2
10	70203867	Gauge, Air pressure, 1 1/2 in	1
11	991107	10-32 x 5/8 Button head screw	4

Item	Part #	Description	Qty
12	990103	Hex nut, #10	4
13	709019	Control, PLC	1
14	709018	Button, E-stop	1
15	990419	Plug, 1/2 Inch hole	1
16	709023	Din rail, Controller, 7112HF	1
17	991401	8-32 x 1 3/4 Button head screw	2
18	990067	Washer, #8 SAE	2
19	990069	Hex nut, 8-32	2
20	990068	Washer, #8 lock	2
21	708038	1/8 NPT x 1/4 Tube straight female fitting	1
22	70216128	Heat control, Love (32 DIN)	1

Frame and Cover Assembly Drawing

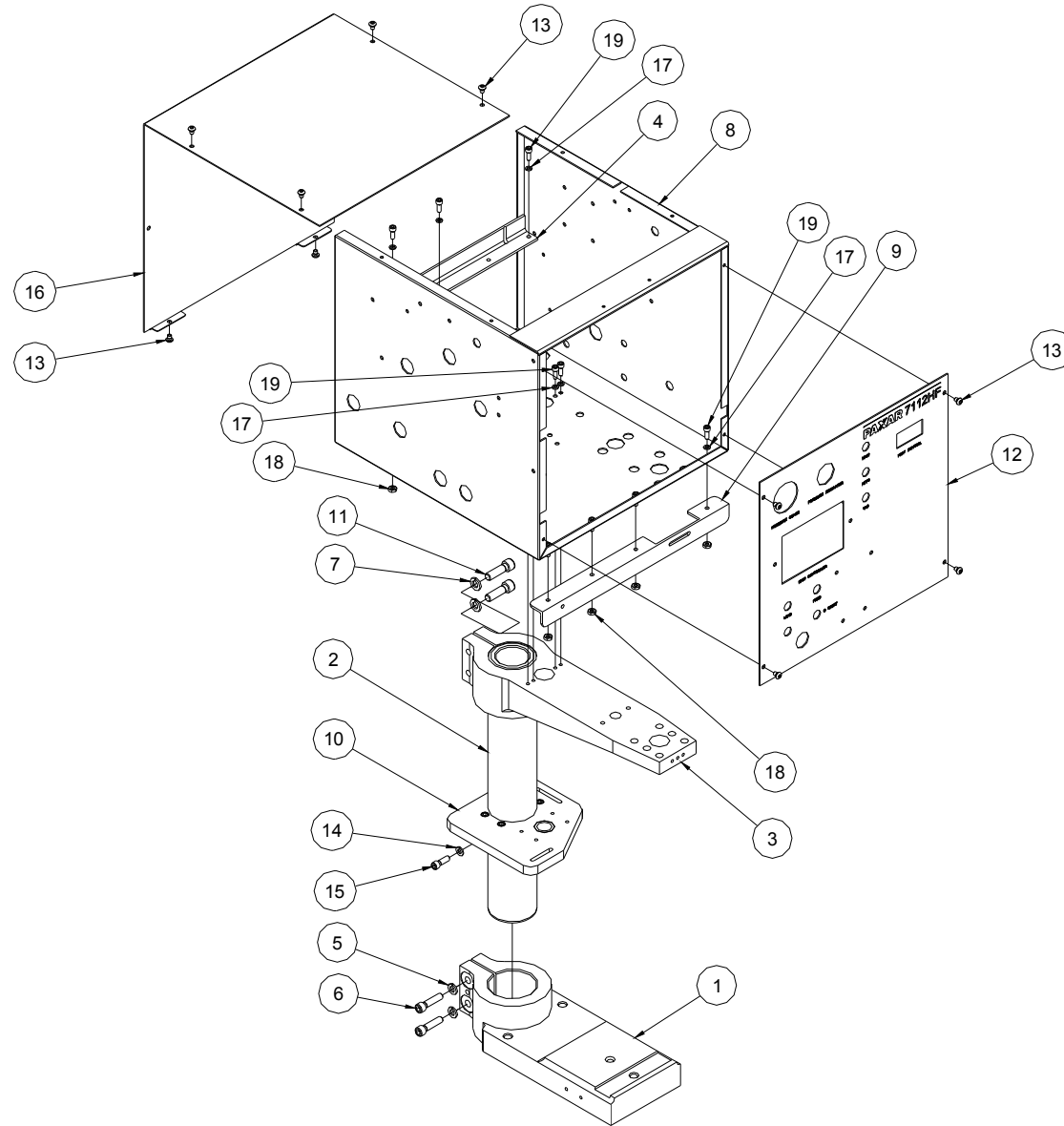

Frame and Cover Parts List

Item	Part #	Description	Qty
1	70209100	Casting base, 12 Inch	1
2	70201908	Column support, 15 Inch	1
3	70207092	Casting Overarm	1
4	70207336	Support, Cabinet rear, 7112HF	1
5	990181	Washer, 5/16 Lock	2
6	990172	5/16-18 x 1 1/4 Cap screw	2
7	990208	Washer, 3/8 Lock	2
8	70207041	Cover, Cab wrap around, Offset	1
9	70207745	Support, Cabinet front, 7112HF	1
10	70207567	Ass'y, Feed arm plate	1

Item	Part #	Description	Qty
11	991400	3/8-16 x 1 1/4 Cap screw	2
12	70207035	Front panel, 7112HF	1
13	990089	10-32 x 1/4 Button head screw	10
14	990145	Washer, 1/4 Lock	2
15	990122	1/4-20 x 3/4 Cap screw	2
16	70201575	Cover, Cab rear with hinge	1
17	990728	Washer, #10 Lock	12
18	990103	Hex nut, #10	8
19	990081	10-32 x 1/2 Cap screw	12

Main Cylinder & Cabinet Assembly Drawing

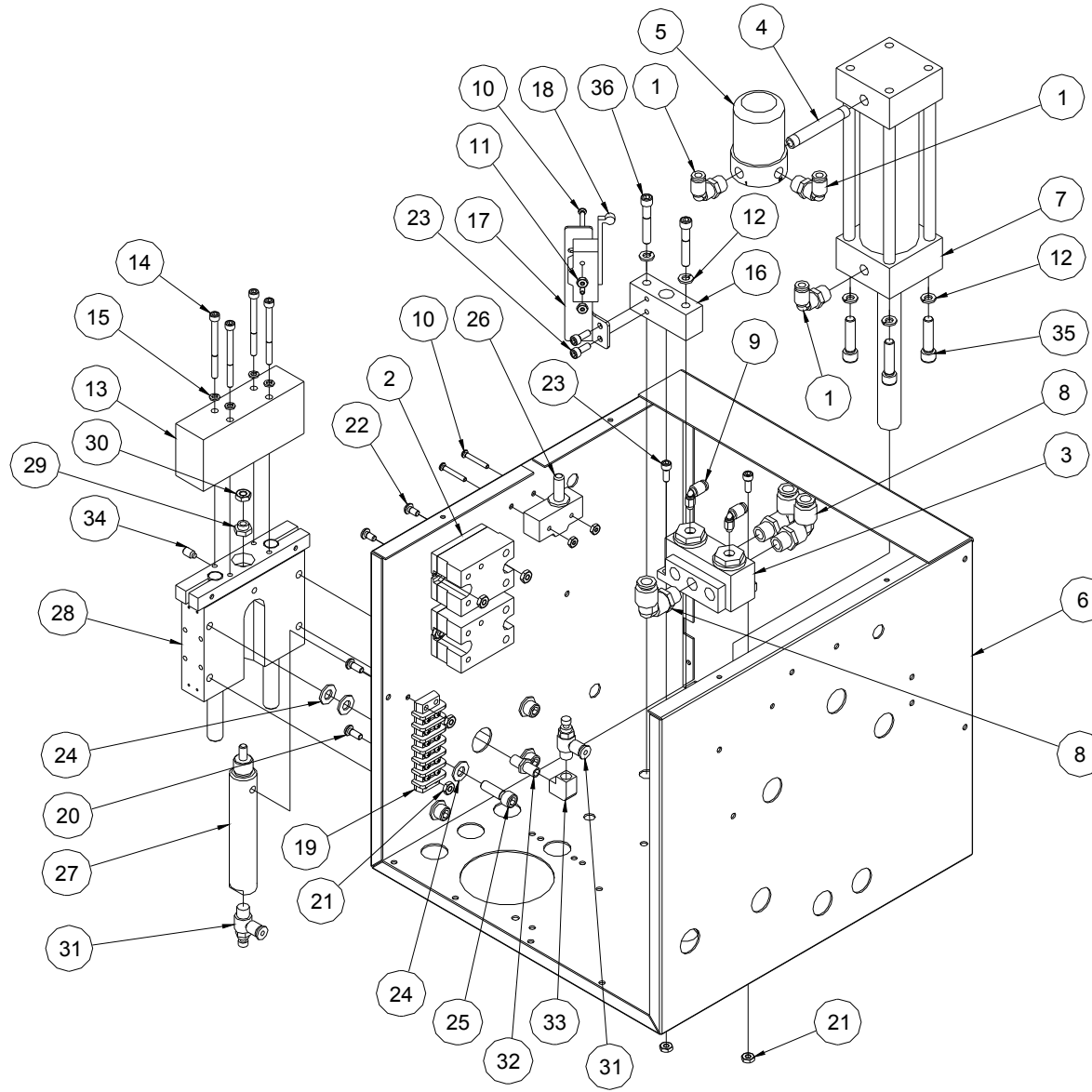

Main Cylinder & Cabinet Parts List

Item	Part #	Description	Qty
1	708003	1/4NPT x 1/4 T x 90 Degree swivel elbow	3
2	70214633	Relay, SS-120	2
3	70205326	Valve, VAC. Mead 4-way	1
4	708002	1/4 NPT x 2" nipple	1
5	70203980	Valve, 4-way	1
6	70207041	Cabinet, Wrap around, Offset	1
7	70203759	Main cylinder, 24 x 4	1
8	708004	1/4 NPT x 3/8 t x 90 degree swivel elbow	3
9	708005	1/8 NPT x 5/32 T x 90 Degree swivel elbow	2
10	991404	6-32 x 1 Button head screw	4
11	990038	Hex nut, 6-32	4
12	990145	Washer, 1/4 Lock	6
13	70207317	Block, Hopper mounting	1
14	990645	10-32 x 2 1/4 Cap screw	4
15	990728	Washer, #10 Lock	4
16	70201541	Bracket, Bushing block	1
17	70205896	Bracket, Guide pin safety	1
18	70205769	Switch, Safety guide pin	1

Item	Part #	Description	Qty
19	70200750	Terminal strip, 6 Position	1
20	990091	10-32 x 1/2 Button head screw	2
21	990103	Hex nut, 10-32	8
22	990090	10-32 x 3/8 Button head screw	4
23	990081	10-32 x 1/2 Cap screw	4
24	990180	Washer, 5/16 SAE	12
25	990171	5/16-18 x 1 Cap screw	4
26	70207355	Switch, Cover	1
27	70209539	Cylinder, H-block	1
28	70215038	H-block kit	1
29	706009	Locking nut, Hopper cylinder	1
30	990147	Hex nut, 1/4-28	1
31	70206850	1/8 NPT x 5/32T Flow control valve	2
32	360202	1/4 Hex nipple	1
33	708045	1/4NPT x 90 degree 44 union elbow	1
34	990169	1/4-20 x 3/8 Nylon tip set screw	1
35	991405	5/16 -24 x 1 1/4 Cap screw	4
36	990125	1/4-20 x 1 1/2 Cap screw	2

Main Cylinder / Platen Assembly Drawing

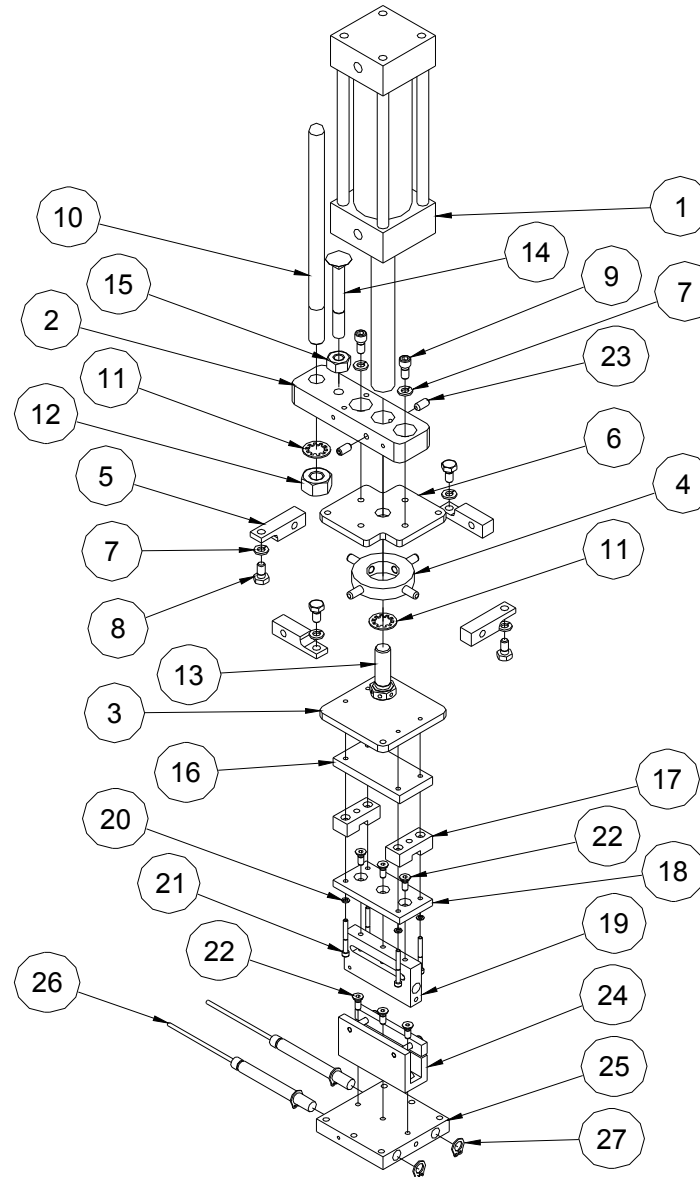

Main Cylinder / Platen Parts List

Item	Part #	Description	Qty
1	70203759	Main cylinder, 24 x 4	1
2	70200981	Bar guide pin	1
3	70202987	Small ring bottom plate	1
4	70203000	Ring, Small self level	1
5	70202968	Ring small pivot block	4
6	70202972	Small ring top plate	1
7	990145	Washer, 1/4 Lock	6
8	990141	1/4-20 x 1/2 Hex head bolt	4
9	990120	1/4-20 x 1/2 Cap screw	2
10	70202510	Pin, Guide, 8 1/2	1
11	991229	Washer, 1/2 Internal tooth	2
12	991230	Hex nut, 1/2-13	1
13	70209952	Bolt, Head ass'y	1
14	991232	3/8-16 x 3 Carriage bolt	1

Item	Part #	Description	Qty
15	990204	3/8-16 Hex nut	1
16	70202597	Plate, 4 Hole head, Glass	1
17	70202578	Plate, 3 Hole head, Glass	2
18	70202600	Plate, 7 Hole head, Steel	1
19	70201734	Bracket, Cartridge holder, 3 Inch	1
20	989965	Washer, #6 Lock	4
21	991086	6-32 x 1 1/4 Cap screw	4
22	990196	10-32 x 1/2 Flat head screw	6
23	991231	1/4-20 x 1/2 Knurled cup point	2
24	70211651	U-channel & Mtg bar, 3 Inch	1
25	70211666	Block, Electro heat, 3 Inch	1
26	70200178	Heater, 3 Inch	2
27	990264	Snap ring, 3/8	4

Swing Arm & Base Plate Assembly Drawing

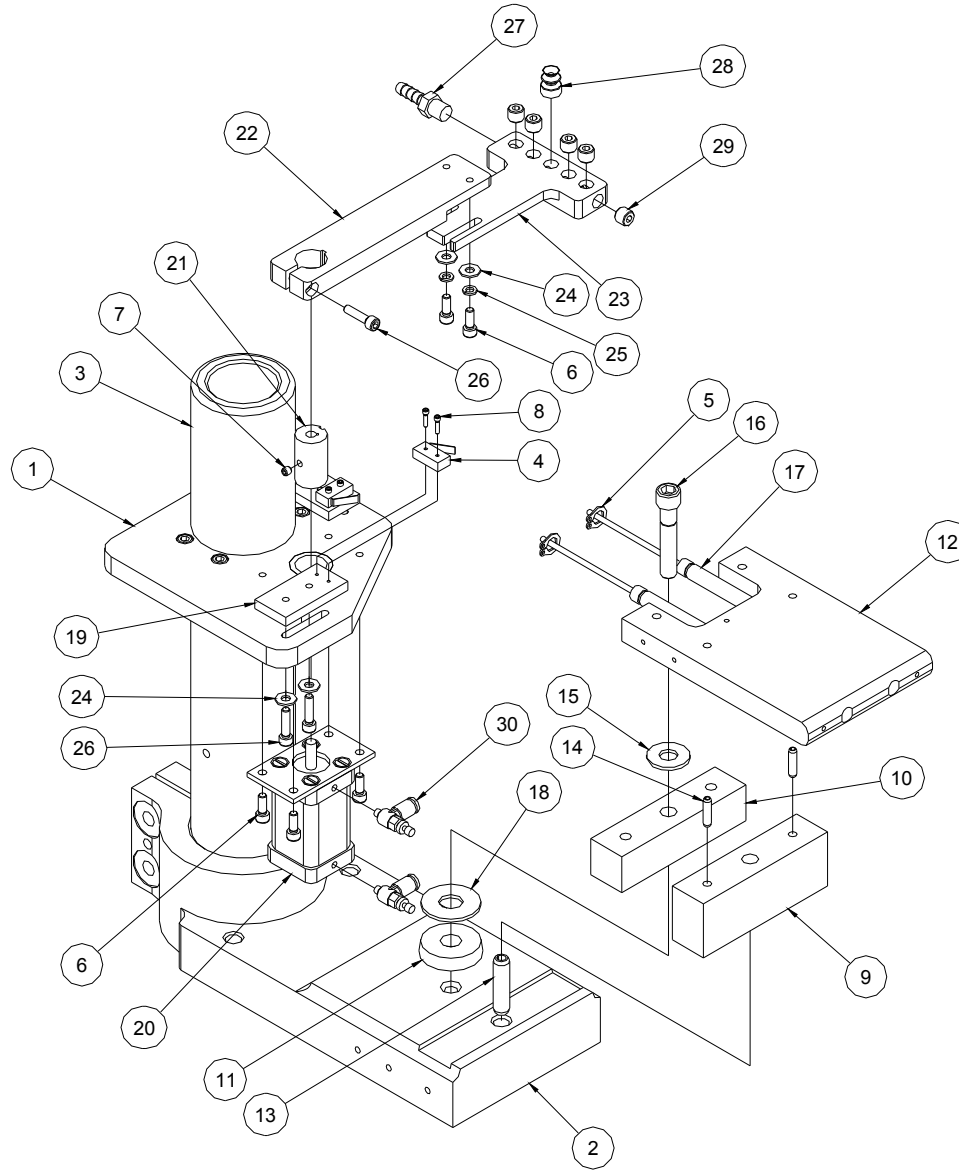

Swing Arm & Base Plate Parts List

Item	Part #	Description	Qty
1	70207567	Ass'y, Feed arm plate	1
2	70209100	Casting base, 12"	1
3	70201908	Column support, 15"	1
4	70215828	Switch, Micro	2
5	990264	Snap ring, 3/8	2
6	990081	10-32 x 1/2 Cap screw	6
7	990098	10-32 x 1/4 Knurled cup point	1
8	989997	2-56 x 3/8 Cap screw	4
9	70201109	Block, Insulating 1 1/2 inch	1
10	70201113	Block, Insulating 1 inch	1
11	70203655	Washer, Rubber silicone	1
12	70202690	Plate, Base, 4"	1
13	991234	Roll pin, 3/8 x 1 1/2	1
14	990244	Roll pin, 3/16 x 3/4	2
15	990207	Washer, 3/8 Flat	1

Item	Part #	Description	Qty
16	70211914	3/8-16 x 2 Nylok cap screw	1
17	70200182	Heater, 4 Inch	2
18	991288	Washer, 1/2" USS	1
19	70207588	Bracket, Limit SW mtg	2
20	70215011	Actuator, Rotary (1810-0700) SM	1
21	707041	Coupling, Actuator feed arm	1
22	708040	Bracket, Vacuum block mount	1
23	708041	Bracket, Vacuum cup holder	1
24	990102	Washer, #10 SAE	6
25	990728	Washer, #10 Lock	2
26	990083	10-32 x 3/4 Cap screw	5
27	708020	1/8 x 1/4 Brass hose barb	1
28	70214185	Vacuum cup VP10lbs	1
29	361129	1/8 NPT Hex SOC plug	5
30	70207707	Valve, Flow control, 10-32UNF x 1/8T	2

Manifold Assembly Drawing

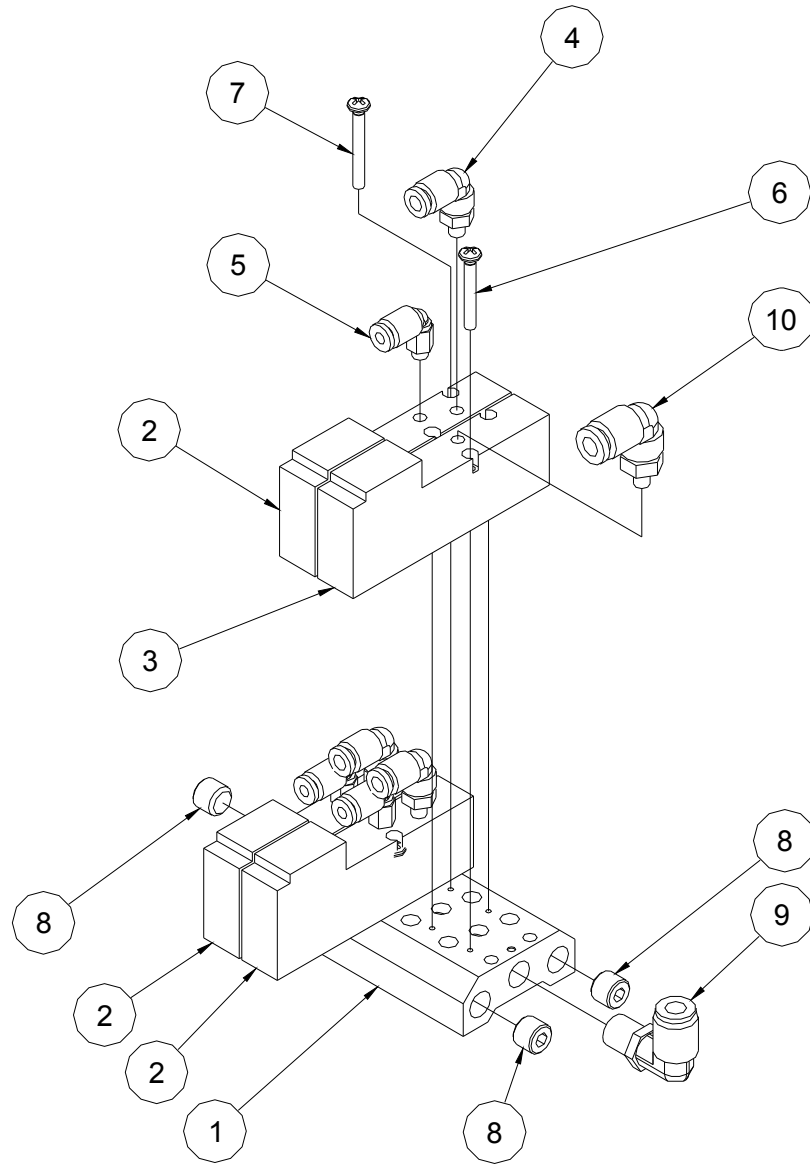

Manifold Parts List

Item	Part #	Description	Qty
1	70209440	Manifold (H110-M4F)	1
2	70209420	Valve 4 way (H110-4E1-PSL L1)	3
3	70209435	Valve 3 way (H110-E1-PSL-L1-120VAC)	1
4	708014	10-32 x 5/32 Swivel elbow, prl	3
5	708001	10-32 x 5/32 Swivel elbow	3
6		(Screws included with item 1, 2 & 3 above)	2
7		(Screws included with item 1, 2 & 3 above)	6
8	361129	1/8 NPT Hex soc plug	3
9	708039	1/8 x 1/4 x 90 degree swivel elbow	1
10	708015	10-32 x 1/4 swivel elbow, prl	1

Vacuum & Regulator Assembly Drawing

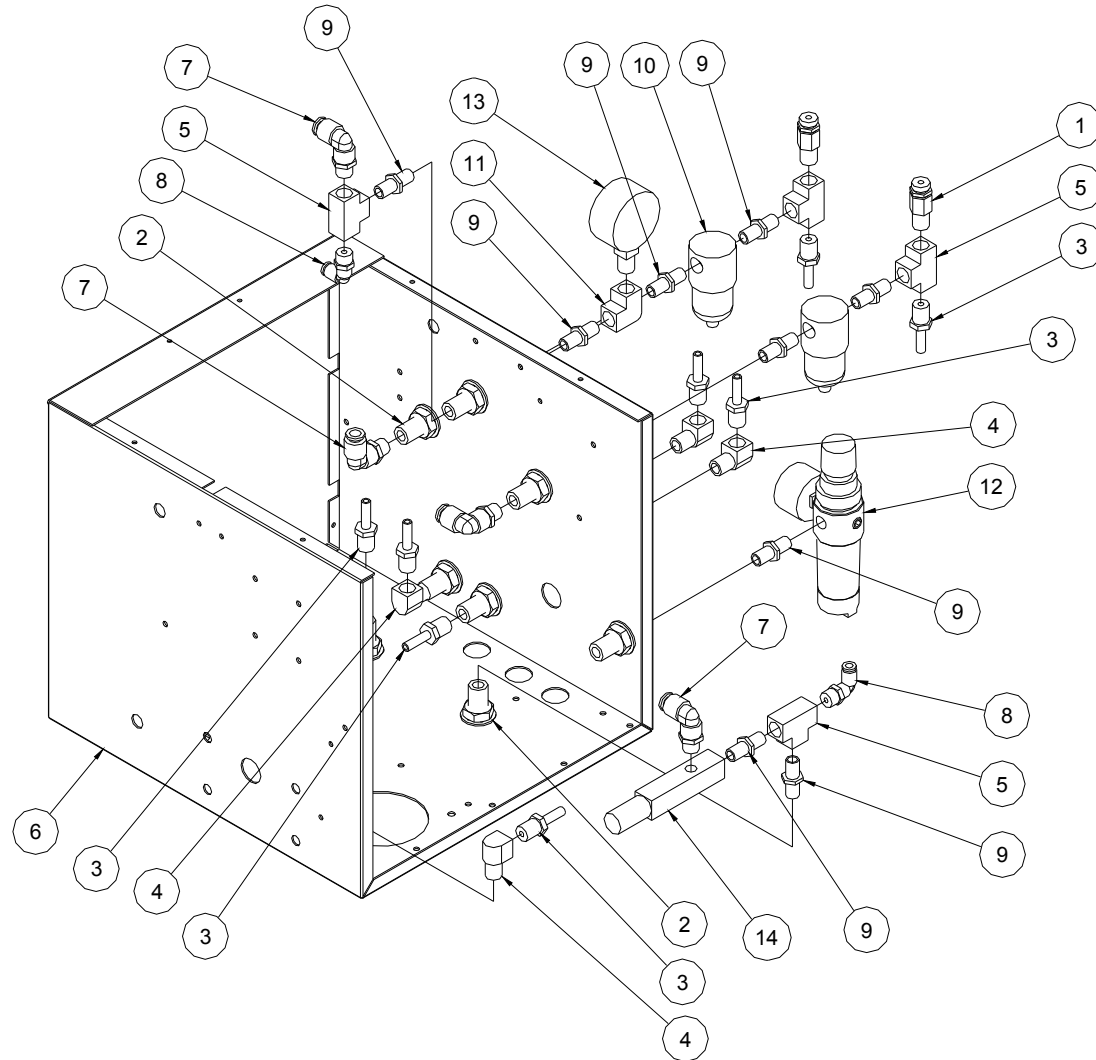

Vacuum & Regulator Parts List

Item	Part #	Description	Qty
1	70204041	Valve, Vacuum bleed	2
2	708008	1/4NPT Anchor coupling	9
3	708019	1/4 x 1/4 Brass hose barb	9
4	708011	1/4NPT x 90 deg street elbow	4
5	708010	1/4 Union tee	4
6	70207041	Cover, Cab wrap around, Offset	1
7	708004	1/4NPT x 3/8T x 90 Deg Swivel elbow	4
8	708003	1/4NPT x 1/4T x 90 deg Swivel elbow	2
9	708006	1/4 Hex nipple	9
10	70205294	Vacuum filter	2
11	708007	1/4NPT x 90 deg union elbow	1
12	70203848	Filter regulator, with Bowl guard	1
13	70206403	Gauge, Vacuum	1
14	70214987	Pump vacuum	1

2" Hopper Feed Assembly Drawing

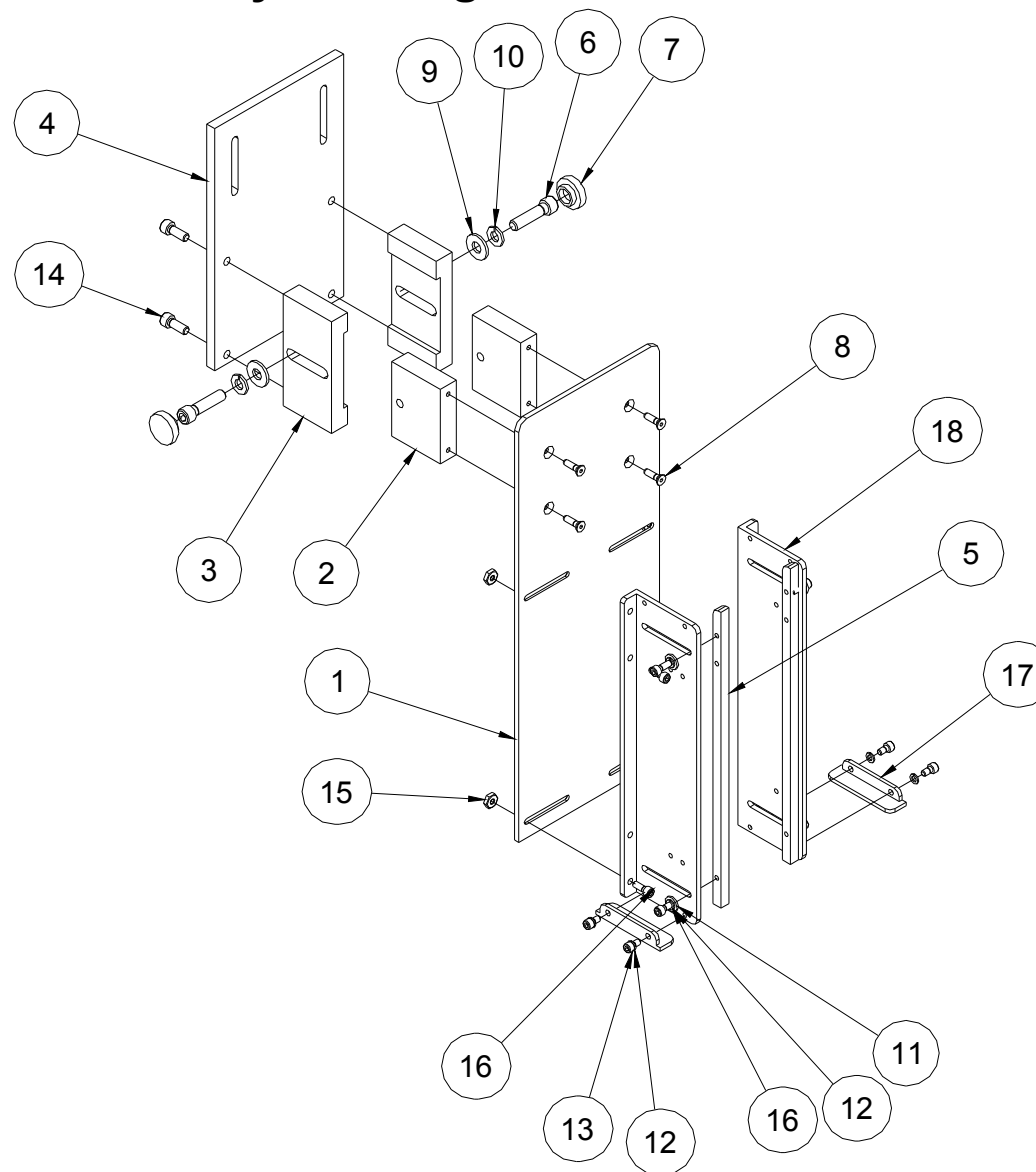

2" Hopper Feed Parts List

Item	Part #	Description	Qty
1	70209365	Hopper back	1
2	70205434	Block slider	2
3	70205449	Slider block, 1 1/2	2
4	70207321	Plate, Hopper mtg, 7112HF	1
5	70209740	Bar, Front rail	2
6	990123	1/4-20 x 1 Cap screw	2
7	990315	Thumb cap, 1/4-20	2
8	990023	6-32 x 1/2 Flat head screw	4
9	990167	Washer, 1/4 SAE	2

Item	Part #	Description	Qty
10	990145	Washer, 1/4 Lock	2
11	990037	Washer, #6 SAE	4
12	989965	Washer, #6 Lock	8
13	990015	6-32 x 1/4 Cap screw	4
14	990081	10-32 x 1/2 Cap screw	4
15	989987	Hex nut, 6-32 Nylok	4
16	990016	6-32 x 3/8 Cap screw	8
17	70210485	Bracket, Stripper bar, RH	2
18	70209295	Hopper side rail, 2" RH	2

3" Hopper Feed Assembly Drawing

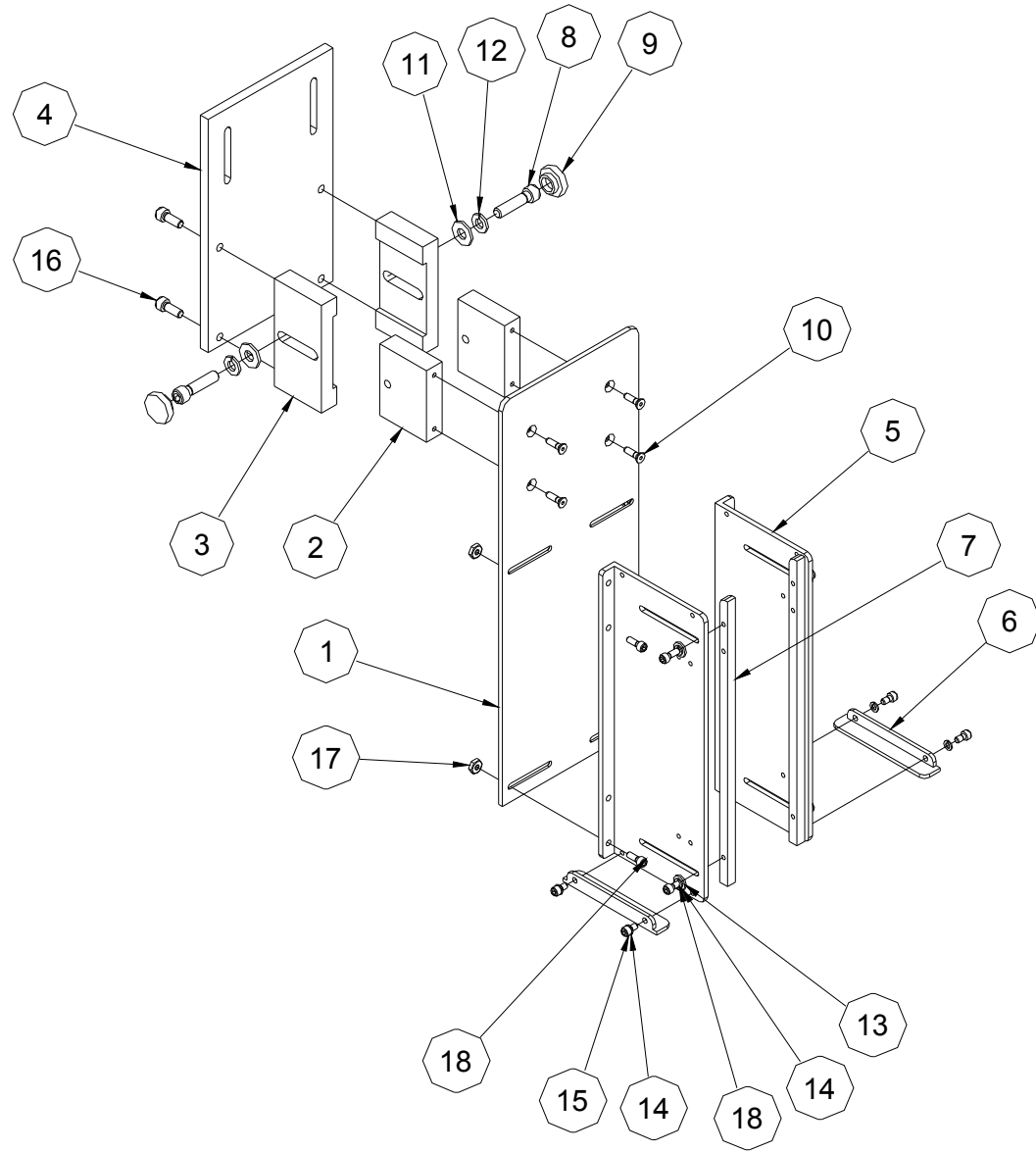

3" Hopper Feed Parts List

Item	Part #	Description	Qty
1	70209365	Hopper back	1
2	70205434	Block slider	2
3	70205449	Slider block, 1 1/2	2
4	70207321	Plate, Hopper mtg, 7112HF	1
5	70212320	Bracket, Hopper side rail, RH	2
6	70210502	Bracket, Stripper bar, RH	2
7	70209740	Bar, Front rail	2
8	990123	1/4-20 x 1 Cap screw	2
9	990315	Thumb cap, 1/4-20	2

Item	Part #	Description	Qty
10	990023	6-32 x 1/2 Flat head screw	4
11	990167	Washer, 1/4 SAE	2
12	990145	Washer, 1/4 Lock	2
13	990037	Washer, #6 SAE	4
14	989965	Washer, #6 Lock	8
15	990015	6-32 x 1/4 Cap screw	4
16	990081	10-32 x 1/2 Cap screw	4
17	989987	Hex nut, 6-32 Nylok	4
18	990016	6-32 x 3/8 Cap screw	8

Free Manuals Download Website

<http://myh66.com>

<http://usermanuals.us>

<http://www.somanuals.com>

<http://www.4manuals.cc>

<http://www.manual-lib.com>

<http://www.404manual.com>

<http://www.luxmanual.com>

<http://aubethermostatmanual.com>

Golf course search by state

<http://golfingnear.com>

Email search by domain

<http://emailbydomain.com>

Auto manuals search

<http://auto.somanuals.com>

TV manuals search

<http://tv.somanuals.com>