

EIR205 Series Quick Start Guide

Package Contents

- EIR205 Series Industrial, Unmanaged, Ethernet Switch
- Quick Start Guide (One per shipment)
- Power Terminal Block (installed)
- Fiber Optic Dust Covers (installed on fiber optic models)

If any item is missing or damaged, contact B&B Electronics for a replacement

Front Panel

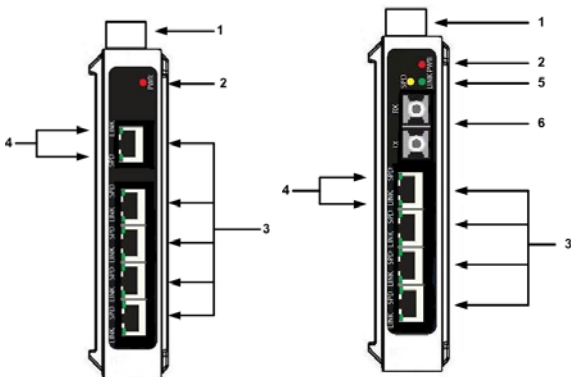

EIR205 (All RJ45)

EIR205 (1 Fiber, 4 RJ45)

| | | |
|---|----------------------|---|
| 1 | Power Terminal Block | 2 Position, Removable |
| 2 | PWR LED | ON When Power Applied |
| 3 | RJ45 Ports | Number Depends on Model |
| 4 | RJ45 SPD LED | ON if 100 mbps |
| 4 | RJ45 LINK LED | ON When RJ45 Port Linked Flashes When Data Transmitted |
| 5 | Fiber Optic SPD LED | Normally OFF (100BaseFx) |
| 5 | Fiber Optic LINK LED | On When Fiber Port Linked |
| 6 | Fiber Ports | Number and Type Depends on Model |

DIN Rail Mounting

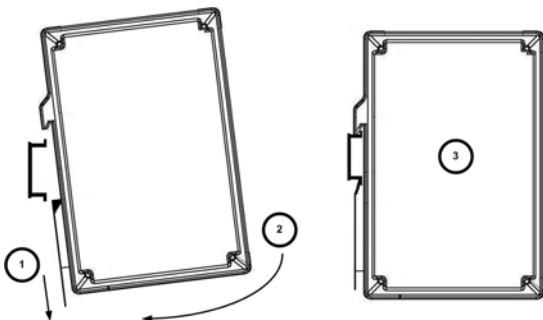

1. Slide and hold the DIN clip toward the bottom of the switch. Angle the top portion of the DIN mount over the top of DIN Rail.
2. Move the switch so that it is parallel with the DIN Rail.
3. Let go of the DIN Clip. The spring should return it to its original position.

Attach Power Leads External Supply Required



Warning: Work Safe – Equipment damage or electrical shock hazard exists. DO NOT ATTACH OR REMOVE LEADS WITH THE POWER SUPPLY ENERGIZED!

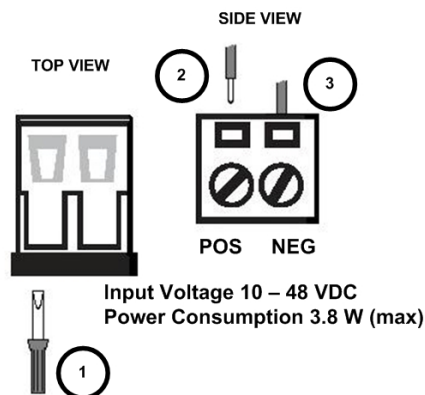

1. Loosen the screw to open the terminal block lead clamp.
2. Insert the power lead. TB will accept 12-28 AWG wire.
3. Tighten the screw to close the terminal block lead clamp. Ensure the clamp holds the lead securely. However, do not over tighten.

NOTE: For Replacement Terminal Block order Part # 7444.

Attach RJ45 Cable

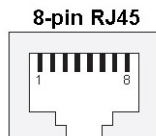

1. Auto MDI/MDI-x is supported. A straight through or cross-over cable may be used.
2. 10/100BaseT auto negotiation and full/half-duplex are supported.

| MDI Cable Pinout | |
|------------------|--------|
| Pin | Signal |
| 1 | Tx+ |
| 2 | Tx- |
| 3 | Rx+ |
| 6 | Rx- |

| MDI-X Cable Pinout | |
|--------------------|--------|
| Pin | Signal |
| 1 | Rx+ |
| 2 | Rx- |
| 3 | Tx+ |
| 6 | Tx- |

B&B electronics
MANUFACTURING COMPANY

International Headquarters: 707 Dayton Road PO Box 1040 Ottawa, IL 61350 USA
815-433-5100 Fax 433-5104 www.bb-elec.com orders@bb-elec.com support@bb-elec.com

European Headquarters: Westlink Commercial Park Oranmore Co. Galway Ireland
+353 91 792444 Fax +353 91 792445 www.bb-europe.com orders@bb-europe.com support@bb-europe.com
Download from www.Somanuals.com. All Manuals Search And Download.

Attach Fiber Optic Cable (if equipped)



Warning: Work Safe – Fiber Optic equipped models are Class I Laser/LED devices. To avoid causing serious damage to your eyes, DO NOT STARE DIRECTLY INTO THE LIGHT.

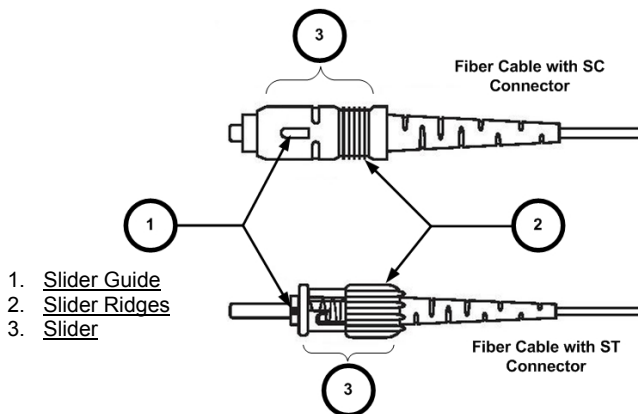

1. Slider Guide
2. Slider Ridges
3. Slider

1. Ensure your fiber optic cable is terminated with the correct connector type. EIR205 switches use SC or ST connectors.
2. Fiber optic type for each port is located on the product's side label. When connecting the cable to the switch, be sure to line up the slider guide on the cable and switch connectors.
3. Connect the fiber optic transmitter to the downstream device's receiver and vice-versa.

Fiber Optic Cable Information

| Mode and Distance | Type | Wavelength |
|---------------------|------------------|------------|
| Multi-mode (2 km) | 62.5/125 μ m | 1310 nm |
| Single-mode (15 km) | 9/125 μ m | 1310 nm |
| Single-mode (40 km) | 9/125 μ m | 1310 nm |
| Single-mode (80 km) | 9/125 μ m | 1550 nm |

| | Output Power | RCVR Sensitivity |
|---------------------|----------------|------------------|
| Multi-mode (2 km) | -19 to -14 dBm | \leq -32 dBm |
| Single-mode (15 km) | -15 to -8 dBm | \leq -32 dBm |
| Single-mode (40 km) | -5 to 0 dBm | \leq -34 dBm |
| Single-mode (80 km) | -5 to 0 dBm | \leq -34 dBm |

Installation Complete

1. When the network cables are attached and power is applied, installation is complete.
2. The switch will automatically discover network devices, populate its MAC address table, and pass traffic to the appropriate ports.

Mechanical Diagram

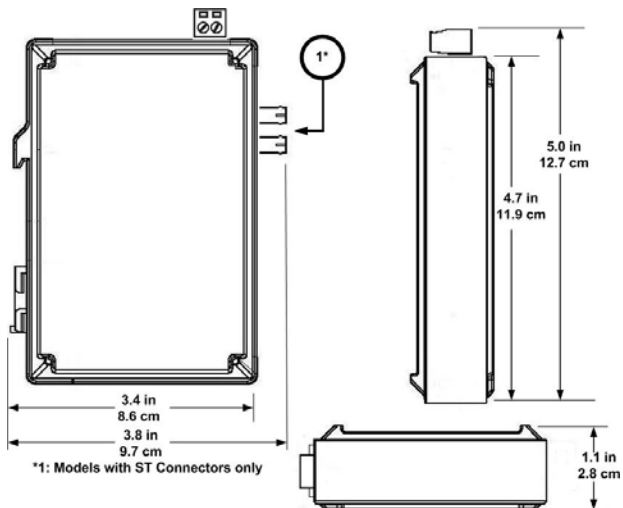

International Headquarters: 707 Dayton Road PO Box 1040 Ottawa, IL 61350 USA
 815-433-5100 Fax 433-5104 www.bb-elec.com orders@bb-elec.com support@bb-elec.com

European Headquarters: Westlink Commercial Park Oranmore Co. Galway Ireland
 +353 91 792444 Fax +353 91 792445 www.bb-europe.com orders@bb-europe.com support@bb-europe.com
 Download from www.Somaterials.com. All Manuals Search And Download.

Free Manuals Download Website

<http://myh66.com>

<http://usermanuals.us>

<http://www.somanuals.com>

<http://www.4manuals.cc>

<http://www.manual-lib.com>

<http://www.404manual.com>

<http://www.luxmanual.com>

<http://aubethermostatmanual.com>

Golf course search by state

<http://golfingnear.com>

Email search by domain

<http://emailbydomain.com>

Auto manuals search

<http://auto.somanuals.com>

TV manuals search

<http://tv.somanuals.com>