



# Encore VPx Installation Guide

---

## In This Guide

This guide provides installation instructions for the Encore VPx. The following topics are discussed in this guide:

- [Important Installation Notice](#)
- [Change History](#)
- [Copyrights and Notices](#)
- [Company Address](#)
- [Operators Safety Summary](#)
- [Terms and Equipment Marking](#)
- [VPx Overview](#)
- [VPx Hardware](#)
- [Installation](#)
- [Technical Specifications](#)

---

## Important Installation Notice

### Important

**Software version 1.22 (or higher) must be installed first in your Encore Controller, prior to connecting your VPx processor(s).** Refer to the [“Installing VPx”](#) section on page 16 for details.

---

## Change History

The table below lists the changes to this guide.

Table 1. Change History

Rev	Date	ECP #	Description	Approved By
00	4/2/08	556520	Encore VPx Installation Guide	K. Vogel

## Copyrights and Notices

### Copyright

© Barco, Inc. April 2, 2008

All rights reserved. No part of this document may be copied, reproduced or translated. It shall not otherwise be recorded, transmitted or stored in a retrieval system without the prior written consent of Barco.

### Notice

Barco provides this manual “as is” without warranty of any kind, either expressed or implied, including but not limited to the implied warranties or merchantability and fitness for a particular purpose. Barco may make improvements and/or changes to the product(s) and/or the program(s) described in this publication at any time without notice.

This publication could contain technical inaccuracies or typographical errors. Changes are periodically made to the information in this publication; these changes are incorporated in new editions of this publication.

### Federal Communications Commission (FCC) Statement

This equipment has been tested and found to comply with the limits for a class A digital device, pursuant to Part 15 of the FCC rules. These limits are designed to provide reasonable protection against harmful interference when the equipment is operated in a commercial environment. This equipment generates, uses, and can radiate radio frequency energy and, if not installed and used in accordance with the instruction manual, may cause harmful interference to radio communications. Operation of this equipment in a residential area may cause harmful interference, in which case the user will be responsible for correcting any interference.

### Guarantee and Compensation

Barco provides a guarantee relating to perfect manufacturing as part of the legally stipulated terms of guarantee. On receipt, the purchaser must immediately inspect all delivered goods for damage incurred during transport, as well as for material and manufacturing faults. Barco must be informed immediately in writing of any complaints.

The period of guarantee begins on the date of transfer of risks, in the case of special systems and software on the date of commissioning, at latest 30 days after the transfer of risks. In the event of justified notice of complaint, Barco can repair the fault or provide a replacement at its own discretion within an appropriate period. If this measure proves to be impossible or unsuccessful, the purchaser can demand a reduction in the purchase price or cancellation of the contract. All other claims, in particular those relating to compensation for direct or indirect damage, and also damage attributed to the operation of software as well as to other services provided by Barco, being a component of the system or independent service, will be deemed invalid provided the damage is not proven to be attributed to the absence of properties guaranteed in writing or due to the intent or gross negligence or part of Barco.

If the purchaser or a third party carries out modifications or repairs on goods delivered by Barco, or if the goods are handled incorrectly, in particular if the systems are commissioned

operated incorrectly or if, after the transfer of risks, the goods are subject to influences not agreed upon in the contract, all guarantee claims of the purchaser will be rendered invalid. Not included in the guarantee coverage are system failures which are attributed to programs or special electronic circuitry provided by the purchaser, e.g. interfaces. Normal wear as well as normal maintenance are not subject to the guarantee provided by Barco either.

The environmental conditions as well as the servicing and maintenance regulations specified in this manual must be complied with by the customer.

## Trademarks

Brand and product names mentioned in this manual may be trademarks, registered trademarks or copyrights of their respective holders. All brand and product names mentioned in this manual serve as comments or examples and are not to be understood as advertising for the products or their manufactures.

---

## Company Address



**Barco, Inc.**  
11101 Trade Center Drive  
Rancho Cordova, California 95670  
USA

- Phone: (916) 859-2500
- Fax: (916) 859-2515
- Website: [www.barco.com](http://www.barco.com)

**Barco N.V.**  
Noordlaan 5  
8520 Kurne  
BELGIUM

- Phone: +32 56.36.82.11
- Fax: +32 56.35.16.51

### Technical Support

- Tech Line: (866) 374-7878 — 24 hours per day, 7 days per week
- E-mail: [folsomsupport@barco.com](mailto:folsomsupport@barco.com)

## Operators Safety Summary

The general safety information in this summary is for operating personnel.

### Do Not Remove Covers or Panels

There are no user-serviceable parts within the unit. Removal of the top cover will expose dangerous voltages. To avoid personal injury, do not remove the top cover. Do not operate the unit without the cover installed.

### Power Source

This product is intended to operate from a power source that will not apply more than 230 volts rms between the supply conductors or between both supply conductor and ground. A protective ground connection by way of grounding conductor in the power cord is essential for safe operation.

### Grounding the Product

This product is grounded through the grounding conductor of the power cord. To avoid electrical shock, plug the power cord into a properly wired receptacle before connecting to the product input or output terminals. A protective-ground connection by way of the grounding conductor in the power cord is essential for safe operation.

### Use the Proper Power Cord

Use only the power cord and connector specified for your product. Use only a power cord that is in good condition. Refer cord and connector changes to qualified service personnel.

### Use the Proper Fuse

To avoid fire hazard, use only the fuse having identical type, voltage rating, and current rating characteristics. Refer fuse replacement to qualified service personnel.

### Do Not Operate in Explosive Atmospheres

To avoid explosion, do not operate this product in an explosive atmosphere.

---

## Terms and Equipment Marking



### WARNING

Highlights an operating procedure, practice, condition, statement, etc., which, if not strictly observed, could result in injury to or death of personnel.

#### Note

Highlights an essential operating procedure, condition or statement.



### CAUTION

The exclamation point within an equilateral triangle is intended to alert the user to the presence of important operating and maintenance (servicing) instructions in the literature accompanying the appliance.



### AVERTISSEMENT!

Le point d'exclamation dans un triangle équilatéral signale à alerter l'utilisateur qu'il y a des instructions d'opération et d'entretien très importantes dans la littérature qui accompagne l'appareil.



### VORSICHT

Ein Ausrufungszeichen innerhalb eines gleichwinkligen Dreiecks dient dazu, den Benutzer auf wichtige Bedienungs- und Wartungsanweisungen in der dem Great beiliegenden Literatur aufmerksam zu machen.

---

## VPx Overview

The following topics are discussed in this section:

- [Introduction to VPx](#)
- [Input Flexibility](#)
- [Scaling and Keying](#)
- [Output Flexibility](#)

### Introduction to VPx

The Encore Video Processor is a compact chassis that provides Encore's input and output circuitry. Two models are available:

- The "standard" Video Processor (**VP**) is a full-featured unit that includes all input, output, genlock and link circuitry.
- The **VPx** is an economical VP with a reduced set of inputs (DVI only). The VPx is ideal for widescreen configurations, and for special widescreen "preview" configurations. VPx includes all output and link circuitry, but no genlock circuitry, and only a small subset of the standard VP's input circuitry.
- In a widescreen configuration, a VPx cannot function in a standalone manner, but must always work *downstream* of a standard VP. Here, a VPx cannot be the first processor in an Encore configuration.
- In the special widescreen "preview" configuration, a VPx *can* be used as a standalone destination that accepts DVI input signals only — but no other input types are accepted, and no genlock circuitry is provided.

Both units provide a 3RU rack-mount chassis that can be configured with one, two or three M/E (mixer) boards. One or two M/E systems can be upgraded with additional M/E boards.

### Input Flexibility

The figure below illustrates a block diagram of the VPx's M/E.

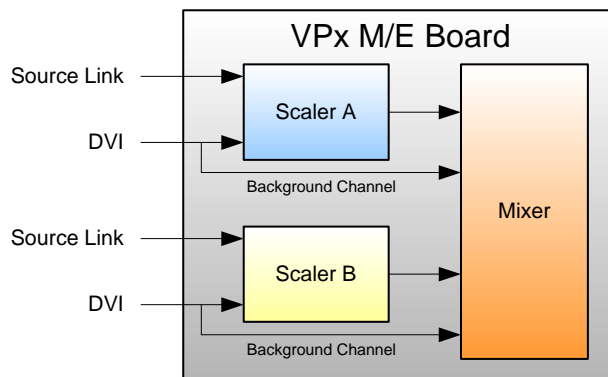

**Figure 1.** M/E Board Block Diagram, VPx

The VPx accepts computer input resolutions up to 1920 x 1200, via DVI.

## Scaling and Keying

For the VPx, the Athena scaler features the following:

- 1:1 pixel sampling
- 3:2 and 2:2 pull down detection
- Aspect ratio correction and image cropping
- Real-time window resizing and positioning
- Full support for seamless transitions, window borders, drop shadows and keying

## Output Flexibility

Each Encore VPx incorporates one output board, which provides all output interface functions as well as the blending and data-doubling functions required to support wide screen applications. Supported output resolutions include:

- Computer output resolutions up to 1600 x 1200
- Analog HDTV resolutions including 720p, 1080i, 1080p
- HD-SDI video
- 2048 x 1080p digital cinema video
- Plasma display resolutions.

## VPx Hardware

The following topics are discussed in this section:

- [VPx Front Panel](#)
- [VPx Rear Panel](#)
- [VPx M/E Connectors](#)
- [M/E Connector Priority](#)
- [M/E Input Notes](#)
- [Program Output Notes](#)

### VPx Front Panel

The figure below illustrates the VPx front panel:



Figure 2. VP Front Panel

1) <a href="#">Chassis Handles</a>	2) <a href="#">Air Intake Ports</a>	3) <a href="#">Status LED</a>
------------------------------------	-------------------------------------	-------------------------------

Following are descriptions of each front panel control feature:

#### 1) Chassis Handles

Two **Chassis Handles** are provided for ease of installation and transportation. When transporting the chassis by its handles, **do not** set it down with the rear connectors towards the ground. If you do, you may damage the rear connectors.

#### 2) Air Intake Ports

Two **Air Intake Ports** are provided for chassis cooling. The direction of airflow is from the front to the rear. To prevent overheating, do not block the air intake ports.

#### 3) Status LED

The **Status LED**, behind the right-hand **Air Intake Port**, indicates the following:

- ~ **Solid Red**: the unit is initializing
- ~ **Solid Green**: the unit is ready for use
- ~ **Blinking Red**: an error has occurred



## VPx Rear Panel

The figure below illustrates the VPx rear panel:

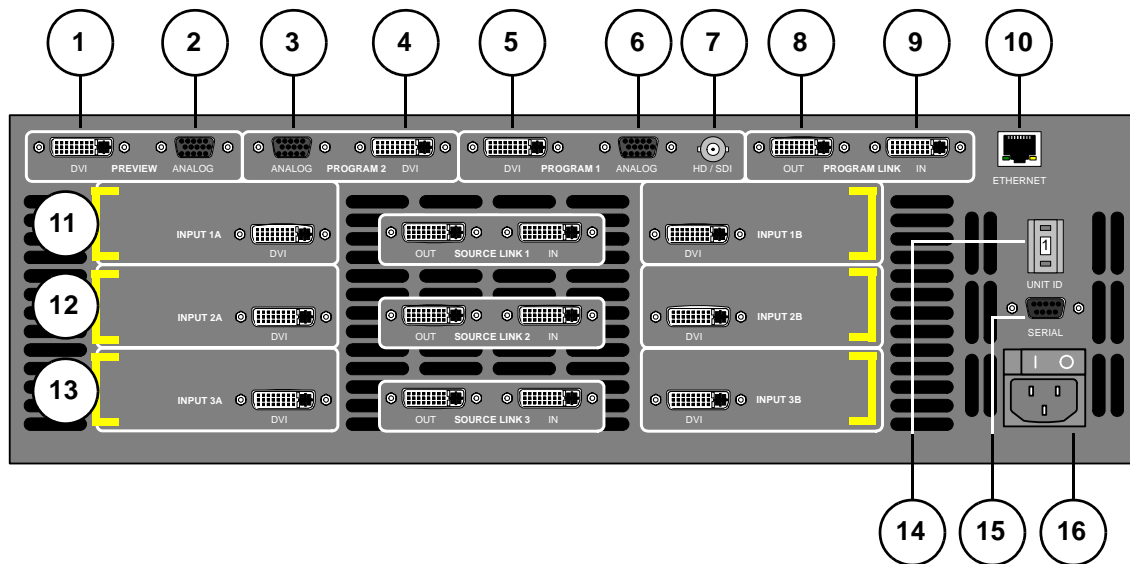

Figure 3. VPx Rear Panel

1) <a href="#">Preview Out DVI</a>	7) <a href="#">Program Out HD/SDI</a>	13) <a href="#">M/E 3 Connectors</a>
2) <a href="#">Preview Out Analog</a>	8) <a href="#">Program Link Out</a>	14) <a href="#">Unit ID Selector</a>
3) <a href="#">Program 2 Out Analog</a>	9) <a href="#">Program Link In</a>	15) <a href="#">Serial Port</a>
4) <a href="#">Program 2 Out DVI</a>	10) <a href="#">Ethernet Port</a>	16) <a href="#">AC Connector</a>
5) <a href="#">Program 1 Out DVI</a>	11) <a href="#">M/E 1 Connectors</a>	
6) <a href="#">Program 1 Out Analog</a>	12) <a href="#">M/E 2 Connectors</a>	

Please note:

- Connectors 1 through 10 are part of the VPx’s output board, and all output connections are standard. All program and preview DVI output connectors are digital only.
- In a widescreen configuration, a VPx cannot function in a standalone manner, but must always work *downstream* of a standard VP. Here, a VPx cannot be the first processor in an Encore configuration.
- In the special widescreen “preview” configuration, a VPx *can* be used as a standalone destination that accepts DVI input signals only — but no other input types are accepted, and no genlock circuitry is provided.
- This guide does not provide connector pinouts. Refer to **Appendix A** in the **Encore Presentation System User’s Guide** for details.

Following are descriptions of each rear panel connector and section on the VPx.

### 1) Preview Out DVI

One DVI connector is provided for **Digital Preview Output**.

### 2) Preview Out Analog

One 15-pin D connector is provided for **Analog Preview Output**.

### 3) Program 2 Out Analog

One 15-pin D connector is provided for the **Analog Program 2 Output**. This output is identical to the analog **Program 1 Output**, except that it does not include edge feathering and data doubling components.

### 4) Program 2 Out DVI

One DVI connector is provided for the **Digital Program 2 Output**. This output is identical to the digital **Program 1 Output**, except that it does not include edge feathering and data doubling components.

### 5) Program 1 Out DVI

One DVI connector is provided for the **Digital Program 1 Output**. This output includes all edge feathering and data doubling components, and is designed for a digital connection to your projector.

### 6) Program 1 Out Analog

One 15-pin D connector is provided for the **Analog Program 1 Output**. This output includes all edge feathering and data doubling components, and is designed for an analog connection to your projector.

### 7) Program Out HD/SDI

One BNC connector is provided for the **HD/SDI** (High Definition/Serial Digital Interface) output. Refer to the "[Program Output Notes](#)" section on page 14 for additional information on video outputs.

### 8) Program Link Out

One DVI connector is provided for the **Program Link Output**. To ensure proper data doubling in wide screen configurations, this output connects to the **Program Link Input** on another VPx.

### 9) Program Link In

One DVI connector is provided for the **Program Link Input**. To ensure proper data doubling in wide screen configurations, this input connects to the **Program Link Output** from another VP (or VPx).

#### Note

In Chapter 3 "Installation" of the **Encore Presentation System User's Guide**, refer to the "**Program and Source Link Connections**" section for details on the link connectors in wide screen configurations.

### 10) Ethernet Port

One RJ-45 connector is provided for 10/100BaseT **Ethernet** communications. For multiple connections, use an Ethernet switch on an isolated network.

### 11) M/E 1 Connectors

### 12) M/E 2 Connectors

### 13) M/E 3 Connectors

Six analog and digital connectors are provided for each M/E. Please note:

- ~ All M/E boards are identical on a VPx. See the "[VPx M/E Connectors](#)" section on page 12 for details.
- ~ Refer to the "[M/E Connector Priority](#)" section on page 13 for important information on connector priority.

## 14) Unit ID Selector

One 16-position selector (with physical digits **0 - 15**) is provided for setting an unique **ID** on a VPx. The selector enables you to assign logical IDs **1 to 16**.

**Note**

Physical digit **0** equates to logical ID **16**.

By default, a VPx is configured as an **DHCP Client**, and it automatically obtains an IP address when it sees a **DHCP Server**. Controller Models SC and LC are configured (by default) as DHCP Servers.

**Note**

Always ensure that each VPx has a unique **ID**. During setup, the **ID** is used during various configuration procedures.

**Note**

Using the **Miscellaneous Menu**, you can re-define IDs using numbers **17 - 32**. In Chapter 5 of the **Encore Presentation System User's Guide**, refer to the "**Miscellaneous Menu**" section for details.

## 15) Serial Port

One 9-pin D connector is provided for RS-232 serial communications with VPx.

## 16) AC Connector

One **AC Connector** is provided to connect the VPx to your AC source.

See the "[Program Output Notes](#)" section on page 14 for more information on VPx outputs.

## VPx M/E Connectors

The figure below illustrates a close-up of the M/E connectors on the VPx. Even though the figure uses M/E 1's board, all M/E connections are identical on the VPx.

**Note**

The M/E connectors on a VPx are identical to those on a VP, minus the analog and HD/SDI connectors.

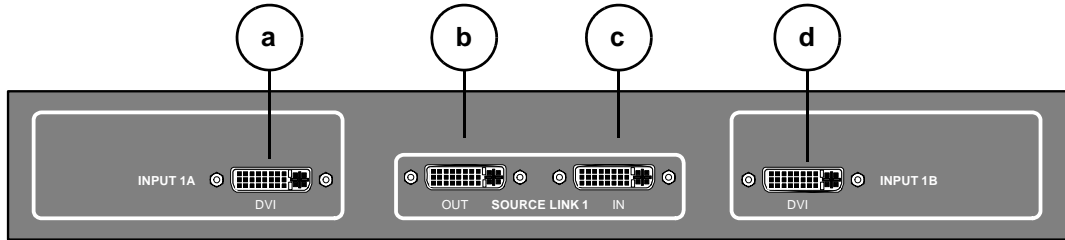

Figure 4. VPx M/E Connectors

a)	<a href="#">DVI Input A</a>	c)	<a href="#">Source Link In</a>	d)	<a href="#">DVI Input B</a>
b)	<a href="#">Source Link Out</a>				

On each M/E, one input connection is provided for layer **A**, one for layer **B**, and two “**Link**” connectors for inter-Processor communications. Following are descriptions of each M/E connector on a VPx.

**a) DVI Input A**

One DVI-I connector is provided for both digital and analog inputs to the M/E's **Layer A** and background channel.

- ~ **Digital** — connect a digital graphics source directly, or connect the output of a digital graphics router.
- ~ **Analog** — using the appropriate adapter cable, connect an analog source directly.

Refer to the “[M/E Input Notes](#)” section on page 14 for important details on the use of this connector's analog component.

**b) Source Link Out**

One DVI connector is provided for the M/E's **Source Link Output**. For wide screen and multi-screen applications, this connector loops your inputs to the *next* VP or VPx in the chain. Because all analog and digital inputs reside in the digital domain, each “link” output loops those inputs to the next Processor's scalers.

An M/E's **Source Link Output** must *always* be connected to its associated M/E **Source Link Input** on the next chassis, and never cross-routed.

Please note:

- ~ In a multi-chassis configuration, the link can extend to all chassis.
- ~ In all cases, the looped inputs are “pre-scaler.”

**c) Source Link In**

One DVI connector is provided for the M/E's **Source Link Input**. For wide screen and multi-screen applications, this connector accepts the looped outputs from the

previous VP or VPx in the chain. An M/E's **Source Link Input** must *always* be connected to its associated M/E **Source Link Output** on the previous chassis, and never cross-routed.

**Note**

In Chapter 3 "Installation" of the **Encore Presentation System User's Guide**, refer to the "Program and Source Link Connections" section for details on the link connectors in wide screen configurations.

**d) DVI Input B**

One DVI-I connector is provided for both digital and analog inputs to the M/E's **Layer B** and background channel.

- ~ **Digital** — connect a digital graphics source directly to this input, or connect the output of a digital graphics router.
- ~ **Analog** — using the appropriate adapter cable, connect an analog source directly to this input.

Refer to the "[M/E Input Notes](#)" section on page 14 for details on the use of this connector's analog component.

## M/E Connector Priority

Depending on your VP or VPx configuration, the M/E connectors on the rear of the chassis do not necessarily relate 1:1 to the layer buttons in the Controller's **Layer Control Section**. Please note:

- The Controller's layer buttons are arranged left-to-right in order of visual priority, from the lowest (**Mixer 1**) to the highest (**Mixer 3**).
- The M/E boards are arranged in order of *electronic* priority, from the lowest (M/E 3) to the highest (M/E 1).
- Electronic priority does not equate 1:1 to visual priority, with regard to the silk-screened labels on the Controller.

With this in mind, the information below lists how the physical connectors relate to the various mixers on different VP and VPx configurations. Keep this correlation in mind when you are making rear-panel connections.

- In a **3 M/E** system:
  - ~ **M/E 1** connectors are the highest priority. They appear as **Mixer 3** on the Controller. The DSK will be connected to the M/E 1 board.
  - ~ **M/E 2** connectors have middle priority. They appear as **Mixer 2**.
  - ~ **M/E 3** connectors are the lowest priority. They appear as **Mixer 1**. Background sources will be connected to the M/E 3 board.
- In a **2 M/E** system:
  - ~ **M/E 1** connectors are the highest priority, and appear as **Mixer 2**. The DSK will be connected to the M/E 1 board.
  - ~ **M/E 2** connectors are the lowest priority, and appear as **Mixer 1**. Background sources will be connected to the M/E 2 board.
  - ~ **M/E 3** connectors are *not installed*.

- In a **1 M/E** system:
  - ~ **M/E 1** connector priorities are relative to the connectors being used:
    - The **DVI Input A** or **Analog Input A** connector could be set up as a Background input (lowest priority).
    - The **DVI Input B** or **Analog Input B** connector could be setup as a DSK input (highest priority).
  - This leaves the other connectors to fall in between Background and DSK. The rule stating that “**A**” connectors are lower in priority than “**B**” connectors still holds.
  - ~ **M/E 2** and **3** connectors are *not installed*.

## M/E Input Notes

Please note the following important points regarding M/E inputs:

- **Single Processor Configurations** — In the special widescreen “preview” configuration, a VPx can be used as a standalone destination that accepts DVI input signals only.
- **Multiple Processor Configurations** — In these configurations, you only need to connect inputs to the first VP. Inputs are automatically looped to all other VP and VPx units via the **Source Link** connections.
- **DVI-I Connectors** — There are two DVI-I connectors for each M/E (**A** and **B**), and each contains a digital and an analog input. Depending upon your application, you can use the input for a scaled or an unscaled source:
  - ~ The “digital” side accepts connections from a standard DVI output or digital graphic router. This side can be used as both a scaled input source or as an unscaled **Background / DSK** source.
  - ~ Using a breakout cable, the “analog” side accepts analog connections. This side is designed for inputting the system’s unscaled sources — **Background** and **DSK**.
    - The lowest priority M/E in your system must be used for inputting the **Background** source.
    - The highest priority M/E in your system must be used for inputting the **DSK** source.

## Program Output Notes

Please note the following important points regarding the Processor’s program outputs:

- **HD/SDI Outputs** — For the HD/SDI output, you can set the output to be **SDI** (SMPTE 259M-C, NTSC or PAL) or **HD-SDI** (SMPTE 292M, HDTV). When you set this output resolutions, all output connectors will output that same resolution.
- **DVI Program Outputs** — DVI Program outputs are digital only. They do not have analog connections.
- **Program 1 Outputs** — Edge feathering and data doubling are present on all Program 1 Outputs, provided that those features are enabled in the system’s **Output Menu**.

## Installation

The following topics are discussed in this section:

- [Unpacking and Inspection](#)
- [Site Preparation](#)
- [Cable and Adapter Information](#)
- [Rack-Mount Installation](#)
- [Installing VPx](#)

### Unpacking and Inspection

Before opening the VPx box, inspect it for damage. If you find any damage, notify the shipping carrier immediately for all claims. As you open the box, compare its contents against the packing slip. If you find any shortages, contact your sales representative.

Once you have removed all the components from their packaging and checked that all the components are present, visually inspect each unit to ensure there was no damage during shipping. If there is damage, notify the shipping carrier immediately for all claims.

### Site Preparation

The environment in which you install your VPx units should be clean, properly lit, free from static, and have adequate power, ventilation, and space for all components.

### Cable and Adapter Information

The table below provides information regarding cables and adapters:

**Table 2.** VPx cables and adapters

Cable / Adapter	Description	Quantity		
		1 M/E	2 M/E	3 M/E
Power (US)	18GA, 10A, 7.5 meter length	1	1	1
DVI-I Male to DVI-I Male	1 meter length	2	3	4
DVI Plug to VGA	Cable Adapter	2	4	4

### Rack-Mount Installation

Encore VPx units are designed to be rack mounted, and are supplied with front rack-mount hardware. Rear rack-mount brackets are available as a kit, and are recommended when units are mounted in transit cases.

When rack mounting VPx units, remember the following important points:

- Maximum ambient operating temperature for the unit is 40 degrees C.
- Leave at least one inch of space (front and rear) to ensure that the airflow through the fan and vent holes is not restricted.

# Encore VPx Installation Guide

## Installation

- Distribute the units evenly to prevent hazardous conditions that may be created by uneven weight distribution.
- Rack mount the units from the front rack ears using four rack screws (not supplied). Threads may be metric or otherwise — depending upon the rack type.
- Install the *lower* of the two mounting holes first.

## Installing VPx

This section provides detailed VPx installation procedures for the Encore configurations listed below. Select the desired configuration, and follow all steps.

### Important

Only valid VPx configuration procedures are included below. Note that steps for connecting peripherals (e.g., ScreenPRO-II, Aux destinations, routers, tally, D/As, etc.) in a system are *not* covered below, but are fully covered in Chapter 3 of the **Encore Presentation System User's Guide**.

### Important

**Software version 1.22 (or higher) must be installed first in your Encore Controller, prior to connecting your VPx processor(s).** Refer to Appendix C, "Upgrading Software" in the **Encore Presentation System User's Guide** for complete upgrade instructions.

The following installation procedures are provided:

- [Installing VPX in a Wide Screen Configuration](#)
- [Installing VPx in a Wide Screen Preview Configuration](#)
- [Installing VPx in a Wide Screen Stack Configuration](#)



## Installing VPX in a Wide Screen Configuration

The figure below illustrates a block diagram of a “triple” wide screen configuration that includes VPx. Use this diagram for reference in the following procedure. Please note:

- Aux destinations are not shown in the diagram.
- This procedure can be used for wide screen configurations consisting of from 2 to 32 screens. Horizontal, vertical, and “array” blending is set using the **Destination Setup Menu**.
- A VP must be used as the “master” processor. Thereafter, either a VP or a VPx can be used.
- Software version 1.22 (or higher) must be installed first in your Encore Controller, prior to connecting your VPx processor(s).

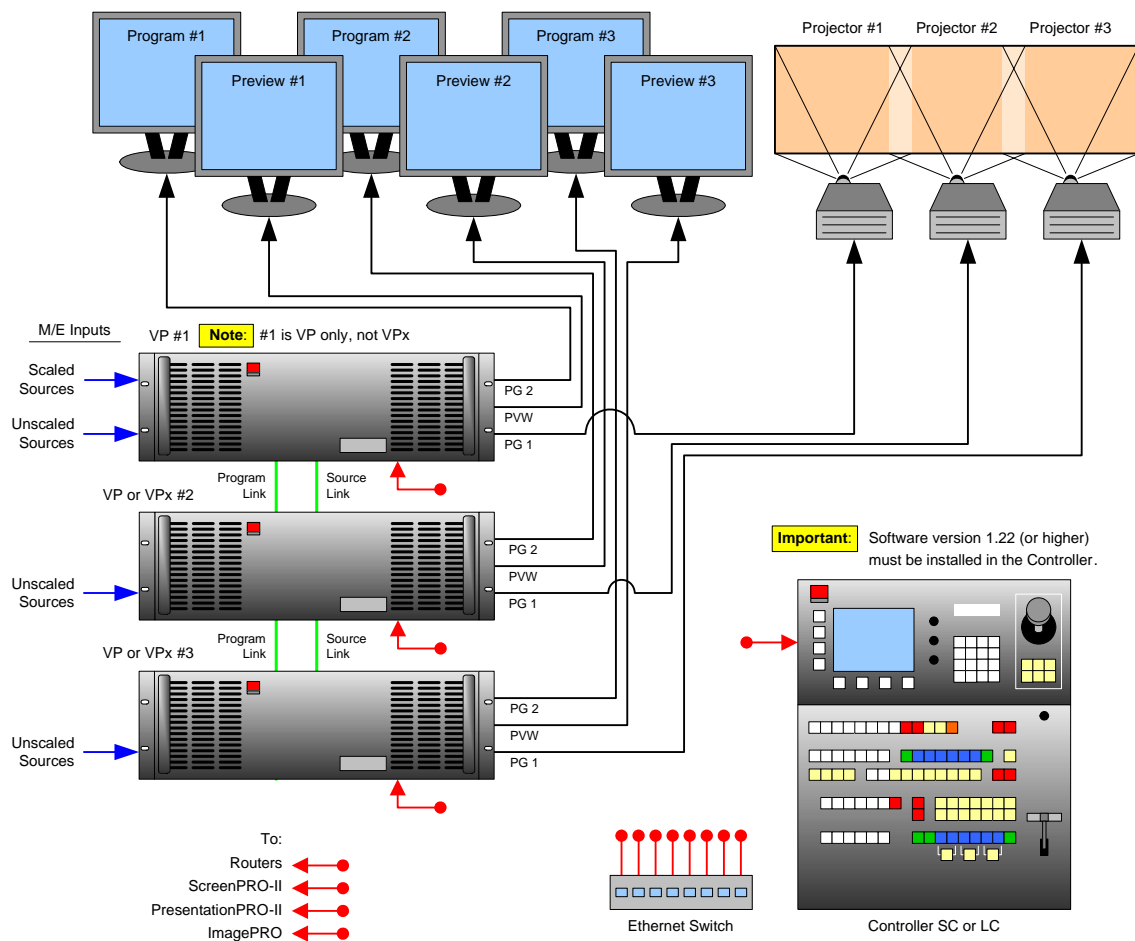

Figure 5. Block Diagram, Wide Screen Encore Configuration

# Encore VPx Installation Guide

## Installation

For this procedure, you will need:

**Table 3.** Equipment List, Wide Screen Encore Configuration

Qty.	Item	Note
1	VP	VPx cannot be used as the “master” processor
2	VP or VPx	Use either processor as a “slave” unit in a widescreen configuration
1	Controller	Model LC or SC
3	Video Projectors	Customer supplied.
6	DVI or Analog Monitors	Program and Preview (customer supplied).
1	Ethernet Switch	Customer supplied
4	Ethernet cables	Customer supplied. Additional cables required for routers.
TBD	Program Link Cables	Use 1 for double wide screen application, <b>left justification</b>
		Use 2 for triple wide screen application, <b>left justification</b>
		Use 2 for double wide screen application, <b>center justification</b>
		Use 3 for triple wide screen application, <b>center justification</b>
TDB	Source Link Cables	Dependent on the number of M/Es installed in the Processors
TBD	Sources, routers and cables	Analog, Video and/or DVI as required (customer supplied)

■ Use the following steps to install a wide screen Encore configuration that includes VPx:

- 1. Software Version** — Prior to connecting your VPx processor(s), ensure that software version 1.22 (or higher) is installed in your Encore Controller. Refer to Appendix C, “**Upgrading Software**” in the **Encore Presentation System User’s Guide** for complete upgrade instructions.
- 2.** Follow the unpacking procedures as listed in the “[Unpacking and Inspection](#)” section on page 15.
- 3.** Refer to the “[Technical Specifications](#)” section on page 28 for electrical and mechanical details.
- 4.** Refer to the “[VPx Hardware](#)” section on page 8 for all connector locations.
- 5.** For each VPx, follow the rack mount procedures as outlined in the “[Rack-Mount Installation](#)” section on page 15.
- 6. Ethernet Connections** — a totally “local” network connection is recommended. Connect the VP(s), VPx(s) and Controller to the Switch.
- 7. Direct Source Connections** — if you elect to use direct connections, in place of (or in addition to) router connections:
  - a.** Connect the desired “direct” sources to each M/E’s input connectors on each VPx. In a wide screen system, scaled sources only connect to Processor 1. “Links” carry the signals to the other VPx units.
  - b.** Unscaled **Backgrounds** must originate from computers with multi-head graphics cards, and connect to the same input on each VPx.
    - ▲ To connect an unscaled background source in a triple processor system (each VPx with three M/Es):
      - Connect the computer’s “head 1” to processor 1, input 3A

- Connect the computer's "head 2" to processor 2, input 3A
- Connect the computer's "head 3" to processor 3, input 3A

**Note**

Input 3A resides on the lowest priority M/E in a 3 M/E system. To connect a *second* background, use input 3B.

- c. The **DSK** source *may* originate from a computer with a multi-head graphics card, but it is not a requirement.

To use a multi-head graphics card for the DSK, connect it to the same input on each VPx — to the highest priority M/E (M/E 1).

- ▲ To connect an unscaled DSK source in a triple processor system (each processor with three M/Es):

- Connect the computer's "head 1" to processor 1, input 1A
- Connect the computer's "head 2" to processor 2, input 1A
- Connect the computer's "head 3" to processor 3, input 1A

**Note**

Input 1A resides on the highest priority M/E in a 3 M/E Encore system. If you wish to connect a *backup* DSK, use input 1B.

**8. Output Connections —**

- For each VPx, connect the analog or digital **Preview Output** to the input of the associated Preview Monitor.
- For each VPx, connect the analog or digital **Program 2 Output** to the input of the associated Program Monitor.
- For each VPx, connect the analog or digital **Program 1 Output** to the input of the associated projector.
- Connect the **Program Out HD/SDI** connector to an SDI or HDTV monitor as required, or to the proper video distribution equipment.

**Note**

This output only works if the selected output resolution is a valid SDI or HD/SDI format.

9. **Link Connections** — in a widescreen application, the **Program Link** and **Source Link** connections are used to connect processors together, and bridge inputs and outputs for the proper "overlap" between projectors. In Chapter 3 of the **Encore Presentation System User's Guide**, refer to the "**Program and Source Link Connections**" section for details.

10. **Power Connection** — connect AC power cords to all Encore and peripheral equipment, and then to AC outlets.

11. **System ID** — Using the **Unit ID Selector**, set the ID of Processor #1 to **1**, Processor #2 to **2**, and Processor #3 to **3**. Each unit must have a unique ID. Remember that you can redefine IDs using numbers **17 - 32** from the **Miscellaneous Menu**.

12. **Power On** — Refer to Chapter 6 of the **Encore Presentation System User's Guide** for all power on instructions.

### Installing VPx in a Wide Screen Preview Configuration

The figure below illustrates a “triple” wide screen configuration that includes a VPx, which is used to create a combined wide screen program/preview display.

Please note:

- Because a three M/E VPx provides up to 6 PIPs, this configuration is ideal for displaying a double or triple wide screen setup on a single monitor.

#### Note

This is the only configuration in which a VPx can be used in a single processor, standalone mode.

- For configurations using more than three processors, additional dedicated “preview” processors may be required, along with additional monitors.
- Software version 1.22 (or higher) must be installed first in your Encore Controller, prior to connecting your VPx processor(s).

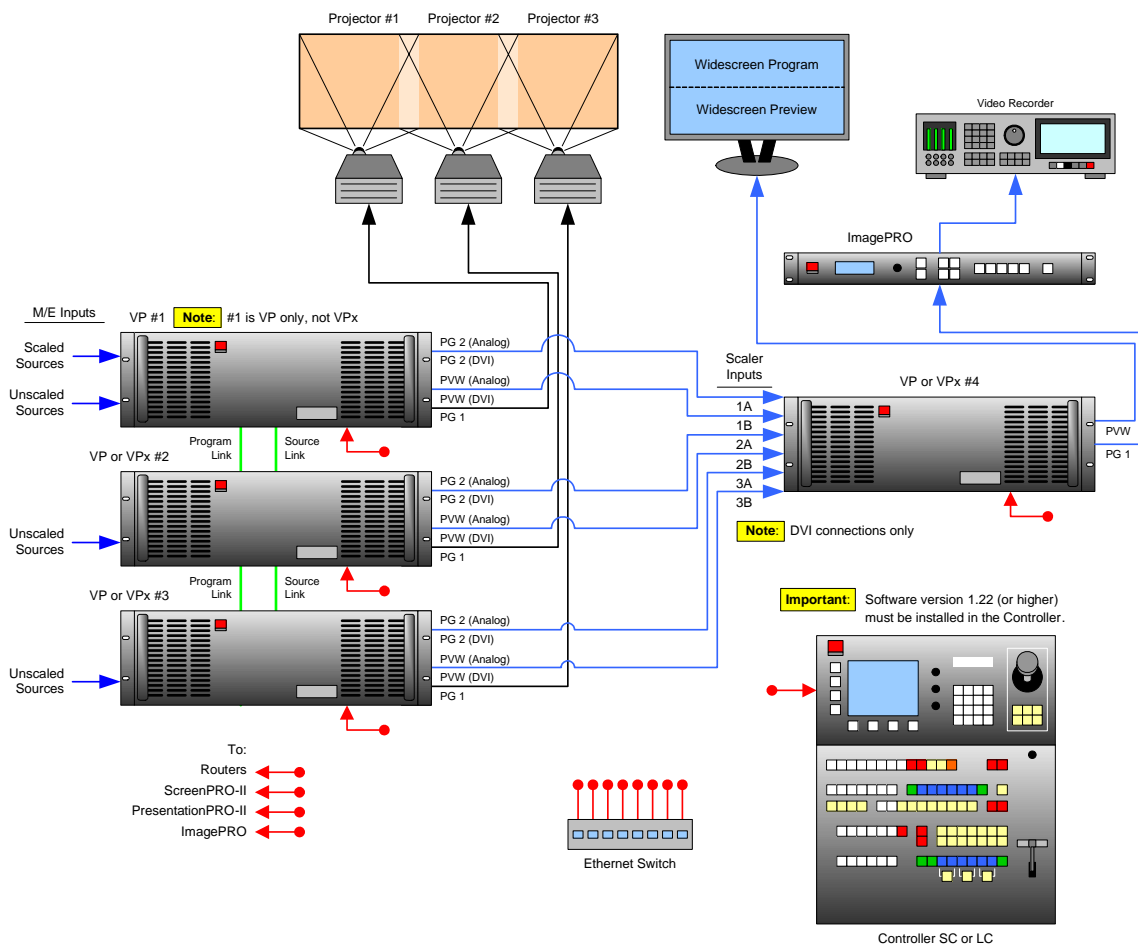
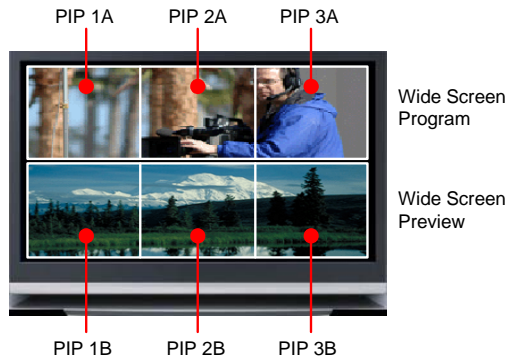

Figure 6. Block Diagram, Wide Screen Encore Configuration with Wide Screen Preview

Please note the following points regarding this configuration:

- Processor #4 (VPx) receives DVI Program and Preview feeds from processors #1, #2 and #3.
- Using Processor #4, three PIPs are scaled and positioned to create the wide screen Program display, and three more are scaled to create the Preview display.



**Figure 7.** Wide Screen Program/Preview Monitor PIPs

- Processor #4's **Preview** output is routed to the display for viewing the combined wide screen program/preview output.
- Processor #4's **Program** output is routed to an ImagePRO for scaling, and then to an SDI or HD-SDI recorder.

In addition to the equipment listed in [Table 3](#) on page 18, you will also need the following equipment for this setup:

**Table 4.** Equipment List, Additional Wide Screen Program/Preview Requirements

Qty.	Item	Note
1	VPx	Assigned as Video Processor #4
1	DVI or Analog Monitor	For wide screen program/preview display
1	Ethernet cable	Customer supplied
6	DVI interconnect cables	Inputs to video processor #4 (customer supplied)
2	Interconnect cables	Video processor #4 outputs (Analog, Video and/or DVI as required)
1	ImagePRO	Optional, for use as output scaler (customer supplied)
1	SDI or HD-SDI Video Recorder	Optional, to record combined wide screen output (customer supplied)

- Use the following steps to install an Encore system that includes a VPx, for a combined wide screen program/preview display:
  1. **Software Version** — Prior to connecting your VPx processor(s), ensure that software version 1.22 (or higher) is installed in your Encore Controller. Refer to Appendix C, “**Upgrading Software**” in the **Encore Presentation System User’s Guide** for complete upgrade instructions.
  2. Follow all steps to install a **Wide Screen Application**, as outlined in the “[Installing VPX in a Wide Screen Configuration](#)” section on page 17. You do not need to install the six individual monitors for program and preview displays, because you will be using *one* monitor instead.

# Encore VPx Installation Guide

## Installation

3. Rack mount processor #4.
4. Connect **Ethernet** from processor #4 to the Ethernet Switch.
5. **Source Connections** — connect DVI outputs from processors one, two and three to processor #4's scaler inputs:
  - ~ Connect processor #1 DVI Program 2 output to processor #4 input **1A**.
  - ~ Connect processor #1 DVI Preview 2 output to processor #4 input **1B**.
  - ~ Connect processor #2 DVI Program 2 output to processor #4 input **2A**.
  - ~ Connect processor #2 DVI Preview 2 output to processor #4 input **2B**.
  - ~ Connect processor #3 DVI Program 2 output to processor #4 input **3A**.
  - ~ Connect processor #3 DVI Preview 2 output to processor #4 input **3B**.

### Note

Program 2 output is used because it is a clean feed, without any edge feathering or data doubling in the signal.

6. **Output Connections** —
  - ~ Connect processor #4's analog or digital **Preview Output** to the input of your widescreen preview monitor.
  - ~ (Optional, for video recording) Connect processor #4's analog or digital **Program Output 1** or **2** to the input of the ImagePRO. Connect the ImagePRO's output to the input of your recorder. Refer to the "**ImagePRO User's Guide**" for connection and setup details.
7. **Power Connection** — connect AC power cords to the AC Power connectors on the rear of processor #4, the monitor and the ImagePRO.
8. **System ID** — Using the **Unit ID Selector**, set the ID of processor #4 to **4**.

### Note

Each processor must have a unique ID.

9. **Power On** — Refer to Chapter 6 of the **Encore Presentation System User's Guide** for all power on instructions.

### Important

In order to properly configure processor #4 and its Preview output, several important setup steps must be taken at the Controller. For full instructions, in Chapter 3 of the **Encore Presentation System User's Guide**, refer to the "**Completing Wide Screen Preview Setup**" section.

## Installing VPx in a Wide Screen Stack Configuration

The figure below illustrates a block diagram of a wide screen “stack” configuration that includes VPx. Aux destinations are not shown. Use this diagram for reference in the following procedure. Please note:

- Software version 1.22 (or higher) must be installed first in your Encore Controller, prior to connecting your VPx processor(s).

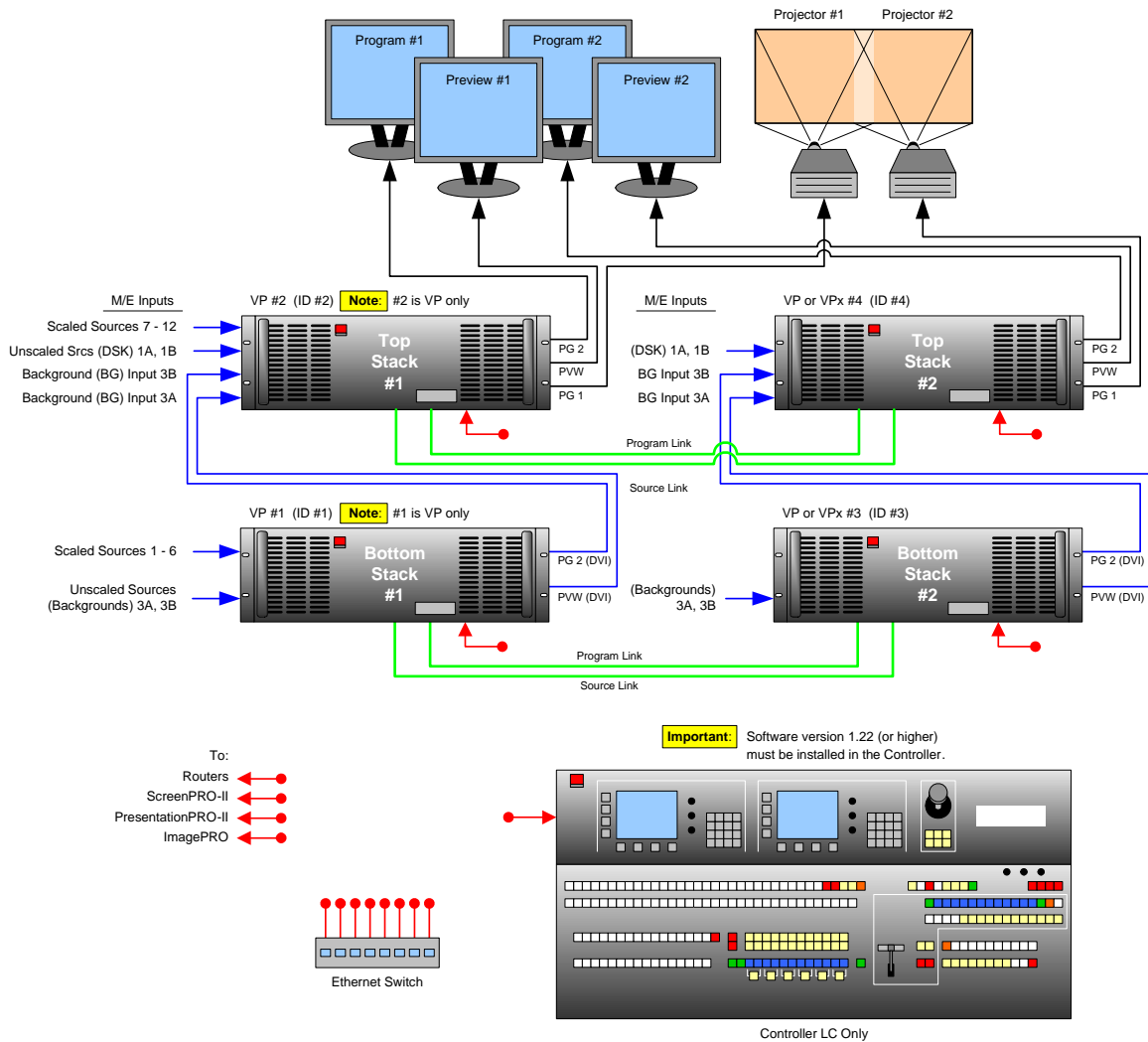

Figure 8. Block Diagram, Wide Screen Stack Configuration

# Encore VPx Installation Guide

## Installation

For this procedure, you will need:

**Table 5.** Equipment List, Wide Screen Stack Configuration

Qty.	Item	Note
2	VP	Master units (ID#1 and ID#2) must be VP, not VPx.
2	VP or VPx	The ID of the bottom stack processor must always be lower than the ID of the top stack processor. Use 6 total processors for triple wide screen, use 8 for quadruple wide, etc.
1	Controller	Model LC only
2	Video Projectors	Customer supplied
4	DVI or Analog Monitors	Program and Preview (customer supplied)
1	Ethernet Switch	Customer supplied
5	Ethernet cables	Customer supplied. Additional cables required for routers.
TBD	Program Link Cables	Use 2 for double wide screen application, <b>left justification</b>
		Use 4 for triple wide screen application, <b>left justification</b>
		Use 4 for double wide screen application, <b>center justification</b>
		Use 6 for triple wide screen application, <b>center justification</b>
TDB	Source Link Cables	Minimum 4 for double wide screen application.
TBD	Sources, routers, cables	Analog, Video and/or DVI as required (customer supplied)

- Use the following steps to install a wide screen “stack” configuration:

### Important

It is recommended that each stack consists of two “fully loaded” processors, each with three M/Es. If necessary, you *can* use a mis-matched configuration (e.g., two M/Es in the bottom stack, three in the top), but the top stack *must always* have three M/Es installed. In this way, your stacked set will never have anything less than four M/Es available.

1. **Software Version** — Prior to connecting your VPx processor(s), ensure that software version 1.22 (or higher) is installed in your Encore Controller. Refer to Appendix C, “**Upgrading Software**” in the **Encore Presentation System User’s Guide** for complete upgrade instructions.
2. Follow the unpacking procedures as listed in the “[Unpacking and Inspection](#)” section on page 15.
3. Refer to the “[Technical Specifications](#)” section on page 28 for electrical and mechanical details.
4. Refer to the “[VPx Hardware](#)” section on page 8 for all connector locations.
5. For each VPx, follow the rack mount procedures as outlined in the “[Rack-Mount Installation](#)” section on page 15.

### Important

Remember that master units (ID#1 and ID#2) must be VP, not VPx. “Slave” units can be VP or VPx.



6. **Ethernet Connections** — a totally “local” network connection is recommended. Connect the VP(s), VPx(s) and Controller to the Switch.
7. **Direct Source Connections** — if you elect to use direct connections, in place of (or in addition to) router connections:
- a. Connect “direct” sources to each M/E’s input connectors on each stack. Note that in a wide screen stack system, scaled sources only connect to stack #1. The “link” connections carry the signals to the other stacks:
    - On stack #1 only, connect “direct” sources 1 - 6 to each M/E’s input connectors on the “**bottom stack**” processor.
    - On stack #1 only, connect “direct” sources 7 - 12 to each M/E’s input connectors on the “**top stack**” processor.
  - b. Unscaled **Backgrounds** must originate from computers with multi-head graphics cards, and connect to the same input on each “bottom stack” processor.
    - ▲ To connect an unscaled background source in a double widescreen stack system (each processor with three M/Es):
      - On the first stack, connect the computer’s “head 1” to the bottom stack processor, input 3A
      - On the second stack, connect the computer’s “head 2” to the bottom stack processor, input 3A

**Note**

Input 3A resides on the lowest priority M/E in a 3 M/E system. To connect a *second* background source, use input 3B on both stacks.

- c. The **DSK** source *may* originate from a computer with a multi-head graphics card, but it is not a requirement.
  - ▲ Connecting a single-head graphics card to processor 4 only would enable a bug to be placed *only* in that screen space.

**Note**

The **DSK Setup Menu** allows you to pick an individual ID within a widescreen on which to perform DSK setup.

If you elect to use a multi-head graphics card for the DSK, ensure that you connect to the same input on each processor — to the highest priority M/E.

- ▲ To connect an unscaled DSK source in a double widescreen stack system (each processor with three M/Es):
  - On the first stack, connect the computer’s “head 1” to the top stack processor, input 1A
  - On the second stack, connect the computer’s “head 2” to the top stack processor, input 1A

**Note**

Input 1A resides on the highest priority M/E in a 3 M/E Encore system. If you wish to connect a backup (or alternate) DSK, use input 1B on both stacks.

### 8. Stack Interconnections —

- a. On the first stack:
  - Connect the bottom stack's **DVI Preview Output** to the top stack's Background 1 input (**3A**).
  - Connect the bottom stack's **DVI Program Output** to the top stack's Background 2 input (**3B**).
- b. On the second stack:
  - Connect the bottom stack's **DVI Preview Output** to the top stack's Background 1 input (**3A**).
  - Connect the bottom stack's **DVI Program Output** to the top stack's Background 2 input (**3B**).

### 9. Output Connections — all output monitor and projector connections originate from the “top stack” processors:

- a. On each “top stack” processor, connect the analog or digital **Preview Output** to the input of the associated Preview Monitor.
- b. On each “top stack” processor, connect the analog or digital **Program 2 Output** to the input of the associated Program Monitor.
- c. On each “top stack” processor, connect the analog or digital **Program 1 Output** to the input of the associated projector.
- d. Connect the “top stack” **Program Out HD/SDI** connector to an SDI or HDTV monitor, or to the proper video distribution equipment.

#### Note

This output only works if the selected output resolution is a valid SDI or HD/SDI format.

- e. If you elect to output in an interlaced format (e.g., 1920 x 1080i), connect each top stack's **H Sync Output** signal (located on the **Program 2 Out Analog** connector) to the **Genlock** input on the bottom stack.

#### Note

Using a (customer supplied) VGA to 5xBNC breakout cable, the **H Sync Output** line is typically a white or gray cable.

### 10. Link Connections — in a widescreen application, the **Program Link** and **Source Link** connections are used to connect processors together, and bridge inputs and outputs for the proper “overlap” between projectors. In Chapter 3 of the **Encore Presentation System User's Guide**, refer to the “**Program and Source Link Connections**” section for details.

### 11. Power Connection — connect AC power cords to all Encore and peripheral equipment, and then to AC outlets.

### 12. System ID — Using the **Unit ID Selector**:

- a. On the first stack, set the ID of the bottom stack Processor to **1** (VP only). Set the ID of the top stack Processor to **2** (VP or VPx).

- b. On the second stack, set the ID of the bottom stack Processor to **3** (VP or VPx). Set the ID of the top stack Processor to **4** (VP or VPx).

**Important**

In each stack, the ID of the bottom stack Processor must *always* be lower than the ID of the top stack Processor. Remember that master units (ID#1 and ID#2) must be VP only, not VPx.

13. **Power On** — Refer to Chapter 6 of the **Encore Presentation System User's Guide** for all power on instructions.

## Technical Specifications

The following information is provided in this section:

- [VPx Input Specifications](#)
- [Output Specifications](#)
- [Physical and Electrical Specifications](#)
- [Communications Specifications](#)

### VPx Input Specifications

The table below lists VPx input specifications.

**Table 6.** Encore VPx Input Specifications

Input	Parameter	Specification
Via "Source Link" Input	Analog Video	RGBHV / RGBS / RGB computer video, YPbPr video (SD or HD), S-video, or Composite video
	SD and HDSI Video	Per SMPTE 259M-C (NTSC / PAL resolution) SMPTE 292M (HDTV)
	DVI	Per DDWG 1.0
	Input Resolutions	<ul style="list-style-type: none"> <li>• NTSC/PAL</li> <li>• Computer Resolutions VGA (640 x 480) through UXGA (1600 x 1200)</li> <li>• HDTV Resolutions up to 1920 x 1080 (720p, 1080i, 1080p)</li> <li>• 2048 x 1080p (Digital Cinema format)</li> <li>• Plasma Display Resolutions</li> </ul>
Native Resolution Background Channels (2 per M/E board)	Analog Inputs	RGBHV computer video on DVI-I connector
	DVI Input	Per DDWG 1.0 on DVI-I connector
	Input Resolutions	<ul style="list-style-type: none"> <li>• Computer Resolutions: SVGA (800 x 600) through UXGA (1600 x 1200)</li> <li>• HDTV Resolutions (720p, 1080p)</li> <li>• 2048 x 1080p (Digital Cinema format)</li> <li>• Plasma Display Resolutions</li> </ul>
Downstream Key Input (1 per Encore Video Processor)	Analog Inputs	RGBHV computer video on DVI-I connector
	DVI Input	Per DDWG 1.0 on DVI-I connector
	Input Resolutions	<ul style="list-style-type: none"> <li>• Computer Resolutions: SVGA (800 x 600) through UXGA (1600 x 1200)</li> <li>• HDTV Resolutions (720p, 1080p)</li> <li>• 2048 x 1080p (Digital Cinema format)</li> <li>• Plasma Display Resolutions</li> </ul>

## Output Specifications

The table below lists VPx output specifications.

**Table 7.** Encore VPx Output Specifications

Output	Parameter	Specification
Preview Output	Analog Outputs	RGBHV / RGBS / RGsB, YPbPr video (SD or HD), on 15-pin HD connectors
	DVI Output	Per DDWG 1.0 on DVI-I connector
Program Output 1	Analog Outputs	RGBHV / RGBS / RGsB, YPbPr video (SD or HD), on 15-pin HD connectors
	DVI Output	Per DDWG 1.0 on DVI-I connector
	HDSI Output	Per SMPTE 259M-C (NTSC / PAL resolution) SMPTE 292M (HDTV) on BNC connector (Program Out)
Program Output 2	Function	This output can be programmed to serve as a second buffered program output or a monitoring program output
	Analog Outputs	RGBHV / RGBS / RGsB, YPbPr video (SD or HD), on 15-pin HD connectors
	DVI Output	Per DDWG 1.0 on DVI-I connector
	HDSI Output	Per SMPTE 259M-C (NTSC / PAL resolution) SMPTE 292M (HDTV) on BNC connector (Program Out)
Output Resolutions		<ul style="list-style-type: none"> <li>• Computer Resolutions VGA (640 x 480) through UXGA (1600 x 1200)</li> <li>• HDTV Resolutions up to 1920 x 1080 (720p, 1080i, 1080p)</li> <li>• 2048 x 1080 (Digital Cinema format)</li> <li>• Plasma Display Resolutions</li> </ul>
Delay	50Hz	30ms max.
	60Hz	25ms max.

## Physical and Electrical Specifications

The table below lists VPx physical and electrical specifications.

**Table 8.** Encore VPx Physical and Electrical Specifications

Parameter	Detail	Specification
Power	VPx	120-240 VAC - 50/60 Hz., Auto-selecting 1.0A maximum
Mechanical	VPx	3 RU Rackmount Chassis
		H: 5.25 inches (13.34 cm)
		W: 17.00 inches (43.18 cm)
		D: 15.00 inches (38.10 cm)
Weight	VPx	1 M/E: 27.8 lbs (12.61 kg)
		2 M/E: 30.5 lbs (13.83 kg)
		3 M/E: 33.2 lbs (15.05 kg)
Temperature		0-40 degrees C
Humidity		0-95% non-condensing

## Communications Specifications

The table below lists VPx communications specifications.

**Table 9.** Encore VPx Communications Specifications

Parameter	Detail	Specification
RS-232	Video Processor	DB-9 Female, DCE, 115k Baud
Ethernet	Video Processor	RJ-45, 10/100 Mbps Autosense

## Free Manuals Download Website

<http://myh66.com>

<http://usermanuals.us>

<http://www.somanuals.com>

<http://www.4manuals.cc>

<http://www.manual-lib.com>

<http://www.404manual.com>

<http://www.luxmanual.com>

<http://aubethermostatmanual.com>

Golf course search by state

<http://golfingnear.com>

Email search by domain

<http://emailbydomain.com>

Auto manuals search

<http://auto.somanuals.com>

TV manuals search

<http://tv.somanuals.com>