

MULTICOM[®] PRO MDX4400

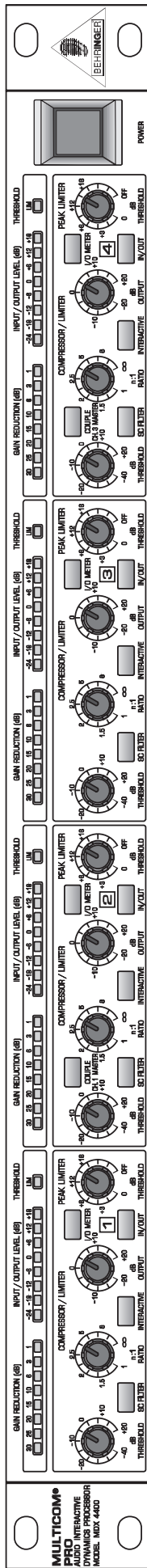

User's Manual

Version 1.3 April 2001

ENGLISH



www.behringer.com

SAFETY INSTRUCTIONS

CAUTION: To reduce the risk of electric shock, do not remove the cover (or back). No user serviceable parts inside; refer servicing to qualified personnel.



WARNING: To reduce the risk of fire or electric shock, do not expose this appliance to rain or moisture.



This symbol, wherever it appears, alerts you to the presence of uninsulated dangerous voltage inside the enclosure—voltage that may be sufficient to constitute a risk of shock.



This symbol, wherever it appears, alerts you to important operating and maintenance instructions in the accompanying literature. Read the manual.

DETAILED SAFETY INSTRUCTIONS:

All the safety and operation instructions should be read before the appliance is operated.

Retain Instructions:

The safety and operating instructions should be retained for future reference.

Heed Warnings:

All warnings on the appliance and in the operating instructions should be adhered to.

Follow instructions:

All operation and user instructions should be followed.

Water and Moisture:

The appliance should not be used near water (e.g. near a bathtub, washbowl, kitchen sink, laundry tub, in a wet basement, or near a swimming pool etc.).

Ventilation:

The appliance should be situated so that its location or position does not interfere with its proper ventilation. For example, the appliance should not be situated on a bed, sofa, rug, or similar surface that may block the ventilation openings, or placed in a built-in installation, such as a bookcase or cabinet that may impede the flow of air through the ventilation openings.

Heat:

The appliance should be situated away from heat sources such as radiators, heat registers, stoves, or other appliances (including amplifiers) that produce heat.

Power Source:

The appliance should be connected to a power supply only of the type described in the operating instructions or as marked on the appliance.

Grounding or Polarization:

Precautions should be taken so that the grounding or polarization means of an appliance is not defeated.

Power-Cord Protection:

Power supply cords should be routed so that they are not likely to be walked on or pinched by items placed upon or against them, paying particular attention to cords and plugs, convenience receptacles and the point where they exit from the appliance.

Cleaning:

The appliance should be cleaned only as recommended by the manufacturer.

Non-use Periods:

The power cord of the appliance should be unplugged from the outlet when left unused for a long period of time.

Debris and Liquid Entry:

Care should be taken that debris and/or liquids do not enter the enclosure through openings.

Damage Requiring Service:

The appliance should be serviced by qualified service personnel when:

- The power supply cord or the plug has been damaged; or
- Debris or liquid has entered the appliance; or
- The appliance has been exposed to rain; or
- The appliance does not appear to operate normally or exhibits a marked change in performance; or
- The appliance has been dropped, or the enclosure damaged.

Servicing:

The user should not attempt to service the appliance beyond that which is described in the operating instructions. All other servicing should be referred to qualified service personnel.

FOREWORD

Dear Customer,

Welcome to the team of MULTICOM PRO users and thank you very much for expressing your confidence in BEHRINGER products by purchasing this unit.

It is one of my most pleasant tasks to write this letter to you, because it is the culmination of many months of hard work delivered by our engineering team to reach a very ambitious goal: making an outstanding device better still. The MULTICOM has for quite a long time been a standard tool used by numerous studios and PA rental companies. The task to improve one of our best-selling products certainly meant a great deal of responsibility, which we assumed by focusing on you, the discerning user and musician. It also meant a lot of work and night shifts to accomplish this goal. But it was fun, too. Developing a product usually brings a lot of people together, and what a great feeling it is when everybody who participated in such a project can be proud of what we've achieved.

It is our philosophy to share our joy with you, because you are the most important member of the BEHRINGER family. With your highly competent suggestions for new products you've greatly contributed to shaping our company and making it successful. In return, we guarantee you uncompromising quality (manufactured under the ISO9000 certified management system) as well as excellent technical and audio properties at an extremely favorable price. All of this will enable you to fully unfold your creativity without being hampered by budget constraints.

We are often asked how we can make it to produce such high-grade devices at such unbelievably low prices. The answer is quite simple: it's you, our customers! Many satisfied customers means large sales volumes enabling us to get better conditions of purchase for components, etc. Isn't it only fair to pass this benefit back to you? Because we know that your success is our success, too!

I would like to thank all people whose help on "Project MULTICOM PRO" has made it all possible. Everybody has made very personal contributions, starting from the designers of the unit via the many staff members in our company to you, the user of BEHRINGER products.

My friends, it's been worth the trouble!

Thank you very much,

A handwritten signature in black ink, appearing to read 'U. Behringer', with a long horizontal flourish extending to the right.

Uli Behringer

MULTICOM[®] PRO

Interactive 4-channel compressor/limiter/peak limiter of the reference class

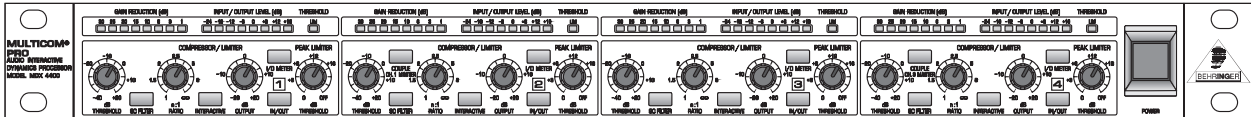

- ▲ IKA (Interactive Knee Adaptation) compressor concept combines the advantages of “hard knee” and “soft knee” characteristics
- ▲ Switchable highpass filter in control signal path avoids low-frequency signals from dominating compressor action
- ▲ Compression characteristics switchable between IKA and “hard knee” characteristics
- ▲ IGC (Interactive Gain Control) peak limiter combines clipper with program limiter circuits
- ▲ Extremely low-noise operational amplifiers and high-grade VCA's
- ▲ High-quality detent potentiometers and backlit switches
- ▲ Stereo Couple function for channels 1/2 and 3/4 selectable with real totaling of RMS output
- ▲ Accurate 8-digit LED meters for input level, output level and gain reduction
- ▲ Operating level switchable from +4 dBu to -10 dBV
- ▲ Servo-balanced inputs and outputs featuring 1/4" jacks and XLR connectors
- ▲ Manufactured under ISO9000 certified management system

TABLE OF CONTENT

1. INTRODUCTION	6
1.1 Technical Background	7
1.1.1 Noise As A Physical Phenomenon	7
1.1.2 What Are Audio Dynamics?	7
1.1.3 Compressors/Limiters	9
2. THE DESIGN CONCEPT	10
2.1 High Quality Components And Design	10
2.2 Inputs And Outputs	10
2.2.1 Balanced Inputs And Outputs	10
3. INSTALLATION	11
3.1 Rack Mounting	11
3.2 Mains Voltage	11
3.3 Audio Connections	11
3.4 Selecting The Operating Level	12
4. CONTROLS	13
4.1 The Front Panel Control Elements	13
4.4 Rear Panel Control Elements Of The MULTICOM PRO	15
5. APPLICATIONS	16
5.1 Compression/Leveling/Limiting/Clipping	16
5.2 Compressor Section	17
5.2.1 Initial Settings For The Compressor Section	18
5.2.2 The MULTICOM PRO As A Sound Effects Unit	18
5.2.3 The "Muffling" Effect Of A Compressor	18
5.3 Peak Limiter Section	19
5.3.1 Initial Settings For The Peak Limiter Section	19
6. SPECIAL APPLICATIONS	20
6.1 Using The MULTICOM PRO For Recording And Cassette Duplication	20
6.1.1 The MULTICOM PRO In Digital Recording And Sampling	20
6.1.2 The MULTICOM PRO In Mastering	20
6.2 The MULTICOM PRO as a protective device	20
6.2.1 Protection Of A System With A Passive Crossover	21
6.2.2 Protection Of A System With An Active Crossover	21
6.2.3 Improving The Sound Of A Processor System	21
6.3 The MULTICOM PRO In Broadcast	22
7. SPECIFICATIONS	23
8. WARRANTY	25

1. INTRODUCTION

In purchasing the MULTICOM PRO, you have acquired an extremely efficient and universal dynamics processor. The unit was particularly designed for those applications most frequently used in practice. Despite the extremely complex internal circuitry, the unit has a control surface which is clearly laid out and easy to understand. With the MULTICOM PRO, BEHRINGER have developed an innovative and easy-to-use dynamics processor which meets the high demands that are made on such a device both in live and studio applications. The unit's most outstanding features are the precision and flexibility of its functions.

Quad compressor/limiters are actually not a new invention. Usually, four simple compressor sections are packed into one enclosure, representing however a compromise in terms of operation and functionality. An excessive number of controls complicates the operation of the unit and a lack of control functions restricts the unit's range of application.

The BEHRINGER MULTICOM PRO is a compact quad compressor/limiter based on the successful BEHRINGER Interactive Technology. Integrated AUTO processors automatically derive attack and release times from the programme material and provide you with transparent and "inaudible" compression. In 1 RU package the unit consists of four independent high-precision compressor sections with sidechain filters and four peak limiters, each offering all the required controls.

With rack space at a premium both in the studio and in sound reinforcement, the MULTICOM PRO's unique high density design and clean uncluttered layout makes it a truly useful audio tool for all applications. The MULTICOM PRO is a perfect and extremely cost-effective solution for all your multi-channel dynamic applications.

Advanced BEHRINGER Technology

Compared to its predecessors, the MULTICOM PRO offers several advanced features such as the extended LED meters, the sidechain filter, the controllable peak limiter per channel and the couple function for two channels. Additionally, we have succeeded in refining the audio properties as well as the circuit topology.

For the first time, the MULTICOM PRO MDX 4400 uses SMD technology (Surface Mounted Device). These sub-miniature components known from aerospace technology allow for an extreme packing density, plus improve the unit's reliability.

IKA (Interactive Knee Adaptation) Compressor

Our proven IKA (Interactive Knee Adaptation) circuit successfully combines the concept of a "hard knee" compressor with the characteristics of a "soft knee" approach. This program-dependent regulation scheme forms the prerequisite both for "inaudible" and musical program compression and for creative and highly effective dynamics processing.

With its IKA circuit the MULTICOM PRO is capable of delivering outstanding musical results both in studio and live PA applications.

Additionally, the MULTICOM PRO's sidechain filter allows for limiting the influence low-frequency signal portions usually have on the control logic, so that the compression ratio is mainly determined by those frequencies that are essential to the loudness perceived by the listener—the midrange frequencies.

AUTO COMPRESSOR Circuitry

The response of a compressor and the quality of dynamics processing largely depend on the control times, i.e., the attack and release functions. In particular, in the field of "musical" compression of complex composite signals, programme-dependent control times are necessary. The interactive AUTO processor derives the attack and release times automatically from the programme material, a function that avoids misadjustment of the control times, which is a problem often encountered in conventional designs. In addition the AUTO processor allows for a high compression of the dynamic range without any audible side effects, such as "pumping", "breathing" etc.

IGC (Interactive Gain Control) Peak Limiter

A further remarkable feature of the BEHRINGER MULTICOM PRO is the IGC (Interactive Gain Control) Limiter, an intelligent combination of a clipper and a program limiter. Above an adjustable threshold the peak limiter begins to function and restricts signal peaks radically (clipper). If however, the threshold of the limiter was surpassed for more than a few milliseconds, the IGC circuit automatically kicks in and reduces the level of the

overall output signal so that no audible distortion occurs (program limiter). After the level falls below the threshold, the signal returns to the original value after a period of about 1 second. This IGC circuit proves to be extremely valuable as much for live work (loudspeaker protection) as for digital situations, where any extreme signal peaks would exceed the maximum headroom and therefore would cause severe problems.

 **The following instructions should initially familiarize you with the special terms used, so that you can get to know all the functions of the unit. After you have read the instructions carefully, please put them away safely, so that you can refer to them again if necessary.**

1.1 Technical Background

By employing current modern analogue technology it is possible to manufacture audio equipment with a dynamic range of up to 125 dB. In contrast to analogue techniques, the dynamic range of digital equipment is approximately 25 dB less. With conventional record and tape recorder technology, as well as broadcasting, this value is further reduced. Generally, dynamic restrictions are due to noisy storage in transmission media and also the maximum headroom of these systems.

1.1.1 Noise As A Physical Phenomenon

All electrical components produce a certain level of inherent noise. Current flowing through a conductor leads to uncontrolled random electron movements. For statistical reasons, this produces frequencies within the whole audio spectrum. If these currents are highly amplified, the result will be perceived as noise. Since all frequencies are equally affected, we term this white noise. It is fairly obvious that electronics cannot function without components. Even if special low-noise components are used, a certain degree of basic noise cannot be avoided.

This effect is similar when replaying a tape. The non-directional magnetic particles passing the replay head can also cause uncontrolled currents and voltages. The resulting sound of the various frequencies is heard as noise. Even the best possible tape biasing can “only” provide signal-to-noise ratios of about 70 dB, which is not acceptable today since the demands of listeners have increased. Due to the laws of physics, improving the design of the magnetic carrier is impossible using conventional means.

1.1.2 What Are Audio Dynamics?

A remarkable feature of the human ear is that it can detect the most wide ranging amplitude changes—from the slightest whisper to the deafening roar of a jet-plane. If one tried to record or reproduce this wide spectrum of sound with the help of amplifiers, cassette recorders, records or even digital recorders (CD, DAT etc.), one would immediately be restricted by the physical limitations of electronic and acoustic sound reproduction technology.

The usable dynamic range of electro-acoustic equipment is limited as much at the low end as at the high end. The thermal noise of the electrons in the components results in an audible basic noise floor and thus represents the bottom limit of the transmission range. The upper limit is determined by the levels of the internal operating voltages; if they are exceeded, audible signal distortion is the result. Although in theory, the usable dynamic range sits between these two limits, it is considerably smaller in practice, since a certain reserve must be maintained to avoid distortion of the audio signal if sudden level peaks occur. Technically speaking, we refer to this reserve as “headroom”—usually this is about 10 - 20 dB. A reduction of the operating level would allow for greater headroom, i.e. the risk of signal distortion due to level peaks would be reduced. However, at the same time, the basic noise floor of the program material would be increased considerably.

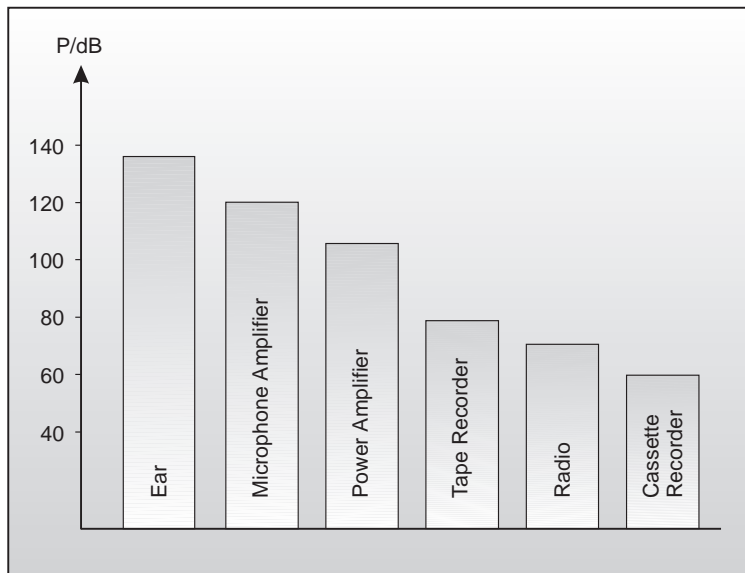

Fig. 1.1: The dynamic range capabilities of various devices

It is therefore useful to keep the operating level as high as possible without risking signal distortion in order to achieve optimum transmission quality.

It is possible to further improve the transmission quality by constantly monitoring the program material with the aid of a volume fader, which manually levels the material. During low passages the gain is increased, during loud passages the gain is reduced. Of course it is fairly obvious that this kind of manual control is rather restrictive; it is difficult to detect signal peaks and it is almost impossible to level them out. Manual control is simply not fast enough to be satisfactory.

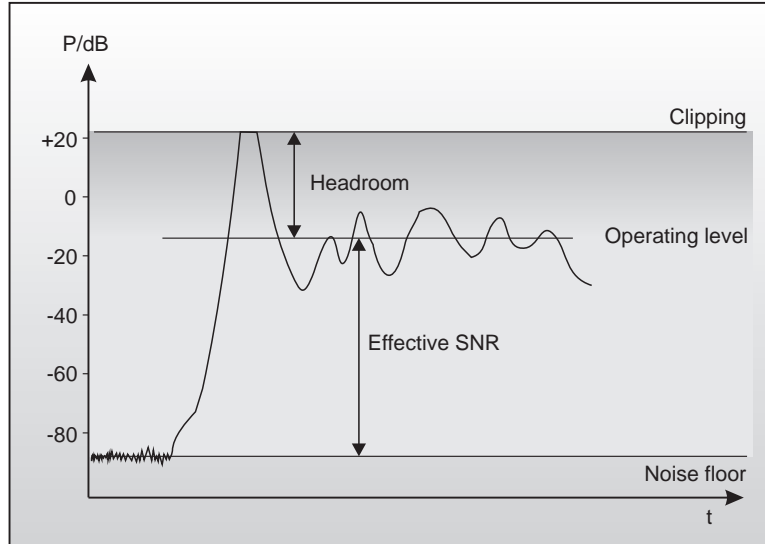

Fig. 1.2: The interactive relationship between the operating level and the headroom

The need therefore arises for a fast acting automatic gain control system which will constantly monitor the signals and which will always adjust the gain to maximize the signal-to-noise ratio without incurring signal distortion. This device is called a compressor or limiter. This system is a part of the BEHRINGER MULTICOM PRO.

1.1.3 Compressors/Limiters

By measuring the dynamic range of musical instruments in live recording situations, you will find that extreme amplitudes occur which often lead to overload in subsequent signal processing equipment. Especially in broadcasting and record cutting techniques, these signal peaks can lead to heavy distortion. To avoid this kind of distortion or, for example, to avoid loudspeakers being damaged by overload, compressors or limiters are used.

The principal function used in these devices is dependent on an automatic gain control as mentioned in the previous section, which reduces the amplitude of loud passages and therefore restricts the original dynamics to a desired range. This application is particularly useful in microphone recording techniques, to compensate for level changes which are caused by varying microphone distances. Although compressors and limiters perform similar tasks, one essential point makes them different: limiters abruptly limit the signal above a certain level, while compressors control the signal "gently" over a wider range. A limiter continuously monitors the signal and intervenes as soon as the level exceeds a user-adjustable threshold. Any signal exceeding this threshold will be immediately returned to the adjusted level.

A compressor also monitors the program material continuously and has a certain threshold level. With compression, in contrast to the action of a limiter, signals are not reduced in level abruptly once the threshold has been exceeded, but are returned to the threshold gradually. The signal is reduced in gain, relative to the amount the signal exceeds this point.

Generally, threshold levels for compressors are set below the normal operating level to allow for the upper dynamics to be musically compressed. For limiters, the threshold point is set above the normal operating level in order to provide reliable signal limiting, to protect subsequent equipment from signal overload.

2. THE DESIGN CONCEPT

2.1 High Quality Components And Design

The philosophy behind BEHRINGER products guarantees a no-compromise circuit design and employs the best choice of components. The operational amplifiers NJM4580 which are used in the MULTICOM PRO, are exceptional. They boast extreme linearity and very low distortion characteristics. The most important aspect of the MULTICOM PRO design is a radical VCA implementation which results in outstanding technical specification and excellent performance. To complement this design the choice of components includes high tolerance resistors and capacitors, detent potentiometers and several other stringently selected elements.

For the first time, the MULTICOM PRO MDX 4400 uses SMD technology (Surface Mounted Device). These sub-miniature components known from aerospace technology allow for an extreme packing density, plus the unit's reliability could be improved. Additionally, the unit is manufactured under ISO9000 certified management system.

2.2 Inputs And Outputs

2.2.1 Balanced Inputs And Outputs

As standard, the BEHRINGER MULTICOM PRO is installed with electronically servo-balanced inputs and outputs. The new circuit design features automatic hum and noise reduction for balanced signals and thus allows for trouble-free operation, even at high operating levels. Externally induced mains hum etc. will be effectively suppressed. The automatic servo-function recognizes the presence of unbalanced connectors and adjusts the nominal level internally to avoid level differences between the input and output signals (correction 6 dB).

3. INSTALLATION

Your BEHRINGER MULTICOM PRO was carefully packed in the factory and the packaging was designed to protect the unit from rough handling. Nevertheless, we recommend that you carefully examine the packaging and its contents for any signs of physical damage, which may have occurred in transit.

Please also take the time to complete and return the warranty card within 14 days of the date of purchase, otherwise you will lose the right to the extended warranty. Or simply use our online registration under www.behringer.com.

 **If the unit is damaged, please do not return it to us, but notify your dealer and the shipping company immediately, otherwise claims for damage or replacement may not be granted. Shipping claims must be made by the consignee.**

3.1 Rack Mounting

The BEHRINGER MULTICOM PRO fits into one standard 19" rack unit of space (1 3/4"). Please allow at least an additional 4" depth for the connectors on the back panel. Be sure that there is enough air space around the unit for cooling and please do not place the MULTICOM PRO on high temperature devices such as power amplifiers etc. to avoid overheating.

3.2 Mains Voltage

Before you connect your MULTICOM PRO to the mains, please make sure that your local voltage matches the voltage required by the unit! The fuse holder on the female mains connector has 3 triangular markers, with two of these triangles opposing each other. Your MULTICOM PRO is set to the operating voltage printed next to these markers, and can be set to another voltage by turning the fuse holder by 180°. **CAUTION: this instruction does not apply to export models exclusively designed, e.g. for 115 V operation!**

3.3 Audio Connections

The audio inputs and outputs on the BEHRINGER MULTICOM PRO are fully balanced. If possible, connect the unit to other devices in a balanced configuration to allow for maximum interference immunity.

 **Please ensure that only qualified persons install and operate the VIRTUALIZER. During installation and operation the user must have sufficient electrical contact to earth. Electrostatic charges might affect the operation of the MULTICOM PRO!**

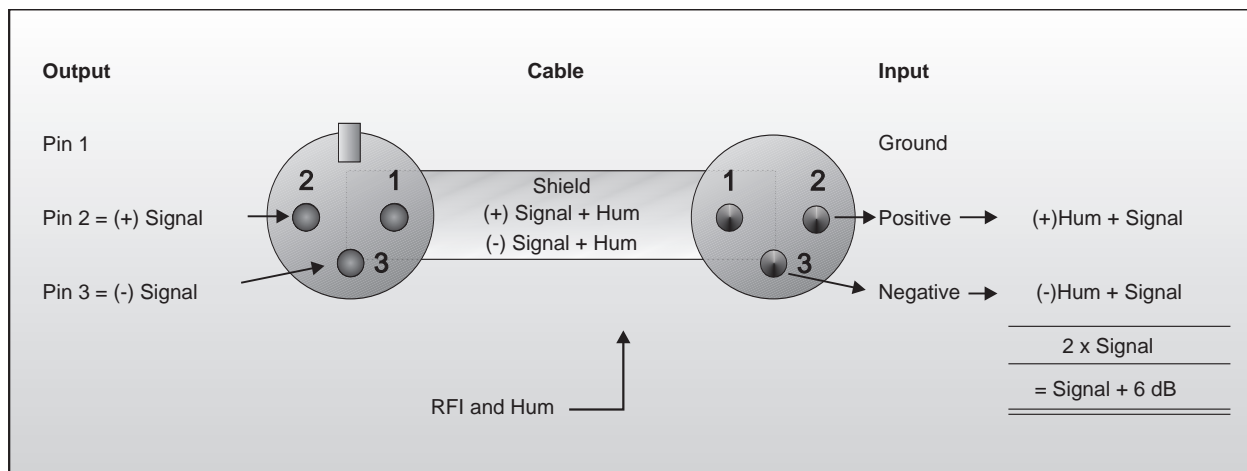

Fig. 3.1: Compensation of interference with balanced connections

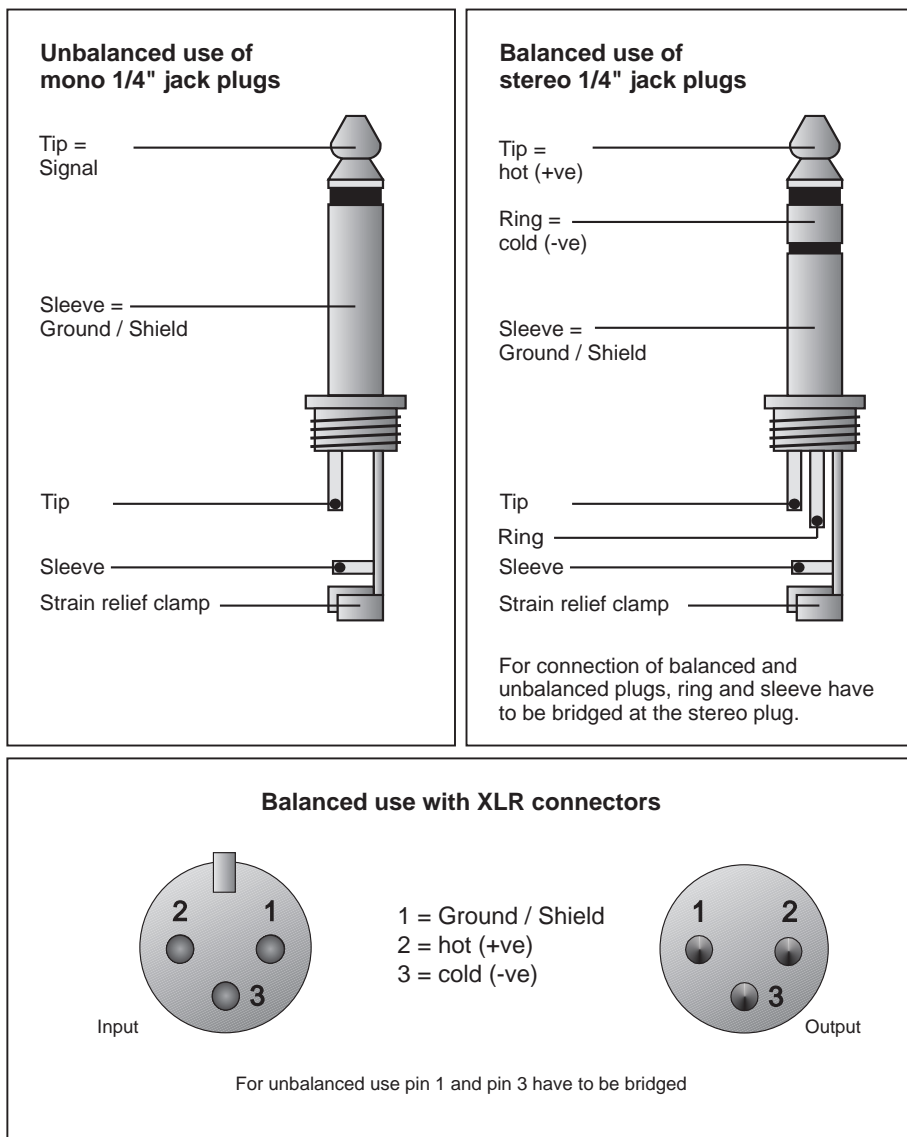

Fig. 3.2: Different plug types

⚠ Never use unbalanced XLR connections with microphone cables, as this would short-circuit any phantom power transmitted over these cables!

3.4 Selecting The Operating Level

With the "Operating Level" switch on the rear of the BEHRINGER MULTICOM PRO you can adjust the internal operating level of the unit. Thus, the MULTICOM PRO can be adapted perfectly to various levels (e.g. both the typical home recording level of -10 dBV and the professional level of +4 dBu). The level meters are referenced automatically to the selected level, i.e. an optimum operating range of the meters will always be ensured.

4. CONTROLS

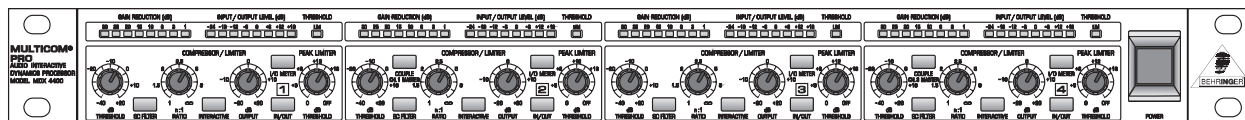

Fig. 4.1: MULTICOM PRO front panel

The BEHRINGER MULTICOM PRO has four identical channels. Each channel is equipped with 4 backlit push-buttons, 4 rotary controls and 17 LED's. The COUPLE switches are for stereo operation of two channels.

4.1 The Front Panel Control Elements

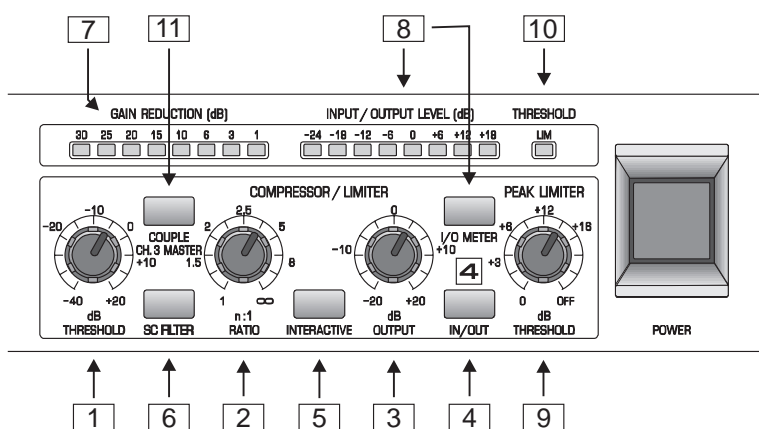



Fig. 4.2: Control elements on the front panel

- 1 The *THRESHOLD* control sets the threshold point for the compressor section. It has a range of -40 to +20 dB. If the channel is switched to *INTERACTIVE* mode (Interactive Knee Adaptation), a “Soft Knee” characteristic is applied to the signal exceeding the threshold point by a maximum of 10 dB. Above 10 dB, the signal would experience “Hard Knee” compression.
 - 2 The *RATIO* control determines the ratio between the input and output level for all signals exceeding the threshold point. If the *INTERACTIVE* mode is used, this control determines the ratio between input and output levels for signals exceeding the threshold point by more than 10 dB. The control range can be adjusted from 1:1 to ∞ :1.
 - 3 The *OUTPUT* control allows for the increase or decrease of the output signal by a maximum of 20 dB. Thus, a level loss due to the compression or limiting process can be compensated for.
- Please note when using the *THRESHOLD* control of the Peak Limiter section, that the *OUTPUT* control of the Compressor section precedes the Peak Limiter section. If the *OUTPUT* control is set too high, this can result in continuous peak limiting (see item 9 “*THRESHOLD* control”).**
- 4 The *IN/OUT* switch activates the corresponding channel. This switch acts as a so-called “hard-bypass” switch, which means that when the switch is *OUT*, the input jack is directly linked to the output jack. Normally, this switch is used to perform a direct A/B comparison between the unprocessed and the compressed or limited signals.
 - 5 Press the *INTERACTIVE* switch to change from “Hard Knee” to IKA characteristics. IKA provides a very subtle and musical compression of the program material and should therefore be used whenever compression should be more or less inaudible.
 - 6 The *SC FILTER* switch activates a highpass filter in the sidechain path and thus limits the influence of low frequencies on the MULTICOM PRO’s control processes.

-
- 7 The 8-digit *GAIN REDUCTION* meter indicates how effectively the gain is reduced by the compressor, within a range from 1 to 30 dB.
- 8 The 8-digit *INPUT/OUTPUT LEVEL* meter informs you—depending on the setting of the *I/O METER* switch—about the current input or output level, within a range from -24 to +18 dB. When the switch is set to *IN* (not engaged), the meter reads the input level, when it is *OUT*, the output level is displayed. The meter is referenced to the operating level (-10 dBV or +4 dBu) adjusted with the *OPERATING LEVEL* switch on the back.
- 9 The peak limiter limits the signal to a level adjusted with the *THRESHOLD* control. Owing to its extremely fast response (“Zero” attack), the limiter is capable of limiting signal peaks without audible distortion. Whenever the signal is limited for more than 20 ms, the overall level is reduced for about 1 second to avoid heavy and thus audible signal distortion.
-  **When you use the peak limiter as a protective device against signal peaks, the *THRESHOLD* control should be set in combination with the *OUTPUT* control in the compressor section so that the peak limiter responds rarely or not at all. Thus, only real signal peaks will activate the limiter circuit. However, to produce creative sound effects, the peak limiter can be deliberately set to lower levels.**
- 10 The *LIM LED* lights up as soon as the limiter function is activated.
- 11 The MULTICOM PRO converts two channels to stereo mode by engaging one of the *COUPLE* switches, where the left of the channels assumes the control of both audio channels, i.e. the control signal of channel 2 is replaced with that of channel 1. By pressing the *COUPLE* switch, you override all the controls and switches of channel 2 (or 4) with the exception of the *IN/OUT* and *SC Filter* switches as well as the peak limiter’s *THRESHOLD* control. The controls of channel 1 (or 3) take over all functions of channel 2 (or 4).

4.4 Rear Panel Control Elements Of The MULTICOM PRO

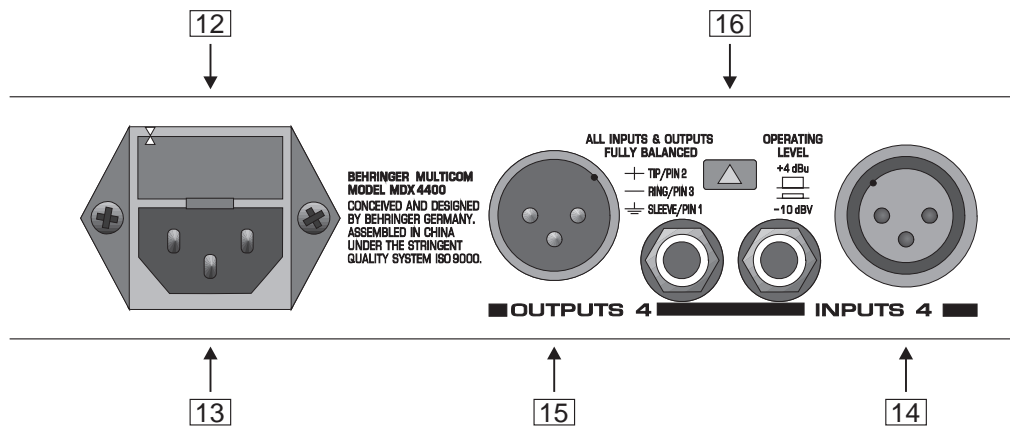

Fig. 4.5: Control elements of the rear panel

- 12** **FUSE HOLDER / VOLTAGE SELECTOR.** Please make sure that your local voltage matches the voltage indicated on the unit, before you attempt to connect and operate the MULTICOM PRO. Blown fuses may only be replaced by fuses of the same type and rating.
- 13** **MAINS CONNECTION.** Use the enclosed power cord to connect the unit to the mains. Please also note the instructions given in the "INSTALLATION" chapter.
- 14** **AUDIO IN.** These are the audio inputs of your MULTICOM PRO, available both as balanced 1/4" jack and XLR connectors.
- 15** **AUDIO OUT.** These are the audio outputs of your MULTICOM PRO. Matching phone jack and XLR connectors are wired in parallel.
- 16** With the **OPERATING LEVEL** switch you can adapt the MULTICOM PRO to various operating levels, i.e. you can select both the -10 dBV home recording level and the professional studio level of +4 dBu. The level meters are referenced automatically to the selected level, i.e. an optimum operating range of the meters will always be ensured.

5. APPLICATIONS

In this section, several typical applications of the BEHRINGER MULTICOM PRO are discussed. The following basic settings can resolve most dynamic problems. They are the ideal starting point. Please take the time to study the application examples carefully, in order to be able to make full use of the MULTICOM PROs capabilities in the future.

Main Applications And Initial Settings

The main applications of the BEHRINGER MULTICOM PRO can be divided into two categories: The compressor section is used to compress the program material and to create special effects and unusual sounds, which are used for recording and musical performance. The subsequent Peak Limiter section is designed to protect loudspeakers, tape recorders, transmitters etc. from being overloaded.

5.1 Compression/Leveling/Limiting/Clipping

Now that the functions of the individual sections have been clearly explained, we would like to acquaint you with more terms and relationships of the dynamics process.

Compression

A compressor converts a large dynamic level into a restricted range. The extent of the resulting dynamic level is dependent on the threshold, attack, release and ratio settings. As it is the desired effect of a compressor to increase a low level signal, generally the threshold is set low. The "inaudible" compression mode requires fast attack and release times and low ratios. The faster the chosen control times and the higher the compression ratio, the greater the effect on the short term dynamics. This fact is often used to achieve audible and creative sound effects.

Leveling

The leveling mode is used to keep output level constant, i.e. to compensate for long term gain changes, without affecting the short term dynamics. Normally, the threshold is set quite low in order to be able to increase low level signals. Leveling requires slow attack and release times, combined with a high ratio. Because of the very slow response time, leveling has no effect on signal peaks or short term changes in average level.

Limiting

The limiting function requires a fast attack time and a high ratio and release time setting, which is dependent on the specific use and the desired sound effect. As it is usually the task of a limiter to limit only high signal peaks, the threshold is usually set at a high level. The dynamics are reduced dependent on the ratio setting and the degree by which the threshold point was exceeded. If the attack time is adjusted to control only the average level without affecting signal peaks above the threshold, this is referred to as the program limiter. For this purpose the attack time will be set above 20 ms. If the attack time is further reduced in order to also control signal peaks, this is defined as the peak limiter.

Clipping

In contrast to the two previously mentioned limiters, the clipping mode features infinitely fast control times, an infinite compression ratio and creates an unsurpassable barrier ("brickwall") for all signals above a certain level. To be able to control the signal peaks, the clipping function radically cuts signals above the threshold, without affecting the amplitude of the original signal. If used in normal applications, this function remains inaudible and under certain circumstances it can even lead to an improved sound, because cutting the transients creates artificial harmonics. If misused, clipping can cause very obvious and distasteful distortion, which in an extreme manner, will convert the signal's waveform into a square wave signal. This effect is often produced in guitar distortion devices ("fuzz boxes").

5.2 Compressor Section

The task of a compressor is to reduce the dynamic range of program material and to control the overall level. The extensive controls of the Compressor section, provide a great range of dynamic effects: from musical and soft compression to limiting signal peaks, right up to extreme and effective compression of the overall dynamics. For example, a low ratio and very low threshold setting can be used to achieve soft and musical processing of the general dynamics of the program material.

Higher ratios, together with low threshold settings, create relatively constant volume (leveling) for instruments and vocals. High threshold levels generally limit the overall level of a program. Ratios greater than 6:1 effectively prevent the output level from significantly exceeding the threshold point (provided that the OUTPUT control is in the 0 dB position).

Please note that the compression of the entire program material (achieved by low threshold settings) sounds less natural with higher ratio settings. Ratio settings in the range of 4:1 and lower, effect the dynamics of the program material less and are often used to compress the sound of a bass guitar, a snare drum or a vocal. Sensitive and moderate settings are generally used in mixing and for leveling of program material in broadcast.

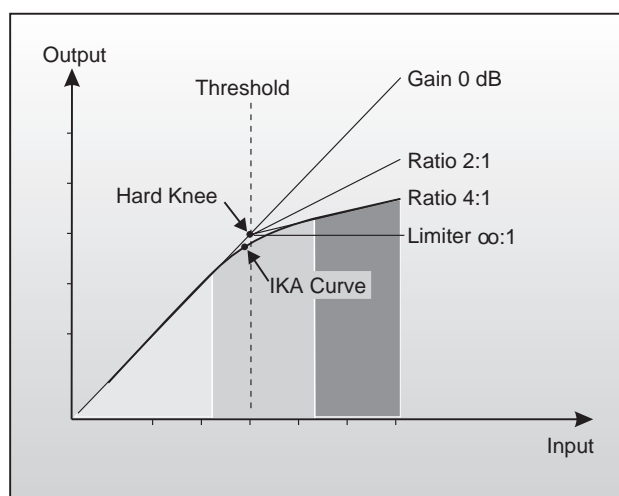

Fig. 5.1: IKA characteristic of the compressor section

The new IKA (Interactive Knee Adaptation) circuit prevents aggressive compression, created by high ratios, from sounding too unnatural. This is achieved with an interactive control function, which begins above the threshold level and introduces a “Soft Knee” curve characteristic in the range up to 10 dB above the threshold point. Beyond this range, the signal is subjected to linear (“Hard Knee”) compression.

👉 With the threshold control completely turned to the right, the threshold value is +20 dB. Since such a value will not be reached in practice, you can use it to disable the compressor section and work exclusively with the limiter circuits.

5.2.1 Initial Settings For The Compressor Section

Control	Setting
IN/OUT switch	IN
INTERACTIVE switch	IN
SC FILTER switch	OUT
THRESHOLD control	+20 dB
RATIO control	3:1
OUTPUT control	0 dB

Tab. 5.1: Initial settings for the compressor section

Rotate the THRESHOLD control counterclockwise until an appropriate amount of gain reduction is indicated on the GAIN REDUCTION meter. This operation will be accompanied by an audible drop in output level. The OUTPUT control should now be turned clockwise to reinstate the output level. The level of the unprocessed and the processed signal can be compared by pressing the I/O METER switch and observing the INPUT/OUTPUT LEVEL meter.

Final adjustments of the RATIO control can then be made to suit your particular requirements. The experienced user will be in a position to specify parameters while in bypass mode and thus realize the effect before the unit is actually switched into operation. This is important in live situations, where a signal needs to be managed efficiently by the engineer, without the convenience of continual A/B comparison.

5.2.2 The MULTICOM PRO As A Sound Effects Unit

In the early 1960's, musicians began looking at the recording process as a way to create new sounds. The pumping effect which had been avoided by earlier engineers suddenly became fashionable and was utilized as a creative tool, laying the groundwork for many of the sounds which are now considered indispensable in contemporary music. The compressor is used in this role because you can hear it working, and control of the dynamic range is of secondary importance.

The BEHRINGER MULTICOM PRO, with its extensive range of functions, is well suited to this application. Sound effects of this kind can be achieved using "extreme" settings. To achieve this, set the THRESHOLD control to a fairly low level, the RATIO control to almost maximum to obtain the desired effect. Experiment with all the controls in order to get a feel of their function!

5.2.3 The "Muffling" Effect Of A Compressor

Quite often, compressors are sometimes accused of "muffling" the sound, whilst at the same time reducing the dynamics. This fact should be investigated further. Bass frequencies contain most of the energy within music and therefore cause the compressor to reduce the overall dynamics. If the music also contains high frequencies along with the bass frequencies, these are also reduced in level. This is the reason why: in an extremely compressed recording of drums, the cymbals and high-hats are acoustically swamped by the sound of the snare or the bass drum. The same effect is experienced when processing reverberated or ambient sounds. The solution commonly used to this basic problem is either to reduce the compression ratio or to slow down the attack time, so that the increasing high frequency transients pass through the compressor unhindered before the compressor takes effect.

The MULTICOM PRO MDX4400 offers a solution to this problem that is by much more elegant. The SC Filter switch allows you to activate a highpass filter in the control signal path of the compressor. This filter makes sure that midrange and treble range frequencies are taken into account to a greater extent, and that a low-frequency signal triggers less compression than a midrange/treble signal of comparable level. A major advantage of this design can be seen in the fact that the frequency response of the overall signal is not modified below the threshold adjusted with the Threshold control.

In pop music the dynamics of both kick drum and bass guitar are usually processed individually. The sidechain filter is therefore ideally suited to apply overall compression in the mixdown, to compress the music while increasing its loudness, but without having to accept the drawbacks described above.

Please note that we offer a whole series of high-grade equalizers and enhancers/exciter, which are perfect tools to give any dynamics-processed signal the finishing acoustic touch. Please ask for detailed information!

5.3 Peak Limiter Section

As a section of its own and independent of the remaining control functions, the peak limiter enables you to limit the maximum peak level on the MULTICOM PRO's output. It has been designed for use in combination with the compressor section. Independently of all compressor functions, you can protect subsequent devices against signal peaks, short-time overload and excess modulation (radio stations, etc.).

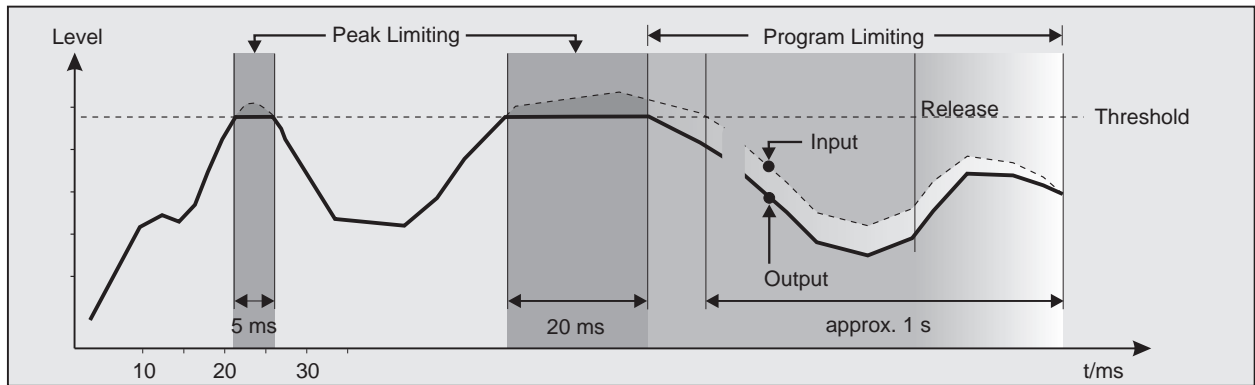

Fig. 5.3: IGC characteristic of the limiter section

The diagram illustrates the functioning of the IGC limiter. The solid graph represents the output signal, while the dashed graph above shows the input signal response. The areas between the graphs represent the amount of gain reduction (bright areas are “clipping areas”, i.e. signal peaks are radically cut off, dark areas show the effect of the program limiter). The limiter is activated when the adjusted threshold is exceeded for more than 20 ms, so as to limit audible clipping to a very short moment. About 1 s after the signals has dropped below the threshold again, the reduction is set to 0 dB, so that input and output signals are identical again (unity gain).

5.3.1 Initial Settings For The Peak Limiter Section

Control	Setting
THRESHOLD control	OFF

Tab. 5.3: Initial settings for the peak limiter section

The THRESHOLD control of the Peak Limiter sets the threshold level, so that subsequent units are protected from overloading. If the LIM comes on regularly or is on constantly, the OUTPUT control of the compressor section must be turned down, as this control sets the level of the signal, which is routed to the Peak Limiter section.

If this technique leads to an undesired drop in the overall level, it is recommended that you increase the compression: either, reduce the threshold level, or increase the compression ratio with the RATIO control. The OUTPUT control will compensate for a renewed drop in level.

6. SPECIAL APPLICATIONS

6.1 Using The MULTICOM PRO For Recording And Cassette Duplication

In the recording and duplication field the goal should always be to achieve an optimum recording level onto the recording media. Too low or too high recording levels lead to side effects such as noise, distortion etc. In mastering and multitrack recording, as well as in duplication, one should always take care to utilize the full dynamic range of the tape recorder, DAT recorder etc. Principally, it is possible to control the recording level by "riding" faders, which means with low level signals, the gain is increased, whereas the amplitude of high level signal is reduced. It is obvious that this method is insufficient because, especially in live recordings, the expected signal levels cannot be anticipated correctly. Especially with multitrack recordings, which are run under hectic circumstances, the signal level of all channels cannot be monitored and controlled at the same time. Generally, with manual control, it is not possible to achieve satisfying recording results.

An automatic gain control system achieves better and more constant results. Use the MULTICOM PRO by starting with the initial settings, and use its dynamic control functions in order to be able to drive an analogue, as well as a digital recording, up to the limit of its maximum dynamic range while remaining noise- and distortion-free.

6.1.1 The MULTICOM PRO In Digital Recording And Sampling

In an analogue recording, too low recording levels lead to an increased noise level, whereas too high levels will cause a compressed and "squashed" sound. In extreme cases, it will cause distortion due to tape saturation. In contrast to analogue, side effects in the digital field always become extremely audible: with decreasing level, a tape previously recorded with insufficient level loses resolution: the recording sounds "hard" and loses "atmosphere". With excessive level, the recording sounds harsh and heavily distorted. In order to avoid these effects, the Peak Limiter section of the MULTICOM PRO should be placed before for example a sampler. As a result of this process, a digital recording or a sampling event can be optimally set in level without any problem.

6.1.2 The MULTICOM PRO In Mastering

The mastering process is one of the most critical processing steps in recording. In this production step, it is the goal to achieve a "maximum level" copy of the recording, without any noise or distortion. In many applications it is further required to produce a high average volume. In the field of commercial media for example, this is apparent especially with records and cassettes which are processed with high average volumes. Quite often in these cases, dynamics suffer drastically, because the program material has been compressed and limited too heavily. Using the compressor and the Peak Limiter section of the MULTICOM PRO allows you to drastically increase the overall volume, without audibly affecting the dynamics.

Proceed as follows:

1. Limit the dynamics of the program material by 6 dB using the Peak Limiter section. By softly clipping just the transients, the real audio signal will not be limited, resulting in a higher headroom. The overall gain can now be increased by 6 dB, which leads to a higher volume. More than 6 dB should not be limited, otherwise side effects could become audible.
2. Therefore, in addition, you should also use compression. It is recommended that the compression is limited to the "first" 6 dB of the dynamic range only. A high threshold level in addition to the auto mode will give good results.

This effect is particularly noticeable with DAT recorders, whose level indicators achieve a response time of less than 1 ms. Set the DAT recorder at unity and now reduce the LEVEL control of the peak limiter until the LIM LED starts to illuminate. The "cut" signal peaks cause a reduced recording level of about 6 dB, which is visible on the level indicators of the DAT recorder. Now increase the recording level of the recorder back to unity. The result is a clearly louder recording without any loss of sound.

6.2 The MULTICOM PRO as a protective device

Sound system distortion is usually a result of amplifiers and loudspeakers being driven beyond their limitations by signals clipping. The signal limitations that occur lead to unpleasant distortion that is dangerous to the speakers.

A speaker diaphragm is required to accelerate, slow down, smoothly change direction and accelerate again in normal operation. Distorted operation (clipping) leads to instant acceleration, instant stop, change of direction and instant acceleration again. Since speaker diaphragms are subject to the laws of physics, they will not take this kind of punishment for long: the diaphragm will either break up or its voice coil may overheat.

In addition to the damage caused by sustained overload, the speaker may also be damaged by an occasional high level overload, e.g. the sound of a microphone falling onto a hard floor. Even if this type of transient does not destroy a speaker outright, it may damage the speaker surround in such a way, as to cause mechanical abrasion and future failure. It is recommended that you use the BEHRINGER MULTICOM PRO in order to protect the speaker. "Brick Wall" peak limiters are not normally necessary for PA systems, as amplifiers and loudspeakers are tolerant of short signal peaks.

Nevertheless, conventional limiters have to be generally driven far beyond the headroom limit of an amplifier, in order to limit the level and length of the transients responsible for overloading the system. The disadvantage of this principle is that the unit's full range cannot be completely used. If an increase in the average level of up to 3 dB is attained with the MULTICOM PRO's IGC Peak Limiter, this means that you effectively double the power amplification. The MULTICOM PRO can act in this way to convert a PA system of 5,000 Watts into a distortion free 10,000 Watts system. The following instructions will help you to integrate the unit into your system.

6.2.1 Protection Of A System With A Passive Crossover

If your sound system incorporates a passive crossover network (included in the loudspeaker case), insert the BEHRINGER MULTICOM PRO between your mixing console output and the power amplifier input. It is used as the last link in the chain preceding the power amp. Thus, you can effectively avoid the "technical knockout" of the midrange/tweeter range caused by high-energy bass signals! This statement, as paradox as it may seem at first, can be explained with the fact that especially low-frequency signals with high amplitudes can overload the power supplies in the amplifier(s). The resulting clipping (cutting off of signal peaks) produces high-energy distortion (upper harmonics), which is abruptly added to the midrange/tweeter signals. For this reason, "weak" power amps, in particular, must be protected by a limiter in their "input dynamics".

6.2.2 Protection Of A System With An Active Crossover

For systems using active crossovers, there are two ways to use the BEHRINGER MULTICOM PRO. The unit may be inserted between the console output and the crossover input. In this application, the BEHRINGER MULTICOM PRO will process the entire audio frequency spectrum.

Alternately, the MULTICOM PRO can be inserted between the output of an active crossover and the input of a power amplifier. In this application it will only affect a specific range of frequencies. This application is particularly suited to protect the most fragile components of a multi-way speaker system against harmful signal peaks. For example, when your tweeters keep on going up in smoke all the time, the entire system should be operated at lower sound pressure levels or the tweeters should be replaced by other models. Using the MULTICOM PRO in the corresponding tweeter band avoids overloading and thus damage to the speakers.

6.2.3 Improving The Sound Of A Processor System

A processor system is understood as a PA system which contains a special active crossover whose outputs are linked via separated power amplifiers to the loudspeakers. Each band has its own limiter whose task it is to limit dangerous signal peaks to a certain level. This process avoids overloading the subsequent power amplifier or destruction of the loudspeaker.

In some units, the crossover frequencies in the crossover unit are further changed during high signal levels to achieve a "loudness contour" suited to the human hearing. But in many cases, this function leads more to a disturbance than to an improvement of the sound quality.

If the MULTICOM PRO is preceding this system, the signal peaks can be eliminated before they reach the limiters of the processing system. The sound quality therefore remains natural and free of side effects caused by the changing frequencies of the crossover.

6.3 The MULTICOM PRO In Broadcast

The main aim of processing sound recordings for commercial radio and television is to achieve a maximum transmission volume at all costs. Owners of these radio and television stations strive to get bigger audience ratings, because principally, radio programs whose reception is louder than the average are preferred by the listener. By achieving a bigger audience, the broadcast station gains more money from the increasing number of promotion companies placing adverts.

What is volume?

Volume is defined as the relationship between the average level of program material to peak-to-peak level, in response to amplitude and duration. The higher the average level and the time it remains at a high level, the louder the program material will be perceived by the listener.

If you want to run your broadcast station at maximum average volume, proceed as mentioned in chapter 6.1.2 "The MULTICOM PRO In Mastering". Please make sure that the maximum peak level is below the threshold of the transmitter's limiter, otherwise this could lead to very hard and audible use of the transmission limiters. Keep in mind that a heavy increase in average volume by means of compression always leads to a loss in dynamics and an increased perception of side effects. The moderate use of the compressor and the Peak Limiter sections of the MULTICOM PRO result in higher average volumes, free of distortion.

7. SPECIFICATIONS

AUDIO INPUT

Connectors	XLR and 1/4" jack
Type	RF filtered, servo-balanced input
Impedance	50 kOhm balanced, 25 kOhm unbalanced
Nominal Operating Level	+4 dBu/-10 dBV switchable
Max. Input Level	+21 dBu balanced and unbalanced
CMRR	typ. 40 dB, >55 dB @ 1 kHz

AUDIO OUTPUT

Connectors	XLR and 1/4" jack
Type	Electronically servo-balanced output stage (optional transformer-balanced).
Impedance	60 Ohms balanced, 30 Ohm unbalanced
Max. Output Level	+21 dBu, +20 dBm balanced and unbalanced

SYSTEM SPECIFICATIONS

Bandwidth	20 Hz to 20 kHz, +0/-0.5 dB
Frequency Response	0.35 Hz to 200 kHz, +0/-3 dB
Noise	>-95 dBu, unweighted, 22 Hz to 22 kHz
THD	0.008 % typ. @ +4 dBu, 1 kHz, Gain 1 0.04 % typ. @ +20 dBu, 1 kHz, Gain 1
IMD	0.01 % typ. SMPTE
Crosstalk	<-100 dB, 22 Hz to 22 kHz
Stereo Coupling	True RMS detection

COMPRESSOR SECTION

Type	IKA (Interactive Knee Adaptation) Compressor
Threshold	variable (-40 dB to +20 dB)
Ratio	variable (1:1 to ∞:1)
Threshold characteristics	variable (Interactive or Hard Knee)
Auto characteristics	Wave Adaptive Compressor
Auto Attack Time	typ. 15 ms at 10 dB, 5 ms at 20 dB, 3 ms at 30 dB
Auto Release Time	program dependent, typ. 125 dB/s
Output	variable (-20 to +20 dB)

PEAK LIMITER SECTION

Type	IGC (Interactive Gain Control) Peak Limiter
Threshold	variable (+4 dB to OFF (+22 dBu))
Ratio	∞:1
Stage 1 Limiter Type	Clipper
Attack	"zero"
Release	"zero"
Stage 2 Limiter Type	Program Limiter
Attack	program dependent, typ. < 5 ms
Release	program dependent, typ. 20 dB/s

FUNCTION SWITCHES

INTERACTIVE	Enables the "Interactive Knee Adaptation" characteristics.
CONTOUR	Allows for frequency dependent detection.
I/O METER	Switches between input and output for the Level Meter.
IN/OUT	Bypass switch.
OPERATING LEVEL	Changes the internal reference level from +4 dBu to -10 dBV.
COUPLE	Linking channels 1&2 or 3&4 for stereo operation. Channel 1 (or 3) becomes master.

INDICATORS

GAIN REDUCTION	8 element LED display: 1/3/6/10/15/20/25/30 dB
INPUT/OUTPUT LEVEL	8 element LED display: -24/-18/-12/-6/0/+6/+12/+18 dB
Peak Limiter Threshold	1 LED for Indication of Limiter function
Function switch	LED indicator for each

POWER SUPPLY

Mains Voltages	USA/Canada	120 V ~, 60 Hz
	U.K./Australia	240 V ~, 50 Hz
	Europe	230 V ~, 50 Hz
	General Export Model	100 - 120 V ~, 200 - 240 V ~, 50 - 60 Hz
Fuse	100 - 120 V ~: T 630 mA H	
	200 - 240 V ~: T 315 mA H	
Power Consumption	max. 32 W	
Mains Connection	Standard IEC receptacle	

PHYSICAL

Dimension	1 3/4" (44.5 mm) * 19" (482.6 mm) * 8 1/2" (217 mm)
Net Weight	2.2 kg
Shipping Weight	3.4 kg

BEHRINGER is constantly striving to maintain the highest professional standards. As a result of these efforts, modifications may be made from time to time to existing products without prior notice. Specifications and appearance may differ from those listed or illustrated.

8. WARRANTY

§ 1 WARRANTY CARD/ONLINE REGISTRATION

To be protected by the extended warranty, the buyer must complete and return the enclosed warranty card within 14 days of the date of purchase to BEHRINGER Spezielle Studiotechnik GmbH, in accordance with the conditions stipulated in § 3. Failure to return the card in due time (date as per postmark) will void any extended warranty claims.

Based on the conditions herein, the buyer may also choose to use the online registration option via the Internet (www.behringer.com or www.behringer.de).

§ 2 WARRANTY

1. BEHRINGER (BEHRINGER Spezielle Studiotechnik GmbH including all BEHRINGER subsidiaries listed on the enclosed page, except BEHRINGER Japan) warrants the mechanical and electronic components of this product to be free of defects in material and workmanship for a period of one (1) year from the original date of purchase, in accordance with the warranty regulations described below. If the product shows any defects within the specified warranty period that are not due to normal wear and tear and/or improper handling by the user, BEHRINGER shall, at its sole discretion, either repair or replace the product.

2. If the warranty claim proves to be justified, the product will be returned to the user freight prepaid.

3. Warranty claims other than those indicated above are expressly excluded.

§ 3 RETURN AUTHORIZATION NUMBER

1. To obtain warranty service, the buyer (or his authorized dealer) must call BEHRINGER (see enclosed list) during normal business hours **BEFORE** returning the product. All inquiries must be accompanied by a description of the problem. BEHRINGER will then issue a return authorization number.

2. Subsequently, the product must be returned in its original shipping carton, together with the return authorization number to the address indicated by BEHRINGER.

3. Shipments without freight prepaid will not be accepted.

§ 4 WARRANTY REGULATIONS

1. Warranty services will be furnished only if the product is accompanied by a copy of the original retail dealer's invoice. Any product deemed eligible for repair or replacement by BEHRINGER under the terms of this warranty will be repaired or replaced within 30 days of receipt of the product at BEHRINGER.

2. If the product needs to be modified or adapted in order to comply with applicable technical or safety standards on a national or local level, in any country which is not the country for which the product was originally developed and manufactured, this modification/adaptation shall not be considered a defect in materials or workmanship. The warranty does not cover any such modification/adaptation, irrespective of whether it was carried out properly or not. Under the terms of this warranty, BEHRINGER shall not be held responsible for any cost resulting from such a modification/adaptation.

3. Free inspections and maintenance/repair work are expressly excluded from this warranty, in particular, if caused by improper handling of the product by the user.

This also applies to defects caused by normal wear and tear, in particular, of faders, potentiometers, keys/buttons and similar parts.

4. Damages/defects caused by the following conditions are not covered by this warranty:

- ▲ misuse, neglect or failure to operate the unit in compliance with the instructions given in BEHRINGER user or service manuals.
- ▲ connection or operation of the unit in any way that does not comply with the technical or safety regulations applicable in the country where the product is used.
- ▲ damages/defects caused by force majeure or any other condition that is beyond the control of BEHRINGER.

5. Any repair or opening of the unit carried out by unauthorized personnel (user included) will void the warranty.

6. If an inspection of the product by BEHRINGER shows that the defect in question is not covered by the warranty, the inspection costs are payable by the customer.

7. Products which do not meet the terms of this warranty will be repaired exclusively at the buyer's expense. BEHRINGER will inform the buyer of any such circumstance. If the buyer fails to submit a written repair order within 6 weeks after notification, BEHRINGER will return the unit C.O.D. with a separate invoice for freight and packing. Such costs will also be invoiced separately when the buyer has sent in a written repair order.

§ 5 WARRANTY TRANSFERABILITY

This warranty is extended exclusively to the original buyer (customer of retail dealer) and is not transferable to anyone who may subsequently purchase this product. No other person (retail dealer, etc.) shall be entitled to give any warranty promise on behalf of BEHRINGER.

§ 6 CLAIM FOR DAMAGES

Failure of BEHRINGER to provide proper warranty service shall not entitle the buyer to claim (consequential) damages. In no event shall the liability of BEHRINGER exceed the invoiced value of the product.

§ 7 OTHER WARRANTY RIGHTS AND NATIONAL LAW

1. This warranty does not exclude or limit the buyer's statutory rights provided by national law, in particular, any such rights against the seller that arise from a legally effective purchase contract.

2. The warranty regulations mentioned herein are applicable unless they constitute an infringement of national warranty law.

The information contained in this manual is subject to change without notice. No part of this manual may be reproduced or transmitted in any form or by any means, electronic or mechanical, including photocopying and recording of any kind, for any purpose, without the express written permission of BEHRINGER Spezielle Studiotechnik GmbH.

BEHRINGER and MULTICOM are registered trademarks.

ALL RIGHTS RESERVED. © 2001 BEHRINGER Spezielle Studiotechnik GmbH.

BEHRINGER Spezielle Studiotechnik GmbH, Hanns-Martin-Schleyer-Str. 36-38, 47877 Willich-Münchheide II, Germany

Tel. +49 (0) 21 54 / 92 06-0, Fax +49 (0) 21 54 / 92 06-30

Free Manuals Download Website

<http://myh66.com>

<http://usermanuals.us>

<http://www.somanuals.com>

<http://www.4manuals.cc>

<http://www.manual-lib.com>

<http://www.404manual.com>

<http://www.luxmanual.com>

<http://aubethermostatmanual.com>

Golf course search by state

<http://golfingnear.com>

Email search by domain

<http://emailbydomain.com>

Auto manuals search

<http://auto.somanuals.com>

TV manuals search

<http://tv.somanuals.com>