

BEKO

*installation, operation &
food storage instructions*

**GNE V320 S
GNE V320 B
GL32APB
GNE V320APS
GNE V321APX**



get the **best** from your new refrigerator

Please read this manual first!

Dear Customer,

We hope that your product, which has been produced in a 1st-class manufacturing facility and checked under the most meticulous quality control procedures, will provide you with years of good service.

For this, we recommend you to carefully read the entire manual of your product before using it and keep it at hand for future reference.

This manual

- Will help you use your appliance quickly and safely.
- Read the manual before installing and operating your product.
- Follow the instructions, especially those for safety.
- Keep the manual in an easily accessible place as you may need it later.
- Besides, read also the other documents provided with your product.

Please note that this manual may be valid for other models as well.

Symbols and their descriptions

This instruction manual contains the following symbols:

- ⓘ Important information or useful usage tips.
- ⚠ Warning against dangerous conditions for life and property.
- ⚡ Warning against electric voltage.



This product is supplied with the selective sorting symbol for waste electrical and electronic equipment (WEEE).

This means that this product must be handled pursuant to European Directive 2002/96/EC in order to be recycled or dismantled to minimise its impact on the environment. For further information, please contact your local or regional authorities.

Electronic products not included in the selective sorting process are potentially dangerous for the environment and human health due to the presence of hazardous substances.

1 Your Refrigerator 3

2 Warnings 4

ELECTRICAL REQUIREMENTS..... 5

WARNING! THIS APPLIANCE MUST BE

EARTHED..... 5

ENERGY SAVING TIPS 6

3 Installation 7

Points to be considered when re-
transporting your refrigerator 7

Before operating your refrigerator 7

Electric connection..... 7

Disposing of the packaging 8

Disposing of your old refrigerator..... 8

Placing and Installation..... 8

Floor balance adjustment 9

Adjusting the gap between the upper
door 11

Installing Water Filter 12

Connection of the Water Pipe to the
Refrigerator..... 13

Connection of Water Hose to the Jug 15

Connection of the Water Pipe to the Cold
Water Mains Line 15

Prior to first use of Ice/Water Dispenser17

4 Preparation 18

5 Using your refrigerator 19

Setting the fridge compartment
temperature 20

Setting the freezer compartment
temperature 20

Fresh Freeze Function 20

Quick Cool Function 21

Vacation Button 21

Auto Eco Button (Special Economy
function) 21

Key Lock Button 21

Water Dispenser Illumination 21

Water/Ice Type Selection 21

Ice/Water Dispenser..... 21

Using the Ice Dispenser 22

Ice Off..... 22

Using the water spring 23

Spillage Tray 23

Sliding Body Shelves..... 23

Blue light 24

Egg tray 24

Fresh Freeze Compartment 24

Crisper humidity control sliders..... 24

Recommendations for preservation of
frozen food 25

Defrosting 25

Replacing the Interior Light Bulb..... 25

6 Maintenance and cleaning27

Protection of plastic surfaces 27

Chill compartment..... 28

Icebox and Water Dispenser 28

**7 Recommended solutions for
the problems 29**

8 Guarantee Details 32

9 How To Obtain Service 33

1 Your Refrigerator

Congratulations on your choice of a BEKO quality Appliance which has been designed to give you service for many years.

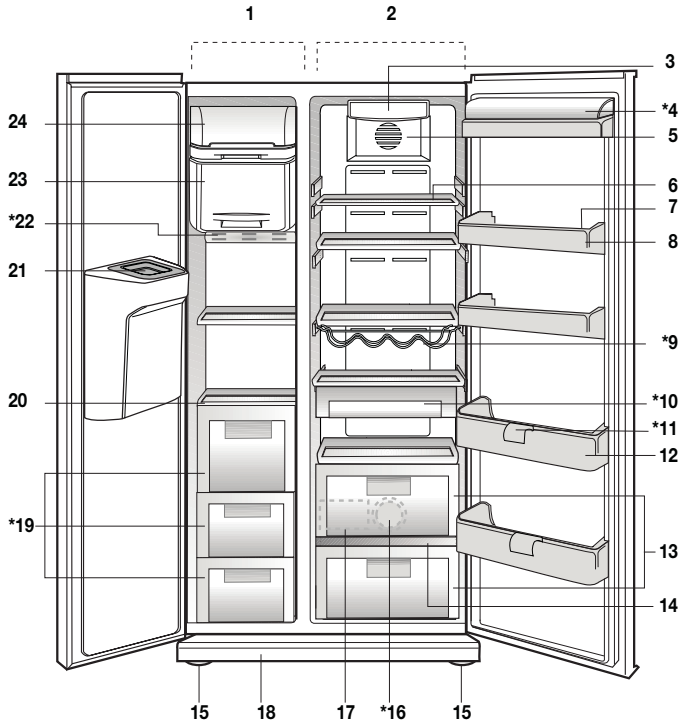

- | | |
|--------------------------------------|--|
| 1. Freezer compartment | 14. Crisper cover |
| 2. Fridge compartment | 15. Adjustable front legs |
| 3. Fridge compartment interior light | 16. Blue light |
| 4. Butter and cheese lid | 17. Water reservoir |
| 5. Fan | 18. Ventilation lid |
| 6. Fridge compartment glass shelves | 19. Freezer compartment drawers |
| 7. Egg tray | 20. Freezer Compartment glass shelves |
| 8. Fridge compartment door racks | 21. Ice duct lid |
| 9. Wine cellar | 22. Freezer compartment interior light |
| 10. Snack tray | 23. Fresh Freeze compartment |
| 11. Bottle holder | 24. Ice container |
| 12. Bottle shelves | * OPTIONAL |
| 13. Crisper compartments | |

1 Figures that take place in this instruction manual are schematic and may not correspond exactly with your product. If the subject parts are not included in the product you have purchased, then it is valid for other models.

2 Warnings

- DO NOT connect your appliance to the electricity supply until all packing and transit protectors have been removed.
- Leave to stand for at least 4 hours before switching on to allow compressor oil to settle if transported horizontally.
- If you are discarding an old refrigerator with a lock or latch fitted to the door, disable the lock/latch, ensure that it is left in a safe condition to prevent the entrapment of young children.
- This fridge/freezer must only be used for its intended purpose i.e the storing and freezing of edible foodstuff.
- Do not dispose of the appliance on a fire. At **BEKO**, the care and protection of our environment is an ongoing commitment. This appliance which is among the latest range introduced is particularly environment friendly. Your appliance contains non CFC / HFC natural substances in the cooling system (Called R600a) and in the insulation (Called cyclopentane) which are potentially flammable if exposed to fire. Therefore, take care not to damage, the cooling circuit / pipes of the appliance in transportation and in use. In case of damage do not expose the appliance to fire or potential ignition source and immediately ventilate the room where the appliance is situated.
- We suggest you contact your local authority for disposal information and facilities available.
- See Installation Instructions on page 8 for information on suitable location.
- To obtain the best possible performance and trouble free operation from your appliance it is very important to carefully read these instructions.
- On delivery, check to make sure that the product is not damaged and that all the parts and accessories are in perfect condition.
- Ensure that the plug remains readily accessible. Do not use multiple adapter bar or extension cable.
- Failure to observe these instructions may invalidate your right to free service during the guarantee period.
- Keep ventilation openings, in the appliance enclosure or in the built-in structure, clear of obstruction.
- Do not use mechanical devices or other means to accelerate the defrosting process, other than those recommended by the manufacturer.
- Do not damage the refrigerant circuit.
- Do not use electrical appliances inside the food storage compartments of the appliance, unless they are of the type recommended by the manufacturer.
- We suggest you keep these instructions in a safe place for easy reference.
- This appliance is not intended for use by persons (including children) with reduced physical, sensory or mental capabilities, or lack of experience and knowledge, unless they have been given supervision or instruction concerning use of the appliance by a person responsible for their safety.
- Children should be supervised to ensure that they do not play with the appliance.

ELECTRICAL REQUIREMENTS

Before you insert the plug into the wall socket make sure that the voltage and the frequency shown on the rating plate inside the appliance corresponds to your electricity supply.

Rating label is on the left hand side of fridge inner liner.

We recommend that this appliance be connected to the mains supply via a suitable switched and fused socket.

The appliance must be positioned so that the plug is accessible.

Should the mains lead of the appliance become damaged or should it need replacing at any time, it must be replaced by a special purpose made mains lead which can only be obtained from a BEKO Authorised Service Agent.

WARNING! THIS APPLIANCE MUST BE EARTHED

If the fitted moulded plug is not suitable for your socket, then the plug should be cut off and an appropriate plug fitted. Destroy the old plug which is cut off as a plug with bared cord could cause a shock hazard if inserted into a socket elsewhere in the house.

The moulded plug on this appliance incorporates a 13 A fuse. Should the fuse need to be replaced an ASTABEAB approved BS 1362 fuse of the same rating must be used. Do not forget to refit the fuse cover. In the event of losing the fuse cover the plug must not be used until a replacement fuse cover has been fitted. Colour of the replacement fuse cover must be the same colour as that visible on the pin face of the plug. Fuse covers are available from any good electrical store.

IMPORTANT! FITTING A DIFFERENT PLUG

As the colours of the wires in the mains lead of this appliance may not correspond with the coloured markings identifying the terminals in your plug proceed as follows: (See diagram).

1. Connect the green-yellow or green (Earth) wire to the terminal in the plug marked 'E' or with the symbol  or coloured green and yellow or green.
2. Connect the blue (Neutral) wire to the terminal in the plug marked 'N' or coloured black.
3. Connect the brown (Live) wire to the terminal in the plug marked 'L' or coloured red.

With alternative plugs a 13 A fuse must be fitted either in the plug or adaptor or in the main fuse box. If in doubt contact a qualified electrician.

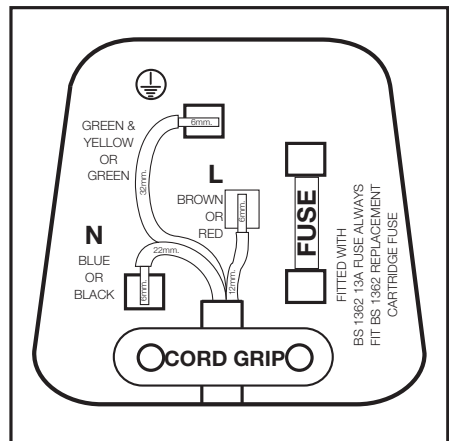

ENERGY SAVING TIPS

- 1- Ensure your appliance is installed in a well ventilated area.
- 2- Ensure the time between buying chilled/frozen food and placing them in your appliance is kept to a minimum, particularly in summer. We recommend you use a cool bag or a special carrier bag to carry frozen food.
- 3- Do not leave the door (s) of your appliance open longer than necessary and ensure they are closed properly after each opening.
- 4- Defrost frozen food in the fridge compartment, so that frozen food acts as an ice pack to assist cooling in the fridge.

3 Installation

i Please remember that the manufacturer shall not be held liable if the information given in the instruction manual is not observed.

Points to be considered when re-transporting your refrigerator

1. Your refrigerator must be emptied and cleaned prior to any transportation.
2. Shelves, accessories, crisper and etc. in your refrigerator must be fastened securely by adhesive tape against any jolt before repackaging.
3. Packaging must be tied with thick tapes and strong ropes and the rules of transportation printed on the package must be followed.

i Always remember...

Every recycled material is an indispensable source for the nature and for our national resources. If you wish to contribute to recycling the packaging materials, you can get further information from the environmental bodies or local authorities.

Before operating your refrigerator

Before starting to use your refrigerator check the following:

1. Is the interior of the refrigerator dry and can the air circulate freely in the rear of it?
2. Clean the interior of the refrigerator as recommended in the "Maintenance and cleaning" section.
3. Plug the refrigerator into the wall outlet. When the door is open the respective interior light will come on.
4. You will hear a noise as the compressor starts up. The liquid and gases sealed within the refrigeration system may also give rise to noise, even if the compressor is not running and this is quite normal.
5. Front edges of the refrigerator may feel warm. This is normal. These areas are designed to be warm to avoid condensation.

Electric connection

Connect your refrigerator to a grounded socket which is being protected by a fuse with the appropriate capacity.

Important:

- ⚠** The connection must be in compliance with national regulations.
- ⚠** The power cable plug must be easily accessible after installation.
- ⚠** Voltage and allowable fuse protection are specified in the "Technical Specifications" section.
- ⚠** The specified voltage must be equal to your mains voltage.
- ⚠** Extension cables and multiway plugs must not be used for connection.

- ⚠ A damaged power cable must be replaced by a qualified electrician.
- ⚠ The appliance must not be operated before it is repaired! There is danger of electric shock!

Disposing of the packaging

⚠ The packing materials may be dangerous for children. Keep the packing materials out of the reach of children or dispose them of by classifying them in accordance with the waste instructions. Do not dispose them of along with the normal household waste.

The packing of your refrigerator is produced from recyclable materials.

Disposing of your old refrigerator

Dispose of your old machine without giving any harm to the environment.

- ⚠ You may consult your authorized dealer or waste collection center of your municipality about the disposal of your refrigerator.
- ⚠ Before disposing of your refrigerator, cut out the electric plug and, if there are any locks on the door, make them inoperable in order to protect children against any danger.

Placing and Installation

⚠ Caution: Never plug the refrigerator into the wall outlet during installation. Otherwise, risk of death or serious injury may arise.

1. Install your refrigerator to a place that allows ease of use.
2. Keep your refrigerator away from heat sources, humid places and direct sunlight.
3. There must be appropriate air ventilation around your refrigerator in order to achieve an efficient operation. If the refrigerator is to be placed in a recess in the wall, there must be at least 5 cm distance with the ceiling and at least 5 cm with the wall. If the floor is covered with a carpet, your product must be elevated 2.5 cm from the floor.
4. Place your refrigerator on an even floor surface to prevent jolts.
5. Do not keep your refrigerator in ambient temperatures under 10°C.

Floor balance adjustment

If your refrigerator is unbalanced;
You can balance your refrigerator by turning the front legs of it as illustrated in the figure. (See Figure A) The corner where the leg exists is lowered when you turn in the direction of black arrow and raised when you turn in the opposite direction. Taking help from someone to slightly lift the refrigerator will facilitate this process.

Door height adjustment

In case there is a problem with the alignment of the doors with respect to each other, they may be aligned by ascension vertically in the order given below. Ensure that door shelves are empty when adjusting the door height.

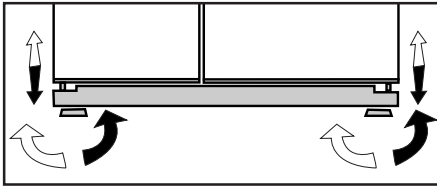

(A)

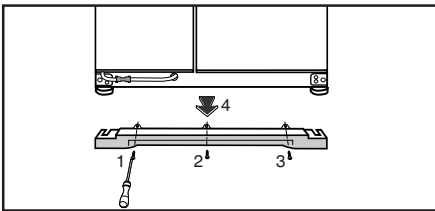

(B)

1. Remove the lower ventilation cover by unscrewing its screws as shown in the figure below. (See Figure B)

2. Loosen the three screws of the hinges of the lower door, which you wish to escalate, with the help of a screwdriver as shown in the figure below. (Do not remove completely) (See Figure C)

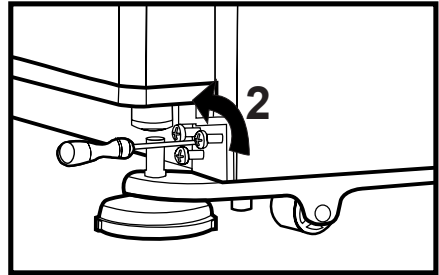

(C)

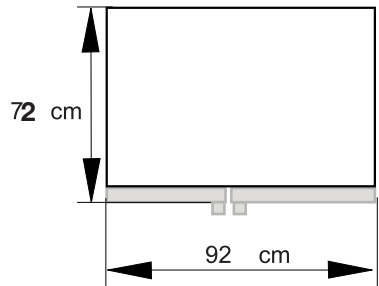
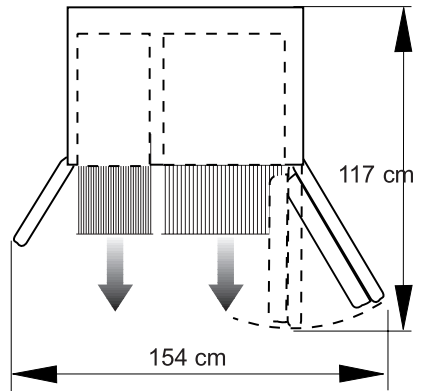

- If the freezer compartment door is lower than the fridge compartment door, bring them to the same level by turning the elevation screw on the freezer compartment side in the direction of arrow using a M6 Allen wrench as illustrated in Figure D.

- If the freezer compartment door is higher than the fridge compartment door, bring them to the same level by turning the elevation screw on the freezer compartment side in the direction of arrow using a M6 Allen wrench as illustrated in Figure D. After bringing the doors to the same level by elevating the front part with the aid of the elevation screws, doors of the refrigerator shall close properly. If the doors do not close properly, this might adversely affect the efficiency of the refrigerator.

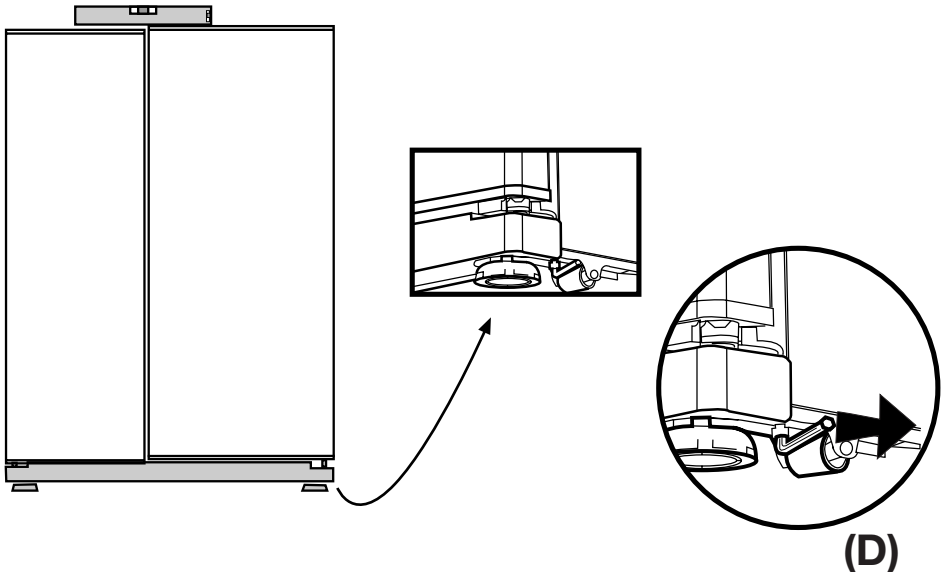

Adjusting the gap between the upper door

i You can adjust the gap between the fridge compartment doors as illustrated in the figures.

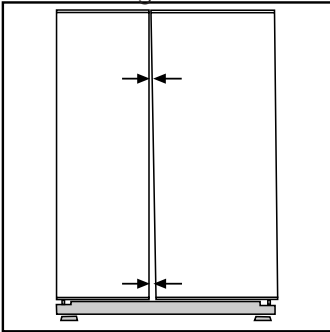

Door shelves should be empty when adjusting the door height.
Switch off the refrigerator power before removing hinge covers

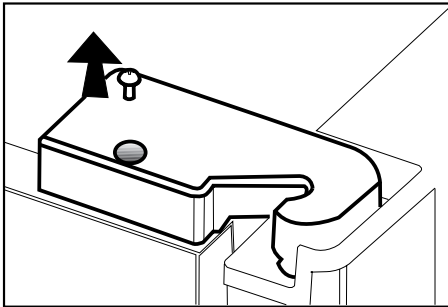

i Using a screwdriver, remove the screw of upper hinge cover of the door you want to adjust.

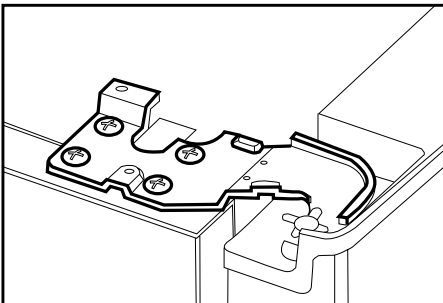

i Adjust the door appropriately as you desire by loosening the screws.

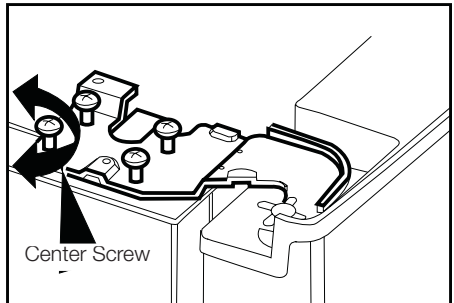
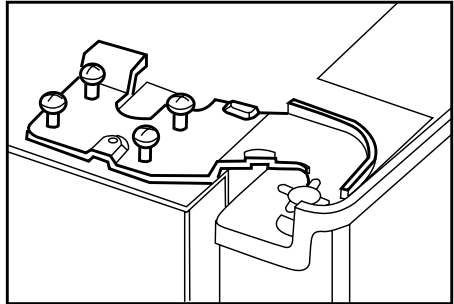

i Fix the door you have adjusted by tightening the screws without changing the position of the door.

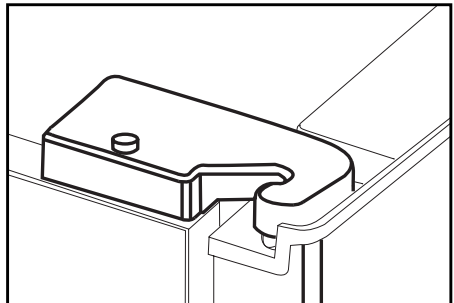

i Replace the hinge cover and fix with the screw.

Installing Water Filter

(In some models)

Installation Requirements

Two different water sources may be connected to the refrigerator for water supply: the mains cold water supply and water in a jug.

A pump should be used for jug water usage.

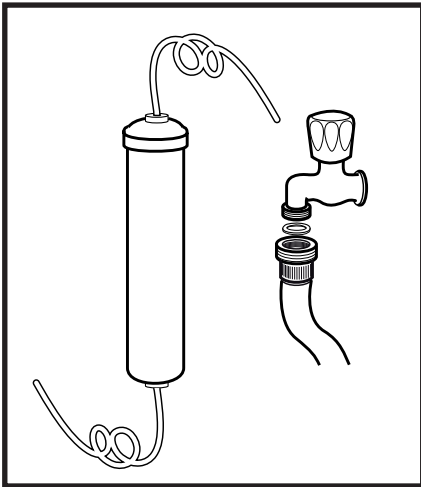

Check that the parts stated below are supplied with your appliance.

1. Union for connection of the water pipe to the rear of the appliance
2. 3 pieces of pipe clips (In case required to secure the water pipe)

i Note: Since the following parts are not required in use with a jug, they may not be found in the product you purchased.

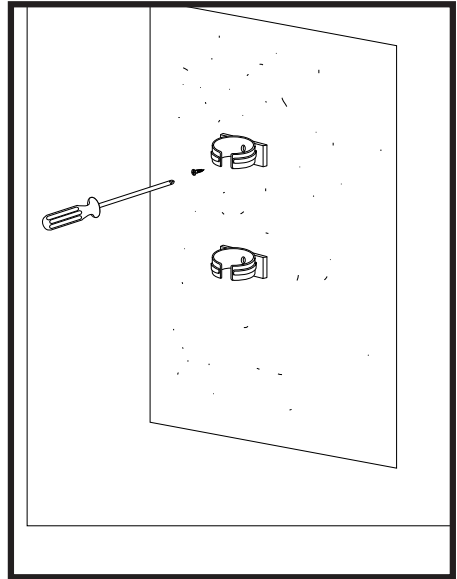

3. 5 meter long water pipe (1/4 inch in diameter)
4. Cold mains water valve with mesh filter (Tap Adapter)
5. Water Filter to be fitted to the bracket inside the fridge compartment.

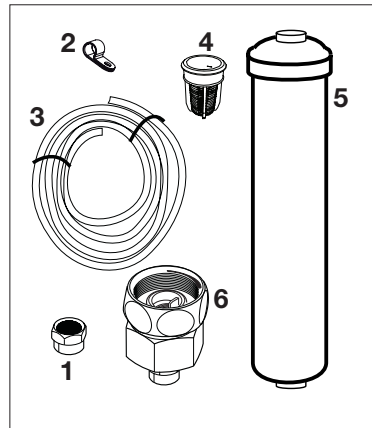

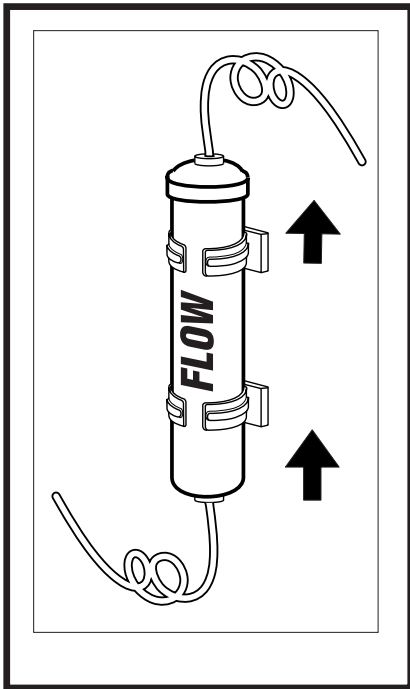

Water connection to the refrigerator
Please follow the instructions below.

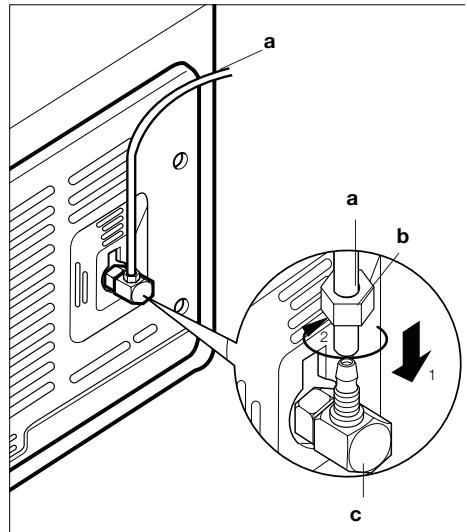

Connection of the Water Pipe to the Refrigerator

1. After installing the union onto the water pipe, insert the water pipe to the refrigerator inlet valve by pressing downwards firmly.
 2. Fix union as seen in the opposite figure, by squeezing by hand on the refrigerator inlet valve.
- (a- Water Pipe, b-Union, c-Valve)

ⓘ Note 1: You should not need to tighten the union with a tool to achieve water tight assembly. In case of a leak use a spanner or a pair of pliers to tighten the union.

To fit the water filter follow the instructions below referring to figures supplied:

1. Press ice cancel button on the display. (Figure 1)

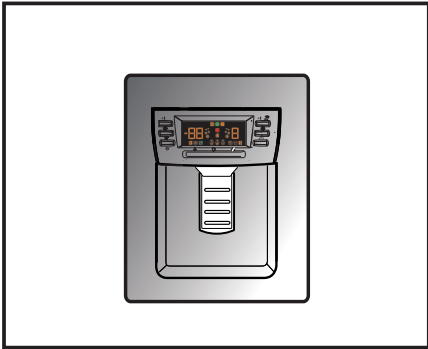

2. Remove the filter cover in the fridge compartment by pulling it forward. (Figure 2)
3. Take out the water filter by-pass cover by rotating it downwards. (Figure 3-4)

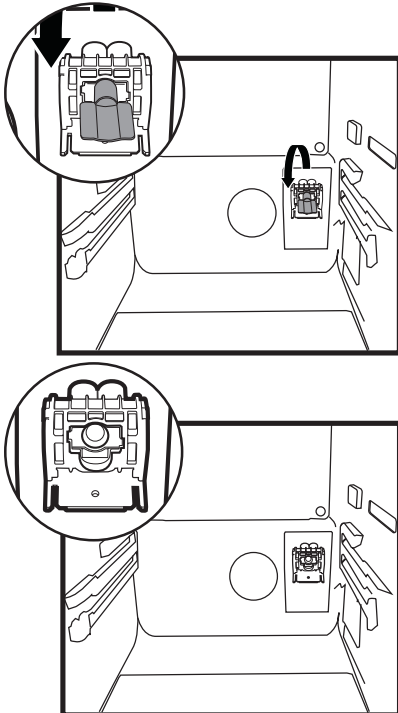

⚠ Warning: Make sure that the “Ice off” mode is active before taking out the by-pass cover.

Note: It is normal that a few drops of water drip after the cover has been taken out.

4. Remove the lid on top of the water filter to place it as shown in the figure and turn upwards to lock it. (Figure 5)
5. Press ice cancel button on the display again to exit from this mode.

Water filter should be replaced every 6 months. The water filter must be removed as shown in the figure when it is going to be replaced or when it will no longer be used and by-pass cover must be attached. It must be made sure that Ice Off mode is active before taking it out.

⚠ Warning: Water filter cleans some foreign particles in the water. It does not purify water from microorganisms.

⚠ Warning: Ice Off button must always be pressed during replacement of the water filter or installing the by-pass cover.

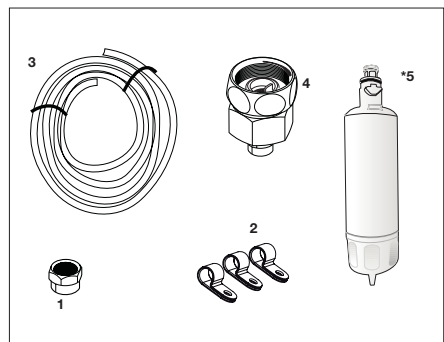

Connection of Water Hose to the Jug

(in some models)

To connect water to the refrigerator from a jug, a pump is needed. Follow the instructions below after connecting one end of the water pipe coming out of the pump to the refrigerator as described on the previous page.

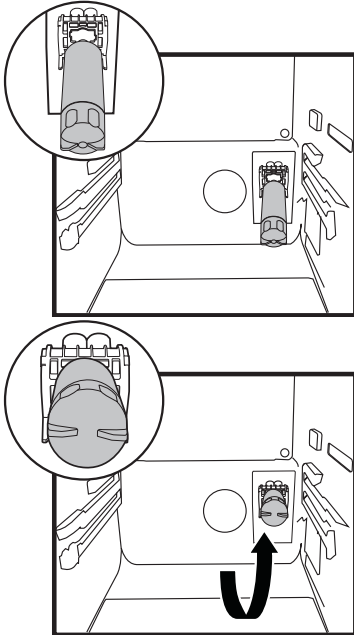

1. Finish the connection by pushing the other end of the water pipe into the water pipe inlet of the pump as shown in the figure.
2. Put and fix the pump hose into the jug as shown in the figure.
3. After completing the connection, plug in and run the pump.

To provide an efficient operation of the pump, wait for 2-3 minutes after starting the pump.

i Note: You may refer to the user manual of the pump while making the water connection.

Connection of the Water Pipe to the Cold Water Mains Line

(in some models)

If you want to use your refrigerator by connecting it to the cold water mains line,

you will have to connect a standard 1/2" valve connection fitting to the cold water supply in your house. In case this valve is not present or in case you are not sure, consult a qualified plumber.

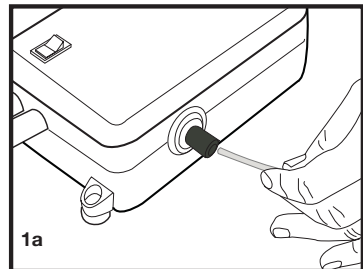

1a

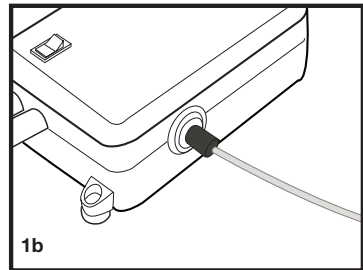

1b

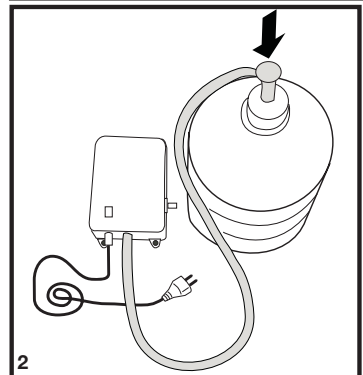

2

1. Separate the union from the tap adaptor. (Figure A)
2. Install the tap adaptor to 1/2" valve fitting as shown in the figure. (Figure B)
3. After inserting the water pipe to the union, install it to the tap adaptor and insert to the tap as shown in the figure. (Figure C)
4. Tighten the union manually. In case of a leak use a spanner or a pair of pliers to tighten the union.

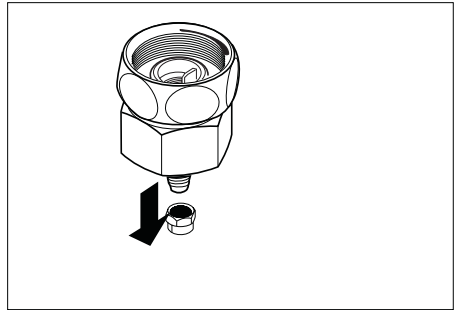

⚠ Warning: Secure the water pipe to suitable points by means of the pipe clips supplied to avoid any damage or displacement or accidental disconnection.

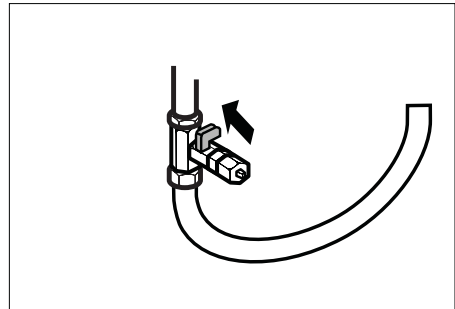

⚠ Warning: After turning on the water valve, make sure that there is no leakage at both connection points of the water pipe. In case of a leak, turn off the valve immediately and tighten all joints again using a spanner or a pair of pliers.

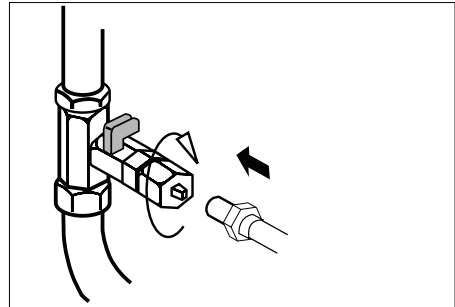

⚠ Warning: Make sure that standard 1/2" valve fitting fed by cold mains water supply is available and is turned off fully.

Note -1: There is no need to use water filter in case a jug is used.

Note -2: Pump must be used when jug will be used.

Prior to first use of Ice/Water Dispenser

i Water mains pressure must not be below 1 bar.

i Water mains pressure must not be over 8 bars.

i Pumps must be used in case the supply water pressure drops below 1 bar or if a jug is going to be used.

i Water system of the refrigerator must be connected to the cold water line. It must not be connected to hot water line.

i No water may be obtained in the initial startup of the refrigerator. This is caused by the air in the system. To discharge air from the system, press Dispenser latch for periods of 1 minute until water comes from the Dispenser. Water flow may be irregular in the beginning. Irregular water flow will be normalized after the air in the system is discharged.

i At the initial startup of the refrigerator approx. 12 hours must pass before cold water can be obtained.

i Water mains pressure must be between 1-8 bars for the operation of Ice/Water Dispenser smoothly. For this, check that 1 glass of water (100 cc) can be filled in 10 seconds.

i The first 10 glasses of water should not be consumed.

i 12 hours must pass to obtain ice from the Ice Dispenser for the first time. If there is not enough ice in the ice dispenser, ice may not be obtained from ice dispenser.

i Approximately the first 30 cubes of ice to be obtained from the Ice Dispenser must not be used.

i Always use the water filter when a jug is not being used.

4 Preparation

- i** Your refrigerator should be installed at least 30 cm away from heat sources such as hobs, ovens, central heater and stoves and at least 5 cm away from electrical ovens and should not be located under direct sunlight.
- i** The ambient temperature of the room where you install your refrigerator should at least be 10°C. Operating your refrigerator under cooler conditions than this is not recommended with regard to its efficiency.
- i** Please make sure that the interior of your refrigerator is cleaned thoroughly.
- i** If two refrigerators are to be installed side by side, there should be at least 2 cm distance between them.
- i** When you operate your refrigerator for the first time, please observe the following instructions during the initial six hours.
 - The door should not be opened frequently.
 - It must be operated empty without any food in it.
 - Do not unplug your refrigerator. If a power failure occurs out of your control, please see the warnings in the "Recommended solutions for the problems" section.
- i** Original packaging and foam materials should be kept for future transportations or moving.

5 Using your refrigerator

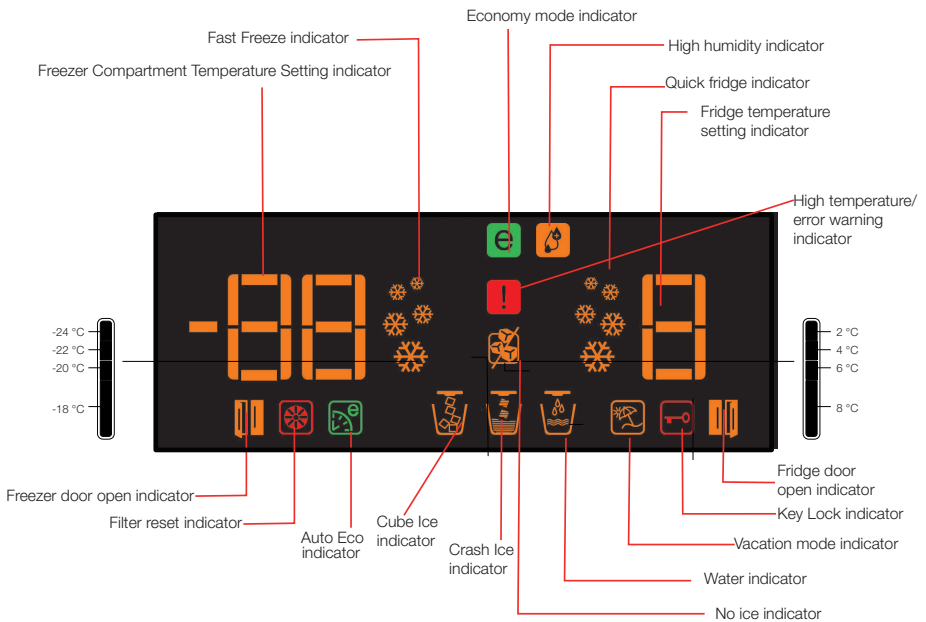
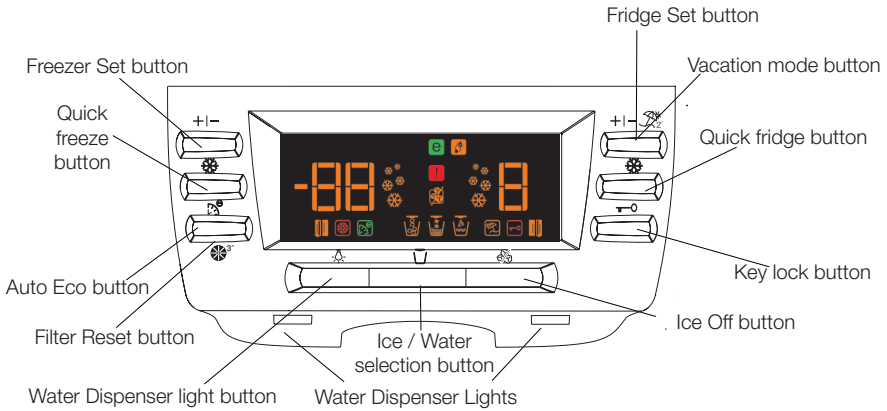

i Figures that take place in this instruction manual are schematic and may not correspond exactly with your product. If the subject parts are not included in the product you have purchased, then it is valid for other models.

Freezer Compartment Adjustment	Fridge Compartment Adjustment	Explanations
-18°C	4°C	This is the normal recommended setting.
-20,-22 or -24°C	4°C	These settings are recommended when the ambient temperature exceeds 30°C.
Fresh Freeze	4°C	Use this when you wish to freeze your food or make ice in a short time. Your refrigerator will return to its previous mode when the process is over.
-18°C or colder	2°C	If you think that your fridge compartment is not cold enough because of the hot conditions or frequent opening and closing of the door.
-18°C or colder	Quick Cool	You can use it when your fridge compartment is overloaded or if you wish to cool down your food rapidly.

Setting the fridge compartment temperature

Fridge compartment temperature can be set at one of the following temperatures:

8,6,4 and 2°C

Press the Fridge Set button to change.

The temperature will decrease by 2°C.

Every time you press the button, the temperature will go down and then return to the highest setting. Release at the desired temperature and the new set temperature will be stored.

If you think that your food is colder than you desire, you can adjust the temperature setting of fridge compartment to 6 or 8.

Setting the freezer compartment temperature

Freezer temperature can be set at one of the following temperatures : -18,-20,-22 and -24°C

Press the Freezer Set button to change. The temperature will decrease by 2°C. Every time you press the button, the temperature will go down and then return to the highest setting. Release at the desired temperature and the new set temperature will be stored.

Fresh Freeze Function

When you press “Fresh Freeze” button, the compressor will run for about 14 hours. Fresh Freeze indicator will glow.To cancel this function press Fresh Freeze button again. Fresh Freeze indicator will turn off and return to its normal settings. Fresh Freeze will cancel itself automatically after about 14 hours if you do not cancel it.

If you want to freeze large amounts of fresh food, press the Fresh Freeze button 14 hours before putting the food into the freezer compartment.

Quick Qool Function

When you press Quick Qool button, the temperature of the compartment will be colder than the adjusted values. This function can be used for food placed in the fridge compartment and required to be cooled down rapidly. After pressing the Quick Qool button, Quick Qool indicator will glow. To cancel this function press Quick Qool button again. Quick Qool indicator will turn off and return to its normal settings. Quick Qool function will cancel itself automatically in case you do not cancel it.

Vacation Button

In case the fridge compartment will not be used for a long time, the usage of the fridge compartment may be cancelled by pressing on the Vacation Button. By this way, the refrigerator may operate more economically. Press on Vacation Button for 3 seconds to activate this function. When this function is active, the door of the fridge compartment must be kept closed and no food must be left in the fridge compartment.

Auto Eco Button (Special Economy function)

When "Auto Eco" button is pressed, Auto Economy Function will be activated. If the door of the fridge compartment is kept closed for a long time when this function is selected, the fridge compartment will switch to a more economic operation mode to save electricity automatically. When the Auto Eco button is pressed again, this function is deactivated.

Key Lock Button

The key lock is activated when this button is pressed for 3 seconds and all buttons and the dispenser latch will not work. If you want to deactivate key lock press again for 3 seconds.

Water Dispenser Illumination

When the Light button is pressed, the water dispenser lamp will light up and it will go off when the button is pressed again. This illumination will also light up when the water dispenser latch is pressed, and it will go off delayed when the latch is released.

Water/Ice Type Selection

With Dispenser Selection button, either one of "water", "ice cube" or "crushed ice" options is selected.

Ice/Water Dispenser

With its three different functions, the dispenser efficiently meets your cold water, cube ice and crushed ice needs without having to open the door of the refrigerator. It is a continuous cold water and ice source without adding water. User friendly control panel provides the following dispensing functions:

Note:

- Water or ice can be dispensed for a maximum of 90 seconds at each use.
- When the freezer door is open, the dispenser will not work.

Ice Cube
Water



Crushed Ice



Cold
Water



Using the Ice Dispenser

i Please note, first ice cubes will not be ready before 12 hours after switching on the appliance.

In case you do not need ice, such as during winter or in case you are on vacation, select the ice off function.

i Ice device produces approximately 110 cubes of ice in 24 hours and this amount may change according to the frequency of opening of doors, refrigerator settings and power outage. Produced ice may be obtained from the dispenser as cube ice or crushed ice.

It is normal to get crushed ice from the dispenser in a longer time than in getting the ice cubes and also flowing of some crushed ice before the ice cubes drop if crushed ice option had been selected before selecting ice cube option.

i If the ice dispenser hasn't been used for a long time or after a power cut the ice may form clumps or if the ice has taken on a change in smell or taste then the ice must be disposed of and the icebox cleaned thoroughly.

Warnings

i No ice must be added to the ice dispenser compartment. This may adversely affect the ice supply or crushing the ice.

⚠ It is normal to have a couple of ice cubes stuck together in the icebank.

⚠ Moving parts such as blades in a housing at the ice outlet of the dispenser must not be touched to avoid injury.

⚠ Never use sharp objects to break the ice in the icebox. This may cause damage on the icebox.

⚠ Food stuff should never be placed into the icebox for quick cooling purposes.

⚠ When the icebox is to be removed for any reason, first of all Ice Off Button must be pressed.

Ice Off

i To stop ice formation, Ice Off button is pressed. When Ice Off is selected, no water will be taken into the Icematic. However, already existing ice can be taken from the dispenser. To restart ice formation, Ice Off button must be pressed again.

Warning: If you do not use the ice dispenser, do not forget to put ice duct cover into the ring inside of the freezer door. **(See. Your Refrigerator section)**

Using the water spring

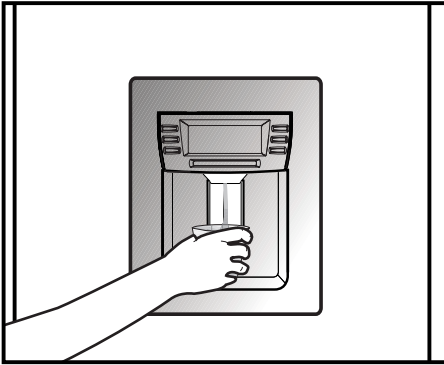

Warnings

It is normal for the first few glasses of water taken from the dispenser to be warm.

In cases where the water dispenser has not been used frequently, sufficient amount of water must be drained from the dispenser to get fresh water.

Spillage Tray

Water drops that drip during use, accumulates in the spillage tray. You can remove spillage tray by pulling it to yourself or pressing on its edge (depending on the model). You can remove the water with a sponge or a soft cloth.



Maximum height of glass suitable for use with Stored Water Dispenser is 16 cm which includes most of the "Standard" pint glasses.

Sliding Body Shelves

Sliding body shelves can be pulled by slightly lifting up from the front and moved back and forth. They come to a stop point when pulled towards front to allow you reach the foods placed at the back of the shelf; when it is pulled after slightly lifted upwards at the second stop point, the body shelf will be released.

The shelf should be hold tightly from the bottom as well in order to prevent it from tipping over. The body shelf is placed on the rails at the sides of the refrigerator body by bringing it to one lower or one upper level.

The body shelf should be pushed backwards to seat it completely.

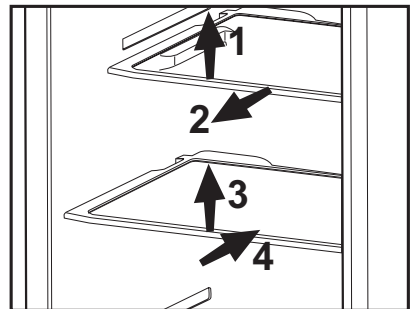

Blue light

Foodstuff stored in the crispers that are enlightened with a blue light continue their photosynthesis by means of the wavelength effect of blue light and thus, preserve their freshness and increase their vitamin content.

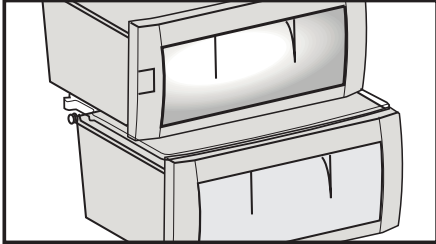

Egg tray

You can install the egg holder to the desired door or body shelf.

Never store the egg holder in the freezer compartment

Fresh Freeze Compartment

This compartment freezes your food quickly and preserves their tastes and nutritional values.

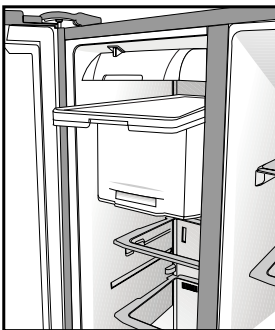

Crisper humidity control sliders

Crisper of your refrigerator is designed especially fresh to keep your vegetables freshly without losing their humidity. Cold air circulates basically around the crisper and the amount of the cold air passing through the crisper is controlled by the sliders on the front side of the crisper cover.

You can adjust the humidity control sliders to a suitable position according to the humidity and cooling condition of your food in the crisper.

If you want your food in the crisper to cool more, open the holes of the humidity control sliders and if you want them to cool less and keep their humidity for a longer time, close the holes.

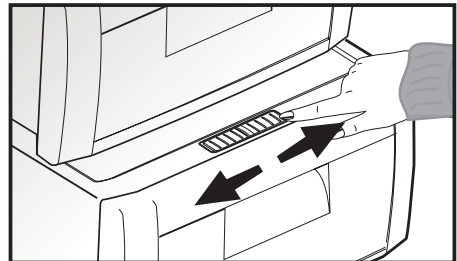

Recommendations for preservation of frozen food

- Prepacked commercially frozen food should be stored in accordance with the frozen food manufacturer's instructions for a *** ** *** (4 star) frozen food storage compartment.

- To ensure that the high quality achieved by the frozen food manufacturer and the food retailer is maintained, the following should be remembered:

1. Put packets in the freezer as quickly as possible after purchase.

2. Ensure that contents are labelled and dated.

3. Do not exceed "Use By", "Best Before" dates on the packaging.

If there is a power failure do not open the freezer door. Even if the power failure lasts up to the time specified on Type Label (inside left of the refrigerator), frozen food will not be affected. In case the failure lasts longer, the food must be checked and when necessary, must be consumed immediately or must be frozen after cooked.

Defrosting

The fridge and freezer compartments defrost automatically.

Replacing the Interior Light Bulb

Should the light fail to work, proceed as follows:

1. Switch off at the socket outlet and pull out the mains plug.

Remove all shelves and drawers for easy access.

2. Illumination cover in fridge section is opened by pressing by hand; first release one side and then the other by pressing on the sides as shown in the figures.

3. First check that the bulb has not worked loose by ensuring that it is screwed securely in the holder. Reinsert the plug and switch on. If the bulb works, reinstall the light cover by inserting the rear lug and pushing up to locate the front two lugs.

4. If the light still fails to work, switch off at the socket outlet and pull out the mains plug. Replace the bulb with a new 15 watt (max) screw cap E14 (SES) bulb.

5. Carefully dispose of the burnt-out light bulb immediately.

Replacement light bulb can easily be obtained from a good local electrical or DIY store.

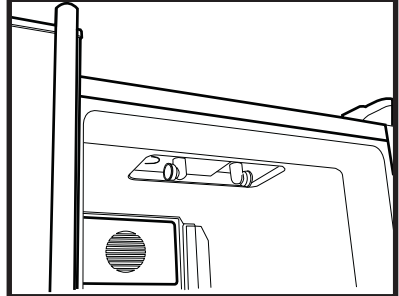
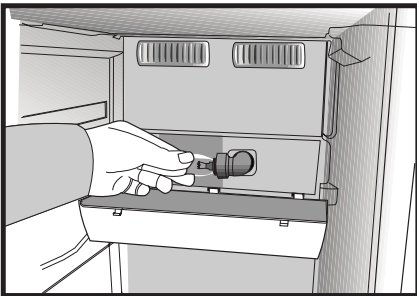
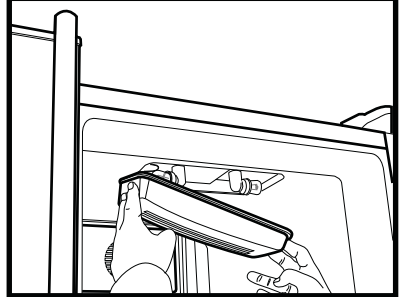
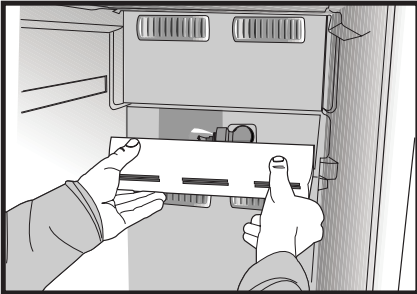
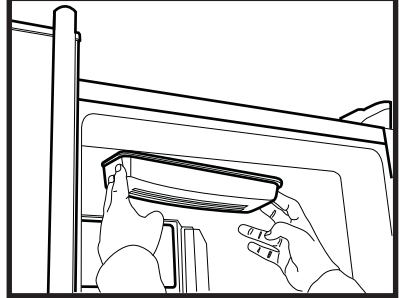
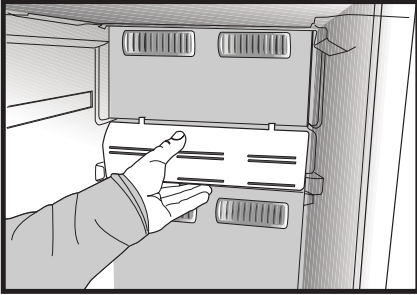
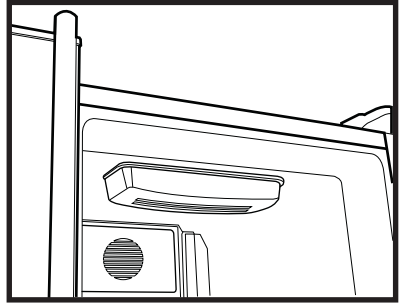
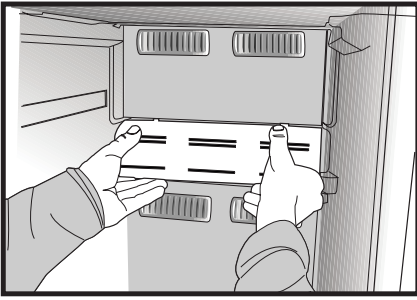

6 Maintenance and cleaning

- ⚠ Never use gasoline, benzene or similar substances for cleaning purposes.
- ⚠ We recommend that you unplug the appliance before cleaning.
- ⚠ Never use any sharp abrasive instrument, soap, household cleaner, detergent and wax polish for cleaning.
- ℹ Use lukewarm water to clean the cabinet of your refrigerator and wipe it dry.
- ℹ Use a damp cloth wrung out in a solution of one teaspoon of bicarbonate of soda to one pint of water to clean the interior and wipe it dry.
- ⚠ Make sure that no water enters the lamp housing and other electrical items.
- ⚠ If your refrigerator is not going to be used for a long period of time, unplug the power cable, remove all food, clean it and leave the door ajar.
- ℹ Check door seals regularly to ensure they are clean and free from food particles.
- ⚠ To remove door racks, remove all the contents and then simply push the door rack upwards from the base.

Protection of plastic surfaces

- ℹ Do not put the liquid oils or oil-cooked meals in your refrigerator in unsealed containers as they damage the plastic surfaces of your refrigerator. In case of spilling or smearing oil on the plastic surfaces, clean and rinse the relevant part of the surface at once with warm water.

Chill compartment

You can increase the inner volume of your refrigerator by removing the desired chill compartment. Pull the compartment towards yourself until it is stopped by the stopper. Raise the front part for approximately 1 cm and pull the compartment towards yourself again to remove it completely.

This compartment intended specifically for the storage of highly perishable foodstuffs. You can also use these compartments if you want to store your food at a temperature a few degrees below the fridge compartment.

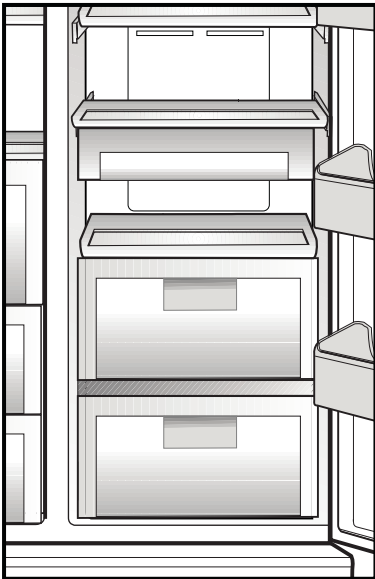

Icebox and Water Dispenser

i Follow the procedure and warnings below to clean the icebox:

- ⚠** Remove the Icebox by lifting first and then pulling towards yourself as shown in the diagram.
- ⚠** Empty the ice in the Icebox if any. To take out the stuck ice, use objects that are not sharp to avoid any damage on the Icebox.
- ⚠** Pay attention that the inside of the Icebox is not wet/damp before placing it back to its housing.
- ⚠** If you want to get ice from the ice dispenser after placing the Icebox back to its housing and closing the freezer door, exit from Ice Off mode by pressing the Ice Off key again.

⚠ Do not touch moving parts like the knife in the Icebox.

i Leave the Water Reservoir empty when you are not going to use for a long time

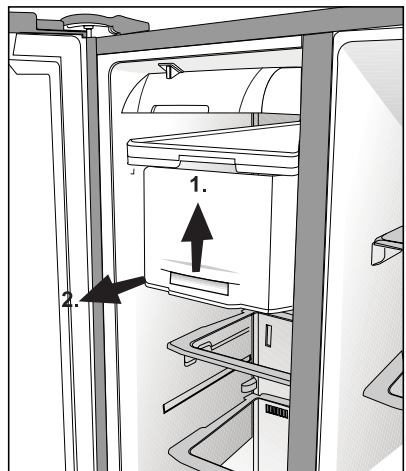

7 Recommended solutions for the problems

Please review this list before calling the service. It might save you time and money. This list includes frequent complaints that are not arising from defective workmanship or material usage. Some of the features described here may not exist in your product.

The refrigerator does not operate.

- Is the refrigerator properly plugged in? Insert the plug to the wall socket.
- Is the fuse of the socket which your refrigerator is connected to or the main fuse blown out? Check the fuse.

Condensation on the side wall of the fridge compartment (MULTIZONE, COOL CONTROL and FLEXI ZONE).

- Very cold ambient conditions. Frequent opening and closing of the door. Highly humid ambient conditions. Storage of food containing liquid in open containers. Leaving the door ajar. Switching the thermostat to a colder degree.
- Decreasing the time the door left open or using it less frequently.
- Covering the food stored in open containers with a suitable material.
- Wipe the condensation using a dry cloth and check if it persists.

Compressor is not running

- Protective thermic of the compressor will blow out during sudden power failures or plug-out plug-ins as the refrigerant pressure in the cooling system of the refrigerator has not been balanced yet. Your refrigerator will start running approximately after 6 minutes. Please call the service if the refrigerator does not startup at the end of this period.
- The fridge is in defrost cycle. This is normal for a full-automatically defrosting refrigerator. Defrosting cycle occurs periodically.
- Your refrigerator is not plugged into the socket. Make sure that the plug is properly fit into the socket.
- Are the temperature adjustments correctly made?
- Power might be cut off.

The fridge is running frequently or for a long time.

- Your new product may be wider than the previous one. This is quite normal. Large refrigerators operate for a longer period of time.
- The ambient room temperature may be high. This is quite normal.
- The refrigerator might have been plugged in recently or might have been loaded with food. Cooling down of the refrigerator completely may last for a couple of hours longer.
- Large amounts of hot food might have been put in the refrigerator recently. Hot food causes longer running of the refrigerator until they reach the safe storage temperature.
- Doors might have been opened frequently or left ajar for a long time. The warm air that has entered into the refrigerator causes the refrigerator to run for longer periods. Open the doors less frequently.
- Freezer or fridge compartment door might have been left ajar. Check if the doors are tightly closed.
- The refrigerator is adjusted to a very low temperature. Adjust the refrigerator temperature to a warmer degree and wait until the temperature is achieved.
- Door seal of the fridge or freezer may be soiled, worn out, broken or not properly seated. Clean or replace the seal. Damaged/broken seal causes the refrigerator to run for a longer period of time in order to maintain the current temperature.

Freezer temperature is very low while the fridge temperature is sufficient.

- The freezer temperature is adjusted to a very low temperature. Adjust the freezer temperature to a warmer degree and check.

Fridge temperature is very low while the freezer temperature is sufficient.

- The fridge temperature might have been adjusted to a very low temperature. Adjust the fridge temperature to a warmer degree and check.

Food kept in the fridge compartment drawers are freezing.

- The fridge temperature might have been adjusted to a very low temperature. Adjust the fridge temperature to a warmer degree and check.

Temperature in the fridge or freezer is very high.

- The fridge temperature might have been adjusted to a very high degree. Fridge adjustment has an effect on the temperature of the freezer. Change the temperature of the fridge or freezer until the fridge or freezer temperature reaches to a sufficient level.
- Doors might have been opened frequently or left ajar for a long time; open them less frequently.
- Door might have been left ajar; close the door completely.
- Large amount of hot food might have been put in the refrigerator recently. Wait until the fridge or freezer reaches the desired temperature.
- The refrigerator might have been plugged in recently. Cooling down of the refrigerator completely takes time.

The operation noise increases when the refrigerator is running.

- The operating performance of the refrigerator may change due to the changes in the ambient temperature. It is normal and not a fault.

Vibrations or noise.
<ul style="list-style-type: none"> • The floor is not even or it is weak. The refrigerator rocks when moved slowly. Make sure that the floor is strong enough to carry the refrigerator, and level. • The noise may be caused by the items put onto the refrigerator. Items on top of the refrigerator should be removed.
There are noises coming from the refrigerator like liquid spilling or spraying.
<ul style="list-style-type: none"> • Liquid and gas flows happen in accordance with the operating principles of your refrigerator. It is normal and not a fault.
There is a noise like wind blowing.
<ul style="list-style-type: none"> • Fans are used in order to cool the refrigerator. It is normal and not a fault.
Condensation on the inner walls of refrigerator.
<ul style="list-style-type: none"> • Hot and humid weather increases icing and condensation. It is normal and not a fault. • Doors might have been left ajar; make sure that the doors are closed fully. • Doors might have been opened frequently or left ajar for a long time; open them less frequently.
Humidity occurs on the outside of the refrigerator or between the doors.
<ul style="list-style-type: none"> • There might be humidity in the air; this is quite normal in humid weather. When the humidity is less, condensation will disappear.
Bad odour inside the refrigerator.
<ul style="list-style-type: none"> • Inside of the refrigerator must be cleaned. Clean the inside of the refrigerator with a sponge, lukewarm water or carbonated water. • Some containers or package materials might cause the smell. Use a different container or different brand packaging material.
The door is not closing.
<ul style="list-style-type: none"> • Food packages may prevent the door's closing. Replace the packages that are obstructing the door. • The refrigerator is not completely upright on the floor and rocking when slightly moved. Adjust the elevation screws. • The floor is not level or strong. Make sure that the floor is level and capable to carry the refrigerator.
Crispers are stuck.
<ul style="list-style-type: none"> • The food might be touching the ceiling of the drawer. Rearrange food in the drawer.

8 Guarantee Details

GUARANTEE DETAILS

Your new Beko product is guaranteed against the cost of breakdown repair for twelve months from the date of the original purchase.

What is covered?

- Repairs necessary as a result of faulty materials, defective components or manufacturing defect.
- The cost of functional replacement parts, but excluding consumable items.
- The labour costs of a Beko approved repairer to carry out the repair.

What is not covered?

- Transit, delivery or accidental damage or misuse and abuse.
- Cabinet or appearance parts, including control knobs, flaps, handles or container lids.
- Accessories or consumable items including but not limited to, ice trays, scrapers, cutlery baskets, filters and light bulbs.
- Repairs required as a result of unauthorised repair or inexperienced installation that fails to meet the requirements contained in the user instruction book.
- Repairs to products used on commercial or non-residential household premises.
- Loss of frozen food in freezers or fridge/freezers. (Food loss insurance is often included within your household contents insurance policy, or may be available separately from your retailer).

Important notes.

- Your Beko product is designed and built for domestic household use only.
- The guarantee will be void if the product is installed or used in commercial or non-residential domestic household premises.
- The product must be correctly installed, located and operated in accordance with the instructions contained in the User Instructions Booklet provided.
- Professional installation by a qualified Electrical Domestic Appliance Installer is recommended for all Washing Machines, Dishwashers and Electric Cookers
- Gas Cookers must only be installed by a Gas Safe (or BORD GAIS) registered Gas Installer.
- The guarantee is given only within the boundaries of the United Kingdom and the Republic of Ireland.
- The guarantee is applicable only to new products and is not transferable if the product is resold.
- Beko disclaims any liability for incidental or consequential damages.
The guarantee does not in anyway diminish your statutory or legal rights.

9 How To Obtain Service

HOW TO OBTAIN SERVICE

Please keep your purchase receipt or other proof of purchase in a safe place; you will need to have it should the product require attention under guarantee.

You should also complete the details below; it will help us assist you when requesting service. (The model number is printed on the Instruction Booklet and the serial number is printed on the Rating Label affixed to the appliance)

Model No: Serial No: Retailer: Date of purchase:

For service under guarantee simply telephone the appropriate number below

UK Mainland & Northern Ireland

Fridges & Freezers	0845 6004903
Electric Cookers	0845 6004902
Gas & Dual Fuel Cookers	0845 6004905
Washing Machines & Dishwashers	0845 6004906

Republic of Ireland

All Refrigeration, All Cookers Washing Machines & Dishwashers	01 862 3411
--	-------------

Before requesting service please check the trouble-shooting guide in the Operating Instructions as a charge may be levied where no fault is found even though your product may still be under guarantee.

Service once the manufacturers guarantee has expired.

If you have purchased an extended guarantee please refer to the instructions contained within the extended guarantee agreement document. Otherwise please call the appropriate number above where service can be obtained at a charge.

Should you experience any difficulty in obtaining service please contact the Beko Customer Help-Line. Tel: 0845 6004911 e-mail: service@beko.co.uk

BEKO



BEKO plc
Beko House
Caxton Way
Watford
Hertfordshire
WD18 8UF
Tel: 0845 6004911
Fax: 0845 6004922
e-mail: service@beko.co.uk
website: www.beko.co.uk

Printed in Turkey

Part no: 48 8558 0000
Revision no: A1

Free Manuals Download Website

<http://myh66.com>

<http://usermanuals.us>

<http://www.somanuals.com>

<http://www.4manuals.cc>

<http://www.manual-lib.com>

<http://www.404manual.com>

<http://www.luxmanual.com>

<http://aubethermostatmanual.com>

Golf course search by state

<http://golfingnear.com>

Email search by domain

<http://emailbydomain.com>

Auto manuals search

<http://auto.somanuals.com>

TV manuals search

<http://tv.somanuals.com>