



**IMPORTANT  
INFORMATION**  
For  
**CFG/CRG  
KF/KR SERIES**

**This cooler has passed the  
QUALITY CONTROL INSPECTION  
and meets the high standards  
at Beverage-Air.**

**This inspection includes  
complete refrigeration system,  
cabinet construction & finish.**



# BEVERAGE-AIR

## INSTALLATION AND OPERATING INSTRUCTIONS

### MODEL: CFG/CRG

### KF/KR SERIES

#### 1. **INSTALLATION:**

- a. **Receiving Inspection:**  
Upon receipt, check all packages for accessories or optional components, including legs, casters and shelves.
- b. **Leveling: CFG/CRG**  
To provide adequate condensate drainage, proper door alignment and operation, it is necessary that the cabinet be level. Screw type levelers are provided in each corner of the cabinet base. Level cabinet from front to rear and from side to side. This should be done after cabinet has been set in its final operating position.  
KF/FR: Have stem casters which must be installed, packed inside cabinet. Casters must be tight to cabinet base. If casters are not tight to the cabinet base, they may bend or break and possibly allow the cabinet to tip over.
- c. **Shelves:**  
Included are coated wire shelves packed inside cabinet. Shelf spacing is adjustable with enclosed shelf supports to suit requirements. Shelves can be tipped down at front for display by lowering front shelf support. Place bottom shelf up two inches to allow air to circulate under shelf.
- d. **Locating Cooler:**  
Provide at least three inches of space between cabinet and any adjacent wall or fixture at rear of cabinet.
- e. **Compressor Mounts (Most Freezers)**  
The compressor is mounted on four springs. For shipping these are compressed by a steel band around the compressor. White staying clear of uncoiling steel band, cut and remove the steel band.

#### 2. **OPERATION:**

- a. **Electrical Supply and Connections:**  
A wiring diagram is affixed to the left hand compressor housing in a plastic bag. It is important that the cabinet be wired into a separate single outlet circuit. Before connecting cabinet, check line voltage to assure it is compatible with the voltage specified on the data plate. Low line voltage is often the cause of service complaints. Wiring should be sufficient to carry the electrical load and to meet local codes. A qualified electrician should make the necessary electrical connections. Be sure cabinet is properly grounded.
- b. **Initial Start-Up:**  
Turn Power on and check that compressor and condenser fan are running. On CFG Models, evaporator fans are delayed in starting until the evaporator temperature has reached approx. 25°F (-4C) Once fans are running, a switch above each door will stop fans when the door is opened.
- c. **Interior Lights:**  
KF/KR: Models Light(s) are actuated by door switch(s).  
CFG/CRG: Models Light(s) are actuated by manual operated rocker switch(s). On freezer models with fluorescent lamps, the lamps will be off on initial start-up and during defrost when cabinet is above 25°F (-4C).  
  
Note: If unit is equipped with fluorescent lamps, replace with same size and wattage lamp. Do Not use reduced Wattage lamps. The reduced wattage lamps generally fail to light below 60°F (16C) and will damage the ballast.
- d. **Defrost System and Condensate Disposal:**  
The defrost timer and lamp ballast are located in the pull out drawer behind the grille. For access to these components, remove the bottom grille. Freezers are provided with electric defrost heater actuated by the defrost timer. The defrost timer clock provides for one to four defrost cycles per 24 hour period. The timer is factory set for four defrost cycles per 24 hour period to occur at 12 midnight, 6a.m., 12 noon and 6 p.m. When the freezer is placed in service the clock must be set to the time of day. The defrost cycle is normally temperature-terminated by an internal control switch. However, the defrost on-time is limited to 30 minutes by a separate setting. To set back up defrost termination, push down and rotate pointer on inside (2 hour) dial until it is opposite desired time. Refrigerators do not have a defrost timer. However, defrosting automatically with each cycle of the compressor. All cabinets are equipped with hot has condensate disposal system Outside drain hook up is unnecessary.
- e. **Temperature Control**  
The temperature control is factory set to maintain approximately the following air temperatures:  
KR "Control Setting" #4 =38°F (3°C)  
CRG "Control Setting" #4 =38°F (3°C)  
KF "Control Setting" #5 =0°F (-18°C)  
CFG "Control Setting" #3=-12°F (-25°C)  
  
For colder cabinet temperatures, turn knob clockwise, one number at a time, allowing one hour for temperature to stabilize. Excessive tampering with the control could lead to service difficulties. For operation above 3,000 ft. altitude, have temperature control calibrated by a qualified service technician.

#### 3. **MAINTENANCE**

- a. **Cleaning Cabinet Exterior:**  
Cabinet should be cleaned with a solution of mild soap and water. Do not use caustic soap and water. Do not use caustic soap or abrasive cleaners, since these might damage the cabinet finish. If stainless steel surface becomes discolored, scrub by rubbing only in the direction of the finish grain. Do not use steel wool.
- b. **Cleaning Interior Surfaces:**  
The inside of the cabinet is coated with a baked-on finish. To clean, use mild soapy water and cloth or sponge.
- c. **Condenser:**  
For efficient operation, it is recommended that the condenser coil and fans be cleaned every 3 to 6 months. Remove front grille for access. Vacuum clean front surface of coil thoroughly or direct forced air through condenser fins. Failure to clean condenser can cause compressor malfunction and will VOID WARRANTY!
- d. **Condensate Pan:**  
Condensate pan should be cleaned periodically to prevent odors and maintain evaporation efficiency.
- e. **Evaporator Housing:**  
If internal parts are to be serviced, lower housing to gain access. Some Models require removing drain tube first. Most Models have a separate access cover for the thermostat and switches.
- f. **Fluorescent Lamps:**  
If your unit is equipped with fluorescent lights, replace with the same size and wattage lamp. DO NOT use reduced wattage lamps. The reduced wattage lamps generally fail to light below 60°F. (16°C) and WILL damage the ballast.

#### 4. **SERVICING:**

All Beverage-Air products are inspected and performance tested at the factory before crating to insure years of satisfactory operation. However, in time, minor servicing will be necessary to maintain or restore peak performance of the cabinet in particular applications. Problems usually encountered and the corrections are as follows:

**Problem:** High temperature of product or cabinet interior.

**Correction:** (1) Inside rear wall might be blocked with product. Be sure space between shelves, in center of cabinet, is open for proper air circulation, (2) Very high usage, or door left open, will raise temperature. Give cabinet time to pull back down. (3) Cabinet might be in defrost cycle, check timer box for position of cam. (4) Condenser could be clogged with dirt, cutting down air flow. Check and clean, if dirty.

A drier is installed in the system. Its purpose is to trap minute particles of foreign material and absorb any moisture in the system.

Liquid refrigerant control to the evaporator of the system is accomplished by the use of either an expansion valve or a capillary tube. This capillary tube is soldered to the suction line to form a heat exchanger which subcools the liquid refrigerant to maintain high efficiency within the system.

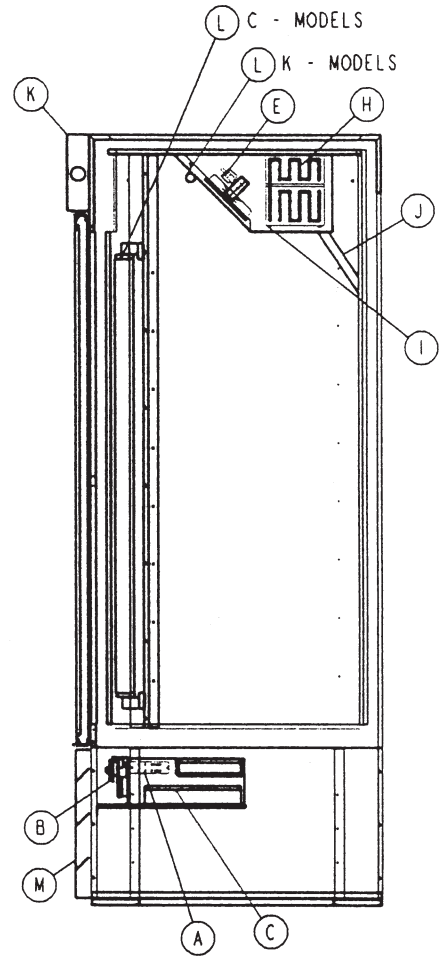
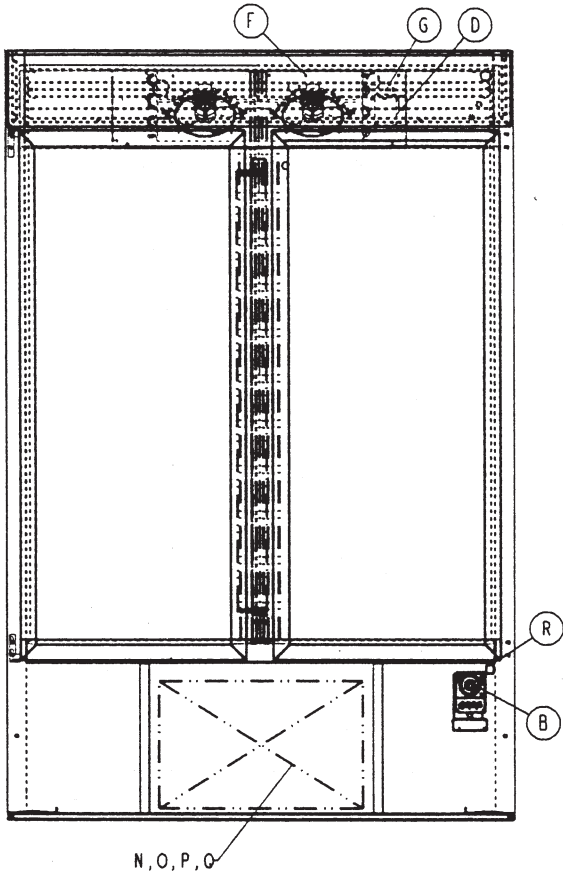

**NOTE: Some components are not used on all models**

- |                                 |                                    |                               |
|---------------------------------|------------------------------------|-------------------------------|
| A. Terminal Block               | G. Limit Switches (Fans & Defrost) | M. Bottom grille              |
| B. Timer                        | H. Evaporator                      | N. Condenser                  |
| C. Ballast                      | I. Defrost heater                  | O. Condenser Motor            |
| D. Temp. Control                | J. Drain                           | P. Condensate Pan             |
| E. Evap. Motors                 | K. Top Grille or Sign Panel        | Q. Compressor                 |
| F. Expansion Valve on cap. Tube | L. Interior Lamp                   | R. Kill Switch & Junction Box |

# HINGE TO DOOR AND DOOR TO CABINET

## ASSEMBLY INSTRUCTIONS

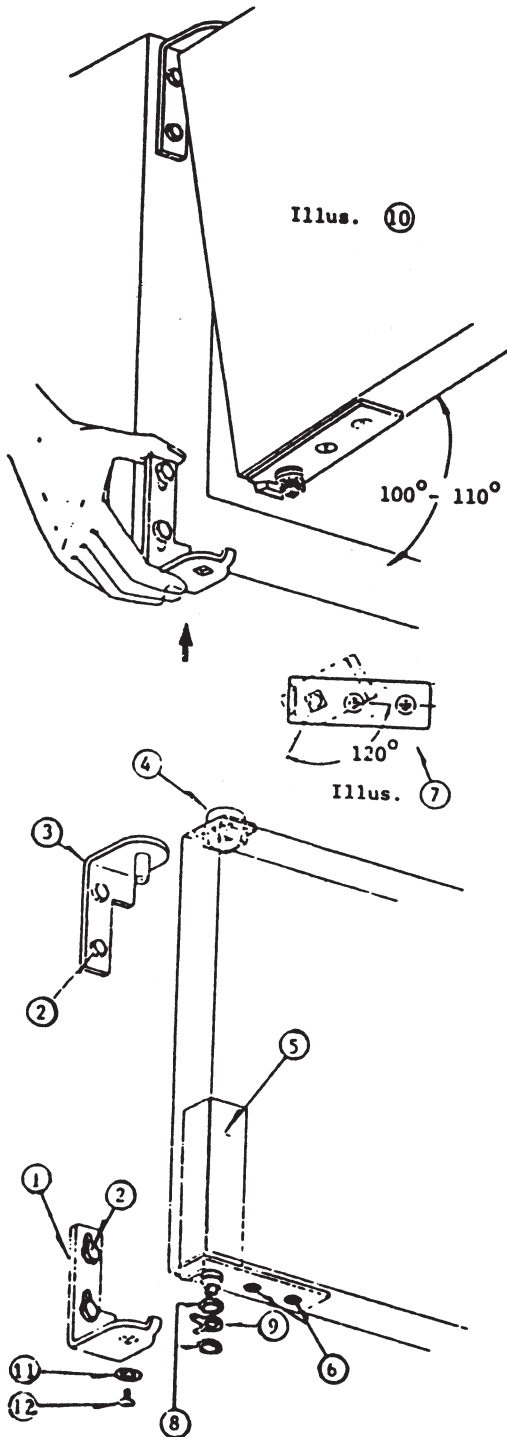

A. Place lower bracket (1) in position on cabinet and loosely fasten with 1/4" hex head bolts, (2). Brackets must be allowed to move up with hand pressure.

B. Place upper bracket (3) in position on cabinet and tightly fasten with 1/4" hex head bolts, (2).

C. Push nylon pivot bushing (4) into the square opening at the door top.

D. Insert cartridge assembly (5) into square opening on bottom of door and secure with #10 countersunk screws, (6).

E. Using the square opening of an extra bottom bracket or a wrench, rotate the square head of the cartridge shaft approximately 120° in closing direction of door. Hinge is now preloaded and ready to be secured to door bracket (See Illus. 7.)

F. Place nylon washer (8), stop spring (9) and second washer (8) over cartridge shaft. Tape to door to secure during mounting of door. Spring, (9) should have tabs facing front of door.

G. Hold door in a 100° position from cabinet face as shown in Illus. (10). Proceed to place upper corner over the protruding bracket pin. Insert square shaft of cartridge into square opening of bottom bracket.

H. Proceed to insert bottom retaining screw, (11). Fasten securely . . . Door can now be closed and will function properly.

# SERVICE AND ANALYSIS CHART

# REFRIGERATION SYSTEM

MALFUNCTION	POSSIBLE CAUSE	SOLUTION
Compressor will not start no hum	<ol style="list-style-type: none"> <li>1. Line cord not plugged in</li> <li>2. Fuse removed or blown.</li> <li>3. Overload protector tripped.</li> <li>4. Control stuck in open position.</li> <li>5. Wiring improper or loose.</li> </ol>	<ol style="list-style-type: none"> <li>1. Plug in line cord.</li> <li>2. Replace fuse.</li> <li>3. Refer to electric section.</li> <li>4. Repair or replace control.</li> <li>5. Check wiring against diagram.</li> </ol>
Compressor will not start hums but trips on overload protector.	<ol style="list-style-type: none"> <li>1. Improperly wired.</li> <li>2. Low voltage to unit.</li> <li>3. Start capacitor defective.</li> <li>4. Relay failing to close.</li> </ol>	<ol style="list-style-type: none"> <li>1. Check wiring against diagram.</li> <li>2. Determine reason and correct.</li> <li>3. Determine reason and replace.</li> <li>*4. Determine reason and correct. Replace if necessary.</li> </ol>
Compressor starts, but does not switch off of starting winding.	<ol style="list-style-type: none"> <li>1. Low voltage to unit.</li> <li>2. Relay failing to open.</li> <li>3. Run capacitor defective.</li> <li>4. Compressor motor has a winding open or shorted.</li> </ol>	<ol style="list-style-type: none"> <li>1. Determine reason and correct.</li> <li>2. Determine reason and correct, replace if necessary.</li> <li>3. Determine reason and replace.</li> <li>4. Replace compressor.</li> </ol>
Compressor starts and runs, but short cycles on overload protector.	<ol style="list-style-type: none"> <li>1. Additional current passing through overload protector.</li> <li>2. Low voltage to unit.</li> <li>3. Overload protector defective.</li> <li>4. Run capacitor defective.</li> <li>5. Excessive discharge pressure.</li> <li>6. Compressor too hot - return gas hot.</li> </ol>	<ol style="list-style-type: none"> <li>1. Check wiring diagram. Check for added fan motors, pump, etc. connected to wrong side of protector.</li> <li>2. Determine reason and correct.</li> <li>3. Check current, replace protector.</li> <li>4. Determine reason and replace.</li> <li>5. Check ventilation, restrictions in cooling medium, restrictions in refrigeration system.</li> <li>*6. Check refrigerant charge (fix leak) add if necessary.</li> </ol>
Units runs OK, but short cycles.	<ol style="list-style-type: none"> <li>1. Overload protector.</li> <li>2. Cold control.</li> <li>3. Overcharge.</li> <li>4. Air in system.</li> <li>5. Undercharge.</li> </ol>	<ol style="list-style-type: none"> <li>1. Check wiring diagram.</li> <li>2. Differential set too close - widen.</li> <li>3. Reduce refrigerant charge.</li> <li>*4. Recover and recharge.</li> <li>*5. Fix leak, and refrigerant.</li> </ol>
Unit operates long or continuously.	<ol style="list-style-type: none"> <li>1. Shortage of refrigerant.</li> <li>2. Control contracts stuck or frozen closed.</li> <li>3. Evaporator coil iced.</li> <li>4. Restriction in refrigeration system.</li> <li>5. Dirty condenser.</li> </ol>	<ol style="list-style-type: none"> <li>*1. Fix leak, add charge.</li> <li>2. Clean contracts or replace control.</li> <li>3. Defrost.</li> <li>*4. Determine location and remove.</li> <li>5. Clean condenser.</li> </ol>
Start capacitor open, shorted or blown.	<ol style="list-style-type: none"> <li>1. Relay contacts not opening properly.</li> <li>2. Low voltage to unit.</li> <li>3. Improper relay.</li> </ol>	<ol style="list-style-type: none"> <li>1. Clean contracts or replace relay if necessary.</li> <li>2. Determine reason and correct.</li> <li>3. Replace.</li> </ol>
Run capacitor open, shorted or blown.	<ol style="list-style-type: none"> <li>1. Improper capacitor.</li> <li>2. Excessive high line voltage. (110% or rated-max).</li> </ol>	<ol style="list-style-type: none"> <li>1. Determine correct size and replace.</li> <li>2. Determine reason and correct.</li> </ol>
Relay defective or burned out.	<ol style="list-style-type: none"> <li>1. Incorrect relay.</li> <li>2. Line voltage to high or to low.</li> <li>3. Relay being influenced by loose vibrating mounting.</li> </ol>	<ol style="list-style-type: none"> <li>1. Check and replace.</li> <li>2. Determine reason and correct.</li> <li>3. Replace.</li> </ol>
Space temperature too high.	<ol style="list-style-type: none"> <li>1. Control setting too high.</li> <li>2. Improper overcharge.</li> <li>3. Inadequate air circulation.</li> </ol>	<ol style="list-style-type: none"> <li>1. Reset control.</li> <li>*2. Recover refrigerant and recharge with proper charge specified on the data plate.</li> <li>3. Improve air movement.</li> </ol>
Cooler freezing beverage.	<ol style="list-style-type: none"> <li>1. Control settings.</li> </ol>	<ol style="list-style-type: none"> <li>1. Adjust control.</li> </ol>
Unit noise.	<ol style="list-style-type: none"> <li>1. Loose parts or mountings.</li> <li>2. Tubing rattle.</li> <li>3. Bent fan blade causing vibration.</li> <li>4. Fan motor bearings worn.</li> </ol>	<ol style="list-style-type: none"> <li>1. Find and tighten.</li> <li>2. Reform to be free of contact.</li> <li>3. Replace blade.</li> <li>4. Replace motor.</li> </ol>

**\*ALL SERVICING MUST COMPLY WITH STATE AND FEDERAL REQUIREMENTS.  
FEDERAL LAW REQUIRES THAT SOME REFRIGERANTS BE RECOVERED PRIOR TO SERVICING.**

## BEVERAGE AIR

POST OFFICE BOX 5932  
SPARTANBURG, SOUTH CAROLINA 29304  
PHONE: 864-582-8111 FAX: 864-582-5083

# REFRIGERATION SYSTEM

# SERVICE AND ANALYSIS CHART

## REFRIGERATION SYSTEM

The refrigeration system consists of a hermetically sealed compressor, finned evaporator and condenser. All models are forced air, with liftout refrigeration system.

## CONDENSER

The condenser has wide finned spaces which allow more air passage with less dirt or dust accumulation. The condenser still requires periodic cleaning (3-6 months) for maximum efficiency.

## CONDENSER FAN MOTOR

The condenser fan motor assembly is mounted between the condenser and compressor. Air is drawn through the condenser, over and under the body of the compressor and then out of the rear of the unit compartment. The motor is wired to cycle with the compressor but will continue to operate should the compressor cut out on the overload. (The motor is permanently lubricated; therefore, oiling is not required.)

## DRIER

The drier is installed in the system just before the capillary tube. Its purpose is to trap minute particles of foreign material and absorb any moisture in the system.

## REFRIGERATION SERVICE

### EVACUATION

Moisture in the refrigeration system is directly or indirectly the cause of more problems and complaints than all other factors combined.

When large amounts are present, system freeze ups will occur. Even in minute amounts, moisture will combine with refrigerants to form acids. The corrosive action of this acid forms sludge which will plug the lines and drier.

Only a vacuum pump should be used for evacuation because operating the compressor in a deep vacuum could cause serious damage to the compressor windings.

Since most field type vacuum pumps cannot pull a low enough vacuum to remove moisture from the system, it is recommended that the system be triple evacuated, breaking each time with dry refrigerant. Use care to purge air from the charging hose when breaking the vacuum. After third vacuum, backseat valves and proceed with replacement charge.

### CHARGING REFRIGERATION SYSTEM

Since capillary tube systems have small critical refrigerant charges, we recommend that a field charge either be weighed in or put in from a portable charge board. After maximum vacuum has been obtained as detailed in evacuation, attach charging cylinder to the suction line making sure to purge air from hose with refrigerant. Put small amount of charge in system before applying power to unit. With the unit running, allow refrigerant to run slowly into the system until the desired charge is reached.

#### OVERCHARGE

When the cabinet has pulled down to operating temperature, an indication of an overcharge is that the suction line will be cooler than normal with the compressor running. Running time will be higher than normal. Suction line will sweat or frost.

Recover excessive refrigerant from the system very carefully in small amounts waiting several minutes for the system to balance.

#### UNDERCHARGE

An undercharge or shortage of refrigerant will result in any or all of the following:

1. Lower than normal head pressure.
2. Lower than normal suction pressure.
3. Excessive or continuous operation of compressor.
4. Higher than normal cabinet temperature.

When correct charge has been obtained with cabinet at operating temperature, several seconds after compressor has started after cycle, suction line will frost and remain for approximately (60) seconds.

**\*ALL SERVICING MUST COMPLY WITH STATE AND FEDERAL REQUIREMENTS.  
FEDERAL LAW REQUIRES THAT SOME REFRIGERANTS BE RECOVERED PRIOR TO SERVICING.**

# METHODS FOR CLEANING STAINLESS STEEL

MALFUNCTION	CLEANING AGENT*	METHOD OF APPLICATION**	EFFECT ON FINISH
Routine Cleaning	Soap or ammonia, or detergent and water	Sponge with cloth, then rinse with clear water and wipe dry.	Satisfactory for use on all finishes.
Smears and Fingerprints.	Arcal 20, Lac-O-Nu, Lumin Wash O'Cedar Cream Polish, Stainless Steel.	Rub with cloth as directed on the package.	Satisfactory for use on all finishes. Provides barrier film to minimize prints.
Stubborn spots and stains, baked-on splatter, and other discolorations.	Allchem Concentrated Cleaner.	Apply with damp sponge or cloth.	Satisfactory for use on all finishes.
	Samae, Twinkle or Cameo Copper Cleaner.	Rub with damp cloth.	Satisfactory for use on all finishes if rubbing is light.
	Grade FFF Italian pumice, whiting, or talc.	Rub with damp cloth.	Use in direction of polish lines on No. 4 (polished) finish. Use light pressure on No.2 (mill) and nos. 7 and 8 (polished) finishes.
	Liquid NuSteal.	Rub with damp cloth. Use small amount of cleaner.	Use in direction of polish lines on No. 4 (polished) finish. May scratch No. 2 (mill) and nos. 7 and 8 (polished) finishes.
	Paste NuSteal or DuBois Temp.	Rub with damp cloth. Use small amount of cleaner.	Use in direction of polish lines on No. 4 (polished) finish. May scratch No. 2 (mill) and nos. 7 and 8 (polished) finishes.
	Coppers stainless Steel Cleaner, Revere Stainless Cleaner.	Apply with damp sponge or cloth.	Use in direction of polish lines on No. 4 (polished) finish. May scratch No. 2 (mill) and nos. 7 and 8 (polished) finishes.
	Household cleaners, such as Old Dutch, Lighthouse, Sun-brite, Wyandotte, Bab-o, Gold Dust, Sapolio, Bon Ami, Ajax, or Comet.	Rub with damp cloth. May contain chlorine bleaches. Rinse thoroughly after use.	Use in direction of polish lines on No. 4 (polished) finish. May scratch No. 2 (mill) and nos. 7 and 8 (polished) finishes.
	Grade F Italian pumice, Steel Bright, Lumin Cleaner, Zud, Restoro, Sta-clean, or Highlite.	Rub with a damp cloth.	Use in direction of polish lines on No. 4 (polished) finish. May scratch No. 2 (mill) and nos. 7 and 8 (polished) finishes.
Heat Tint or Heavy Discoloration	Penny-Brite or Copper-Brite	Rub with a dry cloth using a small amount of cleaner.	Use in direction of polish lines on No. 4 (polished) finish. May scratch No. 2 (mill) and nos. 7 and 8 (polished) finishes.
	Paste NuSteal or Dubose Temp. or Tarnite.	Rub with a dry cloth or stainless steel wool.	Use in direction of polish lines on No. 4 (polished) finish. May scratch No. 2 (mill) and nos. 7 and 8 (polished) finishes.
	Revere Stainless Steel Cleaner.	Apply with damp sponge or cloth.	Use in direction of polish lines on No. 4 (polished) finish. May scratch No. 2 (mill) and nos. 7 and 8 (polished) finishes.
	Allen Polish, Steel Bright, Wyandotte, Bab-o, or Zud.	Rub with a damp cloth.	Use in direction of polish lines on No. 4 (polished) finish. May scratch No. 2 (mill) and nos. 7 and 8 (polished) finishes.
Burnt-on Foods and Grease Fatty Acids, Milkstone (where swabbing or rubbing is not practical).	Easy-Off, De-Grease-It, 4 to 6% hot solution of such agents as trisodium phosphate or sodium tripolyphosphate or 5 to 15% caustic soda solution.	Apply generous coating. Allow to stand for 10-15 minutes. Rinse. Repeated application may be necessary.	Excellent removal, satisfactory for use on all finishes.
Tenacious Deposits, Rusty Discolorations, Industrial Atmospheric Stains.	Oakite no. 33, Dilac Texo 12, Texo n.y., Flash-Klenz, Caddy Cleaner, Turco Scale 4368 or Permag 57.	Swab and soak with clean cloth. Let stand 15 minutes or more according to directions on package. Then rinse and dry.	Satisfactory for use on all finishes.
Hard Water Spots and Scale.	Vinegar.	Swab or wipe with cloth. Rinse with water and dry.	Satisfactory for all finishes.
	5% oxalic acid, 5% sulfuric acid, 5 to 10% phosphoric acid, or Dilac, Oakite no. 33, Texo 12, Texo N.Y.	Swab or soak with cloth. Let stand 10 or 15 minutes. Always follow with neutralizer rinse, and dry.	Satisfactory for all finishes. Effective on tenacious deposits or where scale has built up.

## NOTES:

\*Use of proprietary names is intended only to indicate a type of cleaner, and does not constitute an indorsement. Nor is omission of any cleanser to imply it's inadequacy. It should be emphasized that all products should be used in strict accordance with instructions on package.

\*\*In all applications a stainless steel wool or sponge or fibrous brush or pads are recommended. Avoid use of ordinary steel wool or steel brushes for scouring stainless steel.

## SUGGESTIONS:

\*Use the mildest cleaning procedure that will do the job effectively.

\*Rub in the direction of polish lines for maximum effectiveness and to avoid marring the surface.

\*Rinsing thoroughly with fresh water after cleaning operation.

\*Wipe dry and avoid water marks.

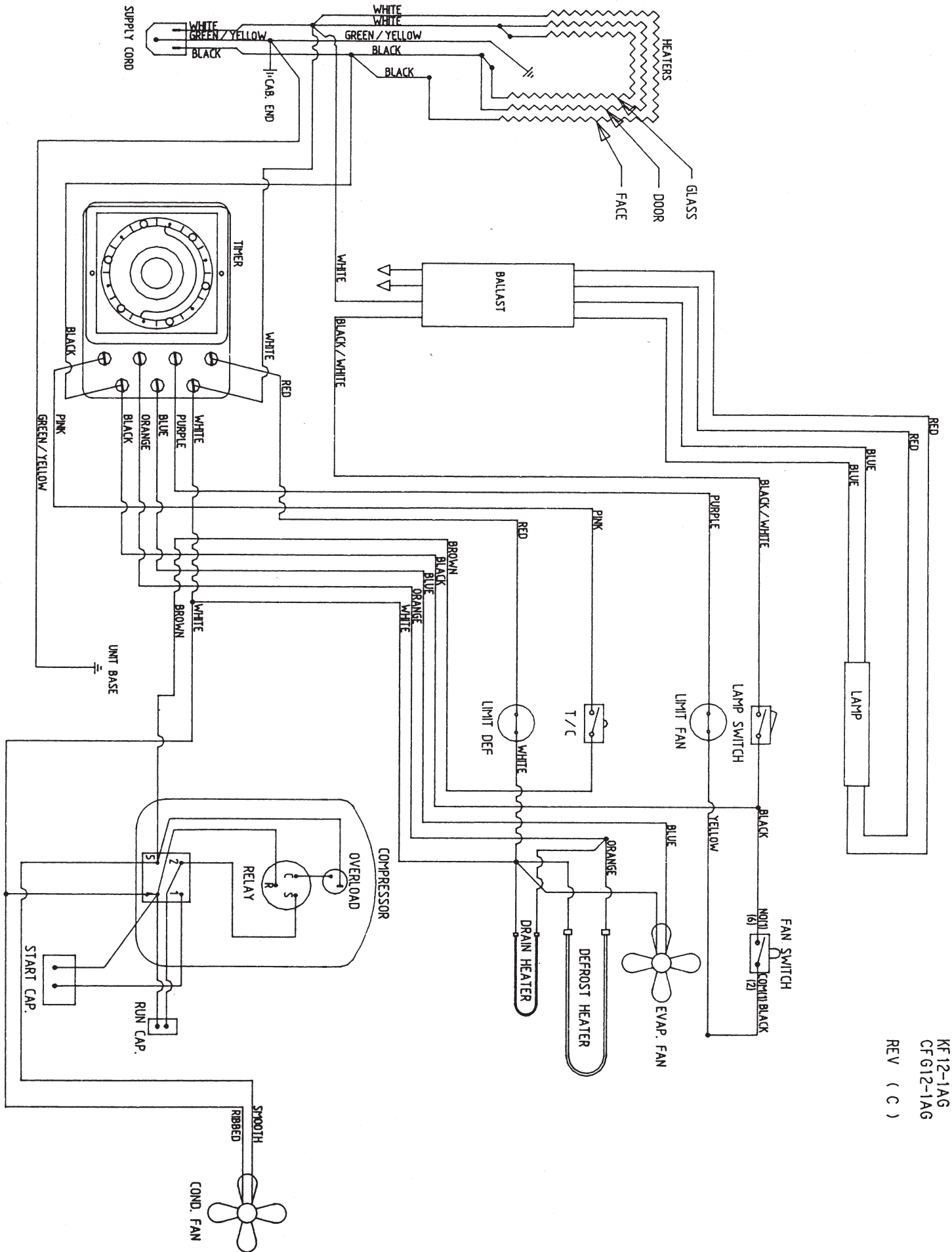

KF 12-1AG  
 CF 612-1AG  
 REV ( C )



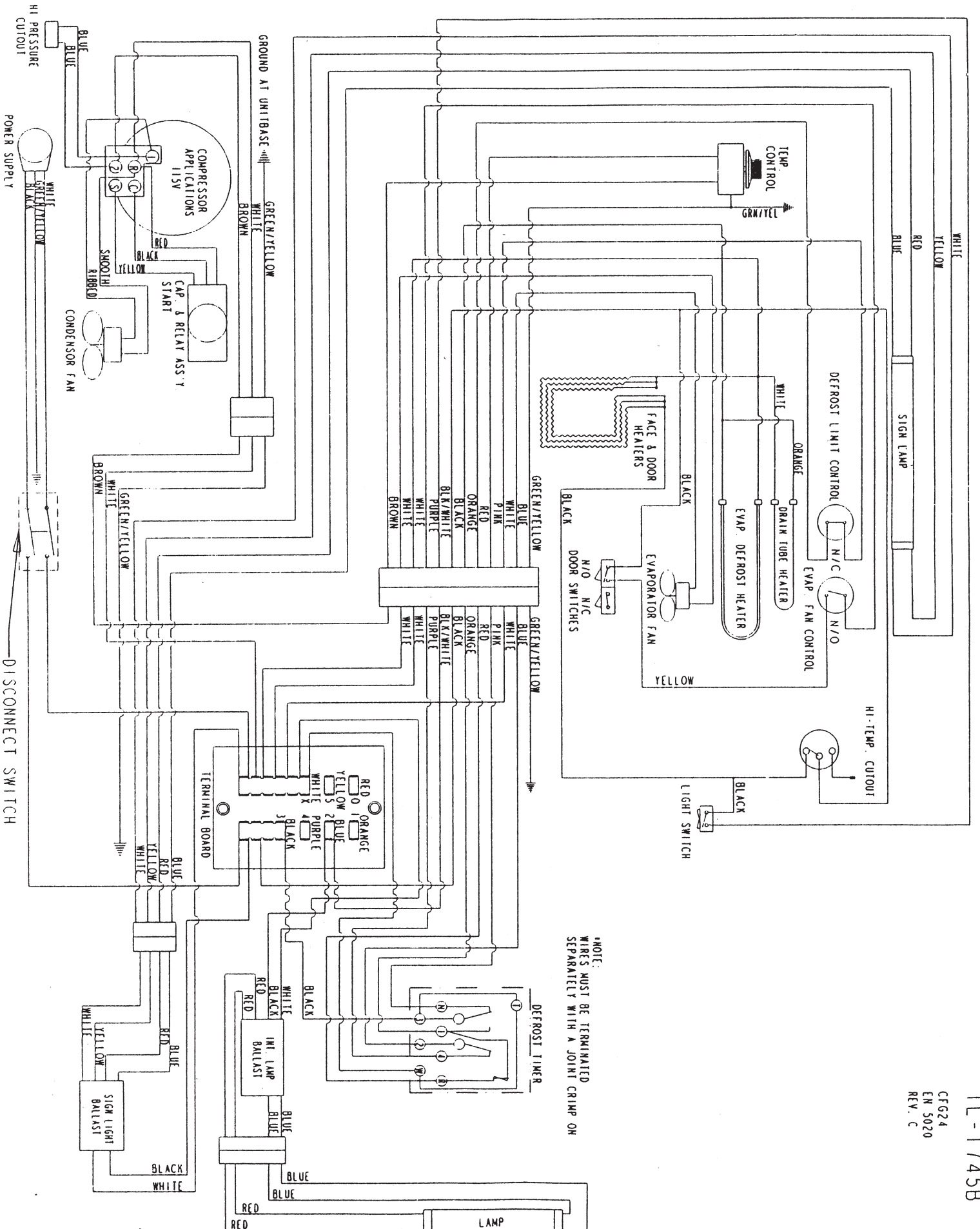

NOTE:  
WIRES MUST BE TERMINATED  
SEPARATELY WITH A JOINT CRIMP ON

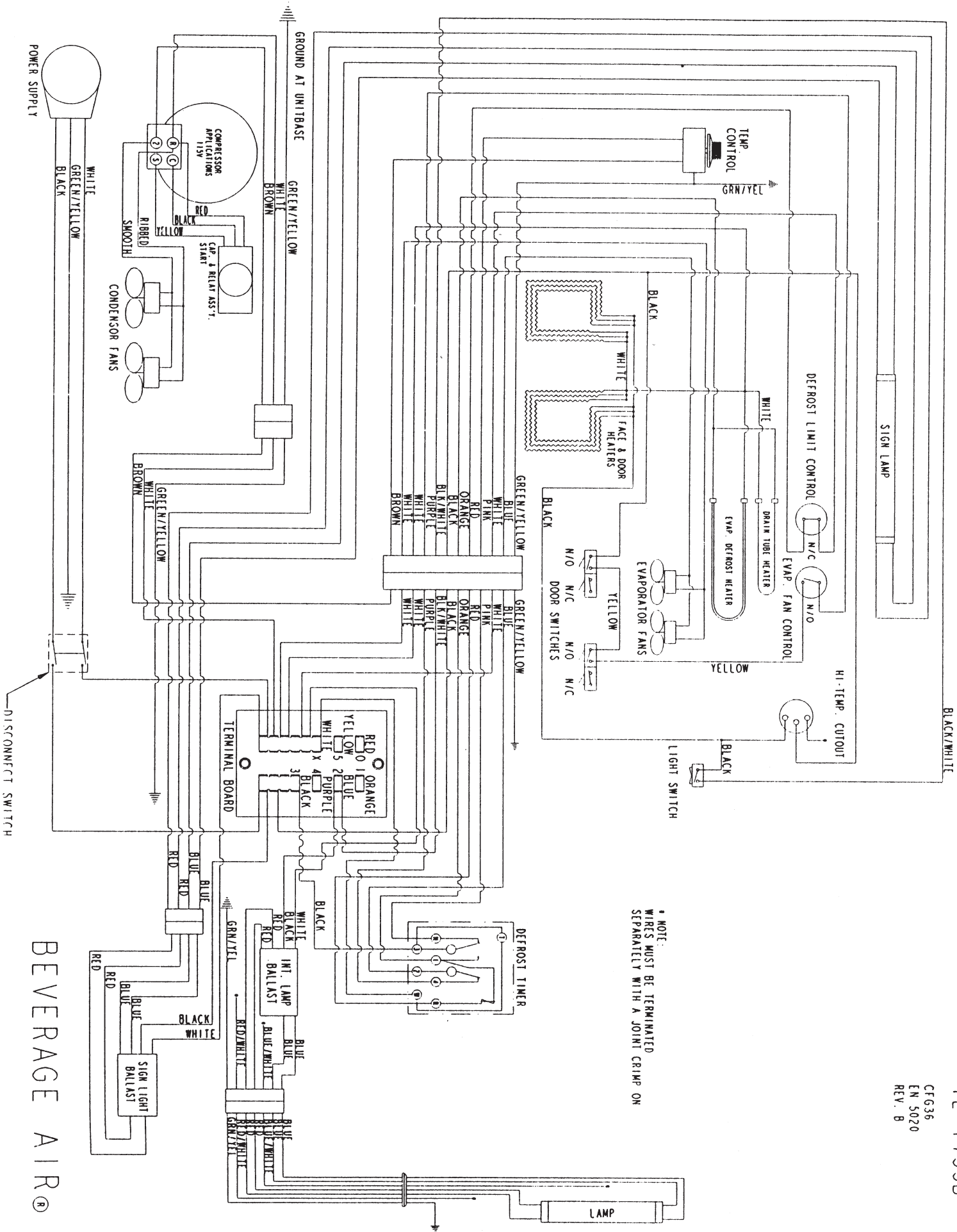

NOTE:  
WIRES MUST BE TERMINATED  
SEPARATELY WITH A JOINT CRIMP ON

BEVERAGE AIR®

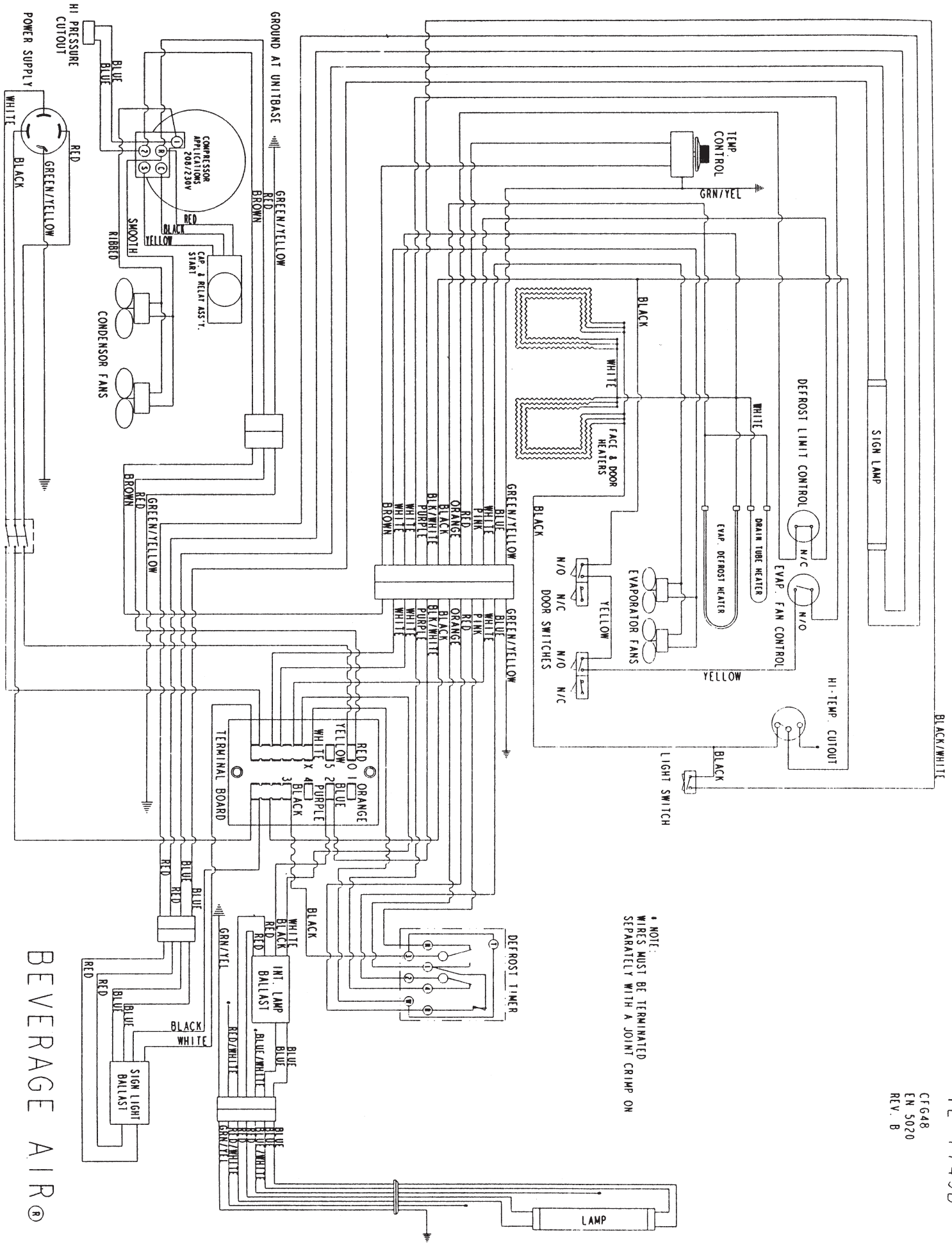

\* NOTE:  
WIRES MUST BE TERMINATED  
SEPARATELY WITH A JOINT CRIMP ON

BEVERAGE AIR®



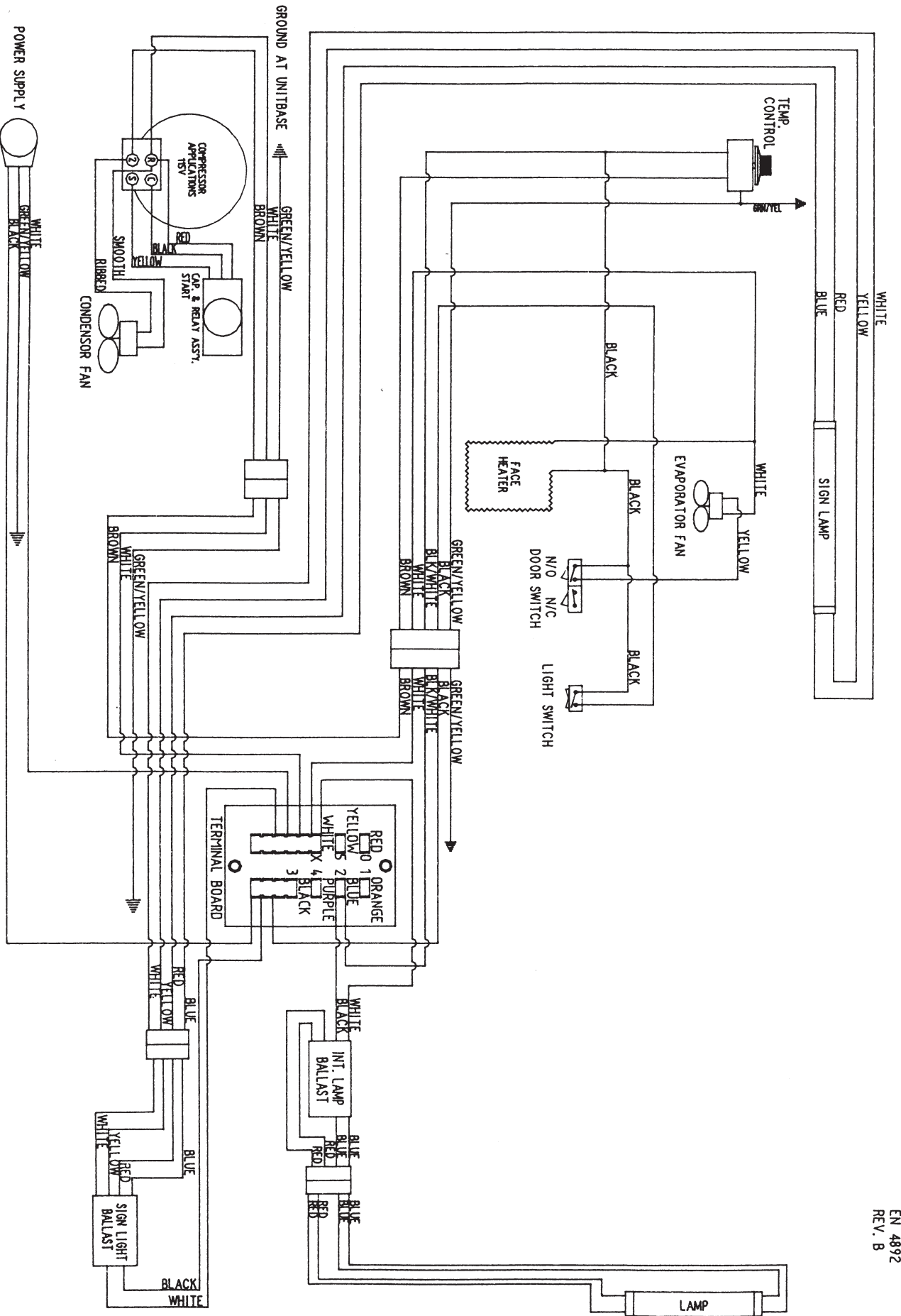

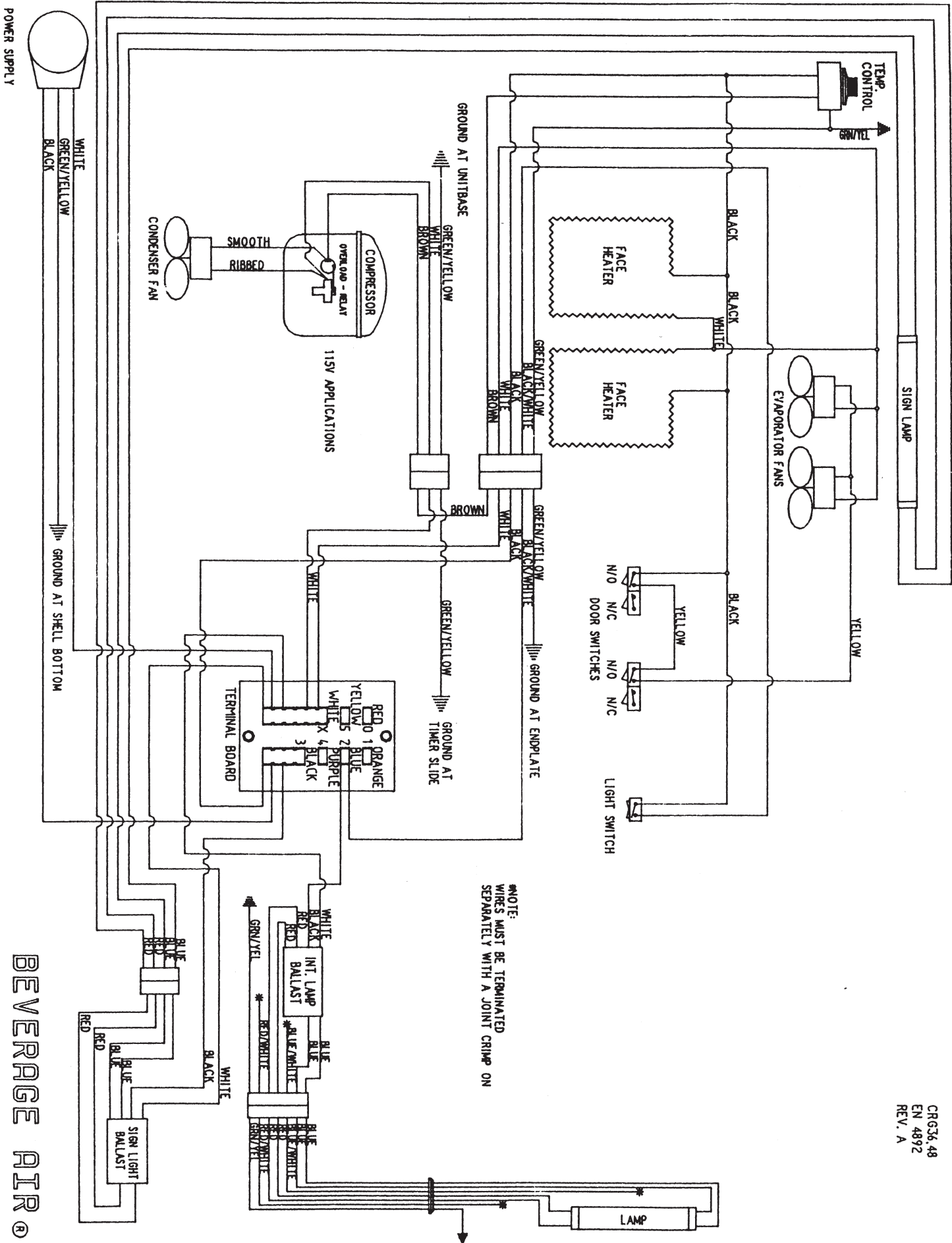

BEVERAGE AIR®

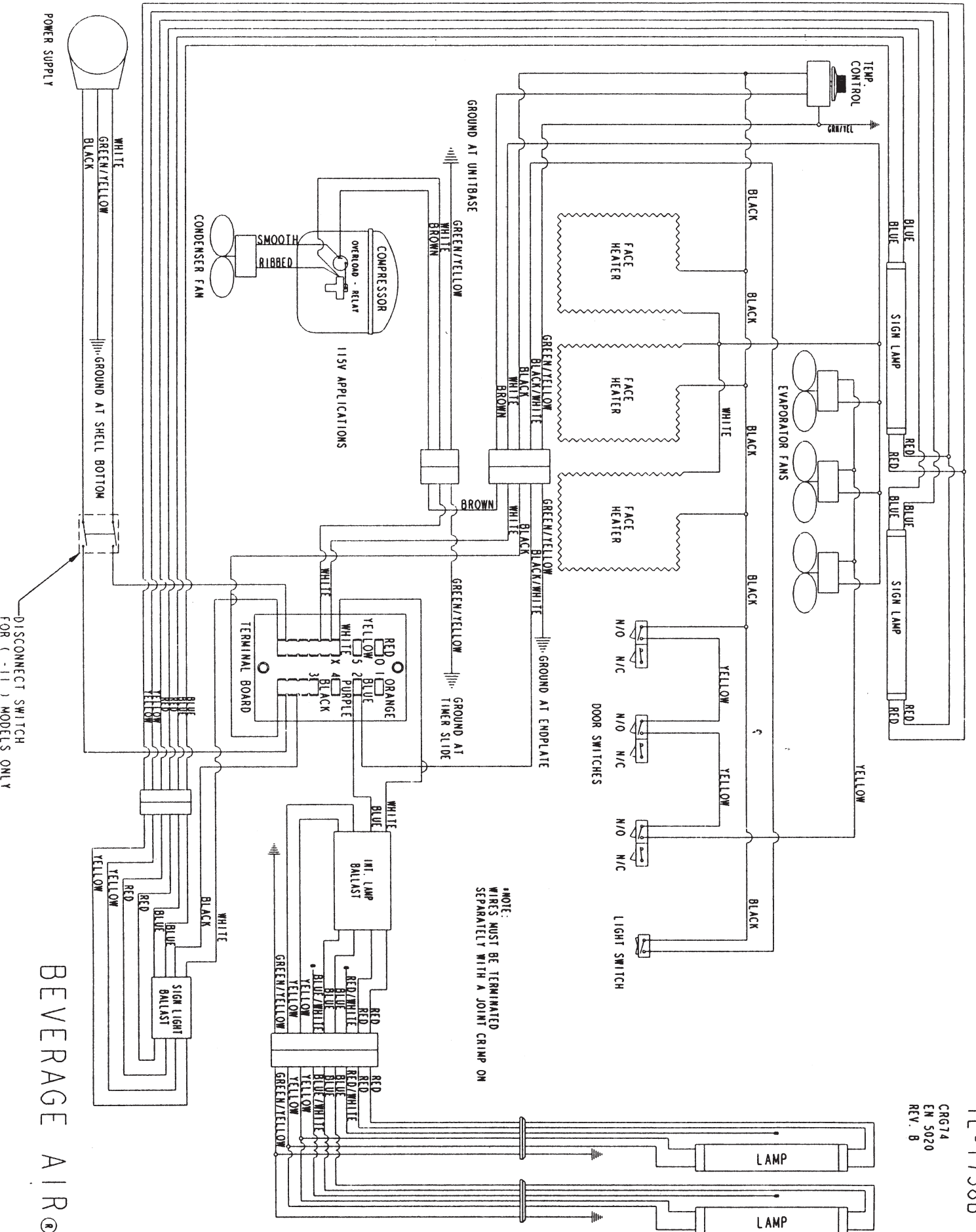

NOTE:  
WIRES MUST BE TERMINATED  
SEPARATELY WITH A JOINT CRIMP ON

BEVERAGE AIR®

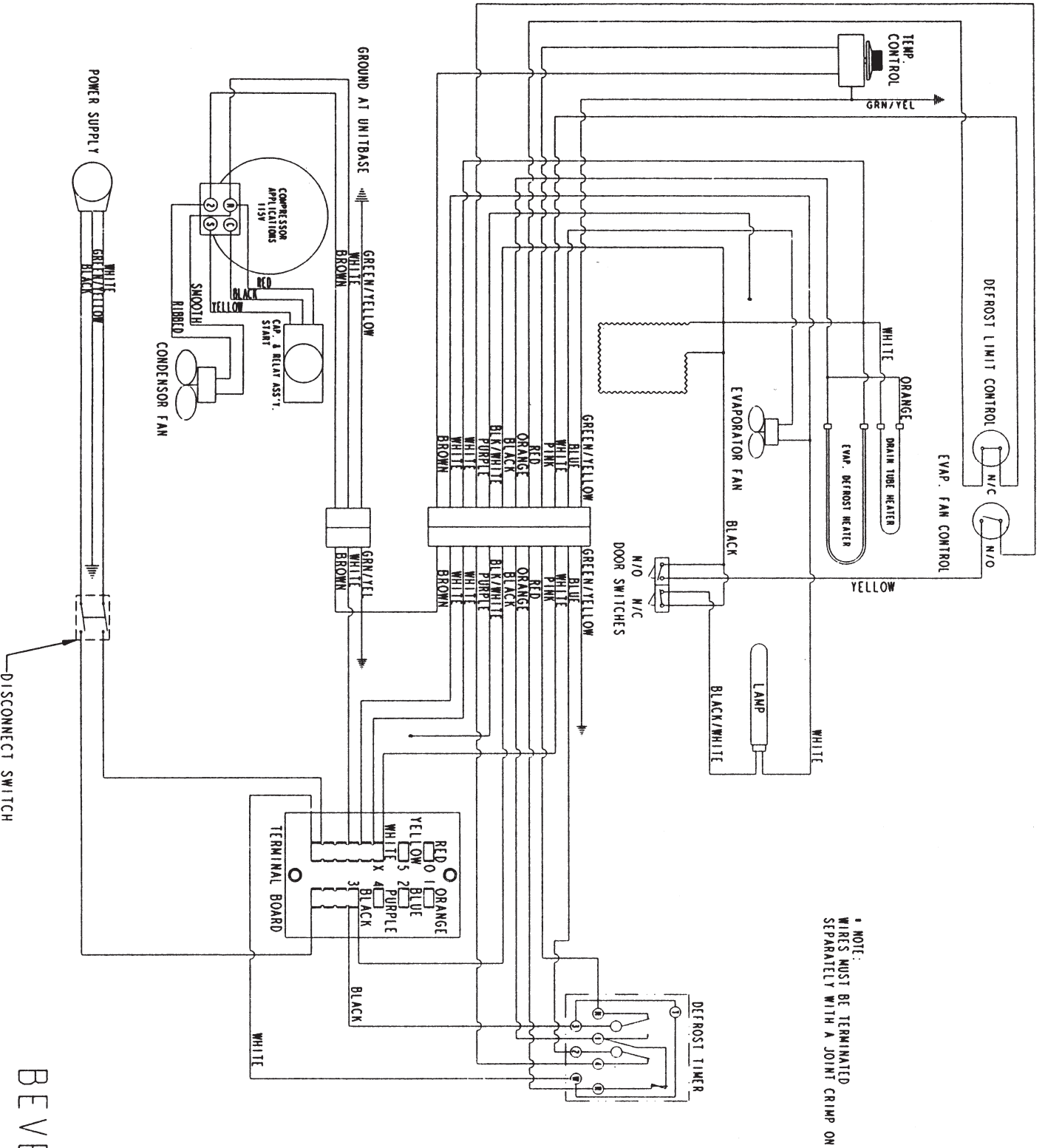

BEVERAGE AIR®



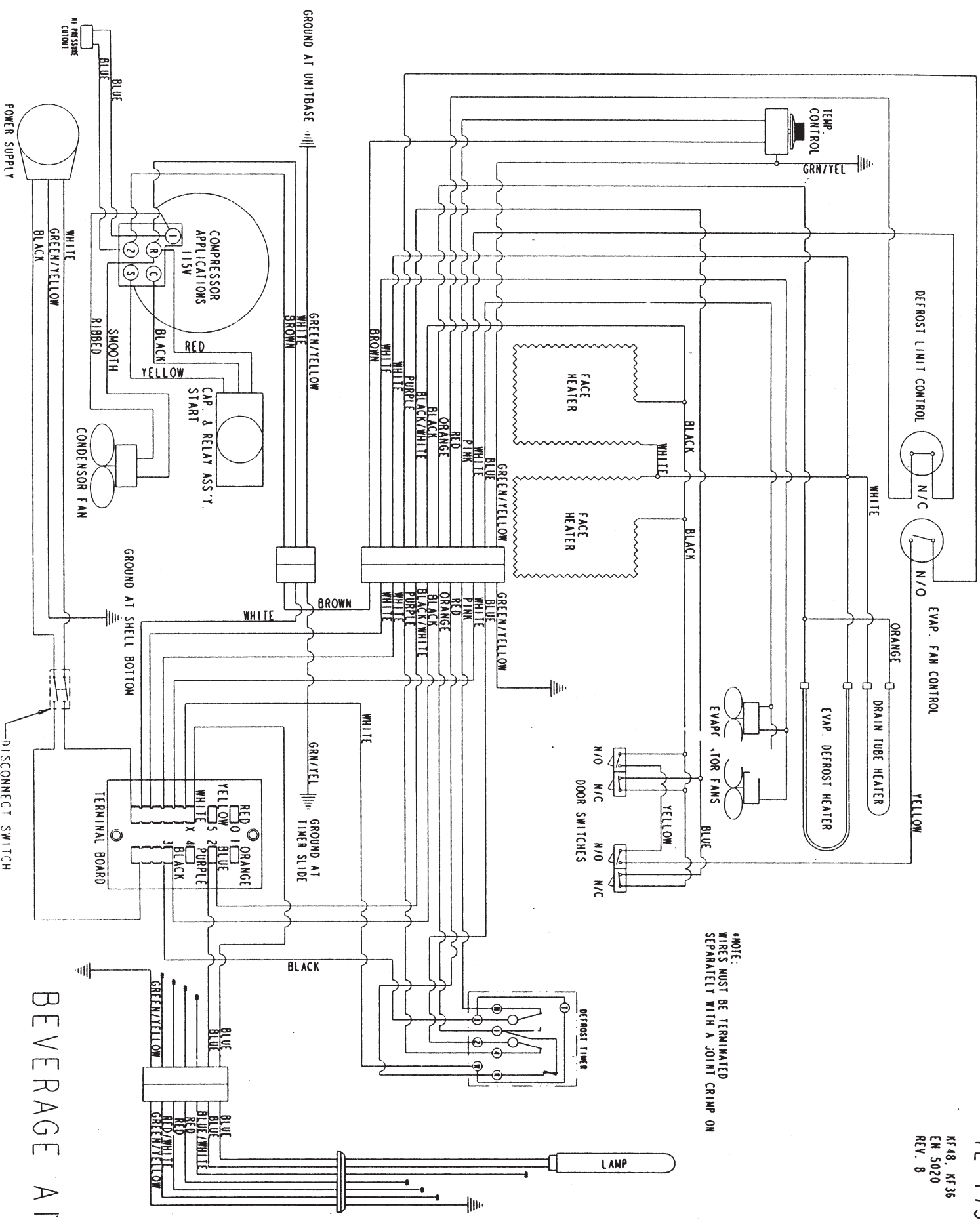

\*NOTE:  
WIRES MUST BE TERMINATED  
SEPARATELY WITH A JOINT CRIMP ON

BEVERAGE AIR®

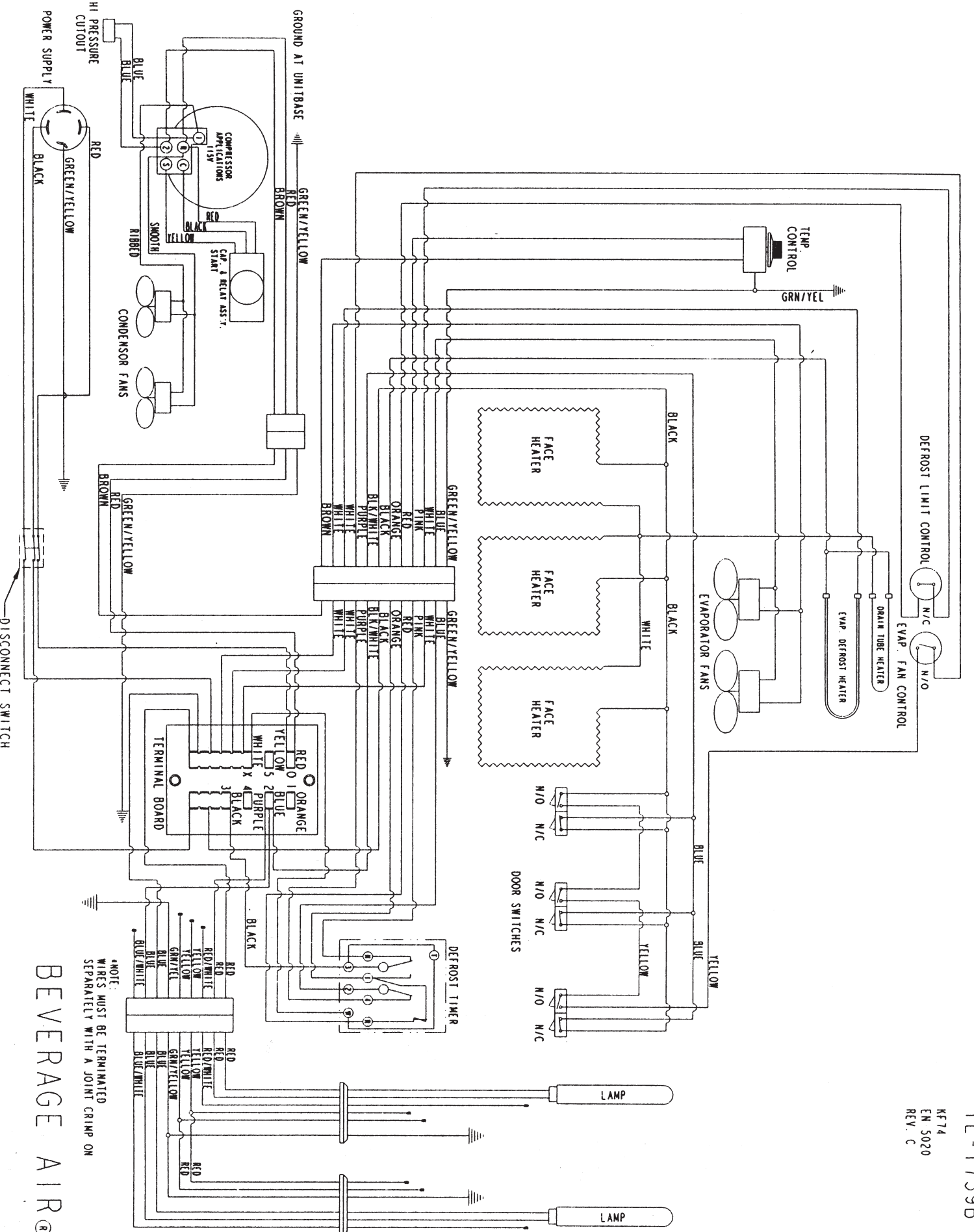

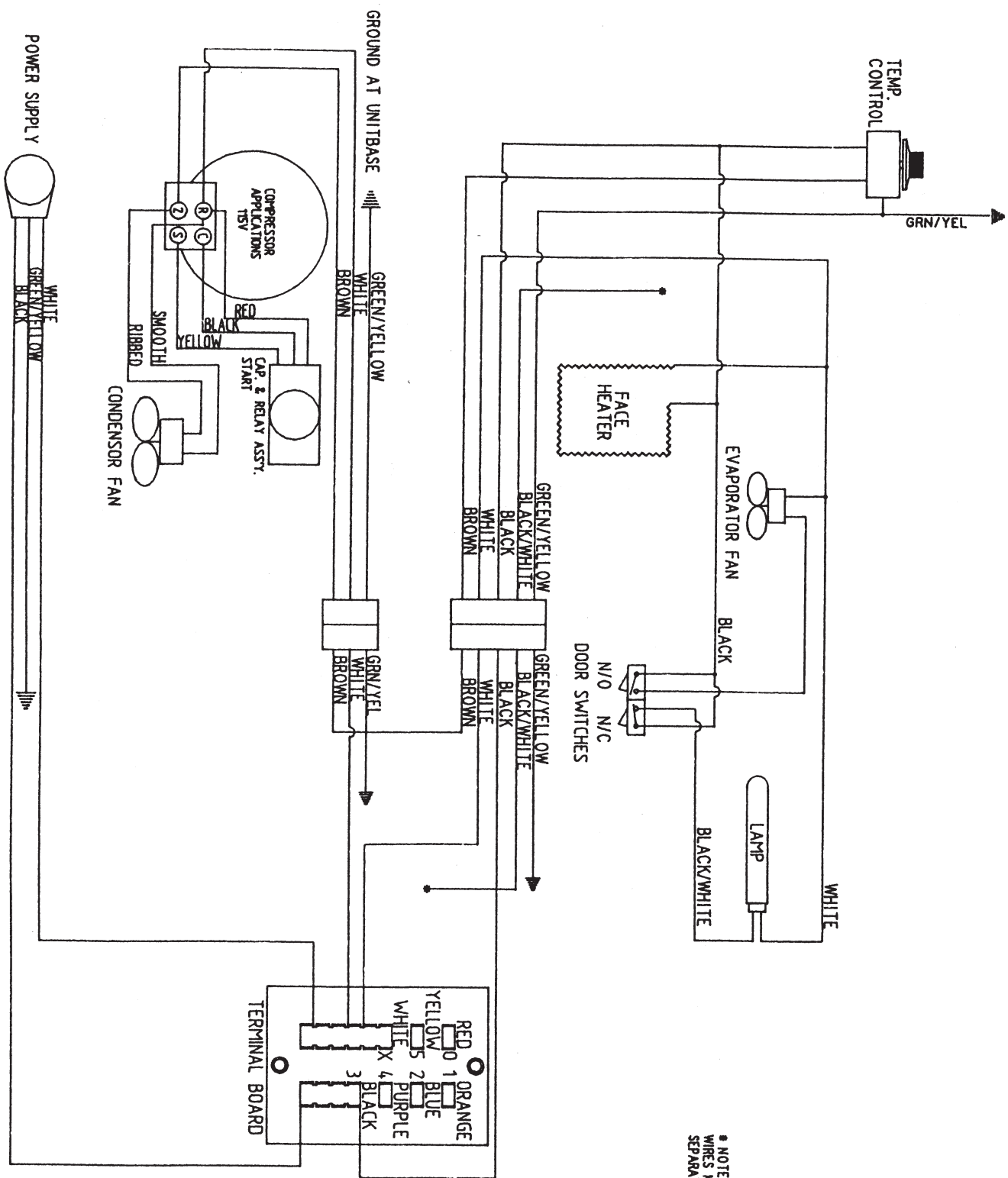

NOTE:  
WIRES MUST BE TERMINATED  
SEPARATELY WITH A JOINT CRIMP ON

BEVERAGE AIR®

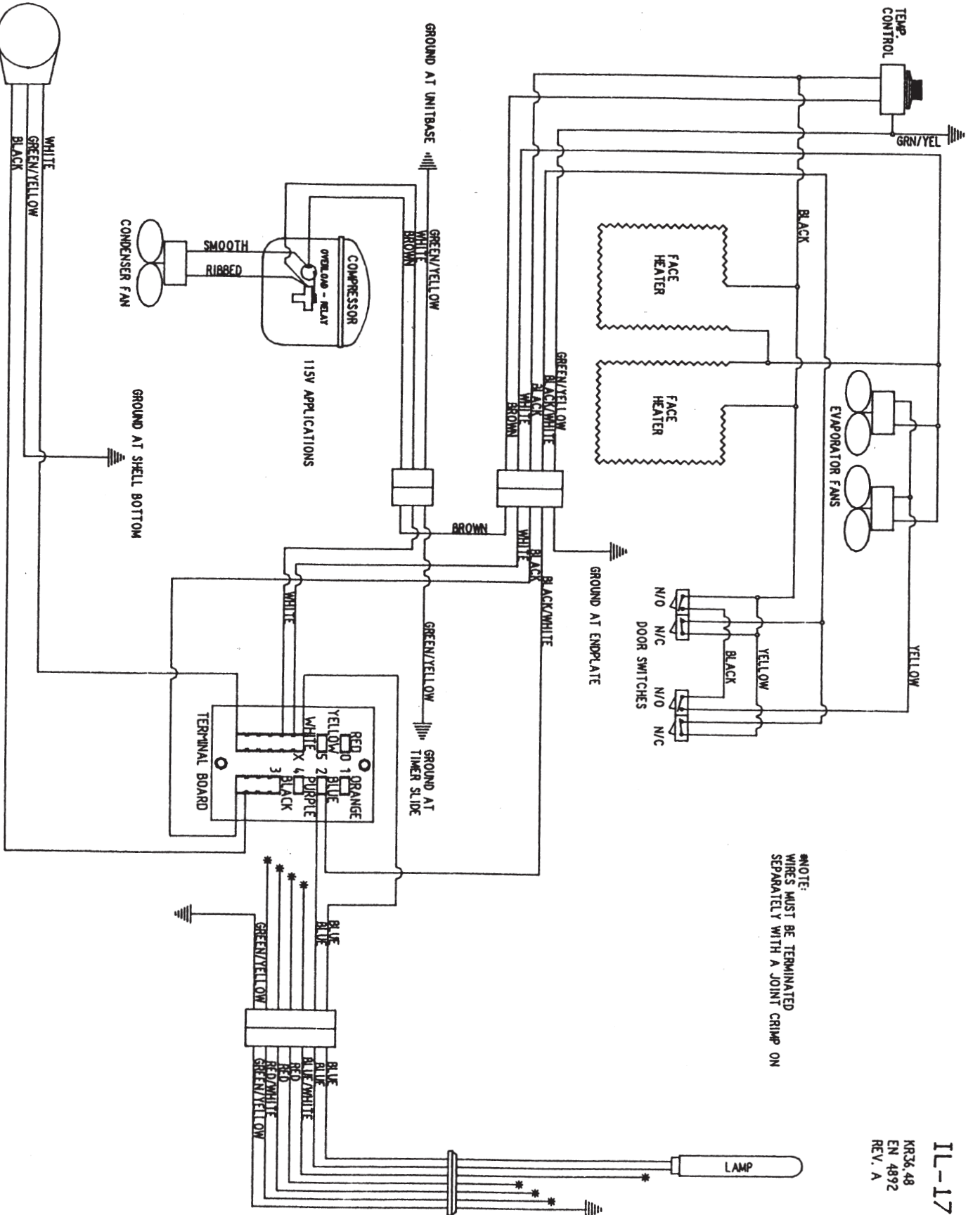

NOTE:  
WIRES MUST BE TERMINATED  
SEPARATELY WITH A JOINT CRIMP ON

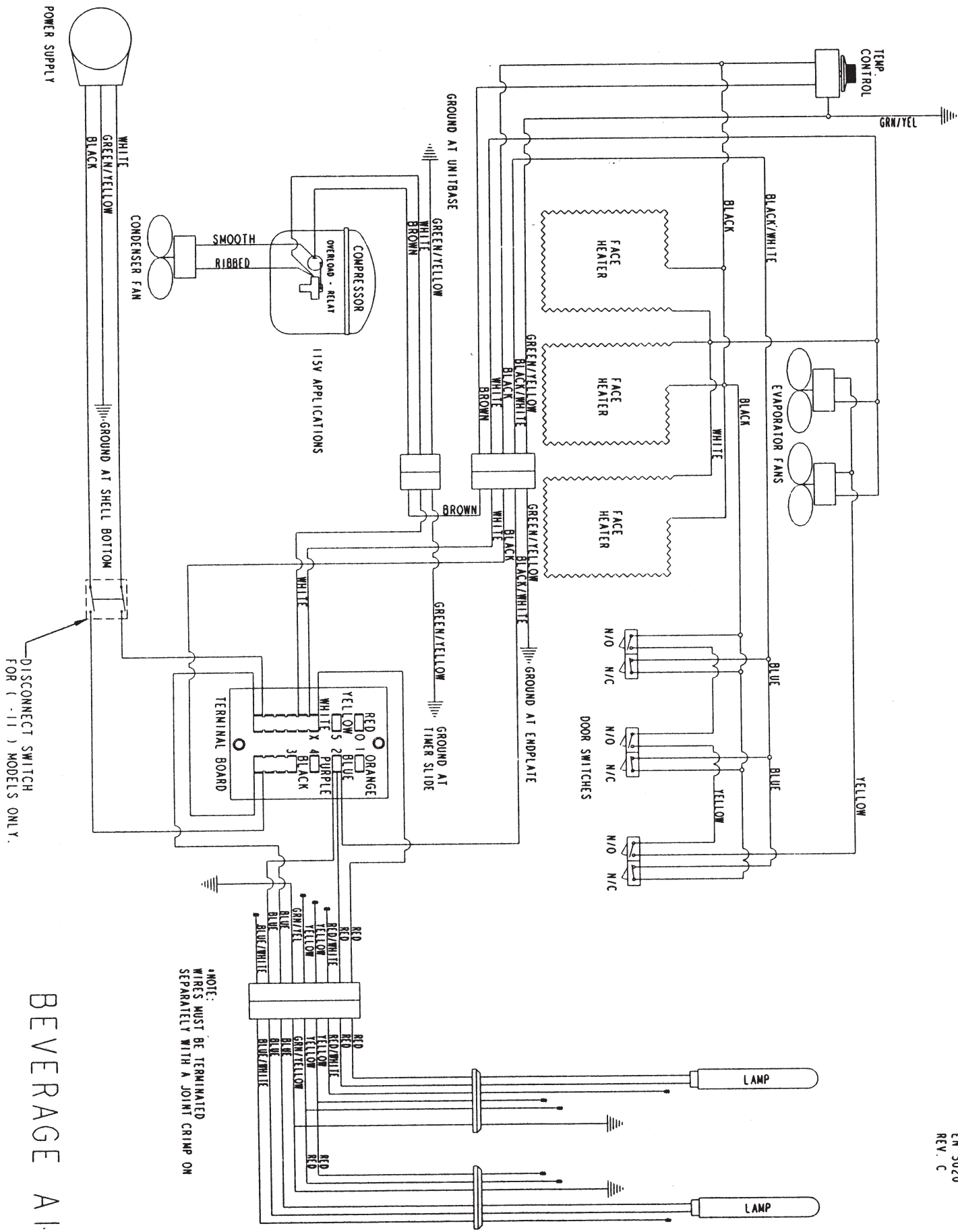

NOTE:  
WIRES MUST BE TERMINATED  
SEPARATELY WITH A JOINT CRIMP ON

BEVERAGE AIR®









## Free Manuals Download Website

<http://myh66.com>

<http://usermanuals.us>

<http://www.somanuals.com>

<http://www.4manuals.cc>

<http://www.manual-lib.com>

<http://www.404manual.com>

<http://www.luxmanual.com>

<http://aubethermostatmanual.com>

Golf course search by state

<http://golfingnear.com>

Email search by domain

<http://emailbydomain.com>

Auto manuals search

<http://auto.somanuals.com>

TV manuals search

<http://tv.somanuals.com>